

CONSERVING HOUSING FORM

Growth Potential of a Low Density Residential Neighborhood



by Stephen Albert Casentini
A.B. in Architecture
University of California
Berkeley, California
1979

Submitted in partial fulfillment of the re-
quirements for the degree of Master of Archi-
tecture at the Massachusetts Institute of
Technology
June 1983

© Stephen Albert Casentini 1983

The author hereby grants to M.I.T. permission
to reproduce and to distribute copies of this
thesis document in whole or in part.

Signature of Author _____

Department of Architecture
May 6, 1983

Certified by _____

Chester Sprague
Associate Professor of Architecture

Accepted by _____

Jan Wampler
Associate Professor of Architecture
Chairman Departmental Committee
for Graduate Students

Archives
MASSACHUSETTS INSTITUTE
OF TECHNOLOGY

MAY 26 1983

ABSTRACT

CONSERVING HOUSING FORM: GROWTH POTENTIAL OF A LOW DENSITY RESIDENTIAL NEIGHBORHOOD

by Stephen Albert Casentini

Submitted to the Department of Architecture on May 6, 1983; in partial fulfillment of the requirements for the degree of Master of Architecture.

Abstract

This study explores the potential of a low density residential neighborhood to accommodate increases in its unit density (number of households), while promoting the continued use or reuse of the existing housing stock.

The process of increasing unit density in an existing tissue will be called consolidation.

Several types and scales of consolidation are projected into a "suburban" block located in Newton, MA, for quantitative and qualitative

analysis. The information gathered is then used to help formulate a set of consolidation standards and principles for this particular block type. Several site plans are drawn using the standards as a method for assessing their ability to generate consolidation which is harmonious with the existing housing environment.

Thesis Supervisor: Chester Sprague
Title: Associate Professor of Architecture

CONTENTS

ABSTRACT	3
ACKNOWLEDGEMENTS	7
BACKGROUND	9
RESEARCH METHOD & SCOPE	16
I. PREPARATIONS	
- The Working Site	21
- Documentation of Consolidation	27
- Program Development & Initial Design Guidelines	46
II. DESIGN EXPLORATIONS	
- Introduction	51
- Existing Block: EX	54
- Detached: Type 1	56
- Detached: Type 2	70
- Subdivision: Type 3	84
III. EVALUATIONS	
- Quantitative Analysis	87
- Qualitative Analysis	90
- Consolidation Standards	96
- Assessing the Standards	100
CONCLUSIONS	107
BIBLIOGRAPHY	109

ACKNOWLEDGMENTS

This study would not have been possible without the original support and sustained encouragement of my advisor Chester Sprague.

I would also like to recognize the interest of others who took the time to read and think with me on this subject, especially John N. Habraken and Denise Garcia.

And of course, I am grateful to my friends and family for their unwavering moral support throughout this endeavor.

BACKGROUND

The post war building booms of the 1950's and 1960's produced vast low density residential suburbs across the United States. These suburbs, composed largely of detached single family dwelling units, together with older suburban districts, now house 40% of the population and is the most popular form of housing in America.

There are signs that this tissue, at least in part, may soon undergo the process of consolidation, absorbing perhaps a major increase in unit density. Some of the reasons for anticipating this growth are as follows:

- A serious housing shortage nationwide.
- General concern over the environmental impacts of continued expansion of the suburban fringe, to accommodate growth.
- The presence of an underutilized infra-

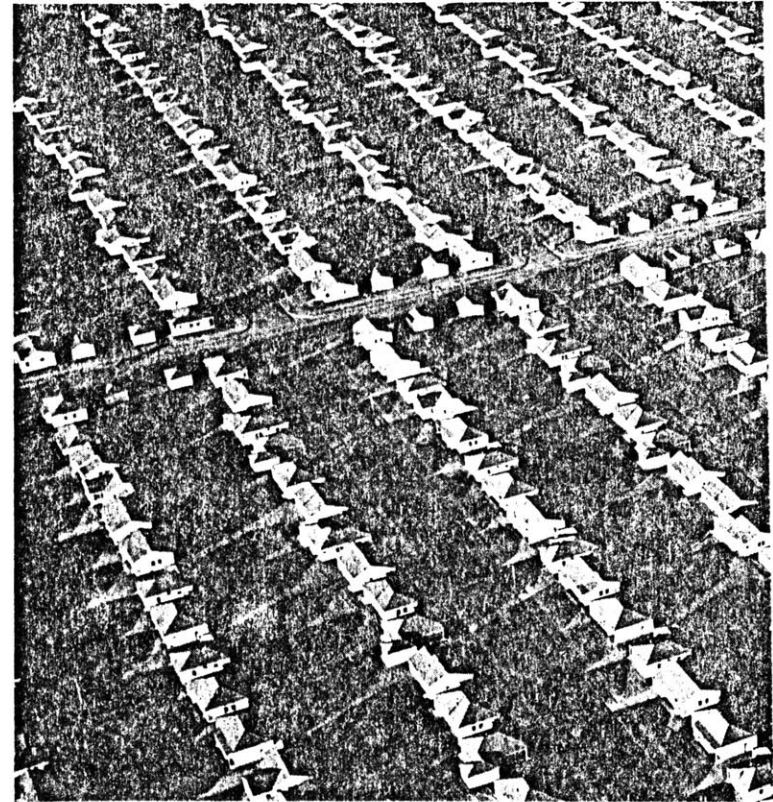

Lakewood, CA (1950) "17500 houses in 18 months"
Laurie, Michael.
Landscape Architecture

structure in these existing suburbs (utilities, sewer capacity, street & highway system, etc.).

- The growing number of underutilized dwellings in these existing suburbs due to the breakup of the nuclear family and other demographics ("empty nesters," single parents, shrinking family size, etc.).
- Our persistent economic problems (short money supplies, high interest rates, and a decade of high inflation).

Reuse of the existing housing forms is a likely strategy in any transformation of our suburbs because:

- The existing homes are generally in a good state of repair and can be a valuable resource.
- Reusing these homes can reduce construction costs per dwelling unit when compared to new construction.

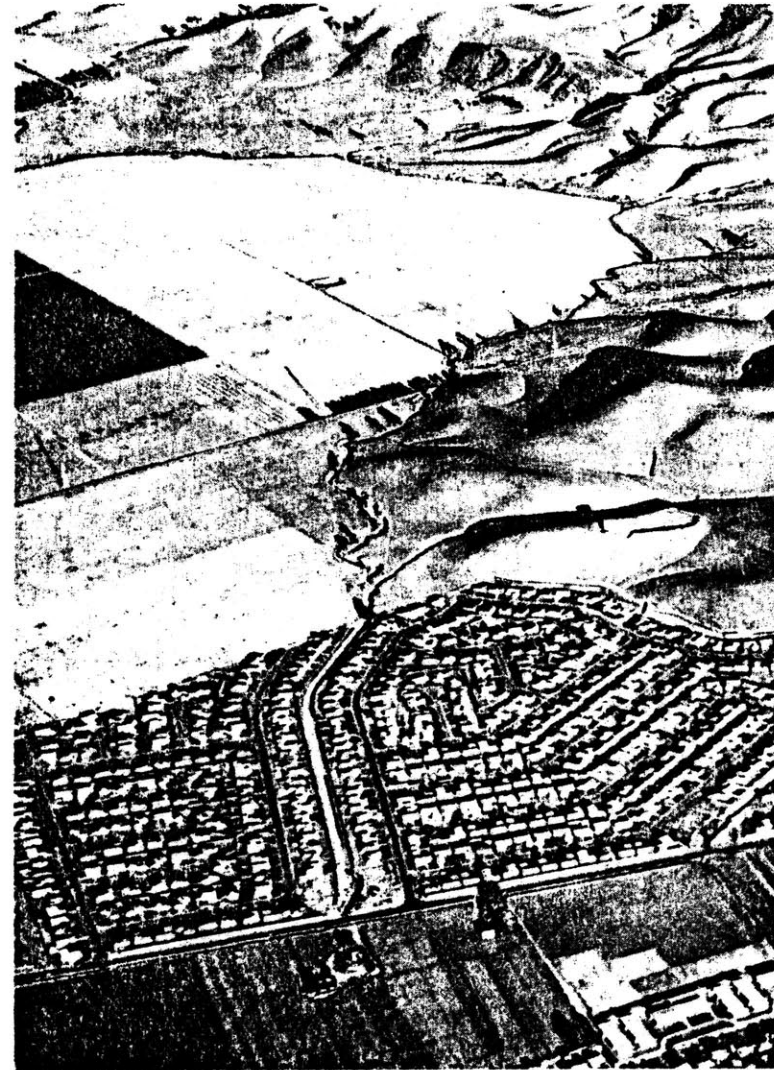

West Covina, CA (1952)
Laurie, Michael.
Landscape Architecture

- Concern over the negative environmental impacts that high density "apartmentlike" buildings can have on a low density host neighborhood favors conservation.

Consolidation involving conservation is certainly not without precedence. Intensified neighborhoods exist in many communities, however these districts often evolved under few regulatory constraints. In still other cases these developments were initiated illegally where planning policy did not recognize the real socio economic pressures driving this form of land use intensification. The environmental impacts that resulted from these consolidations were therefore mixed. Many neighborhoods were overwhelmed by unchecked growth. It becomes clear then that in order to insure favorable consolidation of suburbs, a coherent set of standards should be developed which can safeguard the intrinsic qualities of the host environment.

So far the arguments used for consolidation

have been purely economic. Some measure of environmental quality being sacrificed for economic gain is assumed.

However a neighborhood can gain in quality through consolidation as well. A few examples will illustrate my point.

THE FOUNTAINS

A 12-unit condominium development

Palo Alto, CA

Freebairn-Smith & Associates

This project joins two handsome detached single family homes together in a loose courtyard scheme.

Positive attributes:

- restoration of two architecturally significant structures through adaptive reuse.
- the addition of condominium type housing placed in this suburban context helps diversify the existing housing stock to match current housing needs.
- a pleasant courtyard space was an unprogrammed by-product of this project because conservation of the two existing structures was maintained as a given in the design process.

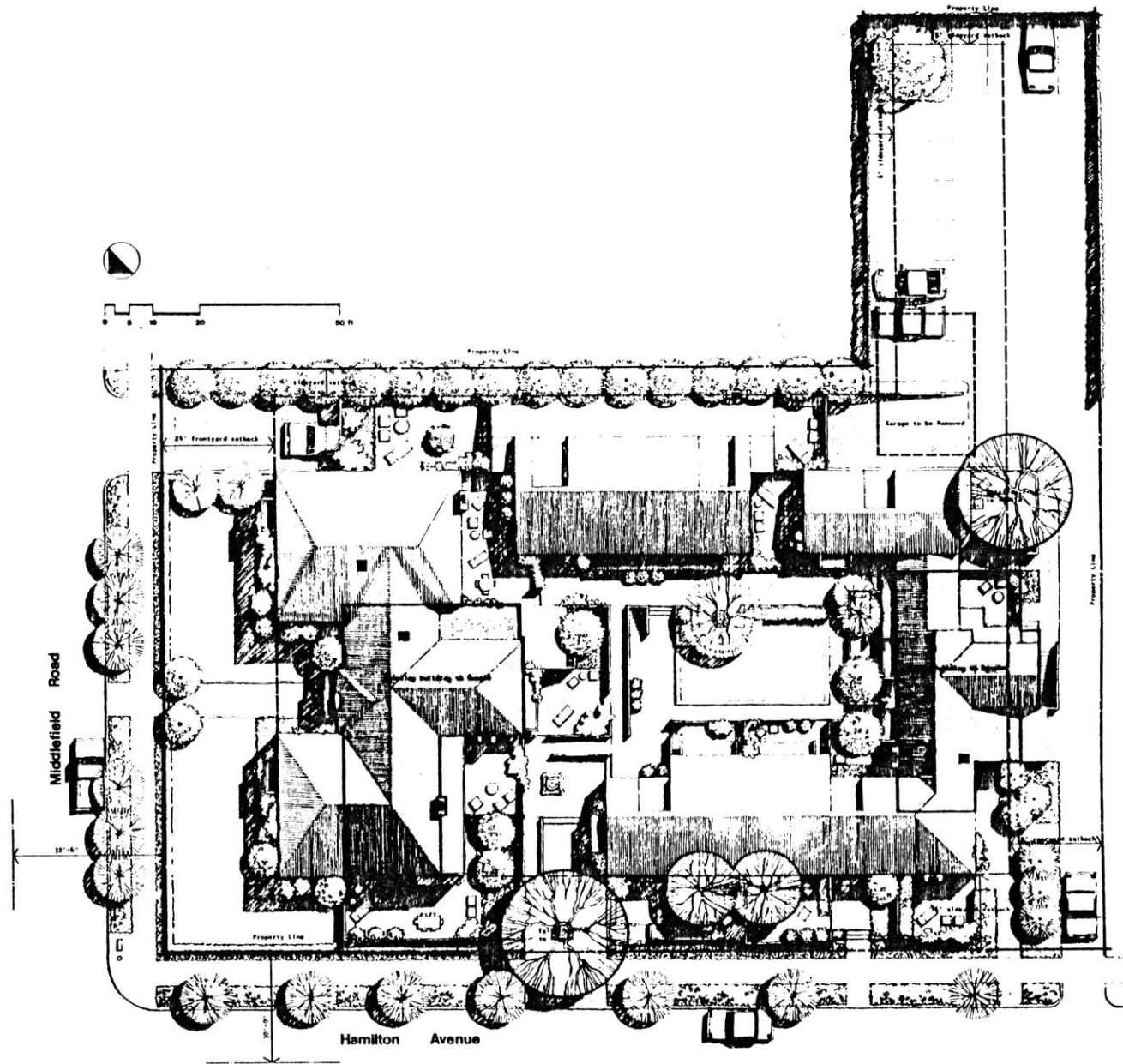

MRS. IVY'S GARDEN

A consolidated cluster of lots.
Berkeley, CA
From Building the Unfinished
(see bibliography)

The result of incremental growth covering a span of 30 years.

Positive attributes:

- The through block grouping of properties allows the possibility of a semipublic garden path across the block, providing a pleasant shortcut through a long block for pedestrians.
- The consolidation of the central portion of this block creates a number of new units which, unlike the existing homes, are buffered from street noise generated by cars.

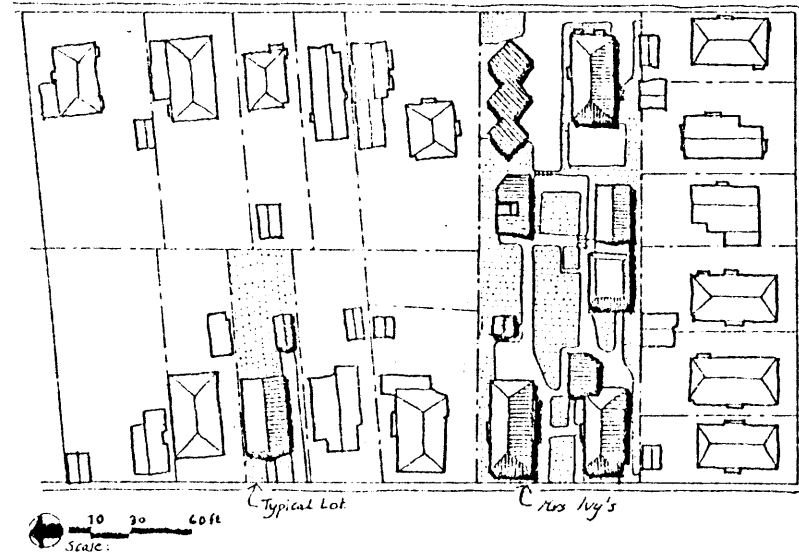

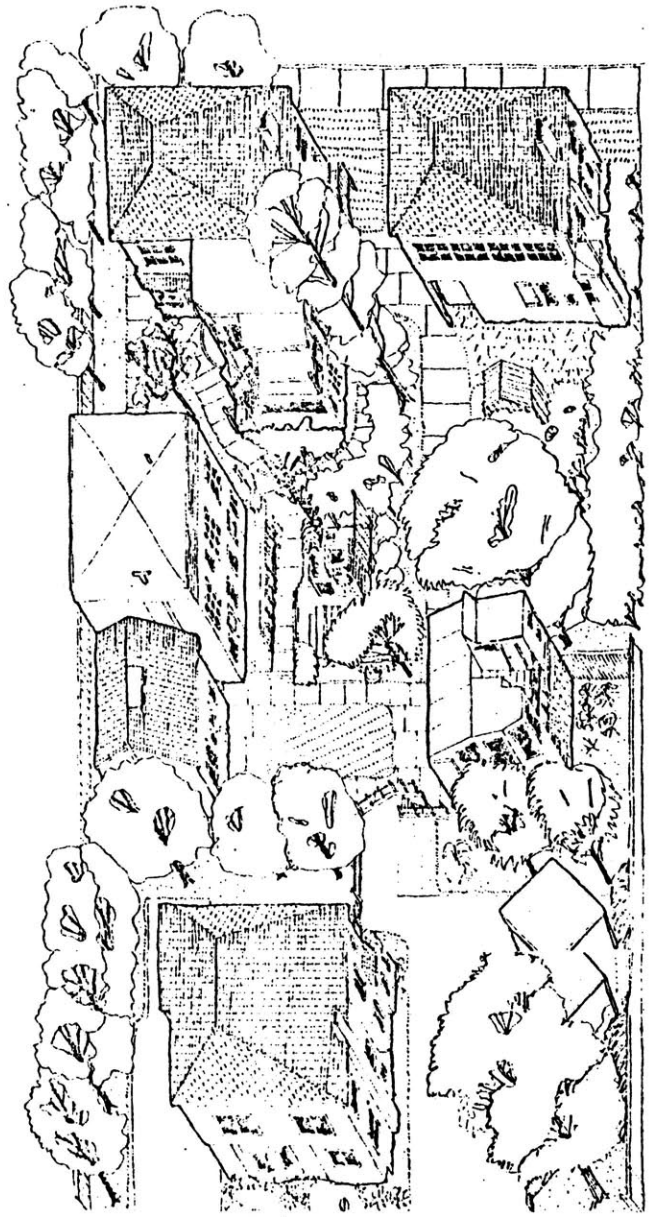
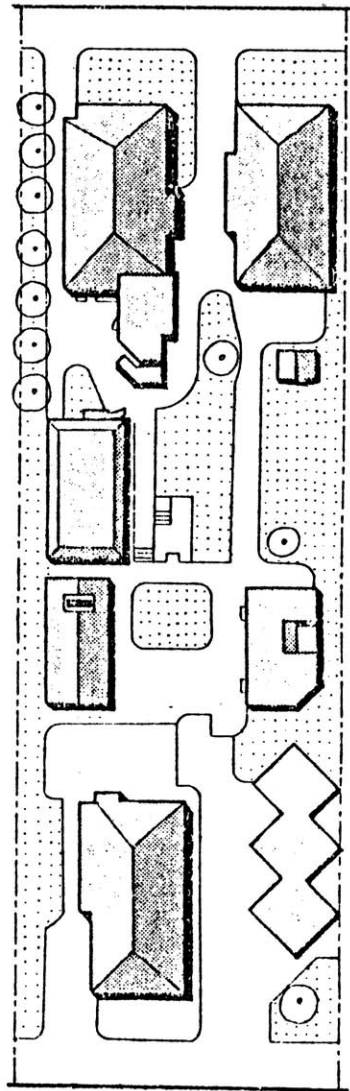
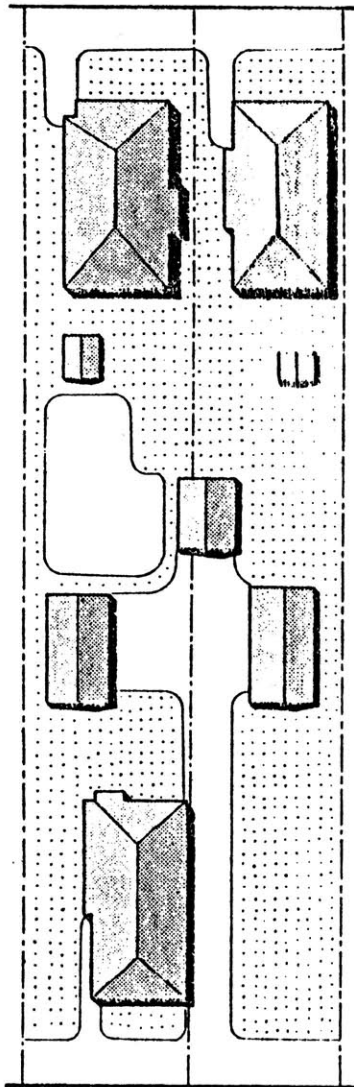

RESEARCH METHOD & SCOPE

This thesis follows closely the approach outlined by Chester Sprague & Anne Vernez-Moudon in their grant proposal of Dec. 1981 entitled CONSOLIDATION: A METHOD FOR EXPANDING THE USE OF SINGLE FAMILY HOUSING IN THE SUBURBS (see bibliography.)

There are three main bodies of work involved in this study. I. PREPARATIONS, II. DESIGN EXPLORATIONS, and III. EVALUATIONS.

I. PREPARATIONS

The preparatory work falls into three sub-categories.

1. Selection and documentation of the working site.
2. Documentation of existing examples of consolidation.
3. Program development and design guidelines.

The selection of the block used in this

study was, in part, due to my perception of it as having consolidation potentials. There was also the desire to generate consolidation standards that would be applicable to many suburban settings. Therefore the working site selection needed to be representative of a common block and development type. For the same reason I also avoided sites which contained unusually site specific elements such as extreme topographical features, special views, or mixed use patterns of development. A suburban block containing 30 dwelling units was chosen in Newton, MA which met these criteria. (See The Working Site, page 21 for specifics of the site.)

Documentation of the working site involved gathering unit plans, assessor's parcel maps, and aerial photographs of the block from the city of Newton Building Department. In addition to these materials field surveys, photo-

graphs of the surrounding streetscapes and building elevations were used to construct drawings which record the physical layout of the block, its dwelling units, and the positions of major landscape elements (trees, shrubs, and fencing) which dot the site. These drawings provided a base onto which various consolidation schemes were projected during the Design Exploration phase of the study. They also stored for easy retrieval, contextual data essential for the development of the consolidation standards in the Evaluation phase of the work.

Documentation of existing consolidation was carried out for several reasons. It became useful in the Design Exploration phase of this study to be operating under a set of design guidelines which would simulate on the working site patterns of consolidation (however gross) which reflect patterns that occur naturally in consolidated neighborhoods. Observation was necessary to establish these patterns.

A second reason for observing consolidated

districts was to catalog "successful" examples of land use intensification. This was useful in expanding my knowledge of possible architectural solutions to design problems typical of consolidation work. Existing consolidated areas of Berkeley, Ca were used as references. Examples of consolidation considered successful were those that met a design challenge associated with land use intensification without negatively impacting on the intrinsic qualities of the host environment. These issues include, for example, how to accommodate additional off-street parking without destroying the habitability of the open space, and how to provide circulation to new "backlot" units without creating visual privacy problems for existing "street" units. Finally, I felt it important to give to those readers unfamiliar with consolidated neighborhoods some visual images to supplement the bulk of this thesis which is primarily a site planning study.

In establishing a program for use in the Design Explorations some gross assumptions had to be made and maintained, so that useful

comparisons could be made between the various development schemes explored. For example, all units deployed were abstracted to a single footprint size and configuration, even though there is no intention on the part of the author to suggest that development should or would take on this uniform a pattern in reality. The initial program assumptions were formulated with the help of recent demographic data available to me in a report commissioned by the City of Newton entitled, POPULATION AND OPINION PROFILE: 1976-1980 TRENDS, Christopher Alexander's A PATTERN LANGUAGE, and as already mentioned, observations of consolidated neighborhood of Berkeley, CA. (See Program Development & Initial Design Guidelines page 46 for specifics).

II. DESIGN EXPLORATIONS

Consolidation can be categorized by both scale and type. The scale of consolidation refers to the number of original lots in a block that become linked together for joint consolidation. The type of consolidation refers to how the

new households physically relate to the existing structures. Together these two factors can be used to generate the following matrix of possibilities.

		SCALES OF CONSOLIDATION		
		Single Lots	Lot Clusters	Full Block
TYPES OF CONSOLIDATION	Subdivide Unit	X	0	0
	Addition to Unit	0	0	0
	Detached Units	X	X	X
	Combinations	0	0	0

X - explored in this thesis

0 - not explored in this thesis

Four of these combinations were selected for study. Subdividing units was an attractive possibility because many of the existing 3-4 bedroom dwelling units that make up the housing stock in this suburban context are underutilized. This type of consolidation was studied at the single lot scale and not in other scales because there seemed little to gain in aggregating lots in this instance. Because the specific block type under study here contains generous lots (100 ft wide x 150 ft deep & 50 ft wide x 150 ft deep) which can support new detached units, and because my observations of consolidation suggest the tendency to build new detached units in lieu of additions where possible, the detached unit "types" were favored for study over addition "types." The schemes involving combinations did not seem of primary importance since these could easily be imagined by studying the "types" making up a combination individually.

The purpose of the Design Explorations was twofold.

- To generate information about each develop-

ment scheme which make comparisons possible. This includes such data as unit counts and site coverages. This also includes the generic characteristics of each scheme such as settlement patterns, public circulation patterns, and parking distribution.

- To simulate the consolidated condition of the working site for each scheme so that the environmental impacts of unregulated consolidation could be examined.

III. EVALUATION

There are three ways that the information generated in the Design Explorations can be evaluated. A quantitative analysis can be made, a qualitative analysis can be made, and an evaluation of the generic patterns and characteristics exposed in the various schemes can be undertaken. Although I found it of interest to compile quantitative data on such issues as site coverages, and to illustrate some of the generic patterns and characteristics of each scheme explored, this was not

done in an attempt to suggest that any one type or scale of consolidation is more suited to this particular block type than another. To make such assertions one would need to undertake further study of such issues as unit costs and financing, marketability of new units, and the actual untapped capacity of the existing infrastructure, which fall outside the scope of this thesis.

Evaluative work concentrated on qualitative analysis, to further the main objective which was to outline a set of consolidation standards that would maintain the intrinsic "suburban" qualities of this particular tissue type.

Comparisons of the projected consolidation in each Design Exploration, with the unconsolidated working site produced a list of conditions which seemed to impact the site in a negative way. With this list in hand, the original design guidelines were reworked.

The new guidelines or "consolidation standards" now contained growth limiting factors which were designed to correct for the undesired consolidation generated in the

initial Design Explorations. These proposed consolidation standards were then used to adjust a selected number of the initial Design Explorations as a way of assessing their potency.

I. PREPARATIONS

The Working Site

The working site used in this study is a residential block in Newton, MA, bounded by Beethoven, Allen, Beacon, and Woodard Streets. More specifically, the 33 lot portion that extends from Beacon Street south to the playground that bisects the block.

This land was developed in two different periods and represents two settlement patterns.

The general characteristics of the property developed between the years 1930-1949:

- small lots (50 ft. wide x 150 ft. deep).
- two-story dwellings averaging 1500 sq. ft. each.

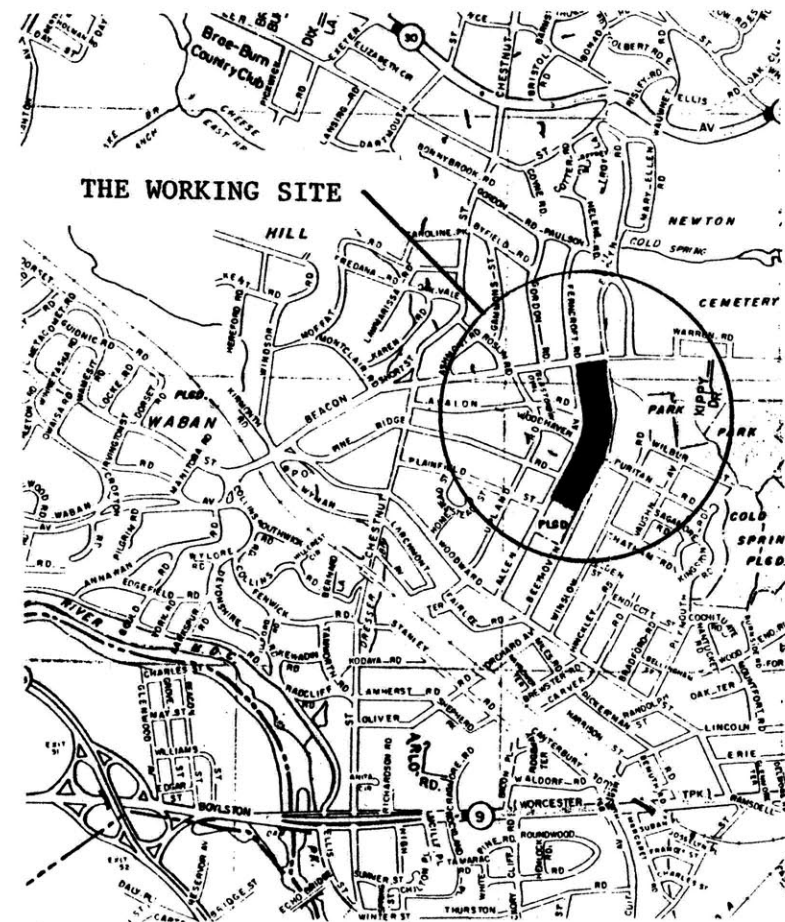

-
- no garages (cars parked on private drive-ways or street) or one-car garages.
 - 20 ft. building setbacks from front property lines.
 - sideyard building setbacks from property lines vary from zero to 12 ft.

The general characteristics of the property developed between the years 1950-1969:

- large lots (100 ft. wide x 150 ft. deep).
- one-story dwellings averaging 2000 sq. ft. each.
- two-car garages.
- 25 ft. building setbacks from front property lines.
- sideyard building setbacks from property lines vary from 8 ft. to 12 ft.

The topography of the block is generally flat, and minor elevation changes have been ignored for the purposes of this study. There is little in the way of native vegetation on the site, and the amount of landscape material that screens views across the site (evergreen trees, major shrubs, and solid fencing) varies. Some sections of the block are completely screened, but the majority is relatively open.

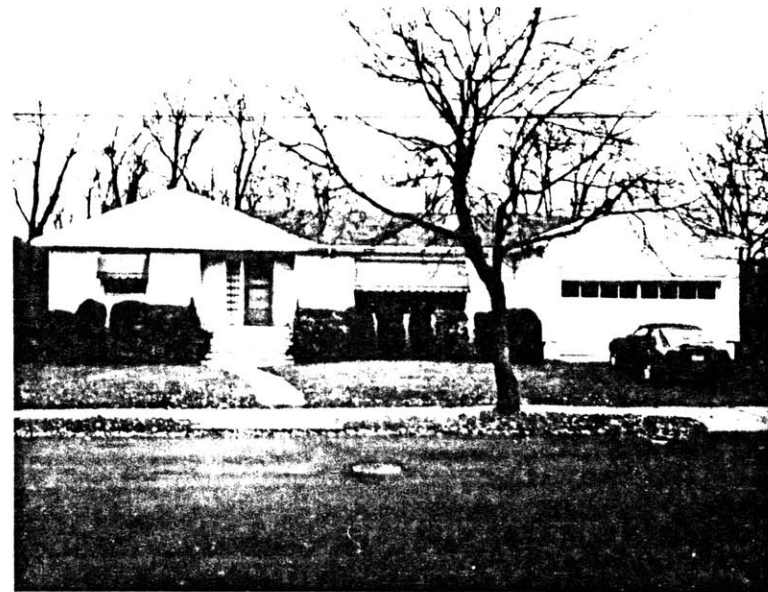





ONE-STORY UNIT TYPE

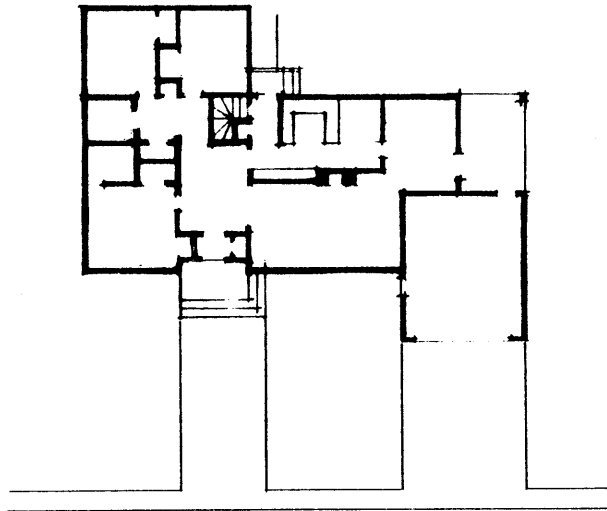

ground floor

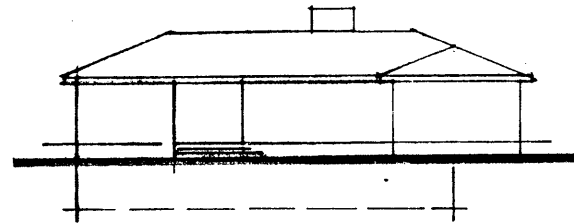

front elevation

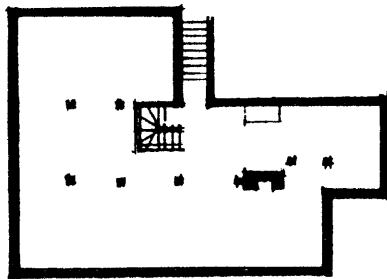

basement

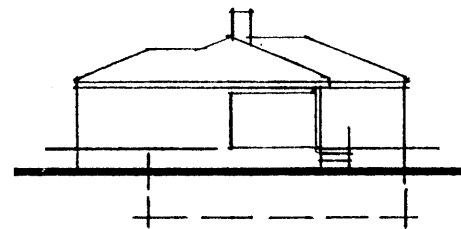

side elevation

TWO-STORY UNIT TYPE

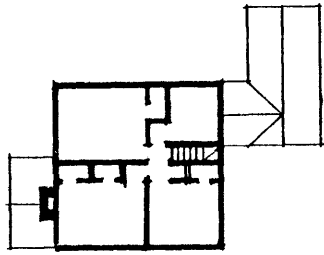
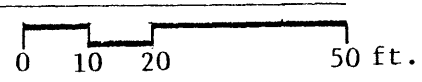

second floor

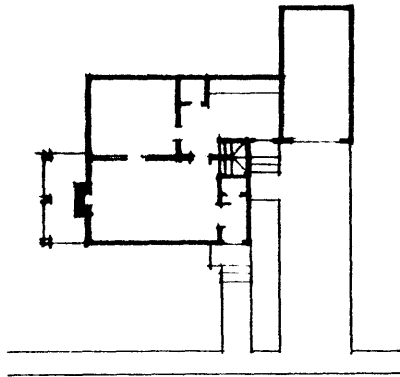

ground floor

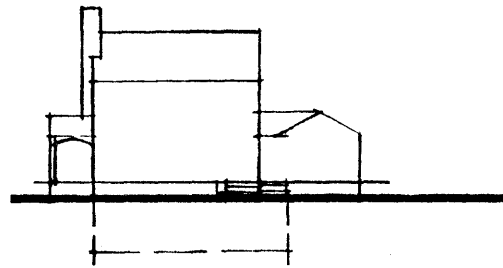

front elevation

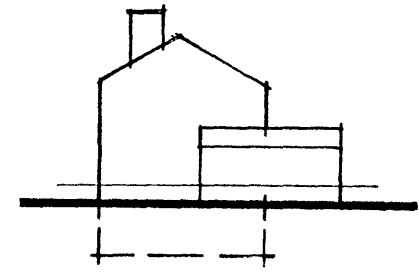

side elevation

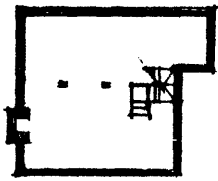

basement

Documentation of Consolidation

The photographs and site plans in this section record consolidated residential areas in Berkeley, CA. These are not a complete catalog of the vast numbers of intensified lots, but does give a representative sampling.

Comments note my particular interests in each. Each condition is labeled with the word PATTERN and/or EXEMPLAR. PATTERN indicates that the example shown was typical. EXEMPLAR indicates that I judged the particular adaptation as meeting a design challenge associated with consolidation without negatively impacting the intrinsic qualities of the host environment. A summary of my observations follow the illustrated examples.

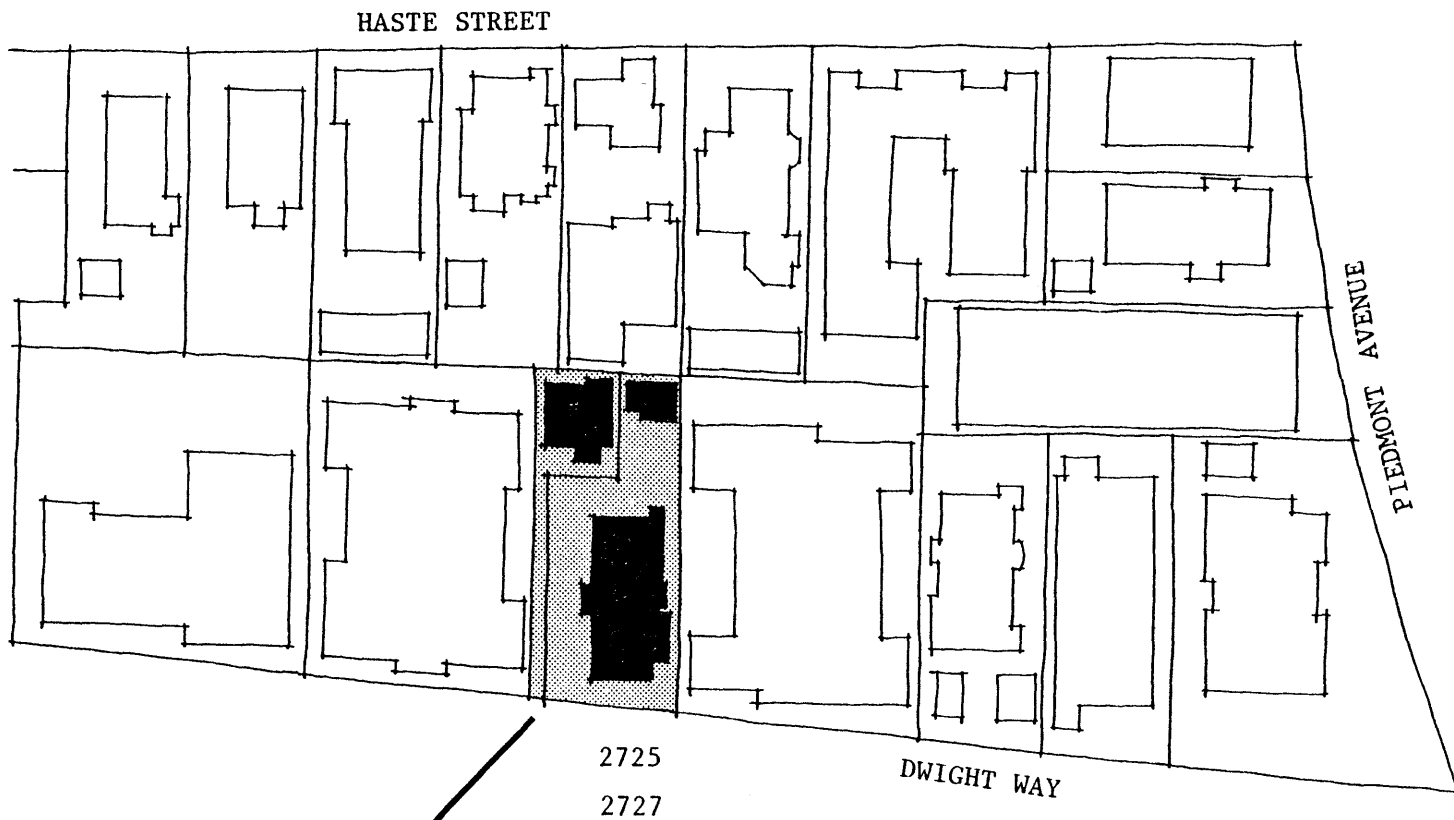

EXEMPLAR

"flaglot" cut out of original lot
allows "backlot" unit legal access
to public street and utilities.

2725 & 2725 DWIGHT WAY



PATTERN
EXEMPLAR
roof deck provides private outdoor
space where ground level is shared
by several units.

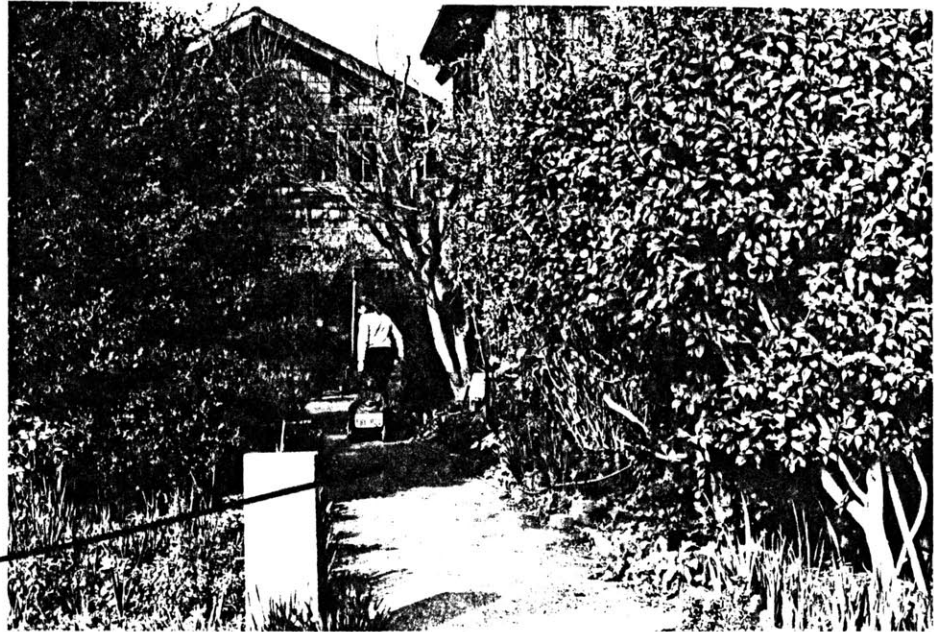

PATTERN
informal gravel path to "backlot"
unit.

2725 & 2727 HILLEGAS AVENUE

EXEMPLAR
porch roof becomes a deck for upper
level flat.



EXEMPLAR
architecturally integrated second
entry doesn't become a "sore thumb."

2629 A, B, & C PIEDMONT AVENUE

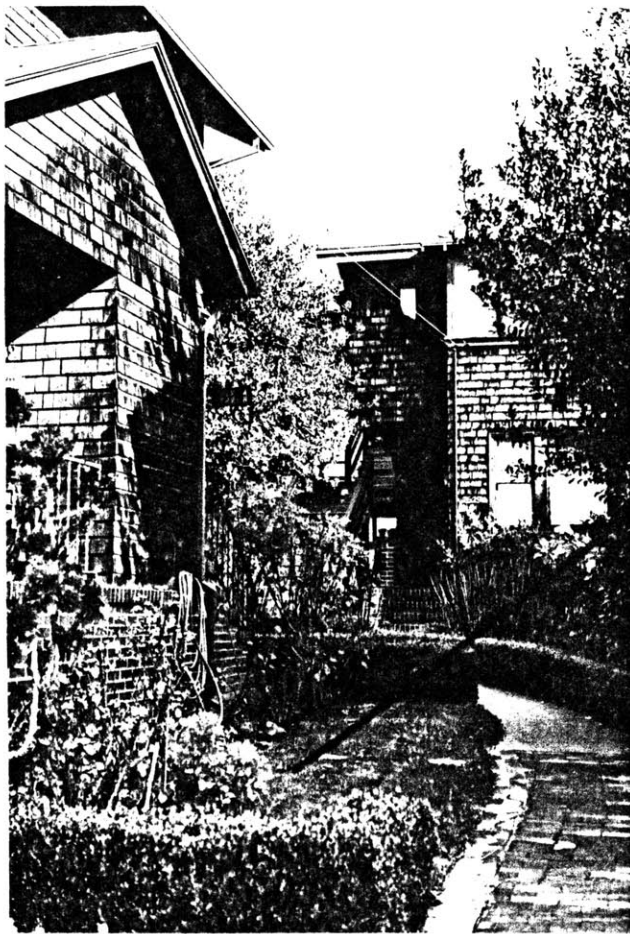

EXEMPLAR
landscape buffer maintains visual
privacy for "street" unit dwellers
by distancing pathway to "backlot"
unit from window openings.

2335, 2337, & 2339 BLAKE STREET



EXEMPLAR

pathway to cottage controlled at street with fence and gate, makes yard space more private.

EXEMPLAR

onsite car storage placed under unit to minimize intrusion on limited outdoor space.

2009, 2011A & 2011B LINCOLN STREET

PATTERN
EXEMPLAR
roof deck provides private outdoor
space



EXEMPLAR
solid fencing screens parked cars
from view.

2017, 2019, & 2021 VINE STREET - 1446 HENRY STREET

EXEMPLAR

addition of porch-deck addition
benefits both upper and lower flats.
Upper level gains outdoor living
space. Lower level gains sheltered
entry.



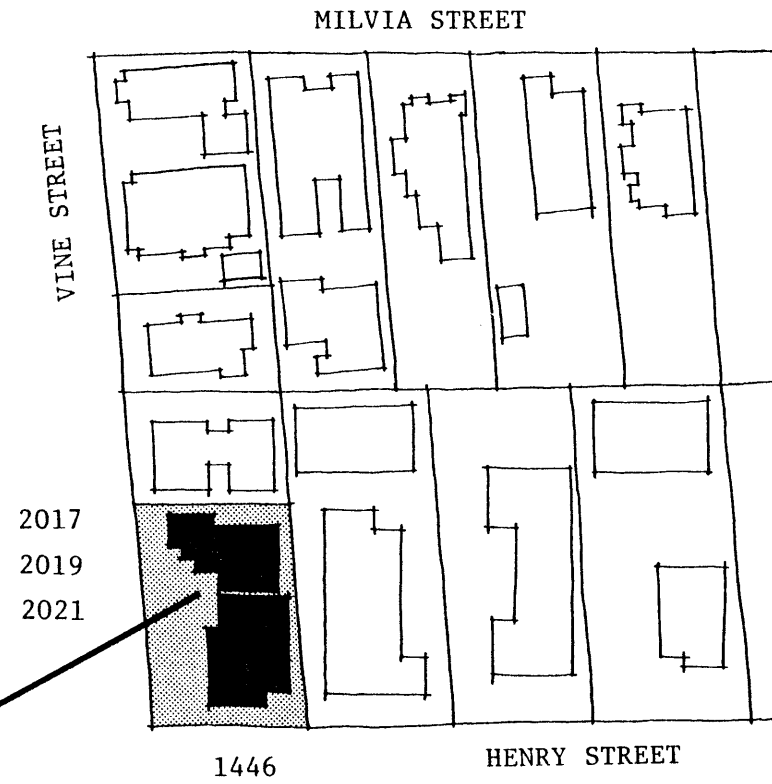

PATTERN
 consolidation of tight lot takes the
 form of an addition rather than de-
 tached unit.

2532 & 2532½ ETNA STREET

EXEMPLAR
gate provides security and privacy
when driveway not in use.

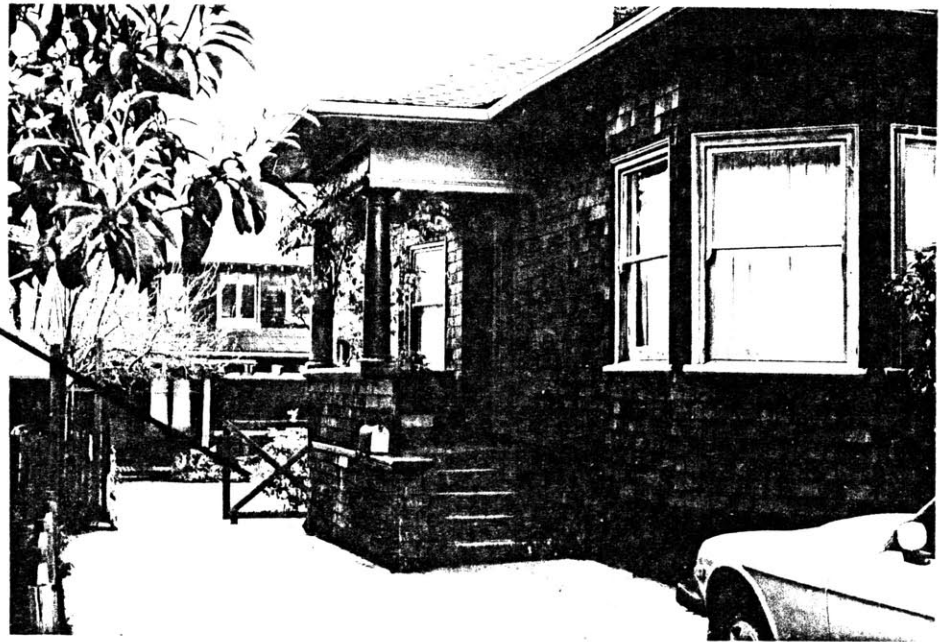

2532 & 2532½ ETNA STREET



PATTERN
drapes remain open on "private" side
of unit only.

PATTERN
drapes drawn on "public" side of
unit where no other buffering device
provided.

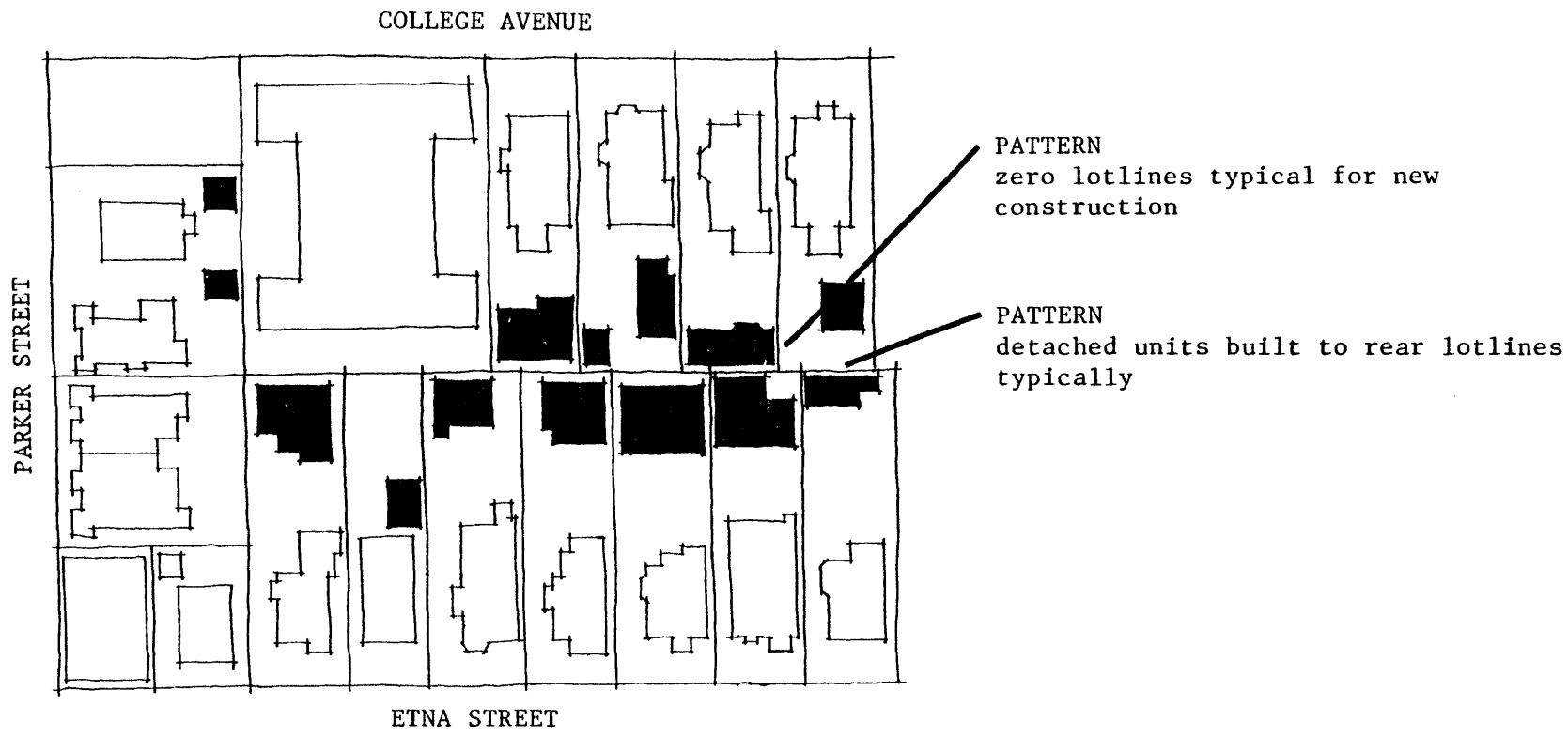

ETNA STREET

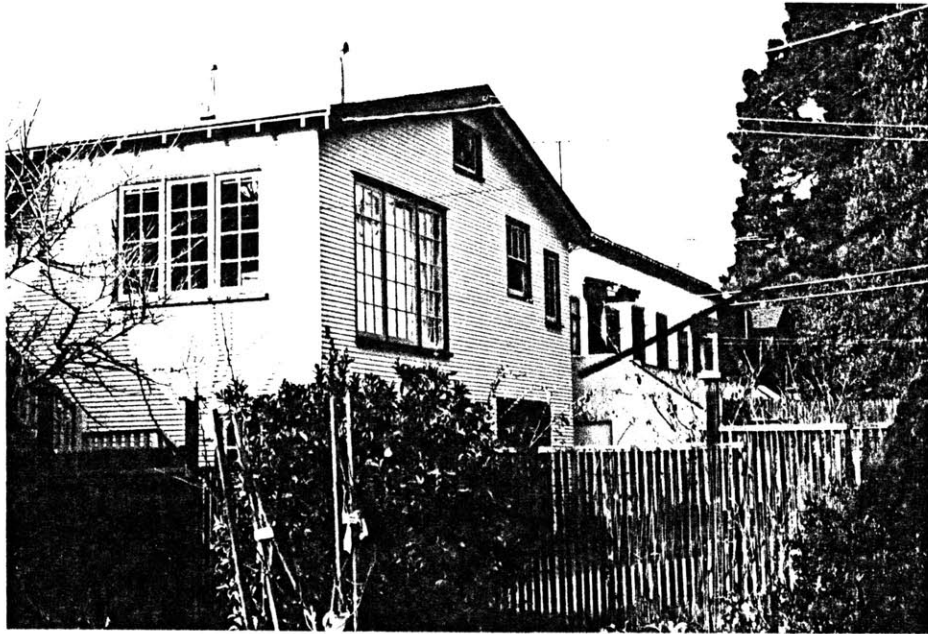

PATTERN
zero lotlines typical of consolidation

2526 & 2530 ETNA STREET



PATTERN
EXEMPLAR
stacking apartment units over parking
garages saves open space .

2526 & 2530 ETNA STREET



PATTERN
"backlot" units face street typically,
and are positioned to look out to the
street down sideyards where possible.

2518 & 2518½ ETNA STREET



PATTERN
zero lotline development



PATTERN
"backlot" consolidation can be so
discrete that special signage is
sometimes required for identification.

2327, 2327A, 2329, 2329½, 2331, 2331A, & 2333 DWIGHT WAY

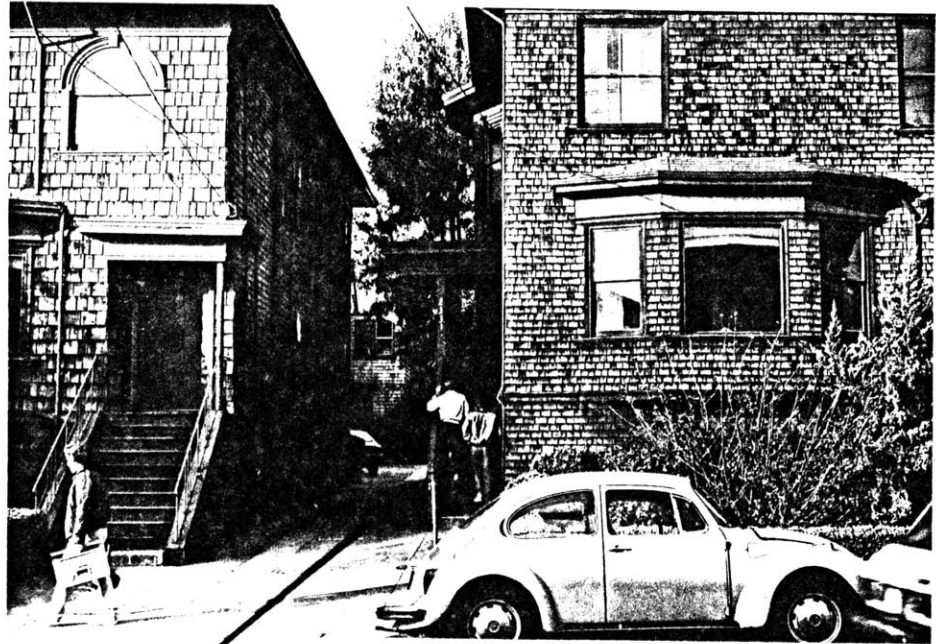

PATTERN
EXEMPLAR
pair of lots share driveway which
strattles property line

2822 & 2826 HILLEGAS AVENUE

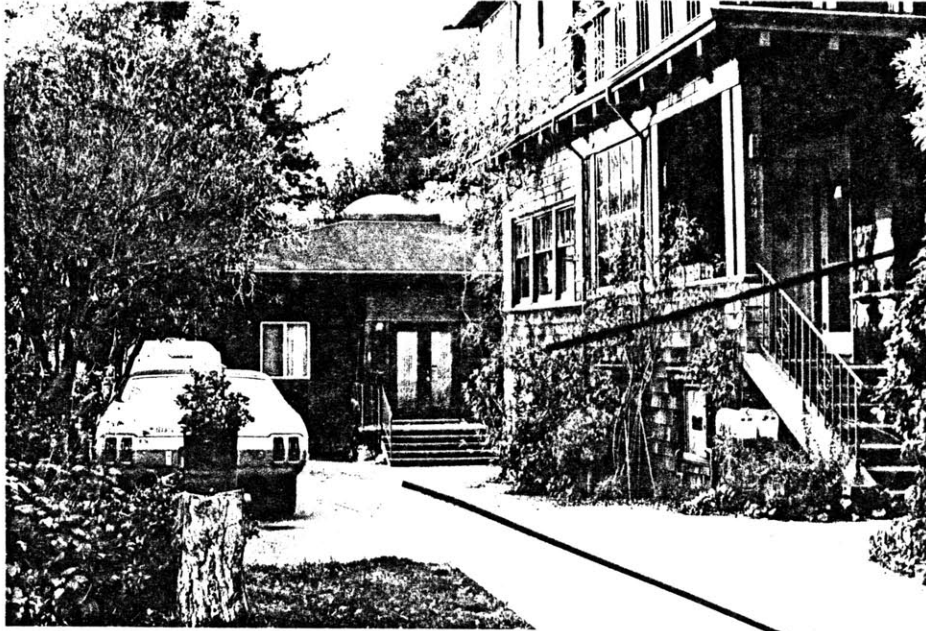

PATTERN
EXEMPLAR

elevation change between living space of "street" unit and ground level places eyelevel of passers-by below window sills, permitting pathway to run close to building without visual privacy conflicts.

EXEMPLAR

good quality aggregate finish on this driveway makes it reasonable as a patio. (tenants use as BBQ area)

SUMMARY OF OBSERVATIONS

- Internal subdivision of large dwelling units is common.
- If the lot is large enough there seems to be a tendency to build detached units rather than building major additions to increase the number of households on the lot.
- Secondary structures tend to be located as far from the primary unit as possible. A zero lotline is used in many cases.
- Landlords that live on consolidated property generally occupy the "street" units.
- Secondary units are generally smaller in size and of lower quality construction than the primary units.
- The outdoor living space remaining after consolidation tended to be shared by all the households occupying the lot. Few examples had the outdoor space divided into smaller private yards. Two-story units and upper level flats generally had small private decks.
- Adjacent lots with narrow sideyards sometimes jointly developed this space into a shared driveway in order to access "backlot" space otherwise inaccessible for parking.
- Visual privacy for "street" unit dwellers, from those walking along their windows on their way to "backlot" units, is maintained by blocking window openings with shades or drapes when distance, elevation changes or landscape buffers are not possible.

Program Development & Initial Design Guidelines

Included in this section:

- An outline of the program assumptions that lead to the formulation of the two building types used in the Design Explorations.
- Diagrams of these two building types (Detached: Type 1 and Detached: Type 2).
- A list of the rules governing their deployment on the working site in the Design Explorations.

Program Assumptions

Because the goal here was to study a general, not specific, design problem it made no sense to use a specific unit mix. In its place the building forms generated in the detached type consolidation studies were generated from a single base module of living space.

With a module of 700 sq. ft., dwelling unit sizes of 700 sq. ft., 1400 sq. ft. and 2100 sq. ft. could be represented by grouping together base modules. A single building footprint module size was maintained for consistency.

The introduction of a design module also simplified the quantitative comparisons. For example, dwelling unit counts could be stated as the number of 700 sq. ft. modules deployed, which is more useful, in this general a study, than would unit counts by type.

One of the patterns observed in the consolidated areas of Berkeley was the introduction of private outdoor deck space to take the place of private yard space lost in consolidation. Christopher Alexander's A PATTERN

LANGUAGE also strongly encourages the introduction of outdoor living space in residential settings (Patterns 163 & 167). I also believe that there is a high expectation for this kind of close relationship with the outdoors, in a "suburban" setting, therefore some measure of private outdoor living space was provided for each 700 sq. ft. of indoor living space deployed.

Ground floor units were given a minimum private use yard, 20 feet deep x 30 feet wide. Upper level units were assumed to have small sun decks (6 ft. deep x 6 ft. wide) to satisfy this requirement.

Another pattern observed in Berkeley was that secondary detached units were generally smaller in size than the primary structures.

The primary settlement pattern of the block type under study here is a combination of one and two-story homes, therefore the building types used in this study do not exceed two stories.

Zero lotline deployment of new detached units was a pattern of consolidation in Berkeley, and is used as a strategy in the guidelines which follow. Because of this assumption, unit module footprints were sized so that the space would be habitable if/when abutted by other units. Abutting units reduces the amount of glazable and/or ventible surface area .

Parking was provided in the ratio of one space per 700 sq. ft. of new living space. In the case where existing units were being subdivided, one space was provided for each resulting unit. These figures were my guestimate of a reasonable number of parking spaces to be responsible for.

All new parking spaces were assumed to be provided on site, a pattern typical of most suburban contexts.

Exception: units accessed by a new street cut through the block could have their spaces provided along this new street as long as guest parking in the ratio of one guest

space per 2800 sq. ft. of living space (4-unit modules) were also available.

Diagrams of the two detached building types generated by the program assumptions follow.

DETACHED: TYPE 1

1400 sq. ft.

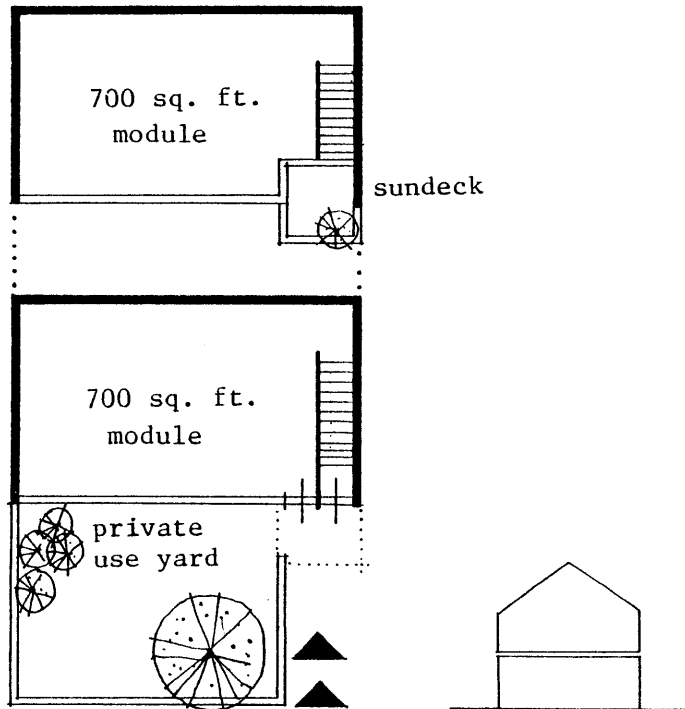

DETACHED: TYPE 2

700 sq. ft.

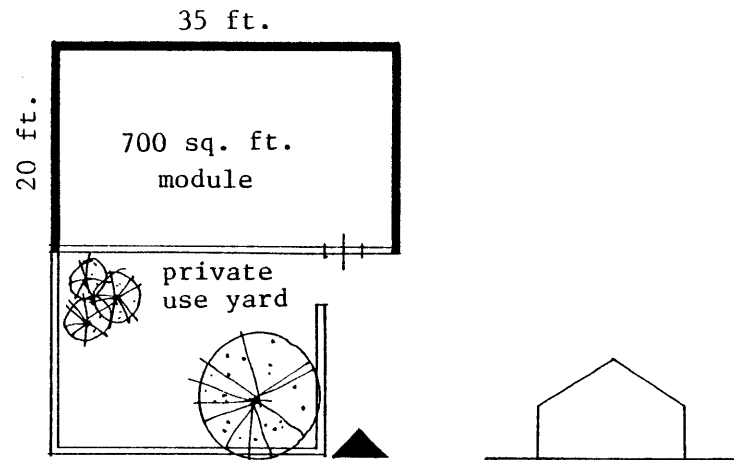

Initial Design Guidelines

1. Construction costs are lower per sq. ft. if several small dwelling units are grouped into larger buildings (less insulation, less exterior sheathing, less mechanical work, etc.), therefore unit modules of 700 sq. ft. were grouped into larger structures whenever possible.
2. A pattern noted in the detached type consolidation of Berkeley was the tendency to locate new structures as far as possible from the primary dwellings. Zero lotline development along rear and side yards. This pattern was adopted as an initial design guideline.

3. It was further decided that no new structures should fall within a 30 ft. building setback from the existing dwellings.

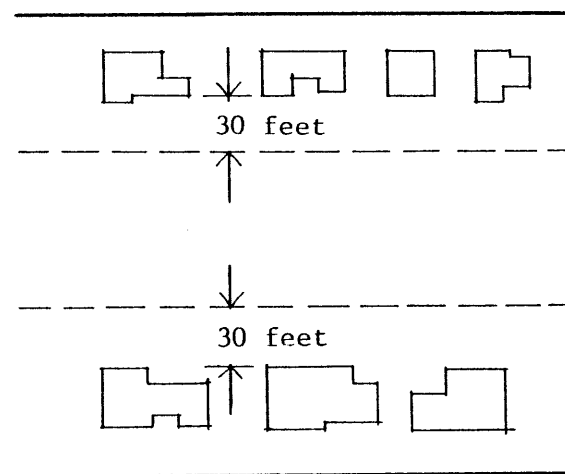

4. The diagrams below illustrate the minimum building setback requirements between new units.

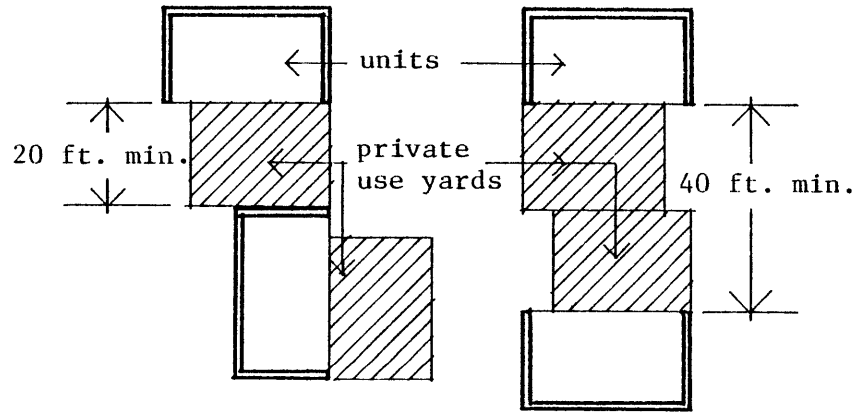

5. Parking, as already indicated in the Program Assumptions, was to be provided on site. New parking spaces were also to be associated with the existing driveways and utility areas present on the site, whenever possible.

6. The dwelling unit capacity of each development scheme studied in the Design Explorations was to be maximized within the design guidelines prescribed above.

II. DESIGN EXPLORATIONS

Introduction

There were four general consolidation approaches selected out for study, from the matrix of possibilities presented in RESEARCH METHOD & SCOPE, page 16. These were further expanded into a list of fifteen specific developmental approaches using three "types" and seven "scales" of consolidation. The "types" have been designated with the numbers 1, 2 & 3, the "scales" with the letters A, B, C, D, E, F & G.

The following outline briefly describes each of these and relates them back to the original matrix.

TYPES OF CONSOLIDATION

Detached: Type 1

- Adding new two-story detached structures.
- Footprints 20 ft. x 35 ft.
- 1400 sq. ft. of living space each (counted as two dwelling units of 700 sq. ft. each).

Detached: Type 2

- Adding new one-story detached structures.
- Footprints 20 ft. x 35 ft.
- 700 sq. ft. of living space each (counted as one dwelling unit).

Subdivision: Type 3

- Subdividing the existing dwelling units into smaller units.

SCALES OF CONSOLIDATION

Single Lots

- All existing lots consolidate independently

A - Existing lots

E - Existing lots with full block easement *

Lot Clusters

- All existing lots aggregate their land into a number of larger units that consolidate independently.

B - Lot groups along street

C - Lot groups through the block

D - Larger lot groups combining aspects of B & C above.

Full Block

- All existing lots collectively aggregate a portion of their land for joint consolidation.

E - Existing lots with full block easement*

F - One large band of land

G - Two narrower strips of land.

* "E" has been listed under both the Single Lot and Full Block categories because it has some of the characteristics of both scales.

The following is a list of the fifteen combinations used in the Design Explorations.

1A	2A	3A
1B	2B	
1C	2C	
1D	2D	
1E	2E	
1F	2F	
1G	2G	

Each Design Exploration is presented graphically on two pages. The left-hand page shows an overall site plan. Keyed to this are three site sections. Sections A-A & B-B are cut through the block and illustrate the most congested and most open conditions present in the scheme. Section C-C, cut through a portion of Allen Street, illustrates the visual impact that the projected consolidation would have on the neighborhood. This particular street section was chosen because I wanted to indicate the worst case for criticism, and the existing one-story structures here provide this.

On the right-hand page, site diagrams illus-

trate the land aggregation assumed, and the public circulation, settlement, and parking distribution patterns generated.

The existing unconsolidated site has been presented in this section using the same format so that comparisons with the Design Explorations could be made more easily. The unconsolidated site has been designated "EX".

EX

Overall Site Plan

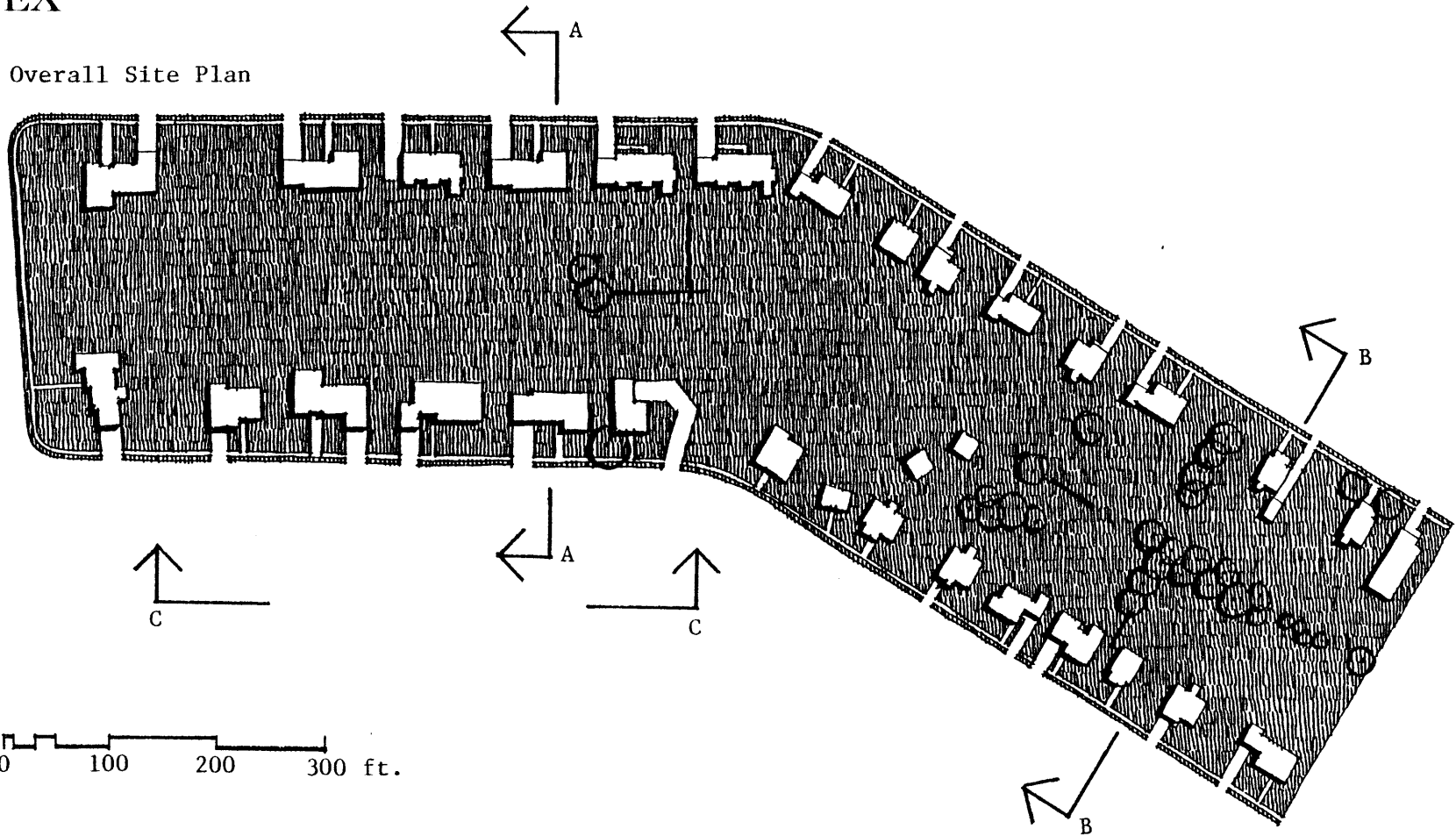

Section C-C

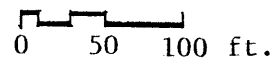

Land Aggregation Assumed

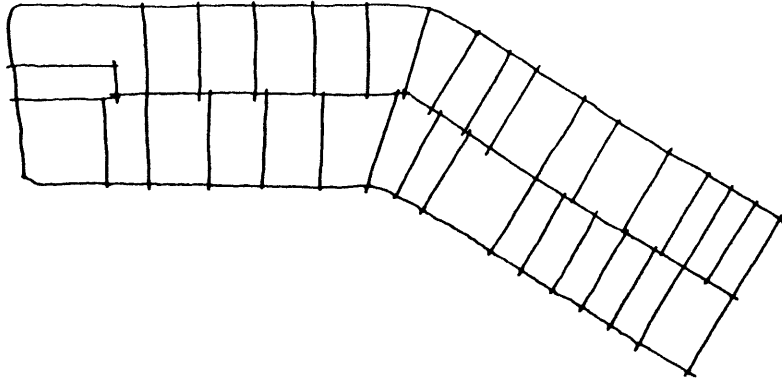

Public Circulation Patterns Generated

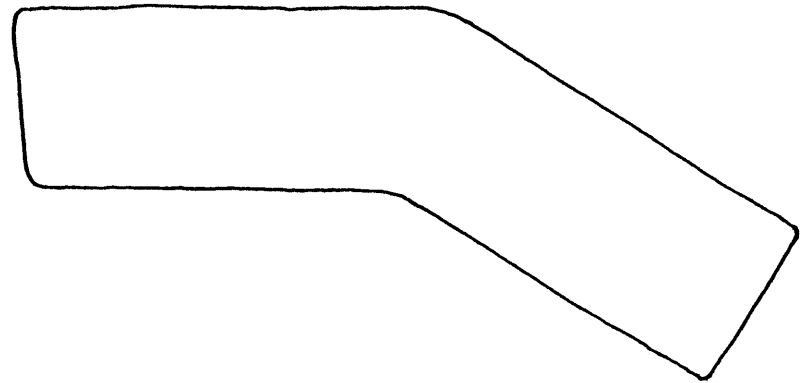

Settlement Pattern Generated

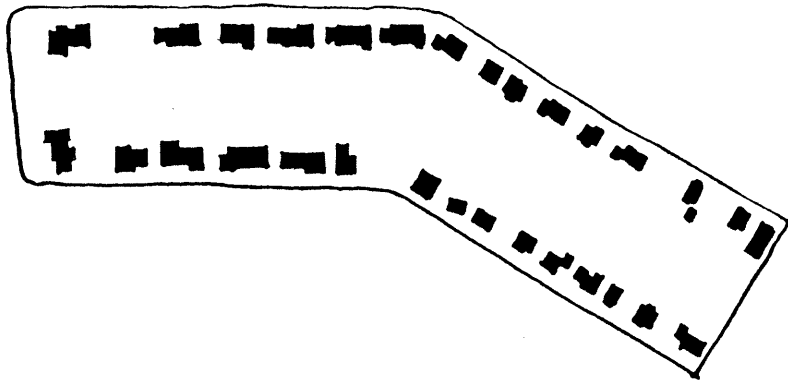

Parking Distribution Generated

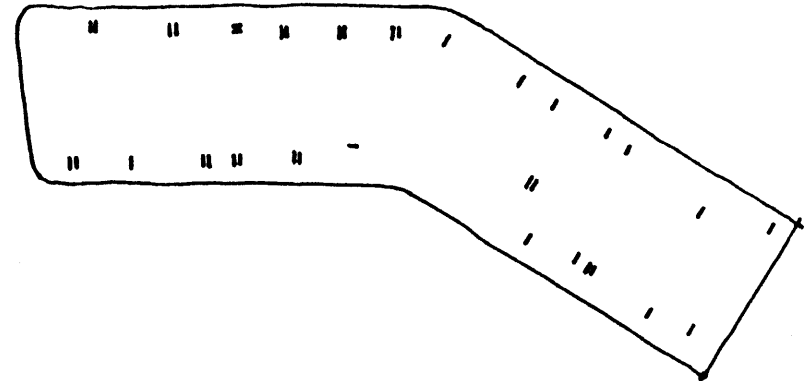

Section A-A



Section B-B



1A

Overall Site Plan

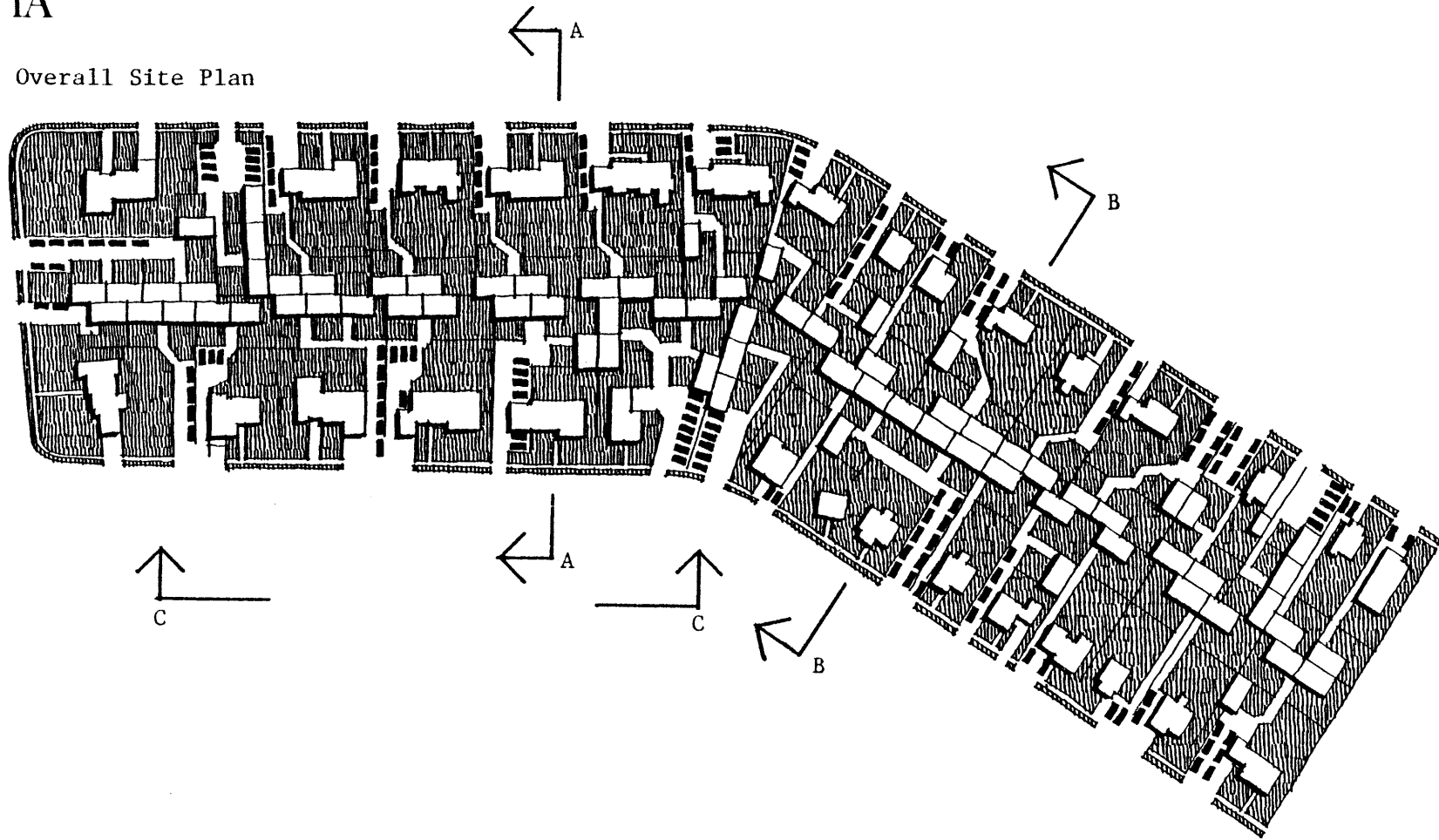

Section C-C



Land Aggregation Assumed

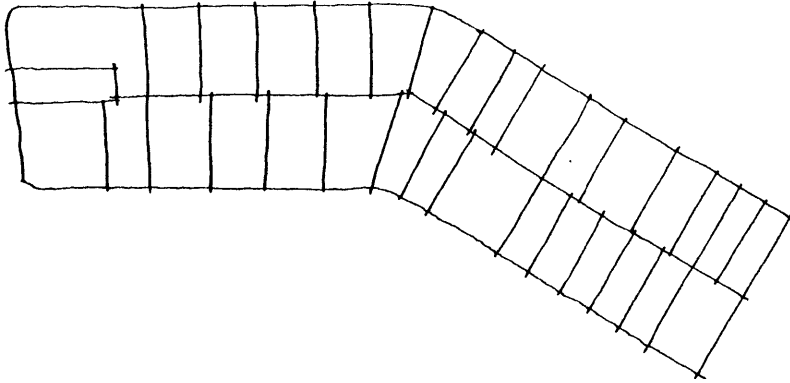

Public Circulation Patterns Generated

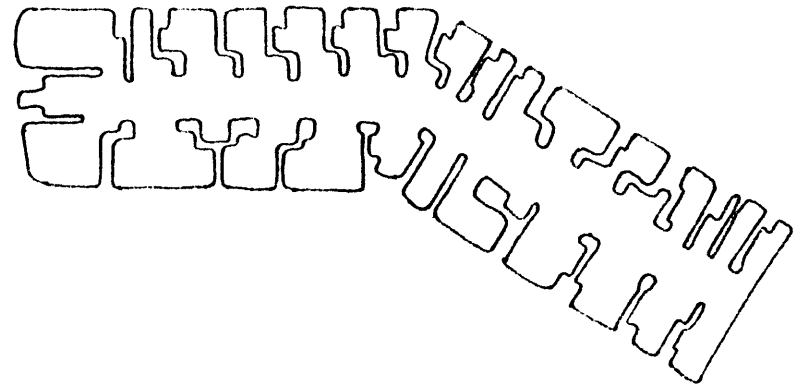

Settlement Pattern Generated

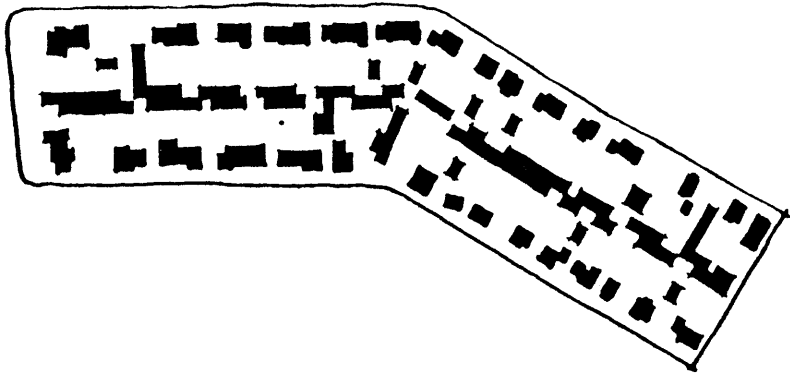

Parking Distribution Generated

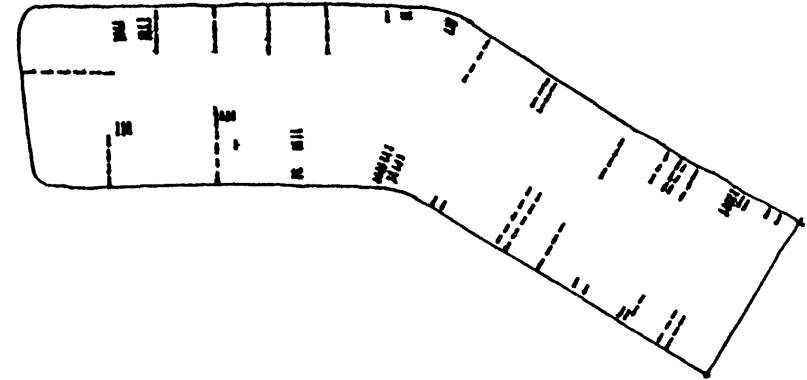

Section A-A



Section B-B



1B

Overall Site Plan

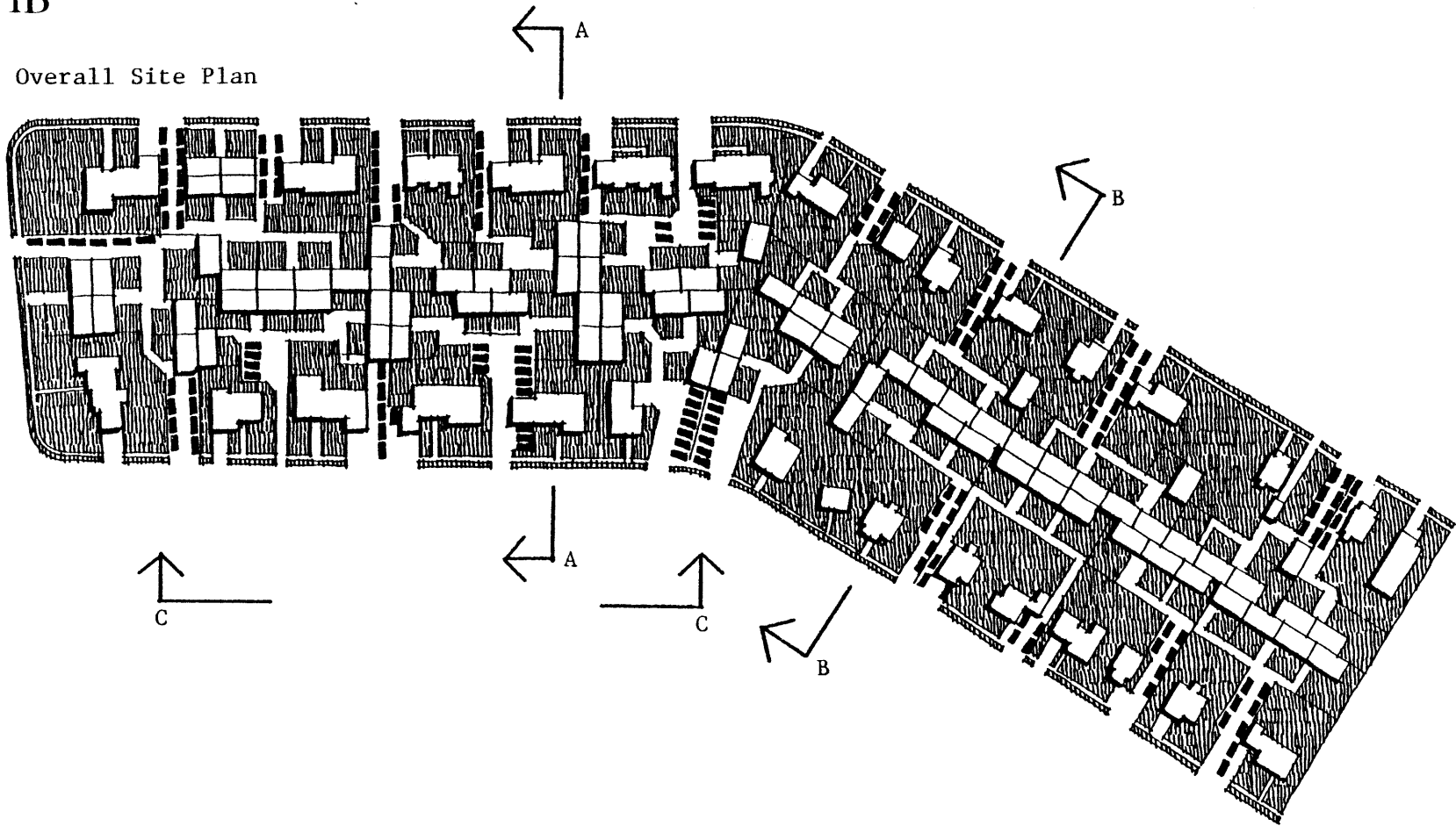

Section C-C

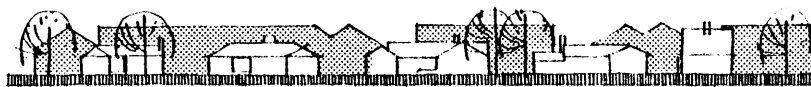

Land Aggregation Assumed

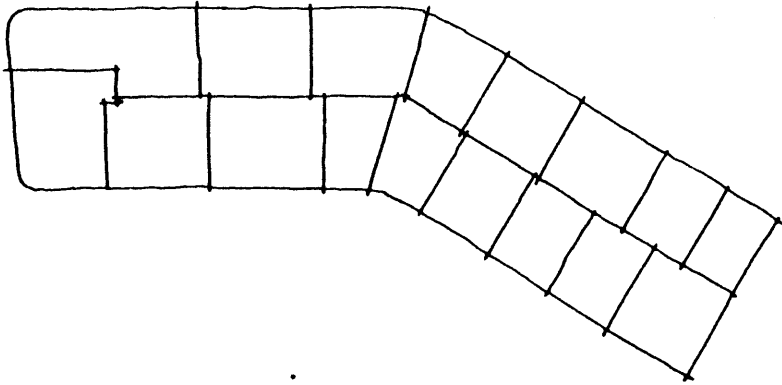

Public Circulation Patterns Generated

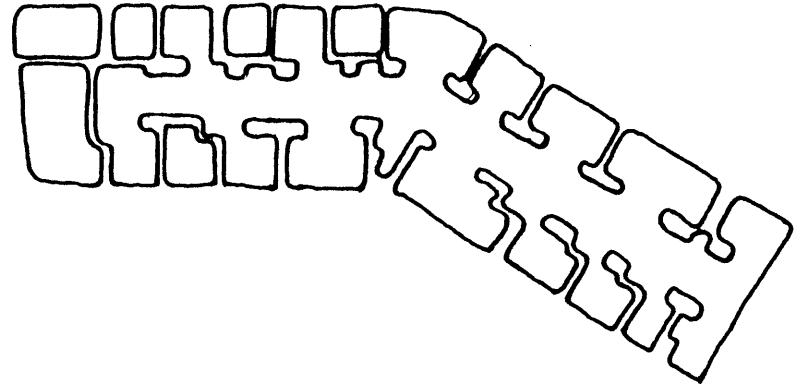

Settlement Pattern Generated

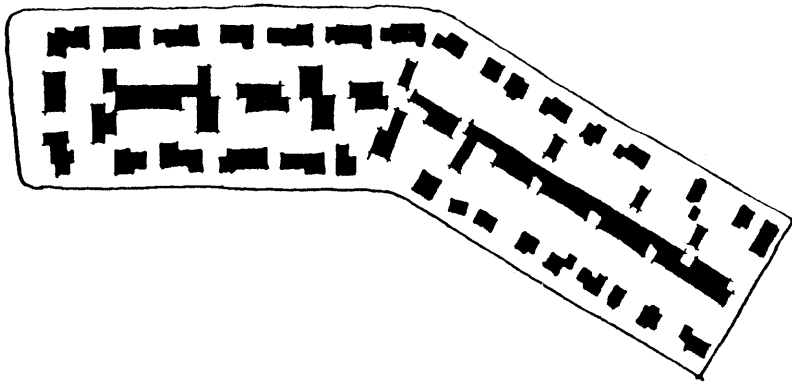

Parking Distribution Generated

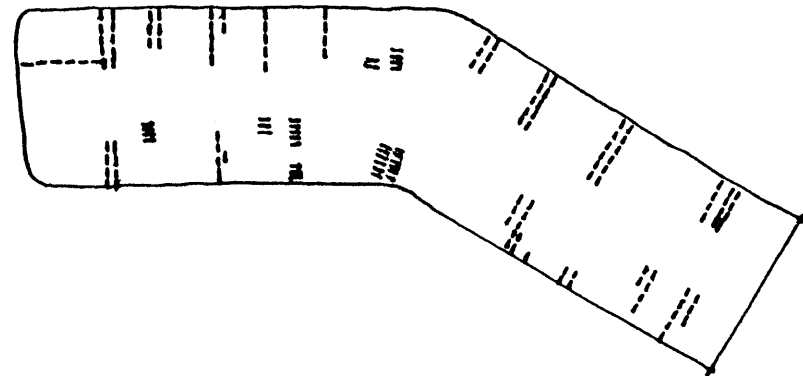

Section A-A



Section B-B



1C

Overall Site Plan

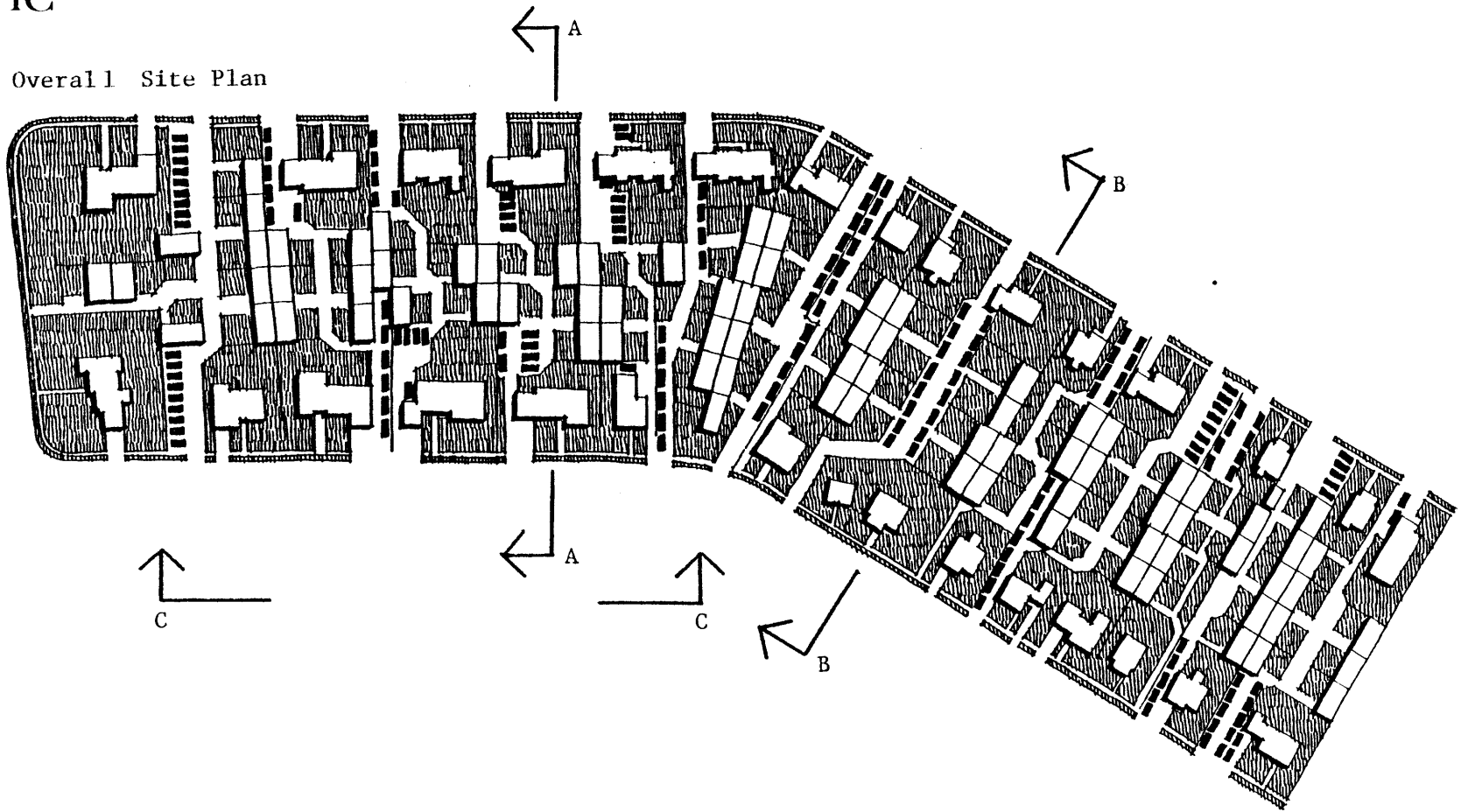

Section C-C



Land Aggregation Assumed

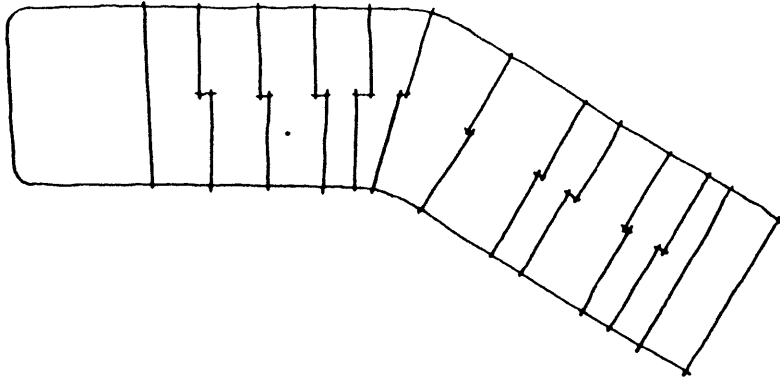

Public Circulation Patterns Generated

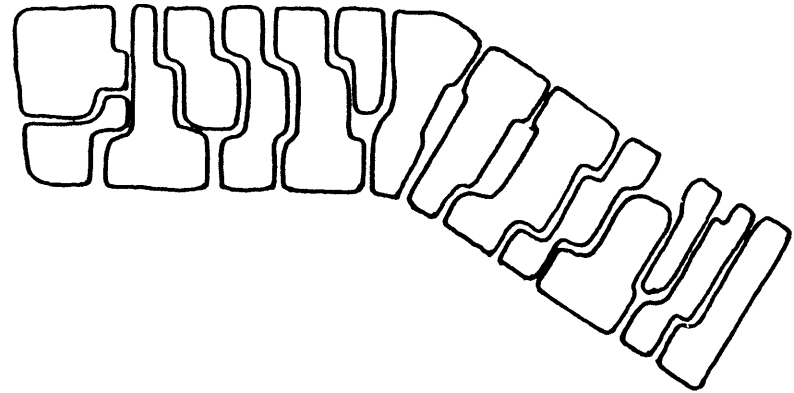

Settlement Pattern Generated

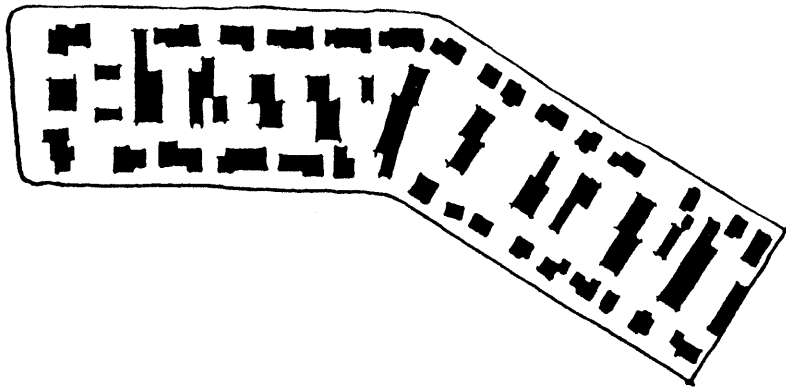

Parking Distribution Generated

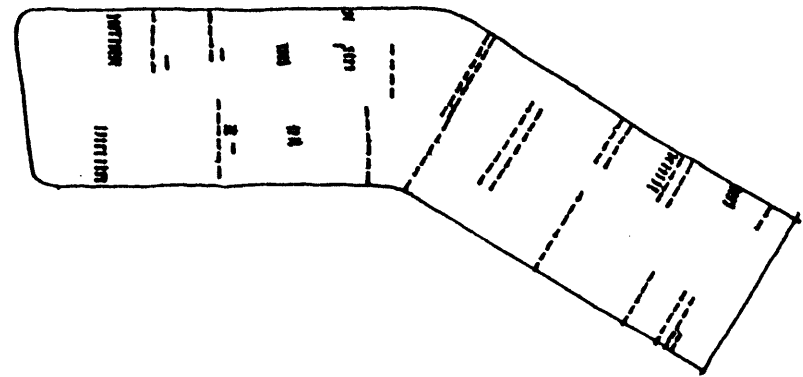

Section A-A



Section B-B

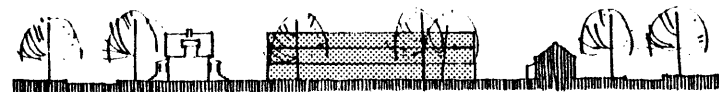

1D

Overall Site Plan

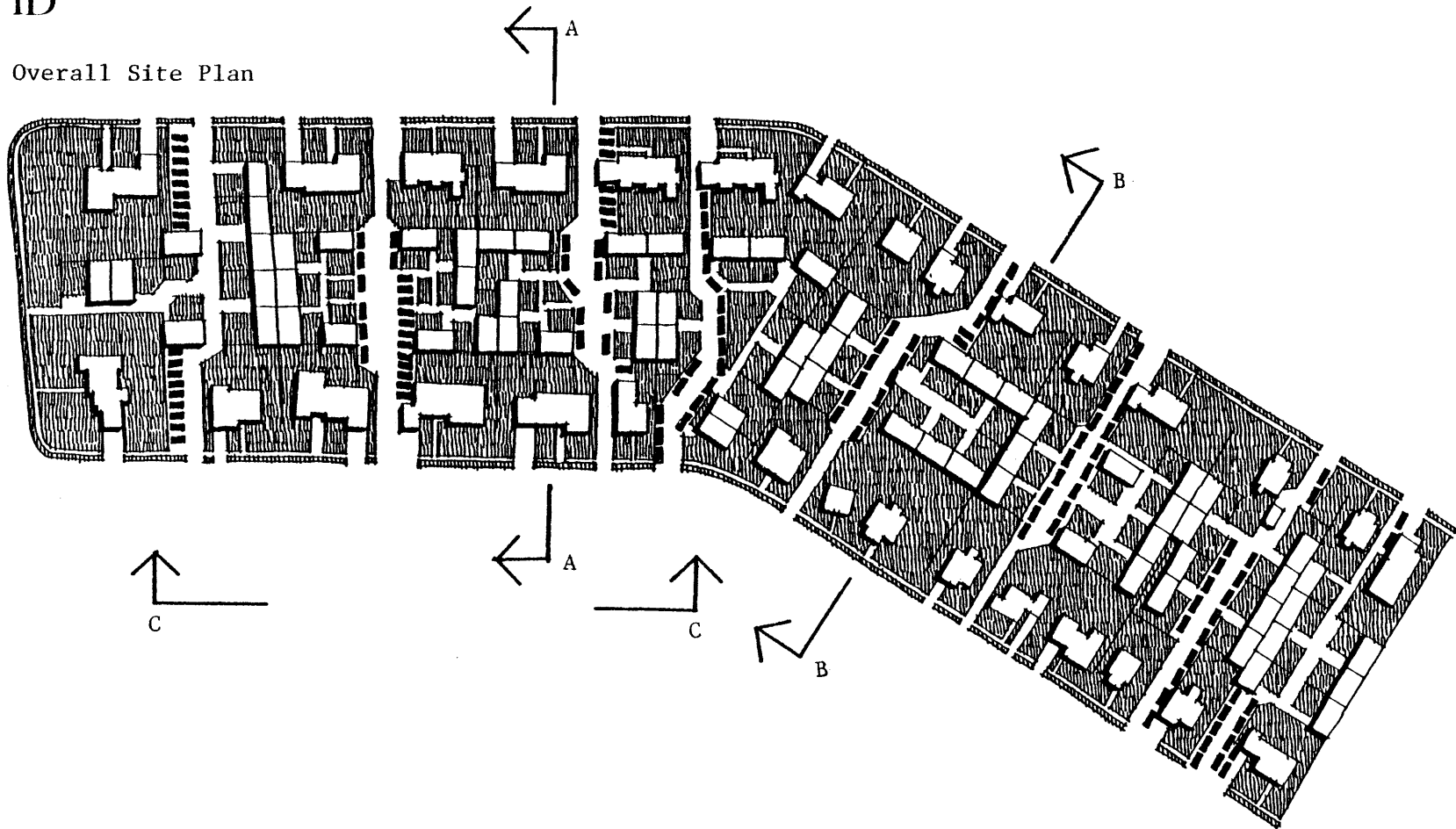

Section C-C



Land Aggregation Assumed

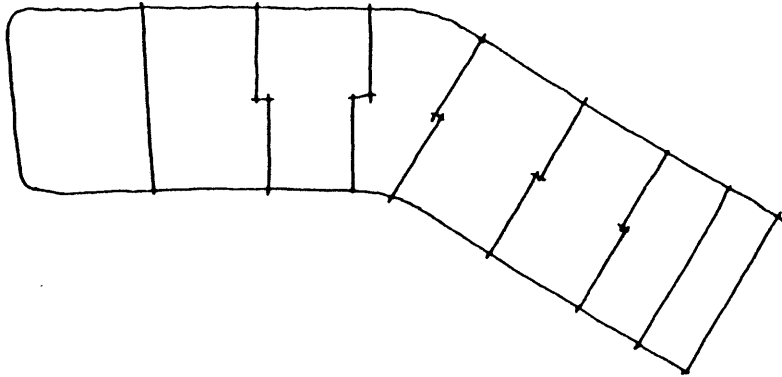

Public Circulation Patterns Generated

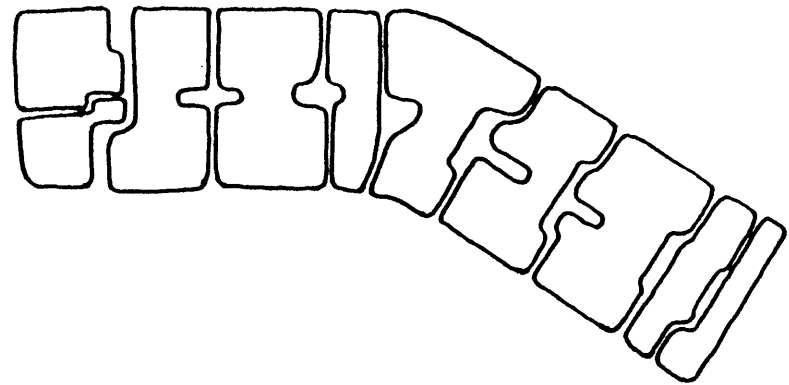

Settlement Pattern Generated

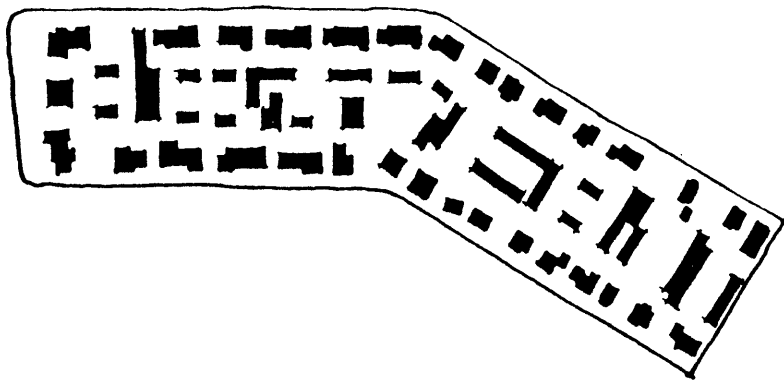

Parking Distribution Generated

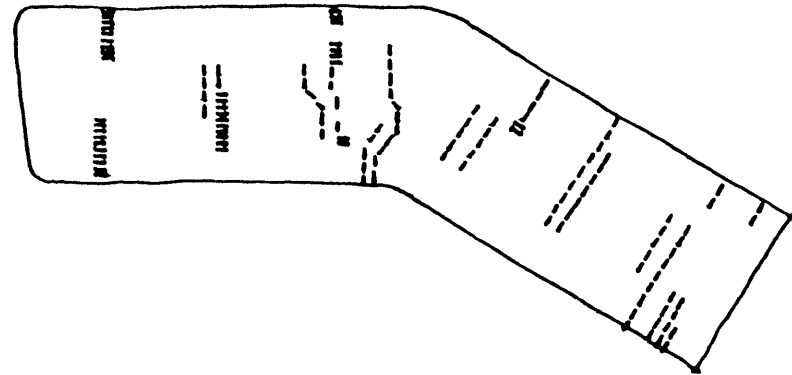

Section A-A



Section B-B



1E

Overall Site Plan

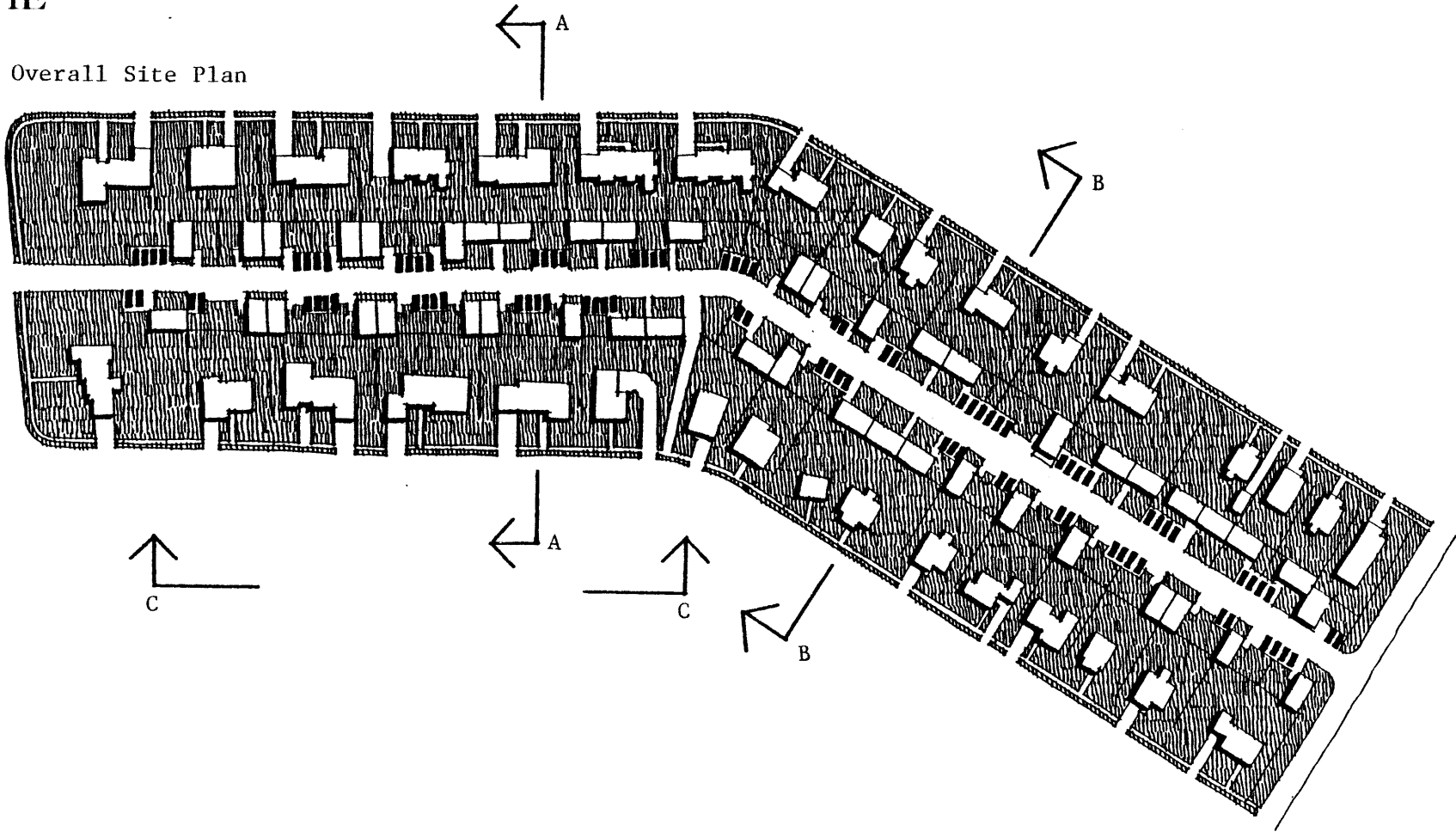

Section C-C



Land Aggregation Assumed

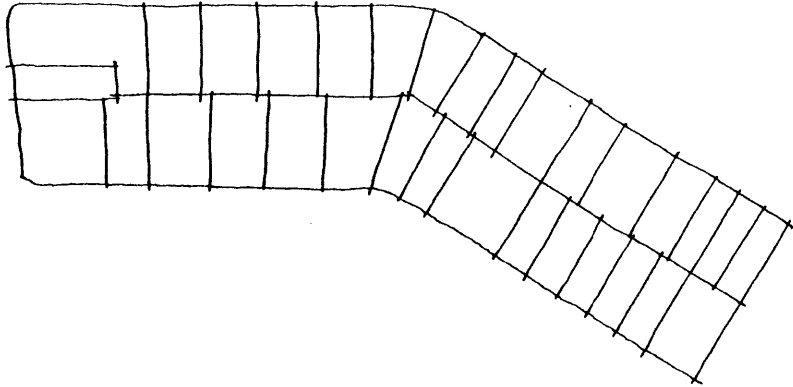

Public Circulation Patterns Generated

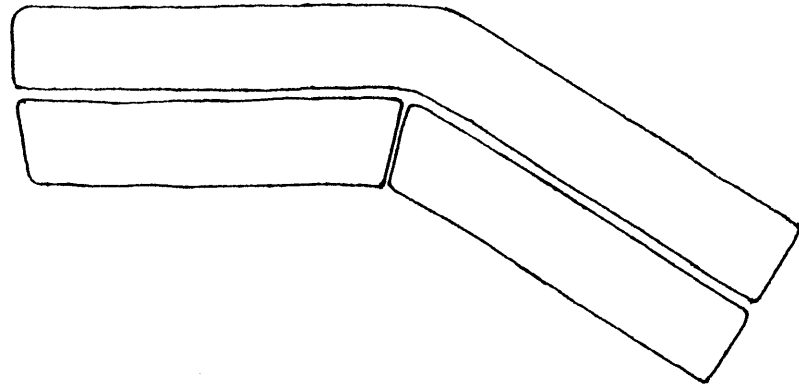

Settlement Pattern Generated

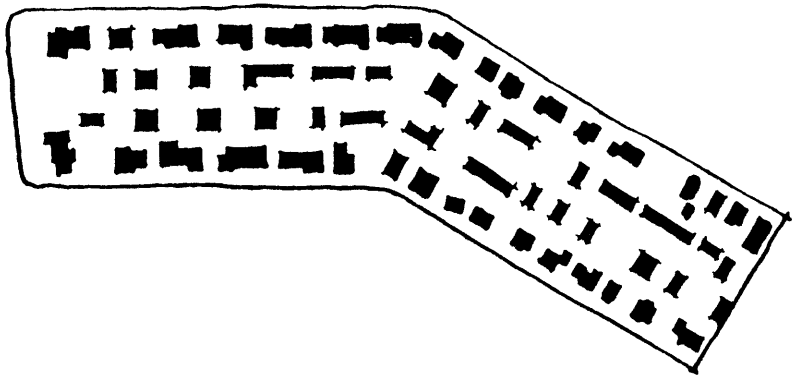

Parking Distribution Generated

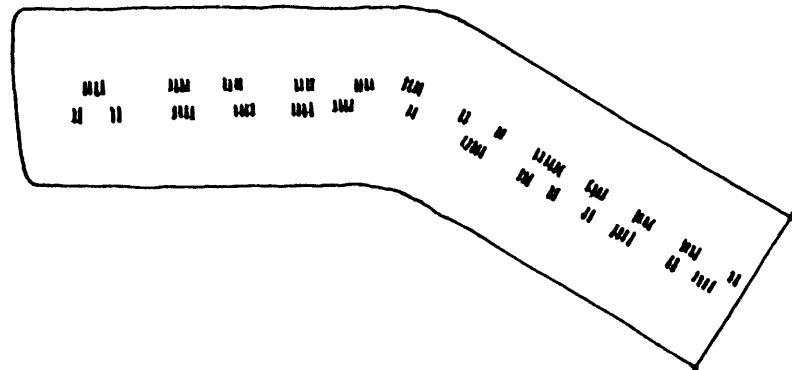

Section A-A



Section B-B



1F

Overall Site Plan

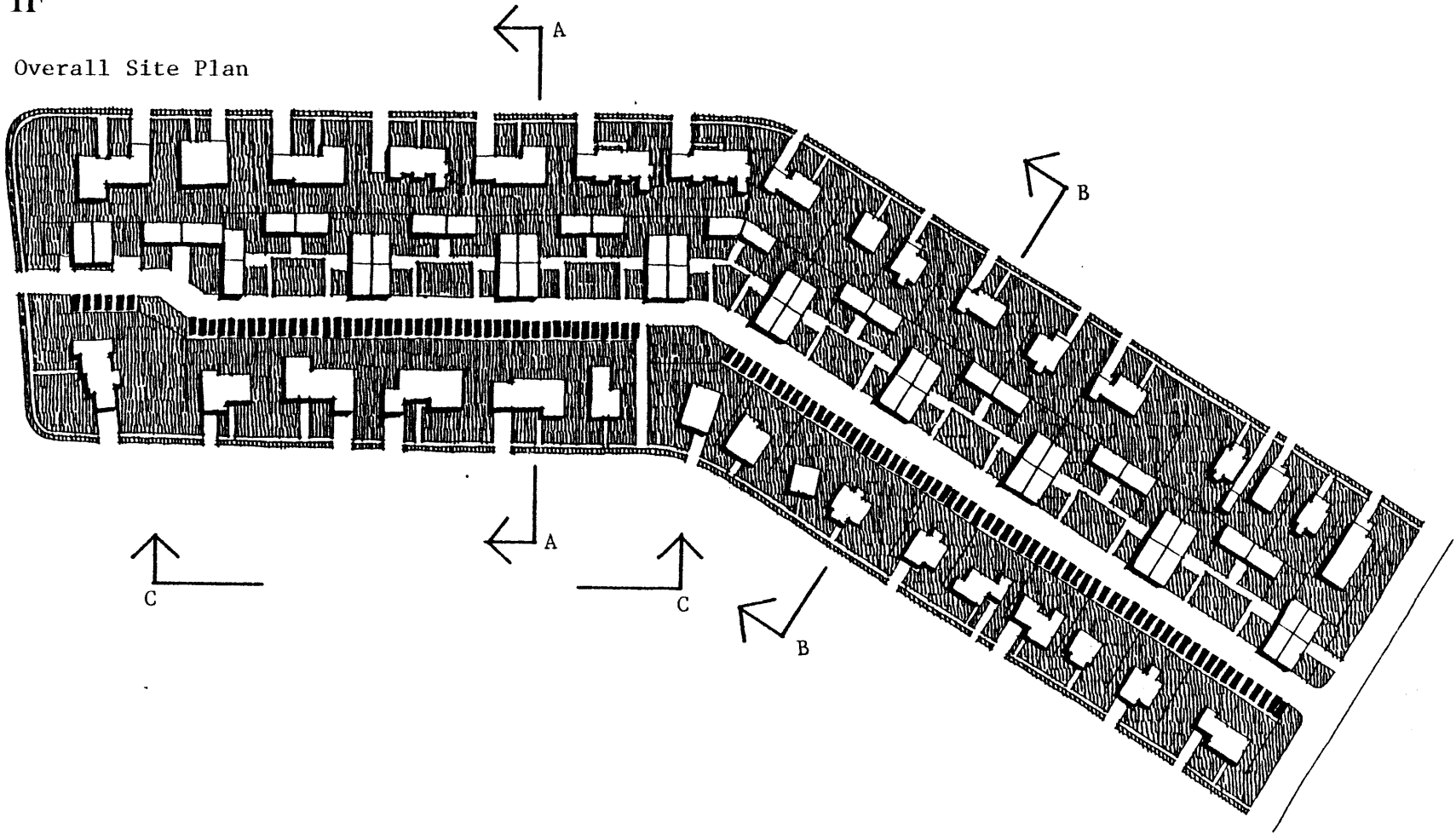

Section C-C



Land Aggregation Assumed

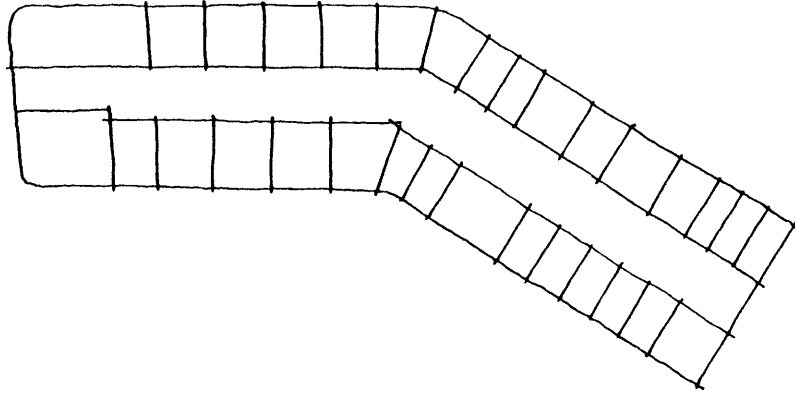

Public Circulation Patterns Generated

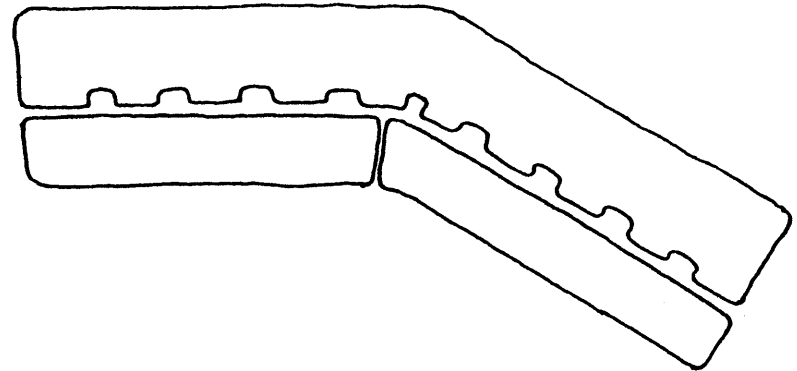

Settlement Pattern Generated

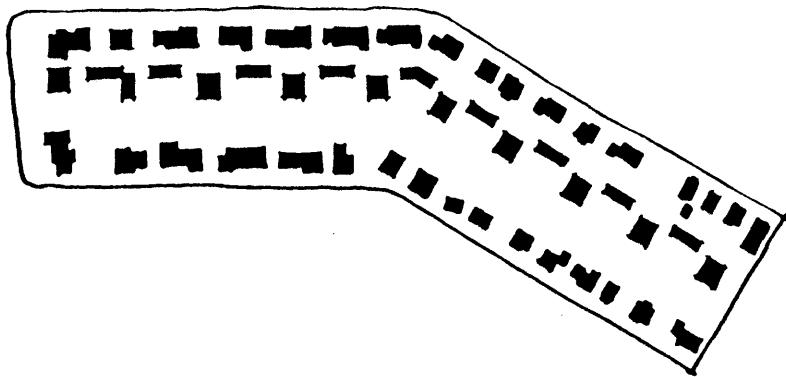

Parking Distribution Generated

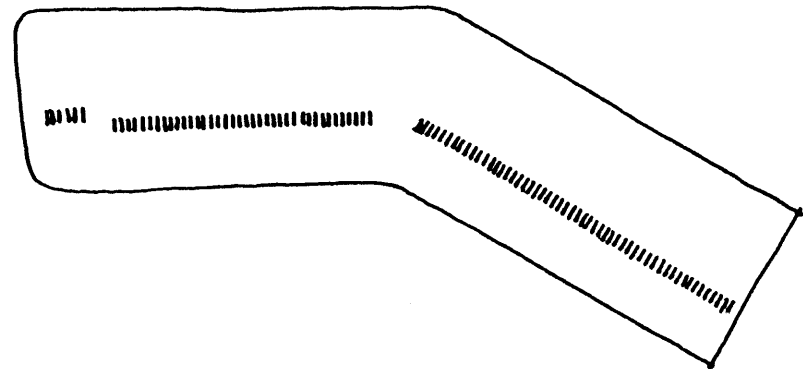

Section A-A

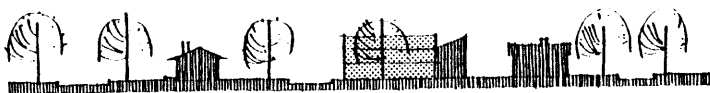

Section B-B



1G

Overall Site Plan

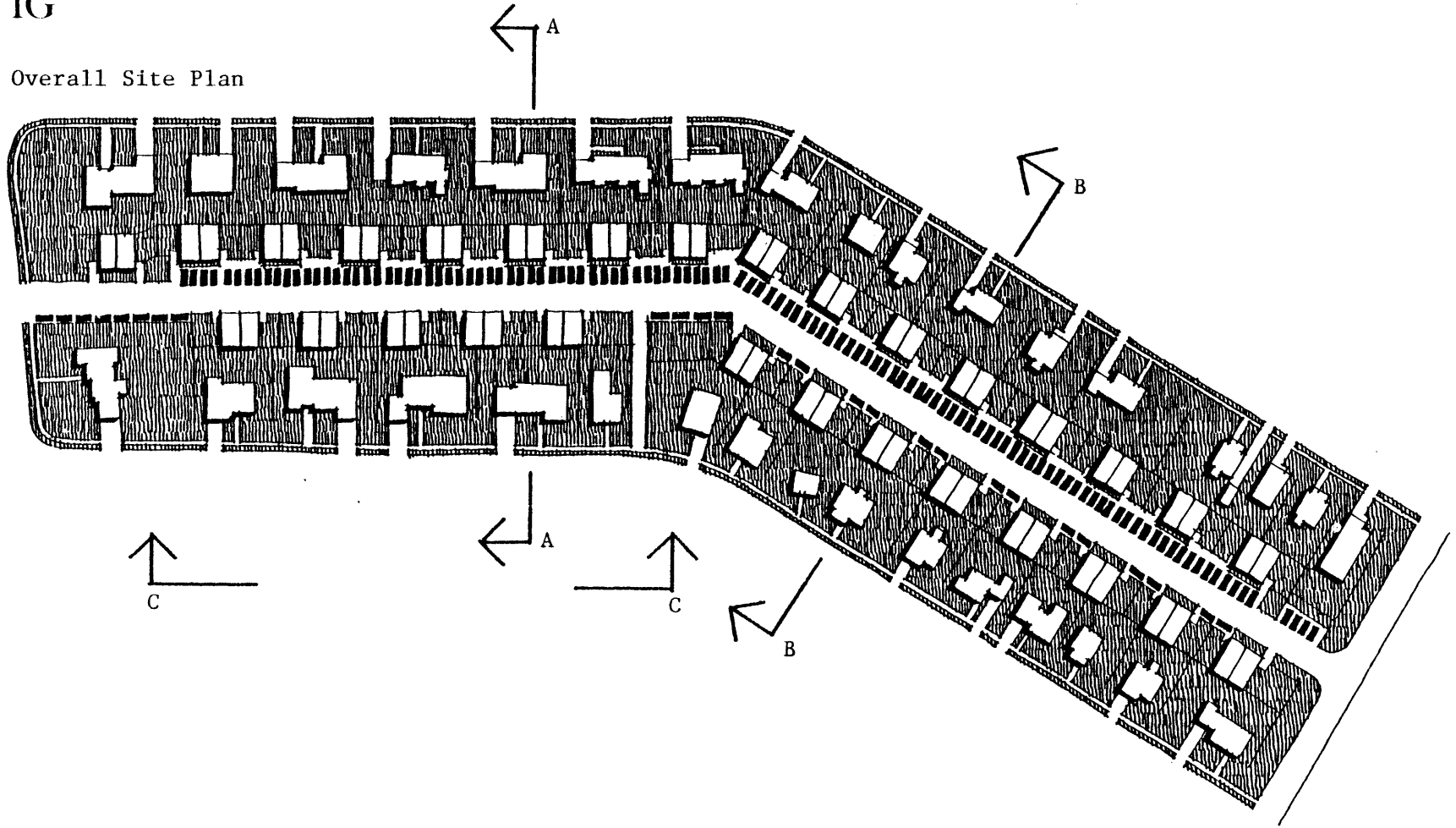

Section C-C



Land Aggregation Assumed

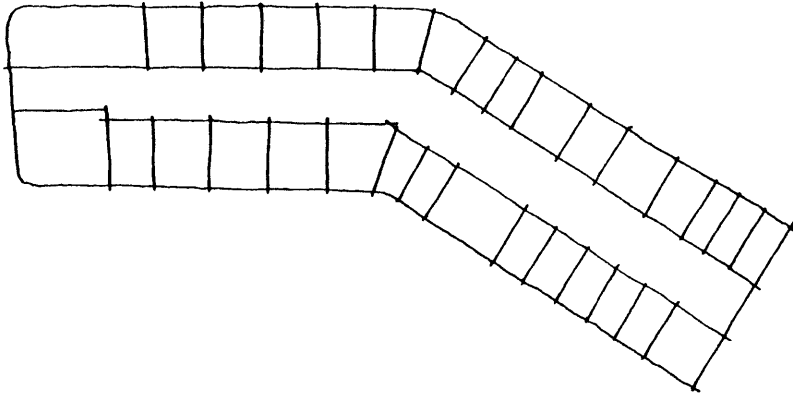

Public Circulation Patterns Generated

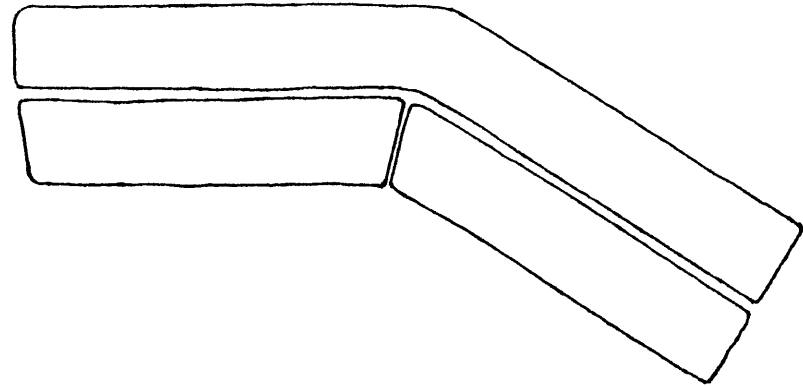

Settlement Pattern Generated

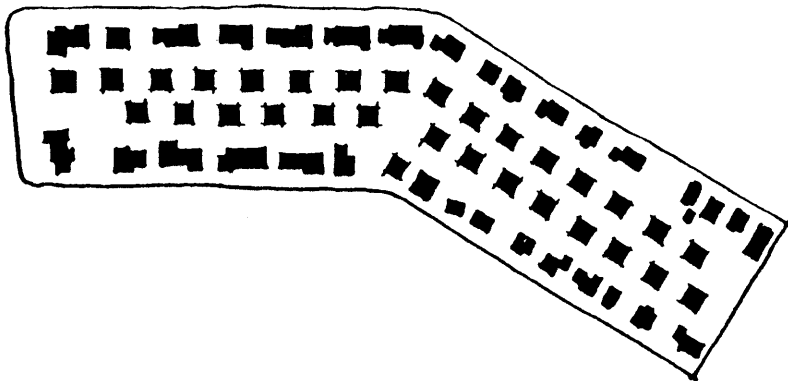

Parking Distribution Generated

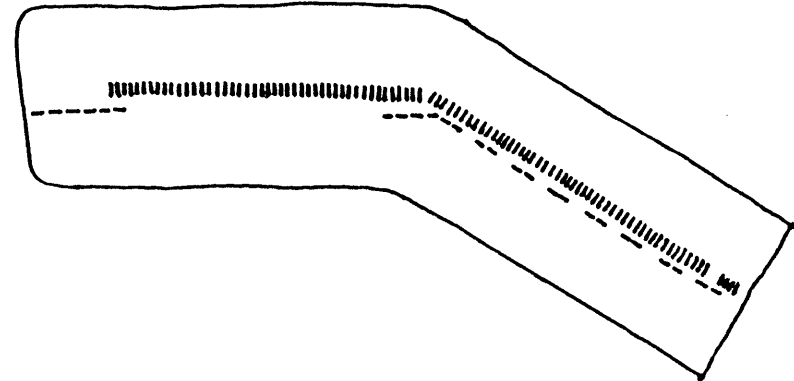

Section A-A



Section B-B



2A

Overall Site Plan

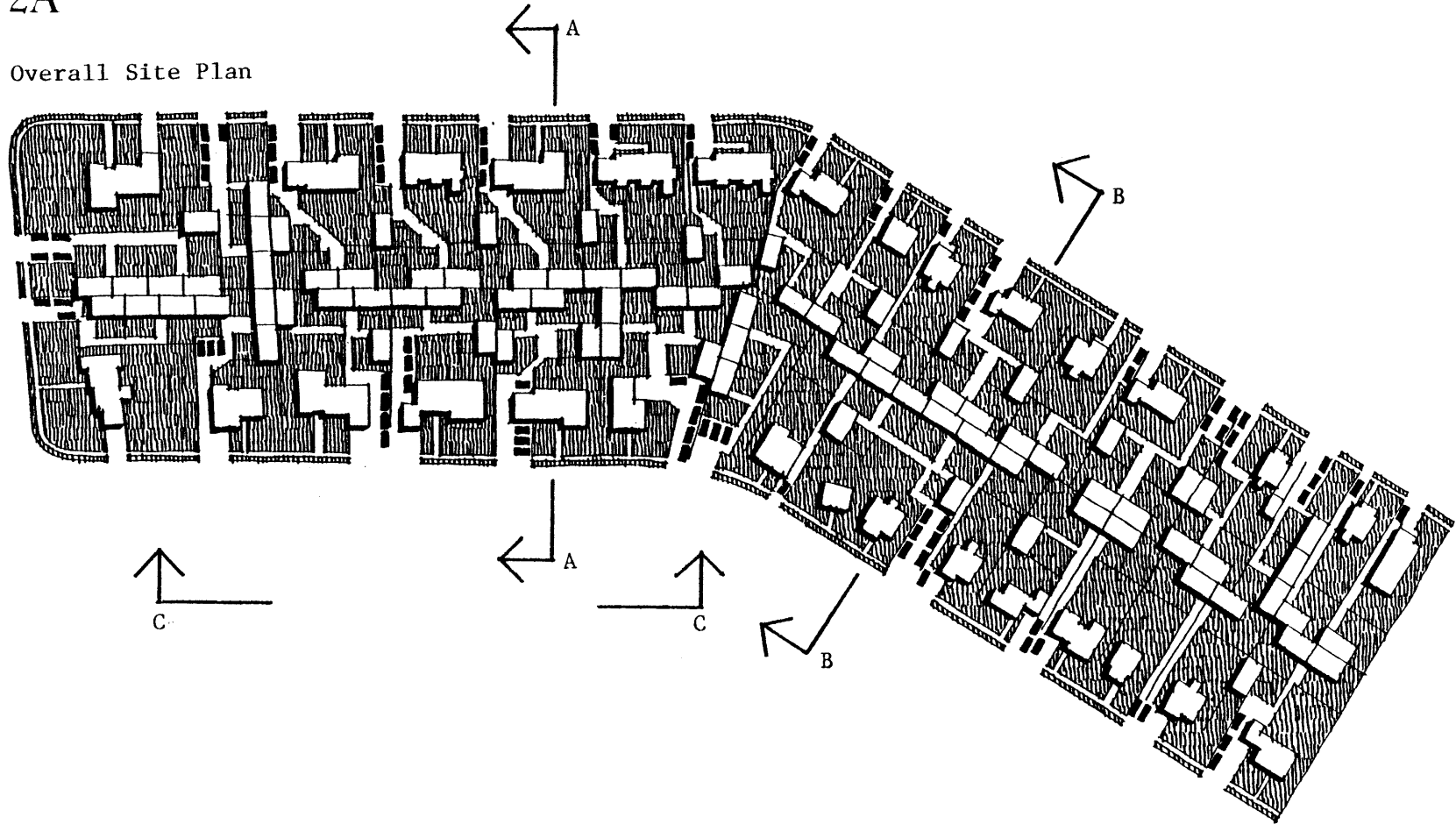

Section C-C



Land Aggregation Assumed

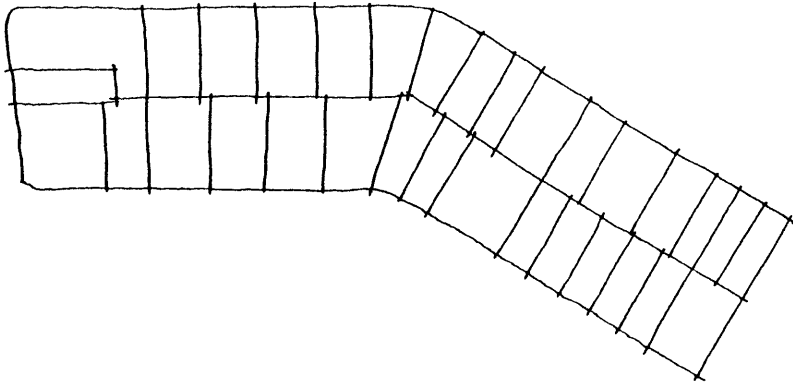

Public Circulation Patterns Generated

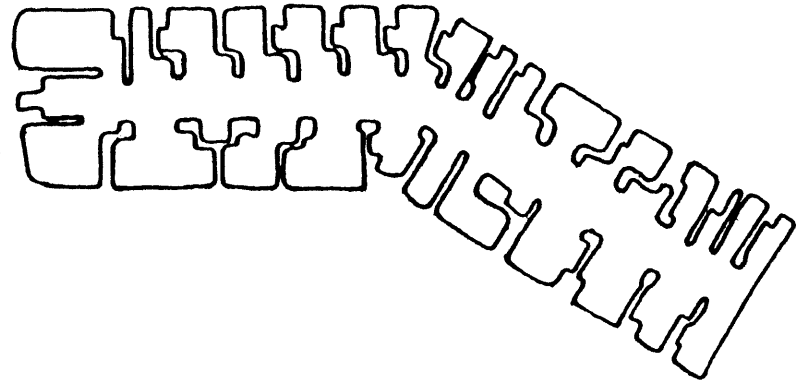

Settlement Pattern Generated

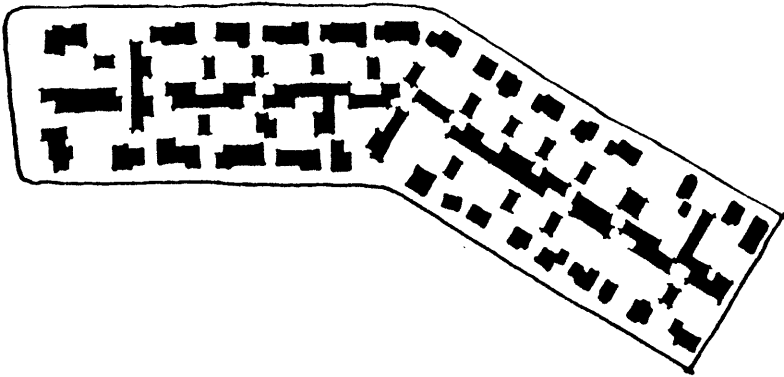

Parking Distribution Generated

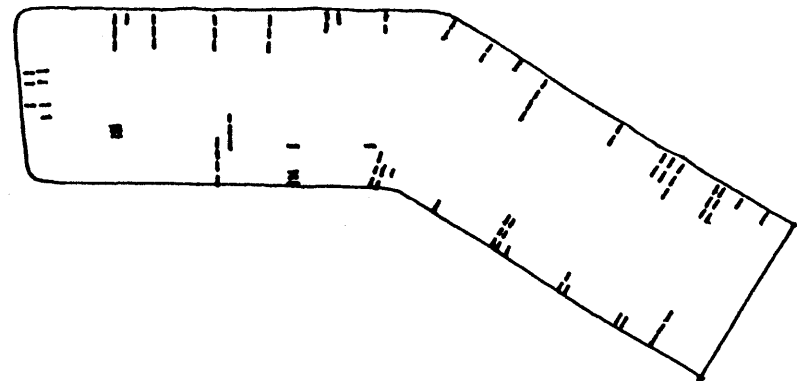

Section A-A



Section B-B



2B

Overall Site Plan

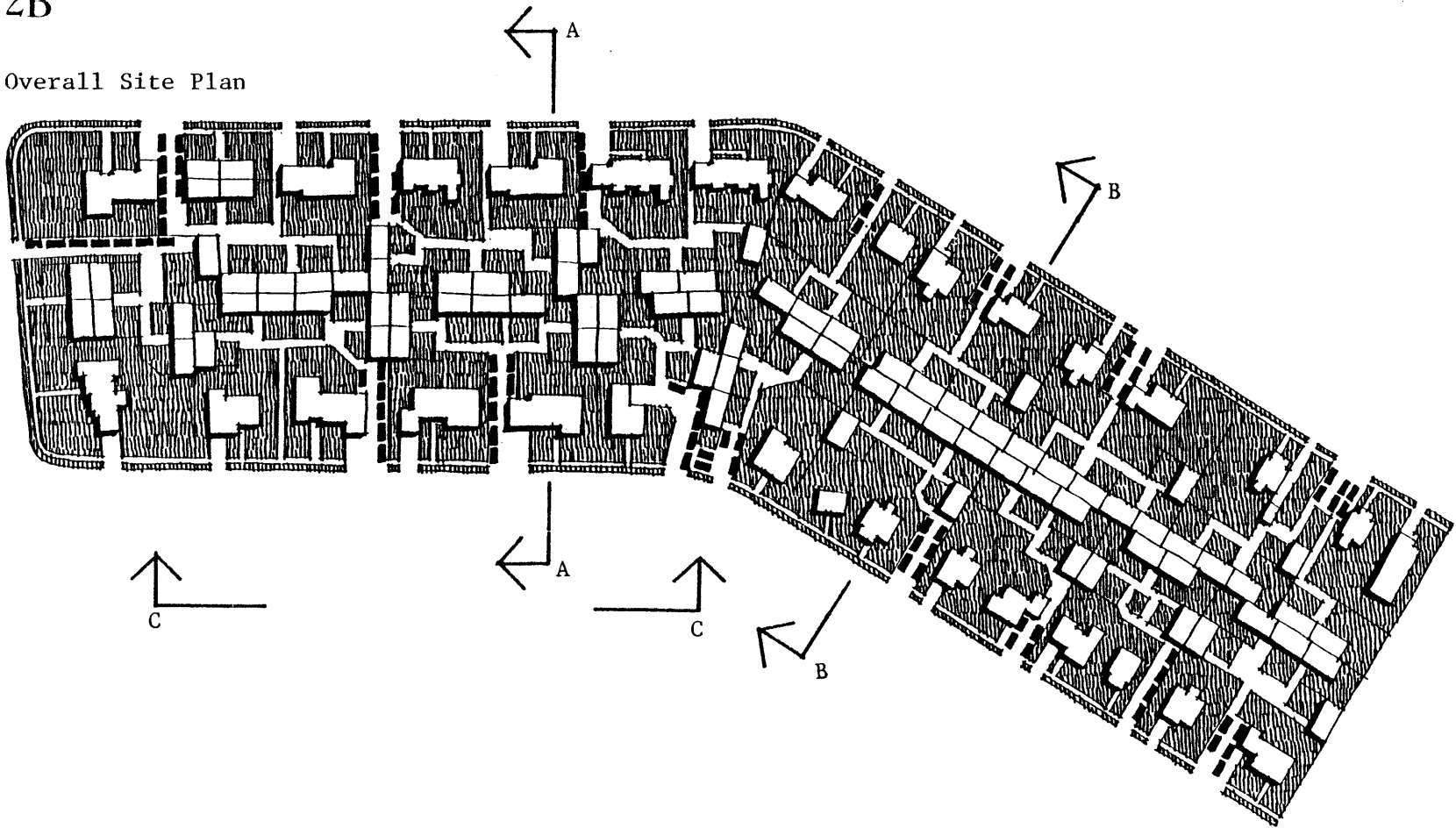

Section C-C



Land Aggregation Assumed

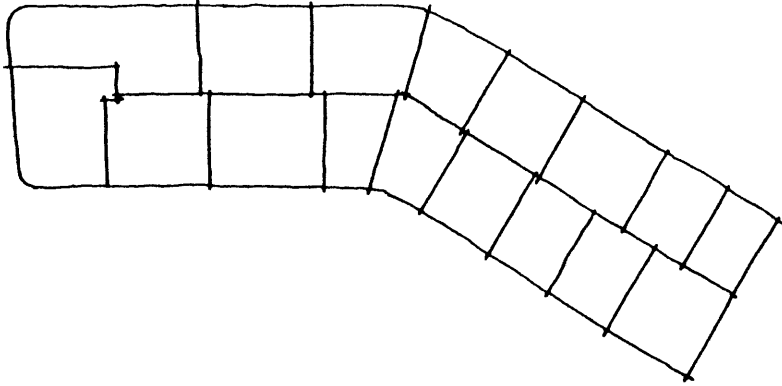

Public Circulation Patterns Generated

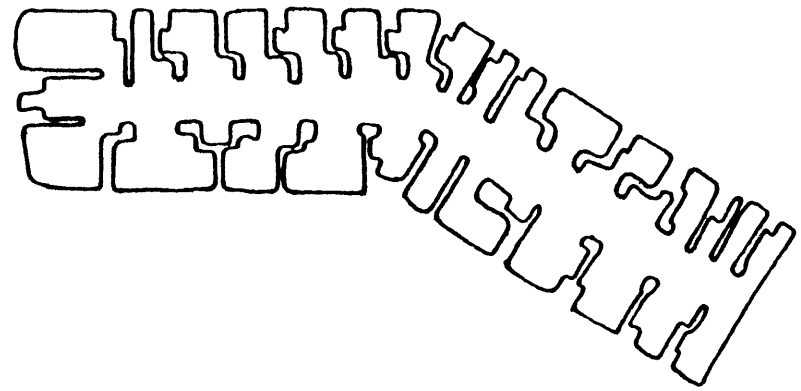

Settlement Pattern Generated

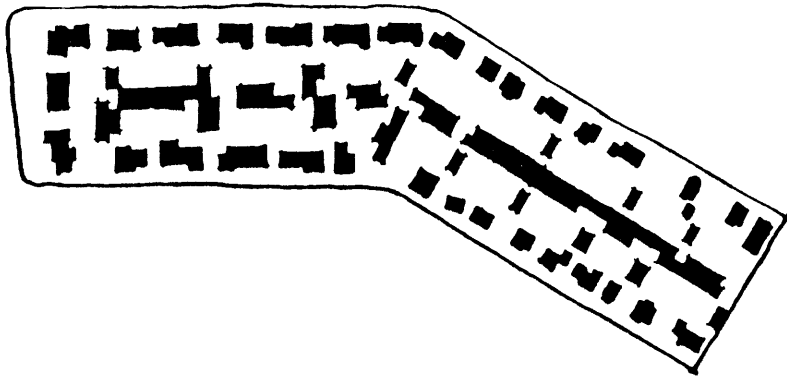

Parking Distribution Generated

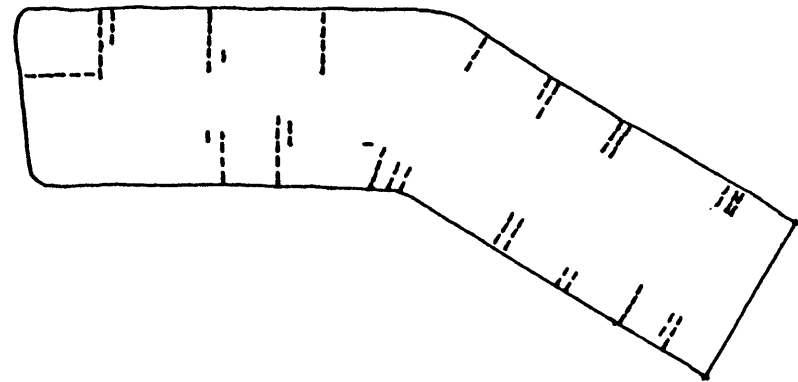

Section A-A



Section B-B



2C

Overall Site Plan

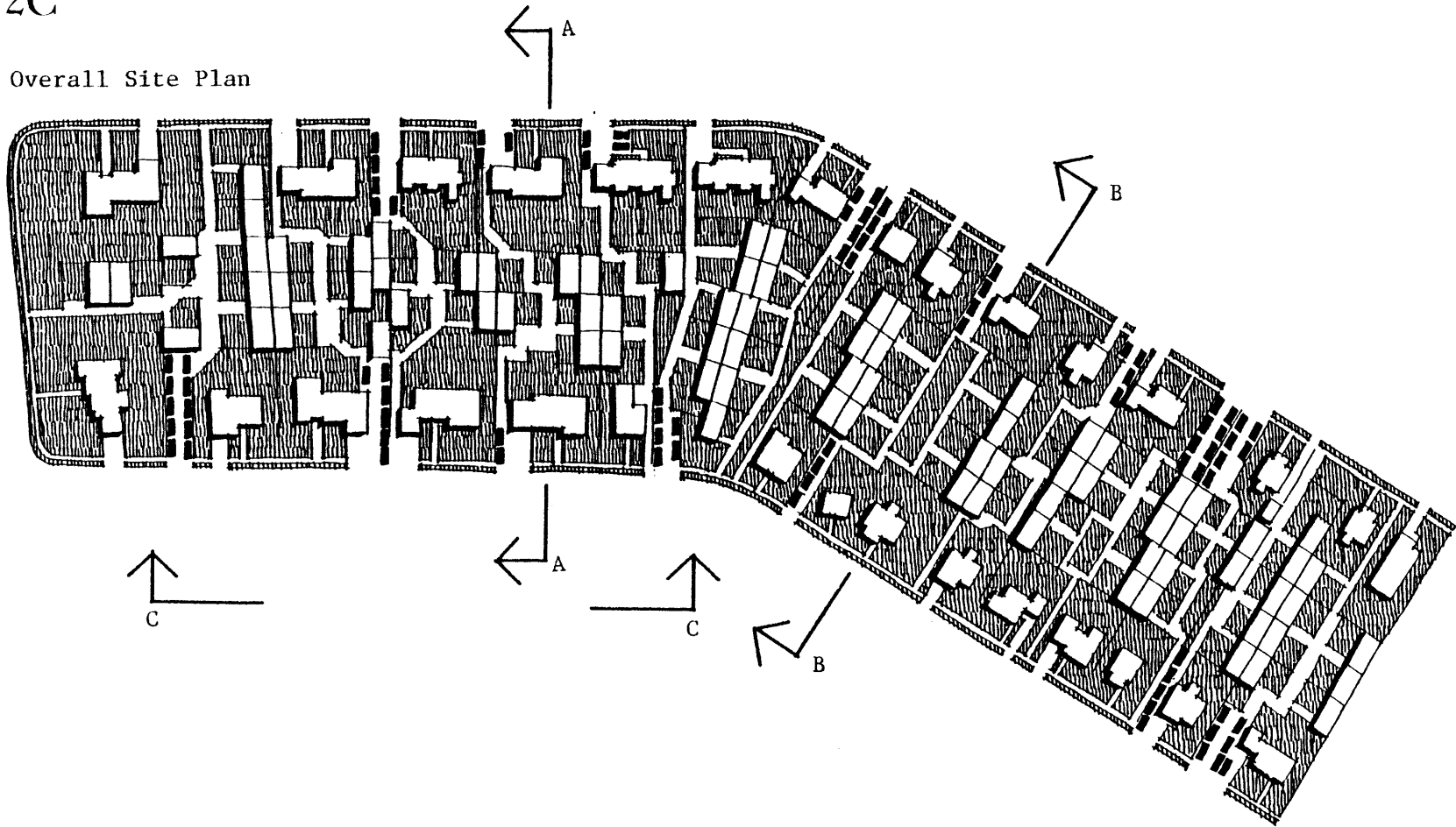

Section C-C



Land Aggregation Assumed

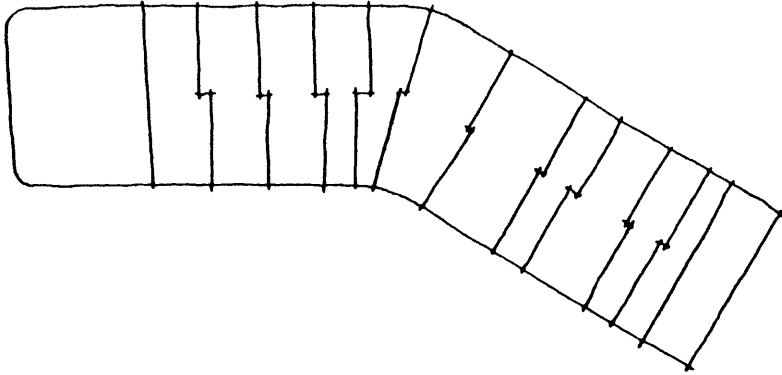

Public Circulation Patterns Generated

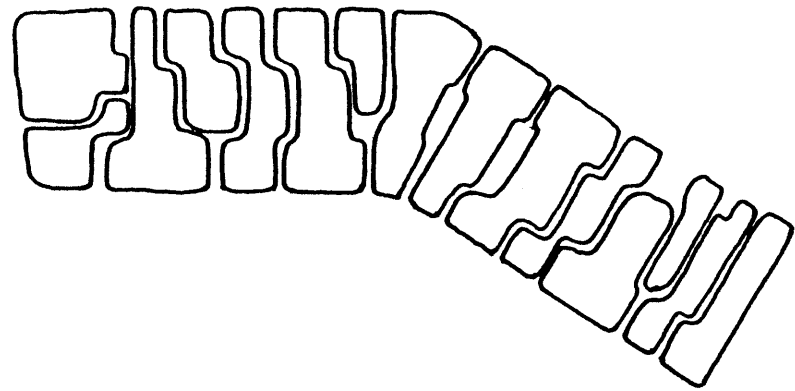

Settlement Pattern Generated

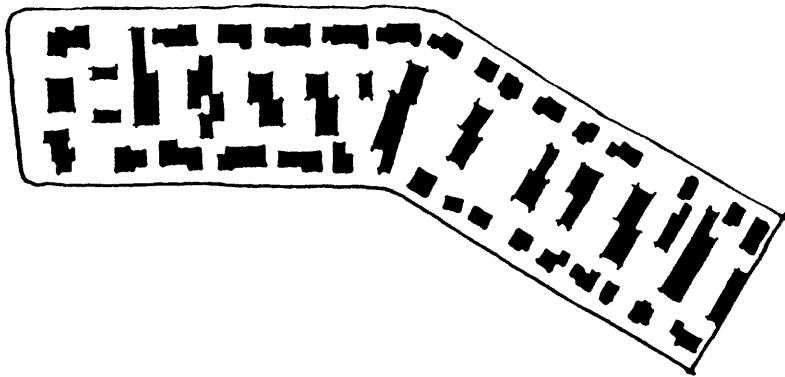

Parking Distribution Generated

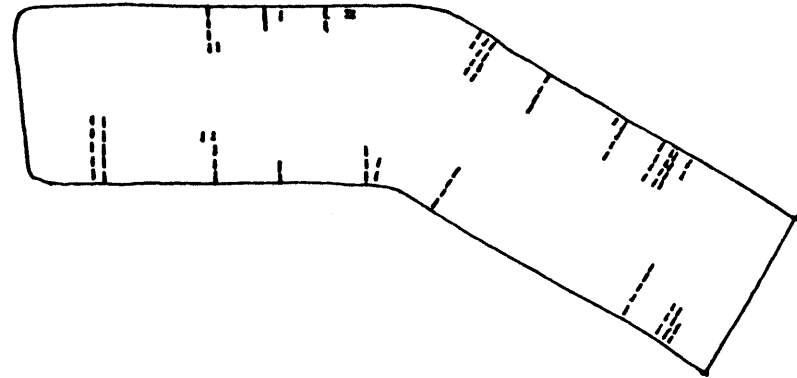

Section A-A

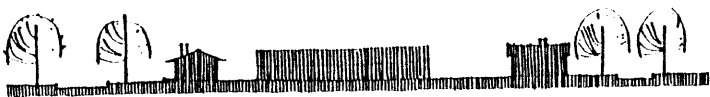

Section B-B

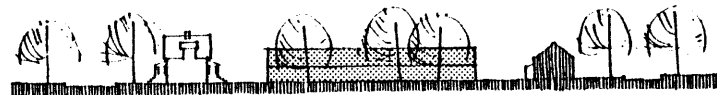

2D

Overall Site Plan

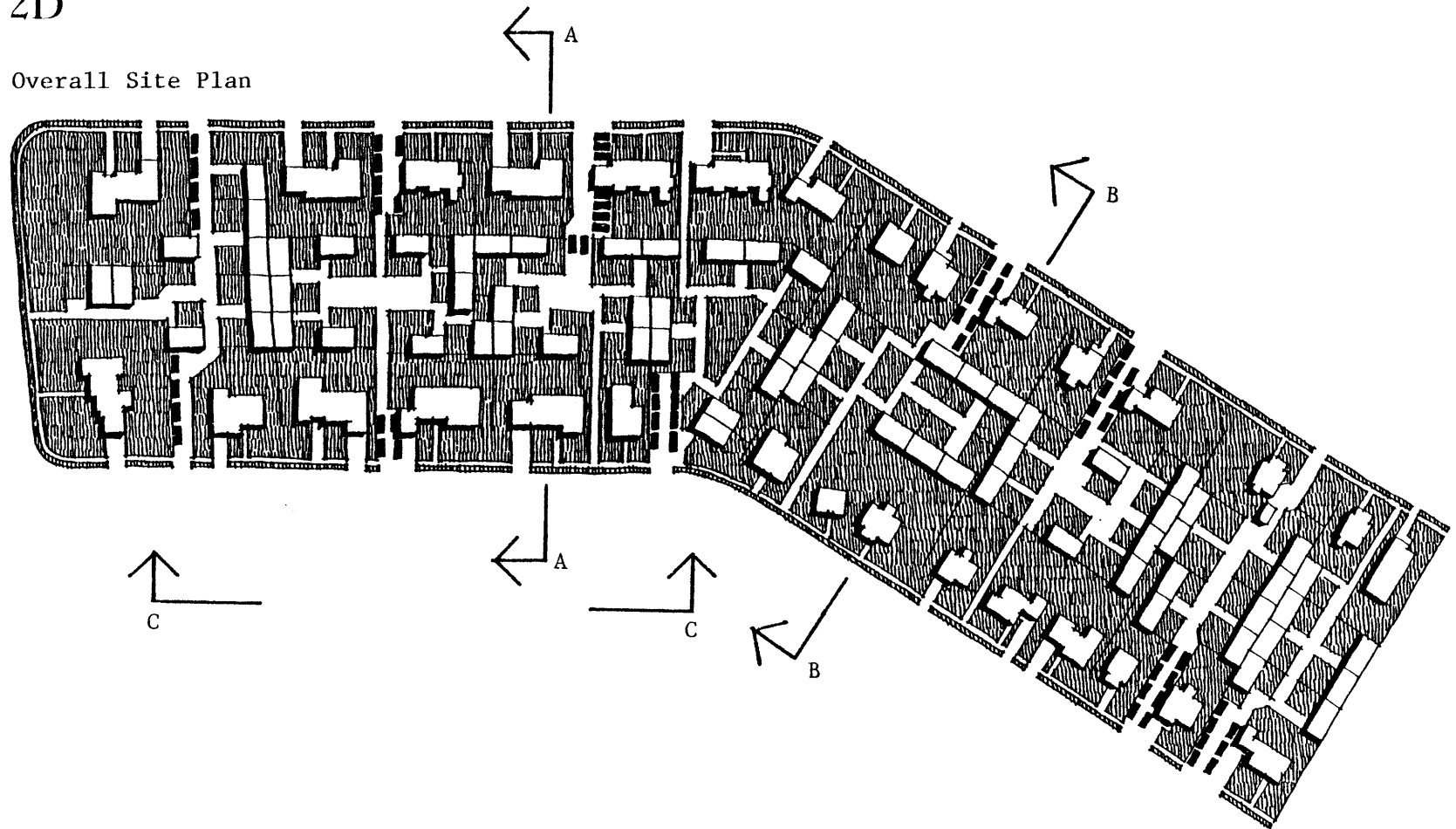

Section C-C



Land Aggregation Assumed

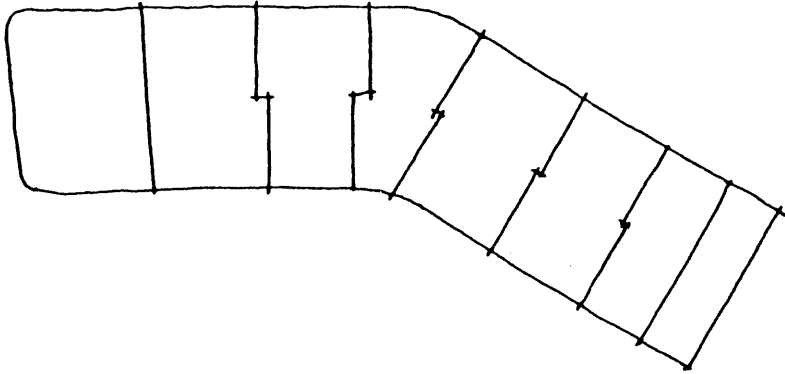

Public Circulation Patterns Generated

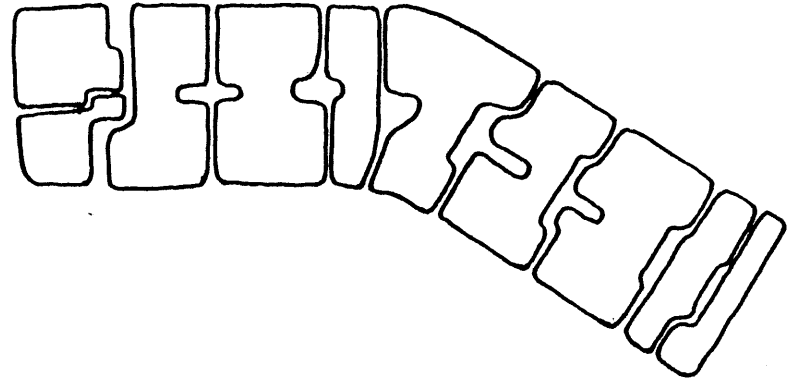

Settlement Pattern Generated

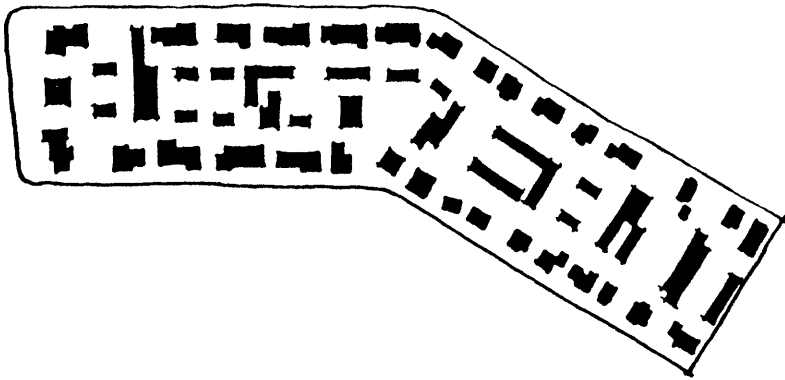

Parking Distribution Generated

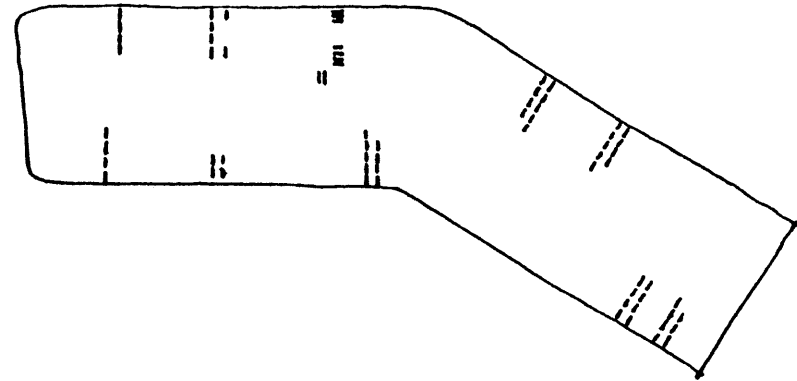

Section A-A

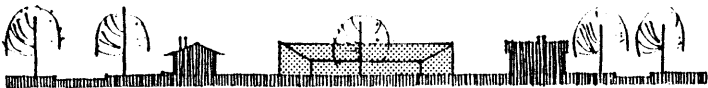

Section B-B

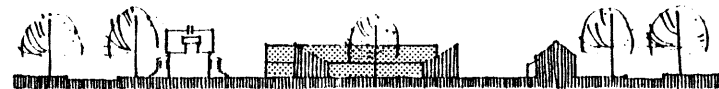

2E

Overall Site Plan

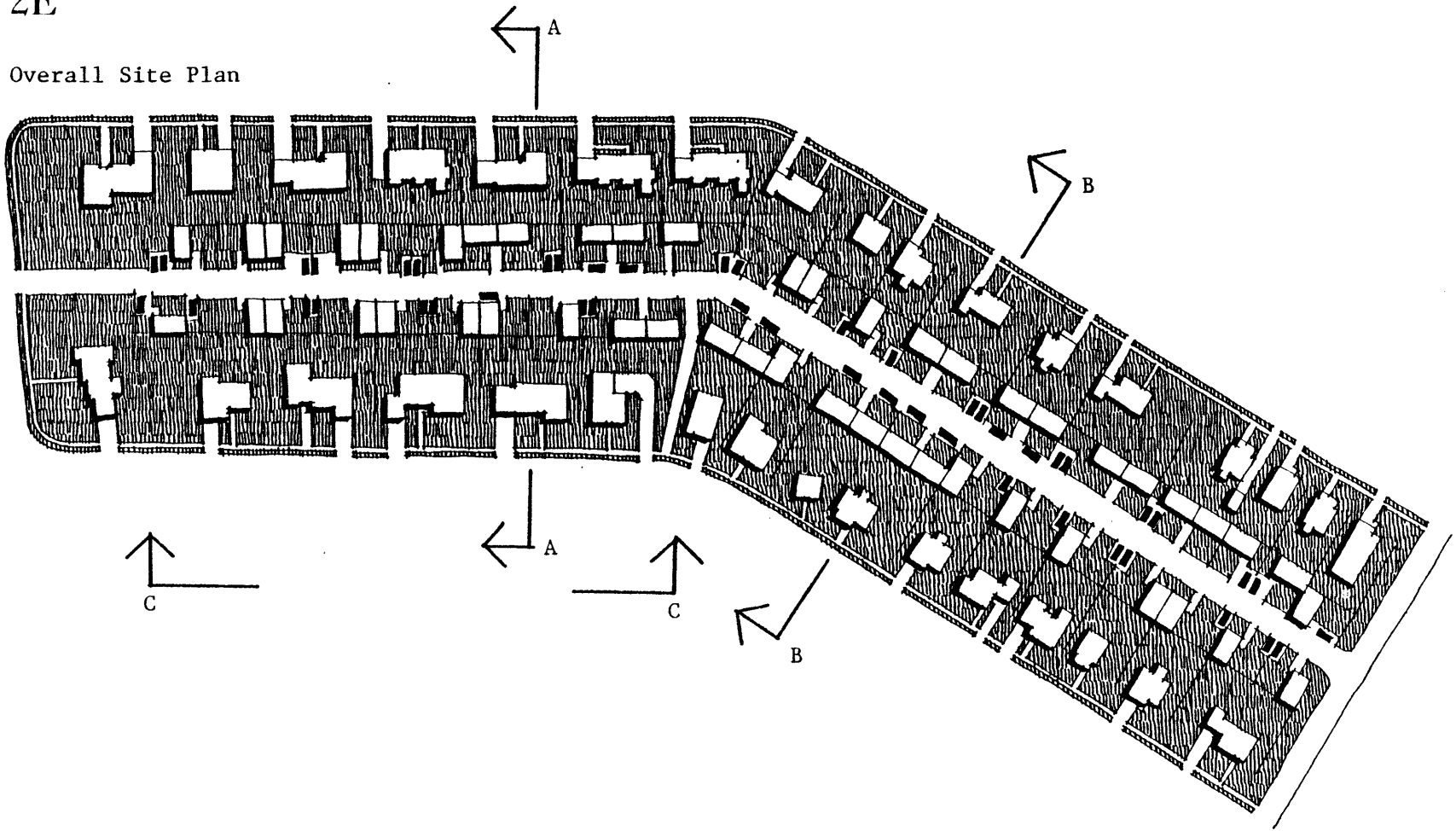

Section C-C



Land Aggregation Assumed

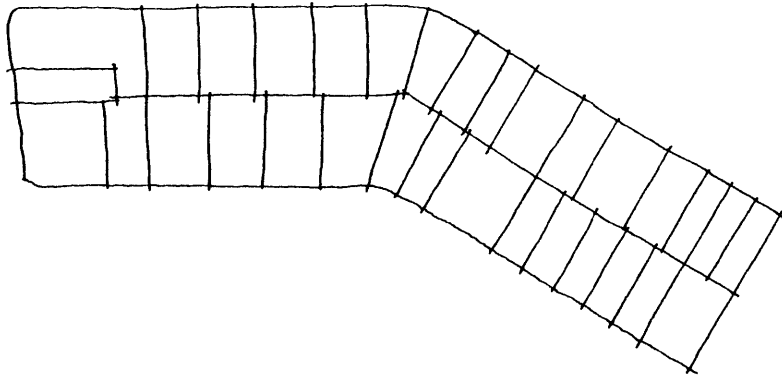

Public Circulation Patterns Generated

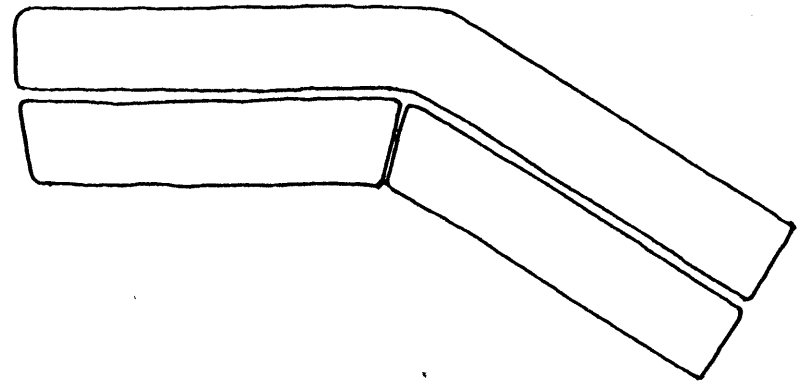

Settlement Pattern Generated

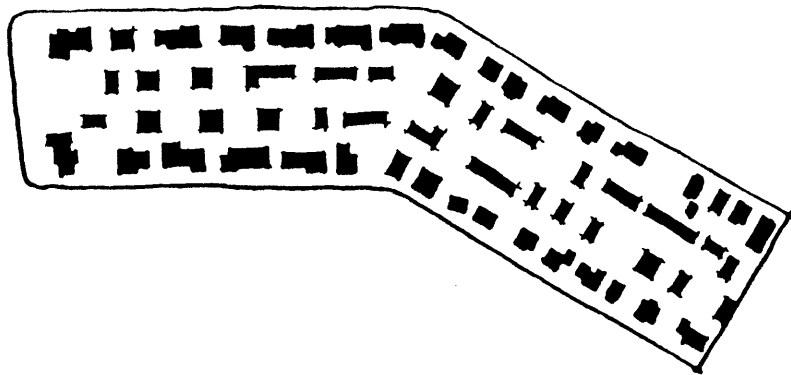

Parking Distribution Generated

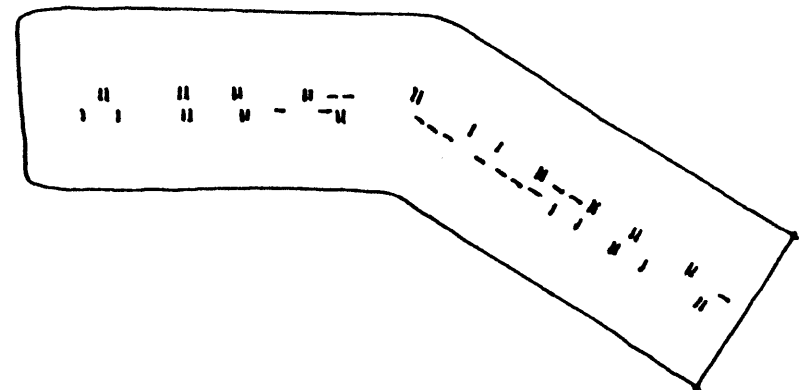

Section A-A



Section B-B



2F

Overall Site Plan

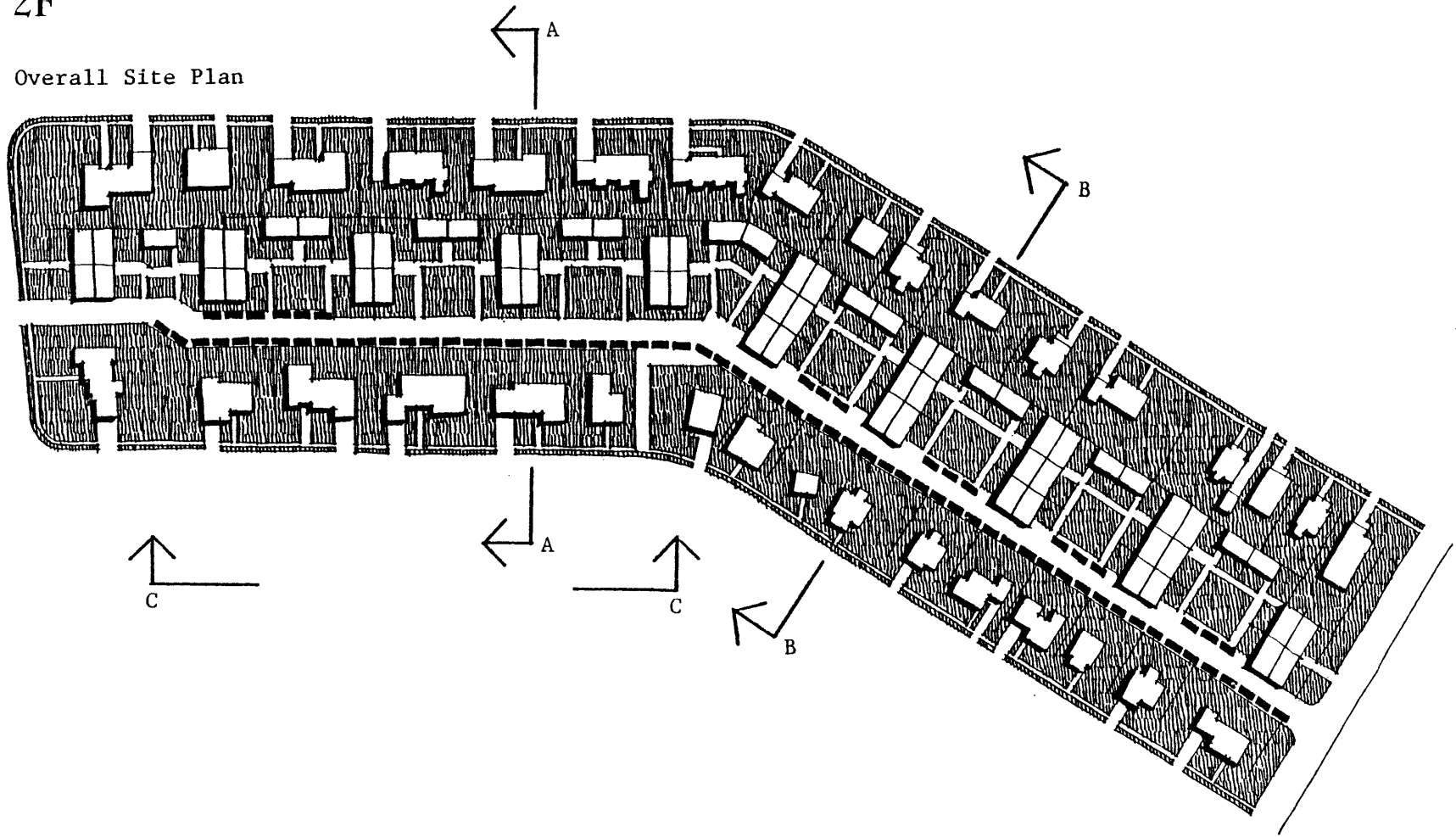

Section C-C



Land Aggregation Assumed

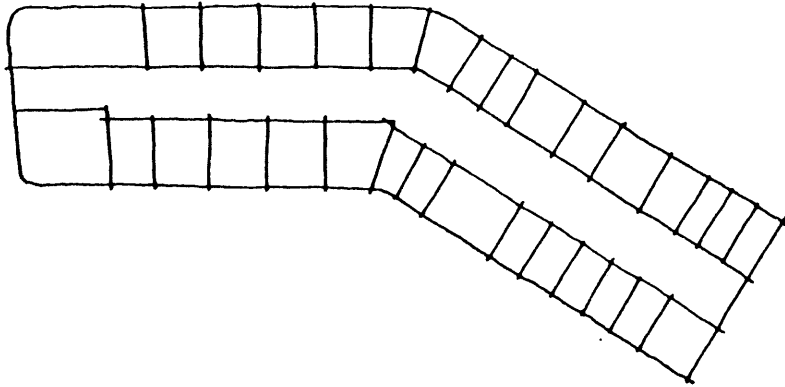

Public Circulation Patterns Generated

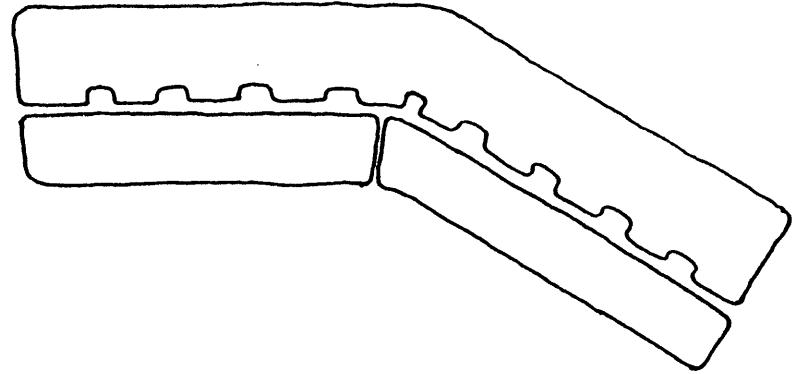

Settlement Pattern Generated

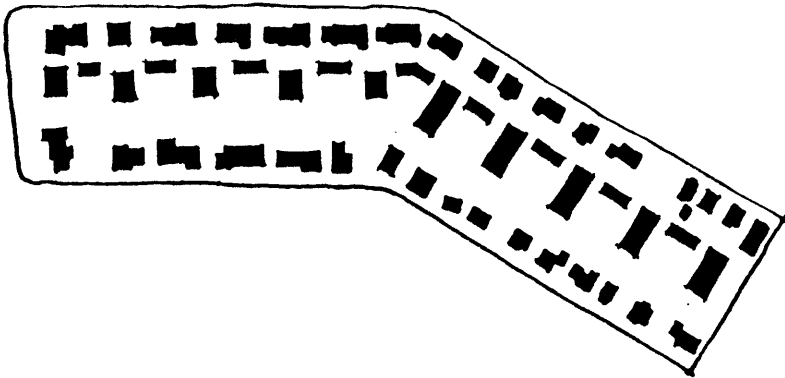

Parking Distribution Generated

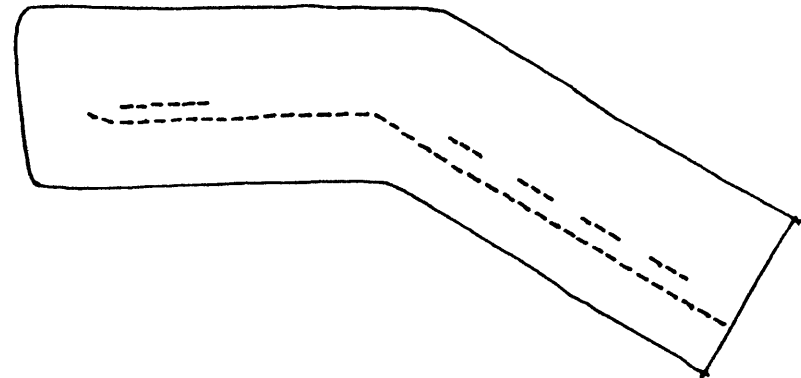

Section A-A

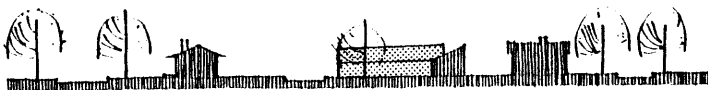

Section B-B



2G

Overall Site Plan

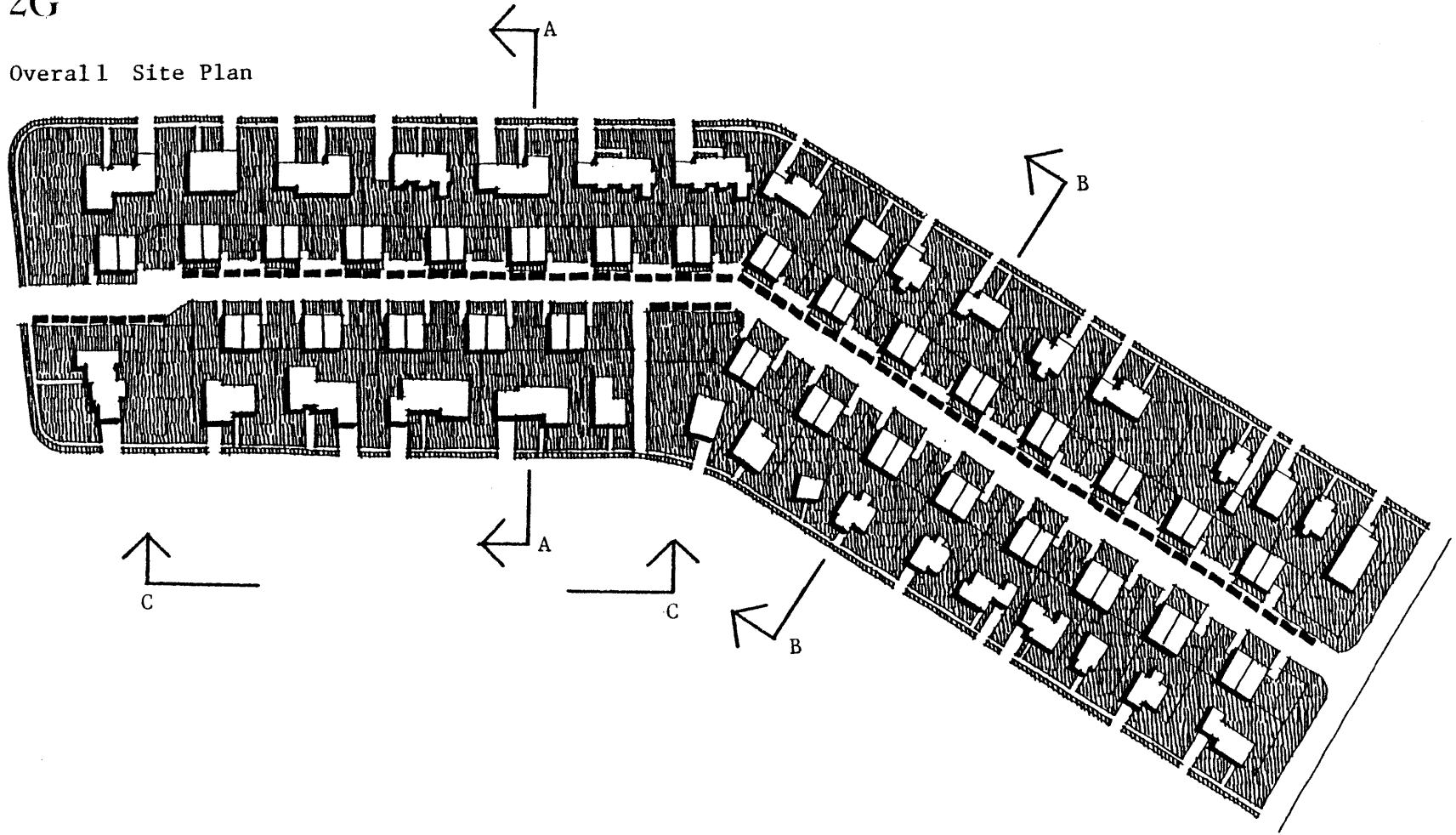

Section C-C



Land Aggregation Assumed

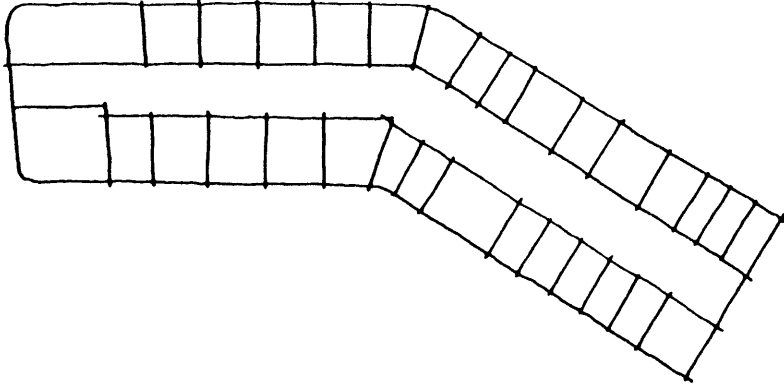

Public Circulation Patterns Generated

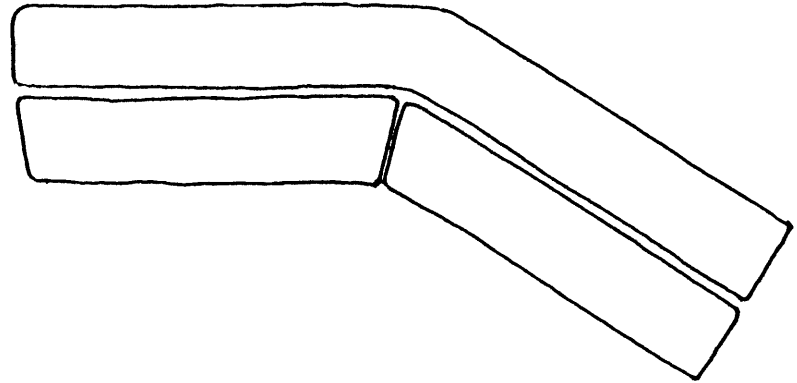

Settlement Pattern Generated

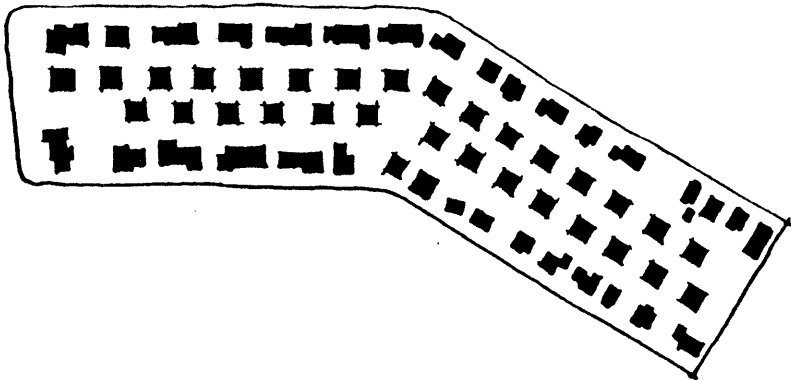

Parking Distribution Generated

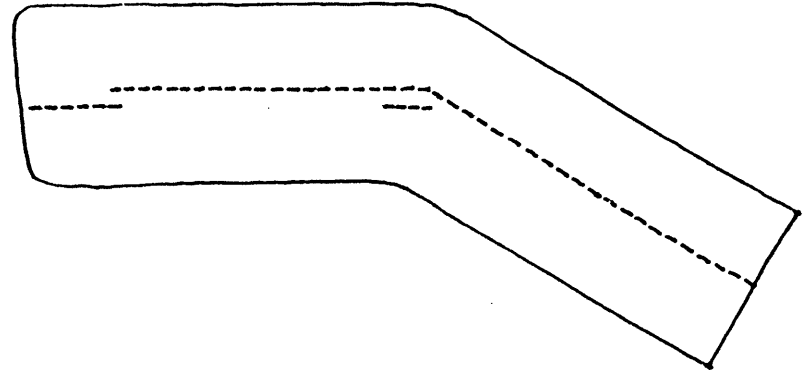

Section A-A



Section B-B



3A

Overall Site Plan

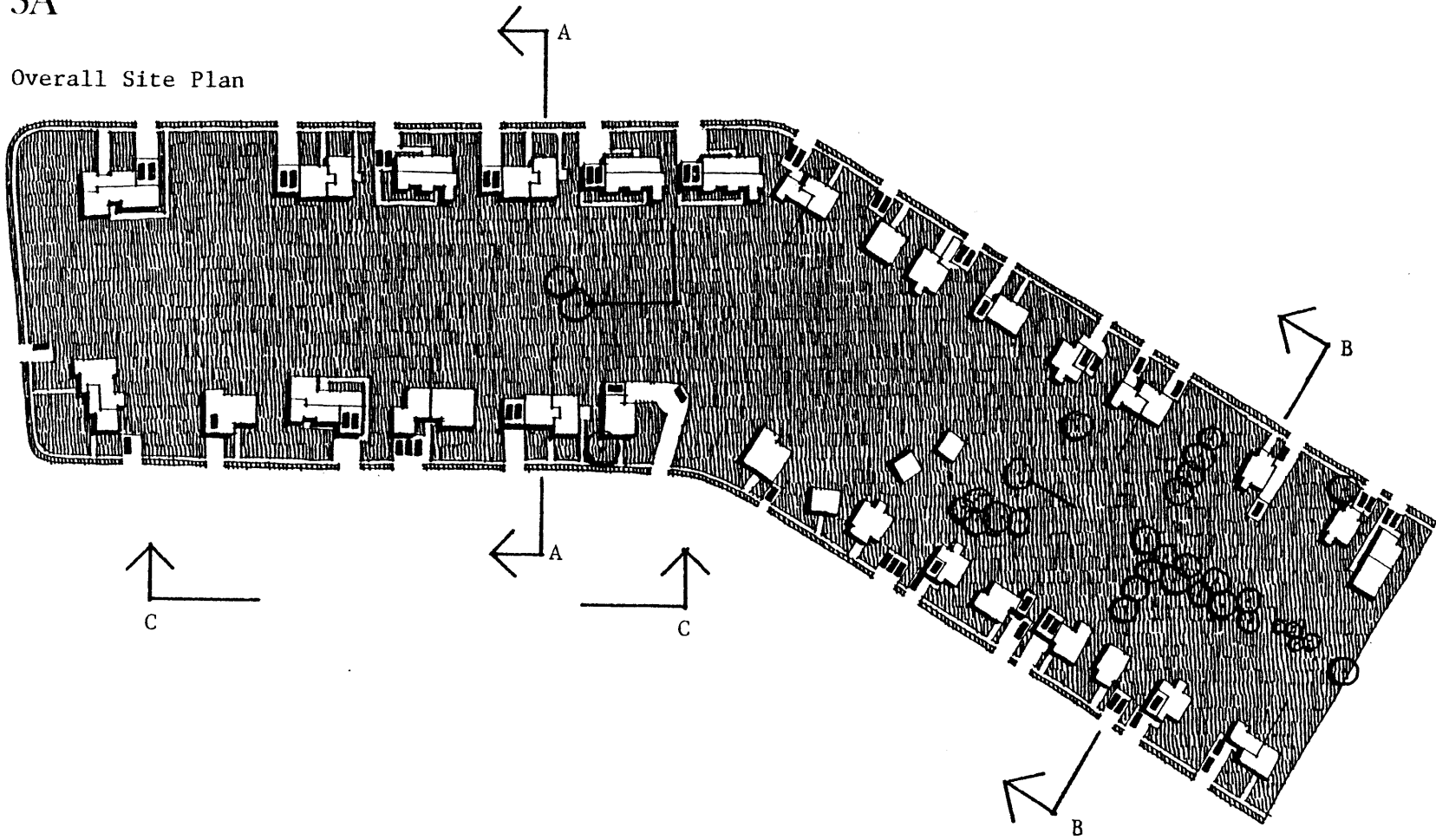

Section C-C



Land Aggregation Assumed

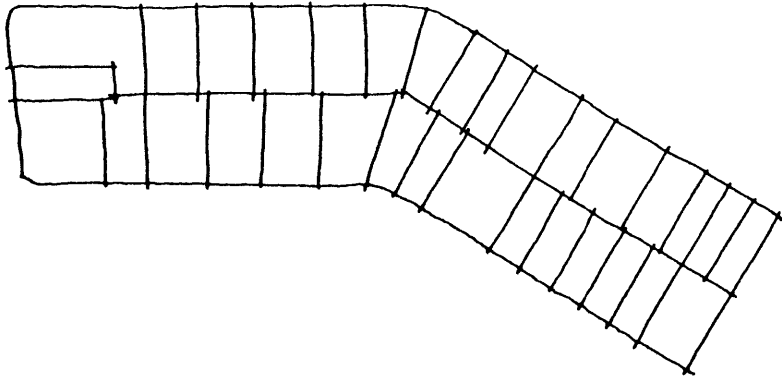

Public Circulation Patterns Generated

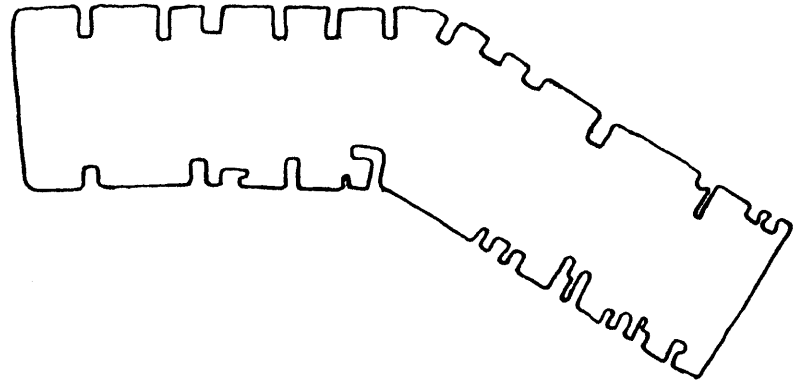

Settlement Pattern Generated

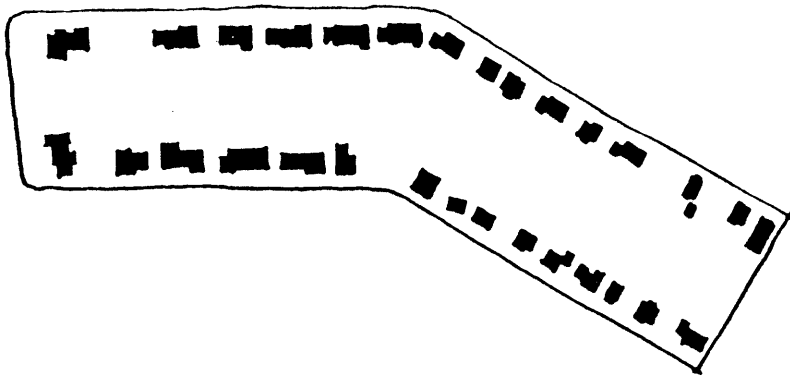

Parking Distribution Generated

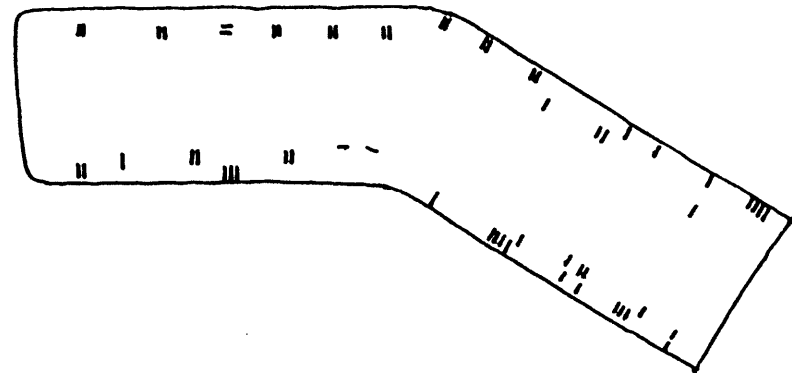

Section A-A



Section B-B



III. EVALUATIONS

Quantitative Analysis

Explanation of the data summarized in the table that follows.

Column 1

The maximum number of dwelling units that could be projected onto the working site in each Design Exploration. Each 700 sq. ft. of new living space was counted as one dwelling unit. Existing homes were counted as one dwelling unit each, except for scheme 3 - subdivision.

Column 2

The number of dwelling units that are directly linked to outdoor living space in the form of yards and gradens.

Column 3

The number of dwelling units without direct connection to yards and gardens.

Column 4

The percentages of the working site covered with buildings. New and existing structures are included in these numbers.

Column 5

The percentages of the working site devoted to paving. Includes all new and existing driveways, and parking lots. Also includes the new street in schemes 1E, F, G & 2E, F, G.

Column 6

Totals of columns 4 & 5.

Column 7

Lineal feet (LF) of new sewer and utility lines (gas, electric, water) required to service the new dwelling units. Does not include any extension of the public infrastructure, only connections to it. Measurements were taken from the centerline of the existing streets to the building footprints, in each case. The minimum number of connections to the existing infrastructure was assumed. (See diagram.)

Column 8

Lineal feet (LF) of new sewer and utility lines (gas, electric, water) required to service the new dwelling units, in the form of an extension of the existing public infrastructure. (See diagram.)

Column 9

The amount of sewer and utility work required to serve each new dwelling unit. The figures in column 8 have been weighted to reflect the

assumed cost difference per (LF) of these figures over those in column 7 (LF in column 7 + 2 x LF in column 8)/new dwelling units.

Column 10

The square footages (SF) of new paving required for on-site parking. Includes driveways and parking lots only.

Column 11

The square footages (SF) of new paving required for new streets.

Column 12

The amount of new paving required to accommodate each additional car on site. The figures in column 11 have been weighted to reflect the assumed cost difference per (SF) of these figures over those in column 10. (SF in column 10 + 2 x SF in column 11)/cars accommodated.

QUANTITATIVE ANALYSIS

Design Exploration	1. dwelling unit count, total	2. dwelling unit count, number on grade	3. dwelling unit count, number above grade	4. site coverage (%) dwelling unit footprints	5. site coverage (%) paving	6. site coverage (%) total columns 4&5	7. sewers & utilities (LF), minor lines	8. sewers & utilities (LF), major lines	9. sewers & utilities (LF/ unit), total columns 7&8	10. auto paving (SF), minor work	11. auto paving (SF), major work	12. auto paving (SF/ unit), total columns 10&11
EX	30	30	0	11.2	4.5	15.7	--	--	--	--	--	--
1A	178	104	74	23.1	23.5	46.6	6400	0	43	50400	0	340
B	192	111	81	24.3	27.0	51.3	4700	0	29	48300	0	298
C	194	112	82	24.4	30.9	55.3	4500	0	27	66000	0	402
D	170	100	70	22.5	26.7	49.2	3800	0	27	57200	0	409
E	125	79	46	20.0	18.3	38.3	1400	1200	41	17600	36000	974
F	141	87	54	21.1	21.6	42.7	1100	1200	32	20800	36000	859
G	149	91	58	21.7	22.5	44.2	1000	1200	29	46400	36000	1021
2A	116	116	0	25.0	19.7	44.7	6400	0	75	32200	0	374
B	117	117	0	29.2	20.5	45.7	4700	0	54	26400	0	303
C	112	112	0	24.4	23.4	47.8	4500	0	54	33000	0	402
D	100	100	0	22.5	20.8	43.3	3800	0	54	24000	0	343
E	82	82	0	20.3	17.9	38.2	1400	1200	77	10000	36000	1673
F	98	98	0	22.9	20.7	43.6	1100	1200	54	15200	36000	1343
G	91	91	0	21.8	18.5	40.3	1000	1200	59	13200	36000	1469
3A	56	44	12	11.2	7.3	18.5	-	-	-	8400	0	323

Qualitative Analysis

A list of six issues relating to the intrinsic "suburban" qualities of the block are raised for discussion in this analysis.

1. Massing of new construction
2. Daylighting & ventilation of new dwelling units
3. Private outdoor space
4. Visual privacy
5. Parking & car storage
6. Perception of openspace--views through the block

The results of the fifteen Design Explorations were compared to the unconsolidated block using site plans, site sections and site diagrams. From this overall review, consolidation patterns, which are unharmonious with this suburban setting, were pinpointed. Breakpoints between acceptable and unacceptable growth patterns were then established so that a more specific evalua-

tion could be carried out. The results of the analysis are summarized in chart form.

"Problem" areas

1. Massing of new construction:
 - Continuous strings of unit modules formed building masses that were uncharacteristic of the existing housing forms.
 - Two-story construction seemed "uncomfortably" close to the existing dwelling units when the 30 foot minimum building setback was used. This is simply my gut reaction to the site sections generated in these instances.

2. Daylighting & natural ventilation of new dwelling units:

- Allowing zero lotline development created situations where unit modules were in party with other units on all but one side. In these cases less than 1/3 of the units' perimeter walls can be opened up to light and fresh air. Although this condition is technically possible, with such narrow units (20 ft. deep), it is far below the norm in this block of detached homes.

3. Private outdoor space:

- The original program and design guidelines provide for a minimum private yard 20 ft. deep x 30 ft. wide. In hindsight, this seemed too small an area for units set in this "suburban" context.

4. Visual privacy for units:

- No initial design guidelines addressed

the positioning of pathways to units. The pathways generated sometimes run so close to units that it would be difficult to locate window openings in these walls without creating visual privacy conflicts.

5. Parking & car storage:

- In some schemes large parking lots were generated. This is out of character in this neighborhood where cars are parked singly or in groups of two or three.

6. Perceptions of open space--views through the block:

- The dwellings that exist generally have unobstructed views through to the other side of the block. Although maintaining this degree of openness is impossible, in consolidation involving detached structures, some views through the block should be preserved for the existing dwelling

units. Much of the consolidation generated in the Design Explorations blocked the views completely.

Evaluation criteria

1. Massing of new construction:
 - Buildings greater than 70 ft. in length (two-35 ft. unit modules) were considered unacceptable. This length matches that of the largest existing structures on the existing site.
 - Two-story structures within 60 ft. of the existing homes were judged undesirable.
2. Daylighting & natural ventilation of new dwelling units:
 - Unit modules that had 50% or more of their perimeter walls in party with another unit were not acceptable.
3. Private outdoor space:
 - Units which had only the minimum private use yard as prescribed in the original design guidelines were considered unacceptable.
4. Visual privacy for units:
 - Pathways to "backlot" units which were positioned within 10 ft. of other units create unacceptable visual privacy conflicts (assuming glazed openings occur). This dimension is derived from Edward T. Hall's charts of visual acuity versus distance in THE HIDDEN DIMENSION (see bibliography).
5. Parking and car storage:
 - Grouping more than five cars together in a parking lot (or along a street) was judged unacceptable in this context. This was based primarily on Christopher Alexander's guidelines prescribed in A PATTERN LANGUAGE (pattern 22).

6. Perception of open space:

- Consolidation which blocked more than 2/3rds of the views through the block past the centerpoint was considered unacceptable.

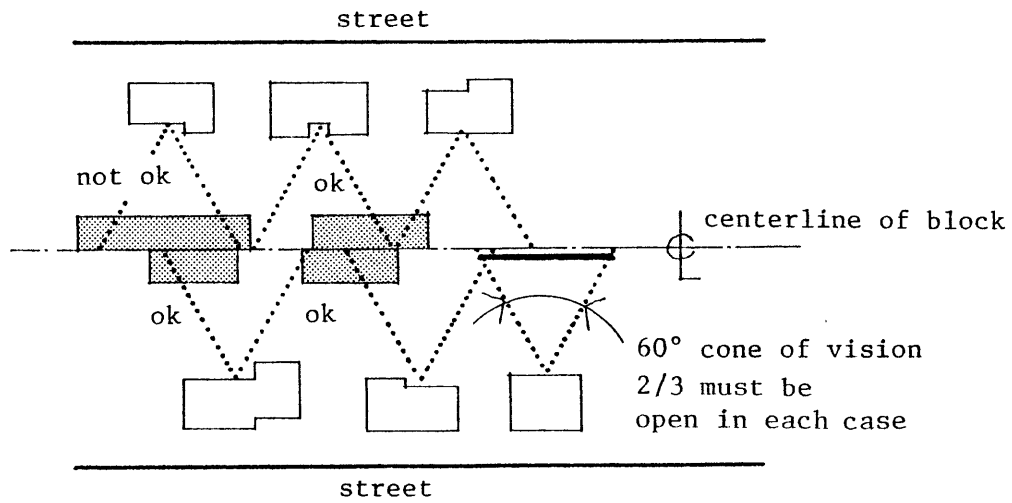

Qualitative Analysis

Design Explorations	1. massing of new construction	2. daylighting & ventilation of	3. private outdoor space	4. visual privacy for units	5. parking & car storage	6. perception of open space-- views through the block	7. overall ratings*
1A							10
B							15
C							12
D							11
E							2
F							8
G							9
2A							12
B							14
C							10
D							10
E							3
F							10
G							6
3A							1

Percentage of the projected consolidation that failed to meet the minimum quality criteria

- 0%
- 25%
- 50%
- 75%
- 100%

* Measured in "quarter circle" increments, the amount of projected consolidation which failed to meet the minimum quality criteria.

Reviewing the chart which summarizes the results of the qualitative analysis, one can gain a clearer understanding of the relationship between the developmental approach and the potential environmental impacts. Some of the most outstanding relationships are listed below.

- Subdivision of the existing dwelling units (3A) had little impact on the block.

- There was a considerable qualitative difference in the schemes that consolidated single lots using only the existing street system for access (1A & 2A) and those that had a new street access (1E & 2E).

- The only major difference between the schemes that assumed lots along a street had been grouped (1B & 2B) and those that assumed through block pairs to be grouped (1C & 2C) was on issue number 6 (perception of open space--views through the block).

- Aggregating existing lots into larger units for consolidation has the potential of generating larger parking lots.

Consolidation Standards

The consolidation standards are a revised and expanded version of the initial design guidelines. They include growth limiting factors calculated to eliminate the kinds of consolidation criticized in the qualitative analysis. The standards have been listed under the quality issues that they were designed to address.

The Standards

1. Massing of new construction:

- Building forms:

- a) New construction shall not exceed the existing two-story height limit.
- b) Roofs must be pitched, if not designed as habitable outdoor spaces.
- c) No wall or roof plane shall be continuous for more than 80 feet, for one-story building types.

- d) No wall or roof plane shall be continuous for more than 40 feet, for two-story building types.
- e) A shift of 5 feet or more must occur for a surface to be considered discontinuous.
- f) No single building shall be longer than 120 feet.

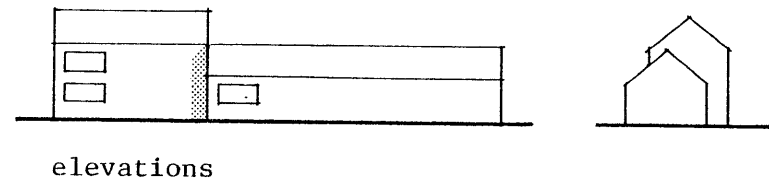
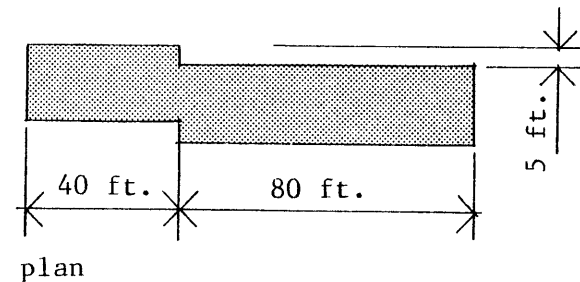

- Building setback requirements:
 - a) 5 foot minimum side and rear yard setback, for one-story construction
 - b) 15 foot minimum side and rear yard setback for two-story construction
 - c) 20 foot minimum setback from the street

filling along the street use 10 foot minimum.

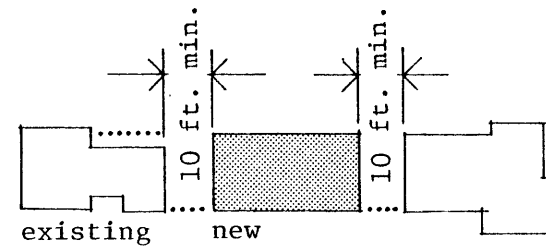

street

- Separation between buildings, all new construction:
 - a) 20 foot minimum when either building is two-story
 - b) 10 feet minimum when both buildings are one-story
- Separation between new and existing buildings:
 - a) 30 foot minimum for new one-story construction
 - b) 60 foot minimum for new two-story construction

Exception: When consolidation takes the form of new detached buildings in-

2. Daylighting & ventilation of new dwelling units:
 - a) No dwelling unit shall have more than 1/3 of its perimeter wall in party with another unit or storage space.
 - b) No space within a unit shall be more than 20 feet from an exterior wall.

3. Private outdoor space:

- a) Each ground floor dwelling unit shall have at least one private use yard.
- b) To be considered a private use yard it shall have no dimension less than 20 feet. (400 sq. ft. min.)
- c) Private use yards for new dwelling units can not fall within the street setback of 20 feet or a 30 foot setback from the existing dwelling units.
- d) In addition to the private use yards each ground floor dwelling unit shall have one other yard space (does not have to conform to the use yard standards).
- e) All second floor dwelling units shall have a minimum 6 ft. x 6 ft. deck space.

4. Visual privacy:

- a) Public pathways to dwelling units shall be set back from other new and

existing buildings by a minimum of 10 feet. Exception: pathways along existing "street" units where less than a 10 foot sideyard exists shall be positioned along the property line.

- b) Whenever possible position pathways to "backlot" units away from the "street" units' most private living spaces (bedrooms, bathrooms, etc.) and towards utility areas (garages, kitchens, etc.).

5. Parking & car storage:

- a) Provide off-street parking in the ratio of one space per 700 sq. ft. of new indoor living space.
- b) Provide storage garages in the ratio of 1 per each 3 spaces required.

<u># spaces req.</u>	<u># garage spaces</u>
1	0
2	0
3	1
4	1
5	1
6	2

- c) A maximum of 2 required parking spaces may be located within a 20 foot street setback, by any one land owner.
- d) Three parking spaces grouped together shall be considered a lot.
- e) A maximum of 7 spaces may be grouped in any single lot.
- f) Parking lots may infringe on the existing dwelling units' yard space only along garage or utility spaces.
- g) Parking lots must be screened from view along street edges and property lines.
- h) No single landholder may develop parking lots spaced at less than 100 feet apart.

6. Perception of openspace--views through block:

- a) Each existing dwelling unit must be allowed view penetration through the block in the following manner:

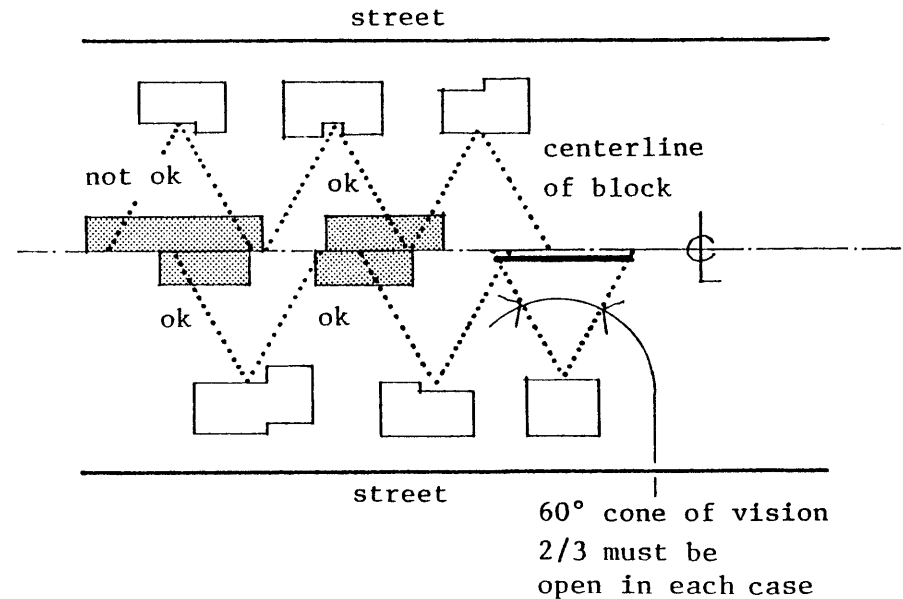

Assessing the Standards

Because the consolidation standards were designed to eliminate growth patterns criticized in the qualitative analysis we can be fairly confident that they will do so. What is really at issue here is whether or not these standards will produce other undesirable environmental impacts in the process? Also, would they prove to be too restrictive to growth if applied?

Four of the fifteen schemes studied in the Design Explorations were singled out for re-examination in this section (1B, 1C, 2B & 2C) because time did not permit restudy of them all. These all received very unfavorable ratings in the qualitative analysis and would therefore be amongst the developmental approaches most affected by the introduction of the standards.

In the initial Design Explorations one and two-story consolidation types, detached:

type 1 and detached: type 2, were examined separately. This was done so that the impacts of each would be drawn out for analysis. Now that this evaluation has been completed and a set of rules made governing the placement of detached unit types by height, these two forms can be explored simultaneously. Schemes 1B and 2B become a single approach designated (1+2)B. Similarly 1C and 2C become (1+2)C.

Some assumptions about the deployment of detached units carry over from the initial Design Explorations.

1. Always develop the lot(s) from the most remote position available, towards the existing structures.

Exception: where the lot configuration allows infill in line with the existing "street" units develop this first.

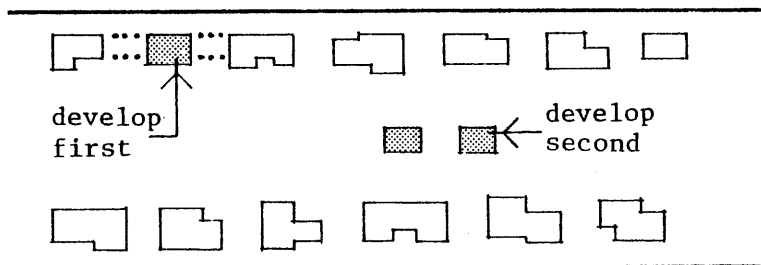

2. Always link single dwelling unit modules together into larger buildings as permitted within the consolidation standards.
3. Maximize the dwelling unit count in these studies.

The reconfigured schemes have been presented in the same format used in the initial Design Explorations so that comparisons could be made more easily.

(1+2)B

Overall Site Plan

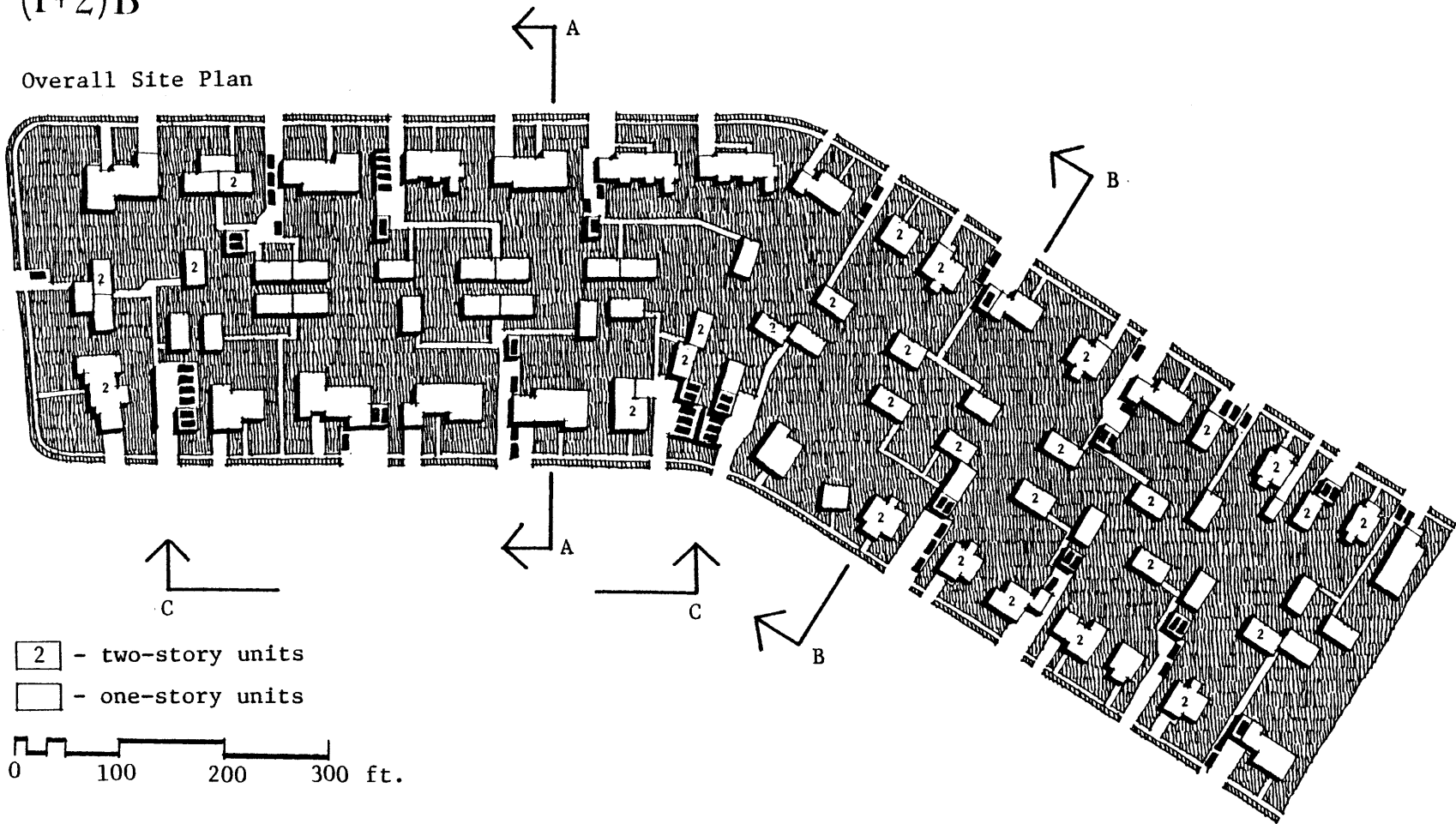

- 2 - two-story units
- one-story units

0 100 200 300 ft.

Section C-C

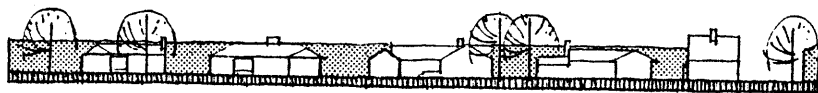

0 50 100 ft.

Land Aggregation Assumed

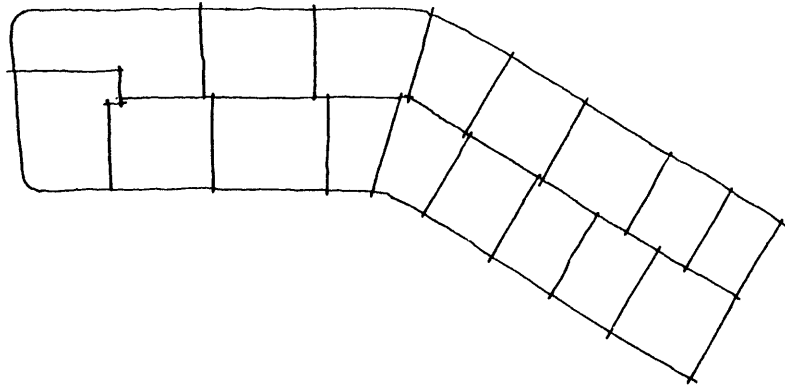

Public Circulation Pattern Generated

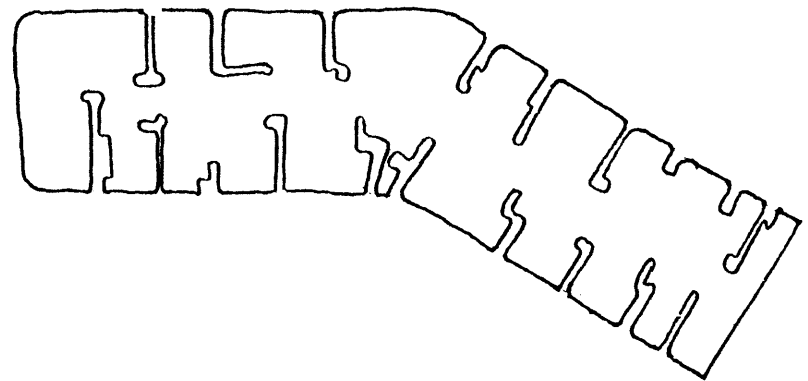

Settlement Pattern Generated

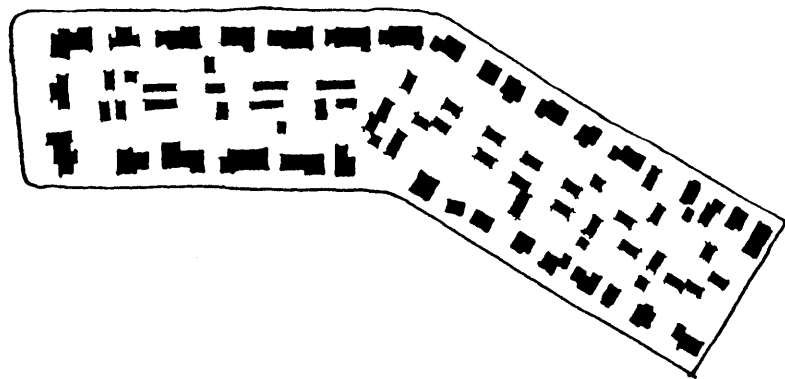

Parking Distribution Generated

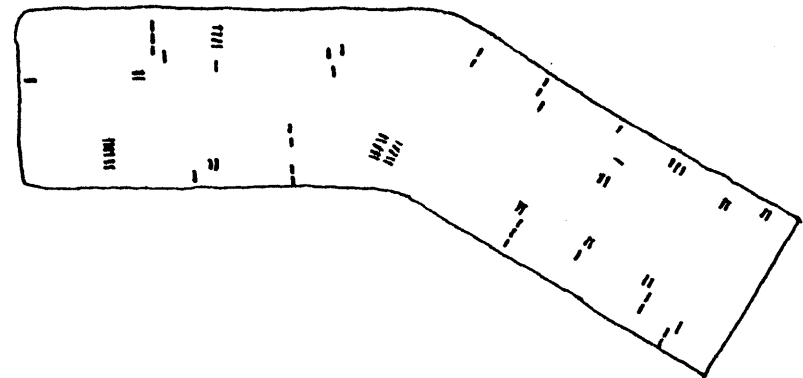

Section A-A



Section B-B

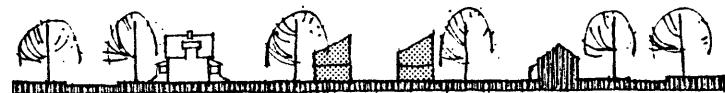

(1+2)C

Overall Site Plan

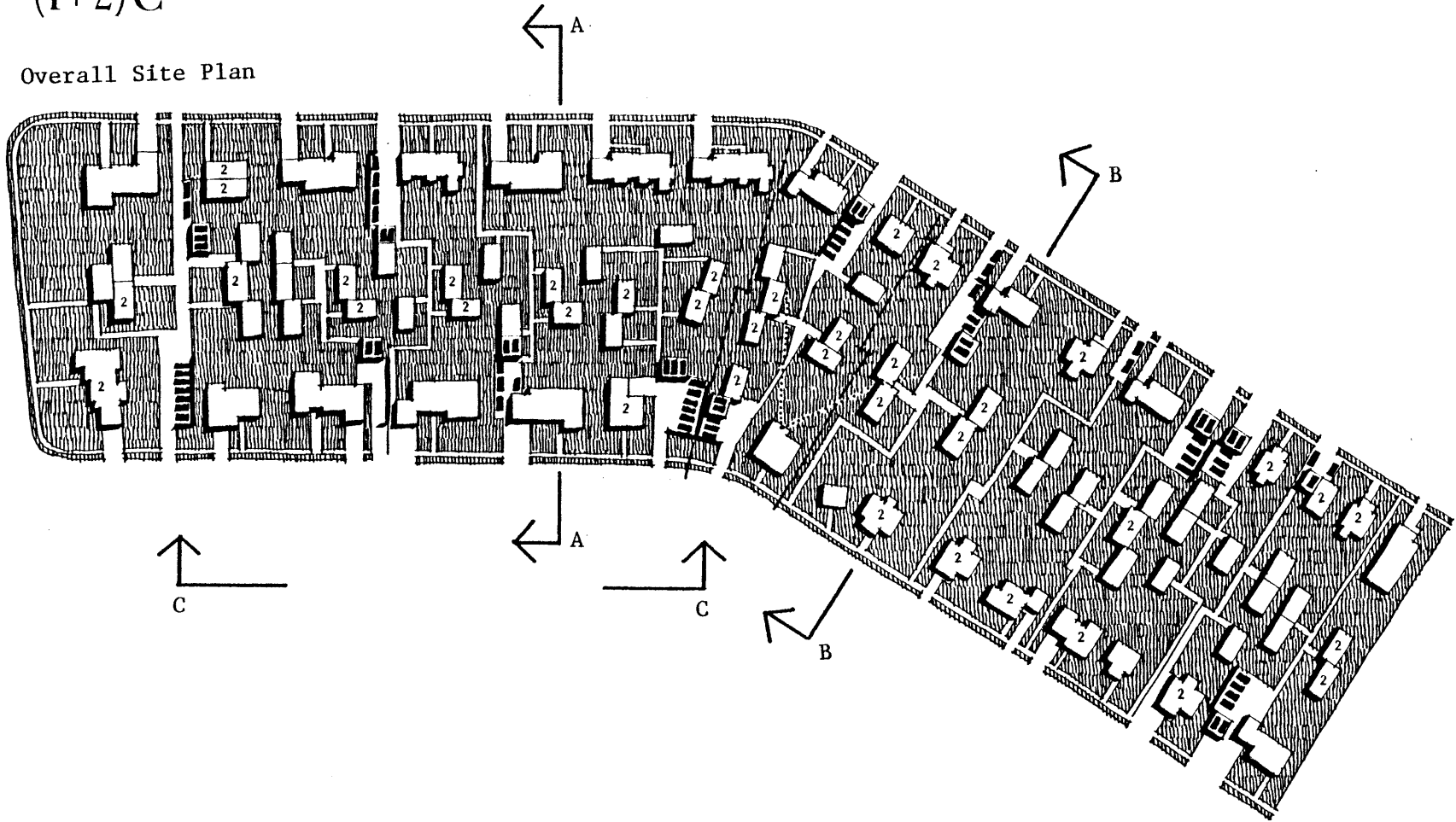

Section C-C

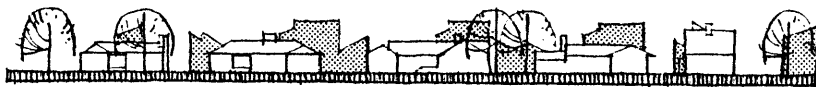

Land Aggregation Assumed

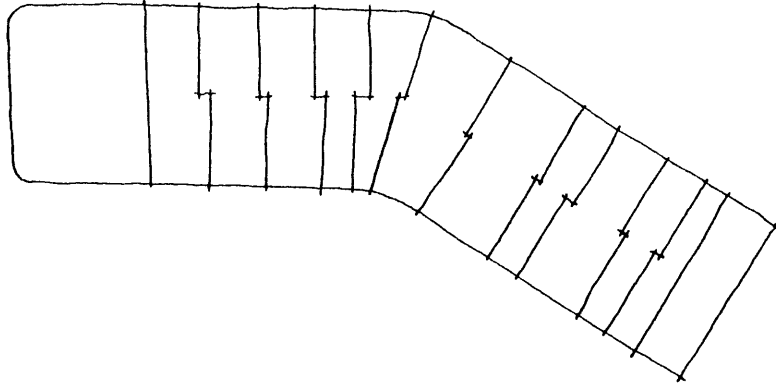

Public Circulation Pattern Generated

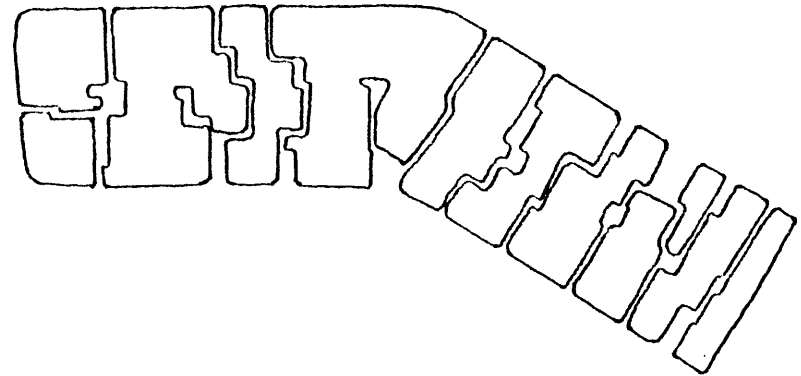

Settlement Pattern Generated

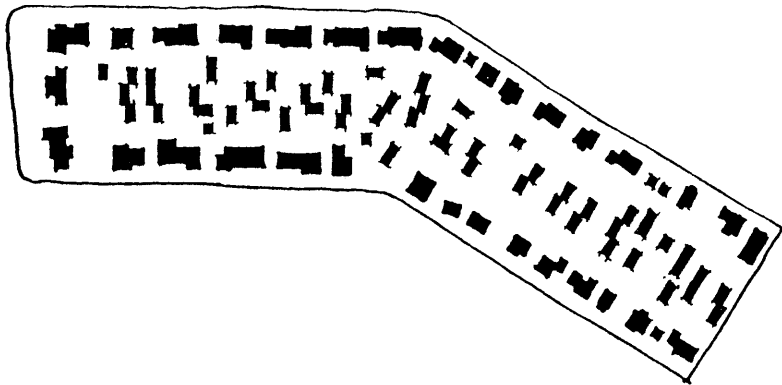

Parking Distribution Generated

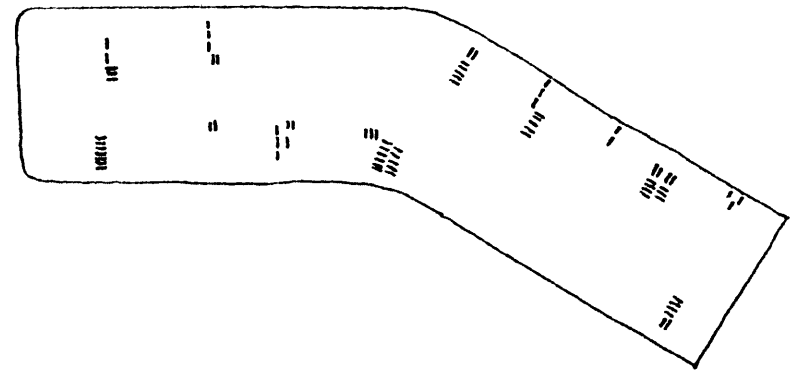

Section A-A

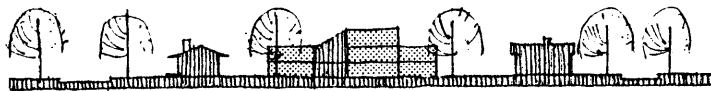

Section B-B



QUANTITATIVE ANALYSIS																																				
Design Exploration	1. dwelling unit count, total			2. dwelling unit count, number on grade			3. dwelling unit count, number above grade			4. site coverage (%), dwelling unit footprints			5. site coverage (%), paving			6. site coverage (%), total columns 4&5			7. sewers & utilities (LF), minor lines			8. sewers & utilities (LF), major lines			9. sewers & utilities (LF/unit), total columns 7&8			10. auto paving (SF), minor work			11. auto paving (SF), major work			12. auto paving (SF/unit), total columns 10&11		
	EX	30			30	0		11.2	4.5	15.7	--	--	--	--	--	--	--	--	--	--	--	--	--	--	--	--	--	--	--	--	--	--	--			
1B	192			111	81		24.3	27.0	51.3	4700	0	29	48300	0	298																					
1C	194			112	82		24.4	30.9	55.3	4500	0	27	66000	0	402																					
2B	117			117	0		29.2	20.5	45.7	4700	0	54	26400	0	303																					
2C	112			112	0		24.4	23.4	47.8	4500	0	54	33000	0	402																					
(1+2)B	65			48	17		19.6	14.5	34.2	3900	0	61	42500	0	654																					
(1+2)C	83			57	26		20.6	14.9	35.5	3500	0	42	43500	0	524																					

My assessments of the consolidation standards, based on this limited examination alone, are as follows:

- The rules developed to maintain openness through the block are potentially the most restrictive and perhaps should be questioned.

- No new undesirable environmental impacts resulted from the application of the standards.

- These standards are in fact successful devices for maintaining the intrinsic "suburban" qualities of this setting.

CONCLUSIONS

- The consolidation standards presented within are in many ways perhaps too safe. They assume that all land owners will consolidate and impose restrictions based on total consolidation of the block. This is probably not a reasonable scenario but perhaps the only way to approach the issue in a democratic way.
- I believe there needs to be a clearer understanding of how dense landscape screens might allow greater increases in unit capacity without creating environmental impacts of greater severity. This issue was not addressed in this study.
- The work presented within this thesis could certainly be expanded on and I think the efforts would be worthwhile.

BIBLIOGRAPHY

Alexander, Christopher, et al. A PATTERN LANGUAGE, New York, Oxford University Press, 1977.

Chandler, William (consultant to the) Re-development Division, Ministry of Housing, Victoria. DUAL OCCUPANCY: ADDRESSING THE MISMATCH BETWEEN HOUSING STOCK AND THE NEEDS OF HOUSEHOLDS, 1980.

Gellen, Martin. A HOUSE IN EVERY GARAGE: ECONOMICS OF SECONDARY UNITS, 1981.

Greenwald, Susan. ADAPTIVE REHABILITATION OF A RESIDENTIAL BLOCK, unpublished, M. Arch. Thesis, MIT, 1976.

Hall, Edward T., THE HIDDEN DIMENSION, Garden City, N.Y., Doubleday, 1966.

Hartman, Hattie. REHABBING THE SUBURBS: FREEDOM TO CHANGE, unpublished, M. Arch. Thesis, MIT, 1982.

Lerup, Lars. BUILDING THE UNFINISHED: ARCHITECTURE AND HUMAN ACTION, Sage Publications, 1978.

Newton, MA, Department of Planning and Development. HOUSING GOALS AND POLICIES: AN ELEMENT OF THE COMPREHENSIVE PLAN, 1977.

Newton, MA, Department of Planning and Development. POPULATION AND OPINION PROFILE: 1976-1980 TRENDS, 1980.

Perin, Constance. EVERYTHING IN ITS PLACE: SOCIAL ORDER AND LAND USE IN AMERICA, Princeton, N.J., Princeton University Press, 1977.

Sprague, Chester & Vernez-Moudon, Anne. CONSOLIDATION: A METHOD FOR EXPANDING THE USE OF SINGLE FAMILY HOUSING IN THE SUBURBS, unpublished research grant proposal, 1981.

Tunnard, B. & Pushkazev. MANMADE AMERICA: CHAOS OR CONTROL, New York, N.Y., Harmony Books, 1963.

Vernez-Moudon, Anne. CONSOLIDATION: EXPANDING THE USE OF SINGLE FAMILY SETTINGS, Design Studio, University of Washington, Seattle, Washington, Fall 1981.

Vernez-Moudon, Anne & Sprague, Chester & Hartman, Hattie. HOUSING CONSERVATION: INFILL AND CONSOLIDATION, Lincoln Institute of Land Policy Paper, 1981.

Vernez-Moudon, Anne & Sprague, Chester. MORE THAN ONE: SECOND LIFE FOR SINGLE FAMILY PROPERTY, Lincoln Institute of Land Policy Paper, 1981.