

**THE REAWAKENING OF
THE CHINESE HERITAGE THROUGH
A CULTURAL EMBASSY:
TRANSFORMATION OF THE CHINESE
ARCHITECTURAL LANGUAGE**

by

Horacio Y.W. Chin

Bachelor of Arts
University of California at Berkeley
Berkeley, California
1982

SUBMITTED TO THE DEPARTMENT OF
ARCHITECTURE IN PARTIAL FULFILLMENT OF
THE REQUIREMENTS FOR THE DEGREE OF
MASTER OF ARCHITECTURE
at the
MASSACHUSETTS INSTITUTE OF TECHNOLOGY
JUNE 1988

Copyright © 1988 Horacio Y.W. Chin

The author hereby grants to M.I.T. permission
to reproduce and to distribute publicly copies
of this thesis document in whole or in part.

Signature of Author _____

Horacio Y.W. Chin
Department of Architecture
May 6, 1988

Certified by _____

Yim Lim
Lecturer, Department of Architecture
Thesis Supervisor

Accepted by _____

William Hubbard, Jr.
Chairman
Department Committee for Graduate Students

MASSACHUSETTS INSTITUTE
OF TECHNOLOGY

JUN 2 1988

LIBRARIES
Rotch

***THE REAWAKENING OF THE CHINESE HERITAGE
THROUGH A CULTURAL EMBASSY:
Transformation of the Chinese Architectural Language***

by
Horacio Y.W. Chin

Submitted to the Department of Architecture on May 6, 1988 in partial fulfillment of the requirements for the degree of Master of Architecture

ABSTRACT

A possible resolution to prevent a strong tight-knit ethnic community from diminishing is through a re-awakening to the heritage of the people. In this thesis I propose the creation of a CULTURAL EMBASSY to instill pride and arouse self-awareness of the well-educated Chinese first, and eventually the Chinese of all social levels in Boston to revitalize the entire Chinatown.

Architecturally, this proposed building will carry a uniqueness of its own: a kind of cultural form and vocabulary containing the expression of today's technology and embodiment of the perpetual Chinese ideology in a Boston context. The appropriate "Chineseness" will be identified through the use of cultural vocabularies of the Chinese architectural language.

Thesis Supervisor : Yim L. Lim
Title : Lecturer in Architecture

Dedicated to Alice

ACKNOWLEDGEMENTS

I would like to acknowledge a few people who have helped this document come into being.

To have *Yim Lim* as my thesis advisor was the most treasurable opportunity during my education at MIT. She guided me in looking at architecture from another angle. Her positive attitude, patient reasoning and sincere instruction have consistently motivated me throughout the semester. Her influence on my architectural thinking definitely shows in my design.

Tunny Lee's keen observation and unique insight of the direction of Chinese architecture has been inspiring. Thanks for his concern for my attempt to search for the appropriate Chinese architectural language in this thesis.

Gabriela Goldschmidt's comments on my design have been valuable. I simply cannot thank Gabi enough for her prompt editing of my writing which I have composed during the past two weeks.

I would like to thank *Renee Chow* for her comments and the sharing of her travel experience in China.

Bill Hubbard's thinking helped motivate my thesis topic regarding the reawakening of the Chinese heritage. Thanks for his concern during thesis preparation.

Also, I want to thank *Kent Duckham* and *James Moore* for their comments; *Andy Garvin* for helping me to resolve many problems in using Mactintosh. *David McCullough* and *Patrick Jackson* for letting me share their site model; *Jonathan Sinagub*, *Chiong Lin*, *Kairos Shen*, *Mark Daley* and *Tim Smith* for assisting the completion of the site model; and *Kairos* for photographing the model.

Finally, I would like to thank Alice, my wife, for her continuous support and patience during my MIT schooling, particularly for her discussion and help during my thesis.

PREFACE

It was late October 1985 -- my first time in Beijing, China. I was on top of the View Mountain looking at the Forbidden City from a distance. The sea of yellow tiled rooftops led my sight to the horizon where I saw a rim of concrete buildings surrounding this magnificent Imperial Palace. I felt sad to realize this traditional Chinese architecture would never be built again.

Strolling along Beijing streets, I saw building after building of a modern look which I could find in every new city in the world. I wondered if this was an inevitable consequence of China's the modernization movement. I guessed it was, eventhough it was not to my liking.

The bus stopped. I struggled to get off. We were on our way to the Friendship Hotel. Approaching the building, I noticed that this six-storey modern hotel was topped by a traditional Chinese roof. It was not bad, I thought -- at least it gave the impression of being in China. But still, something was lacking in this building - we cannot put traditional Chinese roofs on all new buildings to make them look Chinese.

On our last day in Beijing, we went to the Fragrant Hill Hotel where I found no traditional roof, nor any Tou-kung, nor any Zoochow garden. In front of me was a modern, yet Chinese piece of architecture. I was moved by its appropriate "Chineseness" inside and out.

At that moment I saw the light of hope -- the hope of the continuity of Chinese architecture through the use of a contemporary language derived from our roots. And at that moment my commitment to doing contemporary Chinese architecture in China began to take shape. And this commitment became my main motive to further my education in architecture, so that I could direct my ideas to Chinese architecture in the future.

It was September 1986 - my first time in Boston Chinatown. Looking around, I felt a sense of depression drifting through my blood. Why was the place so poorly maintained? Why did the people there look so apathetic?

Through conversations with people, particularly with Prof. William Hubbard during the thesis preparation course, the answer to my questions gradually emerged: it is the loss of pride in their heritage. The idea of *the reawakening of the Chinese heritage through the creation of a Cultural Embassy* began to take form and became my main thesis title.

To design a cultural center for the Chinese community definitely provides me with the opportunity to explore the *transformation of the Chinese architectural language* - and this became the subtitle of my thesis.

TABLE OF CONTENTS

	Abstract	3
	Acknowledgements	5
	Dedication	6
	Preface	7
	Table of Contents	9
Chapter One	Boston Chinatown: Then and Now The Need for a Cultural Embassy	11
Chapter Two	Evolution of Chinese Architecture: Technology, Culture and Architecture	19
Chapter Three	Site Analysis	33
Chapter Four	Problem Statement and Program	45
Chapter Five	Design Concepts	51
Chapter Six	Design Presentation	81
	Epilogue	125
	Bibliography	127

Chapter One
BOSTON CHINATOWN:
THEN and NOW
The need for a Cultural Embassy

*The history of America is not the history of
the few, but the history of many. . . we need
to produce people's histories of their own
communities.*
- Henry Adams



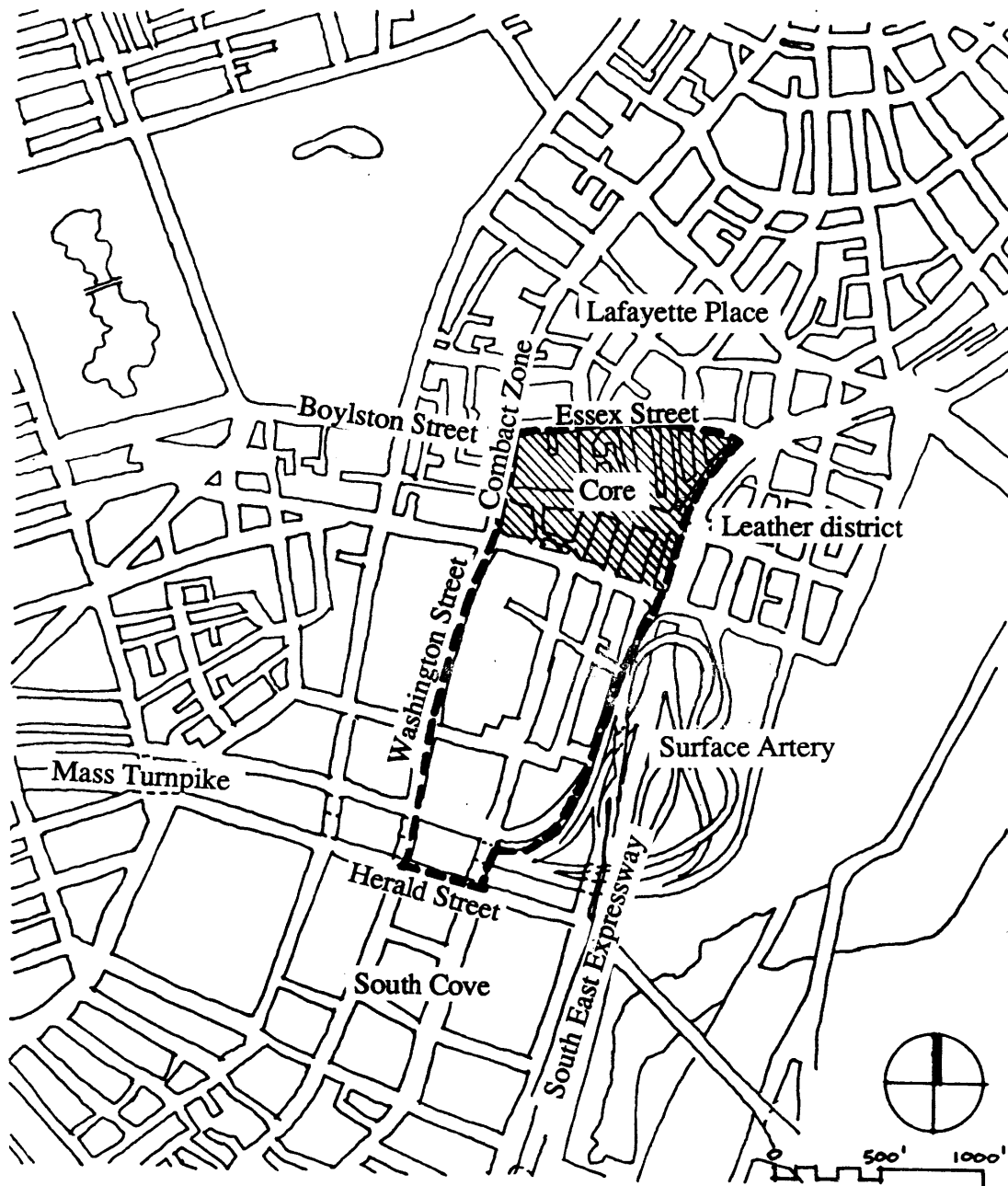

Fig. 1.1
Chinatown

--- Boundary of Chinatown

INTRODUCTION

The title of my thesis involves a social analysis of the Chinese community in Boston. It is necessary to briefly introduce its history and its current situation in order to explain my intention to design a Cultural Embassy for the future of Chinatown.

THE PAST

It has been over a century since the first Chinese came to settle in Boston. They were a group brought into Western Massachusetts from the West Coast to break a shoe factory strike. After the strike was over, now unemployed, many of them drifted to the larger cities. Some found employment as contract laborers for the Pearl Street Telephone exchange. Originally the men came to America only to earn some money and then returned to China; there was never an intention to stay. Unfortunately, due to China's unstable political situation since the turn of the century, many were forced to settle down here.

The newcomers first lived in a pitched tent along the narrow and crowded Ping On alley. Due to its massive railroad tracks construction nearby, the value of real estate in Chinatown sharply declined, thus making it affordable for the Chinese while the European started moving out of the area. Exclusionary immigration laws had kept growth at a minimal level until its repeal in 1943 repealing; Chinese women were then allowed to join their families, which then fostered the growth of Chinese population. The evolution from the "tent city" into a tightly knit neighborhood gave birth to today's fourth largest Chinese community in the United States.

THE PRESENT

Bounded today by Essex Street on the north, Herald Street on the south, the Southeast Expressway on the east, and Washington Street on the west, with Beach Street as the centre, Boston Chinatown has

become an area many groups are interested in. The inhabitable area of Chinatown not only has no expansion but rather was reduced by outside development, while population has doubled. This makes for crowded living conditions.

Chinatown has always been a tight-knit community. It is a place for the newcomer to adapt to a new life, a place for older residents to nurture their heritage. With its restaurants, grocery stores and gift shops, the Beach Street area has been a source of food, culture and friendship for the Chinese throughout New England. Its significance is not defined by geographic boundaries, but rather by its ethnicity.

However, being at a prime location, Boston Chinatown has been facing numerous problems: the construction of the S.E. Expressway in the 1950's caused the demolition of many housing units, the expansion of Tufts/ New England Medical Centre has been competing with Chinatown for land, and the completion of Lafayette Place signifies the blocking of Chinatown expansion to the north. (Fig. 1.1) This area is progressively undergoing surging development. The question of whether Chinatown is worth preserving has created strong controversy within the Chinese community. With a low economic value, Chinatown is in severe danger of disappearing as an identified entity. Chinatown must compete very hard for its existence with the surrounding districts.

As one of the few ethnic neighborhoods left in downtown and one with a century of history, Chinatown should have little difficulty proclaiming a reason to stay intact. However the question hinges on how it can maintain its economic stability compared to the neighboring districts. More importantly, for whom is Chinatown to be preserved? Is it for the new immigrant or for the established Chinese American who only comes to town for weekend shopping? Due to recent mega-development, the area of Chinatown has shrunk a great deal. There is hardly any space for expansion whilst the population continues to grow due to a large influx of immigrants who have flocked into Boston in the past decade. All these

have a significant negative impact on the community's social structure and environmental conditions.

Beset by congestion, old structures and high density, the residents and merchants must struggle to create a livable environment. A large number of educated, second generation middle-class Chinese have already started moving out of the area, and face many obstacles to coming to community activities, or in rejuvenating the place. Without everyone's cooperation and a strong desire to upgrade and revitalize the area, Chinatown will remain in a stagnated stage, a place with no value, a place constantly in danger of encroachment.

MY VISION OF THE FUTURE OF CHINATOWN

Many groups including the Boston Redevelopment Authority have concluded that the foremost issue that needs to be dealt with is housing. The continuous increase in population is far beyond the capacity of the limited space. Situated in an already high density area with open space at 6% of the recommended national standard, the Chinatown's housing problem will require years of thorough urban planning to formulate an effective way to accommodate the population growth.

There is no doubt that the housing problem is an important issue in Chinatown, but I believe this is not the long-term remedy to the issue of low morale mentioned above. Even if more housing is provided, two facts will remain true: first, more housing will still be demanded; second, Chinatown will still be of low value, vulnerable in face of mega-development.

Chinatown is located on a valuable piece of land. Even though housing is considered the most urgent need of the community, mere housing is still not the only solution. From the economic point of view, commercial development should always be included in any proposed projects in this area. It is understandable that the Chinatown residents cry out for more housing. But how much

housing is enough? I doubt it will be enough even if the whole New England Medical Center is torn down for a large housing estate. If this were done, the housing problem would have been alleviated to a certain extent. But, population growth will eventually reach a point that residents will again demand more housing. This is a vicious cycle of demand and supply: there is no final resolution.

Most local Chinese in the Boston area are well aware of the major Chinese festivals such as the Mid-Autumn Festival and New Year's celebrations. A big celebration is usually held in Chinatown. Due to limited outdoor space, several streets have to be blocked for such events. Other than these two activities, there are numerous other cultural functions being held on a regular basis in Chinatown. It is surprising to realize how few people know about it and how low the participation rate is. It could be due to the lack of advertisement, undesirable locations, or just merely lack of interest. However, the result is the loss of the native heritage. People no longer appreciate or sense the importance of their own cultural identity.

It is a pity to see a cohesive ethnic group such as the Chinese diminish gradually and become assimilated into the American mainstream. I believe that this assimilation could be stemmed if **the Chinese community could be reawakened to the profundity of its native culture.** I further believe that **an upgraded Chinatown could be a place that could instill in Boston's Chinese a pride in their heritage.** If this were so, the vicious cycle of low esteem producing an environment unworthy of esteem could be reversed: people would feel proud to work and live there; visitors would come to Chinatown for its cultural richness and unique resources, rather than just for shopping and dining.

In order to achieve this goal, we need a well-developed plan and appropriate people to be involved in it. I believe we need to utilize the well-educated Chinese and established organizations to carry out the task. But first of all, we have to reach out to this group of people to arouse their self-awareness. This renewed cultural pride would

have its most immediate impact if it could be instilled in the minds of the well-educated Chinese who now view Chinatown not as their home. Once they regain their cultural profundity, their sense of respect for their origins - once they visualize the importance of cultural continuity - they would be the best advocates to convey this message to the influential parties, the ultimate vehicle to the attainment of the goal.

WHY A CULTURAL EMBASSY

An *embassy* is a representative office of a nation in a foreign country. Any important messages or errands are being transected here. It allows exchange of information for their native people while in another country. My proposed Cultural Embassy serves a similiar role but with a different goal. This Cultural Embassy allows all forms of *cultural exchange* to take place here. It provides a place for the Chinese culture to be expressed, to be appreciated and to be nourished even though in a foreign place.

Elders come here to remember their golden age while watching traditional operas; youngsters would be given a chance to know more about their own heritage, their origin while browsing at their leisure. A sense of pride would begin to unfold within oneself. They would be proud of their origin and their today's being. People with different cultural background would view this Cultural Embassy as an image that signifies the cohesiveness of this ethnic group.

Architecturally, this Cultural Embassy is an attempt to bring out a unique identity of its own. It would contain a new form of language that expresses the Chinese perpetual ideology and the current technology. Such a high quality element would not only serve as a common place for cultural activities, it also could stimulate Chinese merchants to upgrade their business settings and to be more actively involved in the community. If all these could be fulfilled, who would question whether Chinatown is worth **preserving**, and who would doubt the value of this unique community.

Chapter Two
**EVOLUTION OF CHINESE
ARCHITECTURE:**
*Technology, Culture and
Architecture*

*Architecture is a Language not any different
from other forms of language, and I would
like to see the Chinese speak their own
language when it comes to buildings.*

- I.M. Pei



歷代木構殿堂外觀演變圖

EVOLUTION OF THE GENERAL APPEARANCE OF TIMBER-FRAMED HALLS

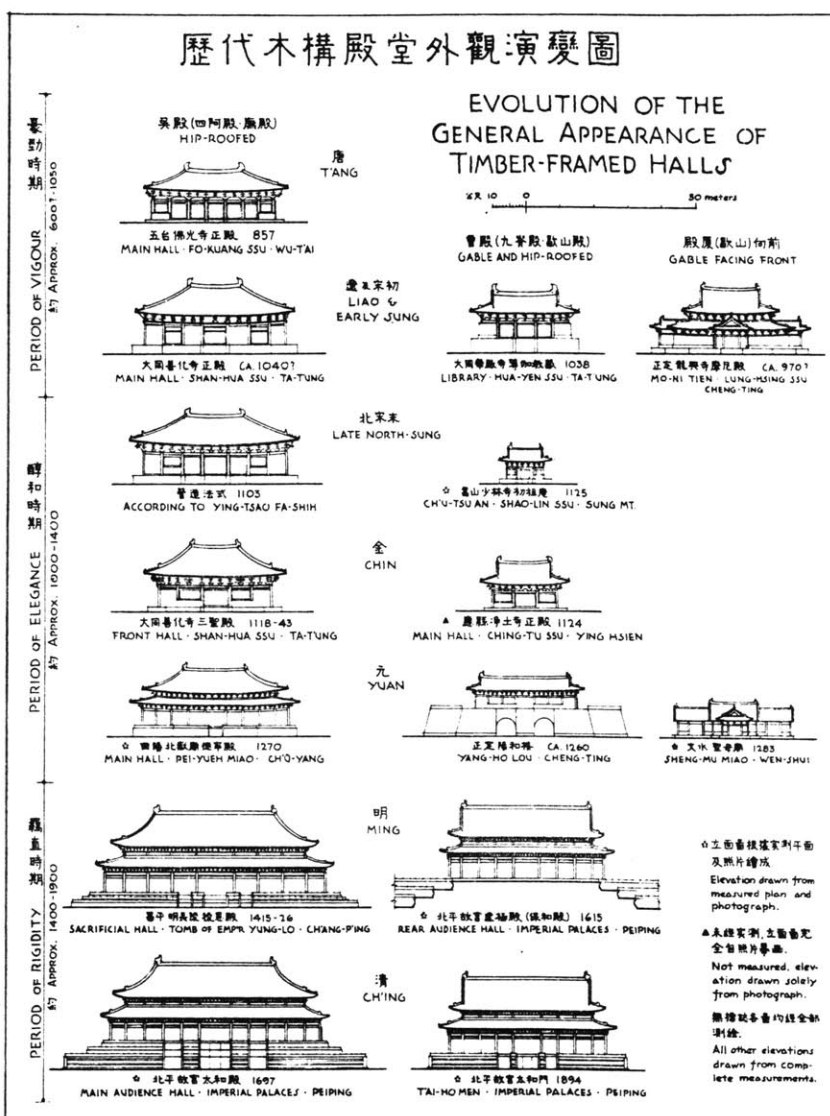

Fig. 2.1a Evolution of the general appearance of timber-framed halls

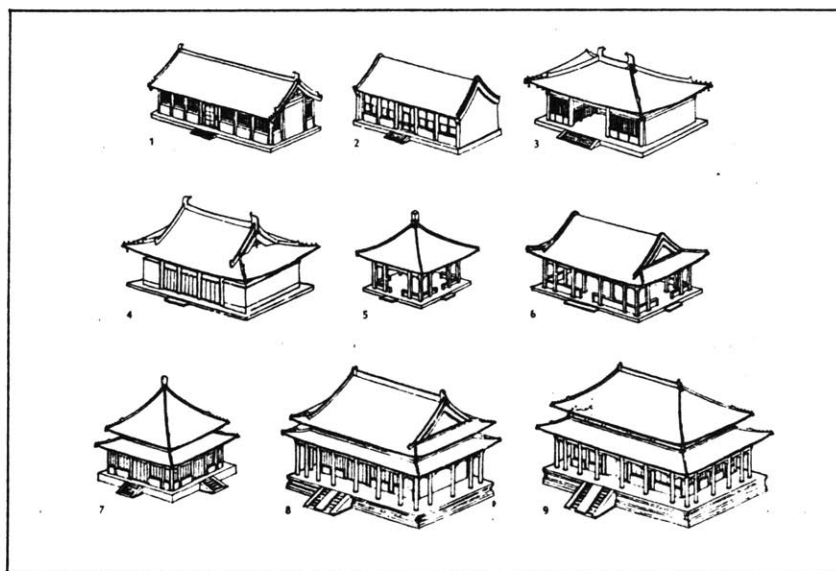

Fig. 2.1b Five types of roof

INTRODUCTION

The subtitle of my thesis touches on a very challenging issue: the transformation of the Chinese architectural language. The brief evolution of Chinese architecture discussed in this chapter prescribes the frame for my idea to derive the contemporary Chinese architectural language from cultural vocabularies and technological expression simultaneously.

EVOLUTION of CHINESE ARCHITECTURE

Ancient Chinese Architecture

China is a country with deep cultural traditions. Though China had, long in its history, started cultural exchange with the outside world and gained from foreign culture to enrich its own, the basic element of Chinese culture and custom has remained intact throughout its long history.

Architecture, as a cultural form, is also long standing and well established. Traditional building form remained viturally unchanged for several thousands of years until the turn of the century when a major transition took place. The ancient Chinese wooden structure was the basic and primary system in architecture. Buildings crowned with curved lofty roofs were prominent in traditional architecture. (Fig. 2.1) The significance of traditional domestic architecture was formed through long years of social structure, mode of life and cultural values of the feudal society. A big familiy with three or four generations living together was not uncommon. To allow some degree of privacy, it was necessary to provide individual units within a master building. A courtyard house, or houses related to a common courtyard at the centre, was the typical organization in the old days. (Fig. 2.2) The eldest, who was considered to be the master of the courtyard house family, was always situated in the middle facing the main courtyard and the others allocated their place according to a feudal hierarchy.

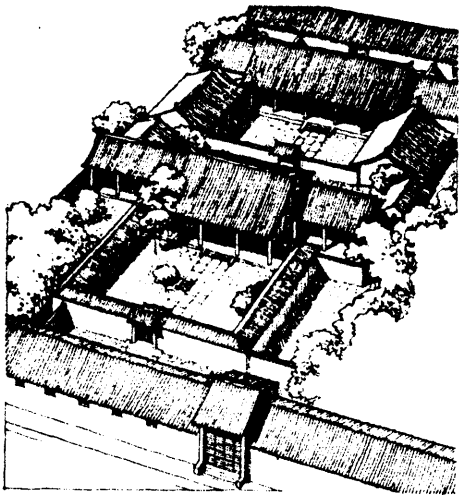

Fig. 2.2 (left)
Chinese courtyard house, Beijing,
China

Fig. 2.3 (below)
The Cultural Palace of Nationalities,
Beijing
An example of building which characterized
by towering roofs
over massive masonry walls with pierced
windows.

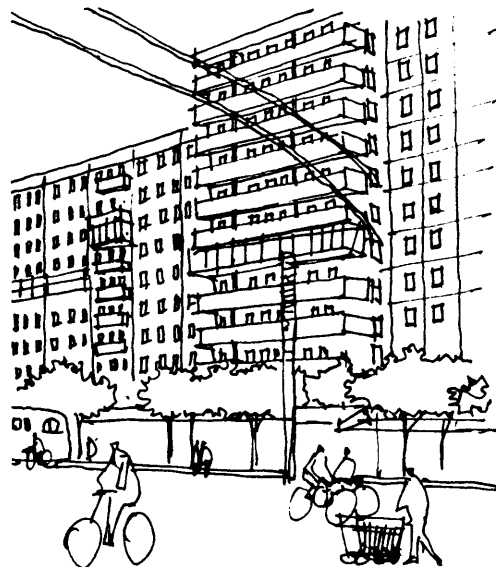

Fig. 2.4
Housing in Beijing
An example of the new types of
housing during the 1940's
after the establishment of the
People's Republic.

The courtyard arrangement and structural system were basically applied to all types of buildings for thousands of years. This is due to the social conditions and building techniques underlying the system, which had for long remained almost unchanged.

Western Influence

By force of arm and fire during the turn of this century, modern western civilization started to penetrate in all spheres of the Chinese culture. Colonial, Western-style neo-classical mansions, housing important banks and commercial corporations, were erected along the riverfronts in major cities like Shanghai, Tianjin and Canton. Most of these Western buildings were exclusively for the Westerners. These imperial type of mansion evoked a sense of bitter humiliation among the Chinese public. While the influx of western architecture aggressively swept into the big cities, a number of newly designed buildings, still made use of traditional Chinese palatial style for monumentality, were characterized by towering roofs over massive masonry walls with pierced windows. (Fig. 2.3) These extreme opposite trends led to a polarity in architecture during this period.

The 1940's

The establishment of the People's Republic in 1949 has implanted a new era and dimension to Chinese architecture. Feudal formalism of housing has faded away. A great number of residential quarters with new types of housing were built. (Fig. 2.4) Such projects, funded by the government, were aimed to enhance the living conditions of the working class people.

Industrial projects began in different provinces, bringing about rapid expansion of many inland cities, where millions of residential units were completed along with factories. Under large economic aid from the Soviet government, the Chinese architect had to follow Soviet ideology which advocated "socialism in content and

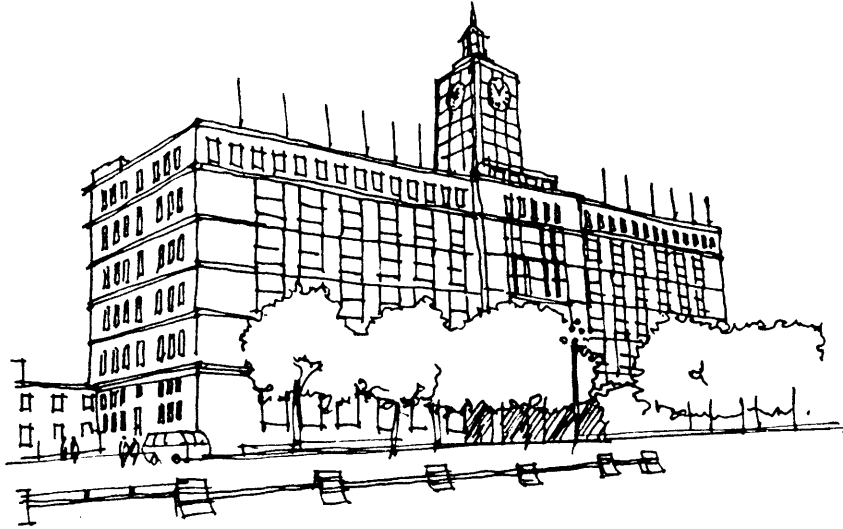

Fig. 2.5
The Telecommunication Building,
Beijing

An example of a new architectural style
which was designed according to the official
doctrines "functionalism, structuralism".

nationalism in form." "Practicality, economy and beauty under possible conditions" were their official guidelines. New factory buildings were mostly prefabricated reinforced concrete, but residential and civic buildings employed more or less indigenous technology characterized by multi-storey brick masonry structure with pitched tiled roofs. In villages and small towns, there still existed a rich variety of vernacular architecture. Aesthetic landscape in exquisite gardens continued to exist. However most of the government buildings were designed according to the official doctrines: "functionalism, structuralism", a new architectural style which is Chinese and socialist. (Fig. 2.5)

Cultural Revolution

This political turmoil has led to a dark age in every aspect of cultural form, including architecture. Schools of architecture in various universities were disbanded. Established well known architects were denounced either as feudal or capitalist. Buildings were required to carry portraits and revolutionary slogans. Architectural development was stagnated for more than ten years. This cultural movement caused profound damaged to the country.

Modernization Movement

After the crush of the cultural revolution, China resumed vigorous efforts to achieve modernization. Their goal was to upgrade their living standards and national economic status comparable to the Western world within thirty years. A series of new economic policies have tremendously stimulated the country's growth, especially in agriculture. To meet the needs of millions of people, massive residential buildings in urban areas were constructed every year. The open interchange trading policies have created a high demand for hotels and offices for foreign businessmen.

The architectural profession rapidly grew in importance along with the high technologies. The infusion of Western architectural

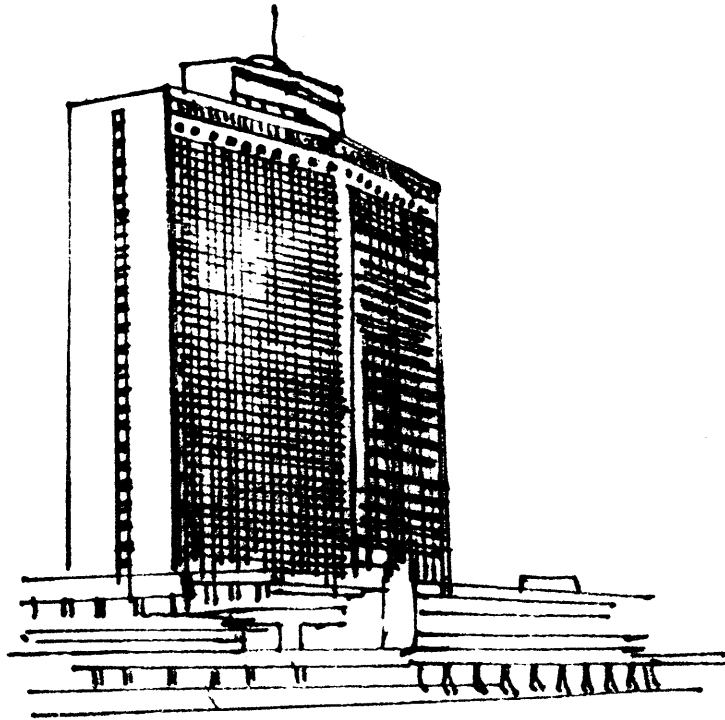

Fig. 2.6
White Swan Hotel, Quanzhou, China

concepts becomes a heated debate-issue among the younger architect. The question of how to integrate modernized design into the Chinese world without totally losing its identity is a major concern. A number of public buildings, mostly hotels, were constructed solely with the exhibition of western motifs, hardly within the context of their surrounding environment. (Fig. 2.6) In view of this trend, some have tried to advocate a style that is modern and spiritually Chinese: instead of rejecting or effacing the other, the ingenious synthesis of the two coexist.

TECHNOLOGY, CULTURE AND ARCHITECTURE

Despite the fact that the contemporary Chinese architecture with a cultural identity has been advocated, the general outcome of recent architecture has been disappointing. The impact of technology and Western influence is so tremendous that it has put the current architecture in danger: blindly accepting the Western style, consequently losing the native Chinese personality. It is perhaps the most challenging and critical moment in the history of Chinese architecture for our generation to reclaim the lost direction.

No matter how primitive or advanced it is, architecture should always reflect the technology of its time. Technology is a vehicle for the expression of architecture and architecture itself is an expression of technology - they are virtually inseparable of each other. On the other hand, architecture, as a kind of cultural form, should embody its native personality: through architecture a specific cultural identity should be reflected. Different forms of expression of architecture, same as different forms of art, make this world rich and diverse. From the discussion above, it is clear that architecture is the expression of both technology and culture. Lacking either one would definitely weaken the architectural framework.

The traditional Chinese wooden structure system remained unchanged for several thousand years until the late nineteenth century when the changes in social life and technical conditions

indicated that the old building system could no longer serve the changing world. New construction techniques were brought in to accommodate new housing projects, industrial and public buildings. The traditional tou-kung system was used to cantilever the wooden roof structure for rain protection purposes. Do we still want to employ this time-consuming construction technique and inflammable material to provide an overhang for a factory? Inapplicable old systems should be eliminated totally or if possible, transformed into new systems that could conform to the new requirements.

Highrises built during the 1930's topped with a traditional curved lofty roof (Fig.2.3) are a good example of architecture with the wrong expression of technology. Although it was an attempt to create some "national form" by using some classical elements, the application of curved lofty roof is taken too literally. To bring out the "*Chineseness*" does not mean to copy old forms directly. This should be achieved by searching for an appropriate Chinese architectural language. As a form of communication, an architectural language is composed of cultural vocabularies which are transformed and refined from a rich field of resources. The resources are derived from our roots, ranging from the abstract spatial concepts, symbolism to geometric motifs. "Transformation" is the key word in the derivation of such a language.

In designing Fragrant Hill Hotel, I.M. Pei has refined the architectural language by expressing the Chinese "vernacular". (Fig. 2.7) There is a spacious atrium in the hotel. (Fig. 2.8) Technologically, the traditional construction method is inappropriate to enclose this 105 feet by 110 feet columnless space. A steel space frame, a device of the modern engineering world, has been used to achieve this purpose. The architect has, in addition to expressing both current technology and native culture through architecture simultaneously, revived regional traditions and adapted a classic vocabulary for the hotel and for China at large.

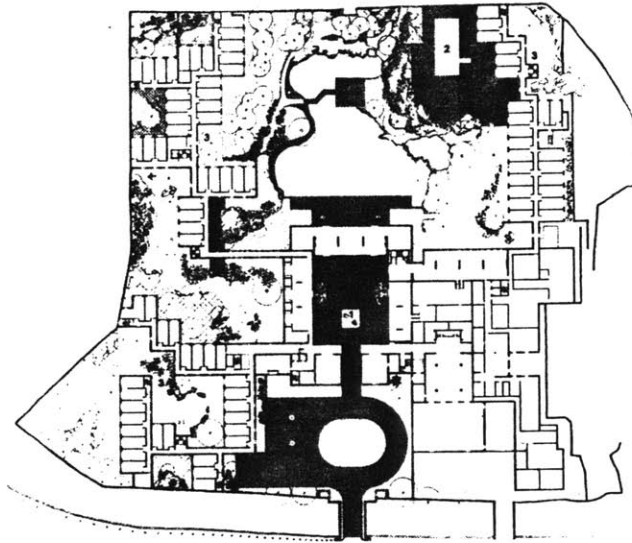

Ground floor plan

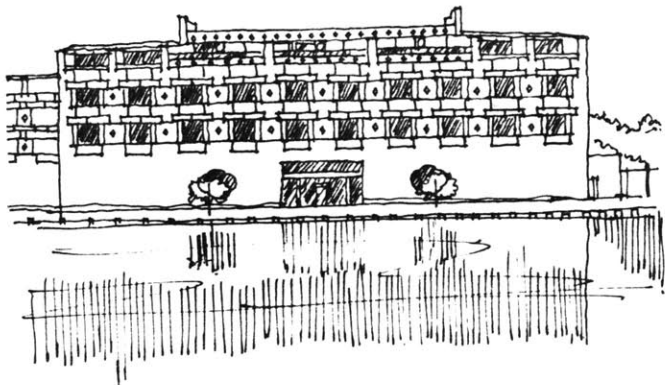

Courtyard side facade

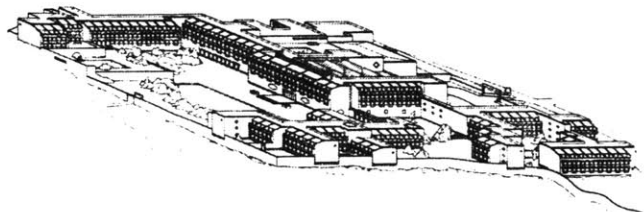

Axonometric

Fig. 2.7
Fragrant Hill Hotel
The personal expression of I.M.
Pei's "vernacular"

Current construction techniques have been introduced into China for some years. Now It is time to incorporate technology with culture to search for the appropriate Chinese architectural language, from which the direction of contemporary Chinese architecture will be found.



Fig. 2.8
The lobby of Fragrant Hill Hotel
The 105 ft by 110 ft atrium is enclosed by steel space frames.

Chapter Three:
SITE ANALYSIS



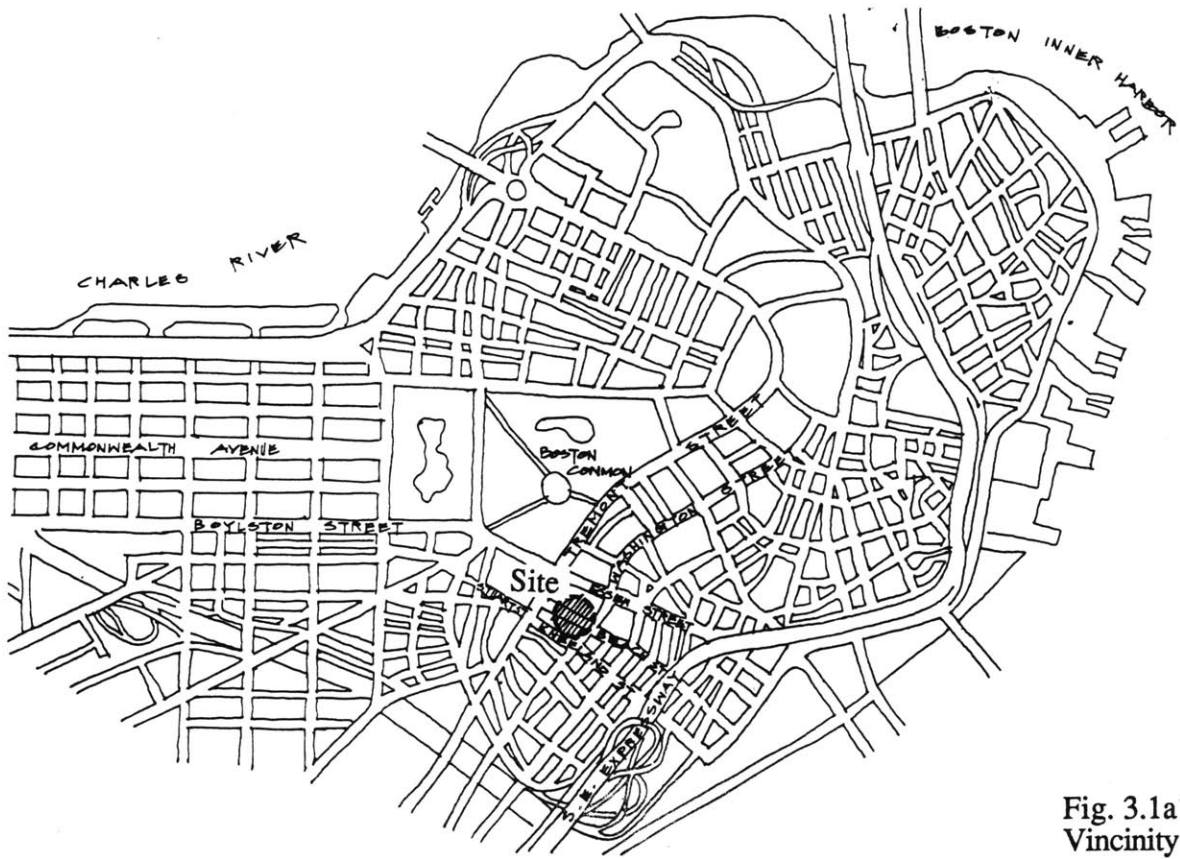

Fig. 3.1a
Vicinity Map

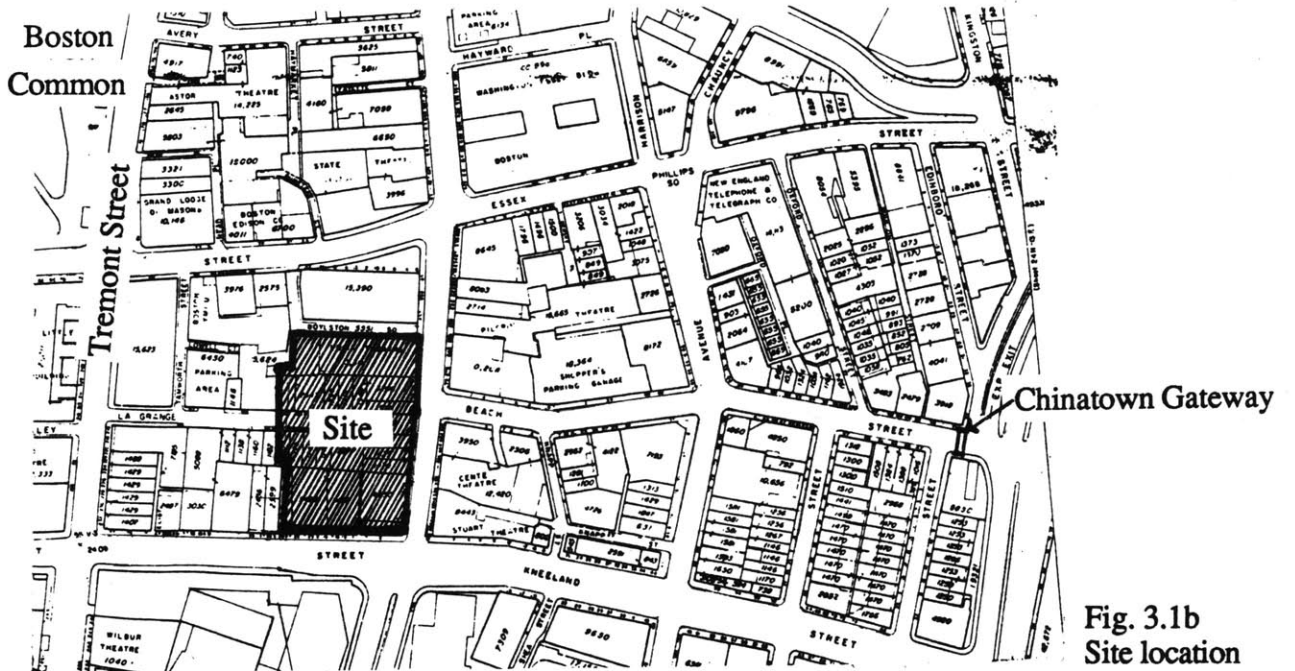

Fig. 3.1b
Site location

INTRODUCTION

Prior to testing concepts in a building design a Contextual analysis should be done to collect information about the site so that our early thinking about the building can rationally respond to external conditions. After screening the data, one would determine which concerns take priority over others. In this chapter my interpretation of context is discussed. Three kinds of contexts are categorized: *historical, physical and social Context.*

THE SITE

The site of the proposed Cultural Embassy is located in the southeast corner of the Boston city block defined by Boylston Street to the north, Washington Street to the east, Kneeland Street to the south and Tremont Street to the west. (Fig. 3.1a & b)

HISTORICAL CONTEXT

A number of buildings around the site have been identified by Boston City Landmarks Commission as landmarks. The following four landmarks are located within the city block of my proposed building (Fig. 3-2):

1. *Hayden Building* (1875) 681-683 Washington St. (Fig. 3.3)

This rusticated masonry Romanesque Revival style building is the last surviving Boston commercial building by H.H. Richardson and one of the only ten commercial examples by the eminent architect.



2. *Boylston Building, now China Trade Centre* (1887), 2-22

Boylston Street (Fig. 3.4)

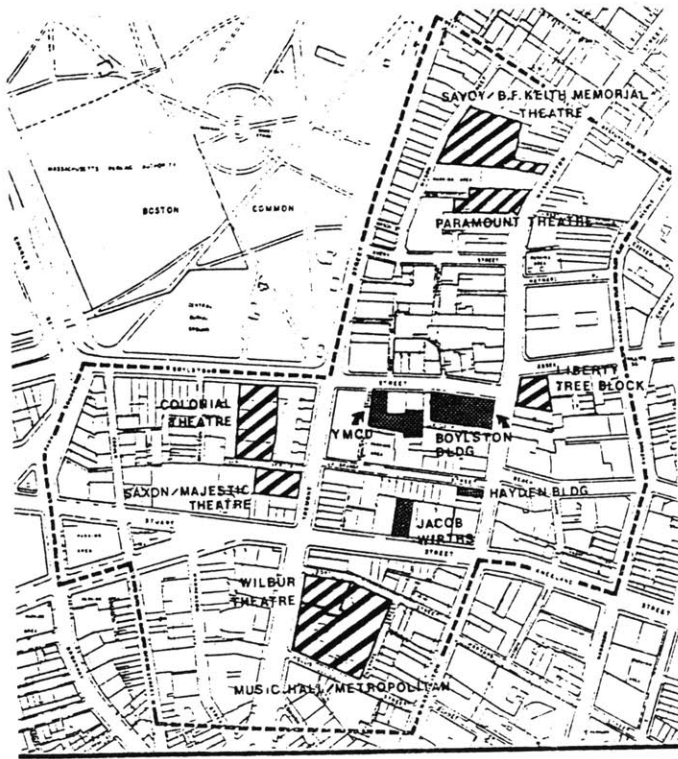
By architect Rare Fehmer, a distinguished design in a prominent corner location and an important example of the transition from traditional load-bearing masonry construction to the commercial style skeleton-framed building pioneered by the Chicago school.



BOSTON CITY LANDMARK RECOMMENDATIONS

-  PRESENT BOSTON CITY LANDMARKS
-  RECOMMENDED FOR CONSIDERATION
-  STUDY AREA BOUNDARY

BOSTON REDEVELOPMENT AUTHORITY



0 130 260 520 FEET



Fig. 3.3
The Hayden Building
This building lies within my proposed site

Fig. 3.2 (left)
Boston Landmarks
around the proposed site



Fig. 3.4
Boylston Building,
now China Trade
Centre

3. *Boston Young Men's Christian Union* (1875), 48 Boylston Street (Fig. 3.5)

Designed by N.J. Braslee, architecturally the most accomplished example of High Victorian Gothic in the survey area, important historically as the headquarters since its construction of the Boston Y.M.C.U., a Christian fellowship organization.

4. *Jacob Wirth's* (1844), 31-39 Stuart Street. (Fig. 3.6)

The only remaining Greek Revival bowfront residence in the survey area, notable historically as a German restaurant which has changed little inside or outside since its establishment there in the late 19th century.

In addition to the four landmarks above, the following seven buildings are recommended for consideration as Boston City Landmarks (Fig. 3-2):

1. Savoy/B.F. Keith Memorial Theatre (1982)
2. Saxon/Majestic Theatre (1903)
3. Colonial Theatre (1900)
4. Music Hall/Metropolitan Theatre, now Wang Centre (1925)
5. Paramount Theatre (1932)
6. Wilbur Theatre (1914)
7. Liberty Tree Block (1850)

In reality, the *historical context* becomes a design constraint. Particularly, *since the Hayden Building lies within my proposed site, to synthesize it into the design is essential*. The importance of preserving historical buildings will be discussed in chapter five: Design Concepts.

PHYSICAL CONTEXT

Most buildings around the site were built in the 1930's to 1960's, ranging in height from five to ten storeys. The main finish materials are red brick and white stone. Many of the buildings hug the street in such a way that the edges of the city block are clearly defined. The Transportation Building, built in 1983, is an good example of



Fig. 3.5
Boston Young Man's Christian
Union

Fig. 3.6
Jacob Wirth's

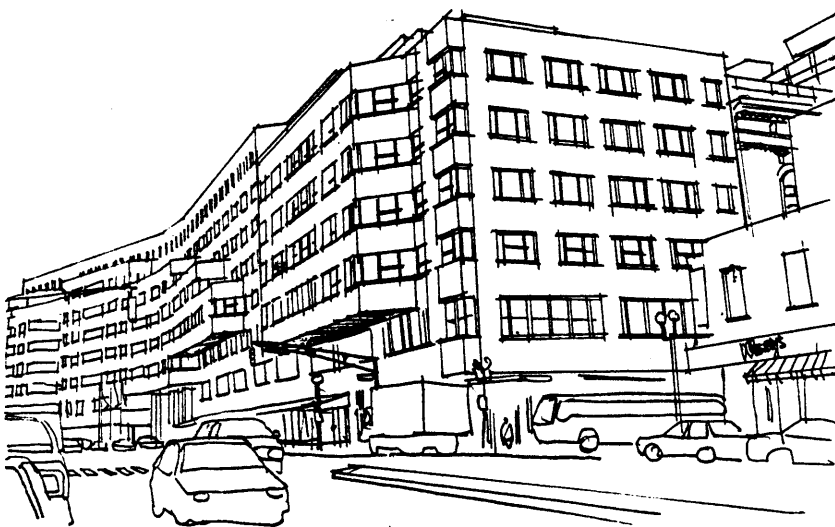

Fig. 3.7
Transportation
Building
The way this building
hugs the street strengthens
the bend in Stuart street.
Boston's unique street
pattern has been negated
by insensitive
development that has
imposed regular geometry
onto the irregular fabric.

keeping the city fabric consistent in terms of the use of materials, the building height and the way it strengthens the bend in Stuart Street. (Fig. 3.7) On the contrary, the Tufts /New England Medical Centre built in 1982 , is a failure: it pays no attention to the context. The outcome is a 16-storey highrise entirely alien to its neighboring buildings. (Fig. 3.8 & 3.9) From the examples above, it is obvious that *to design without considering the physical context would result in buildings doing damage to the existing strong city fabric.*

The Orange Line Chinatown subway station, situated at the intersection of Washington Street and Boylston Street, is only half a block from the proposed site. The Green Line Boylston subway station, located at the southeast corner of the Boston Common, is one block away. Also, there are a few bus lines serving this area. *With all these public transportation facilities around the site, the proposed building would be easily accessible.* In Boston, good public transportation service is one of the factors in the making of a successful public building. (Fig. 3.10-3.11)

SOCIAL CONTEXT

A few districts collide into this city block, making it a "hinge block": Chinatown core to the east, the Theatre District along Washington Street to the north, the Theatre District along Tremont Street to the southwest, and the Tufts/New England Medical Centre to the south. (Fig. 3.12-3.15) Currently, the proposed site is part of the Combat Zone, which is situated along Washington street, between Boylston Street and Kneeland Street. A number of adult entertainment licence renewals have recently been revoked, implying the intention of revitalizing this valuable area for upgraded development. Due to the "hinge block" nature of the site, the proposed building becomes a pivot for the different places mentioned above. This *social context* is so strong that it cannot be overlooked. *To provide continuity of public movement will be an important design criterion.*

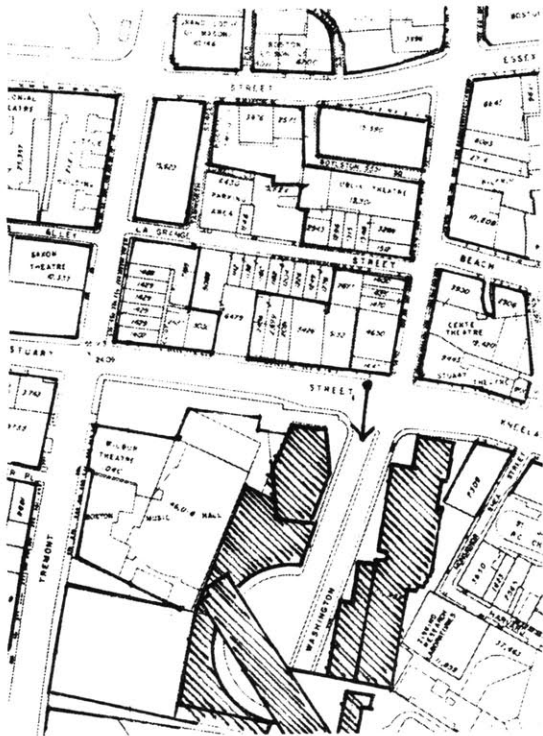

Fig. 3.8
Tufts/New England Medical Centre
 An example of architecture which give no attention to its context. Note that all other buildings hug the street so as to keep the fabric of the city.

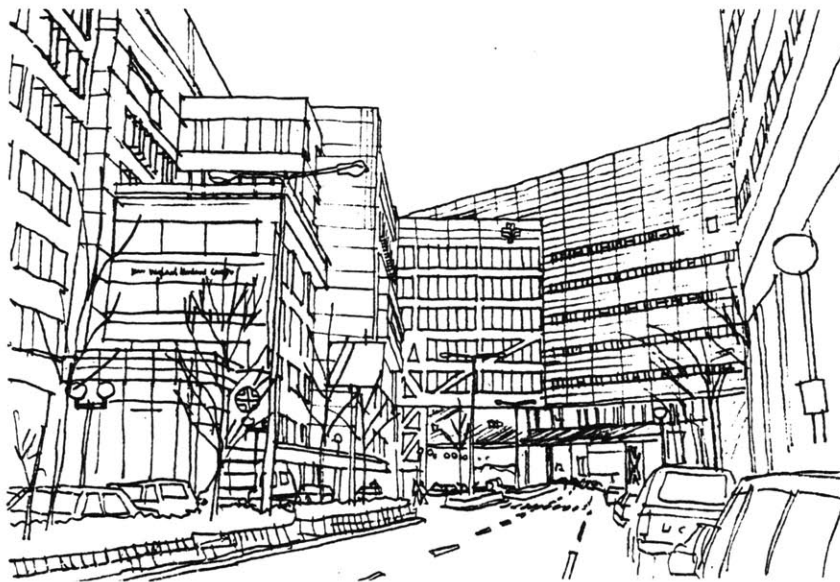

Fig. 3.9
The Tufts New England Medical Centre

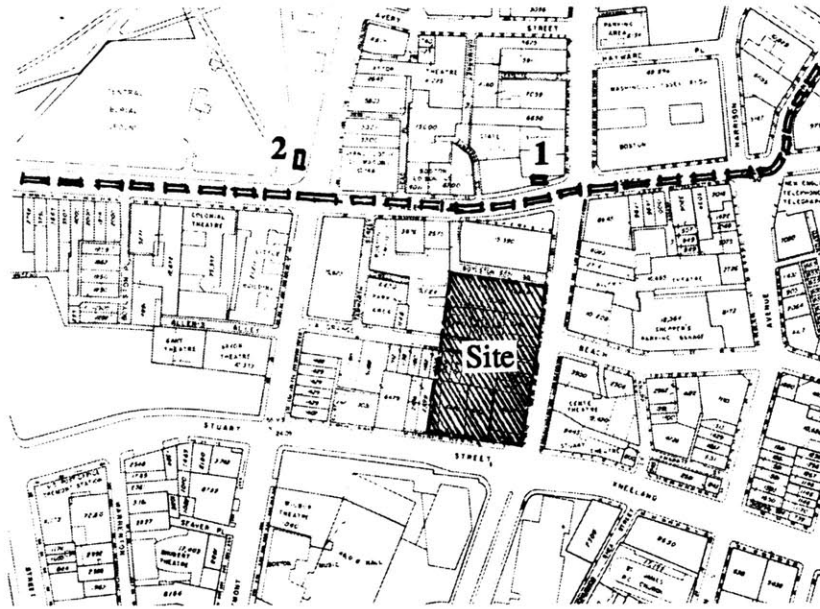

Fig. 3.10
Public Transportation
 1. The Orange Line Chinatown subway station
 2. The Green Line Boylston subway station
 — — — Bus line

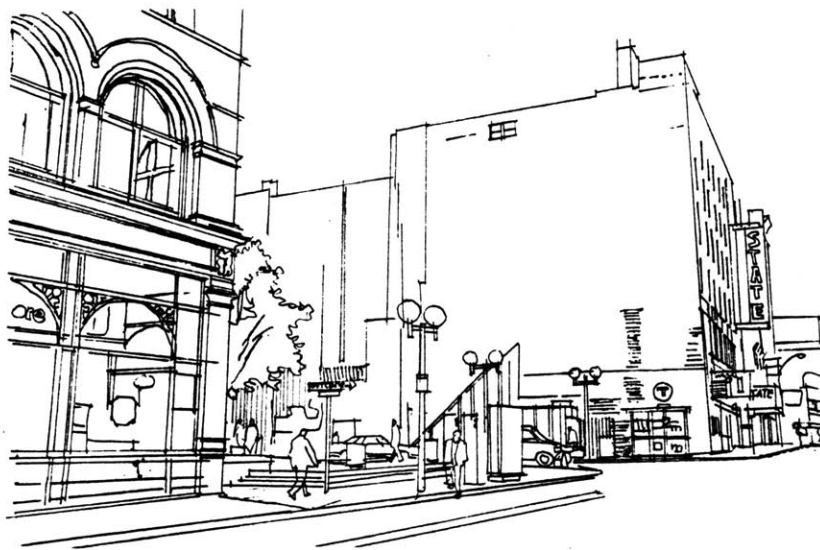

Fig. 3.11
The Orange Line Chinatown subway station
 This station is one block from the proposed site

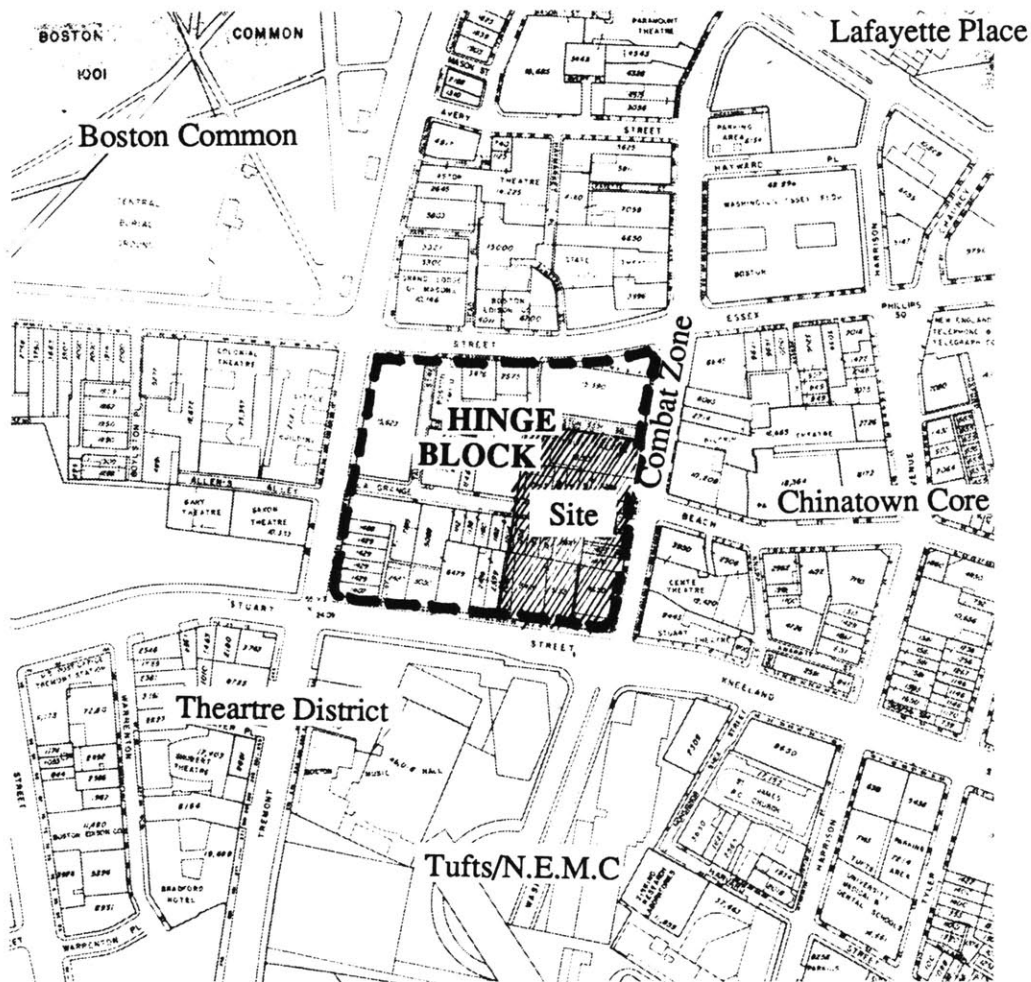

Fig. 3.12
 "Hinge Block"
 A few districts collide into this city block

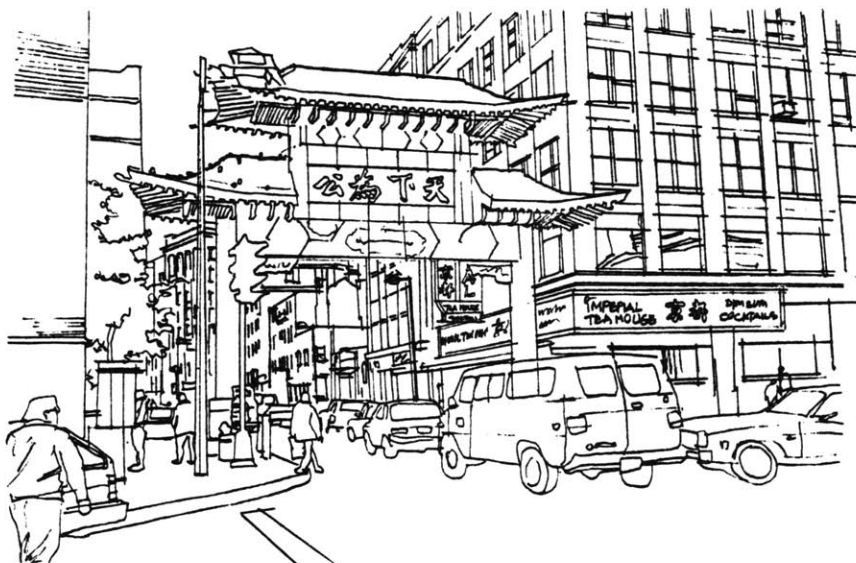

Fig. 3.13
 Chinatown Gateway
 on Beach Street

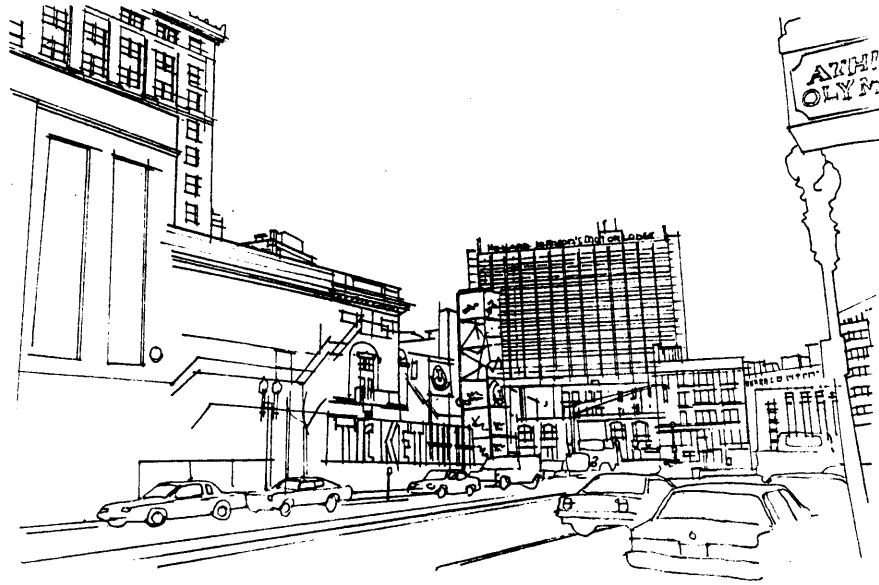

Fig.3.14
Backstage of Wang Centre across Kneeland Street
View from the proposed site looking towards Tremont Street



Fig. 3.15
The central part of the city block is currently a parking lot.

Chapter Four:
**PROBLEM STATEMENT and
PROGRAM**



INTRODUCTION

Every project is unique and has its own set of problems that need to be resolved. In "Problem Seeking: An Architectural Programming Primer", William Pena says that "*programming* is problem seeking and *design* is problem solving." Also, "*programming is distinct and separate from design.*" He goes on to explain that the bases for programmatic information are "*function, form, economy and time*", and programming should be considered in terms of a five-step method: "to establish *goals*, to collect, organize and analyze *facts*, to test *concepts*, to determine *needs*, and finally to state the *problem*." He concludes that to derive an explicit statement of an architectural problem is the ultimate goal of programming. And this problem statement with the space-requirement program is the hand-out package from programmer to designer.

PROBLEM STATEMENT

Function

Due to the lack of an identified place for cultural activities in Chinatown, there is a need to achieve a strong sense of place to let Chinese culture continue and nourish the community. This in turn would reawaken the native heritage of the Chinese in Boston.

In order to survive financially in this prime location, certain area should be rented out for commercial use so as to generate revenue.

Besides the cultural and commercial activities, the building should provide public spaces for people to gather.

Form

One of the intentions of the project is to extend Chinatown Core along Beach Street into the proposed building, so as to provide a well defined entrance.

Another contextual need to be addressed is public movement between the proposed Cultural Centre and the Theatre District at the intersection of Stuart Street and Tremont Street.

Since China Trade Centre is a commercial building with retail on the first three levels, it would be beneficial if a link could be provided between the proposed new building and China Trade Centre.

In view of the future expansion into the rest of the city block on which the proposed building is situated, an entrance should be provided on the west side of the building.

Architecturally, the proposed Cultural Embassy should portray a modern design with a Chinese identity. (Further architectural goals result from a particular approach to the problem and are discussed in the chapter on design concepts.)

Economy

Although there is no budget limitation for this architectural exploration, materials and finishes should be carefully considered for a reasonable initial cost and their effectiveness in terms of maintenance costs.

Time

The possibility of future expansion, either of the building proper or of Chinatown Core, because of the success of this building, should be considered.

PROGRAM

The program is derived from the problem statement discussed above:

	Area (sq. ft)
<i>CULTURAL ACTIVITIES :</i>	
This portion is essential to achieve the goal of creating a Cultural Embassy: the reawakening of the Chinese heriage.	
Studio	11,000
Chinese art courses such as brush painting, calligraphy, sculpture, knitting; a small portion could be rented to artists.	
Galleries	6,500
Chinese art colletion, permanent and temporary	
Classroom	5,000
Courses such as language, art history & theory, Chinese history	
Library & reading rooms	3,000
mainly Chinese history & history of Chinese in America; selected collection of Chinese novels, magazines and newspaper; For future expansion, some offices spaces could be converted into the library	
Tai Chi Room	2,800
for martial arts courses, Chinese dancing & aerobatics	
Bookstores	1,000

Theatre	
Auditorium, 400 seats	3,200
Projectin room	150
Backstage, including dressing rooms, storage, rehearsal rooms, workshops	11,500
Administrative	1,500
Foyer	3,500
Stage, approx. 30 ft deep, 35 ft wide	1,000
Coat room	250
Cooking school	7,000
including demonstration rooms, a library specializing in cooking books, locker rooms for staffs & students, administrative	
Function/seminar rooms	5,000

subtotal	61,000
<i>COMMERCIAL USE:</i>	
This portion is brought in to generate revenue to operate the building	
Offices	
13,000	
Restaurants/snacks	12,000
Lounge/bar	4,500
Retail/shop	6,000
such as Chinese instruments, art works, crafts or furniture	

subtotal	35,500
Subtotal of net functional area	96,500

SUPPORTIVE:

This portion is necessary to make the building animated as well as functional

Indoor seating	7,000
This is incorporated into the "Chinese garden" design concept. People could socialize with friends here	
Washroom	4,500
Each floor should have two locations of washrooms	
Lobbies	
Washington street lobby	2,800
Kneeland street lobby	2,100
West lobby	1,200
Basement facilities	
Mechanical /electrical	1,600
Loading docks	5,000
Storage	8,000
Outdoor garden	9,000
This should be a tranquil & comtemplative place	
Roof garden	1,500
on top of the existing Hayden Building	

Since the Cultural Embassy would be a building of high quality, a low efficiency ratio should be applied to get the estimated gross area

Estimated gross area
= net functional area ÷ Efficiency Ratio
= 96,500 s.f. ÷ 60% = 160,000

Chapter Five:
DESIGN CONCEPTS

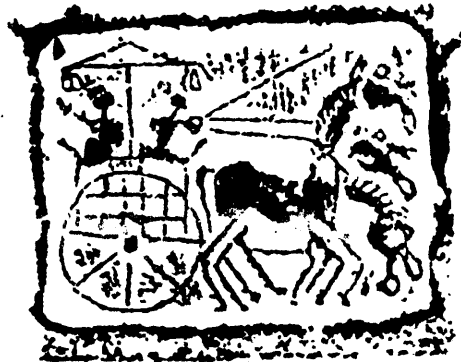

INTRODUCTION

Drawings could be rendered beautifully and models could be built handsomely. However, if the design is poorly done, these presentation would be superficial and meaningless. Every design should have its unique social context, functional requirements and architectural expression. To arrive at a good design solution, many issues have to be considered, many concepts have to be tested, and finally, many decisions have to be made. In this chapter my design concepts are presented.

GENERAL DESCRIPTION

Before the discussion of the design concepts, I would like to give a general introduction to the proposed Cultural Embassy.

The proposed building, situated on a site 320 ft. by 180 ft., has five stories and one service basement. The building height is 74 ft. except at the two "pagoda gateway" entrances which soar up to 102 ft. The net useable area is 96,500 sq. ft. The gross area is estimated to be 160,000 sq. ft. Cast-in-place concrete columns and beams constitute the main structural system. The atrium-lobbies are enclosed by steel spaces frames or trusses.

On the ground floor, there are retail stores, restaurants and an art gallery; the next level includes an auditorium with its foyer, two restaurants, a bar, and seminar/function rooms; cultural activities are housed in the third floor. This includes a Tai Chi Room, a cooking school, a library and a few classrooms. From this level one could find one's way to the outdoor garden. Offices occupy the fourth floor and studios the top floor.

Walking inside the building, one would discover that an outdoor garden, which is surrounded on three sides by the building mass, become the anchoring element for the whole complex.

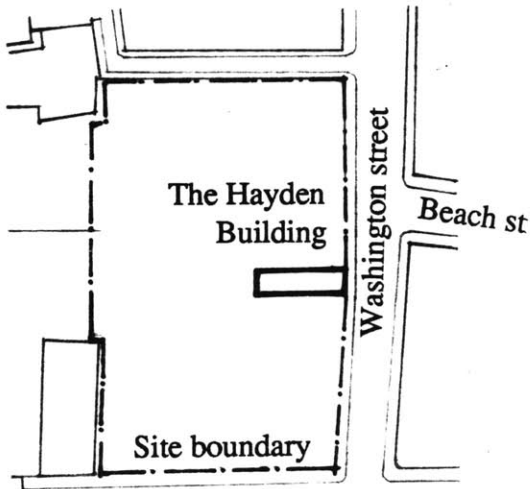

Fig. 5.1
Location of the Hayden Building

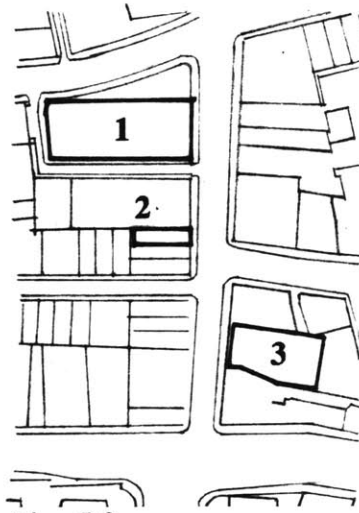

Fig. 5.2
Tendency of expansion of Chinatown into the combat Zone

1. China Trade Centre
2. a Chinese drug store
3. a Chinese movie theatre (Pagoda Cinema)

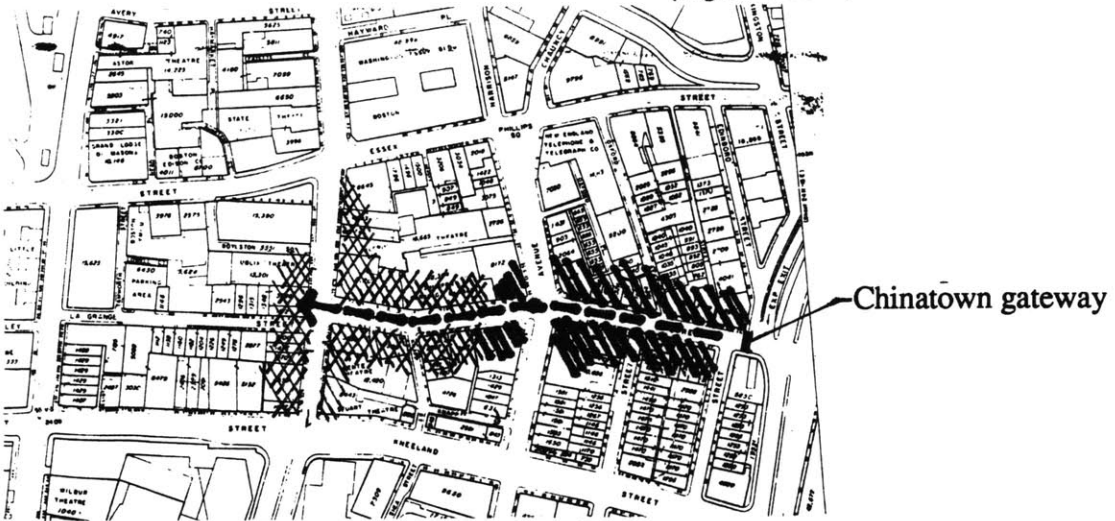





Fig. 5.3
The expansion of the Chinatown Core

-  Existing core of Chinatown
-  Projected extension of Chinatown Core into the proposed site
-  Spine of the Chinatown core

The general building services are located in the basement. This includes loading, storage, mechanical and disposal. There are four service cores coming up from this level to serve the building.

PRESERVATION OF HISTORICAL BUILDINGS

Founded in 1630, Boston is one of the oldest American cities. Coming to Boston, one would expect to see some architecture which is not found in other new cities such as Los Angeles or Miami. The unique architectural character of this city stems from the fact that Boston has retained its physical past while allowing new landmarks to take root. It is important to allow significant buildings to remain, to trace the history of the city. The act of wiping out every single old building would only lead to cutting the continuity of architectural transformation.

Sharing a similar attitude, Boston Landmarks Commission has undertaken a meaningful task to identify historical buildings destined for preservation. Factors considered include the distinctiveness and integrity of the buildings, prominence of the architect, variety of the building style or type, and historical significance of the building to the city, state or nation. The landmarks around or within my proposed site are listed in chapter three: Site Analysis. (Fig. 3.2) All these landmarks are preserved in my design.

The Hayden Building

Among all the historical buildings mentioned, the Hayden Building creates the most difficult design constraints since it is located within the proposed site. (Fig. 5.1) Norberg-Shultz has said that a river is a dividing element but at the same time a unifying element. The river analogy applies to this design problem. Depending on how the architect handles the constraint, he can turn it either into a dividing or unifying element. The Hayden Building, when analysed carefully, can give clues to the design solution. The clues I abstract from this historical building include its height, width, window

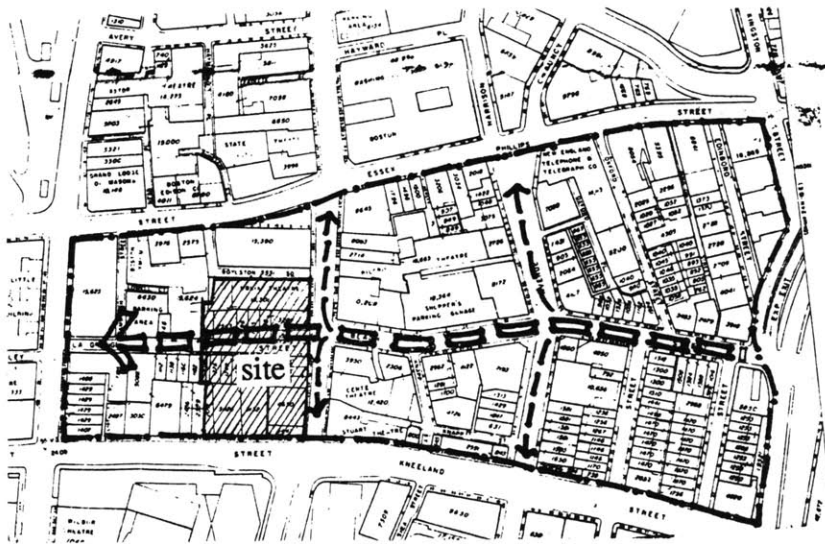

Fig. 5.4
Projected boundary of
the Core of
Chinatown.

- Boundary of the Core of Chinatown
- == Spine of Chinatown
- ← Growth expand laterally

Fig. 5.5
Transportation Building
The link to Boston Place has revitalized the
dead ally into an active area;
The diagonal link becomes an internal
street between Stuart Street and Park Square



Perspective

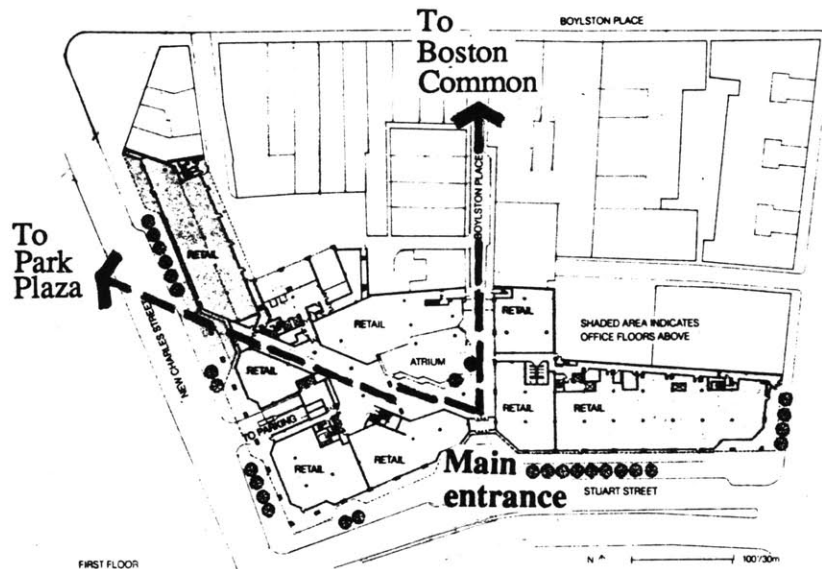

dimension and its object-like nature. These elements will be elaborated in the subparagraph "facade study".

CHINATOWN CORE EXPANSION

The existing Chinatown Core is along Beach Street between Chinatown gateway and Harrison Avenue. Physically, the core can grow neither north, east nor south due to the existence of Lafayette Place, S.E. expressway and New England Medical Centre respectively. To the West is the deteriorating Combat Zone which is slated to disappear eventually. Due to its proximity, it is the ideal and logical area for the extension of Chinatown heart. The existence of the China Trade Centre, a Chinese cinema and a recently opened Chinese drug store in this area shows clearly this tendency. (Fig. 5.2) Therefore, the proposed site will help to extend the heart along Beach Street up to Washington Street, forming a spine from the Chinatown gate to the Cultural Embassy. (Fig. 5. 3)

Projecting into the future, we can assume Chinatown might expand and take over the whole city block defined by Washington Street, Boylston Street, Stuart Street and Tremont Street. Also, growth can expand laterally off Beach Street and Harrison Ave. (Fig 5. 4)

TALKING TO THE CONTEXT

Public Movement

The result of responding to a social context in terms of public movement has always proved to be successful. The Transportation building in the next block demonstrates this issue strongly. (Fig. 5.5) With its ground floor retail stores and three public entries, Transportation Building has revitalized the neighborhood and created more street-level activity. The main entrance is on Stuart Street, which is connected to the alley Boylston Place through a second entrance. Besides providing a shortcut for people walking between the theatre district and the Boston Common; this link has also made the dead alley into an active area. The third entrance is on

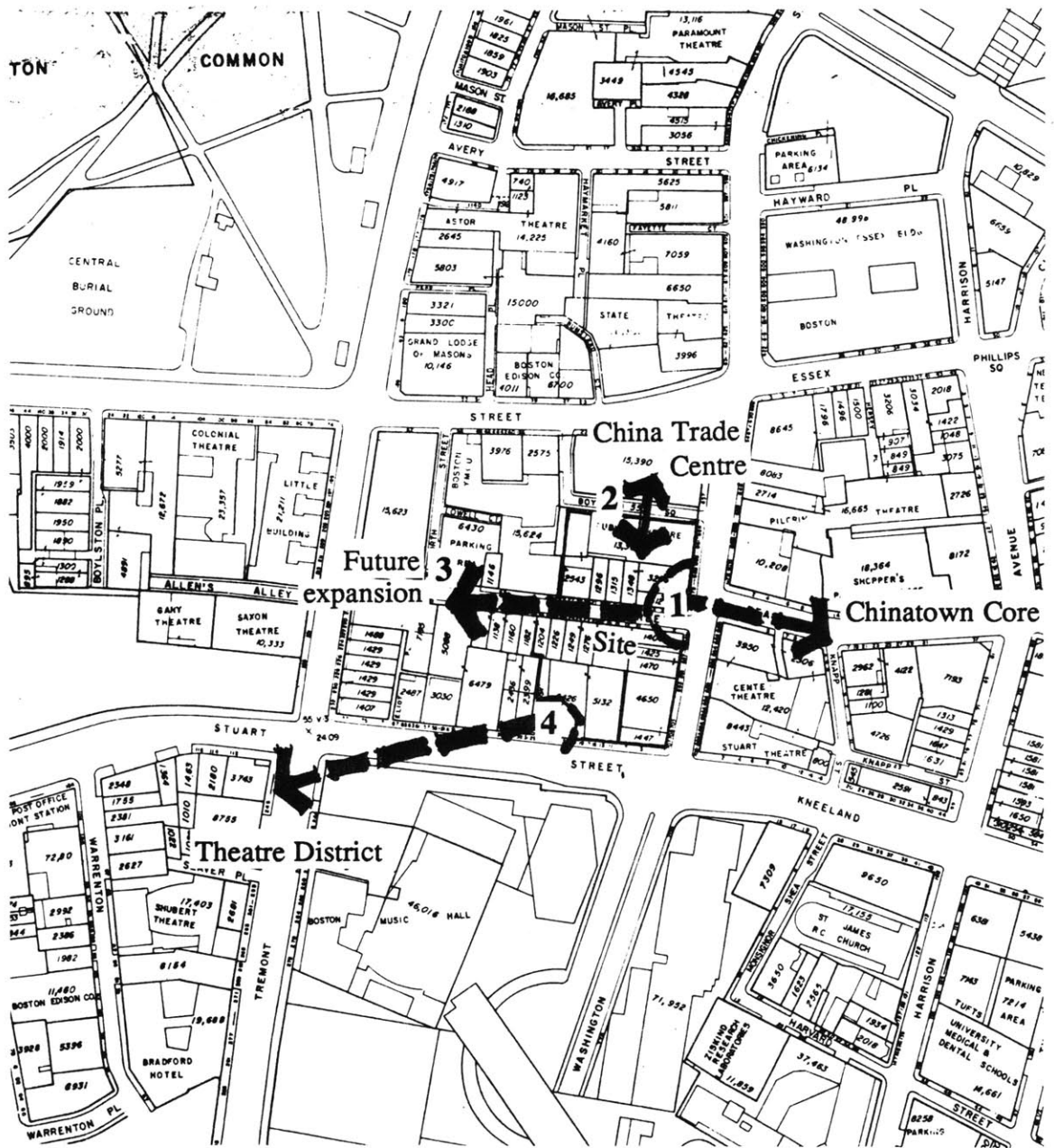

Fig. 5.6

Talking to the context

- 1 a main entrance addressing the Core of Chinatown
- 2 a link to Chinatrade Centre
- 3 provide continuity through the proposed building from Beach Street to the rest of the block
- 4 an entrance addressing the Theatre District

New Charles Street which finds its way diagonally to the main entrance. This diagonal movement has become an internal street for people walking between Stuart Street and Park square.

Similar to Transportation Building, my proposed Cultural Embassy talks to the context. The most important context which it needs to deal with is the continuity of the Chinatown Core. Since Beach Street terminates on Washington Street, when standing at the bend of Beach Street, one will see part of the proposed site framed by the buildings on two sides of Beach Street. This particular portion of the proposed building has a direct association with Chinatown as well as with Beach Street. The main entrance into the proposed building should be located in this dominant position. This entrance could be a very welcoming gesture to receive Chinatown. (Fig. 5.6)

Located to the north of the proposed building, China Trade Centre has been renovated into an atrium-type retail center in the first three levels and offices on top levels. If a link could be provided between China Trade Centre and the proposed Cultural Embassy, the continuity of public space would be reinforced. (Fig. 5.6)

Under the subparagraph "Chinatown Core Expansion", an assumption has been made that Chinatown core will eventually occupy the rest of the block. In order not to make the proposed building block the Chinatown Core expansion, a penetration is necessary for providing continuity through the building from Beach Street into the rest of the block. (Fig. 5.6)

The connection of the Theatre District with the Cultural Embassy to the Chinatown core is critical. With twenty active theatres, the theatrical history of Boston was glorious during the 1930's. Unfortunately, the theatre district has fallen into parts since the 1970's. Among the active theatres are Wang Centre, Shurbert theatre and Wilbur theatre. which are located around the intersection of Stuart Street and Tremont Street. It will be logical to have an entrance into the proposed Cultural Embassy on Kneeland Street to

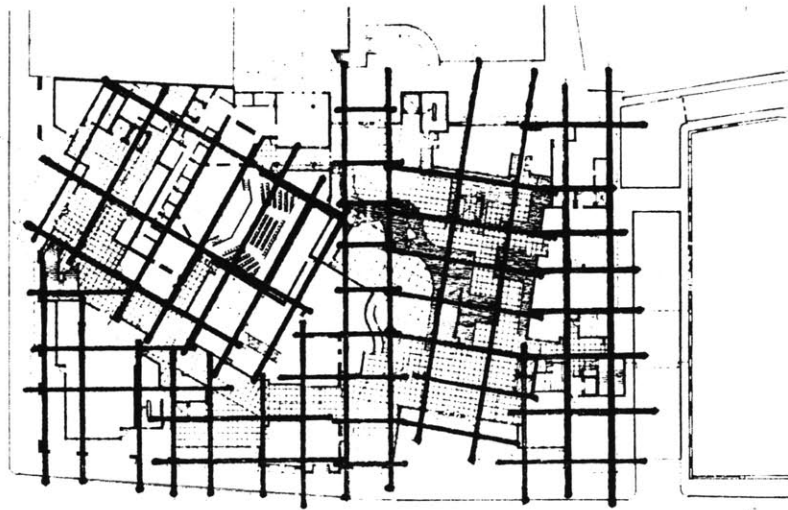
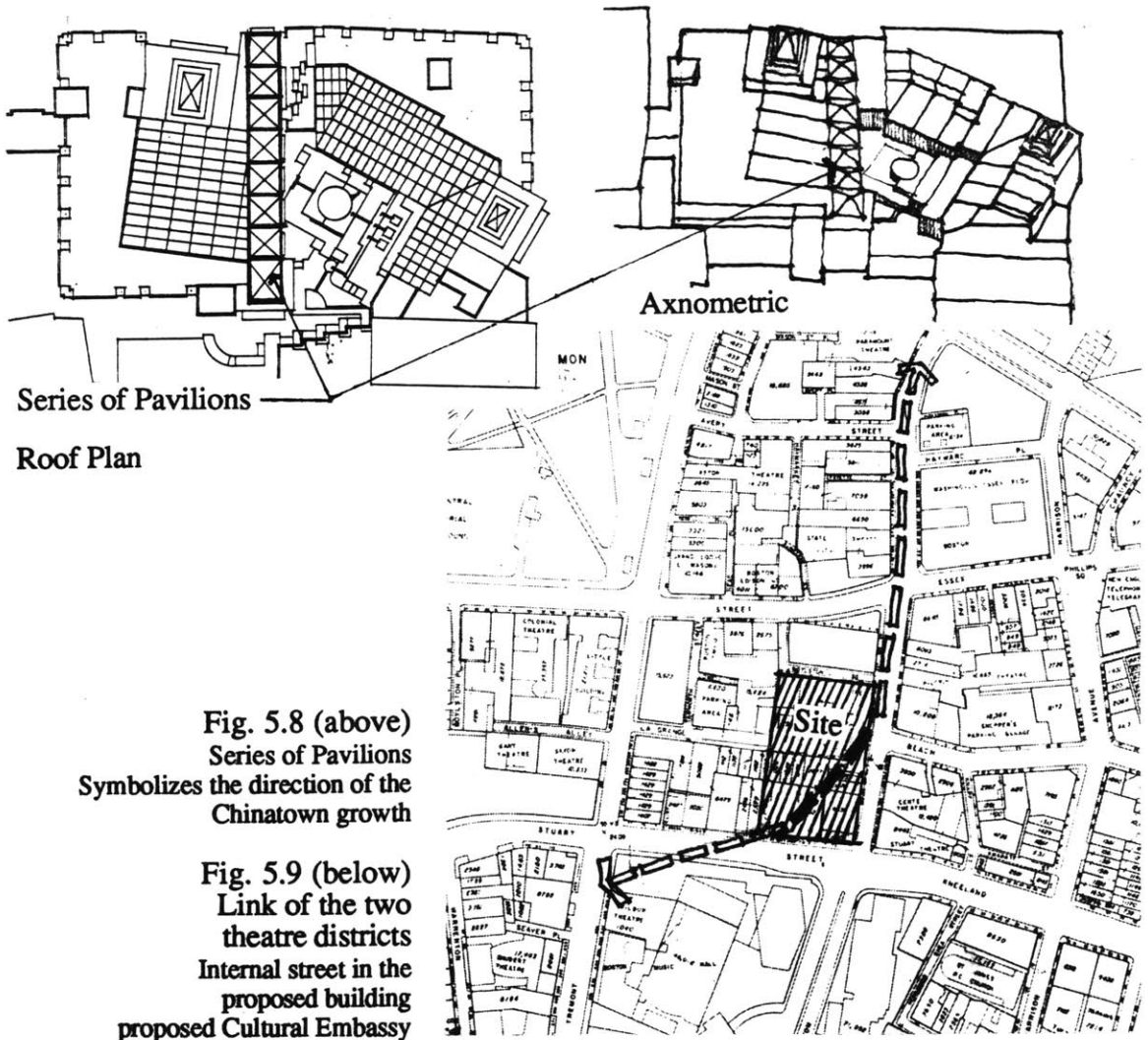

Fig. 5.7
 Principle of three grids
 major grid: orthogonal
 to city block
 second grid: responds to
 Beach street
 third grid: responds to the
 theatre district



Series of Pavilions
 Roof Plan

Axonometric

Fig. 5.8 (above)
 Series of Pavilions
 Symbolizes the direction of the
 Chinatown growth

Fig. 5.9 (below)
 Link of the two
 theatre districts
 Internal street in the
 proposed building
 proposed Cultural Embassy

address this part of the theatre district, which is only half a block from my proposed site. (Fig. 5.6)

Principle of Three Grids

In my proposed building, there are three grid systems derived from the context: (Fig.5.7)

The major grid responds to the city block which is orthogonal to Washington Street and Kneeland Street. This grid penetrates the proposed building from east to west in a linear form, supporting a series of seven pavilions on the top. (Fig. 5.8) This symbolizes the direction of the Chinatown core growth in the future.

The second grid system is suggested by the angle created by Beach Street meeting Washington Street. This grid can provide a main entrance facing directly to Beach Street, so that one will see the entrance without distortion.

The third grid system is created through the notion of having an entrance addressing the Theatre District. By a shift of 30 degrees, this grid system helps to generate the auditorium configuration and the diagonal internal path movement. The latter element in turn works closely with the internal movement metaphor which will be discussed under the subparagraph "metaphors". Also, this diagonal internal movement becomes an internal street linking the Theatre District at the Stuart-Tremont block and the Theatre District further north along Wahington Street. (Fig. 5.9)

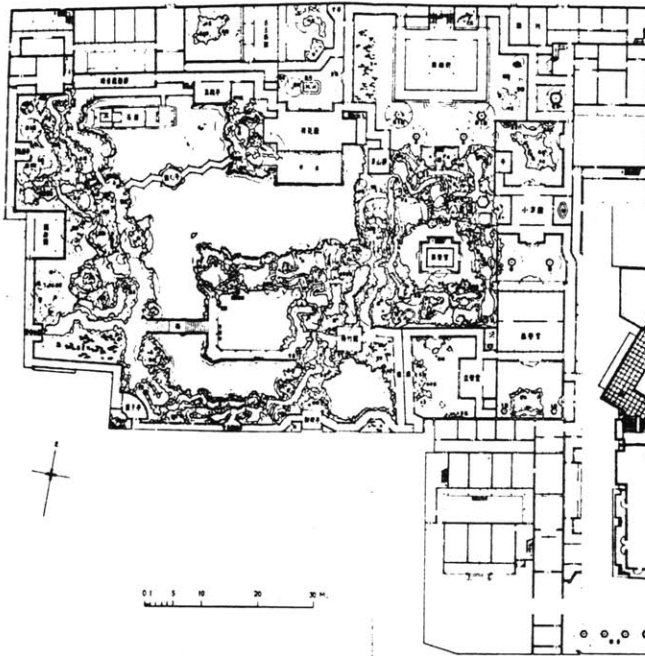
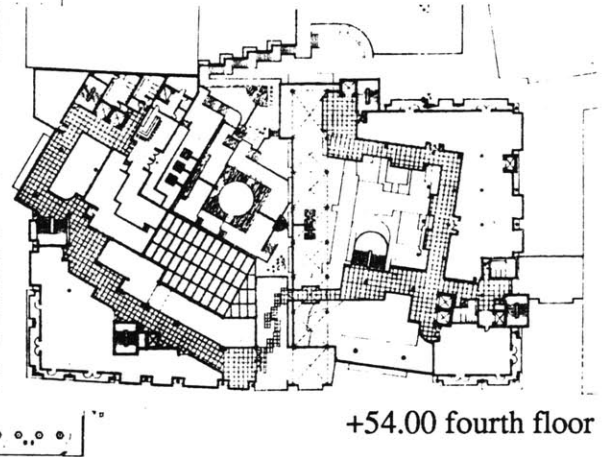
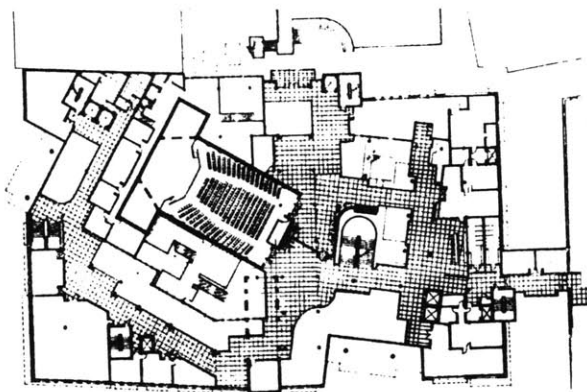

Fig. 5.10 (left)
See Chi garden, Zoochow
An example of Zoochow garden



+54.00 fourth floor



+18.00 first floor

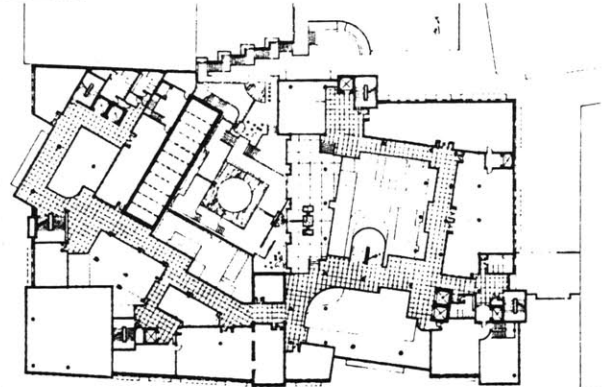

+42.00 third floor

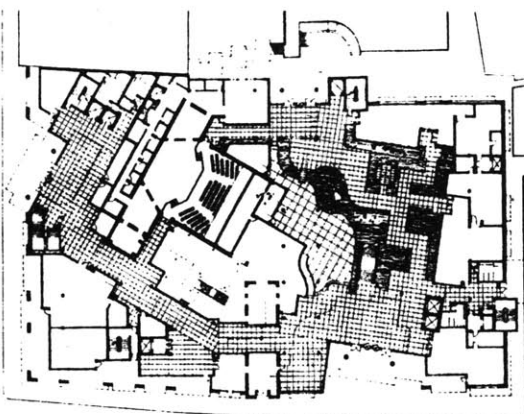

+0.00 ground floor

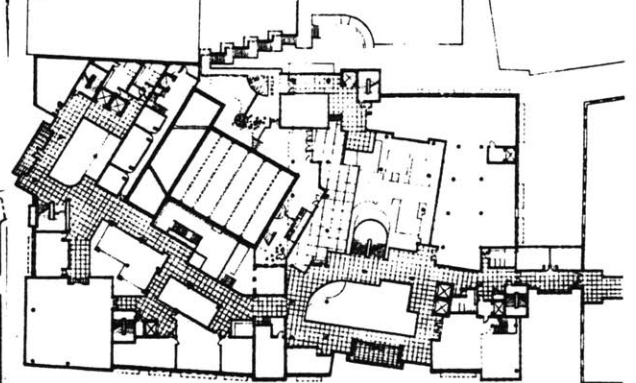

+30.00 second floor

Fig. 5.11
"Garden Path" in the proposed building
The grided circulation is the "garden path"

METAPHORS

There are two metaphors in the design: the metaphor of "*Chinese Garden*" is applied to the building interior and the metaphor of "*Ancient Chinese walled City*" is applied to the building envelope. Metaphorically, the "*city walls*" enclose a human-built environment which itself is a transformed "*garden*" bisected by "*garden paths*".

Metaphor of Chinese Garden

Garden Path

In a Chinese garden, there are two kinds of viewings: "*in-position viewing*" and "*in-motion viewing*". Chen Congzhou, the foremost authority on Chinese gardens, says that this must be the first and most important consideration in the design of a garden.

In-position viewing refers to "lingering observation from fixed angles". It concerns a set view from a set position, either as framed vistas or lines of sight between the viewer and distant elements. In-motion viewing refers to a longer "touring" vista. It concerns the progression of visitors through the landscape and calls for changing scenes with each bend or rise in the path.

This Chinese landscaping principle has created many great gardens, notably the famous Zuochow gardens. (Fig. 5.10) The surprising variations in these gardens contrast strongly with the rigidity of the traditional Chinese building layout. The same viewing concept could be appropriately applied to the interiors of modern buildings. This would result in giving more intriguing spatial experience to people.

In the proposed Cultural Embassy, the in-position viewings occur at many rest spots along the path and at some sitting areas where viewers may stop to take in the scene in greater detail. The in-motion viewing is developed throughout the whole building. The path is consistently changing angles, enabling viewers to see different views from time to time. The change of views make people enjoy the walk inside the building. (Fig. 5.11)

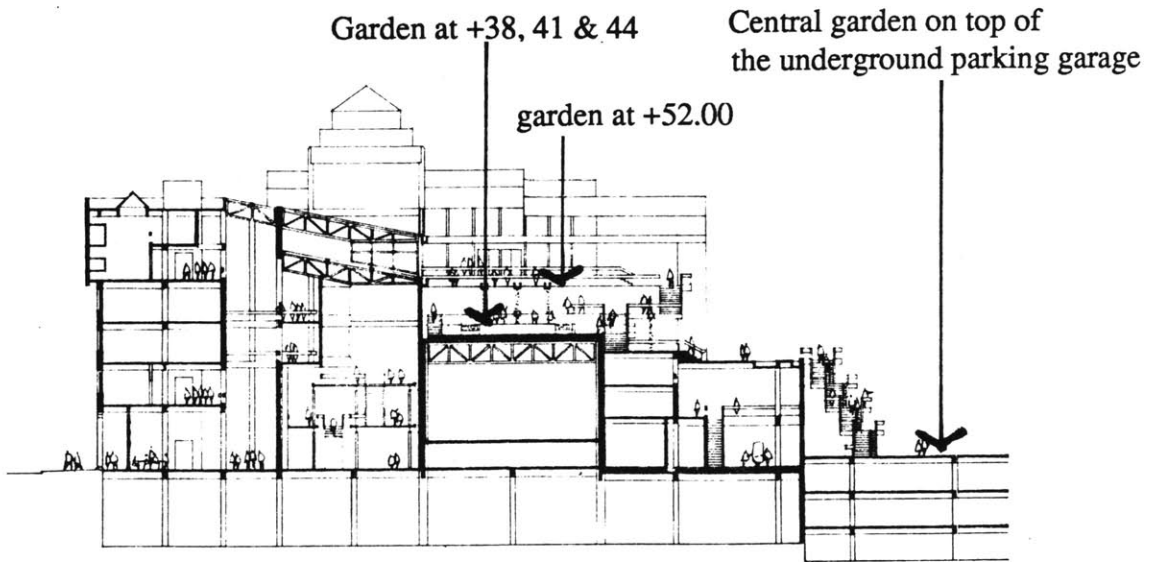

Fig. 5.12
This section shows the spatial flow of the series of gardens.

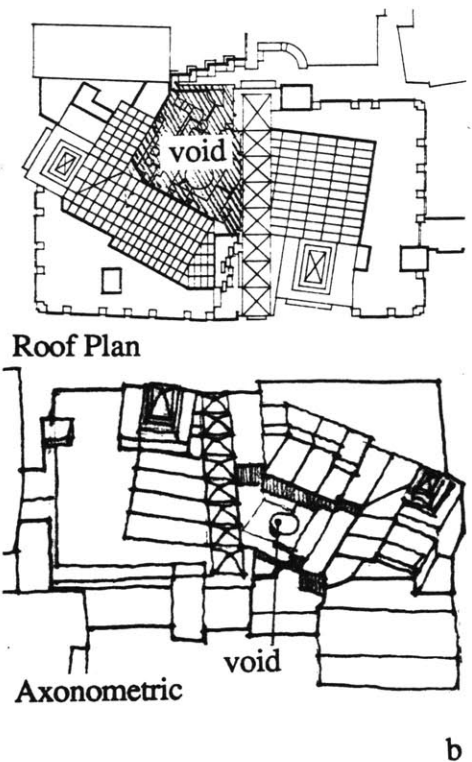
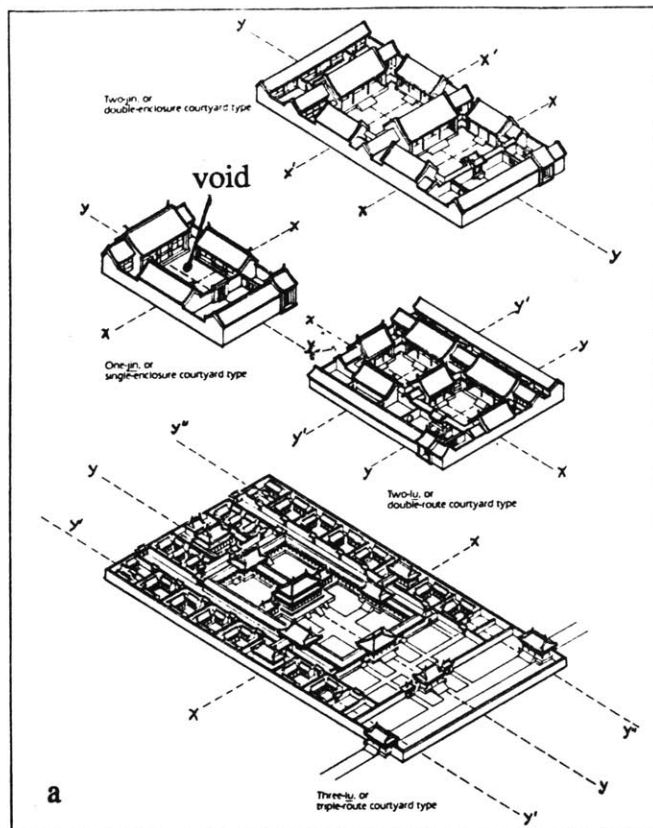

Fig. 5.13
Void as the anchoring element
a. Traditional Chinese courtyard house, plan, axonometric
b. The proposed cultural embassy

Gardens Within Gardens

In Chinese gardens, "*Gardens Within Gardens*" and "*Small Gardens Wrapped by large Gardens*" concepts always make the place full of surprises. In the Cultural Centre, the whole building can be treated as a big garden. Within this big garden there are small gardens. The garden paths lead people horizontally and vertically through the spaces. Eventually, one finds one's way to an outdoor garden which is enclosed on three sides. This outdoor garden is not the terminating point yet: it brings people up to another garden on a higher level, it also brings people down to a smaller garden at a lower level, and again down to a larger garden which is built on the rooftop of a proposed underground parking garage. The stairway leading down to this garage rooftop garden is transformed from the Chinese garden's "*nine-bends bridge*". This series of gardens strongly suggests the continuity of spatial flow. (Fig. 5.12) In traditional Chinese building layout, an outdoor courtyard always occupies the centre of the complex. (Fig. 5.13a) The proposed Cultural Embassy shares the same spatial definition: the central outdoor garden, being a void, becomes the anchoring element of the whole complex. (Fig. 5.13b)

The outdoor garden is a protected and tranquil space. Protected because it is "sunken" with glazing on three sides; the wind cannot invade this space. Tranquil because of the peaceful setting, with the pacifying sound of water-flow infiltrating the air. Without any apparent trace of a Zoochow garden, this garden captures the spirit of a Chinese garden in a contemporary way: the application of water, the symbolic use of square and round geometry, and the display of contemporary Chinese sculpture.

Water

Water is always a crucial element in landscape as well as "*fung-shiu*" which is the art of "adjusting the features of the cultural landscape so as to minimize adverse influences and derive maximum advantage from favourable conjunctions of form." In landscape, water makes the place alive. In "*fung-shiu*", water symbolizes

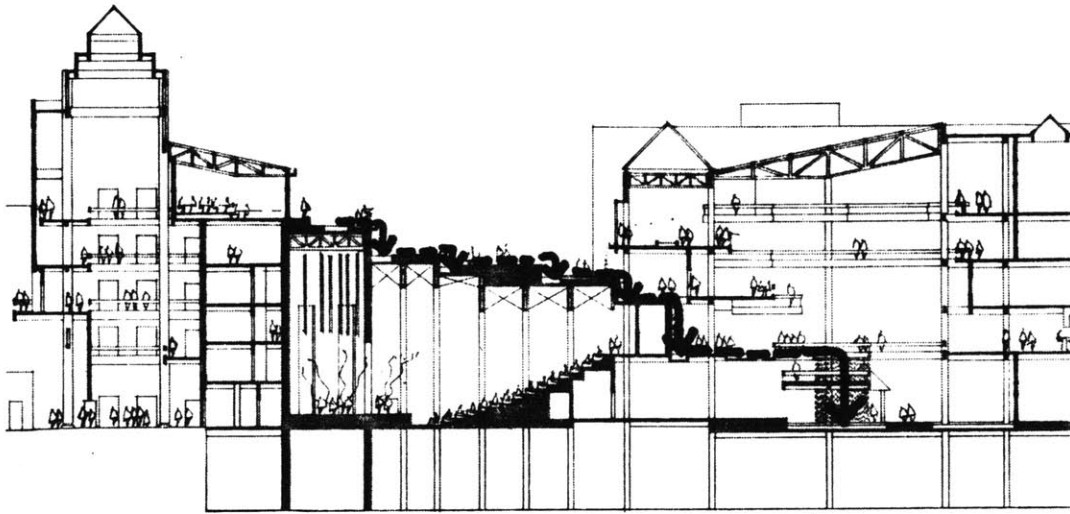

North-south section AA

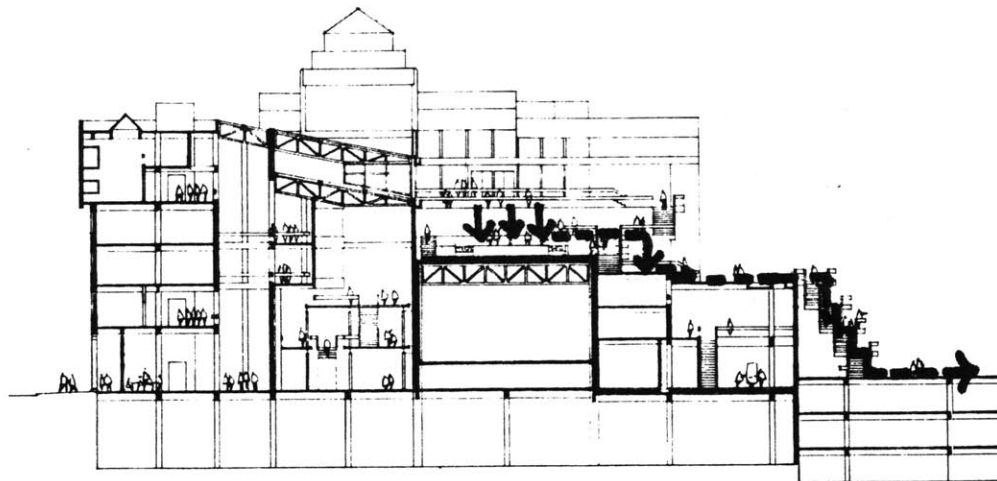

East-West section CC

Fig. 5.14
Water flow

The water flow strongly suggests the continuity of spatial flow

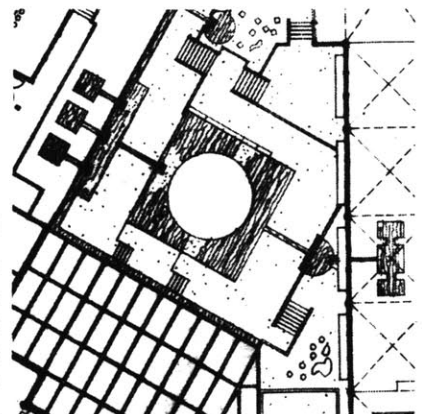

Fig. 5.15
Outdoor garden
The concept of "Round Heaven,
Square Earth" is applied to the
outdoor garden in which the main
components are a round platform
surrounded by a square pool.

auspiciousness; application of water in a place signifies a good future for the users, especially for the owners. Also, there is an old Chinese saying: "*one has to think of the source of the water when one drinks it*". This implies one has to remember one's own roots. The source of the water in the garden sequence begins in the highest "garden" which is on the rooftop of the auditorium stage. The water, by the natural force of gravity, finds its way down to every floor, eventually to the "garden" in the ground floor and also to the central garden on top of an underground parking garage. (Fig. 5.14) Again, the continuity of space is strongly suggested by the water flow.

Round Heaven, Square Earth

The ancient Chinese believed that the Earth they stood on was square in shape, and the Heaven on top was round: *the square Earth was perceived to be enclosed by the round Heaven*. This concept is clearly demonstrated in The Altar of Heaven, Beijing. (Fig. 5.16)

In designing the outdoor garden, I have applied this ancient orthodoxy as the controlling principle of geometric elements. The main component in the garden is very simple: a round platform surrounded by a square pool. (Fig. 5.15) Standing on the platform, which is accessible by a few pieces of flat stone, one feels one is detached from the surroundings and closer to the heaven above. Water is an element of the Earth, a pool of water around the platform symbolizes the Earth. I have applied the same "Square Earth-Round Heaven" principle in the design of the entrance gateways as well as ornamental precast concrete panels. These will be covered in later paragraphs.

Sculpture

Sculpture is an essential element in a successful open space. It can be a focus of interest. It can be an interpretator suggesting meaning of the space by the way in which it is displayed. It can also be simply a cultural expression. The sculptures in the outdoor garden encompass all these adhibitions. The style of the sculptural expression is another important touch in creating a garden of

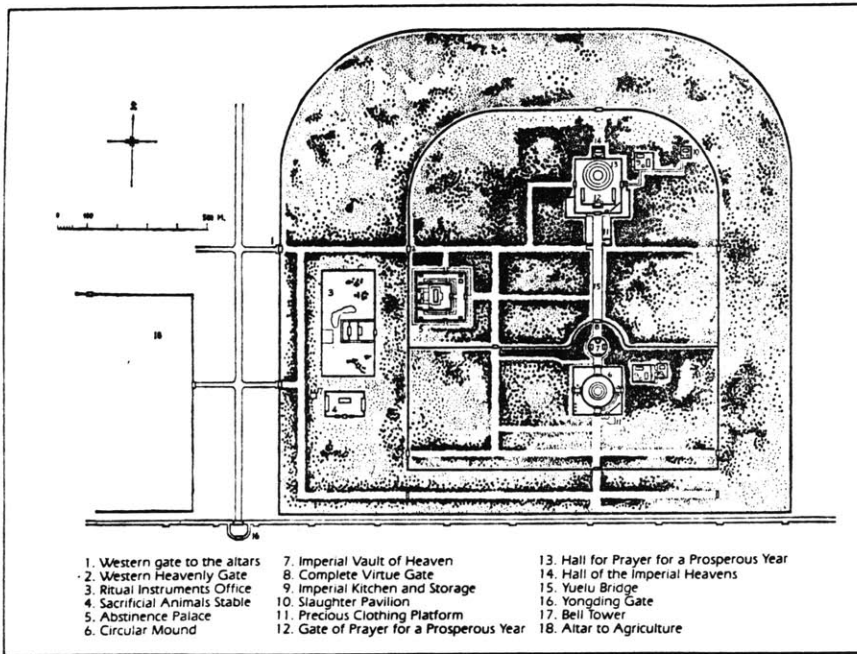
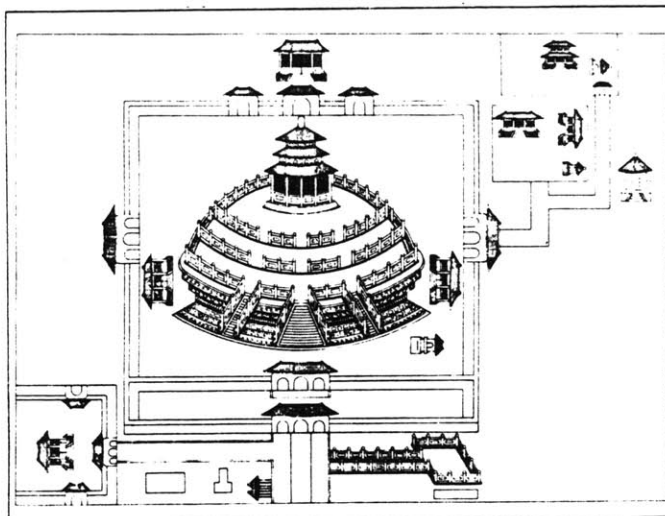
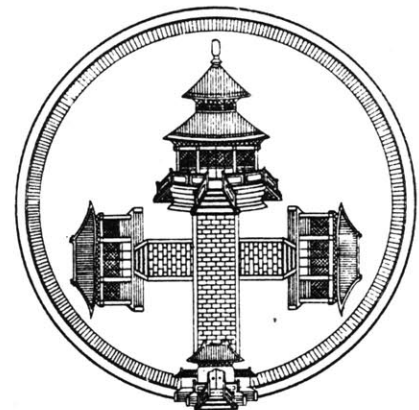

Fig. 5.16
The Altar of Heaven, Beijing.
The "Round Heaven . Square Earth" concept as reflected in Circular Mound Great Sacrific Hall.

Plan of Altar of Heaven Complex



Great Sacrifice Hall



Imperial Vault of Heaven

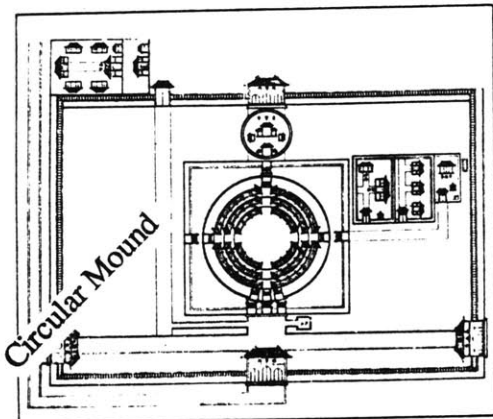

Circular Mound

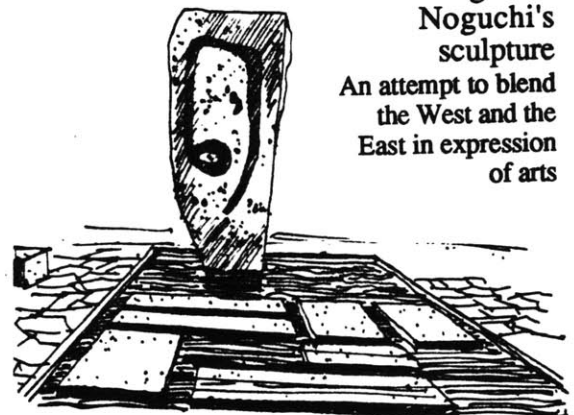

Fig.5.17
Noguchi's sculpture
An attempt to blend the West and the East in expression of arts

appropriate atmosphere. Instead of reproducing a typical Zoonchow garden here, I have transformed it into a contemporary Chinese garden. Logically, sculpture creatively transformed from old forms should be incorporated into the garden. The Japanese sculptor Noguchi's attempt to blend the West and the East in his work is the direction contemporary Chinese sculpture should follow. (Fig. 5.17)

Borrowing View

"*Borrowing view*" is another ingenious concept in Chinese garden design. The garden designer would carefully "borrow" and "bring in" elements such as distant mountains and pagodas outside the physical boundary of the garden to be part of the garden scenery. In my proposed building, the physical boundary of the outdoor garden is defined on three sides by the building mass. Standing in the garden, besides seeing the series of pavilions as "adjacent view", one will also see the south facing and east facing entrance pagodas as "distant view" from a distance. These pagodas have been "borrowed" into the garden design. (Fig. 5.18)

Metaphor of Ancient Chinese Walled City

There are three categories of ancient Chinese cities: the capitals were built upon cosmic concepts, the walled cities were constructed for defensive motives and the trading cities were developed for economic purposes. The walled city is used as a metaphor in developing my building envelope.

Originally, the Chinese, after selecting the site, built the walls for the city before the city itself. The sole purpose for doing that was defense against warriors who had the ambition to aggrandize their powers or other tribes who always sought to invade the fertile land of China. Most cities were surrounded by a single wall and each side of it was provided with at least one gate. (Fig. 5.19) This defensive motive generated the walled cities which appeared all

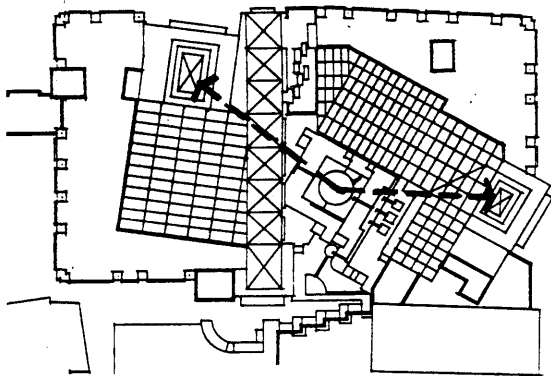

Roof Plan

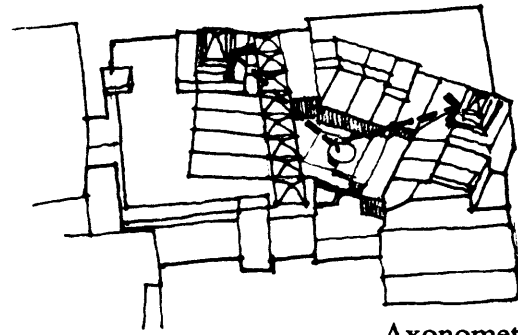

Axonometric

Fig. 5.18
Borrowing View

The two pagadas are being borrowed as "distant view" into the garden

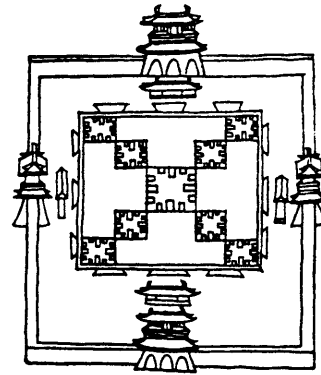
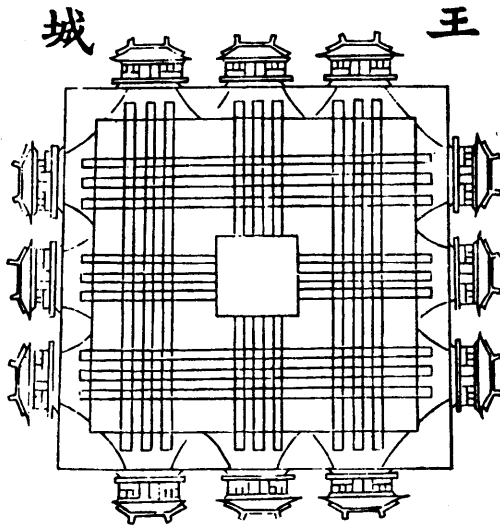
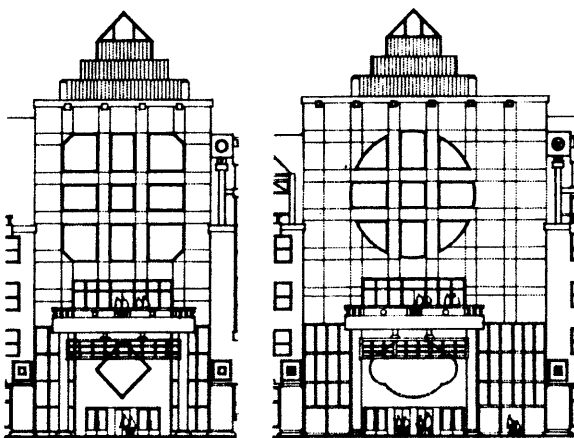

Fig. 5.19
Chinese ancient walled city



South Elevation

East elevation

Fig. 5.20
Pagoda gateway

1. Entrance facing Chinatown, the window opening shapes are transformed from round form.

2. Entrance addressing the theatre district, the window opening shapes are transformed from square form.

through the Chinese history until the early twentieth century upon the advent of the combat planes.

It is obvious that the "City walls" of the proposed building are not for military defensive purpose in this new age. But metaphorically, the city walls protect the property inside the building from vandalism; they set the demarcation between the inside and the outside world. The notion of "city walls" is reinforced by having a "city gateway" on each side of the building.: the east gateway welcoming Chinatown, the south linking to the Theatre District, the west opening up into the proposed big garden in the centre of the city block, and the north gateway physically bridging to the existing China Trade Centre. Among these four gateways, the ones on Washington Street and Kneeland Street are more open to the public. In order to make them look more important and at the same time have some Chinese touch, a transformed pagoda has been superimposed on the city gateway to become a "pagoda gateway". (Fig. 5-20)

The geometry of the window openings on these two "pagoda gateways" echo back to the "round heaven, square earth" concept. The Washington Street pagoda gateway, facing Chinatown, is relatively more important conceptually than the one on Kneeland which addresses the Theatre District. The window openings on the former are transformed from the round form, symbolizing Chinatown as the "heaven". (Fig. 5.20) On the other hand, the window openings on the latter are transformed from the square form, symbolizing that the theatres are activities on "earth". (Fig. 5.20)

Again, the "round heavn, square earth" concept is applied in the body of the "city wall". Square precast concrete panels are used near the the earth while round ones are installed on the top edge of the wall, reaching out to the sky. (Fig. 5.21) Each square concrete panel has an animal engraved on it, and the animal symbolizes orientation: ginglong (green dragon) synmbolizes east, bailu (white tiger) south,

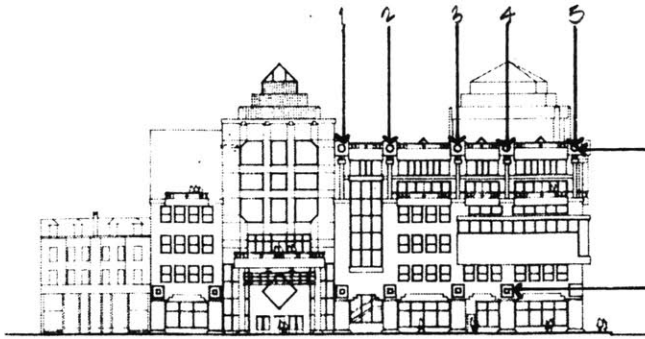

Fig.5.21
 "Round Heaven, Square Earth" concept applied to the facade.
 Round forms are reaching out to the sky. Square forms are near the earth.

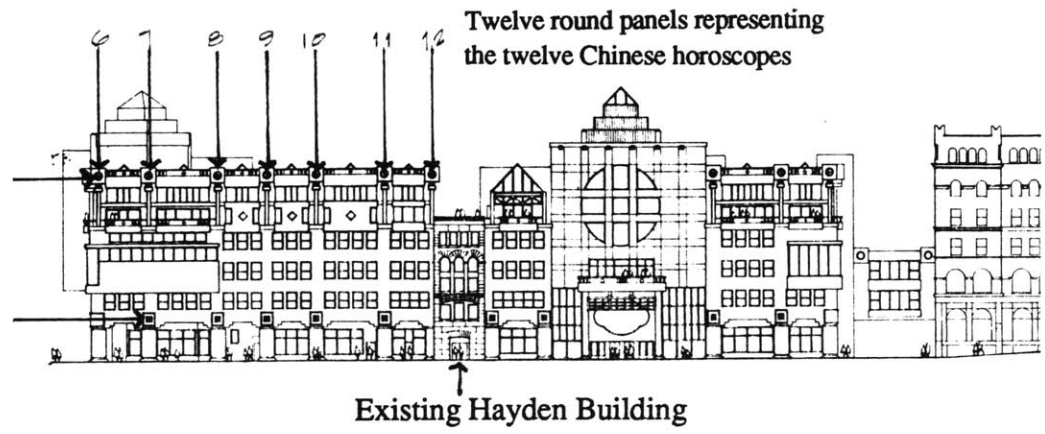
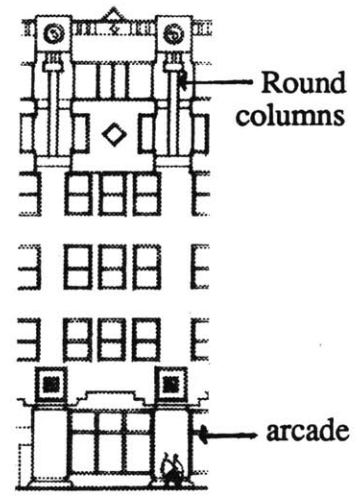
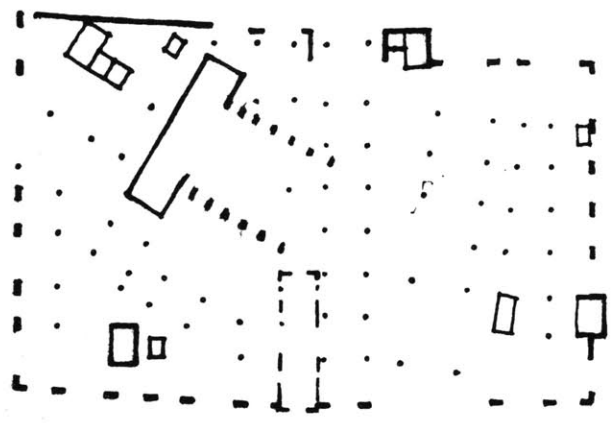

Fig. 5.22 (below)
 Thick city wall at periphery & free standing column in the interior.

Fig. 5.23 (right)
 Arcaded ground floor is transformed into round columns with elements reminiscent of capital & tou-kung.



Zhuque (scarlet bird) west and xuanwu (Tortoise and snake) north. This animal-orientation concept comes from the tile used in Han Dynasty in 206 A.D. (Fig. 5.24) On the other hand, the animals engraved in the round forms have another meaning: they represent the twelve Chinese horoscopes. There are exactly twelve round panels for this symbolic ornamentation at the building corner. (Fig. 5.21)

The walls of the ancient walled cities were always thick and without openings. If this notion is taken literally, there would not be any windows in the proposed building. Again, transformation of old elements into new forms is taking place by abstracting the ancient city walls into my new city walls. Ancient city walls were solid for preventing the invader from getting in, and on the contrary, the transformed "city walls" are punctured with openings to bring in natural light, fresh air and views. This parallelism demonstrates how a transformed element or system fulfills the new requirement.

This "walled city" metaphor induces the differentiation of the structural system along the building periphery from the system in the interior. The notion of the ancient thick city walls is still kept: the periphery is constructed with thick load bearing walls, and the interior is composed of free standing columns. (Fig. 5.22) The thick "city wall" is arcaded in the ground floor and transformed into round columns on the fifth floor. These round column are capped by some elements which remind people of the capital and tau-kung. (Fig. 5.23)

FACADE STUDY

The facade of a building is the "face" associated with the outside world. Under normal circumstances, people see it before entering the building. The impression people get from the building "face" is an important factor in shaping their reactions. This implies that the design of building facades should never be overlooked.



Green dragon (qinglong)



Scarlet bird (zhuque)



White tiger (baibu)



Tortoise and snake (xuanwu)

Fig. 5.24

Hans bricks and tiles

Han tile-ends are all circular with character, icons of animals, plants and other pattern as ornament. Sometimes the location for the tile's use is indicated by the ornamentation. For instance, qinglong (green dragon) represents east; baihu (white tiger), west; zhuque (scarlet bird), south; and xuanwu (tortoise and snake), north.

The Hayden Building, the historical building within the site, gives clues for the facade development. First of all, its *building width* generates the dimension of 20 ft. for the width of certain bays in the proposed building. Together with another dimension of 28 ft., they are arranged to give rhythm to the building. (Fig. 5.25) The *height* of the Hayden building becomes the transition line between the main body and the top part of the facade. (Fig. 5.25) The *width of the windows* becomes the rule for most windows in the new building. (Fig. 5.25) The *object-like nature* of the Hayden Building gives hints at project some spaces out, so as to generate a facade with variation and therefore better composition. The projected spaces are the double-column Tai Chi Room, the library, the studio work spaces clerestories and balconies.(Fig. 5. 26)

Under the paragraph "Metaphor of Ancient Chinese Walled City," I have discussed the symbolism of the "city wall", the "pagoda gateway" entrances, and the "round heaven, square earth" elements of the pagada gateways and the wall. All these are the symbolic elements which make the facade as well as the whole building more meaningful. (Fig. 5. 20, 21 & 22)

However, in the process of designing facades with symbolic elements, there is a tendency to neglect the comfort for the user. In other words, many architects design buildings with dishonest facades: the functional spaces behind the "face" are not harmonious with the exterior. For example, Fumihiko Maki, in designing "The Spiral" in Tokyo, has "adopted from the context the themes of street facade and fragmented building volume, drawing them into a composition involves spirals: a spiral of building volume up to a central penthouse; a flattened spiral of stairways zigzagging up the facade; and a deeper spiral that loops up through the interior." The outcome of this "spiral" concept is a building with an exciting, well articulated facade. However, when one carefully analyzes the design, one would find out that many interior spaces which should be provided with windows looking onto the street are blocked from the outside world. (Fig. 5.27) Why is it so? The opportunity for



Fig. 5.25
 Facade composition
 The width, the height and the width of the window the Hayden Building become the new building facade composition rules.

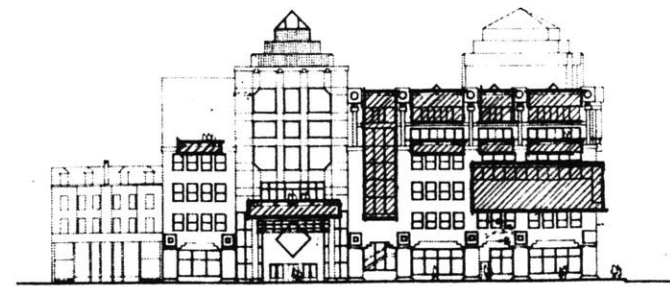
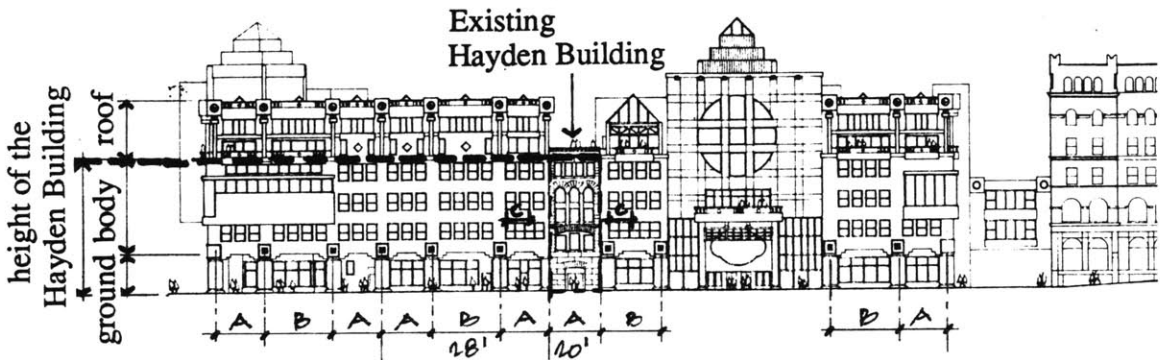
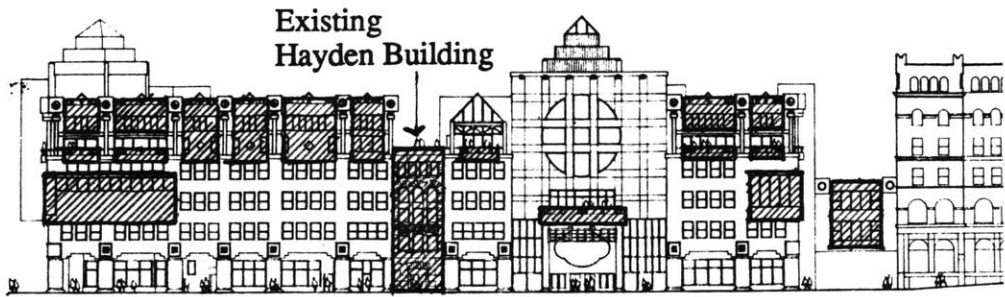

Fig. 5.26
 Object-like element
 Elements projecting out to reflect the object-like nature of the Hayden Building.



bringing in natural light and looking out are sacrificed by the architect in pursuing his "spiral" concept.

This kind of wrong architecture is repeatedly done, especially under the trend of "post-modernism". In order not to commit the same mistake, I have considered to the user while bringing symbolic elements to the proposed Cultural Embassy.

CHINESENESS

The visual outcome of applying the Chinese architectural language to the design is a Cultural Embassy with an exhilarating Chinese identity. Some of the components which bring out the "Chineseness" have been discussed in the previous paragraphs, but for the sake of clarity, I would like to group all the "Chineseness" elements I have applied in the design in this section.

The two metaphors, the "Chinese Garden" and the "Ancient Chinese Walled City", are the more spiritual and conceptual guide for the whole design. They embody the symbolic meaning of cultural forms specific to Chineseness. Under the metaphor of "Chinese Garden", there are a number of concepts: the "In-Motion and In-Position Viewing", "Garden Path", "Gardens Within Gardens", "Borrowing Views", the application of water in "Fung Shui" principle, and the "Series of Pavilions". For the metaphor of "Walled City", there are "Pagoda Gateway" and the nature of thick city wall.

The ancient Chinese orthodoxy of "Round Heaven, Square Earth" is used as the controlling principle of the geometric elements in the outdoor garden, the "pagoda gateway" entrances and the precast concrete panels on the facade. Animals with specific symbols are engraved on the concrete panels. The screens used all along the history of the Chinese architecture are employed in designing partitions.

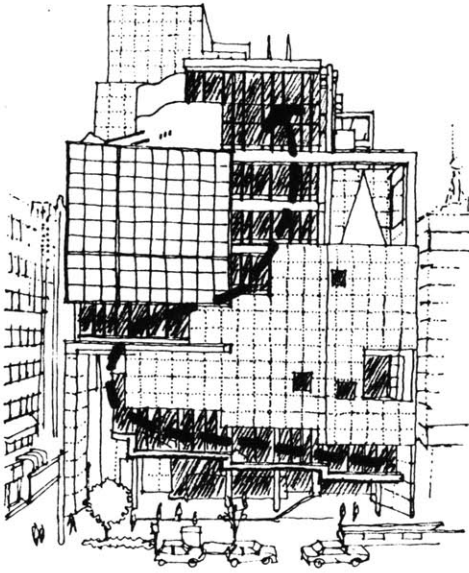

Front facade

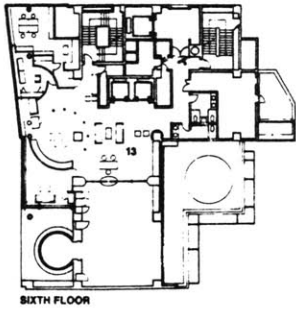

SIXTH FLOOR

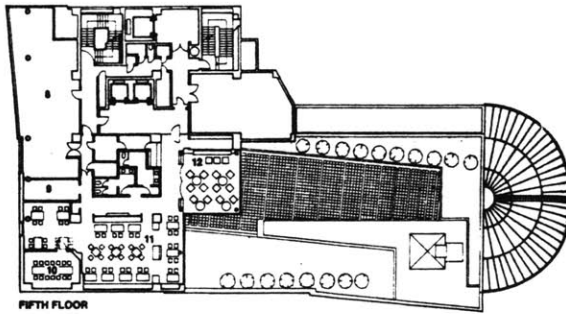

FIFTH FLOOR

Floor plans

Fig. 5.27
 The spiral, Tokyo, Japan
 by Fumihiko Maki
 A building with a exciting well articulated facade
 The dash line indicates the spiral movement up to the penthouse.
 The architect, in pursuring the "spiral" concept, has made many interior spaces cut off from natural light.

TECHNOLOGY AND CULTURE

As discussed in previous chapters, new construction techniques are needed to meet the requirements of new types of buildings and buildings should reflect the technology of their time.

The proposed Cultural Embassy has discarded all the traditional Chinese construction systems such as the tou-kung system and curved lofty roofs. Current technology has been brought in to serve this complex building. For examples, the spacious atrium probably requires a computer to determine dimensional accuracy and structural analysis; the auditorium requires acoustical expertise to provide the best sound conditions and insulation; the application of water requires advanced waterproofing materials and skilful craftsmanship.

The expression of current technology and a unique Chinese identity could be traced in the proposed building. These technological and Chinese elements become the cultural vocabularies of the Chinese architectural language.

Chapter Six:
DESIGN PRESENTATION



Fig. 6.1
MODEL PHOTO
The proposed Cultural Embassy would help to extend the core of Chinatown along Beach Street up to Washington street, forming a spine from the Chinatown gateway to the building.
Note that the "pagoda gateway" entrance is adjusted to face Beach street directly.

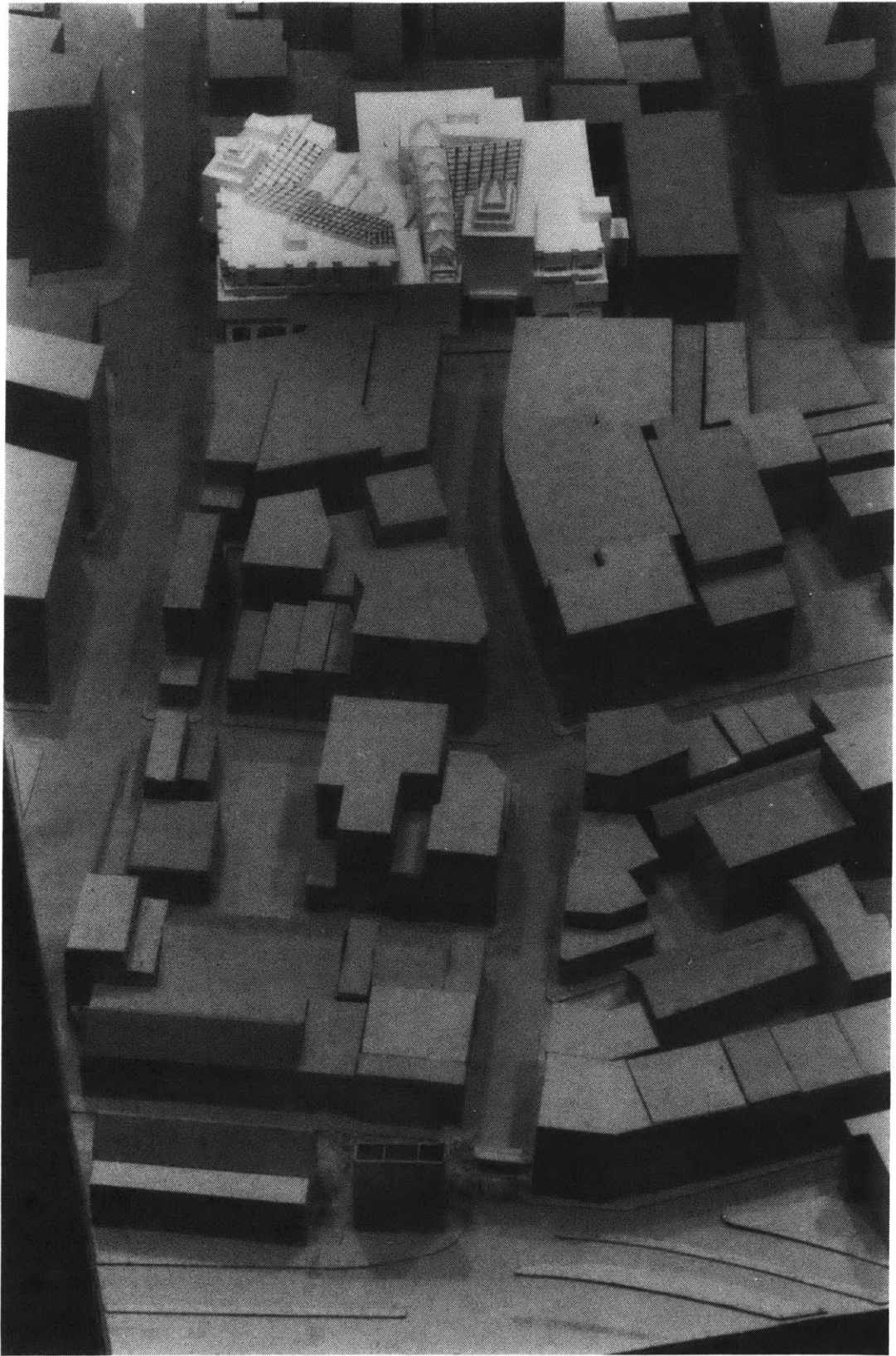
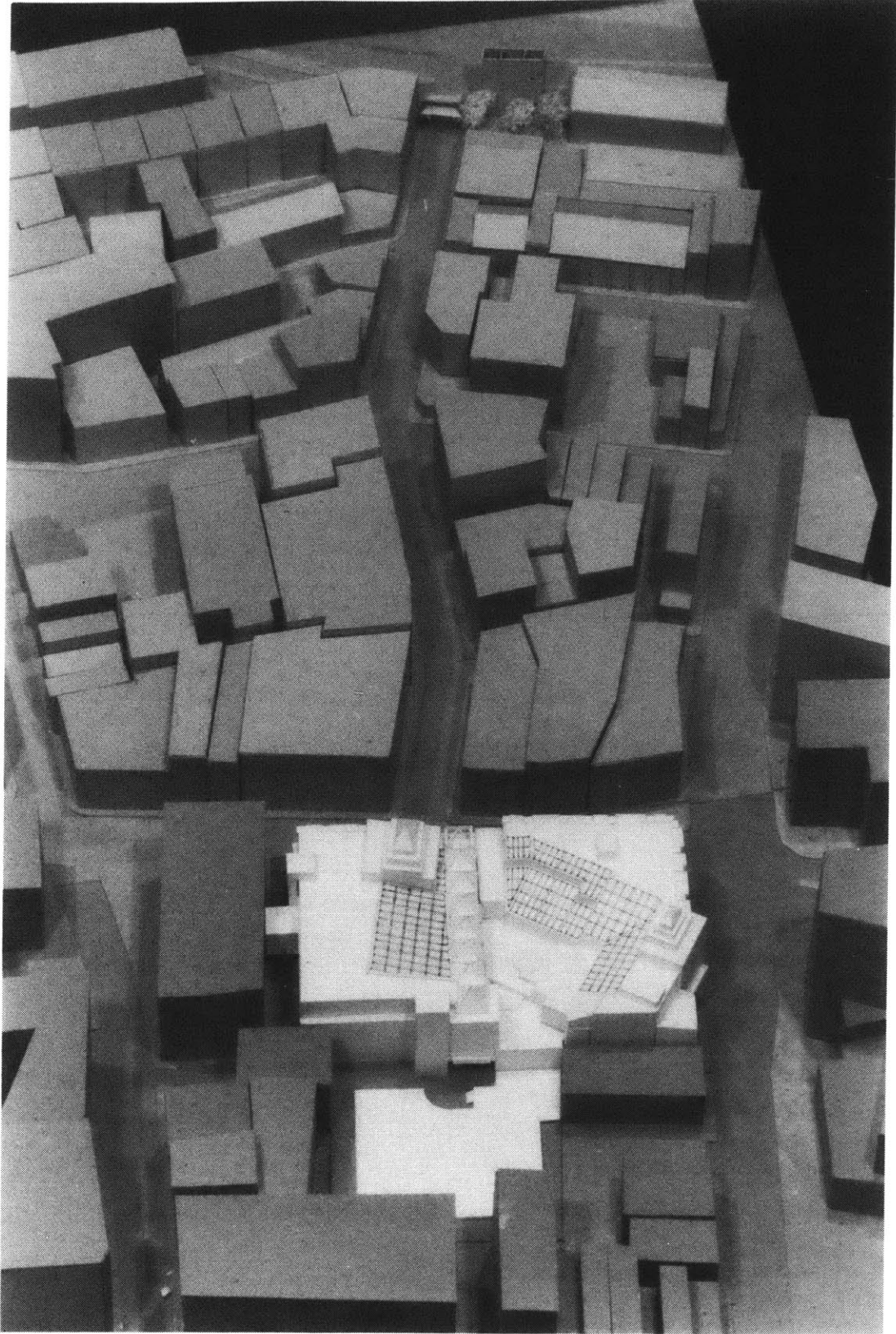

Fig. 6.2
MODEL PHOTO

View of looking back to the spine and the Chinatown gateway from the proposed building. The "series of Pavilions" symbolizes the future expansion of Chinatown along Beach street through the building into the rest of the city block.



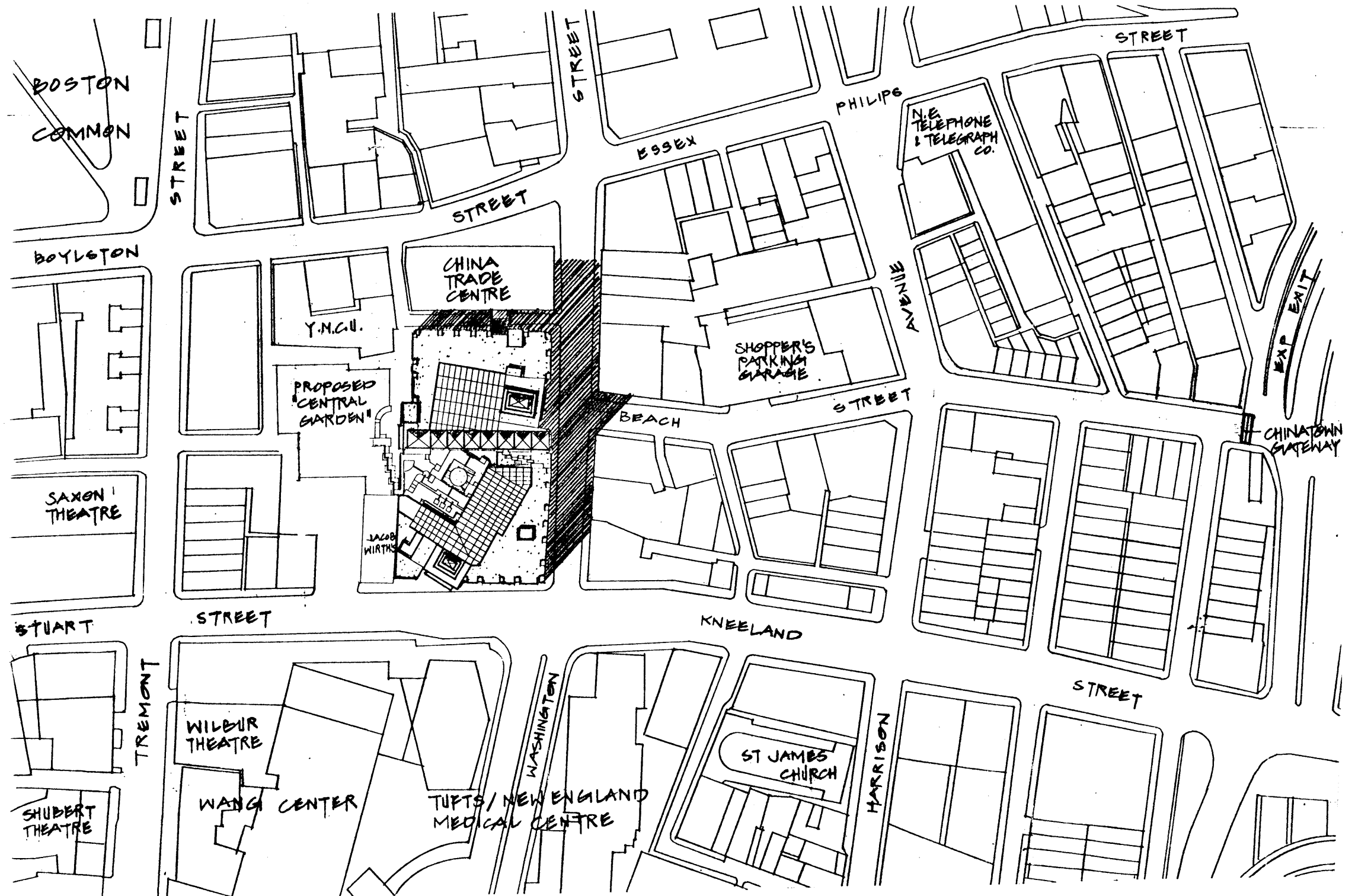
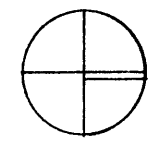
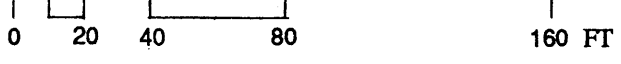

Fig. 6.3
SITE PLAN



- 1 Lobby
- 2 Gallery
- 3 Shop
- 4 Restaurant / snack
- 5 Kitchen
- 6 Bar / lounge
- 7 Theatre foyer
- 8 Auditorium
- 9 Stage
- 10 Backstage
- 11 Theatre workshop
- 12 Function / seminar room
- 13 Office
- 14 Library
- 15 Cooking school
- 16 Classroom
- 17 Studio
- 18 Seating
- 19 Pavilion
- 20 Washroom
- 21 Service core
- 22 Outdoor garden
- 23 Roof garden
- 24 Pool
- 25 Balcony
- 26 Open below
- 27 Atrium
- 28 Central garden
- 29 Ramp to basement
- 30 Underground service
- 31 Underground garage

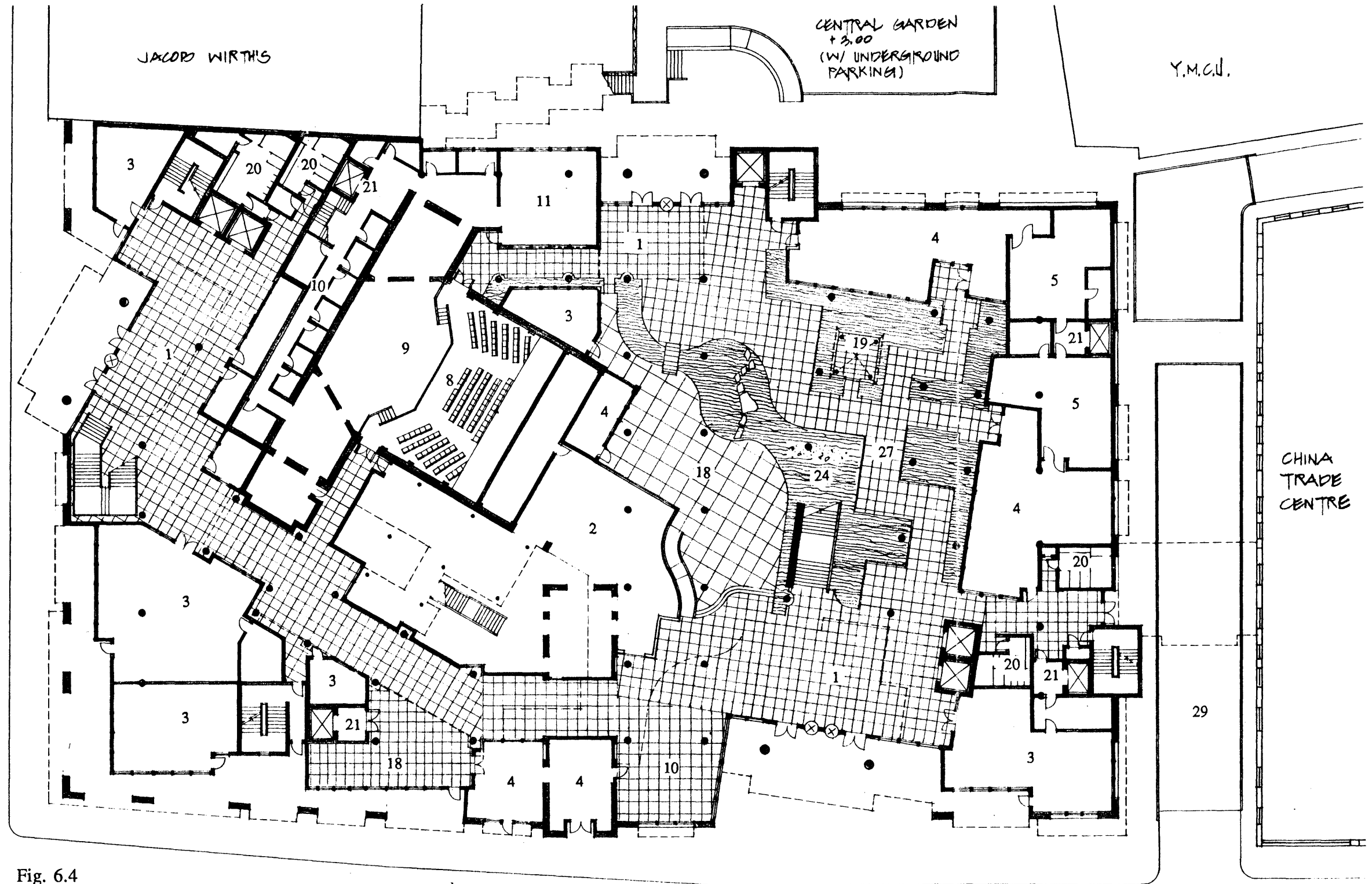
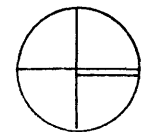

Fig. 6.4
GROUND FLOOR PLAN +10.00

0 10 20 40 80 FT



- 1 Lobby
- 2 Gallery
- 3 Shop
- 4 Restaurant / snack
- 5 Kitchen
- 6 Bar / lounge
- 7 Theatre foyer
- 8 Auditorium
- 9 Stage
- 10 Backstage
- 11 Theatre workshop
- 12 Function / seminar room
- 13 Office
- 14 Library
- 15 Cooking school
- 16 Classroom
- 17 Studio
- 18 Seating
- 19 Pavilion
- 20 Washroom
- 21 Service core
- 22 Outdoor garden
- 23 Roof garden
- 24 Pool
- 25 Balcony
- 26 Open below
- 27 Atrium
- 28 Central garden
- 29 Ramp to basement
- 30 Underground service
- 31 Underground garage

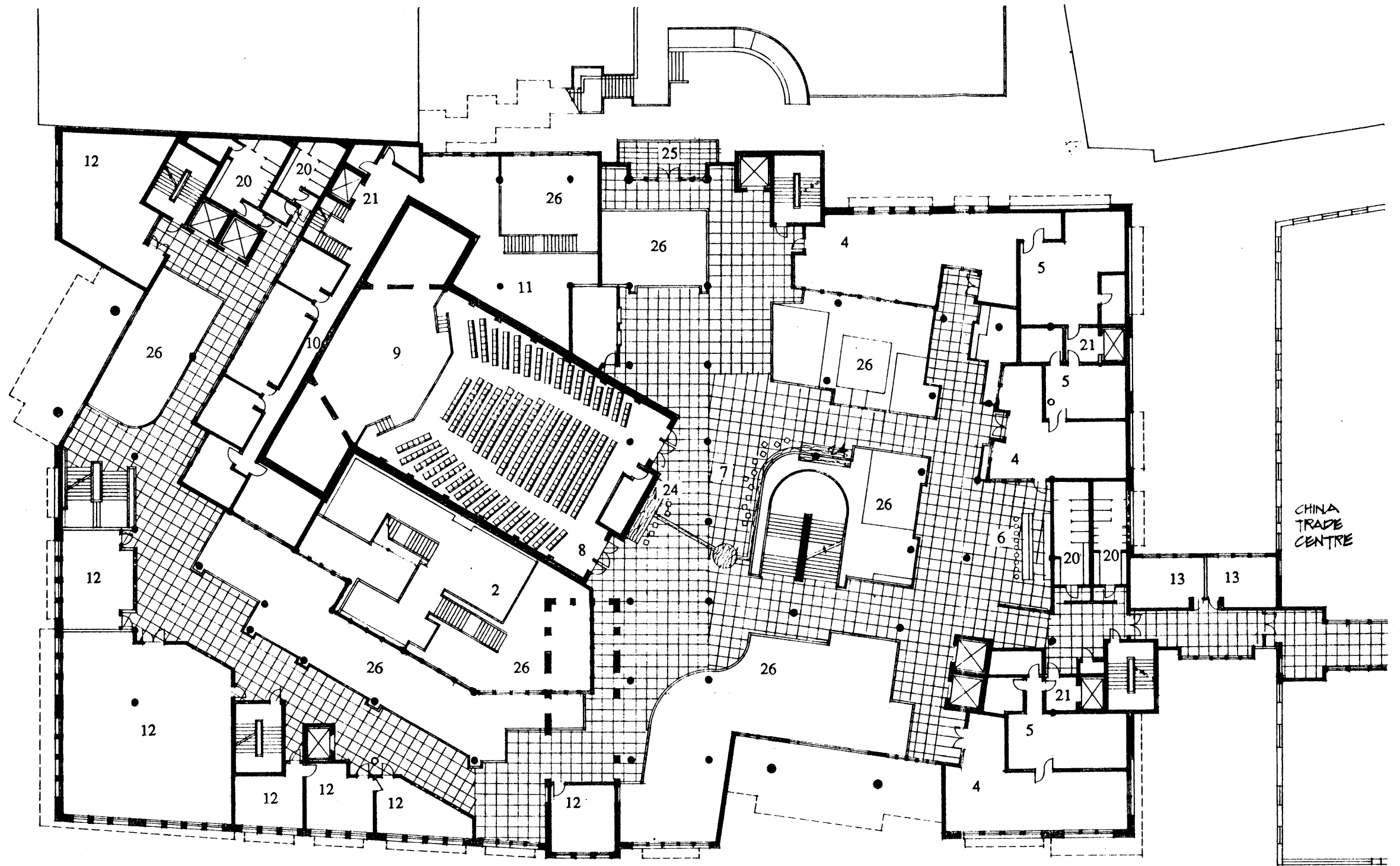
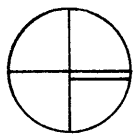
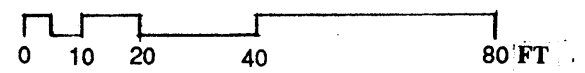

Fig. 6.5
SECOND FLOOR PLAN +18.00



- 1 Lobby
- 2 Gallery
- 3 Shop
- 4 Restaurant / snack
- 5 Kitchen
- 6 Bar / lounge
- 7 Theatre foyer
- 8 Auditorium
- 9 Stage
- 10 Backstage
- 11 Theatre workshop
- 12 Function / seminar room
- 13 Office
- 14 Library
- 15 Cooking school
- 16 Classroom
- 17 Studio
- 18 Seating
- 19 Pavilion
- 20 Washroom
- 21 Service core
- 22 Outdoor garden
- 23 Roof garden
- 24 Pool
- 25 Balcony
- 26 Open below
- 27 Atrium
- 28 Central garden
- 29 Ramp to basement
- 30 Underground service
- 31 Underground garage

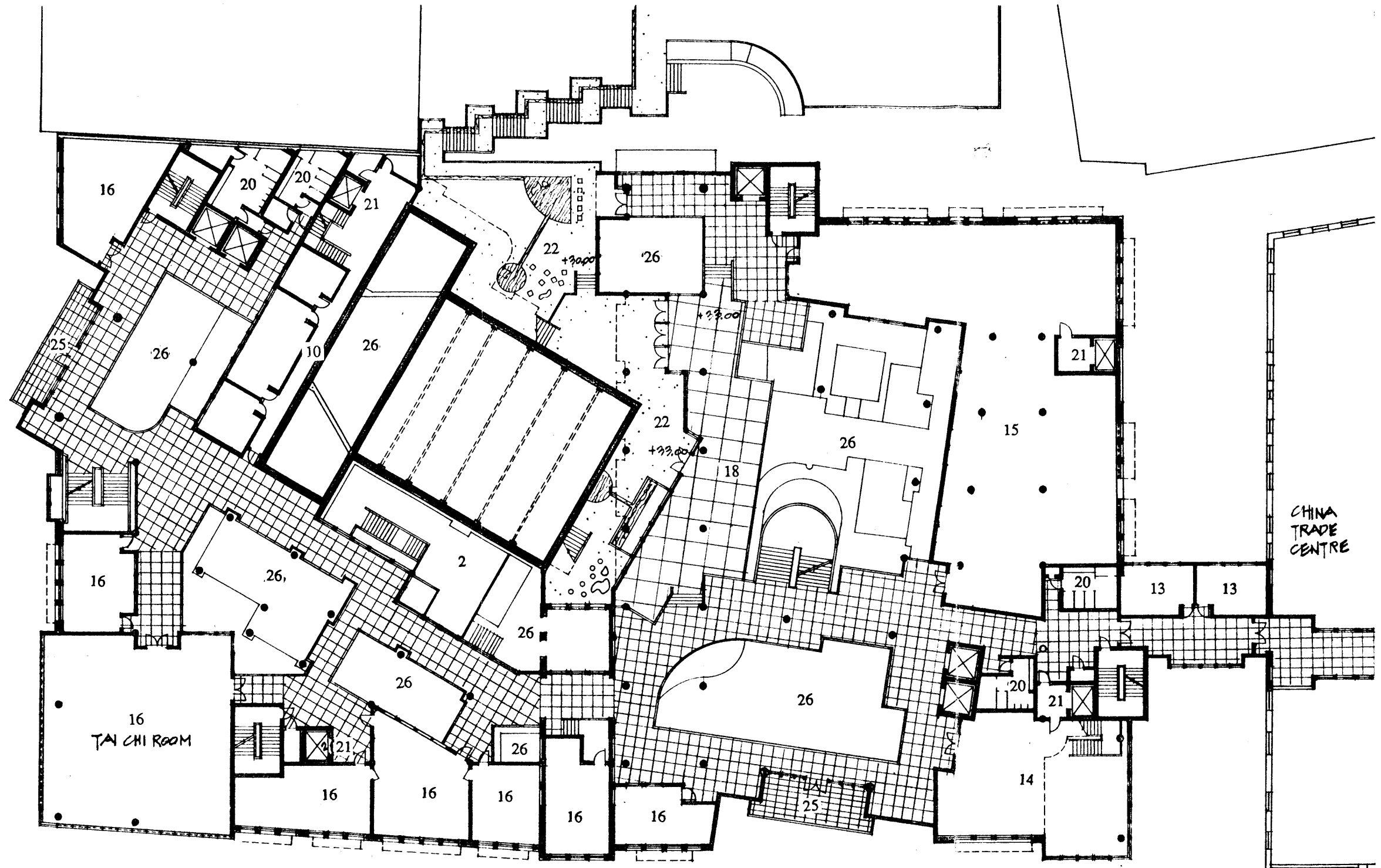
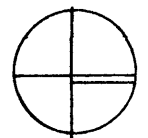
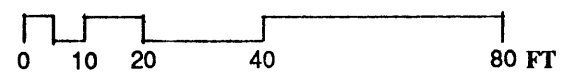

Fig. 6.6
THIRD FLOOR PLAN +30.00 +33.00



- 1 Lobby
- 2 Gallery
- 3 Shop
- 4 Restaurant / snack
- 5 Kitchen
- 6 Bar / lounge
- 7 Theatre foyer
- 8 Auditorium
- 9 Stage
- 10 Backstage
- 11 Theatre workshop
- 12 Function / seminar room
- 13 Office
- 14 Library
- 15 Cooking school
- 16 Classroom
- 17 Studio
- 18 Seating
- 19 Pavilion
- 20 Washroom
- 21 Service core
- 22 Outdoor garden
- 23 Roof garden
- 24 Pool
- 25 Balcony
- 26 Open below
- 27 Atrium
- 28 Central garden
- 29 Ramp to basement
- 30 Underground service
- 31 Underground garage

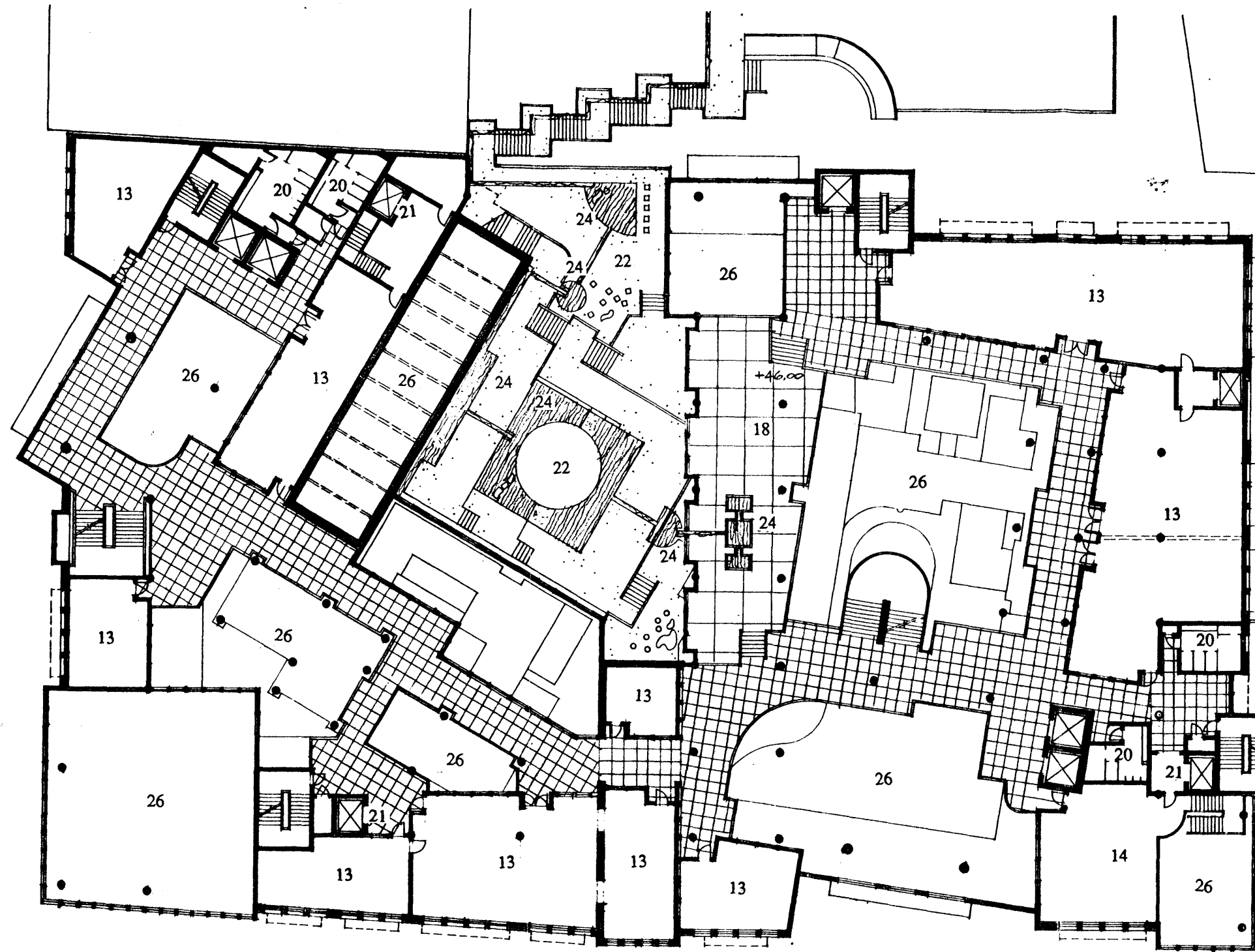
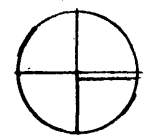
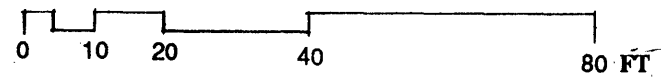

Fig. 6.7
FOURTH FLOOR PLAN +42.00 +46.00



- 1 Lobby
- 2 Gallery
- 3 Shop
- 4 Restaurant / snack
- 5 Kitchen
- 6 Bar / lounge
- 7 Theatre foyer
- 8 Auditorium
- 9 Stage
- 10 Backstage
- 11 Theatre workshop
- 12 Function / seminar room
- 13 Office
- 14 Library
- 15 Cooking school
- 16 Classroom
- 17 Studio
- 18 Seating
- 19 Pavilion
- 20 Washroom
- 21 Service core
- 22 Outdoor garden
- 23 Roof garden
- 24 Pool
- 25 Balcony
- 26 Open below
- 27 Atrium
- 28 Central garden
- 29 Ramp to basement
- 30 Underground service
- 31 Underground garage

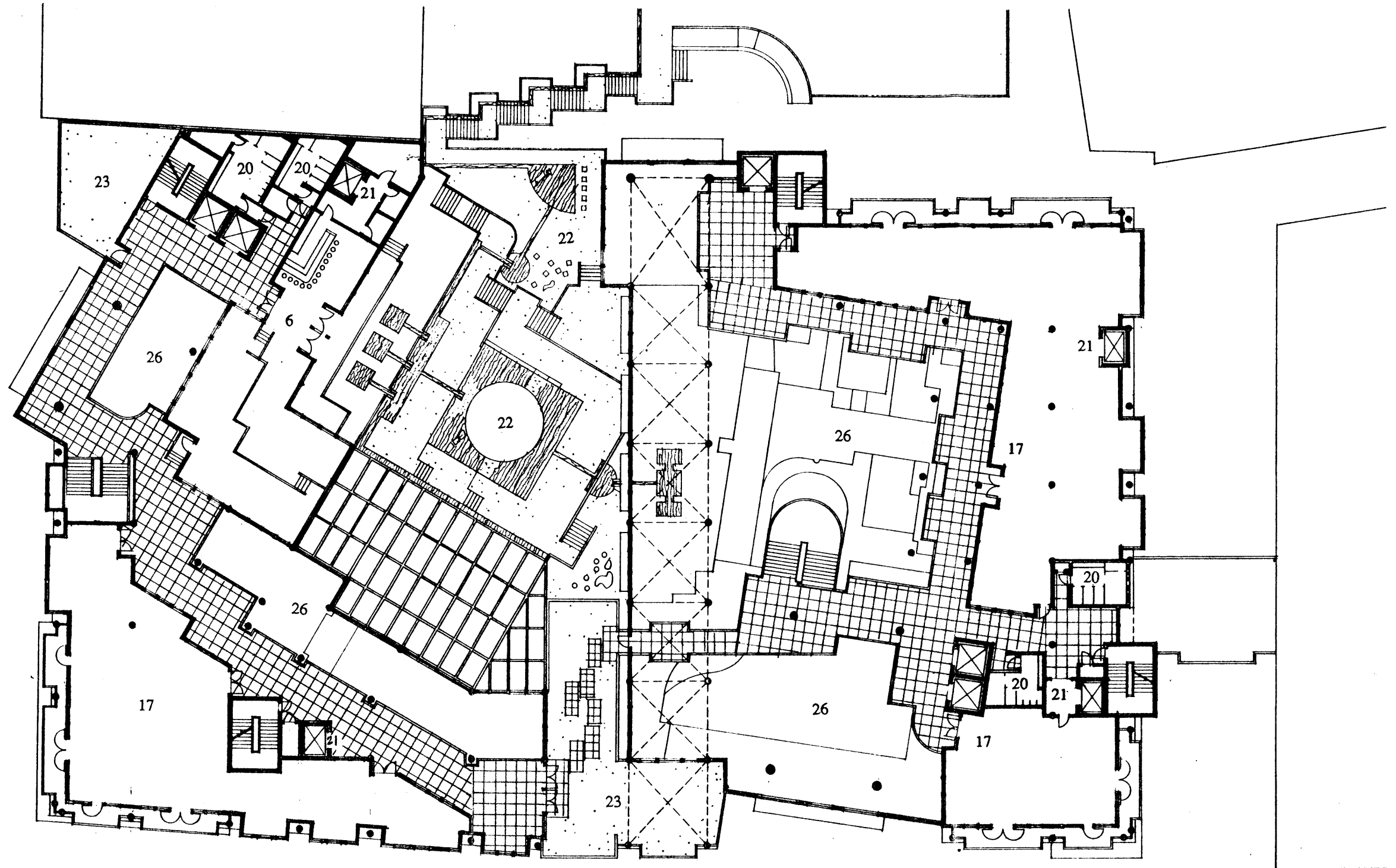
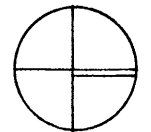
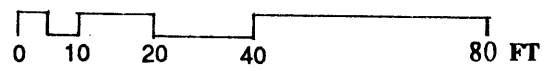
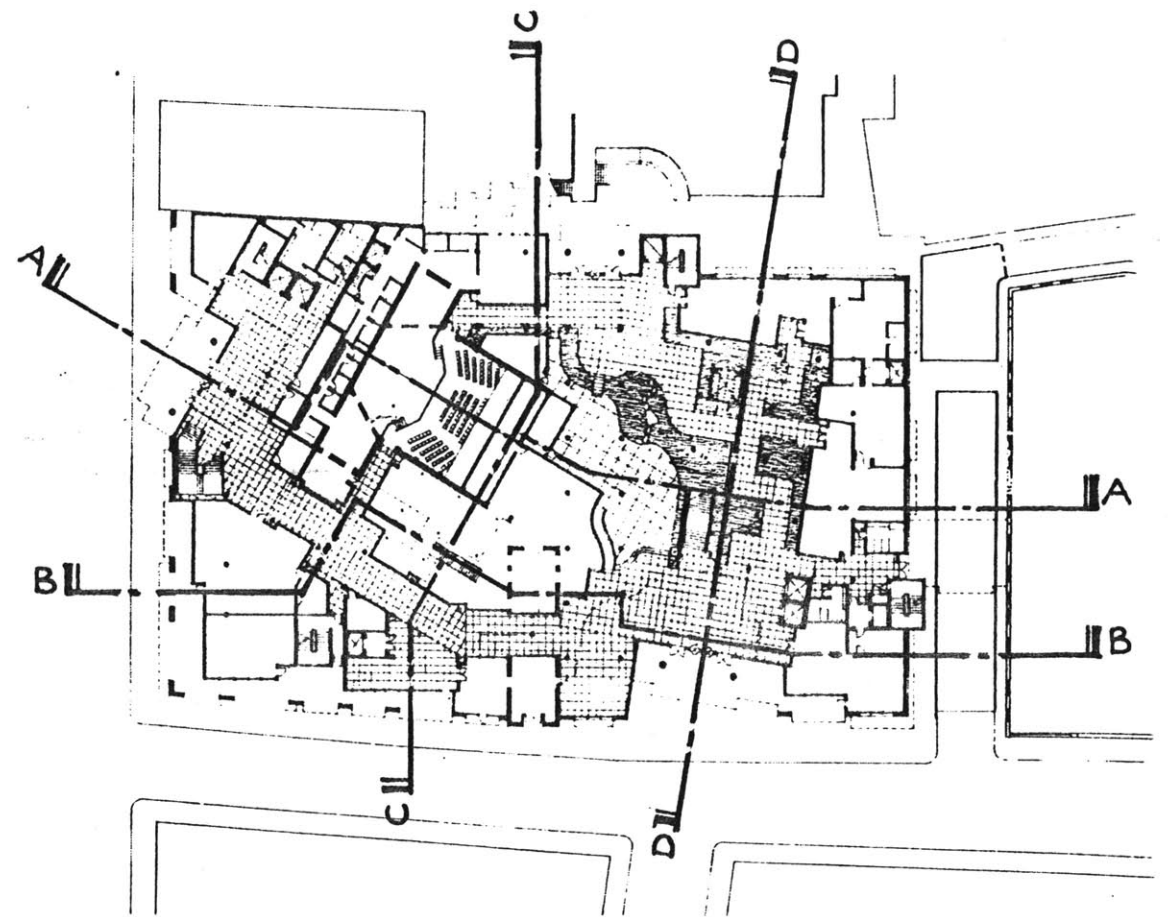

Fig. 6.8
FIFTH FLOOR PLAN +54.00





- | | |
|----------------------------|------------------------|
| 1 Lobby | 21 Service core |
| 2 Gallery | 22 Outdoor garden |
| 3 Shop | 23 Roof garden |
| 4 Restaurant / snack | 24 Pool |
| 5 Kitchen | 25 Balcony |
| 6 Bar / lounge | 26 Open below |
| 7 Theatre foyer | 27 Atrium |
| 8 Auditorium | 28 Central garden |
| 9 Stage | 29 Ramp to basement |
| 10 Backstage | 30 Underground service |
| 11 Theatre workshop | 31 Underground garage |
| 12 Function / seminar room | |
| 13 Office | |
| 14 Library | |
| 15 Cooking school | |
| 16 Classroom | |
| 17 Studio | |
| 18 Seating | |
| 19 Pavilion | |
| 20 Washroom | |

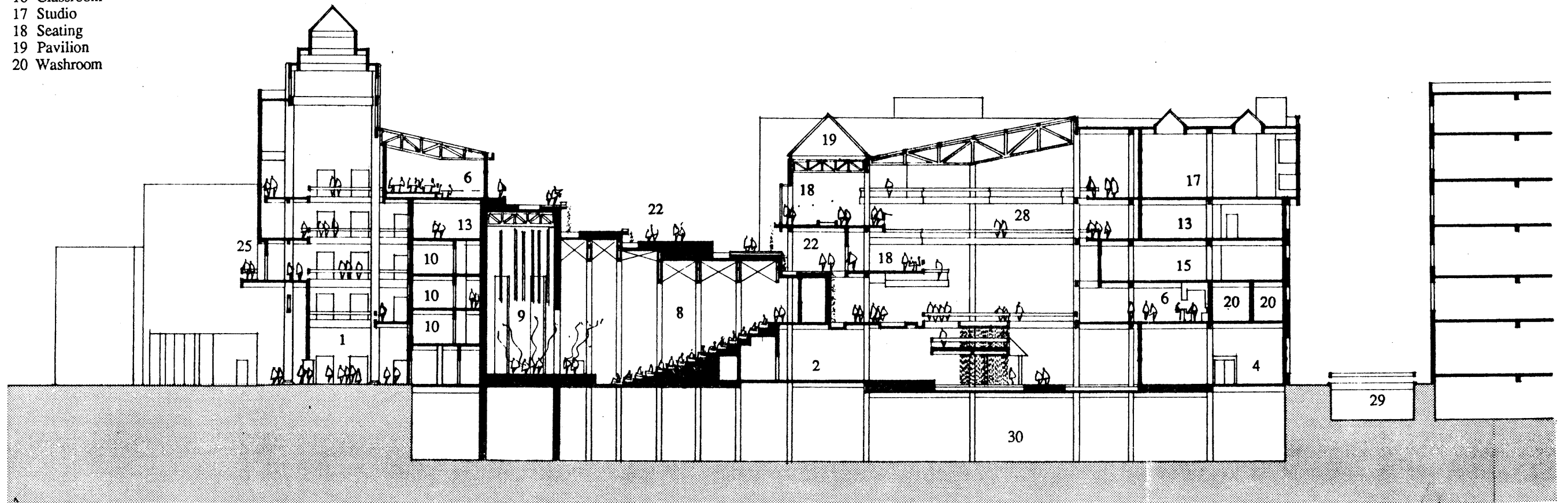
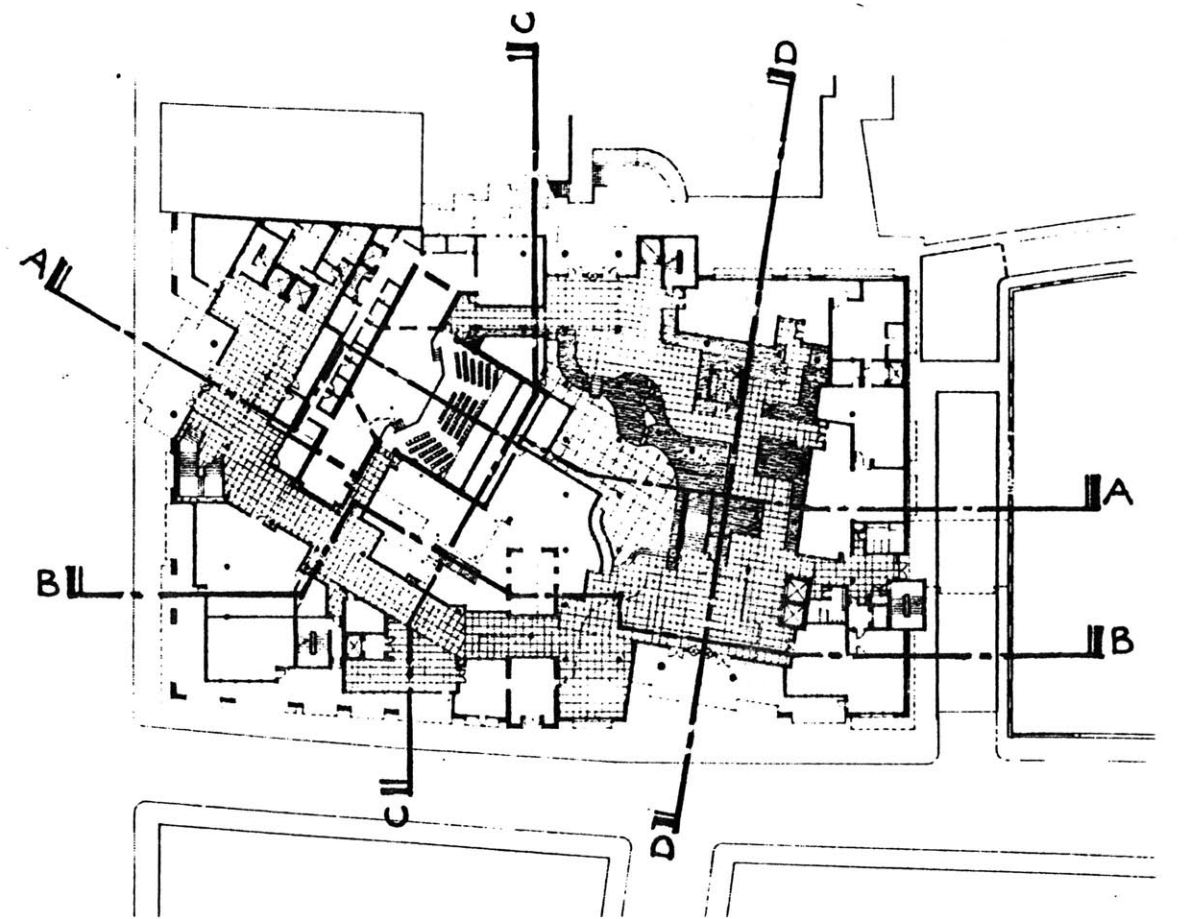

Fig. 6.9
EAST-WEST SECTION AA
 0 10 20 40 60 FT



- 1 Lobby
- 2 Gallery
- 3 Shop
- 4 Restaurant / snack
- 5 Kitchen
- 6 Bar / lounge
- 7 Theatre foyer
- 8 Auditorium
- 9 Stage
- 10 Backstage
- 11 Theatre workshop
- 12 Function / seminar room
- 13 Office
- 14 Library
- 15 Cooking school
- 16 Classroom
- 17 Studio
- 18 Seating
- 19 Pavilion
- 20 Washroom
- 21 Service core
- 22 Outdoor garden
- 23 Roof garden
- 24 Pool
- 25 Balcony
- 26 Open below
- 27 Atrium
- 28 Central garden
- 29 Ramp to basement
- 30 Underground service
- 31 Underground garage

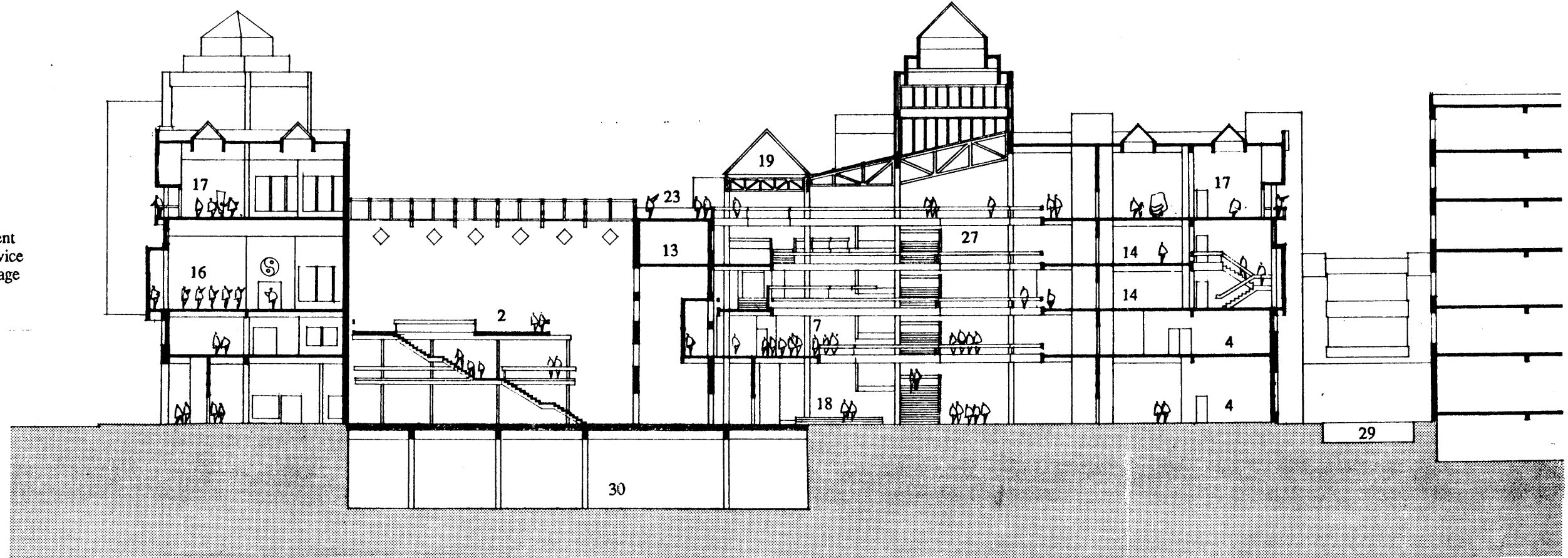
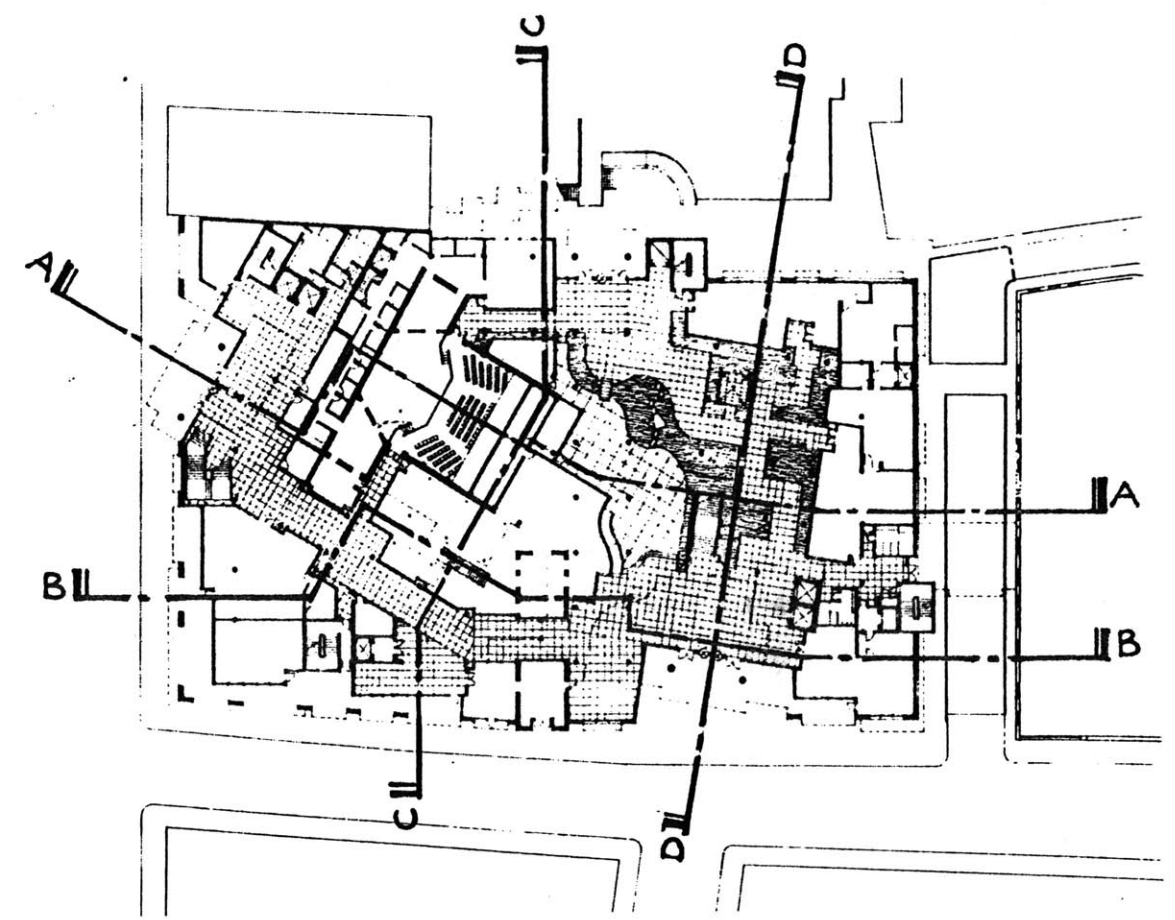

Fig. 6.10
EAST-WEST SECTION BB
 0 10 20 40 80 FT



- 1 Lobby
- 2 Gallery
- 3 Shop
- 4 Restaurant / snack
- 5 Kitchen
- 6 Bar / lounge
- 7 Theatre foyer
- 8 Auditorium
- 9 Stage
- 10 Backstage
- 11 Theatre workshop
- 12 Function / seminar room
- 13 Office
- 14 Library
- 15 Cooking school
- 16 Classroom
- 17 Studio
- 18 Seating
- 19 Pavilion
- 20 Washroom
- 21 Service core
- 22 Outdoor garden
- 23 Roof garden
- 24 Pool
- 25 Balcony
- 26 Open below
- 27 Atrium
- 28 Central garden
- 29 Ramp to basement
- 30 Underground service
- 31 Underground garage

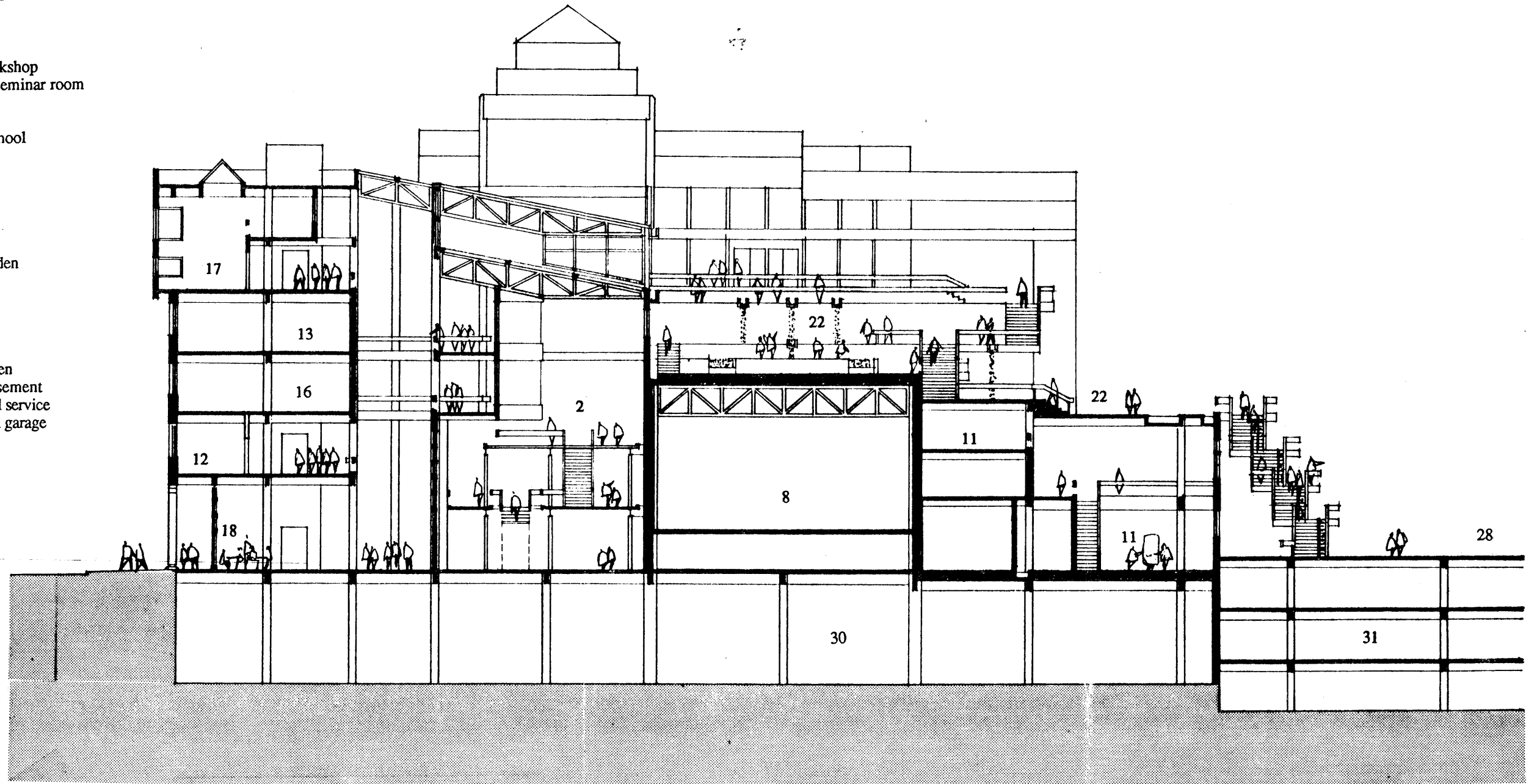
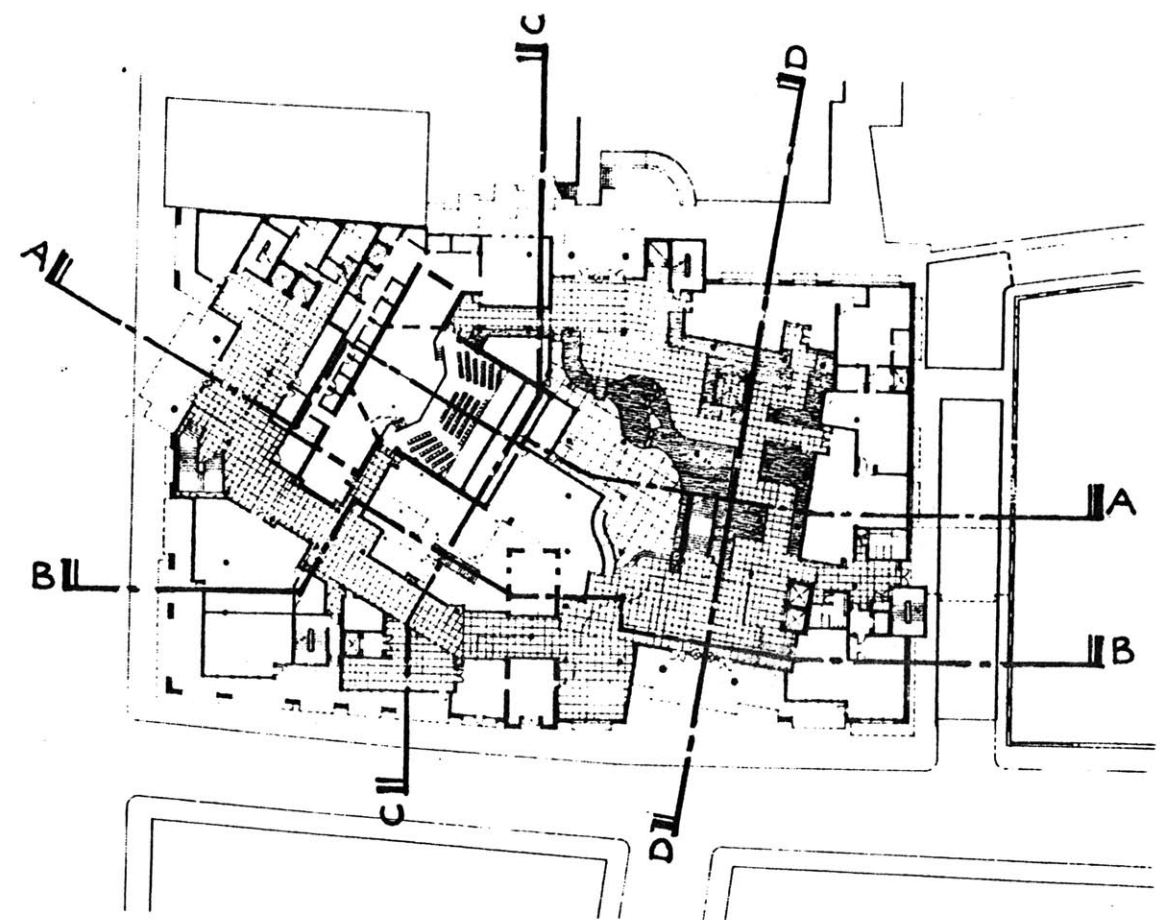

Fig. 6.11
SOUTH-NORTH SECTION CC

0 10 20 40 80 FT



- 1 Lobby
- 2 Gallery
- 3 Shop
- 4 Restaurant / snack
- 5 Kitchen
- 6 Bar / lounge
- 7 Theatre foyer
- 8 Auditorium
- 9 Stage
- 10 Backstage
- 11 Theatre workshop
- 12 Function / seminar room
- 13 Office
- 14 Library
- 15 Cooking school
- 16 Classroom
- 17 Studio
- 18 Seating
- 19 Pavilion
- 20 Washroom
- 21 Service core
- 22 Outdoor garden
- 23 Roof garden
- 24 Pool
- 25 Balcony
- 26 Open below
- 27 Atrium
- 28 Central garden
- 29 Ramp to basement
- 30 Underground service
- 31 Underground garage

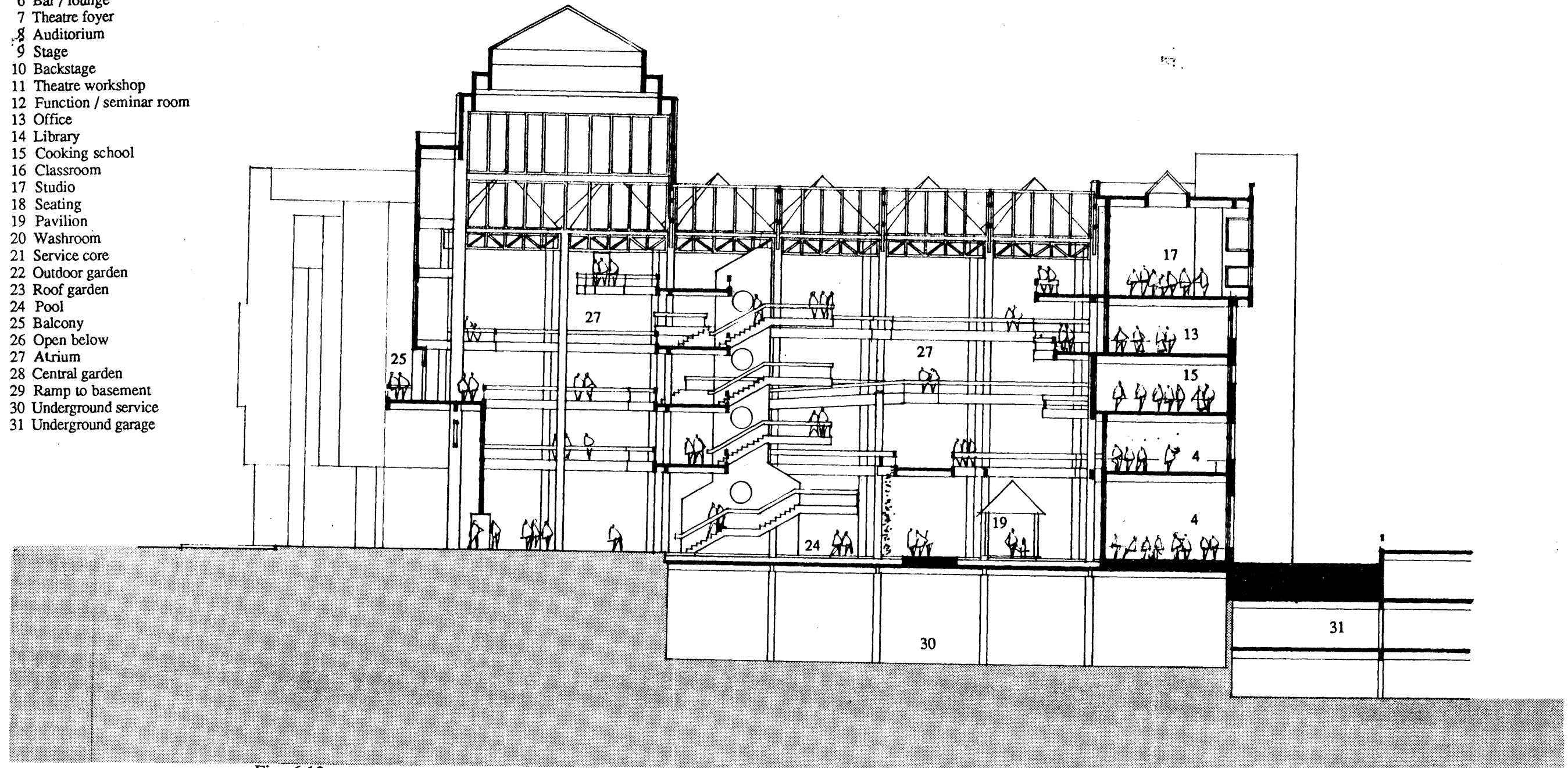

Fig. 6.12
SOUTH-NORTH SECTION DD

0 10 20 30 FT

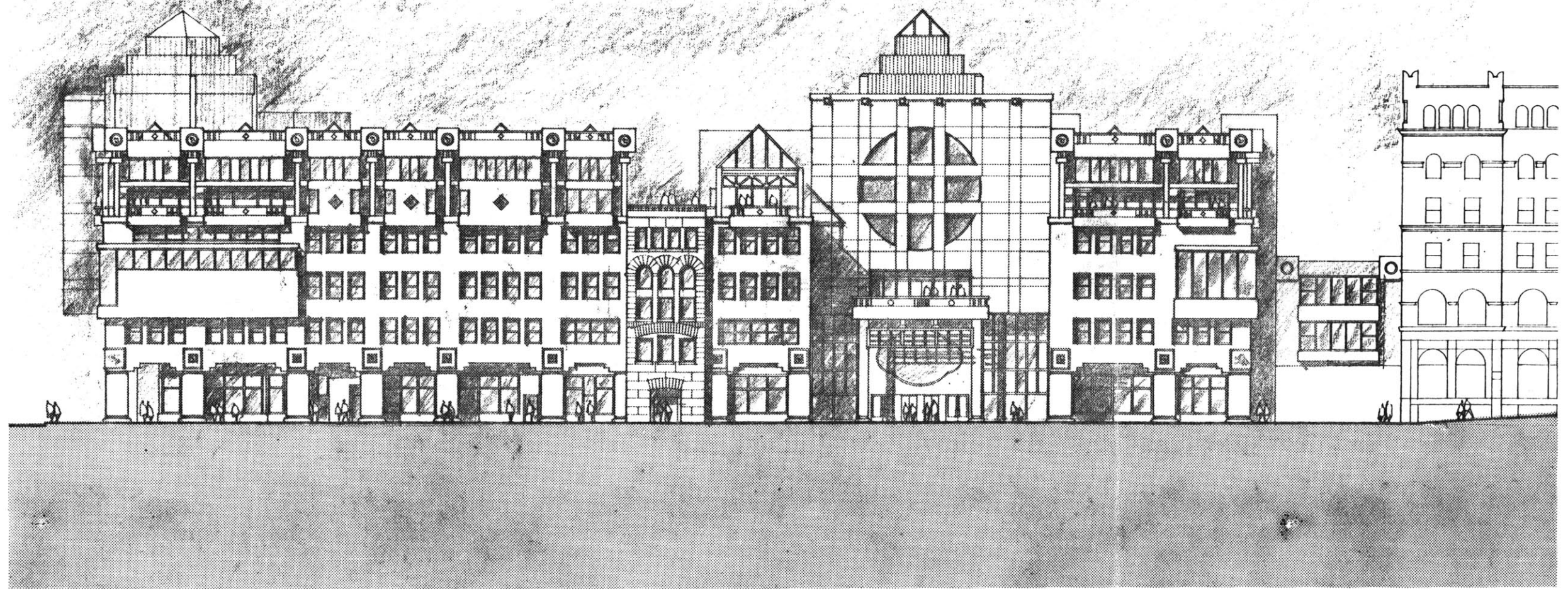

Fig. 6.13
EAST ELEVATION
(Facing Washington street)



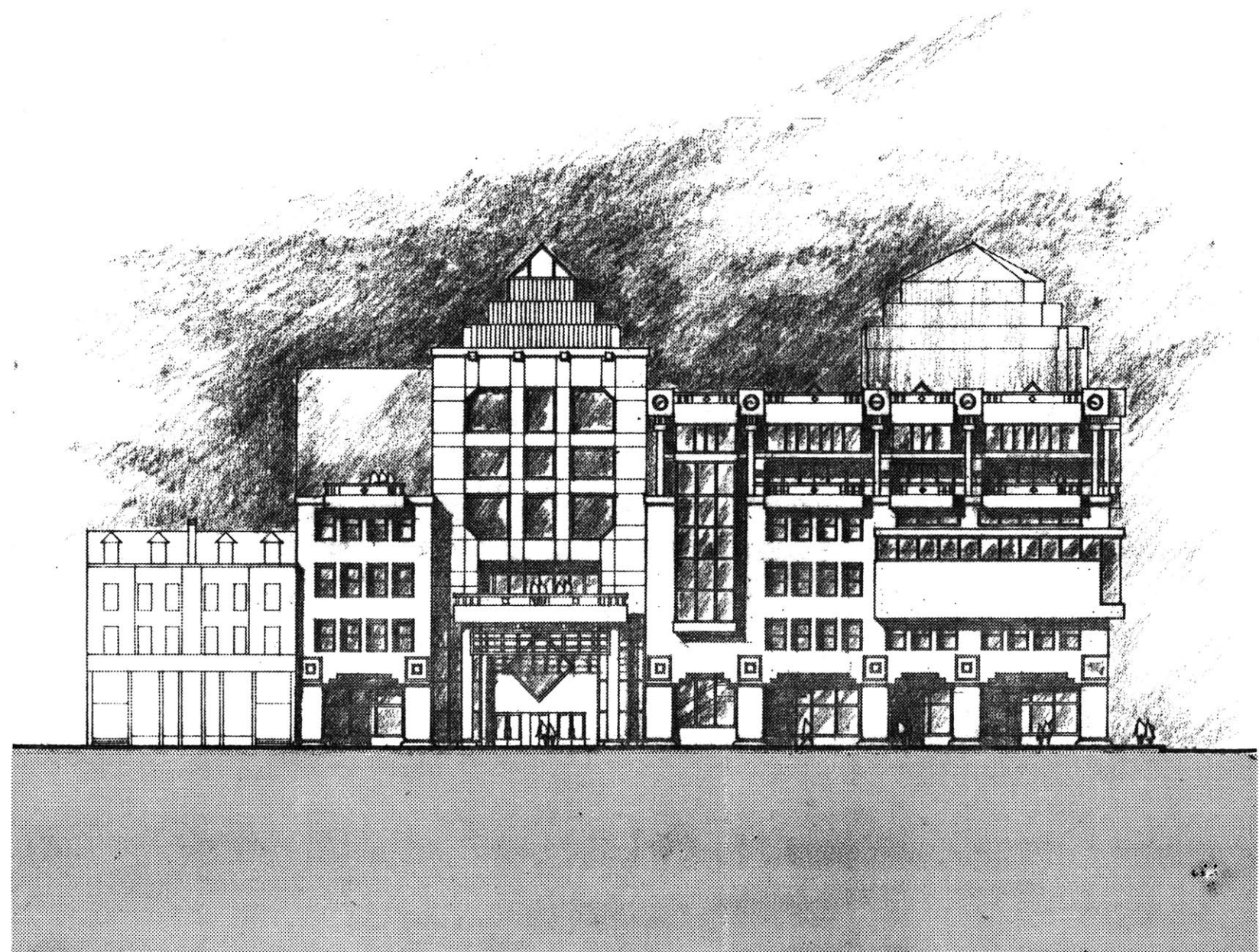
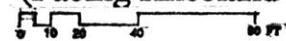

Fig. 6.14
SOUTH ELEVATION
(Facing Kneeland street)



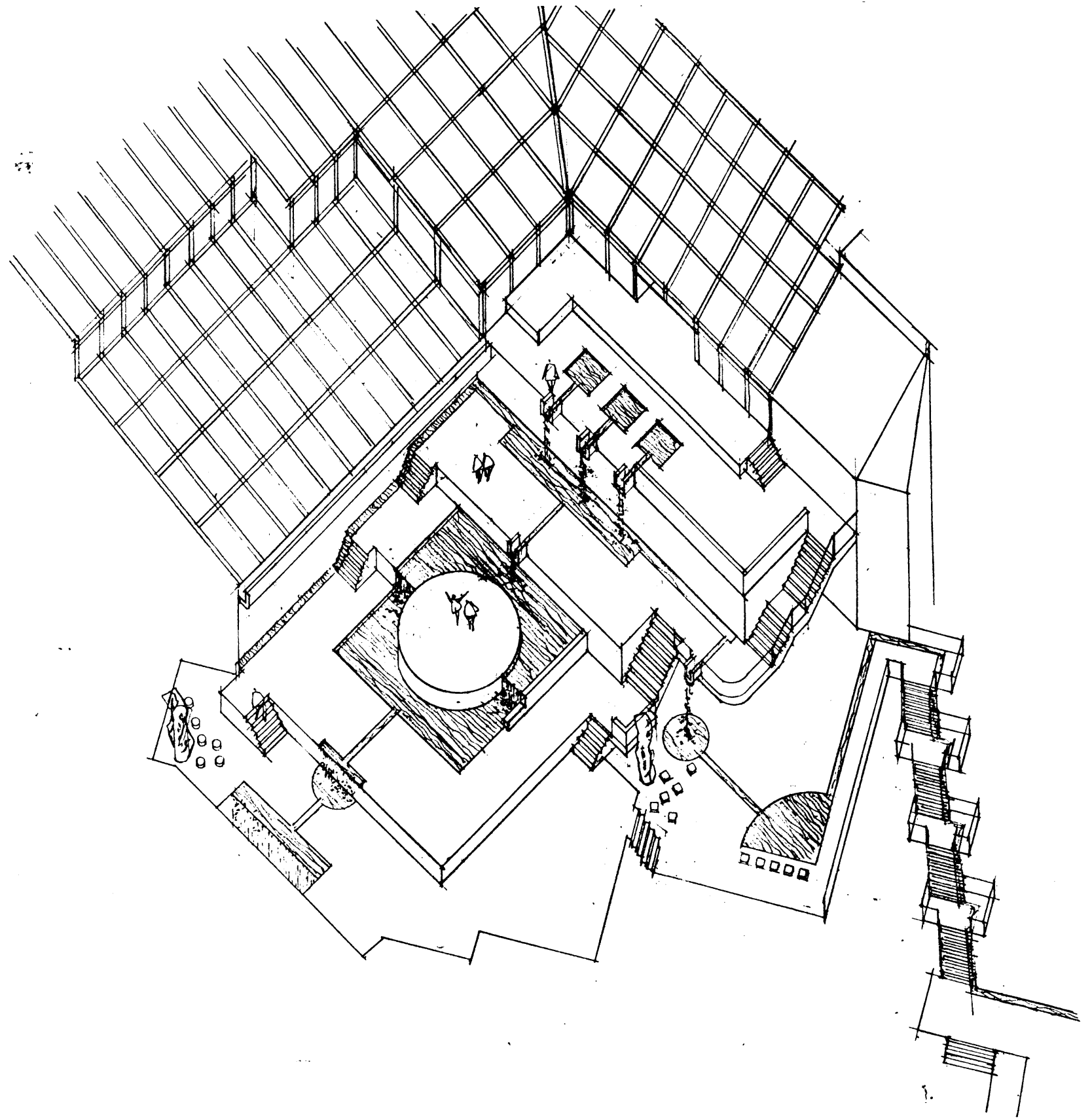

Fig. 6.15
AXONOMETRIC OF OUTDOOR GARDEN

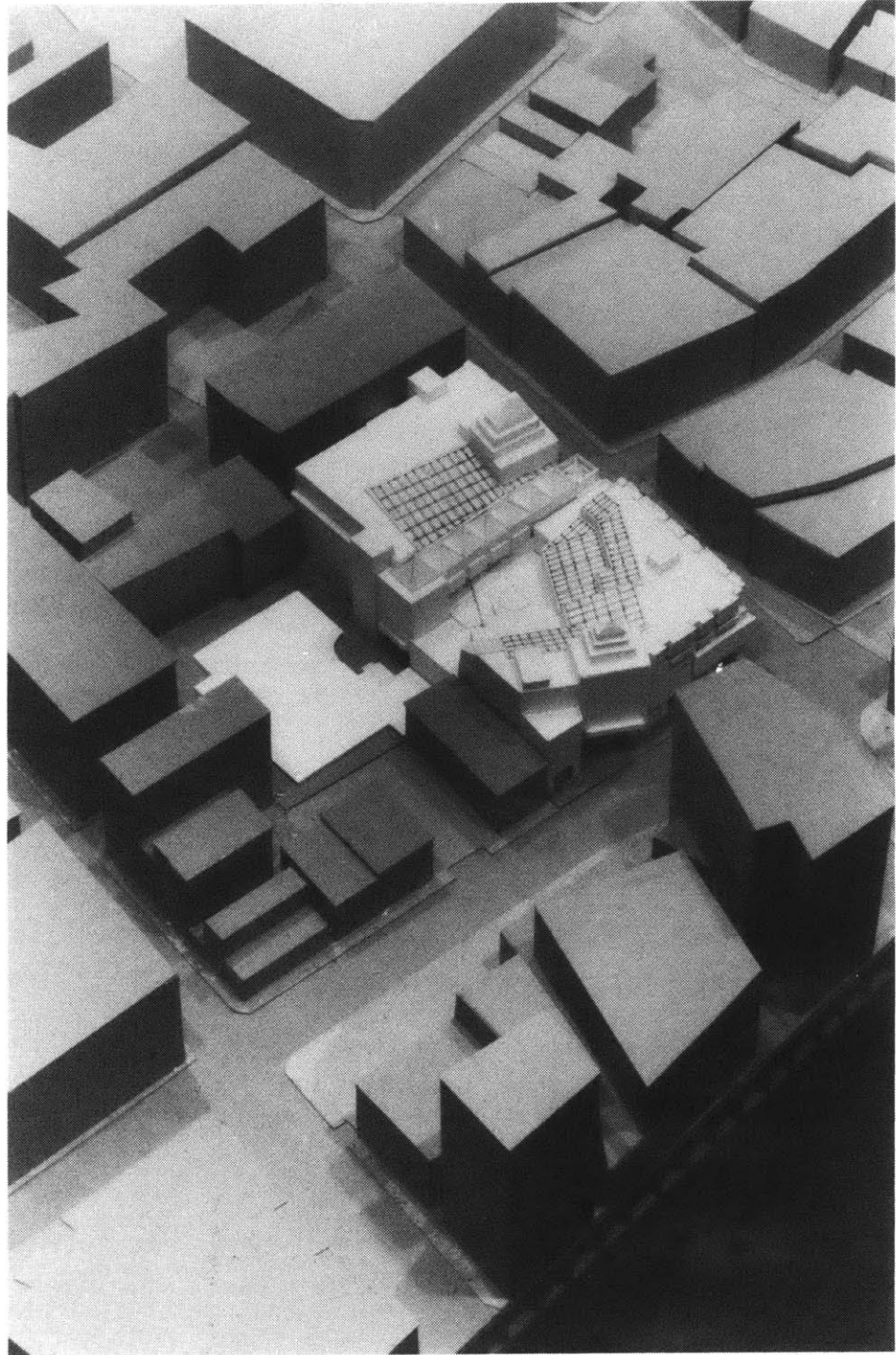

Fig. 6.18
MODEL PHOTO
The "Round Heaven, Square Earth"
orthodoxy is applied as the controlling
principle of
geometric elements in the outdoor garden.
the two "pagoda gateways" are "borrowed"
into the garden as "distant views"

Fig. 6.19
MODEL PHOTO
The four entrances addressing the contexts:
the projected elements in the facade come
from the object-like nature of the Hayden
Building which lies within the site.

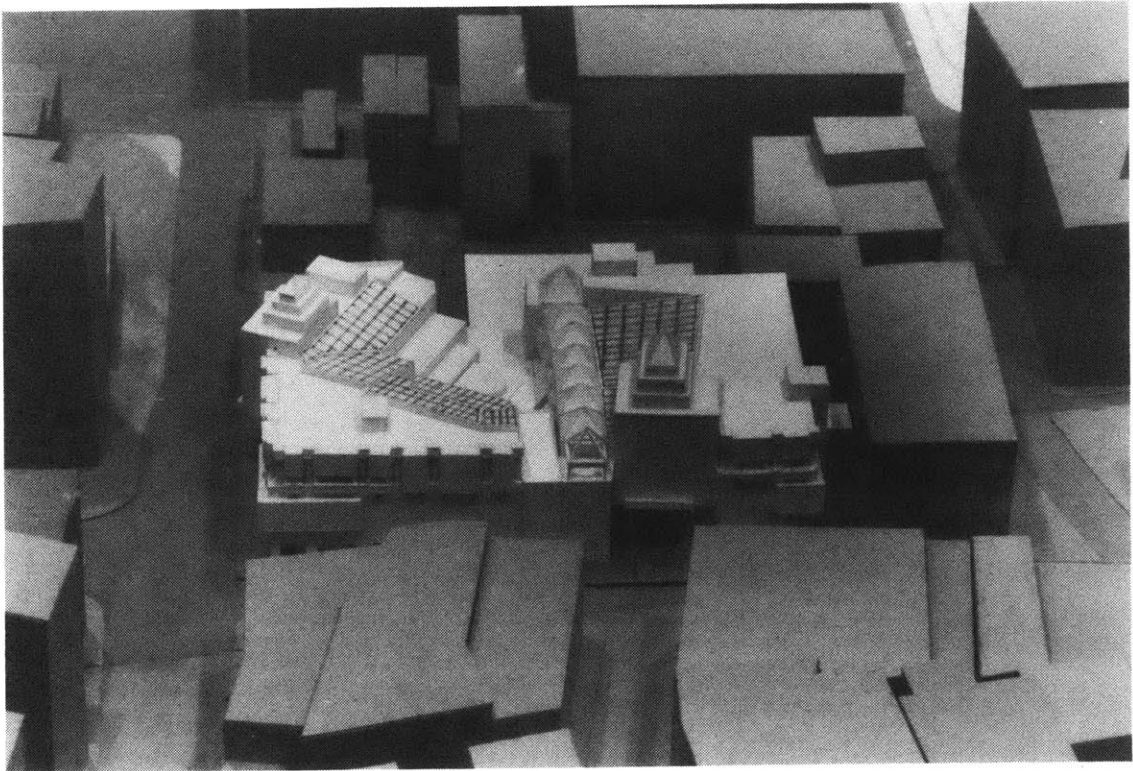
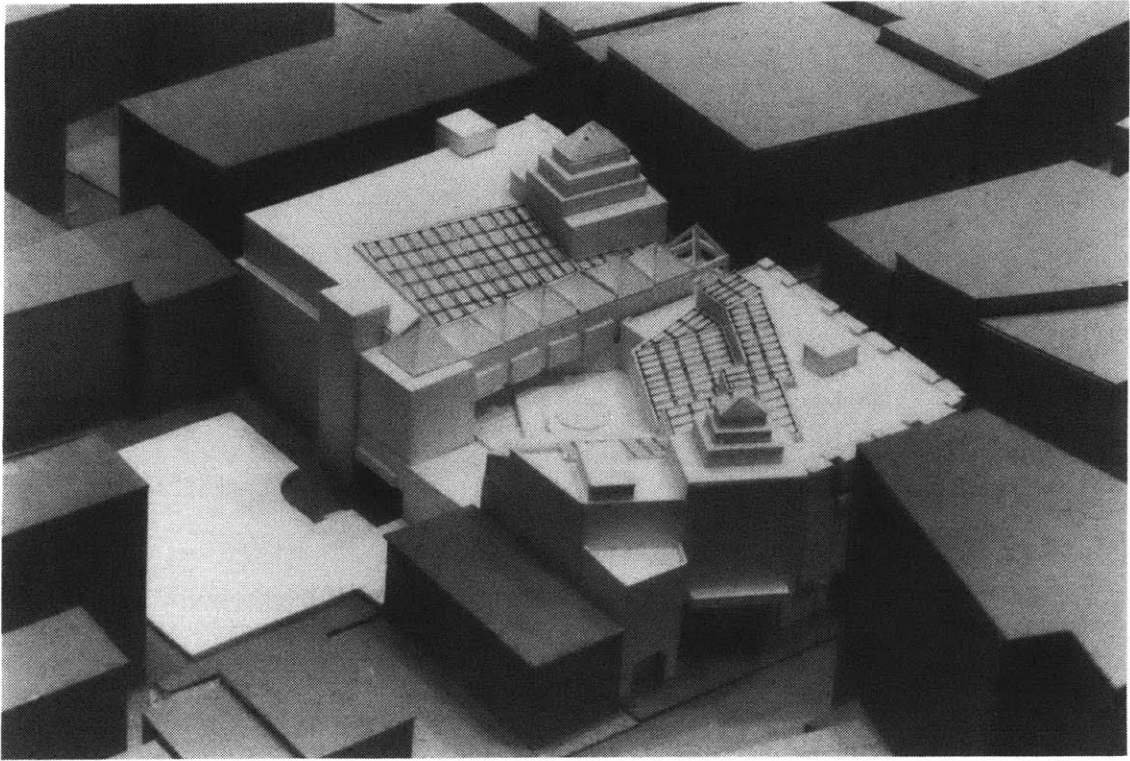

Fig. 6.20
MODEL PHOTO
View of the proposed building from
Tufts/New England Medical Centre. No
entrances attempt to address to
Tufts/N.E.M.C.
Note the continuity of elements at the
building corner.

Fig. 6.21
MODEL PHOTO
View of the proposed building from
Washington street looking south. Note the
pavilion frame adjacent to the Washington
entrance.

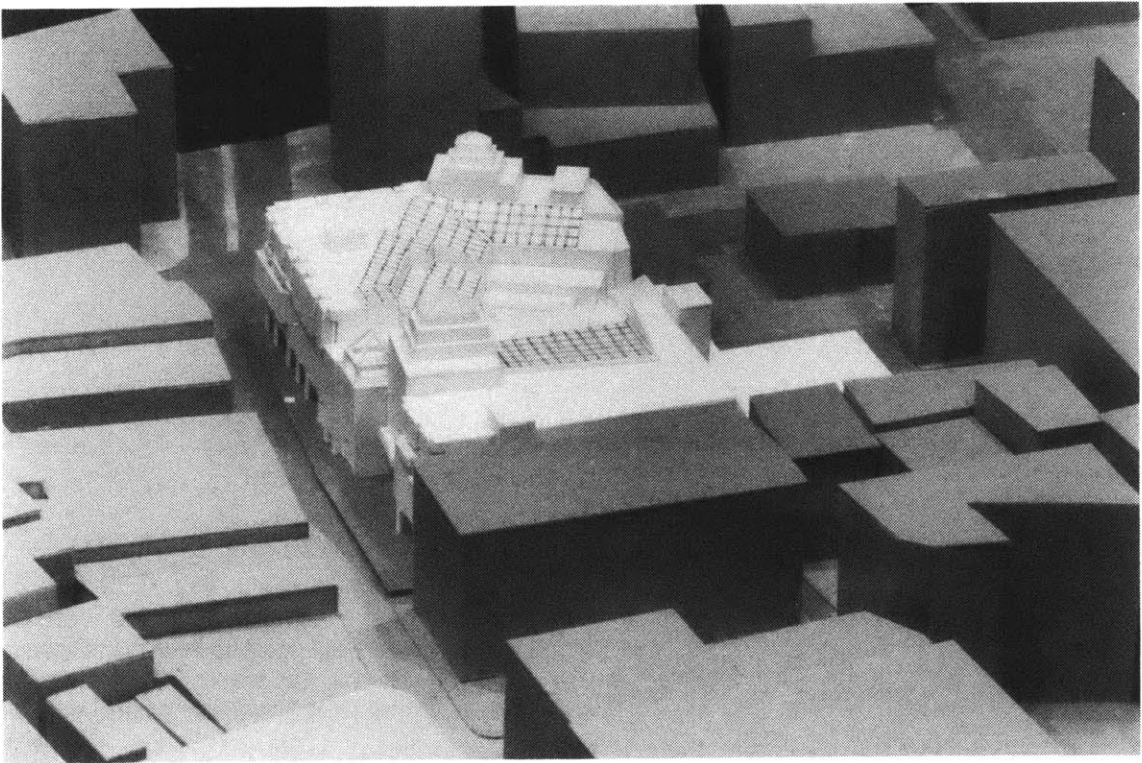
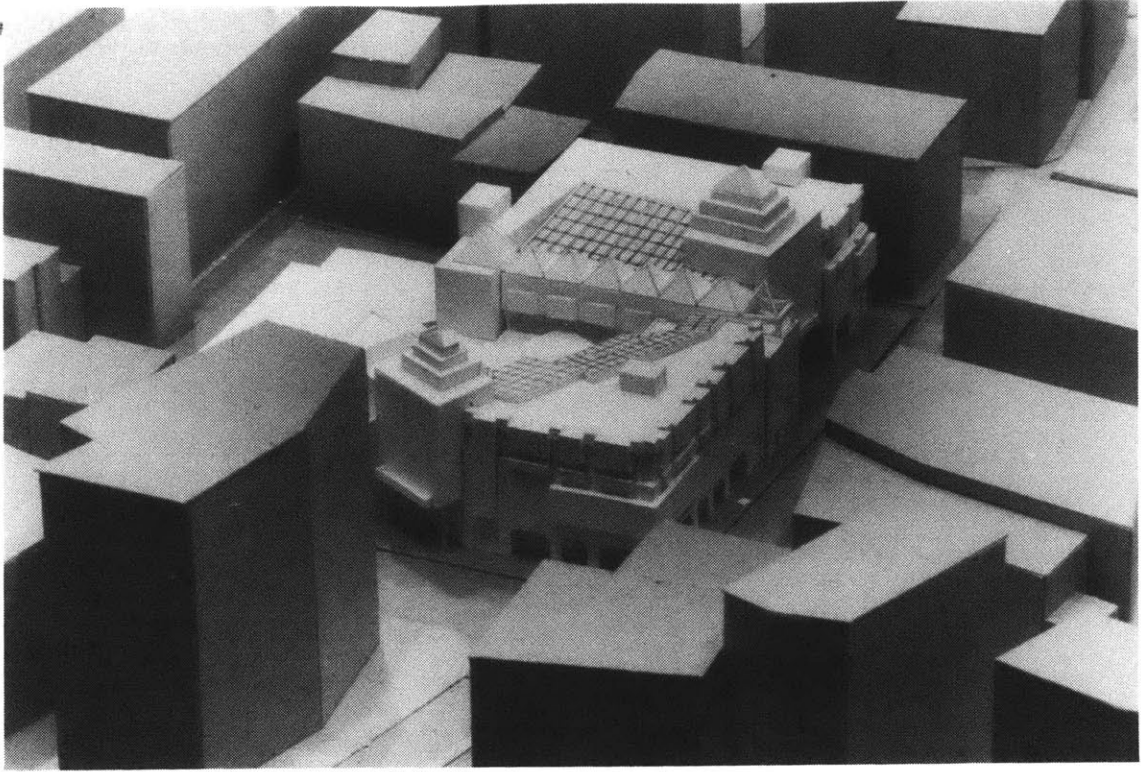

Fig. 6.22 & 6.23
Study Model of Volume
This study model helped to determine the volume of
the whole complex. The idea of an outdoor garden
enclosed on three sides by building mass emerged at
this stage.

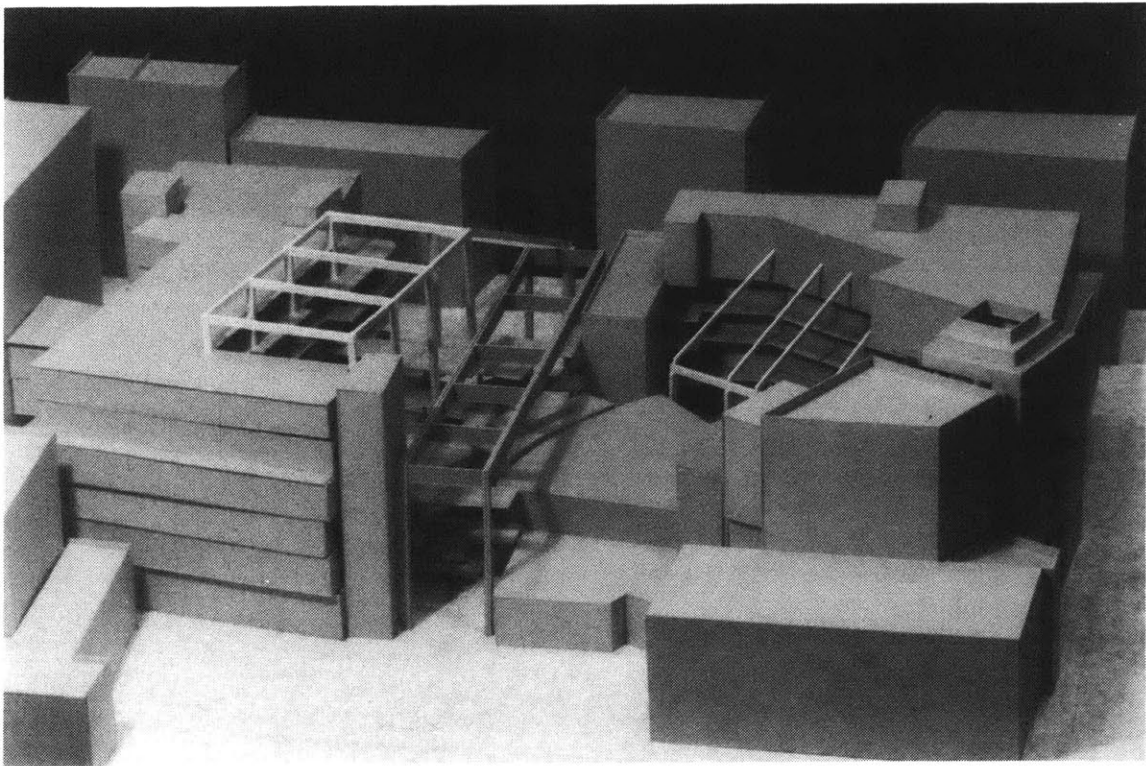
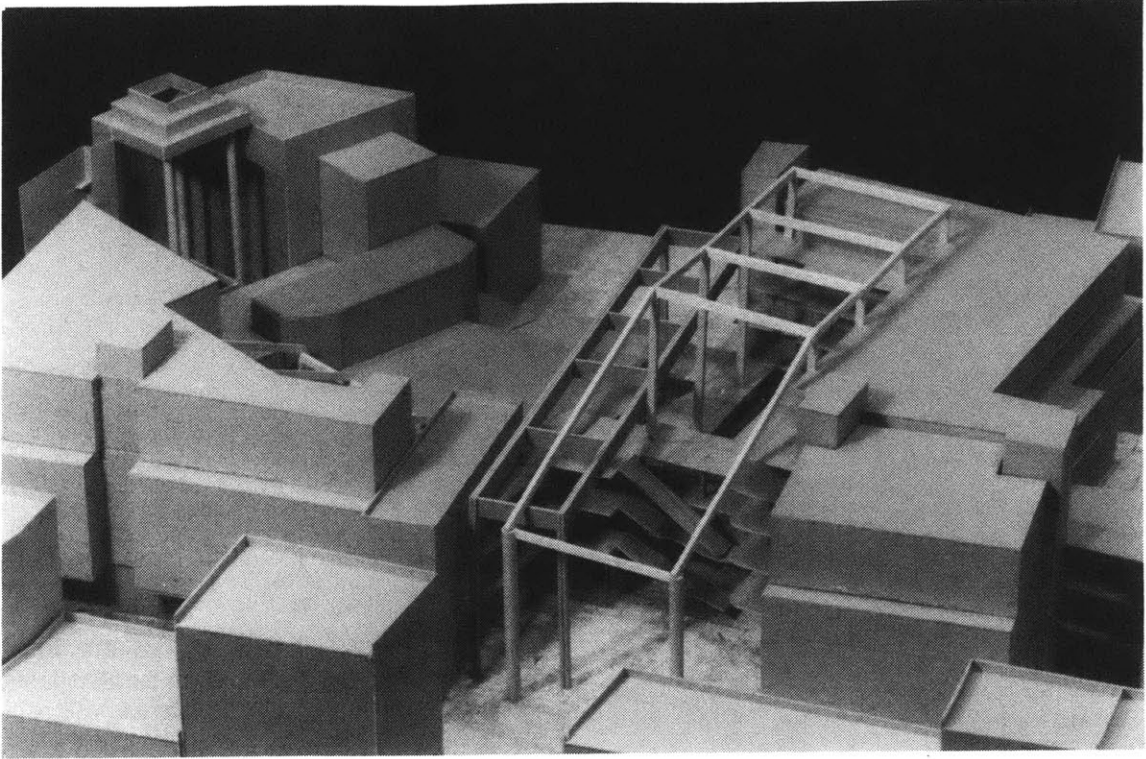

Fig. 6.24

Study model of roof structures.

The roof structures are more in order: the glazed roofs are all sloping towards the outdoor garden, except the "series of pavilions" which is directional for the notion of Chinatown expansion.

Fig. 6.25

MODEL PHOTO

A photocopy of the east facade is pasted up to study the elevation.

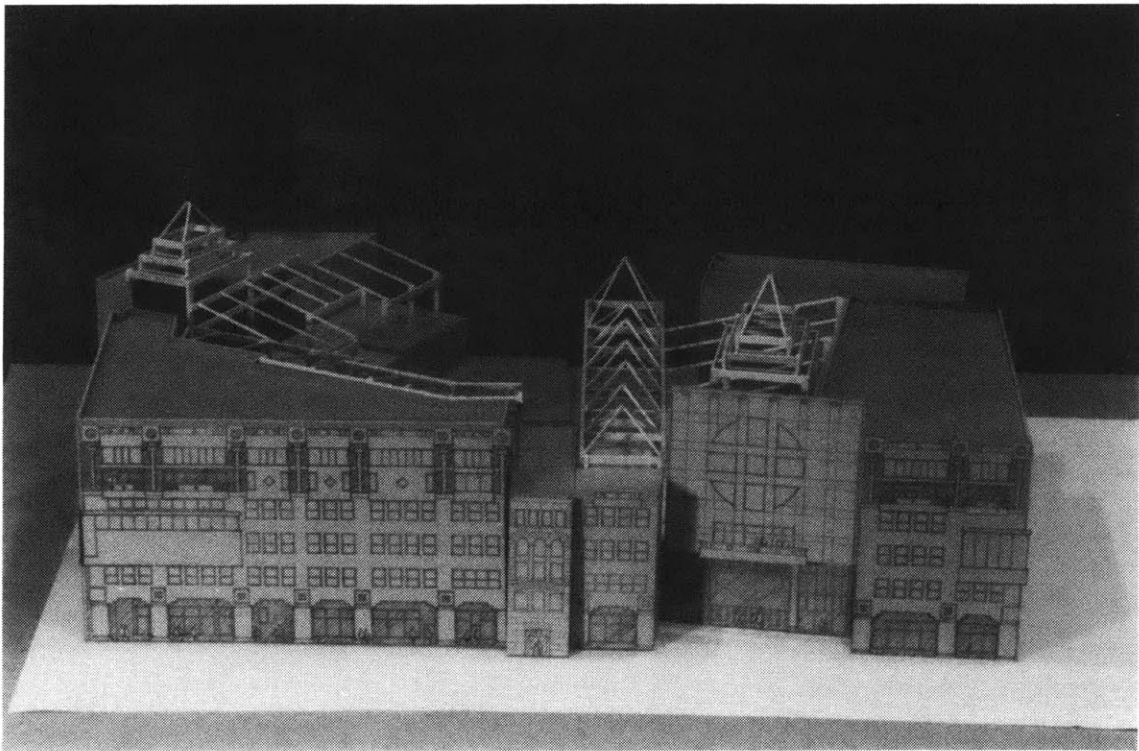
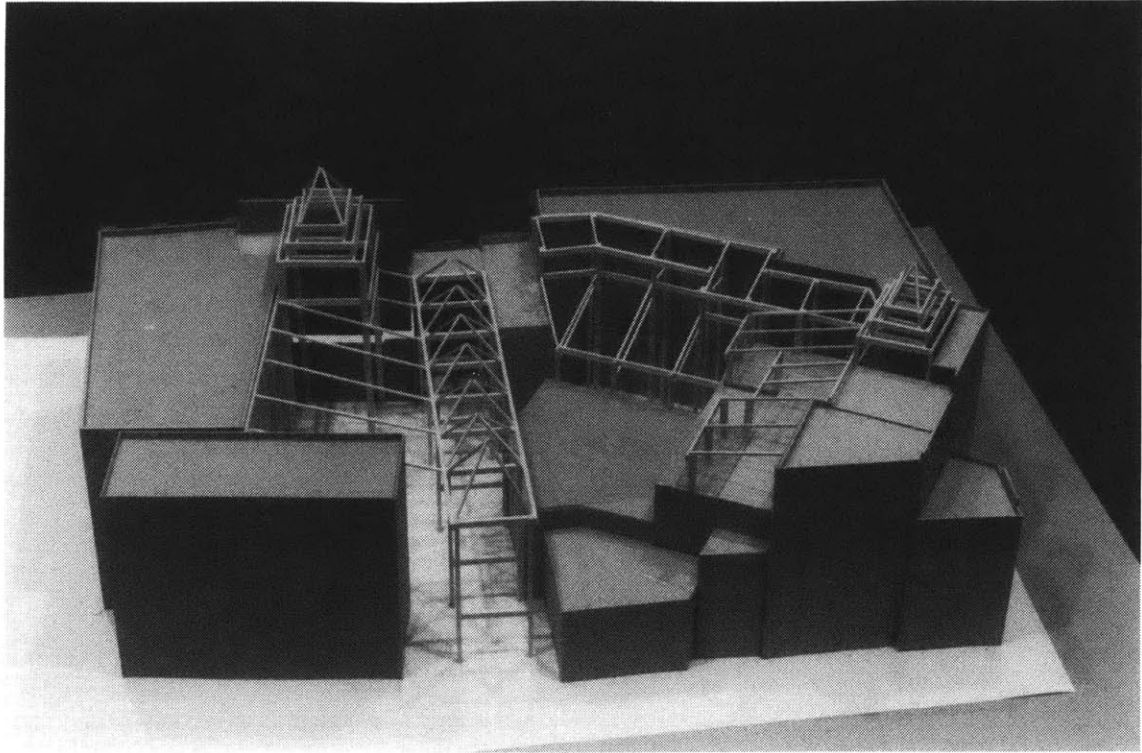
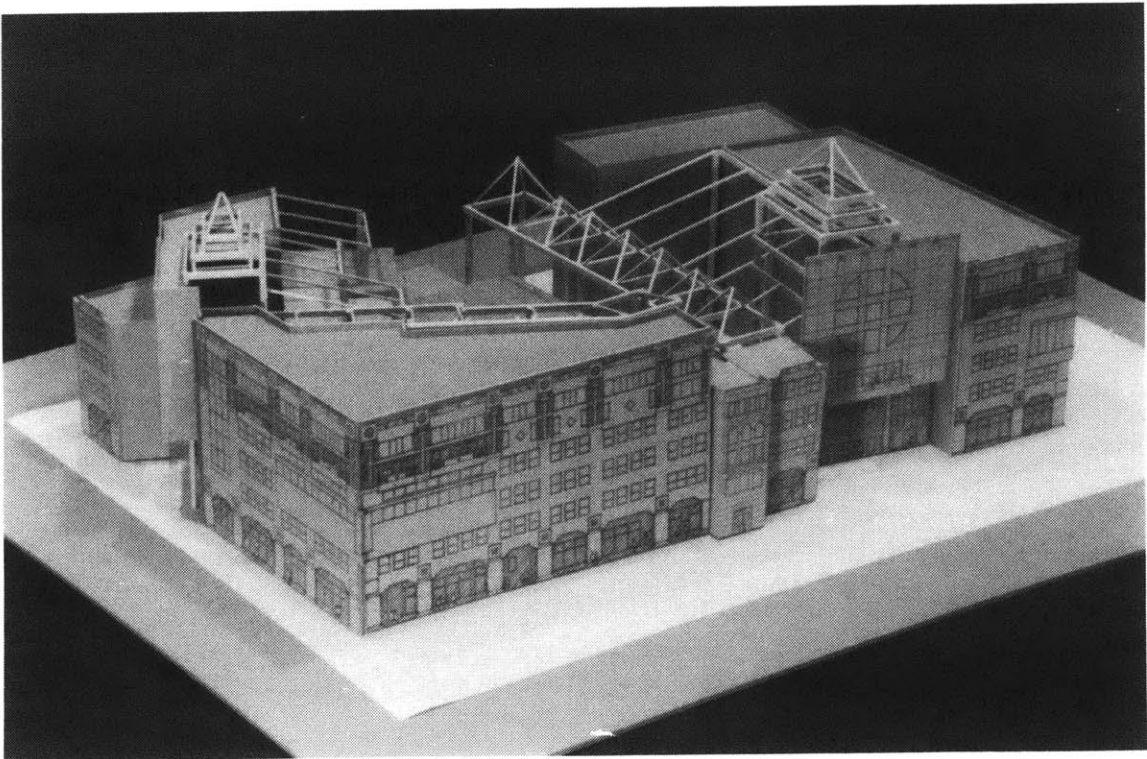
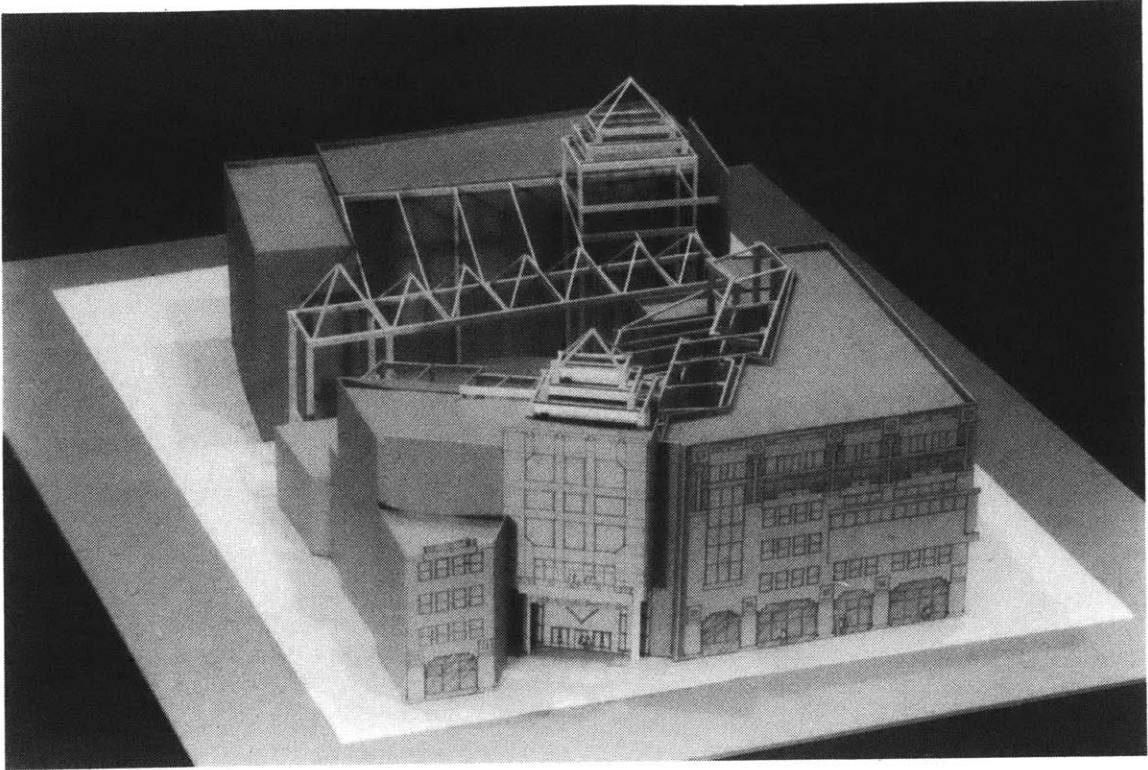

Fig. 6.26
MODEL PHOTO
A photocopy of the south facade is pasted up to study
the elevation composition.

Fig. 6.27
Study of the building corner.



EPILOGUE

During the thesis research preparation, I found it extremely frustrating to try to derive a contemporary Chinese architectural language. The more I read about traditional Chinese architecture, the more I realize why so many architects have given up on integrating Chinese personality into modern architecture; and even when some architects attempt to do so, they do it too literally.

The difficulty I have found is that everything we inherit from the traditional Chinese architecture including the form, the material and the spatial arrangements, are obviously no longer appropriate in the today's new society. Also, the transformation of old forms into new ones is not an easy task: it involves a basic understanding of the traditional form before abstracting it into a new one; and the outcome might still be too literal.

At one point I almost gave up the idea of "transformation" and just designed a modern building to fit into the Boston context. But the commitment to do contemporary architecture with the appropriate "Chineseness" kept ticking in my heart. And I moved on. The breakthrough came when the concept of "Chinese garden path" emerged, which later on became one of the elements in the metaphor of the "Chinses Garden". This concept gave me the motivation to carry on, to search for more "cultural vocabularies".

The concepts and elements applied in my design become the "cultural vocabularies" which are the components of a Chinese architectural language. There are many other cultural vocabularies that need to be uncovered and applied by architects who share my point of view concerning contemporary Chinese architecture.

This academic exploration is over. But the hope for continuity of Chinese architecture through the use of a contemporary language derived from our roots, is all but over. And my resolution to contribute to Chinese architecture lives on.

And one day I would stand on the land of China and contribute my part to reclaim the lost Chinese architecture direction.

BIBLIOGRAPHY

BOOKS / MAGAZINES

Ancient Chinese Architecture, compiled by Chinese Academy of Architecture, China Building Industry Press, Beijing, 1979.

"China" *Space Society* No. 34, 1984, pp. 83-133.

Chinatown., The Boston 200 Corporation, 1976.

Historic Chinese Architecture Department of Architecture, Qinghua University, 1985. Qinghua University Press, Qinghwayuen, Beijing.

"A conversation with I.M. Pei" *Hong Kong Building Journal* June 1985. pp. 47 -51.

Beeby, Thomas H. "The Grammar of Ornament/ Ornament as Grammar" *VIA III University of Pennsylvania Journal*.

Chang, T.E. 張道一. "中國古代圖案選" 江蘇美術出版社1979.

Chen, Cong Zhou. *On Chinese Garden*, Tongji University Press, Shanghai, China.

Chen, Cong Zhou. *The Gardens of Yangzhou* "揚州園林" 上海發行社 1983.

Ching, Francis D.K. *Architecture: Form, Space and Order*, Van Nostrand, Reinhold Co., New York, 1979.

Crippa, Maria Antonietta. *Carlo Scarpa: Theory Design Projects*, MIT Press, Cambridge, Ma., 1986.

Dechiara, Joseph & Callender, John. *Time-saver Standards for Building Types* Chapter three - Cultural. pp 327 - 392.

Eisenman, Peter. "The Futility of Objects: Decomposition and the Process of Different" , *Harvard Architecture Review*, MIT Press, 1984.

Frampton, Kenneth. "Critical Regionalism", *Perspecta* 20

Hoving, Thomas. "More than a hotel - Fragrant Hill Hotel", *Connoisseur* , Feb 1982., pp. 68 -81.

"Hertzberger's Variation", *Architectural Review*, Feb 1980.

Hunter, Sam. *Isamu Noguchi*, Abbeville Press, Inc. Publishers, New York.

Isamu Noguchi. *Space of 'Akari & Stone*, Chronicle Books, 1986.

Lee, W.W. *Cathay's Idea - Design Theory of Chinese Classical Architecture*, "華夏意匠" 龍田出版社

Liang, Ssu-Chieng. *A Pictorial History of Chinese Architecture* MIT Press. Cambridge, Ma. 1984.

Lim, N. 林若. "老北京店鋪的招中見" 博友出版 1987

Liu, C.P. 劉致平. "中國建築類型及結構" 中國建築社 1987

Liu, O.C. 劉致煥. *Soochow Gardens*, "蘇州古典園林" Chinal Building Industry Press, 1978. 南京工學院建築系

Morris, Edwin T. *The Gardens of China History: Art and Meanings*, Charles Scribner's Sons, New York, 1983.

Norberg-Schulz, Christian. *Existence, Space and Architecture*, Praeger, New York & Studio, 1971.

Owen, Christopher. "Fragrant Hill Hotel" AIA Architecture Journal

Pang, E.G. 彭一剛. "中國古典園林分析" 中國建築社 1986.

Pena, William. *Problem seeking: an Architectural Programming Primer*, Cahners Books International, Inc., Boston, 1977.

Southworth, Susan and Michael. *A.I.A. Guide to Boston, The Globe*, Pequot Press, Conn. 1984.

Steinhardt, N.S. *Chinese Traditional Architecture*, Chinese Institute in America, Inc., 1984.

Summerson, Sir John. "What is Ornament and What Is Not" VIA III *University of Pennsylvania Journal*.

Treib, Marc. "Fujisawa Municipal Gymnasium" *Progressive Architecture* June 1985, pg. 72 -80.

Wong, S.F. (translator) "An interview with I.M. Pei" *Chien Chu Hsueh Pao* June 1985 pg. 62-67.

Woodbridge, Sally. "Urban helix", *Progressive Architecture*, April, 1962.

THESIS

Baker, Stephen D. *When Metaphors Speak: A Design for a Theater in Boston*, MIT M.Arch. 1984.

Liu, Chun Wan. *Boston Chinatown - Housing & Land Development* MIT M.C.P. 1979.

REPORTS / NEWSPAPERS

Chinatown - A Report Prepared for CEDC MIT Total Studio, May 1977.

Gambon, J. "Survey Shows Overcrowding, Rats, as Major Problems in Chinatown", *Boston Globe*.

Garvin, Andrew. *A Brief History of Boston Chinatown*, 1987.

Hart, Jordana. "For Art's Sake: Proposals for Cultural District", *Tab*, March 15, 1988 vol.8. No.28.

King, John. "The Combat Zone's Last Stand?" *Boston Sunday Globe* Nov 22, 1987. pg. A43, A44.

Meyers, Jack. "Chinatown Fights Hospital Move", *Boston Sunday Herald*, Dec. 6, 1987.

Shaw, John. "Moving Toward a Plan", *Asian Insight*, vol.1 No.6, Dec 1987.

Wong, Doris & Radin. C.A. "Chinatown is at a Crossroads" *Boston Sunday Globe* Aug 2, 1987. pg. 1, 22, 23.

