

**Design for Implementation: Fully Integrated Charging & Docking Infrastructure
Used in Mobility-on-Demand Electric Vehicle Fleets**

by

Jean Mario Nations Martin

Submitted to the
Department of Mechanical Engineering
In Partial Fulfillment of the Requirements for the Degree of

Bachelor of Science

at the

Massachusetts Institute of Technology

June 2012

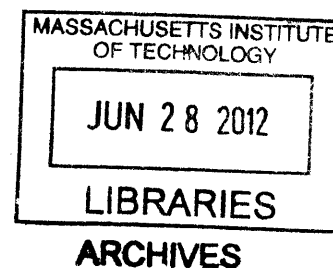

© 2012 Massachusetts Institute of Technology
All rights reserved

The author hereby grants to MIT permission to reproduce and to distribute publicly paper and electronic copies of this thesis document in whole or in part in any medium now known or hereafter created.

Signature of Author _____

Handwritten signature of the author, Jean Mario Nations Martin, written in black ink.

Department of Mechanical Engineering
May 30, 2012

Certified by _____

Handwritten signature of Warren Seering, written in black ink.

Warren Seering
Professor of Mechanical Engineering
Thesis Supervisor

Accepted by _____

Handwritten signature of John H. Lienhard V, written in black ink and enclosed in a large, hand-drawn oval.

John H. Lienhard V
Collins Professor of Mechanical Engineering
Chairman, Undergraduate Thesis Committee

Design for Implementation: Fully Integrated Charging & Docking Infrastructure Used in Mobility-on-Demand Electric Vehicle Fleets

by

Jean Mario Nations Martin

Submitted to the Department of Mechanical Engineering on May 25, 2012
In Partial Fulfillment of the Requirements for the Degree of
Bachelor of Science in Mechanical Engineering

Abstract

As the technology used in electric vehicles continues to advance, there is an increased demand for urban-appropriate electric charging stations emphasizing a modern user interface, robust design, and reliable functionality. Publicly shared transportation systems provide electric vehicles with further synergies by allowing for less energy consumption per capita and decreased car congestion. Unfortunately, existing charging platforms are not designed for proper adoption in a public setting and tend to be vulnerable to potential safety hazards and vandalism. Our product, smartCharge, addresses the need for electric charging in a Mobility-on-Demand transportation system. The connector interface design proposed allows for a modular approach for charging various publicly shared electric vehicles, while using a current-controlled locking mechanism with up to 250 pounds of force. Additionally, the connector is linked to the charging post through a stainless steel retractable arm, which is composed of a spring-loaded pulley mechanism. This paper discusses the design and manufacturing processes for the charging connector and retractable arm, while elaborating on the overall functionality of smartCharge. Finally, the implementation strategy and key considerations for deploying this technology are briefly discussed.

Thesis Supervisor: Warren Seering
Title: Professor

Acknowledgements

First of all, I would like to thank Praveen Subramani, who oversaw and coordinated the smartCharge design project. His inputs and contribution during the development of the charging connector were invaluable. I also wanted to thank Guangyan Gao and Sean Cockey, who focused on the retractable arm and internal electric system of the charging station, respectively.

Special thank you to my thesis supervisor, Mechanical Engineering Professor Warren Seering, whose advice and mentorship were essential throughout the semester. His guidance was important in helping me develop a strategy for completing the project successfully.

Table of Contents

1. Introduction	8
2. Background.....	12
2.1 Mobility-on-Demand.....	12
2.2 Electric Vehicles.....	13
2.3 MIT City Car.....	16
2.4 Existing Charging Infrastructure for Electric Vehicles.....	19
3. The Case for smartCharge.....	21
3.1 Critical System Features.....	21
3.2 The Need for Asymmetric Dynamic Pricing.....	23
3.3 Coordinating Electricity Demand and Available Capacity.....	25
4. The connector interface.....	28
4.1 Copper rings and axial symmetry.....	28
4.2 Connector pins.....	30
4.3 PCB and wooden boards.....	32
4.4 The locking mechanism.....	33
4.5 Internal wiring features and weight determination.....	35
4.6 External features and user considerations.....	36
4.7 Finalized male and female connectors.....	37
5. Testing and Future Work.....	38
6. Implementation Strategy for smartCharge.....	43
6.1 Station placement.....	43
6.2 Electricity source and off-peak charging.....	47
6.3 Local culture, policy implications and strategy.....	49
7. Conclusion.....	52
8. References.....	54

List of Figures

Figure 1: Boston Hubway docking station.....	13
Figure 2: Carbon dioxide emission forecast for New York City, and associated predicted cuts by category.....	15
Figure 3: Carbon dioxide emissions per mile for vehicles with different energy technologies	16
Figure 4: Conceptual image of the MIT City Car.....	17
Figure 5: City Car and its enhanced parking space	18
Figure 6: Existing charging stations for electric cars.....	19
Figure 7: Fabricated and fully assembled final prototype of smartCharge	21
Figure 8: Papanikolaou's schematic representation of asymmetric dynamic pricing for pick-up and drop-off. The Blue line represents the path of highest pay-off for a given user.....	24
Figure 9: Effect of smart, off-peak charging for EV implementation in NYC.....	26
Figure 10: Schematic representation of electric connection interface for SmartCharge	28
Figure 11: Fabrication process for the concentric circular copper rings used in the electric link between the male and female connectors.....	29
Figure 12: Male connector's spring-loaded metal pins and PCB board. Front view (left) and back view with the concentric copper rings (right)	30
Figure 13: PCB board with mounted copper rings and slots for connector pins.....	31
Figure 14: Male/Female electric connection interface with spring-loaded pins 3D-modeled at mid-stroke for minimizing assembly mismatch.....	33
Figure 15: Internal features of male connector, and four slots for wiring the copper rings in the female connector	35
Figure 16: 3D-printing fabrication process for the male connector handle.....	36
Figure 17: Schematic view of male (top) and female (bottom) charging connectors.....	37
Figure 18: Female connector (left) and inserted male charger (right) with locking mechanism activated.....	38

Figure 19: State-of-charge lighting pattern for smartCharge.....39

Figure 20: Internal electrical system and pulley for retractable arm.....40

Figure 21: Population density map of Boston44

Figure 22: Sources of electricity in Massachusetts47

Figure 23: Load per hour in New England48

1. Introduction

Recent technology advancements in the underlying technology for deploying electric vehicles in major cities across the globe have intensified the demand for reliable, urban-appropriate charging infrastructure. More specifically, recent progress in publicly shared systems for electric vehicles greatly increases the need for convenient electric power. The Changing Places Group at the Media Lab has been developing a compact electric vehicle to be used through a Mobility-on-Demand platform. Advantages of using electric vehicles in a publicly shared system tailored toward personal mobility include decreased greenhouse gas emission, reduced congestion, and improved usage of local energy resources.

There has been an increasing deployment of multiple types of electric vehicles, including scooters and cars of different scales, in highly dense urban environments. Current charging technologies, however, have not effectively addressed this growing demand when applicable to vehicles of various sizes and forms. For this reason, it is important to engineer a flexible charging infrastructure that could potentially be used for many different mobility approaches. Given a trend towards smaller and lighter vehicles such as electric scooters, it is also critical to create new minimally intrusive technical solutions that address charging as well as docking/locking for electric vehicles. Unfortunately, existing charging infrastructure products tend to resemble the design features encountered in traditional gas pumps. These systems expose users to many potential hazards, such as tripping on the long cables, experiencing an electric shock due to cut rubber cables running from the charging post to the connector, or having their vehicles stolen or unplugged from the station.

Electric vehicles deployed using a Mobility-on-Demand solution will play an important role in meeting future city or state-level carbon dioxide emission cuts. The goal of this project was to develop a new publicly shared charging station that is appropriate for highly dense urban environments and also contains an effective docking/locking capability. Our solution includes a connector interface that allows for radial symmetry (more user friendly) and locks the vehicle in place using a current-controlled magnet system. Additionally, the charging station makes use of a custom-made retractable arm, which provides great flexibility for charging various vehicles while minimizing vulnerability to potential vandalism with a robust stainless steel encasing. This arm contains all the required wiring that runs from the charging post to the male connector interface. The prototype presented in this paper allows for enhanced user experience by adopting a personalized identification and payment processing system that could be coordinated by a central command center in a given city.

There are various benefits associated with the implementation of our design in a publicly shared Mobility-on-Demand transportation system. The project's environmental and energy benefits can be increased over time as more renewable generation is integrated into the grid. Additionally, since a common concern for mass-scale adoption of electric cars entails the insufficient grid capacity for an increased electricity demand, a publicly shared charging infrastructure could more easily coordinate charging during off-peak hours, thus leveling off the grid electricity supply. A more leveled load curve would lead to decreased energy losses, thus saving the city money and electricity, while not requiring an increased grid capacity. Over time, as battery technologies continue to develop, it would be possible to integrate the publicly shared charging infrastructure with

a smart grid that could buy and sell electricity from and to electric vehicles. This would further help coordinate the dynamic electricity demand throughout the day.

We believe that a publicly owned electric vehicle system would facilitate the coordination of capital investment towards the automobiles as well as the underlying charging infrastructure, thus minimizing the financial risk associated with the high initial capital investment. Taking into account existing federal grants for private electric vehicles, individual U.S. city governments could consider a first fleet of vehicles and charging infrastructure without bearing the entire initial financial commitment. Most policy implications would happen at the local level, since the city government would undertake part of the initial financial burden and also lead the adequate implementation plan.

For this project, I worked with a group of two undergraduates and one graduate student (please refer to Acknowledgements section for more detail). Although our team developed the entire electric and mechanical infrastructure of the proposed charging station, my engineering responsibilities were entirely focused on the design and manufacturing process for the female/male connector interface and electronic locking mechanism. I was in charge of brainstorming, performing 3D-models for the design, testing and improving the connector interface. The graduate student team leader, Praveen Subramani, oversaw the design and prototyping for all subsystems of the charging station. In addition, I also participated in the design process for the retractable stainless steel arm linking the charging post to the locking connector. Based on a series of user-testing interactions, potential design problems and future improvements were briefly discussed.

Finally, I performed extensive research on key implementation logistics and considerations for deploying this proposed charging technology using a Mobility-on-Demand transportation system. In the implementation portion of this paper, I elaborate on important aspects for determining strategic charging station locations, while utilizing the publicly shared nature of our product to address potential pitfalls generally associated with electric vehicles adoption and maximize the utility provided by our charging solution.

2. Background

2.1 Mobility-on-Demand

Mobility-on-Demand (MoD) is a new concept in transportation that personal mobility can be thought of as a utility service, just like heat, water or electricity. MoD systems are publicly shared, allowing users to temporarily borrow a vehicle to go from one point in a dense urban environment to another. Instead of undertaking the financial investment to own a private vehicle, users of a MoD system pay for their personal mobility based on their immediate needs. It is generally believed that, since the initial cost of car ownership is switched to an increased marginal cost of transportation, MoD systems cause users to drive more efficiently, thus reducing average per-capita travel time and, in the case of automobiles, the amount of fuel or electric energy consumed. MoD systems allow for a similar functionality as personal vehicles while using fewer automobiles, thus reducing congestion, energy consumption and carbon emission.

MoD systems have been increasingly gaining presence in many cities around the world. These systems come in various forms, including shared bicycles, electric cars and scooters. In France, the adoption of Velib, a system of publicly shared bicycles, has spurred a more effective and less energy-intensive mobility system. Similarly, the Boston Hubway program represents another attempt to use MoD as a way to support a cleaner, healthier and more properly structured approach to transportation. The city of Boston currently has a total of 600 bicycles available in 30-minute intervals to individuals who pay a monthly fee. Currently, the Hubway program has installed 60 stations spread across Boston.¹

Because of reduced travel time and more efficient use of cars, MoD systems are believed to decrease the total number of vehicles in a given urban environment. According to a study conducted by Zipcar, one publicly shared vehicle in a city serves the function of 20 privately owned vehicles. Another study by the MIT Media Lab indicates that this ratio is closer to one public automobile to every seven private cars. Regardless of the specific ratio, the scientific community generally agrees that MoD systems in dense urban settings would lead to fewer total vehicles, thus allowing for less pollution, street congestion, and energy consumption.^{2,3}



Figure 1: Boston Hubway docking station

2.2 Electric Vehicles

Over the past decade, electric vehicles (EVs) have gained considerable popularity in the United States. In 2009, American manufacturers announced more than a dozen highway-capable electric car models for introduction between 2011 and 2012. These models mostly come in three forms: plug-in hybrids (GM Chevy Volt), compact

electric car (Mitsubishi i-MiEV), and full-range electric cars (Tesla Model S). In parallel with this widespread private initiative, the Federal Government has also made aggressive moves to support the adoption of electric transportation in the United States. More specifically, the Obama administration set a goal of ensuring that more than one million plug-in hybrids will be put on the road by 2015. Additionally, the government allocated approximately \$4 billion to the design, manufacture and purchase of plug-in hybrids. In 2008-09, the US Department of Energy solicited \$2.4 billion in federal funding to invest in EV battery and drive-train technology, as well as transportation electrification demonstration initiatives. Finally, the federal government has created a tax subsidy of up to \$7,500 per vehicle to minimize the financial burden associated with the relatively high price of electric vehicles.^{4,5}

Apart from the desire to decrease dependence on oil imports, the major driver for these recent private and public initiatives to promote the research and adoption of electrically powered automobiles is the potential for decreased pollution levels and greenhouse gas emissions. According to a study conducted by McKinsey & Company, the adoption of EVs at 14-15% of all automobiles in New York City will contribute to a relative decrease of 6.1 million tons per year by 2030 in the city's transportation carbon dioxide emissions. The numbers below represent the target goals based on PlaNYC, the major sustainability plan for the city of New York. Although sustainable transportation will be the fourth most effective way to reduce the city's projected carbon dioxide emissions, it still plays a critical role in ensuring that the target goal is properly met. This study predicts that sustainable transportation will contribute to more than 12.5% of all emission reductions, thus making adoption of electric vehicles a necessary

consideration for local policy-makers.

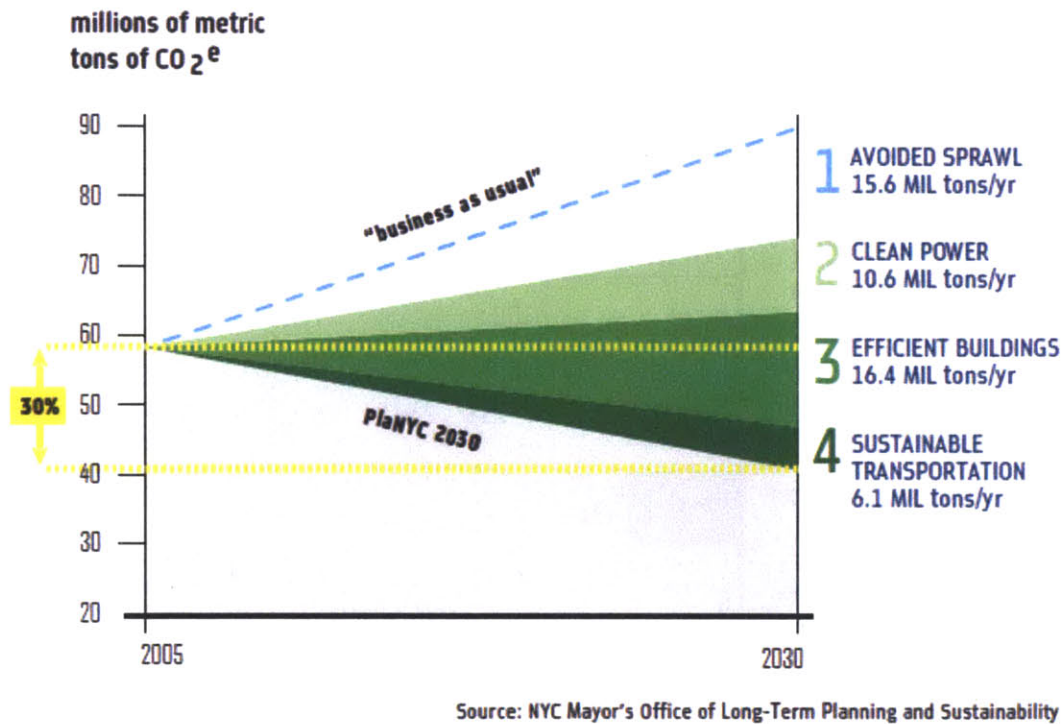
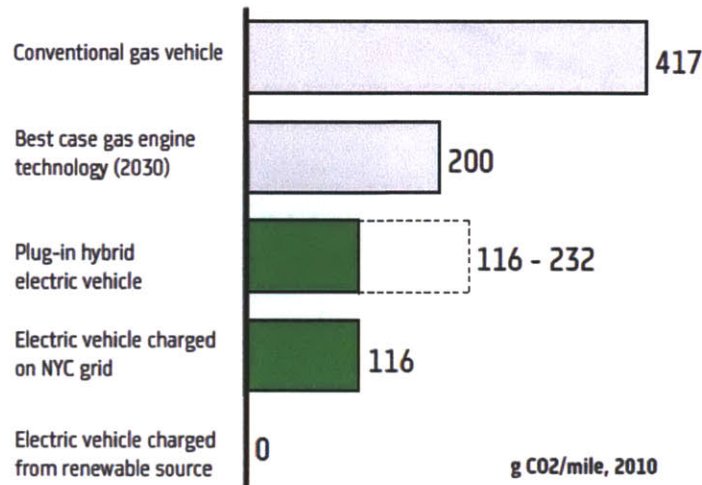

Figure 2: Carbon dioxide emission forecast for New York City, and associated predicted cuts by category

A considerable part of the environmental benefits inherited from the adoption of electric vehicles, instead of gasoline-powered automobiles, depends on the source of electricity used to charge the EVs.⁶ For example, if the source of electricity used to charge the electric vehicles is renewable, then all the marginal carbon dioxide emission level (not associated with manufacturing of the vehicles) would be reduced to zero. However, renewable energy generally only constitutes a small percentage of a city's electricity generation. In the case of NYC, the high hydro-based electricity generation makes electric vehicles especially appealing from an environmental perspective. The image below depicts the wheel-to-well emission comparison for combustion engine and

electric driving in NYC. Based on the data provided, it can be concluded that EV adoption in the city, even without using entirely renewable energy, would lead to approximately 72% less carbon dioxide emissions for each electric vehicle.



Source: IEA, IAEA, AG Energiebilanzen, U.S. Dept. of Energy, McKinsey, Oak Ridge National Laboratory

Figure 3: Carbon dioxide emissions per mile for vehicles with different energy technologies

Although electric vehicles require a greater electricity grid capacity in a large urban environment, they can effectively contribute to a considerable reduction in greenhouse gas emissions if properly implemented. Recent trends both in the private market and in public policy have been further improving the competitiveness of EV technology. As time progresses, it is likely that electric vehicles will become increasingly more popular as a transportation strategy.

2.3 MIT City Car

Over the past few years, researchers from the MIT Media Lab have been developing a new generation of small scale EVs that will redefine how users think about

personal mobility. By integrating aspects of both Mobility-on-Demand systems and existing electric vehicles, the MIT City Car (See Figure 4) offers a transportation alternative that is considerably cleaner and consumes less energy. The vehicle was designed to be used in a MoD system, where registered users pay to pick up a car at a given parking station and drop it off at a different location in the city. In addition to the advantages that other MoD systems have, City Cars also achieve high energy efficiency due to their lightweight and compact design. The City Car has the same environmental and energy benefits as typical electric vehicles, and each charge allows a trip of over 100 km (62 miles), making it practical for in-city travel.

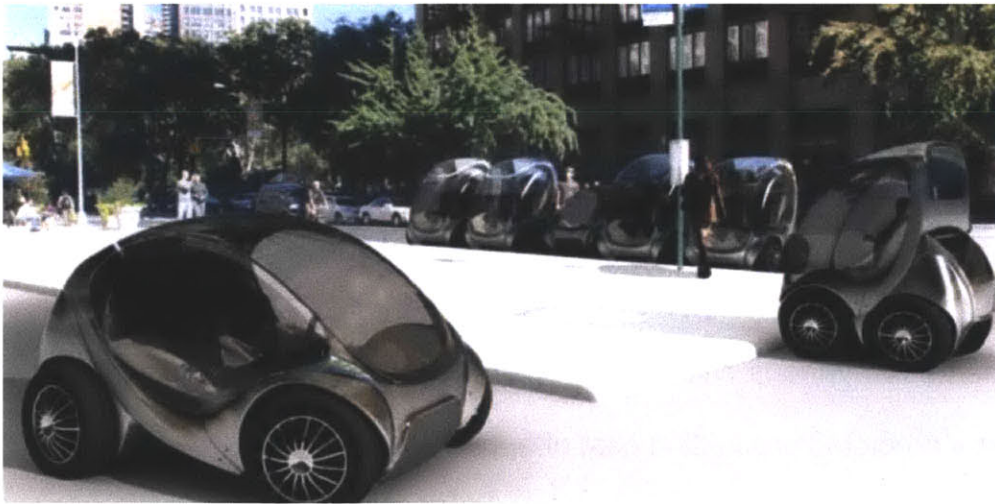

Figure 4: Conceptual image of the MIT City Car

The vehicle is electrically powered with a 3.75kW motor installed at each of its four fully autonomous wheels. These independent robotic wheels allow for greater maneuverability, permitting the user to park in much tighter spaces. Additionally, an innovative folding design allows three parked City Cars to take up the same amount of

space as one SUV (See Figure 5). City Car is therefore more valuable than existing electric vehicles because its MoD approach reduces congestion and travel time while enhancing existing parking space in dense urban environments.

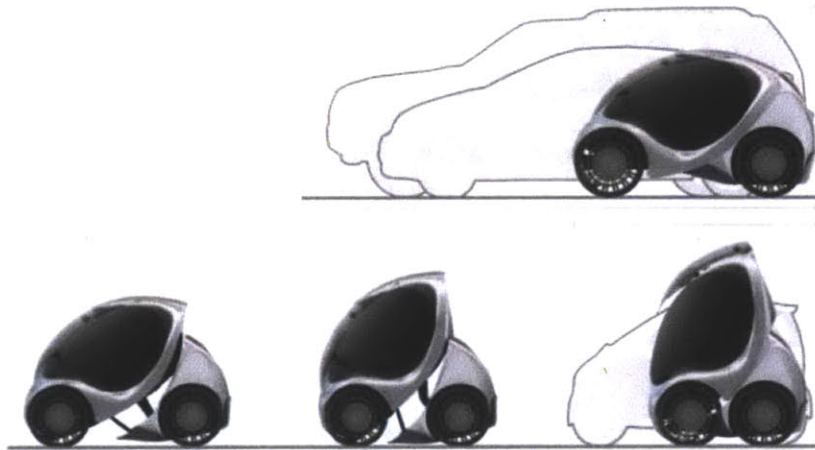

Figure 5: City Car and its enhanced parking space

In order to make the City Car a reality, the MIT Media Lab has partnered with Spanish firms to manufacture a commercial version of the vehicle, known as Hiriko, to be implemented in various cities in Europe. The first produced Hiriko will be deployed this year at a predicted production cost of approximately \$16,000 per vehicle.⁷

This thesis proposes that the MIT City Car is a fitting and practical way to improve Boston from a transportation perspective. It can reduce the city's traffic congestion, pollution, and energy use while improving the city's transportation efficiency and its reputation as a hub for technological and social innovation. In order to argue for its adoption, this thesis will put forth a plan for implementing the system, the advantages and disadvantages of implementing it, and thus a demonstration that the benefits far outweigh any negative effect.

2.4 Existing charging infrastructure for electric vehicles

Despite the fast-paced innovation that has recently spurred the development of improved electric vehicle technology, much is lacking in the current charging stations dominating the market. Most systems highly resemble a regular gas pump, using a rubber or plastic chord that runs from the charging post to the male connector.



Figure 6: Existing charging stations for electric cars

Such designs inherently have various hazard issues associated with their deployment in a public urban environment. For example, these free chords can easily be left on the floor, thus creating potential problems with tripping or tangling with vehicles. The choice of material also makes these stations fairly vulnerable to public vandalism, since any individual could relatively easily cut the linking chord, thus exposing a very large voltage to anyone who is walking nearby. Additionally, current charging infrastructures for electric vehicles are not designed to cope with Mobility-on-Demand transportation systems. Publicly shared mobility platforms using electric

vehicles would require an integrated smart system that can track users and their temporary vehicles via some sort of electronic identification. This would be essential in the payment processing, as well as in monitoring any potential damaged or misplaced vehicle. Finally, given a recent trend towards deployment of smaller, lighter electric vehicles such as scooters and hybrid mechanical-electric bicycles, it is critical that charging technology adopted in these systems contain some sort of locking or docking feature without severely affecting the public space. Unfortunately, no existing design incorporates these critical functionalities.⁸

3. The case for smartCharge

3.1 Critical system features

The objective of this project was to develop a charging station that addressed the concerns discussed in the previous section and to provide a complete platform that could be quickly implemented in a MoD transportation system utilizing electric vehicles. As mentioned previously Praveen Subramani, current graduate student at the MIT Media Laboratory, was in charge of leading the design of the charging station. My engineering focus was developing the female and male connector interface, as well as assist with the design of the retractable arm linking the connector to the post.

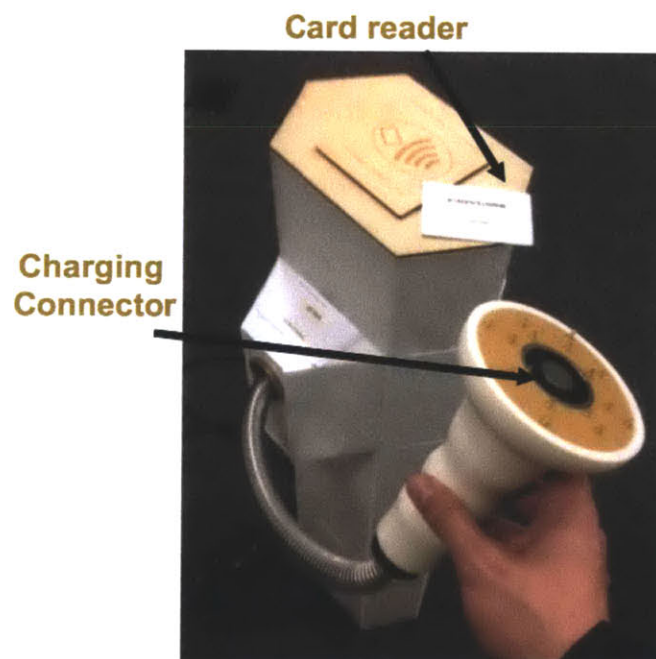

Figure 7: Fabricated and fully assembled final prototype of smartCharge

Our proposed design includes a user-friendly connector that contains an integrated charging and locking functionality. The male connector is attached to the

station through a stainless steel arm encasing internal wires. This retractable arm is spring-loaded and fed in and out of the station using a vertical pulley internal mechanism. Since the arm is flexible and extendable, this feature permits charging for vehicles of various sizes as long as a standard female connector is also used. Additionally, the arm provides a more robust solution to protect the charging stations against potential vandalism—it's much harder to cut or break this arm than the rubber or plastic chords of existing charging platforms.

In order to utilize the station, a user would have to be certified and own a personal electronic identification card, with which he or she could activate the charging post by tapping the card onto the electronic reader as shown in Figure 7. Once the user tapped it, the already attached connector would deactivate the current-controlled magnetic locking mechanism, at which point the retractable arm of the station would gently pull back the male connector. Since a personal user ID card is required for the unlocking procedure, the integrated electronic system would be able to readily identify which users have reserved each given vehicle. This would be essential in not only controlling the informal flow and tracking taken vehicles, but also in implementing a more appropriate payment system. By tracking each vehicle and user based on which electronic ID was used to unlock the charging connector, it would be possible to charge users based on both rental time as well as energy consumed. Our product addresses all of these issues by using a centralized, intelligent information-processing tool with a system of electronic IDs for each user.

3.2 The need for asymmetric dynamic pricing

Mismatched supply and demand is a common problem for any MoD system. Because of its one-way pick-up and drop-off feature, after a day of operation the number of vehicles at each station is unlikely to be balanced. Some stations will have a surplus of vehicles, while others will have a shortage. Velib, the large-scale bike sharing system in Paris, attempted to fix this problem by having employees continuously move and redistribute bikes between stations by truck. This method was not as efficient as it could be. In his thesis, Dimitris Papanikolaou suggested dynamic pricing as a more efficient method for fleet management, and this is a strategy that could be adopted with the use of smartCharge. In this method, the price for picking up a vehicle is determined by the relative number of vehicles available at that station compared to other stations. A user can choose to either pick up a vehicle at a popular station close to their location, or walk a few blocks to another station for a reduction in price.⁹

Although the traffic pattern is usually consistent throughout most days, exceptions—such as weekends, holidays, and unexpected shocks— arise fairly often. To ensure that the price at each station always reflects the current demand and supply at that station, the price should be dynamically set after considering all stations involved. To provide familiarity and predictability to frequent users, a price schedule should be available for most days, except during holiday or special occasions where the price should be adjusted real-time. The schematic image below depicts the logistic of using a MoD solution with dynamic pricing.

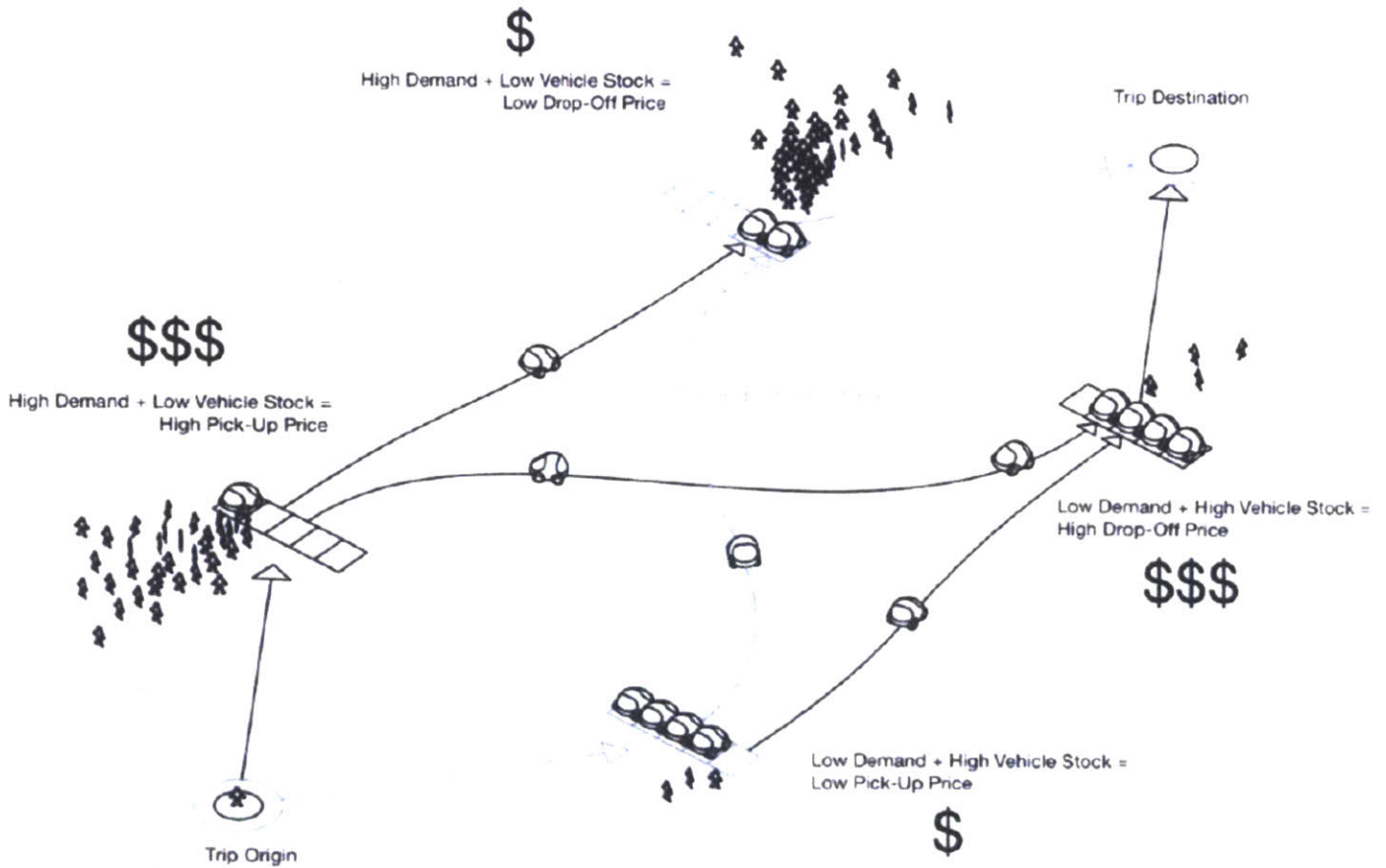

Figure 8: Papanikolaou's schematic representation of asymmetric dynamic pricing for pick-up and drop-off. The Blue line represents the path of highest pay-off for a given user.

Regions with low demand and many parked vehicles have a low pick-up price, while stations with high vehicle demand and low stock have a low drop-off price. Additionally, stations with high demand for vehicles and low stock have a high pick-up price, while regions with low demand and high vehicle stock have a high drop-off price. We believe that using smart charging stations would allow for effective dynamic pricing and improve the problems associated with asymmetric demand. Current charging infrastructure, unfortunately, do not have the supporting technology for dynamically monitoring the demand for and availability of vehicles at each given station. Our

proposed solution could use the electronic ID tapping system, together with a centralized information control system, to accurately determine pick-up and drop-off prices at various locations throughout the day. This sort of information flow and dynamic pricing is an important financial tool for stabilizing the asymmetric location demand at different times.

As this concept of MoD systems for electric vehicles continues to develop and be adopted over time, smartCharge could further improve the user experience by utilizing a real-time phone application in which individuals would know the availability and price of vehicles near their actual location. As they drive in the city, users would have access to constantly updated information on available parking slots and the drop-off price associated with them. This would ensure that these users would effectively change their driving behavior to accommodate for these financial imbalances, thus decreasing the demand imbalance and facilitating the vehicle distribution across regions in a highly dense urban environment.

3.3 Coordinating electricity demand and available capacity

Historically, automobile-based systems and electrical supply systems have operated as entirely separate entities. However, with the electrification of automobiles, it is beneficial to integrate these two systems. An integration of these systems would require a smart electric grid, which attempts to decrease inefficiency as related to power distribution.^{10,11} A current problem electric grids face is called “load leveling.” This term describes the mismatched nature of energy supply and demand. Electric grids often have either idle generating capacity when demand for electricity is low or insufficient

generating capacity when demand is high. The simplest way for electric vehicles to help the grid is to direct recharge time mostly to off-peak hours. We believe that smartCharge would enable this functionality because of its publicly shared approach to personal mobility and electric charging. A major difficulty with preventing charging for privately owned electric vehicles during peak demand hours is that there's no incentive in place to encourage individual owners to charge their EVs during off-peak hours. However, this would be possible with smart charging stations, which would only charge cars during these hours or if they had low battery. This advantage would not present with private EVs, since it is hard to regulate charging time. Electric vehicles could also monitor electricity prices and patterns of electricity usage and thus optimize their recharging patterns based on the data they collect.

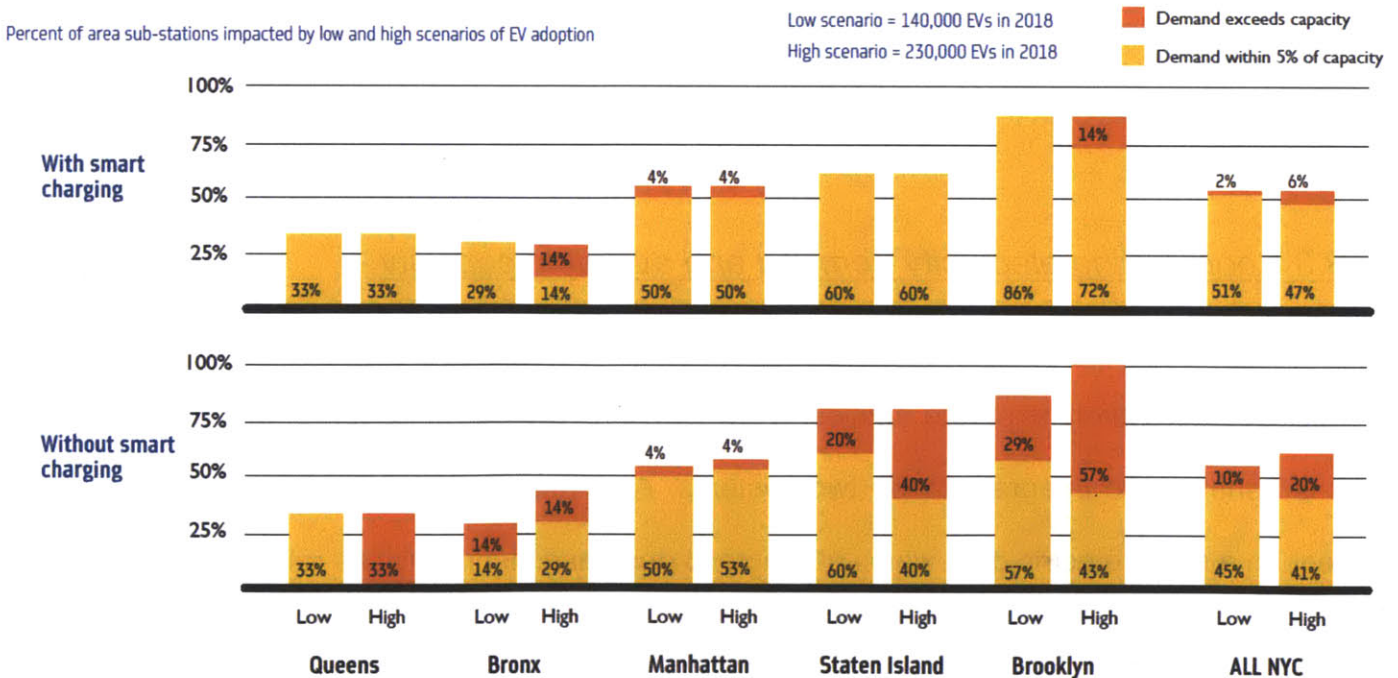

Figure 9: Effect of smart, off-peak charging for EV implementation in NYC

A study conducted by McKinsey & Company in conjunction with the city of New York evaluated how the adoption of EVs of up to 15% of the total number of cars would affect electricity demand in various areas of the city. As the figure above depicts, deploying this quantity of private electric vehicles would lead to an electricity demand that exceeds the available grid capacity. However, with the implementation of some sort of off-peak charging solution, most of the demand would be contained by the available grid capacity. Our product, smartCharge, would provide an improved platform where off-peak charging could be more easily implemented.

Electric vehicles present efficiency and environmental advantages over conventional transportation. It is expected that in the next decade this technology will progressively penetrate the market. The integration of plug-in electric vehicles in electric power systems poses new challenges in terms of regulation and business models. Over the long run, there would be opportunities to formulate more sophisticated business models for vehicle-to-grid applications under which the storage capability of EV batteries is used for providing peak power or frequency regulation to support the power system operation.¹² As smart grid and EV temporary storage becomes a possibility, smartCharge will become an even more appealing platform for charging publicly shared electric vehicles.

4. The connector interface

4.1 Copper rings and axial symmetry

In order to improve the ease of use of the charging station, my design attempts to ensure an axially symmetric connecting interface, where the rotational angle positioning is not required for individuals attempting to charge their vehicles. SmartCharge accomplishes this by using four concentric copper rings for both the female (attached to the car) and male (attached to the charging post) connectors. These copper rings are responsible for the critical feature of establishing a reliable electric connection platform.

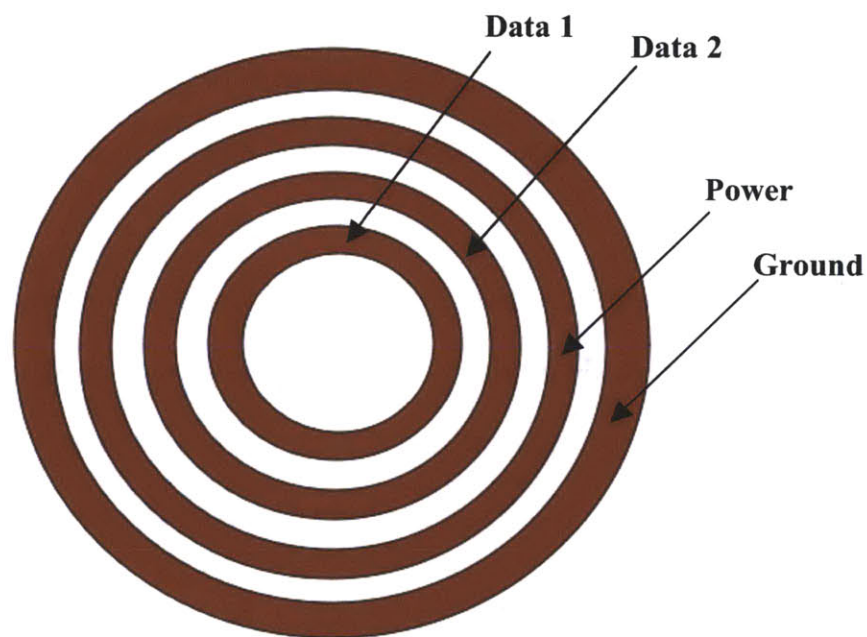

Figure 10: Schematic representation of electric connection interface for SmartCharge

The innermost ring is used for communication going from the charging station to the vehicle. The following ring, referred in the image above as “Data 2”, is responsible for information transfer from the vehicle to the charging station. Finally, the third and

forth (outermost) rings are used for transmitting electric power and establishing a ground connection respectively. In order to prevent shorting problems associated with externalities during the urban usage of these vehicles, small concentric circular extrusions were manufactured between each consecutive copper rings. These circular extrusions are composed of a material that is not electrically conductive, thus effectively managing the risk for shorting the electric circuit. For our initial prototype, the copper rings were manufactured using a waterjet machine with high precision, while the wooden circular extrusions were fabricated with a laser cutter.

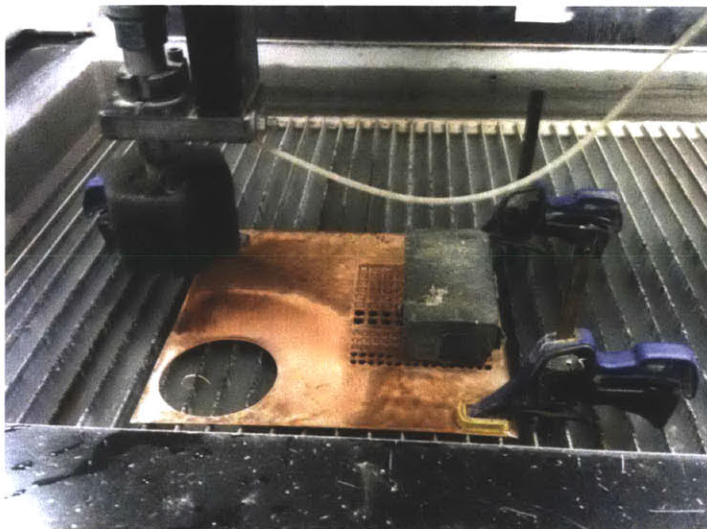

Figure 11: Fabrication process for the concentric circular copper rings used in the electric link between the male and female connectors

4.2 Connector pins

The connection between the male and female copper rings is permitted through small spring-loaded connector pins, which were soldered onto the male copper rings. The decision of using these pins to establish the electric connection was based on similar existing technology for some charging technologies. The adoption of spring-

loaded connector pins was especially important for our design. Due to the manufacturing variance associated with 3D-printing technology, which was used to produce our initial prototype, it was critical to achieve maximum design flexibility for our product during the computer-aided modeling steps.

Designing these pins at mid-stroke (approximately 0.05 inches from the fixed point), it was possible to ensure reliable electric connection despite the relatively high tolerance of our 3D-printing device (approximately ± 0.05 inches). For each copper ring, there are four pins equally spaced from each other at 90 degree intervals. This design feature allows for greater reliability during the charging process. For example, as long as one out of four connector pins for each copper ring touches the female copper ring counterpart the electric connection will be successful. This minimized the risk of poor electric connection due to misalignment or intrinsically inherited manufacturing error.

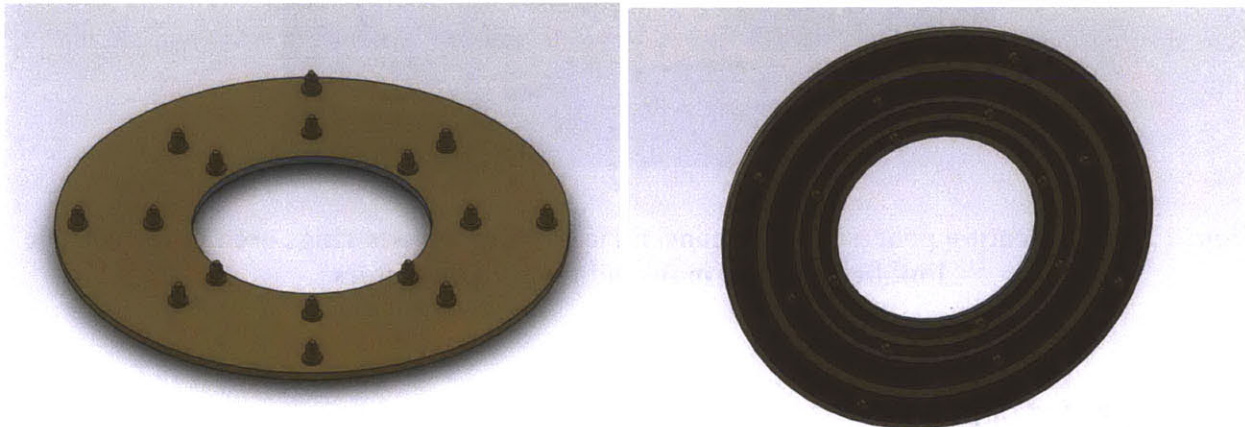

Figure 12: Male connector's spring-loaded metal pins and PCB board. Front view (left) and back view with the concentric copper rings (right)

4.3 PCB and Wooden Boards

The four copper rings for the male and female connectors were attached to a PCB board and wooden supporting structure respectively. These boards were fabricated precisely using 2D laser cutting technology, thus decreasing the manufacturing variability of the connector interface. This was critical during the assembly process because the error propagation associated with having both the external casing and supporting boards produced with 3D-printing material would have caused large error propagation and prevented a smooth assembly. Generally, it is advisable to mate 3D-printed parts with components that have a higher precision in order to adequately account for the tolerance in the 3D-printed material. Finally, the PCB and wooden boards provided a firm platform for wiring the copper rings to the charging station and electric vehicle.

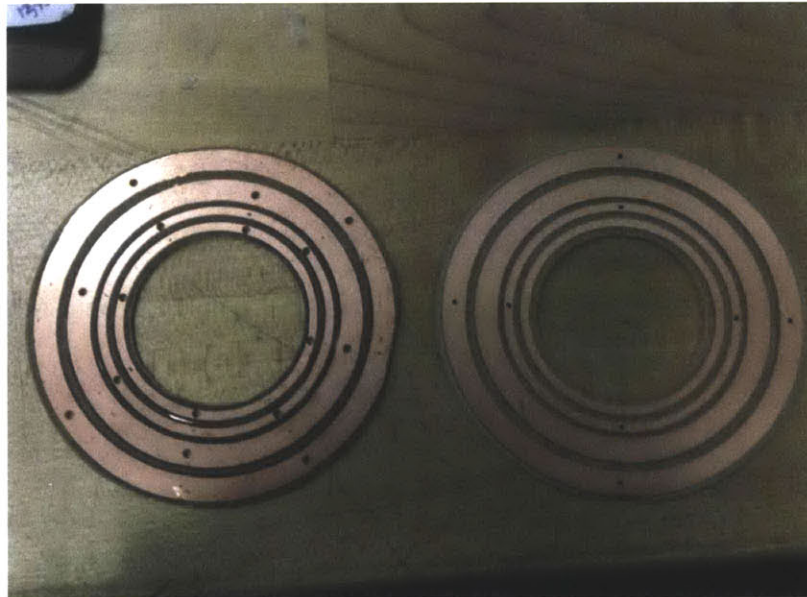

Figure 13: PCB board with mounted copper rings and slots for connector pins

4.4 The Locking Mechanism

As electric vehicles deployed in a Mobility-on-Demand system increasingly gain popularity, the ability to effectively lock a vehicle during the charging procedure becomes even more essential logistically. As explained in the background section, existing charging technology fails to address the need for locking the charging connector to the vehicles. Recent development of various lighter, small-scale electric vehicles, such as scooters and hybrid mechanical-electric bicycles, require integrated charging and docking in order to prevent thefts of the publicly owned transportation devices. Although docking does not provide larger electric cars with more security (theft is not as big of a problem in this case), it still prevents individuals from unplugging the charger from a given vehicle at undesirable times without actually renting the vehicle. This will be critical in order to ensure that users do not “steal” the electric charging time from other individuals, while also minimizing vandalism due the potential removal of the connector during critical charging periods.

In order to achieve a good balance between ensuring the security of the docking feature and maintaining a simple design for the charging infrastructure, smartCharge fully integrates locking and charging capabilities in the connector. Different than the existing Boston Hubway docking stations, which require a relatively bulky approach to lock the bicycles’ wheels, our design allows the charging post to act as the docking technology. This is accomplished through a current-controlled magnetic mechanism, as depicted in the image above. The female connector has a relatively weak permanent magnet that acts as a guiding tool during the manual insertion step. This design feature resembles that of Apple’s MacBook charger, in which a permanent magnet is used for

facilitating the plugging procedure for the laptop. In addition to this guidance-enhancing component, the female connector also has another magnet that maintains full surface contact with the male connector when the charger is mounted in the vehicle. The male connector has a current-controlled magnet that is activated upon insertion of the charger and identification of the vehicle.

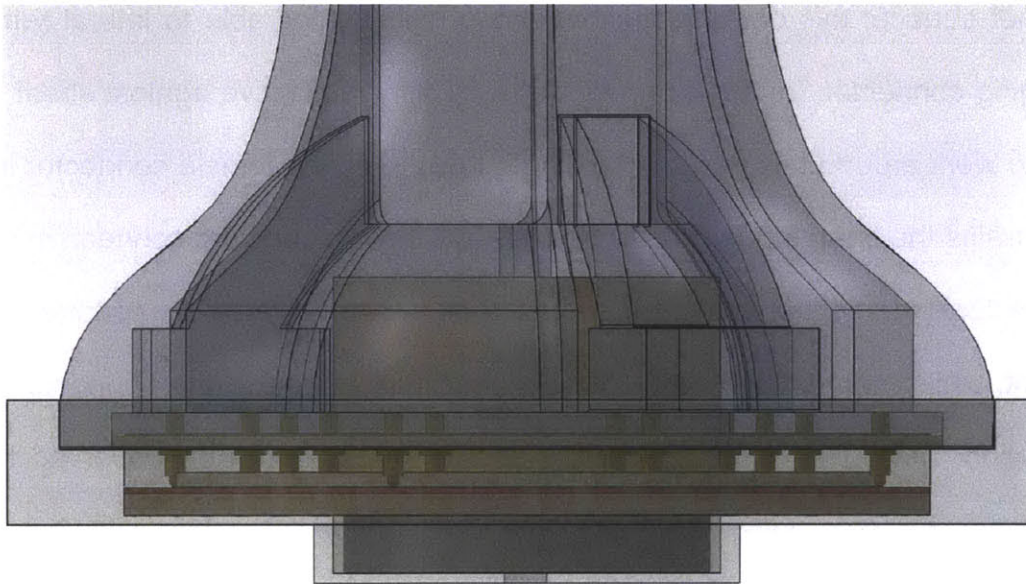

Figure 14: Male/Female electric connection interface with spring-loaded pins 3D-modeled at mid-stroke for minimizing assembly mismatch

Our design minimizes potential electricity hazards (the transmitted current is approximately 36 amps, more than enough to kill a human being) by ensuring that the locking step is realized prior to the initiation of charging. The current-controlled magnet resembles a design feature similar to that used for door locking systems, such as the glass doors for the MIT Media Lab. Currently, the connector locks with approximately 250-300 pounds of force, enough for making it considerably more difficult for the

charging to be inappropriately interrupted through the removal of the charger from a vehicle. Although this is not sufficient to completely lock the charger in place, it is possible to easily scale up this docking force by either supplying more current to the locking mechanism, or simply increasing the size or effectiveness of the magnet chosen.

Although it is possible to achieve a high locking force in the direction normal to the magnet surface, this docking mechanism is highly vulnerable to lateral removal of the charging connector, as the magnetic force is fairly ineffective against shear motion. In order to work around this design challenge, I designed the female connector in a way that constrains the charging handle from sideways motion once the connection is made. Thus, the locking mechanism acts by using a magnetic force to constrain normal movement, while mechanically preventing a user from removing the connector using a shear motion. From the schematic image shown above, it can be observed how the female connector externally constrains the male connector, while allowing enough clearance for ease of insertion manually. Finally, the non-permanent magnet in the male connector is fixed in place using a screw matching its internal threads, thus attaching the magnet directly to the handle.

4.5 Internal wiring features and weight determination

The design process for the male connector required considerations for the essential wiring for the locking magnet and copper rings. In the prototype, as portrayed in the schematic view of the charging connector, three cavities patterned using a circular symmetry were equally spaced at 120 degrees from each other. These cavities

provided access for wires coming from the center of the connector handle to the back of the four copper rings and spring-loaded pins. Additionally, a central cavity was created in the male connector handle to permit the wires for the copper rings and non-permanent magnet to run all the way up to the arm linking the male connector to the charging station. This central cavity also allowed for decreased weight of the male connector, reaching an approximate level that is preferred by users based on current designs of charging connections for electric vehicles. Finally, since the prototype was fabricated using 3D-printing technology, these internal cavities were critical in minimizing the expensive material required for prototyping. For the commercial version of the connector, these cavities would also help decreasing manufacturing costs, but the connector would likely have to be fabricated in two separate halves to obtain the necessary internal features. The female connector also had a more simplified feature for allowing wires to run from the concentric copper rings to the major electricity storage option (battery) in the vehicle.

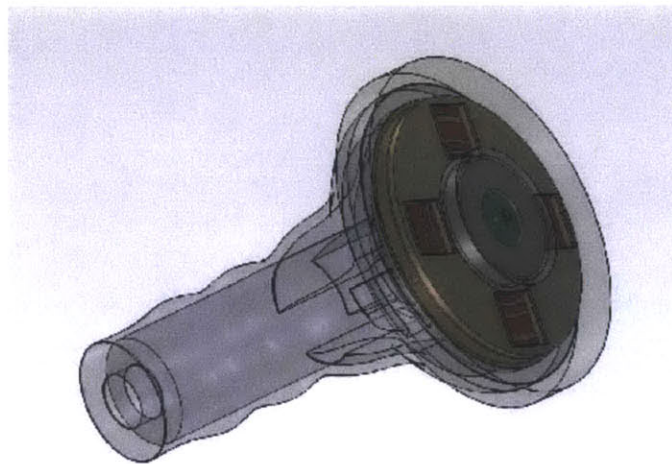

Figure 15: Internal features of male connector, and four slots for wiring the copper rings in the female connector

4.6 External features and user considerations

The handle external design is a critical feature for determining the effectiveness of the proposed prototype from a user's perspective. For this reason, I attempted to account for major required external features while not affecting the overall functionality of the charging connector. The selected handle design was based on critical differentiating aspects of our fully integrated charging and docking solution for electric vehicles. The handle was engineered with a grip that makes it more ergonomic and easy to insert. Upon holding the connector handle, the user's hand forms a subtle angle with his or her forearm, thus ensuring that there is not much discomfort around the user's wrist. The female connector was designed with a certain tolerance that allowed for an easy, quick insertion of the male connector while still somewhat constraining it mechanically. Below is an image depicting the fabrication process of the male connector handle.

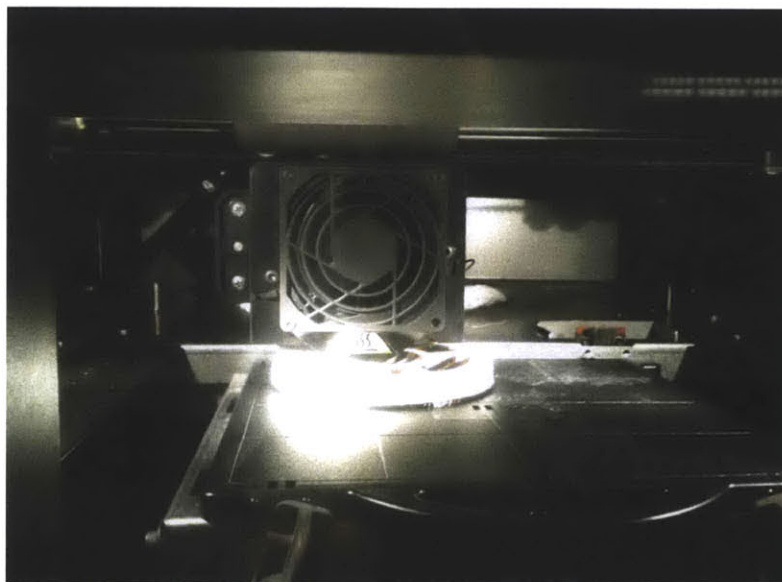

Figure 16: 3D-printing fabrication process for the male connector handle

4.7 Finalized male and female connector

Below is the final assembly for the male (top) and female (bottom) connectors. The external casing was made transparent in order to show all the internal features and components.

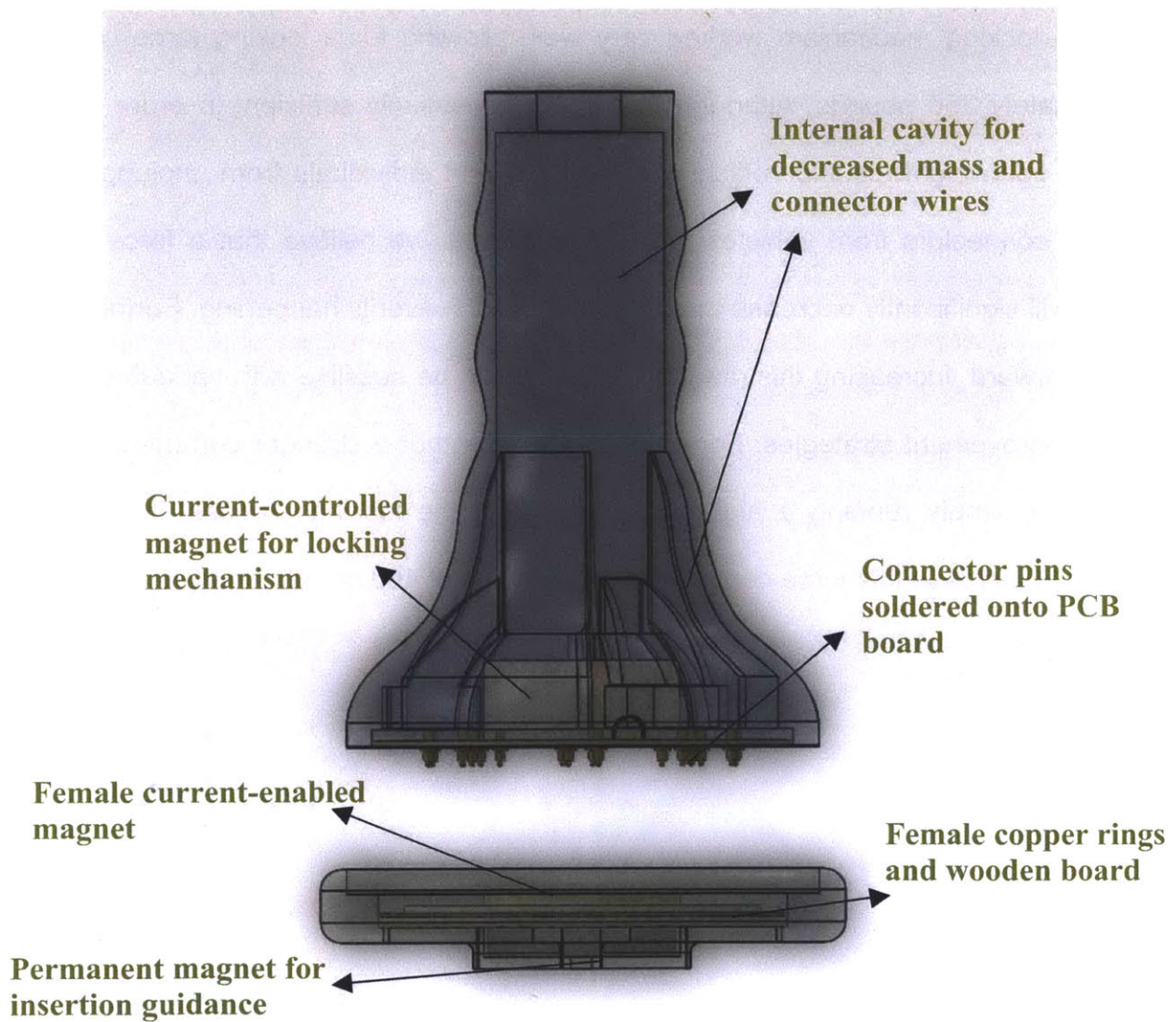

Figure 17: Schematic view of male (top) and female (bottom) charging connectors

5. Testing and future work

Upon fabrication and assembly of smartCharge, we were able to perform various tests. Most of the obtained user feedback was obtained during the MIT Media Lab Sponsor Week in April, when hundreds of highly technology-aware individuals visited provided their opinions on various innovative projects being conducted at the Media Lab. The locking mechanism worked very well, allowing for a locking force of up to approximately 250 pounds. Although this is not necessarily sufficient in order to truly secure a lightweight electric vehicle or simply prevent individuals from unplugging the charging connectors from vehicles in a public setting, we believe that a force of 250 pounds will significantly decrease the likelihood of such events happening. Furthermore, moving forward, increasing this magnetic force would be possible with various different design improvement strategies. For example, using either a stronger current-controlled magnet, or simply running a higher current during the locking process, it would be possible to increase this force considerably to a range of 400 or 500 pounds.



Figure 18: Female connector (left) and inserted male charger (right) with locking mechanism activated

The charging solution platform proposed was engineered with the intent to provide instantaneous, easy-to-detect visual signals about the overall state-of-charge of the vehicles available at a given station. For this reason, smartCharge has a side panel that informs user the level of charge the plugged vehicle has in a more granular method, while a large capsule at the top of the compact charging post changes color to indicate an approximate charging range. This large capsule is visible from a longer distance, so that users who might be potentially waiting for a vehicle to gather enough charge would not need to constantly approach the vehicle in order to find out the most recent state-of-charge. Furthermore, the charging stations also light up with a discrete blue color when no car is parked and plugged at that given location. This would be helpful for individuals trying to identify an available parking spot with the required charging infrastructure.

Unplugged



Low charge



Medium charge



High charge



Figure 19: State-of-charge lighting pattern for smartCharge

As previously mentioned, the stainless-steel retractable arm of smartCharge was designed to provide maximum versatility to charge various vehicles, implying that the

distance between the post and the female connector might vary significantly. Our arm design not only accounted for the required wiring that needed to be supplied to the male connector, but also ensured that this mechanism would not damage these wires internally. For this reason, it was crucial to select a material that was somewhat flexible and had enough clearance so that the extending feature could be utilized without any constraint imposed by the charging mechanism. Below is an image indicating part of the pulley system responsible for providing this important retractable behavior for the connector arm.



Figure 20: Internal electrical system and pulley for retractable arm

Unfortunately, the pulley system turned out not to work as well as it was expected. Although the flexibility and strength of the stainless steel arm allowed for an improved functionality in comparison to existing charging infrastructure technologies, the pulley system failed to provide the additional arm length that we originally desired. The vertical spring-loaded pulley system was not optimal, and a number of pitfalls took place once the station was fully assembled. One of the problems was that the internal wiring that went through the stainless steel tube to the male charging connector did not have clearance for feeding into and out of the tube as the arm was extended. This often caused the wires to prevent the arm from being fully extended. Moving forward, it will be essential to redesign this retractable mechanism. Most likely, the best solution would be to use existing pulley that operate on the horizontal plane (rather than vertical) together with springs that behave slightly more reliably and do not require as much load to be extended.

Finally, one of the most helpful feedback comments related to the charging connector design was that once the locking mechanism was deactivated upon the user tapping his or her card onto the station electronic reader, the handle simply disengaged from the female connector and would swing downwards either hitting the vehicle or the charging post. Since the user might not always have both hands free, it is likely that at times he or she would only tap the electronic ID card without previously holding the male connector in place. Therefore, the handle would often get damaged as people deactivate the locking mechanism and the male connector swings down and hits another object. In order to solve this, future solutions are likely to include one of the two following approaches. First, we could eliminate this problem by using a stronger

permanent magnet, which originally only provided guidance to the user during the insertion process, in order to secure the male and female connectors even if no current is being supplied to the system. This force would not have to be as strong as the actual locking mechanism of 250 pounds of force, since the magnet would only have to overcome the actual male handle weight. Another option would be to design the female connector with an external extrusion that is a bit longer than the current design. This would be a mechanical way to constrain the male connector in place when the locking mechanism is electronically disabled. In the future, both options will be considered and compared in order to arrive at the best possible solution.

6. Implementation considerations for smartCharge

6.1 Station Placement

The defining design features of a MoD system were highlighted in a case-study conducted in Taipei City, Taiwan. This study evaluated the adoption and popular response to the implementation of a public-shared transportation system using the MIT City Car. Taipei is a highly dense city with heavy congestion levels, where the use of compact vehicles in one-way mobility would provide great value to the local community. The social study concluded that the city would have to include a modular charging infrastructure that could be flexible to ongoing adjustment, such as station relocation. Additionally, the MoD system would need to take into account standardized user scenarios, with a flat learning curve for users, thus allowing individuals to follow general guidelines in order to interact with the system without needing personalized guidance. An initial small-scale deployment will be critical to allow the city to slowly increase the number of stations in areas with higher-than-expected demand, without requiring high levels of modularity in the charging infrastructure installation process.

According to the study on Zipcar, mentioned in the Background section, a key factor in the consumer uptake was the density of Zipcar stations, which are available every few blocks in Boston, Cambridge and Somerville. As a result, it is very convenient for customers to find a station to pick-up and drop-off cars for round trips. The demand for convenient one-way rental vehicles, however, is still unmet. For the City Car, the initial challenge will be the capital constraints and uncertainties in the number of stations, which will make their strategic placement critical. In order to maximize the benefits inherited from a publicly shared personal mobility system utilizing

the City Car, it is advisable to target specific ecosystems with high traffic and frequent one-way travelers such as major transportation hubs and hotels. In this section, the city of Boston is used as an example of how city governments and policymakers can determine the most strategic locations for implementing smartCharge in conjunction with publicly shared electric vehicles.

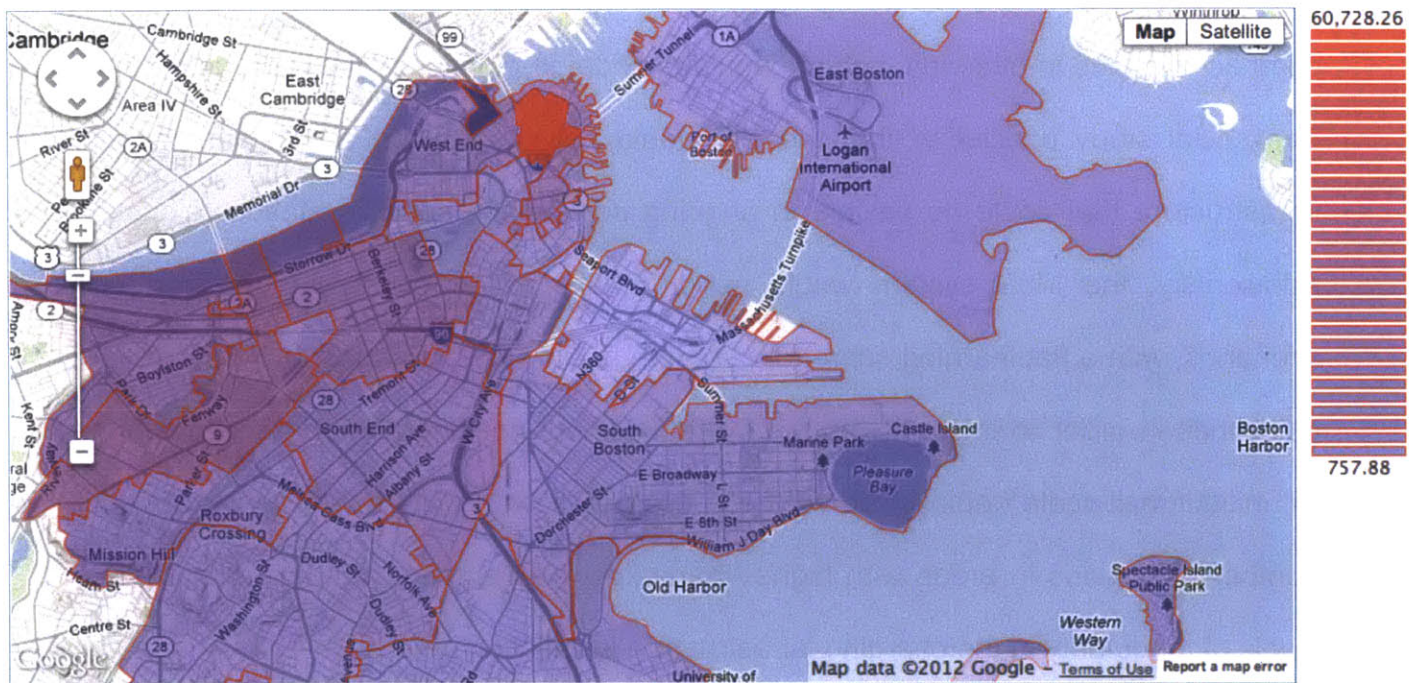

Figure 21: Population density map of Boston

6.1.1 Airport

Logan Airport has many passengers frequently arriving and departing. Most of these passengers need convenient one-way transportation to or from the airport. Currently, that need is mostly met by cabs or mass public transportation. Each of these methods has drawbacks: taxis are expensive; public transportation can be slow, inconvenient or unreliable. MoD vehicles offer an improved alternative that is both

affordable and convenient, especially if other MoD stations are built to enhance one-way mobility in highly-populated areas. Because of its small size, a MoD system using City Cars is most suitable for people on business trips, visiting a university, or traveling alone.

6.1.2 Hotels and Densely Populated Neighborhoods

Coupled with MoD stations at Logan Airport and transportation hubs, placing stations near hotels and dense residential areas will create convenient MoD infrastructure through major high-traffic, high-demand routes. MoD stations will also create added values for hotels, making them more popular accommodation choices.

6.1.3 Boston Financial Center and MBTA train stations

The heavily used MBTA system is the main form of public transportation in Boston. Although MBTA train stations span the area of Boston and several nearby cities -- including Cambridge, Somerville, Brookline, Newton, Malden, Medford and Ashmont. Unfortunately, the system often falls of short; when it comes to getting to places outside of these areas, there is usually no direct route between two locations. Since there is considerable demand for reliable and affordable transportation from these stations to places outside of these areas, T-stops are especially good locations for MoD stations. Specifically, a MoD station should be constructed near high-traffic T-stops such as South Station -- where several MBTA subway lines and buses intersect. MoD stations should also be built at the ends of each line, such as Alewife or Braintree. End-point MoD stations are especially useful for daily commuters, who travel to their

workplace from the train station that has a sparingly scheduled bus or commuter rail train. MoD vehicles can provide flexibility for their commute schedules, or act as an effective back-up option if they miss a bus or train.

6.1.4 Schools and University Campuses

University campuses are usually among the more densely populated areas of Boston, and their traffic volumes are also among the highest. MoD stations near universities interact effectively with those near Logan Airport and other transportation hubs, as universities observe many visitors such as tourists, professors, conference attendees and guest lecturers every day. Most university do not own a car, but travel frequently to and from restaurants and nightlife in the area, their home, or vacation spots. Several locations present themselves as attractive for a MoD station because of their proximity to both university campuses and popular T-stops such as: Harvard Square, Kendall Square, near 77 Mass Ave, Boston University.

6.1.5 Popular Athletic Facilities

Boston is the home of the Red Sox, Bruins, and Celtics, and, because of these teams' national popularity, their games typically draw many spectators from outside of Boston. In addition to being used for athletic events, TD Garden, where the Bruins and Celtics play, is commonly used as a concert and event venue. North Station, a major rail hub for the city of Boston, is attached to TD Garden. Therefore, a MoD station should be placed near TD Garden. A station should also be placed at Fenway Park, where the Red Sox play, which is also a popular tourist destination in the baseball offseason.

Along with the aforementioned MoD stations, these stations form a cost effective ecosystem suitable for the early stages of implementation.

6.2 Electricity source and off-peak charging

Although it is commonly argued that electric vehicles would lead to reduced carbon dioxide emissions, the effectiveness of deploying the City Car as a major transportation option in a dense urban environment would be highly dependent on the sources of electricity for the location where charging takes place.¹³ For this reason, it is critical to consider the electricity source breakdown for any city being considered for the adoption of smartCharge and various publicly shared electric vehicles.

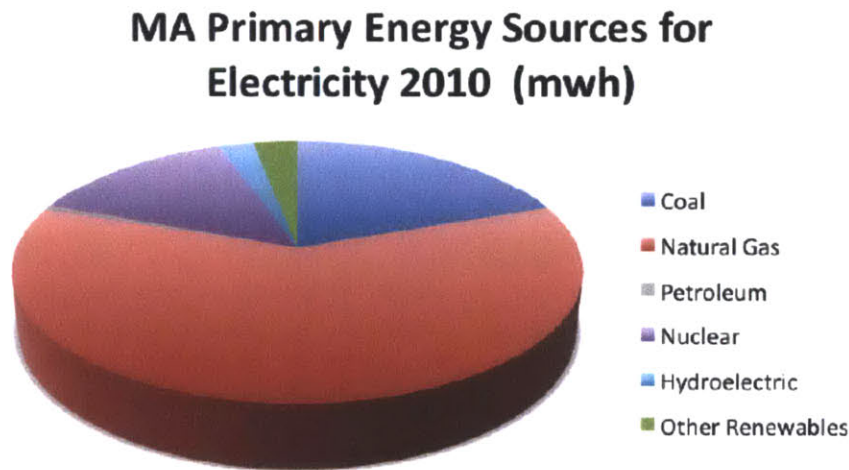

Figure 22: Sources of electricity in Massachusetts

In the case of Massachusetts, as described by the US Energy Information Administration, it is notable that approximately 60% of the total electricity comes from natural gas, a source that is not only cheaper but also cleaner than gasoline. In addition, other critical sources include nuclear power plants and renewables, both of which have

a considerably lower marginal cost, thus making the implementation of electric vehicles in the city of Boston highly appealing.¹⁴

As explained in section 3.3, the defining feature that would allow for mass-scale adoption of publicly shared electric vehicles is the ability to use smartCharge as a platform to direct the bulk charging activity towards off-peak hours. This can be done by ensuring that the stations are programmed to charge the vehicles late at night and prevent charging from taking place during hours of maximum demand for electricity. Based on a 2012 report from the Federal Energy Regulatory Commission, the prices and demand for electricity in Boston reach the lowest value during approximately 10PM to 5AM.

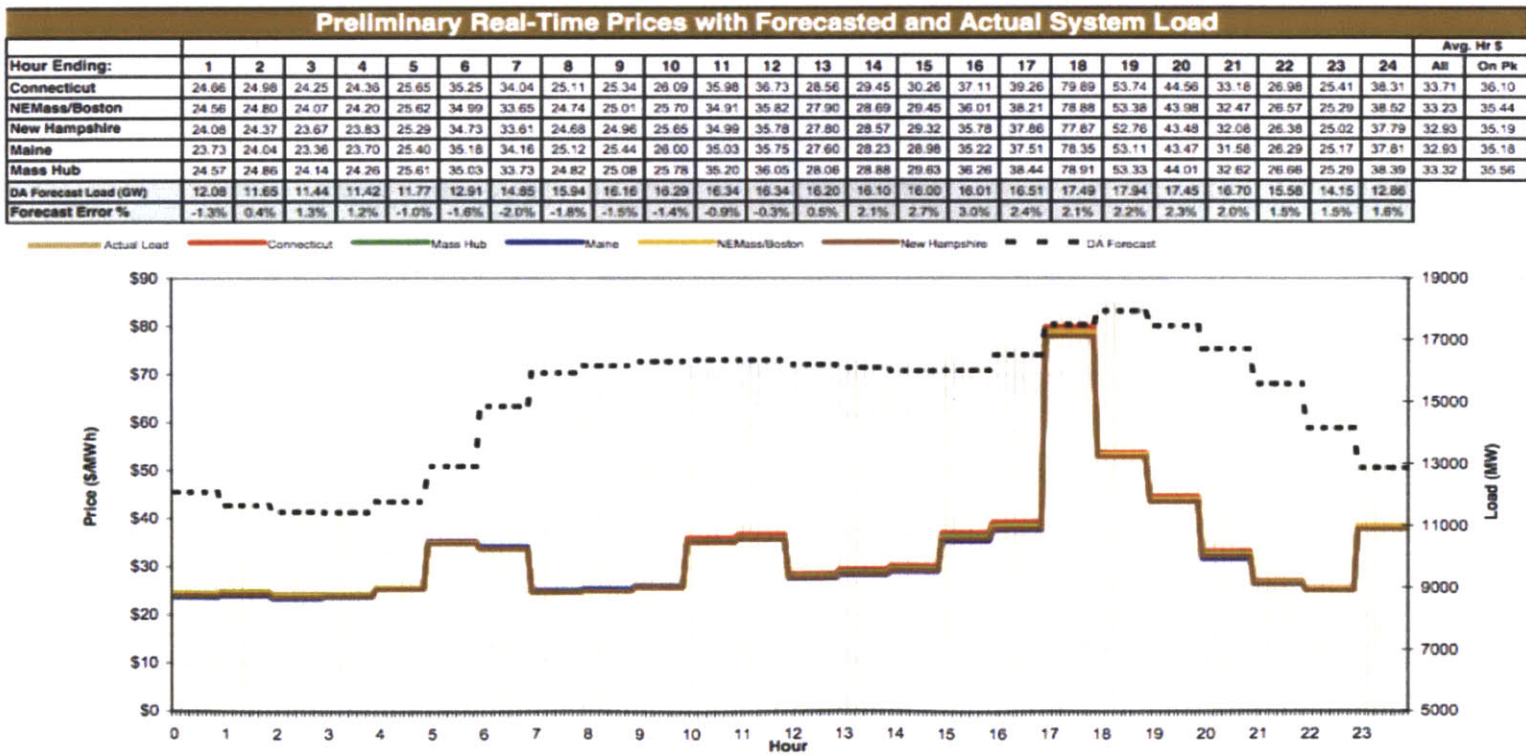

Figure 23: Load per hour in New England

Since the City Car can be driven for 120 miles before requiring charging, it would be possible to considerably “level-off” the daily electricity and load curves for the city, thus ensuring that the adoption of EVs does not lead to an electricity demand that exceeds supply, while decreasing the inefficiency loss due to varying load.¹⁵ However, it is important to note that without the use of a publicly shared charging solution such as smartCharge, the adoption of EVs would be much less appealing and unlikely to allow coordination of the electricity demand for a city.

6.3 Local Culture, Policy Implications and Strategy

For a successful implementation of electric vehicles with smartCharge, it is critical to identify a city where the local culture would be favorable to alternative vehicles, such as the City Car. A study conducted at the MIT Sloan School of Management suggested that an effective diffusion of plug-in hybrid cars and other electric vehicles would require strong positive feedback mechanisms established by word-of-mouth and conditioned by extensive learning initiatives and subsidies to educate the local community and financially facilitate the adoption of alternative transportation.¹⁶ Sticking with our choice of a sample adoption city, it becomes clear that smartCharge would be especially appealing in a place like Boston, where the population is mostly composed of young professionals and college students, while the dominant industries remain as biotechnology, high-tech, and financial services such as venture capital firms.

In order to decrease the burden on the local budget, the city government could apply for financial support. There are federal grants that offer to subsidize “Clean”

Transportation Projects. The adoption of smartCharge could qualify for a few of these, thus making its economics even more appealing. The Clean Cities Initiative offers periodic funding opportunities for alternative transportation deployment projects. A current offer that a project like City Car deployed with smartCharge could apply for up to \$1 million funded by the Department of Energy's (DOE) Office of Energy Efficiency and Renewable Energy (EERE) to encourage Alternative Fuel market implementation programs. The Department anticipates to award 10 to 20 awards for projects to be completed in the next two years. Similarly, the Congestion Mitigation and Air Quality (CMAQ) Improvement Program offers flexible funding for states and local governments to finance transportation projects that will improve air quality by reducing vehicle and congestion emissions.¹⁷

One of the key characteristics of a publicly shared electric vehicle system is the opportunity to have a single state actor coordinating the investment, implementation, administration, and operation of such an innovative scheme. Coordinating all aspects of the implementation of smartCharge, the state encourages the commercial sector to invest in equipment and workforce training. By implementing a system such as the City Car on a limited scale, the state entity overseeing its deployment can effectively manage and optimize each of the features of the system, and ensure that they perform in accordance with a set usage model. A separate division of the transportation administration would manage the deployed electric vehicles and smartCharge infrastructure, while handling responsibilities such as registering users, issuing cards, and tracking revenue and expenses. This division would have a centrally located office to handle these duties, as well as to provide information to users. There could also be a

“Boston City Car” website that would provide safety regulations, usage guidelines, station locations, and availability of vehicles.¹⁸

7. Conclusion

The adoption of electric vehicles would present many environmental and economic benefits, especially when deployed utilizing a Mobility-on-Demand transportation platform. The MIT City Car is a design that successfully incorporates key aspects of EVs and MoD systems, while providing further possibility for decreased congestion and parking space. In order to effectively implement this cleaner mobility solution, however, it is necessary to utilize a publicly shared charging platform that works well for MoD systems.

Unfortunately, existing charging technologies lack the desired features for publicly shared charging infrastructure. Our proposed design, smartCharge enhances the user experience by providing an axially symmetric handle that is easier to insert without requiring rotational alignment. In addition, smartCharge has a uniquely engineered 250 pound-force locking mechanism that incorporates a current-activated magnet in the male connector. The critical components for this innovative connector design include the concentric electric connecting copper rings, the spring-loaded pins, the permanent magnet for facilitating insertion, current-controlled magnet for locking, internal cavities for wiring and decreased mass, and ergonomic external features for ease of use. Performing various tests with smartCharge during the MIT Media Lab Sponsor week in April 2012, it was obtained very strong positive feedback from users and EV-related corporate representatives. Future design work will include a solution to prevent the male connector from simply falling upon deactivating the locking mechanism with the user ID. Currently, as mentioned previously in the paper, there are two potential ways to solve this problem. Another important direction for future work will be to further

improve the stainless steel retractable arm mechanism that utilizes a spring-loaded pulley system. It has been proposed to redesign the pulley system, making it horizontal, rather than vertical, while developing a new solution for handling the necessary extra wiring length that allows the retractable arm to extend from its initial position.

In the last section of the paper, a few critical implementation considerations are mentioned, thus suggesting the benefits provided by smartCharge as well as important policy strategies. For example, to maximize the benefits provided by smartCharge in conjunction with EVs, such as the City Car, it is important to utilize our proposed design to allow for off-peak charging. This will minimize inefficiency losses due to a highly varying load curve, while preventing electricity demand to exceed supply throughout different times of the day. Moving forward, as energy storage technology (i.e. batteries) develops, smartCharge will become even more beneficial. The net demand for electricity will further stabilize because vehicles would be able to buy and sell stored electricity from the grid.

8. References

[1] Boston Hubway Program website. <<http://thehubway.com> > Visited May 9,2012.

[2] ZipCar website. <<http://www.zipcar.com>> Visited May 9, 2012.

[3] Chuang, Chih-Chao, Green Mobility City: With the Arrival of Mobility-on-Demand System With Ultra Small Electric Vehicles (Cambridge, MA: MIT, 2011)

[4] plaNYC Exploring Electric Vehicle Adoption in New York City. 2010. Mayor's Office of Long-Term Planning and Sustainability 2010

[5] US Department of Energy. Energy Efficiency & Renewable Energy. Clean Cities: Financial Opportunities. Website:
<http://www1.eere.energy.gov/cleancities/financial_opps_detail.html?sol_id=522>
Visited May 9 2012

[6] EPRI & NRDC, 2007. Environmental Assessment of Plug-In Hybrid Electric Vehicles. Volume 1: Nationwide Greenhouse Gas Emissions. 1015325. Final Report, July. pp 1–56.

[7] FutureofTech, “Foldable electric car debuts in Europe”, 2012,
<<http://www.futureoftech.msnbc.msn.com/technology/futureoftech/foldable-electriccadebuts-europe-84740>>

[8] Guidance for Implementation of Electric Vehicle Charging, 2010. Transport of London

[9] Papanikolaou, *The Market Economy of Trips*, Massachusetts Institute of Technology, September 2011

[10] Electrification of the Transportation System (MITEI, 2010)

[11] William J. Mitchell, et al., 2010. Reinventing the Automobile: Personal Urban Mobility for the 21st Century. Cambridge, MA: The MIT Press. 120-140.

[12] Gomez San Roman Tomas, Momber Ilan, Rivier Abbad Michel, Sanchez Miralles Alvaro 2011. Regulatory framework and business models for charging plug-in electric vehicles: Infrastructure, agents, and commercial relationships. Energy Policy

[13] Samaras and Meisterling, Meaningful GHG Benefit from PHEVs Requires Low-Carbon Electricity, April 2008

[14] US Energy Information Administration (EIA). State Energy Data System: Massachusetts (1960-2009)

[15] Chuang, Chih-Chao, Green Mobility City: With the Arrival of Mobility-on-Demand System With Ultra Small Electric Vehicles (Cambridge, MA: MIT, 2011)

[16] Struben Jeroen & Sterman John 2006-2007. Transition challenges for alternative fuel vehicle and transportation systems. MIT Sloan School of Management. Revised May 2007

[17] US Department of Transportation website, Visited May 2012

[18] Lutsey, N. and D. Sperling (2012). Regulatory Adaptation: Accommodating Electric Vehicles in a Petroleum World. Energy Policy. 45: 308-316