

Acknowledgement

I would like to thank Waclaw Piotr Zalewski, Professor of Structures, Massachusetts Institute of Technology, for providing me with technical information, guidance, and helpful suggestions.

Table Of Contents

Title page	1
Acknowledgement	3
Table of contents	4
Abstract	8
CHAPTER ONE: Introduction	9
CHAPTER TWO: Cables	15
Theory of Cables	17
Steel Cables	23
CHAPTER THREE: Beams	25
Theory of Beams	27
Wood Beams	37
Solid beams and joists	37
Laminated beams	42
Laminated I beams	44
Plywood/timber beams	45
Built-up solid beams	48
Spaced beams	49
Steel reinforced beams	50
Concrete Beams	51
Rectangular beams	51
Double tees and channels	54
Single tees	56
Keystone and tee joists	60

Ledger beams	62
I and box beams	63
Steel Beams	65
Traditional sections	65
Made-up sections	68
Open web steel joists	70
Lightgage joists	74
CHAPTER FOUR: Trusses And Space Frames	77
Theory of Trusses	79
Wood Trusses	85
Steel Trusses	87
Concrete Trusses	89
Theory of Skeletal Space Frames	91
Steel Skeletal Space Frames	95
Concrete Skeletal Space Frames	96
Application and Theory of Stressed Skin Space Frames	97
CHAPTER FIVE: Arches and Frames	99
Theory of Arches	101
Wood, Concrete, and Steel Arches	105
Lamella Arch	106
Theory of Frames	107
Wood Frames	111
Concrete Frames	113
Steel Frames	115

CHAPTER SIX: Grids, Slabs, and Decking	117
Theory and Application of Grids	119
Theory of Slabs	123
Concrete Slabs	125
One way slabs	125
One way ribbed slabs or pan joist slabs	127
Two way slabs	129
Flat plates	131
Tube slabs	133
Waffle slabs	135
Flat slabs	137
Isostatic slabs	138
Composite slabs	139
Theory and Application of Panels, Planks, and Deckings	143
Wood decking	143
Plywood stressed skin panels	145
Concrete cored slabs	147
Concrete planks and channel slabs	149
Steel decking	151
Steel stressed skin panels	153
CHAPTER SEVEN: Surface Structures	155
Theory and Application of Folded Plates	157
Single Curvature Thin Shells	161
Long barrel shells	164
Short barrel shells	166
North light shells	167

Double Curvature Thin Shells	168
Hyperbolic paraboloid shells	169
Conoids and Doubly Curved Arch Surfaces	173
Geodesic Domes	174
CHAPTER EIGHT: Columns and Walls	175
Theory of Columns	177
Wood Columns	181
Concrete Columns	183
Steel Columns	185
Theory of Walls	187
Wood Walls	189
Concrete Walls	191
Steel Walls	193
CHAPTER NINE: Materials	195
Wood and Its Related Technology	197
Concrete and Its Related Technology	209
Steel and Its Related Technology	217
CHAPTER TEN: References	221

Structural Elements in Architecture

Peter Maratta

submitted to the Department of Architecture on May 11, 1978, in partial fulfillment of the requirements for the degree of Master of Architecture in Advanced Studies.

This thesis is intended to provide undergraduate architectural students a basic outline of the structural elements in architecture. Its purpose is to introduce both the concepts and examples of the elements, to complement a student's other structural resources, and to later serve as a reference.

The organization of the material is threefold. First, the theory section of each classification deals primarily with the structural behavior of the element in order to aid the student in visualizing its nature and function. The application section, on the other hand, provides examples in the three materials, describes any pertinent structural information, and presents production and/or construction aspects to be considered in the selection. The third section concerns the physical properties and technological aspects of each material. This section serves as a reference in order to avoid duplication of information as the different materials are discussed.

Since the architect's language is predominantly graphical in nature, drawings and diagrams are incorporated to further the explanation and understanding of the different elements. Mathematics and formulas are used sparingly due to the non-technical nature of an architectural student's curriculum.

Thesis Supervisor: Waclaw Piotr Zalewski _____

Title: Professor of Structures

ONE

Introduction

Introduction

In order to communicate the subject of structural elements most effectively, the scope of what is to be presented and to whom it is intended for must be clearly stated. These two factors shape and determine the method and means of presentation.

Structure is an essential element of architecture. Consequently, much has been published on the theory of structures and its application. There exist texts, pamphlets, and manufacturer's catalogs on nearly every aspect from methods of analysis to typical construction details. Although this information is relatively available, one finds that each publication deals primarily with only one type of structure or material. Those books which do examine structural concepts fall short in presenting examples of existing structural elements.

During an architect's structural education, the student is confronted with two situations. Knowledge of the basic concepts of structure and the means to calculate them are presented in the classroom. However, there exists no relationship between this and the architectural structures and forms the student applies in the studio. What is often learned in the classroom becomes detached and inapplicable. The student's ignorance of a structural element usually leads to an aversion of it. Eventually, students limit their designs not because they lack knowledge of certain structural concepts, but how these concepts apply to the different elements in their designs.

Therefore, this thesis will be oriented towards the undergraduate

architectural student presently learning about structural systems. It is intended to complement their present resources by providing a concise outline of both the concepts and examples of structural elements currently being employed in the profession. Through this thesis, an attempt will be made to close the gap between the analysis of structures the student learns in the classroom and its final application in the studio.

The organization of the material will be threefold. First, the theory of the structural element will be presented in order to explain the fundamental concepts and to aid the student in visualizing the nature and function of the element irregardless of the type of material. It is hoped that this information will encourage the student to formulate structural ideas and propose new structural systems. The second section deals with the application of the element. Its purpose is to provide examples and to introduce the available structural elements the students have at their disposal. Finally, a section devoted to the physical properties and technological aspects of each material will be included as a reference and to avoid duplication of information as the different materials are discussed.

The theory section will be achieved by classifying the representative elements by their structural behavior. Each classification will be introduced with a brief definition of the element and the general types available. A discussion of the structural behavior will be included to explain any assumptions, force flow, and stability considerations.

The application section, on the other hand, will illustrate examples in the three materials--wood, concrete, and steel. Specific types, physical properties, dimensioning guidelines, construction and production methods, and other critical aspects will be presented for each example.

Since the architect's language is predominantly graphical in nature, drawings and diagrams will be incorporated to further the explanation and understanding of the different elements. Mathematics and formulas will be used sparingly due to the non-technical nature of an architect's curriculum. However, the basic equations and terminologies of statics and strengths of materials will be included.

This thesis is not intended to be a handbook for dimensioning members with tables and recipe formulas. Instead, it will present guidelines to enable the student to have some understanding of the relative scale and mechanisms of each element. Secondly, no structural element will be evaluated as being more superior or inferior to another since the final selection of an appropriate structure depends heavily on the design process. The student must always remember that the load conditions, spanning distances, material selection, construction methods, safety, economy, and physical and psychological aspects of the space determine the type of structure. Finally, this thesis will not examine all the resultant structural systems created by the combination of two or more elements. Representative examples will be mentioned as an aid in comprehending the overall application.

In conclusion, the author does not wish to imply that by reading the following material a student will be an authority on structural elements. Few engineers are proficient enough to analyze all structures. It is hoped that by using this thesis, the student will have a basic understanding of the structural elements, their theory, and application.

TWO

Cables

Theory Of Cables

Definition: Cables are linear elements that are flexible and transfer loads through tension.

I. Types And Classifications

- A. The geometry of a cable is dependent on three factors.
 - 1. The number and location of loads
 - 2. The resulting sag
 - 3. The horizontal distance between supports
- B. The resulting curve or polygonal line for a given load is called the funicular curve or line. There exists five basic profiles or funicular lines for cables.
 - 1. The vertical tie-the cable is attached at the top with the load acting vertically at the bottom
 - 2. Triangular-due to a one point load with supports separated
 - 3. Polygonal line-due to two or more point loads with supports separated
 - 4. Catenary line-due to a uniform load per unit length of cable with supports separated
 - 5. Parabolic line-due to a uniform load per unit length of span with supports separated

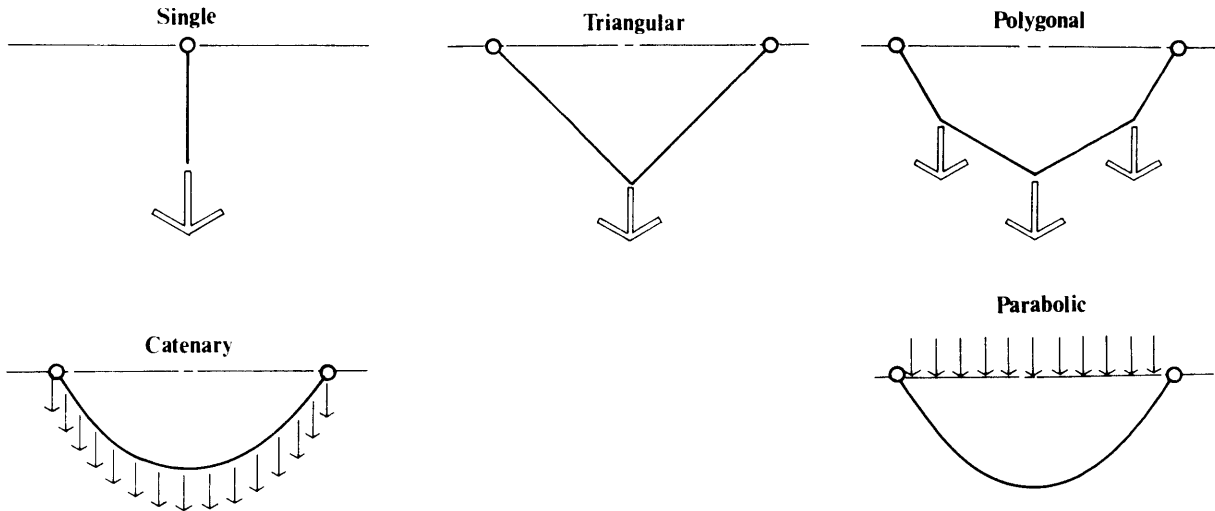

II. Structural Behavior

A. Tensile stresses

1. $f_t = T/A$ where f_t = the actual tensile stress in the cable

T = the tensile force

A = the cross-sectional area of the cable

2. $A_{\min} = T/F_t$ where F_t = the allowable tensile stress

A_{\min} = the minimum area needed to resist the

load

B. Tensile strains

1. $\epsilon_t = f_t / E_t$ where ϵ_t = the strain or elongation per unit length of the cable

E_t = the tensile modulus of elasticity of the material

2. $\Delta L = \epsilon_t L$ where L = the original length of the cable

ΔL = the change in length

3. With an increase in length, there also exists a reduction in width in a direction at right angles to the axis of the cable.

$\Delta d = v\epsilon_t d$ where d = the original lateral dimension of the element (the diameter for circular cross-sections)

Δd = the change in width

v = poisson's ratio

- C. Cables cannot develop bending stresses.
- D. The tensile force at any given section along a cable acts in the direction of the tangent to the cable. The horizontal component of the tangential force is called the thrust.
- E. For triangular profiles:

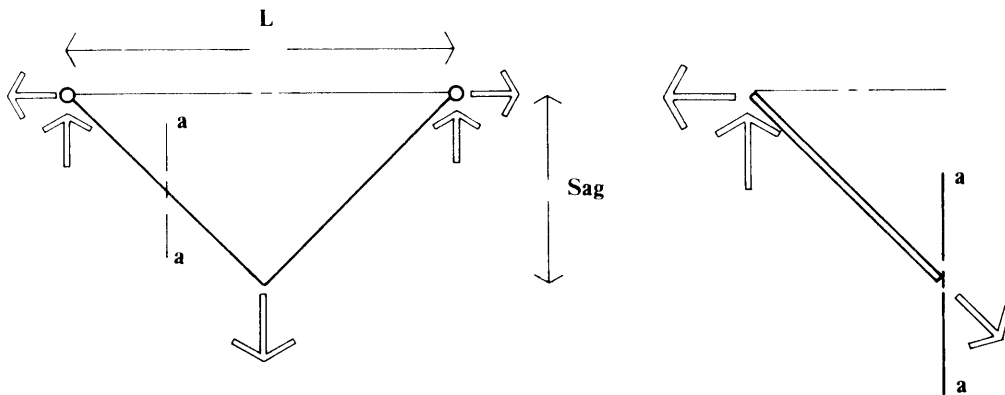

1. The sag of a cable is equal to the bending moment caused by the same loading on a simply supported beam divided by the thrust.
2. The displacements due to n number of loads will be equal to the sum of the individual displacements.
3. The less the sag, the greater the horizontal force at the supports
4. In a 45° triangular cable configuration, the vertical and horizontal force components are equal.

F. For parabolic profiles:

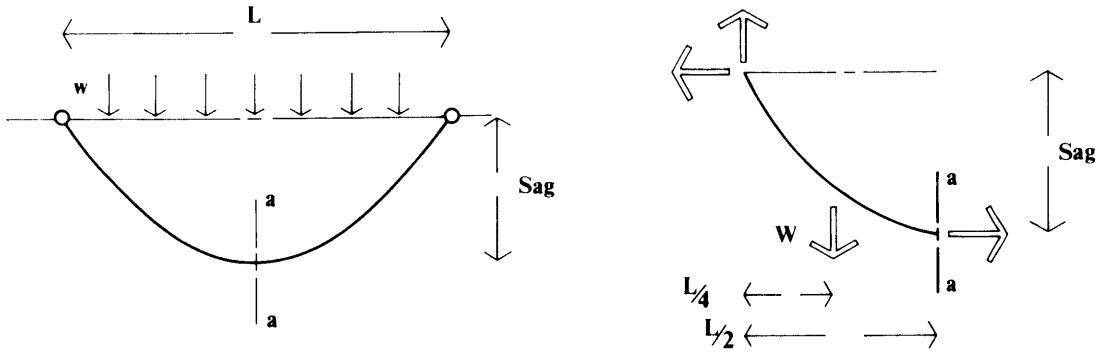

1. Once again, the thrust is equal to the midspan moment of a simply supported beam under the same loads divided by the sag.
2. For a uniformly loaded cable, the thrust is equal in value to the tangential force at the lowest point on the cable.

G. Thrust is inversely proportional to the sag. Note: the vertical components for the same loadings are equal

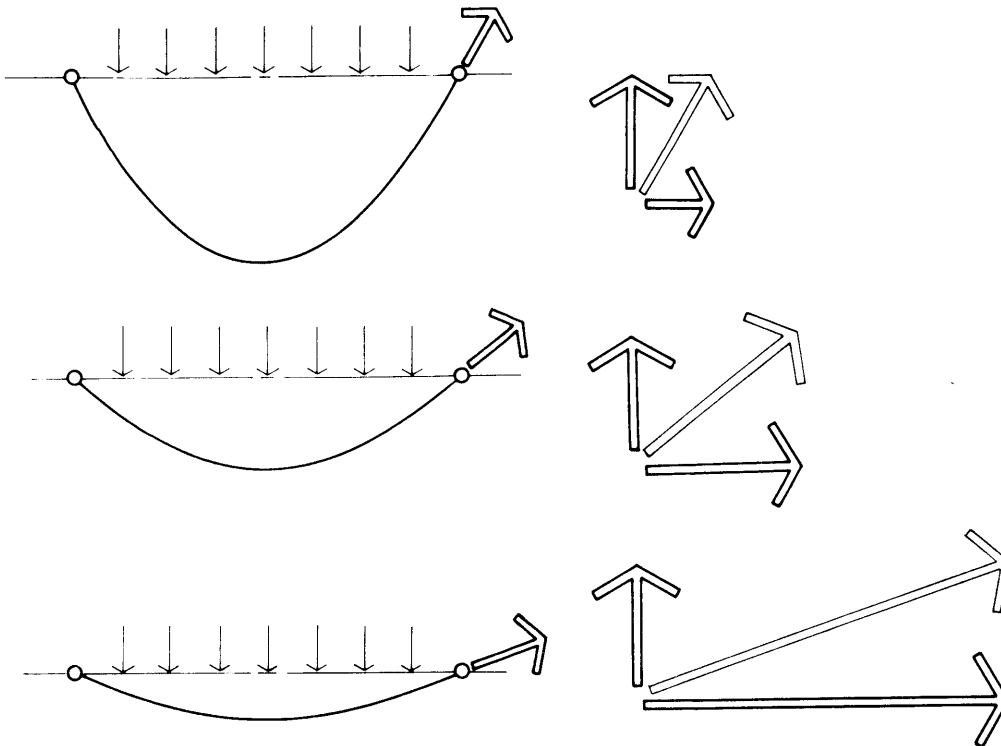

- H. Instability in cable structures in the plane of the curve is chiefly caused by two types of loads.
 - 1. Dynamic loads—the tendency of the structure to vibrate due to loads such as wind
 - 2. Static loads—the shape of the structure will change as the position or magnitude of the load changes
- I. Stability mechanisms in the plane of the curve
 - 1. Countercurvature tension members: This mechanism counteracts dynamic instability by introducing an opposing frequency to the system and therefore dampens destructive vibrations. This mechanism also counteracts static instability by prestressing the system so that unsymmetrical loads have little effect on it. There exists three examples of this technique.
 - a. Compression tied above
 - b. Compression tied partially above
 - c. Tension tied below
 - 2. Increase the dead weight: This dampens vibrations and reduces the percent of unsymmetric loads by adding dead weight.
 - 3. Tying down the cable to the ground: This dampens vibrations by controlling movement normal to the cable curve. Note: This method is not effective in the control of unsymmetric loads.
 - 4. Stiffening through construction as inverted arch or shell: This counteracts the cable's tendency to deflect.

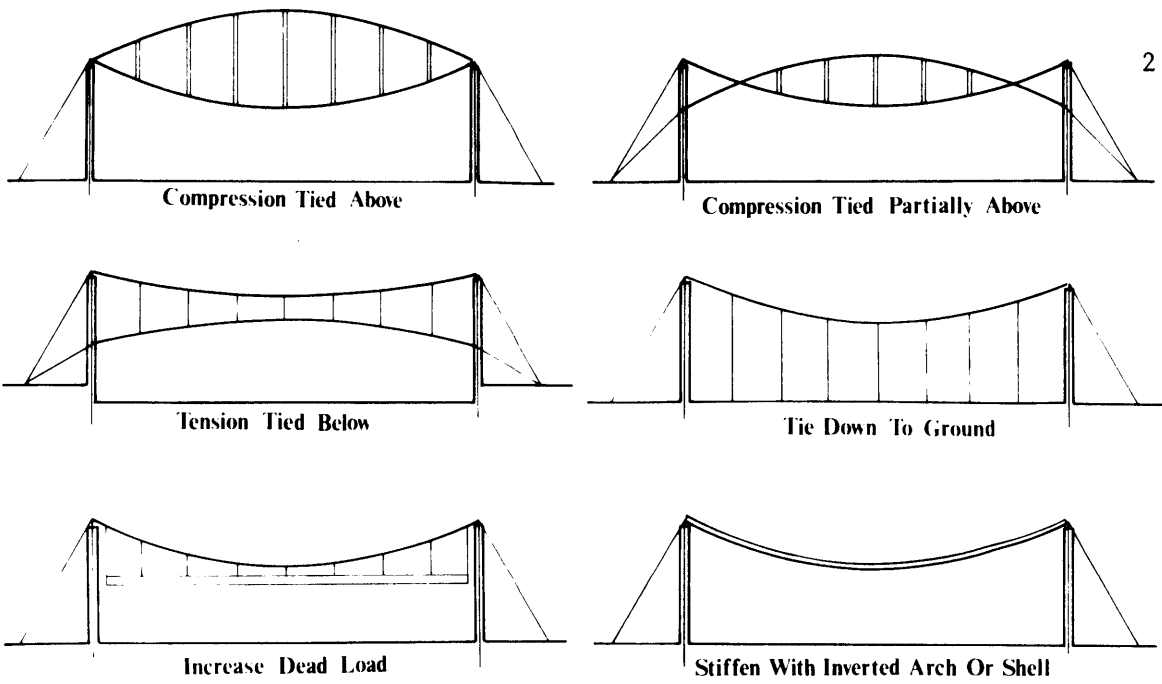

J. Stability perpendicular to the plane must also be achieved.

1. Through transverse beams tied to the ground
2. Through transverse cables with opposite curvature

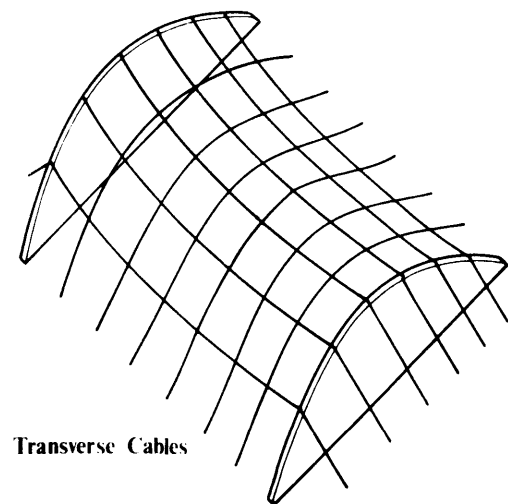
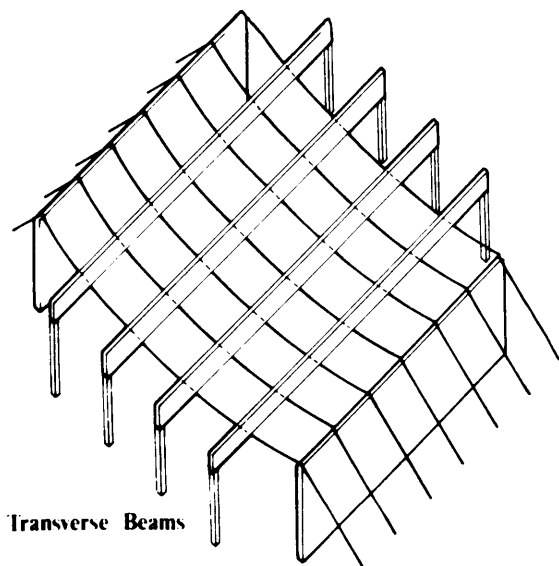

Steel Cables

I. Types And Classifications

A. Varies with cross section

1. Strand--individual wires helically arranged around a central wire

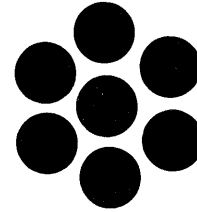

Strand

2. Rope--a number of strands helically arranged around a fiber rope or another strand

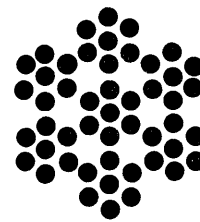

Rope

3. The differences in the two types

- a. Rope is more flexible than strand
- b. Strand has a higher modulus of elasticity than rope.
(24 million psi versus 18 million psi)
- c. Single strands have a higher breaking strength than ropes of equal diameter because they have more metallic area.
- d. Wires in strand are usually larger, more corrosion resistant (when coated) than rope.

II. Structural Behavior

- A. Long uninterrupted spans are possible because of the lightness of weight of the members and the efficiency of simple tension.
- B. Sag/depth--typical working range is 1/16 to 1/8. (a balance between height of supporting structure and cable efficiency)

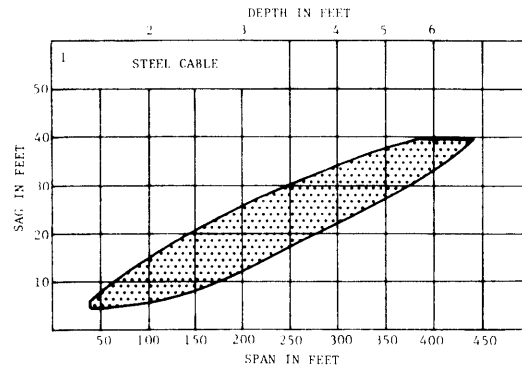

III. Production And Construction

- A. The connections are the most expensive items in cable construction. There exists two major types.
1. Clamp connection--the cable is bent back on itself and fastened with cable clips or U bolts.
 2. Socket connection--the cable is anchored in a socket which is bolted or pinned to the support.
 - a. Zinc poured sockets--the end of a cable is spread out and inserted in a socket which is then filled with molten zinc.
 - b. Swaged socket--the end of a cable is placed into a socket which is then squeezed until it flows plastically around the cable wires.
- B. Cables are factory fabricated for field erection.
- C. Transportation of cables is achieved by winding them around a drum.
- D. Cables are pulled through a wire-drawing die to increase their hardness and strength.
- E. Cable structures are best suitable for long spans and almost exclusively for roof systems.

THREE

Beams

Theory Of Beams

Definition: A beam is a linear structural element which resists transverse loads by developing internal stresses of bending and shear.

I. Types And Classifications

A. Beams are classified by kinds of supports.

1. Simply supported beam

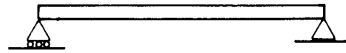

2. Cantilever

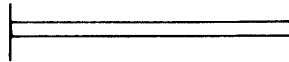

3. Beam with overhang

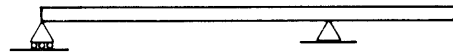

4. Continuous beam



5. Beam fixed at both ends

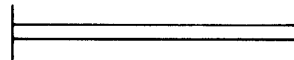

(Note: For these and the various combinations of loadings and supports, see AISC section on beam diagrams and formulas.)

B. Beams are also classified by their cross-sectional shape.

1. Uniform

2. Variable

II. Structural Behavior

A. Bending

1. Bending moments

- a. For a given load on a beam, a bending moment is produced and its magnitude is a function of the location of the load and the type of beam supports.
- b. If the load tends to bend the beam so that the top beam fibers are in compression and the bottom are in tension, the bending moment created is said to be positive. Conversely, if the top fibers are in tension and the bottom are in compression due to the load, then the resulting bending moment is said to be negative.
- c. A bending moment is usually represented directly in terms of the external loads.
- d. By plotting the magnitudes of the bending moment with respect to the beam's longitudinal axis, one obtains a bending moment diagram of the beam.
- e. Examples of bending moment diagrams:

SIMPLY SUPPORTED BEAM WITH UNIFORMLY DISTRIBUTED LOAD

positive bending moment

bending stresses reach their allowable value only at midspan

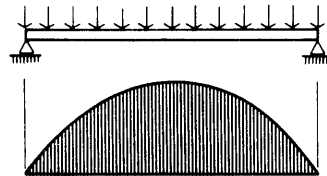

CANTILEVER WITH UNIFORMLY DISTRIBUTED LOAD

negative bending moment

bending stresses reach their allowable value only at the fixed end

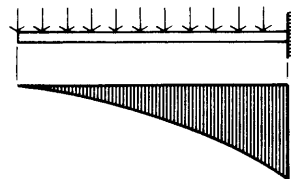

2. Resisting moments

- a. The resisting moment is the internal moment of a beam needed to resist the bending caused by the load and whose magnitude is equal to the corresponding bending moment at a particular section.
- b. The resisting moment is produced by a couple--two equal and opposite forces (the resultant compressive and tensile forces) which act along parallel lines and separated by a distinct distance.

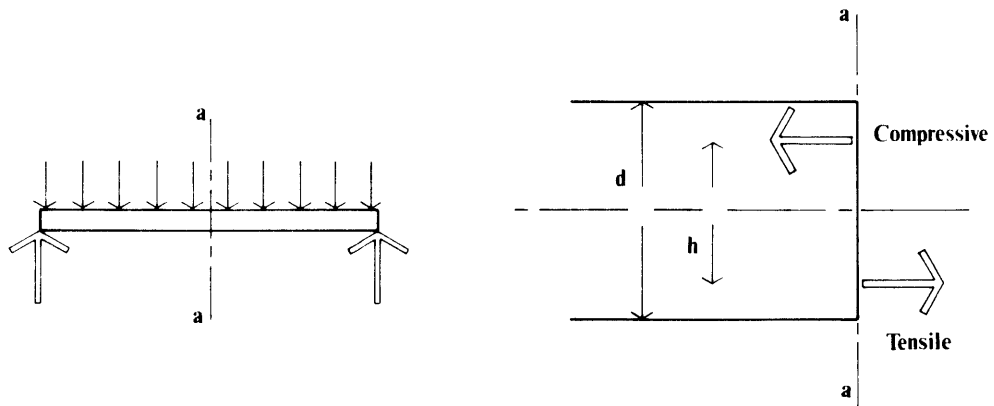

- c. Therefore for equilibrium: $C=T$, $T(h)=M$, and $C(h)=M$

where C = the resultant compressive force
 T = the resultant tensile force
 M = the bending moment
 h = the distance separating forces

- d. The stresses caused by the bending moment are appropriately named bending stresses.
- e. In elastic design, the bending stresses are linear across the depth of the section.
- f. Maximum and minimum stresses occur at the top and bottom beam fibers.

g. At a given section: $f_b = My/I$

where f_b = the bending stress (tension or compression)

M = the bending moment

y = the distance of the beam fiber from the neutral axis

I = the moment of inertia of the cross section

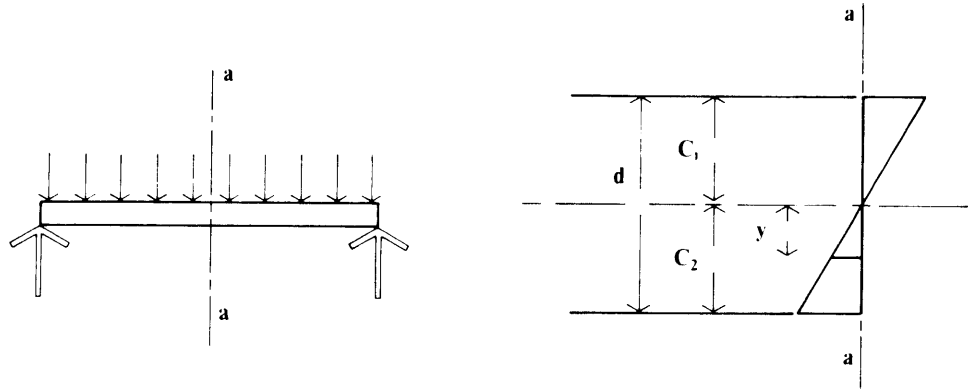

h. In plastic design, the stresses are not linear across the depth of the section. As bending moments increase, more beam fibers are stressed to the yield point of the material. This plastic action spreads from the outer fibers inward.

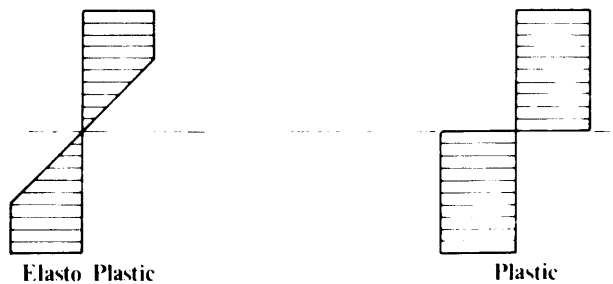

3. Factors influencing resisting bending moments

a. The moment of inertia of the section: $I_{xx} = \alpha Ad^2$

where α = the shape coefficient

A = the area of the cross section

d^2 = the square of the depth of the section

- c. As I increases so does a beam's resistance to bending.
- d. Therefore, a beam is more efficient in resisting bending than another when its cross section has:

A shape in which the material is located as far as possible from the neutral axis (area and depth remain constant)

More area (shape and depth remain constant)

More overall depth (area and shape remain constant)

- e. For example--an I beam is more efficient than a rectangular beam because most of the beam's material is located near the top and bottom of the section.

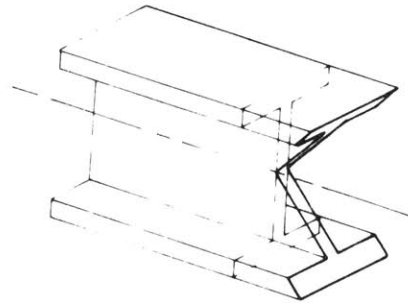

B. Methods of increasing the efficiency of beams in bending (cross sections remaining constant)

- 1. The bending stresses in a simply supported beam which is uniformly loaded reach their allowable value only at the midspan. This may be improved by:

- a. The use of continuous beams--where two types of bending counterbalance each other and thus produce stresses which are more uniform in magnitude. This action can be achieved by one single beam or by a combination of a long and a short beam. The long beam cantilevers over the support and is attached to the shorter beam at points of minimum bending. The splice is approximately $1/4$ to $1/3$ of the span on either side of the internal support.

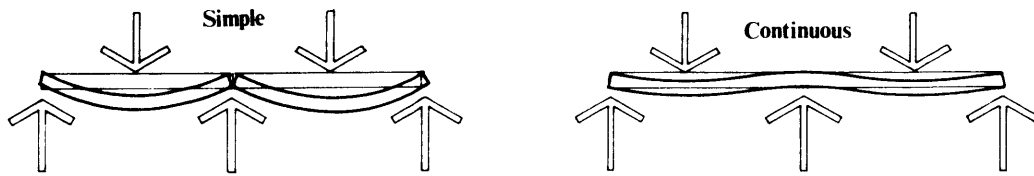

- b. The use of cantilevers--this, like the continuous beam, introduces reverse bending in the beam causing it to reduce the degree of bending at the center of the span. The length of the cantilever should be approximately $1/4$ to $1/3$ of the span.



- c. Fixing the ends of the beam rigidly--this produces similar results however, it also introduces a bending moment into the supports. One should refer to the section on frames for more information.

C. Shear

1. The internal vertical force V acting at right angles to the axis of a beam is called the shear or shearing force.
2. The shear force of a section is the algebraic sum of the vertical components of all the loads (including the reaction) from one end of the beam up to the section in question.

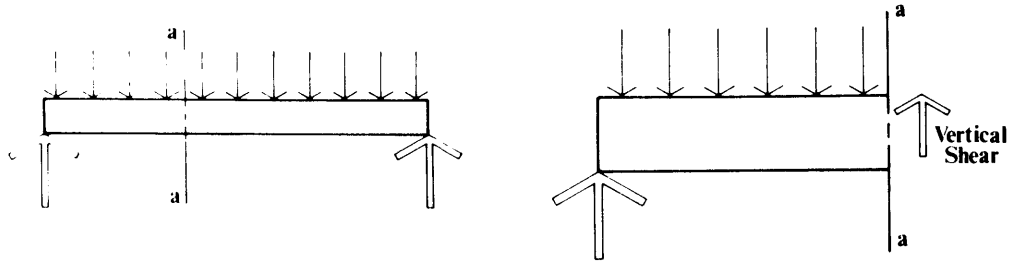

3. By plotting the magnitude of shear with respect to the beam's longitudinal axis, one obtains a shear force of the beam.

4. Examples of shear diagrams:

SIMPLY SUPPORTED BEAM WITH UNIFORMLY DISTRIBUTED LOAD

maximum shear occurs at the supports

zero shear at the midspan

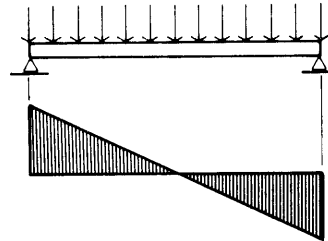

CANTILEVER WITH UNIFORMLY DISTRIBUTED LOAD

maximum shear occurs at the support

zero shear at the free end

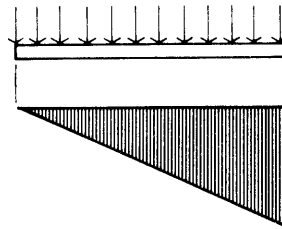

5. The stresses caused by the shear force are called shear stresses. Their magnitudes vary with the distance from the neutral axis and the cross-sectional shape of the beam.
6. For a solid rectangular beam, the shear stresses increase parabolically from zero at the free surface to a maximum at the neutral axis.
7. For the I beam, the shear stresses are approximately constant for the full depth of the section.

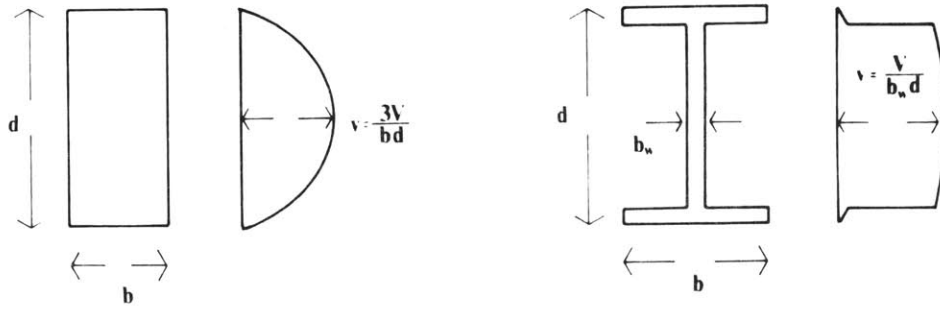

D. The relationship between shear, compression, and tension

1. A beam is transversely loaded causing vertical shear stresses which tend to rotate an element within the beam.
2. To counterbalance these stresses, horizontal shear stresses are created to maintain the element in equilibrium.
3. The resultant of the vertical and horizontal stresses are tensile and compressive stresses acting perpendicular to each other.

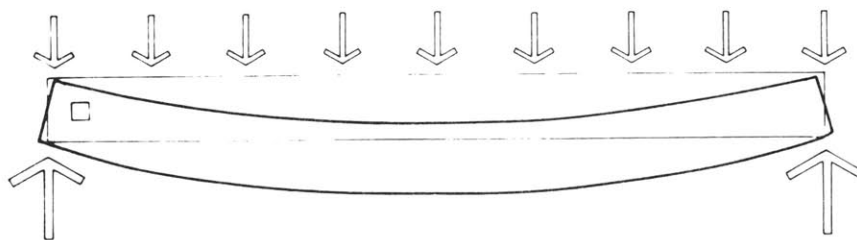
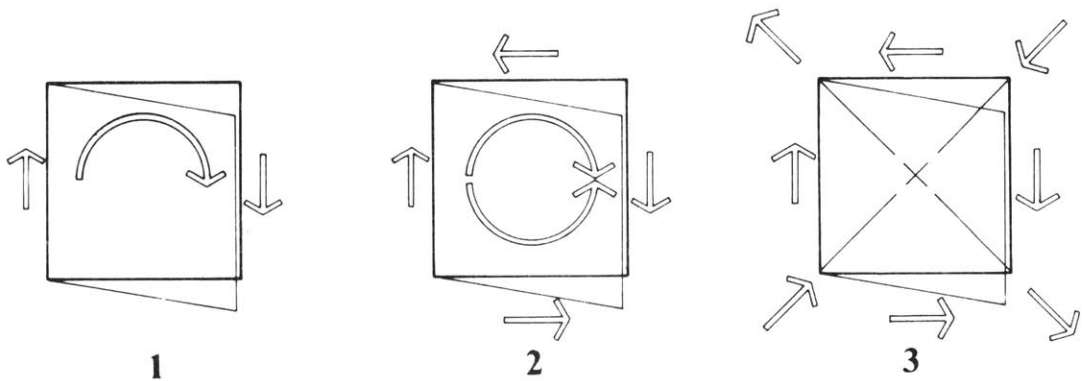

2

E. Deflection

1. The deformation of a beam caused by a specific loading is most easily expressed in terms of the deflection of the beam from its original unloaded position.
2. The deflection is measured from the original neutral surface to the neutral surface of the deformed beam.
3. The configuration assumed by the deformed neutral surface is known as the elastic curve of the beam.
4. The letter 'y' usually denotes the displacement of the beam.



5. Deflection is difficult to calculate mainly because the theory requires knowledge of calculus. However, maximum deflections may be presented as a function of their maximum bending moments.

$$y_{\max} = \mathcal{B} M_{\max} L^2 / EI_{xx} \quad \text{where } \mathcal{B} = \text{coefficient of deflection}$$

E = modulus of elasticity

I_{xx} = moment of inertia

L^2 = square of the beam length

M_{\max} = maximum bending moment

\mathcal{B} varies as the load and support conditions vary however, it can be approximated as equal to: 1/10 for simple beams

1/4 to 1/3 for cantilevers

6. Several texts provide formulas for calculating deflection if one knows the type of beam supports and the loading condition.

7. In many building codes the maximum allowable deflection of a beam is not to exceed span length/360.

F. Torsion

1. Torsion occurs in a beam whenever a load tends to twist it.
2. Torsion develops shear stresses in radial planes perpendicular to the cross section.

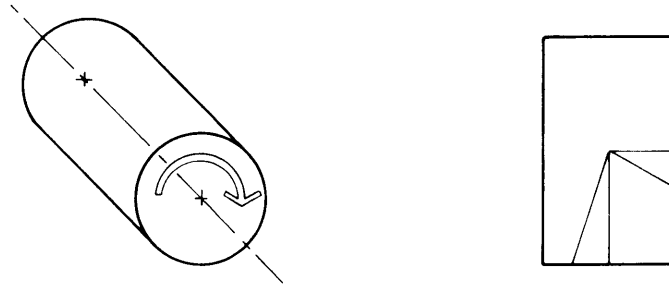

3. The magnitude increases as the distance from the longitudinal axis increases.
4. The most efficient cross sections in resisting torsion are those in which most of the area is located at the perimeters. Therefore, hollow sections are the most efficient.

Wood Beams

Solid Beams And Joists

I. Types And Classifications

A. Solid rectangular wood beams are classified by three means.

1. By dimensions and location of loading

a. Beams and stringers

rectangular cross section

B - 5" and H - 8"

graded according to its strength
when loaded on the narrow face

b. Joists

rectangular cross section

2" - B - 4"

graded according to its strength
when loaded on the narrow face

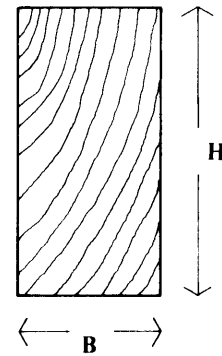

2. By extent of manufacture and strength properties

a. See wood properties section

b. Generally use dressed lumber

c. Generally use select structural, No. 1, No. 2, or No. 3

3. By means of supports

a. Point support--column

b. Linear support--beam or girder

c. Planar support--wall

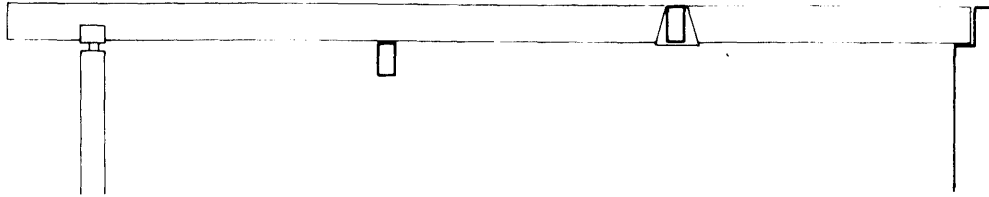

II. Structural Behavior

A. Wood beams behave generally in conformity with classical elastic theory but with some modifications of permissible stresses resulting from the nature of the material. Therefore, structural grades (as previously mentioned) are established.

1. See National Design Specification for Stress-Grade Lumber and its Fastenings for modifications pertaining to:

- a. Relationship between depth and bending stresses
- b. Lateral support of beams
- c. Horizontal shear in notched beams
- d. Provisions governing reductions of loads and combinations of axial and transversal loads

B. Except for very short spans and very large loads--deflection generally controls the depth of the beam.

C. A rule of thumb for joist and beam spans = 24 depth.

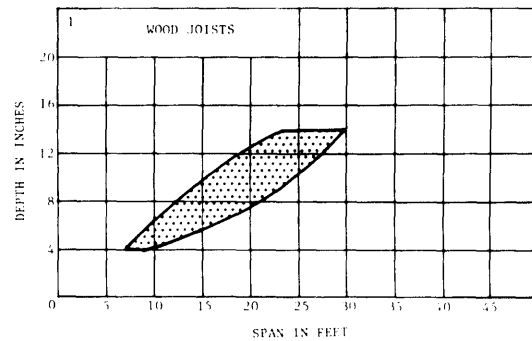
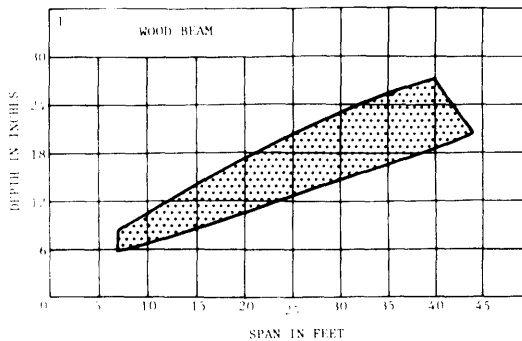

Application: Wood Joist System

1. Joists are supported by either beams or walls.
2. Spacing of joists depends on:
 - a. The design load for the joist depth and span
 - b. The allowable deflection
 - c. Sheathing and ceiling material sizes
3. Joist systems are associated with relatively short spans for sub-flooring and ceiling material. Joists are usually spaced 12", 16", or 24" on center.
4. Fire-resistance rating depends on flooring and ceiling material.
5. Cross bridging is required to prevent the joists from twisting and also improves the diaphragm action of the joist system.
6. Mechanical and electrical lines usually run parallel to the joists.
7. A joist system can accommodate a range of structural bay geometries.

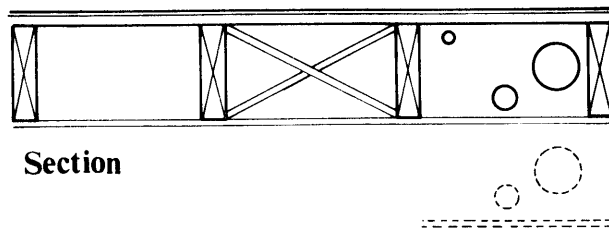
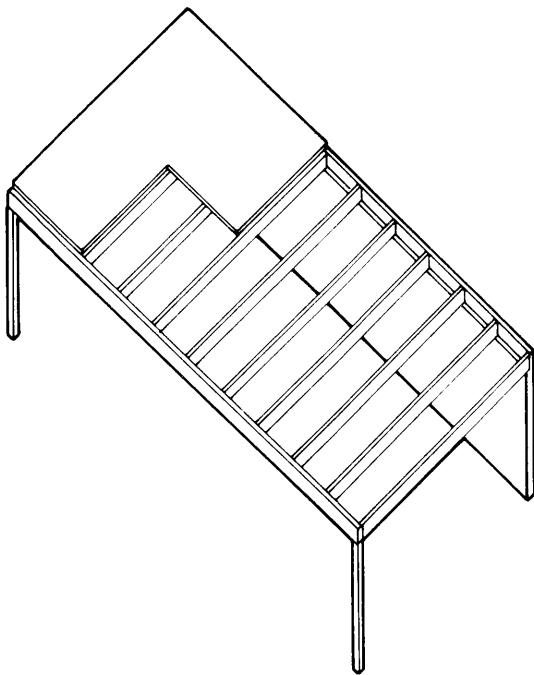

Section

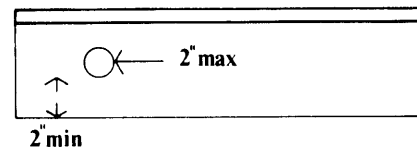

Application: Wood Beam System

1. Beams may be supported by either walls, columns, or girders.
2. Beams are larger and are spaced further apart than those in the wood joist system. Beams are usually spaced 4' on center or greater.
3. A beam system is most effective when supporting moderate, uniformly distributed loads. Concentrated loads may require additional beam framing.
4. The beam system may be left exposed, however one must consider the following factors regarding appearance:
 - a. Quality of wood used
 - b. Quality of joints and workmanship
5. Fire-resistance rating depends on the decking material.
6. The beam system can also accommodate a large range of bay geometries.

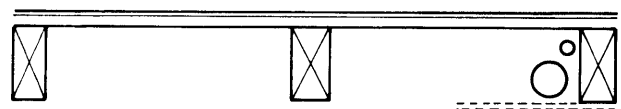
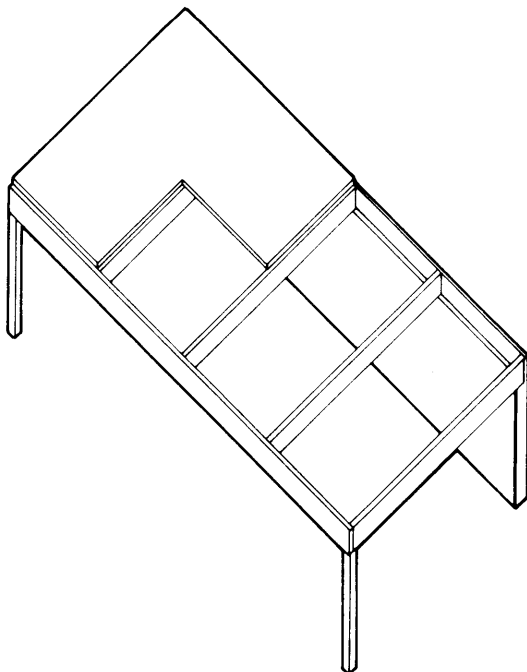

Section

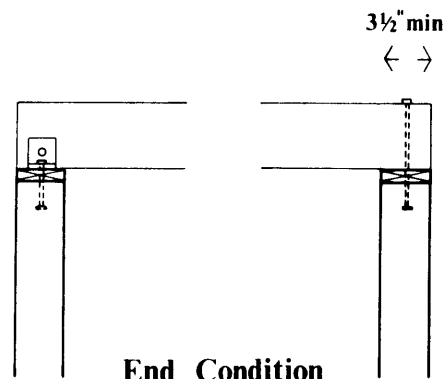

End Condition

Application: In Line Joist System

1. This is an example of how to use a continuous system using long and short members.
2. Longer spans are made possible using standard joist lengths.
3. Splices are alternated on either side of the internal support.
4. Splices are designed for shear resistance.
5. Spacing of joists is similar to that found in the standard wood joist system.
6. See beam theory section for explanation of location of splices.

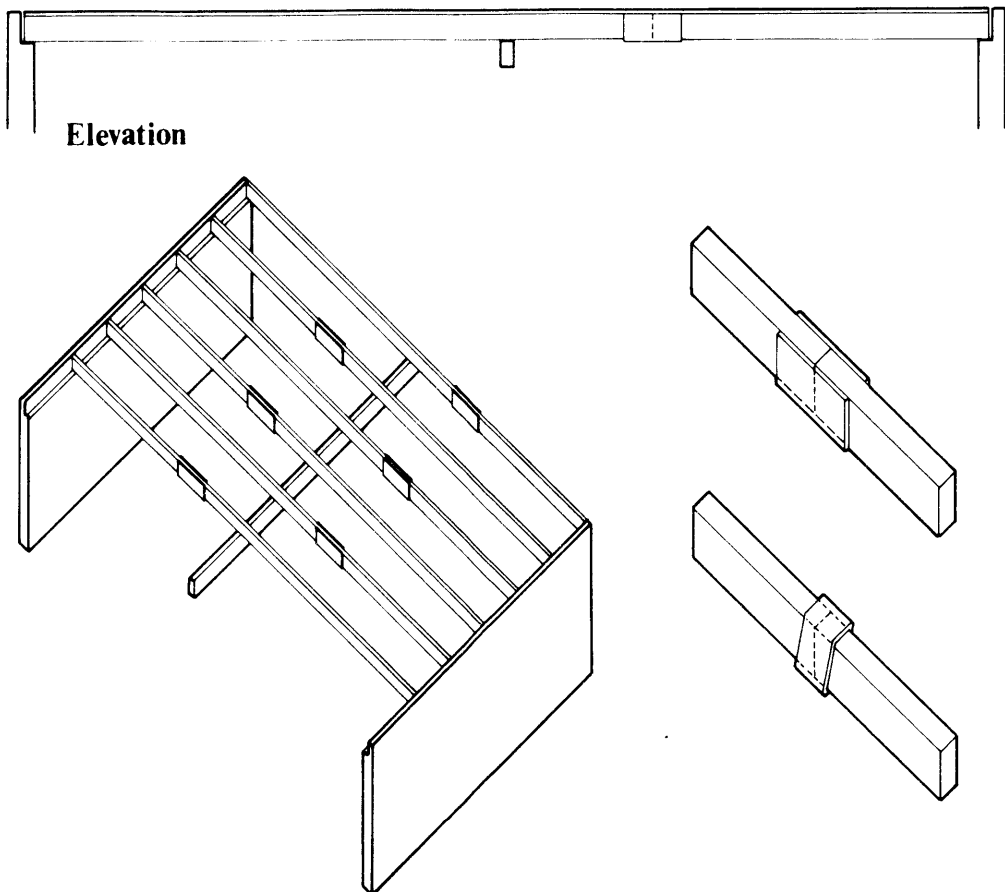

Laminated Beams

I. Types And Classifications

A. Vary with section

1. The number and dimensions of the individual members composing a laminated beam may vary.
2. The laminations shall not exceed 2" in net thickness.

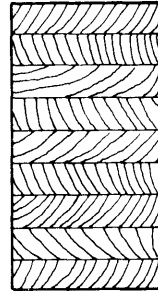

B. Vary with profile

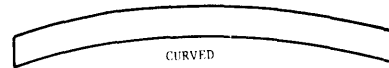
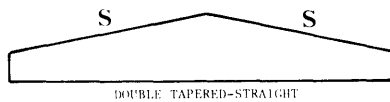
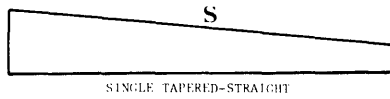

Note:

- a. Tapered refers to a sawn surface--this should be avoided on the tension side of a beam. ('s' denotes a sawn surface.)
- b. Pitched refers to an unsawn surface.

II. Structural Behavior

- A. Laminated beams behave similarly to solid wood beams.
- B. Laminated beams are engineered, stress-rated structural timbers.

- C. For service conditions involving low moisture contents, inspection and seasoning permit higher design stresses than for solid timbers.
- D. Several grades of lumber may be used.
 - 1. The higher grades in areas of highest stress--outer plies
 - 2. The lower grades in areas of lower stress--inner plies

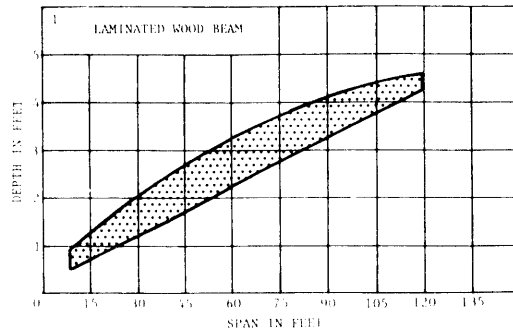

Laminated I Beams

I. Types And Classifications

- A. Vary with the cross section
 - 1. Horizontal laminated
 - 2. Horizontal laminated with applied flange battens
 - 3. Vertically laminated with applied flange battens
 - 4. Vertically laminated with horizontal laminated flanges
- B. Laminated I beams usually have a straight profile.

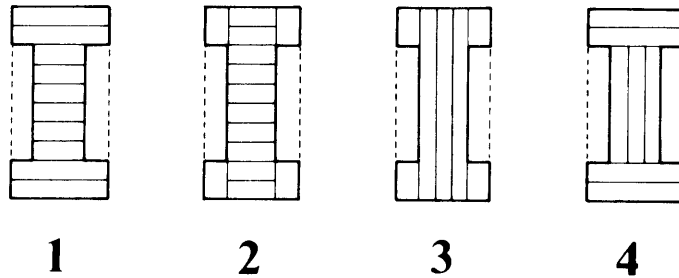

II. Structural Behavior

- A. Laminated I beams are somewhat more efficient than solid rectangular beams, as their material is concentrated in the compression and tension zones of the beam.
- B. Horizontal shear may be the controlling factor in such beams. The flange must be securely fastened so the web and the flange act as one unit.
- C. To prevent buckling, web stiffeners become essential in deep beams with thin webs.

Plywood-Timber Beams

I. Types And Classifications

A. Vary with section

1. Box beams
2. I beams

B. Like laminated beams, their profiles may vary due to the fact that they are composed of parts which can be individually shaped.

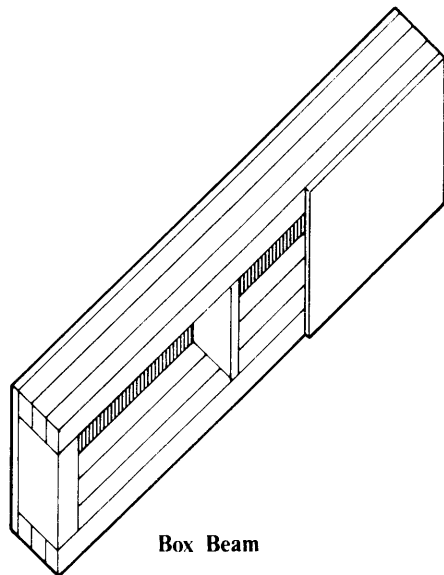
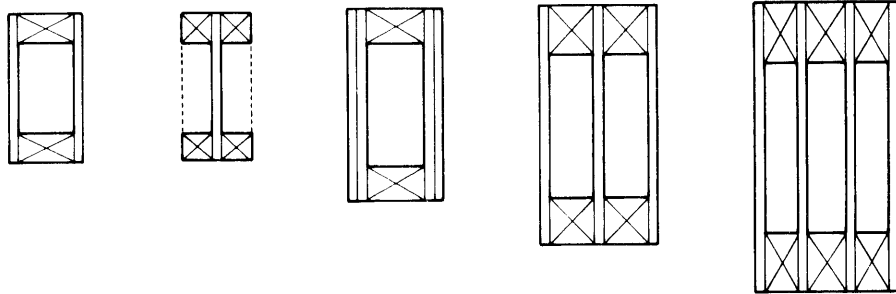

Box Beam

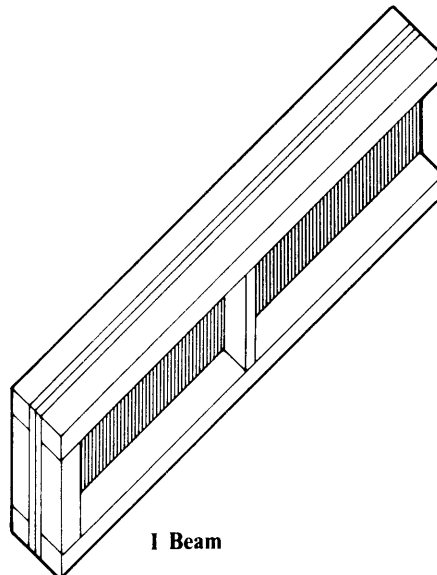

I Beam

II. Structural Behavior

A. Plywood/timber beams consist of an assembly of simple wood elements fastened together in a manner that develops the capacity of its components.

1. Shear resistance is furnished by two or more plywood webs.
 2. Moment capacity is developed by the wood flanges.
 3. Stiffeners are placed at intervals to prevent buckling of the plywood webs.
 4. Both flanges are axially stressed.
- B. The critical structural requirement is usually shear. Two types of shearing stresses exist.
1. Horizontal--can be controlled by providing an adequate web area
 2. Rolling--can be controlled by providing an adequate web to flange area
- C. The loading capacities can be varied by:
1. Varying the thickness of the plywood web
 2. Varying the size of the lumber flanges
 3. Varying the number and location of flanges and web elements
- D. The number and thickness of webs in the box beam may be increased near the supports so as to increase the resistance to shear without affecting the appearance.



- E. Plywood/timber beams are lighter in weight than comparable beams spanning equal distance with equal loading.

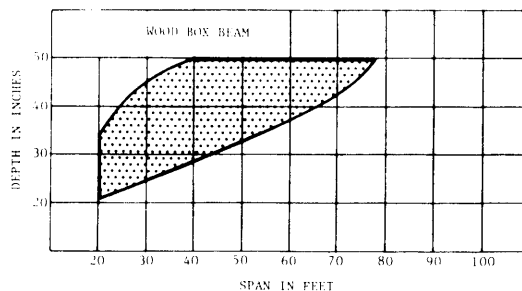

III. Production And Construction

- A. Gluing is considered the most satisfactory method of joining the members, although nailing and bolting, either alone or with gluing, have been used.
- B. For maximum efficiency and reliability, plywood/timber beams should be shop fabricated.
- C. Short vertical stiffeners are inserted at intervals equal to twice the clear distance between flanges and/or at positions of large point loads.
- D. Plywood/timber beams are adaptable to the design of tapered and curved forms.
- E. Plywood/timber beams can also be spliced on the site to achieve longer beams not possible due to limitations of transportation or construction.

Built-Up Solid Beams

I. Types And Classifications

- A. The number and dimensional properties of the component elements may vary.
- B. Built-up solid beams are more dimensionally stable than solid wood beams.
- C. Other categories for solid wood beams apply to built-up beams.

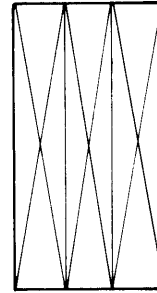

II. Structural Behavior

- A. Primarily the same guide lines for solid rectangular beams are applicable to built-up beams.
- B. It is important that the members remain as one element. One must guard against shear of one member with respect to another.
- C. It is advantageous to join members vertically in order to achieve more efficient strength and stiffness.

III. Production And Construction

- A. Built-up beams consist of members having relatively small dimensions because:
 - 1. To reduce the effects of seasoning
 - 2. To utilize available smaller sizes
 - 3. To reduce effect of knots and other strength reducing features
- B. Joining of members is usually achieved by:
 - 1. Bolts and/or glues
 - 2. Bolts with ring connectors

Spaced Beams

I. Types And Classifications

- A. The dimensional properties of the component elements may vary.
- B. The profile of a spaced beam is usually straight.
- C. These beams are more dimensionally stable than solid wood beams.

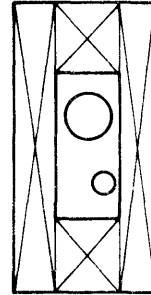

II. Structural Behavior

- A. It is important that the individual members act as one unit. (Spacers should be placed at frequent intervals in order to prevent members from buckling laterally.)
- B. Only the two exterior components are used in transferring the load.
- C. Because of the increased width of the section, spaced beams require less lateral bracing than solid beams carrying equal loads.

III. Production And Construction

- A. Spacers may be either nailed or bolted.
- B. Because of the open section, mechanical or electrical systems can be concealed within the beam.

Steel Reinforced Beams

I. Types And Classifications

- A. Varies with the number and dimensional properties of the component elements. Examples of steel reinforcement include:
1. Solid vertical plates
 2. Angles
 3. Channels

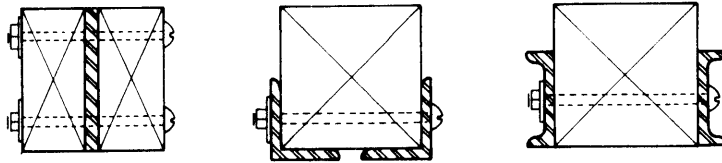

II. Structural Behavior

- A. They are generally considered only for conditions where reinforcement of a wood beam is required to increase its load bearing capacity without a corresponding increase in depth.
- B. Design is based on the assumption that the wood and steel sections will carry loads proportionate to their stiffness, which depends in each case on the moment of inertia of the section relative to the axis of bending and the modulus of elasticity of the material.

III. Production And Construction

- A. The steel is attached to the wood by either screws or bolts.
- B. Good timber to steel connections are particularly important to ensure that there is no buckling of the steel plates or members.
- C. They are considered uneconomical for general construction and only are used when there are restrictions in height.

Concrete Beams

Rectangular Beams

I. Types And Classifications

A. They vary with cross-sectional dimensions and the location and amount of reinforcing steel.

B. Common types of concrete rectangular beams include:

1. Singly reinforced
2. Doubly reinforced

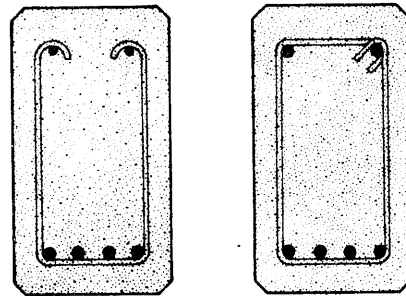

II. Structural Behavior

A. For singly reinforced rectangular concrete beams

1. Concrete resists compression. C = the compressive resultant
2. Steel resists tension. T = the tensile resultant
3. Moment resisted by internal couple. M = bending moment due to load

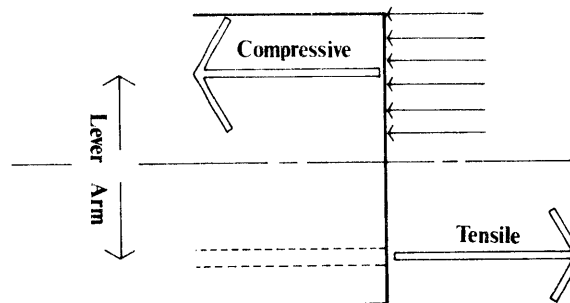

4. For equilibrium, two conditions must exist.

a. $C = T$

b. $M = T(jd)$ or $M = C(jd)$

B. For doubly reinforced rectangular concrete beams

1. If a beam is limited in depth so that the concrete cannot develop the compressive force required to resist the given bending moment, then reinforcing is added in the compression zone.

2. It is also common practice to place reinforcing bars in the compression zone to support stirrup bars which are continuous throughout the beam span.

3. Concrete and the top reinforcing steel resist compression.

4. The bottom reinforcing steel resists tension.

C. The above discussion is directed

to rectangular concrete beams

which are primarily loaded on the narrow face.

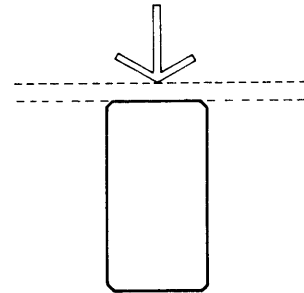

D. For a complete description of the

mechanics of simply reinforced,

pretensioned, and post-tensioned

concrete beams, see the physical and technological section on concrete.

E. To counteract the diagonal tensile stresses associated with shear failure of concrete, web reinforcement is added. This is achieved by two means.

1. Bending a part of the longitudinal steel which is no longer needed to resist flexural tension

2. The use of stirrups

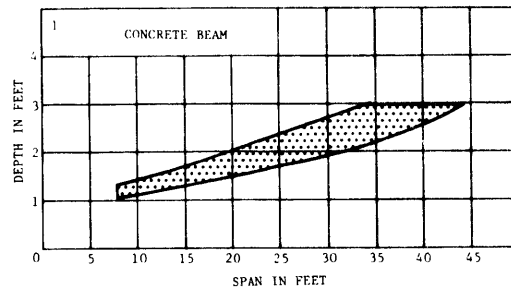
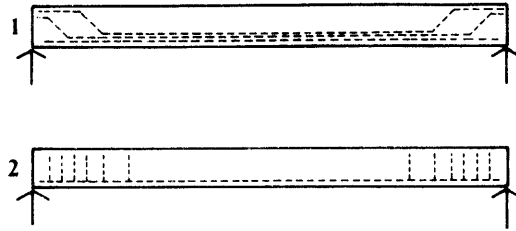
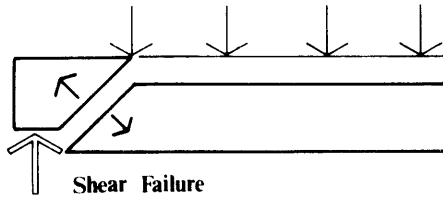

III. Production And Construction

- A. Solid rectangular concrete beams can be produced by two methods.
 1. Cast in place
 2. Precast
- B. The load carrying capacity of both types of beams can be increased by prestressing the element.
 1. By pretensioning
 2. By post-tensioning
- C. The load carrying capacity can also be increased by varying the components.
 1. The quantity of steel reinforcing
 2. The allowable stresses of the component materials

Double Tees And Channels

I. Types And Classifications

A. Varies with manufacturer:

NOMINAL WIDTH	AVAILABLE DEPTHS	AVERAGE WEIGHT PER LINEAR FOOT
4'	10" - 16" *	190 lbs.
5'	18"	280 lbs.
6'	12" - 16" *	320 lbs.
8'	12" - 36" *	380 lbs.
10'	32"	640 lbs.

* available in 2" increments between given ranges

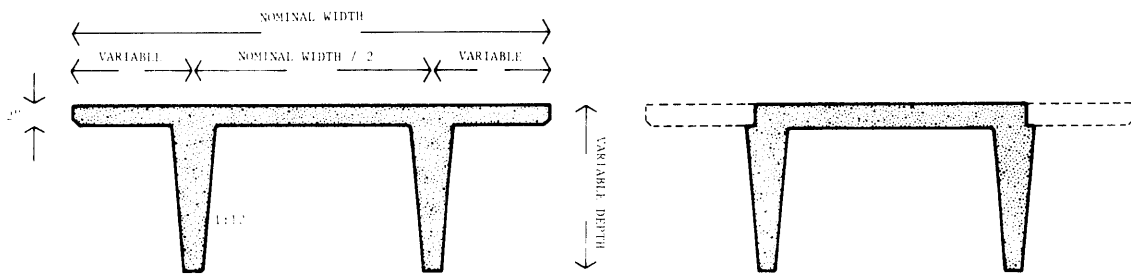

5

II. Structural Behavior

A. After the double tees or channels are set into place, a concrete topping which is typically 2" in thickness is poured. Its purpose is to:

1. Level the cambered top surface
2. Make the double tees or channels behave monolithically

B. The allowable stresses of the concrete and steel and the quantity of reinforcing steel used in the section may be varied to alter the load capacities of the elements.

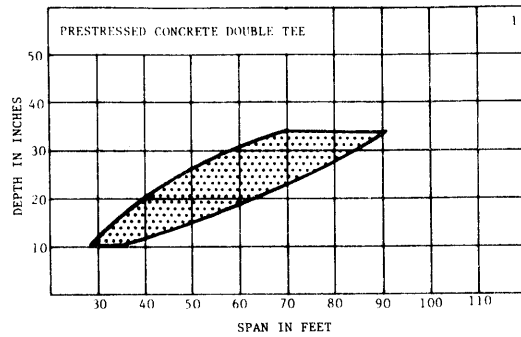

III. Production And Construction

- A. Both double tees and channels are prestressed, precast concrete elements.
- B. Channel sections are usually formed in standard double tee molds.
- C. One should contact the local manufacturers of the elements for exact dimensions and availability of particular sections.
- D. The concrete used in the elements may either be lightweight or normal weight concrete.
- E. Since these elements are usually transported to the site, one must check the transportation size limitations.
- F. If problems occur in transportation, precasting of the elements can be done at the site.
- G. Camber of the double tees and channels depends on:
 1. The structural requirement of the member to control long term deflection.
 2. Plant or site storage procedure--wrong location of supports previous to erection may increase camber.
 3. Length of time the element is erected without applying topping.

Single Tees

I. Types And Classifications

A. Varies with manufacturer:

NOMINAL WIDTH	AVAILABLE DEPTHS FOR LIGHTWEIGHT	AVAILABLE DEPTHS FOR NORMAL WEIGHT	AVERAGE WEIGHT PER LINEAR FOOT *	
			L	N
6'	36" - 60" **	20" - 48" **	430	450
8'	36" - 60" **	20" - 48" **	500	560
10'	36" - 60" **	20" - 48" **	600	690
12'	36" - 60" **	20" - 48" **	710	840

* weight in pounds

** available in 4" increments between given ranges

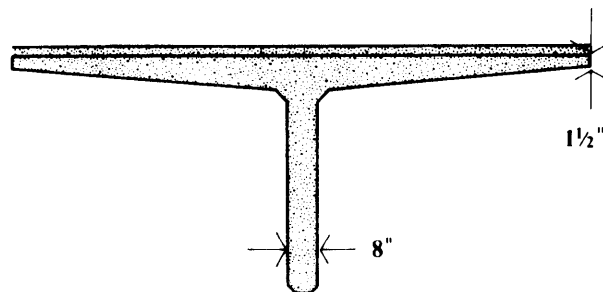

II. Structural Behavior

- A. A typical 3" floor topping is required in order to level the cambered top surfaces and to make the elements behave monolithically.
- B. The allowable stresses of the concrete and steel and the quantity of reinforcing steel used in the section may be varied to alter the load capacities of the element.

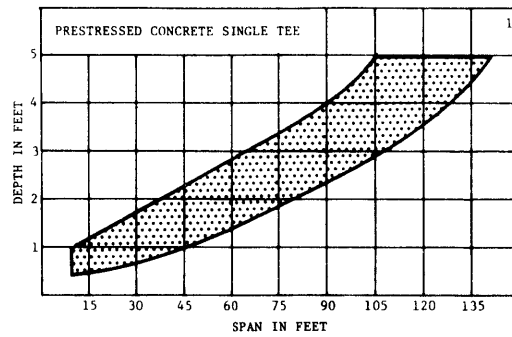

III. Production And Construction

- A. Single tees are prestressed, precast components.
- B. They are usually formed from a flexible mold, so that changes in dimensions can be easily made.
- C. All sections are commonly available in lightweight or normal weight concrete.
- D. One must allow for transportation limitations.
- E. One must also check manufacturer in the local area for availability of a particular section.

Application: Double And Single Tee Systems

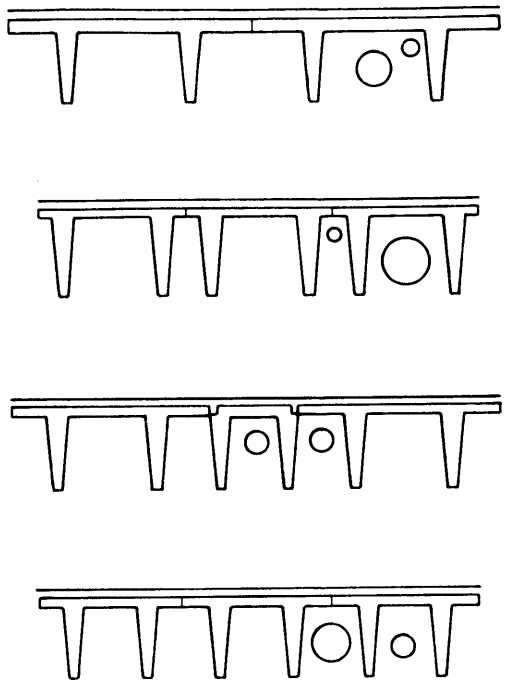
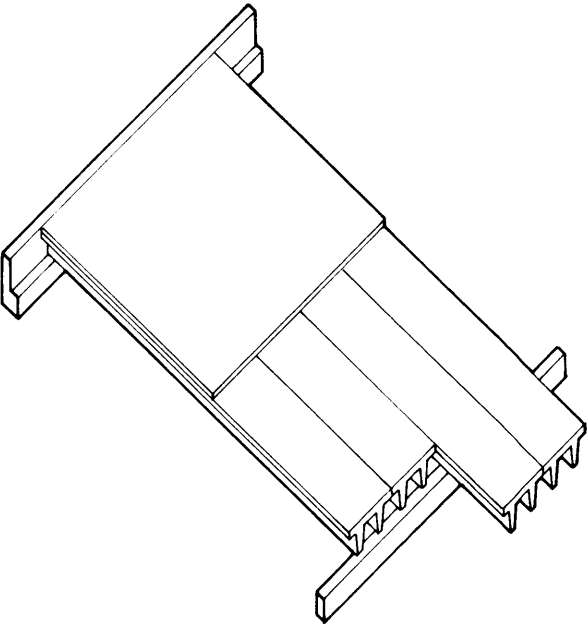

Section

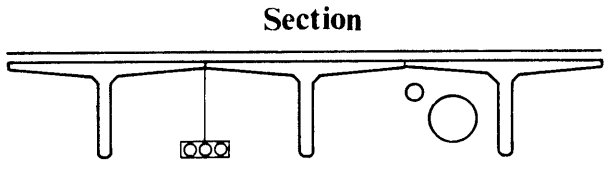
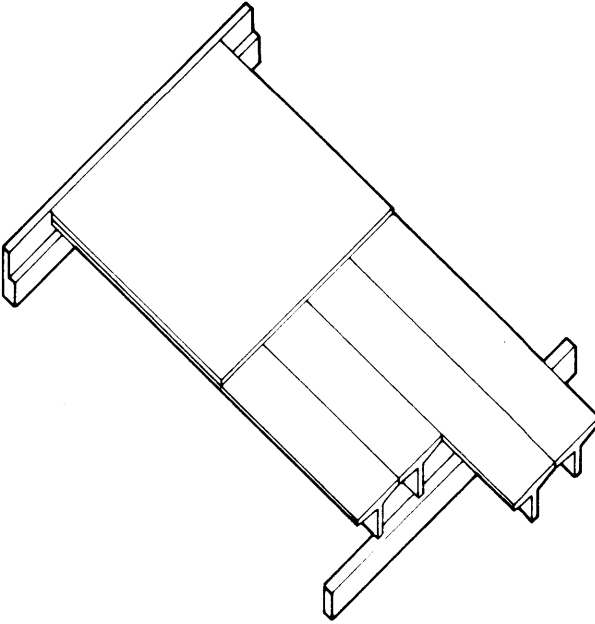

Section

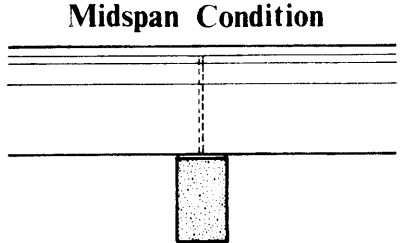

Midspan Condition

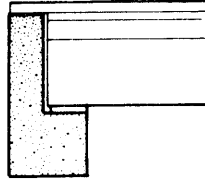

End Condition

Application: Channel Systems

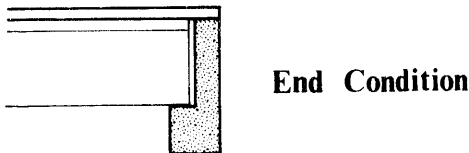
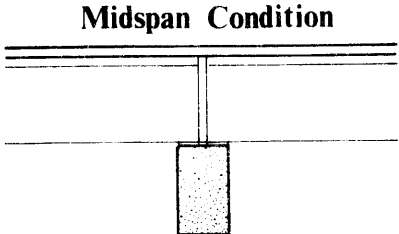
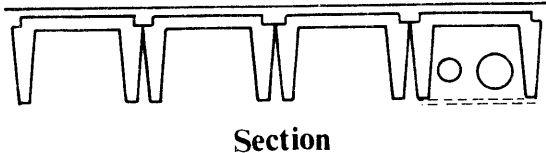
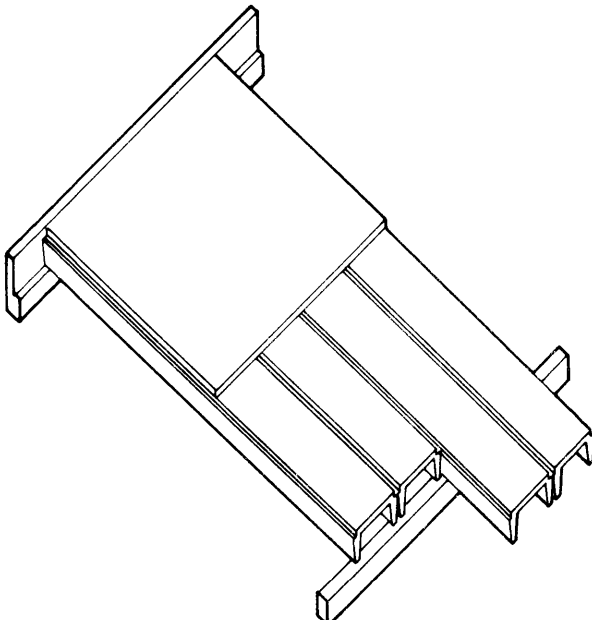
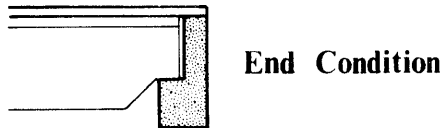
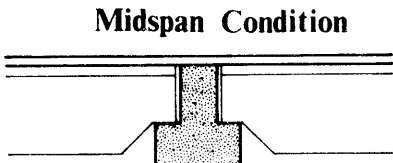
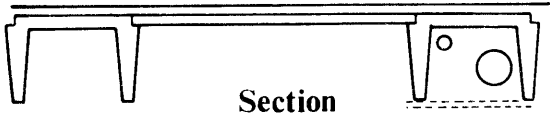
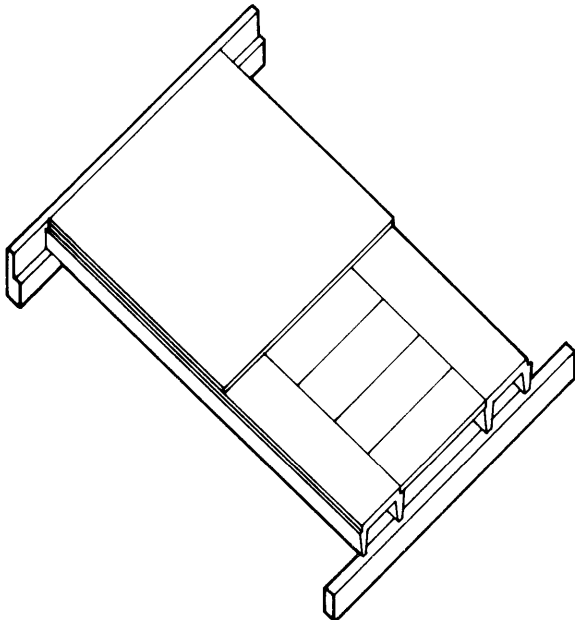

Keystone And Tee Joists

I. Types And Classifications

A. Varies with manufacturer:

KEYSTONE JOISTS

top width 6" - 9 1/4"
bottom width 3 1/4" - 7 1/2"
depth 6" - 18"
average weight 130 lbs./foot

TEE JOISTS

top width 8" - 16"
bottom width 2 1/2" - 5 1/4"
depth 8" - 20"
flange depth 1 1/2" - 4"
average weight 180 lbs./foot

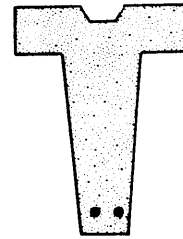

II. Structural Behavior

- A. The tee joist is capable of spanning further than the keystone joist.
- B. Once again, the relative strengths of the materials and the quantity of reinforcing steel used in the section may be varied to alter the load capacities of the elements.

III. Production And Construction

- A. Both joists are usually prestressed, precast concrete elements.
- B. The tee joist is usually the same as the double tee stem.
- C. Joists can be handled with lightweight equipment.
- D. Both joists are usually spaced 4' on center, but this also depends on the spanning capacities of the decking.

Application: Keystone And Tee Joist Systems

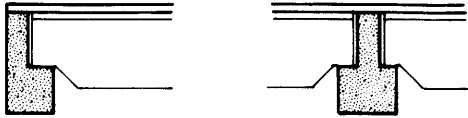
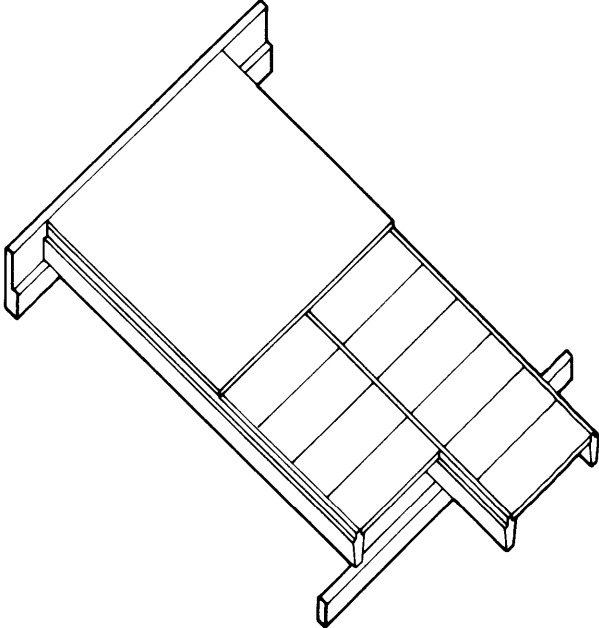

Section

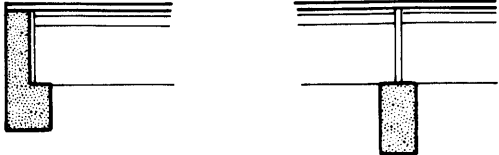
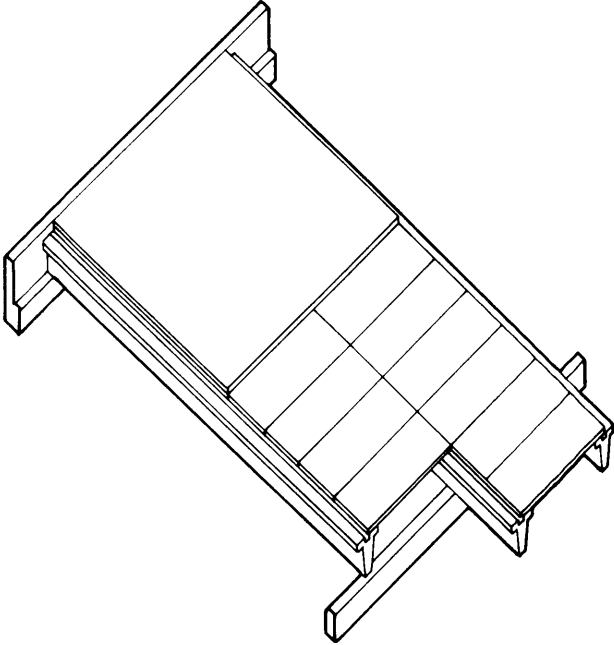
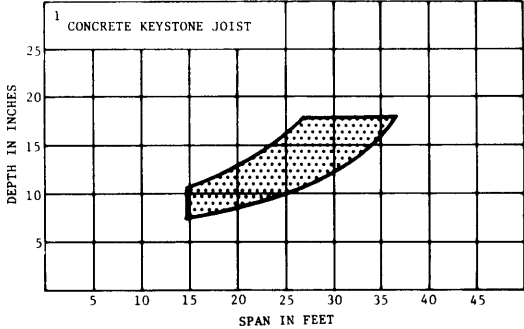
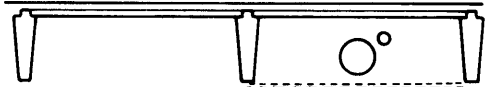

Section

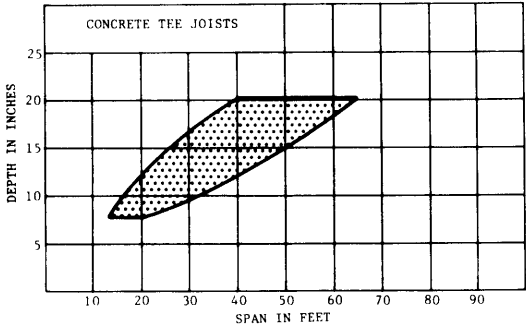

Ledger Beams

I. Types And Classifications

A. Varies with section:

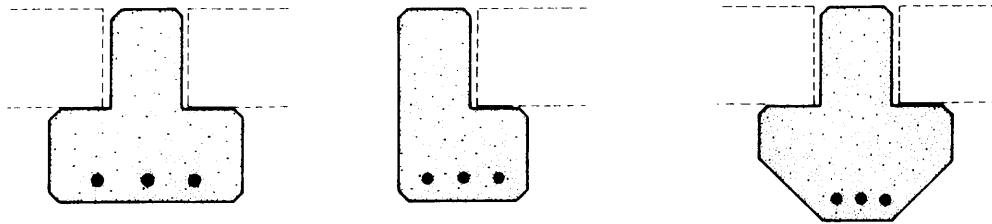

II. Structural Behavior

A. The critical aspect is the ledge or the corbel.

1. One must provide sufficient bearing surface for the decking elements to rest on. (usually 3" to 6")
2. One must also provide extra steel reinforcing in the haunch in order to transfer the tension and compression forces properly. If the ledge or haunch is overloaded, failure due to shear will result.

B. They behave similarly to singly or doubly reinforced concrete beams.

III. Production And Construction

A. To reduce the total depth of floor to roof construction, the tops of the beams are often made flush with the top surface of the decking elements.

1. Ledger beams--used for interior supports
2. 'L' beams--used for exterior supports

B. They are usually precast, prestressed concrete elements.

I And Box Beams

I. Types And Classifications

A. Varies with section

I BEAM

width 16" - 32"
depth 28" - 72"

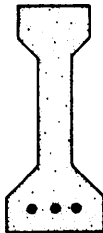

BOX BEAM

width 36" - 48"
depth 27" - 42"

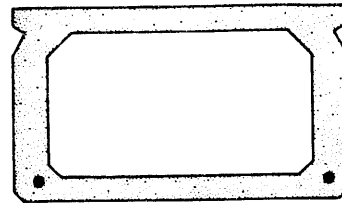

II. Structural Behavior

- A. These elements are usually for extra heavy construction and for special applications where applied loads are very large.
- B. Both are very efficient in resisting bending moments.
- C. The relative strengths of the materials and the quantity of reinforcing steel used in the section may be varied to alter the load capacities of the elements.
- D. Spacing of the elements depends on the spanning capacities of the decking.

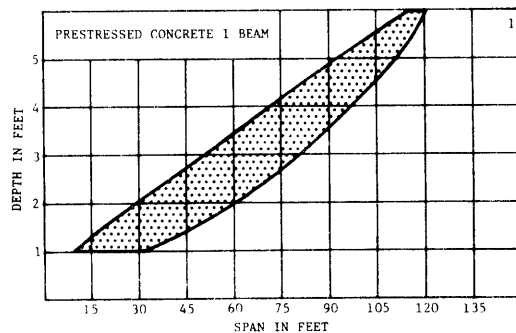

Steel Beams

Traditional Sections

I. Types And Classifications

A. Varies with section:

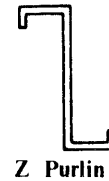
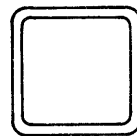
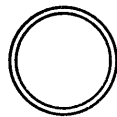
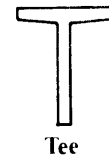
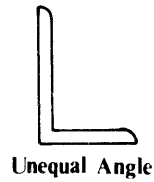
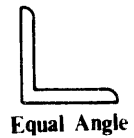
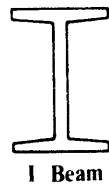
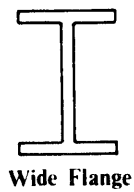

B. Varies with method of fabrication

1. Hot rolled sections
2. Cold rolled sections

C. The American Institute of Steel Construction Manual provides:

1. Dimensions for detailing
2. Properties for designing
3. Properties of sections

II. Structural Behavior

A. Instability of steel beams

1. Lateral instability--the compressive flange buckles out of the horizontal plane causing torsional failure.

Means of prevention: by increasing the section's resistance to bending and torsion or by providing lateral bracing.

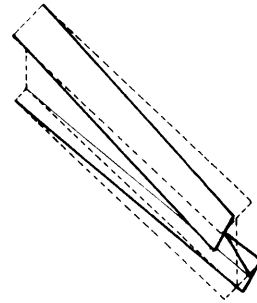

2. Local flange buckling--the compressive flange lacks sufficient area to resist compressive stress. Means of prevention: by increasing the dimensions of the compressive flange.

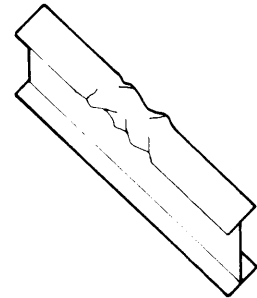

3. Local web crippling--the tendency of the web to buckle due to a concentrated load or support. Means of prevention: by providing web stiffeners at points of critical loading.

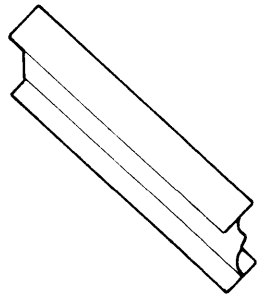

III. Production And Construction

- A. Structural steel is normally cut, shaped, and drilled by a fabricating shop before it is transported to the site.
- B. These beams require fire-resistant protection based on code requirements and, if exposed, treatment against corrosion.
(exception: corten steel)

Application: Steel Beam System

1. Beam to beam or beam to column connections consist of steel angles and/or plates which are fastened by either welding, bolting, or a combination of both.
2. Beam to wall connections require the use of steel bearing plates to distribute the load so as not to exceed the bearing capacity of the wall material.
3. Spacing of the beams depends on:
 - a. The design load for the beam depth and span
 - b. The allowable deflection
 - c. The spanning capacities and dimensions of the decking material.
4. A fire-resistance rating can be achieved by either covering the individual steel beam or by the flooring and ceiling material.

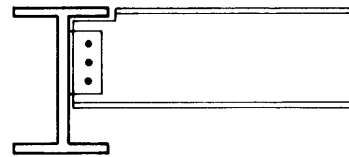
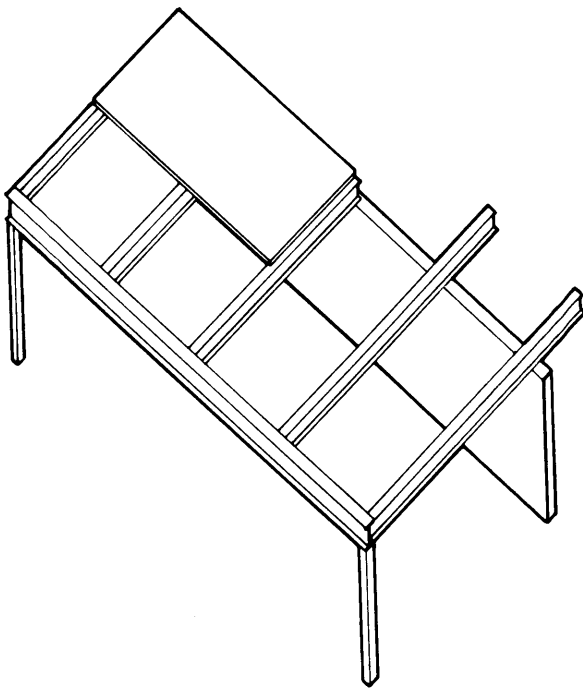

End Condition

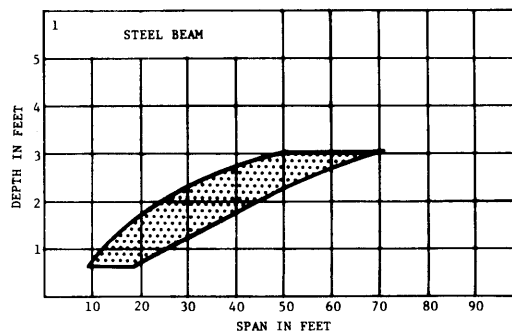
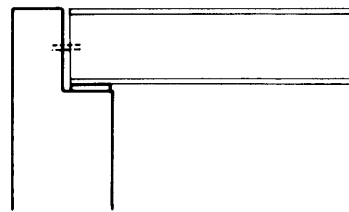

Made Up Sections

I. Types And Classifications

- A. Many additional shapes can be fabricated from basic rolled sections by combining two or more steel elements.
- B. They vary according to their resulting profiles and sections.
 - 1. Castellated beams
 - 2. Built up sections
 - a. Locally
 - b. Over the entire length
 - 3. Plate girders

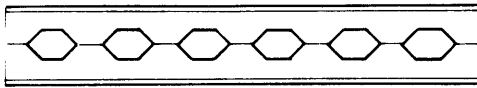
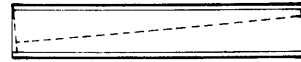
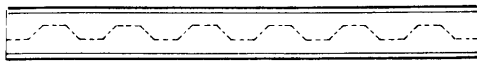

Castellated Beam

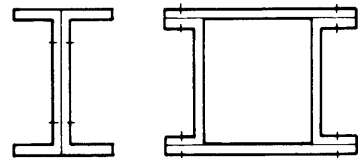
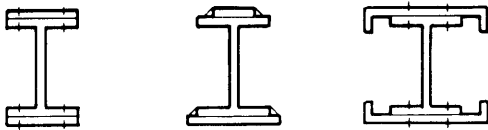
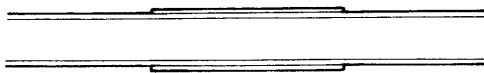

Made Up Sections

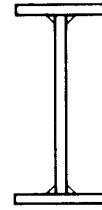
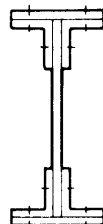

Plate Girder

II. Structural Behavior

- A. Fabricated sections result from an understanding of a particular loading--the designed section is more efficient than a standard shape in terms of transferring a given load.
- B. These beams usually respond to requirements of strength, rigidity, economy, and from dimensional needs and limitations.
- C. When the flanges and web(s) of a beam are made of separate elements, the connections between them have to resist tangential forces along the lines of their connections.
- D. When sections are built up, the resulting sections acquire different rigidity coefficients. (i.e. a new moments of inertia)

III. Production And Construction

- A. Critical factors in the fabrication of a made up section include:
 - 1. Necessary tolerances and clearances
 - 2. Ease of assembly
 - 3. Economy of material, fabrication, and maintenance
- B. Connections between elements are achieved by either welding or bolting.

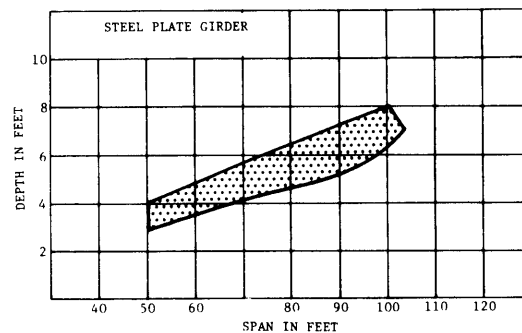
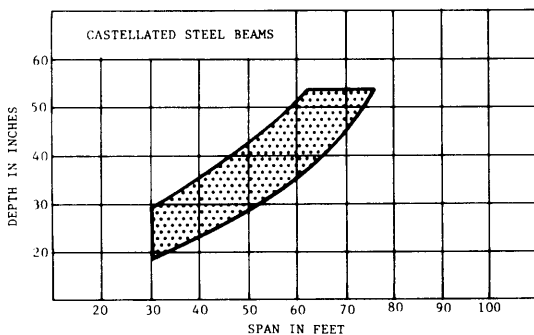

Open Web Steel Joists

I. Types And Classifications

A. Varies with manufacturer:

TYPES	DEPTHS	SPANS
standard: J series H series	8" to 30"	up to 60'
longspan: LJ series LH series	18" to 48"	up to 96'
deep longspan: DLJ series DLH series	52" to 72"	up to 144'

B. The primary difference in a J and a H series is the strength of steel used.

1. J series: the yield strength = 36,000 psi
2. H series: the yield strength = 50,000 psi

C. An open web steel joist's section may vary according to manufacturer.

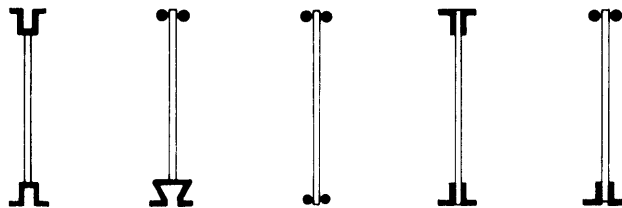

D. The web system and profile also vary with manufacturer.

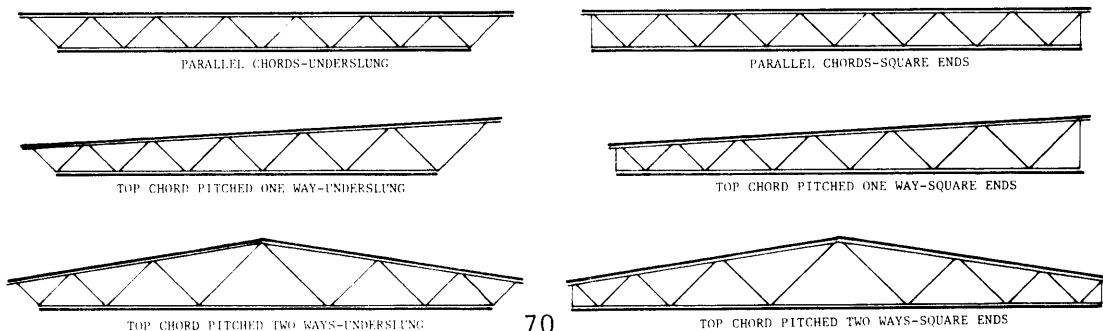

II. Structural Behavior

- A. Since open web joists are pre-engineered, one should consult the Steel Joist Institute Handbook or manufacturer's catalogs for specifications and complete load tables for all joist types and sizes.
- B. The top and bottom chords act primarily as a moment mechanism while the diagonals and any sloped chords act as a shear mechanism.

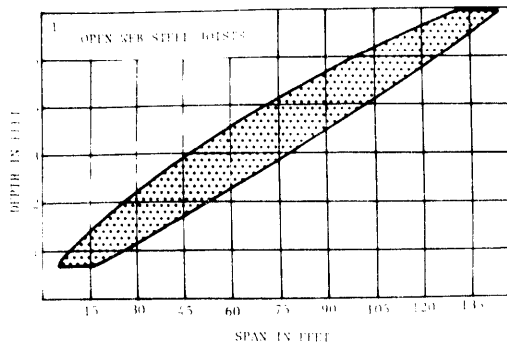

III. Production And Construction

- A. Short span joists are almost entirely mass produced by computer automation. The web is a continuous solid bar, bent to panel configuration, and welded directly to a bent chord member or between double angles or double bar chords.
- B. Joists are produced with a positive camber so that, under loading, they will deflect into a level plane.
- C. Additional accessories are available through a manufacturer.

Application: Open Web Steel Joist System

1. Mechanical systems may be located parallel or perpendicular to the open web steel joists.
2. Ceiling finish may be attached directly to the joists or suspended from the bottom chords if additional space is required.
3. The fire rating of the system depends on the fire rating of the ceiling or flooring material.
4. The spacing of the joists is related to:
 - a. The type and size of loading
 - b. The desired construction depth
 - c. The spanning capacities of the decking material
5. Transversal bridging is required to prevent lateral movement of the top or bottom chords.
6. A joist which is supported by the top chord may be cantilevered limited amounts by extending the top chord.
7. An open web steel joist system works most efficiently with uniform loadings.
8. One must distribute the load transferred from the joist to the support so that it will not exceed the unit bearing capacity of the supporting material.
 - a. For concrete walls--4" to 9"
 - b. For steel beams--2 1/2" to 4"

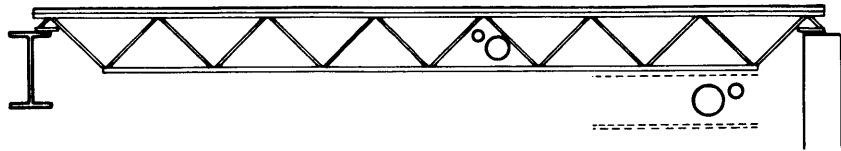

Elevation

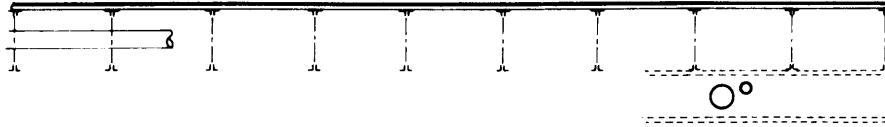

Section

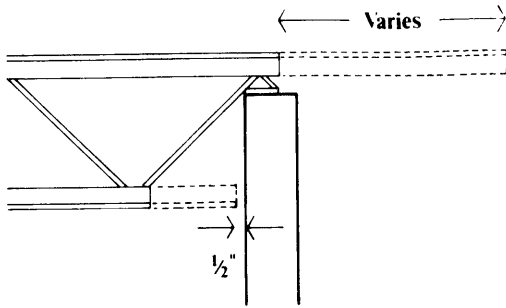

End Condition

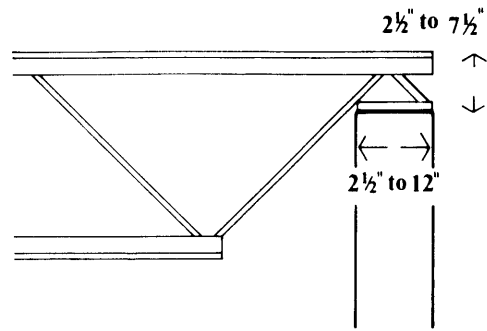

End Condition

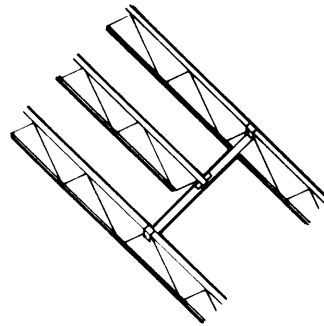
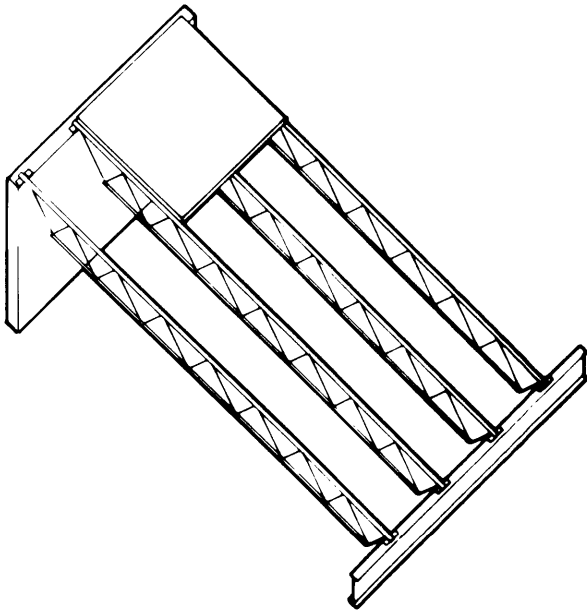

3

Lightgage Joists

I. Types And Classifications

- A. Varies with section
- B. Varies with gage of steel used--12 through 18

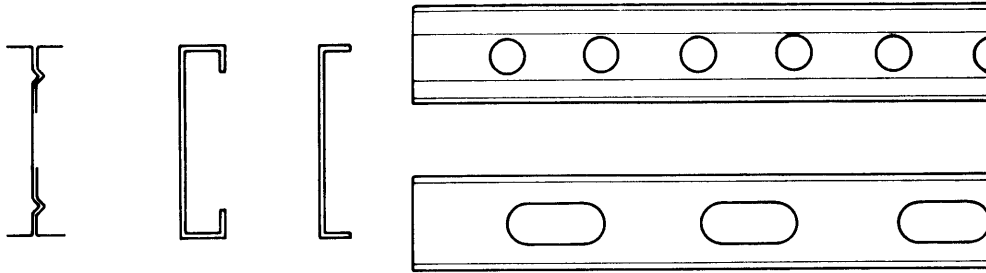

II. Structural Behavior

- A. Web stiffeners are required to prevent crippling of the web.
- B. Lateral stability is achieved by:
 - 1. Bridging between joists
 - 2. Framing joists into channel beam at their ends
- C. This element is suited for light loads and short spans.

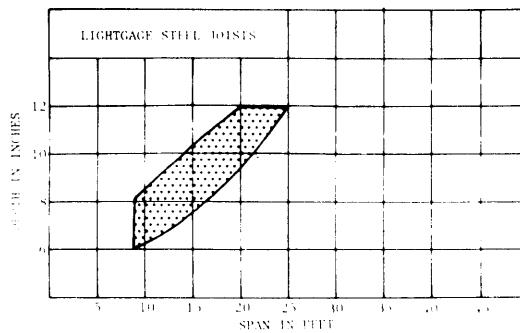

III. Production And Construction

- A. Punched holes in the web reduce the weight of the joists and provide space for small plumbing or electrical lines,

- B. Connections are welded, bolted, or screwed.
- C. This system is similar to a wood joist system.
- D. Cantilevers are possible.
- E. Fire rating of the system depends on the applied finishes.
- F. Spacing of the joists is a function of the spanning capacities of the decking used.

Application: Lightgage Joist System

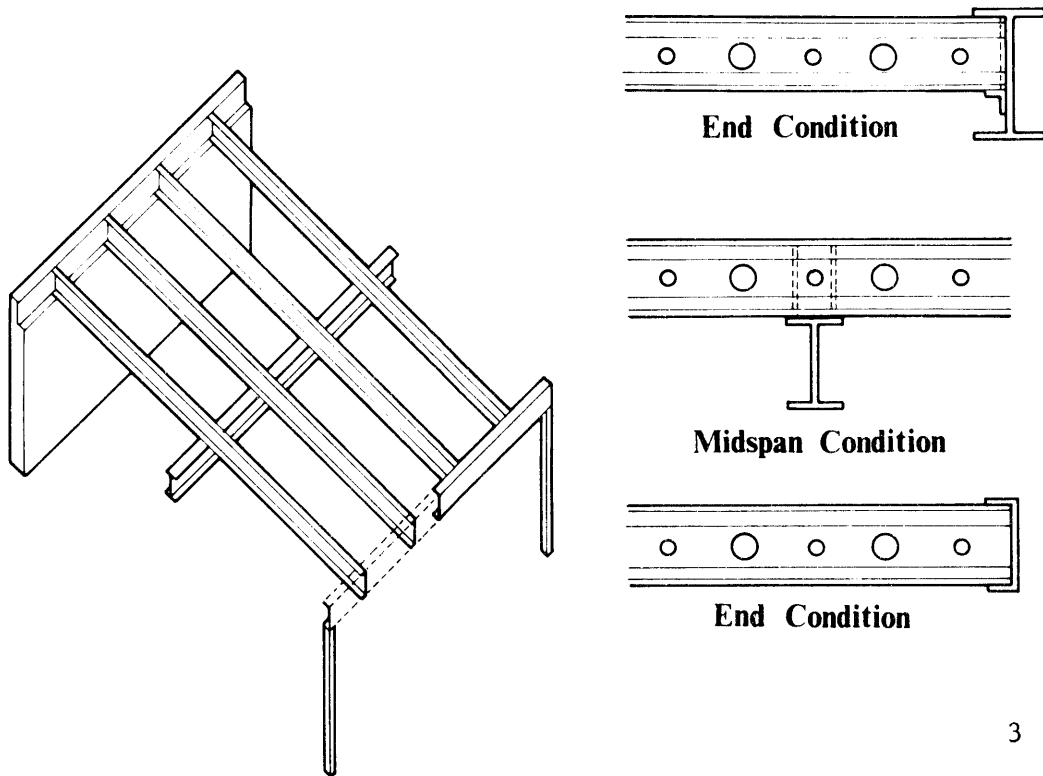

FOUR

Trusses And Space Frames

Theory Of Trusses

Definition: A truss is a load carrying mechanism in which the loads are redirected through a set of members which have only axial tension or compression forces.

I. Types And Classifications

A. A typical truss is composed of a framework of the following members.

1. Top chord
2. Bottom chord
3. Web members
4. Panel points

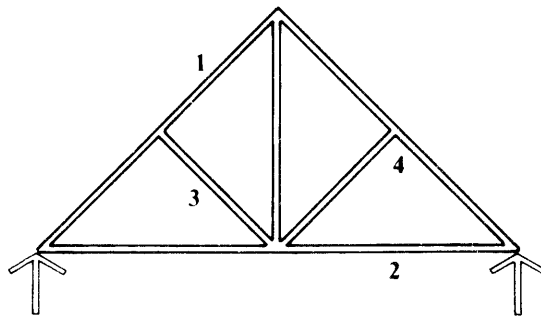

B. While all trusses share the same basic load mechanisms, they are usually classified according to the disposition of their members.

1. Trusses are categorized by their chord placement.
 - a. Planar systems--parallel chords, curved top chords, and sloped top or bottom chords
 - b. Spatial systems--top and bottom chords not aligned vertically
2. Trusses are categorized by the geometry of the framework.
 - a. Planar systems--triangulated
 - b. Spatial systems--tetrahedral subdivisions

- C. It should also be noted that trusses can be used as the secondary structural mechanism for other primary structural systems.

Examples: trussed arches or trussed frames

II. Structural Behavior

A. Bending and shear

1. Like the beam, a truss develops a bending mechanism in order to transfer the load.
2. For example, the resisting bending moment in a parallel chord truss is produced by a couple--two equal and opposite forces which act along parallel lines and separated by a distinct distance. The top chord provides a compressive force, while the bottom chord provides a tensile force of equal magnitude. The depth of the truss supplies the lever arm.

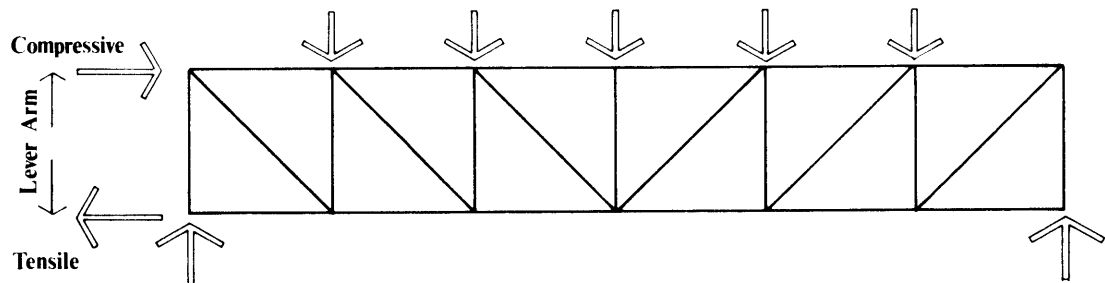

3. The diagonals (including any sloped chords) act primarily as a shear mechanism.

B. Stability

1. Since a truss is geometrically stable, secondary stability considerations include:
 - a. Out of the plane stability--one must maintain the truss in its plane of action. This may be accomplished by cross

bracing or by fastening roof or floor decking to the truss. Cross bracing also restrains the compression chord of the truss.

- b. Compression member stability--one must prevent premature buckling of the compressive elements. A critical factor in the sizing of these members (both the chord and the web members) is the unsupported length of the elements.
- c. Joint stability--one must prevent failure due to shear and/or bending forces at the joints or panel points resulting from uniformly loading a chord. Since joints in trusses are rarely simple pin connections, there will be stresses in the members as the system deflects.

C. Assumptions for analyzing most trusses

- 1. All joints are pin connections--for ease and economy of construction, this is almost never true.
- 2. All members are straight between joints or panel points--true except in bowstring trusses.
- 3. Trusses are almost always designed as a simple span member.
- 4. Usually a truss will be loaded only at the panel points, but many trusses will have a chord loaded continuously. For the latter case, the chord must be designed as both a bending member and as an axial member in either compression or tension.

D. Methods of analysis

- 1. Method of sections
 - a. Solve for external reactions
 - b. Cut truss at various sections
 - c. The internal forces required for equilibrium are the member

forces.

- d. This is an excellent method for checking internal forces.

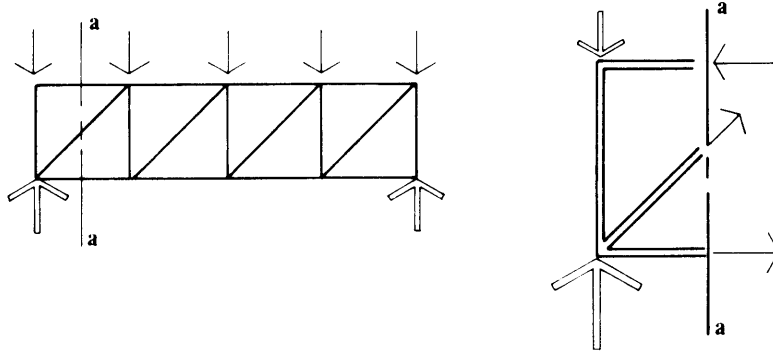

2. Method of joints

- a. Solve for external forces.
- b. Solve for the forces at a joint by using the basic equations of statics.
- c. Proceed joint to joint, using already solved forces as one proceeds.
- d. This method lends itself to computer analysis.

3. Graphical analysis

- a. Determine member forces by graphic resolution of joints.
- b. This is the graphic abstraction of the previous method.

E. Typical design guidelines

1. Spacing of trusses

- a. Usually the wider the spacing, the deeper but more economical the truss.
- b. Truss spacing is a function of the flooring or roofing material--if they are fastened directly to the truss (the top or bottom chords would then be uniformly loaded and must be designed for resistance to bending as well as for

an axial load), the spacing depends on the spanning capabilities of the decking material. If they are fastened to purlins which then transmit the load to the truss (purlins should always fall at the panel points in order that the chords be designed only for axial forces), then a wider spacing can be achieved.

2. Panel spacing

- a. This is a function of the load, span, and depth of the truss.
- b. Panel spacing is usually from 4' to 10', but the most efficient spacing occurs when the diagonal webs are located at an angle of 45° with respect to the chords since a more uniform magnitude of loads are achieved in the compression and tension members.

3. Dimensioning of the individual members

- a. One must use the basic relationships of stress and strain for axially loaded members
- b. See beam theory section for sizing members in bending.

Wood Trusses

I. Types And Classifications

A. Trusses are classified by their method of construction

1. Type of joints

2. The physical properties of the wood member(s) used.

B. Trusses are classified by the geometry of their framework.

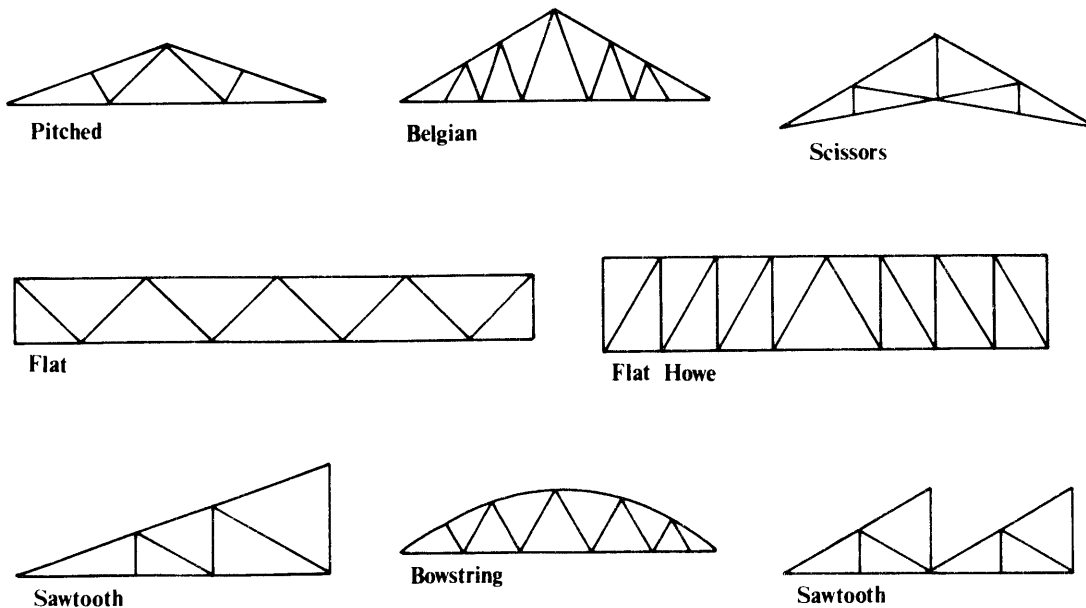

II. Structural Behavior

A. For light loads and short to medium spans, manufacturer's data will describe the standard trusses available.

B. The dimensions of the members are usually relatively uniform and based on the member with the largest stress--this simplifies

details in connections.

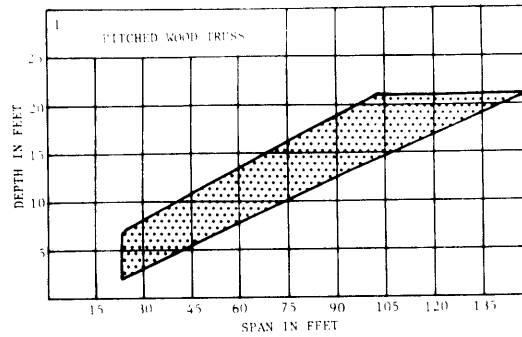
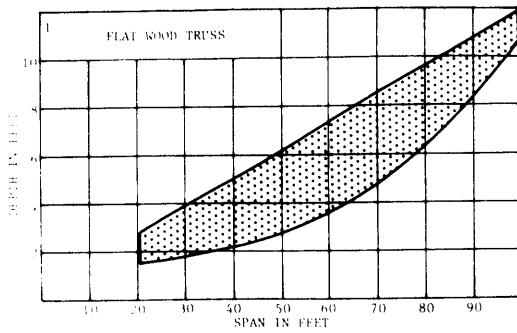

III. Production And Construction

- A. Manufacture of light wooden roof trusses has become universal.
One should see Manufacturer's catalogs.
- B. Trusses are almost exclusively shop fabricated, which allows for rapid field erection.
- C. When transporting trusses, one must consider allowable size limitations, however long trusses can be field spliced.
- D. Trusses can be constructed of either single or double members, however multiple piece members are commonly used so as to obtain more efficient connections at joints and enable smaller sections of wood to be employed.
- E. Connections are usually of two types.
 1. Ganged nailed--popular in light residential trusses--used with single members.
 2. Bolted and split ring connections--typically used with long span, multiple member trusses.
- F. Wood trusses can accommodate insulation and mechanical or electrical lines within their depths.

Steel Trusses

I. Types And Classifications

- A. There exists basically two types
 - 1. Planar systems--similar to those found in wood trusses.
 - 2. Spatial systems--commonly known as a steel space truss.

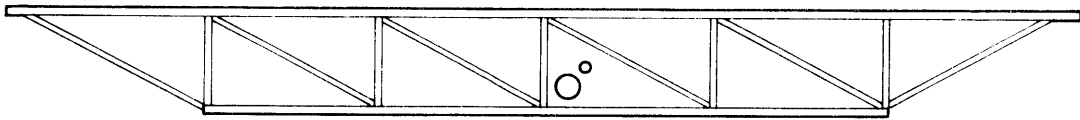

Elevation

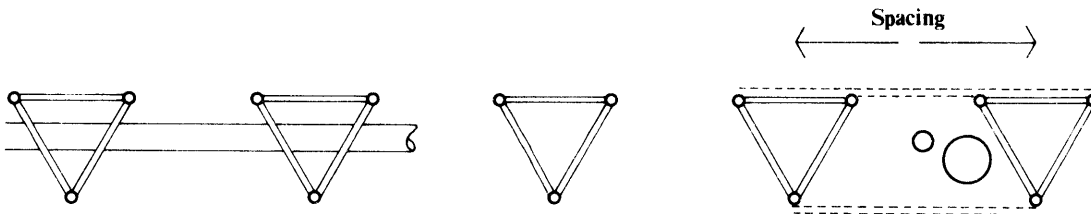

Section

II. Structural Behavior

- A. Steel trusses are efficient in medium to long spans.
- B. They possess a good span to weight ratio.
- C. Like all trusses, their spanning capacities vary with the geometry configuration of the framework, the depth, and the load conditions.

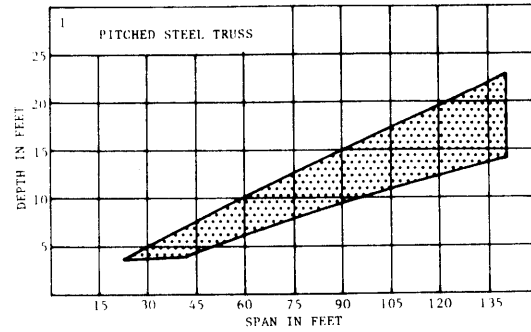
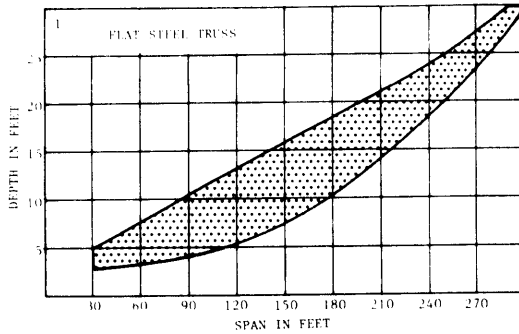

III. Production And Construction

- A. Their open webs allow passage of other systems.
- B. The orthogonal nature of most types works well with flat roofs or floors.
- C. A building's interior spaces are flexible in design due to the clear spans of the trusses.
- D. Direct fire-proofing is difficult, however an acceptable rating can be achieved through the use of a ceiling or flooring material.
- E. Lightness can result in floors or roofs which are too flexible.
- F. Steel trusses will use double angle webs, directly welded to a tee or double angle chord, or to a gusset plate welded in turn to the chord. Welding has become the most typical connection, although some trusses are still bolted or riveted.
- G. Fabrication is almost exclusively in the shop, with only erection and lateral bracing typically occurring in the field. Large trusses are typically fabricated in the shop to the largest possible transportable sizes.

Concrete Trusses

I. Types And Classifications

A. Varies with manufacturer

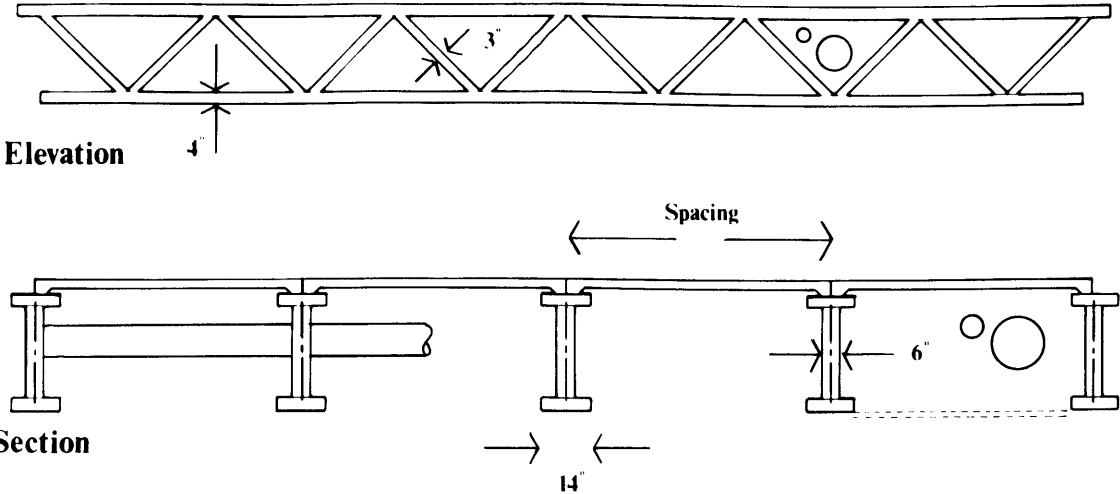

II. Structural Behavior

- A. See manufacturer's data
- B. The spanning capacities vary with the spacing and depths of the trusses.

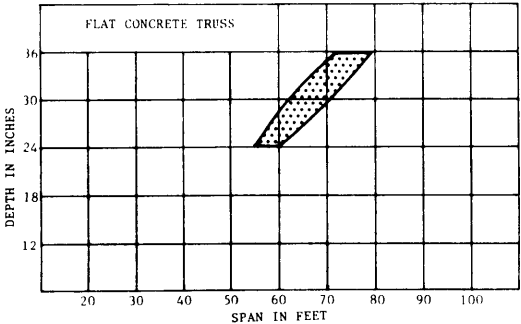

III. Production And Construction

- A. A major advantage of the concrete truss is that the joints are virtually eliminated since the members are monolithically cast as one.
- B. Concrete trusses have the advantage of resisting fire and deterioration.
- C. Weight is a disadvantage, but is balanced by the efficiency of the member.
- D. These trusses are always precast, prestressed in a factory.
- E. Concrete trusses are primarily used for roof spans.

Theory Of Skeletal Space Frames

Definition: Skeletal space frames are three dimensional trusses composed of bars or struts connected at nodes.

I. Types And Classifications

- A. Classified by kinds of supports (see following sheet)
- B. Classified by orientation or direction of space frame in relation to the perimeter

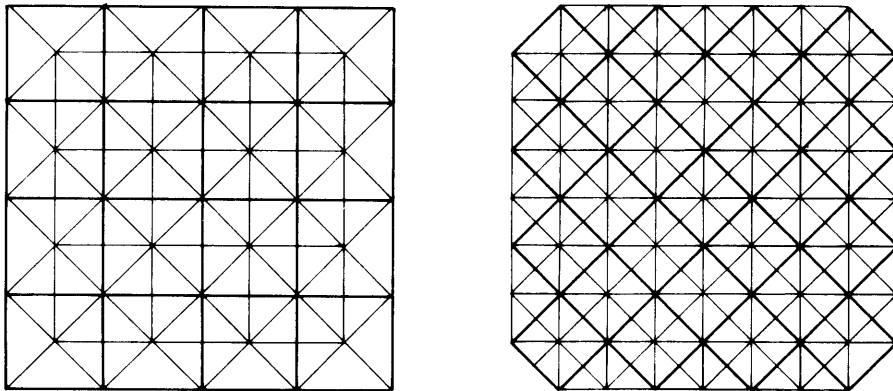

- C. Classified by orientation and geometry of the top and bottom grids.
 1. Direct grid
 - a. Top and bottom grids are geometrically identical.
 - b. Top grid is located directly over bottom grid.
 2. Offset grid
 - a. Top and bottom grids are geometrically identical.
 - b. Top grid is offset in relation to the bottom grid.
 3. Differential grid

- a. Top and bottom grids are geometrically different and therefore directionally different.
 - b. Bracing between grids is located at points where their geometries coincide.
4. Lattice grid
- a. Top and bottom grids are geometrically identical.
 - b. Bracing between grids occurs more frequently than in the direct grid.

II. Structural Behavior

- A. External loads are transferred multidirectionally along the components in three or more directions.
- B. The actual load distribution of the space frame depends on the type of supports. The overall action of the system may be either one way, two way, or multidirectional.
- C. The overall strength of the skeletal space frame is a function of the strength of the compressive members.
- D. The members are primarily axially stressed if loads occur at the panel points.
- E. Because of the high indeterminacy of these systems, failure of one member does not necessarily lead to a failure of the entire system.
- F. Cantilevers are possible and are usually $1/4$ of the span.
- G. Due to the complex structural behavior of skeletal space frames, one must consult manufacturer's literature or use a computer to analyze them.

Types Of Skeletal Space Frames

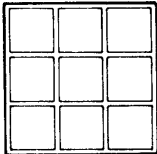
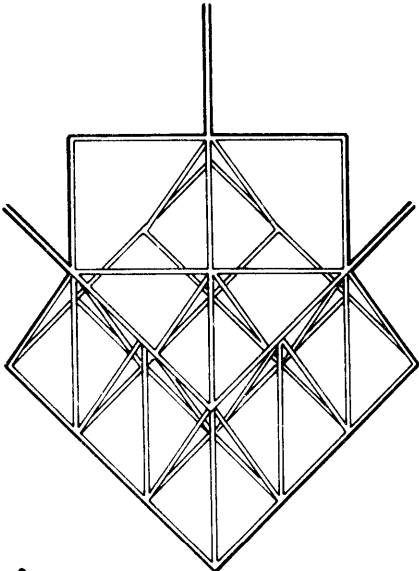
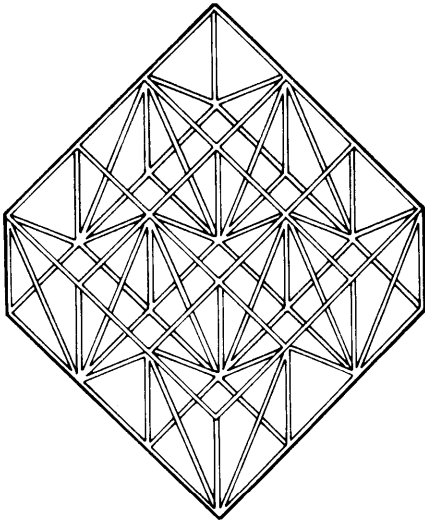

Direct Grid

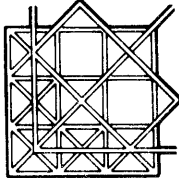

Differential Grid

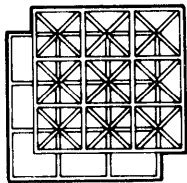
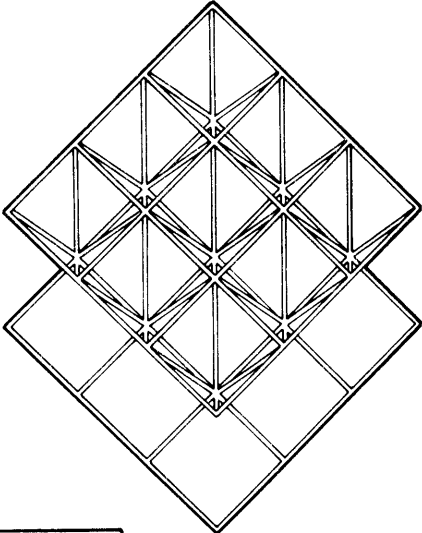

Offset Grid

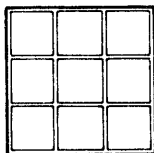
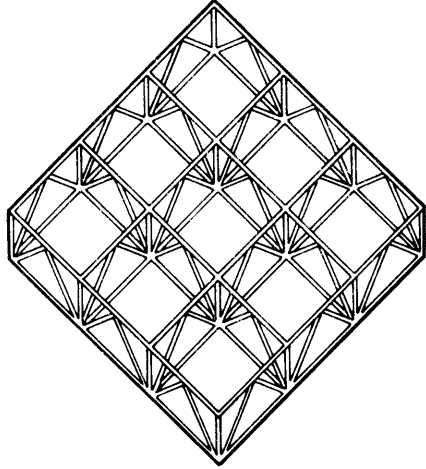

Lattice Grid

Types Of Supports

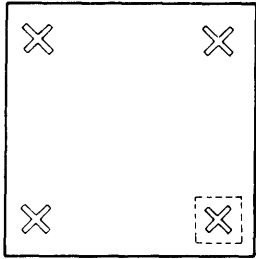

4 Point Cruciform Support

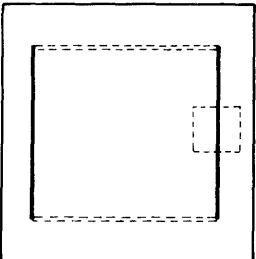
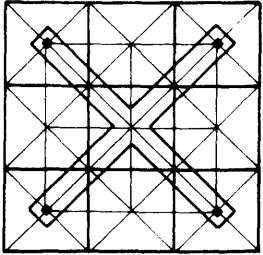
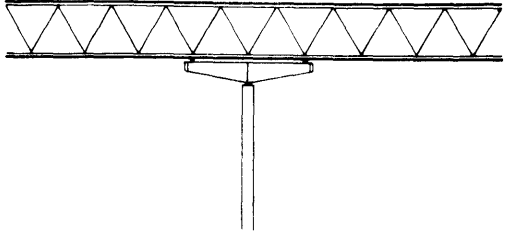

Wall Or Beam Support

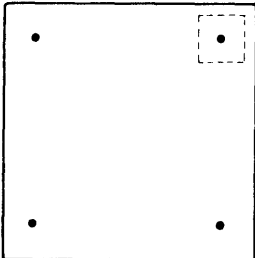
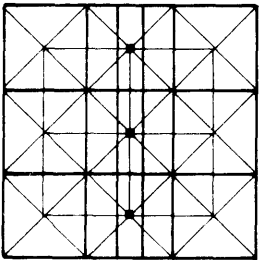
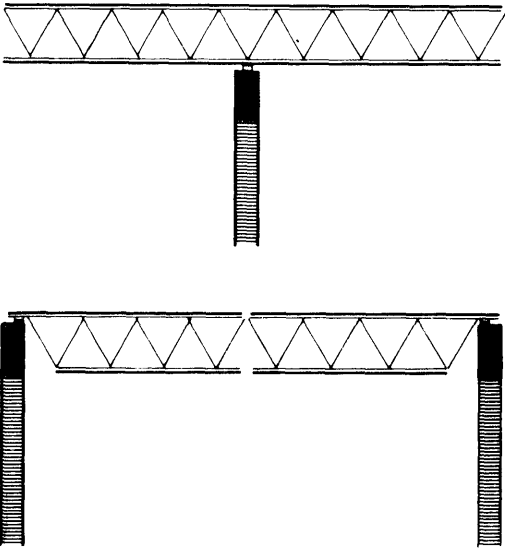

Column Support

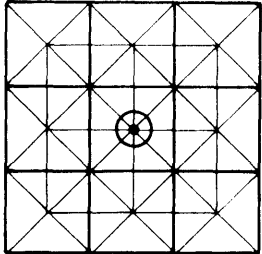
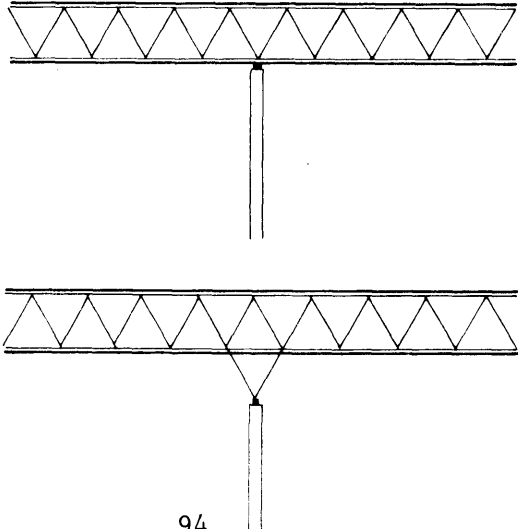

Steel Skeletal Space Frames

I. Production And Construction

- A. A skeletal space frame (to be economical) is a function of:
 1. Maximum shop fabrication
 2. Ease and economy of transportation of pre-assembled units
 3. Minimum number of units and connections
- B. The joint in a skeletal space frame (to be economical) is a function of
 1. The type and size of the members--common types include: angles, structural tubing, channel shapes, structural tees, and wide flange sections
 2. The members geometric relationships
 3. The method of connection--common methods include: bolting, welding, and special connectors
- C. Space frames provide ample space for the installation of mechanical systems while also providing flexible interior planning.

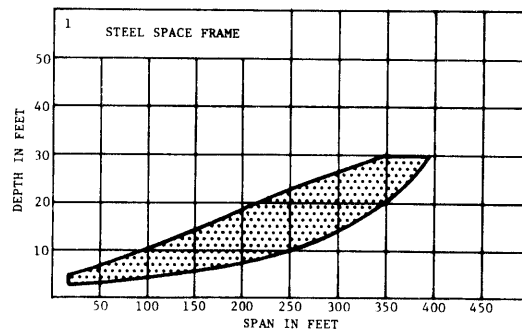

Concrete Skeletal Space Frames

I. Production And Construction

A. A typical construction sequence

1. The structural elements are formed. These elements may be either precast concrete pentahedrons or tetrahedrons.
2. Precast elements are set in place.
3. The post-tensioning reinforcing is positioned.
4. The bottom grid between the elements is grouted.
5. The precast floor panels are set in place.
6. A concrete topping is poured and allowed to cure.
7. The system is then post-tensioned in two directions.

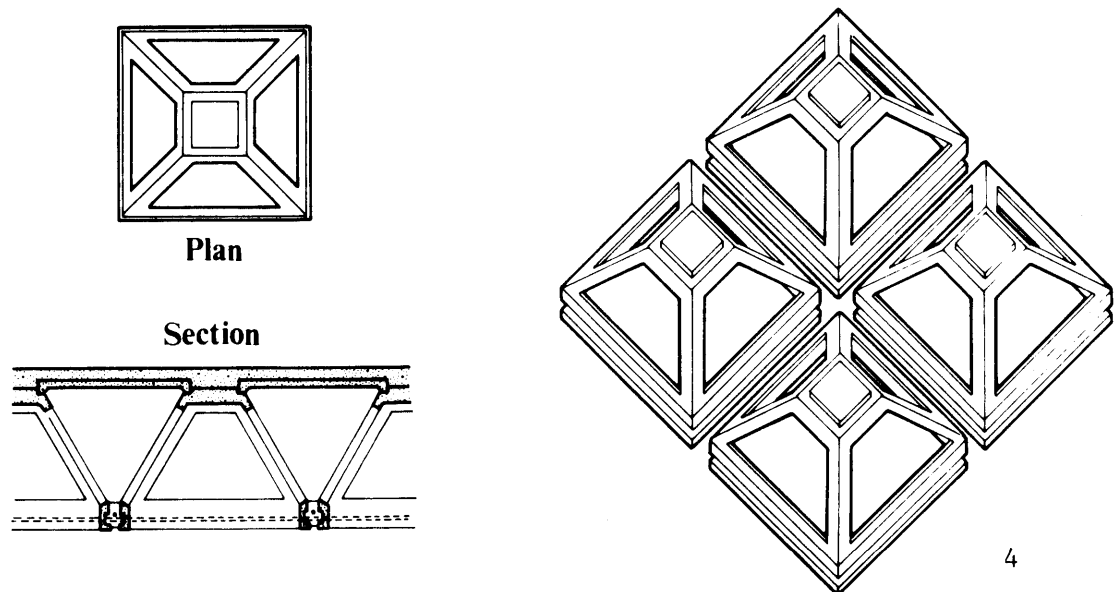

Application And Theory Of Stressed Skin Space Frames

Definition Stressed skin space frames are frames in which the bracing is achieved by thin sheets instead of linear elements.

I. Types And Classifications

- A. Varies with shape or geometrical configuration
- B. Varies with type of support
- C. Varies with the direction in which the apexes of the elements are pointed

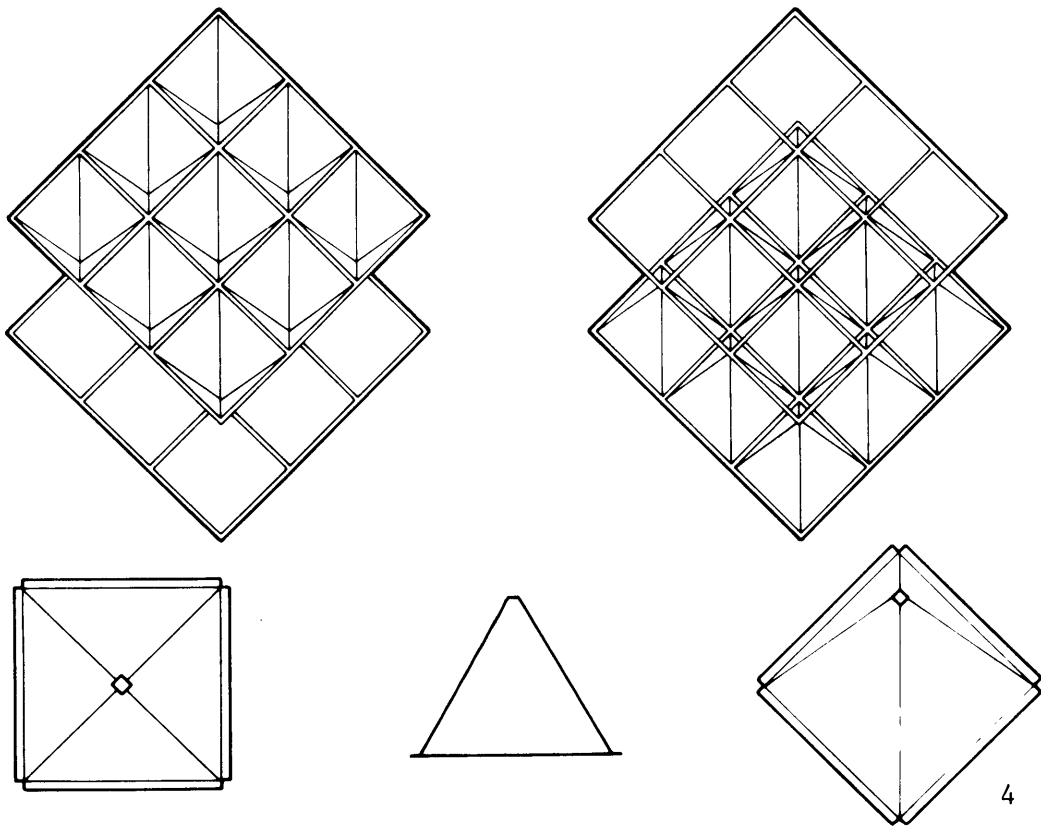

II. Structural Behavior

- A. The compressive edges of the sheets are prevented from buckling by the lateral restraint provided by the adjacent sheets.
- B. Loads are transferred into the plane of the sheets and therefore bending stresses are negligible.
- C. Stressed skin space frames can be supported by columns, walls, or beams. The use of cantilevers is possible in order to obtain more uniform stress distributions.

III. Production And Construction

- A. The system consists of three elements.
 - 1. The pyramids
 - 2. The prefabricated tie members
 - 3. The connectors
- B. The pyramids are prefabricated units composed of either sheets of galvanized steel or plywood. The bases of these three dimensional units are either triangular, square, or hexagonal.
- C. Each unit has flanges along their bases in order to allow adjacent units to be joined together.
- D. The apexes of the units are interconnected by prefabricated tie members to form a regular geometric grid.
- E. A stressed skin space frame not only transfers the load, but also serves as a covering.
- F. The three dimensional units can be transported easily by stacking.
- G. The stressed skin pyramids also display good acoustical properties by acting as sound baffles.
- H. The pyramids may also be composed of sheets of transparent plastic.

FIVE

Arches And Frames

Theory Of Arches

Definition: An arch is a structural element which transfers a load to its supports by a compressive mechanism along a curve or polygonal line.

I. Types And Classifications

- A. An arch varies with the geometry of its profile.
 - 1. The number and location of loads
 - 2. The rise
 - 3. The horizontal distance between the supports
- B. An arch system varies with method of resisting the horizontal thrust.

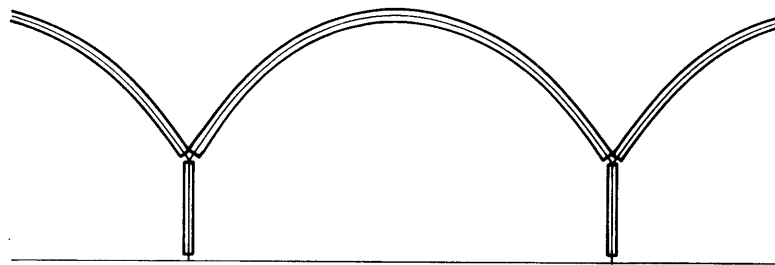

Adjacent Arches

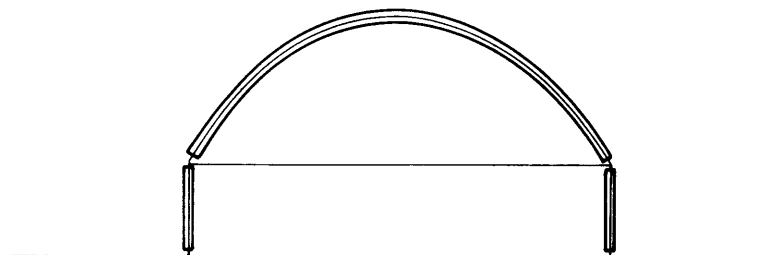

Ties

2

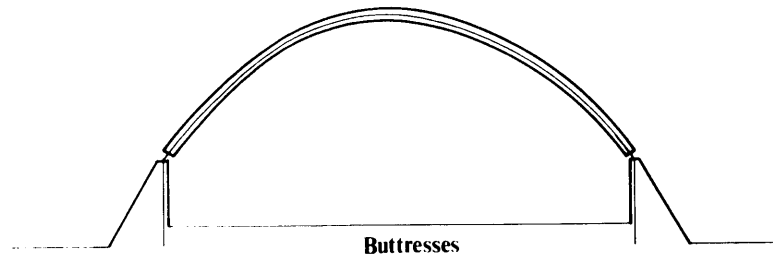
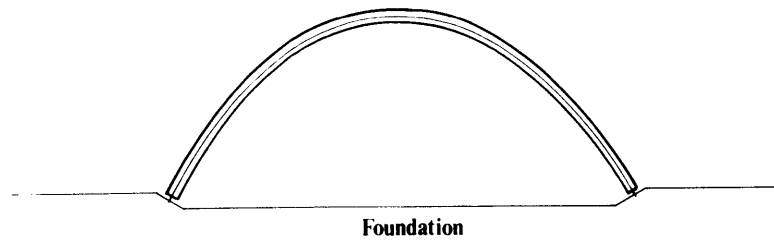

2

II. Structural Behavior

A. There are three types of structural classifications of arches.

1. A fixed arch

- a. The arch is rigidly connected to the foundation.
- b. It is statically indeterminate.
- c. Each base possesses a horizontal and vertical reaction in addition to a bending moment.

2. A two hinged arch

- a. The arch is supported at each end by a hinge.
- b. It is statically indeterminate.
- c. There are vertical and horizontal reactions at each end.

3. A three hinged arch

- a. This arch is similar to the two hinged arch with an additional hinge at the crown.
- b. It is statically determinate.
- c. The bending moments at the supports and crown are zero.

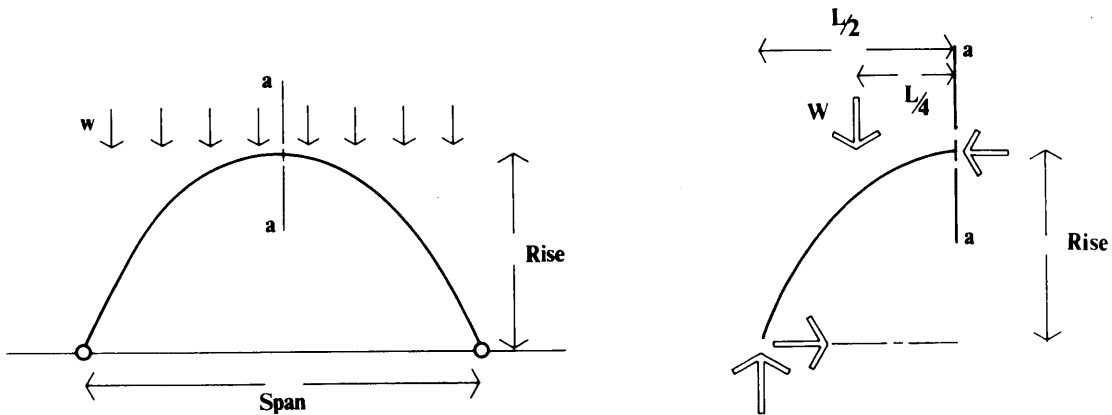

B. For a three hinged arch that is uniformly loaded:

1. $V = w (\text{span}/2)$
2. $H = w (\text{span}^2) / 8 (\text{rise})$
3. $H =$ the bending moment for a simple beam of the same span/rise
4. Where: $w =$ the load per unit length
 $H =$ the thrust
 $V =$ the vertical reaction
5. This method can be used to approximate the thrusts of two hinged arches which are slightly less.

C. Like a cable, the thrust of an arch is inversely proportional to its rise.

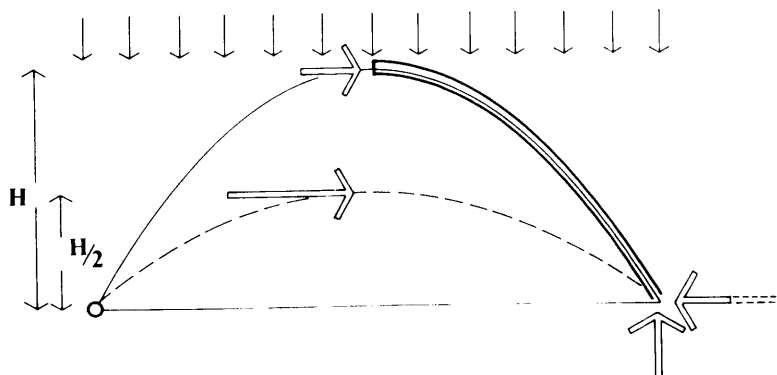

D. If the shape of the arch is identical and inverted to the curve or polygonal line of a cable similarly loaded, then the shape is referred to as the funicular curve or line of the arch.

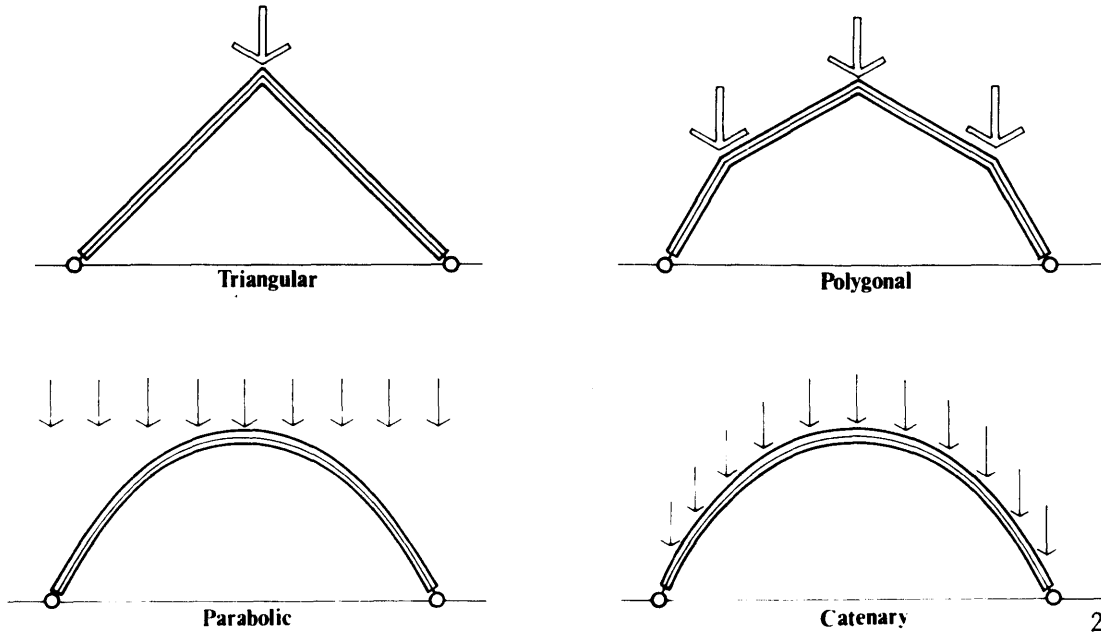

E. Bending moments are created within an arch when its shape deviates from the funicular curve or line of the loading.

F. Like a beam, a resisting moment is created by a force couple.

1. For the beam--the lever arm is located within the depth of the member.
2. For the arch--the lever arm is located outside the depth of the member.

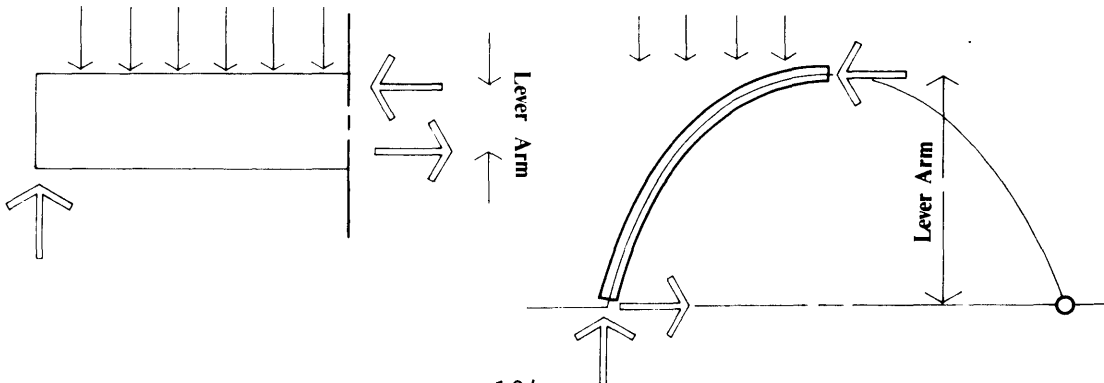

Wood, Concrete, And Steel Arches

I. Production And Construction

- A. The arches of the three materials are similar in nature.
- B. Shop fabricated components are available--one should contact manufacturers for sizes and transportation limitations.

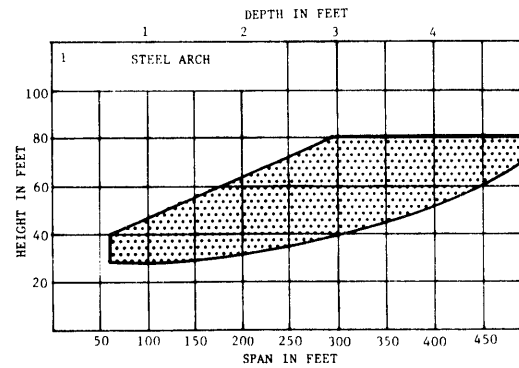
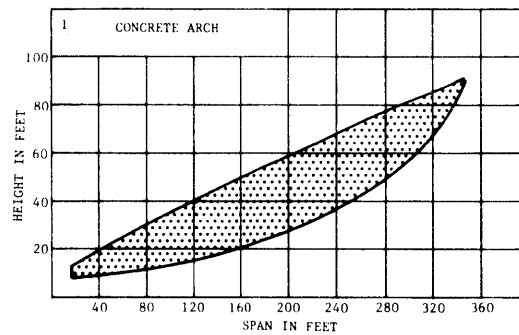
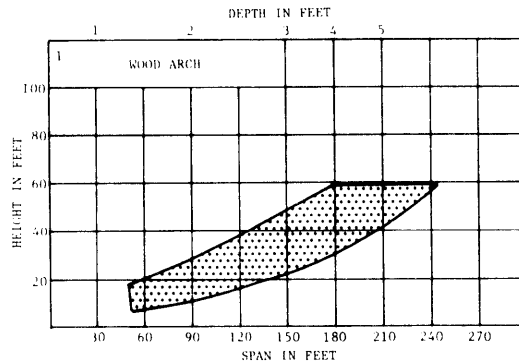

Lamella Arch

I. Types And Classifications

- A. Varies with section--the rise, the span, and the number of component elements
- B. Varies with the method of resisting the horizontal thrust--buttresses or horizontal ties

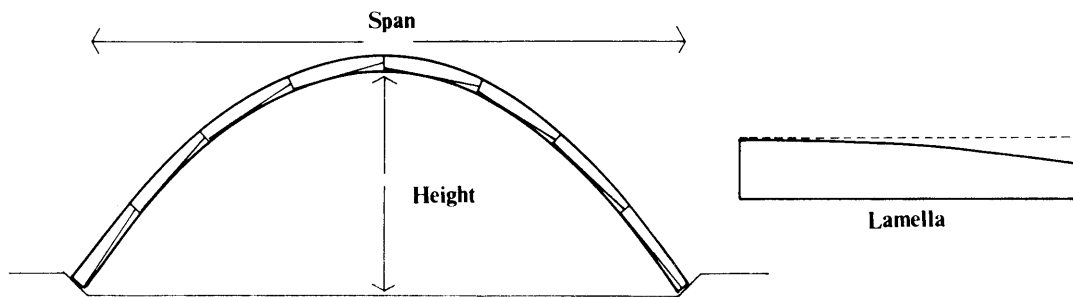

II. Structural Behavior

- A. A lamella arch system consists of two sets of parallel arches which intersect at skew angles. The system is similar to a curved skew grid.
- B. In section, the system is essentially a two hinged arch.
- C. End supports for the system are required and may be either a separate arch or a broached lamella arch.

III. Production And Construction

- A. The curve of the arch is obtained by cutting the upper edge of the lamella.
- B. A lamella arch system may be constructed in either steel, wood, or concrete. For the system to be economical, there must be a minimum number of units and connections, a maximum amount of shop fabrication, and ease of transportation of pre-assembled units.

Theory Of Frames

Definition: A frame is a planar system of elements which are connected by joints which are rigid.

I. Types And Classifications

- A. The simple frame--a horizontal beam which is rigidly connected to two vertical columns and is classified by the column support conditions.
1. A hinged frame--statically indeterminate
 2. A fixed frame--statically indeterminate
- B. The three hinged frame--similar to a two hinged simple frame, however there exists an additional hinge at the crown. This type of frame is statically determinate.
- C. The multi-bay frame--a horizontal beam which is rigidly connected to a series of columns.

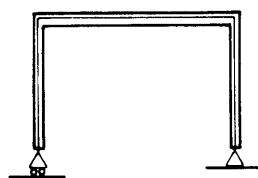

Two Hinged

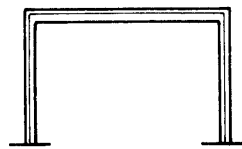

Fixed

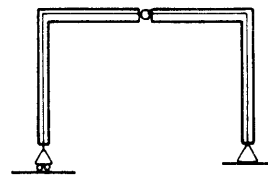

Three Hinged

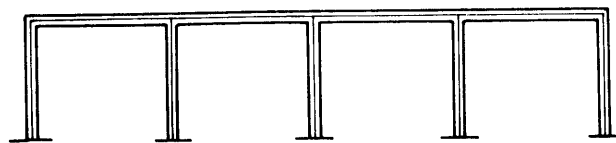

Multi-bay

II. Structural Behavior

- A. When uniformly loaded, the horizontal element of a rigid frame is capable of resisting a greater loading than a simple supported beam.
- B. The columns of a frame are subjected to both axial compressive stresses due to the load and bending stresses due to the moment transferred from the beam.
- C. In a rigid frame, the column is also subjected to a horizontal force which is required to maintain the frame in equilibrium.
- D. As the shape of a rigid frame is less rectangular (it approaches the shape of an arch), the bending moments, in general, decrease.
- E. A haunched knee in a frame increases the moment at the knee while decreasing the moment at midspan.

Relationship Between Amount Of Haunch And Corresponding Moment At Midspan

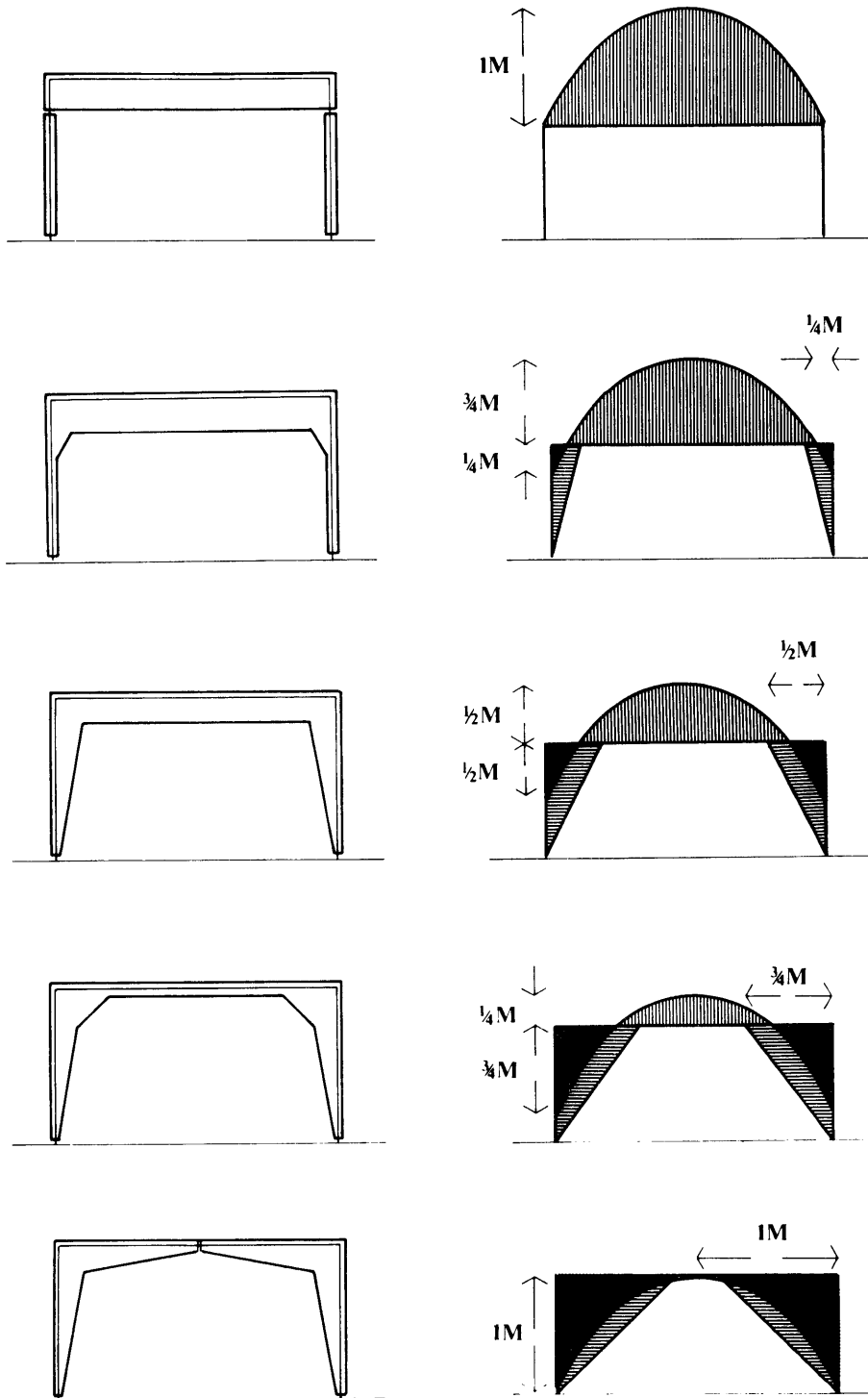

Wood Frames

I. Types And Classifications

A. Varies with profile

1. A-frame
2. Tudor frame

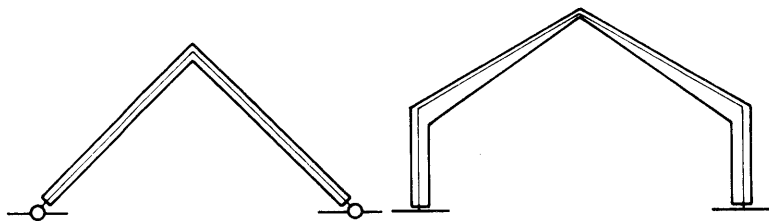

B. The column height and the pitch of the arms may also be varied.

II. Structural Behavior

A. Manufacturer's catalogs contain the structural properties of the available glue laminated wood frames.

B. The critical dimensions of a tudor frame include:

1. The radius of the knee--must be within manufacturer's limits
2. The depth of the knee--ample section to resist moment
3. The depth of the crown--ample section for connections
4. The spacing of the frames--in order to determine loading

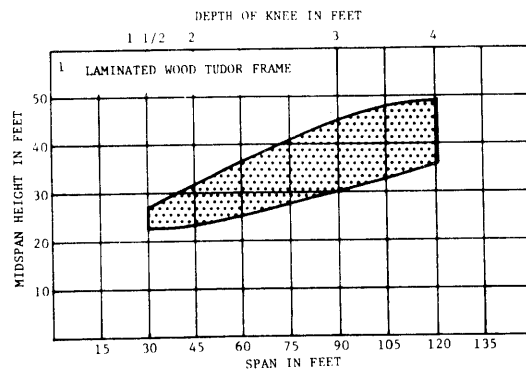

III. Production And Construction

- A. Two hinged and fixed frames are less common than three hinged frames because:
 - 1. They are more difficult to transport and erect.
 - 2. They have more complex foundations.
 - 3. The crown connection to take the midspan moment in a two hinged frame is impractical.
- B. Glue laminated wood frames are most prevalent.
- C. To simplify erection and transportation, many frames are designed as two distinct parts and then joined to each other and the ground by hinges.
- D. Lateral framing members
 - 1. Can bear directly on top of the frame
 - 2. Can be attached to the frame by metal hangers

Concrete Frames

I. Types And Classifications

- A. Tudor frames--similar to those previously discussed
 - 1. Varies with profile--the column height and the pitch of the arm
 - 2. Varies with the type of supports
- B. Vierendeel trusses--a multi-bay frame in which the columns are joined to the beams both at the top and at the bottom.
 - 1. Varies with the number of columns and panels
 - 2. Varies with the size of columns and panels

(for the vierendeel truss)

II. Structural Behavior

- A. A vierendeel truss behaves like an ordinary truss in the overall structural action.
 - 1. The flanges are either axially stressed in compression or tension.
 - 2. The columns transfer the shear stresses.
- B. If it is uniformly loaded, the individual chords are subjected to bending stresses.
- C. Stress concentrations may occur at the corners and therefore must be adequately braced or stiffened.
- D. Deflection in both the chords and in the overall truss will decrease as the number of intermediate columns increase.

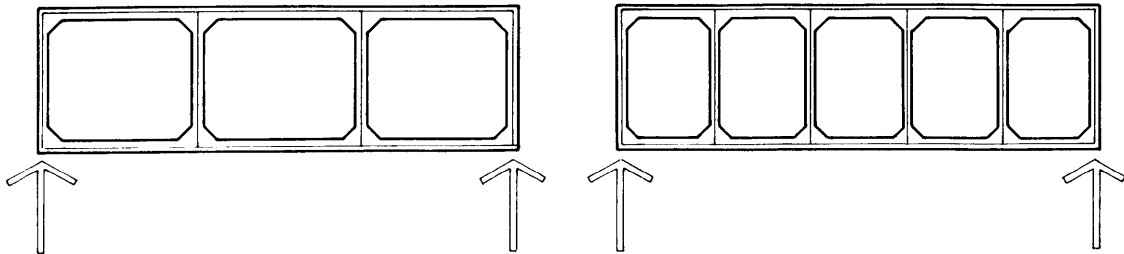

2

E. For uniformly loaded vierendeel trusses, shear increases towards the supports. This action may be resisted in two ways.

1. Reduction of the panel width toward the supports
2. Increase of the column section

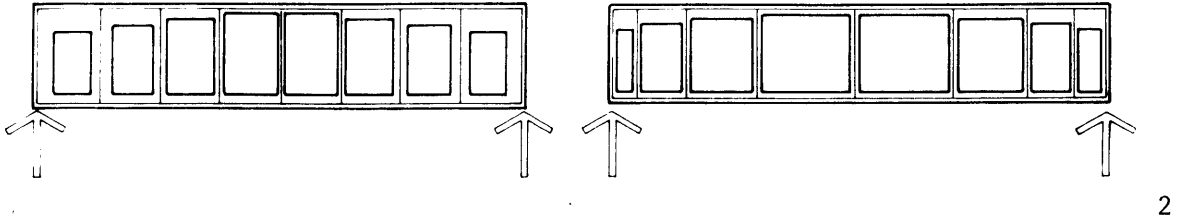

F. These trusses are well suited to long spans while allowing passage through their bays.

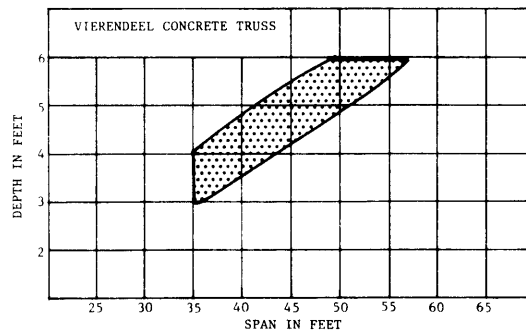
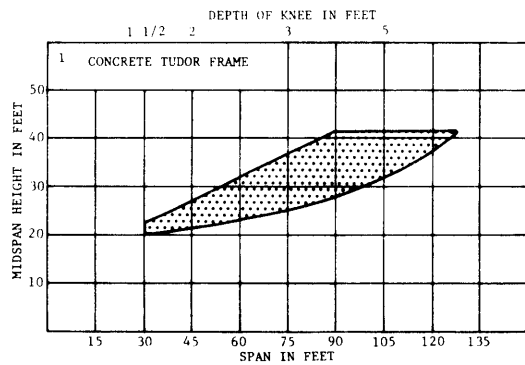
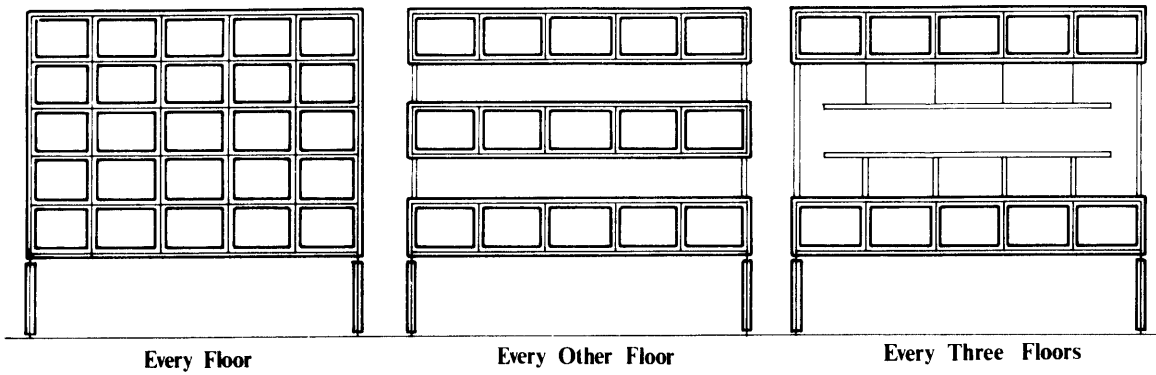

Steel Frames

I. Types And Classifications

- A. The column height and the pitch of the roof arms may be varied.
- B. Either a straight or a haunched knee may be used. Note: Stiffeners are required on radial lines at midpoints and at tangency points.

II. Structural Behavior

- A. Critical aspects in the design of a steel frame include:
 1. The size of the knee--it must have ample section to resist the bending moment
 2. The spacing of the frames--to determine the loading
 3. The degree of pitch--as the frame departs from a rectangular shape, the bending moments, in general, are reduced.

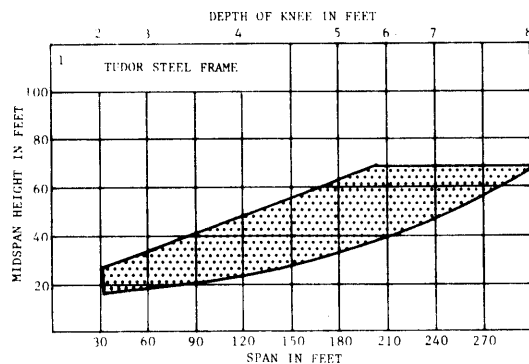

III. Production And Construction

- A. A frame in which uniform sections are employed is less expensive to fabricate than one having variable sections.
- B. Variable section frames are used primarily for long spans.

SIX

Grids, Slabs, And Decking

Theory And Application Of Grids

Definition: A grid is a structural system of intersecting beams having their axes lying in one plane.

I. Types And Classifications

- A. Varies with the number of participating beams
- B. Varies with geometric configuration
- C. Varies with type of supports

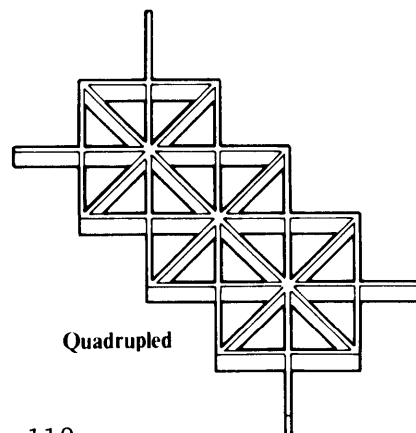
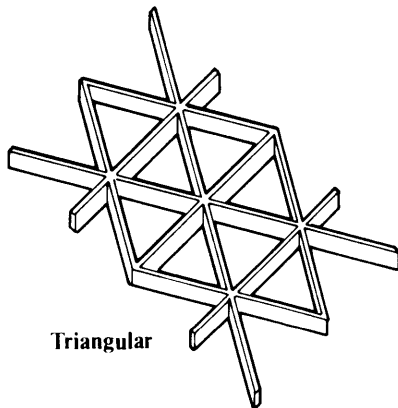
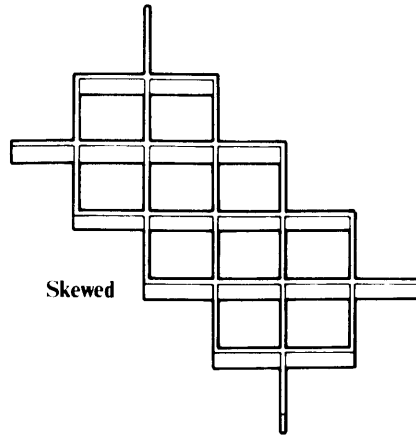
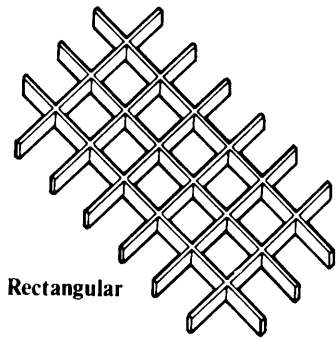

II. Structural Behavior

- A. A grid structure is more efficient than a system composed of separate beams because the interconnected beams share in the load transfer.

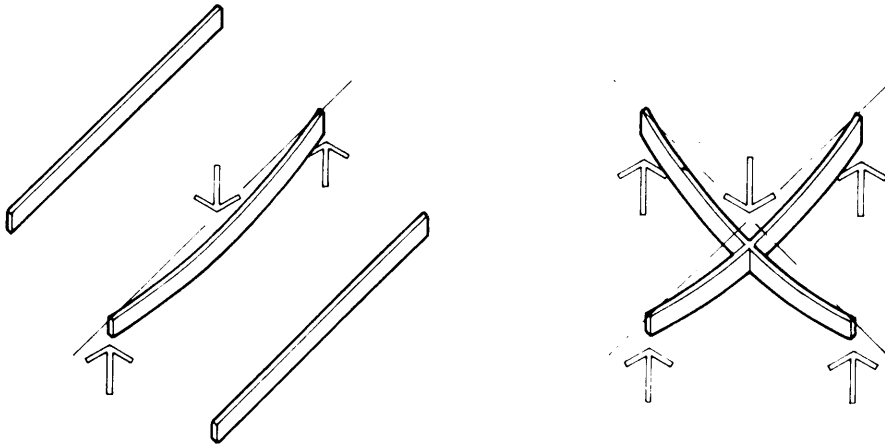

- B. The load on a grid structure is transferred towards all the supports along the longitudinal axes of the beams.
- C. Because the more lightly loaded beams help the more heavily loaded ones in the transference of the load, the structural depth is less in a grid structure than in a system of separate beams.
- D. When the area to be covered becomes rectangular (the ratio between the long side to the short is 2:1 or greater), then a rectangular grid becomes inefficient because the shorter beams carry a greater share of the load. There exists two basic ways in dealing with this problem.
1. Using a skew grid because it is composed of beams of more equal length

2. Using a rectangular grid, but stiffening the long beams in order that their bending resistance be increased

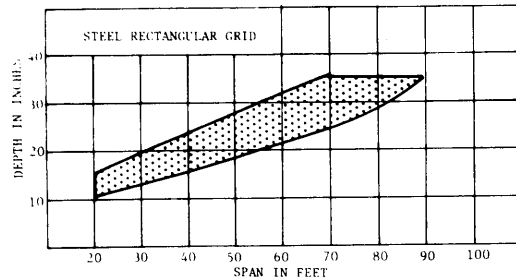

III. Production And Construction

- A. Fabrication of a grid becomes more expensive than a simple beam system due to the numerous connections at the points of intersecting beams.
- B. The beams which compose a grid system are similar in nature to simple beams.
- C. The joints vary with material:
1. Steel--joints can be welded or bolted
 2. Concrete--the beams can be poured in place and therefore the monolithic joints present no difficulty
 3. Wood--joints using standard steel hangers are most prevalent
- D. The more complex the geometric arrangement of the grid, the more complex the joints become because of the number of members and the angles involved.

Theory Of Slabs

Definition: A slab is a reinforced-concrete flat plate, usually horizontal, with top and bottom surfaces parallel or nearly so.

I. Types And Classifications

- A. By the system of supports
- B. Type and magnitude of the load conditions
- C. The size and proportion of the structural bays
- D. The desired construction depth of the system
- E. The location and direction of the reinforcement or stiffeners

II. Structural Behavior

- A. The chief mechanism for resisting loads is bending.
- B. The structural behavior of a concrete slab is usually classified by the number of directions in which a load is transferred to the supports. Most common types include:

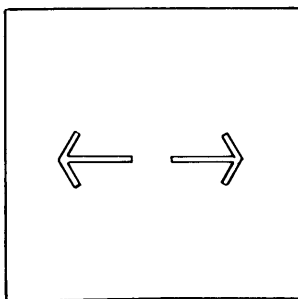

One Way

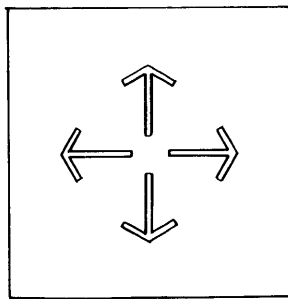

Two Way

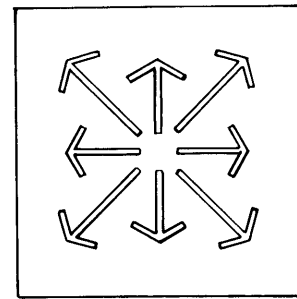

Multidirectional

III. Production And Construction

- A. Concrete slabs are usually poured monolithically.
- B. They are commonly designed for a uniform loading. Large concentrated loads often require additional supporting beams.
- C. Reinforcing steel for slabs is placed primarily parallel to the top and bottom surfaces.
- D. Slabs may be prestressed and/or cantilevered.
- E. Lightweight concrete which may weigh 30 to 50 pounds per cubic foot less than ordinary stone concrete may be used to reduce the structure's dead weight.

Concrete Slabs

One Way Slabs

1. Types And Classifications

- A. Those slabs which are supported on two opposite sides only.
- B. Those slabs which may be supported on all sides but due to the location of the supports the bending moments are much greater in one direction than in the other. When the ratio of the long to short dimension of the slab is greater than two, the slab is said to display one way action and most of the load is transferred in the short direction to the supporting beams.
- C. One way behavior will also result whenever a slab is stiffened more in one direction than in the other. This condition is present when a slab is supported by intermediate beams.

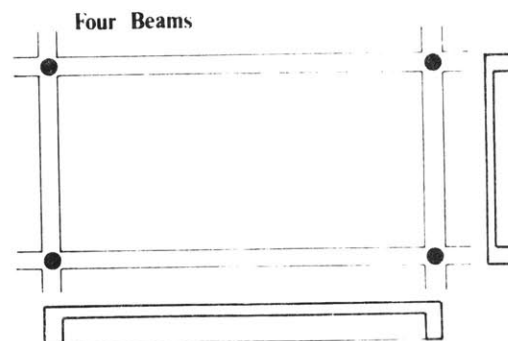
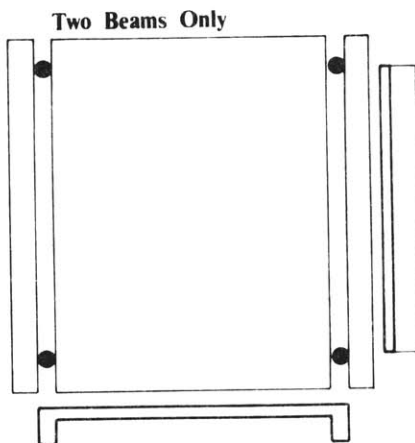

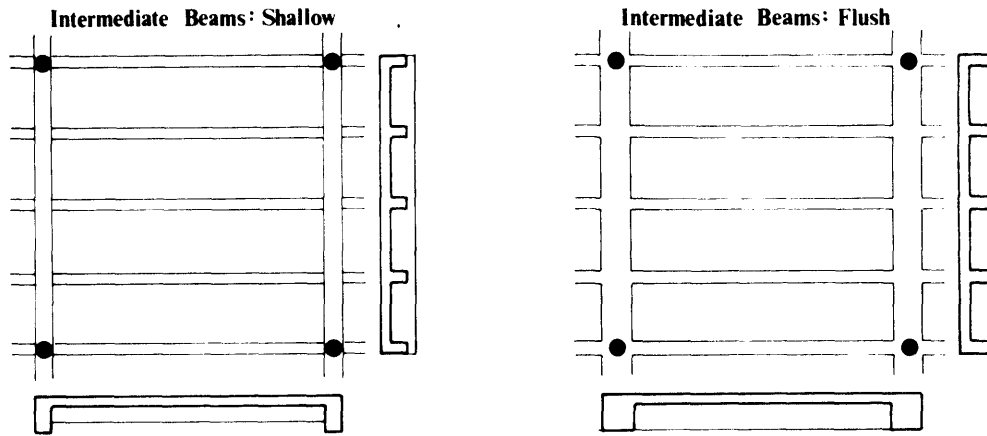

5

II. Structural Behavior

- A. One way slabs resist a given loading by creating bending moments primarily in only one direction and therefore deflect in a single curvature. They are analogous to a series of rectangular beams placed side by side.
- B. One way slabs are used primarily for medium to heavy loadings over short spans.

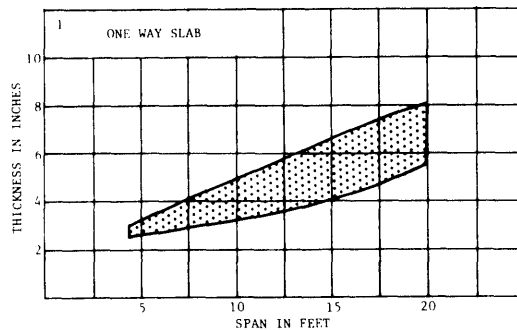

III. Production And Construction

- A. One way slabs which have no intermediate beams offer few problems in construction or analysis.
- B. Minimal temperature and shrinkage reinforcement is placed in the transverse direction.

One Way Ribbed Slabs Or Pan Joist Slabs

I. Types And Classifications

- A. Straight or tapered ribs are possible.
- B. The slabs may have intermediate beams for additional stiffness.

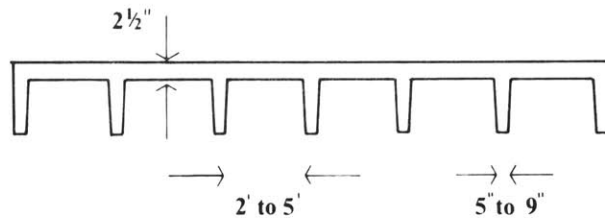
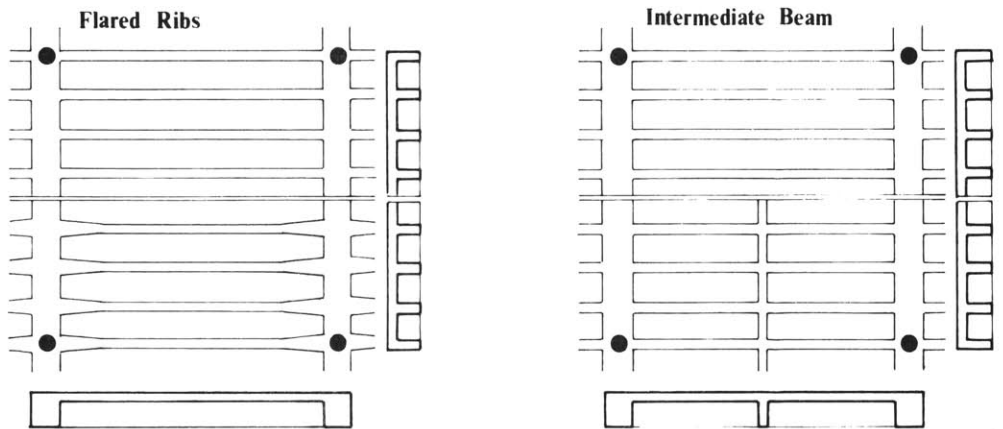

II. Structural Behavior

- A. One way ribbed slabs are used primarily for light to medium loadings over medium spans.
- B. The ribs are flared at the beam supports for greater shear and moment resistance.
- C. The voids between the ribs eliminate concrete that provides little or no moment resistance and permits the system to span farther than the previously discussed solid one way system.
- D. Concentrated loads should be located over ribs.

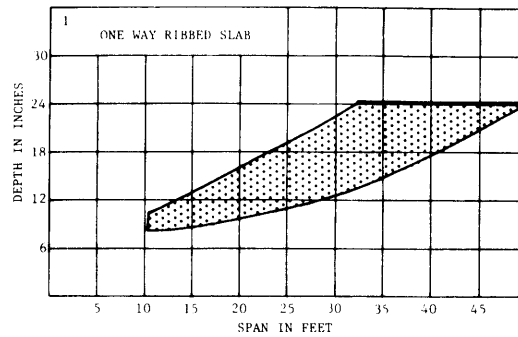

III. Production And Construction

- A. One way ribbed slabs are usually constructed with re-usable metal or plastic forms.
- B. Mechanical systems may be located parallel to the ribs but smaller openings in the joists may be provided to accommodate pipes that run transversely.
- C. Post-tensioning of the system may also be employed.

Two Way Slabs

I. Types And Classifications

- A. Two way behavior will occur in a slab that is supported on all four sides and whose structural bay closely resembles a square. Two way action will also occur if the ratio of the long to the short sides is no larger than 1.7 to 1.
- B. Two way slabs may also have intermediate beams running in both directions in order to increase the stiffness or rigidity of the slab.

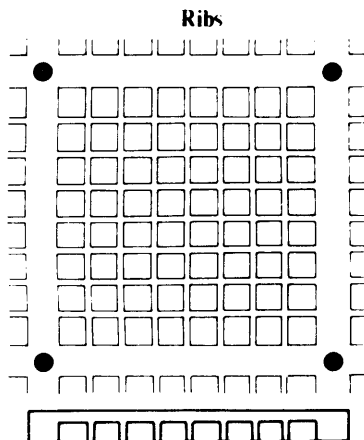
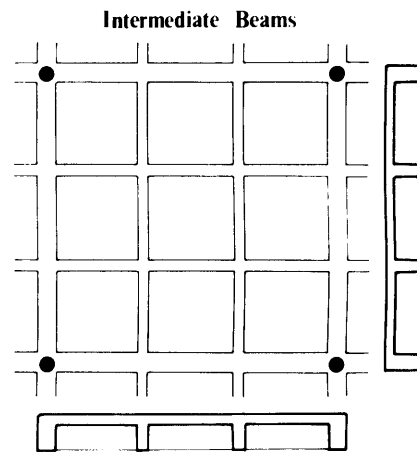
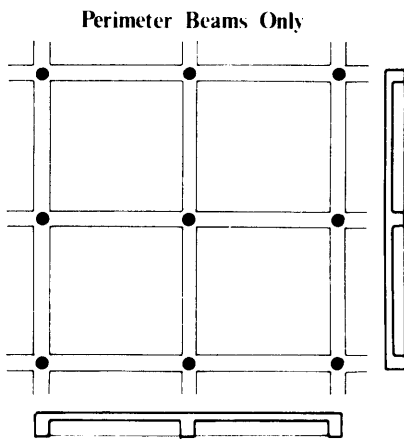

II. Structural Behavior

- A. Two way slabs resist a given load by bending in two directions rather than in only one direction like a solid one way slab or a beam.
- B. At any given point, the slab is curved in both principal directions and bending moments exist in those directions.
- C. To resist these bending moments, the slab must be reinforced by layers of bars which are parallel to the top and bottom surfaces, perpendicular to each other, and perpendicular to the two pair of sides.
- D. Because of the type of supports and reinforcement, a two way slab is best suited for heavy loadings over medium spans.
- E. A rule of thumb for the depth of the slab:
depth = slab perimeter/180 (4" is a minimum)

Flat Plates

I. Types And Classifications

- A. Varies with thickness
- B. Varies with the type of shearhead employed

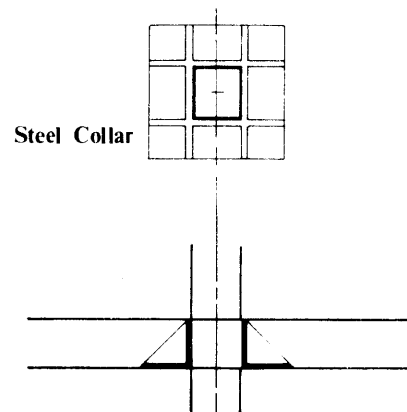
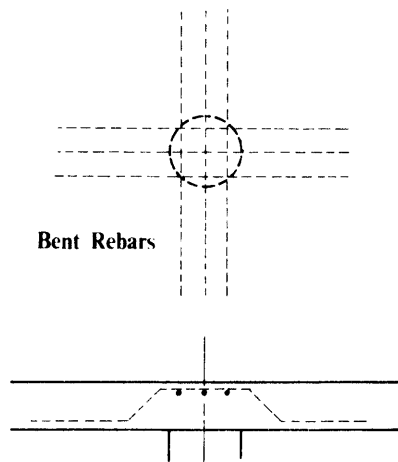
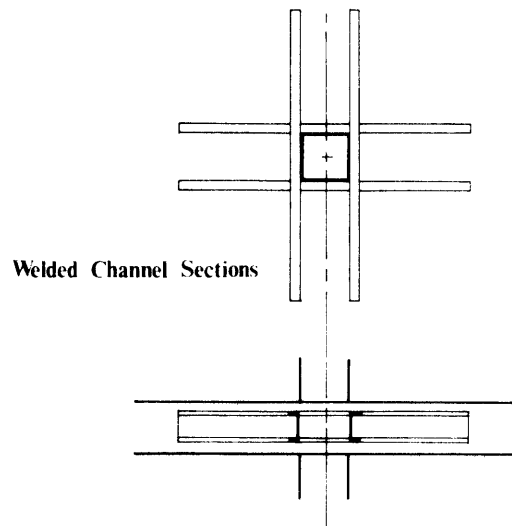
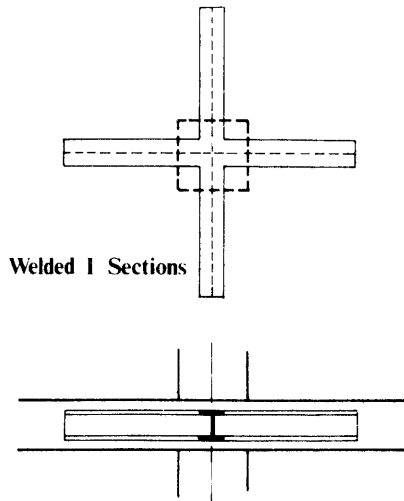
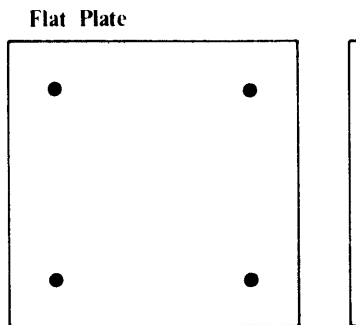

II. Structural Behavior

- A. A load is transferred multi-directionally to the supports.
- B. A concrete flat plate can be cantilevered in order to produce stresses in the plate which are more uniform in magnitude.
- C. Shear at the columns is often the critical factor in design and is controlled by special shearhead reinforcement.
- D. A concrete flat plate is best suited for medium loadings over short spans.

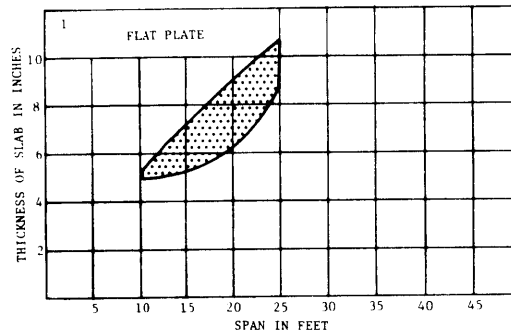

III. Production And Construction

- A. Simple formwork and minimal slab thickness are advantages in a flat plate concrete system.
- B. Column spacing in flat plate construction is flexible--columns need not be in straight orthogonal lines.

Tube Slabs

I. Types And Classifications

- A. The tube slab system is a monolithic one way or two way concrete slab depending on the type of supports and the spacing of the filler tubes.
- B. The filler tubes can vary in diameter and material. Paper and metal tubes are available in diameters from 6" to 18".

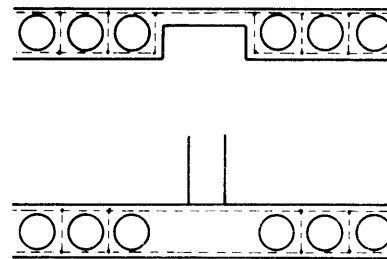
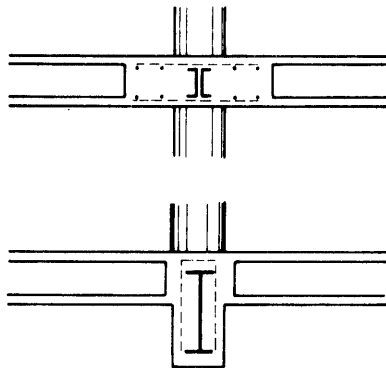
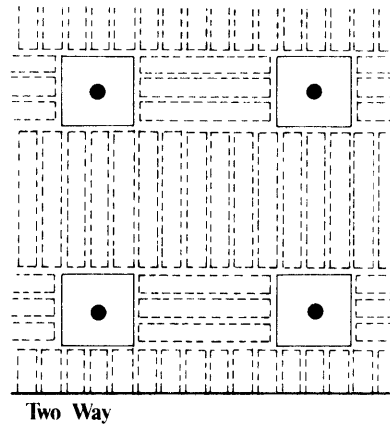
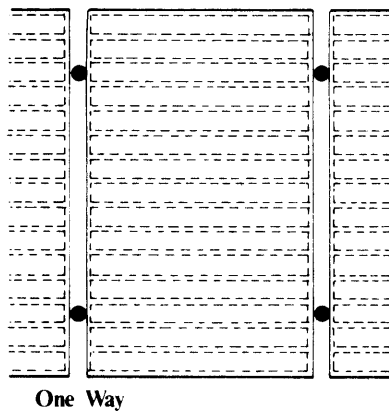

II. Structural Behavior

- A. The thickness of the slab and the tube diameter and spacing vary depending on the span and the loading conditions.

- B. The tubes are placed within a slab near the center, thus eliminating concrete that provides little or no moment resistance.
- C. A tube slab may be post-tensioned to lessen midspan deflections, increase span capacities, and control hairline cracking.
- D. Being a cast in place system, a tube slab exhibits all the advantages of a continuous design.
- E. The slab can accommodate concentrated loads by eliminating the tubes below the load.
- F. The slab may either be supported by steel and concrete beams or by columns with special shearhead reinforcement.

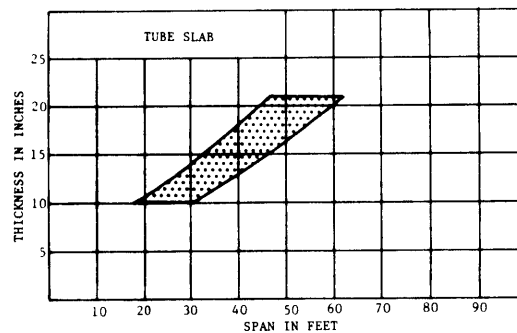

III. Production And Construction

- A. The tubes may be used as electrical raceways or as air ducts.
- B. Column spacing is flexible and cantilevers are possible.

Waffle Slabs

I. Types And Classifications

- A. Varies with type of column/slab connection
- B. Varies with frequency of ribs.

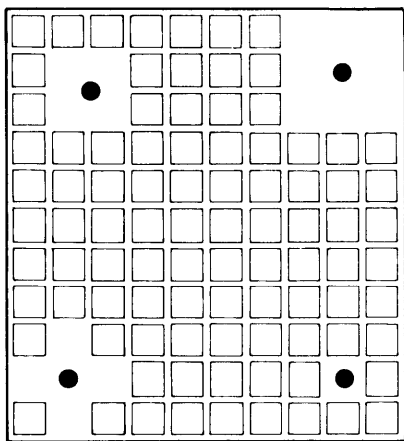

Waffle Slab



5

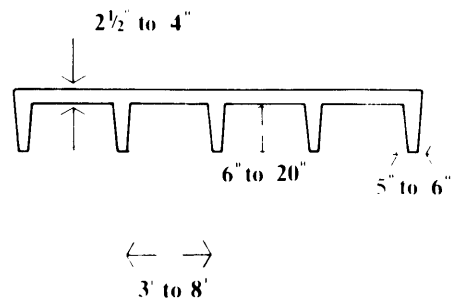

II. Structural Behavior

- A. The length of the span may be increased by post-tensioning in both directions.
- B. A waffle slab is capable of being cantilevered in order to reduce the deflections at midspan.
- C. Coffers around the columns are omitted and additional reinforcement is placed in order to resist the critical moments and shears which occur at the connection.

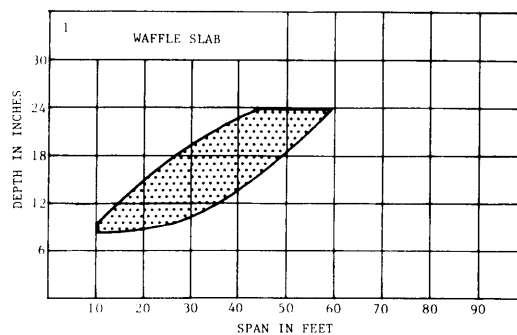

- D. The waffle slab is another example of how the dead load weight of the concrete not used to resist bending moments is eliminated.

III. Production And Construction

- A. A waffle slab is capable of accommodating lighting fixtures and mechanical ducts within the slab depth.
- B. The forms, commonly referred to as domes, vary in size and geometry depending on the manufacturer.
- C. To be economical, the forms must be re-usable.
- D. The ribs of a waffle slab provide a geometry which may be used as an aid in locating partitions.

Flat Slabs

I. Types And Classifications

- A. A flat slab is a multi-directional system supported by columns. The connection between the column and the slab is accomplished with a drop panel or a drop panel and column capital.

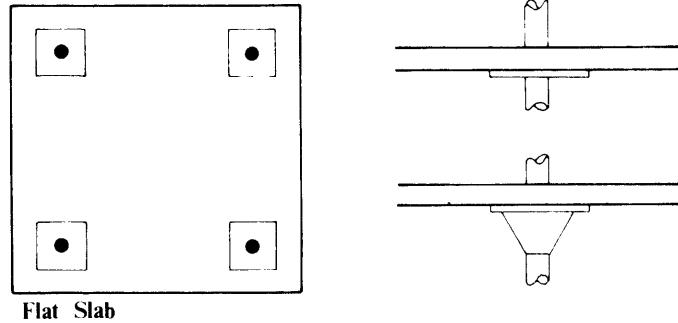

II. Structural Behavior

- A. The two types of connections help to reduce the stresses due to shear and negative bending around the columns.
- B. The size of the drop panels is approximately $1/3$ of the span and $1/4$ to $1/2$ the slab thickness.
- C. The diameter of the column capital (if required for larger shear and bending moments) is equal to 8 or 10 times the slab thickness.
- D. The flat slab is capable of spanning farther and resisting larger loads than a flat plate slab.

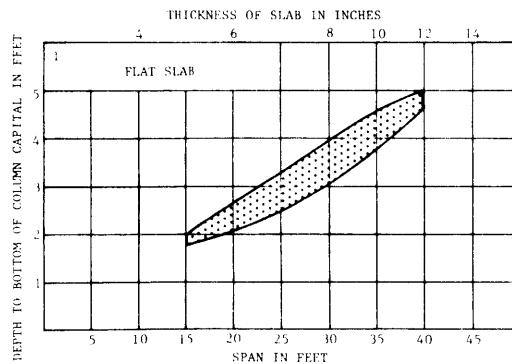

Isostatic Slabs

I. Types And Classifications

- A. Varies with the geometry of the structural bay
- B. Varies with the type and magnitude of loading

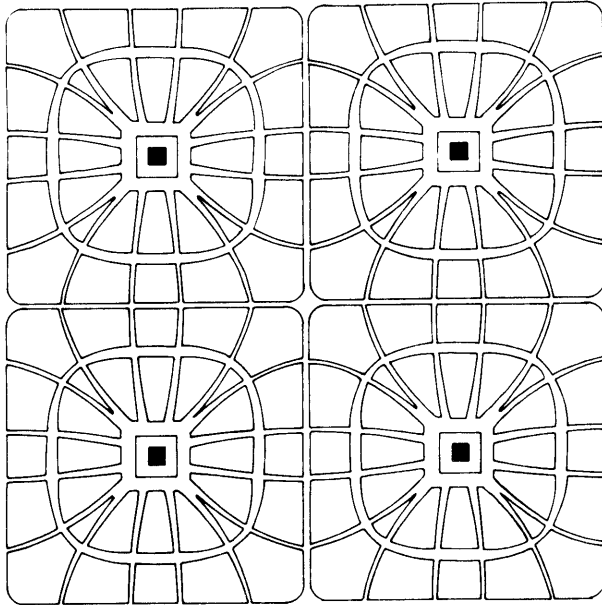

Isostatic Slab

II. Structural Behavior

- A. The ribs follow the principal stress lines of the slab and are perpendicular to each other at their intersections.
- B. An isostatic slab is analogous to a grid system of curved beams.

III. Production And Construction

- A. The curved ribs require expensive forms and are economically possible only if they are re-usable.

Composite Slabs

I. Types And Classifications

A. Varies with components employed

1. Steel beams and a concrete slab

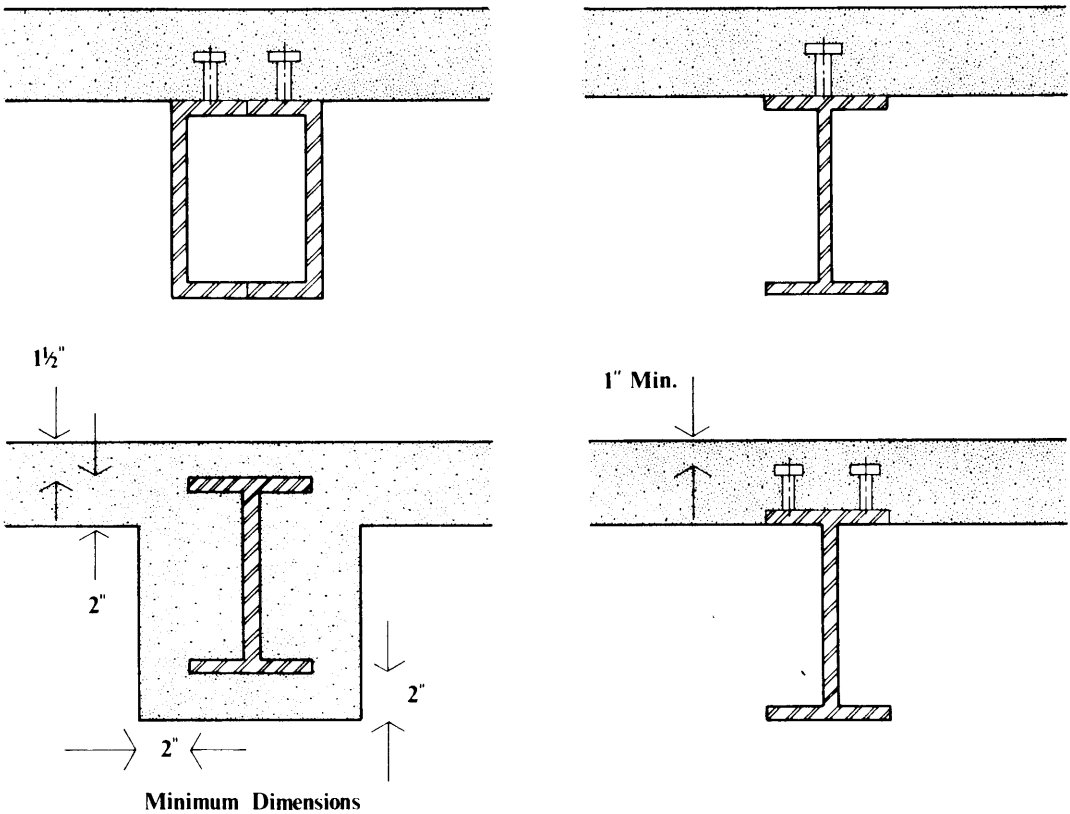

2. Steel beam, steel decking, and concrete topping

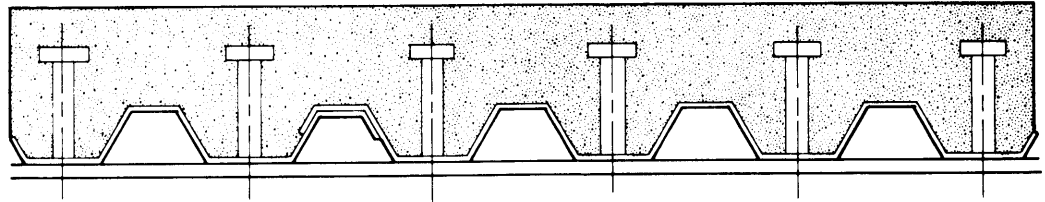

3. Steel beam, precast unit, and concrete topping

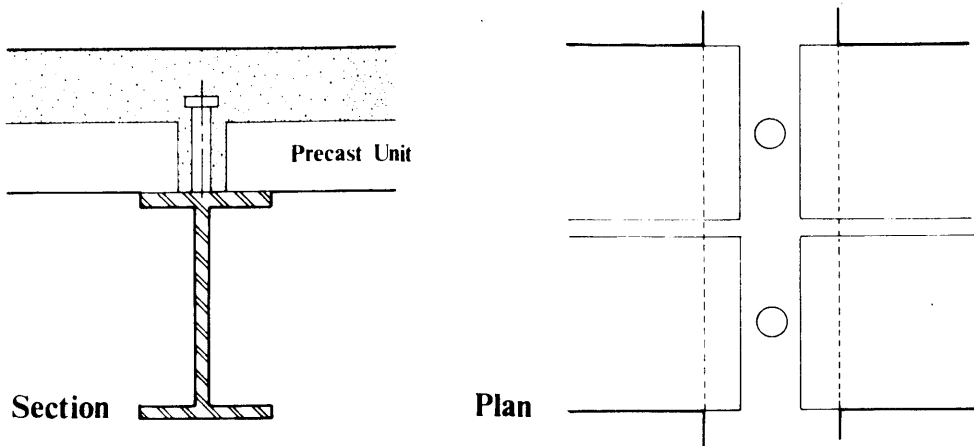

4. Wood beams and concrete slab (see production and construction)

B. Varies with type of shear connector employed

1. Bars
2. Channels
3. Studs (the most common)

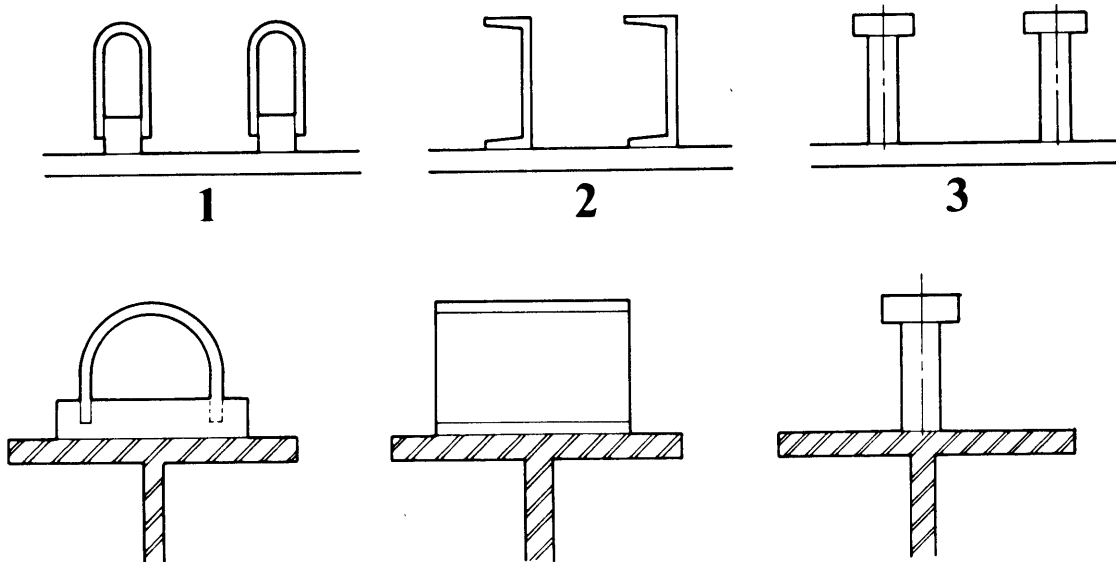

II. Structural Behavior

A. In composite construction, the steel beam and the concrete slab or topping act together in resisting bending. In regular concrete

construction, the concrete topping or slab is the dead load on the steel beams.

B. This type of construction possesses two principal advantages.

1. A given steel beam can be used for a longer span if it is joined compositely with a concrete slab.
2. For a given span a shallower steel beam can be used if it is again joined compositely with a concrete slab.

C. Shear connectors

1. They ensure composite action between the concrete slab and the steel beam by:
 - a. Transferring the horizontal shear between the beam and the slab
 - b. Resisting the tendency for the slab to separate vertically from the beam

III. Production And Construction

A. For general composite construction

1. Caution should be taken in loading a composite steel beam without the concrete slab.
2. Since composite steel beams alone have less load-carrying capacity and resistance to lateral buckling without the presence of the concrete slab, they should be braced during the erection process to avoid overloading.

B. For encased steel beams

1. In order for encased beams to display composite action, shoring of the concrete must remain in place until the concrete attains 75% of its required strength.

2. The encased beam should also be reinforced throughout its depth and across the bottom to prevent spalling of the concrete.

C. Shear connectors

1. Connectors are most economically welded to the top flange of the steel beam in a fabricating shop.
2. Care should be taken in shipping and erecting beams with shear connectors so as not to damage them.

- D. In a wood beam/concrete slab composite, there are four basic steps in the field construction process.

1. Placing the wood beams
2. Installing the concrete formwork
3. Applying the epoxy glue (nails are optional)
4. Pouring the concrete

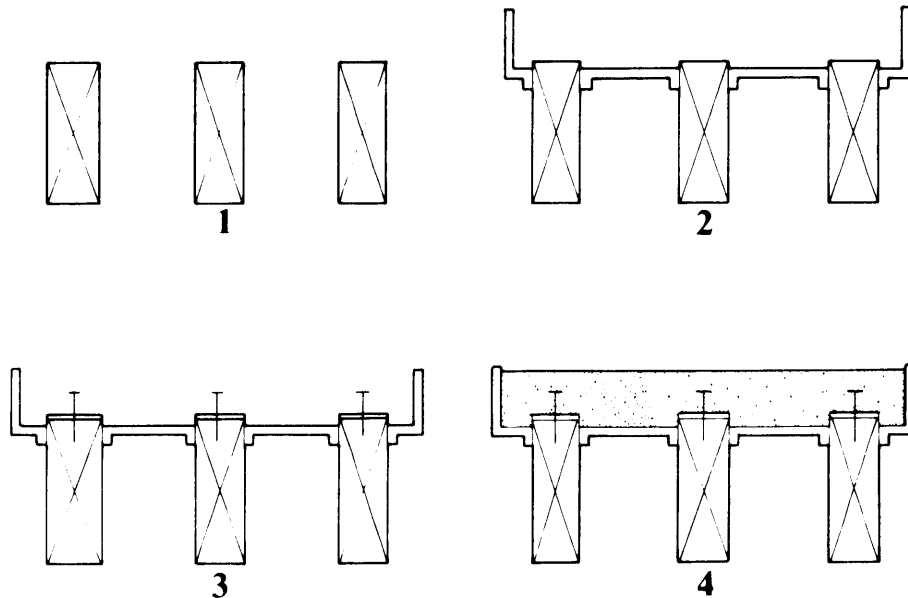

Theory And Application Of Panels, Planks, And Deckings

Definition: Panels, planks, and deckings are structural elements which primarily transfer loads to other structural members (i.e. beams, trusses, channels, joists).

Wood Decking

I. Types And Classifications

A. Varies with cross section--solid or laminated

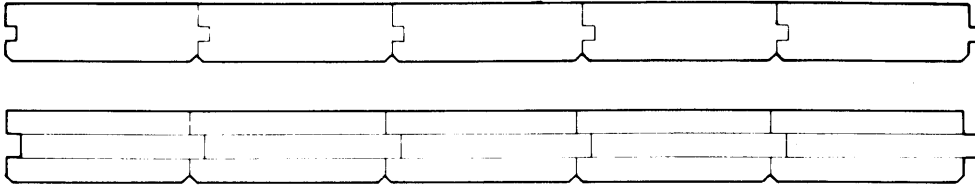

B. Varies with kind of supports--simple or continuous

II. Structural Behavior

A. Simple span

1. The wood planks are simply supported and the critical factor is their deflection.
2. Specific lengths of planks are required.

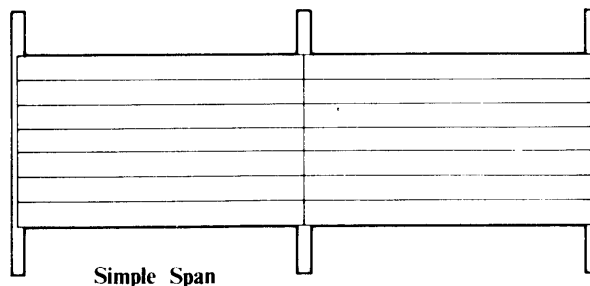

B. Continuous span

1. This is an example of a continuous type of system. The deflections are controlled because the midspan support creates reverse bending in the planks.
2. Specific lengths of planks are required.

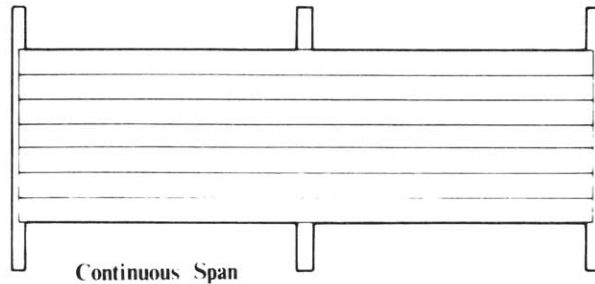

C. Random continuous span

1. This is also an example of a continuous type of system. The end joints should occur at points of minimum bending stresses. Only one end joint should occur in each plank between supports.
2. Random lengths of planks may be used.

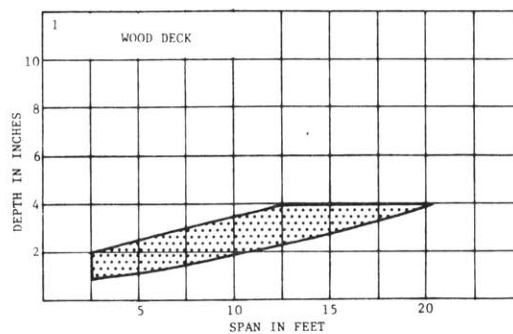
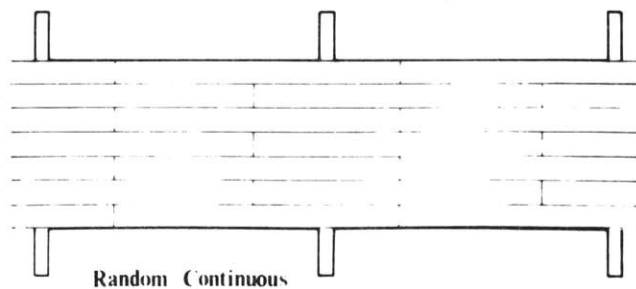

Plywood Stressed Skin Panels

I. Types And Classifications

A. Varies with the dimensions of the components--for home construction:

1. Bottom face--a 4' x 8' sheet of 1/4" 3-ply plywood
2. Top face--a 4' x 8' sheet of 3/8" or 3/4" 5-ply plywood
3. Joists and headers--2 x 6 No. 2 kiln dried southern pine

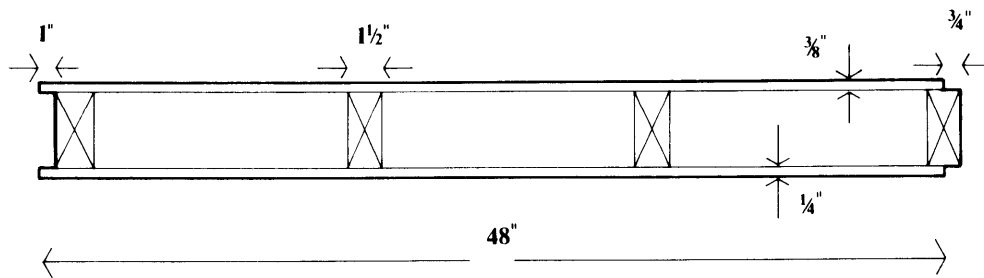

B. Varies with cross-sectional shape--
flat and curved panels
are possible

C. Varies with type of core

1. For flat panels--
structural lumber is
used for the longi-
tudinal framing mem-
bers and headers.

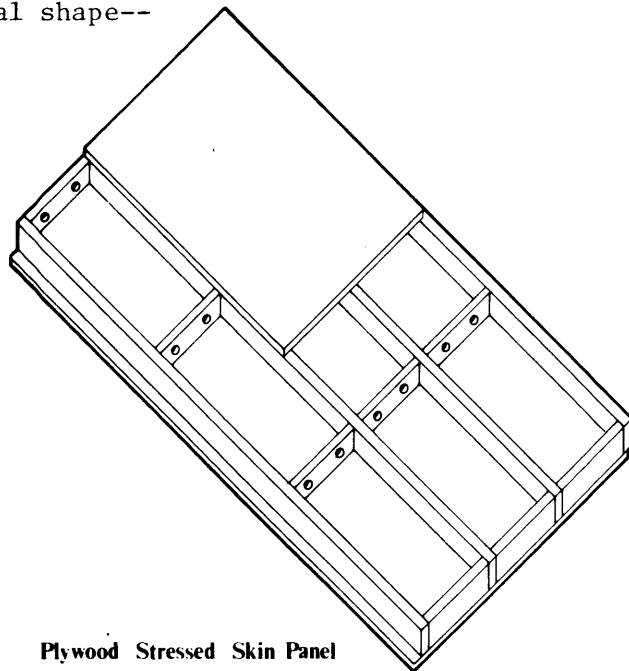

Plywood Stressed Skin Panel

2. For curved panels--

- a. Plywood laminated
ribs (laminated and curved prior to panel assembly)
- b. Resin-impregnated paper honeycomb core

II. Structural Behavior

- A. The action of a flat plywood stressed skin panel is similar to that of a box beam laid flat or of a series of built-up wooden I beams.
- B. If transversely loaded, the top plywood faces are in compression, the bottom faces are in tension, and the lumber stringers resist any shear stresses.
- C. There exists critical tangential stresses between the plywood faces and the joists. In order for the panel to act as one unit, an adequate means of joining the two elements must be achieved.
- D. For curved stressed skin panels--instead of bending stresses, the shape of these elements allows arching action to develop.
- E. Usually the top face of a flat stressed skin panel is thicker than the bottom face because:
1. It must carry the local loads between the joists
 2. To reduce the deflections if used as a floor panel

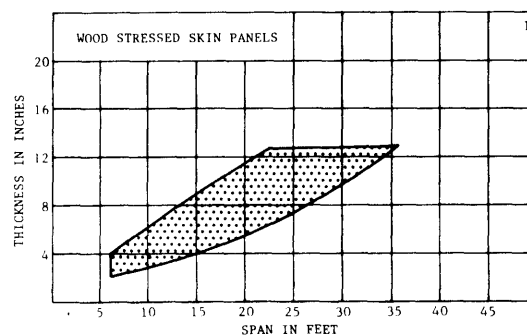
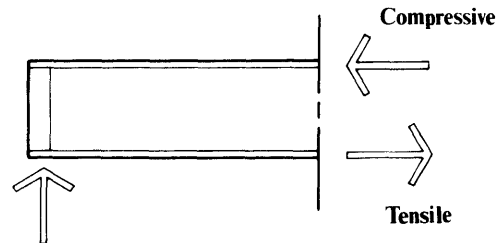

III. Production And Construction

- A. Panels are usually butt jointed end to end and tongue and groove jointed laterally.
- B. Panels may contain insulation, pipes, and wiring.

Concrete Cored Slabs

I. Types And Classifications

A. Varies with manufacturer:

5

TYPE	AVAILABLE WIDTHS	CORRESPONDING DEPTHS
Flexicore	1'-4"	6" and 8"
	1'-8"	10"
	2'-0"	4", 6", 8", 10", and 12"
Spancrete	3'-4"	4", 6", 8", and 10"
	5'-0"	4", 6", 8", and 10"
Span-deck	4'-0"	6", 8", 10", 12", and 16"
	8'-0"	6", 8", 10", 12", and 16"



Flexicore



Spancrete

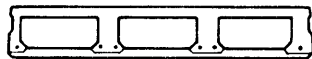
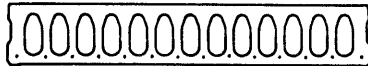

Span-deck



II. Structural Behavior

A. After the cored slabs are set into place, a concrete topping which is typically 2" in thickness is poured. Its purpose is to:

1. Level the cambered top surface
2. Make the cored slabs behave monolithically

B. The allowable stresses of the concrete and steel and the quantity of steel used in the section may be varied to alter the load capacities of the element.

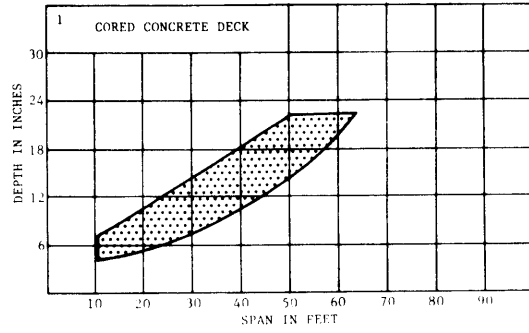

III. Production And Construction

- A. Cored slabs are manufactured by an extrusion process and may be cut into any desired length.
- B. Mechanical distribution and/or pipes and wiring may be located within the hollow cores.
- C. One should contact the local manufacturers of the elements for exact dimensions and availability of particular sections.

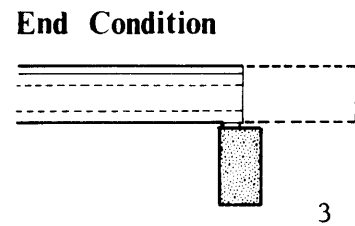
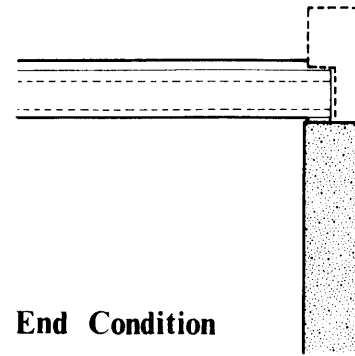
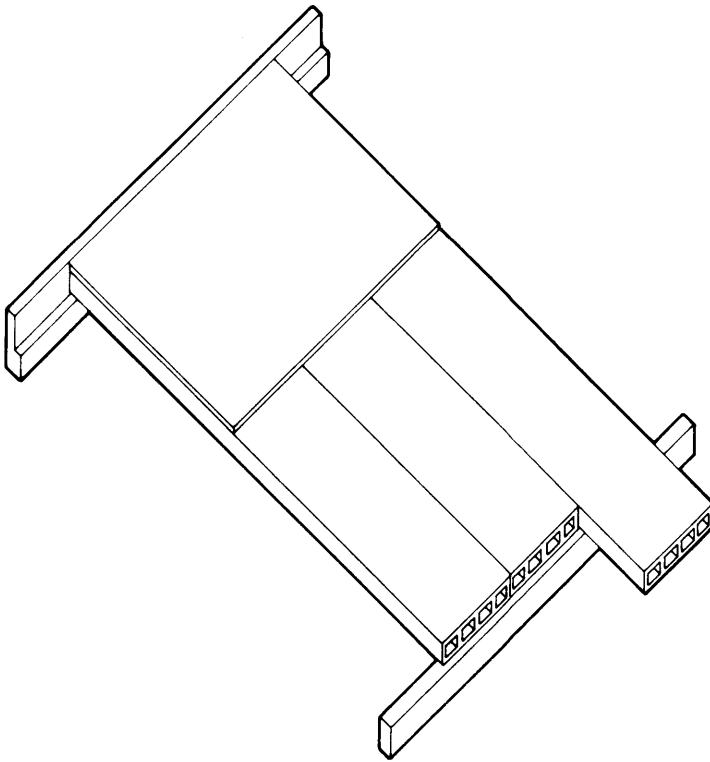

3

Concrete Planks And Channel Slabs

I. Types And Classifications

A. Varies with section and manufacturer:



CONCRETE PLANKS

depth: 1" to 4"
width: 15" to 32"
length: 4' to 10'



CONCRETE CHANNEL SLABS

overall depth: 3 3/4" to 6 3/4"
depth of slab: 1" to 2"
length: 4' to 10'
width: 2' to 4'

II. Structural Behavior

- A. Once again, the relative strengths of the materials and the quantity of reinforcing steel used in the section may be varied to alter the load capacities of the elements.
- B. Cantilevers and continuous designs are possible.

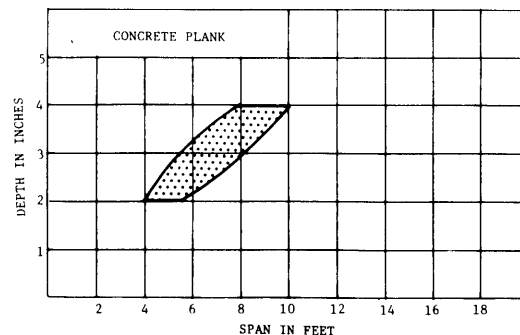

III. Production And Construction

- A. Both elements are almost always precast in fabricating plants under controlled conditions.
- B. One should contact local manufacturer for exact dimensions, finishes, and availability of elements.
- C. These elements are available with a 2 or 3 hour fire rating.
- D. Both elements may be used as wall panels if properly designed.

Application: Concrete Channel Slab System

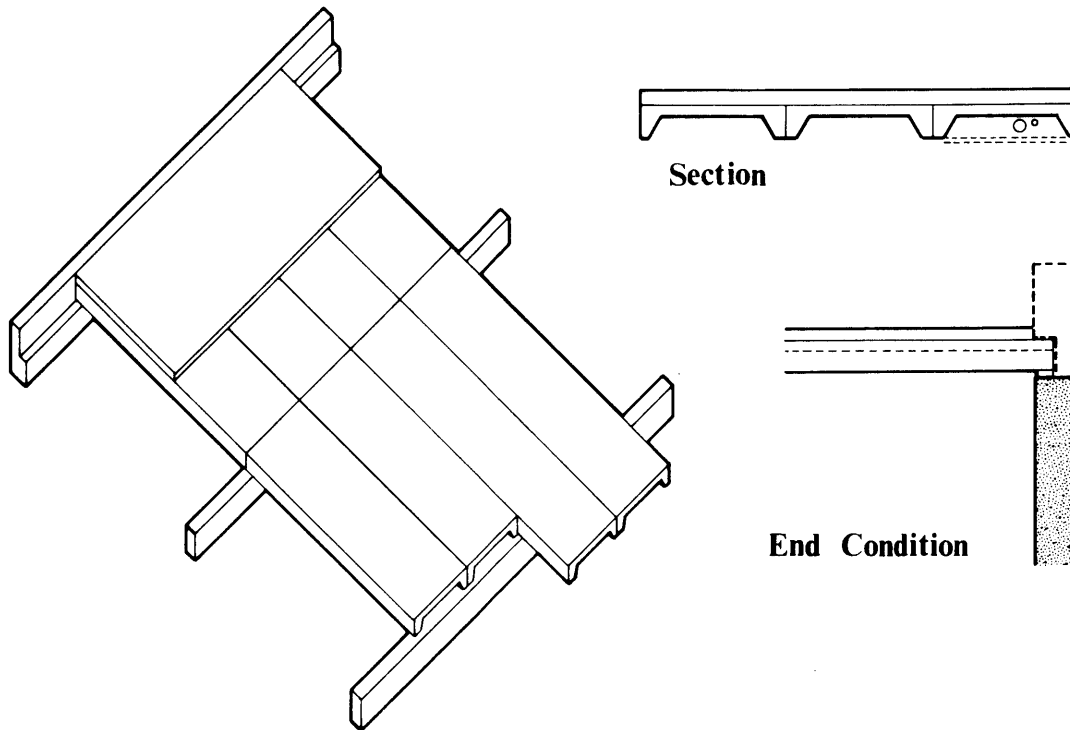

Note: Refer to applications of channels, keystone joists, and tee joists for other examples of usage.

1. The ceiling finish may either be directly applied or suspended from the underside of the elements.
2. A concrete topping (1 1/2" to 2 1/2") is required to level the top surface and to make the planks behave monolithically.

Steel Decking

I. Types And Classifications

A. Varies with cross-sectional dimensions

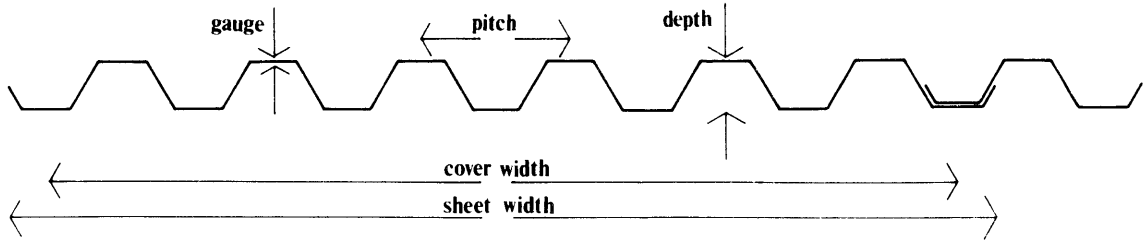

B. Varies in cross section depending on use

1. For roof deckings

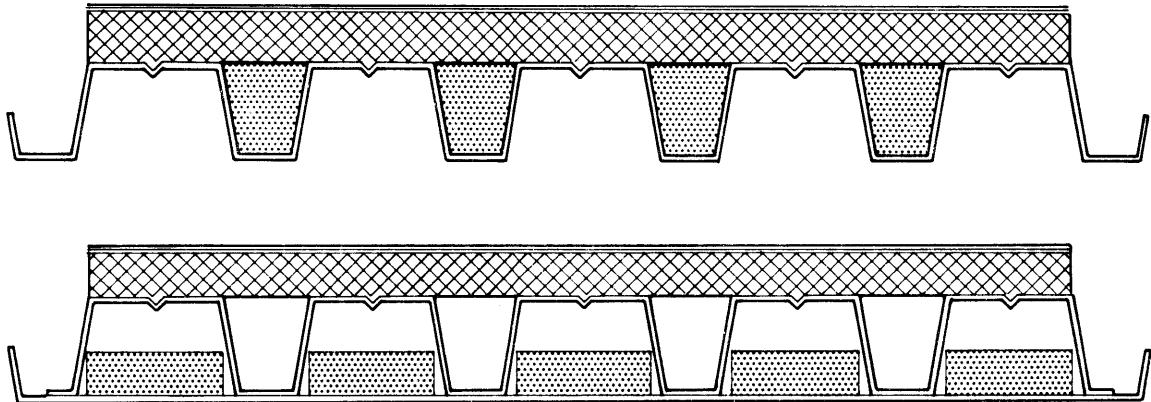

2. For floor deckings

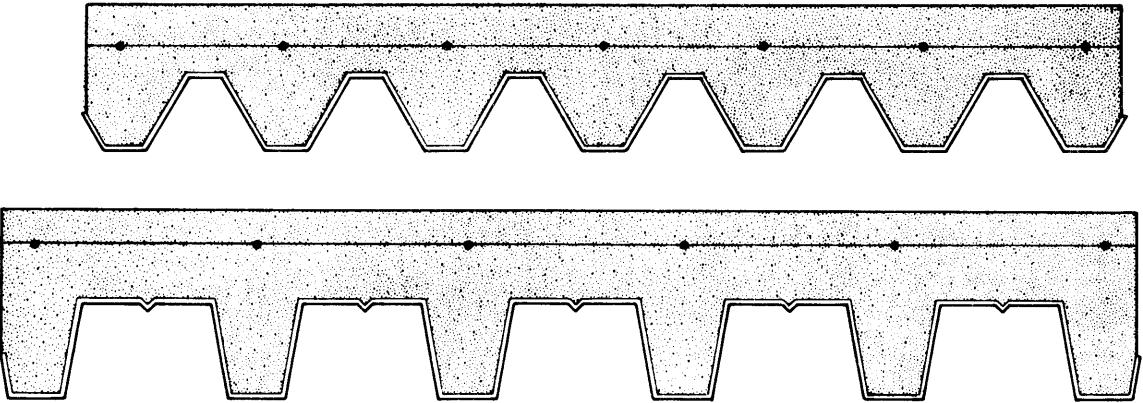

II. Structural Behavior

- A. Manufacturer's catalog provide detailed information on the span and load carrying capacities of the deckings.
- B. For floor systems, the steel decking serves as positive steel reinforcement and as formwork for the concrete slab.
- C. Cantilevers are possible for both types of decking.

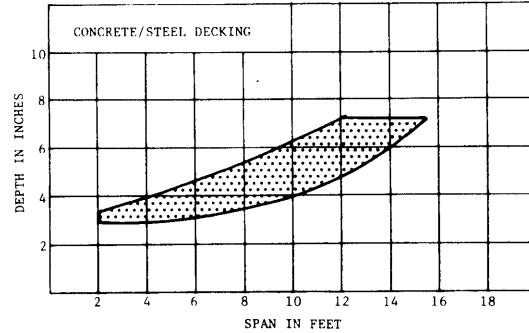
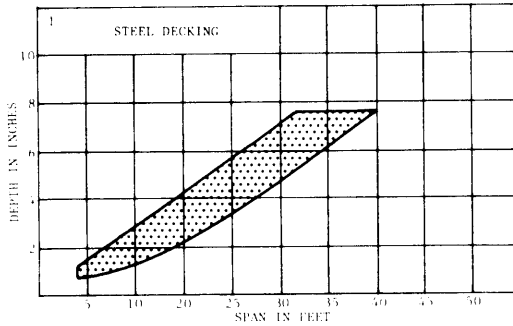

III. Production And Construction

- A. Cellular steel decks are similar in form to the corrugated types except that a steel sheet encloses the bottom.
- B. Cells may be used as utility raceways or to enclose acoustical insulation.
- C. Steel decking is usually galvanized to resist corrosion and spot welded to the supporting structure at least 36" on center.
- D. Wire mesh is used with steel decking/concrete slabs to resist temperature and shrinkage stresses.
- E. Steel decking may be used as a working surface after it is set into place.

Steel Stressed Skin Panels

I. Types And Classifications

- A. Varies with cross-sectional shape--flat, curved, and bowstring panels are available.

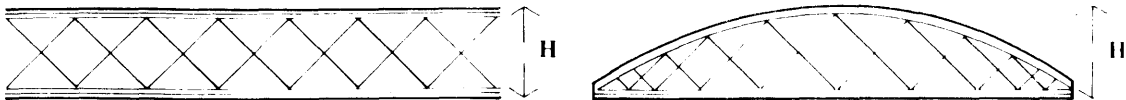

- B. Varies with type of internal bracing--a function of the degree of loading and depth of section.

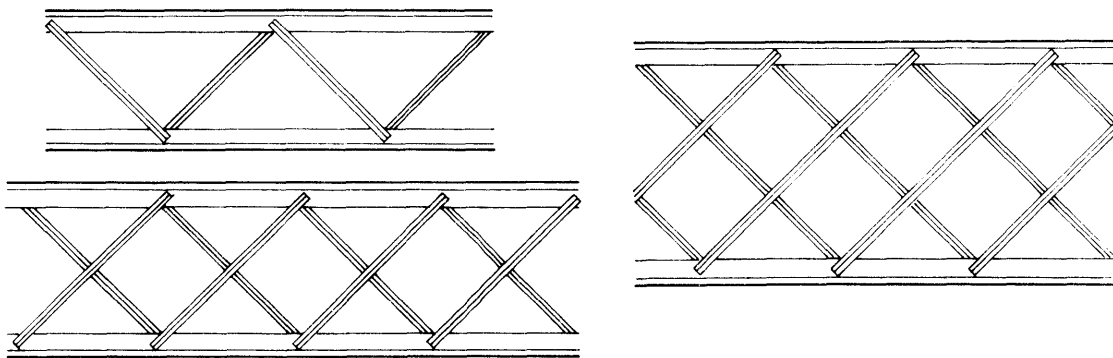

II. Structural Behavior

- A. The action of a flat steel stressed skin panel is similar to that of a flat plywood stressed skin panel. If transversely loaded, the top corrugated steel sheets are in compression, the bottom sheets are in tension, and the internal web system resists shear.
- B. The tangential stresses between the corrugated sheets and the web members is a critical aspect in the design if the components are to act as one unit.

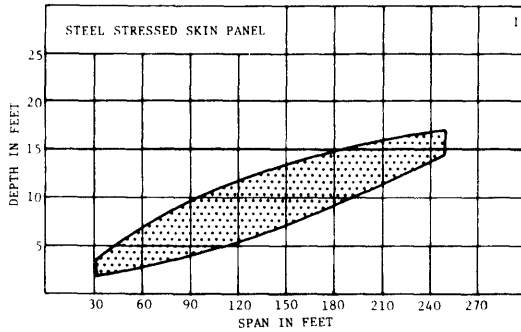

III. Production And Construction

- A. Most panels are fabricated in sections, lifted into place, and then connected.
- B. A typical panel consists of three components.
 1. The top and bottom faces--steel corrugated sheets
 2. The internal web--an arrangement of steel struts
 3. The lateral spacers--steel sections
- C. All joints are either bolted or welded.
- D. The fire rating of the system depends on the applied finish or treatment.

SEVEN

Surface Structures

Theory And Application Of Folded Plates

I. Types And Classifications

A. Varies with cross section

1. The thickness and the depth of the folded plate
2. The geometric form--'w' and 'v' shapes are the most common types
3. The form of the fold lines--sharp or blunted

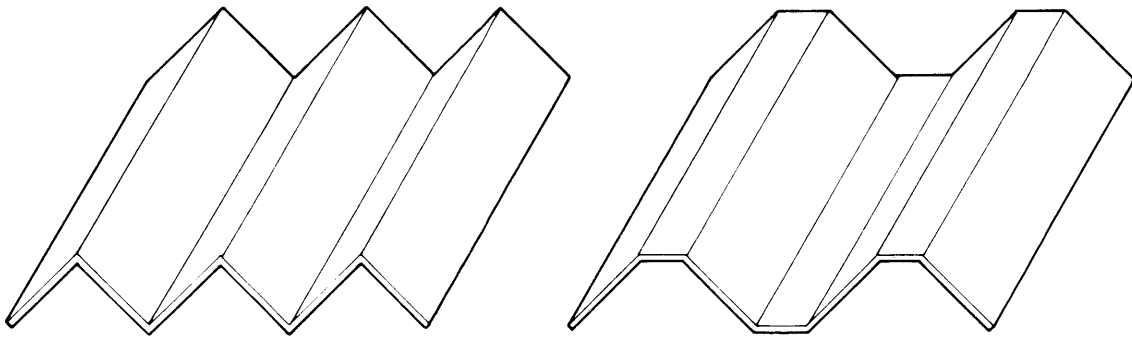

B. Varies with the overall geometry

1. Linear--for rectangular areas
2. Rotational--for circular or polygonal areas

C. Varies with support conditions

II. Structural Behavior

A. The load transfer mechanism

1. Folded plate action is a combination of transverse and longitudinal beam action.
2. Since the ratio of the plate length to its width in most folded plates is large, a load is transferred to the fold lines by beam action in the transverse direction of the plate.

3. The loads are then transferred by longitudinal beam action of the plate to the supports.

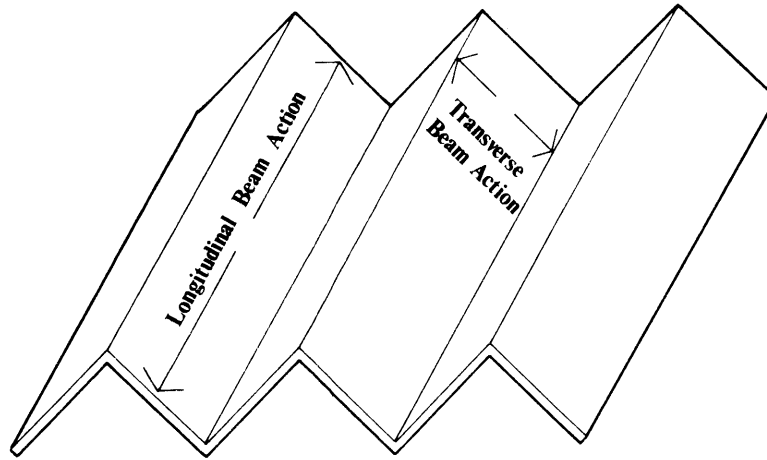

- B. One must prevent instability of the free edge of a folded plate-- the tendency of the free edge of a folded plate to translate normal to its original position.
- C. Stability mechanisms to prevent free edge deformations may be in the form of edge beams that absorb the stresses normal to the plate's plane. The edge beams may be positioned in several ways depending on the degree of folding and the magnitude of the stresses.

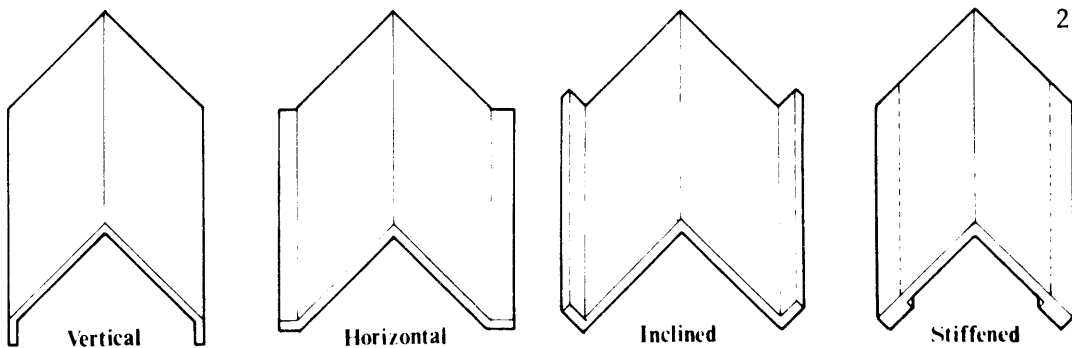

- D. One must also prevent instability of the folded plate in the transverse direction due to a specific type of load.
 1. Dislocation of the lower edges

2. Buckling of both plates
3. Buckling of only one plate
4. Change of the fold angle

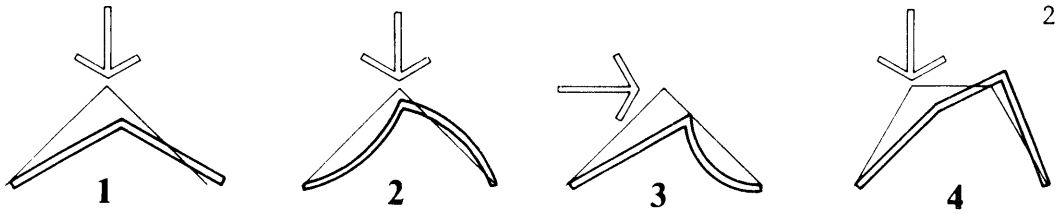

E. Methods to stabilize these conditions include:

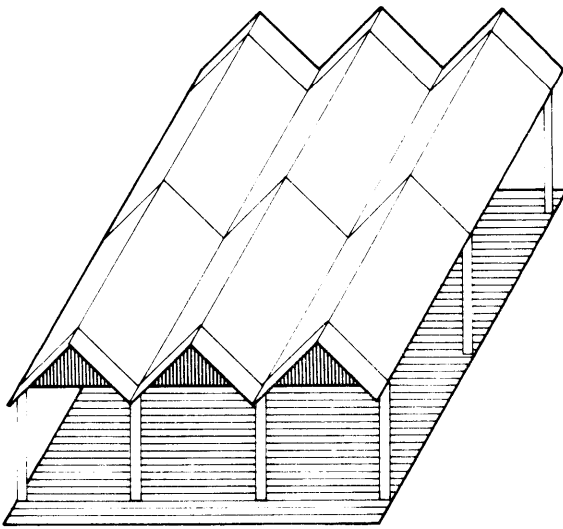

Diaphragm Below Folds

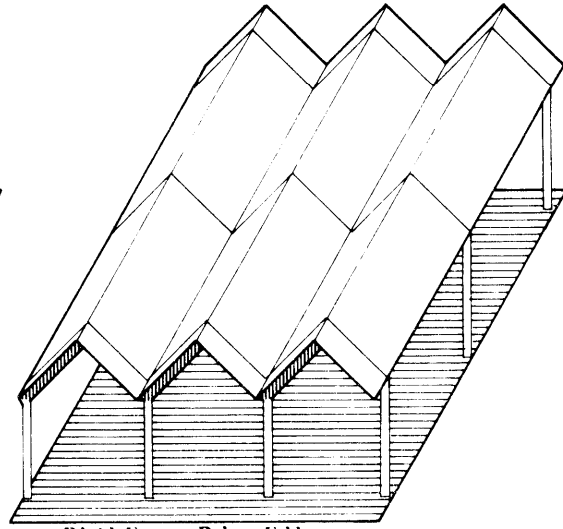

Rigid Frame Below Folds

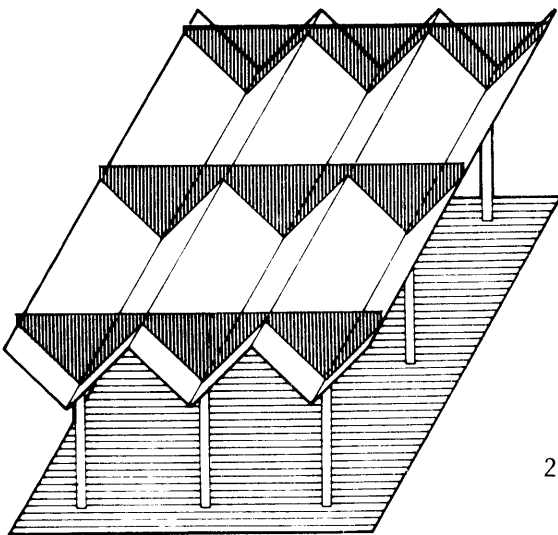

Diaphragm Above Folds

2

III. Production And Construction

- A. Folded plates may be built of wood, concrete, or steel.
 1. Wood--the plates are either stressed skin panels or giant box beams connected by bolts or nails at the folds
 2. Concrete--the plates are commonly concrete slabs welded at the folds
 3. Steel--the plates are commonly stressed skin panels welded or bolted at the folds
- B. Folded plates are usually prefabricated in sections at the site, lifted into place, and then connected.
- C. Cantilevers are possible in all three materials.
- D. Intermediate folds in a plate are possible however, an increase in the number of folds also increases the number of connections and members.

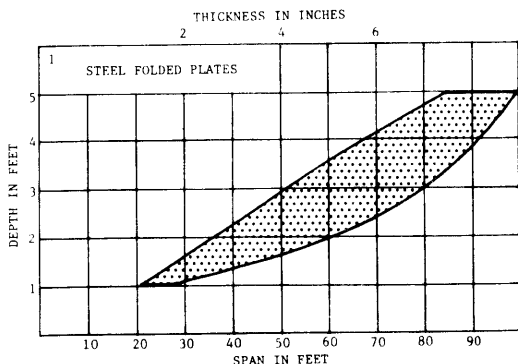
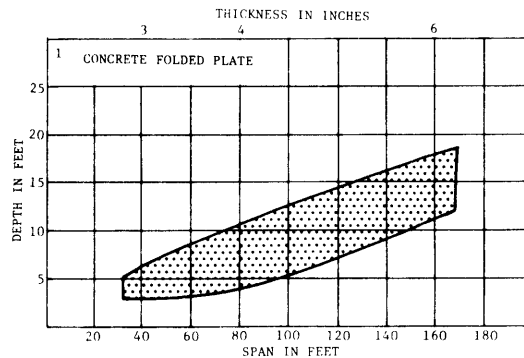
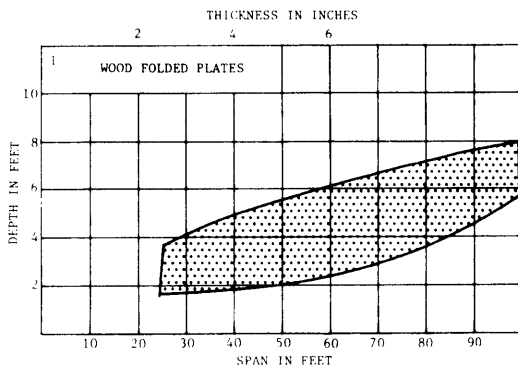

Single Curvature Thin Shells

Definition: Thin shells are structural elements which resist loads by developing membrane stresses of tension, compression, and shear.

I. Types And Classifications

- A. Thin shells with curvature in one direction vary according to support conditions, degree of curvature of the cross section, and the geometric configuration.
- B. Their shapes are developable--they can be made by bending a flat sheet.

II. Structural Behavior

- A. As previously stated, thin shells develop membrane stresses of tension, compression, and shear.

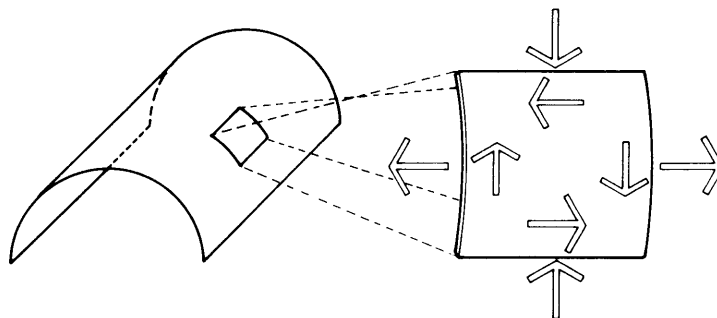

- B. Loads are transferred to the supports by these stresses.
- C. Negligible bending stresses are developed over most of a thin shell's surface.

- D. In order to develop both the membrane stresses and negligible bending stresses, one must select the appropriate support conditions and shell shape.
- E. Transverse stiffeners are required to maintain the shell's cross-sectional shape.

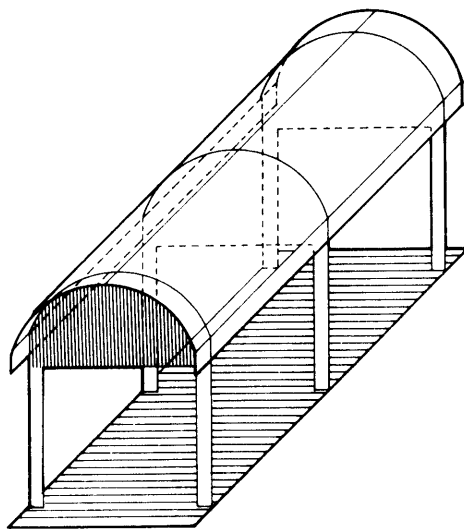

Diaphragm Below Shell

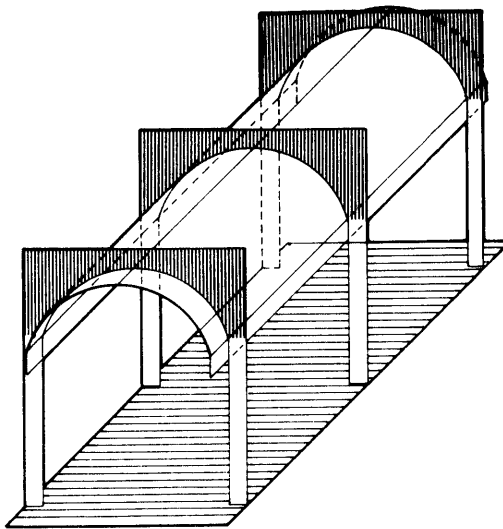

Diaphragm Above Shell

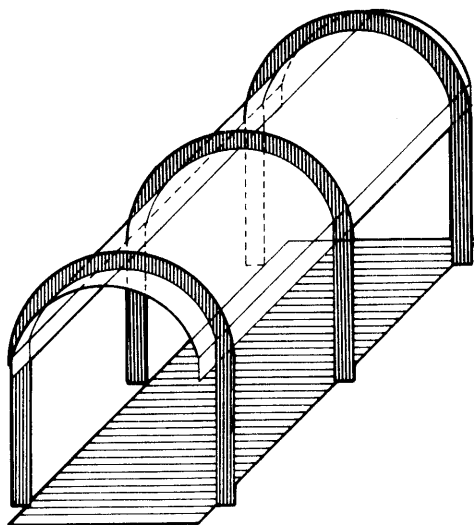

Rigid Frames

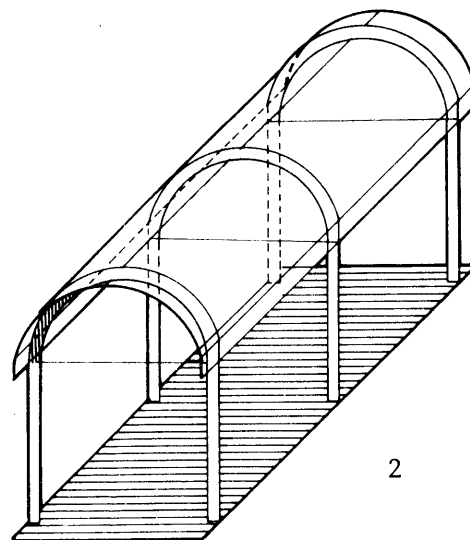

Arch With Cable

2

F. Longitudinal stiffeners are required to resist translation of the lower edge in a direction normal to the plane.

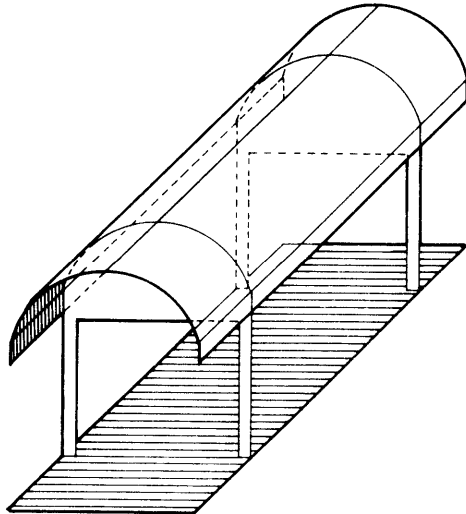

Vertical Edge Beam

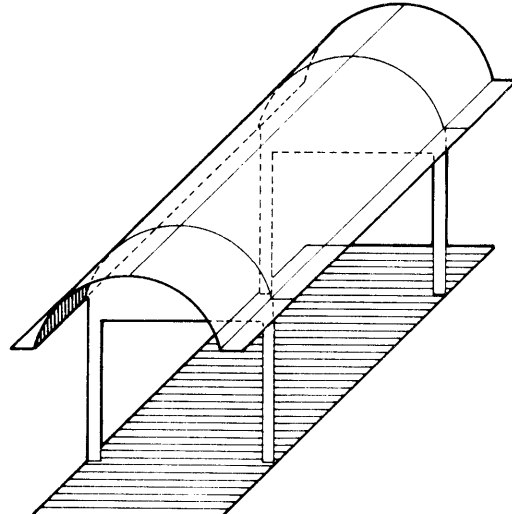

Horizontal Edge Beam

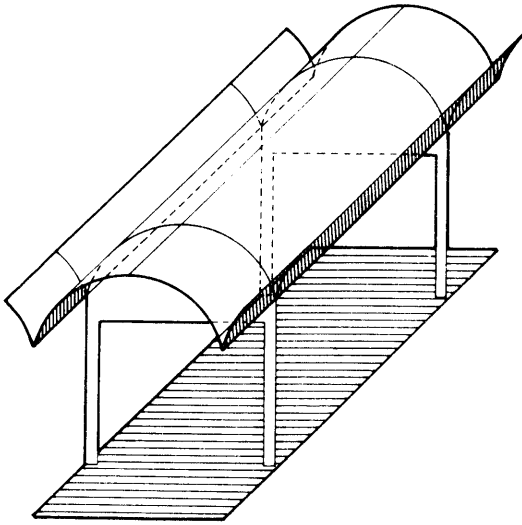

Adjacent Shell Strip

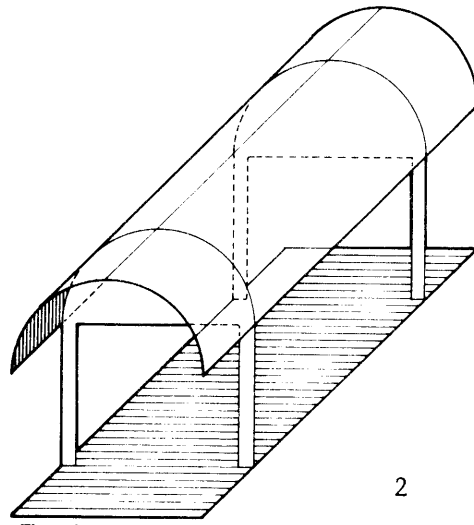

Transitional Curve

2

Long Barrel Shells

I. Types And Classifications

- A. A long barrel shell is one in which the direction of the major span is perpendicular to the curvature.

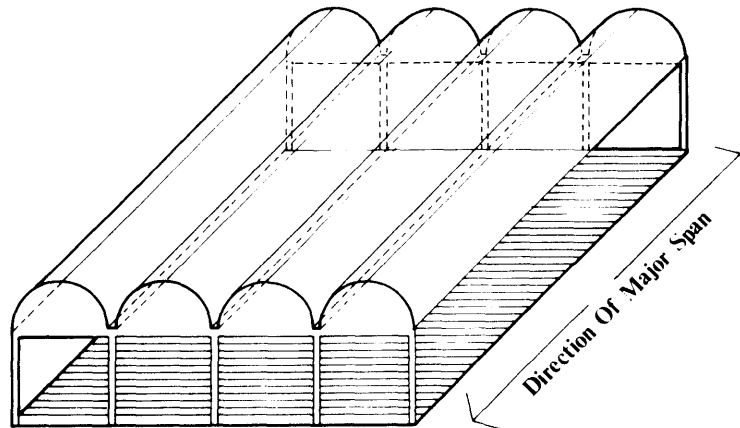

- B. A long barrel shell varies with:
1. Type of support conditions--they may either be supported at the ends or on the sides
 2. Cross section--degree of curvature and thickness of the shell
 3. Geometric configurations--additional units may be placed side by side or end to end

II. Structural Behavior

- A. A long barrel shell displays beam action longitudinally and arch action transversely.
- B. For end supported long barrel shells
1. Beam action--the major load transferring mechanism
 - a. Carries the load to the end frames or stiffeners
 - b. Upper fibers are compressed.
 - c. Lower fibers are in tension.

2. Arch action--the minor load transferring mechanism--is used to receive asymmetric loads.

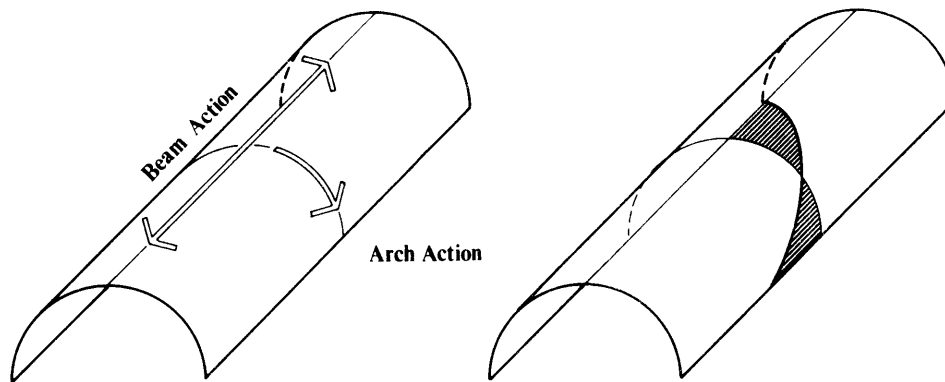

- C. For side supported long barrel shells
 1. Arch action is the major load transferring mechanism.
 2. The shape of the cross section should be responsive to the type of loading. (i.e. If the cross-sectional shape is the funicular curve of the load, only compressive transverse stresses will develop.)

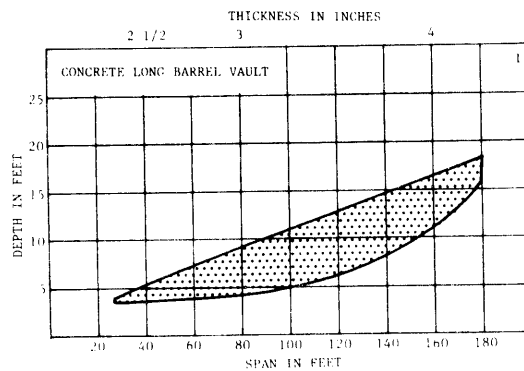

III. Production And Construction

- A. Long barrel shells may be built of wood (prefabricated, curved stressed skin panels), or concrete (precast shell units).
- B. Cantilevers and continuous designs are possible.

Short Barrel Shell

I. Types And Classifications

- A. A short barrel shell is one in which the direction of the major span is parallel to the curvature.

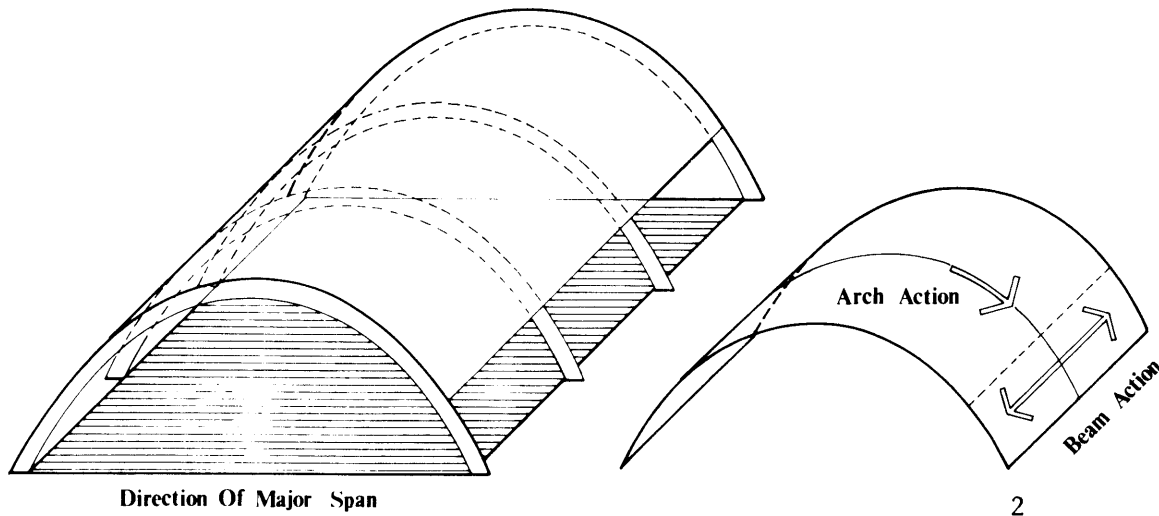

- B. A short barrel shell varies with:
1. Type of support conditions--they may be supported by either transverse arches or continuously on their sides
 2. Geometric configurations--additional units are a continuation of the existing unit

II. Structural Behavior

- A. They behave like a series of arches.
- B. If supported by transverse arches, beam action occurs in a region towards the longitudinal edge and between the stiffeners.
- C. For concrete short barrel shells
1. The transverse arches are usually spaced 20 to 40 feet o.c.
 2. The depth of the crown is $1/50$ to $1/100$ of arch span
- D. Steel short barrel shells consist of single or double layers of latticed members.

North Light Shells

I. Types And Classifications

- A. Varies with cross section

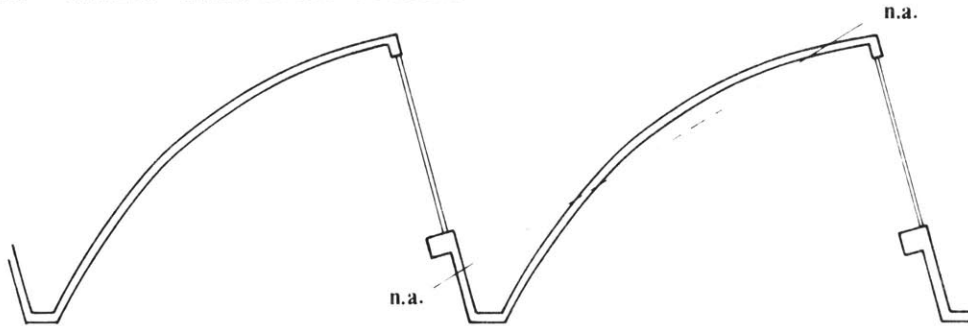

II. Structural Behavior

- A. In general, they behave like a shallow, curved beam.
- B. The neutral axis of the north light shell is inclined. Those areas above the neutral axis are in compression and those below are in tension.

III. Production And Construction

- A. North light shells may be prefabricated elements in either steel or concrete.
- B. They allow for natural light and/or ventilation to enter the space.

Double Curvature Thin Shells

I. Types And Classifications

- A. Their shapes are nondevelopable---they cannot be made by bending a flat sheet.
- B. For synclastic curves
 1. Consists of two perpendicular curves in the same direction.
 2. Loads are transferred by arch mechanisms in both directions.
 3. Example: Elliptical paraboloid
- C. For anticlastic curves
 1. Consists of two perpendicular curves in different directions.
 2. Loads are transferred by arch and cable mechanisms
 3. Example: Hyperbolic paraboloid

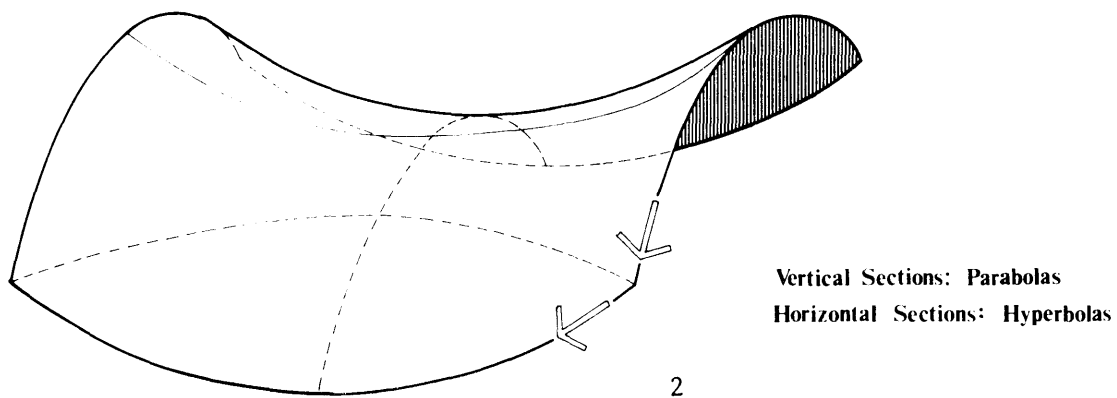
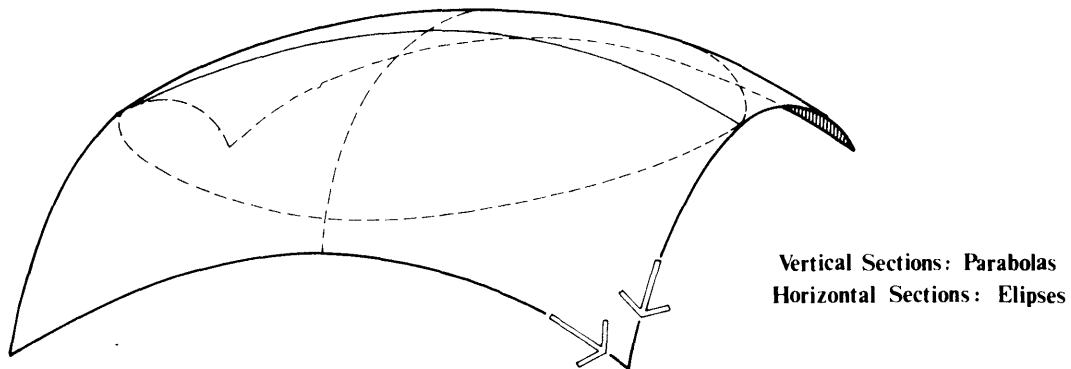

Hyperbolic Paraboloid Shells

I. Types And Classifications

- A. Hyperbolic paraboloid saddle-shaped surfaces
- B. Multi-hyperbolic paraboloid surfaces

II. Structural Behavior

- A. For hyperbolic paraboloid saddles
 - 1. Two structural mechanisms act at right angles to one another.
 - a. An arch mechanism--transfers compressive stresses
 - b. A cable mechanism--transfers tensile stresses
 - 2. The resultant of the stresses caused by the two mechanisms is a single force acting in the axis of the edge beam.
 - 3. The accumulation of the resultant forces acting on the edge beam results in a thrust at the base of the saddle.

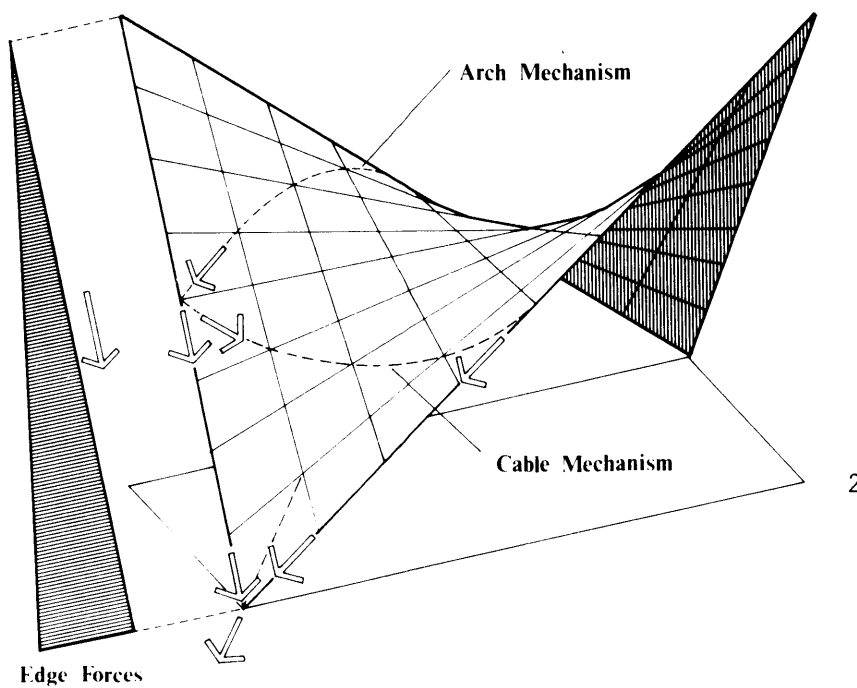

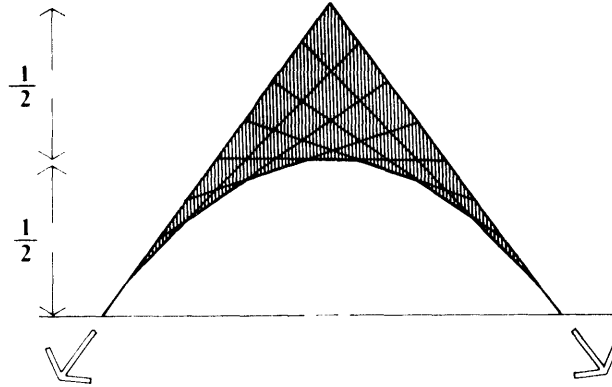

B. For multi-hyperbolic paraboloid surfaces

1. For two supports

- a. The edge beams and the valley folds are in compression.
- b. The ridge folds are in tension.
- c. The horizontal component of the compressive forces at the supports is resisted by a lateral tie.

2. For single supports

- a. The edge beams are in tension.
- b. The valley folds are in compression.
- c. The horizontal components of the compressive forces at the support counteract one another.

3. For four supports

- a. The edge beams and the ridge folds are in compression.
- b. Lateral ties at the supports resist the horizontal components of the compressive forces.

4. For all three types, the forces acting on the folds and edge beams are the resultants of arch and cable action.

C. In hyperbolic paraboloid surfaces, the deflection due to the arch mechanism is counterbalanced by an equal deflection due to the cable mechanism.

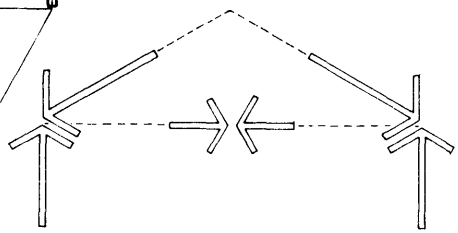
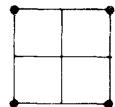
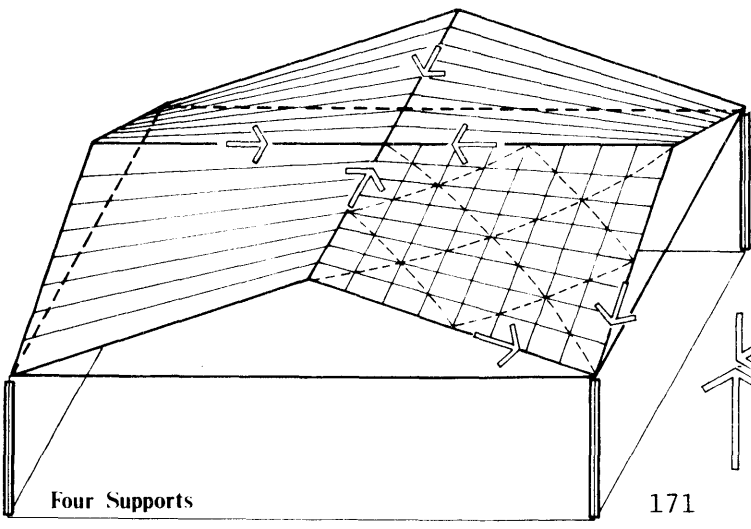
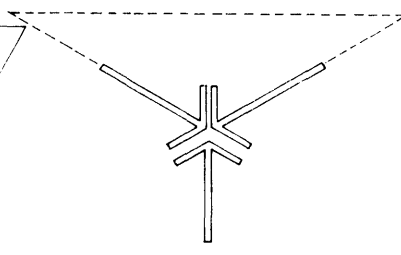
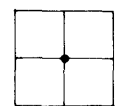
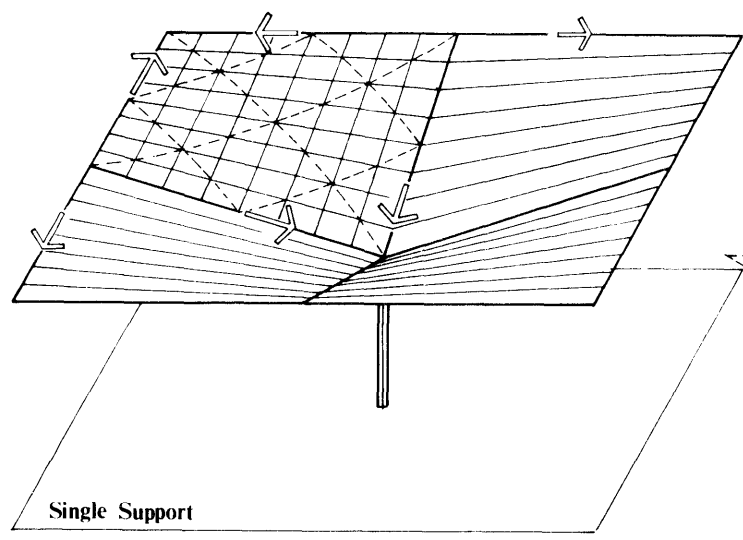
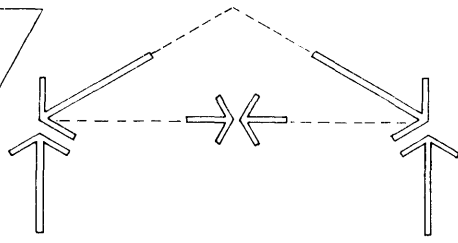
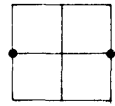
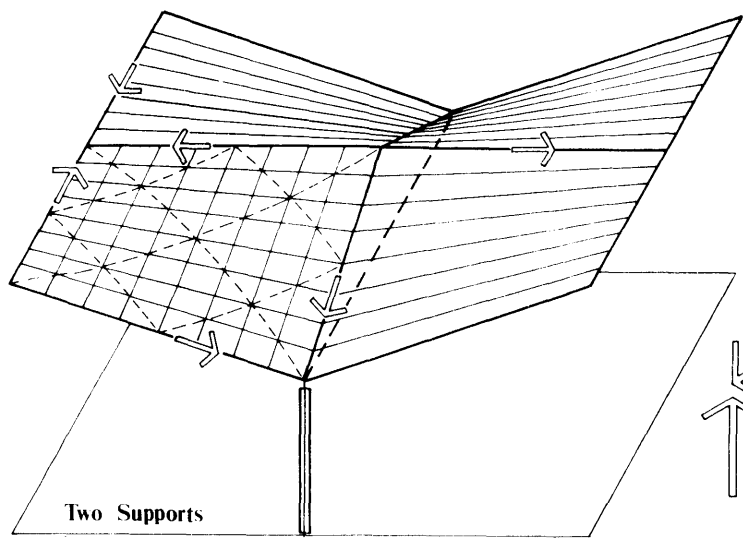

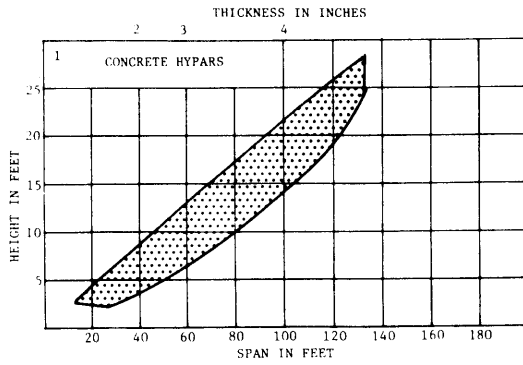
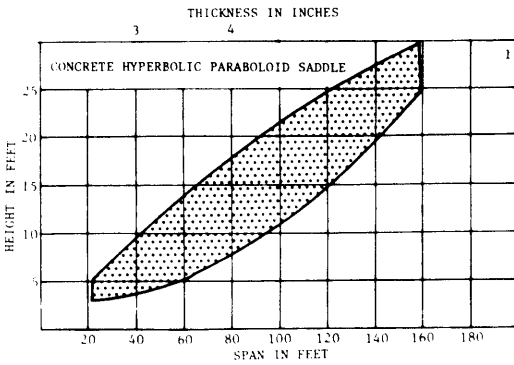

III. Production And Construction

- A. Hyperbolic paraboloid surfaces are generated by straight lines.
- B. For saddle surfaces
 1. The hyperbolic paraboloid saddle must be stabilized against tilting.
 - a. By anchoring the high points with cables
 - b. By buttressing the edge beams with struts
 - c. By rigidly connecting the base to the foundation
 2. The foundation must be able to resist the thrust forces--usually in the form of abutments and a tie beam between supports.
- C. For multi-surfaces
 1. They are economical if the forms are re-usable.
 2. The intersections of the hyperbolic paraboloid units may accommodate roof drainage systems and skylight openings.

Other Double Curved Surfaces

I. Types And Classifications

- A. Doubly curved arch surface--arch action occurs in both directions.
- B. Conoids--a combination of arch and cable action. Side B is a curved line. Side A is either a straight line or a curve of different radius.

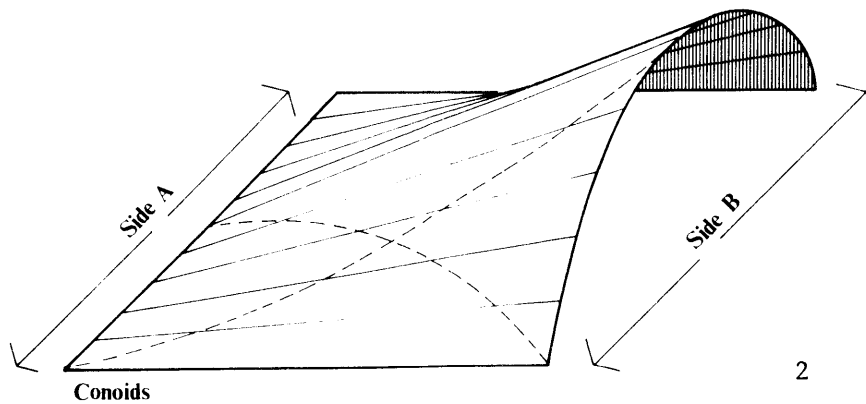
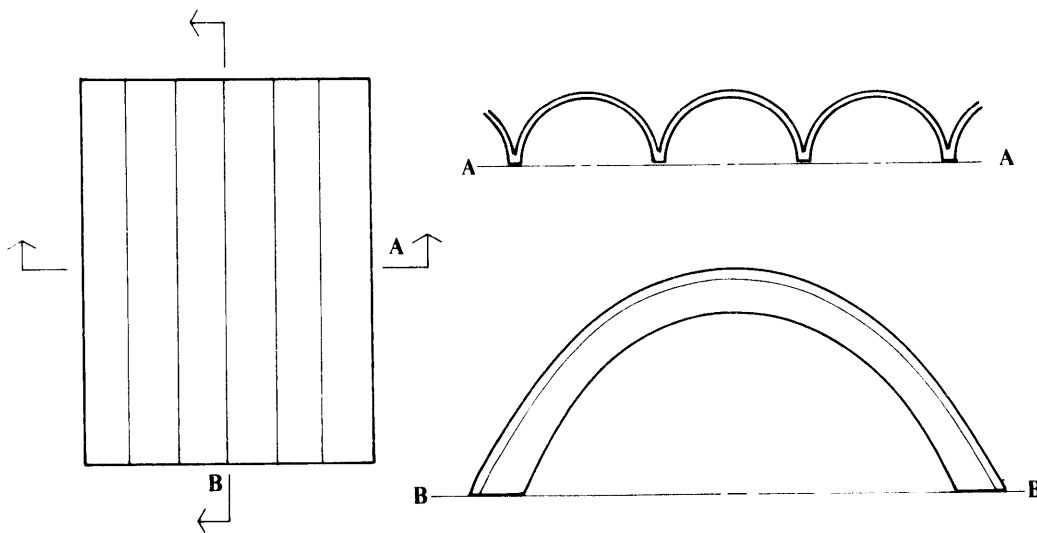

Geodesic Domes

I. Types And Classifications

A. Varies with the number of subdivisions

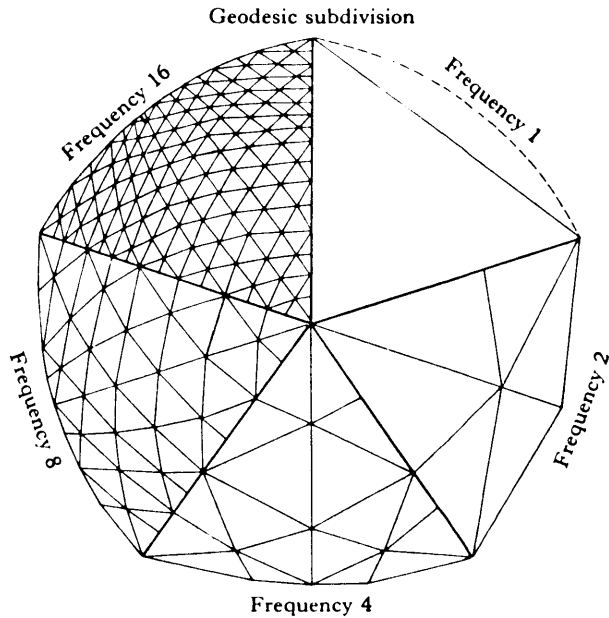

II. Structural Behavior

- A. A triangular subdivision of the surface is the most stable.
- B. Forces are transferred axially along the members. For exact values of these forces, special computer programs are available.

III. Production And Construction

- A. Geodesic domes are the most efficient enclosure system since they contain the greatest volume per unit area of surface.

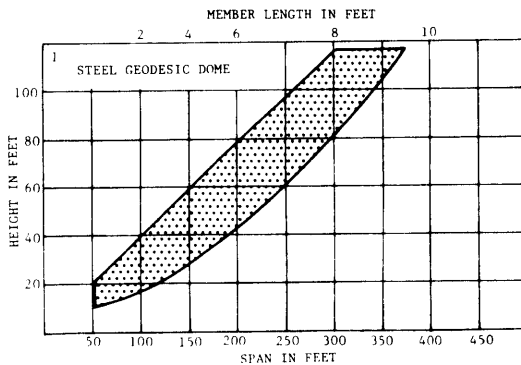

EIGHT

Columns And Walls

Theory Of Columns

Definition: Columns are linear structural elements which are vertical and subjected primarily to compressive stresses.

Note: An inclined element primarily subjected to compressive stresses is referred to as a strut.

I. Types And Classifications

A. Classified according to type of support

1. Pinned at both end
2. Fixed at both ends
3. Pinned at one end and fixed at the other
4. Fixed only at one end

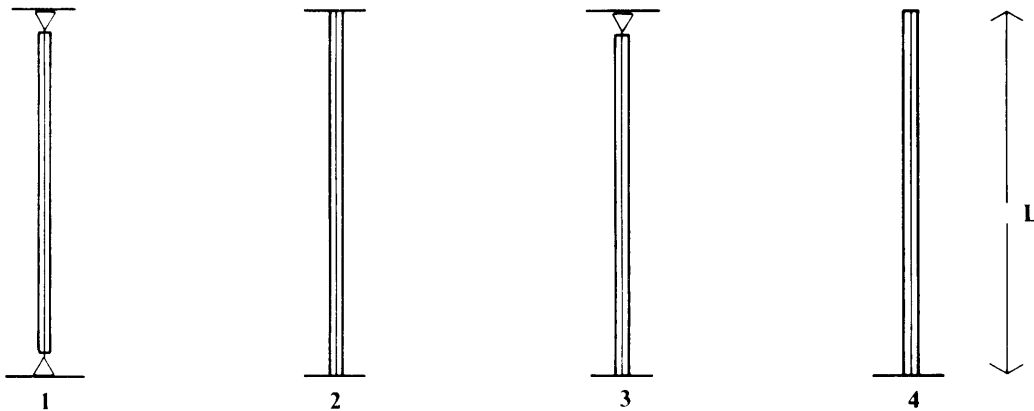

B. Classified according to type of applied load

1. Axially loaded
2. Eccentrically loaded
3. Laterally loaded

II. Structural Behavior

A. For axially loaded columns

1. $f_c = C/A$ where f_c = the actual compressive stress

C = the axial compressive force

A = the cross-sectional area

2. $A_{\min} = C/F_c$ where F_c = the allowable compressive stress

A_{\min} = the minimum area needed to carry the force

3. $\epsilon_c = f_c/E_c$ where ϵ_c = the compressive strain

E_c = the compressive elastic modulus

4. $\Delta L = -\epsilon_c L$ where ΔL = the change in length

L = the original length

5. $\Delta d = v\epsilon_c d$ where Δd = the change in the lateral dimension

d = the original lateral dimension

v = Poisson's ratio

B. A column's load bearing capacity is directly related to the cross-sectional area and the unsupported height.

C. A column will bend out of its plane or buckle when the compressive load reaches a specific value referred to as the critical value if:

1. The ratio of the column's length to its width is large.

2. The element is laterally unbraced.

D. $P_c = \pi^2 EI/L_{\text{eff}}^2$ where P_c = the critical compressive load

E = the compressive elastic modulus

I = the smallest moment of inertia of the cross section

L_{eff} = the effective length

E. The effective length of a column varies with the type of support:

1. For a column pinned at both ends: $L_{\text{eff}} = L$

2. For a column fixed at both ends $L_{\text{eff}} = .5L$

3. For a column pinned at on end and fixed at the other:

$$L_{\text{eff}} = .7L$$

4. For a column fixed only at one end: $L_{\text{eff}} = 2L$

(L = the unsupported height)

F. By providing lateral bracing at mid-height, the critical load is increased by a factor of four.

G. For eccentrically loaded columns, the final stress distribution equals the sum of the stress distributions caused by an axial load and an end moment. The magnitude of the final stress distribution depends on the intensity of the load and the distance it acts from the neutral axis of the column.

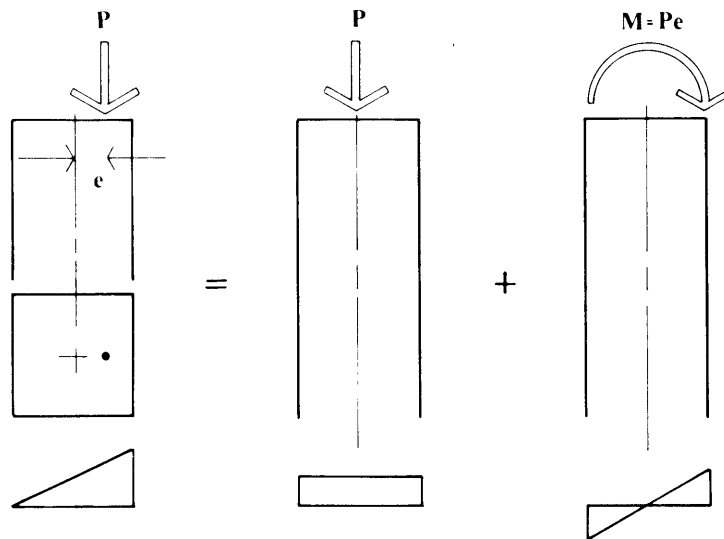

H. A laterally loaded column behaves like a vertical beam. The column must be designed to resist :

1. Transversal shear due to the lateral load
2. Bending stresses due to the lateral load
3. Axial stresses due to the load applied at both ends.

THE SHEAR AND MOMENT DIAGRAMS FOR A COLUMN FIXED AT BOTH ENDS

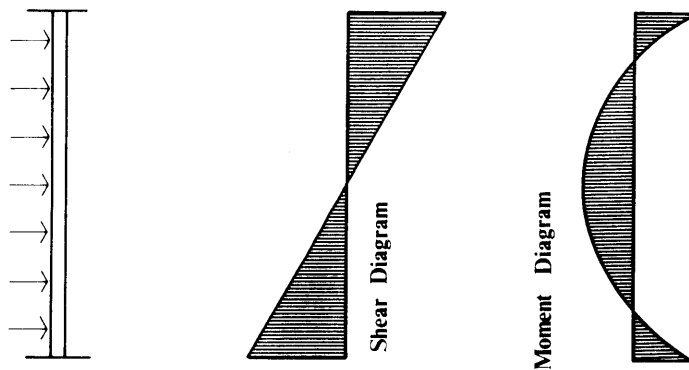

Wood Columns

I. Types And Classifications

A. Varies with section and profile

1. Solid

2. Built-up: consists of smaller members glued or mechanically fastened together for their full length.

3. Spaced: consists of members spaced by internal blocking at specified intervals.

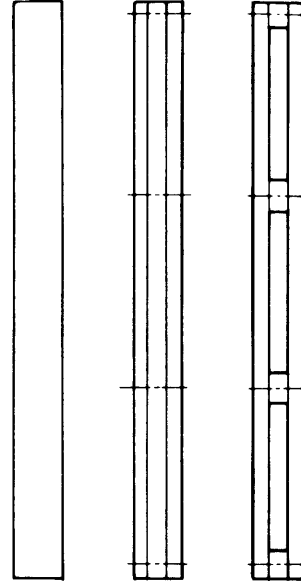
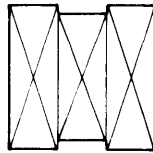
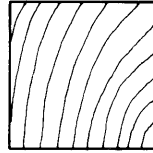

II. Structural Behavior

- A. The allowable compressive stress parallel to the grain of the wood is normally the controlling factor.
- B. Columns should bear on columns and never rest on floor joists.
- C. Built-up and spaced beams should be securely fastened in order that the members act as one unit.

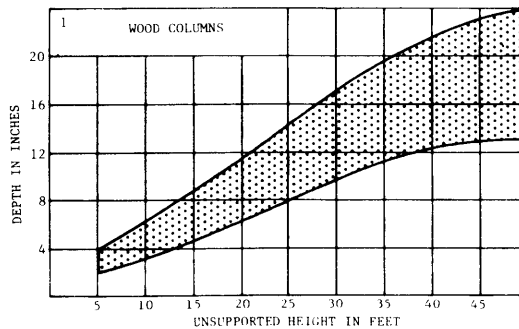

III. Production And Construction

- A. Types of column/ beam connections
 - 1. For continuous beams
 - a. Exposed column caps
 - b. Exposed "T" straps
 - 2. For continuous columns
 - a. Spaced beam/solid column combinations
 - b. Spaced column/solid beam combinations
 - c. Use of steel angles and brackets
- B. Types of column/foundation connections
 - 1. Mechanically fastened to angles
 - 2. Mechanically fastened to steel base plates

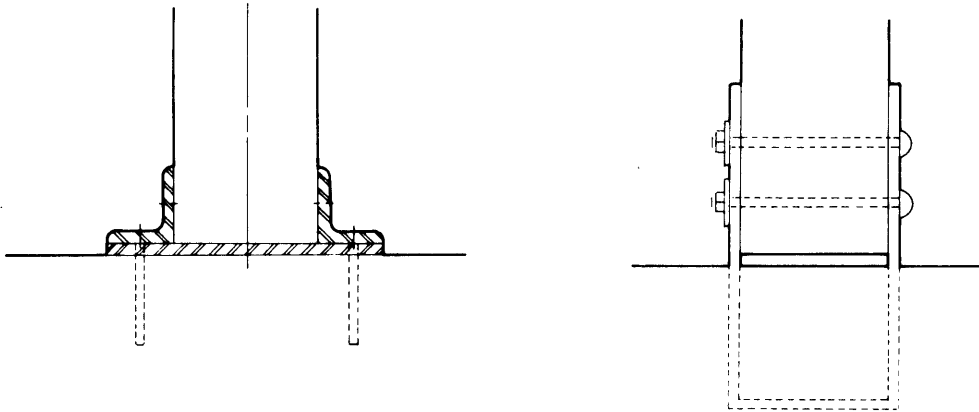

- C. Column spacing is a function of:
 - 1. Desired bay size and geometry
 - 2. Type of horizontal framing system

Concrete Columns

I. Types And Classifications

A. Varies with cross section

1. Columns reinforced with longitudinal bars and lateral ties.
2. Columns reinforced with longitudinal bars and spiral ties.
3. Columns consisting of structural steel sections encased in concrete.
4. Columns consisting of steel tubing filled with concrete.

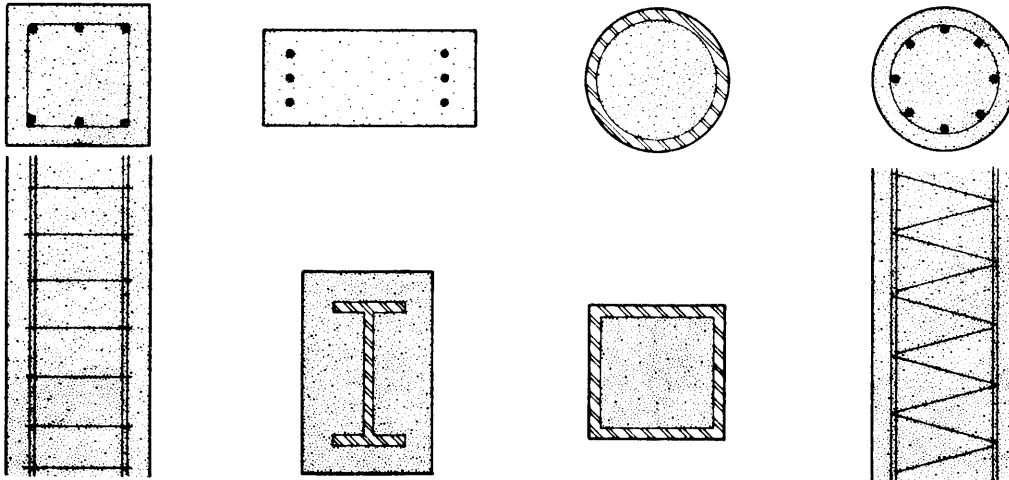

- ### B. The ACI code gives the following rules and allowable dimensions for tied columns:

"All bars of tied columns shall be enclosed by lateral ties, at least No. 3 in size for longitudinal bars up to No. 10, and at least No. 4 in size for Nos. 11, 14, and 18 and bundled longitudinal bars. The spacing of the ties shall not exceed 16 diam. of the longitudinal bars, 48 diam. of tie bars, nor the least dimension of the column. The ties shall be so arranged that every corner and alternate longitudinal bar shall have lateral support provided by the corner of a tie having an included angle of not more than 135° , and no bar shall be farther than 6" clear on either side from such laterally supported bar. Welded wire fabric of

equivalent area may be used instead of ties. Where the bars are located around the periphery of a circle, complete circular ties may be used. Spirals, wires, or rods are specified to be no less than 3/8" in diameter, and the clear spacing between turns of the spiral is stipulated to be no more than 3" nor less than 1"." 6

II. Structural Behavior

- A. The lateral reinforcement in concrete columns functions in two ways.
 - 1. To hold the longitudinal bars in position
 - 2. To resist the outward thrust of the longitudinal bars
- B. For axially loaded columns, the compression strain in the concrete is equal to the compression strain of the steel.

III. Production And Construction

- A. Circular columns may be formed in several ways.
 - 1. By using fiberglass springforms--8" to 36" in diameter (2" intervals)
 - 2. By using fibrous forms--6" to 48" in diameter (2" intervals)
 - a. Seamless finish
 - b. Spiral finish
 - 3. By using steel forms--12" to 48" in diameter (2" intervals)
- B. Rectangular columns may be formed by using plastic, plywood, or other surfaces interlocked with clamps.

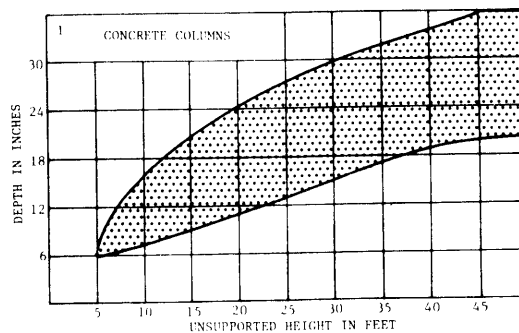

Steel Columns

I. Types And Classifications

A. Varies with section--standard and built-up section may be employed.

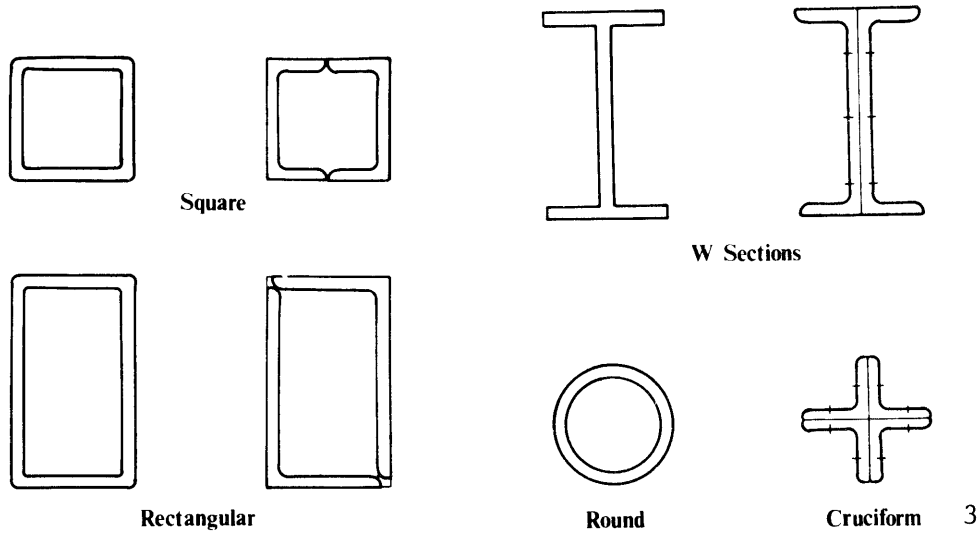

II. Structural Behavior

- A. Column/foundation connections must be rigid in order to transfer column loads and moments, if any.
- B. Column/beam connections must be able to resist shear and any transferred moments

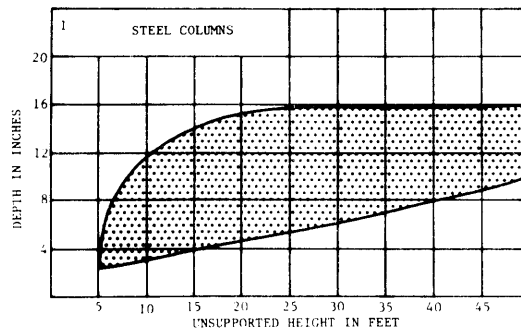

III. Production And Construction

A. Steel columns may either support wood or steel beams.

1. Continuous beam--the use of brackets or plates

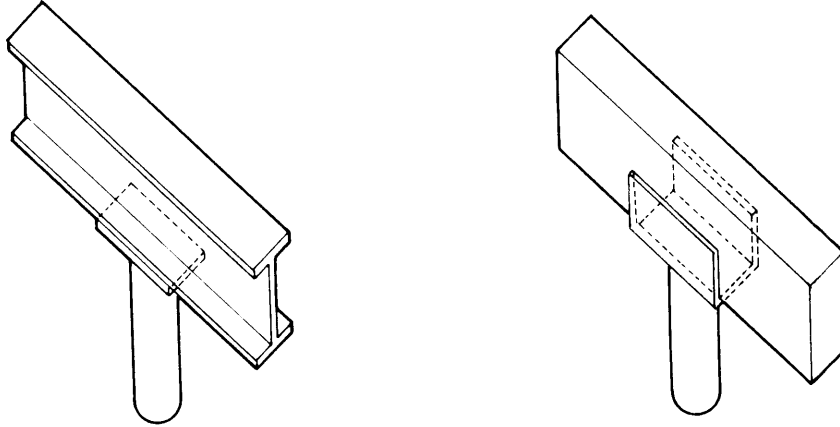

2. Continuous columns--the use of angles and brackets

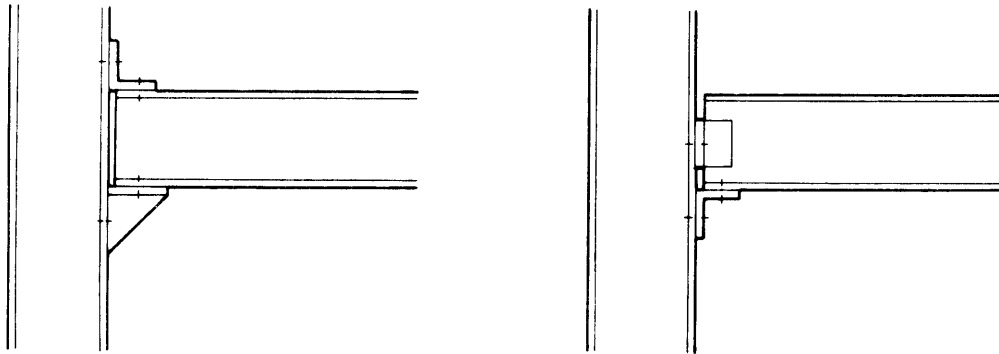

B. Steel columns should be rigidly fixed to the foundation.

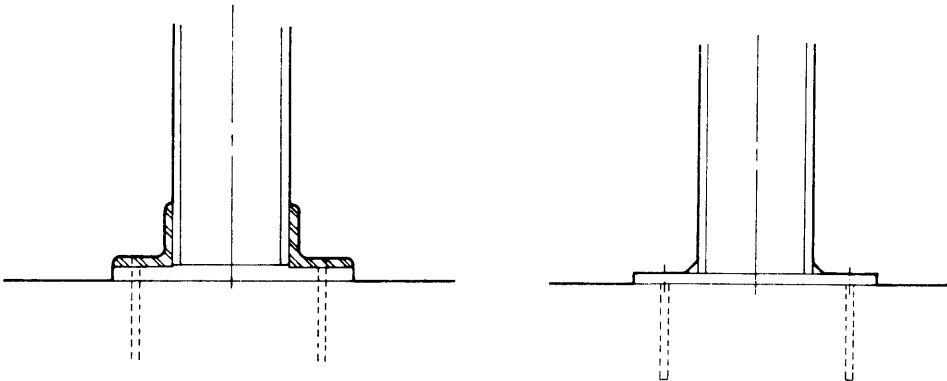

Theory Of Walls

Definition: A bearing wall is a vertical plane which transfers a given load in addition to its own weight.

I. Types And Classifications

- A. Varies with the geometric properties of the wall(s)
 - 1. Length, width, and height
 - 2. Distance and direction of spacing
- B. Varies with the method horizontal structural systems bear on the wall
 - 1. Directly--horizontal structural systems are exposed or cantilevered
 - 2. Framed into the wall--wall is continuous through the height of the building

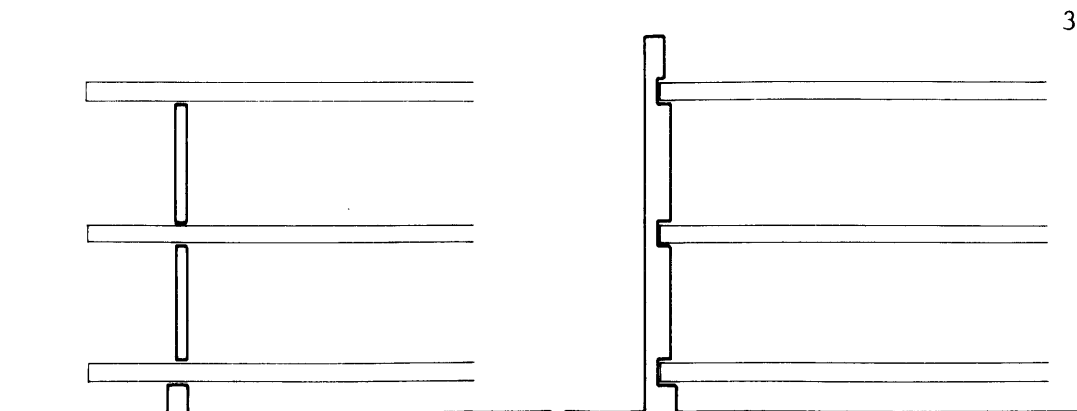

II. Structural Behavior

A. Walls are structurally similar to columns in that a compressive mechanism transfers the load.

B. A wall must primarily resist loads in two directions.

1. Loads along their plane:
dead loads or snow loads

2. Loads perpendicular to
their plane: wind loads

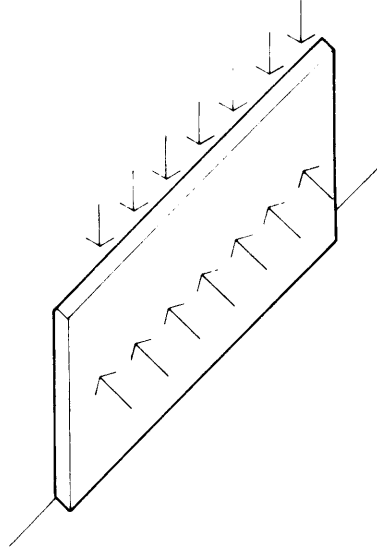

C. A single concentrated load causes stress trajectories to radiate out from the load in compression. This distribution of the vertical components of the load decrease as the distance from the load increases. At the location of the point load, the wall must be designed to resist local crushing or failure.

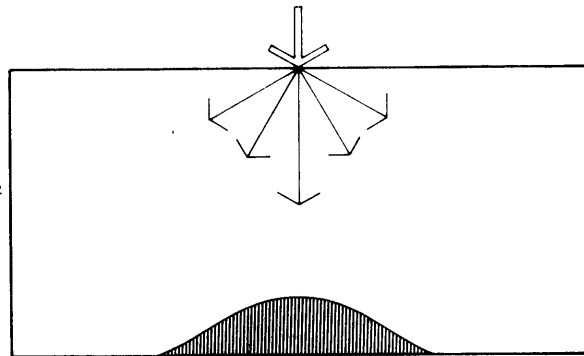

Stress Distribution

D. The lateral stability of bearing walls depends on three factors.

1. Their mass and rigidity
2. Their width to height ratio
3. The amount of lateral bracing

Wood Walls

I. Types And Classifications

A. Varies with type of framing

1. Balloon framing--the vertical studs are continuous for the full building height.
2. Platform framing--the vertical studs are only one story height. This type of framing is adaptable to prefabricated panels and tilt-up construction.

B. Varies with the size of wood studs used and the resulting thickness of the wall.

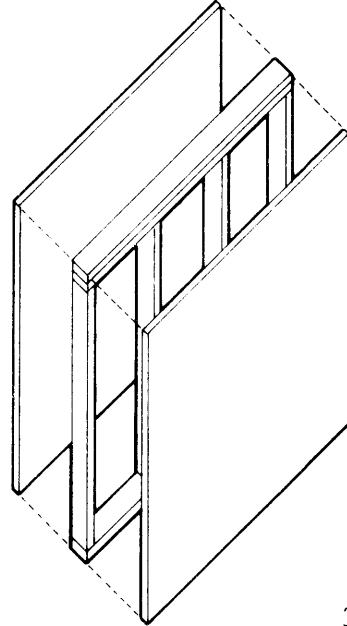

3

II. Structural Behavior

- A. The wood studs transfer the load to the foundation while the wall sheathing aids in resisting the lateral forces.
- B. Stud walls must be adequately anchored to the foundation by bolts in order to prevent uplifting.

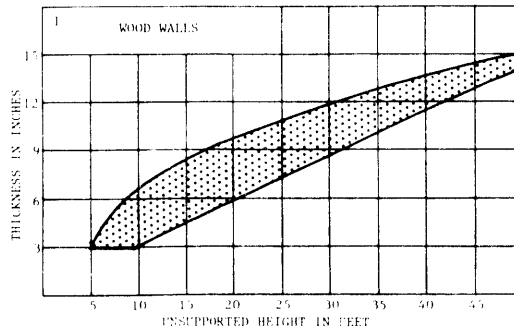

III. Production And Construction

- A. Wood studs are commonly 2x4 spaced 16" or 24" on center. This spacing is based primarily on the available dimensions of the wall sheathing and finish material.
- B. Insulation, vapor barriers, and mechanical or electrical lines may be located within the wall thickness.
- C. The fire rating of the wall depends on the ratings of the wall sheathing or finish materials.
- D. Wood stud walls may be prefabricated into panels on or off the site.
- E. Penetrations are possible and should be coordinated with the location of the vertical studs.
- F. The form of the walls is flexible due to the workability of the material and the various means of fastening that exist.

Concrete Walls

I. Types And Classifications

A. Cast-in-place concrete walls--varies with the method of supporting the slab

1. Directly--used when the slab is to be exposed or cantilevered
2. Framed into the wall--the slab bears on a seat. This method of supporting a slab allows the use of lightweight concrete for the slab and normal weight concrete for the wall.

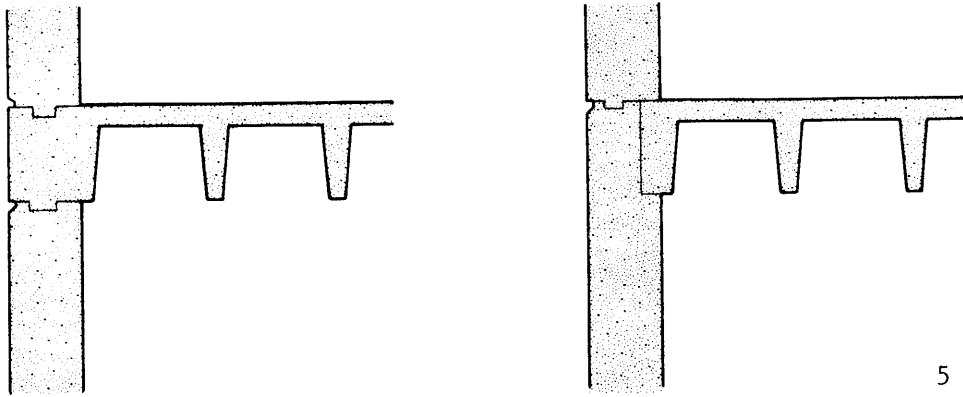

B. Precast wall panels--varies with section and profile

6

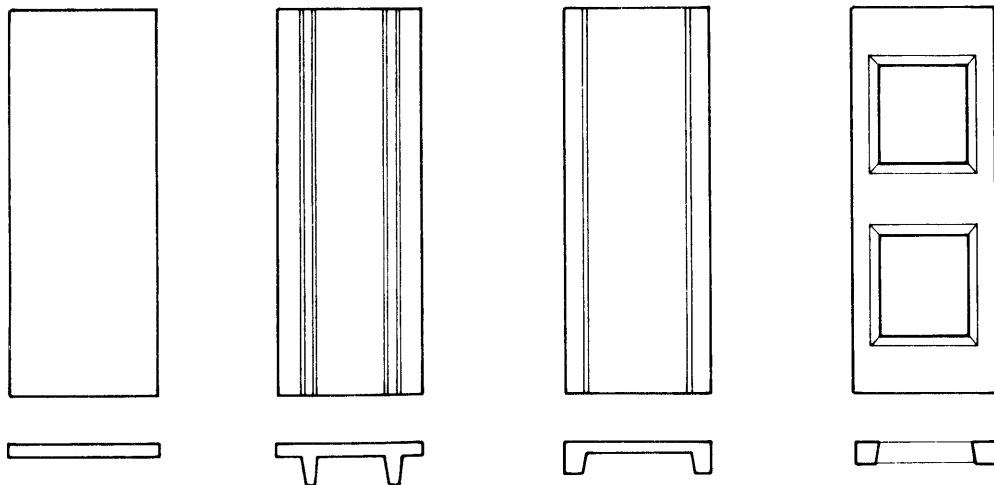

II. Structural Behavior

- A. Bearing walls may be either single or double thickness. If two layers are employed, they must be adequately interconnected so the wall will act as one unit.
- B. The stresses imposed on precast wall panels during erection are usually greater than in the finished structure, and therefore must be designed accordingly.

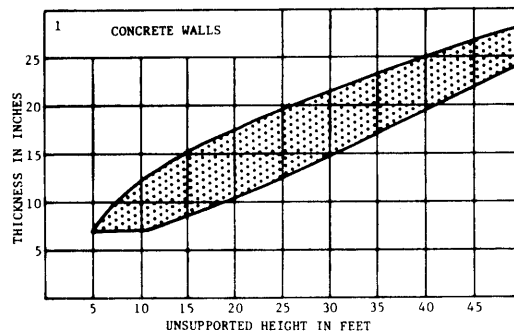

III. Production And Construction

- A. A variety of surface finishes may be provided through the use of special forms, aggregates, or cements.
- B. Insulation may be located between two layers of concrete wall panels or applied to the wall face.
- C. Concrete walls offer excellent fire resistance.

Steel Walls

I. Types And Classifications

A. Varies with type of studs employed

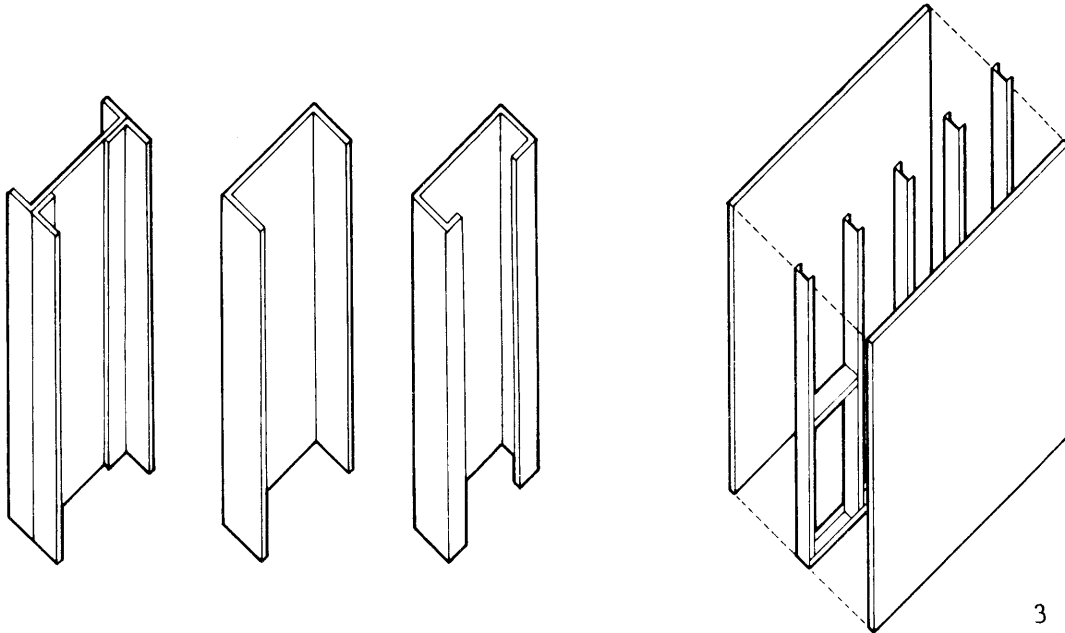

1. Metal studs may be solid, punched, or nailable.
2. Typical widths: $3/4''$, $1''$, $1\ 3/8''$, $1\ 5/8''$, and $2''$
3. Typical depth: $2\ 1/2''$, $3\ 5/8''$, $4''$, $6''$, and $8''$
4. Typical gauges: 14, 15, 16, 18, and 20

II. Structural Behavior

- A. The steel studs transfer the load to the foundation while the wall sheathing aids in resisting the lateral forces.
- B. Steel stud walls are anchored to the foundation by means of a longitudinal channel track.

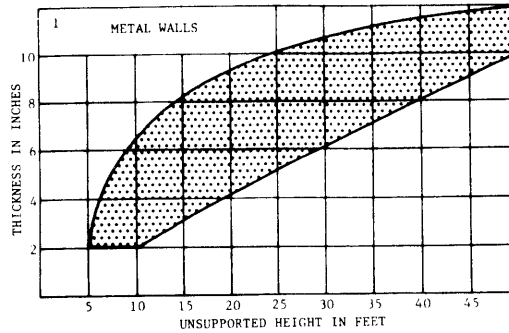

III. Production And Construction

- A. Steel studs are commonly spaced 12", 16", or 24" on center. This spacing is based primarily on the available dimensions of the wall sheathing and finish material.
- B. Steel wall systems are used normally with lightgauge horizontal structural framing systems.
- C. Insulation, vapor barriers, and mechanical or electrical lines may be located within the wall thickness.
- D. The fire rating of the wall depends on the ratings of the wall sheathing or finish materials.
- E. Connections may be achieved either through the use of bolts or welding.
- F. Penetrations are possible and should be coordinated with the location of the vertical studs.
- G. Steel stud walls may be prefabricated into panels on or off the site.

NINE

Materials

Wood And Its Related Technology

Lumber

I. Types And Classifications

A. Classified according to extent of manufacture

1. Rough lumber--Lumber which has not been dressed but has been sawed, edged, and trimmed to the extent of showing saw marks on all four longitudinal surfaces.
2. Dressed lumber--Lumber which has been dressed by a planing machine in order to attain smoothness of surface and uniformity in size. Examples of dressed lumber:
 - a. S1S one side dressed lumber
 - b. S2S two sides dressed lumber
 - c. S1E one edge dressed lumber
 - d. S1S2E one side and two edges dressed lumber
3. Worked lumber--Lumber which has been dressed, matched, and patterned.

B. Classified according to their strength properties

1. Variability of clear wood
2. Specific gravity
3. Type of seasoning
4. Characteristics such as knots or cross grain
5. Duration of stress
6. Temperature

C. The availability of commercial grades based on the previous strength properties varies with species and locality. The following is a list of the most common grades in descending order. Dense select structural, Select structural, Dense No. 1, No. 1, Dense No. 2, No. 2, No. 3, Appearance, Construction, Standard, Utility, and Stud

II. Structural Behavior

A. Structural and physical properties vary according to the type and classification of lumber. The following are typical values for those properties.

PROPERTY	PARALLEL TO GRAIN	PERPENDICULAR TO GRAIN
unit weight	30 to 40 pcf	same
elastic moduli	1.76×10^6 psi	1.1×10^5 psi
coefficient of thermal expansion	2.5×10^{-6} in/in/°F	25×10^{-6} in/in/°F
allowable compressive stresses	1900 psi	450 psi
allowable tensile stresses	1400 psi	

B. Structural lumber is often classified according to size.

1. Joists and planks

- a. 2 to 4 inches in thickness
- b. 6 inches or more in width
- c. Graded with respect to its strength in bending when loaded on the edge as a joist or on the wide face as a plank.

2. Beams and stringers
 - a. 5 inches or more in thickness
 - b. Width is 2 inches or greater than thickness
 - c. Graded with respect to their strength in bending when loaded on the narrow face.
3. Posts
 - a. 5 inches or more in thickness
 - b. Width is not more than 2 inches greater than thickness
 - c. Graded with respect to its strength parallel to the grain.

III. Production And Construction

- A. Preservatives are available to protect the lumber against decay and insect attack.
- B. Fire-retardant treatments are also available.
- C. Both types of treatments may be achieved by two different methods.
 1. Pressure impregnated
 2. Surface applications

Laminated Wood

I. Types And Classifications

- A. Varies with size of laminations
 - 1. Nominal 2" thick lumber is used to produce straight members and curved members having radii of curvature within the bending radii limits of the species.
 - 2. Nominal 1" thick lumber is employed when the bending radius is too severe to use the 2" laminations.
 - 3. The depth of a constant section member is usually a multiple of the thickness of the laminating stock used.
- B. Varies with section and profile
 - 1. Pieces joined end to end to form any length
 - 2. Pieces joined edge to edge to form any width
 - 3. Pieces bent to form curved profiles

II. Structural Behavior

- A. Laminated products are engineered, stress-rated structural members in which several grades of lumber may be used.
 - 1. Higher grades in areas of highest stress
 - 2. Lower grades in areas of lower stress
- B. One should consult manufacturer's catalogs for values of strength related properties.

III. Production And Construction

- A. Laminated members are prefabricated under conditions of controlled humidity, temperature, and cleanliness.

- B. Laminations are inspected before fabrication to locate otherwise hidden defects.
- C. Laminations are also uniformly seasoned in order to reduce the chances of physical defects often found in solid timbers.
- D. Size of the members is also a function of the transportation limitations.
- E. Like solid timbers, laminated members may be treated with preservatives and fire-retardants. Because chemicals used may be incompatible with glues, members are usually treated after fabrication.

Plywood

I. Types And Classifications

- A. Plywood consists of layers of wood glued in such a way that the grain of each layer is at right angles to the grain of each adjacent layers.
 - 1. The outer layers are called faces or face and back.
 - 2. The inner layers are called centers or cores.
- B. Plywood varies with the number of plies and resulting thicknesses.
 - 1. 3 ply: 1/4", 5/16", 3/8"
 - 2. 5 ply: 1/2", 5/8", 3/4"
 - 3. 7 ply: 7/8", 1", 1 1/8", 1 1/4"
- C. Plywood may consist of layers of different thicknesses, species, and grades of wood.
- D. The two main types of plywood panels are:
 - 1. Exterior grade plywood
 - a. The plies are joined with waterproof adhesive
 - b. The faces are C grade or better
 - 2. Interior grade plywood
 - a. The plies are joined with water resistant adhesives
 - b. The faces are D grade or better
- E. Plywood panels are graded according to their faces
 - 1. N grade--all heartwood or sapwood faces
 - 2. A grade--smooth paint faces
 - 3. B grade--smooth solid faces
 - 4. C grade--unsanded sheathing faces
 - 5. D grade--lowest quality of unsanded sheathing faces

F. Most plywood panels are stamped with the following information.

1. Type--interior or exterior
2. Grade--of the faces
3. Group--of wood species

II. Structural Behavior

- A. One should consult manufacturer's data for values of the strength related properties of the type of plywood panel in question.
- B. As previously stated, wood is considerably stronger parallel to the grain than perpendicular to it. Since plywood is composed of grains running in two directions, the cross panel strength is improved. As the number of plies increases, the more equal the strength the panel has in both directions.

III. Production And Construction

- A. Plywood panels are fabricated under controlled conditions of humidity, temperature, and cleanliness.
- B. The standard size of a plywood panel is 4' x 8'
- C. The faces may be treated with preservatives and fire-retardant chemicals.

Wood Nails

I. Types And Classifications

- A. There exists two basic types of nails.
 - 1. Common
 - 2. Threaded
- B. Each type varies with:
 - 1. Material and coatings
 - a. Material--mild steel (the most common), zinc, brass, copper, aluminum, monel, and stainless steel
 - b. Coatings--zinc, tin, copper, brass, nickel, and chrome
 - 2. Length and diameter of shank
 - a. Length--1" to 6"
 - b. Diameter--2 to 15 gauge
 - 3. Shape of heads--flat, hooked, round, oval, cupped, and tapered
 - 4. Pattern of thread--helically or annularly
 - 5. Shape of point--diamond (the most common), round, beveled, and blunt

II. Structural Behavior

- A. A nail resists loads by
 - 1. Lateral strength
 - 2. Withdrawal resistance
- B. Factors influencing the strength of a nail are:
 - 1. Diameter
 - 2. Amount of penetration--usually three times the thickness of the wood to be secured

3. The configuration and slope of the threads if any
 4. Temper of the metal wire
 5. The moisture content of the wood into which the nails are to be driven
- C. Annularly threaded nails are more resistant to axial withdrawal and are used as fasteners of wood to plywood or softwood.
- D. Helically threaded nails are more resistant to bending and are used primarily with hardwoods.

Wood Screws

I. Types And Classifications

- A. There exists two basic types of wood screws.
 - 1. Common
 - 2. Lag
- B. Each type varies with:
 - 1. Type of head
 - a. Slotted--regular or phillips
 - b. Unslotted--(for lag screws) hexagonal or square
 - 2. Material--primarily steel or brass
 - 3. Length
 - a. Common--up to 5"
 - b. Lag--1" to 16"
 - 4. Diameter--0 to 24 gauge
 - 5. The number of threads per inch

II. Structural Behavior

- A. The normal use of these fasteners is either in direct withdrawal or through the development of lateral resistance.
- B. The more threads per inch a screw has, the greater its gripping strength.
- C. Amount of penetration-- $\frac{1}{2}$ to $\frac{2}{3}$ of its length should penetrate the base material

Wood Bolts

I. Types And Classifications

- A. Varies with dimensions
 - 1. Lengths-- $3/4$ " to 30"
 - 2. diameters-- $1/4$ " to $1\ 1/4$ "
- B. Varies with shapes
 - 1. Heads--flat, round, square, or hexagonal
 - 2. Nuts--square, hexagonal, or capped
 - 3. Washers--cut or spring locked

II. Structural Behavior

- A. Bolts produce a clamping force between connected elements which causes a high frictional resistance of the joint. The bolt is in tension and the load is transferred by friction on the surfaces of the materials.
- B. A washer is employed to increase the area of contact between the head or nut and the material to be fastened.
- C. The critical factors in designing a bolted connection:
 - 1. Condition of lumber
 - 2. Number of members to be joined
 - 3. Critical section
 - 4. End and edge distances
 - 5. Spacing

Concrete And Its Related Technology

I. Types And Classifications

- A. Concrete is a material consisting of a carefully portioned mixture of cement, water, sand, and gravel or other aggregate.
- B. The physical properties of the concrete mix may vary due to:
 - 1. The proportions of the constituent materials
 - 2. The type of constituents used
 - 3. The manner in which the concrete is placed, finished, and cured
- C. The types of constituents
 - 1. Cement: Five basic types of cements meet certain physical and chemical requirements established by The American Society for Testing and Materials. The letter 'A' after the number designates air-entraining Portland cement.
 - a. Types I and IA: Normal cement--to be used in general construction where no special properties are required
 - b. Types II and IIA: Moderate cement--to be used in general construction where moderate resistance to sulfate attack is required
 - c. Types III and IIIA: High early strength cement--to be used in general construction where rapid strength is required
 - d. Type IV: Low heat of hydration cement--to be used in massive construction where heat of hydration is slowly dissipated

- e. Type V: Sulfate resistant cement--to be used in special construction where resistance to sulfate attack is the primary concern
2. Water/cement ratio
 - a. Water and cement interact chemically to bind the aggregate.
 - b. The water/cement ratio theoretically determines the potential strength of the concrete. As the amount of water used per unit of cement decreases, the strength of the concrete will increase.
 - c. A certain amount of additional water is required above that needed for the chemical reaction in order to give the mixture a certain degree of workability.
 - d. The water/cement ratio will also affect the durability, weather resistance, and water tightness of the concrete after it has set.
 3. Aggregates vary in order to
 - a. Decrease the weight of the concrete
 - b. Increase the thermal insulating value of the concrete
 - c. Increase the fire resistance of the concrete
 4. Admixtures may also be added in order to
 - a. Entrain air
 - b. Improve workability
 - c. Make the concrete more impervious
 - d. Accelerate or retard the hardening process

II. Structural Behavior

- A. Concrete is normally specified according to the compressive strength it develops after 28 days.
- B. The compressive strength of concrete may vary.
 - 1. 3000 to 4000 psi concrete--the most common type
 - 2. 4000 to 8000 psi concrete--for prestressed concrete
- C. The following are typical values of the structural and physical properties of 3000 psi concrete. Note: 3000 psi concrete equals 8 gallons of water per 94 pound sack of Portland cement.

unit weight	144 pcf
elastic moduli	3×10^6 psi
coefficient of thermal expansion	6×10^{-6} in/in/°F
allowable compressive stress	1350 psi

Reinforced Concrete

I. Structural Behavior

- A. Concrete is not capable of resisting large tensile forces. For this reason, steel reinforcing is located in the tensile region of the element and oriented in the direction of the tensile forces. This reinforcing absorbs the tensile forces while the concrete is usually capable of resisting the compressive.
- B. The structural behavior of a reinforced concrete beam
 1. For relatively small values of bending moments, the concrete is capable of resisting both tension and compression. The resulting distribution of stresses is linear across the depth of the section.
 2. As the bending moment increases, the concrete begins to fail in tension with the exception of parts near the neutral axis where the bending stress magnitude is equal to the ultimate tensile strength of the concrete. It is at this stage when the steel reinforcement provides almost all the tensile resistance and the distribution of the stresses in the concrete remains linear.
 3. With the further increase in bending, the steel resists all tension and the stress distribution of the concrete is almost linear.
 4. Eventually, the tensile stresses in the reinforcing reach their elastic limit and begin to yield plastically. This action is accompanied by a plastic deformation of the

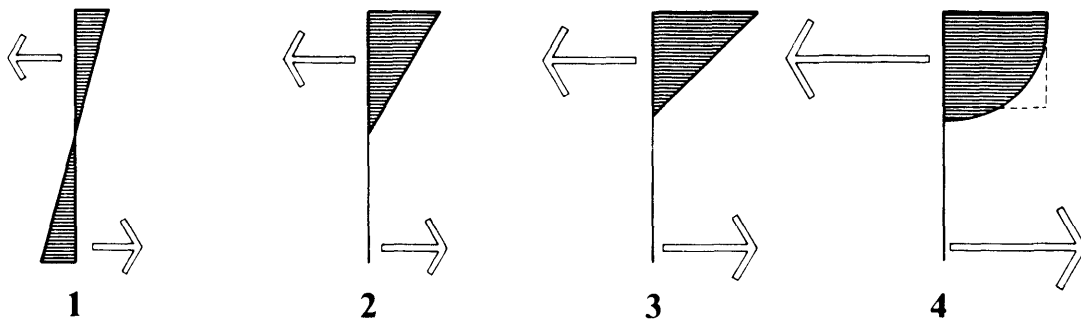

- C. During this process (steps one thru four), a crack slowly develops on the tensile side of the element due to the failure of concrete in tension. This cracking phenomenon is inevitable if the ultimate strength of the reinforced concrete is to be utilized.

Prestressed Concrete

I. Structural Behavior

A. Prestressing is a method of reducing or canceling the stresses due to a load on a member by applying a stress condition to the element before it is loaded.

B. If an axially compressive force is applied, the following stress conditions are possible. (depending on the magnitude of the prestress)

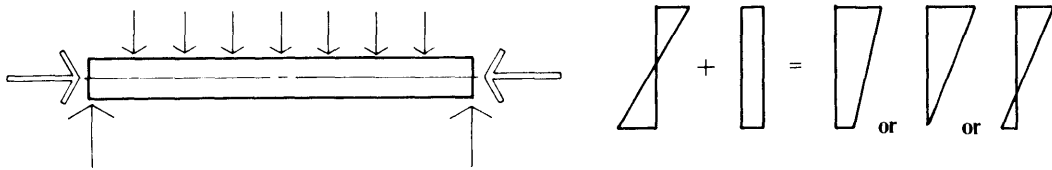

C. Disadvantages of this method

1. The compressive stresses due to the load cannot be reduced.
2. In order to cancel the tensile stresses due to the load, the prestress must be equal in magnitude to the compressive stress caused by the loading.

D. Another method which does not have these disadvantages is prestressing with an eccentric compressive force. Tensile stresses due to the load may be cancelled and the compressive stresses may be reduced.

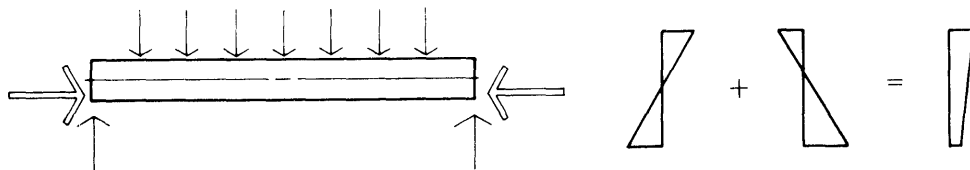

II. Production And Construction

A. Pretensioning

1. The forms are placed and the cables are tensioned by means of a jack.
2. The concrete is poured and allowed to harden.
3. The cable is released and the forms are removed. The cable transfers the prestressing force to the concrete.

B. Post-tensioning

1. The forms are placed and a sheathed or coated cable is installed.
2. The concrete is placed and allowed to harden.
3. The forms are removed and the cables are tensioned by means of a jack. After the stress is applied, the cable is grouted and released.

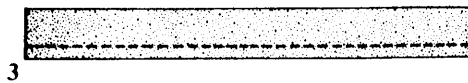
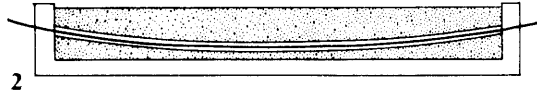
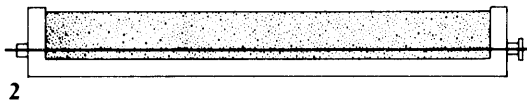
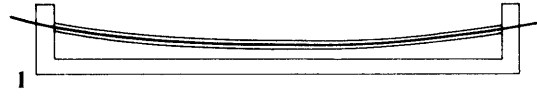
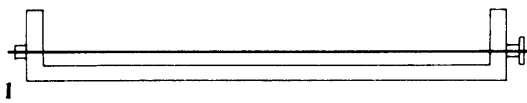

Pretensioning

Post-tensioning

Prestressed Versus Reinforced Concrete

- A. In prestressed concrete
 - 1. Concrete with a higher compressive strength is used--4,000 to 6,000 psi. The reasons for this:
 - a. To permit the development of higher bond stresses with the cables.
 - b. To reduce the initial elastic strain.
 - c. To absorb the high bearing stresses at the ends of the elements.
 - 2. Steel with a higher tensile strength is used--160 to 270 ksi.
- B. For similar sections, prestressed concrete elements may support heavier loads and permit longer spans.
- C. For similar spans and loadings, prestressed concrete elements may have smaller sections.
- D. Cracking on the tensile side of prestressed elements may be reduced or eliminated.
- E. Because prestressed elements are usually fabricated under more carefully controlled conditions, higher strengths and better quality results may be achieved.

Steel And Its Related Technology

I. Types And Classifications

- A. Varies with physical make up
 - 1. Carbon steel
 - a. ASTM A36
 - b. Yield point = 36,000 psi
 - c. The most commonly used steel
 - 2. High strength low alloy steel
 - a. ASTM 440, 441, and 242
 - b. Yield point = 50,000 psi
 - c. Used when weight savings is important or a higher corrosion resistance is desired.
- B. Varies with process of shaping steel
 - 1. Hot rolled--associated with traditional structural shapes
 - 2. Cold rolled--associated with sheet and cladding materials
 - 3. Extruded--associated with cables
- C. Varies with the mechanical and physical properties
 - 1. Welding characteristics
 - 2. Texture, color, and finish
 - 3. Corrosion resistance

II. Structural Behavior

- A. Strength and stiffness of steel is a function of
 - 1. Composition
 - 2. Section
 - 3. Manufacturing process

B. Structural and physical properties vary according to type and classification of steel. The following are typical values for ASTM A36 steel.

unit weight	490 pcf
elastic moduli	29×10^6 psi
coefficient of thermal expansion	6.5×10^{-6} in/in/°F
allowable compressive or tensile stresses	24,000 psi

Welding

I. Types And Classifications

A. Fillet welds

1. Approximately triangular in cross section resulting from joining two surfaces at right angles to each other.

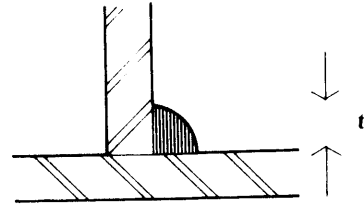

2. The size of the fillet weld is determined by the length of the leg. (denoted by the letter 't')
3. The strength of a fillet weld in shear depends on the critical dimension of the throat. (the throat = $.707t$)
4. Larger welds must be built up of a number of layers.
5. Fillet welds are the most common type of weld.

B. Groove weld

1. This weld is made by depositing the filler metal in a groove between two members to be joined.



2. This type of weld is designed usually for direct tensile or compressive stresses.

C. Plug weld

1. This weld is made by joining one piece of metal to another that is exposed through a hole.

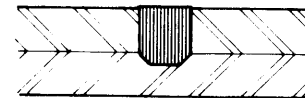

- D. Note: See AISC specifications for details concerning allowable welding stresses and required electrodes.

TEN

References

Sources

The author would like to credit the following sources for technical information and methods of presentation used in this thesis.

1. Architectural Structures, Cowen, Henry J., American Elsevier Publishing Co. Inc., 1971.
2. Structural Systems, Engel, Heinrich, Praeger Publishing Co., 1968.
3. Building Construction Illustrated, Ching, Francis D. K., Van Nostrand Reinhold Co., 1975.
4. Space Grid Structures, Borrego, John, The MIT Press, 1972.
5. Architectural Concrete Norms: Causes and Processes Affecting Performance, Construction, and Appearance. Blewett, Clarence, Massachusetts Institute of Technology Thesis, 1977.
6. Design of Concrete Structures, Winter, G., and Nilson, Arthur H., McGraw-Hill Co., 1972.
7. Steel Space Structures, Makowski, Z. S., Michael Joseph Ltd., 1964.

Additional References

- Callender, John, H., Time Saver Standards: A Handbook of Architectural Design, Fourth Edition, McGraw-Hill Inc., New York, 1966.
- Dietz, Albert G. H., Dwelling House Construction, D. Van Nostrand Co., Princeton, New Jersey, 1966.
- Fisher, Robert E., Architectural Engineering--New Structures, McGraw-Hill Inc., New York, 1964.
- Gurfinkel, German, Wood Engineering, Southern Forest Products Association, 1973.
- Hoyle, Jr., Robert J., Wood Technology in the Design of Structures, Mountain Press Publishing Co., 1973.
- Leontovich, Valerian, Frames and Arches, McGraw-Hill Inc., New York, 1959.
- Lothers, John E., Design in Structural Steel, Prentice-Hall Inc., Englewood Cliffs, New Jersey, 1968.
- Makowski, Z. S., Steel Space Structures, Michael Joseph Ltd., London, 1963.
- McGuire, William, Steel Structures, Prentice-Hall Inc, Englewood Cliffs, New Jersey, 1968.
- National Forests Products Association, "National Design Specifications For Stress--Grade Lumber and Its Fastenings", NFPA, Washington D. C., 1973.
- Popov, Egor P., Introduction to Mechanics of Solids, Prentice-Hall Inc., Englewood Cliffs, New Jersey, 1968.
- Portland Cement Association, "Concrete Floor Systems", PCA, 1973.
- Portland Cement Association, "Concrete Roof Systems", PCA, 1969.
- Ramsey, Charles G. and Sleeper, Harold R., Architectural Graphic Standards, Sixth Edition, John Wiley and Sons, Inc., New York, 1970.
- Salvadori, M., and Levy, M., Structural Design in Architecture, Prentice-Hall, Inc., Englewood Cliffs, New Jersey, 1967.
- Salvadori, M., and Heller, R., Structure in Architecture, Prentice-Hall, Inc., Englewood Cliffs, New Jersey, 1963.

Winter, G., and Nilson, Arthur H., Design of Concrete Structures, Eighth Edition, McGraw-Hill Inc., New York, 1972.

Zuk, William, Concepts of Structure, Reinhold Publishing Corporation, New York, 1963.

