

LIGHT IN ARCHITECTURE

SUBMITTED AS PARTIAL FULFILLMENT OF THE REQUIREMENTS
FOR THE DEGREE OF BACHELOR OF ARCHITECTURE

MASSACHUSETTS INSTITUTE OF TECHNOLOGY
SCHOOL OF ARCHITECTURE

David Shaw

William W. Wurster, Dean

February, 1948

Acknowledgment

At this time the author would like to express his appreciation to Professor L. B. Anderson for permitting the study of this phase of lighting and to Professor Gyorgy Kepes for his patience and guidance during the development of this thesis.

David Shaw

<u>INDEX</u>	<u>PAGE</u>
INTRODUCTION	1
VISUAL ILLUSIONS	11
VISUAL DISTORTION OF SPACE	15
TEXTURE	49
ACCENTS OF LIGHT	49
LIGHT IN STRUCTURE	68
COLOR	68
LIGHT IN MOTION	71
ORGANIZATION OF LIGHT	73
SUMMARY	74
BIBLIOGRAPHY	75

INTRODUCTION

Recent advancement in the science of lighting allow the architects of today to offer the public a wealth of illumination facilities. The three most important types of lamps which have been introduced are the incandescent, electric discharge (sodium, neon, mercury vapor), and fluorescent. The modern incandescent lamp has a filament of drawn tungsten, for this material allows higher operating temperatures than any other known substance. However, most of the energy radiated by incandescent lamps is in the infrared. The lamps are efficient heaters but, unfortunately, not efficient light sources. The tungsten-filament lamp has so many other advantages that it will undoubtedly continue to be used in many places no matter how many more efficacious sources are developed. Some of the important advantages are: (1) Simplicity and low cost, (2) No dangerous high voltages, (3) No auxiliary equipment required, (4) Instantaneous starting, (5) No appreciable flicker or stroboscopic effect on a-c circuits of 50 cps or higher, (6) Works equally well on d-c or a-c, and (7) Acceptable color, little color distortion¹. These advantages, however, are not enough to prevent the use of other types of lamps, if the other lamps have higher efficacy. A large number of gases and vapors have been used in electric discharge lamps in an attempt to attain higher efficacies. Only three of these materials, however, have come into extensive use - sodium vapor, mercury vapor, and neon. Sodium vapor, because of its almost homogeneous radiation gives very bad color distortion and is confined to outdoor lighting. Neon has been used mainly

1. See "Bibliography", page 75, for numbered references.

for advertising purposes and mercury vapor, the most important of the three is used for interior lighting.

Any electric-discharge lamp can be made into a fluorescent lamp by coating the inside of the bulb with a fluorescent material. These so-called phosphors are frequency changers - they change the high frequency radiation of the ultraviolet into low-frequency radiation which may be in the visible spectrum.¹ The principle reasons for the growing use of fluorescent lamps is their high efficacy. The 40 watt white fluorescent lamp gives 44 lumens/watt as compared with 17.5 lumens/watt for the 100 watt incandescent lamp.¹ To partially offset this advantage, there is the higher cost of the fluorescent lamp, the complexity of its auxiliary equipment, and its tendency to flicker. The architect must weigh the merits of the various available lamps in deciding which kind to use.

Today there are a vast number of different kinds of luminaires at the disposal of the architect. The function of these luminaires is to redistribute light or to reduce the unpleasant high helios of bare lamps. In general they may be divided into three types: (1) Direct luminaires, (2) Indirect luminaires, and (3) Diffuse luminaires. The designs are so varied and numerous that it is suggested that the manufacturers' catalogs be consulted for any detailed information.

As a result of intensive photometric research the architect is able to determine the quantitative aspects of lighting solution to satisfy the physical conditions necessary for good seeing. The vague ideas of yesterday have become the precise numerical formulation of

today. A landmark in this progress was the lumen method of photometric calculation developed by Harrison and Anderson in 1916.² Recently this method was given theoretical foundation by means of integral equations and was extended to include helios distributions in the visual field.³ Tables are now available for the predetermination of helios distributions in rooms and for the numerical comparison of lighting designs. In the use of these new methods there is also a need for criteria by means of which the quality of the lighting can be assessed. A number of such criteria have been suggested, notably by Harrison and Luckeish⁴ and Logan⁵. Thus lighting design is tending to become a true engineering discipline instead of a matter of guess work.

There is a tendency on the part of the architect to look upon lighting problems solely from the point of view of the fulfillment of certain optimum photometric conditions. Other aspects of illumination problems should be considered as well. We do not live only on a biological level but also on a psychological and social level. The architect should become aware of the fact that it is not sufficient to satisfy only the biological needs of man.

We see not only with the eye but also with the mind - for the eye is part of the brain as we learn from embryology. The totality of the experience depends upon the psychological influence on the beholder. The psychological factors determine the degree of satisfaction derived from the visual experience. A lighting solution may satisfy all of the engineering criteria and still produce an unpleasant effect. Moon has suggested that part of our psychological evaluation of light may be conditioned by association with similar helios distribution outdoors.¹

As an example he compares the effect of a bright ceiling in a dark room with that effect obtained at the bottom of a well with bright sky overhead. The resultant psychological connotation is gloomy.

Certain aesthetic needs innate in man may also be satisfied by proper use of the tools and techniques of lighting. Aesthetics may be considered in terms of form, color, and texture. According to Birkhoff, the underlying principle in all cases is to obtain the maximum degree of order with a minimum of complexity.⁶ "Beauty is order in complexity."

The architect should remember that in order to create a functional architecture the demands of the eye must be satisfied. To accomplish this he may draw on many visual effects. He may create and control a light shell within an architectural shell. He may organize light to reinforce the functional activities carried on in a given space. He may articulate space visually in order to adapt the environment to various functions. He may also use light as an architectonic element conceiving light as an integral rather than as an extraneous element.

The primary purpose of this report is to survey the possible means by which the architect may organize and articulate light space. The experimental model was built at a scale of 2" = 1'. Although its design is basically that of a living room, it was conceived primarily as a "light box" constructed so that as many typical structural panels as possible could be shown. In some cases it was impossible to use light sources in congruance with the scale of the model. The problem of the actual production of light in these instances will be assumed to be feasible.

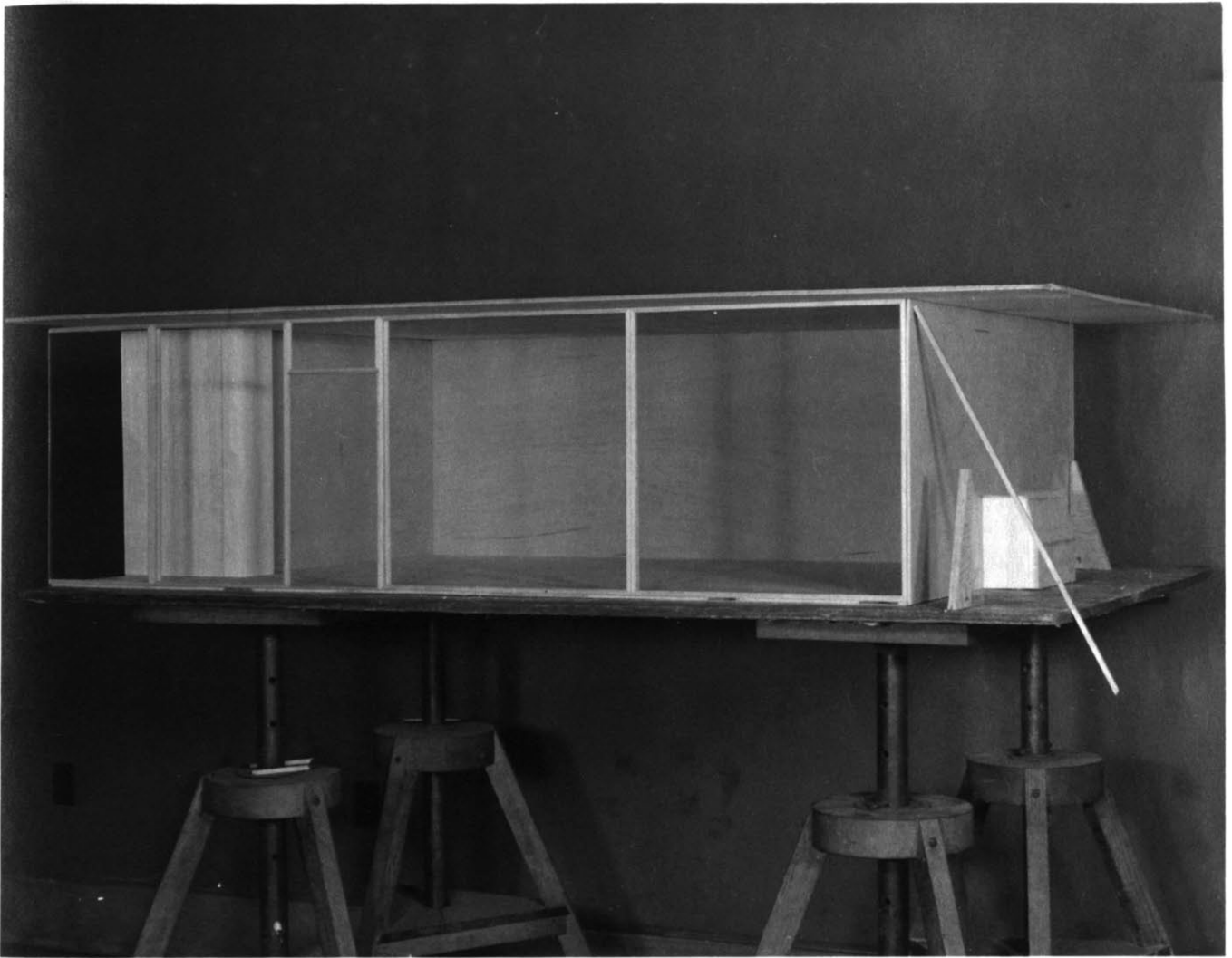

Experimental model - View 1

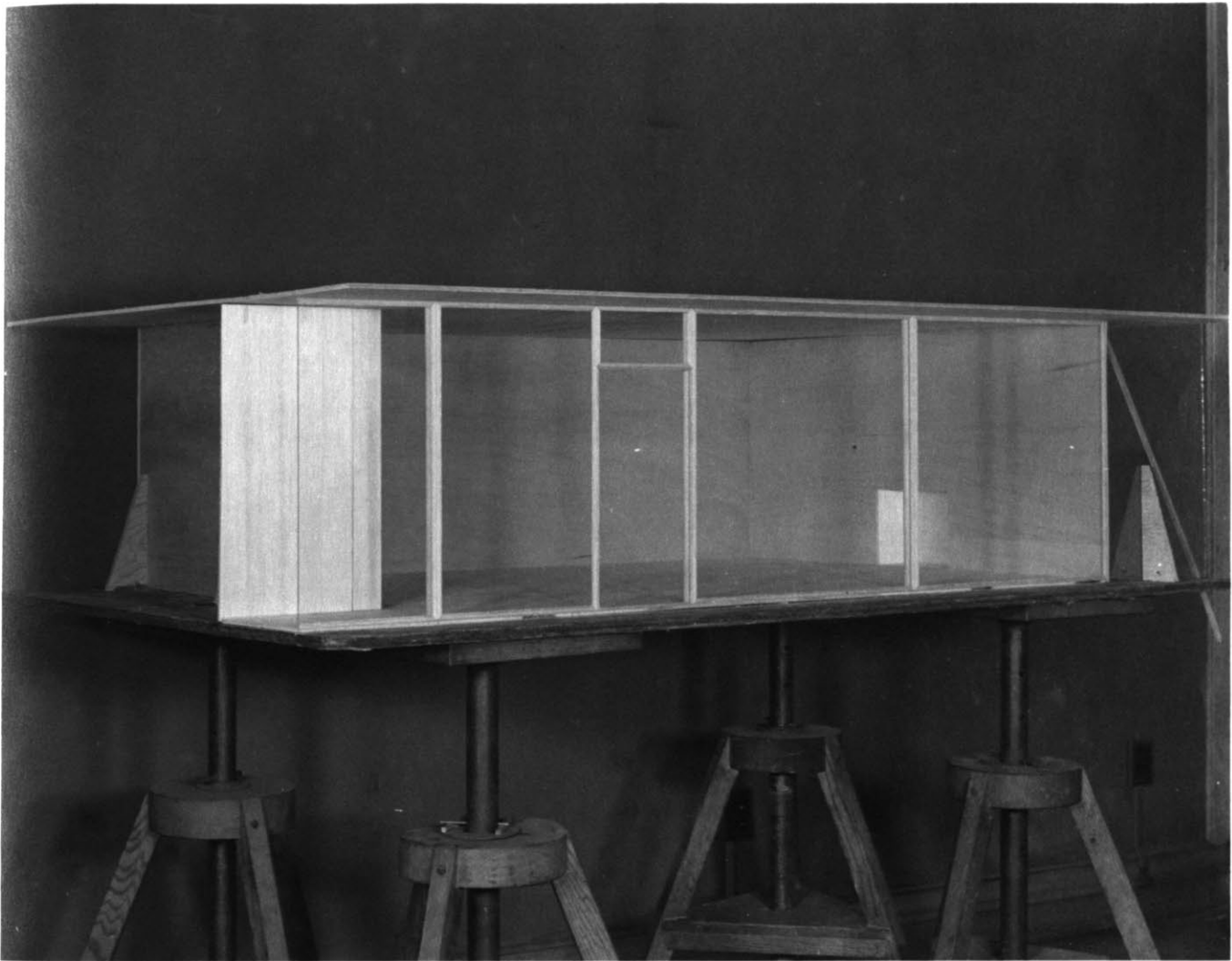

Experimental model - View 2

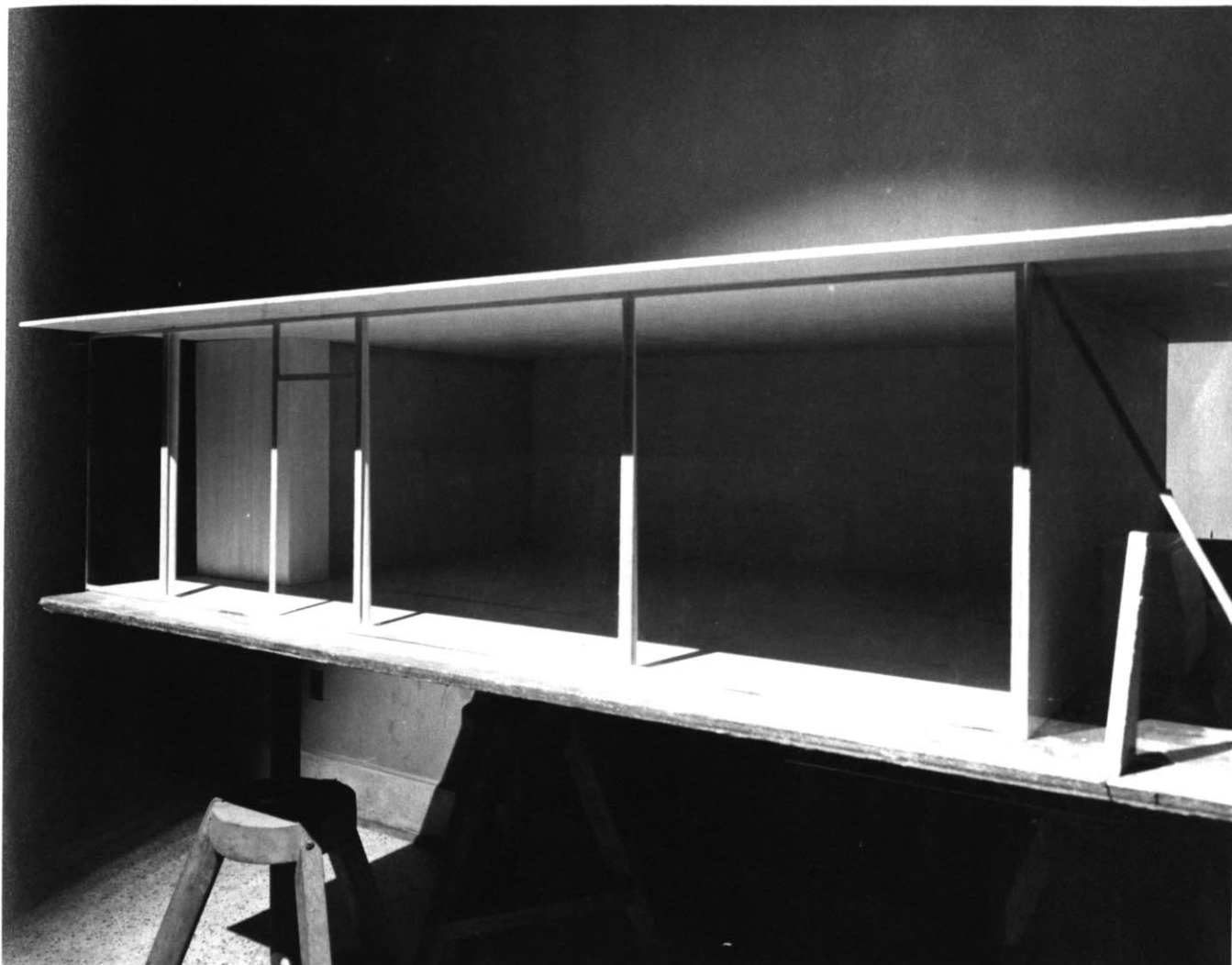

Summer solstice - View 1

Interior - flat white finish

By comparing this and the following photograph with the photographs of Winter solstice it may be seen how architectural expression changes with natural light. This is also an illustration that illumination is not limited to light sources but also to the relationship of reflecting areas. (Note the light ceiling in contrast to the other areas.

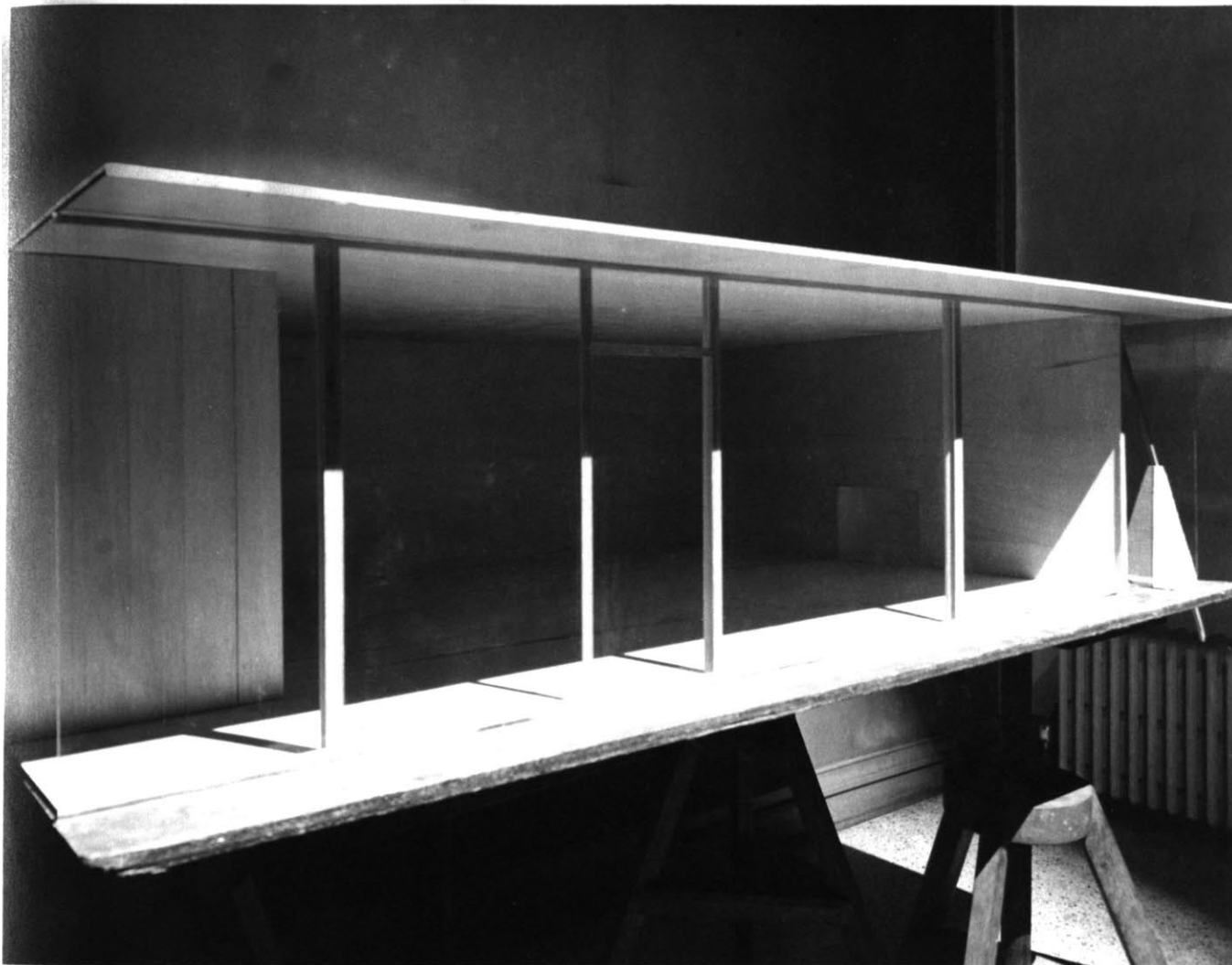

Summer solstice - View 2

Interior - flat white finish

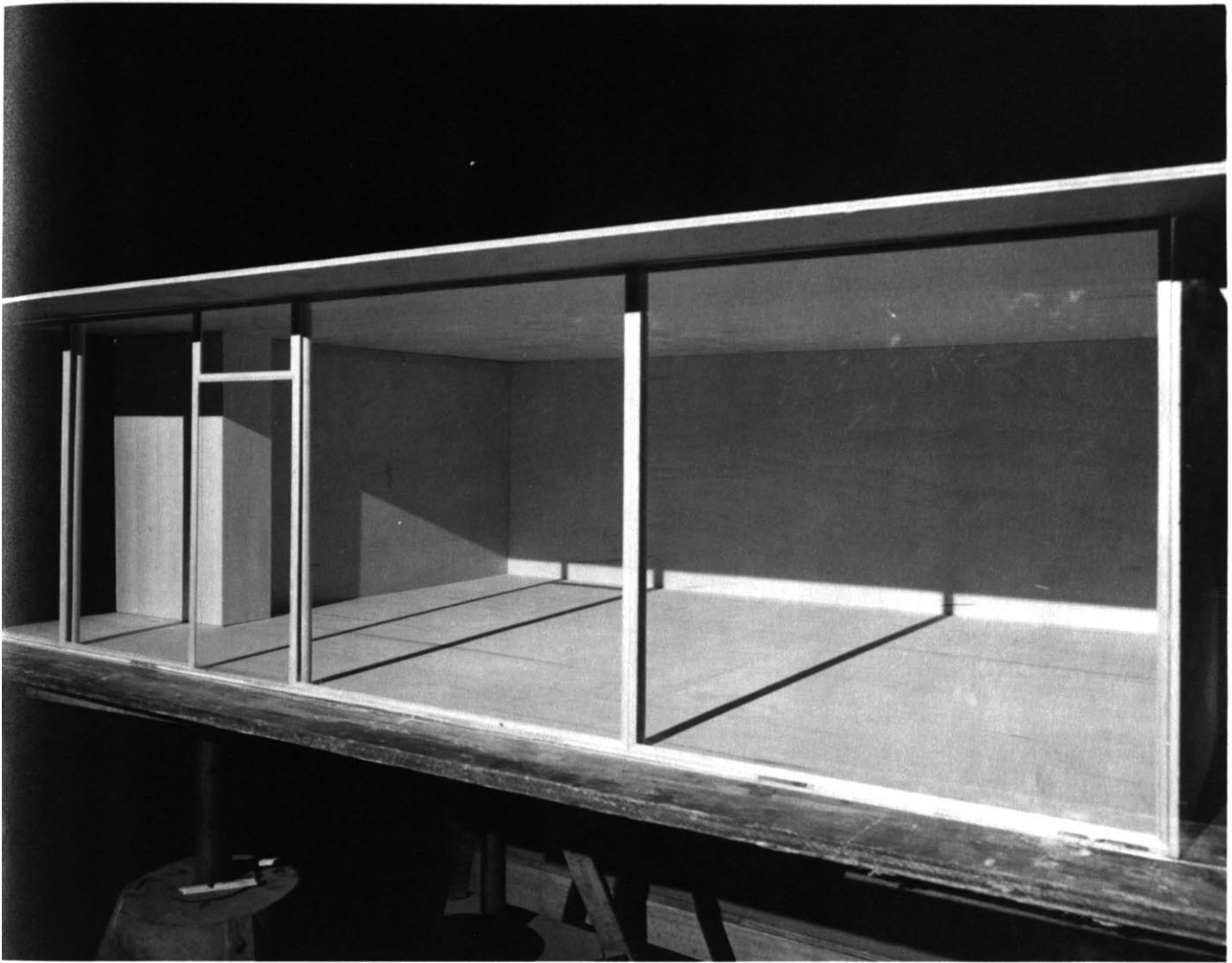

Winter solstice - View 1

Interior - flat white finish

It may be seen in this instance how cast shadow tends to amplify space. Form is defined by the relationship of light and shadow.

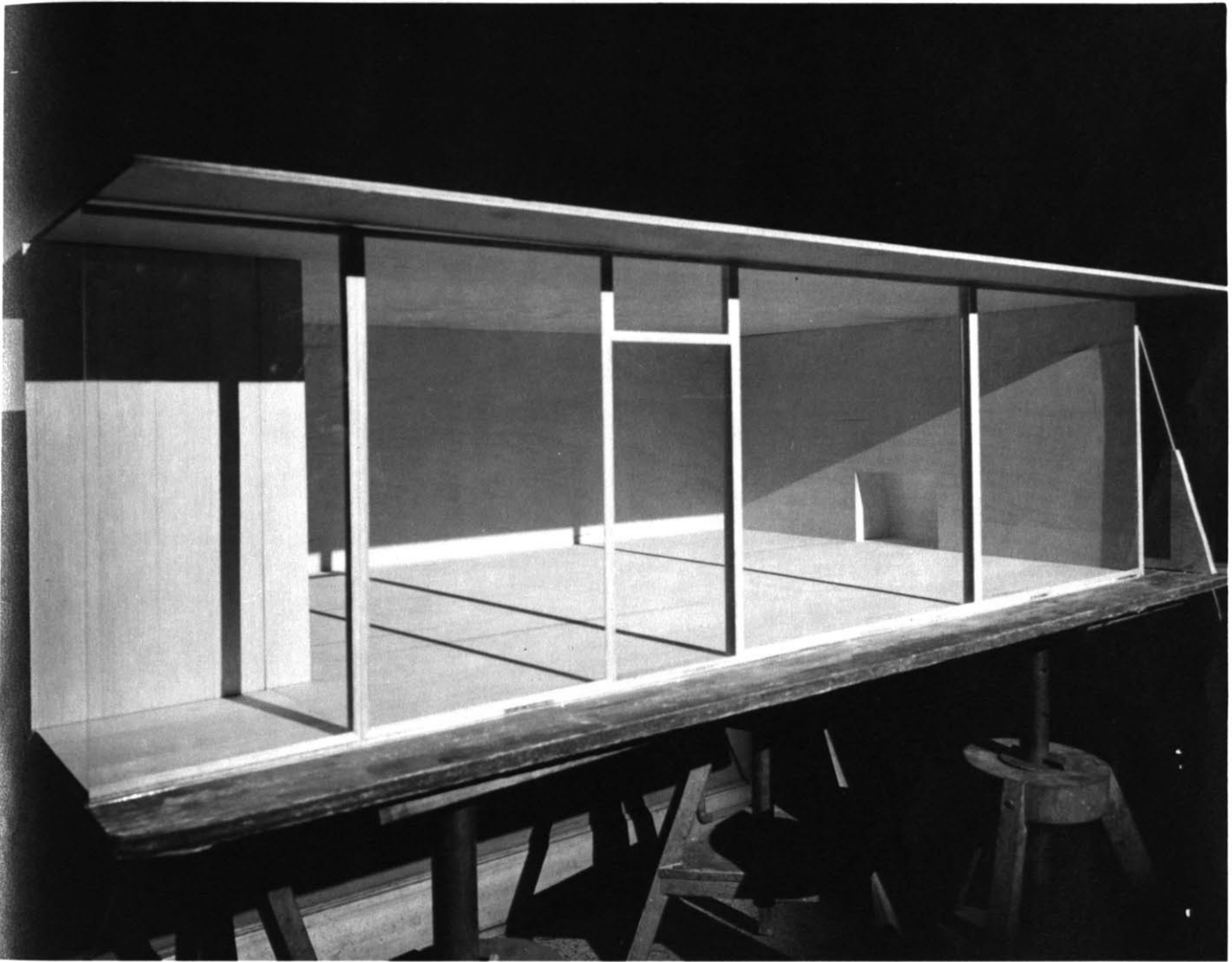

Winter solstice - View 2

Interior - flat white finish

VISUAL ILLUSIONS

The basic approach of this report is to assume that a physical structure exists and to find out how light may be manipulated to achieve any desired visual effects. Before considering the actual experiments it would be well to review the factors influencing the experience of certain effects. The eye is a faulty structure having every defect found in a lens plus a few peculiar to itself. Because of this it is important to have a background of the illusions influencing visual experience.

The phenomenon known as irradiation has been generally defined as a lateral diffusion of nervous stimuli beyond the actual stimulus.⁷ It is not confined to the visual sense but for this sense is a term applied to the apparent enlargement of bright surfaces at the expense of adjacent darker surfaces. The apparent increase in size of the light area is made at the expense of the adjacent dark area. This effect is strongest when the contrast is most extreme, and is apparently accentuated when the accommodation of the eye is imperfect. There are variations in the effects attributed to irradiation, and it is difficult to reduce them to simple terms.

Boswell has described them as follows.⁷ (1) Very rapid spreading of the excitation over the retina extending far beyond the border of the stimulated region and occurring immediately upon impact of the stimulating light. (2) Irradiation within the stimulated portion of the retina after the form of a figure becomes distinctly perceptible. (3) The extension of emanations of decreasing intensity

outward and backward from a moving image until lost in the darkness of the background. (4) Irradiation which occurs when a surface of greatest intensity enlarges itself at the expense of one of less intensity. (5) A form having many characteristics of the first type, but occurring only after long periods of stimulation, of the magnitude of 30 to 60 seconds or more. An obvious form of this effect is illustrated in Figure 1. The small inner squares are of the same size but the white square appears to be larger than the black one.



Fig. 1 Phenomenon of Irradiation

In the illusion of interrupted extent, distance and area appear to vary in size depending upon whether they are filled or empty. Filled or divided spaces generally appear greater than empty or undivided spaces. Apparently the filled or divided space appears more important than the light received from an empty space. The degree of the phenomenon seems to depend upon the obtrusiveness of the filled or divided space. In this phenomenon, as in irradiation, there are other factors which influence the illusion. Consequently no simple rules as to how it will occur can be made. A specific example of this type of illusion is shown in Figure 2. Here the

divided space appears to be greater than the empty space.



Figure 2. Phenomenon of Interrupted Extent

Contrast, with reference to lines and areas, plays another important part in illusory phenomena. In general, parts adjacent to large areas appear smaller and those adjacent to small areas appear larger. A striking illusion of contrast is shown in Figure 3 where the central circles of the two figures are equal, although the one surrounded by the large circles appears much smaller than the other.

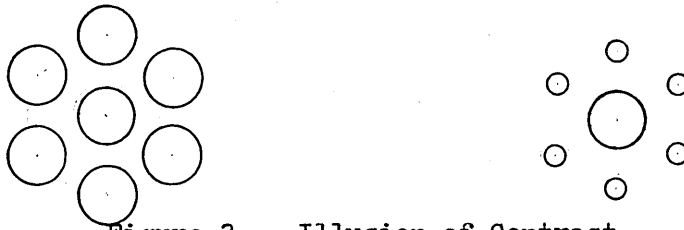

Figure 3. Illusion of Contrast

The orientation of an object in the visual field seems to have an effect on the ability of the observer to judge distance. A pole or a tree is generally appraised to be of greater length when it lies on the ground. This type of illusion persists in geometrical figures. The explanation accepted by some is that more effort is required to raise the eyes through a vertical distance than through an equal horizontal distance.⁷ However, here again the explanation is undoubtedly a complex one and belongs to the realm of the field of physiological psychology. In Figure 4 the vertical line appears

longer than the horizontal line of the same length.

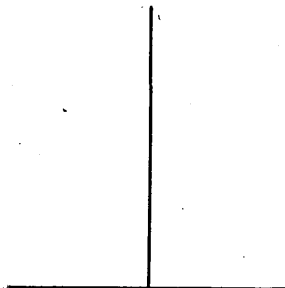

Figure 4. Effect of the Location
in the Visual Field.

The most important illusory aspect of color is the fact that warm colors, the yellows and reds, seem to advance, while the cool colors, the blues and greens, seem to recede. The phenomenon is not very well understood but experimental measurements have shown that it does exist to a marked degree. It is believed that the phenomenon may be attributed to the chromatic aberration of the eye.⁷

The degree to which most optical illusions are experienced is often dependent upon the individual's psychological reaction and upon the influence of experience. Experience may tend to influence a person to think he sees what he wants to see. We are always looking for the most obvious form relationships. The most important justification for the use of light as a tool for producing these illusions is that the degree of illusion and the type of illusion may be easily varied or controlled.

VISUAL DISTORTION OF SPACE

In many cases it is desirable for the architect to create a shell which could have an apparent optimum flexibility. Light may be used as a means of obtaining this flexibility. Light used in this manner is able to reinforce a room's function. It is able to articulate the space visually so that it may be psychologically and physiologically adaptable to various functions. Space may be visually expanded to reinforce gaiety or it may be contracted to reinforce leisure. It must be remembered that this is a visual illusory effect achieved by the use of controlled light and color. It is a psychological experience in light.

In the major part of the experimental work on spatial distortion white light was used and was projected on flat white surfaces. The brightness of the light projected was varied and the extent of the light was controlled.

Variation of brightness of lighting used alone and not reinforced seemed to produce conflicting impressions of spatial distortion. Usually the brightly lighted room, as illustrated on pages 16 and 17, would appear to be light, airy and expanded, but the brightness and clarity of the detail of the walls would often give the observer the impression that the walls had advanced. Under conditions of dim lighting, as illustrated on pages 18 and 19, the lack of brightness would usually give one the impression that the space was closing in and being compressed; however, the lack of detail on the walls would often give the impression that they had receded. The results of observations made seemed to generally indicate that with moderate variation of brightness the space would seem to expand as intensity was raised and would seem to contract as intensity was lowered. It is seen from this that the

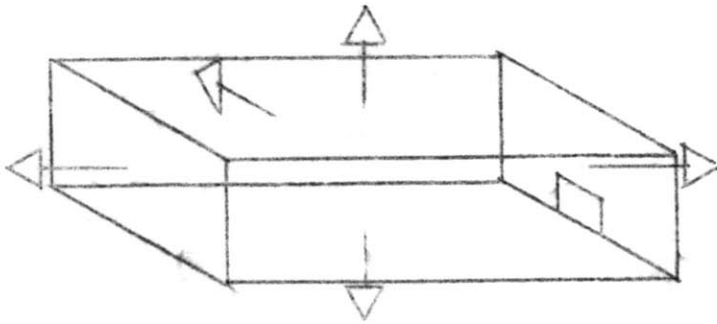
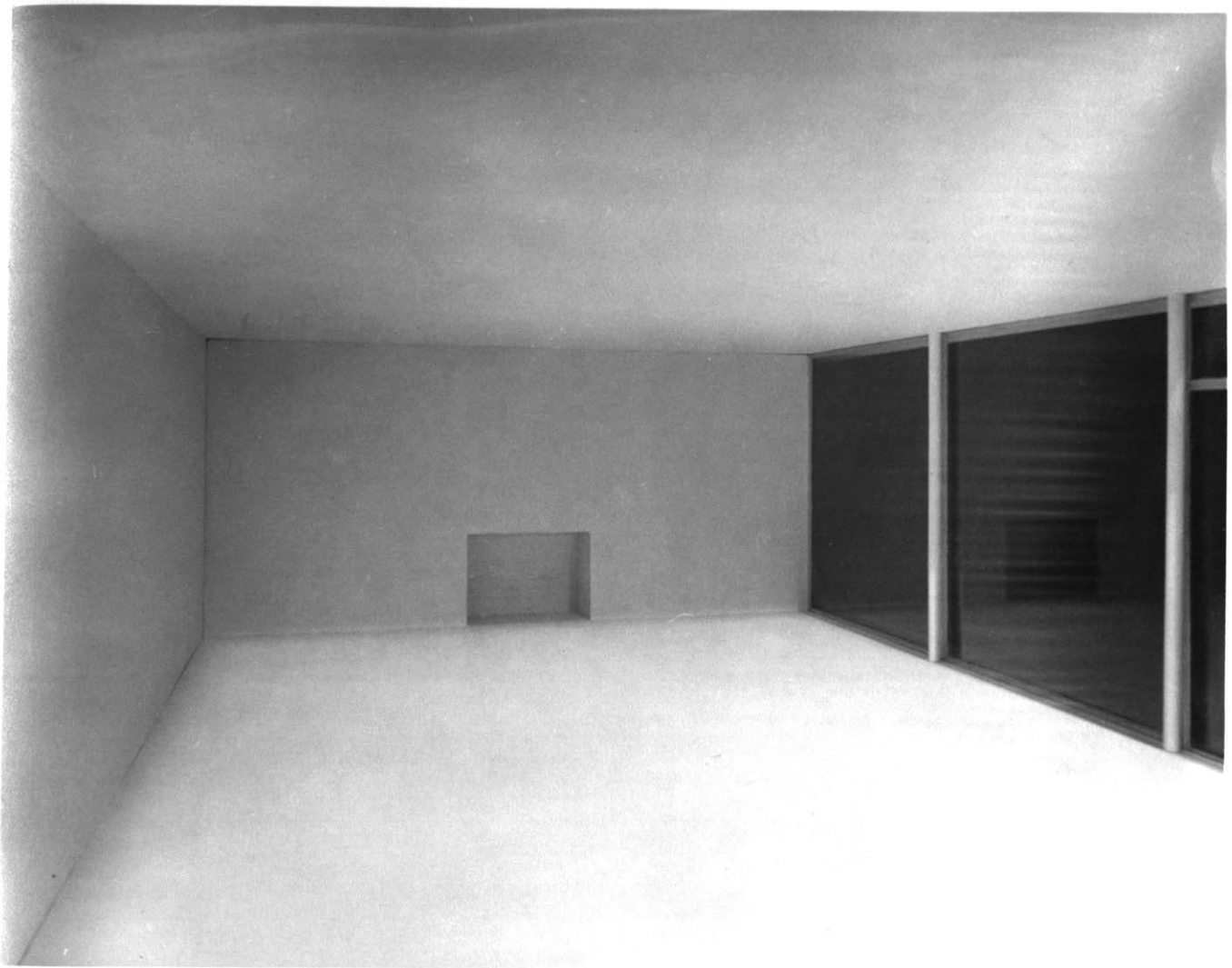

Uniform light of high intensity - View 1

Room seems expanded.

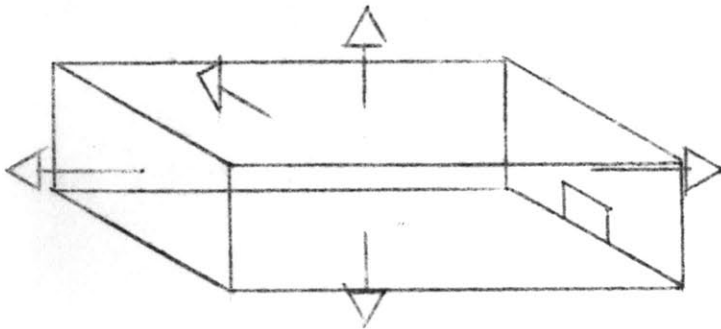
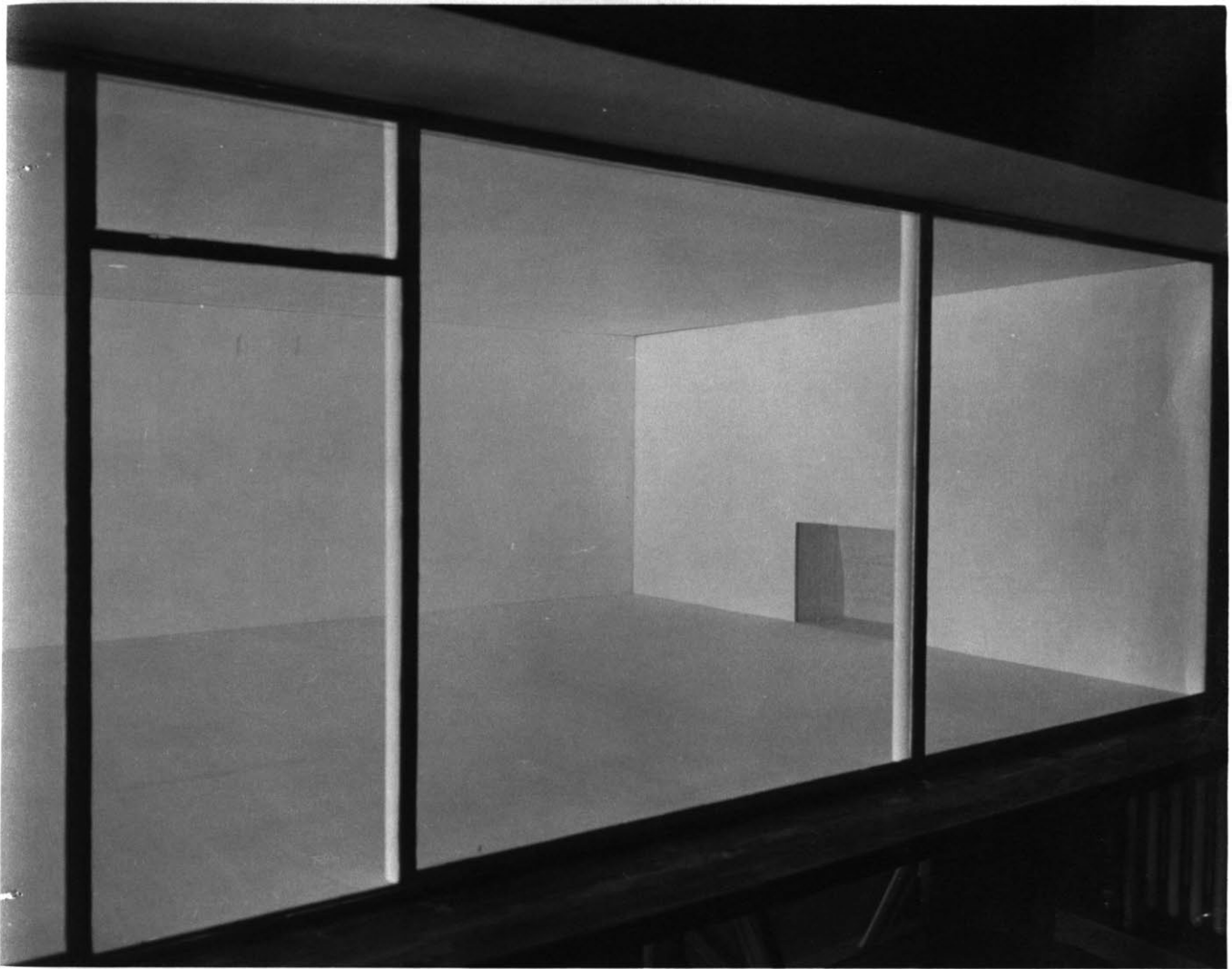

Uniform light of high intensity - View 2

Room seems expanded.

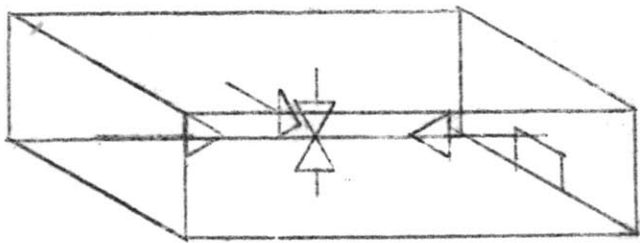
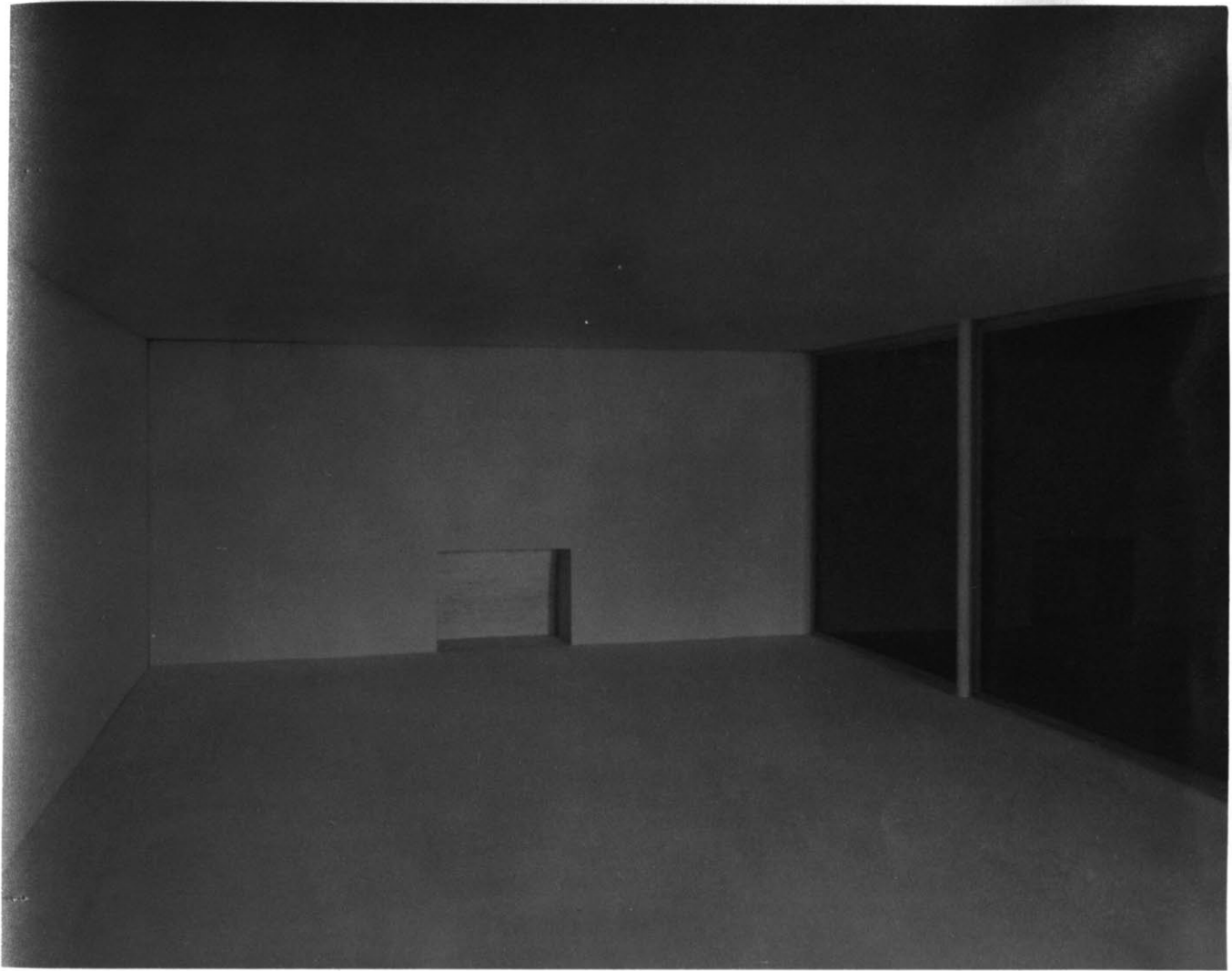

Uniform light of low intensity - View 1

Room seems compressed.

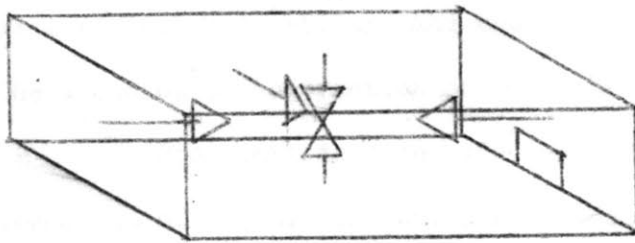
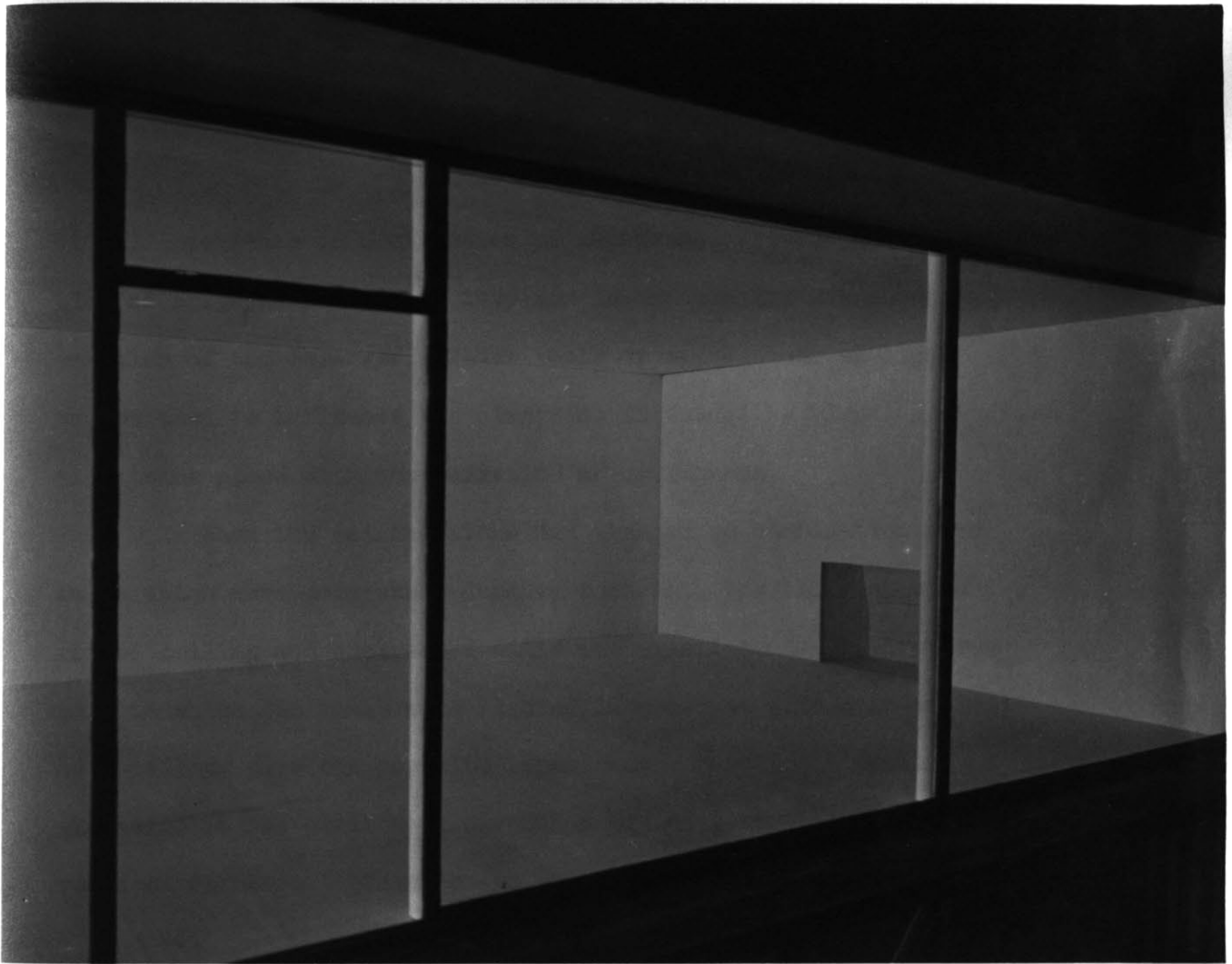

Uniform light of low intensity - View 2

Room seems compressed.

visual experience of contraction or expansion of space by variation of brightness alone is involved in the complex psychological reaction of the observer. Other tools or expressions of light may be used to influence the direction in which the visual articulation takes place with the variation of brightness.

When the ceiling alone was lighted in combination with walls which were moderately dark by contrast, the illusion of a raised ceiling and contracted walls was experienced. The reverse case in which the walls were lighted in contrast with a moderately dark ceiling gave the opposite impression - that is, a feeling of expansion in the horizontal direction and of contraction in the vertical direction. These cases are illustrated on pages 21, 22, 23 and 24.

Pages 25 and 26 show conditions where light was directed at the floor and ceiling, and the walls remained relatively dark. The illusion of contraction of the entire space was experienced.

Observations were made under conditions of controlled gradation of light. The walls were the only surfaces which received light directly and this light was first graded in brightness from top to bottom and later from bottom to top. As illustrated on pages 27, 28, 29 and 30, the most obvious result from observations made under these conditions was that when brightness increases toward the ceiling the ceiling tends to appear to have a floating or suspended quality. The reverse of this was also found to be true in that the floor appeared to be floating when brightness increased toward the

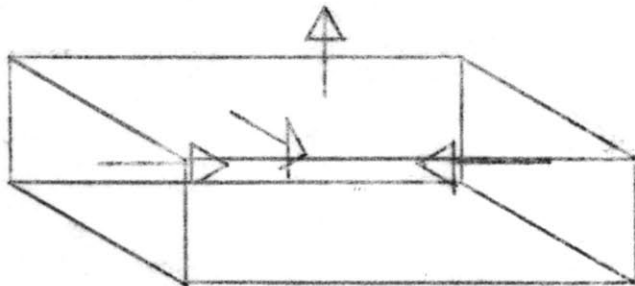
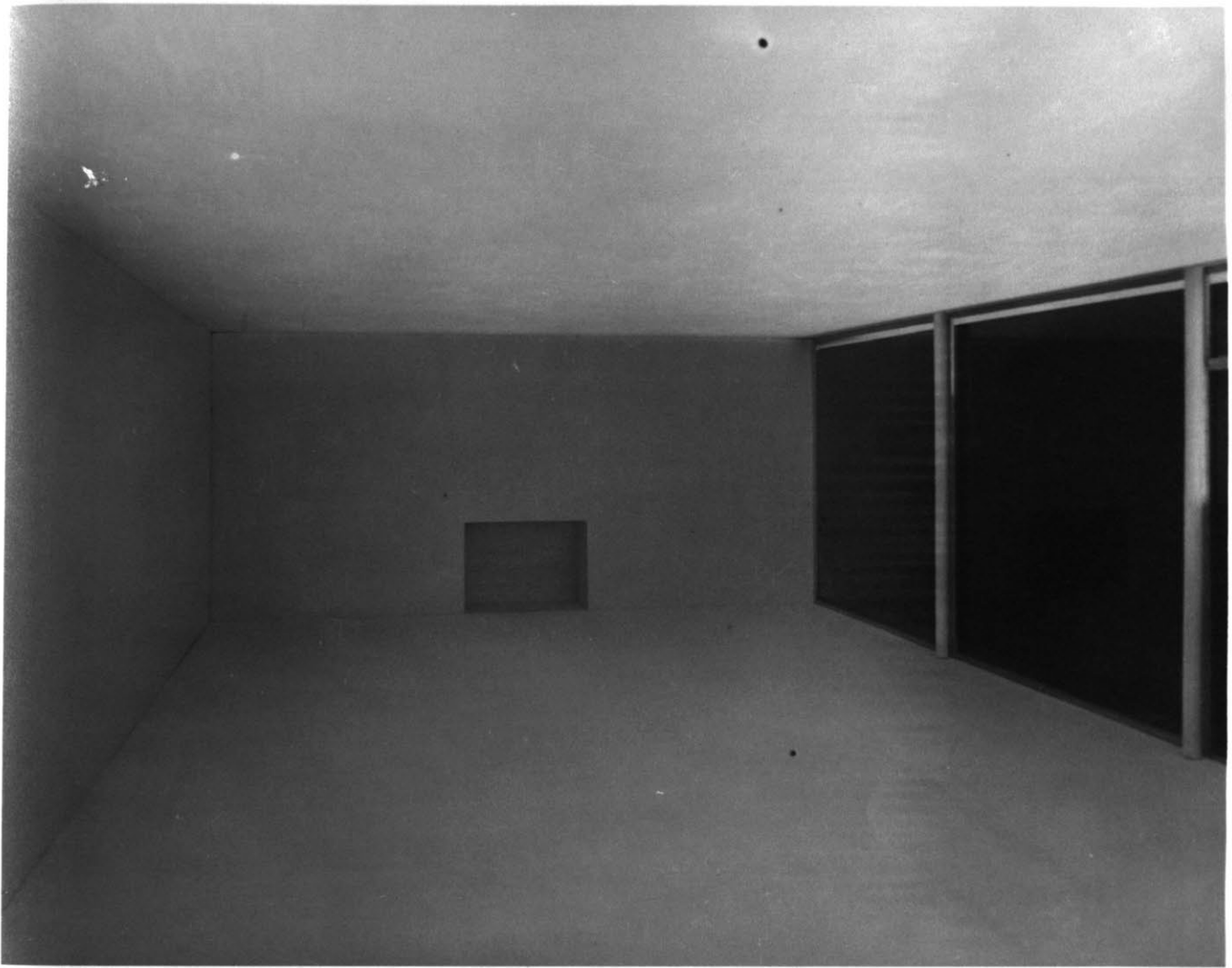

Ceiling lighted - Figure 1

Ceiling seems to expand vertically.

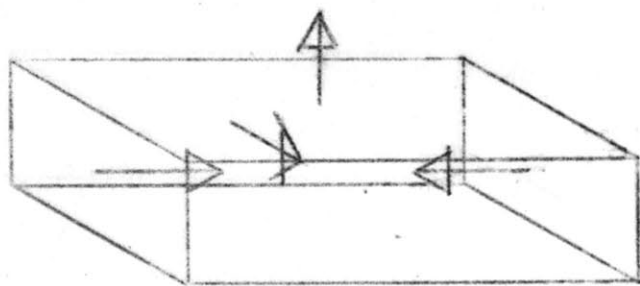
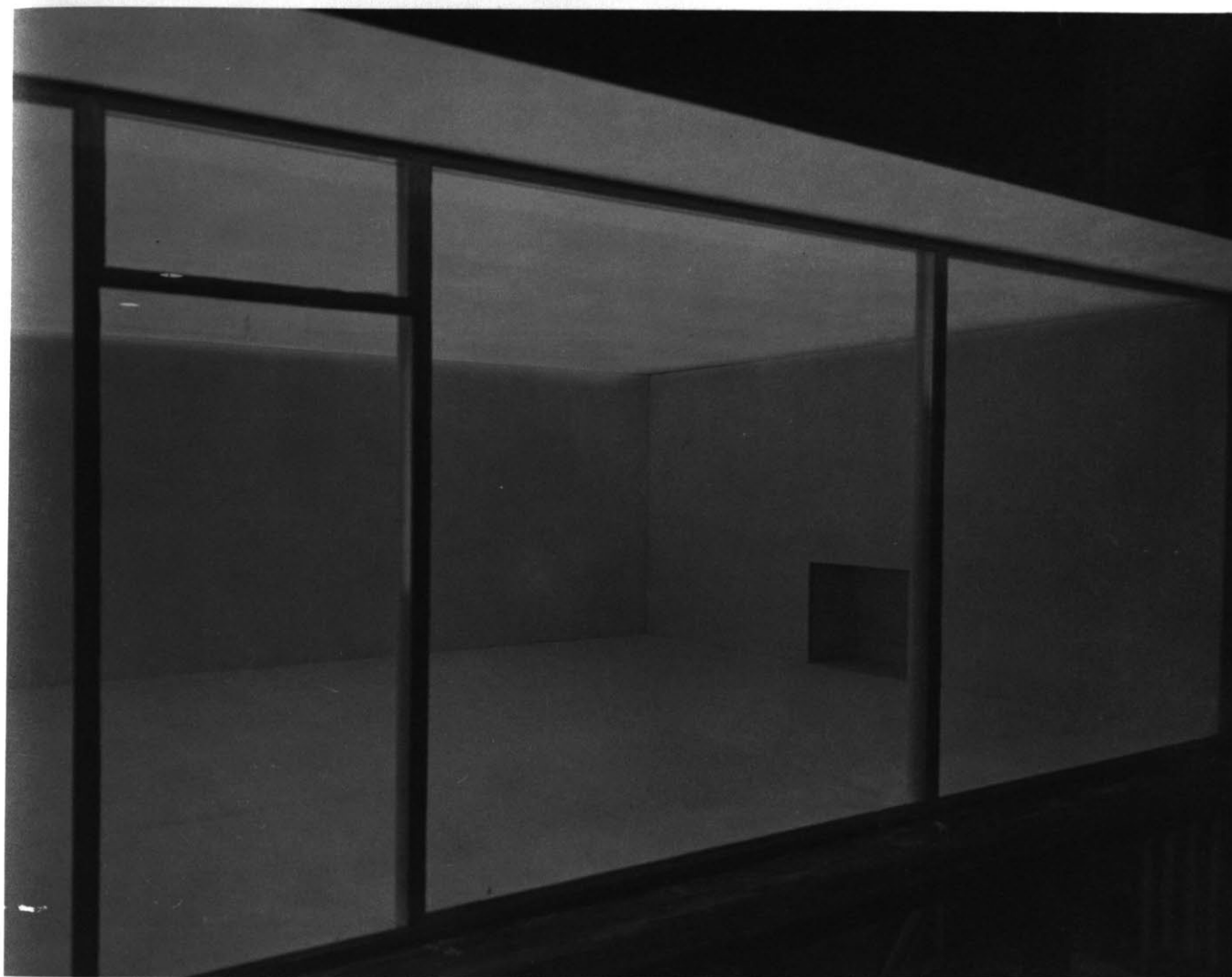

Ceiling lighted - View 2

Ceiling seems to expand vertically.

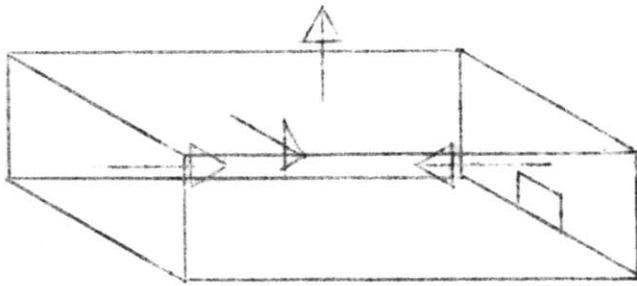
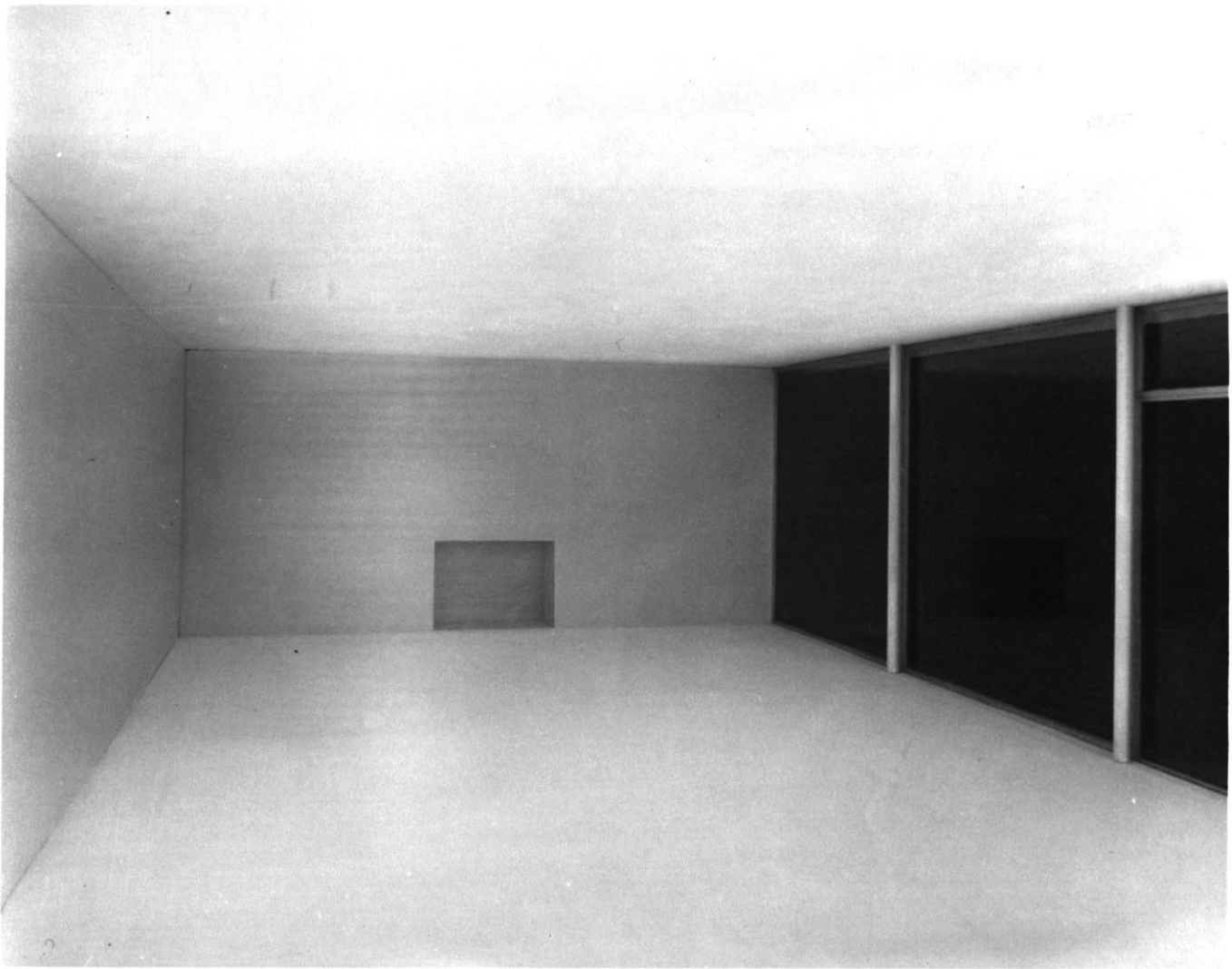

Ceiling and floor lighted - View 1

Room seems expanded vertically and contracted horizontally.

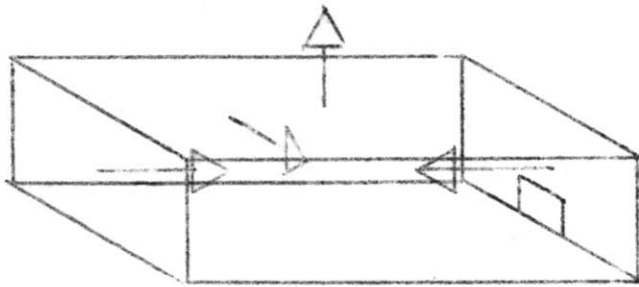
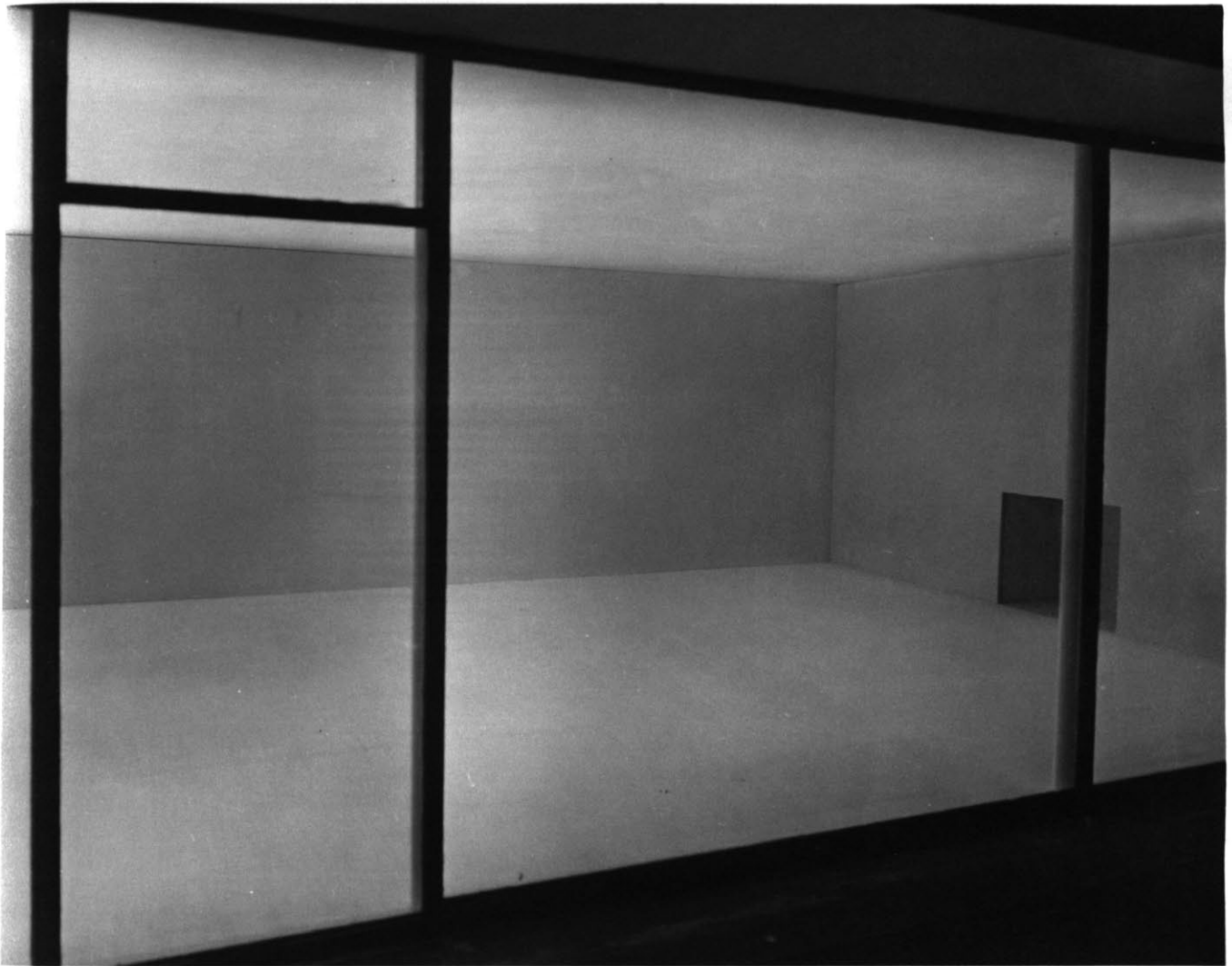

Ceiling and floor lighted - View 2

Room seems expanded vertically and contracted horizontally.

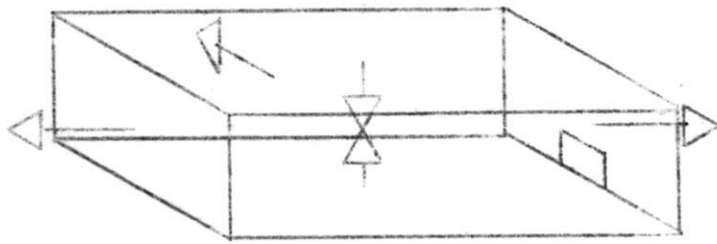
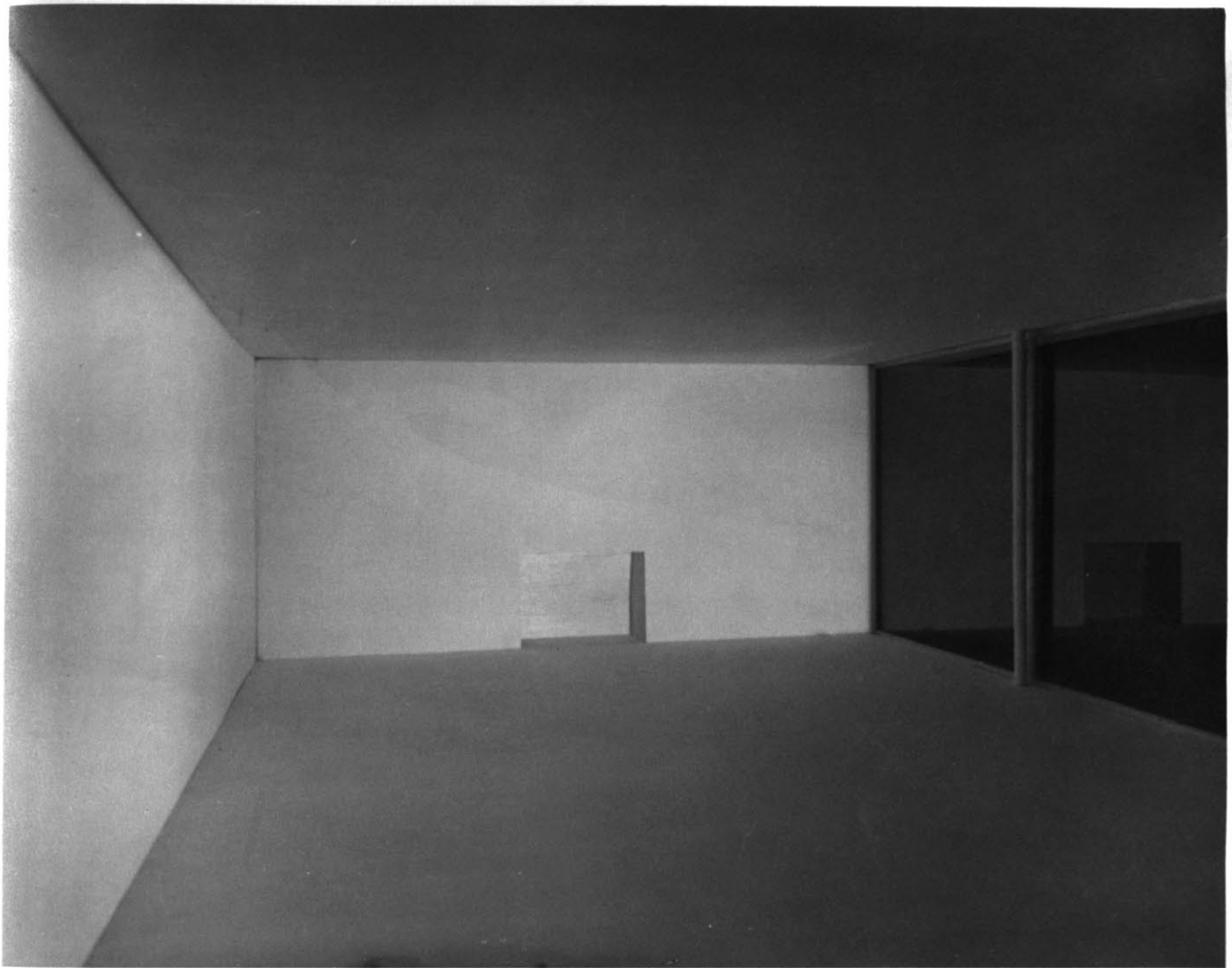

Walls lighted - View 1

Room seems contracted vertically and expanded horizontally.

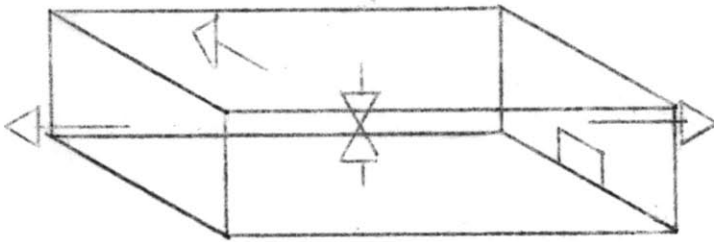
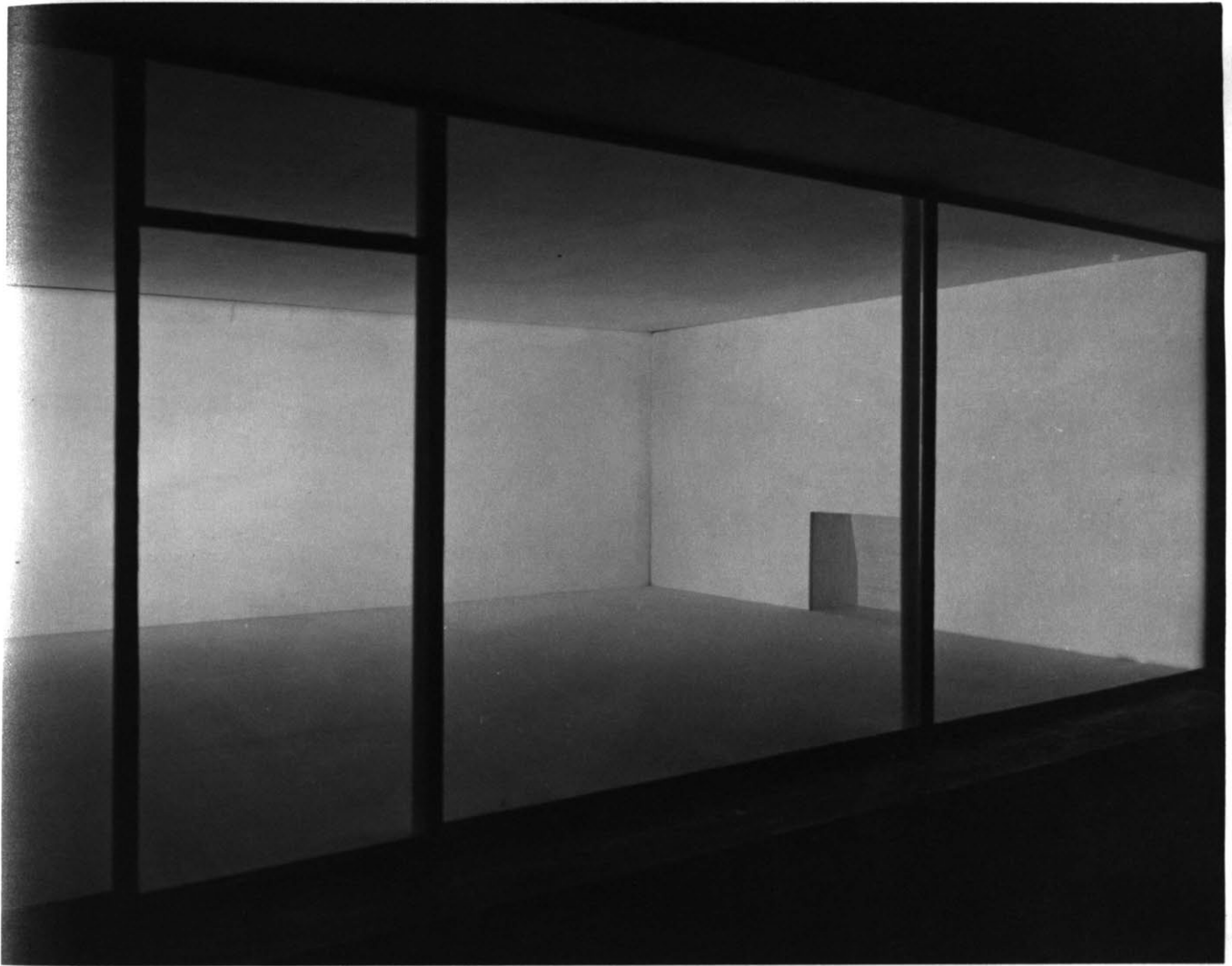

Walls lighted - View 2

Room seems contracted vertically and expanded horizontally.

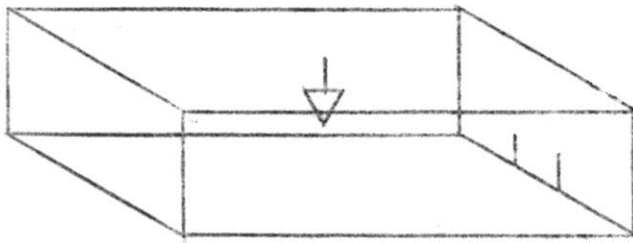
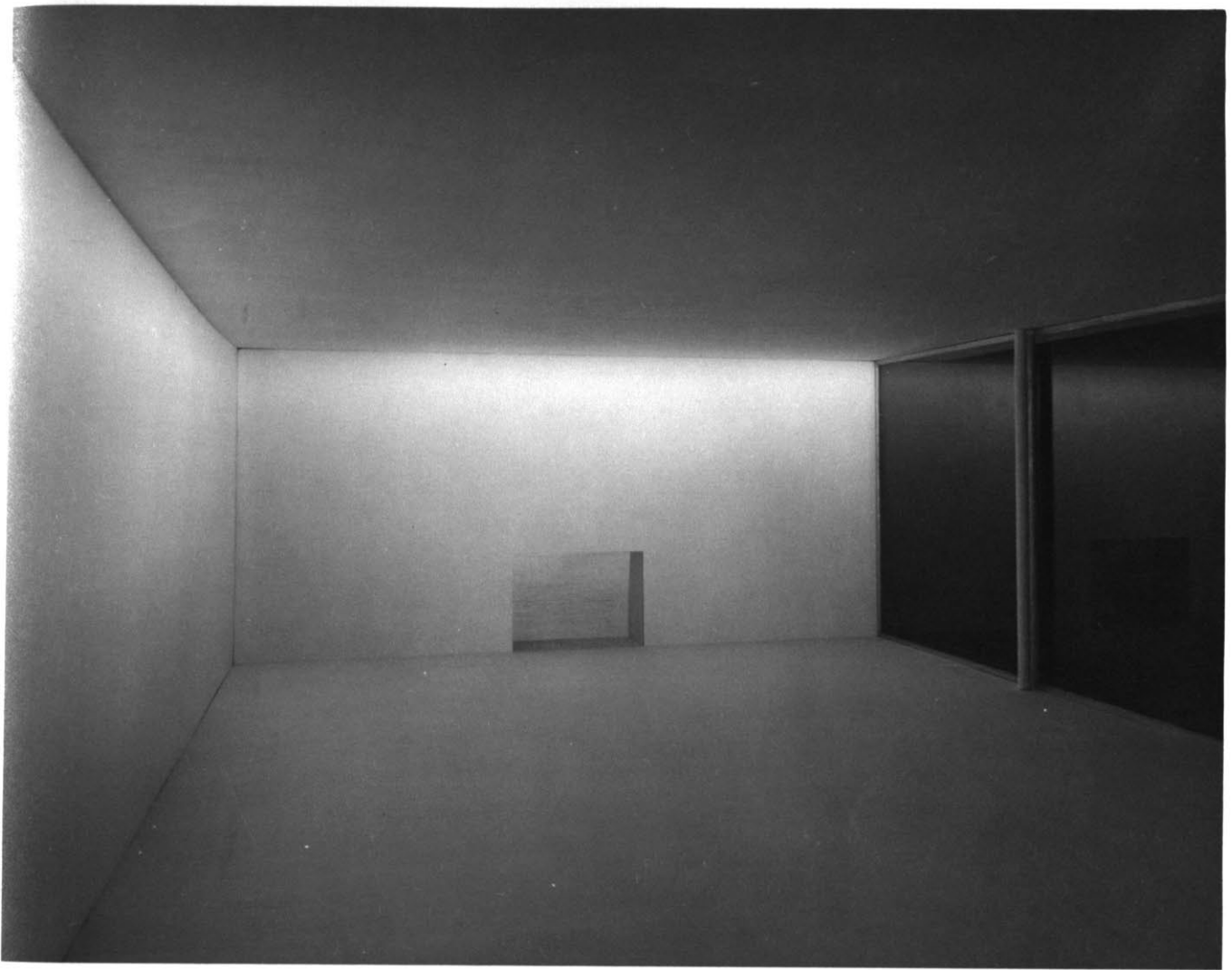

Gradation of light on walls from top to bottom - View 1

The ceiling seems suspended. Walls seem to be accented vertically.

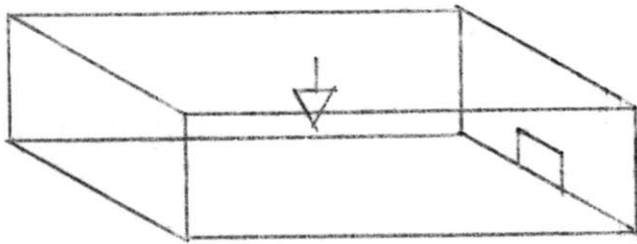
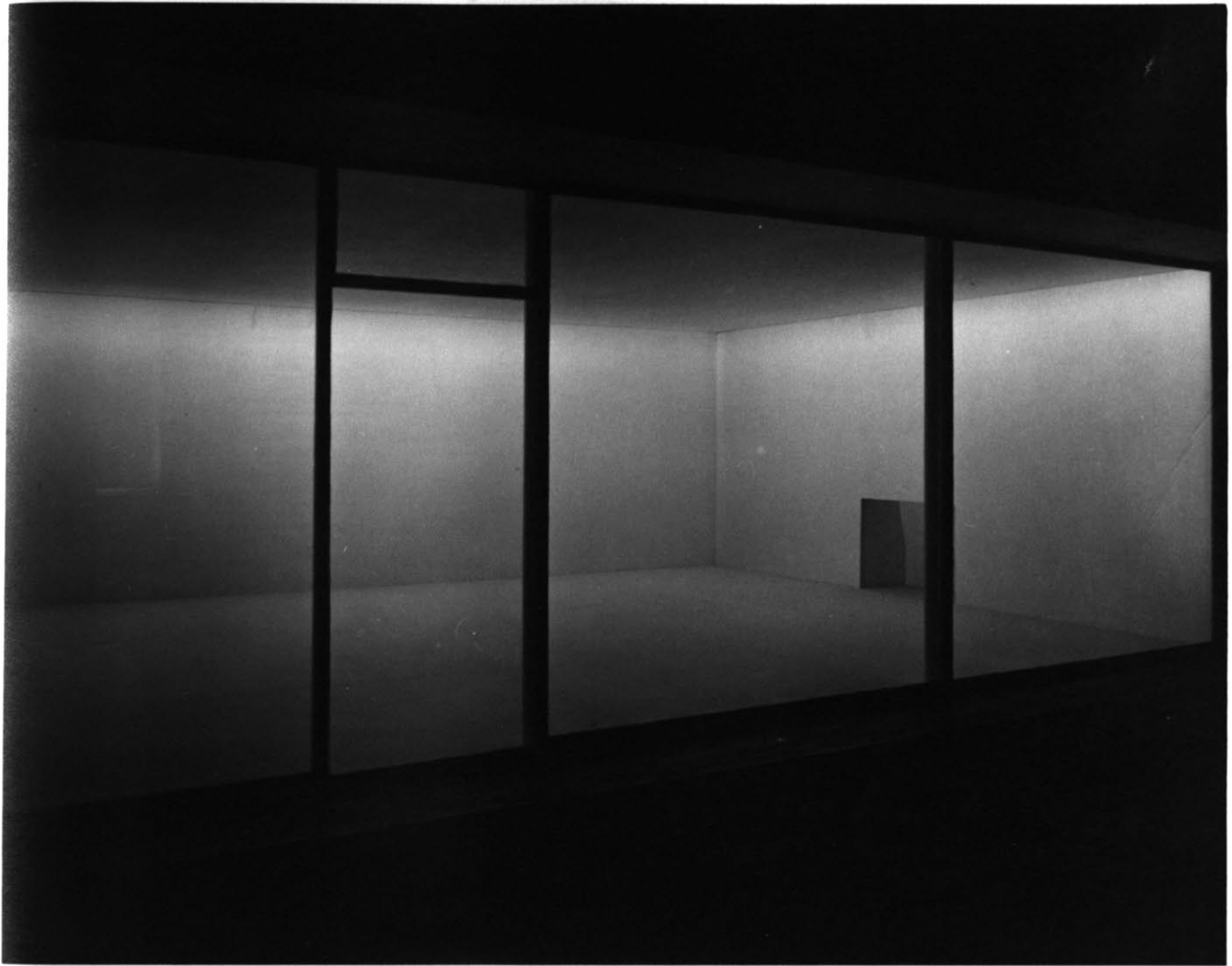

Gradation of light on walls from top to bottom - View 2

The ceiling seems suspended. Walls seem to be accented vertically.

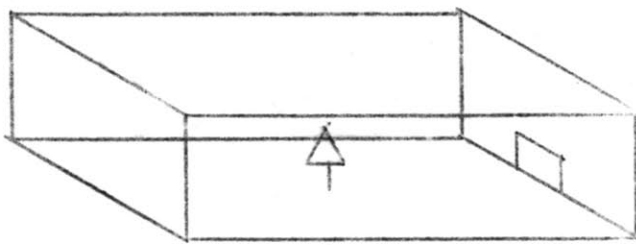
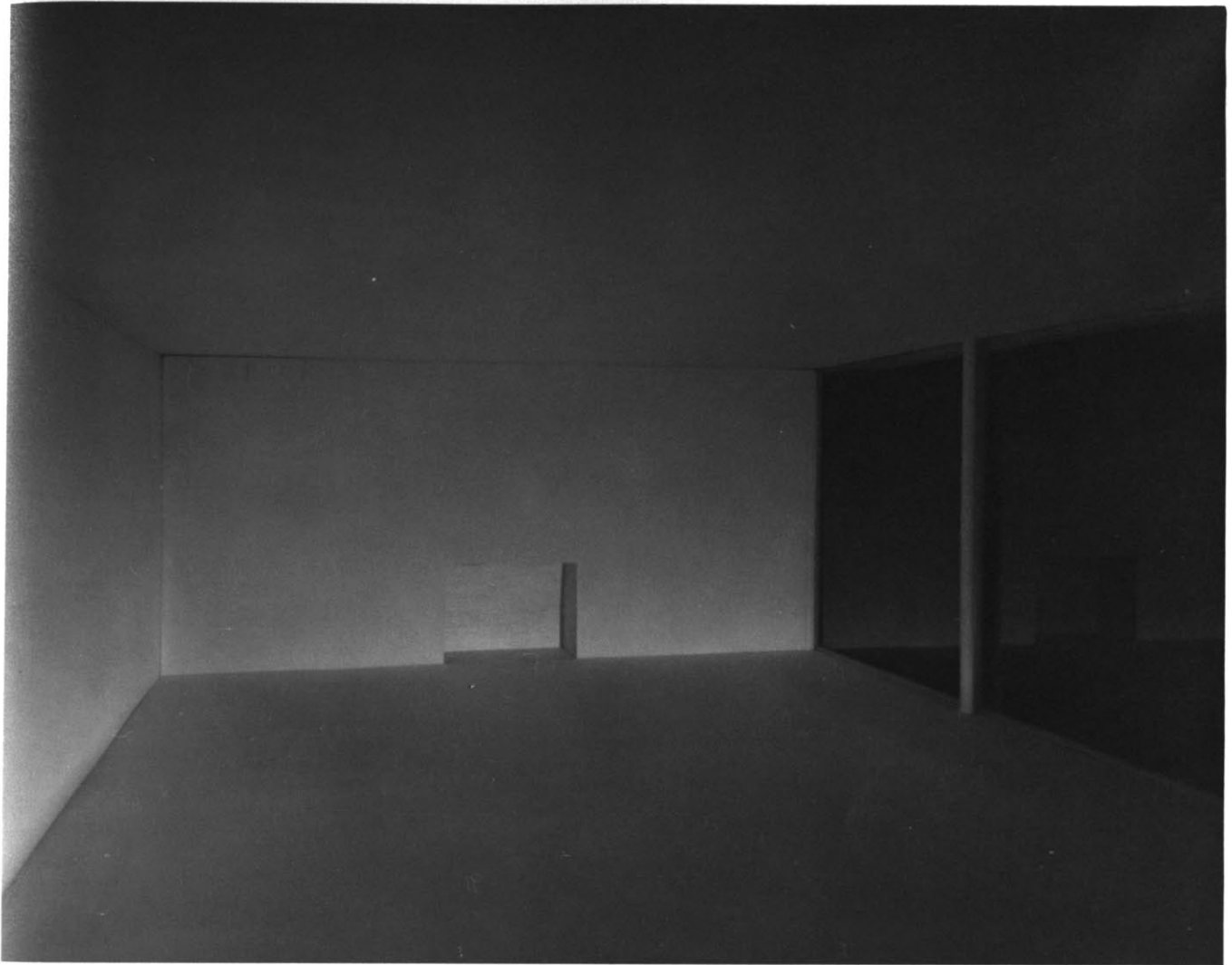

Gradation of light on walls from bottom to top - View 1

The floor seems to have a floating quality.

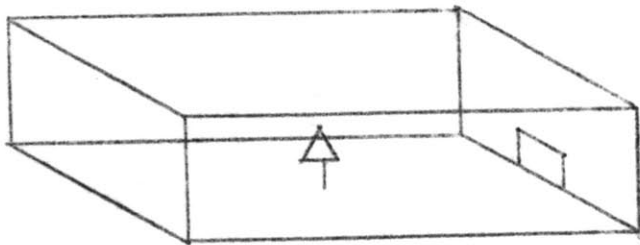
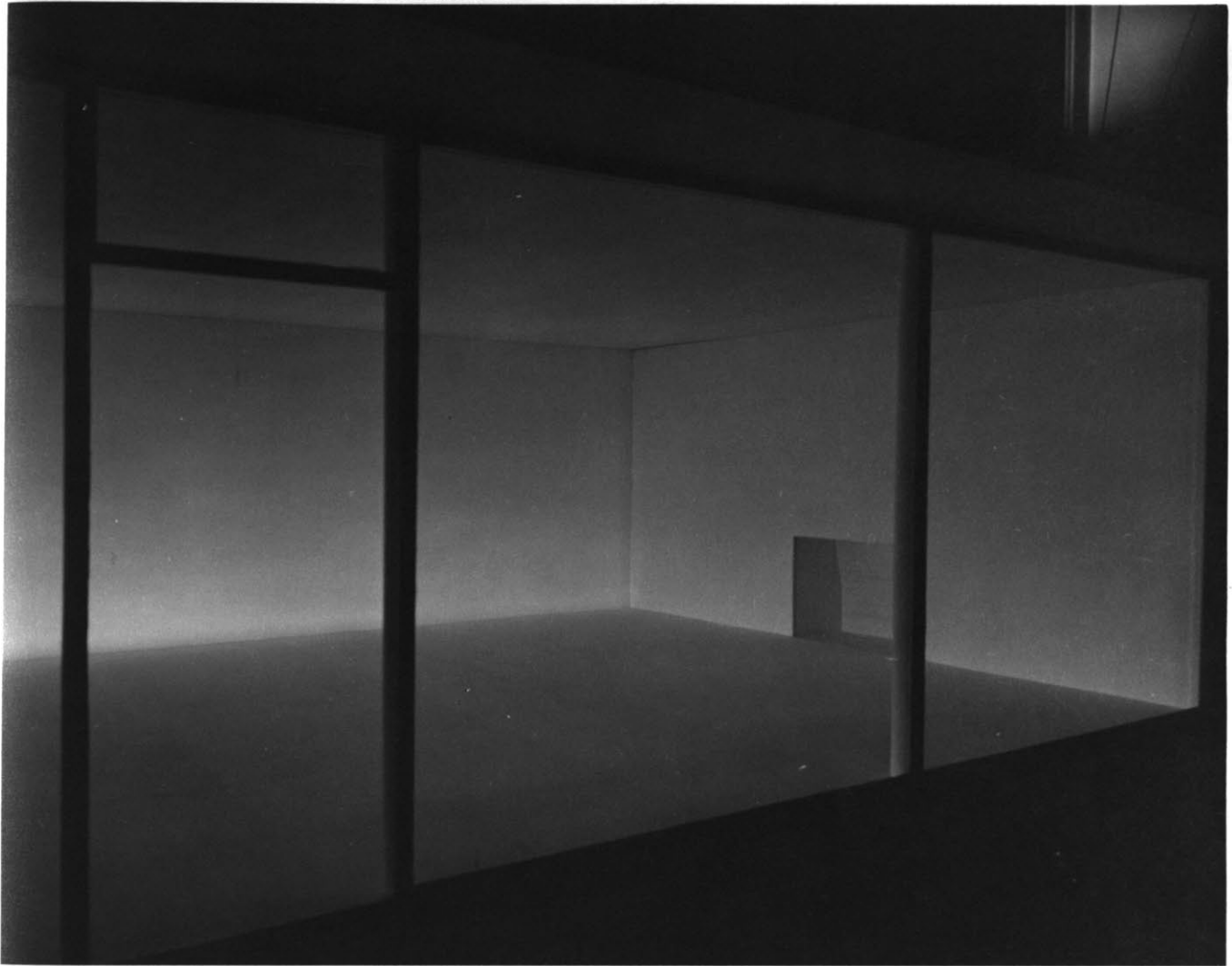

Gradation of light on walls from bottom to top - View 2

The floor seems to have a floating quality.

floor. The illusions of distortion of the entire space were not quite as obvious but the general feeling was that gradation from bright at the ceiling to dim at the floor tended to visually lower the ceiling while gradation from bright at the floor to dim at the ceiling tended to visually raise the ceiling.

Panels of light were projected along the cornice of the room. As seen on pages 32 and 33, to scale these panels would appear to be about one foot wide and of high intensity in contrast with the brightness of the remaining surfaces. A distinct feeling that the ceiling was detached or floating was observed. From some viewpoints the intense panel of light tended to accent the horizontal dimensions of the space. With the panels of light still projected, additional light was directed at the ceiling, as illustrated on pages 34 and 35. The observations here indicated that the feeling of suspension of the ceiling decreased, the accent of horizontal dimensions ceased and the room seemed to be expanded vertically.

Pages 36, 37, 38 and 39 show an example of an illusory effect influenced by irradiation. This was produced when an ellipse of light was projected on the ceiling. In the first case tried this ellipse of light was the only light source in the room. In this case the ellipse seemed to advance and to give the appearance of a luminous panel suspended from the ceiling. Later, light was added to the walls and the ellipse seemed to recede. In the second example a feeling of expansion in the horizontal direction was observed

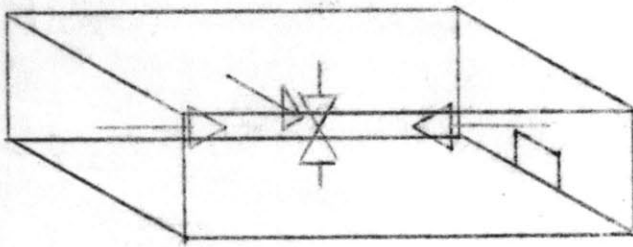
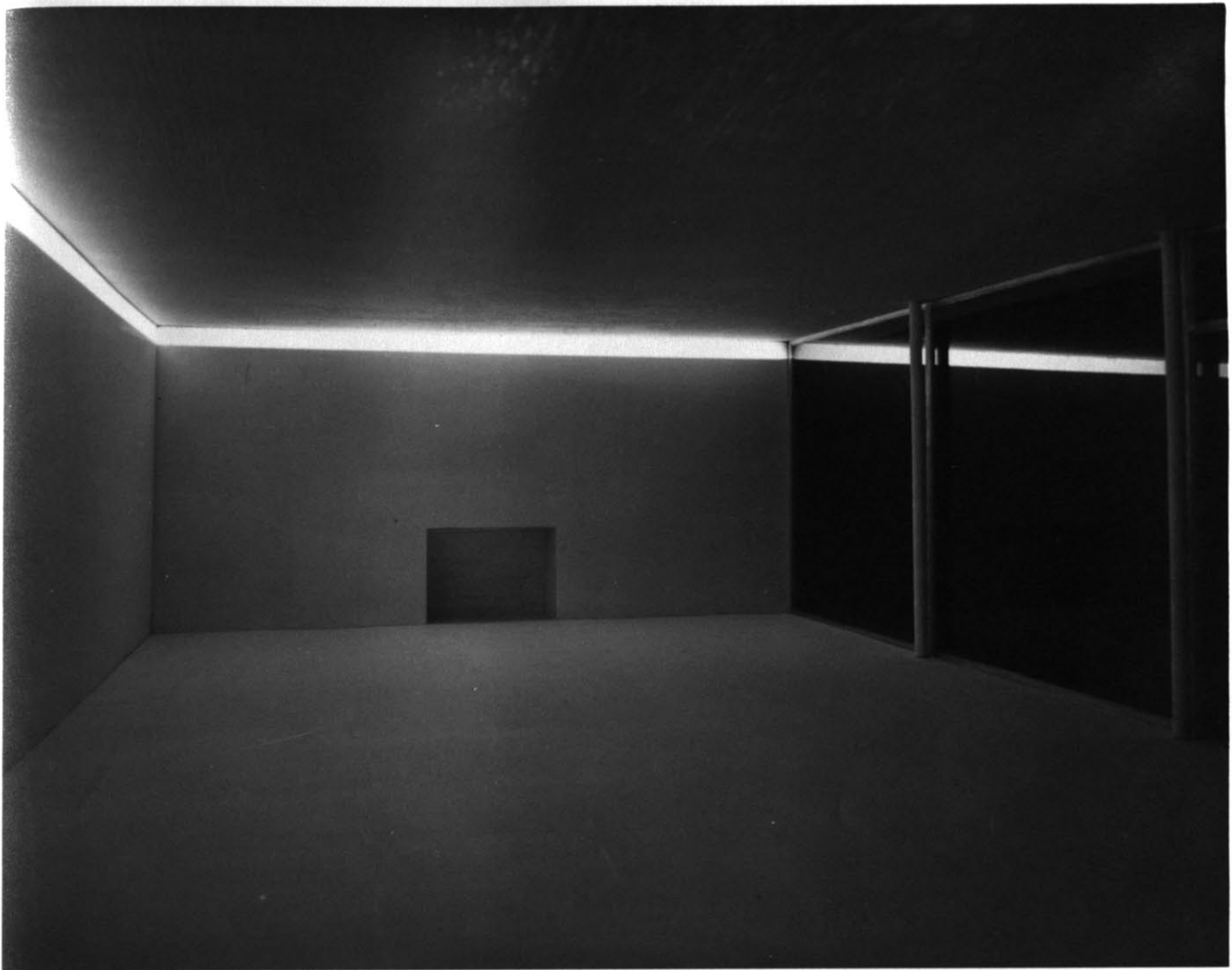

Panel of light at cornice - View 1

Ceiling seems suspended. Room seems compressed.

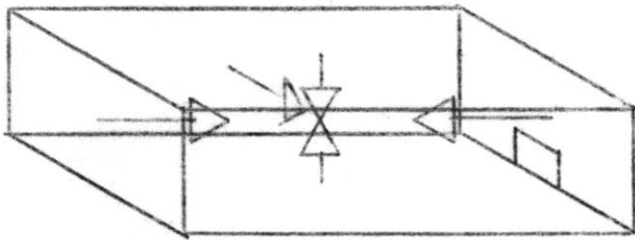
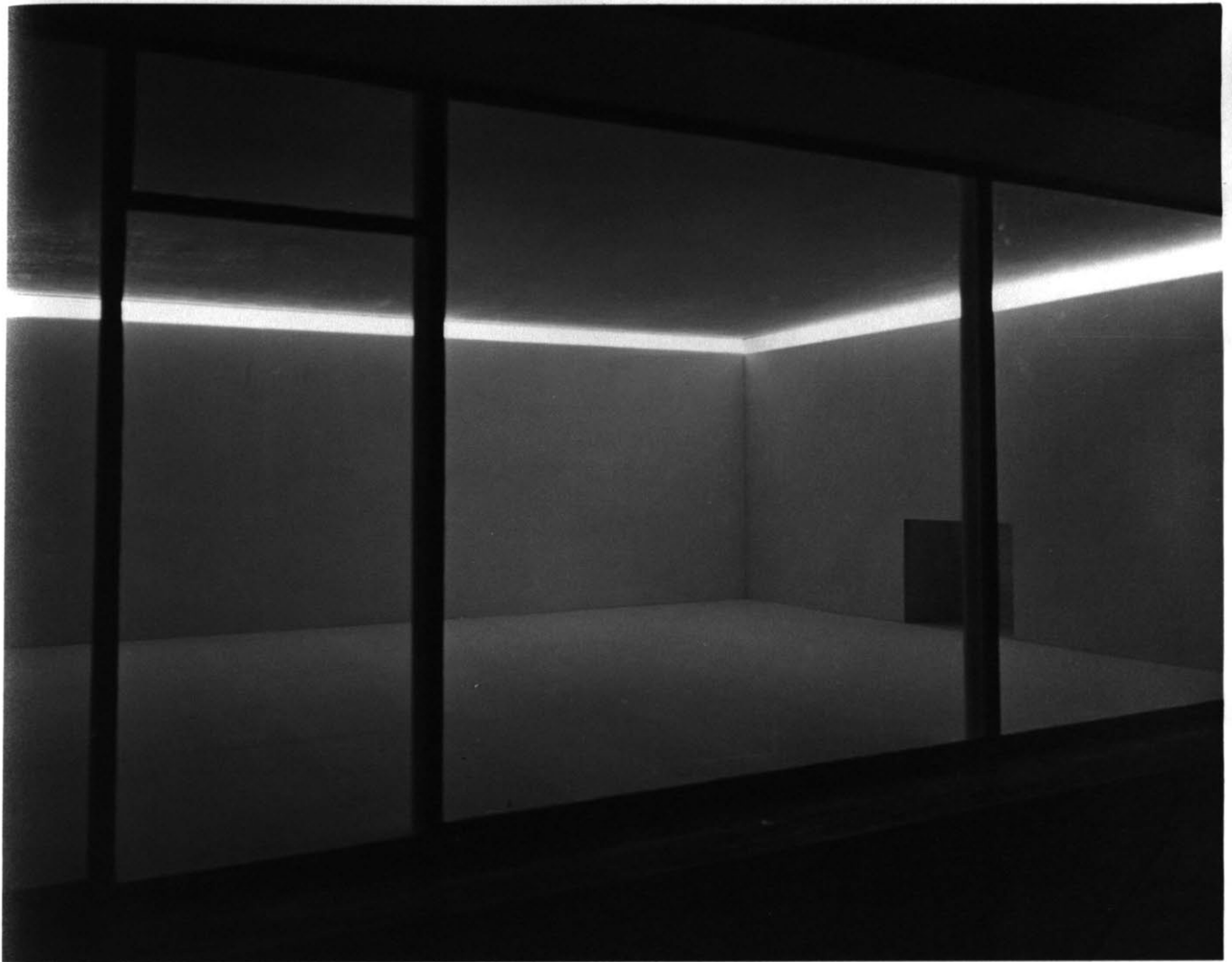

Panel of light at cornice - View 2

Ceiling seems suspended. Panel of light seems to extend room horizontally.

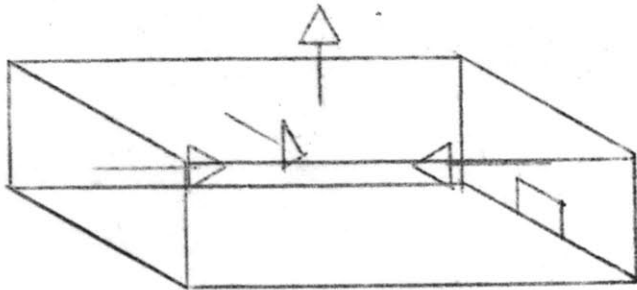
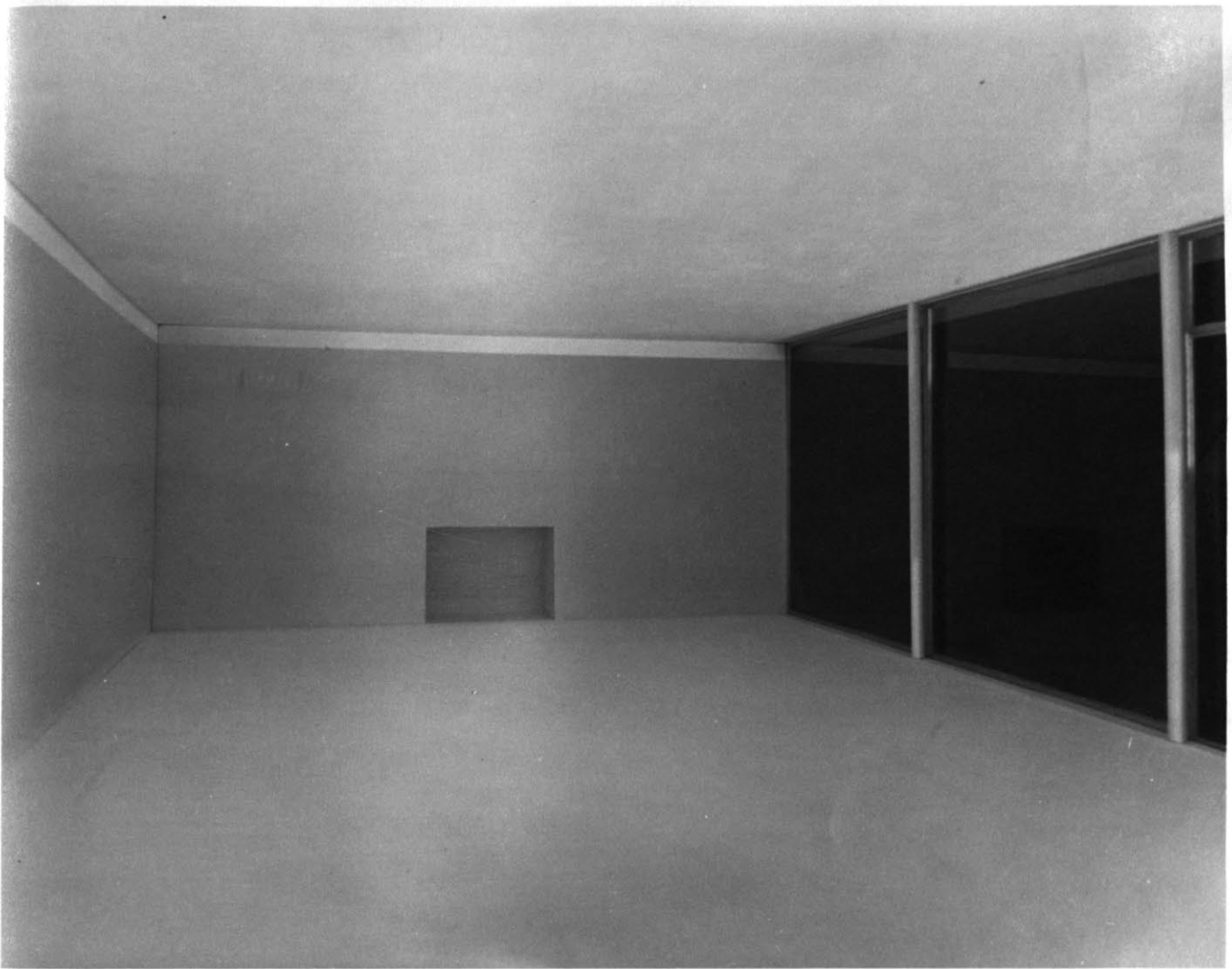

Ceiling lighted and panel of light at cornice - View 1

Room seems expanded vertically.

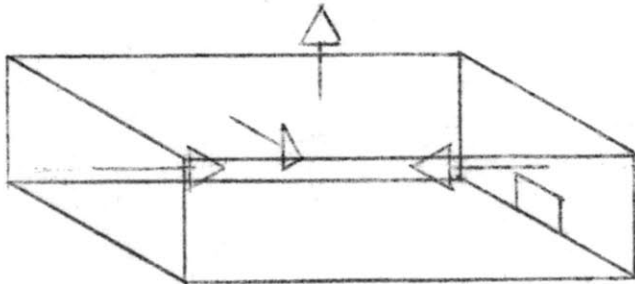
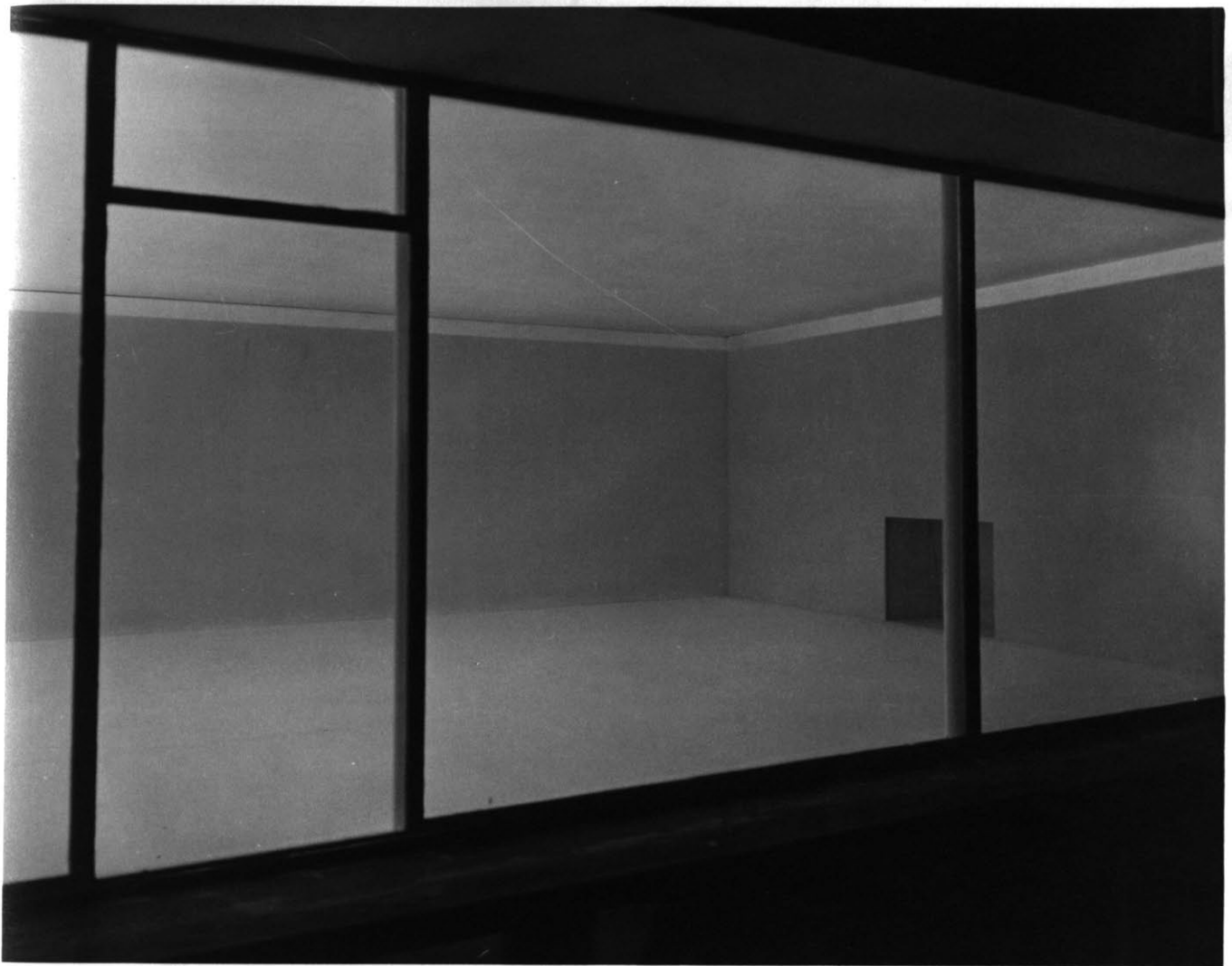

Ceiling lighted and panel of light at cornice - View 2

Room seems expanded vertically.

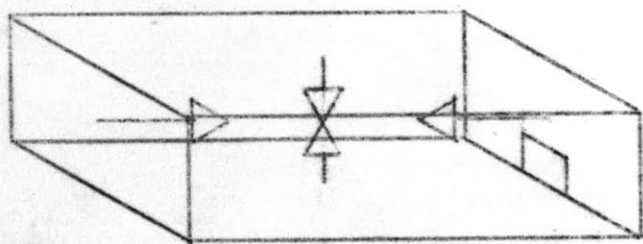
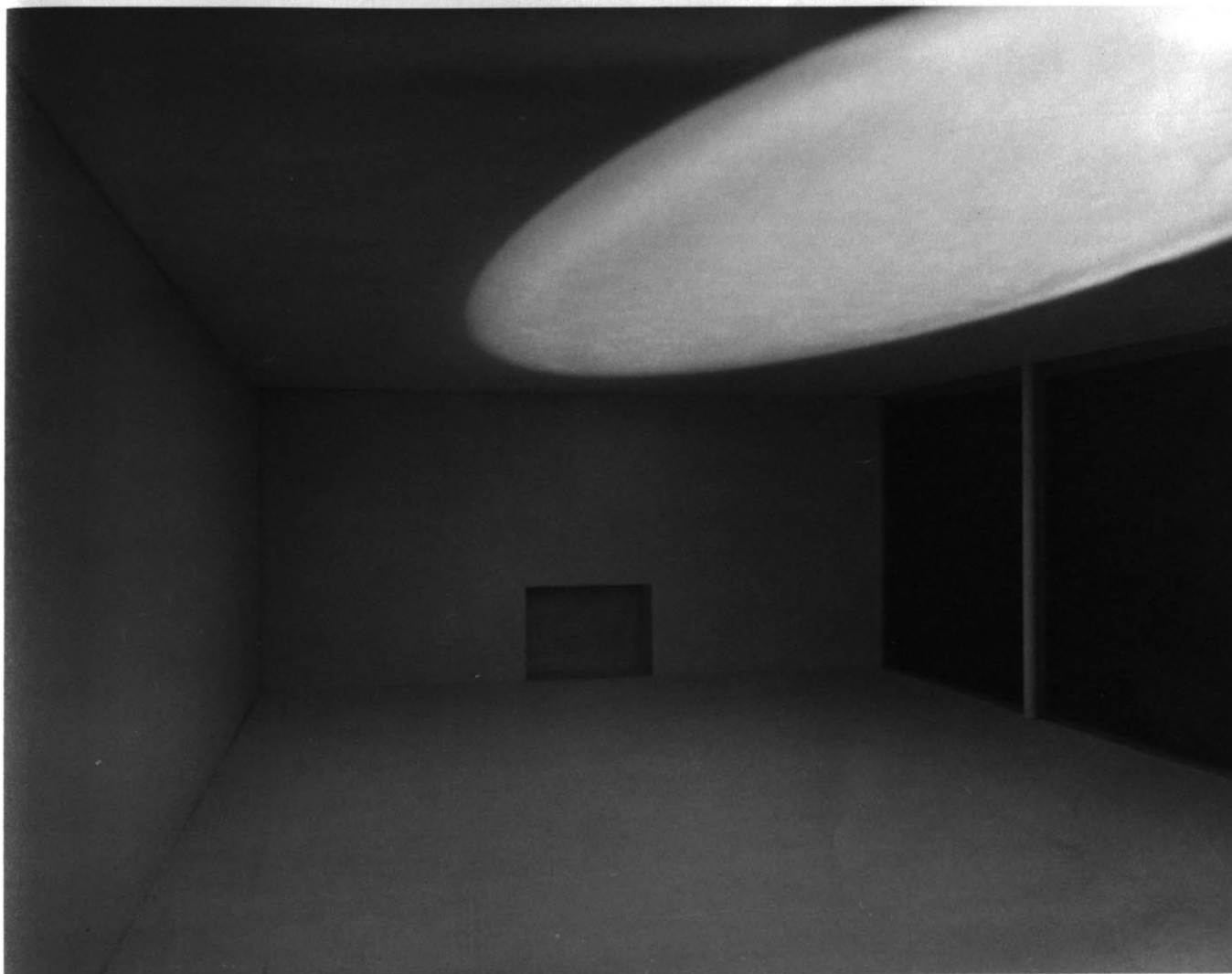

Oval ceiling light - View 1

Oval light seems to be lower than the ceiling.

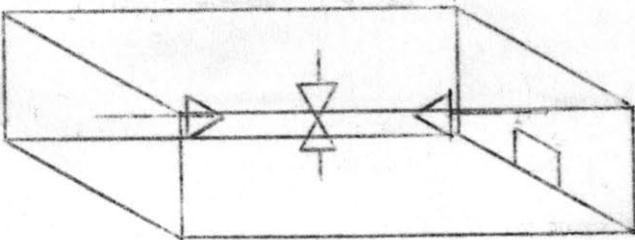
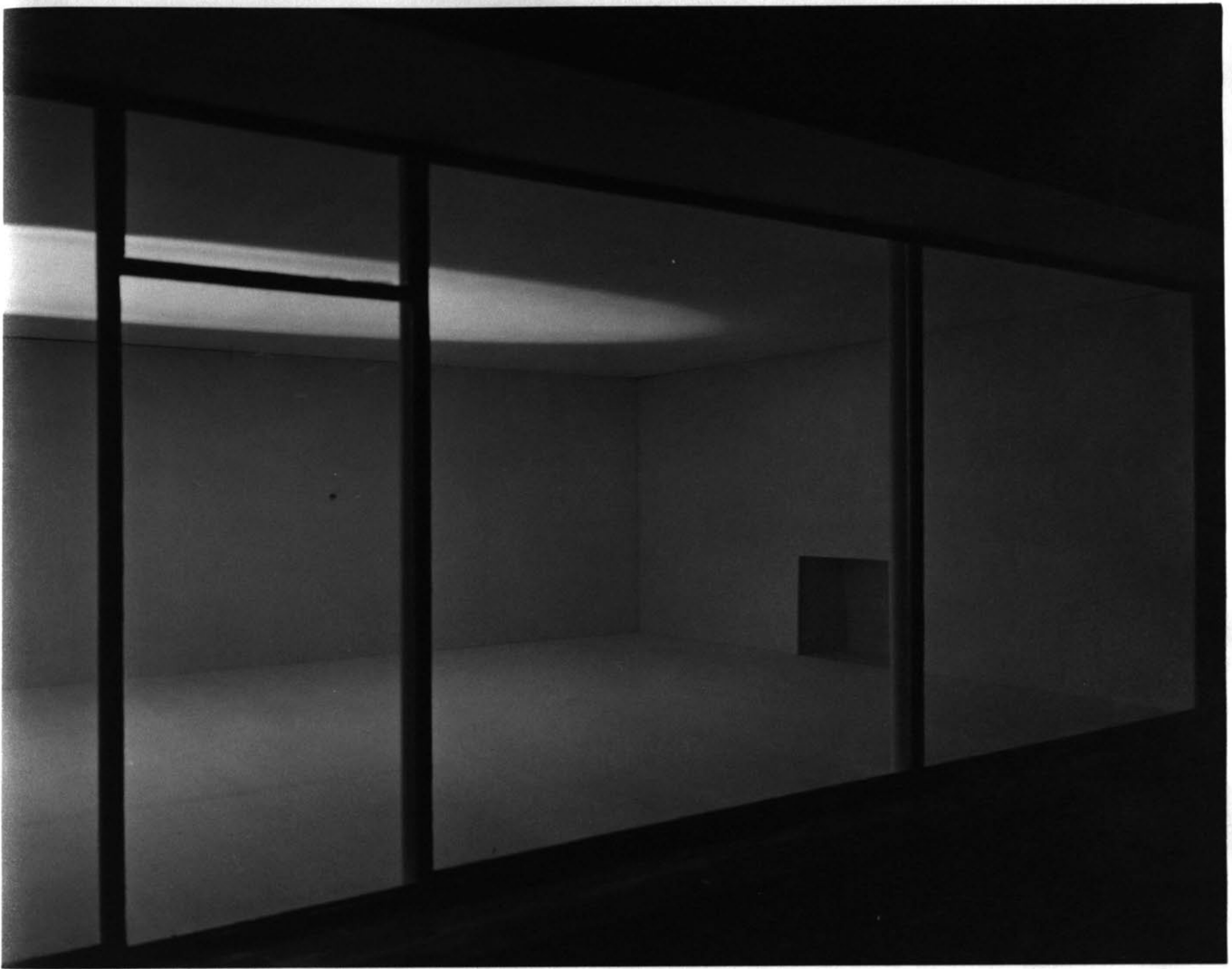

Oval ceiling light - View 2

Oval light seems to be lower than the ceiling.

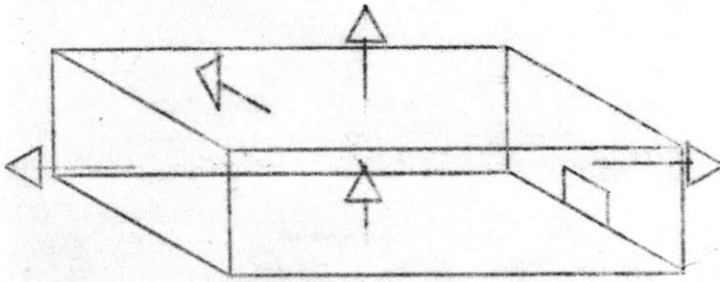
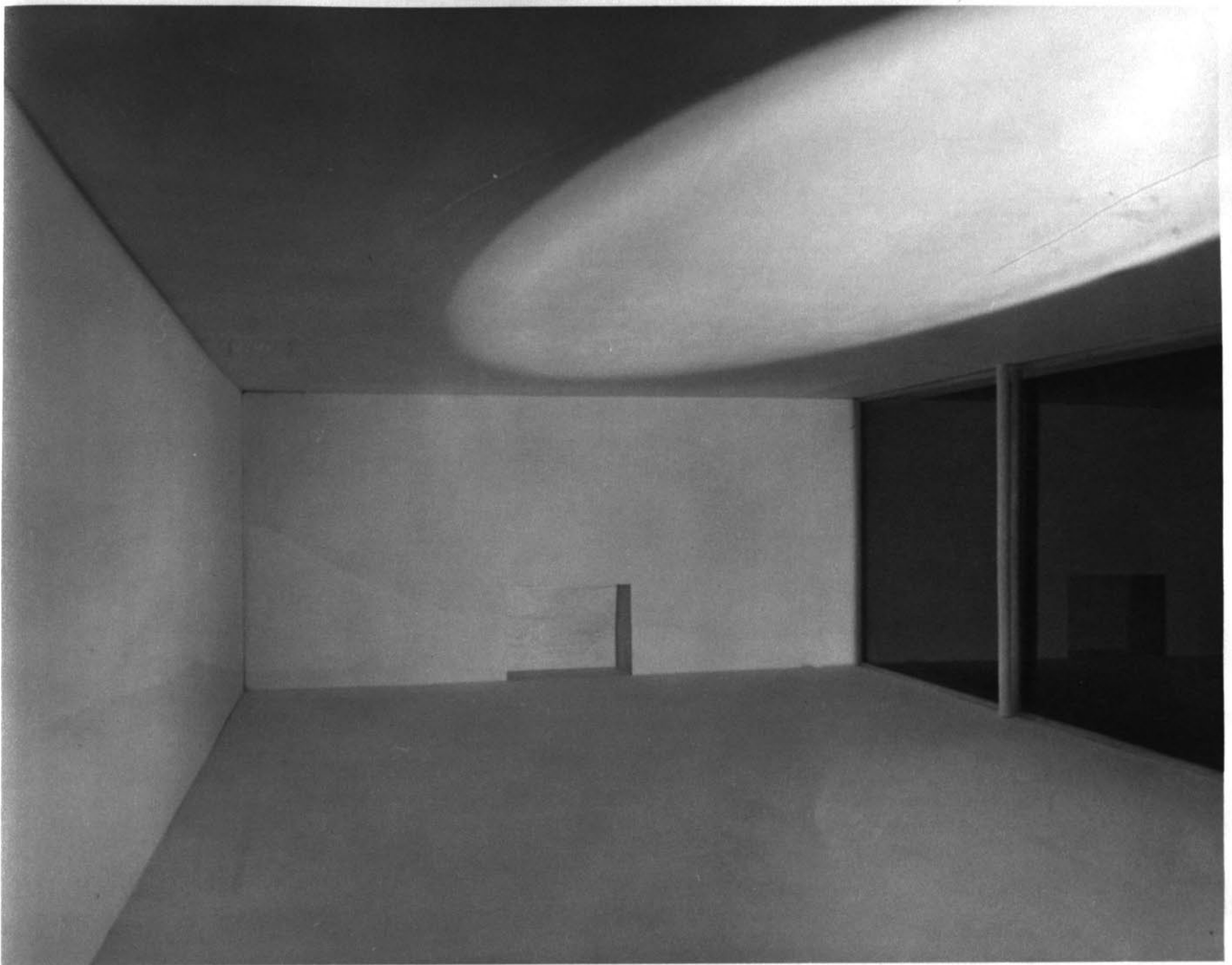

Walls lighted and oval ceiling light - View 1

Oval ceiling light seems to rise. There is a horizontal extension of the room due to the lighted walls.

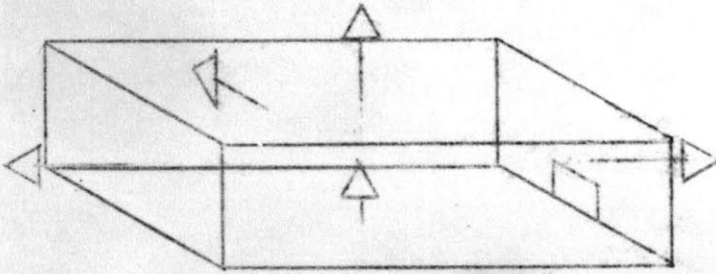
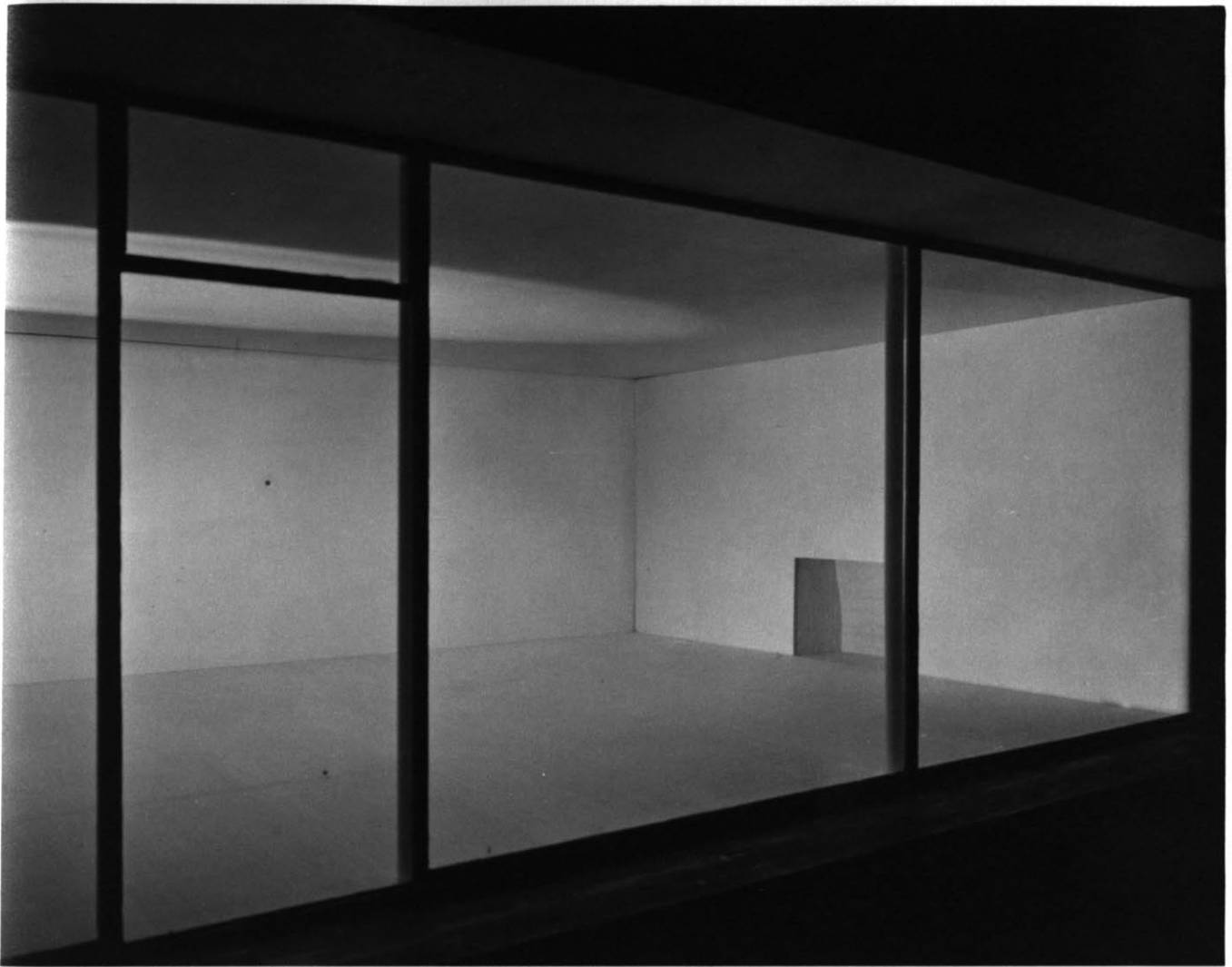

Walls lighted and oval ceiling light - View 2

Oval ceiling light seems to rise. There is a horizontal extension of the room due to the lighted walls.

and also a feeling of expansion in the vertical direction of the space bounded by the elliptical light. The addition of light to the walls not only seemed to nullify the original feeling but to reverse it.

Attempts were made to introduce light in the form of linear patterns as an aid in the distortion of space. Light of high intensity was projected on the walls while the general level of illumination was kept up to that necessary for average living. These projected patterns and designs were used as a means of reproducing various linear and geometric illusions discussed earlier.

To achieve several distortive effects common to mirrors, transparent specular reflecting surfaces were superimposed over existing wall panels. In the cases illustrated on pages 41 through 45, the location of the light source was changed. In the case illustrated on pages 46, 47, and 48, the position of the light source remained fixed but the direction of projection of light was changed.

Color was introduced independently as a means of distorting visual space and was also used as a reinforcement to other illusions. Some of the colors, the yellows, oranges, and reds appeared to be advancing. Blues and greens appeared to be receding. A wall treated with a cool color tends to recede and expand a space, while a wall treated with a warm color tends to advance and contract a space. Combinations of warm and cool colors tend to give a wall a visual effect of curvature or irregularity. Combinations of colors were introduced in combination with controlled gradation and the

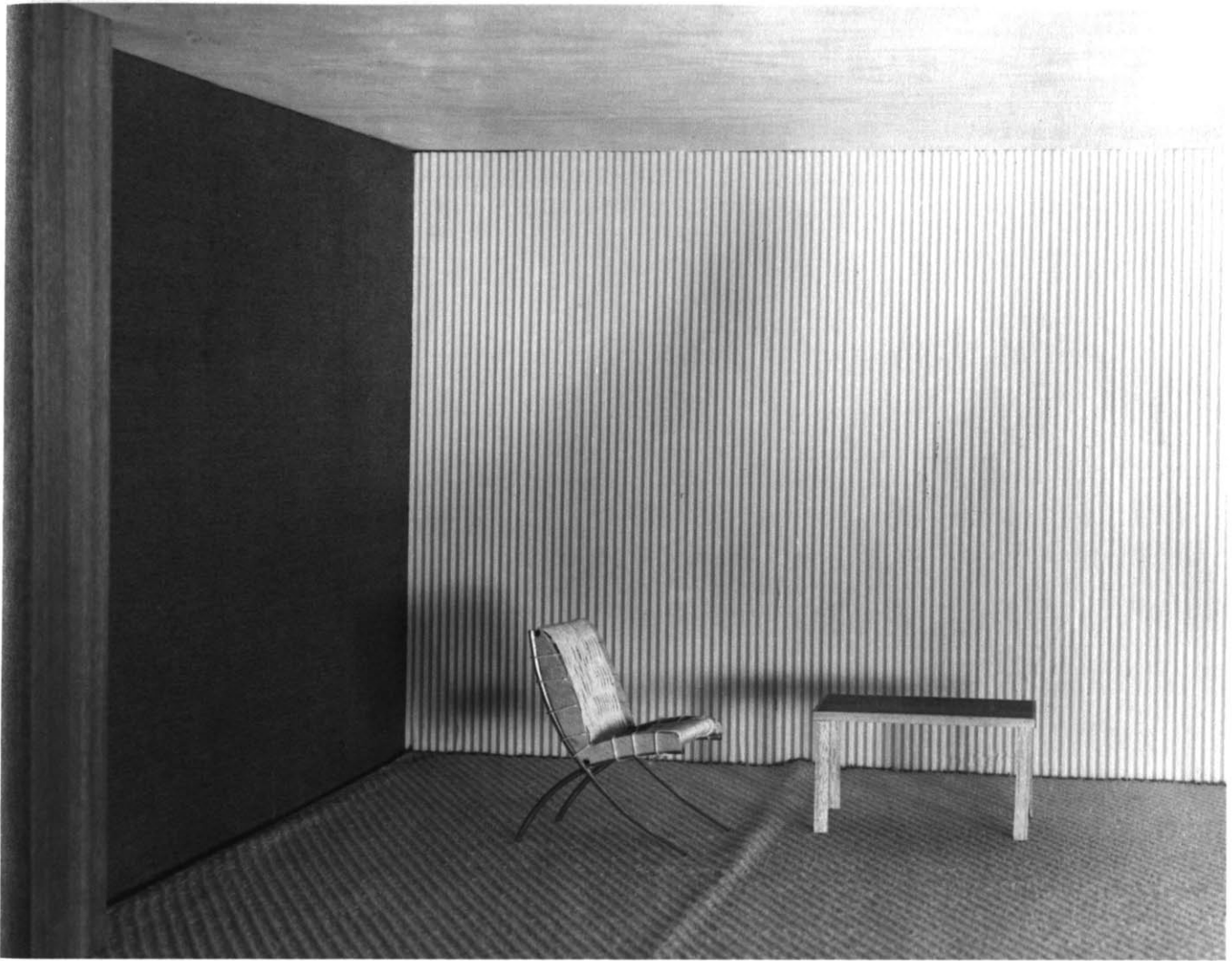

Flat lighting

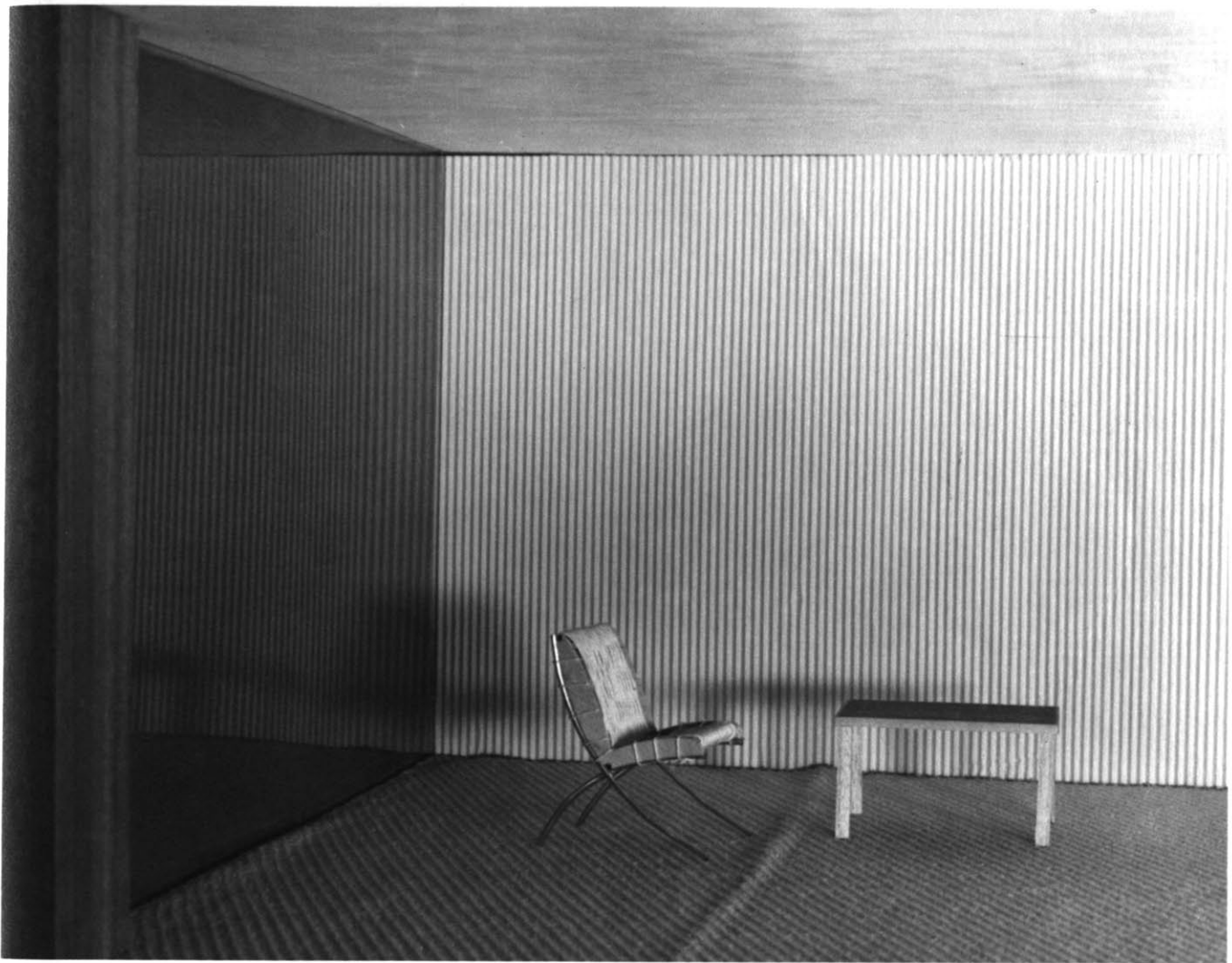

Flat lighting

Plastic panel over left wall

Mirroring illusion of extension.



Light tangential in horizontal direction

The back wall assumes the quality of tapestry.

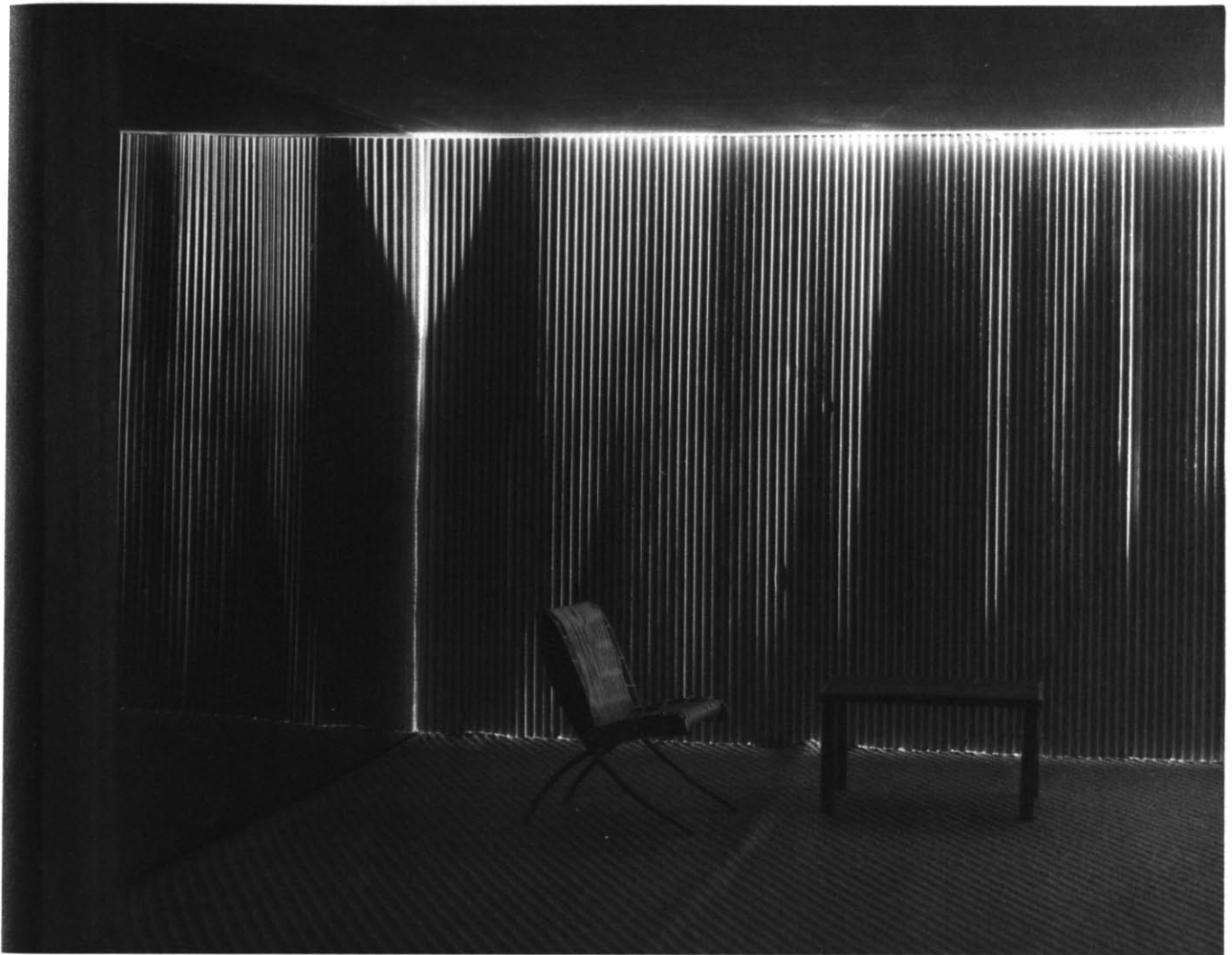

Light tangential in horizontal direction

Mirroring illusion of extension.



Light tangential in vertical direction

Interrupted extent tends to heighten room.

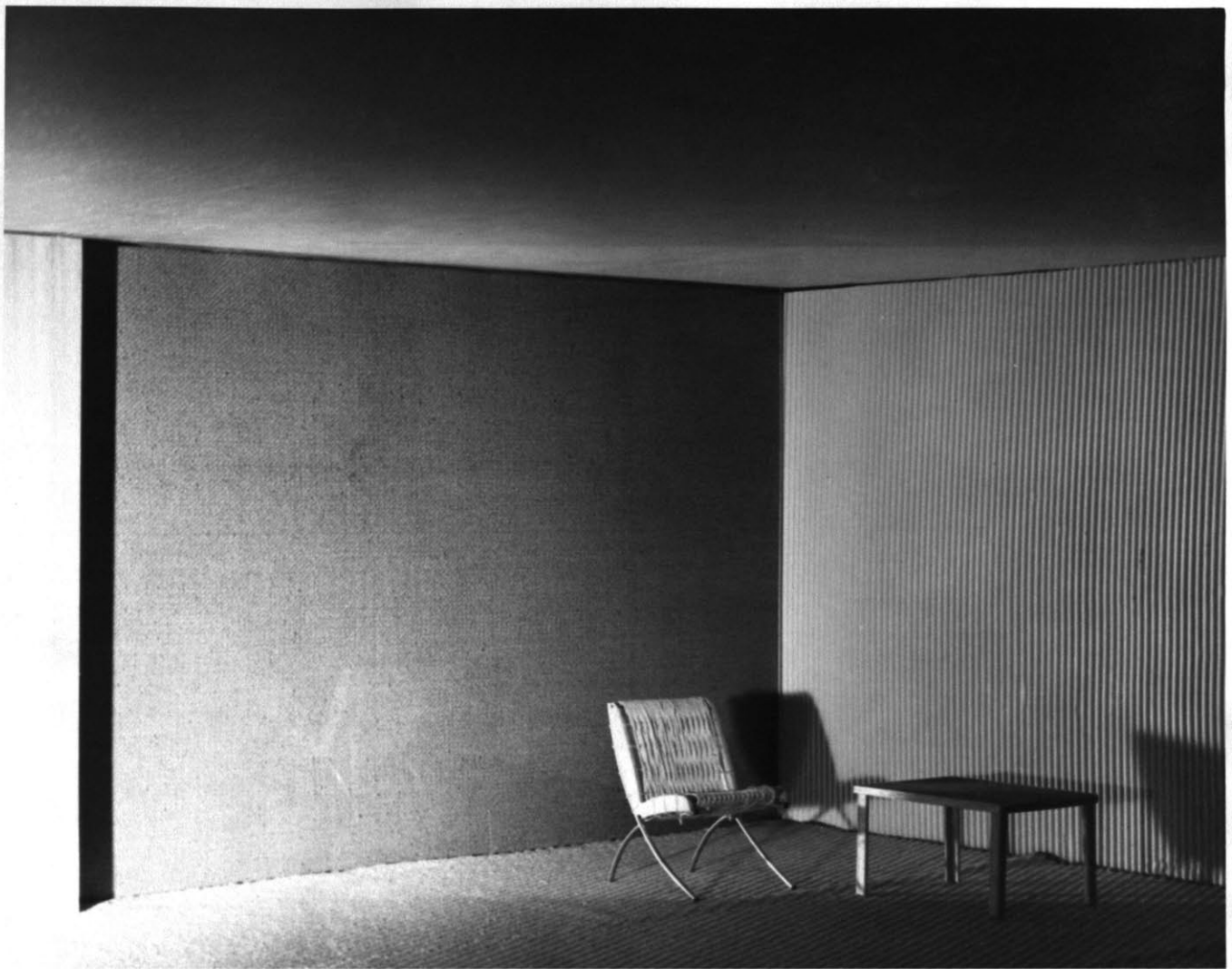

Light source 0

In this and the following two photographs one light source of constant intensity has been used. The illusion of spatial distortion has been achieved by rotating the light source through 90 .

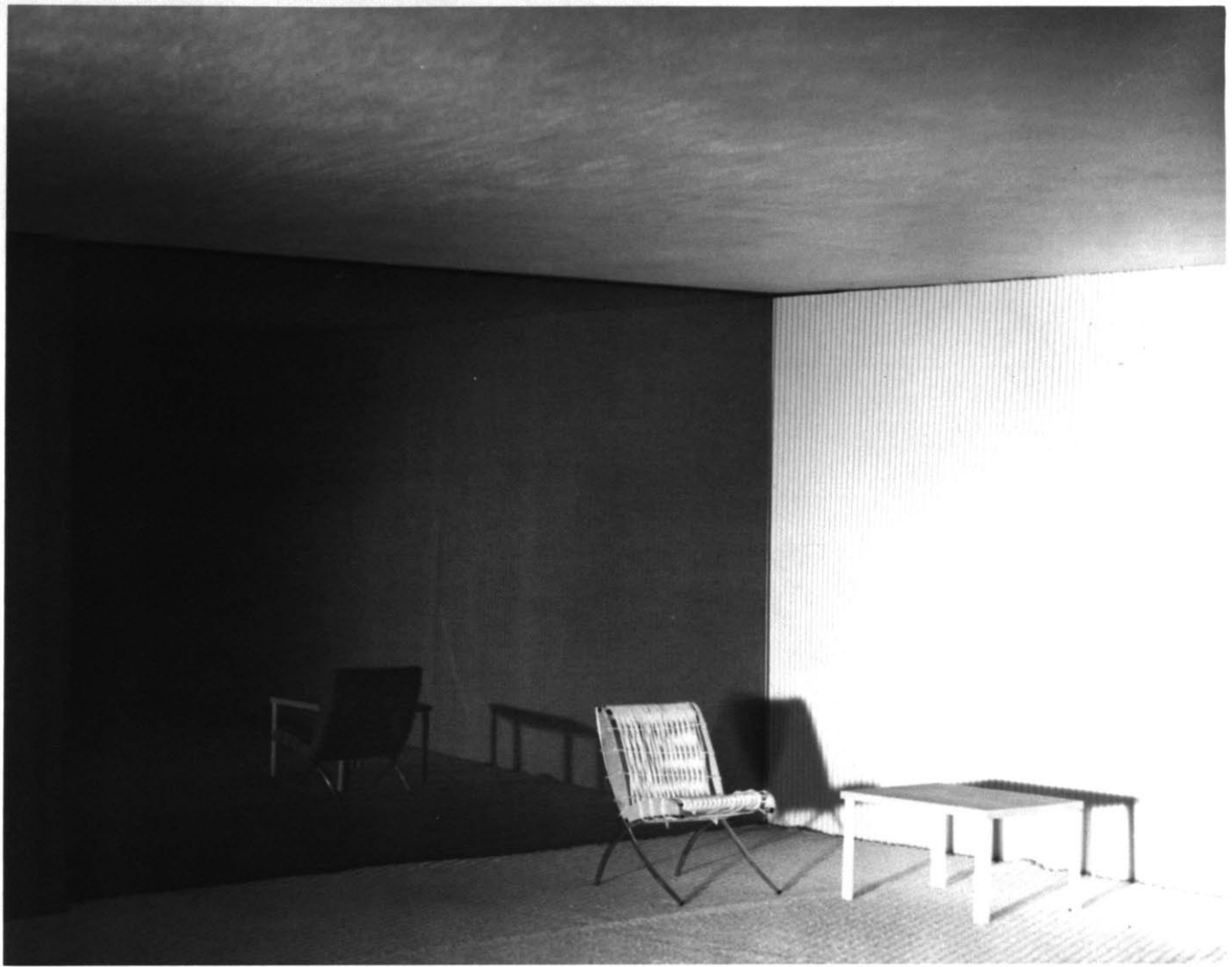

Light source 45

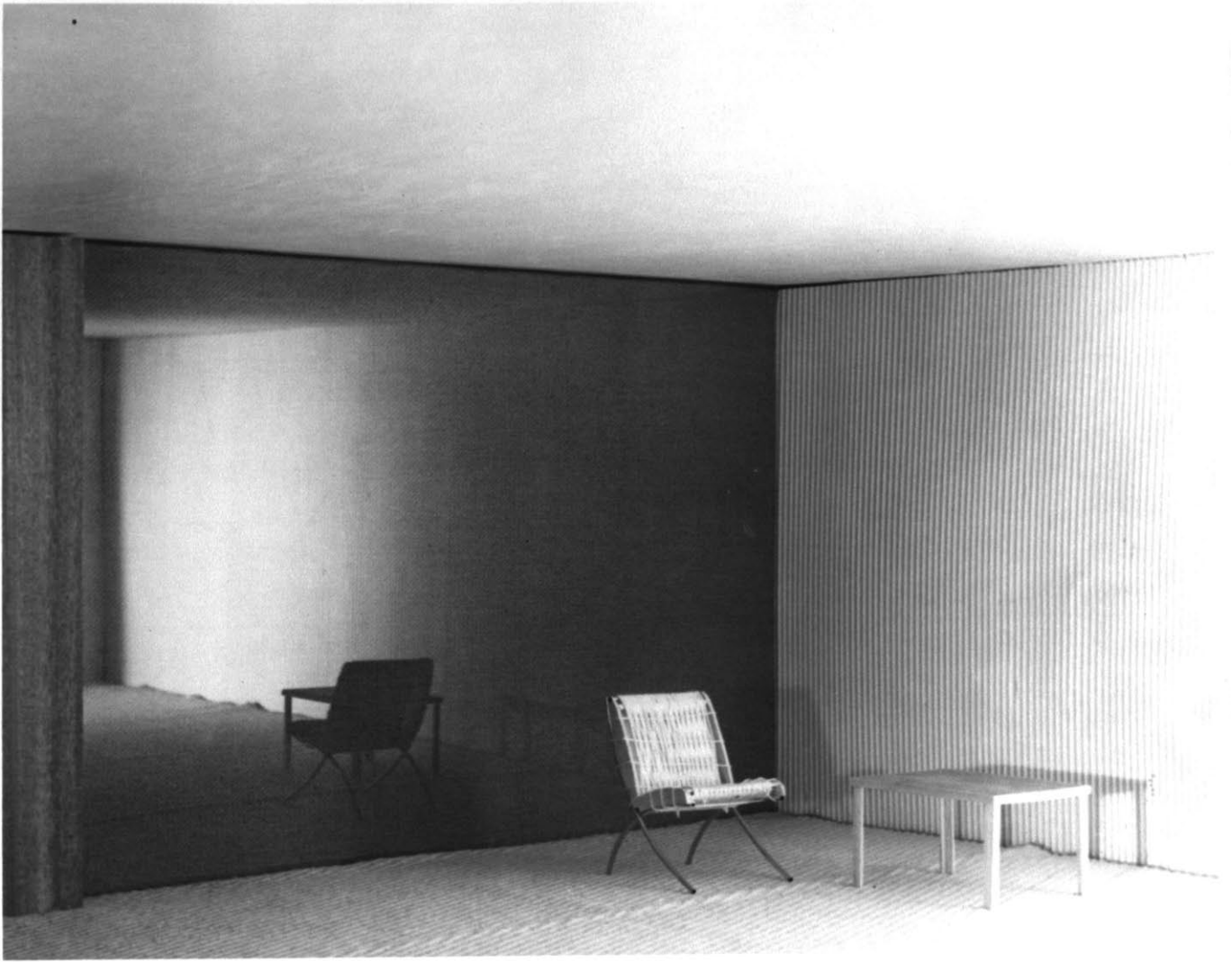

Light source 90

result was that the visual experience of curvature was amplified. In this manner flat walls may be visually curved and curved walls may be visually flattened.

TEXTURE

The type and degree of texture of a surface are important elements in the experience of light reflection. The plasticity of an object may be revealed by the use of brightness contrast, light and shade, and the highlights and shadows. Light was used to give relief and solidity to surfaces and to bring out their three-dimensional features compatible with the effects desired. Panels were treated with various textures and were lighted under conditions of tangential and flat lighting. By controlling the light source a vertical texture, horizontal texture or absence of texture could be obtained. In this way some of the more common geometric illusions were reproduced. It was also found that the degree of modeling achieved with light had a bearing on the apparent position of the surface. Surfaces lighted with flat light tended to recede while surfaces lighted with tangential light tended to advance. These examples are illustrated on pages 50 through 62.

ACCENTS OF LIGHT

Accents of light form an important component of the design of a light space. A general overall diffuse light of proper brightness could satisfy the physiological conditions necessary for a

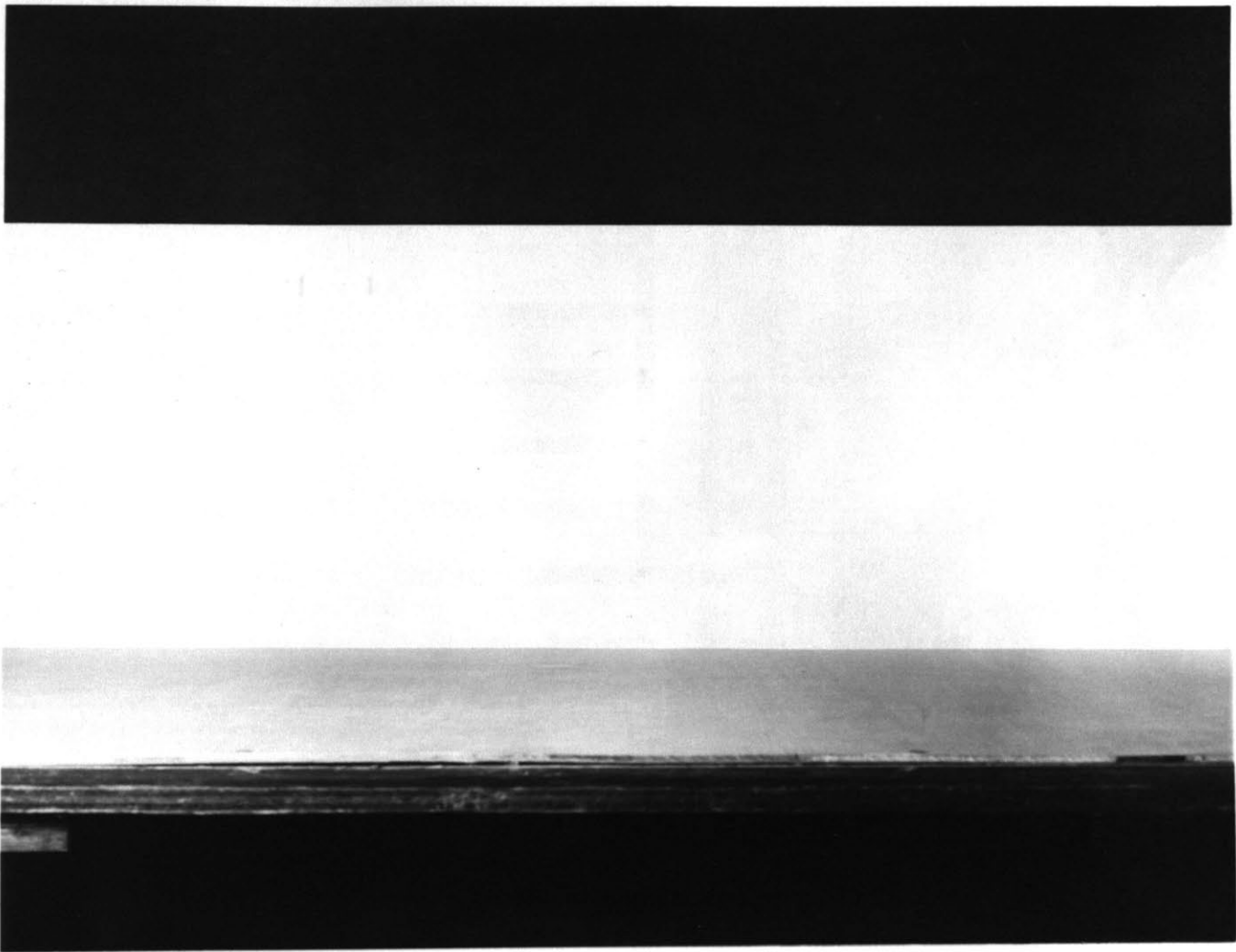

Varied texture

Flat light

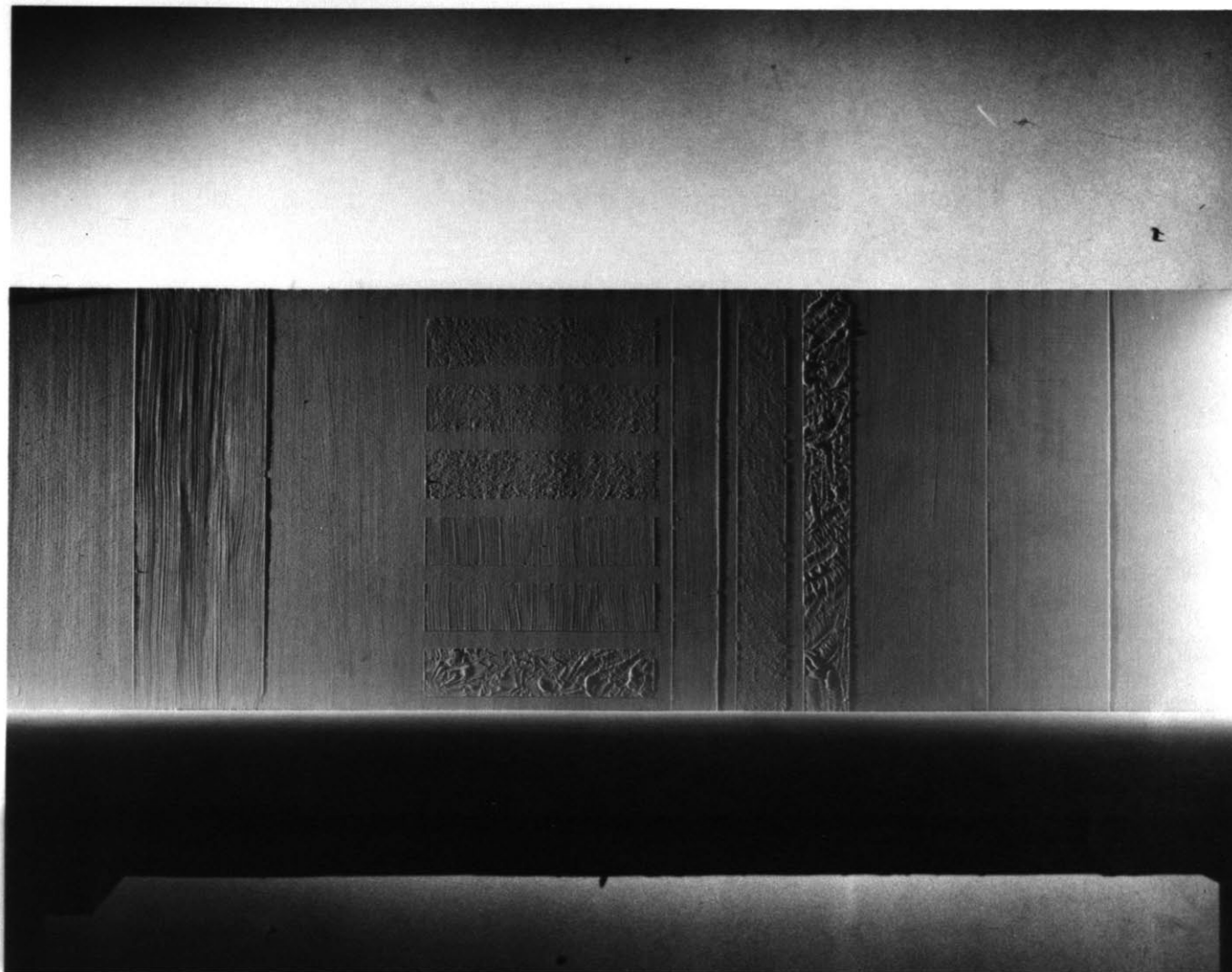

Varied texture

Light tangential in horizontal direction.

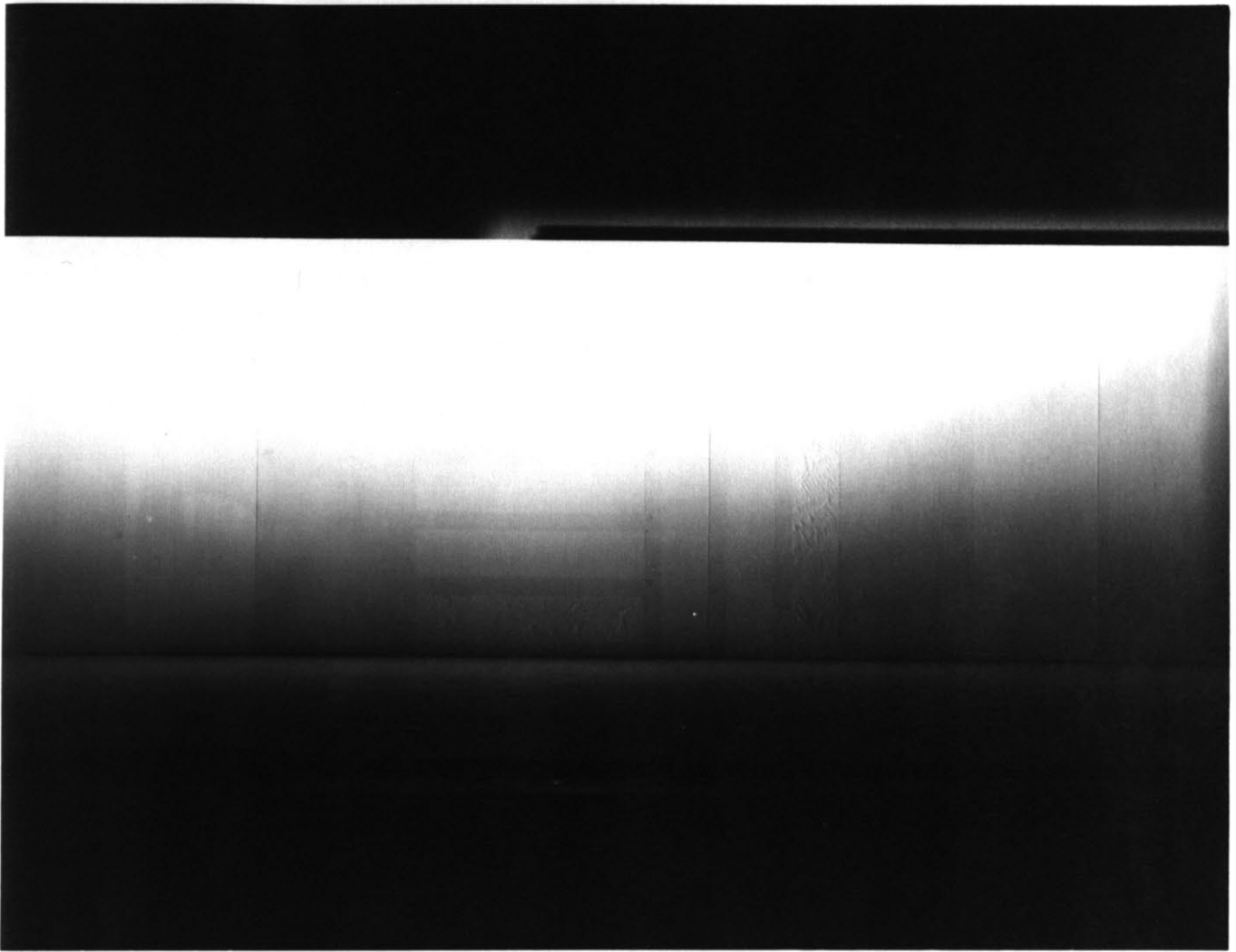

Varied texture

Graded light

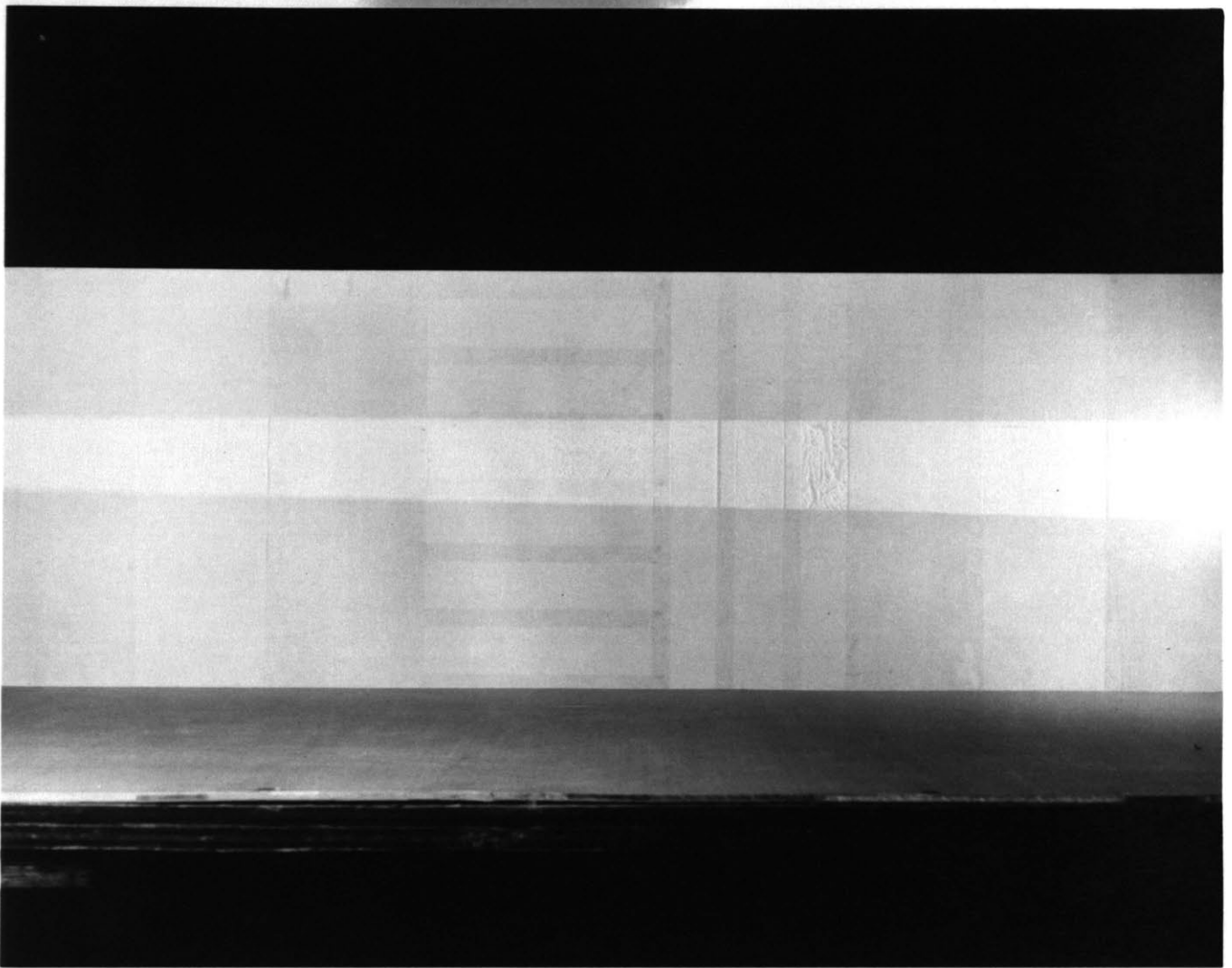

Varied texture
Accent of light

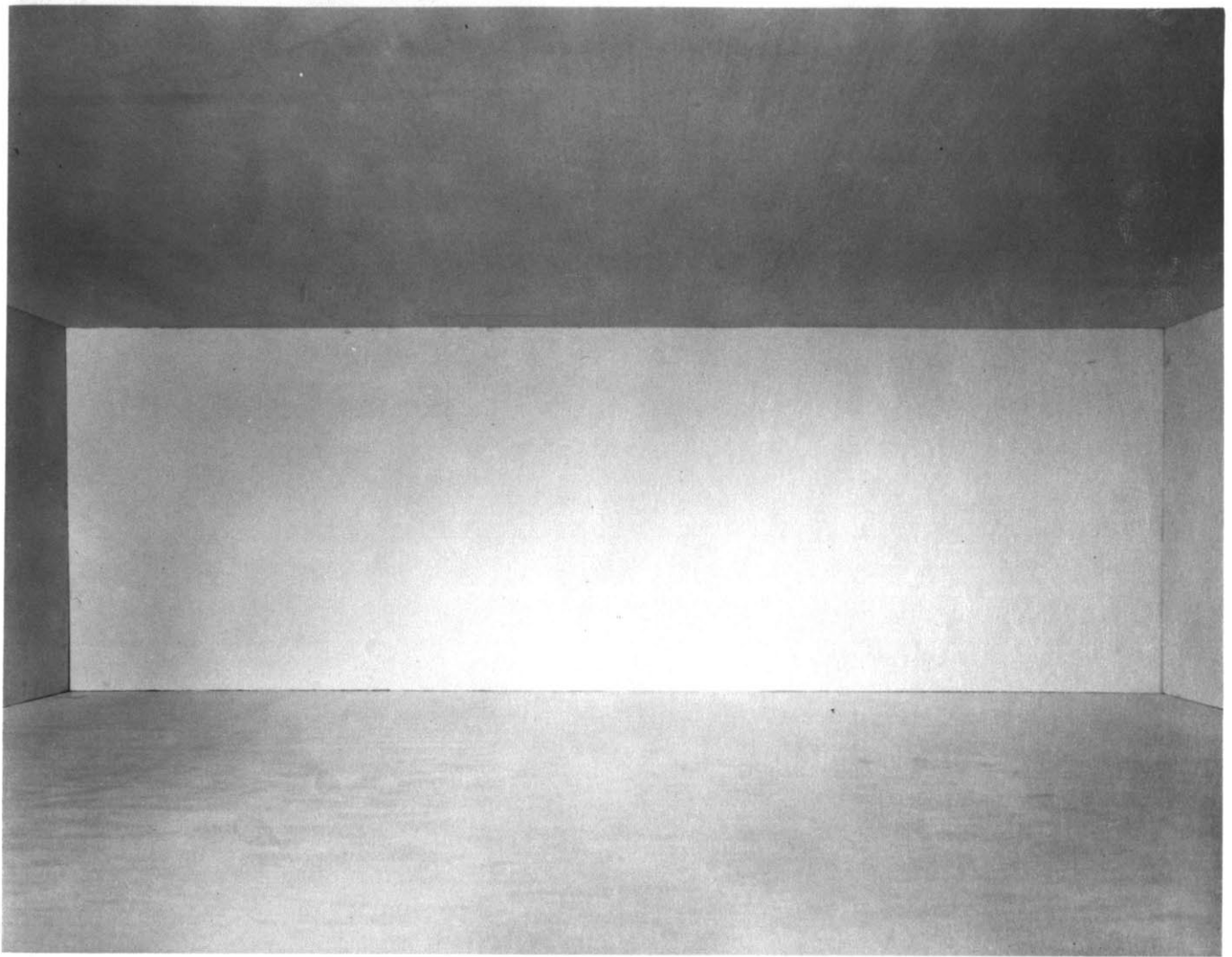

Vertical and horizontal texture

Flat light

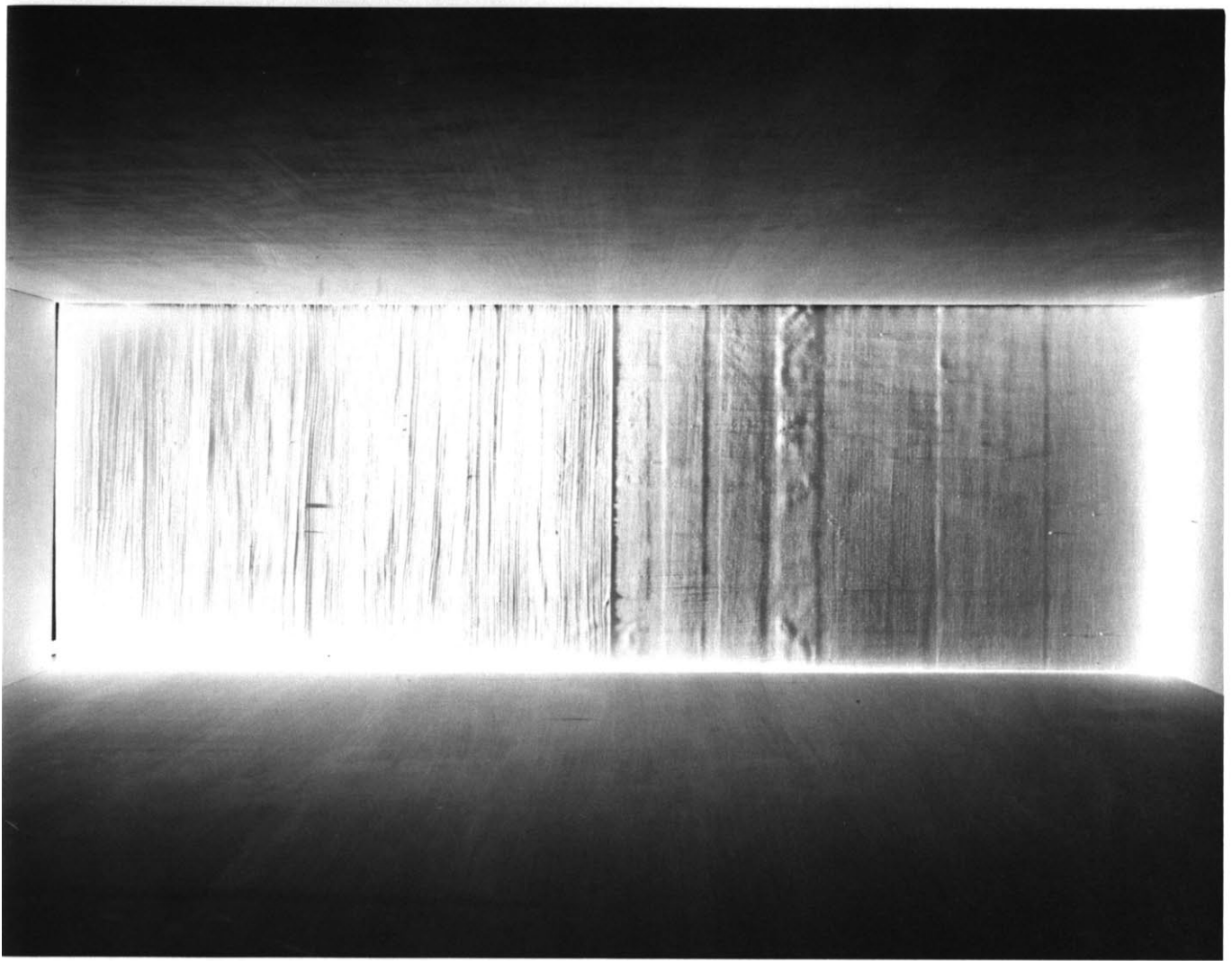

Vertical and horizontal texture
Light tangential in horizontal direction.

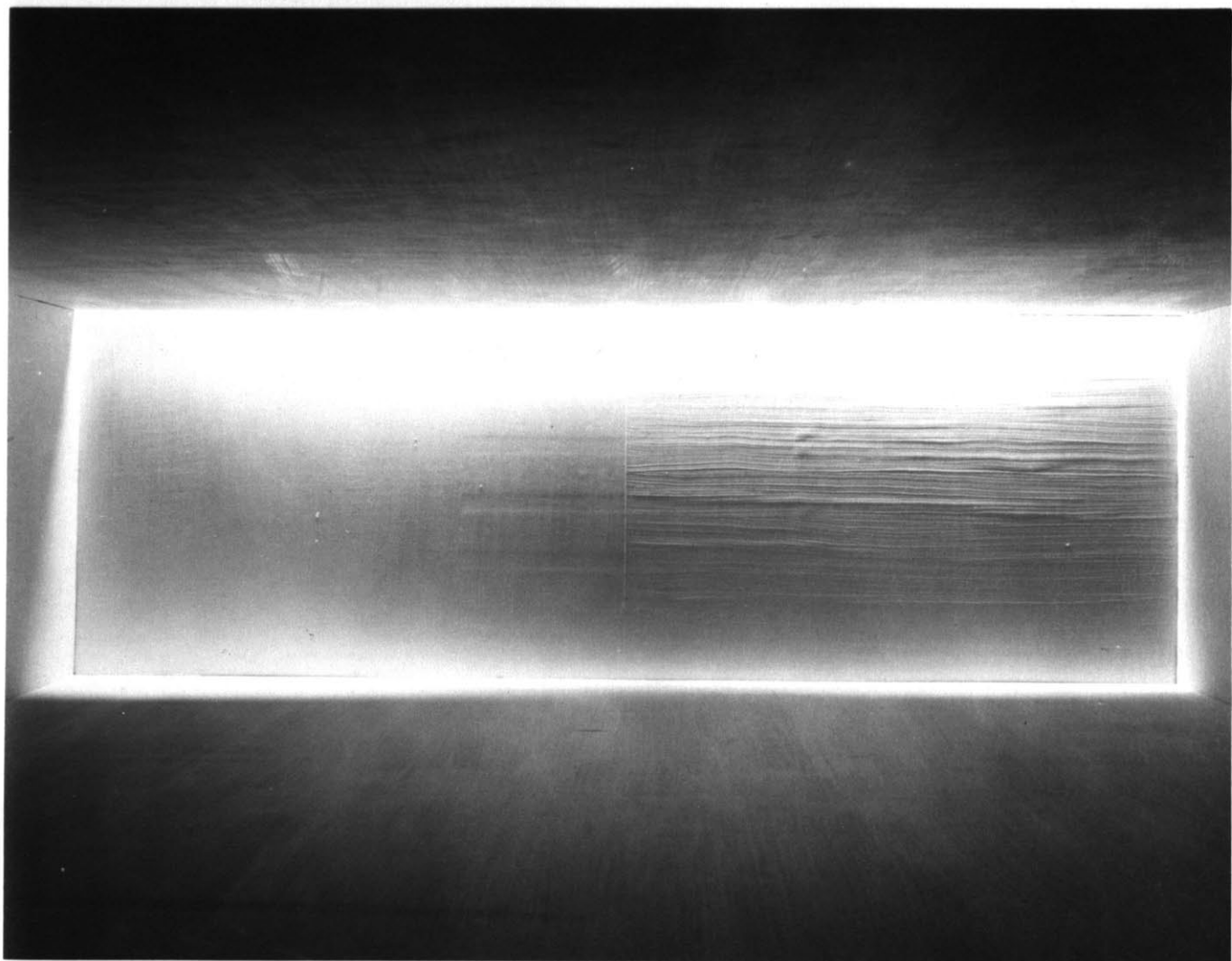

Vertical and horizontal texture

Light tangential in vertical direction

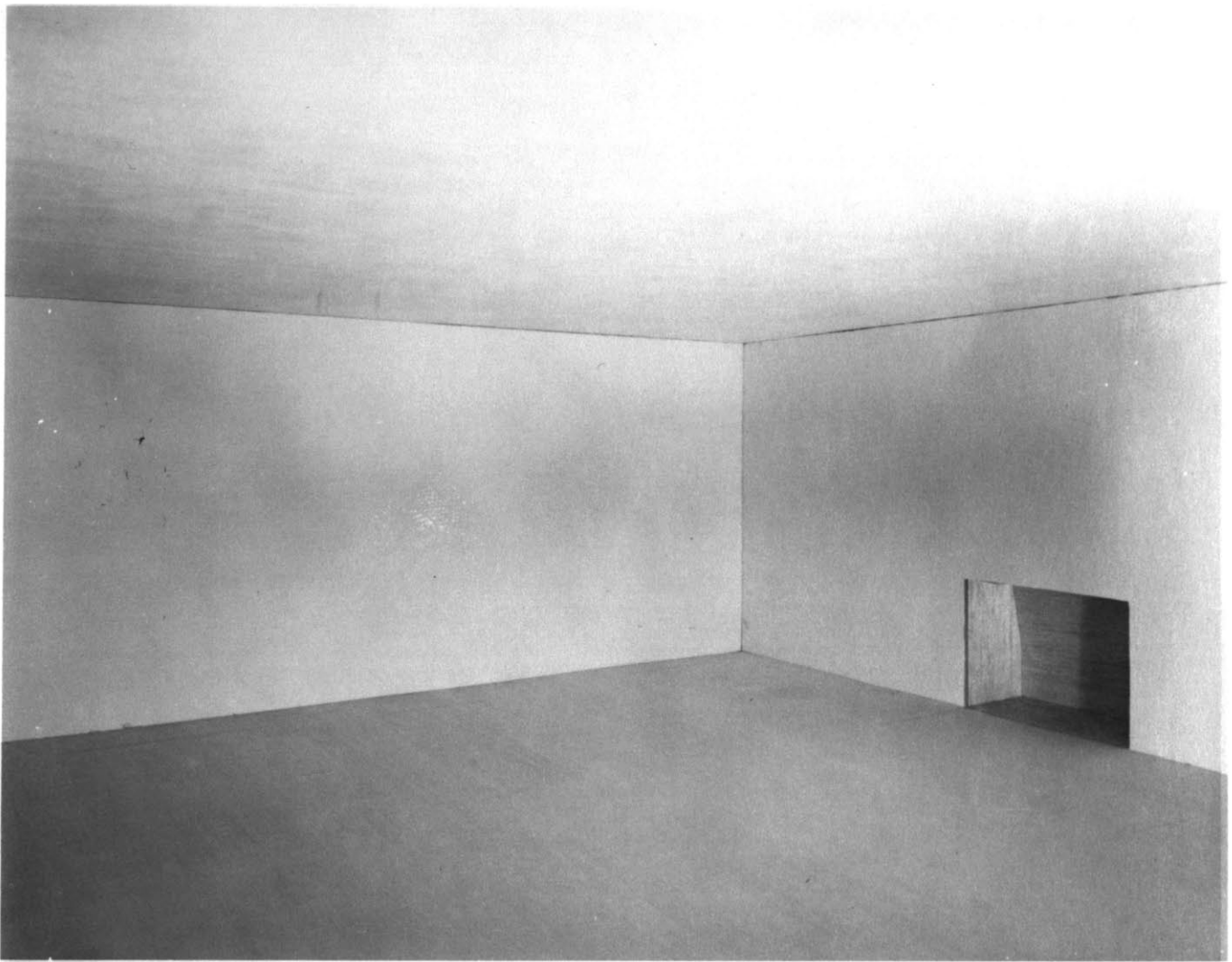

Horizontal, vertical, and stippled texture - Fig. 1

Flat light

In this and the following two photographs a vertical and horizontal texture has been created on the left wall and a stippled texture on the right wall. Prior to the creation of the textures on the left wall a varied texture had been present. Tangential lighting affects the surface quality to such an extent that even the undercoat of varied texture becomes evident in combination with the horizontal and vertical texture.

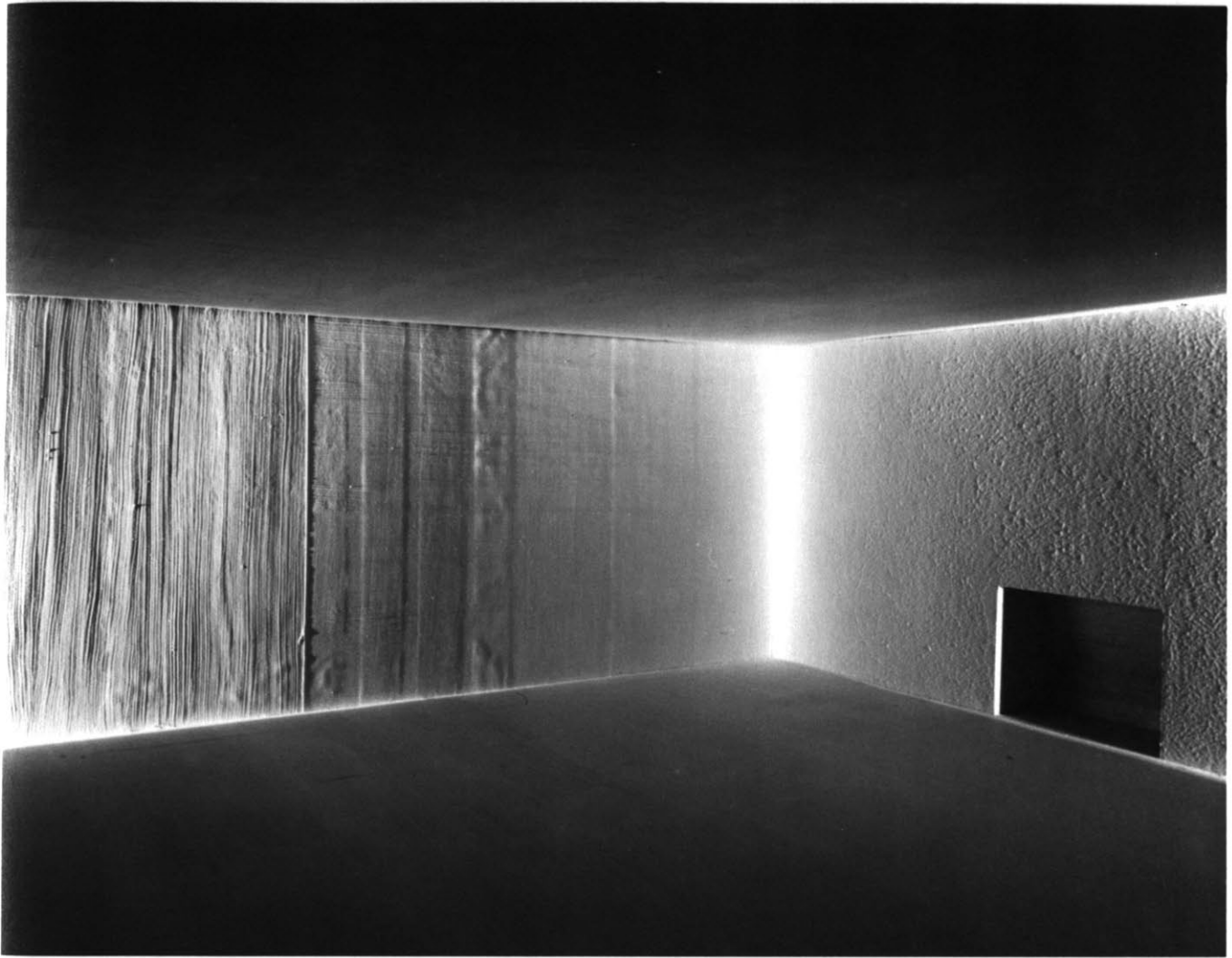

Horizontal, vertical, and stippled texture - Fig. 2

Horizontal tangential light

The vertical texture becomes accented while the horizontal texture is subdued. There is an illusion of bending of the walls.

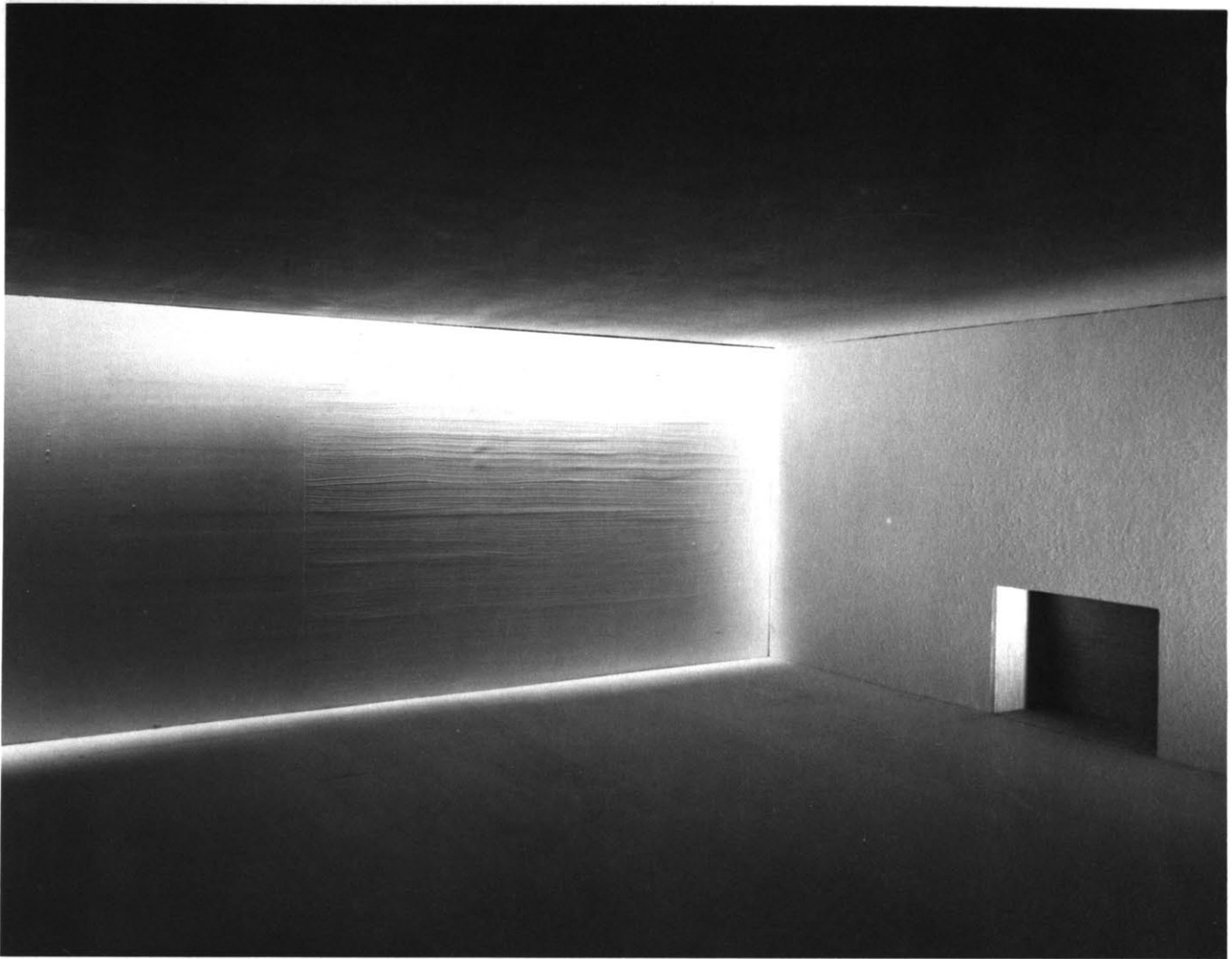

Horizontal, vertical, and stippled texture - Fig. 3

Vertical tangential light

The horizontal texture becomes accented while the vertical texture is subdued. There is an illusion of bending of the walls.

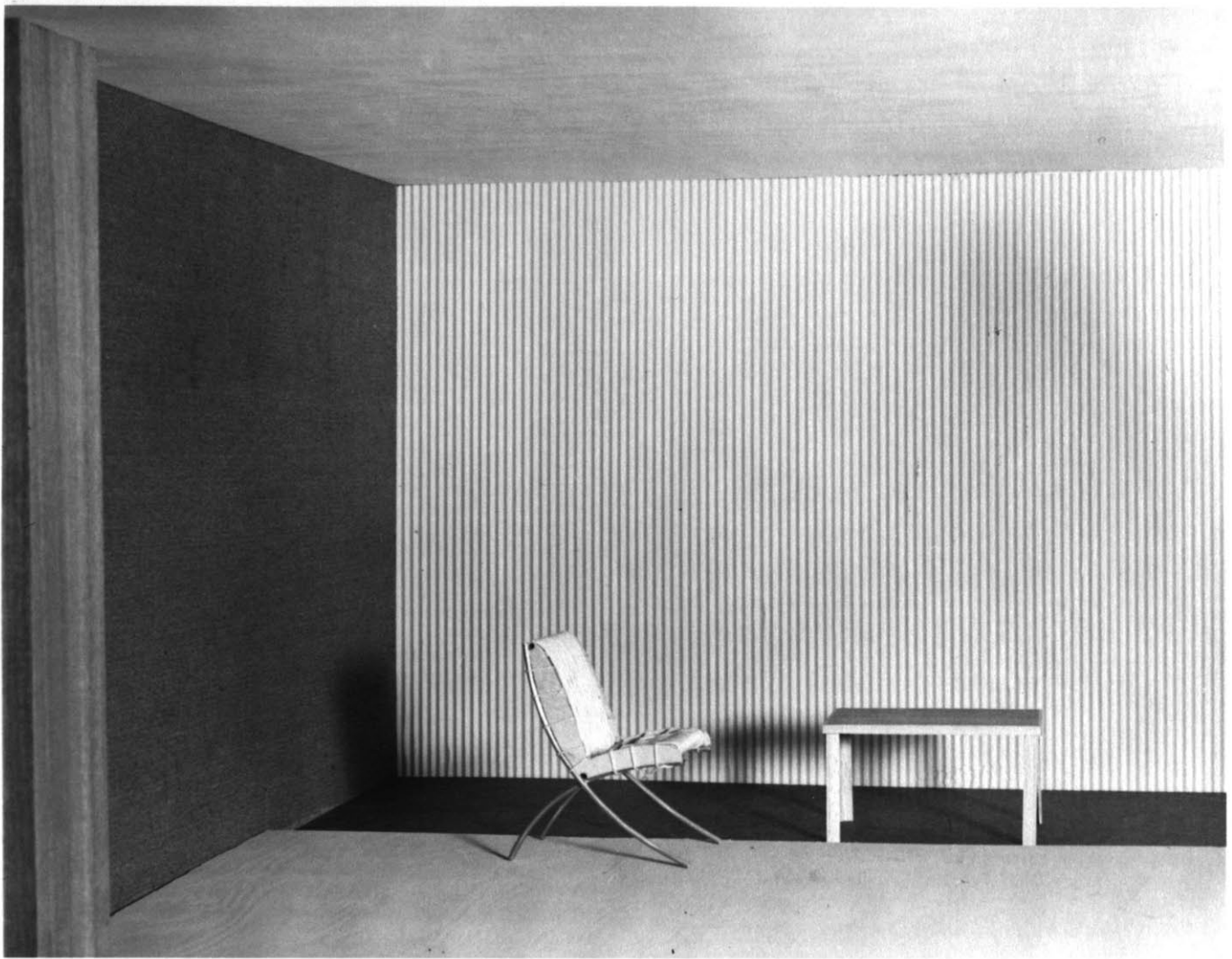

Floor-wood and texture A

Flat light

In this and the following photographs the illusion of interrupted extent is modified by texture.

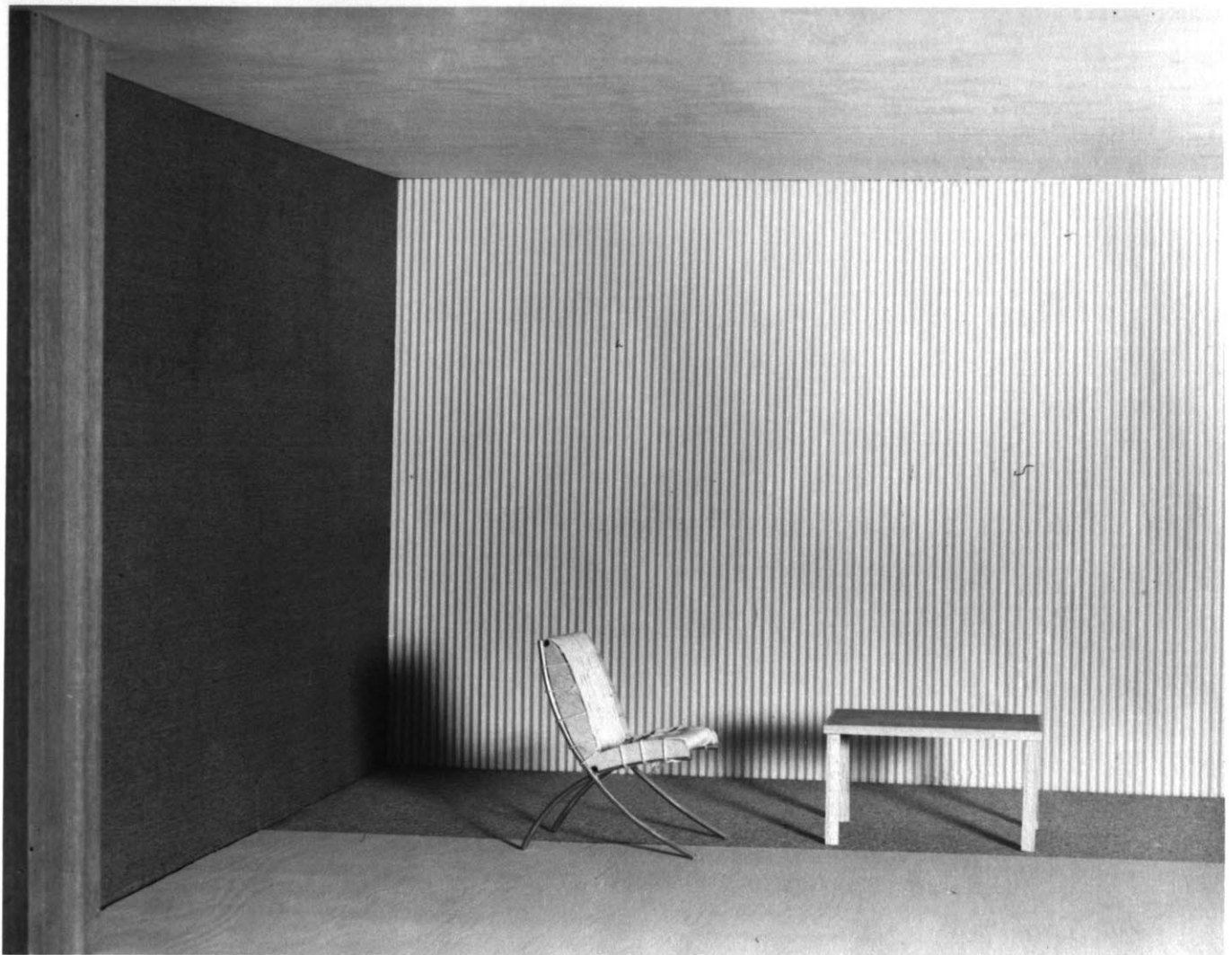

Floor-wood and texture E

Flat light



Floor-wood and texture D

Flat light

certain function but it would be likely to produce a monotonous environment. Rooms may be articulated with light by breaking them up into accented areas. Panels of light of any shape may be projected on surfaces. Spots of light may be introduced and patterns of light may be used. These accents may be produced by using flood lights, projectors, spot lights and even luminous paint. In the experimental work done, as illustrated on pages 64 through 67, several typical examples of the use of accents of light were demonstrated. Panels of light were produced, patterns were projected and fixed, and mobile spots were used. In the lighting design of a room all of a wall or only part of it could be flooded with light. When only part of a wall was lighted the lighted portion would usually be adjacent to those areas being used for work, study, etc., while the unlighted portions would be adjacent to the areas of repose. Projections of light used in this respect could have a definite shape thus forming a component of the aesthetic design of the room. Spot lights could be either fixed or moveable, having built-in dimmers and provisions for colored screens. These could be used in the conventional way of reinforcing the general illumination of a room when and where desired. Projections of light patterns could be used in the way decorative wall paper is used today; however, light would have the advantage of being flexible to the extent that the pattern could be changed, the intensity of the pattern increased or decreased, and the color varied.



Point spot source of light



Globular diffuse source of light

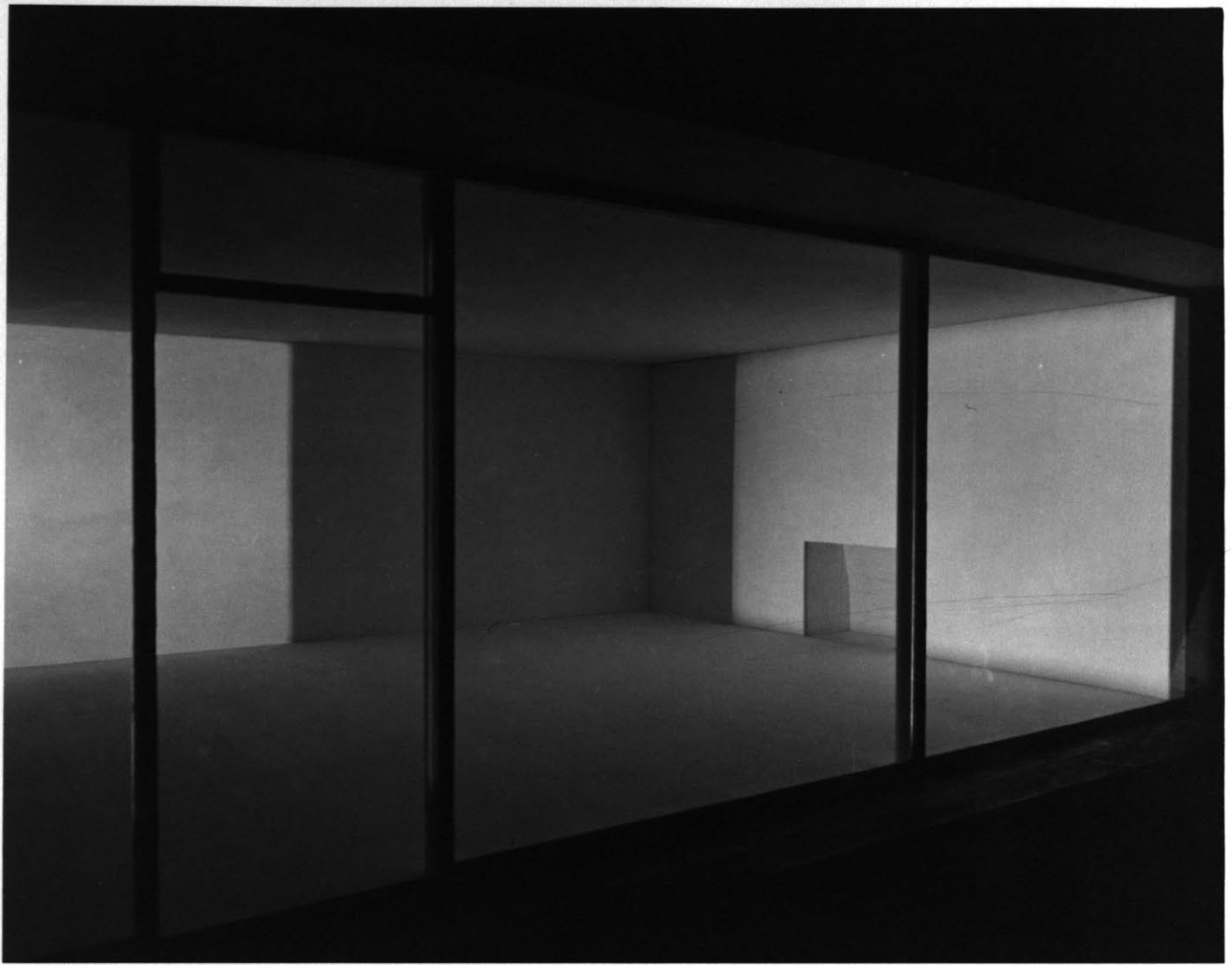

Panels of light may be used as accents where reinforcement of light environment would be desired.

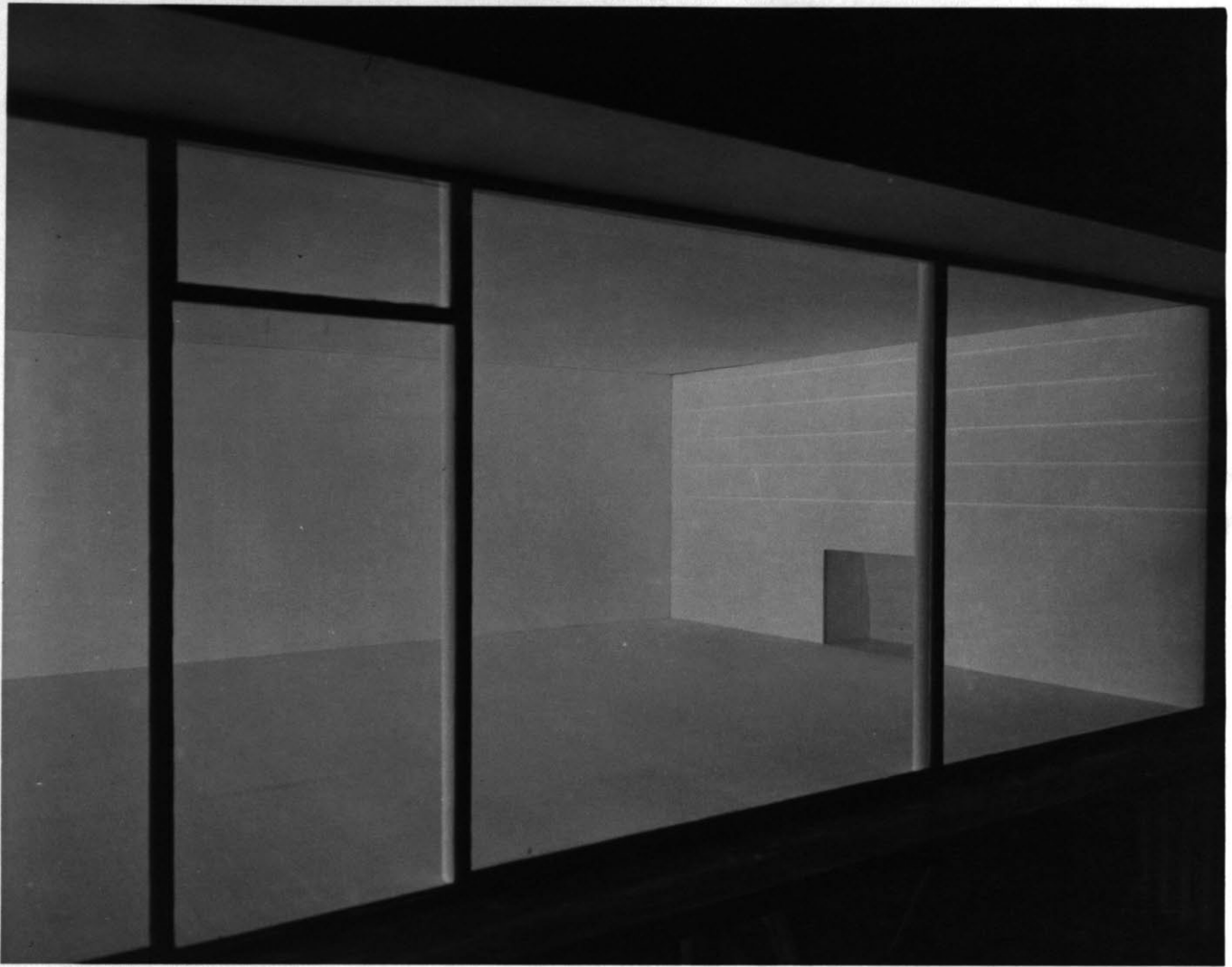

An example of how linear patterns of light may be used in a decorative sense in addition to the overall illumination. Linear light in this sense may be used to create many of the geometric illusions of space.

LIGHT IN STRUCTURE

In most illumination solutions light and fixtures are conceived as extraneous elements rather than as integral or structural units. Lighting may become part of the architectural form. One of the best examples of the use of light in this manner is found in Japanese architecture where panels of rice paper are not only used as wall elements but as sources of diffused light. Provisions may be made with this type of opaque material for the establishment of exterior floods to complement the illumination effect achieved during daylight conditions. Small trees or flowers could be planted between the opaque panel and the light source thus bringing shadows of plants into the room as a decorative media for the walls. Lucite is beginning to be used more frequently as a source of light in structures because of its light transmitting characteristics. Etched and brushed panels may be easily used to produce walls capable of emitting light in linear patterns or in a diffuse manner. As shown on page 69, lucite was used for one wall in the experimental model. The surface was brushed and light was projected on it from the exterior. An intimate relationship was established between the light source and the adjacent ceiling and wall - the three tended to merge.

COLOR

The use of color in lighting as a means of distorting visual space was discussed earlier in this report. To this possibility, the expressive possibilities of colored light, especially of the tints

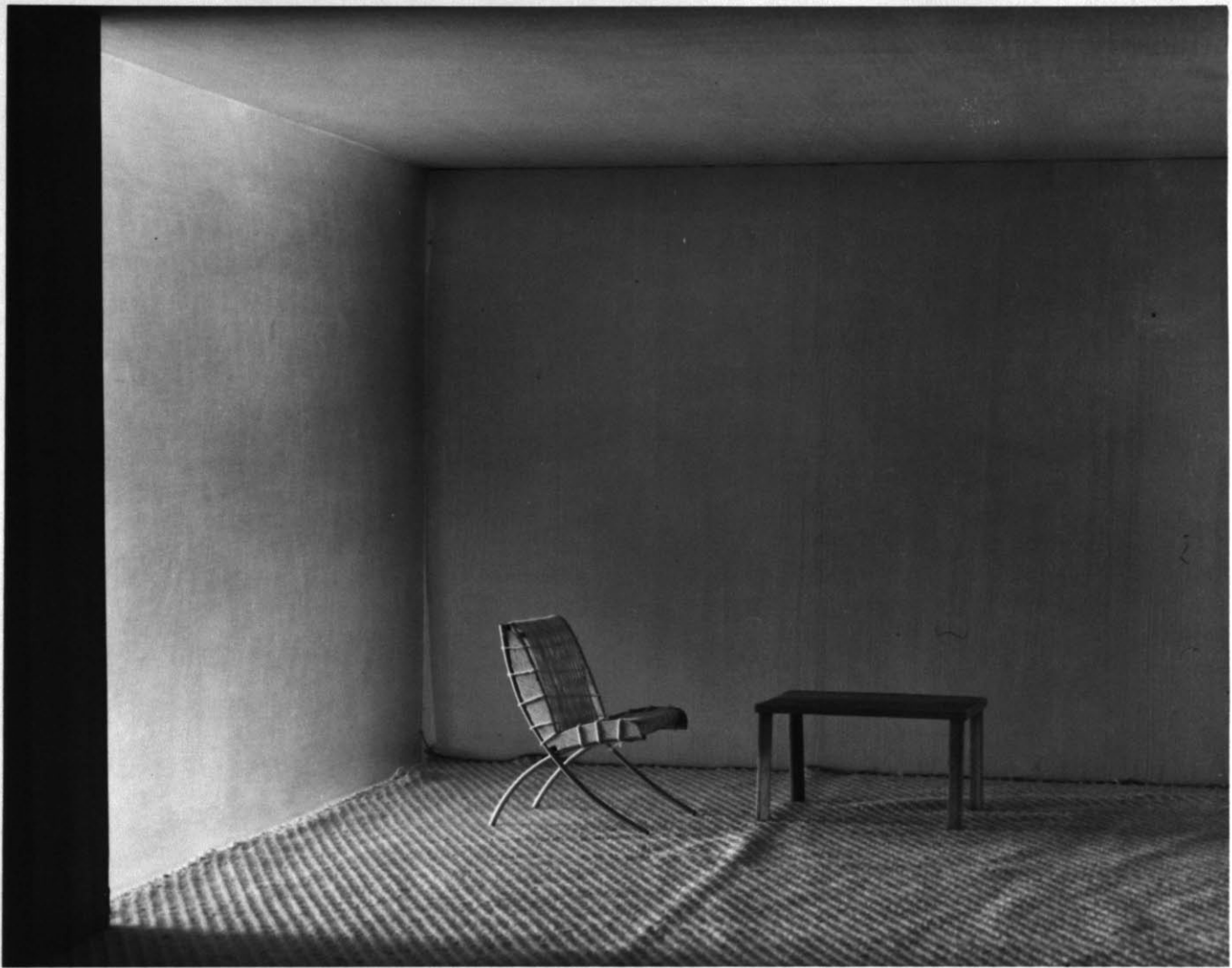

The sole source of light in this case is the left-hand wall which is an opaque panel lighted from behind. In this case the light source becomes a structural element of the room. An intimate relationship is established between the light source and the adjacent ceiling and wall - the three tend to merge.

or extremely unsaturated colors, may be added. There are many possibilities in applying colored illuminants to the decorative scheme of a room, permanently or for various special functions. How such tinted illuminants fit the spirit of an occasion or the mood of a room may be appreciated only through experiment. It is not within the scope of this report, however, to analyze the various psychological effects of colored light. In such interiors as living rooms, two or three different tints might be employed. A general soft illumination of warm tint might be chosen but this may be effectually emphasized here and there by contrasting tints in accents of light. Deeper tints of that used for general illumination might be employed for emphasis with good effect. However, there is a principle to be remembered in dealing with colored illuminants for their expressive value, namely, that colors live through contrast and die through lack of it. As an example, assume a room lighted with saturated red light. As the time of adaptation increases the purity of the red apparently disappears and the appearance of the whole room is that of a monochrome in an unsaturated orange. If a spot of any other color is injected into this room the red will be seen in all its purity. Contrast is essential to the life of colors. The architect may paint with light. He may utilize light, shade and color for his work as a painter uses pigment. The walls, ceiling, and other areas are the canvasses for light, shade, and color in lighting and the objects in the room provide real shadows. In a sense this aspect of lighting involves the combined principles of painting, sculpture and architecture.

LIGHT IN MOTION

Man is greatly a product of exterior environment. Through the countless years of evolution his seeing organs were developed to function under conditions of light in motion - the subtle movement of shadows, reflections on water, the movement of trees, plants and clouds. The constant exercising of the eyes caused by this experience seems to have a healthy physiological effect on the mechanisms of vision. Since the advent of the use of electricity as a means of producing light man has been subjected to a relatively static environment of artificial light. The number of factors involved in the problem of whether or not motion should become a part of artificial illumination make it impossible to reach any definite conclusion in a study of this length; however, the indications are that motion should be given serious consideration in the design of a light environment. Perhaps the satisfaction derived from an open fire may be in part related to an innate desire in man to experience light in motion. Mechanical means of producing such mobile effects could be used but it was the reaction of the observer that these effects would prove to be too monotonous and repetitious and would tend to give a feeling of irritation to anyone observing them for a long period of time. In an attempt to bring motion into the environment of the experimental model an opaque panel was illuminated from the exterior and a condition of planted trees was simulated between the light and panel. Thus the shadows of the trees were projected on the wall. From the interior the projections appeared as a decorative pattern subjected to



The opaque panel is again the light source but shadow decoration has been added. Exterior plantings could be used in this case creating not only a decorative but also a mobile effect tending to bring the exterior environment into the room.

constant subtle motion by the movement of air on the outside. In this way a source of light, a decorative, ever changing design and the experience of light in motion were achieved in one structural panel. Another possible means of achieving motion would be to suspend a mobile from the ceiling and have it lighted by a spot, thus projecting the shadow on some desired wall. The question of the type and amount of motion conducive to a healthy psychological environment would require an intensive study but the indication is that it could be used as a helpful tool by the architect.

ORGANIZATION OF LIGHT

The architect may use light to organize a room visually. There is a tendency to use lighting effects indiscriminately - creating accents of light where reinforcement of function is desired and not considering the overall effect. Light sources and the reflections of light make up the visual experience of a light space. This experience should have order and reason. The composition of a light space may be compared to that of a painting. The relationship of forms, shapes and areas to each other should be carefully considered. By being conscious of the interdependence of lighting effects, the architect would tend to create the light shell as a harmonious whole.

SUMMARY

It has been shown that the control of light is an effective means of modifying visual space. Gradation, brightness, color, accents, and motion may be used as capable means of establishing a desired visual environment. Light as a means of expression is a media that may be easily controlled and offers an optimum flexibility. It is an important and influential tool in the hands of the architect. It may be emphasized again that the architect should become aware of the fact that it is not sufficient to satisfy only the biological needs of man. The psychological factors determine the degree of satisfaction derived from the visual experience.

The writing of this thesis has brought to the attention of the author the need for further study in this particular field of lighting. The following are suggestions for additional research.

- (1) An intensive survey of the means and methods by which mobile light may be produced and a critical analysis of the uses and psychological effects of such light.
- (2) A comprehensive study of the use of various light tools as means of reinforcing specific functions carried on in a given space.
- (3) A study of the organization of light to point out the importance of conceiving light space as a harmonious whole.

BIBLIOGRAPHY

1. Moon, 6.17 Notes, M.I.T., 1945.
2. W. Harrison and E.A.Anderson, "Illumination Efficiencies as Determined in an Experimental Room", I.E.S. Transactions, 1916.
3. Parry Moon and D.E.Spencer, "Light Distributions of Rooms", J. Franklin Institute, 1946.
4. W. Harrison and M. Luckiesh, "Comfortable Lighting", Illuminating Engineering, 1941.
5. H. L. Logan, "Specification Points of Brightness", I.E.S. Transactions, 1939.
6. G. D. Berkhoff, "Aesthetic Measure", Harvard University Press, Cambridge, 1933.
7. M. Luckiesh, "Visual Illusions", D. Van Nostrand Co., New York, 1922.
8. Matthew Luckiesh and Frank K. Moss, "The Science of Seeing", D. Van Nostrand Co., New York, 1938.
9. M. Luckiesh, "Light Vision and Seeing", D. Van Nostrand Co., New York, 1944.
10. M. Luckiesh, "The Lighting Art", McGraw-Hill Co., New York, 1917.
11. F. M. Falge and C. E. Weitz, "Theatre Lighting", General Electric Co., Cleveland, 1938.
12. M. Luckiesh and A. J. Pacini, "Light and Health", Williams and Wilkins Co., Baltimore, 1926.
13. M. Luckiesh, "Color and Its Applications", D. Van Nostrand Co., 1921.
14. R. A. Cram, "Impressions of Japanese Architecture", Marshall Jones Co., Boston, 1930.
15. Chapman and Hall, "Symposium on Illumination", London, 1935.
16. T. Fuchs, "Stage Lighting", Little, Brown and Co., Boston, 1929.
17. C. Harold Ridge and F. G. Alfred, "Stage Lighting", Sir Isaac Pitman and Sons, London, 1935.
18. M. Luckiesh, "Torch of Civilization", G. P. Putnam's Sons, New York, 1940.