

AN APPLICATION OF THE SAR TISSUE METHOD WITH A VIEW TO THE ALAMO SQUARE AREA
(SAN FRANCISCO)

by

Hans-Christian Lischewski

Dipl. Ing. Technische Universitaet Karlsruhe, 1975

Submitted in Partial Fulfillment of the Requirements for the Degree of
MASTER OF ARCHITECTURE IN ADVANCED STUDIES

at the

MASSACHUSETTS INSTITUTE OF TECHNOLOGY

September 1978 - (i.e. February, 1979)

©MIT, 1978

Signature of Author _____

Department of Architecture
September 10, 1978

Certified by _____

Anne Vernez-Moudon, Thesis Supervisor
Assistant Professor of Architecture

Accepted by _____

Professor of Architecture Julian Beinart, Chairman
Departmental Committee for Graduate Students

Rotch
MASSACHUSETTS INSTITUTE
OF TECHNOLOGY

FEB 15 1979

LIBRARIES

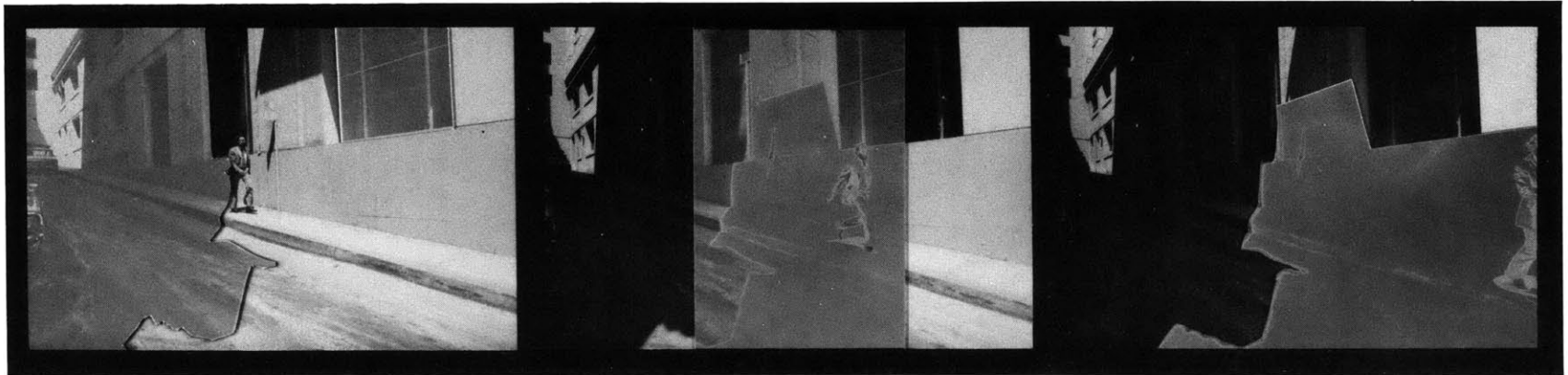

AN APPLICATION OF THE SAR TISSUE METHOD WITH A VIEW TO THE ALAMO SQUARE AREA (SAN FRANCISCO)

AN APPLICATION OF THE SAR TISSUE METHOD WITH A VIEW TO THE ALAMO SQUARE AREA (SAN FRANCISCO)

Submitted to the Department of Architecture on September 10, 1978, in partial fulfillment of the requirements for the degree of Master of Architecture in Advanced Studies.

ABSTRACT

This report summarizes a study of the block fabric around Alamo Square, San Francisco. It includes a survey of different morphological elements of the block fabric and analyzes patterns which are unique to this specific urban situation.

SAR 73, A Methodical Formulation of Agreements Concerning the Direct Dwelling Environment is applied to an analysis of a specific block.

A set of regulations is developed, based on these results, with the intention of proposing a methodical planning approach for renewal projects considering the morphological patterns of the existing environment.

A design example, based on the proposed agreements of the tissue model, is presented for a section of a block in the Alamo Square area.

THESIS SUPERVISOR: Anne Vernez-Moudon_____

TITLE: Assistant Professor of Architecture

ACKNOWLEDGEMENTS

I would like to take the opportunity to thank my thesis advisor, Professor Anne Vernez-Moudon, for providing me with the opportunity to work with her for a period of nearly two years and for her patience and engagement in this project.

Professors John Habraken, Eric Dluhosch, and Kevin Lynch supported my efforts and provided important feedback while the project was in progress.

I want to also thank Professor Nicholas Negroponte for providing me with the opportunity to work with the Architecture Machine Group.

I would also like to mention the following people, who supported this project:

Professor Antero Markelin,	Technische Universitaet Stuttgart
Professor Paul Schuetz,	Technische Universitaet Karlsruhe
Professor Ottokar Uhl,	Technische Universitaet Karlsruhe
Randy Delahanty,	San Francisco Architectural Heritage Society
Jim Demetre,	San Francisco Redevelopment Agency
Dick Gamble,	San Francisco Department of City Planning
Jeremy Kotas,	San Francisco Department of City Planning
Daniel Salomon,	Architect, San Francisco
Marc Winogrand,	San Francisco Department of City Planning

I want to thank Martha Leinroth. Only with her help was I able to start and to finish this report.

Preparatory studies for this thesis were funded by a grant from the National Endowment for the Arts and by the Graham Fund (MIT) with a traveling scholarship to San Francisco.

FOREWORD

Revitalization of urban quarters has become one of the most important tasks for planners and architects during the last decade. Proposals to change or renew an existing urban area are made in order to improve the quality of the environment. Such efforts can create problems. Parties involved in the planning process may disagree on what constitutes quality and which improvements should have priority.

People identify with their living environment. Although they desire improvements, they want to retain the familiar character of their surroundings, especially when they consider the area as their home. This conflict often creates problems of an emotional nature, which can only be solved satisfactorily if the renewal process becomes transparent and permits objective evaluation. A starting point for the solution of the various problems can be the application of a method which enable the comparison of renewal proposals with the existing situation.

The Alamo Square area in San Francisco is an old residential district which is now in the process of renewal. Application of the SAR 73 method to the Alamo Square area proposes an alternative of evaluating the existing block fabric and systematically developing new tissue models.

CONTENTS

1.0	INTRODUCTION	
1.1	URBAN HOUSING	12
1.2	SAR 73 METHOD	14
1.3	APPLICATION OF SAR 73 TO BLOCK TISSUES IN SAN FRANCISCO	16
2.0	ANALYSIS	
2.1	GENERAL DESCRIPTION OF THE ELEMENTS OF THE VICTORIAN BLOCK TISSUE	19
2.11	General Description on the Urban and Regional Level	19
2.111	The street grid	20
2.112	Topography	20
2.113	Correlation of street grid with topography	20
2.12	General Description on the Block Level	21
2.121	Circulation systems	21
2.122	Lot subdivision	24
2.123	Intermediate, corner and key-lots	26
2.13	General Description on the Building Level	28
2.131	Building types; number of floors	28
2.132	Types of plots	29
2.133	Correlation of plot and building	29
2.134	Elements of Building	30
2.1341	Base	31
2.1342	Main house or box	35
2.1343	Roof	36
2.1344	Add-ons	42
2.1345	Characteristics of the Victorian residential building	37

2.14	Correlation of Buildings	42
2.141	Base area	42
2.142	Main floor area	43
2.143	Roof area	44
2.15	Formal Characteristics of the Streetscape	44
2.2	CHANGE WITH(OUT) LOSS – RENEWAL AND RESTORATION PROJECTS AROUND ALAMO SQUARE	49
2.21	Problems of Urban Change	49
2.22	New Developments	51
2.23	Architectural Groupings for Mapping Purposes	54
2.24	The San Francisco Redevelopment Agency	56
2.25	Summary: Sar 73	60
2.251	General comment	60
2.252	The method	60
2.253	Elements	61
2.254	Functions	63
2.255	Notations of agreements	65
2.256	Documents and the tissue model	71
2.257	Application of the tissue model	77
2.3	ANALYSIS OF BLOCK 1155	80
2.31	Block Fabric in Relation to Adjacent Regions	80
2.32	Block Fabric in Relation to Adjacent Blocks	83
2.33	The Morphology of the Block	83
2.331	Relation of built and open elements	86
2.332	Streetscapes – public and semi-public spaces	86
2.34	Characteristics Which Influence the Morphological Patterns of the Streetscape	90

2.35	Zoning Analysis of Block 1155	93
2.351	Dimension and location of buildings as the basis for a zoning system	96
2.352	Characteristics of the B-zone	96
2.353	Characteristics of ob-margins	96
2.354	SAR 73 zoning distribution for Block 1155, as notated in an agreement sheet	101
2.4	GENERAL ZONING DISTRIBUTION FOR THE ALAMO SQUARE BLOCK FABRIC	103
3.0	DEVELOPMENT OF RULES FOR TISSUE MODELS, BASED ON PRESENT DENSITY STANDARDS OF THE ALAMO SQUARE AREA, WHICH ASSIMILATE THE EXISTING MORPHOLOGY	106
3.1	TISSUE TYPE GROUPS (VARIATIONS OF THE SAME BUILDING FORM OR CIRCULATION SYSTEM)	107
3.2	TISSUE TYPES	109
3.3	FUNCTION MODELS	114
3.4	TISSUE MODELS	124
3.41	Rules for a Tissue Model (Proposal for a Formulation of Standards)	124
3.411	General rules defining location and dimension of zones and margins	124
3.412	Rules regulating the correlation of built elements (support sectors)	137
3.413	Rules regulating location and dimension in separate sectors (detachable units)	149
3.414	Hierarchy of tissue model rules	156
3.42	Calculating Density with the Tissue Model	157
3.421	The physical support (Support System A)	160
3.422	The non-physical support (Support System B)	168
3.423	Sector examples for townhouses, according to the zoning distribution of Support System B	174
3.43	Tissue Model of Tissue Type I _A	185
3.44	Tissue Model of Function Model IV _{C2} , Based on General Zone and Block Dimensions	191

3.5 APPLICATION OF BUILDING TYPES IN TISSUE MODEL IV	221
C2a	
4.0 CONCLUSION	228
5.0 APPENDIX: A COMPUTER-AIDED GRAPHIC QUANTIFICATION TECHNIQUE FOR TISSUE MODELS	231
6.0 BIBLIOGRAPHY	234

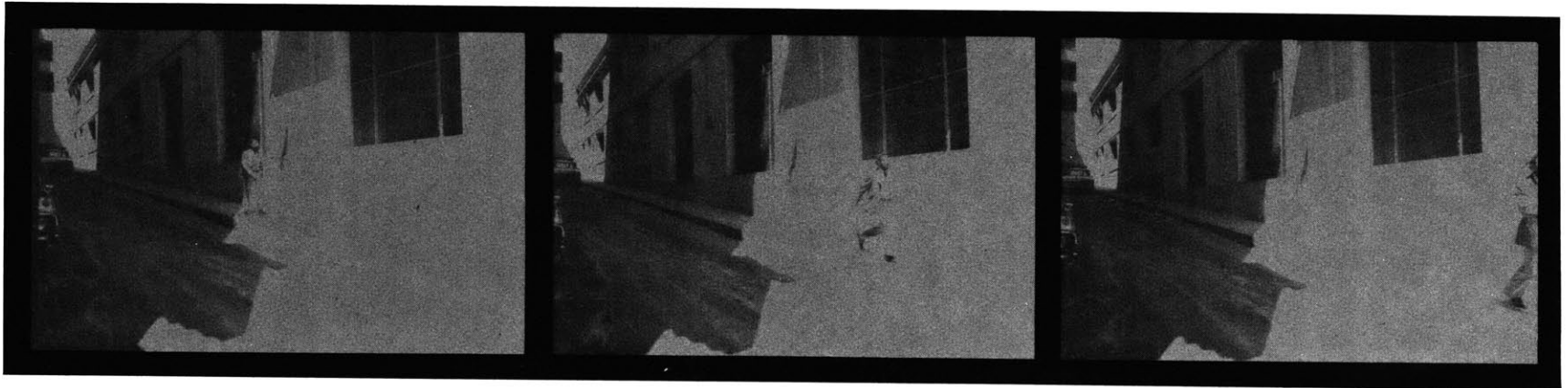

1.0 INTRODUCTION

1.1

URBAN HOUSING

The early growth of San Francisco occurred at the same time as European cities were expanding because of growing industries. In Europe, there was a large migration from the country to the cities, creating an enormous need for residential space for workers in the factories.

In San Francisco, however, the dominant growth factor was not industry, but the Gold Rush. Because of its geographical location and large natural harbor, San Francisco became an important place for business and trade. Within twenty years, the population had grown from 500 to 150,000. The growing population was not industrial workers, as in Europe, but businessmen and tradesmen.

The spreading expansion was controlled by a perpendicular street grid which organized and regulated dimensions of block areas. Various types of individual houses were built, richly ornamented with prefabricated details, along the streets defining these blocks. Based on modules such as plot dimensions and dwelling dimensions and location, certain patterns of built elements characterized the Victorian streetscape.

The area around Alamo Square is typical of such development, showing a clear hierarchy of rules, from a community level (the layout of streets and block dimensions) to a more individual level (lot width and building size) to the lowest individual level (style and ornamentation).

Increased density caused by the lack of residential space in other areas of San Francisco after the fire of 1906, growth of small factories and shops, and the middle class exodus to the suburbs reduced the attractiveness of this area as a residential region. Large parts of this area have become slums and need renewal.

There have been new developments and new building. Most of these developments do not assimilate the characteristics of this neighborhood. They often have very different circulation and morphological patterns and, because of different modern construction methods, do not relate to the scale of the existing Victorian built environment.

The renewal process in this region is in progress. Planners have become conscious of the unique character of this built environment. New regulations for zoning and density appear to take into account the specific characteristics of this area and, with the further assimilation of these characteristics, these regulations can provide a chance to revitalize this residential district. New methods of development and construction and different regulations, on the community as well as the individual level, must be considered. Future guidelines and designs for the revitalization of this area will have to consider these criteria.

The City Planning Code of San Francisco, which contains general rules for the whole city, is still the basis for the design of development projects. Development of more specific regulations for different regions of San Francisco is in progress. An example of such a study is given in section 2.23.

1.2

SAR 73 METHOD

This method is a tool for architects and planners. Based on the consideration of existing patterns of a block tissue, its objective is to transfer, or to transform, these patterns into new projects.

SAR (Stichting Architecten Research) was founded in 1965 by a number of architectural firms with the support of the Bond van Nederlandse Architecten, an association of Dutch architects. The work of SAR has been guided by the conviction that users must play an active role in the housing process.

The research of SAR focused initially on the role of the dweller with respect to his dwelling. A dwelling was differentiated into the detachable unit, an area where the dweller has responsibility and control, and the support, an area which lies beyond the control of the dweller and represents the physical framework of decision-making power. Based on these concepts, the SAR 65 method was developed. SAR 65 was concerned with housing structures and was based on the systematic formulation of design decisions by way of agreements, obligatory determinations in the design process. In the hierarchy of agreements, each subsequent decision in the design process becomes another agreement. This method regulates the design process of the dwelling place.

Further work investigated those aspects of living which lie outside the dwelling. Different elements of a neighborhood, such

as streets, squares, buildings, and traffic circulation, were defined as part of a neighborhood, where responsibilities must be separated into areas of collective decision making and areas over which the users assume individual responsibility. This was the basis of the method of SAR 73.¹

SAR 73 is based on decision making by agreements on the tissue level of a built environment. An important concept introduced in this method was that of theme, which means that certain elements and their interrelations reveal patterns which are characteristic of a specific living environment. The theme characterizes an area and is the basis for comparison and evaluation of alternative agreements. A more detailed description of SAR 73 will be given in section 2.25.

¹Stichting Architecten Research, SAR 73, The Methodical Formulation of Agreements Concerning the Direct Dwelling Environment. (Eindhoven, Holland: Stichting Architecten Research, 1973)

1.3

APPLICATION OF SAR 73 TO BLOCK TISSUES IN SAN FRANCISCO (ALAMO SQUARE)

The built environment of the region around Alamo Square contains certain patterns of circulation. Built elements interrelate in specific ways which can be typologized and expressed in a model. Dwellings themselves have repetitive elements with a certain amount of variations. These patterns may be defined as the theme of this specific environment. In this case, they have an historical background and present a specific interweaving of buildings and spaces.

Using SAR 73 in this context means applying a systematic method to analyze the existing situation, and developing a framework of alternative agreements which assimilate the characteristics of this area for future revitalization projects.

The following chapters define the general elements characteristic of this area and their patterns in this environment. This description is a short summary of a more comprehensive study entitled "Urban Form and Change."² This study identifies the parameters of the city's physical structure and defines typologies

²Anne Vernez-Moundon, Principal Investigator, "Urban Form and Change." Sponsored by the National Endowment for the Arts (1976-78) and various MIT funds including the Bemis Fund, the Undergraduate Research Opportunities Program, and the Division for Study and Research in Education.

of the elements of the fabric and their relationships. It also demonstrates the changes to which the elements of the physical fabric have been subjected over time.

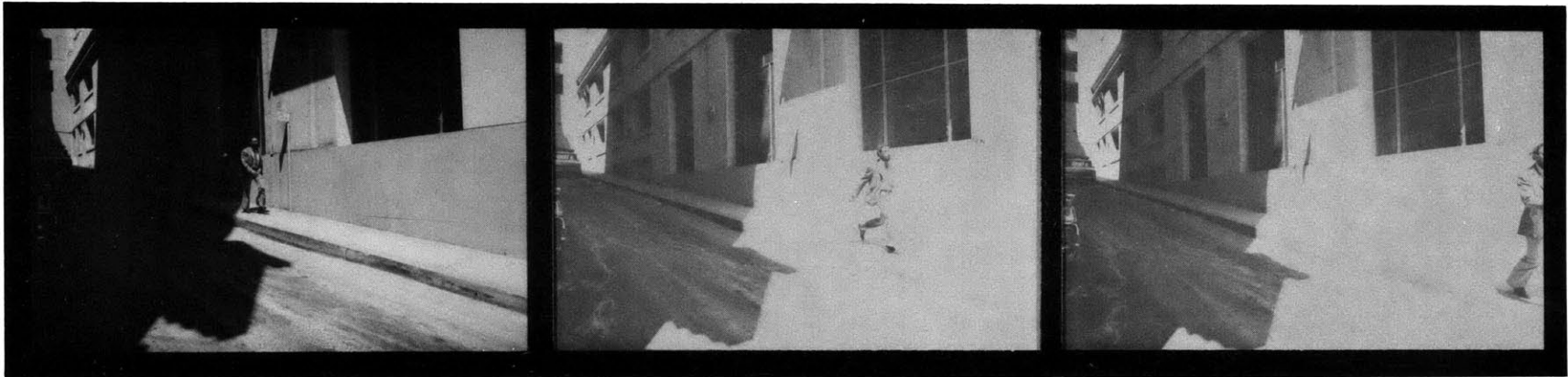

2.0 ANALYSIS

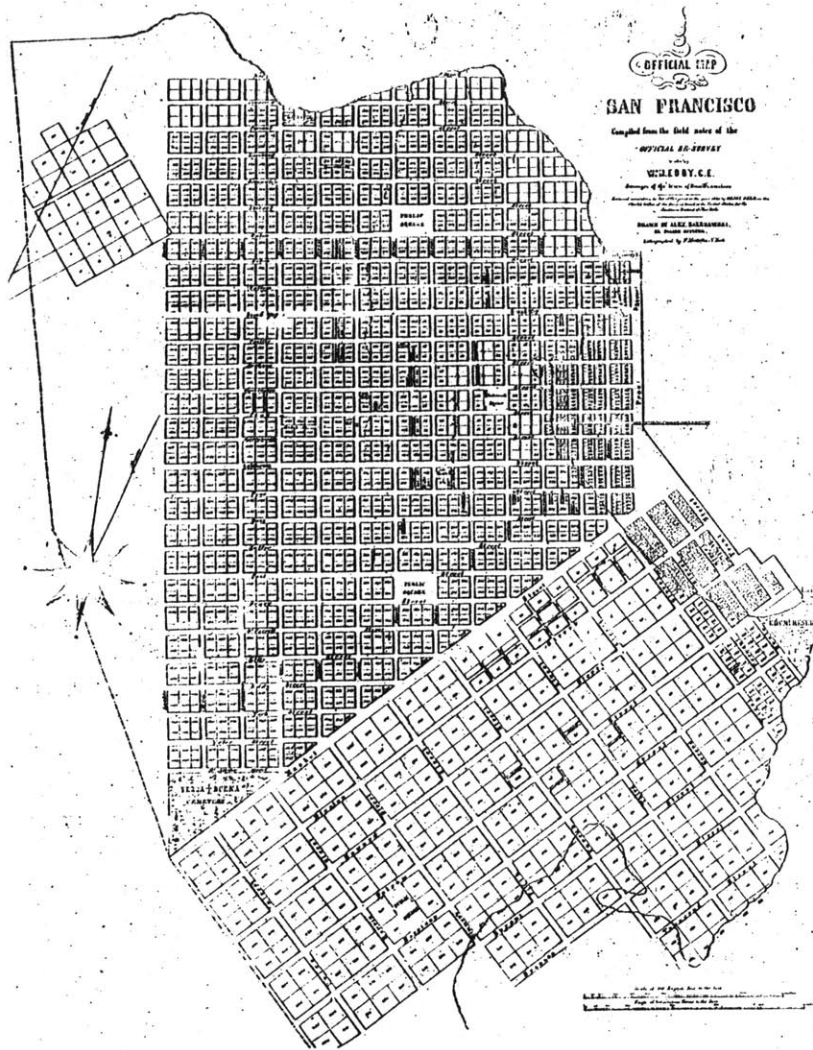

Fig. 1 Map of San Francisco, 1849

2.1 GENERAL DESCRIPTION OF THE ELEMENTS OF THE VICTORIAN BLOCK TISSUE

2.11 GENERAL DESCRIPTION ON THE URBAN AND REGIONAL LEVEL

Alamo Square is located in the Western Addition of San Francisco, a region which is an extension of the first settlement which had its nucleus at the Western Cove along Market Street.

In 1839, the area was surveyed and laid out in a rectangular grid by Jean Vioget to facilitate existing land claims. (Fig. 1) This street grid reached to Larkin Street and was extended in 1851 to Divisadero Street by the Van Ness Ordinance. The ordinance also established four public squares on hilltop sites upon which it was impractical to build. Alamo Square is one of these public squares. The Western Addition was later extended to Arguello Boulevard.

The Alamo Square area was developed as a purely residential district during the period of growth after 1850.

2.111 THE STREET GRID

The generic layout of the city as presented in the Vioget map was based on the vara, a Colonial Spanish unit of measurement equal to thirty-three inches (82.5 cm). A grid measured in varas was the basis for the location of streets and areas provided for residential development. In the Western Addition, most streets were laid down in a perpendicular grid with a width of twenty-five varas (68'9" or 20.625 m) in both directions. Important commercial streets such as Divisadero are thirty varas (82'6" or 24.75 m) wide.

2.112 TOPOGRAPHY

The topographical aspect is one of the most characteristic elements of the Bay Area. Within a very short distance, the elevation may climb from sea level to 800 feet. This change of elevation is not smooth, but creates hills and slopes of varying steepness.

This natural element conflicts with the artificial format of the rectangular street grid, resulting in a unique variety of slope adaptations which characterize most streets around Alamo Square.

2.113 CORRELATION OF STREET GRID WITH TOPOGRAPHY

The Alamo Square area includes both streets with steep slopes and streets which are nearly flat. The form of the individual



Fig. 2 Montgomery Street from Broadway

built element and its correlation with adjacent buildings is very different for these two situations. Within a relatively short distance, the conflict of street grid and topography creates a changing variety of slope adaptations, necessary set-backs, and access variations.

The interrelation of street grid and topography also influences circulation and parking. Very steep slopes require perpendicular parking, one way traffic, or a ban on through traffic. In areas such as Telegraph Hill, Buena Vista Park and Mount Davidson, the topography creates extreme constraints on parking and traffic. (Fig. 2) The situation around Alamo Square permits normal traffic circulation and parking parallel to the sidewalk.

2.12 GENERAL DESCRIPTION ON THE BLOCK LEVEL

2.121 CIRCULATION SYSTEMS

The original street width of twenty-five varas (68'9" or 20.65 m) included the sidewalk area. This distance was measured between lot lines on opposite sides of the street. An average sidewalk width of 10 feet provided a space of 48'9"

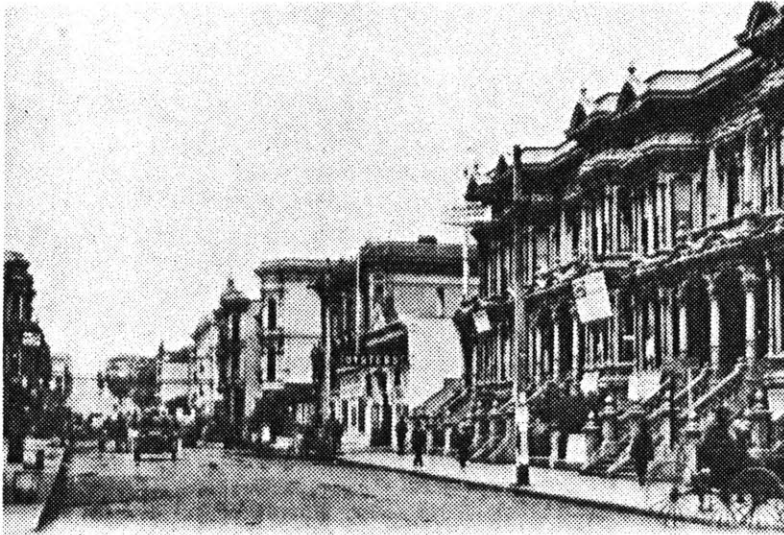

Fig. 3 Golden Gate Street near Webster Street (1920)



Fig. 4 Webster Street from McAllister Street (1977)

(14.625 m) for parking and vehicular circulation in both directions (Fig. 3) This width is sufficient for today's circulation standards. It permits parallel parking on both sides of the street and vehicular circulation in both directions. Only a few streets, such as Van Ness Avenue and Webster Street between Grove and Geary Streets, are wider than the typical street width; they generally function as traffic arteries (Fig. 4).

The generic street width of 68'9" also provides sufficient lighting for buildings on both sides of the street and permits a range of landscaping in the sidewalk area. This dimension of width also creates a correspondance between elements on opposite sides of the street. The proportions of buildings and the distance between them create a street space where elements are perceived in morphological relation. Wider streets, such as the section of Webster previously mentioned, do not have this quality. The distance between buildings on opposite sides of the street is too large to generate a linear space with the closed character of more narrow streets.

In a section of the Western Addition between Larkin, Webster, Haight and Geary Streets, the

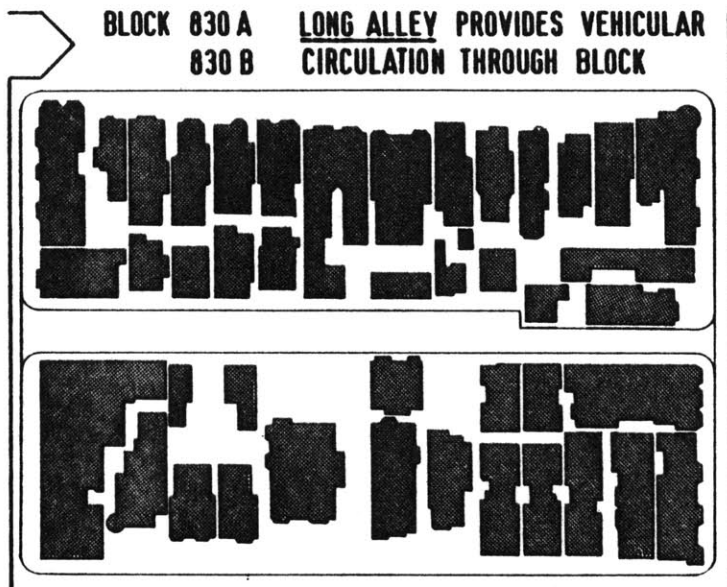

Fig. 5 Block 830 (1976)

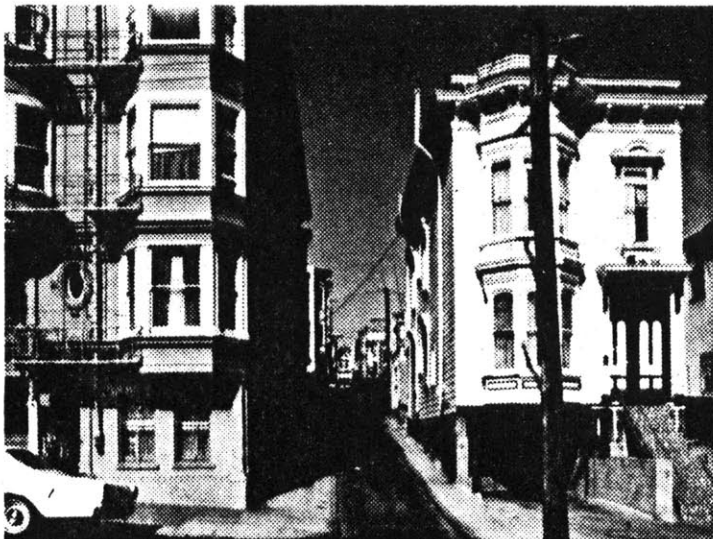

Fig. 6 Block 830, view from Laguna into Linden

basic block was divided lengthwise. This generated a long alley, which provided additional vehicular access to the inner block area. This subdivision was made in 1876, most likely to provide additional small plots affordable by persons of lower income. Another reason for this different circulation pattern may have been real estate speculation: smaller plots were easier to sell and provided more profit.

Because of the fixed location of major streets, the alley had to be narrow. Today, alleys function only as vehicular access to the back. In the nineteenth century, both sides of the plots between major streets and the alley were developed separately, with buildings facing on both the major streets and the alley. Buildings along major streets had the same size as those built in the basic blocks. Dwellings built along the alleys were smaller in depth and height. Block 830A is an example of such a plot subdivision (Fig. 5). Today, most buildings along the alley relate to the building behind them which faces on the main street.

The short alley is a variation of this circulation pattern. This subdivision is rare compared to that created by the long alley. Nevertheless, it is an interesting way to provide access to the

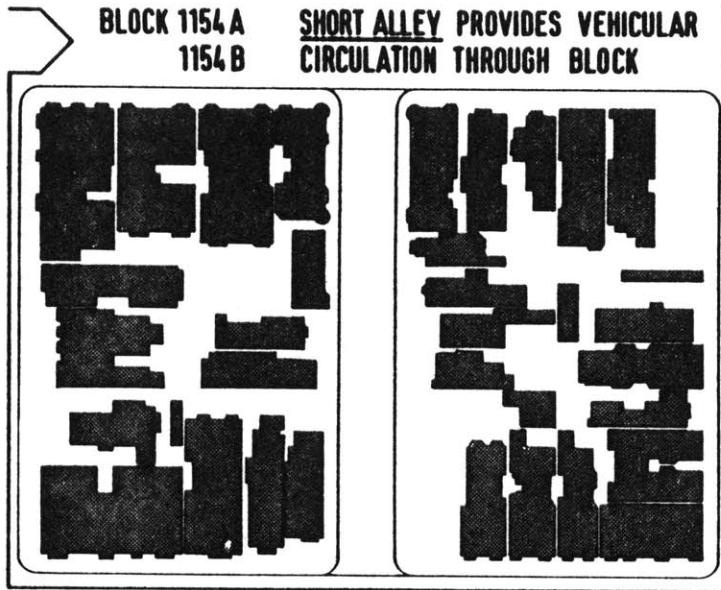

Fig. 7 Block 1154 (1976)



Fig. 8 Varennes Street, Telegraph Hill

inner block and to develop this zone for residential use.

Dimensions of the main street limit possible lot arrangements. In this case, there is more space for each building facing on the alley than in blocks cut by a long alley. This makes it possible to locate deeper buildings along the alley. Block 1154B presents an example of this block type. As in block types with long alleys, most of the buildings are oriented to the major streets. The short alley provides access to seven buildings (Fig. 7). Because of the deeper lot dimensions, buildings along the alley have set-backs.

Some short alleys have a continuous facade of attached buildings. The distance between facades on either side of the alley is only 25' (7.5 m). (Fig.8)

2.122 LOT SUBDIVISION

The basic block size north of Market Street is 412'6" x 275' (123.75 m x 82.5 m). These dimensions are in accordance with the grid laid down by Jean Vioget and are based on the vara module, being 150 by 100 varas. (Fig. 9a)

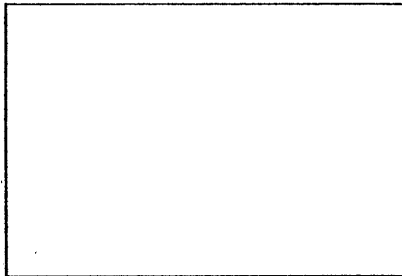

Fig. 9a Generic Block Area

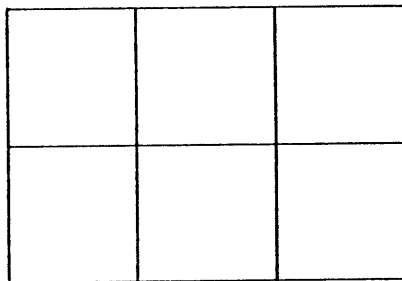

Fig. 9b Generic Subdivision into Six Parcels

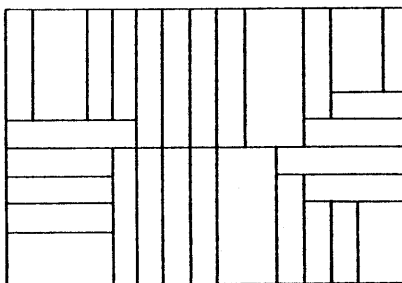

Fig. 9c Lot Subdivision of Generic Parcels

Blocks without alley circulation were divided into six parcels, each fifty by fifty varas (137'6" x 137'6", 41.25 m x 41.25 m). (Fig. 9b) Parcels of these dimensions still exist in the Alamo Square area (e.g., Blocks 798 Grove and 824 Fell).

The majority of these parcels were divided further (Fig. 9c). Analysis of the lot subdivision shows that parcels at the corners have a variety of subdivision combinations while center parcels on the long sides of the block have similar subdivision proportions.

A parcel fifty varas wide was divided into five lots, each ten varas wide (27'6", 8.25 m). Including areas from adjacent corner parcels, combinations of different lot widths were possible. The most common dimensions are 25' (7.5 m), 27'6" (8.25 m) and 30' (9.0 m). Lots of these widths have a depth of 137'6", which provides an average ratio of private land frontage to depth of one to five.

Subdivision of corner parcels was based on the importance of adjacent streets and type of development. If parcels were built with similar building types (e.g., Block 776 Golden Gate), the lot subdivision patterns were not as differentiated as they were for individual developments with varying types and sizes (e.g., Block 824 Oak). By shortening lot

depth, it was possible to divide a corner parcel into seven separate lots.

2.123 INTERMEDIATE, CORNER AND KEY-LOTS

Three kinds of lot locations, resulting from different lot subdivisions and locations of generic parcels, may be defined. Each of these location types has specific characteristics which are repeated in every block and may be defined as patterns of the existing block tissue (Fig. 10).

Intermediate lot locations. These are to be found along the long sides of a block. They usually have a depth of 137'6" (41.25 m). In some cases, the depths of intermediate lots in a block may differ, but their combined depths equal 275' (82.5 m).

Corner lot locations. These may vary in depth and in orientation. In the typical lot location, a lot is oriented to two streets. If a lot is oriented to the longer side of a block but shorter than 137'6", its location is called a corner location. This means that the lot is influenced by lot subdivision patterns for the corners.

Key-lots. These are located between the corner lots on the short sides of a block. They differ from intermediate locations by depth, which may

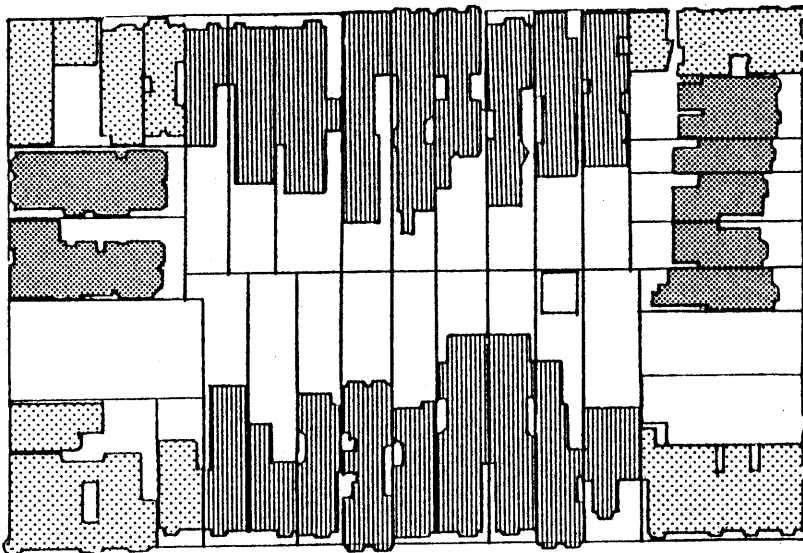
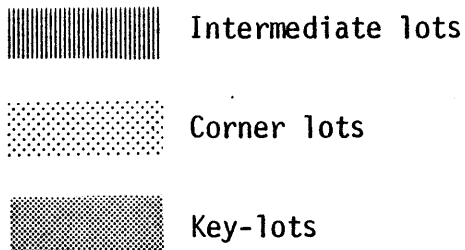

Fig. 10 Block 821

be less than 137'6" (41.25 m) and oriented to the short, instead of long, sides of the block.

To simplify lot location typology for the analysis and a later computer-aided evaluation system, this study differentiates only two location types, based on the lot subdivision patterns of generic parcels. Key-lots are combined with corner lots, becoming corner location areas; intermediate lots are combined to become intermediate location areas. Each block will have four corner location areas and two intermediate location areas.

Analysis of sixteen blocks in the Alamo Square area indicates that the dimensions of the generic block are preserved in only 18.75 per cent of intermediate lot locations. Of the others, 15.6 per cent are less than 137'6" wide and 65.65 per cent are wider than 137'6", demonstrating that lot subdivision was not bound by the dimensions of the generic parcel.

This analysis also found different depths for corner location areas. Only 41 per cent of the corner areas had the depth of the generic parcel; 59 per cent were smaller. The depth of individual lots in corner lot locations was reduced to increase the number of lots. Figure 11 shows the extension of the intermediate lot location area to the corners

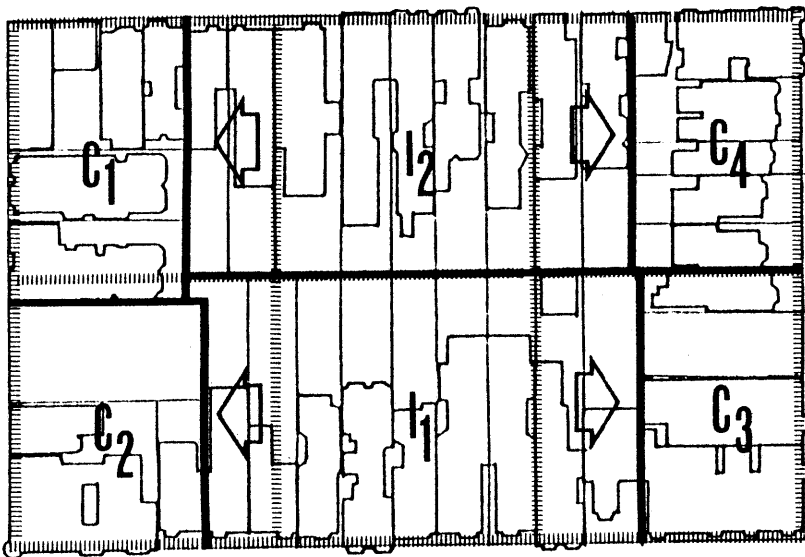

Fig. 11 Block 821 Location Areas of Lots



Fig. 12 Block 754 Golden Gate



Fig. 13 Block 777 Fulton

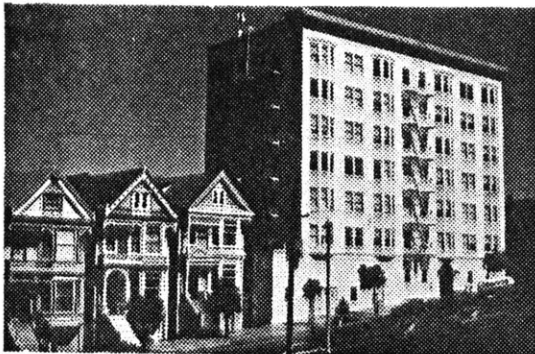

Fig. 14 Block 803 Steiner

and reduction in the depth of corner location lots in Block 821.

2.13

GENERAL DESCRIPTION ON THE BUILDING LEVEL

2.131

BUILDING TYPES; NUMBER OF FLOORS

The townhouse with one or two main floors was the dominant building type in the Victorian development. In 1899, only 24.14 per cent of the buildings had only one main floor; 66.79 per cent were two main floors high (Fig. 12).

During the last eighty years, there has been an increase in the number of buildings with three main floors. The percentage of buildings with one main floor has decreased to 15.53 per cent. This change is a result of decreasing family sizes as well as the trend of larger middle class families to live in suburbia where lots and houses are not as expensive as in the urban region.

A large number of apartment buildings have been built and provide many small units. Because of the building code regulation regarding density standards, these buildings usually have three main floors (Fig. 13).¹

¹San Francisco Municipal Code, Part II, Chapter II, Article I.

A few higher buildings can be found in this area, for example, a seven-story apartment building on Steiner Street. This building is located on Alamo Square which provides enough distance from structures on the opposite side of the square to permit a height of six main floors (Fig. 14)

In 1976, there were 1230 buildings in the surveyed area around Alamo Square of which only 27 (2.19 per cent) had more than 3 main floors.

2.132 TYPES OF PLOTS

The description of lot subdivision patterns in section 2.122 explains how lots of different widths and depths were generated. These lots contain buildings of varying types, dimensions, and shapes.

2.133 CORRELATION OF PLOT AND BUILDING

The interrelation of adjacent buildings is important for the morphological situation of the streetscape. Victorian development was based on two elements: lot size and the dimension and location of the building which covered the whole or a part of a site.

For a large number of streets, the elevation of built elements is not continuous. Buildings may

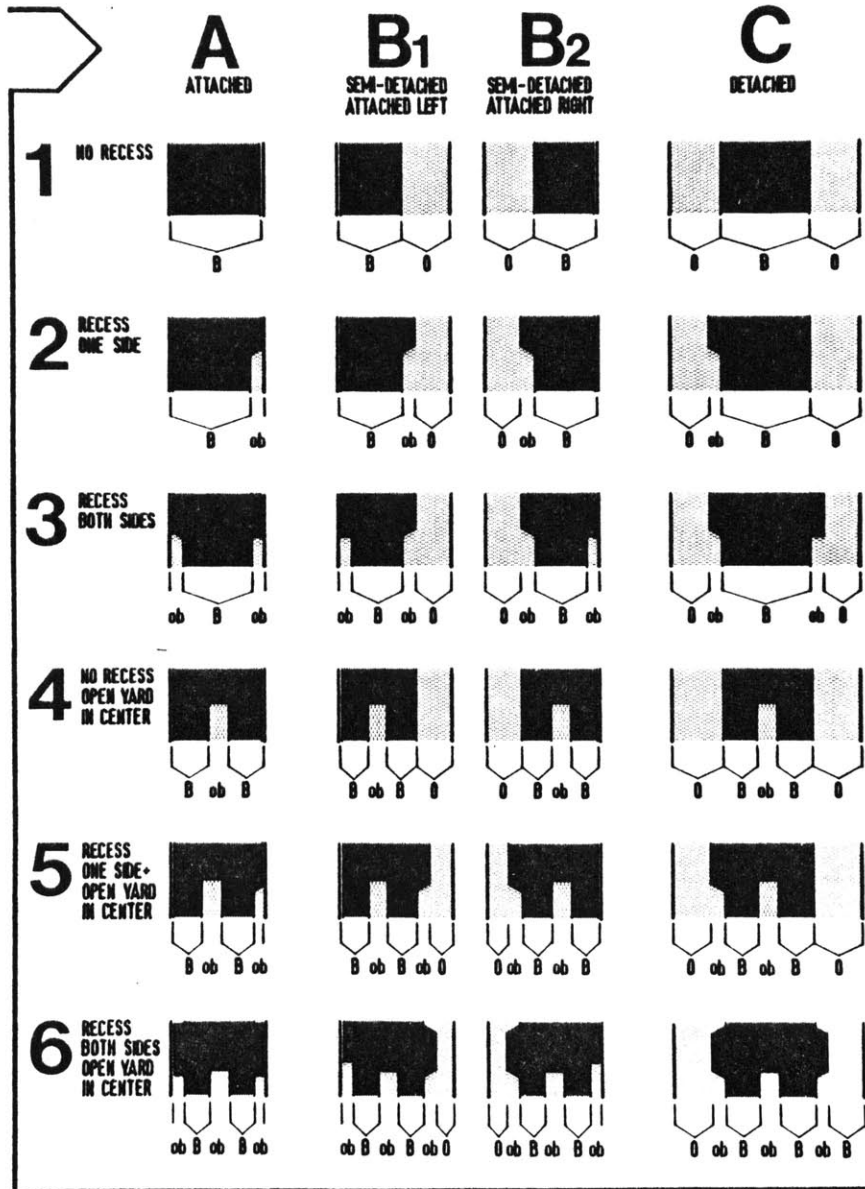

Fig. 15 Zoning Perpendicular to the Street

be semi-detached or detached. Some building types have recess elements on one or two sides (see section 2.142), an entrance yard in the center, or a combination of both. The location of the buildings, their dimensions, and the width of a lot generate a variety of arrangements.

Figure 15 shows how the plot-building correlation is perceived from the street. This scheme typologizes situations in intermediate location areas. A, B₁, B₂, and C regulate the position of a built element on a lot. Different forms of recesses, entrance yards, and their combinations are shown under numbers 1, 2, 3, 4, 5, and 6. The combination of these two elements generates a type of zoning system perpendicular to the street.

2.134 ELEMENTS OF BUILDING

The townhouse was the typical building type of the Victorian era. Although the number of apartment buildings has increased since the nineteenth century, only 16.7 per cent of the buildings in the surveyed area around Alamo Square are apartment buildings. Most buildings are townhouses. It is the townhouse which characterizes the streetscape.

Each townhouse dwelling can be differentiated by its separate elements which together form the complex environment, inside and outside, of each building. These elements are indicated in Figure 26. The base is the section of a building which adapts the building to the topography. The box, or main house, includes all major living and circulation spaces. The roof area tops the building. Add-ons in the front and back may increase the volume of the main house. Bay window elements in the front and along the side of a building are also specific elements of the Victorian townhouse.

2.1341
BASE

The base is one of the most interesting elements of a townhouse. Along with its function of adapting the rectangular box of the main house to the topography of the site, the base is the section of a building where public space, the street and sidewalk, ends and private space, staircases and the garage, begins. The most important functions of this semi-public zone are to provide access to parking space in the base area, pedestrian access to the building, and landscaping, if the building is set back from the street.

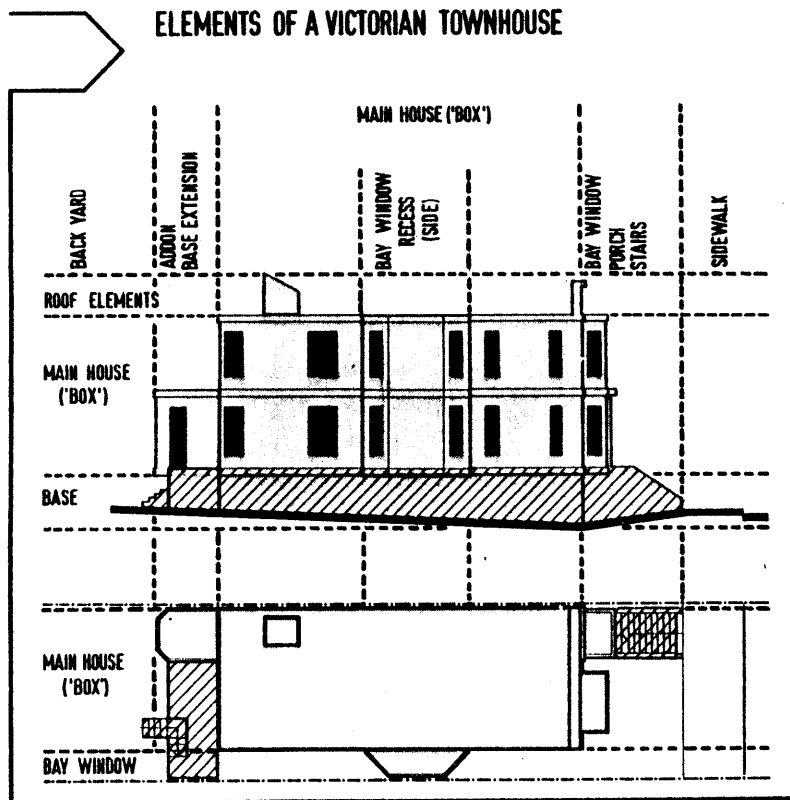

Fig. 16 Elements of the Victorian Townhouse — Base

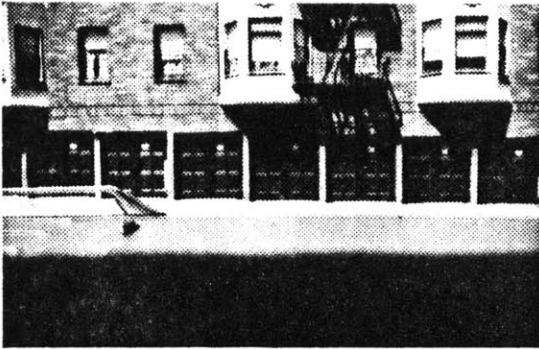

Fig. 17 Block 1154 B Scott

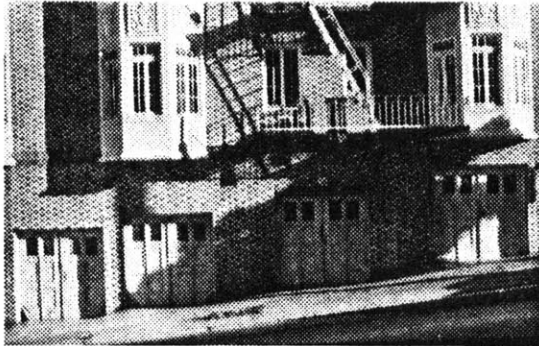

Fig. 18 Block 823 Hayes

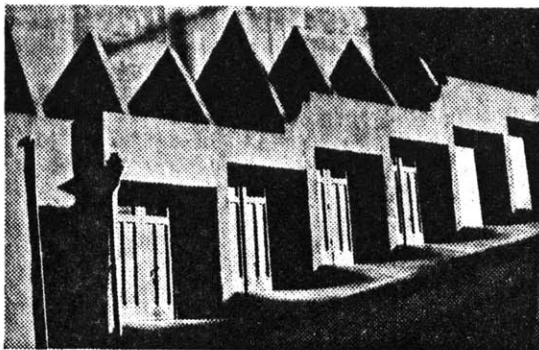

Fig. 19 Curb Cuts on a Very Steep Slope

In the generic Victorian streetscape, these different functions were heterogeneous (cf. Fig. 3). Staircase elements, front gardens, and curb cuts created a differentiated environment for this zone.

The trend to build apartment houses and convert townhouses into smaller units, coupled with the popularity of the car as an individually-owned passenger vehicle, required large amounts of parking space. Because streets do not provide all the required parking units, most base areas have become garages. The formerly differentiated base front has changed into a homogeneous wall in which garage doors are the dominant element. This provides a maximum number of separate accesses to individual parking spaces in the base, which now functions primarily as a container for cars. (Figs. 17, 18, and 19) The arrangement of continuous curb cuts limits parking along the sidewalk, does not permit landscaping, and reduces to a minimum the visual quality of this zone.

In the sidewalk area, a variety of open stairs provide access to buildings. These stairs may reach into the public zone (the sidewalk), as in Steiner Street, Block 826 (Fig. 20), or are a part

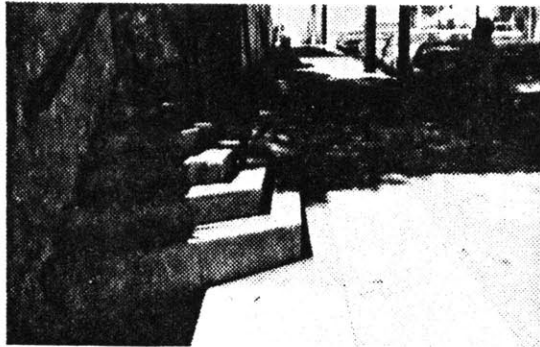

Fig. 20 Block 826 Steiner



Fig. 21 Block 826 Fell



Fig. 22 Block 819 Buchanan

of the landscaped, semi-public front zone, as in Fell Street, Block 826 (Fig. 21).

In other situations, they do not extend over the front lot line. Figure 22 shows a staircase elevation on Buchanan Street, Block 819. The steep slope and different heights of adjacent bases create stairs of different widths, directions, and depths. The base in this section of the street has a residential function. This means that additional staircases provide access to residential spaces located below sidewalk level. The entrance to these base-level residential areas is very often under the landing of the stairs, which provide access to the first floor.

Buildings with a very high base often have a staircase parallel to the street, inside or outside the building. Figure 23 shows a line of similar row houses with similar stairs, parallel to the sidewalk. Here, the base is used as residential

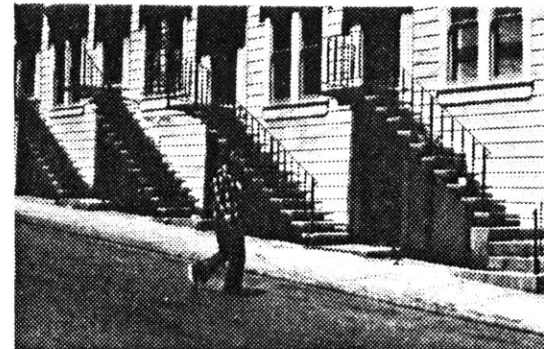

Fig. 23
Block 819 A
Linden

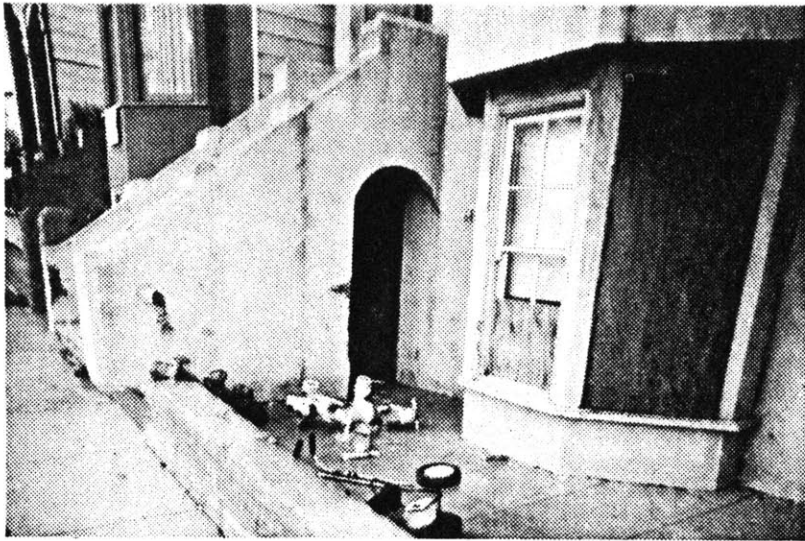

Fig. 24 Block 775 McAllister

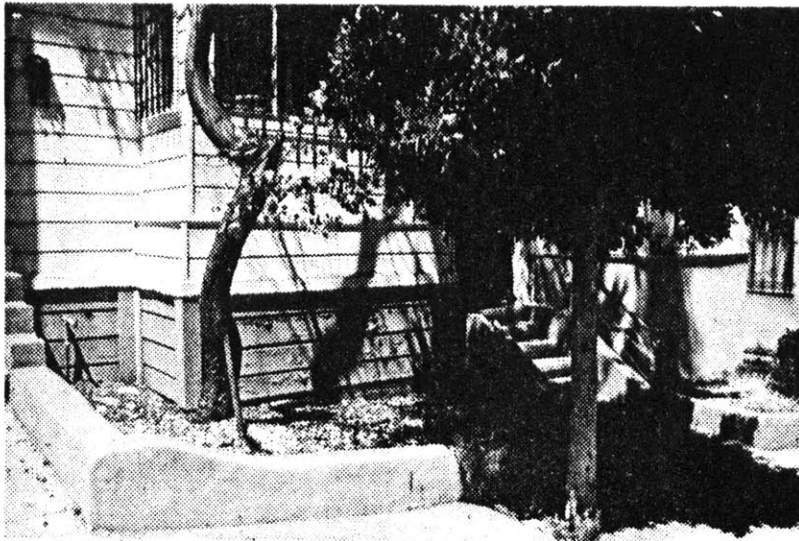

Fig. 25 Block 774 Golden Gate

space with its own entrance, located under the landing of the main staircase.

The zone between public sidewalk space and private building space may fulfill various "micro-functions" which do not dominate a whole street, but vary from site to site. To contain a function, the space in which this function occurs must be equivalent to the requirements of the function.

Differing set-back depths provide various possibilities of use for this area. While deep set-backs of more than fifteen feet create spaces which separate the public and private areas by an autonomous zone such as a front yard, set-backs with less depth generate a space with a different quality. A small set-back margin permits only minor activities or landscaping. Nevertheless, such an arrangement increases the attractiveness of the base zone for passing pedestrians and creates a variety of individual elements along a street.

On McAllister Street, Block 775, the ten-foot set-back margin contains elements for access to the first floor and base level of the main building, as well as a bay window (Fig. 24). The small set-back depth is not sufficient for a large playground, but large enough for a building-related playground for

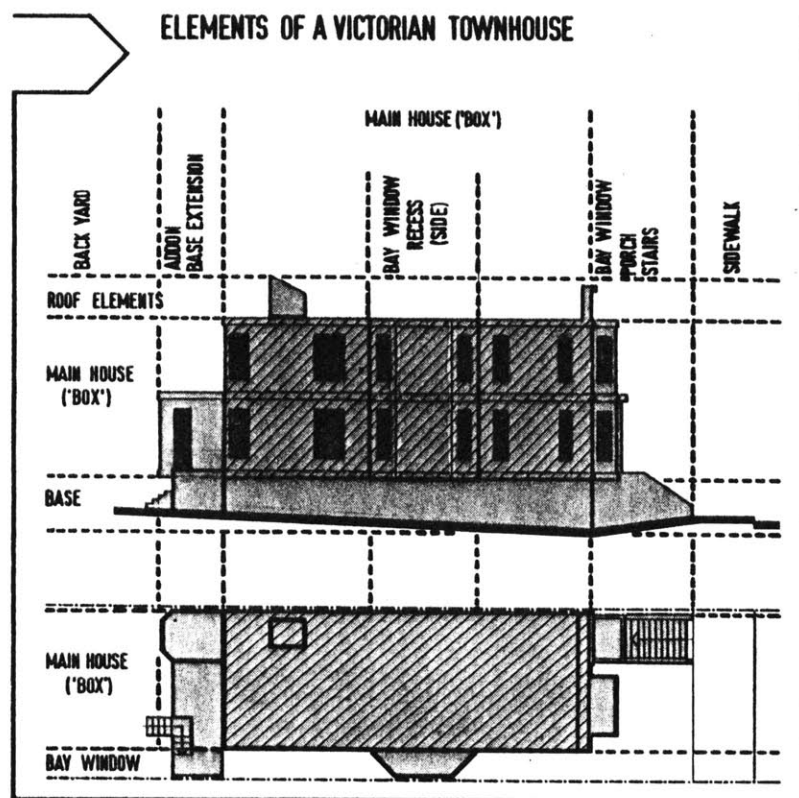

Fig. 26 Elements of the Victorian Townhouse
The Main House or Box

children, who exhibit a consciousness of the semi-public quality of this space by storing their toys behind the wall which separates this area from the sidewalk.

Minor set-backs, as shown in Figure 25 (Block 774, Golden Gate), also provide space for additional landscaping.

2.1342

MAIN HOUSE OR BOX

The main house, or "box", is the dominant element of a building (Fig. 26). The balloon frame construction method used creates a rectangular container for major indoor residential functions. This box is placed on the base, and accommodates up to three main floors. In 1899, only 0.43 per cent of all buildings had more than three floors. Even today, there are only 27 buildings (2.25 per cent) in the surveyed area of Alamo Square with more than three floors. These buildings are defined as non-thematic and will not be considered for the general analysis.

The box responds to the problems of maximizing the size of the house, providing enough light for the interior, and fulfilling constraints of the site dimensions and adjacent situations.

The floors of the Victorian townhouse were organized according to the "railroad plan," rooms are arranged along one side of a hall. The depth and width of each box may vary when adapted to more specific constraints of a site.²

The average ceiling height of the Victorian house is about eleven feet, high when compared to today's standard of eight to nine feet. This height provides very good lighting for the interior and permits deep rooms.

2.1343 ROOF

The roof area of a building contains built elements of residential or technical use (e.g., a chimney). A roof area is defined as the space located at the top of a building which has no prior formal relation to the front facade. Victorian buildings exhibit a very differentiated roofscape on some streets, created by various elements of the style and their interrelations. New buildings generally do not fulfill this criterion. Recommendations will be proposed which assimilate this characteristic for new designs.

2.1344 ADD-ONS

The main house is a container for basic indoor housing functions. Specific requirements of the dweller often necessitate ex-

²For detailed information on the characteristics of floor plans for dwellings and flats, see the report, "Urban Form and Change."

expansion of the space provided by the box. It is possible to add extra space to a dwelling by attaching add-ons to the dwelling.

Most add-ons are attached to the back of a building, where they may be attached along the complete height of the building. When townhouses are converted to flats, add-ons are usually built on the back, to provide an additional kitchen or bedroom.

Add-ons are not attached to the main floor area on the front of a building. Additional built elements in the front of a box are located only in the base area, to provide additional parking space. For commercial use, an add-on may extend into the first floor space, to provide a second level for a shop or an office.

2.1345

CHARACTERISTICS OF THE VICTORIAN RESIDENTIAL BUILDING

The bay window is not an architectural element specific to the San Francisco area, but it is used there in a very unique way and has a strong importance in the elevation fabric of the street.

Bay windows amplify lighting and view for rooms along the front facade. Although they occur only occasionally along the back of existing buildings, they dominate the front (in corner locations, though, only along the street-oriented sides) and cover part of the space which lies between the public space, the street and sidewalk, and the private space, the main house or box.

Bay windows produce a set of vertical volumes in front of boxes and create, with entrance porches, staircases, and entrances, a breakdown in the continuity of these boxes. While different set-



Fig. 27 Block 822 Steiner



Fig. 28 Block 822 Steiner



Fig. 29 Block 778 Fulton

back depths modulate the street elevation in the box scale, bay windows divide the mass of a single box into a set of smaller elements.

This system of breaking down the continuity of front facades along the street elevation generates two levels of depth. Major differences in depth are produced by the set-back of a building, up to twenty feet, while a rhythm of more shallow variations, from two to five feet, is created by bay windows of different sizes and shapes (Figs. 27, 28, and 29).

Shapes of the Victorian bay windows differ, according to the style in which the building was built. Stick Style preferred rectangular bay windows. Queen Anne Style buildings have round bay windows. The Italianate Style placed the sides of bay windows at an angle of thirty to sixty degrees to the front facade.

The width of these elements varies from seven to ten feet. Post-Victorian styles and a large number of blended styles assimilate the bay window but change dimensions and materials. The San Francisco Building Code regulations limit bay window depth in relation to the width of the adjacent sidewalk, resulting in a shallow but wider type of bay window (Fig. 28)

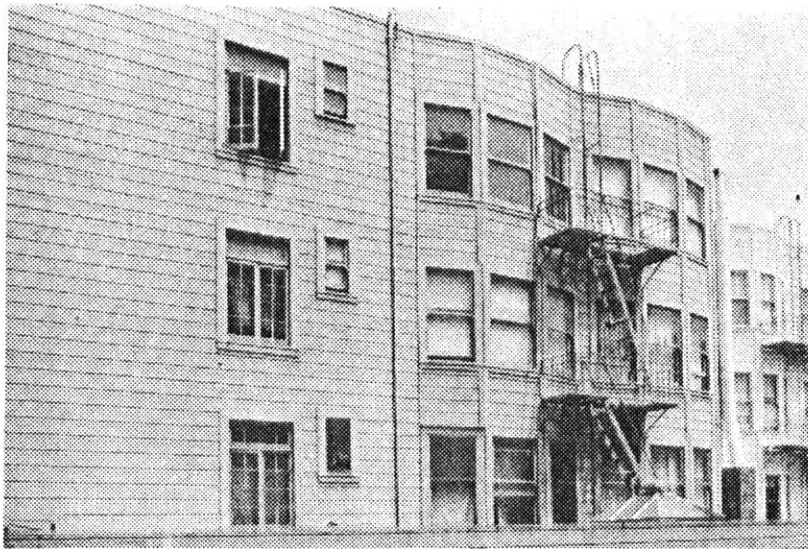

Fig. 30



Fig. 31

Bay windows are located on the side as well as the front of a building, according to the location of a building and the decision of the builder.

The surface area where special concern is placed on the design and ornamentation of the facade is called the public facade. This is the outside of the box, the envelope of the private space, which faces the public and represents the dweller's individual taste to the public. Elements in the public facade area display a rich vocabulary of styles and ornamentation, while the rest of the envelope is very simply treated. Figures 30 and 31 show simple construction of the back of two Victorian buildings which have very ornate front facades. In these cases, the bay window elements are repeated in the back.

The balloon frame technique permitted mass production of houses. A large variety of prefabricated details was available for ornamentation of public facades. Armed with pattern book and architectural catalogues,³ even an unimaginative builder could create a dwelling which we find today amazing.

³An example is Architectural Elements, The Technological Revolution. (Princeton: Pyne Press.)

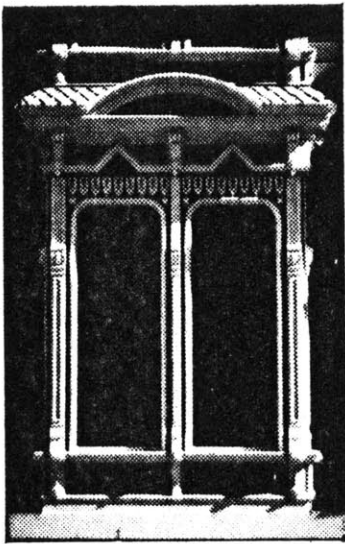

Fig. 32 Block 1179
McAllister

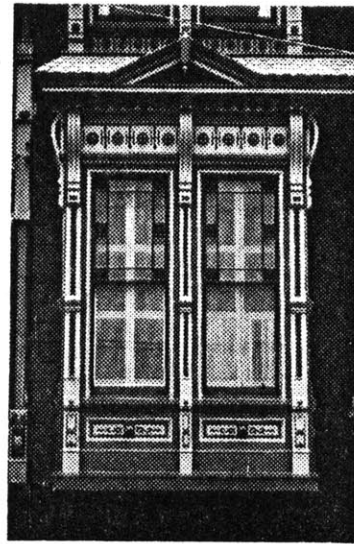

Fig. 33 Block 777
McAllister

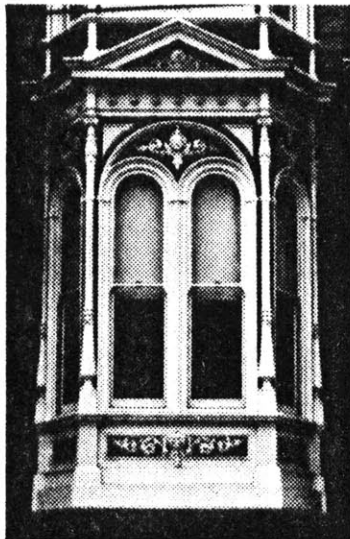

Fig. 34 Block 777
McAllister

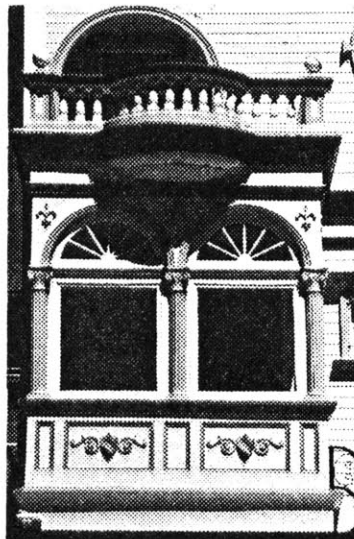

Fig. 35 Block 798
Steiner

Brackets, spindles, decorative shingles, oriels and bays, sawn wood ornaments, verge boards, tiles, etched and stained glass, incised ornament, appliques, soaring chimneys – there were literally hundreds of design variations and materials that the Victorian builder could use to make a house "beautiful" – and distinctive from others in the same architectural style.⁴

A few examples of such ornamentation for bay windows are presented in Figures 32, 33, 34, and 35. Although these examples are based on the same construction dimensions, they differ in shape and detail.

The bay of the McAllister, Block 1179, example (Fig. 32) is based on the Stick Style which preferred a rectangular shape of bay window element (squared bays) and emphasized the bay by decorative strips. Wooden ornaments over the windows are based on the Italianate Style.

The building on McAllister, Block 777 (Fig. 33) is another example of the Stick Style with Victorian Gothic ornamentation. The sawn wood elements are very colorfully painted, and the windows are decorated with stained glass.

⁴Judith Lynch Waldhorn, *A Gift to the Street*. (San Francisco: Antelope Island Press, 1976)

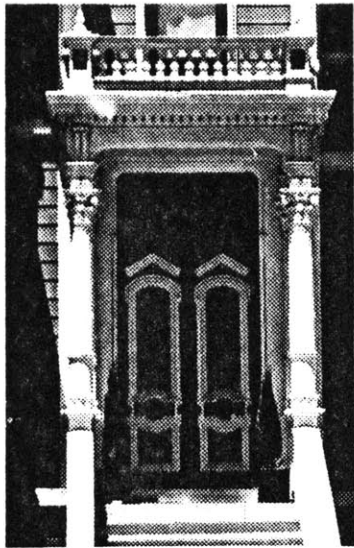

Fig. 36 Russian Embassy



Fig. 37 Block 1179 McAllister



Fig. 38 Block 777 McAllister



Fig. 38 Block 1155 Golden Gate

Figure 34, McAllister, Block 777, shows a slanted bay with pipe stem colonnette at the edges, a typical representative of the Italianate Style.

While Figures 32, 33, and 34 show an emphasis of vertical elements with high and narrow window segments, the windows in Figure 35 are nearly square. This example, from Steiner Street, Block 798, represents a blend of styles. The shapes of the bays are based on the Stick Style, while the window forms and ornamentation are rooted in the Colonial Revival Style.

Porches, as well as bay windows, are treated as elements of the public facade. They display the same basic formal elements, but very often have additional ornamentation. Figures 36 and 37 show columns supporting the balcony over two entrances. The capitals of these cylindrical elements are richly ornamented with acanthus leaves, derived from the Corinthian order.

Ionic columns decorate the porch in Figure 38, while columns in Figure 39 are rooted in romanesque patterns. These two porches emphasize their importance as representative architectural elements with additional elements such as the putto in the arch or colorful sawn wooden ornamentation based on an Islamic design.

Variations in ornamentation, especially, made a single building distinctive and generated the individuality of each public facade, constrained by construction dimensions and basic styles.

2.14 CORRELATION OF BUILDINGS

The description of criteria for single buildings demonstrates the variety of individual built elements in the urban block tissue. This phenomenon is not unique to San Francisco. The extremes of the topographical situation, combined with the street grid, are specific to this area and create morphological relations of built elements which can be found only here.

2.141 THE BASE AREA

The base area displays not only differentiations in access patterns and set-back dimensions, but also in the correlation of building size and plot width (cf. section 2.133). A bay window at the side of a building generates a recess which interrupts the continuity of the front facade elevation. Such recess elements create a type of ob-margin perpendicular to the street. An opening between two buildings (Fig. 40) can provide access



Fig. 40 Block 825 Fell

for parking in the rear yard, be a side yard, or provide additional pedestrian access to the side. Such side clearances are generated by the location of a building on a wide lot.

A building may be detached or semi-detached in relation to neighboring buildings, generating one or two O-zones perpendicular to the street.

Combinations of ob-margins and O-zones are also possible. An example of an opening for vehicular circulation, in the base area under the main floor area, is shown in Figure 41.

2.142

MAIN FLOOR AREA

Adjacent main floor areas may differ in dimensions of width and height, in types of bay windows, and in ornamentation. According to the location of a building on a lot, main floors have the same position patterns as bases (attached, semi-detached, or detached) and generate the same ob-margins or O-zones on the main floor level. Depending on the top of the base, with different heights for each building in a sloping situation, the height of main floors also varies from building to building. Buildings step with the slope which generates different levels for the same

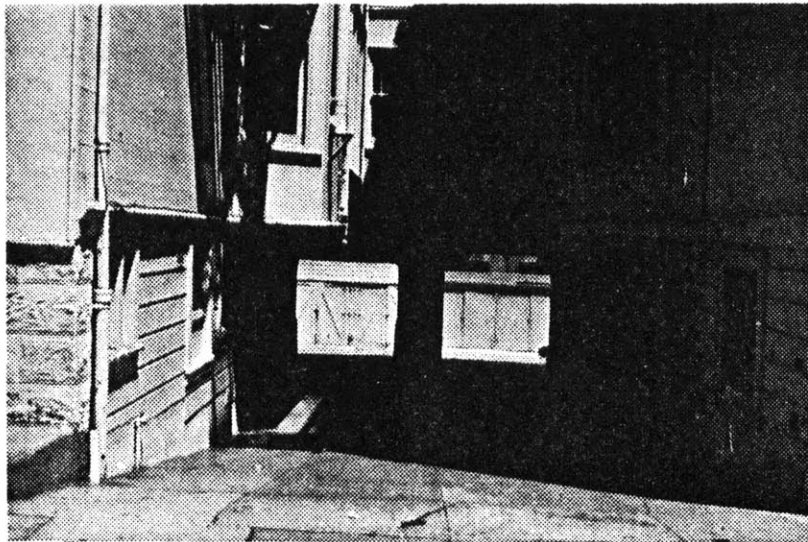

Fig. 41 Driveway Under a Recess



Fig. 42 Block 820 B Fell



Fig. 43 Block 778
Fulton

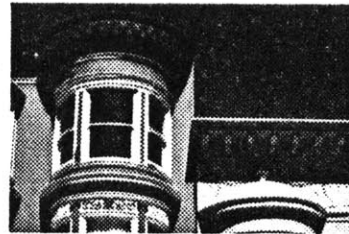

Fig. 44 Block 827
Steiner



Fig. 45 Block 822
Steiner

floor in adjacent buildings (Fig. 43). Normally, buildings step parallel to a slope, but it is also possible that the stepping moves against the slope, if the number of main floors differs from one building to the next (Fig. 42).

2.143 ROOF AREA

In the roof area the same correlation criteria as in the main floor can be seen. Roofs step with the slope; they differ in cornice height. As well as this variation, they break the continuity of the roofscape by different shapes of such elements as cornices and gables.

Figure 44 (Steiner, Block 827) shows the roof detail of two attached buildings. Although they have the same number of main floors, they differ in height because of the steep slope and different base adaptations.

Figure 45 is an example of how different cornice heights and roof shapes create a variety of forms on the roof level.

2.15 FORMAL CHARACTERISTICS OF THE STREETScape

A survey analyzed the streetscape of fifty blocks in the Alamo Square area. Although there



Fig. 46 Webster Street



Fig. 47 Block 776 Golden Gate

was a continuity of set-backs, recesses, and the change of house type patterns in most streets, some sections indicated a very strong similarity of elements.

Similar row houses along a section of Webster Street (Fig. 46) are all located with their front facades at the sidewalk. Each building has the same width (25', 7.5 m). Bay windows have the same proportions; every other building has the same roofing ornamentation on the top bay window. Individual buildings differ only in color and ornamentation.

In comparison, a group of buildings along Golden Gate, Block 776 (Fig. 47), has the same height, access patterns, location and width. Each single unit is detached from adjacent buildings, with the same distance between each one. Even the bay windows resemble each other in shape and location on the facade. These buildings differ in color, ornamentation, facade material, and in details of roof elements.

These two examples present situations where the generic parcels were subdivided into lots of equal size, and these lots were developed by the same builder. One group exhibits more variation.



Fig. 48 Block 803 Steiner



Fig. 49 Block 1215 Oak

Another development example is the complex of houses along Steiner Street at Alamo Square (Fig 48). This ensemble was constructed from the same floor plan by the carpenter/builder, Matthew Kavanaugh around 1895. Each building has a unique ornamentation on the front facade, but exactly the same location for bay windows, balconies, and porches. The charm of this ensemble is the slight difference of gable ornamentation, porch balusters, and coloring.

The examples shown in Figures 46, 47, and 48 are not typical of the area in general, but they visualize well the influence of the individual on buildings built at the same time. Variations in the buildings on Golden Gate were spontaneous, generated by the dwellers. Variations in the ensemble along Steiner Street were planned by one person, but are based on prefabricated architectural parts offered by the building industry in the nineteenth century.

In contrast to these homogeneous groups of structures, heterogeneous groups may be found in this area. These buildings differ not only in size, style, and material, but serve different functions as well (Fig. 49).

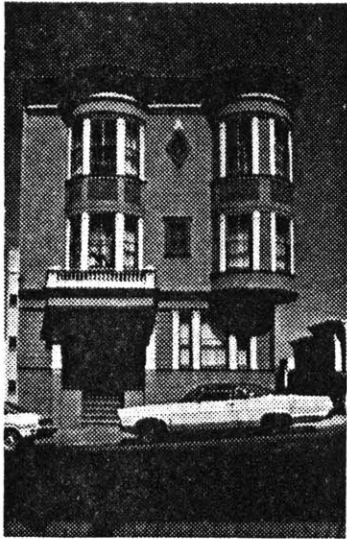

Fig. 50 Block 829
430 Webster

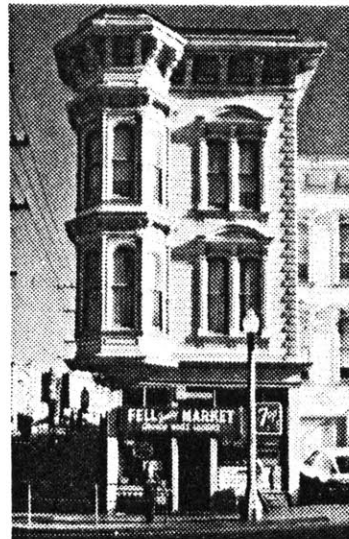

Fig. 51 Block 830
Fell/Laguna

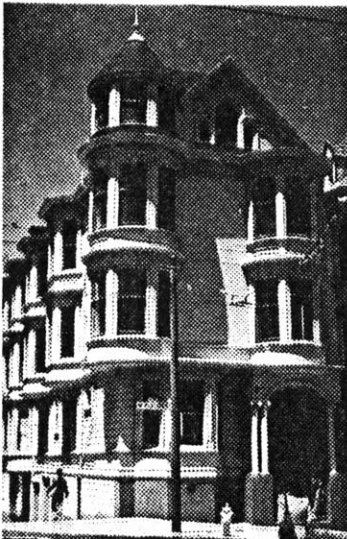

Fig. 52 Block 775
McAllister/ Pierce

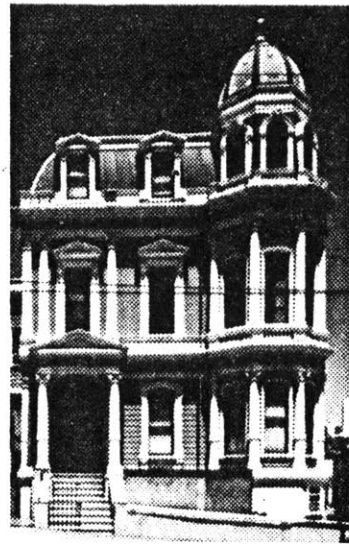

Fig. 53 Block 805
Hayes

As well as emphasizing corner locations with apartment buildings (see section 2.131), the generic Victorian streetscape includes specific corner elements. The most common method of emphasizing a corner was to orient a bay window to both sides, creating a 270 degree bay. Figure 50 shows a situation on Webster Street, Block 829, where a round bay window wraps around a corner. Victorian styles also emphasized the corner element with cornice ornamentation, as in a building at the corner of Fell and Laguna Streets, Block 830 (Fig. 51). In other situations, such as the corner of McAllister and Pierce, Block 775 (Fig. 52), and the corner of Hayes and Buchanan, Block 805 (Fig. 53), corner location is emphasized by round corner towers.

This description of different morphological elements and their correlations is only a brief summary of the complex morphology around Alamo Square. More detailed information will be provided in the report, "Urban Form and Change." Nevertheless, this study documents the basic elements of the tissue and indicates tissue patterns.

This study does not include an evaluation of these morphological situations. Historians, planners, environmental psychologists, sociologists,

and economists would be needed to evaluate this situation in its entire complexity. For the further development of new tissue rules, these major patterns will be taken into consideration.

2.2

CHANGE WITH(OUT) LOSS – RENEWAL AND RESTORATION PROJECTS AROUND ALAMO SQUARE

2.21

PROBLEMS OF URBAN CHANGE

The flexibility of an urban tissue can be measured by its capacity to permit changes which adapt the structure to modern requirements. These newly created necessities may be the result of differing life styles or the demands of additional functions. The change of an urban environment is a physical change. Buildings may be extended, renovated, and torn down, to be replaced by new ones.

The Victorian block tissue contains elements which permit this kind of permanent regeneration. The subdivision of lots into small plots and individually-owned single units enable change on a small scale.

Today, more and more land is owned by fewer individuals. This means that sites can become larger, as large as a whole block. Change is not any longer a matter of a group of house-owners, but becomes a project, which must maximize profit for a small group of financiers who have little or no interest in the living quality of the area or concern for the architectural adaptation of a new design to an existing situation.

While change in a living environment takes a certain amount of time – in the Alamo Square area, the change from houses to



Fig. 54 Block 778 Fulton Street (1910)



Fig. 55 Block 778 Fulton Street (1977)

flats took eighty years and is still an ongoing process – new building materials and methods produce rapid change on a large scale, sometimes in only a few months. Very often, new developments have not only economic and construction-related constraints, but are built in a popular design fashion which can be defined as modern but has little or no respect for the formal context of the neighborhood.

The change in a single block element, a building, can be minor. Figures 54 and 55 show two houses of the same type on Fulton Street, Block 778. The upper picture shows these two houses in 1910.⁵ They are smaller than their lots and leave a ten-foot (3 m) side clearance between them. They have public facade ornamentation on the front only, and ornamented gables over the roof-story windows.

The second photograph presents the change after sixty-five years. The main elements of these dwellings have not changed. The ornamentation on the gables has been removed, and the finish on the front facades has been simplified (perhaps under the influence of the International Style). A change of functions for main floor areas cannot be

⁵San Francisco Historical Society Photo Collection.

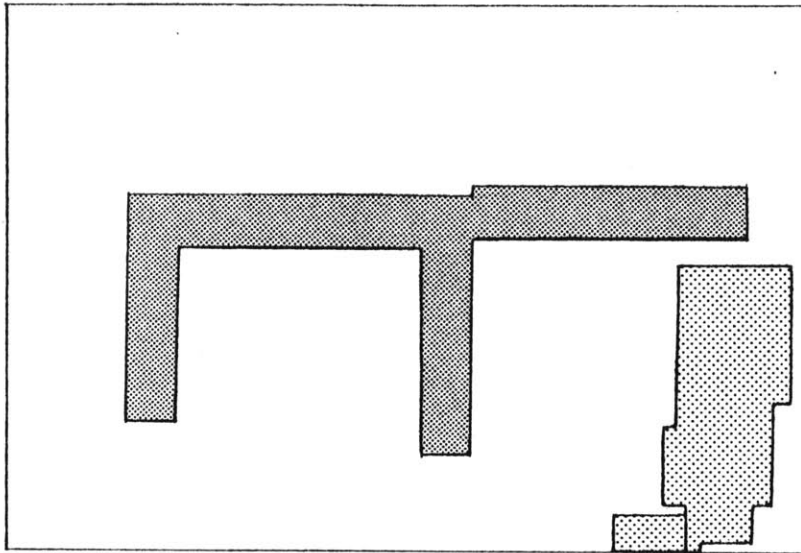

Fig. 56 Block 757 (1976)

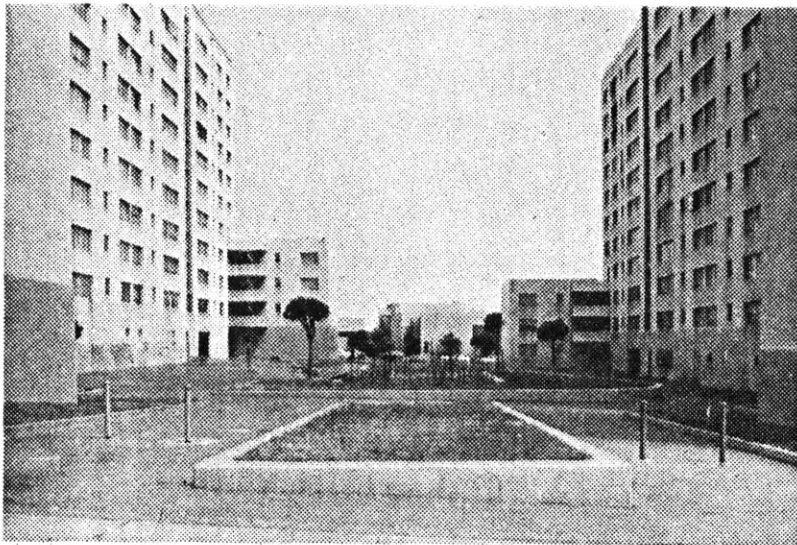

Fig. 57 Courtyard

inferred from these photographs, but one can see that part of the base of the house on the right has been converted to a garage.

2.22 NEW DEVELOPMENTS

Modern standards of housing, construction methods and technology, and architectural trends will influence the form of future block tissues. They can either ignore existing life styles and architectural morphology or adapt new designs to the existing situation by assimilating the most characteristic elements of the surrounding environment.

Block 757 was subdivided into twenty lots before 1931. In contrast to most residential lots, this block contained fifteen non-residential functions and only thirty-three residential units. The existing physical structure of this block was torn down for a new development, which gave 211 families



Fig. 58 Elevation

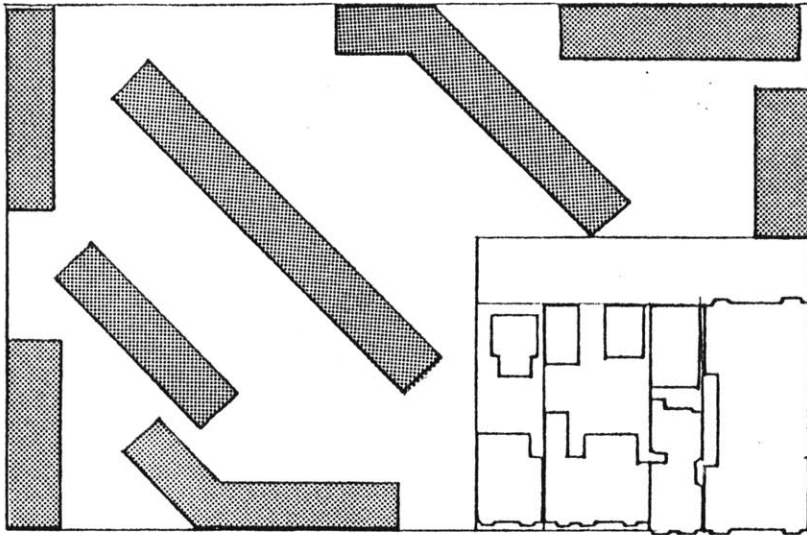

Fig. 59 Block 802 (1976)

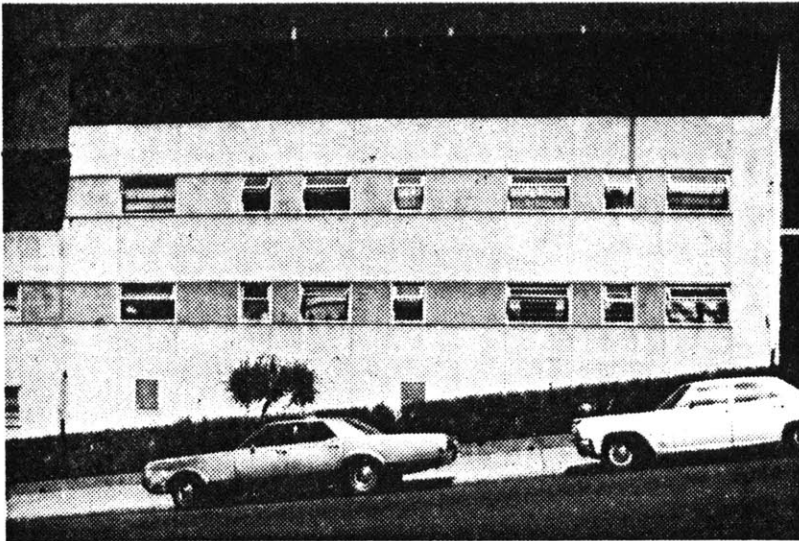

Fig. 60 Block 820

a home and reduced building coverage to 18.4 per cent. (Figs. 56, 57, 58)

The public housing project in Block 820 is a low rise development (Figs. 59, 60). Three open building blocks, arranged diagonally to the existing built element layout, provide two inner courtyard zones used for parking. Facades on the street are continuous and ignore all formal aspects of the neighborhood (Fig. 60). Figures 61 and 62 show two other developments, a low rise type in a schematic set-back layout (Fig. 61), and one with more differentiated breaks in the continuity of the facade. (Fig. 62)

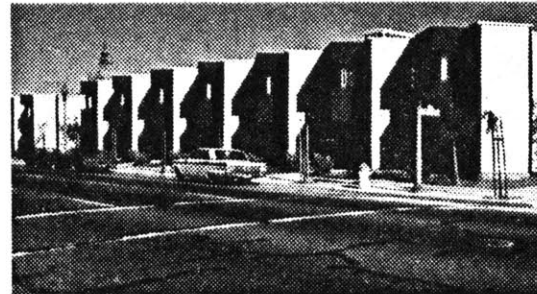

Fig. 61
Block 748
Turk



Fig. 62
Block 780 52

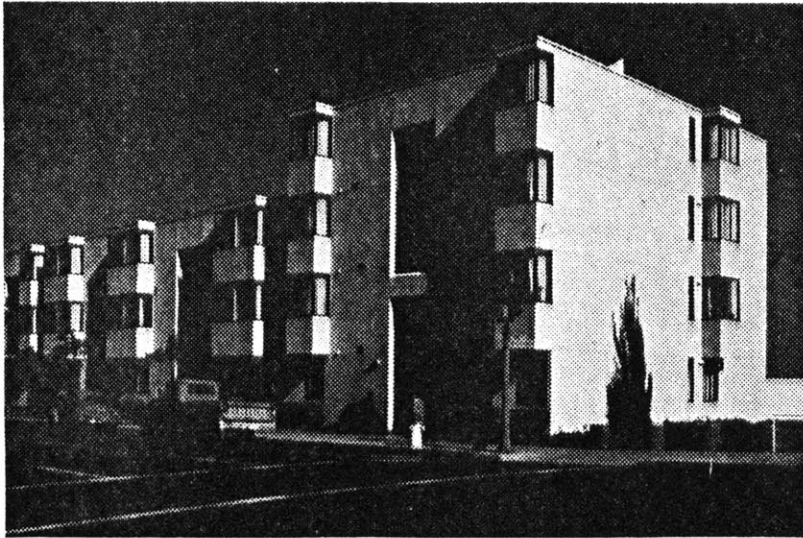

Fig. 63 Block 1079 Golden Gate at Buchanan

Several approaches to the assimilation of formal elements of the block tissue can be seen. A public housing project at Golden Gate, near Buchanan, increases the height of the building by one floor at the corner locations. Window elements are organized as bays on the front of the main facade. Large vertical openings for staircases repeat the vertical rhythm which dominates the Victorian streetscape (Fig. 63).

Figures 64 and 65 provide other examples of new structures in corner locations. The corner is treated differently in each design. A tower construction (Fig. 64) and a corner bay (Fig. 65) give this part of the building a specific accent.



Fig. 64 Building with Tower to Emphasize Corner

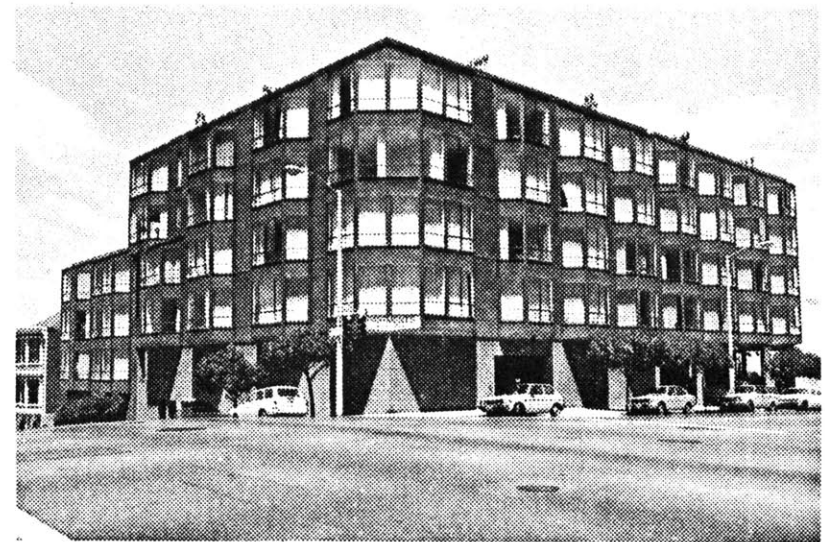

Fig. 65 Building with Bay to Emphasize Corner

2.23

ARCHITECTURAL GROUPINGS FOR MAPPING PURPOSES

The San Francisco Planning Department is conscious of the unique Victorian residential areas. Their efforts are concentrated not only on sections of the Western Addition, but in other districts of San Francisco which have a built environment worthy of preservation. An analysis has been made on the individual house, as well as the regional (zoning), level. The important elements of the building types were classified and their positions relative to the sidewalk notated (Fig. 66).

A survey of styles of the Victorian streetscape in other parts of San Francisco was considered as well. Figure 67 shows a list of the various styles which occur in the city region. The five main groups, California Tradition, Nineteenth Century Ornamental Styles, American Traditional and Regional Styles, Classical Root Styles, Exotic Styles, and Modern Root Styles, can be divided into sub-styles and mixtures of these sub-styles.

Buildings along a street are evaluated according to certain criteria regarding their relationship to adjacent buildings and their architectural design. The evaluation form presented in Figure 67 contains information about the general condition of



Fig. 66 Street Elevation with Analysis of Set-Back Zone

ARCHITECTURAL GROUPINGS FOR MAPPING PURPOSES
(Proposed March 4, 1976 - amended as below)

Final Version

A. California Tradition

1. Mission
2. Mission Revival
3. Pueblo Style
4. Spanish Colonial Revival
5. Monterey Style
6. Variations

B. Nineteenth Century Ornamental Styles

1. Gothic Revival
2. Greek Revival
3. Italianate/Italian Revival
4. Stick Style/Eastlake
5. Queen Anne
6. French Mansard
7. Carpenter Classic/Edwardian
8. Compromised: Amalgam, Vernacular, Romeo, Related

C. American Traditional and Regional Styles

1. First Bay Tradition
2. Second Bay Tradition
3. Third Bay Tradition
4. Colonial Revival
5. Craftsman/Bungalow
6. Related/Unornamented Vernacular

D. Classical Root Styles

1. Beaux Arts/Neoclassicism/late Greek Revival
2. Free Classical
3. Renaissance
4. Romanesque
5. Skyscraper Gothic
6. Georgian
7. Vernacular Variations

E. Exotic Styles

1. French Baroque
2. Art Nouveau/Secessionist
3. Flemish Baroque
4. Tudoresque/Jacobethan
5. Cottage Styles
6. Moorish/Oriental Styles
7. Miscellaneous/other Revivals; German Baroque, Byzantine Revival

F. Modern Root Styles

1. Commercial/Utilitarian
2. International/Miesian
3. Prairie School
4. Formalism
5. Zig Zag Moderne
6. Streamline/W.P.A. Moderne
7. Expressionist/Structural Exhibitionist/Brutalism
8. Related Variations

Fig. 67

(814-16) 18 Fall

street address 822 block number 10 lot number 3 summary

building type/use/number of floors R.3 landmark number

RELATIONSHIP WITH SURROUNDING BUILDINGS

Relationship of setting to building -2 -1 0 1 2 3 4 5

Importance as contribution to a cluster/streetscape -2 -1 0 1 2 3 4 5

ARCHITECTURAL DESIGN VALUATION

Facade proportions -2 -1 0 1 2 3 4 5

Richness/Excellence of detailing/decoration -2 -1 0 1 2 3 4 5

Unique visual feature of interest 0 1 2 3 4 5

Example of a rare or unusual style or design 0 1 2 3 4 5

Overall architectural quality -2 -1 0 1 2 3 4 5

PROPOSED FOR FURTHER INVESTIGATION

CORNICE, PARAPET, APPENDAGE

Importance of cornice to building design -2 -1 0 1 2 3 4 5

Cornice contribution to streetscape -2 -1 0 1 2 3 4 5

FACADE CONDITION

Physical condition -2 -1 0 2 3 4 5

Paint/Material color -2 -1 0 1 2 3 4 5

REMODELING

Appropriateness of improvements -2 -1 0 1 2 3 4 5

Engl. 8-27-76
date

Field Notes

Review Notes

- Junior League Listing
- text index file
- Northern California Guide
- Other Listing _____



Fig. 68

a building, and a photograph. This method is being applied to thousands of buildings which are located in renewal districts. (Fig. 68)

2.24

THE SAN FRANCISCO REDEVELOPMENT AGENCY

An interesting effort to restore the Western Addition is being made by the San Francisco Redevelopment Agency (SFRA). Working with the San Francisco Department of City Planning, this agency gives advice to property owners, potential property owners, and tenants with building rehabilitation problems. Revitalization work of the SFRA is concentrated in the A2 district of the Western Addition, where more than 2,600 dwellings of architectural, historical or visual merit have been included in a restoration program.

The SFRA offers low-interest loans for rehabilitation of houses and apartments. Property owners may borrow up to \$30,000 per dwelling unit for rehabilitation and refinancing of up to eight per cent of the post-rehabilitation value. These thirty-year, low-interest loans are made possible by the Marks-Foran Act of California. Under this program, banks lend money for rehabilitation to the SFRA at five to six per cent interest. The SFRA makes loans to property owners, and services these loans for only an additional three-quarters of a per cent.

This financial aid is provided for preservation of buildings. Generally, single buildings are bought and restored by the SFRA.

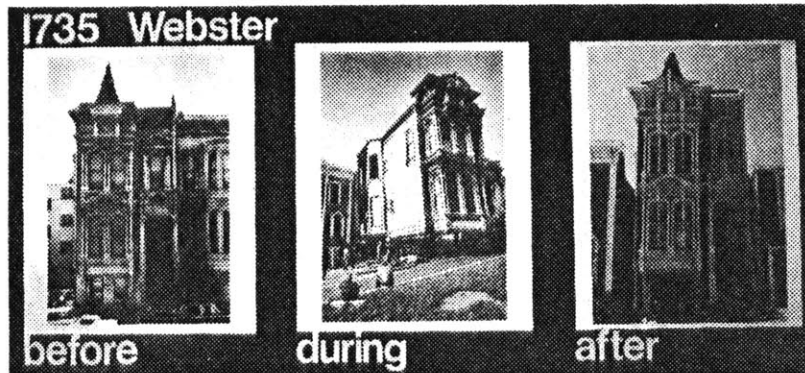

Fig. 69

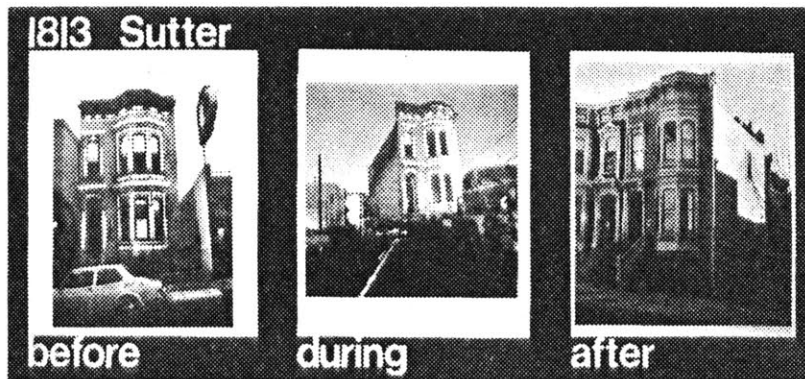

Fig. 70

If necessary, buildings may be moved to other sites. (Figs. 69 and 70)

Each restored building must fulfill new housing code requirements for protection against fire and earthquakes by the installation of a sprinkler system and special site preparation and base construction.

Floor plans and circulation elements are often changed and additional spaces added to the built envelope, depending on the specific location of the building on the site. Although efforts are made to restore the Victorian interior, the preservation of the public facade is considered the most important goal of restoration. The final result is usually a sensitive conservation of Victorian architectural heritage, combined with an interior conversion to modern standards.

Total costs of such a project (moving and rehabilitation of a townhouse), including the price of the site and any buildings on the site, may be as much as \$200,000, an investment of \$100,000 per flat.

As well as restoring single buildings and their infill, the SFRA is revitalizing a large section along Sutter and Filmore Streets called Vic-



Fig. 71 Victorian Square from Fillmore

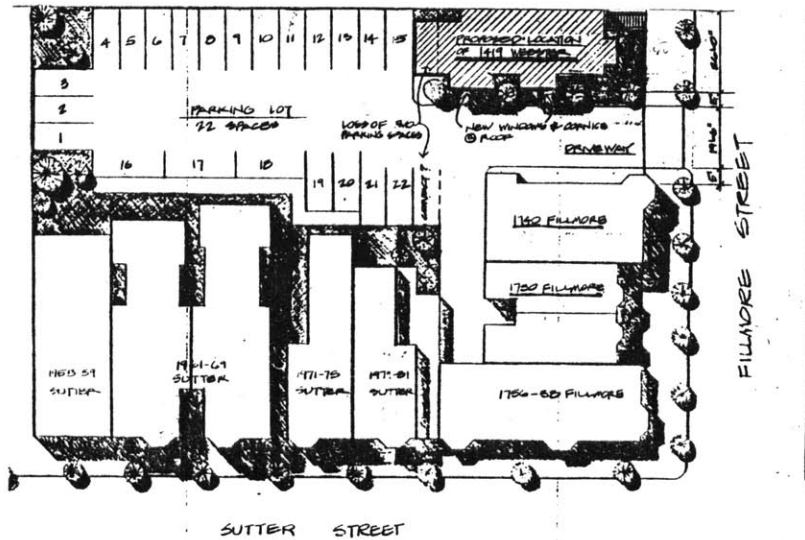

Fig. 72 Site Plan for Victorian Square Redevelopment

torian Square. Ten Victorian buildings are being moved to this location where they are being renewed. (Fig. 71) These buildings are located on the site in the patterns of set-backs and orientation of the public facade of the Victorian streetscape. These buildings will contain spaces for both commercial and residential use. Because the base area will be used for shops and offices, parking must be provided in the rear. (Fig. 72)

This kaleidoscopic description of urban change around Alamo Square indicates the different levels of urban renewal. Some of these projects consider the unique tissue and architectural elements of the area, others ignore them.

After a period of building projects with no consideration for existing tissue patterns (Blocks 757, 796, and 820 contain good examples of this), planners and architects have begun to appreciate the value of the Victorian environment. Efforts such as the mapping program are helping analyze the architectural value of streetscapes. Groups such as the Foundation for San Francisco's Architectural Heritage and the San Francisco Redevelopment Agency are helping conserve important elements of this environment. New regulations assure the

adaptation of future developments to the scale of existing buildings. It will be necessary as well to build, with current materials and practices, new developments which fulfill the requirements of the new building code.

If the change of the built environment is seen as a continuous process, with regards to patterns of the existing urban situation, application of a method which allows such consideration will be important. SAR 73 can be such a tool. In the following sections, this method will be applied to analyze the tissue and develop a proposal of regulations. To understand the characteristics of this method and its notation system, section 2.25 provides an introduction to SAR 73 and defines specific terms and their notations.

2.25

SUMMARY: SAR 73, THE METHODICAL FORMULATION OF AGREEMENTS CONCERNING THE DIRECT DWELLING ENVIRONMENT.

CONTENTS: 2.251 General Comment
 2.252 The Method
 2.253 Elements
 2.254 Functions
 2.255 Notations of Agreements
 2.256 Documents and the Tissue Model
 2.257 Application of the Tissue Model

2.251

GENERAL COMMENT

The analysis of the San Francisco study is based on SAR 73,⁵ a methodical notation system for the design of urban tissues. This method will be applied to develop and evaluate tissue models of San Francisco's Alamo Square. To understand its characteristics and possibilities, the method will here be briefly explained, specific relevant criteria will be stated, technical terms will be defined, and a graphic notation system for presentation will be demonstrated.

2.252

THE METHOD

An urban settlement or quarter may show certain patterns in

⁵Stichting Architecten Research, SAR 73, The Methodical Formulation of Agreements Concerning the Direct Dwelling Environment.

the arrangement and correlation of built elements, open spaces, and circulation systems for pedestrians and vehicles. Such a situation may be called a tissue. A tissue exists if there is repetition in the relation and braiding of built elements and open space. If such repetition exists, we call the dwelling environment a tissue.

Various examples of tissues may be found in different urban settlements such as the medieval town of Elburg, built between 1393 and 1398; the workers' settlement, "Cité Ouvrière," in Muelhausen, France, built around 1875; or, on a larger scale, parts of large towns which were developed during the Industrial Revolution (e.g., the expansion of Barcelona, Berlin, and Vienna). These tissues are characterized by certain patterns of lot arrangement, building height and orientation, and vehicular and pedestrian circulation systems. These criteria determine the relationships between open spaces and built elements, and, therefore, the morphology, or the form, of urban regions, which is based on a set of agreements.

It is important to list and define the important characteristics of these tissue models. This will be done in the following section to prepare for a precise application of the urban tissue model, presented later.

2.253 ELEMENTS

Elements are the separate parts of the urban tissue included in the agreements. There are two kinds of elements: built elements and spatial element. These are differentiated into thematic and non-thematic elements.

Built elements and spatial elements. The relation between built and spatial elements is the most permanent characteristic of a built environment. Functions (use) and properties of elements may change faster. Space is generated as a result of the building process in urban regions: it is necessary to built to create space.

Thematic and non-thematic elements. Elements are defined as thematic if they are of the same kind and if they appear in the whole area which is of interest in the planning process. Thematic elements always have the same relation to other elements. Non-thematic elements are elements that are not commonly found in a tissue, or are located only in some areas of the tissue. In contrast to thematic elements, non-thematic elements can be arranged in different ways.

Because the arrangement of thematic elements is based on a set of rules (agreements), they determine the general characteristics of an urban tissue. Non-thematic elements are not limited by such constraints. They mark the specific and occasional accents of a tissue.

These definitions generate four different kinds of elements which must always be based on the tissue-agreements:

1. thematic built elements (e.g., residential buildings)
2. non-thematic built elements (e.g., schools, churches)
3. thematic spatial elements (e.g., streets)
4. non-thematic spatial elements (e.g., squares)

Spatial elements are created by the positioning of built elements. The characteristics of spatial elements are very important for the perception of the built environment, often more important than the built elements themselves. Changing spatial elements is more difficult than changing built elements (facades, add-ons, etc.) Five different kinds of spatial situations are of interest for the tissue model:

1. linear space defined by width (e.g., streets, alleys, paths)
2. concentric space defined by width and depth
 Because of the different relations of concentric to linear spaces, it is necessary to differentiate the following concentric spaces:
 - 2a. courtyard a space which does not intersect a linear space (e.g., closed courtyard)
 - 2b. front space intersects with a linear space on one side only; local extension of the width of a linear space (e.g., playground, public green, parking lot)
 - 2c. square intersects and connects two or more linear spaces (e.g., market square, city hall plaza)

2.254 FUNCTIONS

Functions of elements are defined as activities which may occur in the elements. It is possible for the same element to 63

have different functions. Function and element relate; for instance, the determination of dimensions and positions of built elements depends on their functional purposes. The following may occur in the element-function relationship:

1. A change in the relation between element and function over time. (After the elements are located, their functions may vary. Examples of such changes: factories changed into loft space, churches changed into concert halls, residential buildings changed into commercial space, town squares changed into parking lots.)
2. An element may be used for different functions. (e.g., a baseball stadium is used for a concert, a street is used as a space for a demonstration or a parade)
3. A function may occur in different kinds of elements. (e.g., parking in spatial elements of all shapes and dimensions, flea markets in both built and spatial elements, shops in residential buildings or garages)

Position and dimension of functions. Differentiating functions and elements makes it possible to investigate the relation between them. This relation is very much dependent on the following two criteria: dimension and position of elements in the environmental context. These two criteria must be differentiated and the following questions asked:

1. Does the position suit the function?
2. Are the dimensions of the elements sufficient for their function?

Because decisions about position determine mutual relations between elements and, therefore, between functions, decisions about position have priority over decisions about dimension. Relations between elements determine the character of an environment and its possibilities of use. The dimensions of an element determine, then, on what scale a function may occur.

Different kinds of functions. Examining a tissue for its functional possibilities, two questions may be asked:

1. For which function or functions is this tissue appropriate?
2. What changes of function will be possible in the future?

It is possible to list different kinds of functions which are relevant to certain tissues. For example, the function of built elements in a residential area is residential use. Some functions related to spatial elements are: private open space, pedestrian and vehicular circulation, public green, playgrounds, and parking.

If a tissue should provide for a variety of future changes or combinations of functions, it is important to know what functions are possible at the beginning of the planning process. If, in the beginning, functions are fixed, this will have a major influence on the whole structure of the tissue.

2.255 NOTATION OF AGREEMENTS

Notation of thematic elements (position and dimension). Thematic elements are notated with zones and margins because all these

elements follow specific patterns which cause a certain continuity. The tissue model differentiates among B-zones, O-zones, and ob-margins (Fig. 1 DOC). A B-zone always contains built elements. An O-zone always contains spatial elements. An ob-margin is an area which contains both built and spatial elements.

The following fourteen rules regulate the notation of thematic elements:

1. A thematic built element is always located in a B-zone and ends in an ob-margin (Fig. 2 DOC)
2. A thematic space is always located in an O-zone and ends in an ob-margin. (Fig. 2 DOC)
3. Ob-margins determine the maximum dimensions of thematic built and spatial elements. (Fig. 2 DOC)
4. The dimension of a B-zone denotes the minimum dimensions of thematic built elements. (Fig. 2 DOC)
5. The dimension of an O-zone denotes the minimum dimensions of thematic spatial elements. (Fig. 2 DOC)
6. Thematic built and spatial elements always meet within an ob-margin. (Fig 2 DOC)

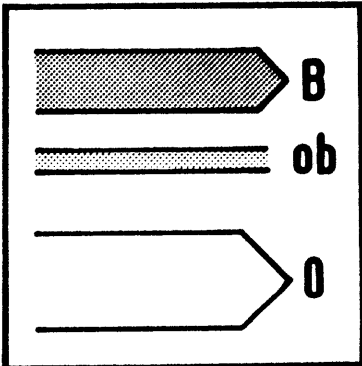

Fig. 1 DOC

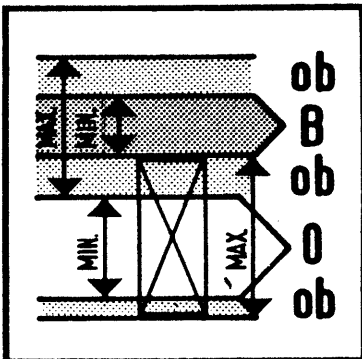

Fig. 2 DOC

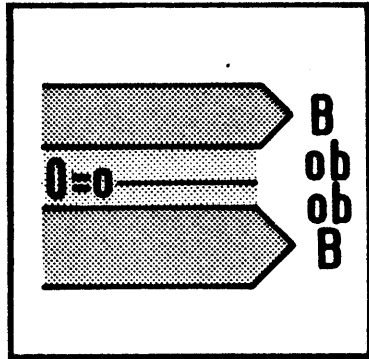

Fig. 3 DOC

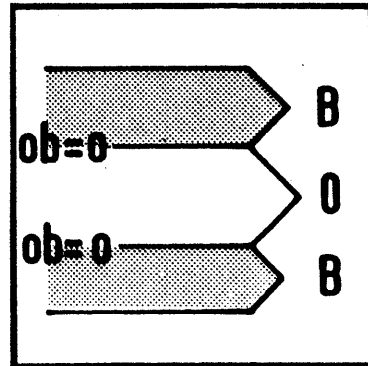

Fig. 4 DOC

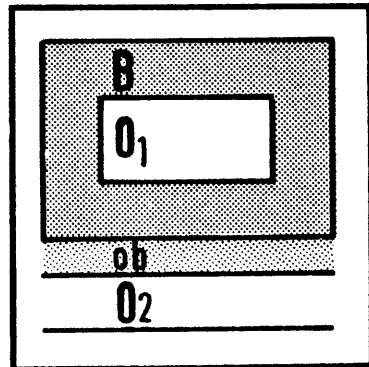

Fig. 5 DOC

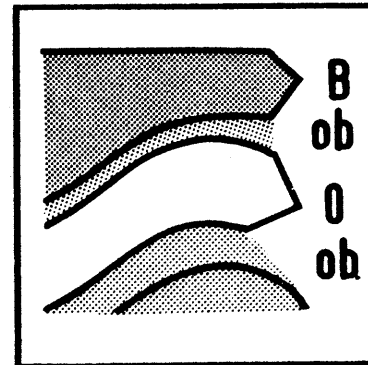

Fig. 6 DOC

7. This system of B-zones, O-zones, and ob-margins can be defined as a determination of zones and margins. It presents the relation between thematic elements and defines their minimum and maximum dimensions.
8. The dimension of an O-zone can be equal to zero. (Fig. 3 DOC) (e.g., The ob-margins have the function of private open space with the possibility of using sixty per cent of this area for add-ons. Because there is no O-zone between the ob-margins (for pedestrian or vehicular circulation) the dimension of the O-zone is zero. No O-zone!
9. The dimension of a margin can also be equal to zero. (Fig. 4 DOC) (e.g., For this to happen, the facades of two opposite building blocks must be located at the edges of the B-zones. The space between them is an O-zone. This means that the dimension of the ob-margin is zero. No ob-margins!
10. Zones and margins do not have to be continuous. (Fig. 5 DOC)
11. Zones and margins do not have to be rectangular. (Fig. 6 DOC) This means that the zoning determination is not dependent on perpendicular

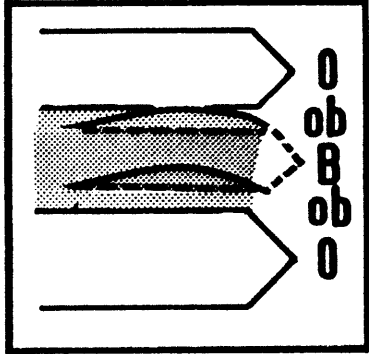

Fig. 7 DOC

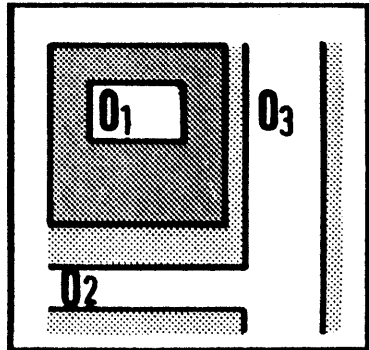

Fig. 8 DOC

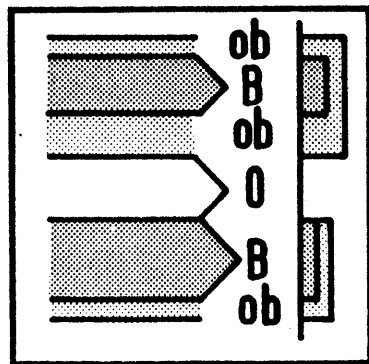

Fig. 9 DOC

lar locations and circulation patterns. It is possible to react with the tissue model to topographical constraints like hills, which will be of interest for the San Francisco models, or to specific existing situations in a tissue which have no perpendicular grid pattern.

12. The position of a zone may vary, although its dimension is fixed and its position specified between two adjacent zones. (Fig. 7 DOC)
13. The determination of zones allows the use of O-zones and B-zones of varying dimensions and positions. Margins may also have different dimensions, but their positions are determined by the location of O-zones and B-zones. (Fig. 8 DOC)
14. The determination of zones may also include agreements about minimum and maximum heights. These additional determinations are notated with section drawings relating to the location of B-zones, O-zones, and ob-margins. This notation of the third dimension enables the quantification of tissue model densities as well as the visualization of relations between building height and the distances between built elements. (Fig. 9 DOC)

Notation of non-thematic elements.

15. Non-thematic elements are not included in notation rules for thematic elements.
16. Nevertheless, it is important to agree on the position and dimension of non-thematic elements. This is done by defining the arrangement of these elements within the zones. Agreements about the position and dimension of non-thematic elements can be made only after zones have been defined, which means that the position and dimension of thematic elements must be fixed.

Every exception to Rules 1, 2, and 4 will result in a non-thematic element. (e.g., Fig. 10 DOC shows three built zones. A section of the B-zone in the center is not built. It is notated as an open zone, defining this area as a non-thematic area. Fig. 11 DOC shows a built section in an O-zone, creating a non-thematic situation for this section of the O-zone. Fig. 9 DOC shows the determination of height for thematic elements. If, in a B-zone, a building has a height greater than the height notated in the section for the zoning determination, that part of the B-zone is non-thematic.)

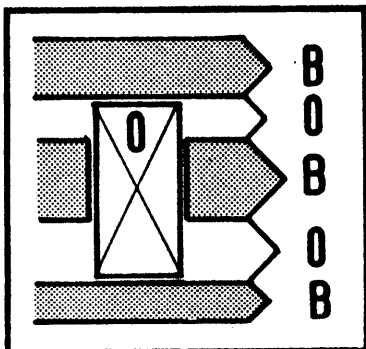

Fig. 10 DOC

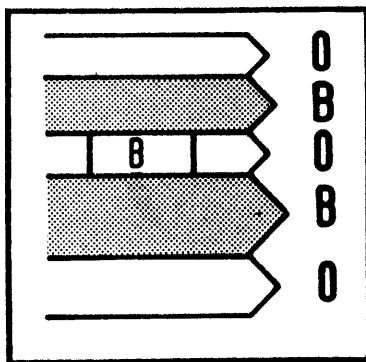

Fig. 11 DOC

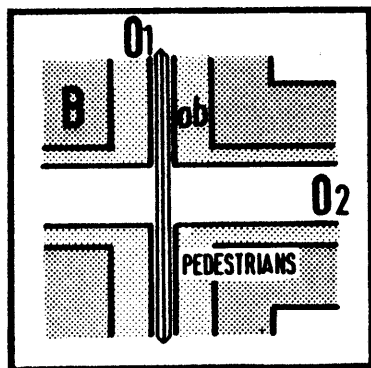

Fig. 12 DOC

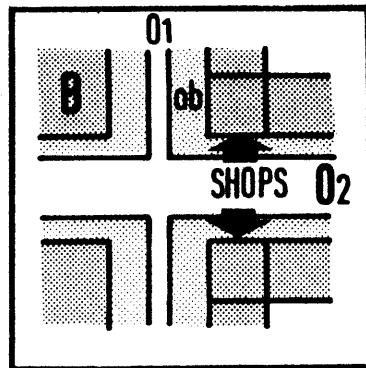

Fig. 13 DOC

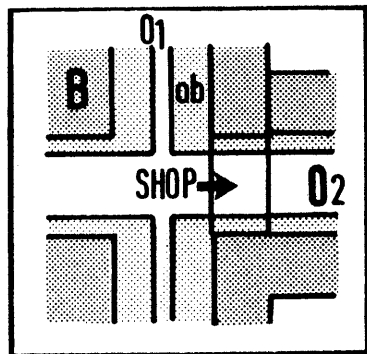

Fig. 14 DOC

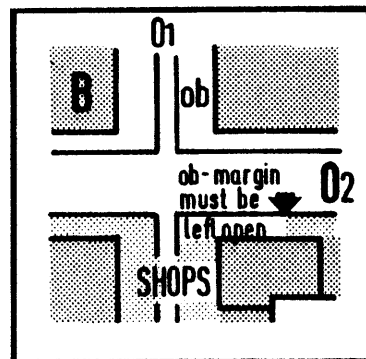

Fig. 15 DOC

Rules 1 to 16 regulate position and dimension of elements. It is also important to define position and dimension of functions, if they have a strong influence on the relation between built and spatial elements.

17. Agreements about functions of thematic elements are denoted by indicating the determining function in the appropriate zone. This means that each element of the zone will have its own specific function. The type of function is indicated by a grid, color, or text. (e.g., A text notation in Fig. 12 DOC indicates that the O_1 -zone has the function of pedestrian circulation only, Fig. 13 DOC indicates shops as the function in two corner locations of opposite B-zones.

18. The function of a non-thematic element is defined by indicating its specific function in the map of agreements, including notations of position and dimension for this non-thematic element. (Fig. 14 DOC)

19. Agreements about function may be combined with detailed determinations of dimensions. These size determinations must be within the dimensions of earlier decisions. (e.g., Fig. 15 DOC)

indicates that shops are planned for one part of a B-zone. The function agreement determines that the ob-margin must remain open at this location.

2.256

DOCUMENTS AND THE TISSUE MODEL

Documents. The rules about notation of agreements in section 2.255 show that agreements must be stated by the determination of zones, thereby defining position and dimension of thematic built and spatial elements. Determinations about non-thematic elements and functions may then be added. Because information is often complex, it is not always possible to combine all kinds of agreements in one plan. Different types of agreements may be indicated on different agreement sheets. Each sheet will include the zone determination and additional agreements, if necessary. A sheet which includes information about zoning determinations and related agreements of position, dimension, and function of elements is called a document of agreements.

Very complex situations will make separate and detailed additional agreements necessary in a separate section for comments.

It is important to distinguish between documents of agreements and comments. While documents denoting zoning determinations are obligatory for all decisions made later in the planning process, comments have less influence on future decisions in the planning process.

Tissue model. Documents which relate to a tissue represent the tissue model. The tissue model includes all agreements about the position, dimension, and function of thematic built and spatial elements as well as of all non-thematic built and spatial elements of a certain area. The tissue model may include various kinds of comments, in addition to the agreements.

Labeling the documents. To code different information in each document it is useful to apply the labeling scheme shown in Fig. 16 DOC. This label codes morphological and functional information as well as comments and criteria for thematic and non-thematic elements and spaces. The letters and figures in this label have the following meanings:

M - Document includes information which is not based on functions and determinations about position and dimension of elements (morphology).

F - Document includes information which is based on functions.

tb - Document includes determinations about thematic built elements.

to - Document includes agreements about non-thematic built elements.

ntb - Document includes information about non-thematic built elements.

nto - Document includes information about non-thematic spatial elements.

The right vertical column (F) which codes different kinds of function information has separate parts, "a" and "b" for each field.

	M	F
tb	1	a5b
to	2	6
ntb	3	7
nto	4	8

Fig. 16 DOC

"a" indicates that the document contains information about the position of functions; "b" indicates that the document contains information about dimensions of functions.

Each field contains a figure which codes a specific kind of information. A document may include information about more than one figure, but it is recommended to prepare documents with only one number, as described below, to reduce the complexity of information in any one document. An exception to this is the document for determination of zones. This document includes information about Figures 1 & 2. No tissue model is possible with Document 1 & 2.

Document 1 provides information about the determination of thematic built elements. This may be an analysis of different B-zones, with additional information about possible support variations and their orientation. It may also indicate possible functions of these elements, such as shops and schools.

Document 2 provides information about the determination of thematic spatial elements, listing minimum and maximum dimensions of width, length, and height for these elements.

Document 3 provides information about position and dimensions of non-thematic built elements, especially their location within the zones.

Document 4 provides information about the determination of non-thematic spatial elements, indicating interruptions in the continuity of built zones.

- Document 5a provides information about additional agreements of zoning determination relating to the position of certain functions of thematic built elements.
- Document 5b provides information about additional agreements of zoning determination relating to the dimensions of certain functions of thematic built elements.
- Document 6a provides information about additional agreements of zoning determination relating to the position of certain functions of thematic spatial elements.
- Document 6b provides information about additional agreements of zoning determination relating to the dimensions of functions of thematic spatial elements.
- Document 7a includes a number of additional agreements about zoning determinations described in Document 3 relating to the position of certain functions of non-thematic built elements. The relation between a non-thematic built element and its function can be the following: a) a certain built zone must include a specific function, and b) a certain function can only exist in a specific built zone.
- Document 7b includes a number of additional agreements about zoning determinations described in Document 3 relating to dimensions of non-thematic built elements.
- Document 8a includes a set of additional agreements about zoning determinations described in Document 4 relating to the

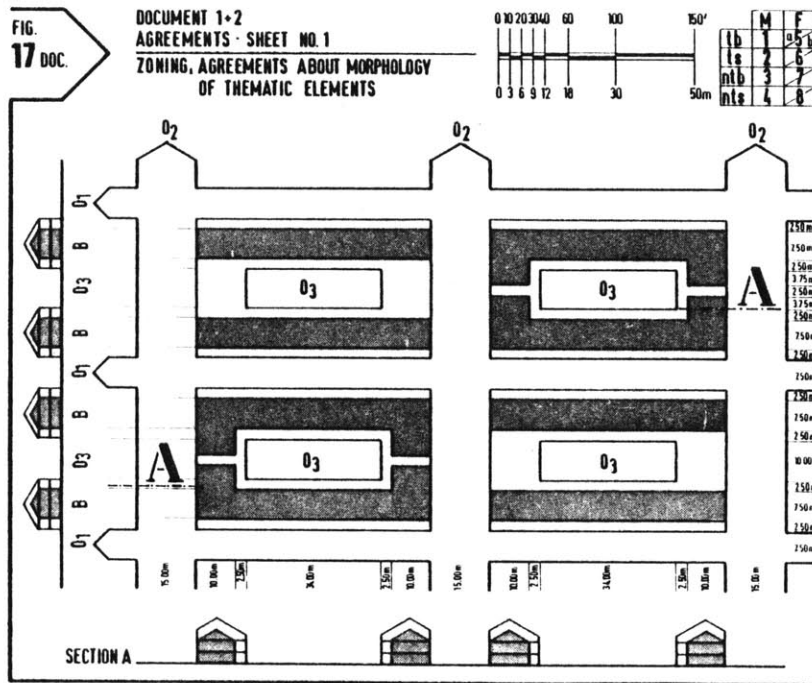

Fig. 17 DOC

position of certain functions of non-thematic spatial elements. The relation between a non-thematic spatial element and a certain function may exist in the following two ways: a) a certain spatial element must serve a specific function, and b) a certain function can only occur in a specific spatial element.

An example of the notation of a tissue model is given in Figure 17 DOC. It carries the label "Figures 1 & 2" which means that it provides information about position and dimensions of B-zones, O-zones, and ob-margins (determinations of zones). Two sections are made in two directions and indicate the minimum and maximum height of built elements in B-zones and ob-margins.

Document 1 & 2 presents the morphology of the tissue and its basic agreements about thematic built and spatial elements. This document is absolutely necessary for each tissue model. Based on its determinations, the improvement of the tissue model by adding or changing certain conditions not included in Document 1 & 2 becomes possible.

The tissue model can be transformed and deformed. Transformation of a tissue model is defined as a

change of zone dimensions without changing the correlations of zones (e.g., Two models are based on the same location of zones $[B_1, B_2, O_1, O_2]$. These zones have the same correlation in both models. They are differentiated only by their dimensions and the size of their margins. In this case, one zoning arrangement is a transformation of the other.) Deformation of a tissue model is defined as a change caused by local interference by topography or the existing built situation.

A tissue model does not correspond to a specific situation. It includes only agreements about location, dimension, and functions of elements. If such a tissue model is adapted to a specific situation, it is possible that for some parts of the area local interference may cause a certain divergence from the basic determinations. It may become necessary to change the dimensions of zones and margins or even their location. This will create a non-thematic area; there are no agreements about this location in the tissue model. These local deformations of the tissue model, caused by non-thematic elements, can give interesting characteristics to the tissue model.

Variations of the tissue model. A tissue model is not a specific site plan. A plan is a scale reproduction of a specific existing or planned situation. The tissue model only shows agreements about location, dimension, and function of elements which will later appear in a plan. Within the limits created by the determinations of the tissue model, it is possible to have a

number of variations. One of the most important advantages of an application of the tissue model is the determination of agreements which will be obligatory for all plan variations. Based on a tissue model, it is possible to methodically develop a number of variations for a given situation. These variations may be quantified and evaluated, leading to the optimization of a final variation. Different variations of a tissue model can be tested. These tests may show that certain agreements in the tissue model are inconvenient and must be changed.

2.257

APPLICATION OF THE TISSUE MODEL METHOD

The tissue model method can be used in the planning process as a tool to generate norms for the location, function, and dimension of certain elements, as a communication tool during the participatory planning process, as a tool to quantify required determinations, costs, and needed spaces for housing projects, and as a tool for renewal programs in existing urban situations.

This study will apply the concepts of this method to an analysis of the area around Alamo Square. Notation systems for tissue types, function models and tissue models are based on SAR 73.

The structure of the Victorian block tissue differs in some aspects from the SAR 73 tissue model, which is based on a continuous support structure. SAR 73 regulates the zoning, in both depth and height, of a support. If an opening interrupts this support, it is a non-thematic element and notated as such.

The analysis of the built elements in Alamo Square and their correlations indicates certain patterns of 0-zones and ob-margins perpendicular to the street, generated by side clearances, recesses and specific entrance arrangements of the Victorian townhouse. Regarding these criteria, an additional zoning system, perpendicular to the street, will be introduced.

Figure 73 indicates the three zoning systems for a single unit. Vertical zoning and zoning parallel to the street regulate the height and position of the support. Zoning perpendicular to the street will consider interruptions of the continuous street facade. For a single dwelling, the B-zone of this zoning system indicates location and dimension of the main house, the ob-margin defines location of elements which cover only a part of the adjacent space (recesses, side add-ons, fire escapes, corner towers, and side bays). Assembling a number of townhouse types which have such elements creates a pattern of ob-margins and 0-zones for the zoning on the support level.

The zoning system perpendicular to the street will be used to quantify and evaluate existing patterns of the Victorian streetscape, as well as to

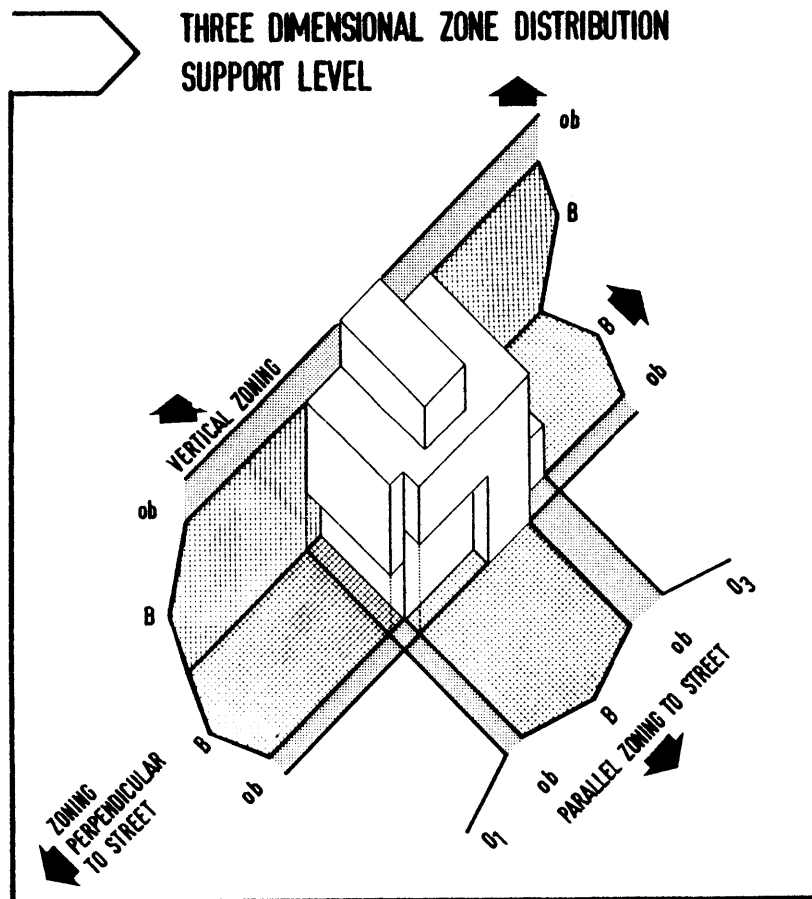

Fig. 73

develop rules for the morphological adaptation of infill projects and new developments to the existing block fabric.

The tissue model will differentiate a zoning system on the support level and on the tissue level. A single dwelling unit of the existing fabric may be zoned into a B-zone, which contains the main house, and ob-margins in front and in back, where bays, porches and add-ons are located. Because of different set-back dimensions, location of these zones may vary from one unit to another.

Figure 74 shows the different zoning scales and their relation. The zoning on the support level is identical to the zoning on the tissue level, if support sectors have the same depth and location for the B-zone and ob-margins. (Fig. 74, top) If support B-zones with identical depths have different set-backs, the support has a "variable position." This is a very common situation in the Victorian pattern which generates a less deep B-zone and deeper ob-margins in the tissue level zoning. (Fig. 74, center) An ensemble of dwellings with different set-backs and depths also generates different dimensions for zones on the support and tissue levels. (Fig. 74, bottom)

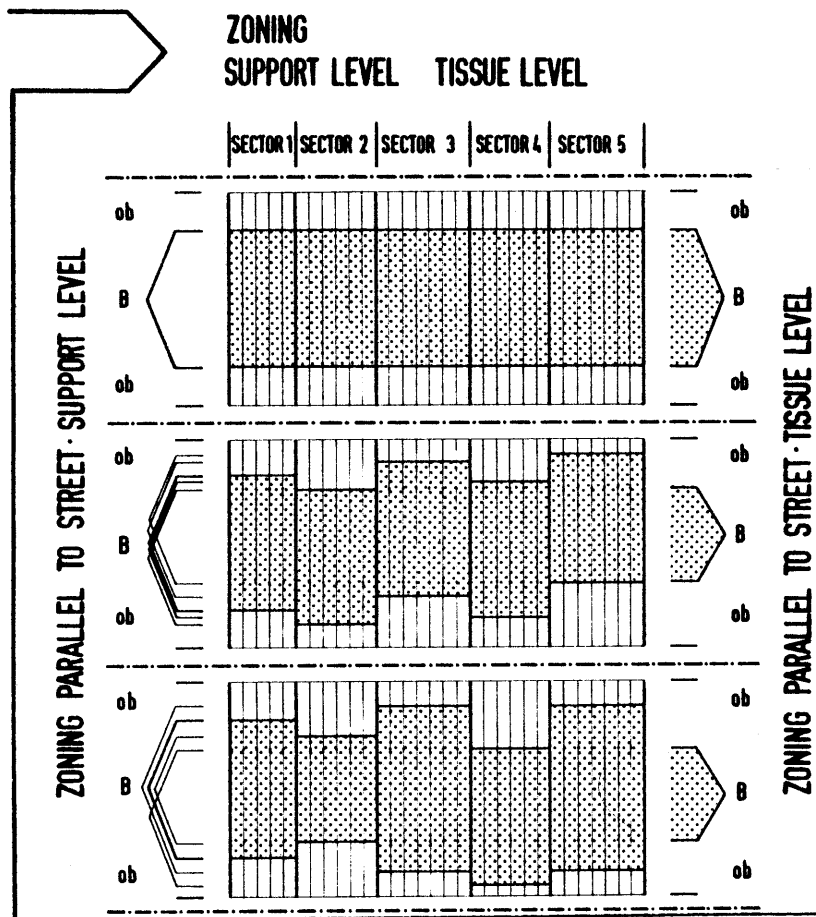

Fig. 74



Fig. 75 Alamo Square

2.3 ANALYSIS OF BLOCK 1155

A general analysis of the existing block tissue around Alamo Square was presented in section 2.2; a more specific analysis for a typical block will be presented. In the following section, an application of the SAR 73 tissue analysis method will be demonstrated with the intention of defining the characteristics of the physical environment and notating the general zoning distribution of the block tissue as a basis for development of a tissue model.

2.31 BLOCK FABRIC IN RELATION TO ADJACENT REGIONS

Block 1155 is located in the Western Addition, one block north of Alamo Square. The block layout has the generic dimensions of 275' x 437'6" (82.5 m x 131.25 m). Some adjacent areas, such as the area along Terra Vista Drive, northwest of Alamo Square, and certain blocks west of Gough Street and southeast of Alamo Square, have different forms and dimensions of blocks which result in different circulation and tissue patterns. (Fig. 75)

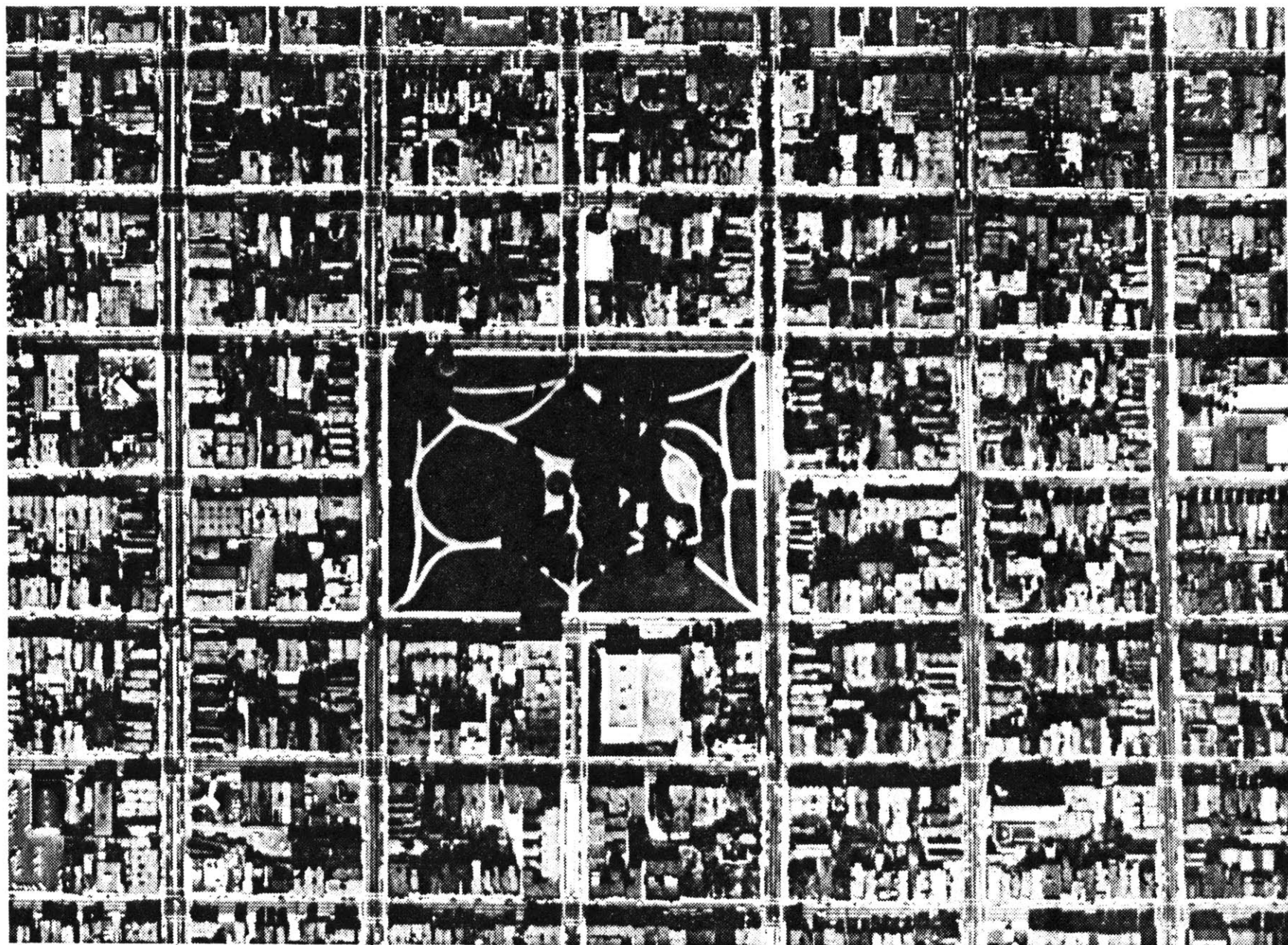

Fig. 76

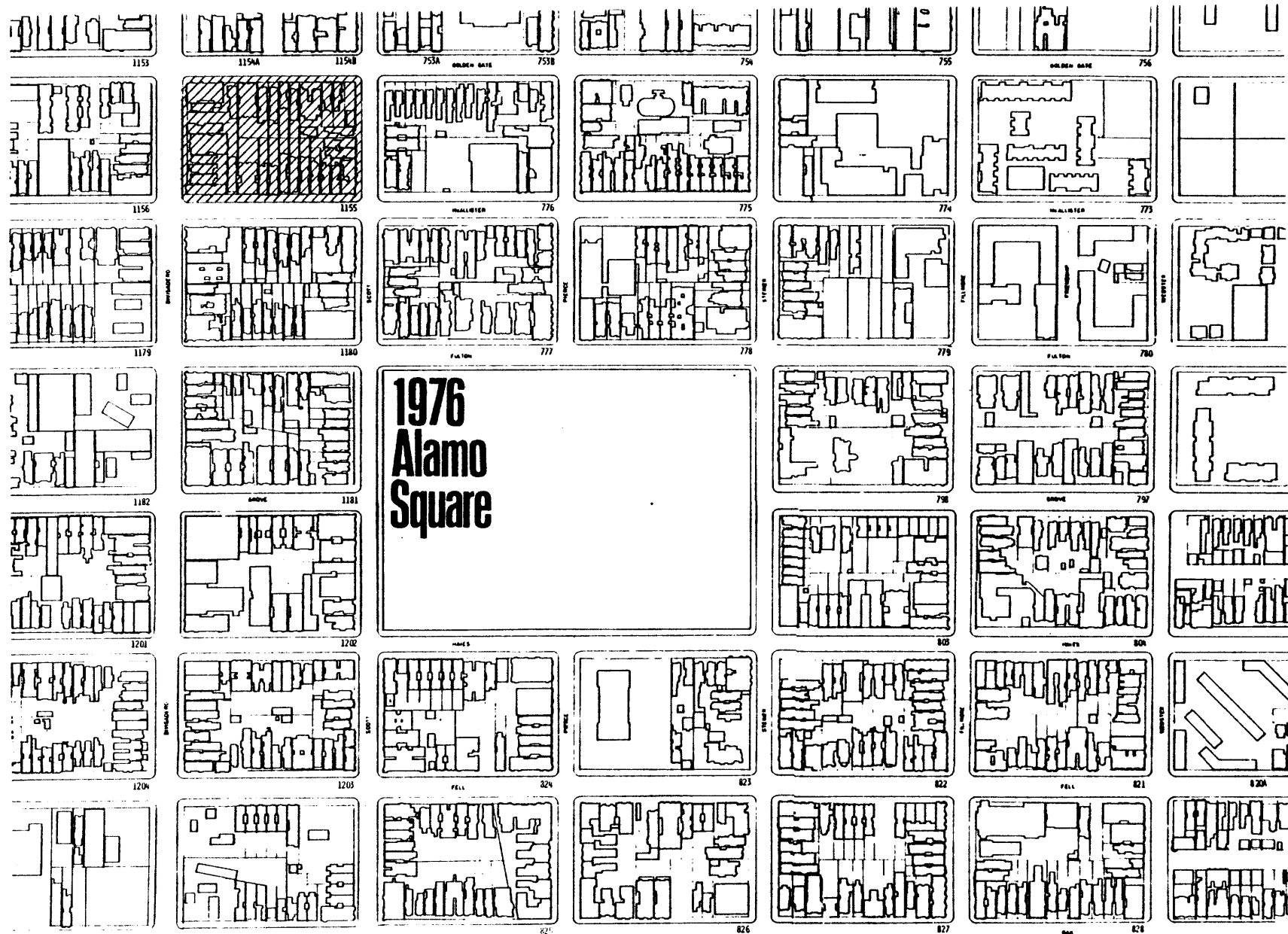

Fig. 77

2.32

BLOCK FABRIC IN RELATION TO ADJACENT BLOCKS

Generic block dimensions characterize the urban tissue of the Alamo Square area. Most blocks are full blocks, without an alley. North of Block 1155 there is a half-block arrangement with a short alley. Neighboring blocks have different lot subdivision patterns and distribution of building types and sizes, and similar morphology and streetscapes.

An aerial photograph (Fig. 76) provides an overview of the existing morphological situation. Individual buildings and lot subdivision patterns are shown in Figure 77.

2.33

THE MORPHOLOGY OF THE BLOCK

Certain building correlation patterns occur in the fabric of almost every block. Homogeneous streetscapes are rare; the influence of the individual on single buildings has created variety in the streetscape.

Block 1155 is subdivided into lots of typical sizes, each between 25' (7.5 m) and 50' (15.2 m) wide. Each lot has been developed separately.

An aerial photograph (Fig. 78) presents the correlation of building masses. Flat roofs indicate large apartment buildings. Light wells are located in the center of these buildings and along the sides of the houses.

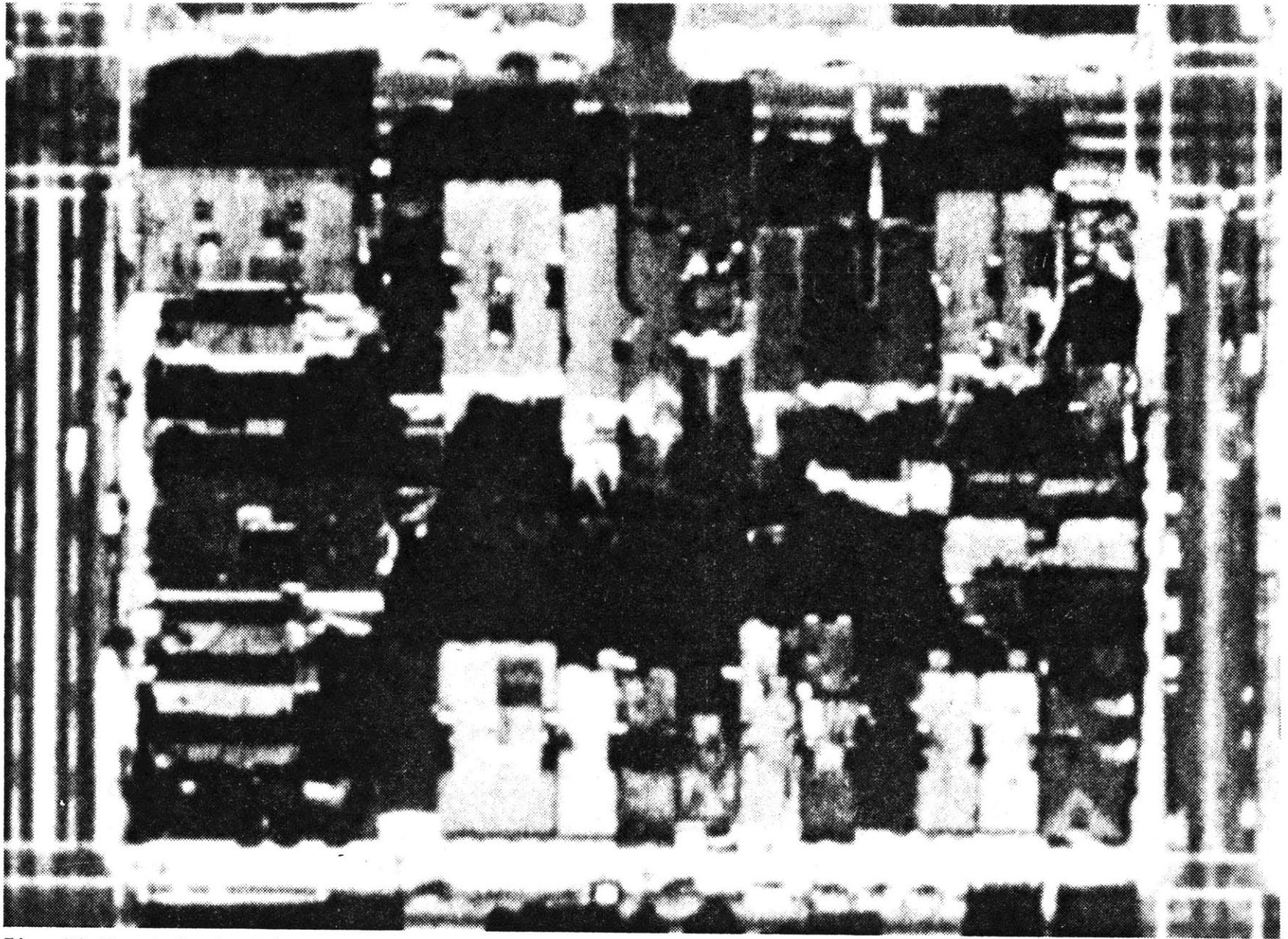

Fig. 78 Morphological Roof Texture

**BLOCK 1155 - EXISTING SITUATION 1978
LOCATION AND SHAPES OF BUILT ELEMENTS
IN RELATION TO OPEN SPACES**

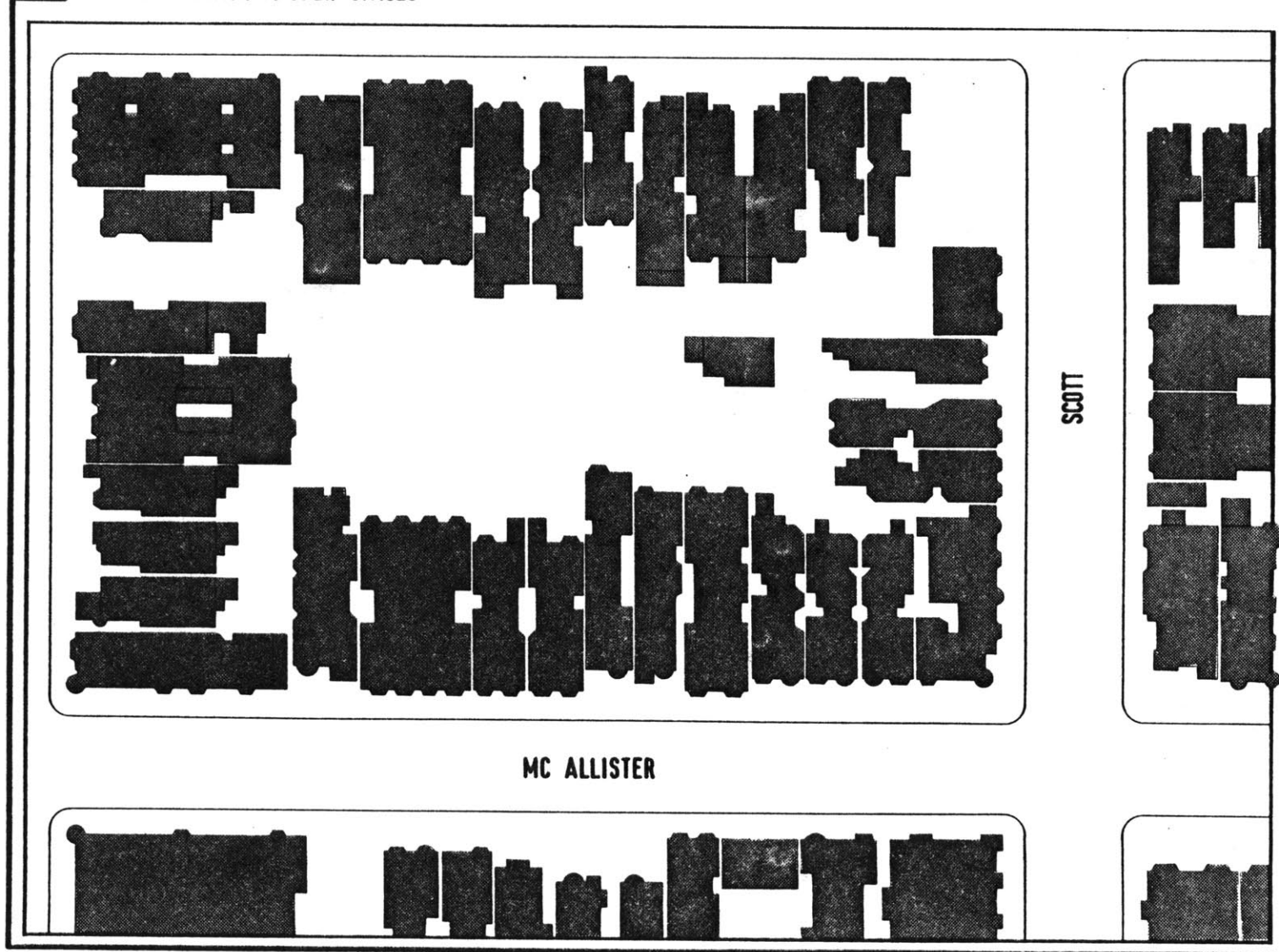

Fig. 79

2.331
RELATION OF OPEN AND BUILT ELEMENTS

The location and shapes of buildings are presented in Figure 79. Buildings are all located along major streets. This block is dominated by the narrow, deep townhouse type. Four larger types of apartment houses are located on three sides of the block.

The block contains a total of thirty-one buildings with an average coverage of 1771 square feet. Building coverage, the relation of built to open space, for the whole block is 51.5 per cent.

2.332
STREETSCAPES — PUBLIC AND SEMI-PUBLIC AREAS

The non-continuous facade elevation has a strong impact on the morphological character of the streetscape. Figure 80 shows visible public space, space which although it may have a semi-public circulation function can be seen from the street, in relation to the edges of the private space generated by buildings or visual barriers such as fences and bushes. Because of different set-backs and recesses, bay window arrangements, and open lot situations, the boundary is not straight and continuous. Comparing two opposite street elevations, the

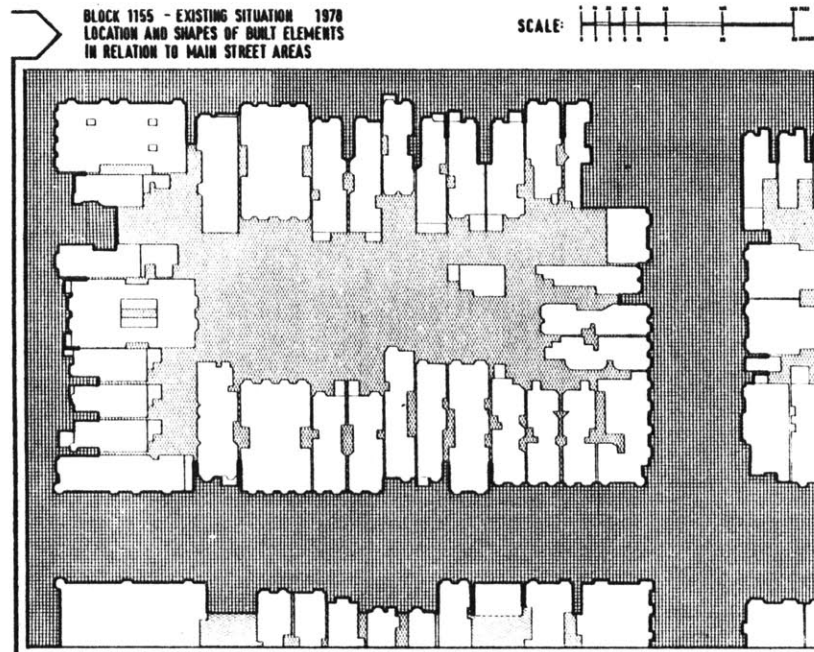

Fig. 80 Block 1155 (1976)

variation in private and public space shapes becomes even more complex.

Along McAllister Street, larger buildings emphasize corners. In intermediate locations, houses tend to be set back. Major spatial variations are provided by set-back locations and adjacent locations of detached buildings and recesses. Numerous bays create less deep spatial variations.

Figure 81 differentiates streetscape spaces into a public zone, the streets and sidewalks, and a semi-public zone, the area between the sidewalks and buildings. Because of front lot line locations and varying set-back depths and recess sizes, the semi-public zone is also not continuous.

The streetscape analysis in Figures 80 and 81 examined only the two dimensional morphological situation of the existing block fabric. The axonometric drawing in Figure 82 indicates that the correlations of built elements increase in complexity when the third dimension is taken into consideration. Staircases and proches cover only a part of the facade elevation. Roofs have different shapes, buildings different heights. The house elevation facing the inside of the block shows the attachment of add-ons to the complete main floor

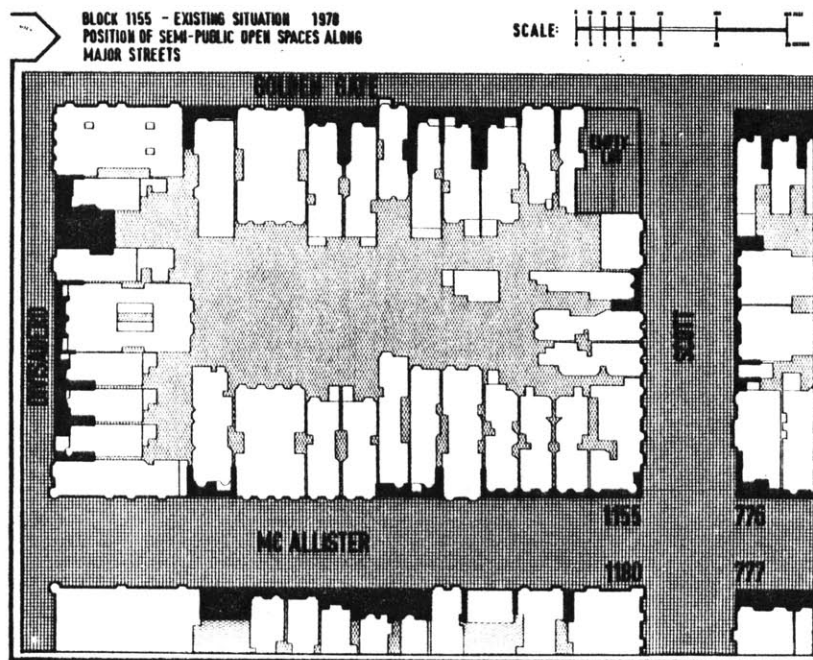

Fig. 81 Block 1155 (1976)

**BLOCK 1155 - EXISTING SITUATION 1970
AXONOMETRIC OF BUILT ELEMENTS**

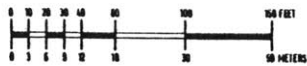
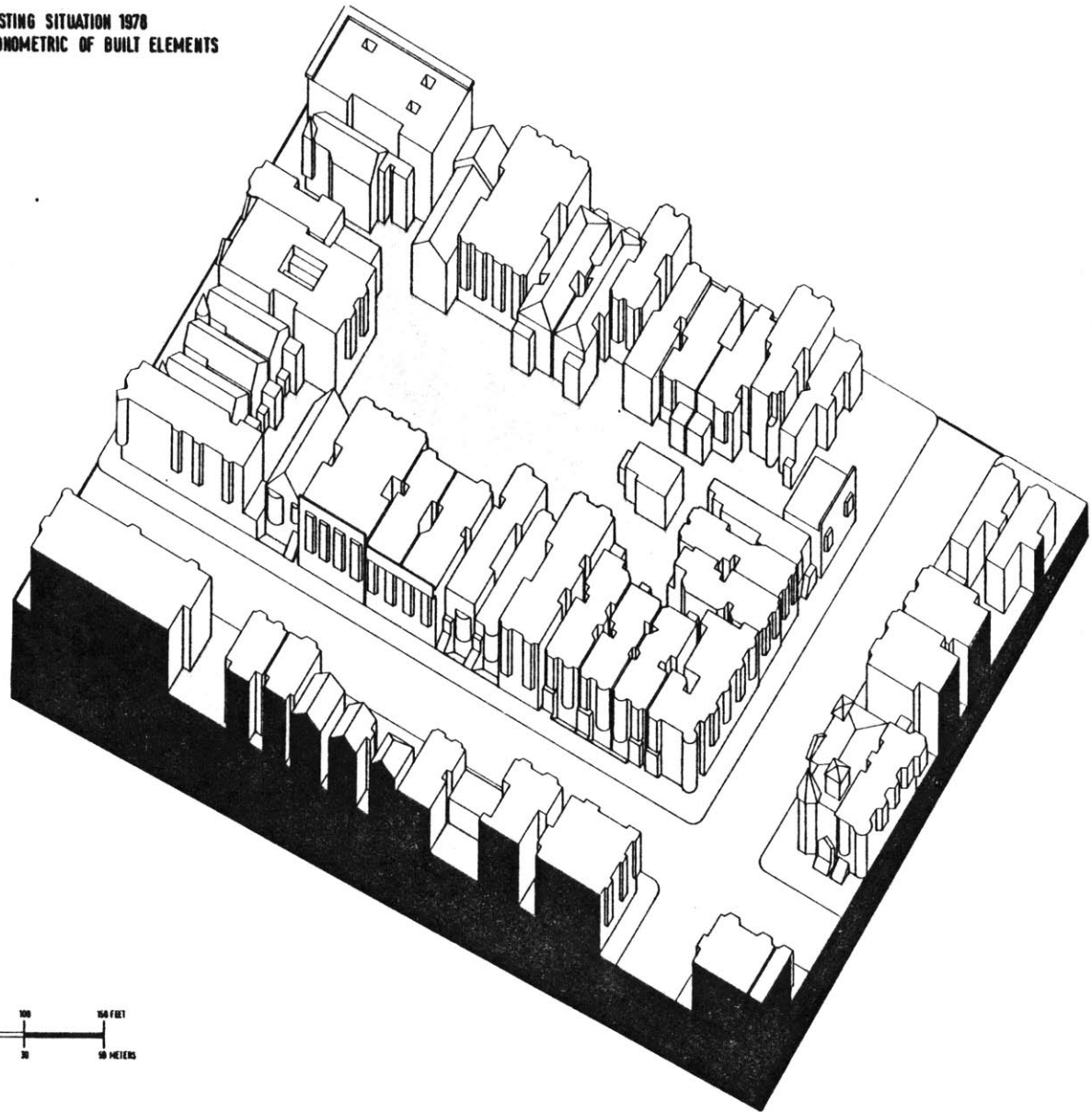

Fig. 82

STREET ELEVATION MC. ALLISTER BLOCK 1155

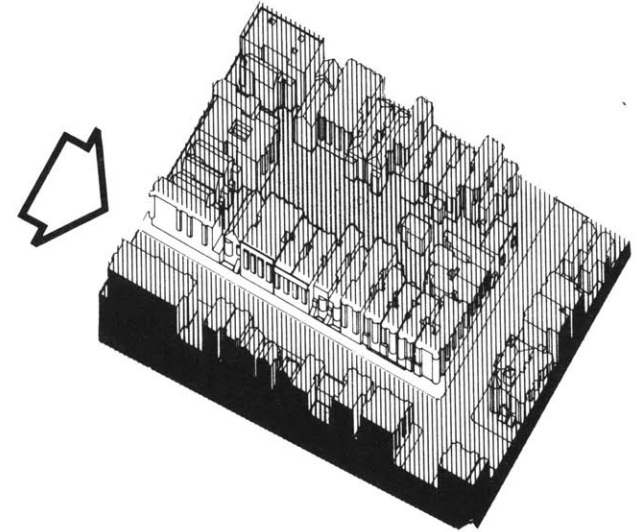

Fig. 83

area or only the first or second floor. Bay windows are not continuous vertical elements which extend from the base to the cornice of a building; they are not found in the back as often as in the front. With the exception of one building, the inside of this block is free of built elements.

This analysis emphasizes the morphology of streetscape-oriented elements. The street elevation of McAllister Street (Fig. 83) is a photomontage of photographs taken in 1977. The montage visualizes characteristics of the streetscape patterns, as well as specific individual elements and their correlation.

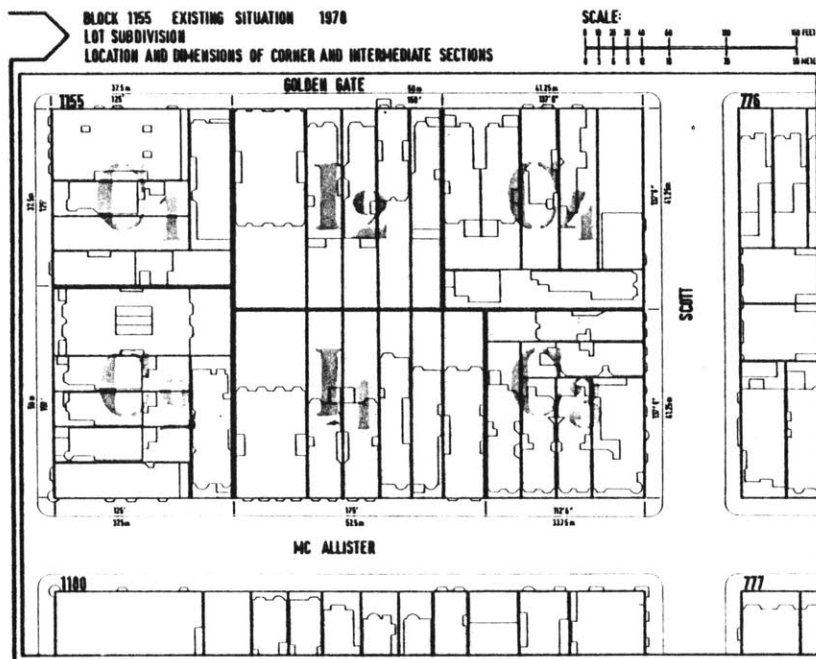

Fig. 84 Block 1155 Lot Location Areas

2.34 CRITERIA WHICH INFLUENCE THE MORPHOLOGICAL PATTERNS OF THE STREETScape

As stated in section 2.122, blocks were divided into six equal-sized square parcels of 137'6" (41.25 m). These generic parcels were later subdivided. Analysis of corner and intermediate location areas indicates the tendency to extend the intermediate lot location area to the corners.

Figure 84 denotes the location of areas of Block 1155. Corner areas C_1 , C_2 , and C_3 have not the depth of the generic parcel size. Intermediate

areas I_1 and I_2 have an increased width of 175' (52.5 m) and 150' (45 m), respectively.

Dimensions of subdivided lots are presented in Figure 85. This block contains thirty-three lots of which twenty-seven may be defined as thematic, having a width of 30' or less and a depth of 87'6" or more. Six lots contain apartment buildings wider than 30' (9 m).

Variations in lot sizes occur in the corner location areas. C_1 and C_2 have similar lot subdivision patterns. C_3 and C_4 , corner areas on the other end of the block, differ from each other. Location area C_3 , where the generic parcel was subdivided into seven lots, is an interesting example of maximizing the number of lots.

The cross and main streets have different widths. Divisadero Street is 13'9" (4.125 m) wider than the generic street dimension of 68'9" (20.625 m).

The width of a lot, which regulates the maximum width of a lot-related building, is only one criterion which influences the morphology of a streetscape. Other criteria, which regulate the morphology of vertical elements in the street elevation, are expressed by dimensions relating to a built object.

The width of a single building and its location on a lot is a second module which must be considered. This module influences the distribution of large volumes such as the main house or box.

Another module is provided by the location and width of front add-ons, bay windows, balconies, corner towers, porches and stairs.

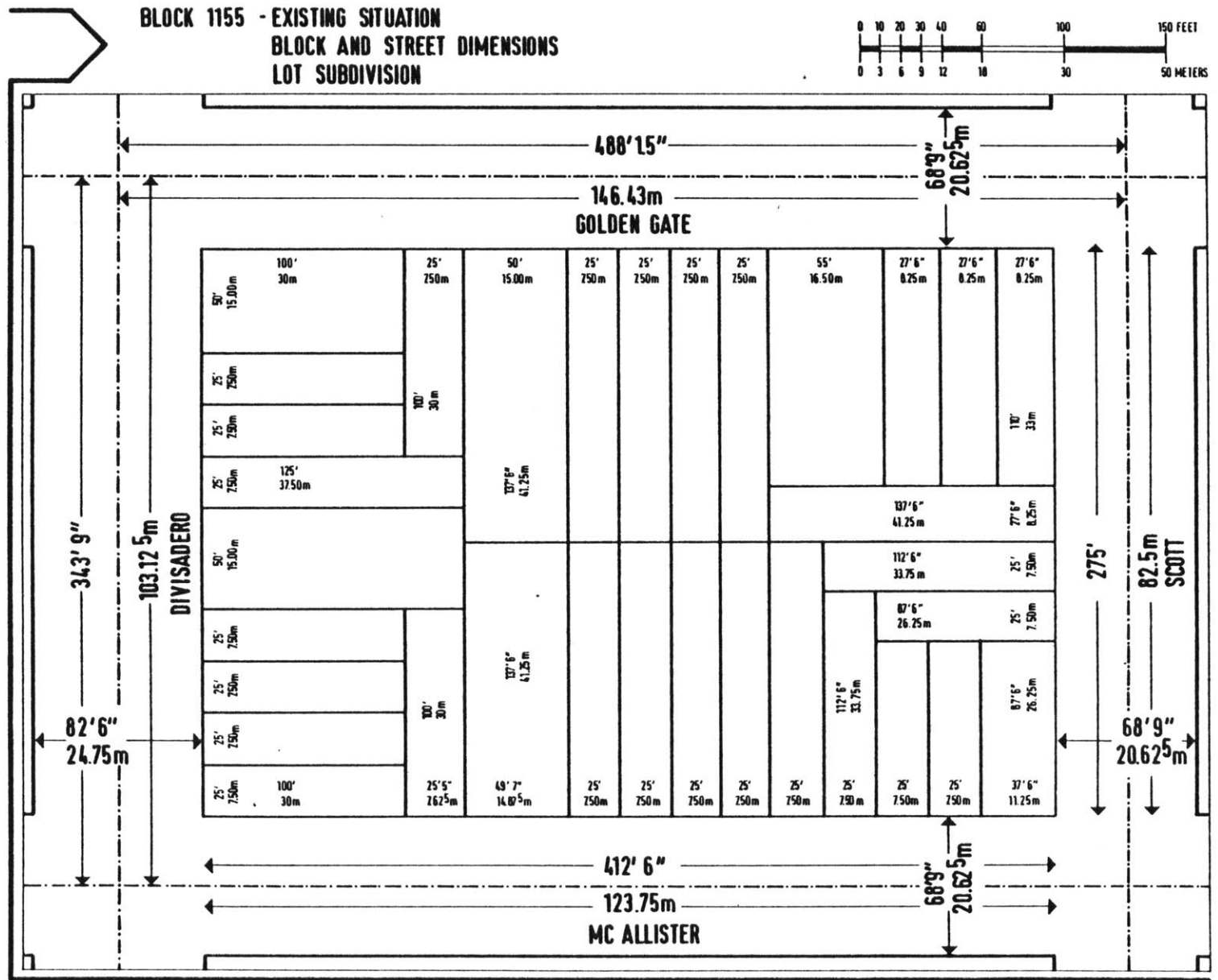

Fig. 85

In Figures 86 and 87, two main street elevations are analyzed using these three modules to define vertical breaks in the continuity of the street elevations. Figure 85 represents the street elevation on McAllister Street, which has twelve separate lots. Figure 87 shows the Golden Gate street elevation which has eleven separate lots.

The section "Relation of Modules" in these two figures, indicates a significant difference between the rhythms of modules A and B. Because of their small dimensions and repetitive character, bay window modules of different buildings appear to be similar. Comparing both diagrams, the patterns which regulate the verticals of the built environment, as well as the differences generated by the individual architecture of each buildings, become obvious.

2.35

ZONING ANALYSIS OF BLOCK 1155

The distribution of buildings along the streets is based on certain patterns which were explained in section 2.133. On the tissue level, ob-margins are generated by set-backs and the arrangement of buildings with different depths.

The following section analyzes the specific characteristics of existing built elements in relation to their location in ob-margins and the B-zone, parallel to the street.

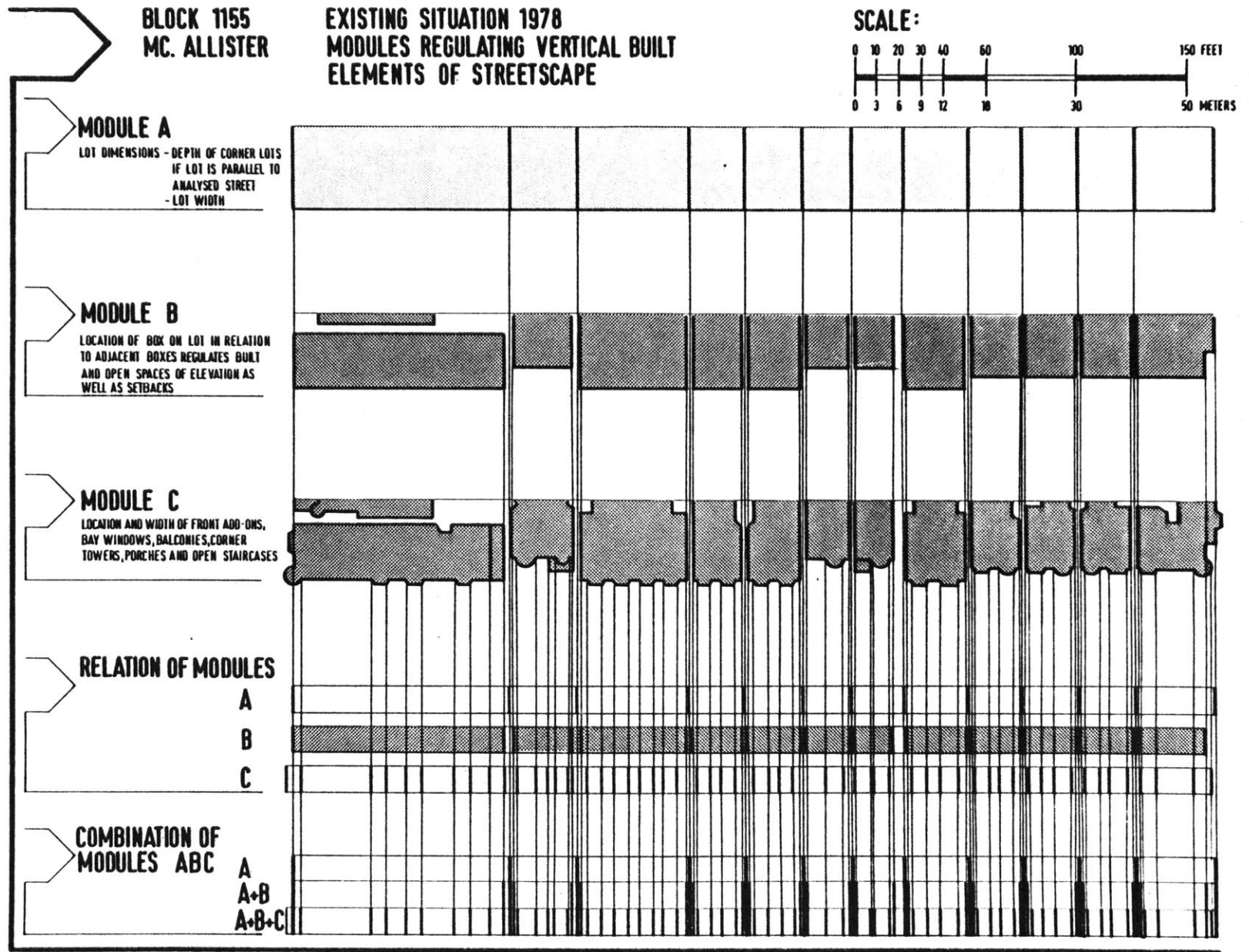

Fig. 86

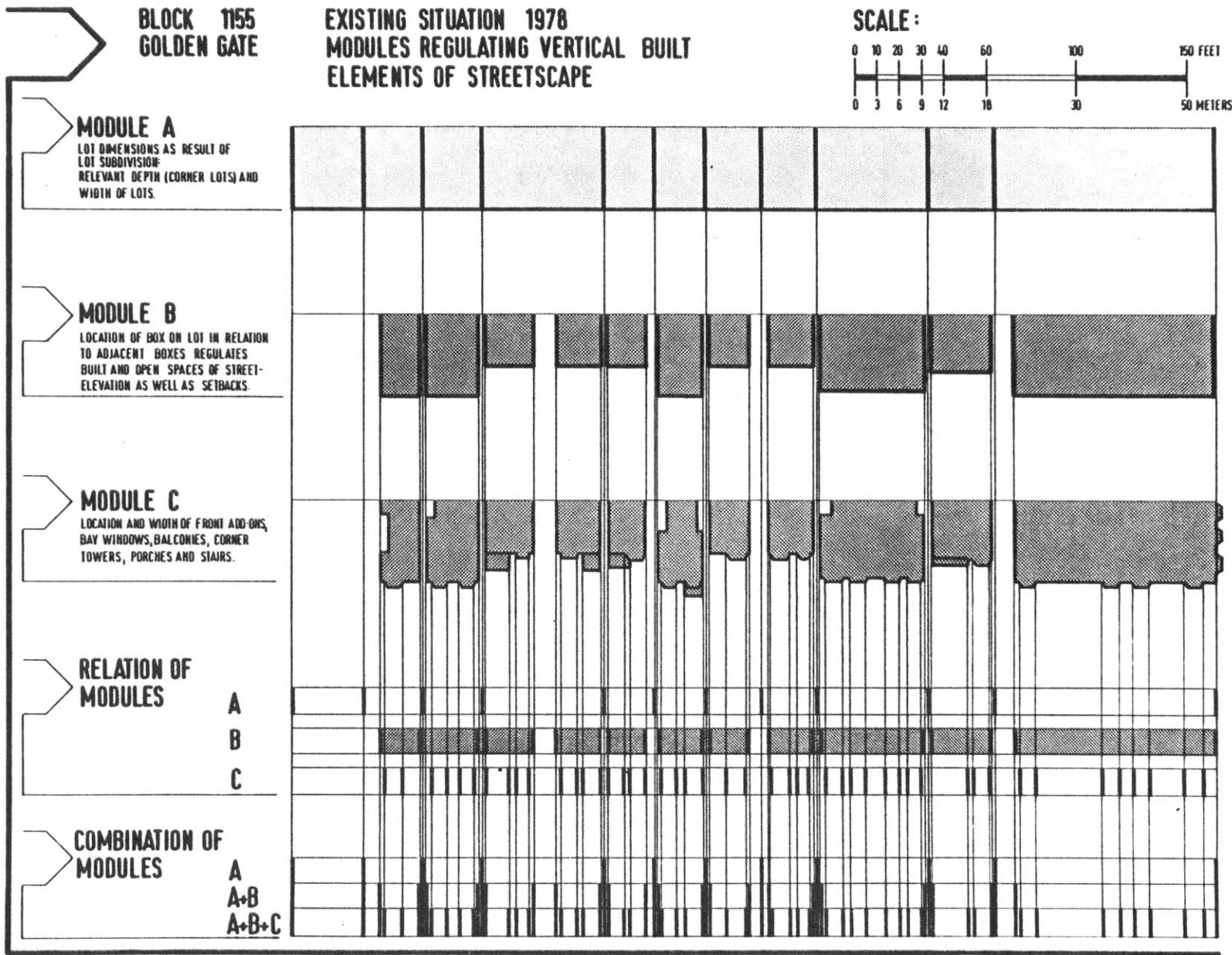

Fig. 87

2.351

DIMENSION AND LOCATION OF BUILDINGS AS THE BASIS FOR A ZONING SYSTEM

Built elements are located in different positions along the street and have different depths. Figure 88 shows the ob-margins of a space, along the street and inside the block, which are not always covered by buildings. Depending on the set-back depth, this space can be open or built in the front. Deep buildings or buildings with a deep set-back from the sidewalk extend into the ob-margin in the inner block. Between these two ob-margins is the B-zone, a zone in which built elements are located.

2.352

CHARACTERISTICS OF THE B-ZONE

SAR 73 is based on a continuous support zoning. (For a discussion of SAR 73, see section 2.25) Buildings of the San Francisco block fabric have recesses, side clearances, and light wells. These elements reach into the B-zone, a fact which is taken into consideration by using an additional zoning system perpendicular to the street (see section 2.257).

The depth of the B-zone in the existing block fabric is generated by deep house types. These buildings have an average depth of sixty feet. Add-ons and additions may extend this depth. Recesses and light wells supply enough light; the "railroad plan" of arranging rooms along a hallway provides sufficient circulation (see section 2.1342).

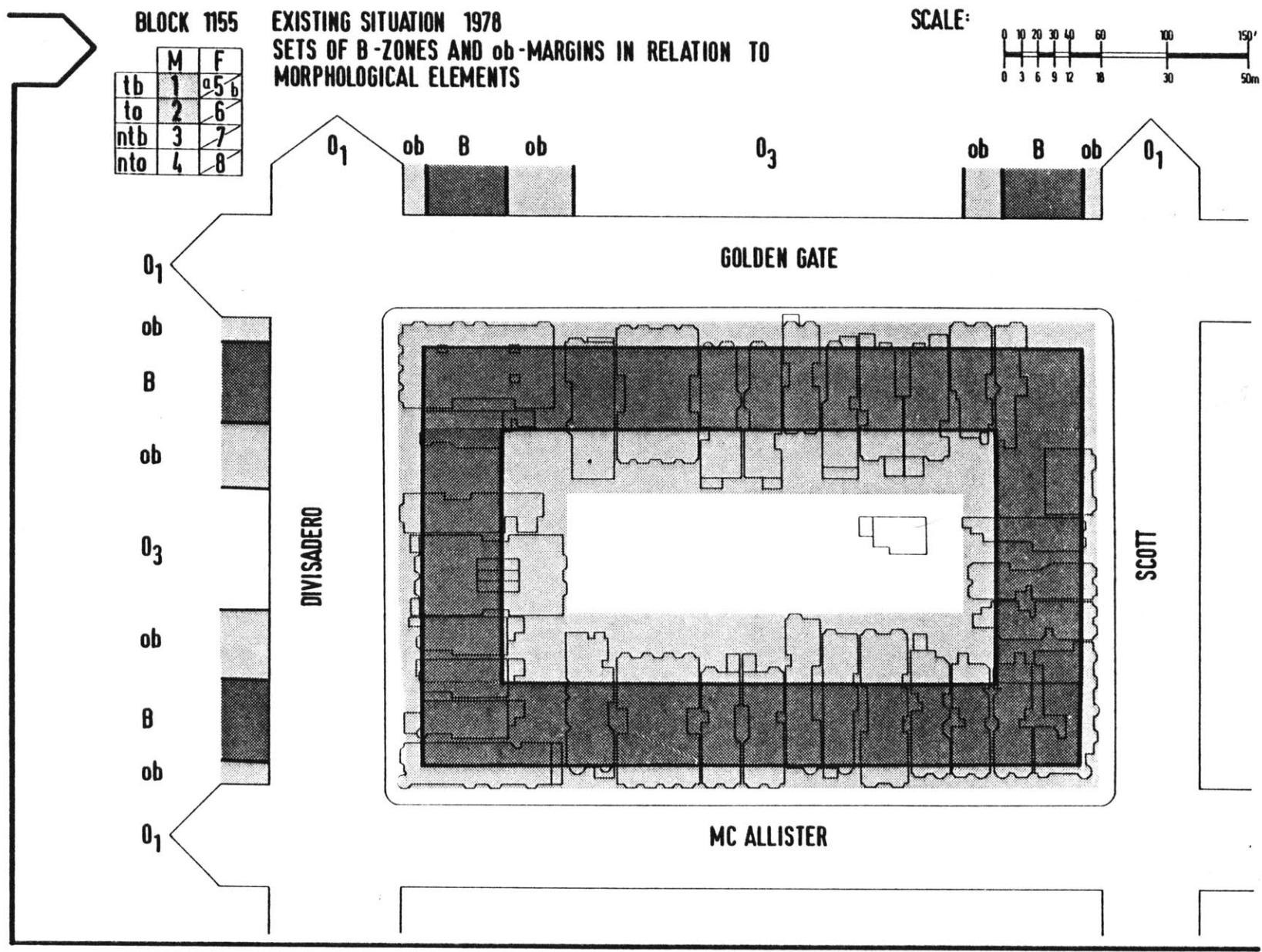

Fig. 88

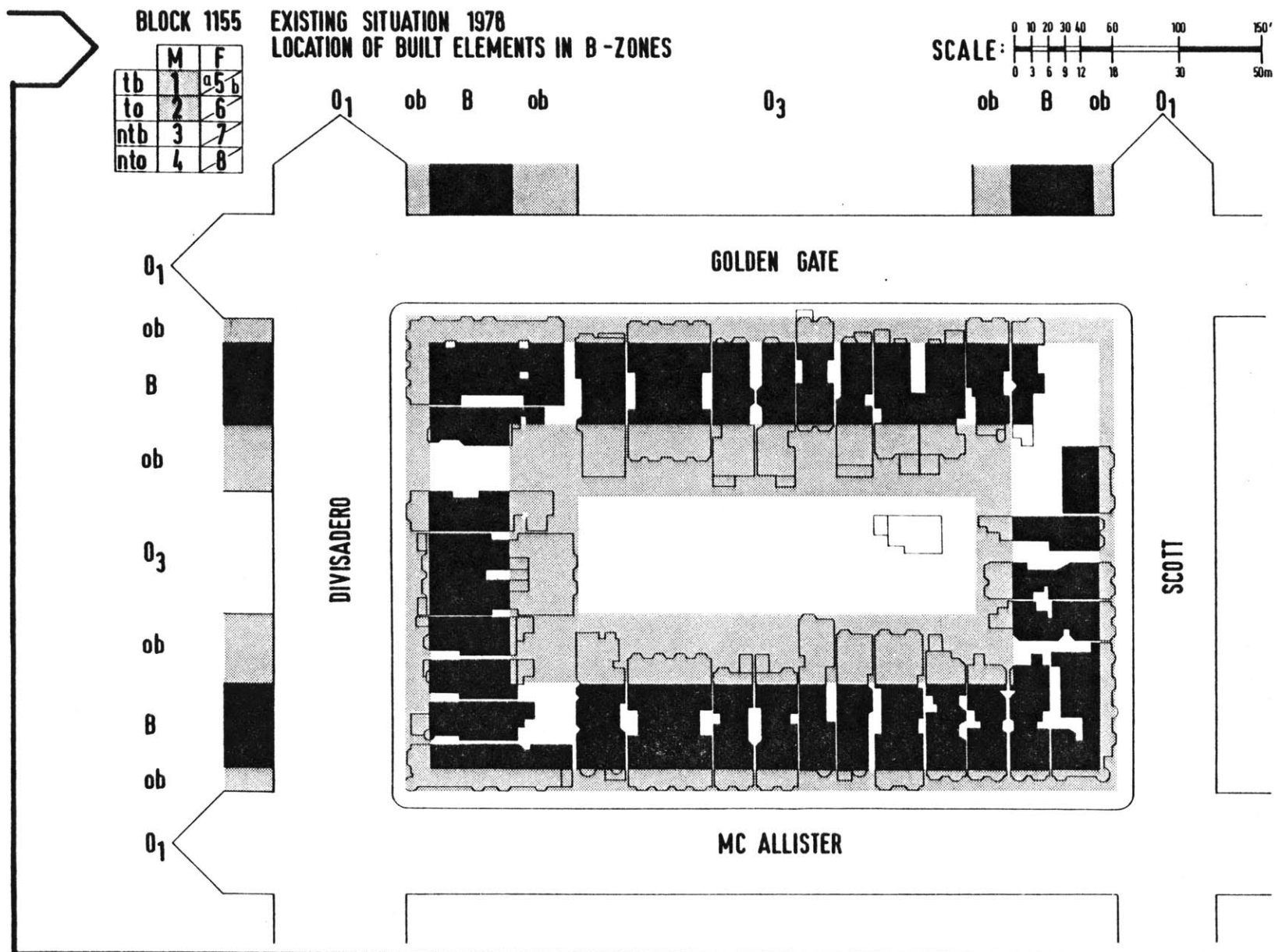

Fig. 89

Different positions of the main house in relation to front lot lot lines create a shifting margin in both the front and back and leave a zone of 50' (15 m) which contains only built elements. (Fig. 89)

The B-zone for Block 1155 is 30' (9 m) high, with a margin for an additional third floor. The generic Victorian townhouse was built with only one or two floors. Zoning regulations and the trend to build apartment buildings has increased the general building height to three main floors. Of the thirty-three buildings in Block 1155, seventeen have two main floors, fifteen have three main floors, and only one building has more than three main floors.

2.353

CHARACTERISTICS OF OB-MARGINS

The existing block fabric has two ob-margins, one in front of the buildings, the other in back. These margins have different dimensions and are characterized by different morphological elements and functions (Fig. 90).

The ob-margin between the O_1 -zone, the street, and the B-zone is the shifting margin for set-backs. In Block 1155, set-back dimensions do not vary as much as they do in other streetscapes, for example, Blocks 821 Fell, 828 Oak, and 1180 Scott (Fig. 77). Of twenty set-back locations, thirteen are set back 15' (4.5 m). Other set-back depths vary between 2' (0.6 m) and 12' (4 m).

The front ob-margin along Scott Street is 10' (3 m) deep, the depth along Golden Gate, Divisadero, and McAllister Streets is 15'

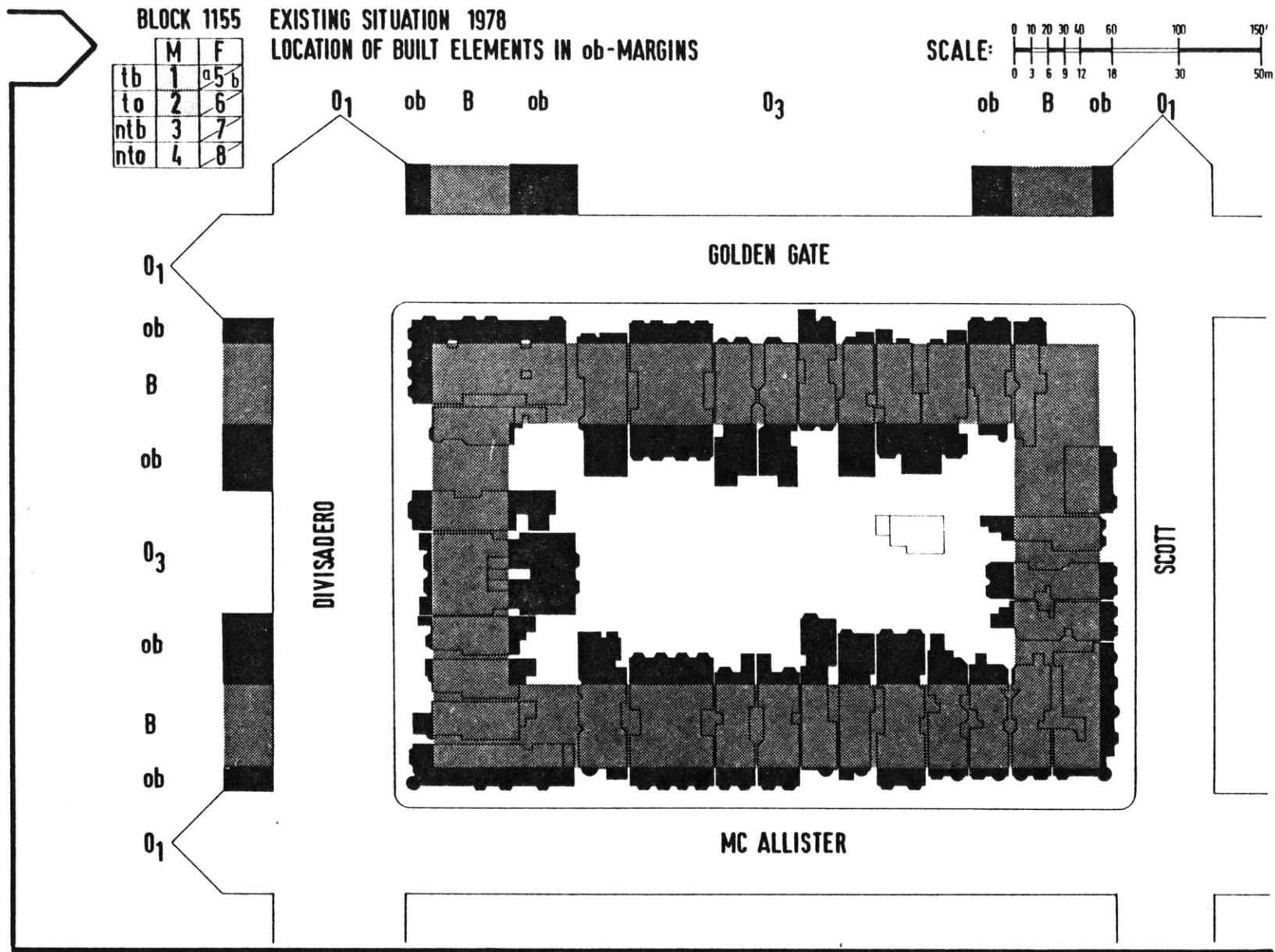

Fig. 90

(4.5 m). The front margin contains semi-public space, the space between sidewalks and front facades. Built elements in this margin face the public space; they are representative parts of the public facade of the Victorian streetscape.

Section 2.1341 summarized the complexity of functions and elements of the ob-margin in the lower level of a building. On the main floor level, bays, corner towers, balconies and fire escapes are the only elements in this margin. A building set-back of 15' (4.5 m) creates a deeper rear ob-margin. Rear ob-margins in Block 1155 are between 25' (7.5 m) and 40' (12 m) deep. As well as parts of the main house, rear ob-margins contain add-ons and fire escapes.

2.354

SAR 73 ZONING DISTRIBUTION FOR BLOCK 1155, AS NOTATED IN AN AGREEMENT SHEET

The basic morphological situation of existing block fabric can be notated without indicating buildings. This reduces the complexity of information and presents a simplified model of the distribution of built elements (Fig. 91).

Block 1155 is bounded by streets, notated O_1 in the tissue model. Golden Gate, Scott and McAllister Streets each have a width of 58'9" (17.265 m): the generic width, 68'9" (20.625 m), minus the depth of two bay windows each 5' (1.5 m) or less. For the fourth street, Divisadero, the O_1 -zone is 72'6" (21.75 m) wide, minus two bay window allowances with a maximum depth of 5' (1.5 m) each.

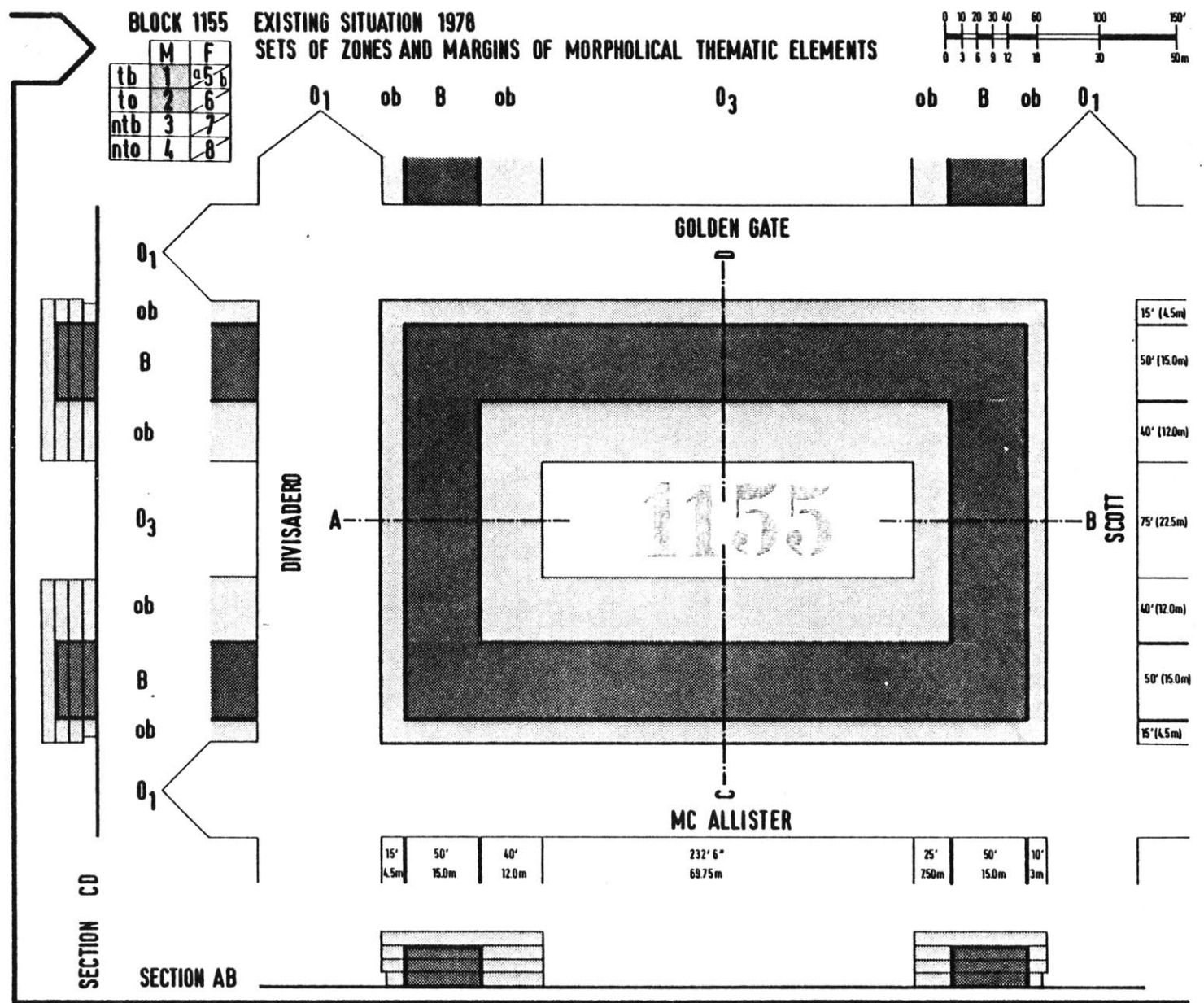

Fig. 91

2.4

GENERAL ZONING DISTRIBUTION FOR THE ALAMO SQUARE BLOCK FABRIC

Figure 91 presents a notation of the specific morphological situation for Block 1155. Elements which are not specific for the whole area, such as the extra width of Divisadero Street or a short set-back space, have been eliminated for the notation of a general zone distribution. The dimensions of the general zoning distribution are based on an analysis of several blocks in the Alamo Square area. (Fig. 92)

The following dimensions of zones and margins can be defined as thematic:

Streets are open spaces. They are notated O_1 and include space for vehicular circulation and sidewalks. O_1 -zones are 58'9" (17.265 m) wide.

O_b -margins in front of the B-zone are 15' (4.5 m) deep. B-zones are 50' (15 m) deep and have a minimum height of 30' (9 m).

O_b -margins in the back of the B-zone have an average depth of 40' (12 m). Inner courtyard space, notated O_3 , contains no built elements and is 212'6" (63.75 m) long and 75' (22.5 m) wide.

This zoning system simplifies the complexity of the existing morphology but defines basic location patterns of the block fabric around Alamo Square. It will be used as a starting point for the development of a tissue model which will be enriched with rules to regulate new developments which consider the patterns of the existing environment.

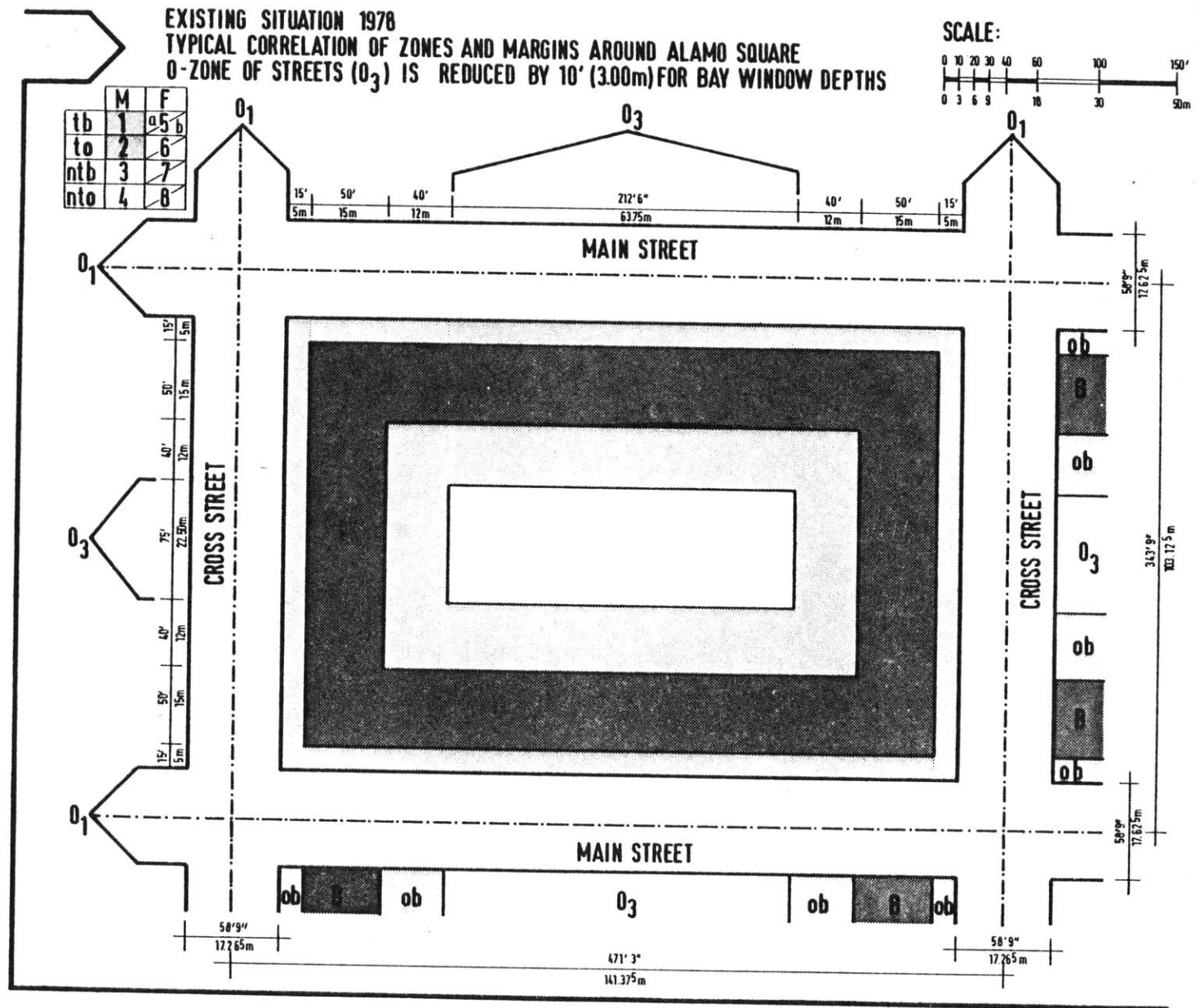
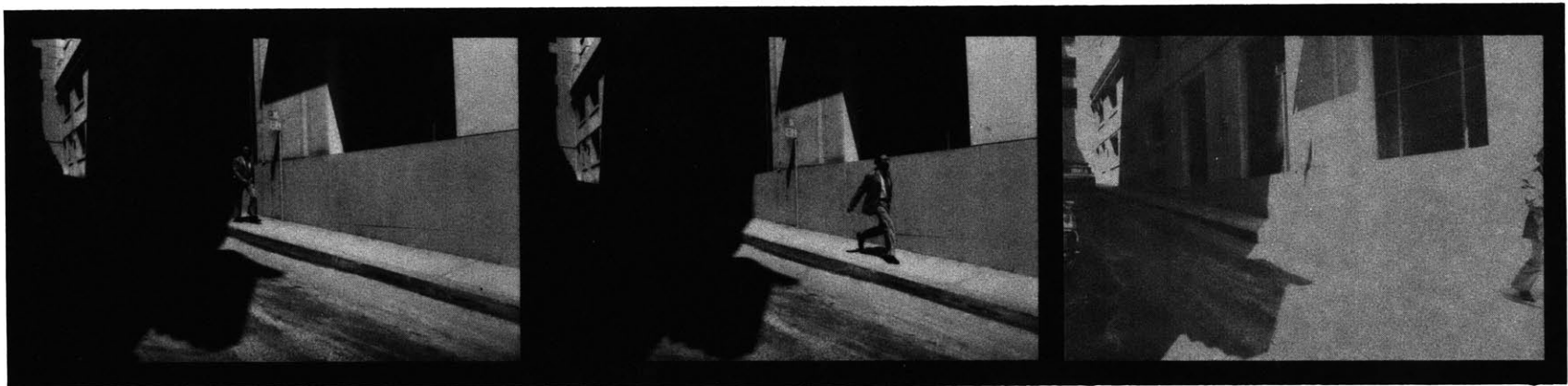

Fig. 92



3.0 DEVELOPMENT OF A TISSUE MODEL

3.0

DEVELOPMENT OF RULES FOR TISSUE MODELS, BASED ON PRESENT DENSITY STANDARDS OF THE ALAMO SQUARE AREA, WHICH ASSIMILATE THE EXISTING MORPHOLOGY.

The following sections will document the development of tissue models, considering the characteristics of existing circulation patterns and the morphology of the Victorian block fabric.

The method presented is based on the Waldeck Study,¹ an investigation into high density allotment. This study emphasizes density quantification and concentrates on the morphological aspects of built element distribution.

Analysis of the Alamo Square block fabric indicates certain obvious morphological tissue patterns which are necessary for the use of the SAR 73 method. The arrangement of the streets for circulation is the most basic pattern of the existing tissue. Because the general proportions and dimensions of the single block area cannot be changed, this pattern will be transferred to the new tissue model. This will have a strong impact on the variety of possible arrangements of built elements in this fixed block area, as well as on the layout of additional inner circulation systems.

¹Stichting Architecten Research, Deciding on Density: An Investigation into High Density Allotment with a View to the Waldeck Area, The Hague. (Eindhoven, Holland: Stichting Architecten Research, 1977)

3.1

TISSUE TYPE GROUPS (VARIATIONS OF THE SAME BUILDING FORM OR CIRCULATION SYSTEM)

Tissue types, which exhibit the same characteristics in the location of thematic built and open elements but differ in circulation patterns or dimensions, will be combined to form a tissue type group. Tissue types of a certain kind are specific to the fabric of the Western Addition. This will be taken into consideration in the development of the tissue model.

The Waldeck study differentiates two tissue types: closed building blocks with courtyards and open building blocks.² Closed building blocks with courtyards are predominate in the Alamo Square area. They are present in three variations: the closed building block without an alley, with a short alley, or with a long alley. (See section 2.121 for a discussion of these block configurations.)

These three tissue types and a proposed version of a closed building block with an infill support structure for renewal developments are combined to form Tissue Type Group I. Tissue Type Group II includes four types of open building blocks. Tissue Type Group III presents a combination of closed and open building blocks with alley circulation parallel to major streets. Tissue Type Group IV includes examples of closed and open building blocks with diagonal alley circulation.

²Ibid., p. 29

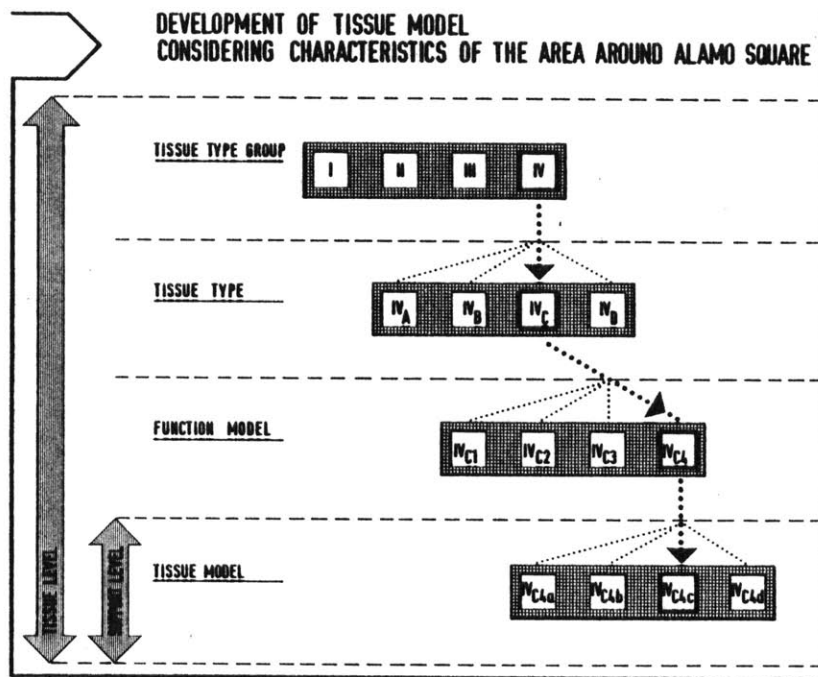

Fig. 93

Four function models are developed schematically for each tissue type and will be later specified and evaluated in tissue models. (Fig. 93)

3.2

TISSUE TYPES

The existing tissue types, Group I, present only one possibility for the development of tissue models. The present closed building block pattern is based on patterns of deep lots and deep Victorian townhouse floor plans. Because of new building standards, different life styles and new industrialized building techniques, modern residential architecture is characterized by more shallow floor plans. The application of shallow floor plans to the new tissue model must be considered.

Besides building small scale developments in infill locations, it may be that larger areas, in the scale of one or more blocks, must be built or rebuilt. Certain parts of these new developments will have no confrontation with the Victorian fabric. This may enable the use of tissue models which are not based exclusively on the Victorian closed building block morphology.

Although the closed building block type will be given preference for the development of infill tissue models, the following schematic survey of tissue types includes open built blocks and combinations of closed and open built blocks and their function models. These different tissue types are presented and commented upon in Figures 94 to 97. Their function models are shown in Figures 98 to 105.

TISSUE TYPES CLOSED BUILDING BLOCKS (I.)

COMMENT:
 CLOSED TISSUE TYPES I_A, I_B, AND I_C, CHARACTERIZED BY THE SEPARATION OF PUBLIC STREET AREAS AND SEMI-PUBLIC COURTYARDS BY SUPPORT STRUCTURES, ARE EXAMPLES OF THE EXISTING BLOCK TISSUE PATTERN AROUND ALAMO SQUARE. TYPE I_A IS THE MOST COMMON. TYPES I_B AND I_C ARE RARE VARIATIONS OF CLOSED TISSUE TYPES, WITH AN ADDITIONAL ALLEY IN THE MIDDLE OF THE BLOCK TO PROVIDE VEHICULAR ACCESS TO SUPPORTS LOCATED IN THE CENTER. THE EXISTING PATTERNS SHOW ONLY ONE ALLEY; A COMBINATION OF ALLEYS IN BOTH DIRECTIONS IN ONE GENERIC BLOCK DOES NOT EXIST.
 TISSUE TYPE I_D IS A VARIATION OF I_C. THE CLOSED BLOCK FRAME MAY HAVE AN INFILL OF ONE OR TWO OPEN BUILDING BLOCKS TO INCREASE THE NUMBER OF UNITS. AS IN TYPE I_C, AN ALLEY PROVIDES VEHICULAR CIRCULATION IN ONE DIRECTION. SEMI-PUBLIC PATHS ORGANIZE PEDESTRIAN CIRCULATION IN THE COURTYARDS.
 HERE, TISSUE TYPES ARE PRESENTED SCHEMATICALLY. POSITIONS OF SUPPORT STRUCTURES AND CIRCULATION ELEMENTS CAN VARY, RELATING TO BUILDING HEIGHT, AND ARRANGEMENT OF OPEN PARKING AREAS AND PLAYGROUNDS.

ELEMENTS OF TISSUE TYPES:

- PATHS
SEMI-PUBLIC FOR PEDESTRIAN USE ONLY (OPTIONAL)
- ▬▬▬▬▬▬▬▬▬▬▬▬▬▬▬▬ BUILT ZONES (BUILT/OPEN MARGINS NOT CONSIDERED)
- ▬▬▬▬▬▬▬▬▬▬▬▬▬▬▬▬ MAIN STREETS
- ▬▬▬▬▬▬▬▬▬▬▬▬▬▬▬▬ VEHICULAR CIRCULATION IN TWO DIRECTIONS
- ▬▬▬▬▬▬▬▬▬▬▬▬▬▬▬▬ ALLEYS WITH VEHICULAR CIRCULATION IN ONE DIRECTION

I_A

THIS IS THE MOST TYPICAL BLOCK PATTERN FOUND AROUND ALAMO SQUARE. VEHICULAR CIRCULATION IS PROVIDED IN TWO DIRECTIONS BY MAIN AND CROSS STREETS, WITH NO ALLEYS IN THE COURTYARD FOR VEHICULAR CIRCULATION. A PATH IN THE COURTYARD PROVIDES SEMI-PRIVATE PEDESTRIAN CIRCULATION.

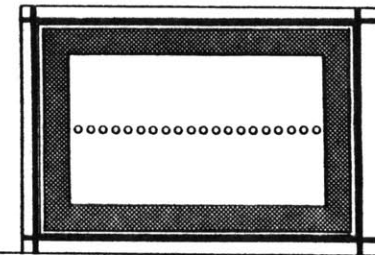

I_B

TWO FRAMES OF CLOSED BUILDING BLOCKS. ADDITIONAL VEHICULAR ACCESS IN ONE DIRECTION IS PROVIDED BY AN ALLEY RUNNING PARALLEL TO THE CROSS STREETS. THERE IS A PATH FOR PEDESTRIAN CIRCULATION IN EACH COURTYARD. THIS TYPE RELATES WELL TO THE PROPORTIONS OF THE GENERIC BLOCK.

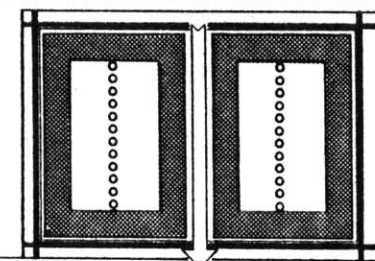

I_C

TWO FRAMES OF CLOSED BUILDING BLOCKS. ADDITIONAL VEHICULAR ACCESS IN ONE DIRECTION PARALLEL TO THE MAIN STREETS. THERE ARE PATHS IN EACH COURTYARD FOR SEMI-PRIVATE PEDESTRIAN CIRCULATION. THIS TYPE DOES NOT RELATE AS WELL AS TYPE I_B TO THE PROPORTIONS OF THE GENERIC BLOCK

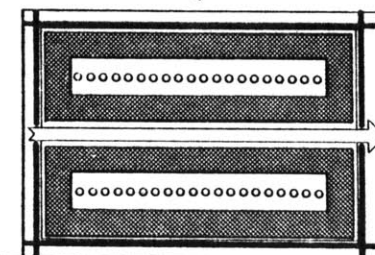

I_D

ONE CLOSED BUILDING BLOCK WITH AN OPEN BUILDING BLOCK IN THE CENTER, PARALLEL TO THE MAIN STREETS. ADDITIONAL VEHICULAR ACCESS TO THE CENTER IS PROVIDED BY AN ALLEY. PATH PROVIDES SEMI-PRIVATE PEDESTRIAN CIRCULATION IN THE COURTYARD.

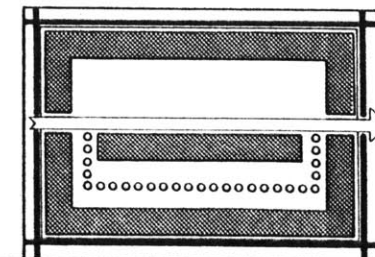

Fig. 94

TISSUE TYPES - OPEN BUILDING BLOCKS (II.)

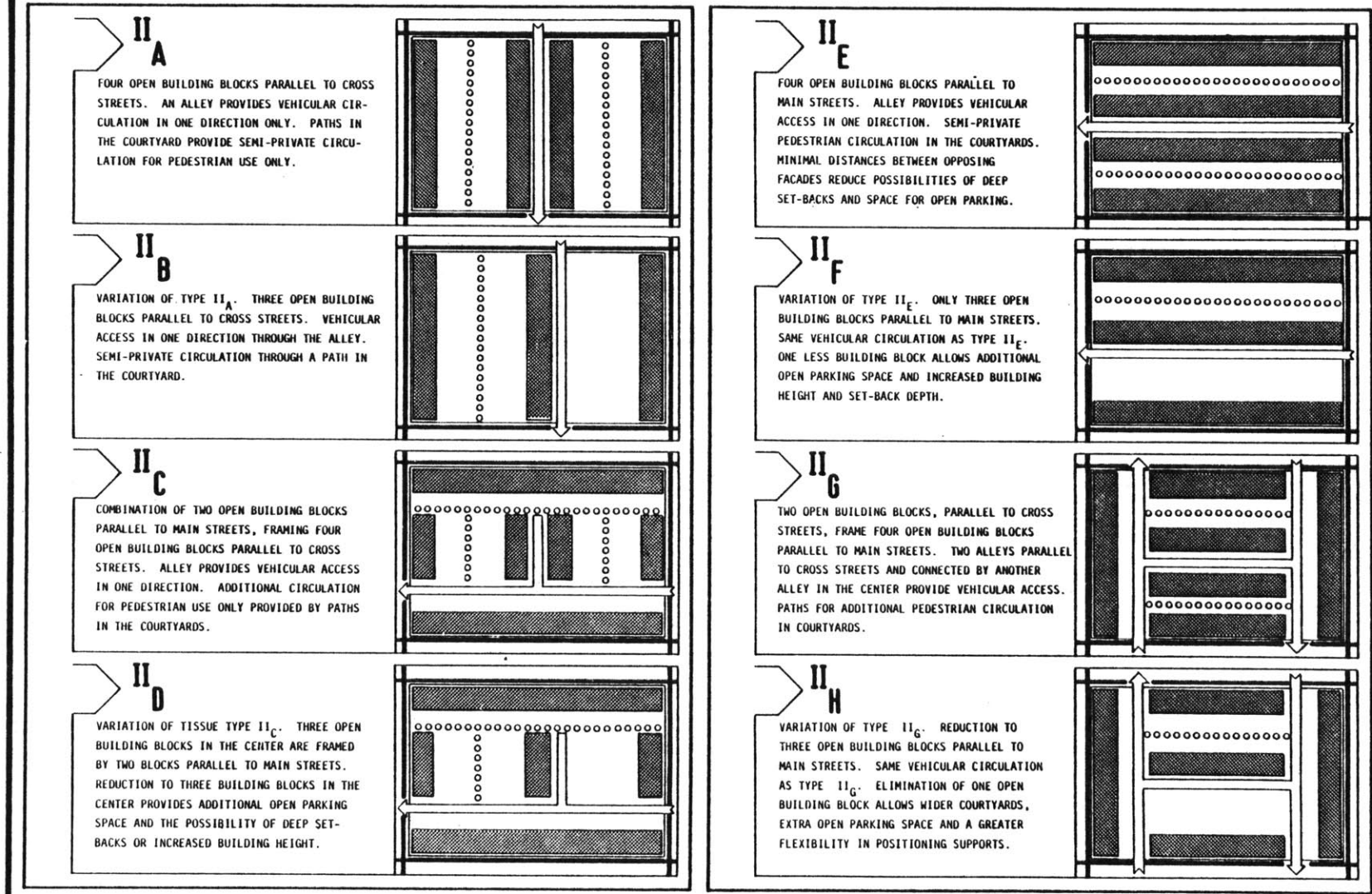

Fig. 95

TISSUE TYPES - COMBINATIONS OF CLOSED AND OPEN BUILDING BLOCKS WITH STRAIGHT ALLEY CIRCULATION (III)

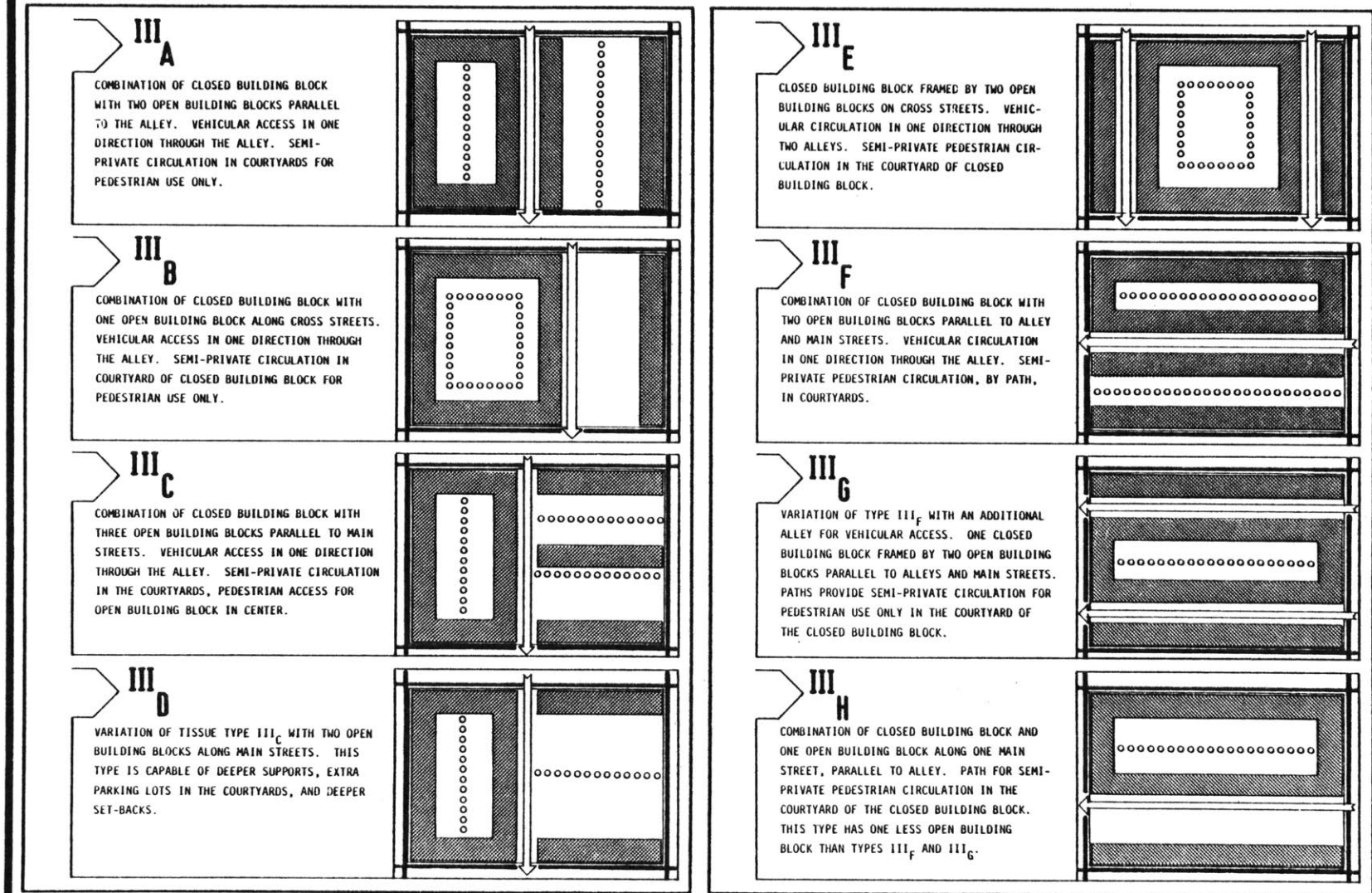

Fig. 96

TISSUE TYPES COMBINATIONS OF CLOSED AND OPEN BUILDING BLOCKS WITH DIAGONAL ALLEY CIRCULATION (IV)





COMMENT:

COMBINATIONS OF CLOSED AND OPEN BUILDING BLOCKS WITH DIAGONAL ALLEY CIRCULATION ARE CHARACTERIZED BY A CHANGE IN DIRECTION OF THE ALLEY IN THE INNER BLOCK. THIS MAKES IT POSSIBLE TO SLOW DOWN VEHICULAR TRAFFIC AS WELL AS TO ARRANGE BUILT ZONES INSIDE THE BLOCK WHICH FRAME OPEN INNER SPACES OF VARIOUS SHAPES.

THE NUMBER OF BUILT ZONES MUST RELATE TO THE PROPORTIONS OF THE GENERIC BLOCK TO ALLOW SUFFICIENT SET-BACK MARGINS FOR ALL BUILT ZONES AND GUARANTEE NECESSARY OPEN OUTDOOR SPACES BEHIND SUPPORTS. THE VARIETY OF SHAPES OF INNER OUTDOOR SPACES IMPLIES A VARIETY OF ARRANGEMENTS FOR PARKING AREAS, PUBLIC GREENS AND PLAYGROUNDS.

THESE TISSUE TYPES SEPARATE MOST OF THE INNER SPACE OF THE BLOCK FROM THE MAIN STREETS BY BUILT ELEMENTS. THEIR ELEVATION TO THE MAIN STREETS FUNCTIONS AS A WALL. BUILT ELEMENTS FRAME THE INTERIOR COURTYARDS.

ELEMENTS OF TISSUE TYPES:

-  BUILT ZONES (BUILT/OPEN MARGINS NOT CONSIDERED) - LOCATION
-  MAIN STREETS WITH VEHICULAR CIRCULATION IN TWO DIRECTIONS
-  ALLEYS WITH VEHICULAR CIRCULATION IN ONE DIRECTION
-  PATHS - SEMI-PUBLIC FOR PEDESTRIAN USE ONLY (OPTIONAL)

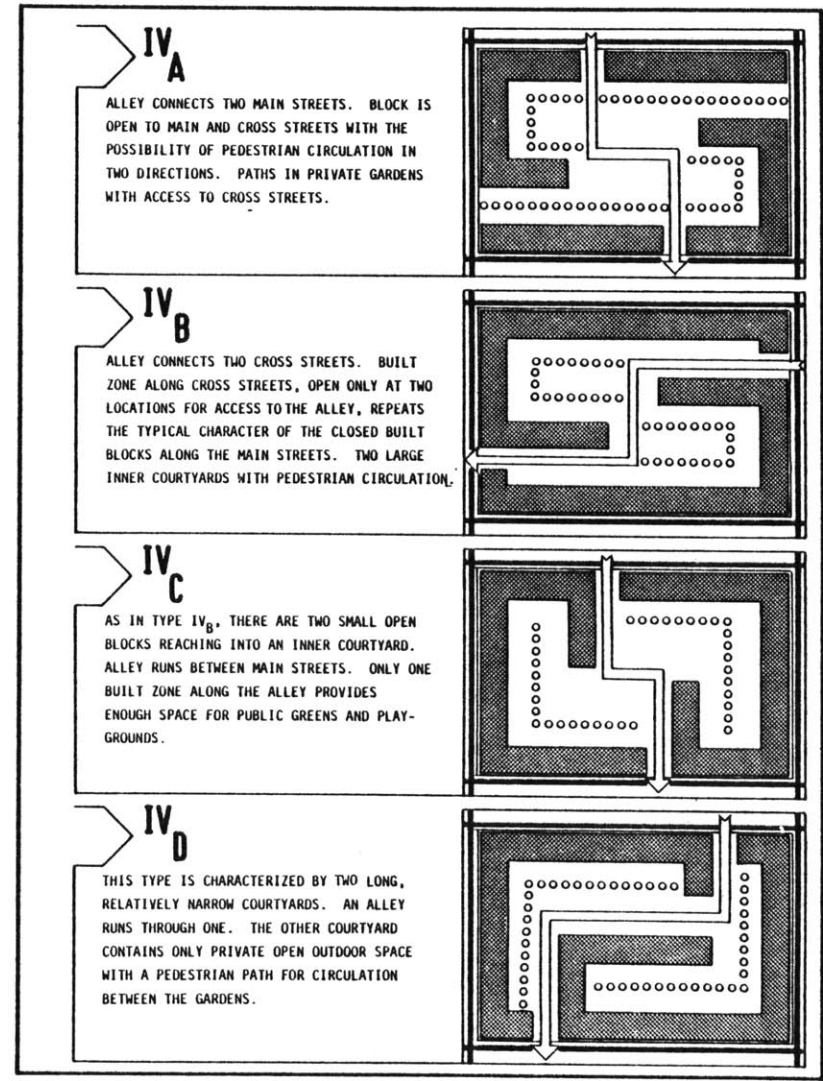

Fig. 97

3.3





**FUNCTION MODELS
OF TISSUE TYPES**

TISSUE TYPES CHARACTERIZE THE INTERWEAVING OF BUILT AND OPEN ELEMENTS IN RELATION TO THEIR BASIC FUNCTIONAL REQUIREMENTS, FOR EXAMPLE, THE LOCATION OF BUILT ELEMENTS AND PLACEMENT OF CIRCULATION SYSTEMS FOR VEHICLES AND PEDESTRIANS. FUNCTION MODELS FURTHER SPECIFY HOW THE TISSUE TYPES WORK. CERTAIN ADDITIONAL FUNCTIONS SUCH AS PARKING, PUBLIC GREEN AREAS, AND PRIVATE GARDENS WILL BE INDICATED IN THE TISSUE MODELS.

THE DEVELOPMENT OF FUNCTION MODELS FOR TISSUE TYPES I, II, AND IV SHOW DIFFERENT LOCATIONS AND CORRELATION POSSIBILITIES FOR THESE OPEN AND BUILT ELEMENTS. PRESENTATION OF PARKING ALTERNATIVES HAS PRIORITY IN THE FOUR FUNCTION MODELS FOR EACH TISSUE TYPES. CRITERIA FOR FUNCTION MODELS ARE DESCRIBED IN THE RIGHT-HAND SECTIONS OF EACH COLUMN. ALTHOUGH FUNCTION MODELS ARE RESTRICTED IN THIS BLOCK SCALE STUDY, THE SELECTION OF CERTAIN FUNCTION TYPES CAN DEPEND ON THE FUNCTION TYPES OF ADJACENT BLOCKS SO THAT A RELATION TO THESE ADJACENT BLOCKS IS MAINTAINED.

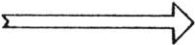
TISSUE TYPE GROUP III, COMBINATIONS OF CLOSED AND OPEN BUILDING BLOCKS WITH STRAIGHT ALLEY CIRCULATION, CONTAINS COMBINATIONS OF FUNCTION MODELS FROM TISSUE TYPES I AND II. THEREFORE, FUNCTION MODELS FOR THIS TYPE GROUP ARE NOT LISTED SEPARATELY.

ELEMENTS OF TISSUE TYPES

-  MAJOR STREETS WITH VEHICULAR CIRCULATION IN TWO DIRECTIONS
-  ALLEYS WITH VEHICULAR CIRCULATION IN ONE DIRECTION
-  PATHS - SEMI-PUBLIC FOR PEDESTRIAN USE ONLY (OPTIONAL)
-  BUILT ZONES (BUILT/OPEN MARGINS NOT CONSIDERED) - LOCATION
-  PUBLIC OPEN SPACE (PUBLIC GREEN OR PLAYGROUND)
-  OUTSIDE PARKING IN FRONT OF BUILDING OR LOT

1
**PERPENDICULAR PARKING IN FRONT
OF BUILDINGS ALONG STREETS AND
ALLEYS.**

2
**PARKING ON STREET AND IN BASE
OF BUILDING.
OPEN SPACES FOR PUBLIC GREEN
OR PLAYGROUNDS.**

3
**COMBINATION OF SPACES FOR OUTDOOR
PARKING AND PUBLIC GREEN.
SPECIFIC TO CHARACTERISTICS OF
TISSUE TYPE.**

4
**COMBINATION OF SPACES FOR OUTDOOR
PARKING AND PUBLIC GREEN.
SPECIFIC TO CHARACTERISTICS OF
TISSUE TYPE. ALTERNATIVE TO 3.**

FUNCTION MODELS OF TISSUE TYPES WITH CLOSED BUILDING BLOCKS (I.)

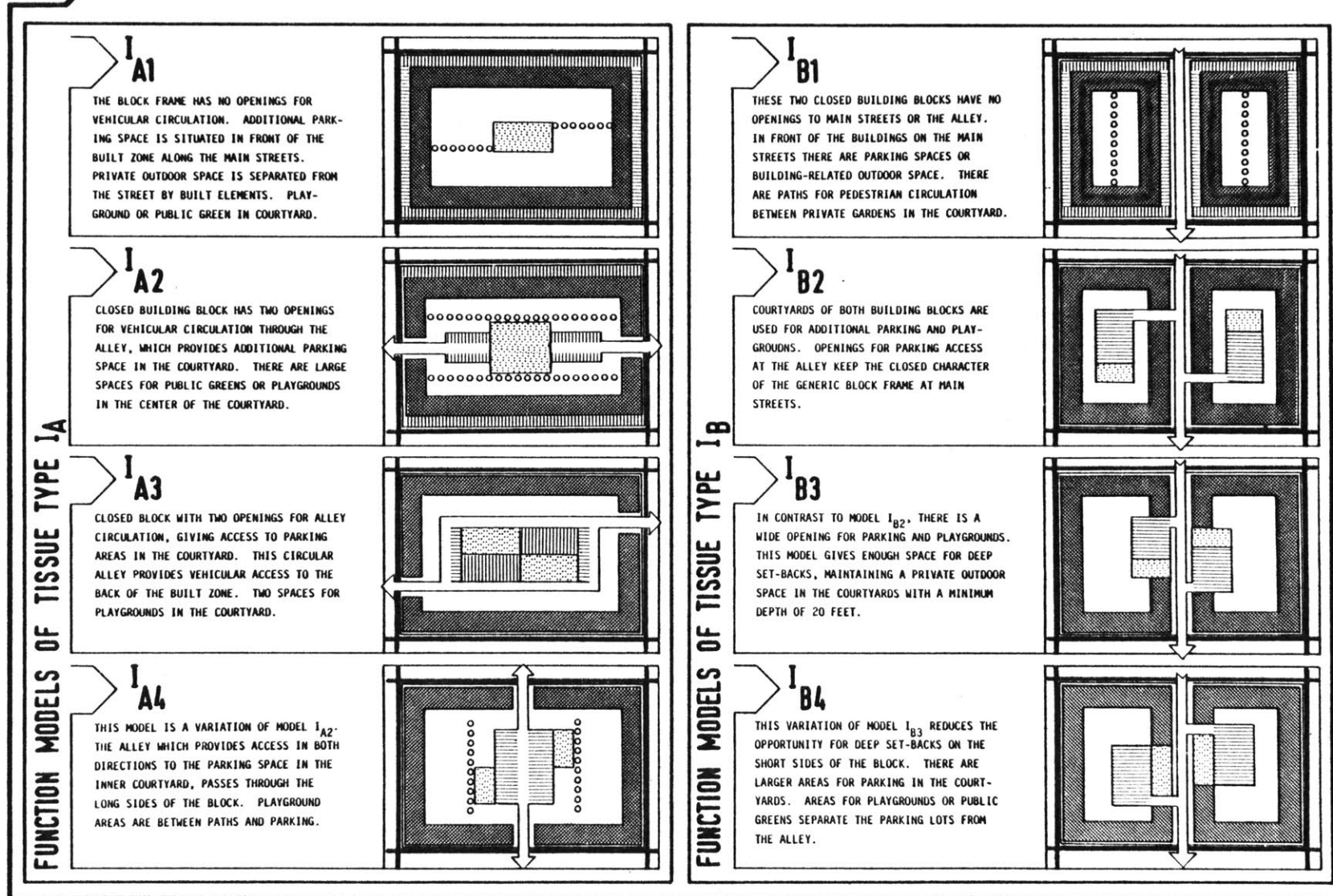

Fig. 98

FUNCTION MODELS OF TISSUE TYPES WITH CLOSED BUILDING BLOCKS (I.)

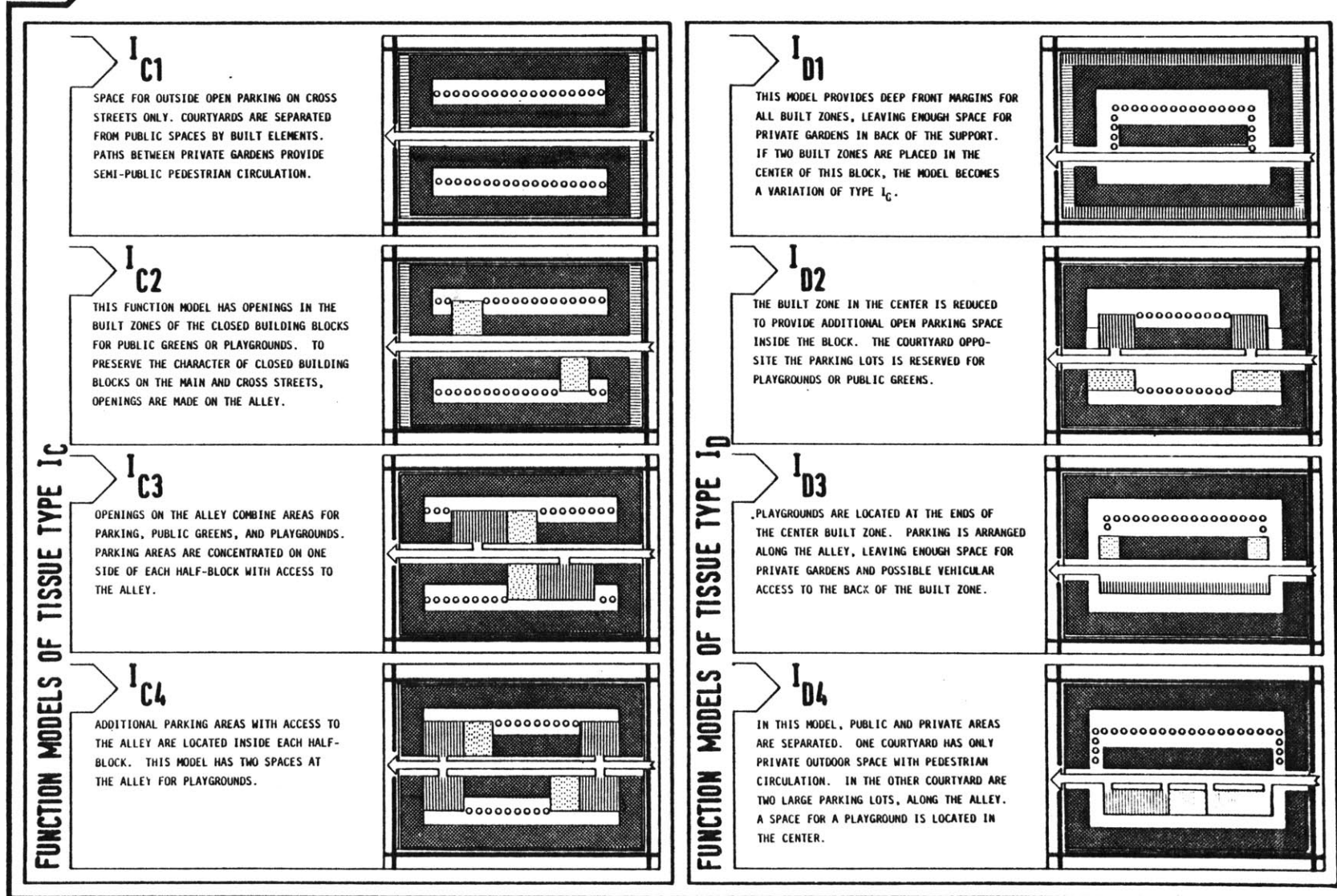

Fig. 99

FUNCTION MODELS OF TISSUE TYPES WITH OPEN BUILDING BLOCKS (II.)

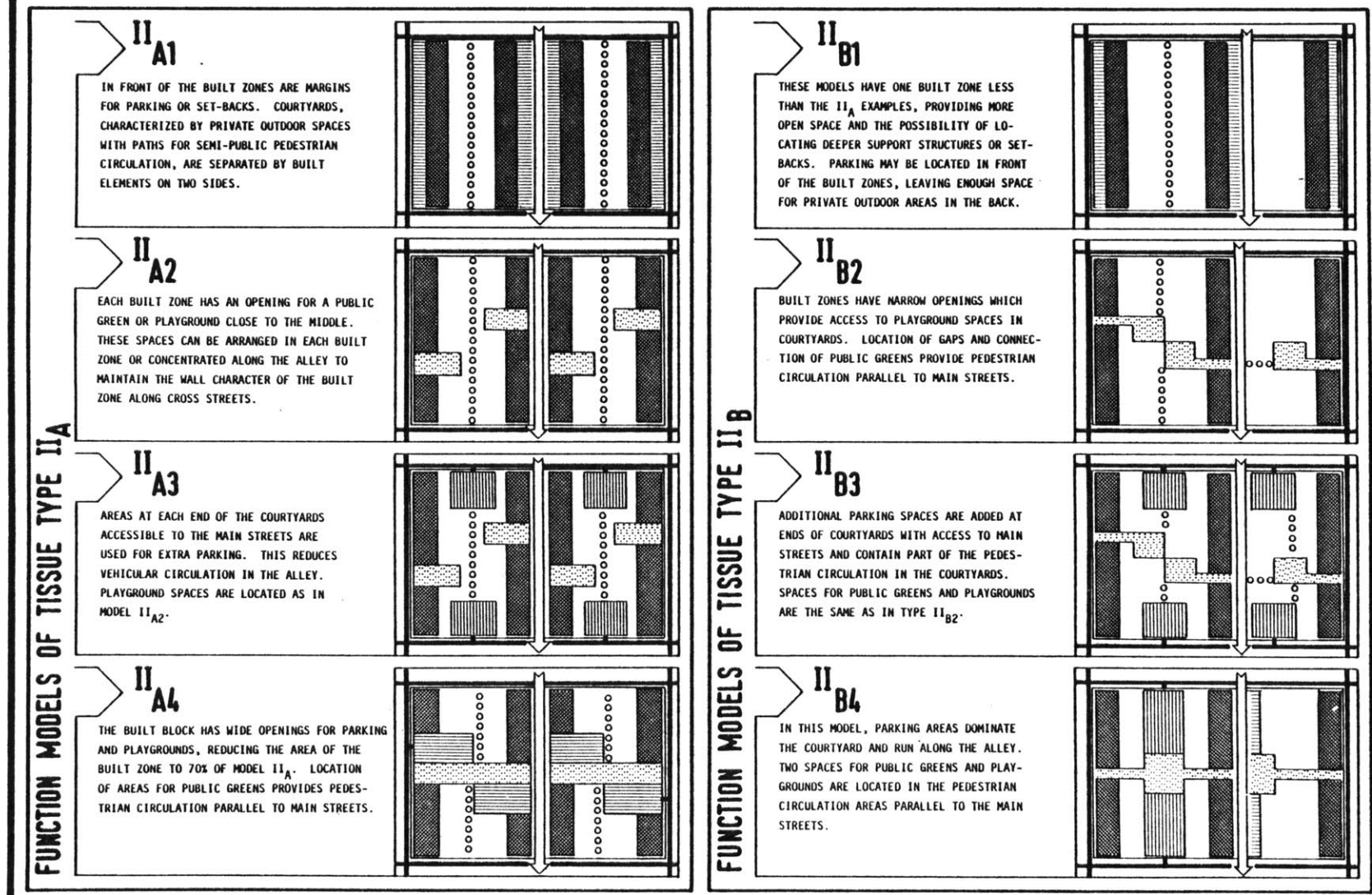

Fig. 100

FUNCTION MODELS OF TISSUE TYPES WITH OPEN BUILDING BLOCKS (II.)

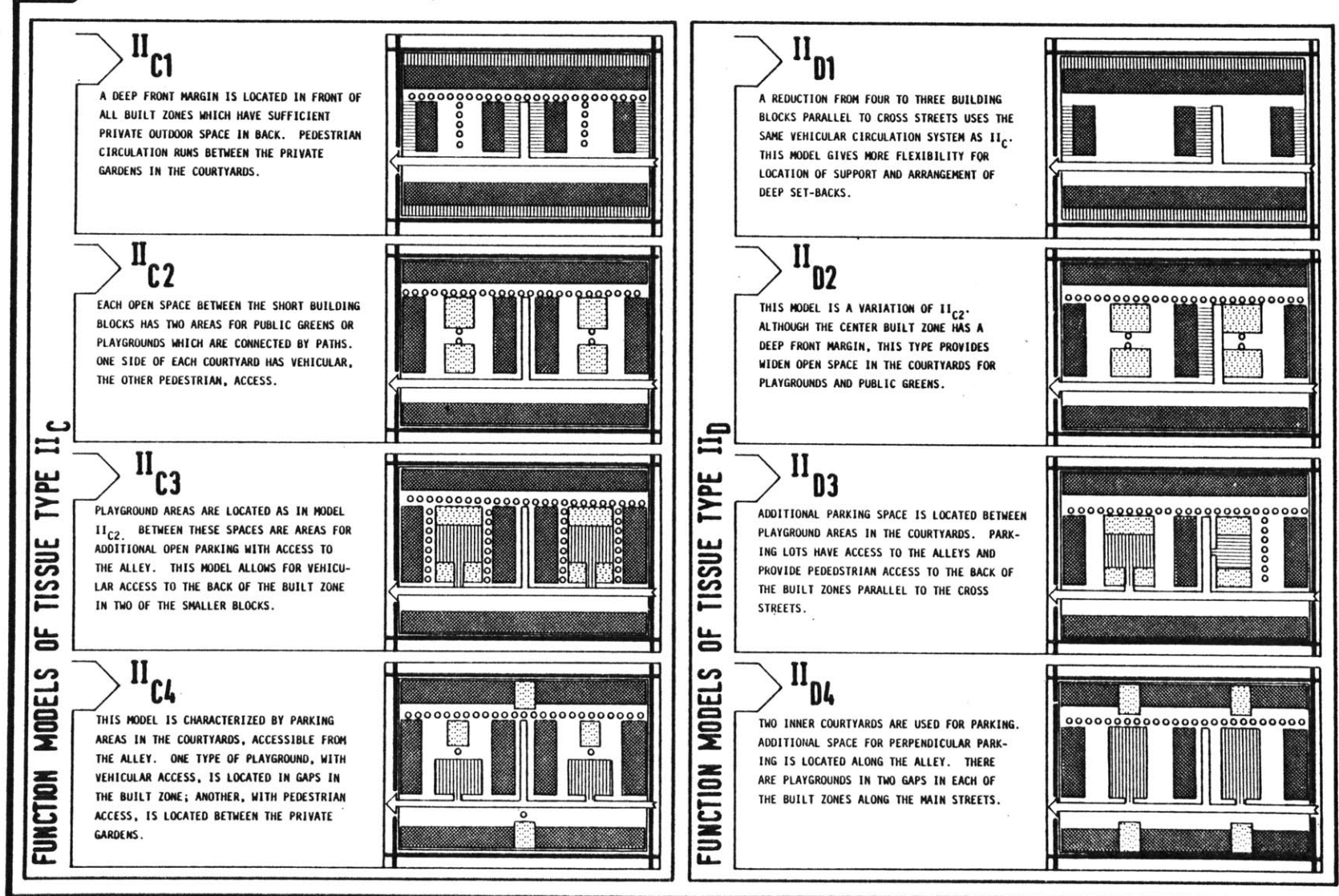

Fig. 101

FUNCTION MODELS OF TISSUE TYPES WITH OPEN BUILDING BLOCKS (II.)

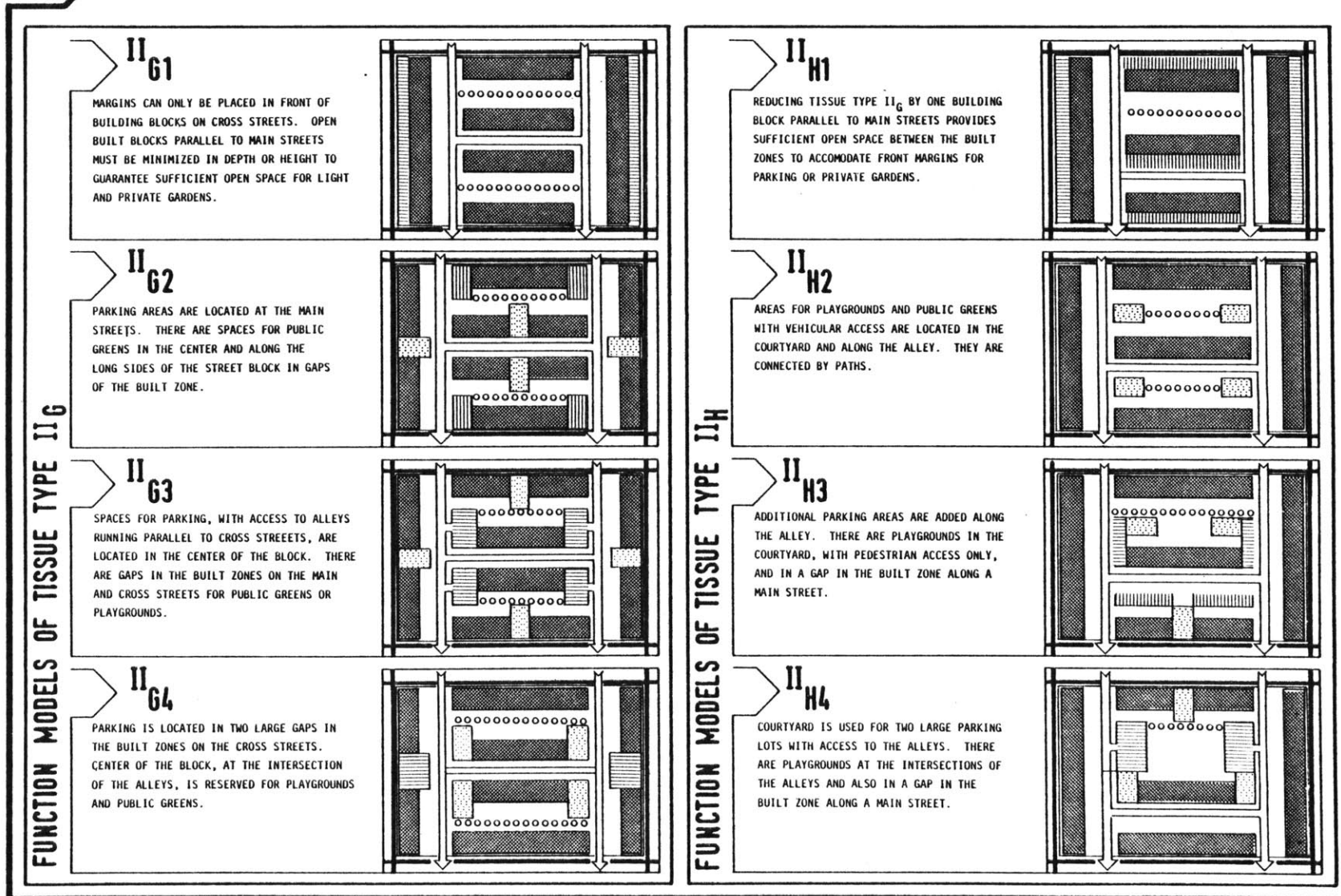

Fig. 102

FUNCTION MODELS OF TISSUE TYPES WITH OPEN BUILDING BLOCKS (II)

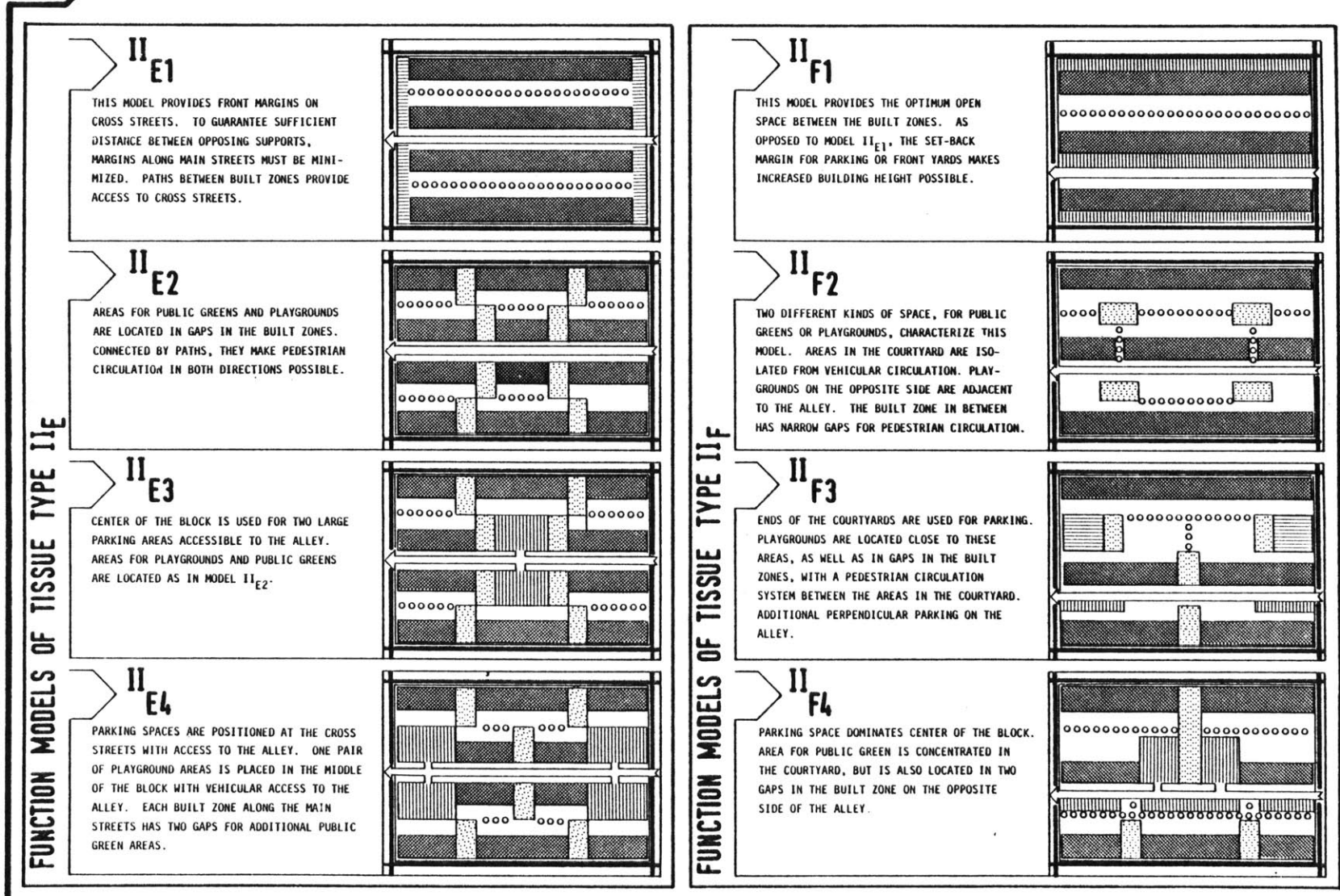

Fig. 103

FUNCTION MODELS OF TISSUE TYPES WITH OPEN AND CLOSED BUILDING BLOCKS AND DIAGONAL ALLEY CIRCULATION (IV)

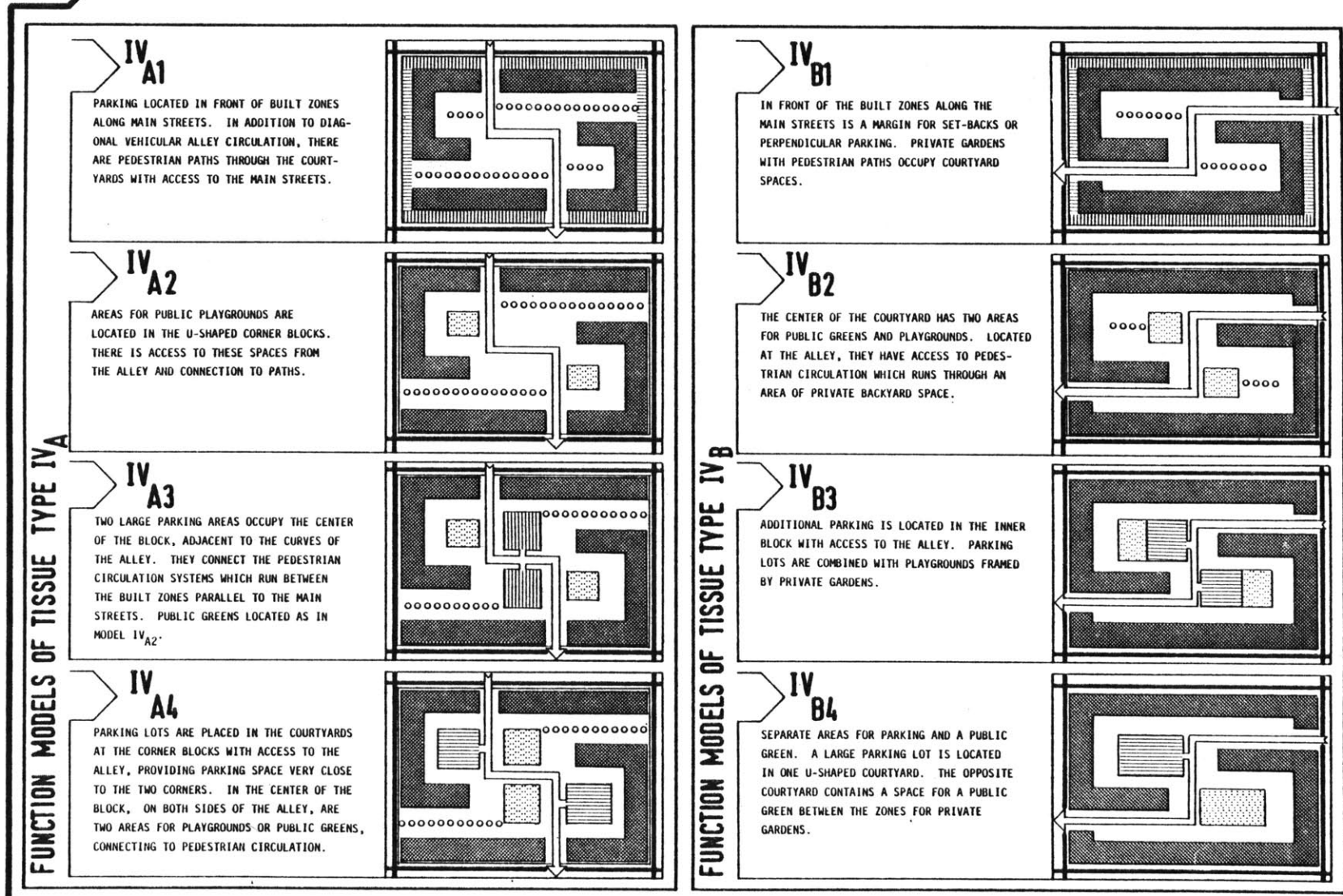

Fig. 104

FUNCTION MODELS OF TISSUE TYPES WITH OPEN AND CLOSED BUILDING BLOCKS AND DIAGONAL ALLEY CIRCULATION (IV)

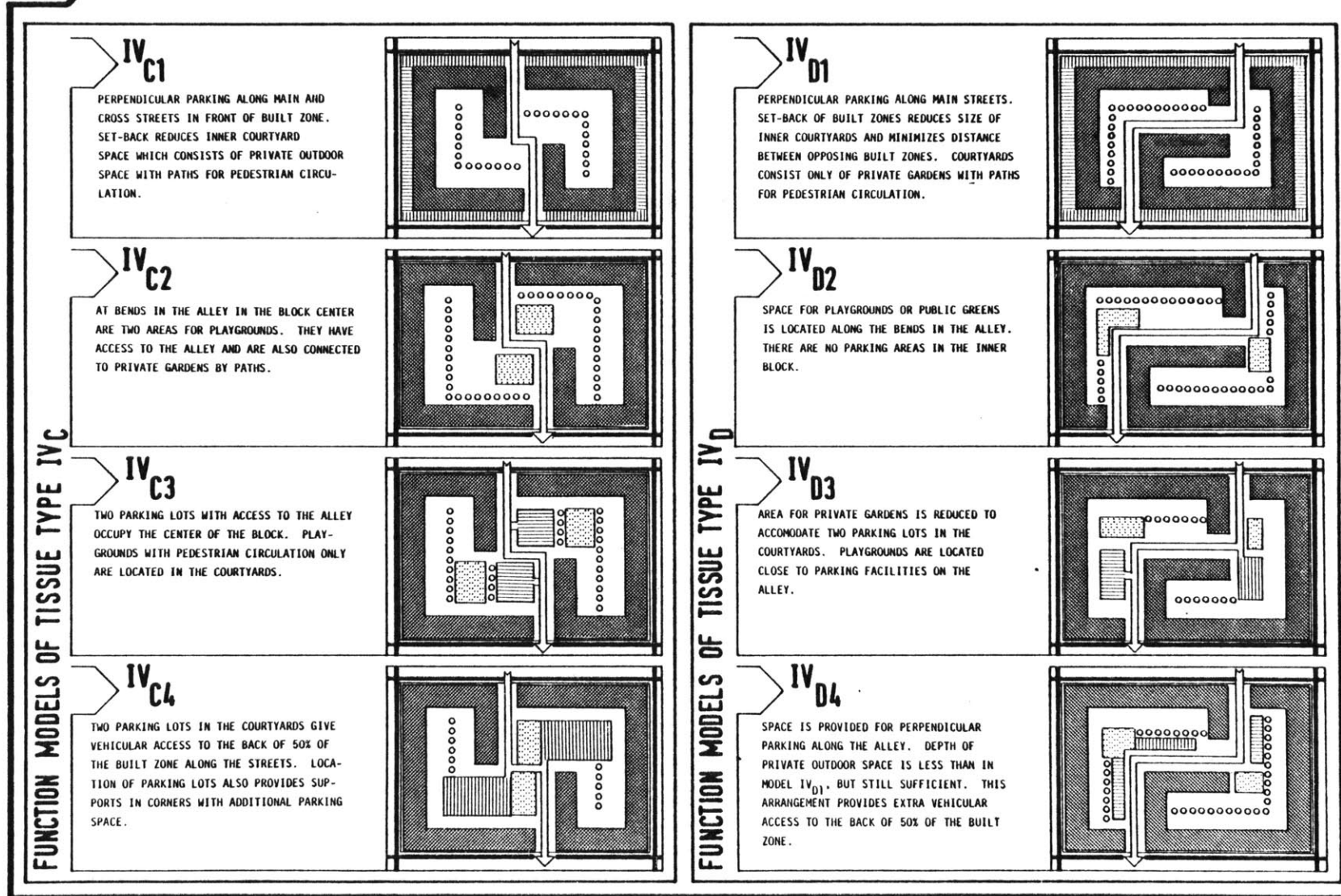

Fig. 105

Evaluation of the different tissue types and their function models must be made in relation to the specific morphological fabric of the surrounding environment. This study concentrates on adaptation to the Victorian tissue patterns, but does not exclude the possibility of using tissue types with a less closed built morphology. Choice of a preferred tissue type depends on the analysis of existing neighboring block fabric, topography, type of development (public or private), and circulation patterns.

The new tissue model should assimilate the characteristics of the Victorian fabric, if new developments will be confronted with these characteristics and become a part of this tissue. The general requirements for the development of such a model are the repetition of the closed built block character and transfer of the dominant morphological criteria of the Victorian streetscape.

These constraints can be regulated by a set of agreements which allow a morphological adaptation, on the tissue scale as well as on the support and sector (single dwelling) scale. The following proposed set of rules for a tissue model differentiates these two levels. The nineteen rules provide regulations on the tissue level (Rules 1 to 7) and on the level of correlation and morphology of supports (Rules 8 to 18).

3.4

TISSUE MODELS

3.41

RULES FOR A TISSUE MODEL — PROPOSAL FOR A FORMULATION OF STANDARDS

3.411

GENERAL RULES DEFINING LOCATION AND DIMENSIONS OF ZONES AND MARGINS

Development of rules for circulation elements. The rules for a tissue model regulate locations and dimensions of thematic elements. A tissue model does not reflect a specific site, but includes general determinations which form a basic set of agreements. A model must later be adapted to a specific site, relating to local criteria such as existing tissue elements, topography, and main vehicular circulation.

The area around Alamo Square is characterized by a perpendicular street grid which is the skeleton of the existing circulation system and influences the location of built elements.

Dimensions of existing major streets. Streets which run between generic blocks of the size 412'6" x 275' (123.75 m x 82.5 m) are defined in this study as major streets. These streets have a width of 68'9" (20.65 m) from lot line to lot line. Analysis shows that the general street grid (axes of major streets) is a perpendicular one with dimensions of 481'3" x 343'9" (144.375 m x 103.125 m). (Fig. TR 1)

**DIMENSIONS OF STREET GRID
(AXIS OF O₁ ZONES)**

TR 1

**GENERAL
DIMENSIONS**

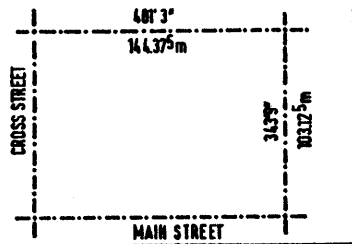

TR 2

**VARIATION
NO. 1**

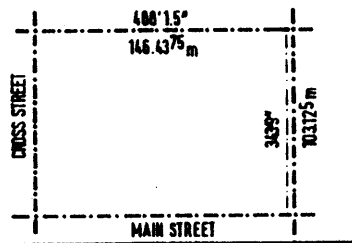

TR 3

**VARIATION
NO. 2**

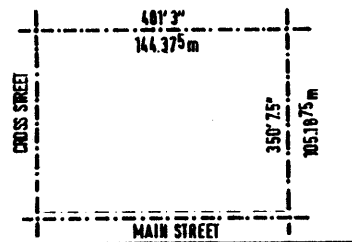

TR 4

**COMBINATION
OF VARIATION
NO. 1 AND NO. 2**

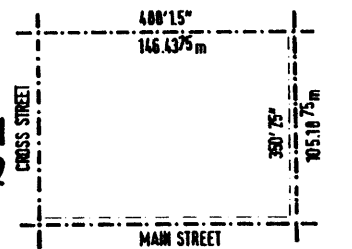

Some important streets such as Divisadero are 82'6" (24.75 m) wide. In this study, these streets are non-thematic but must be considered for the application of the tissue model. Wider major streets may be either main streets or cross streets.

The following street grid dimensions can be found around Alamo Square:

Most blocks are organized on a street grid of 481'3" x 343'9" (144.375 m x 103.125 m). (Fig. TR 1)

If a cross street on one side of a block has a width of 82'6" (24.75 m) and the width of the other three streets is the standard 68'9" (20.65 m), the dimensions of the grid are 488'15" x 343'9" (146.4375 m x 103.125 m). (Fig TR 2)

If a main street on one side of a block has a width of 82'6" (24.75 m) and the width of the other three streets is the standard 68'9" (20.625 m), the dimensions of the grid are 481'3" x 350'7.5" (144.375 m x 105.1875 m). (Fig. TR 3)

If two adjacent major streets have a width of 82'6" (24,75 m), the dimensions of the grid become 488'1.5" x 350'7.5" (146.4375 m x 105.1875 m) (Fig. TR 4)

Because wider streets are found only occasionally, they are of no importance for the development

of the tissue model, but the tissue model must be flexible to permit adaptation by transformation to other dimensions of the street grid.³

A basic agreement of the tissue model is to relate to the thematic vehicular circulation systems of major streets. This agreement in general determines the dimensions of the tissue model.

Rule 1: The existing perpendicular grid of major street axes with the dimensions of 481'3" x 343'9" (144/375 m x 103.125 m) must be maintained for existing vehicular circulation functions. If there are variations in the dimensions of the existing street grid, the tissue model must be adapted by transformation.

Major streets are thematic spatial elements of the tissue model. Dimensions of the grid do not define exactly the width of this kind of element. Different arrangements for parking and different heights of adjacent built elements may influence the width of an element. A study of circulation and parking possibilities in combination with the height of adjacent built elements shows a possible minimum width of 48' (14.4 m) for major streets. This dimension excludes the depth of bay window areas.⁴

³For a discussion of transformation, see SAR 73, section VI.3

⁴For further discussion, see the section on the public facade in the report, "Urban Form and Change."

Rule 2: Major streets will have a minimum width of 48' (14.4 m) and a maximum width of 88' (26.4 m) in relation to the specific forms of street parking and the height of adjacent built elements. Major streets are coded "0₁" in the tissue model.

The existing vehicular circulation system is not restricted to major streets but includes long and short alleys which run through the center of the blocks, parallel to main or cross streets. The proposed tissue model will include the possibility of providing vehicular access to the inner block.

In general, alleys should provide one way traffic and parking along the sidewalk on one or two sides, depending on whether the alley is single or double loaded. As with major streets, width is a function of the height and orientation of adjacent built elements. In contrast to the criteria for major streets, an additional criterion must be mentioned for alleys: analysis of existing blocks shows the dominance of a closed building block character with only a few openings for access, private gardens or parking. If this character is repeated in the tissue model, the opening in the block for an alley must be narrow.

Topography is an important criterion for the San Francisco region.⁵ An alley running parallel to a slope has advantages

⁵For a discussion of the relationship between the perpendicular street grid and the steepness of San Francisco hills, see the report, "Urban Form and Change."

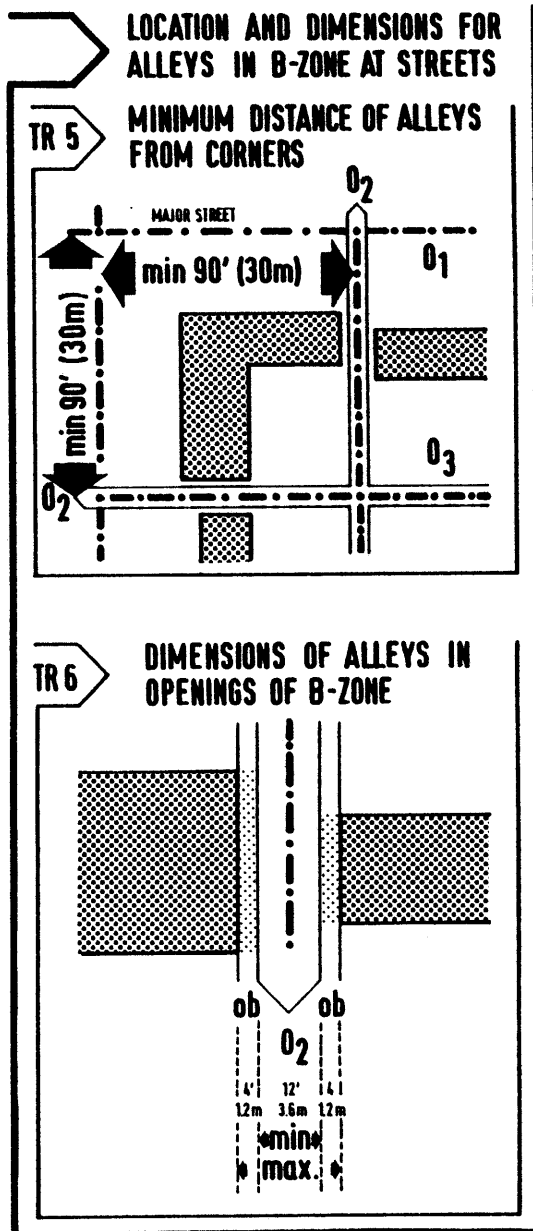

for vehicular circulation and parking. On the other hand, positioning an alley perpendicular to a slope generates an interesting variety of base and roof relations. Decisions about the orientation of an alley relative to a slope cannot be generalized, but will depend on both the steepness of the slope and the character of the neighborhood.

In the existing situation, an alley is always located in the center of a block, parallel to one of the major streets. To provide more flexibility, the proposed tissue model will not require a central location for an alley. In order to preserve the character of a closed block, the opening for an alley must not be located at a corner having a major wall function. The tissue model provides a minimum distance from the corner for all alleys.

Rule 3: Alleys must be located with their axes a minimum of 90' (30 m) from the nearest major street axis parallel to the alley (Fig. TR 5). At the opening of the B-zone along a major street, an alley may have a maximum width of 20' (12' plus 2 x 4' for bay windows in the ob-margin [Fig. TR 6]). Built elements will have no major orientation to an alley at the

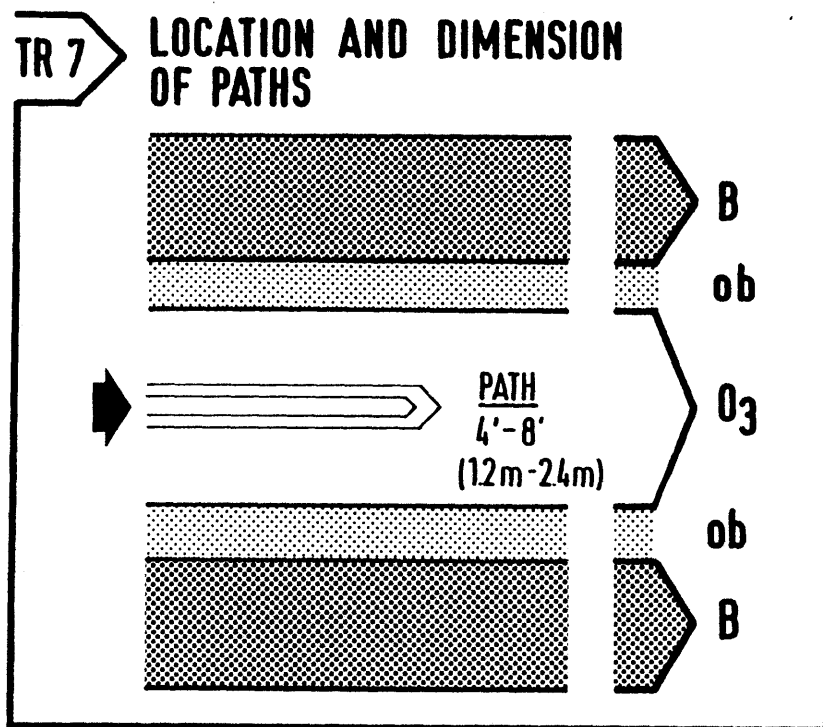

opening of the block. Inside the block, the width of an alley may vary, according to orientation, parking systems, number of building elements along the alley, and building height (from 36' [10.80 m] to 56' [16.80 m]). Alleys are coded "O₂" in the tissue model.

Elements O₁ and O₂, main streets and alleys, provide vehicular and pedestrian circulation. They are a part of the open public space. In addition to these two existing circulation systems, the proposed tissue model includes the path, an element for pedestrian circulation only. A path connects private outdoor spaces.

Rule 4: Paths are an additional pedestrian circulation element connecting private outdoor spaces in courtyards. If a path provides access to major streets, the opening in the block at the street will have a maximum width of 8' (2.40 m). The width of a path in the courtyard should be between 4' (1.2 m) and 8' (2.4 m). (Fig. TR 7)

FIG. TR 8

PROPOSED TISSUE MODEL:

MINIMUM DIMENSIONS OF RESIDENTIAL SPACES WITH OPPOSITE ORIENTATION

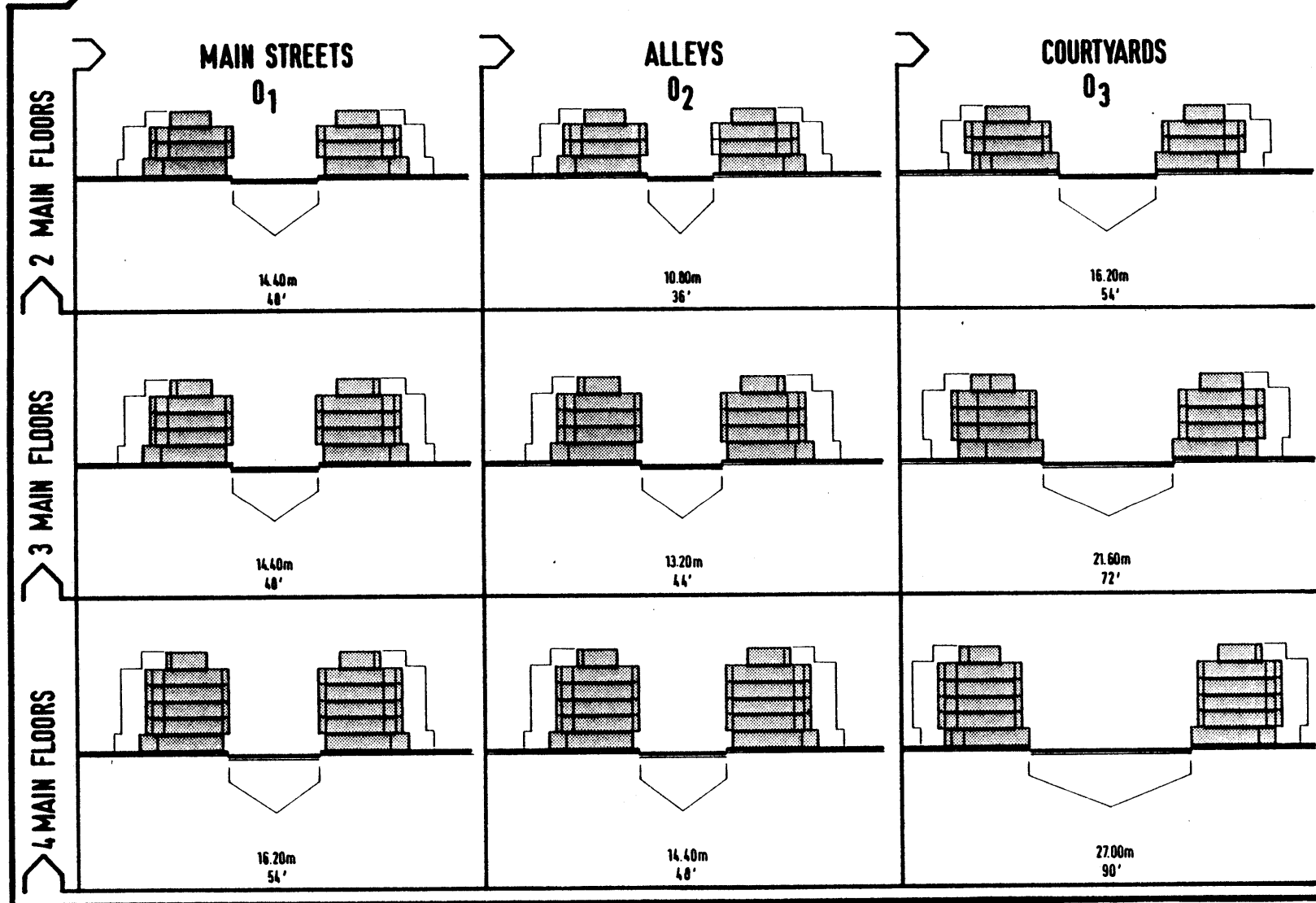

Courtyard areas may include public and private open space. For the tissue model, it is important which parts of the inner block area must remain open and which parts may be partially built. Courtyard space is defined as non-built space. Courtyard width is dependent on the height of adjacent buildings.

Rule 5: Courtyards include public and private open space. Located in the inner block, they must remain free of built elements. Courtyards are coded "O₃" in the tissue model.

Rules 1 through 5 regulate agreements about the O-zones of the tissue model. A scheme for O-zone dimensions is shown in Fig. TR 8.

Additional information about the B-zones and ob-margins is necessary to form the tissue model.

Analysis of existing block tissues around Alamo Square indicates a very differentiated structure of existing B-zones, which are characterized by various open spaces such as light wells, recesses and add-ons on the sides of built elements. A detailed description of these sub-elements will be given in the report, "Urban Form and Change," and in the rules for the support level.

In this tissue model, rules for B-zones will neglect these specifications and reduce the criteria for B-zones to those of location and dimension only. In general, B-zones are located in a pattern along major streets, closer to the street in corner locations than in intermediate locations.

A location analysis was prepared for fifty blocks around Alamo Square. The results were computed and indicated an average depth of 50' (15 m) for the B-zone.

Two significant criteria differentiate the B-zones of the existing situation from those proposed in the new tissue model: there is both a lack of lot subdivision and shorter floor plans in the proposed tissue model.

The Victorian development pattern was based on lot subdivisions of different sizes and shapes. The existing morphology was generated by a combination of Victorian floor patterns with a variety of locations. Floor plans are longer in Victorian buildings than in the proposed tissue model. Victorian buildings have a depth of up to 60' (18 m). The depth of buildings in recent developments ranges from 30' (9 m) to 40' (12 m).

To guarantee correlations between new built elements and the existing morphology, rules for the tissue must assimilate these criteria as much as possible. Detailed agreements regulating these relationships will be stated in the rules for the support level.

Existing tissue models have in common a closed built block character with an open center. Modern buildings with less floor plan depth will enlarge the inner space of the block; additional built elements may be located in this area.

Rule 6: B-zones are located along major streets and in the inner block area. B-zones along major streets have a minimum depth of 28' (8.40 m) and a maximum depth of 56' (20.1 m), depending on building and function types as well as location (corner or intermediate). The height of buildings in B-zones should be maintained as per existing buildings in the neighborhood. The height of buildings in B-zones of the inner block should not be greater than two main floors. B-zones in the inner block may be continuous because of their internal location.

One of the most interesting characteristics of the streetscape around Alamo Square is the different positions of front facades along a major street. This shifting space, where the thematic spatial element (street) and the thematic built element (support) merge, is called the ob-margin.

In the previously mentioned analysis of fifty blocks around Alamo Square, the average ob-margin depth was found to be 15' (4.5 m), ranging from a minimum depth of 4' (1.2 m) to a maximum depth of 24' (7.2 m). The minimum depth of the ob-margin is the average depth of a bay window; ob-margins of greater depth contain front gardens or areas for perpendicular parking in front of a building. In some cases, the ob-margin on the base level is used for commercial or garage space.

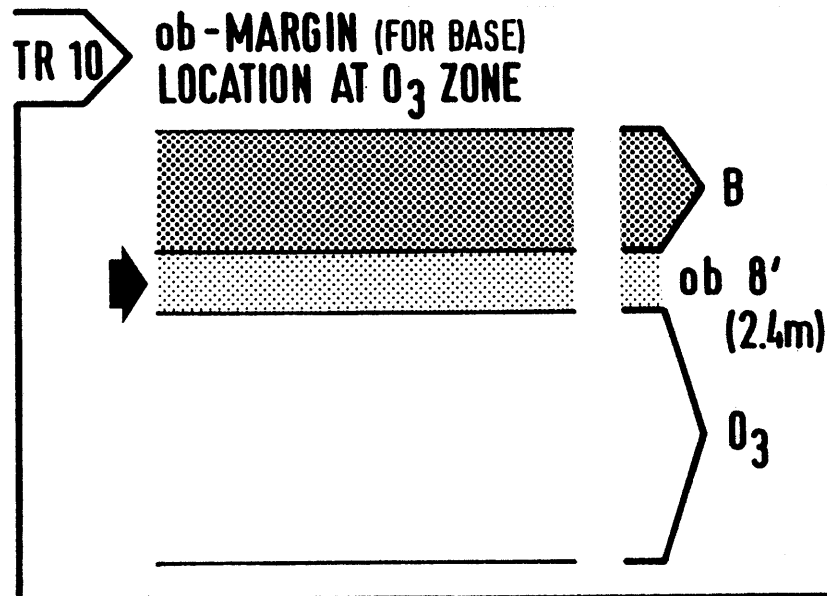
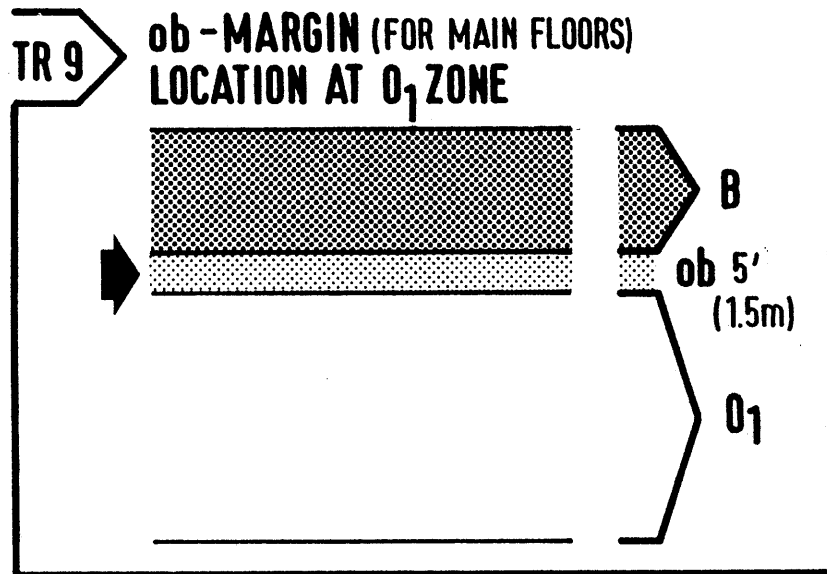

Variation in depth and location of built elements in a B-zone creates a deep ob-margin in the back along the O₃-zone as well as along the B-zone. Add-ons are built in this margin more often than along the street. If an additional B-zone is placed in the inner block, the new tissue model must reduce the depth of the ob-margin along the O₃-zone to fulfill modern requirements of ventilation, lighting, and privacy for B-zones on opposite sides of the O₃-zone.

Rule 7: Between all O-zones and B-zones there must be an ob-margin of at least 5' (1.5 m). (Fig. TR 9) Depths of the ob-margin should be differentiated based on adjacent buildings or criteria of the tissue model. For commercial use, the ob-margin must remain small (maximum of 5' [1.5 m]) For residential use, the ob-margin may be as deep as 20' (6.0 m). The ob-margin between a B-zone and an O₃-zone has a maximum depth of 5' (1.5 m) for main floors and a maximum depth of 8' (2.4 m) for the base. (Fig. TR 10) Detailed information about the differentiation of this margin

for the base and main floors is provided in the rules for the support level.

Because of the large variety of locations of B-zones in relation to the depth of ob-margins, the dimensions provided are based on individual supports for a number of support sectors with a maximum depth of thirty feet. This will enable the new tissue model to be as flexible as possible for adaptation to the existing situation.

Rules 1 to 7 regulate basic constraints for the development of tissue types, function models and tissue models. Minimum dimensions of O-zones, according to building height, are indicated in Fig. TR 8.

Dimensions of O-zones in relation to circulation elements are shown in Fig. TR 11. Requirements for parking space and sizes of public green and playground areas refer to the City Planning Code of San Francisco.⁶ In the code, areas for public green and playgrounds are regulated, not for individual blocks, but for regions. The study, "Recreation and Open Space Programs"⁷ recommends minimum areas for public spaces on the block scale and

⁶San Francisco Municipal Code, Part II, Chapter II

⁷"Recreation and Open Space Programs: Recommendations for implementing the recreation and open space element of the comprehensive plan of San Francisco, presented by the Department of City Planning, July 1973."

FIG.
TR 11

PROPOSED TISSUE MODEL
CIRCULATION ELEMENTS

DIMENSIONS OF MAIN STREETS WITH PARKING FUNCTION

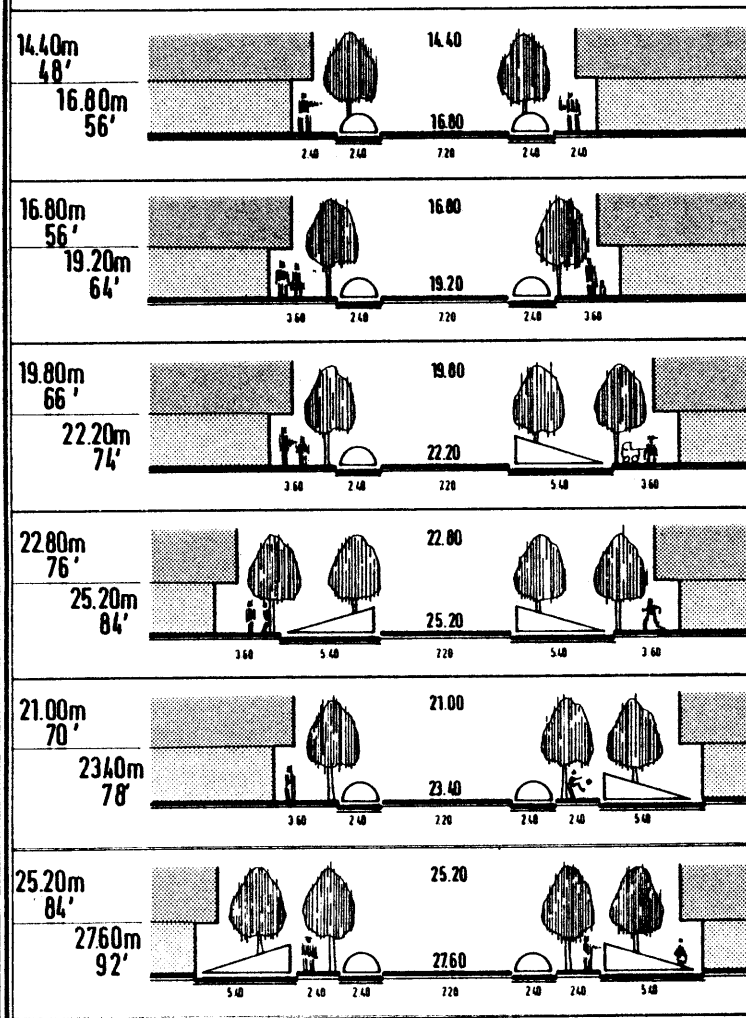

DIMENSIONS OF ALLEYS WITHOUT / WITH PARKING FUNCTION

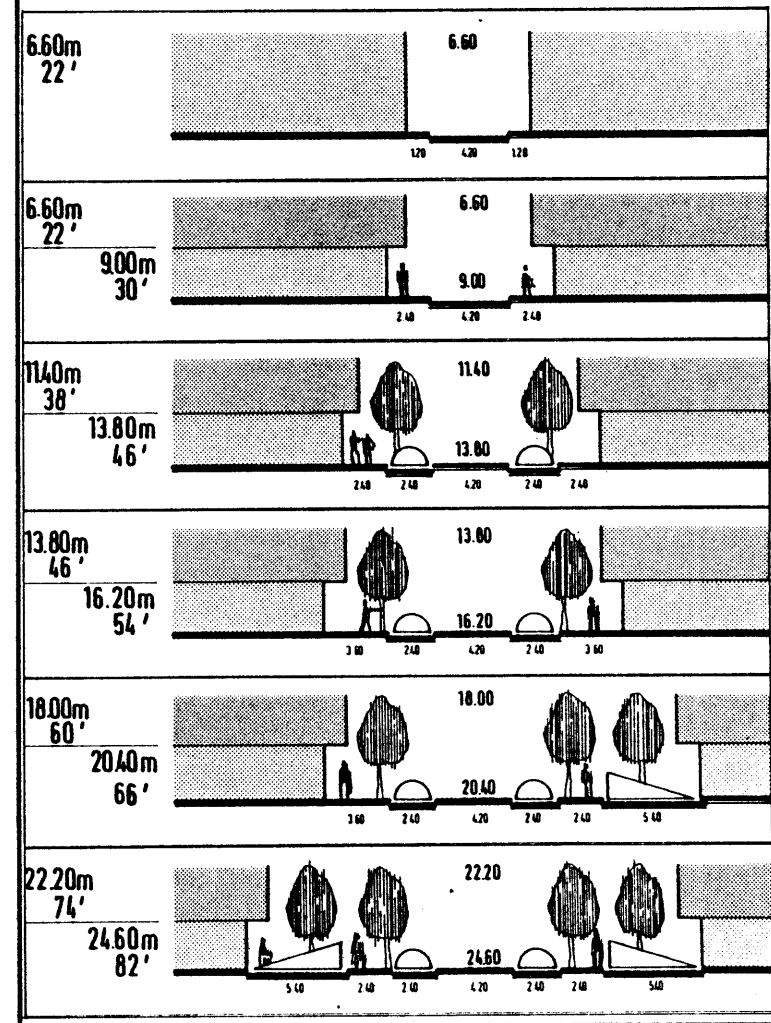

recommends concentration of landscaping in the block center. (Fig. TR 12) This study recommends at least two separate spaces per block for public green or playgrounds, a recommendation which has been successfully applied in various new projects developed on the block scale.

The San Francisco Department of City Planning recommends landscaping of the inner block area. Location of public areas in this part of the block will provide the required public green for each separate block, as well as the required small block-related playgrounds.

The size of these elements may vary according to the building types in a block (apartments or townhouses). Blocks consisting mainly of apartment buildings will require more open public space than blocks dominated by townhouses with large private gardens. A minimum area of 5000 square feet (450 m²) is recommended for each of these elements.

3.412 RULES REGULATING THE CORRELATION OF BUILT ELEMENTS (SUPPORT SECTORS)

Rules for the new tissue model must be expanded to more detailed determinations regulating agreements on the support level. A support is "that

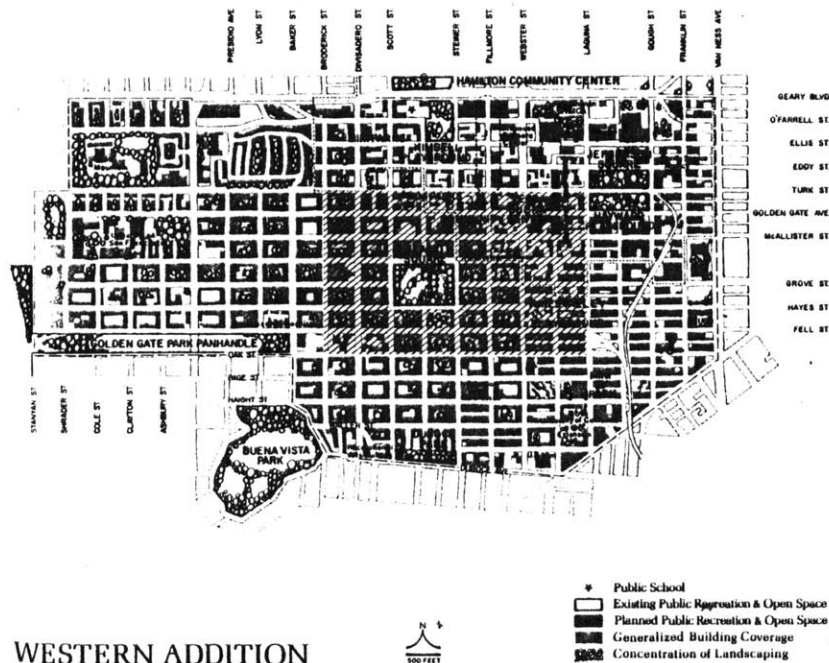

Fig. TR 12

part of an habitable structure over which the resident has no individual control."⁸

These rules relate to the hard systems (thematic lot subdivision patterns and uniformity of construction) as well as to the soft systems which reflect the variety of the streetscapes, based on such characteristics as individual ornamentation and color changes.⁹

The existing situation presents an accumulation of separate buildings, which have common patterns of location, construction, and floor plan arrangements, and exhibit similarities in the functions of groups of built elements.

The support level of existing block tissue is here defined as the characteristics of the individual dwellings and their mutual relationships. Although the elements and characteristics of a single dwelling are important criteria for the morphology of the streetscape, analysis of their correlations is of more importance.

The following set of rules will regulate elements of the tissue model, assimilating the relationships between existing buildings. In addition to these regulations, it will be necessary to develop regulations for the new tissue model which are based on the characteristics and features of individual building types.

⁸N.J. Habraken et. al., Variations: The systematic design of supports. (Cambridge, Mass.: MIT Laboratory of Architecture and Planning. 1976) p. 106

⁹N.J. Habraken, Three R's for Housing. (Amsterdam: Scheltema and Holkema. 1966)

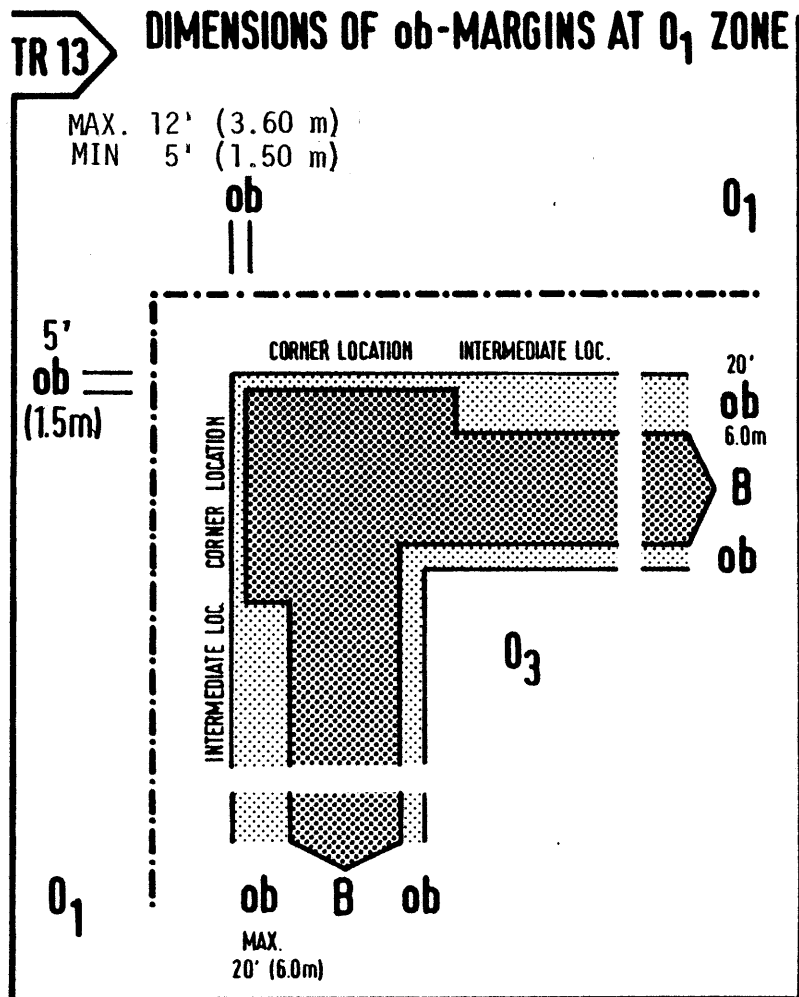

Individual dwellings are positioned on sites in different ways, according to the relation of lot size and building type. Buildings have different positions in relation to front and side lot lines.

Modulation of street elevation parallel to the street is formed by the position of buildings in relation to front lot lines. Although an analysis of existing block tissue shows an average depth and location of the B-zone, variations in set-backs for individual buildings create a varying position of the B-zone along some streets.

Analysis of the existing situation shows that corners are emphasized by higher apartment buildings; the tissue is characterized by corner and intermediate locations. The proposed tissue model assimilates this and defines O-zones for both locations. A corner location of a built zone is defined by a position along two major streets. Each side of the built zone has a maximum depth of 90' (30 m) from the street axis.

Rule 8: Depths of ob-margins for corner locations range between 5' (1.5 m) and 12' (3.6 m). Depths of ob-margins for intermediate locations vary between 5' (1.5 m) and 20' (6 m). (Fig. TR 13)

TR 17 DIMENSION OF PATH IN B-ZONE

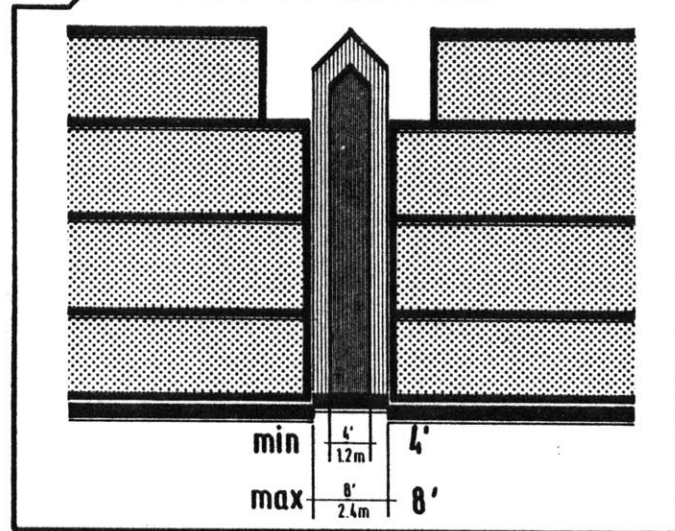

TR 18 MINIMUM VERTICAL CLEARANCE OF PATH

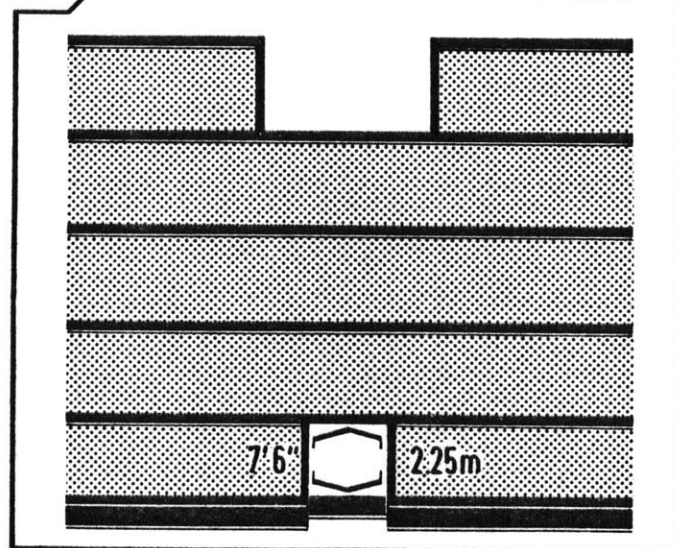

B-zones. Application of continuous B-zones will be an exception, in this context non-thematic.

Modulation of street elevation perpendicular to the street. Empty lots and side yards in the existing streetscape create openings in the B-zone. These situations, which occur often, are thematic elements of the Victorian streetscape. To assimilate this criteria into the proposed tissue model, a zoning system perpendicular to the B-zone is necessary. O-zones perpendicular to the B-zone should be narrow to preserve the character of the closed block.

Rule 10: There may be openings (O-zones) in the B-zone, according to the elements of the existing streetscape with the characteristics of a function model.

A) Alleys with vehicular circulation in only one direction may have a maximum width of 20' (12' for the O-zone, 2 x 4' for the ob-margins). This is a restatement of Rule 3.

B) Paths through the B-zone may have a minimum width of 4' (1.2 m) and a maximum width of 8' (2.4 m). A superstructure may be built over these paths, if a mini-

imum vertical clearance of 7'6" (2.25 m) is guaranteed. (Figs. TR 17 and TR 18)
 C) Perpendicular 0-zones with the functions of public green, playgrounds, or parking lots should be exceptions and should only occur if required by specific circulation patterns or reasonable constraints of the adjacent environment. (Fig. TR 19)

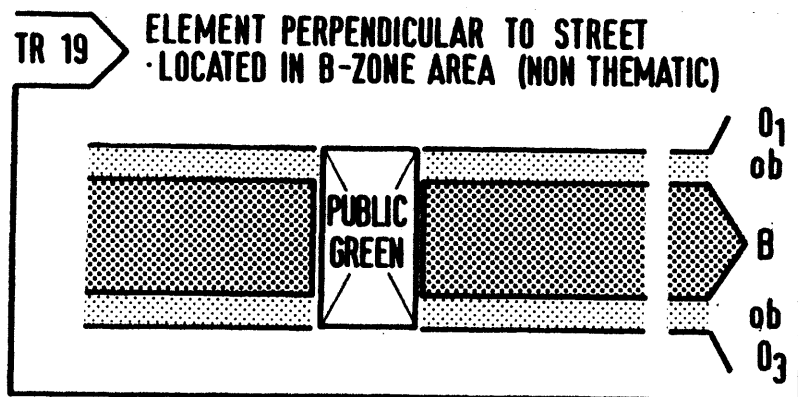

Recess elements on one or both sides of a building are characteristic of the San Francisco streetscape. These elements are between 3' (0.9 m) and 6' (1.80 m) wide. Their depth may vary from 12' (3.6 m) to 21' (6.3 m), according to the specific floor plan of the existing building.¹⁰ A recess element may be defined as an ob-margin perpendicular to the B-zone.

Rule 11: If the adjacent morphology includes recesses as one of its important elements, the new tissue model must include perpendicular ob-margins of 3' (0.9 m) to 6' (1.8 m) in width at least every 50' (15 m).

¹⁰For further discussion, see the section on typology of buildings in the report "Urban Form and Change."
 142

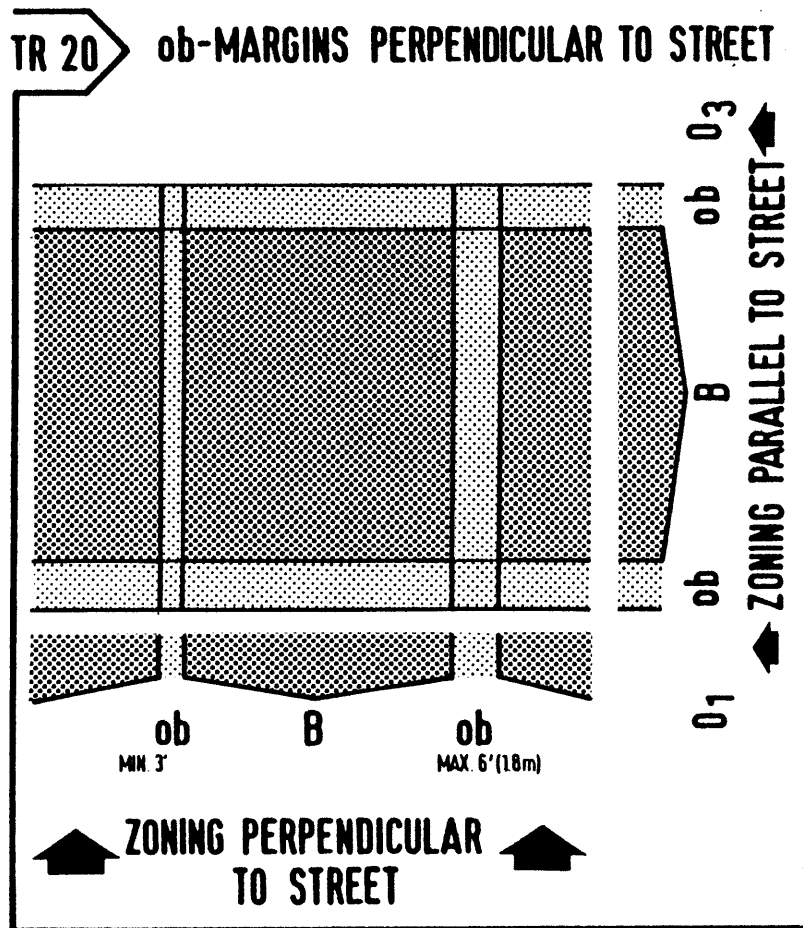

(1.8 m) in width at least every 50' (15 m). The depth of the ob-margin for recess assimilation, in relation to the position of the front facade, must be at least 12' (3.6 m). (Fig. TR 20)

Rules 1 to 10 regulate determinations for the arrangement of the B-zone in relation to the main floor area. Lot subdivision, topography, similar construction methods and, very often, the repetition of a building type, create relations of patterns of built elements on the roof and base levels as well as on the main floor levels.

In the existing situation, roof lines of each building step with the slope. Regulations for the roof must be made parallel to the street as well as perpendicular.

Modulation of roof elevation (set-back of the upper floor). The study "Change Without Loss"¹¹ proposes a set-back for the upper floor of at least 6' (1.8 m) every 50' (15 m) to break the cornice line of buildings less than 40' high and to protect the varied character of residential districts.

¹¹ College of Environmental Design, University of California at Berkeley, "Change Without Loss." 1977. p.15

Analysis of the situation around Alamo Square shows that thirty-four per cent of the existing buildings have three floors. Most of these are Victorian buildings with an average floor height of 11' (3.30 m). Today, the standard floor height is between 8' (2.4 m) and 9' (2.7 m). This means that a new building is not as high as a Victorian building with the same number of floors. A maximum difference of 3' (0.9 m) per floor, based on an 8' floor height for new buildings, will produce a 9' difference in height between a modern and a Victorian three-story house. This is equal to the height of one floor, at current standards. Therefore, if current construction standards must be used in the Victorian street-streetscape, the cornice level will differ by the height of one floor.

To eliminate this height difference, a residential use for the roof story is proposed. The roof area may be used as an extension of the upper floor or for a separate apartment or studio unit. This proposal is based on an average modern floor height of 9' (2.7 m), with a base height of 7'6" (2.25 m).

The position of built elements in the roof area must be regulated both parallel and perpendicular to the street. This determination, based on a 9' floor height, will increase the building height to 43'6" (13.05 m) for a three-story building, 3'6" higher than the maximum height, 40' (12 m), regulated for dwellings in the City Planning Code.¹²

¹²San Francisco Municipal Code, Section 261.

Height must be measured within a distance of the dimensions given in Rule 9, averaging minimum and maximum heights from the ground to the cornice line. (Fig. TR 21)

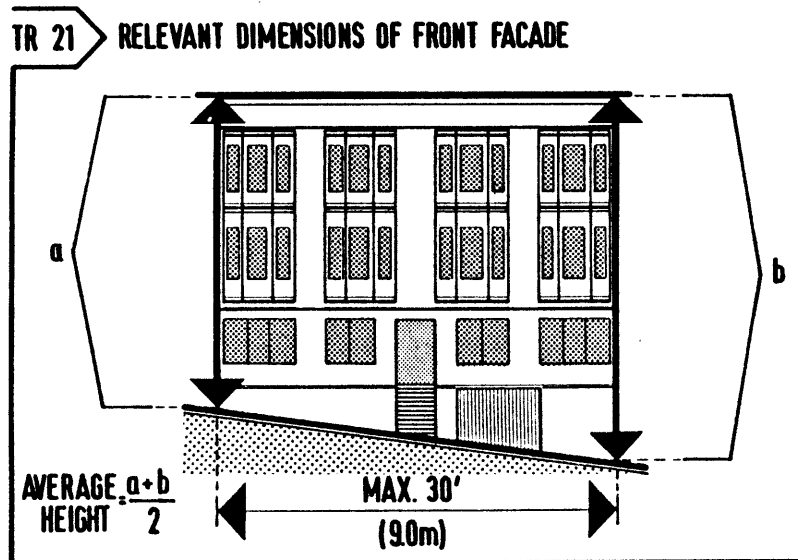

Rule 12: The roof story may be used for residential space. The roof facade must be set back at least 8' (2.4 m) in the front and back. In corner locations, the roof story must be set back on both sides which are oriented to major streets. One side of this set-back, of a width of 8' (2.4 m), may be used for circulation space (staircase). Perpendicular to the street, a clearance with a minimum width of 4' (1.2 m) must interrupt the continuity at least every 26' (7.8 m). (Fig. TR 22) If the depth is less than 24' (7.2 m), the set-back to the yard must be at least 4' (1.2 m).

This rule assimilates the morphology of the existing situation (different roof shapes, ornamentation elements, corner towers, gables, etc.) and is an instrument to increase density.

TR 22

ROOF STORY DIMENSIONS OF MINIMUM SET BACKS

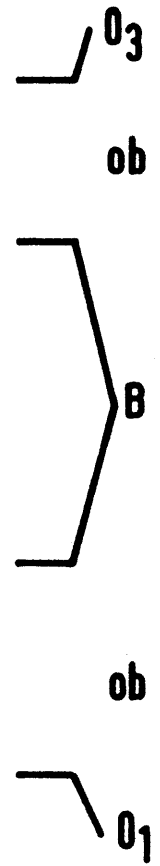
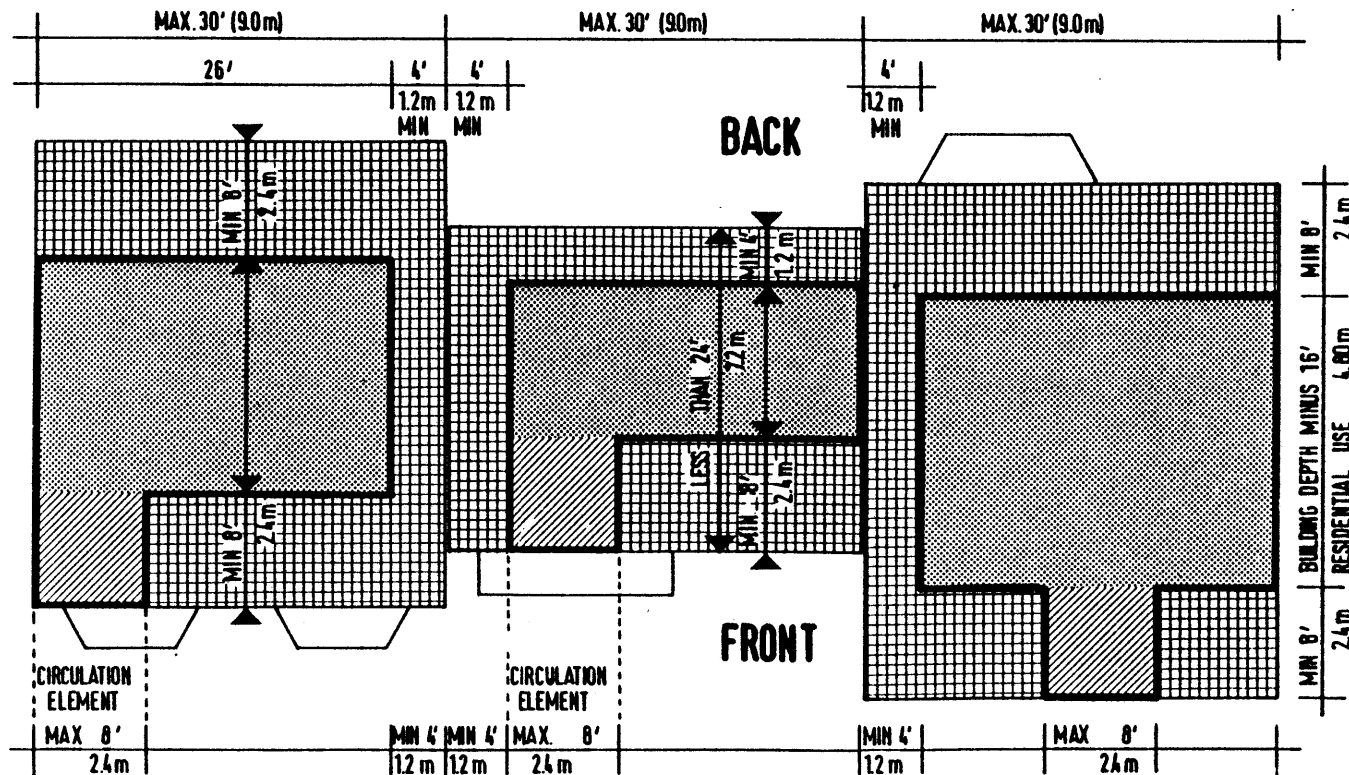

In the existing streetscape, roofs step with the slope. An important element of the streetscape, this will be assimilated into the rules of the new tissue model.

Rule 13: Roof lines must follow slopes. For a roof story, the dimension of a continuous roof line is limited to a width of 26' (7.8 m), and for a cornice over a main floor, the roof line is limited to 30' (9 m). (Fig. TR 23)

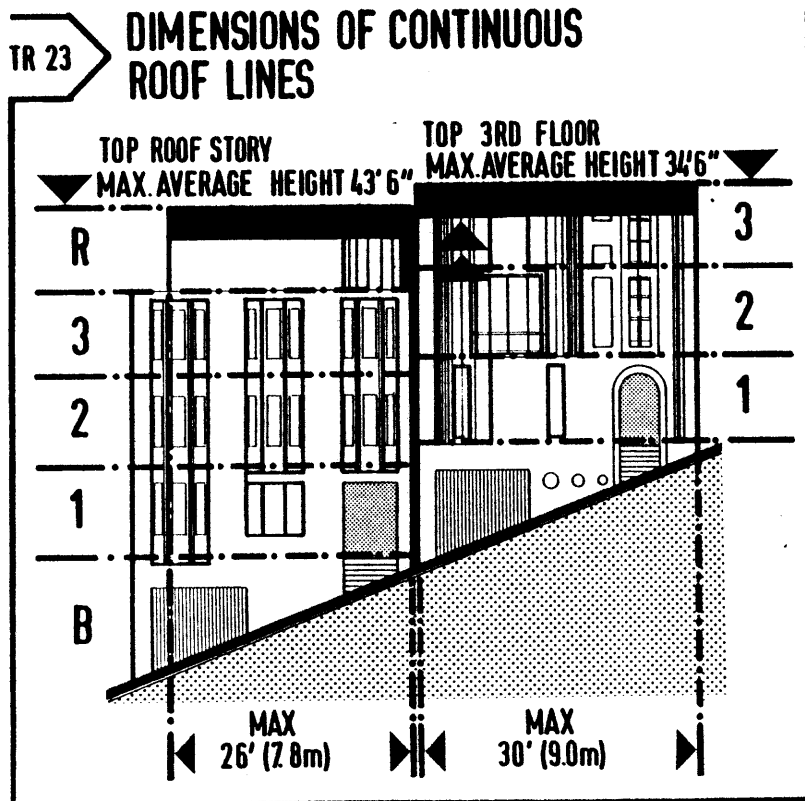

The height of the roof line for the front and back is measured according to Rule 9, averaging minimum and maximum distances between the ground and the roof line. This rule is relevant to the front and back of the B-zone, assuring a stepping with the slope perpendicular to the B-zone.

Dimensions for B-zones with different numbers of main floors are as follows:

Number of Main Floors	Max. Height for Cornice over Top Main Floor	Max. Height for Cornice over Roof Story
2	25'6" (7.65 m)	34'6" (10.35 m)
3	34'6" (10.35 m)	43'6" (13.05 m)
4 (corner only)	43'6" (13.05 m)	52'6" (15.75 m)

If the slope is steeper than ten degrees, an additional floor may be added to the general height for stepping with a slope. (Fig. TR 24)

Rule 14: To emphasize the continuity of a roof-scape, attached roofs with gables should not change direction of the gable which must face the street. (Fig. TR 25)

The correlation of roof elements has an impact on the visual quality of the morphology in the upper section of the streetscape and, by its height, the roof influences light conditions in the street and for opposite built elements.

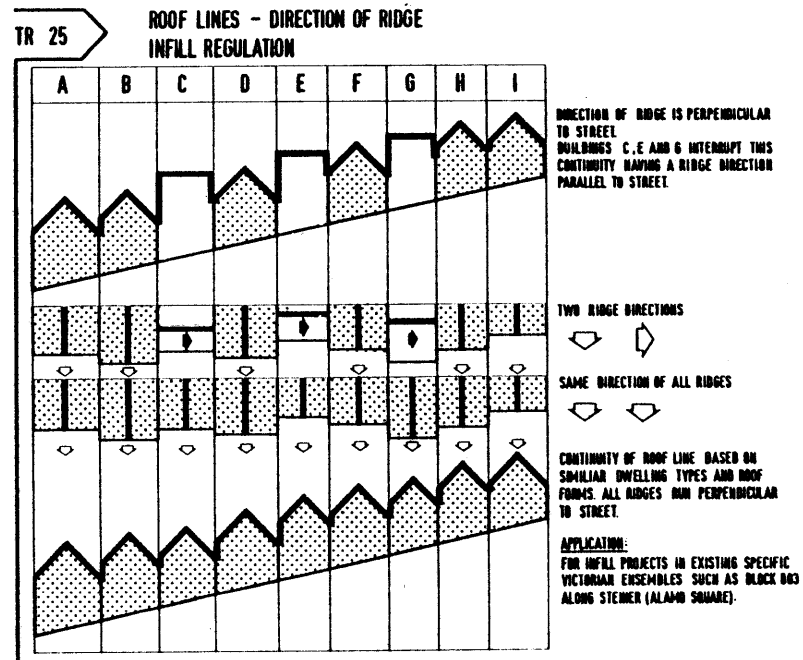
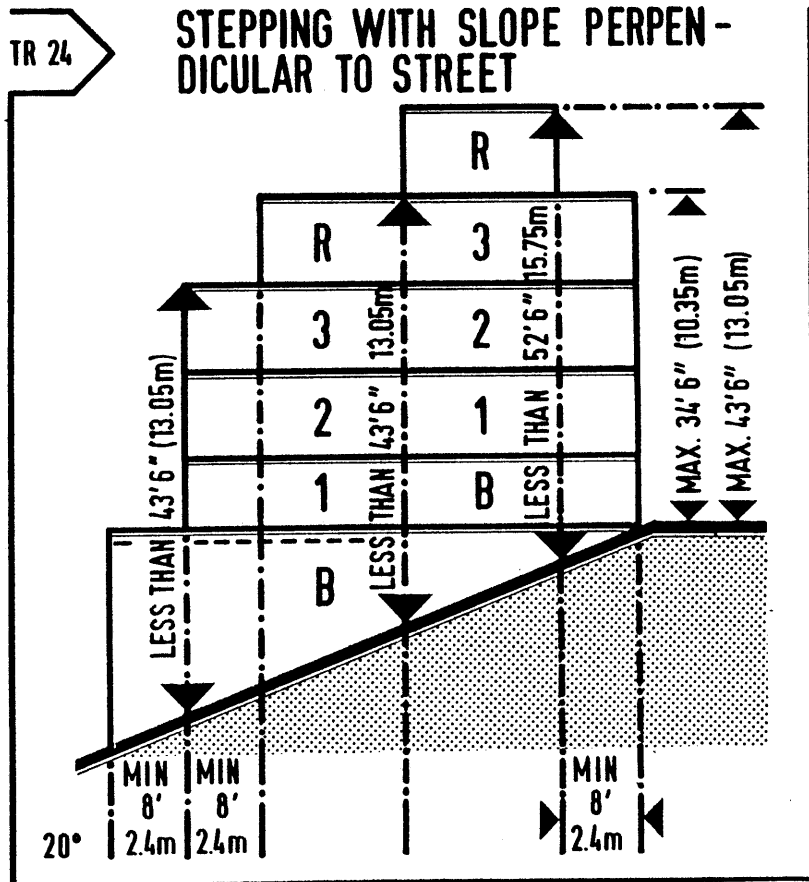

TR 26

BASE - REGULATIONS OF ob - MARGIN - FRONT

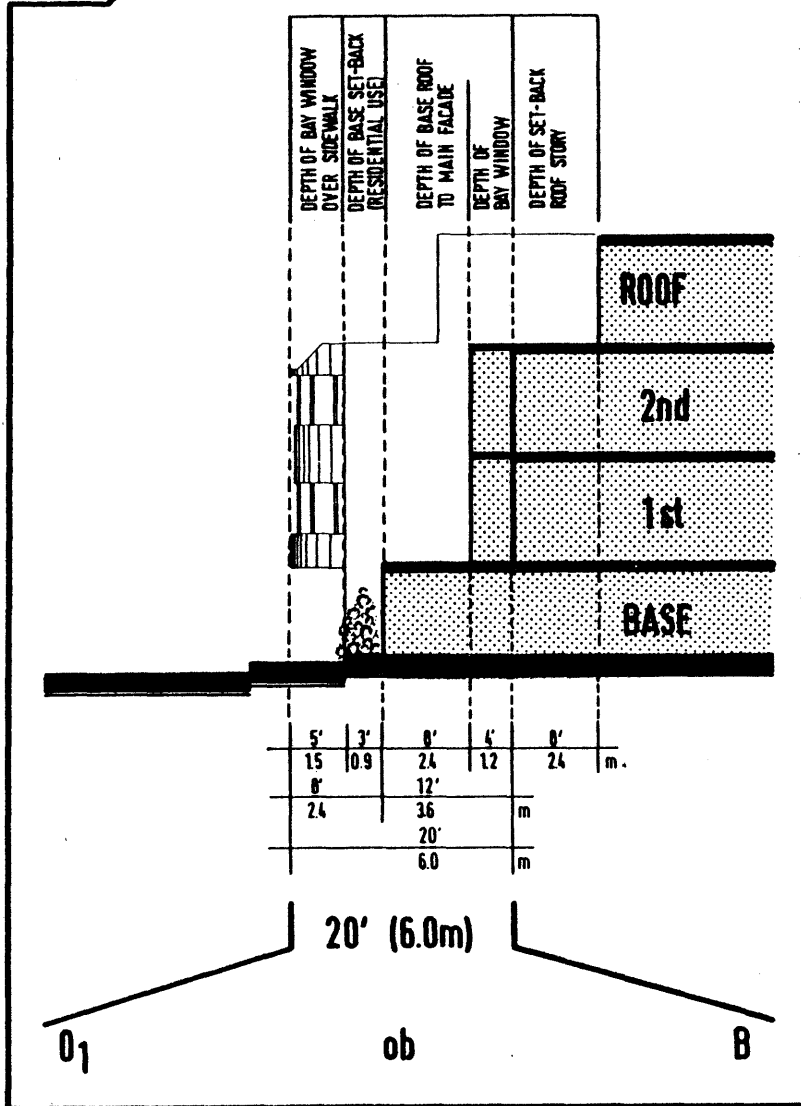

3.413

RULES REGULATING LOCATION AND DIMENSION IN SEPARATE SECTIONS (DETACHABLE UNITS)

Regulations for the base. The base zone is perceived directly from the street and sidewalk. Its elements and functions characterize the visual quality as well as the criteria of security and comfort for pedestrian circulation (by open garage doors, ramps at curb cuts, etc.).

The base can be used for both commercial and residential purposes. A combination of parking and residential use is possible, if regulations of the San Francisco Municipal Code regarding light, ventilation, and security are fulfilled.

Rule 15: The width of a base may extend continuously over the whole B-zone, within the limitations of zoning Rules 9 and 10.

Rule 16: The depth of the base must fulfill regulations for the depth of the B-zone. The base may extend further in the front and back.

A) Base extension to the street. The base may not extend onto the sidewalk. If the B-zone is set back, the base may extend into the ob-margin to the side-

BASE · FRONT LOCATION

TR 27

BASE · MAXIMUM WIDTH · SIDE CLEARANCES RESIDENTIAL USE

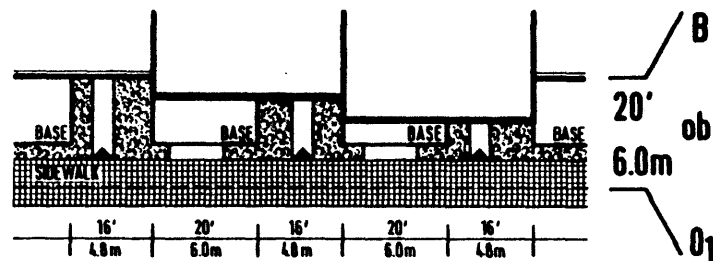

TR 28

BASE · MAXIMUM WIDTH · SIDE CLEARANCES COMMERCIAL USE

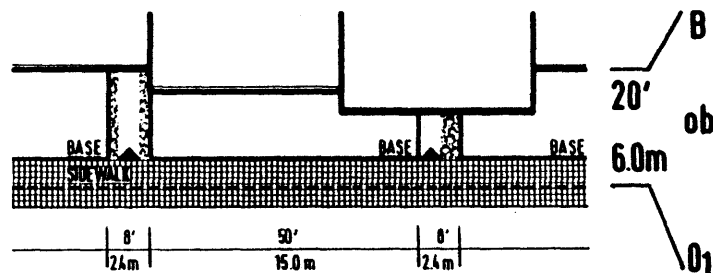

walk. If the base has a residential use (parking or living), the base must be set back at least 3' (0.9 m) from the sidewalk to provide a minimum of space for landscaping (Fig. TR 26). For each 20' (6.0 m) of extending base, an opening at least 16' (4.8 m) wide for B-zone access must be guaranteed (Fig. TR 27). For commercial use, the base may extend onto the sidewalk, leaving an opening of 8' (2.4 m) or more at least every 50' (15 m). (Fig. TR 28)

B) Base extension to the back. The base may extend in the back approximately 8' (2.4 m) from the back facade. It must always be placed with the ob-margin, touching the O_3 -zone (Fig. TR 29). The roof of the base, in front and in back, must remain uncovered by permanent constructions, but may be used for residential purposes, as terrace space.

C) Height of the base. The height of the base is measured from the sidewalk level, averaging minimum and maximum heights within a width of 20' (6 m) for residential

use and approximately 30' (9 m) for commercial use. The height must relate to Rule 9 as well. Maximum height for the base is 7'6" (2.25 m).

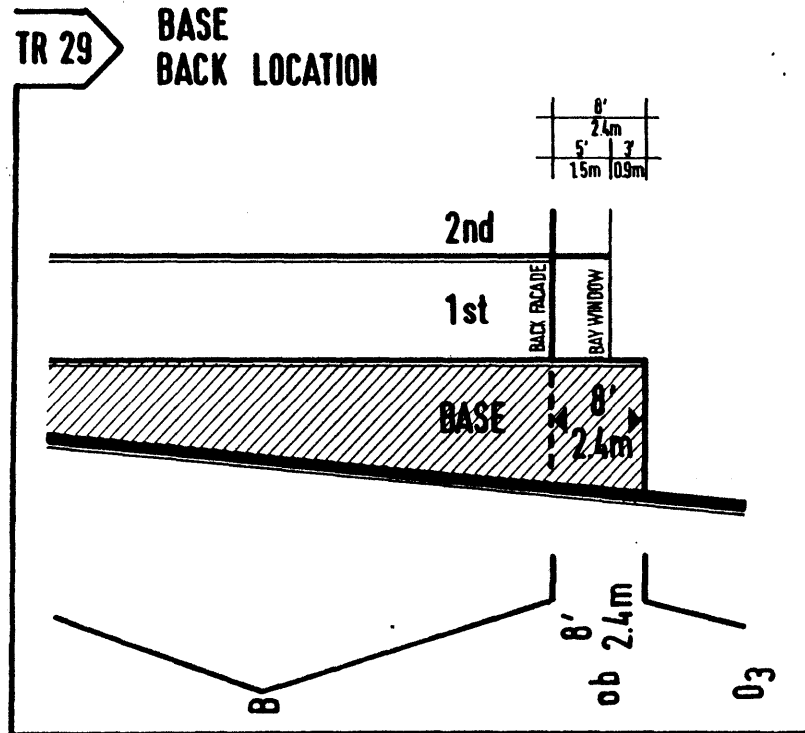

Beside the dimensions and functions of the base, elements of the base such as doors, stairs, shop-windows, and landscaping are important for eye-level perception.

Curb cuts are a very important element in relation to the width of both a whole building and garage doors. The Berkeley study recommends a reduction in the number of existing curb cuts which now dominate the base area and have a negative influence on the visual quality of that area, and proposes legislation of a limit in the number of curb cuts:

Lots of 25 ft. or less in width may not have more than 10 ft. of curb cut per lot. Where the property line at the street has a slope of 5% or less; curb cuts on adjacent lots shall be arranged so that a 20' on-street parking place is provided between them. Lots wider than 25' may not have more than one 10' wide curb cut per 3000 sq. ft. of parking area, except where garages must provide for more than 50 cars.¹³

¹³"Change Without Loss." p. 28

PARKING ALTERNATIVES

1 PARKING UNDER BUILDINGS ACCESS FROM MAIN STREET OR ALLEY

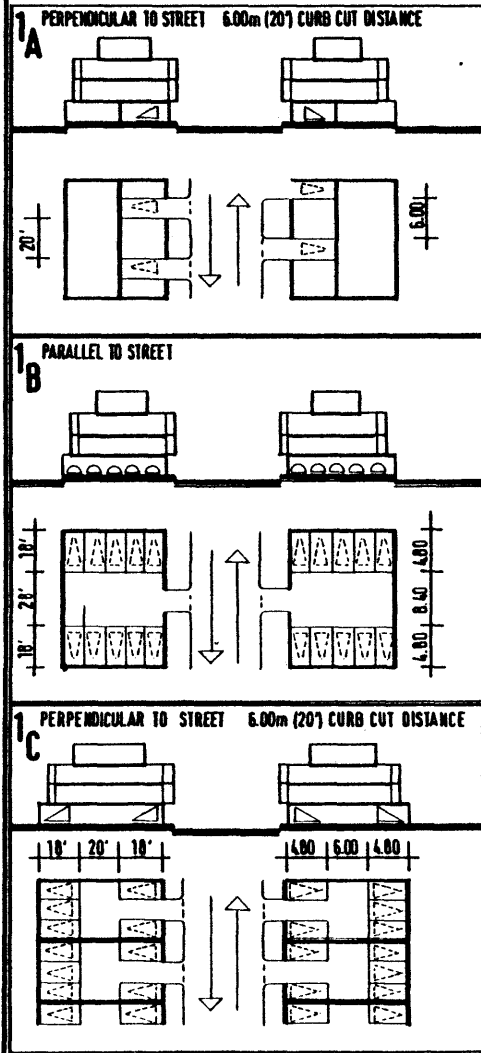

2 PARKING IN COURTYARDS MINIMUM DIMENSIONS

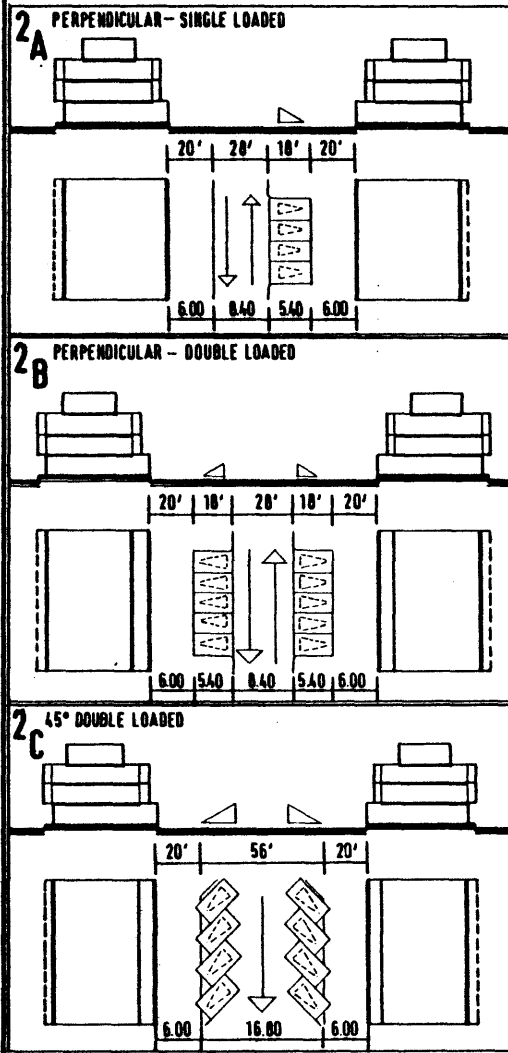

3 PARKING UNDER BUILDINGS ACCESS FROM STREET AND COURTYARD

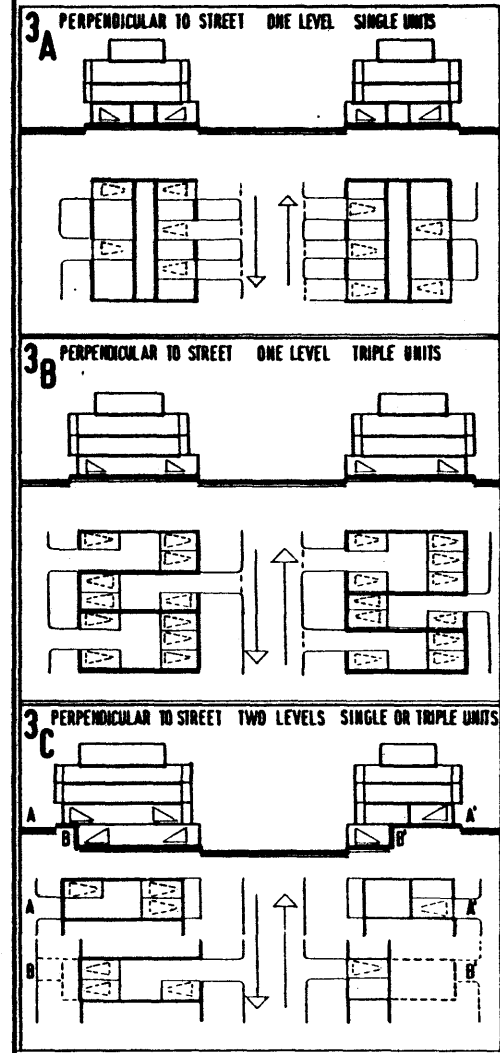

Fig. TR 30

Rule 17: The proposed tissue model assimilates this determination into its rules and makes the recommendations presented above. In the tissue model, distances of curb cuts are only dimensionally related. Additional alternatives for positioning curb cuts and street parking places are shown in Fig. TR 30.

Rule 18: Entrances to buildings shall not be aggregated; separate entrances to townhouses are recommended.

The tissue model must consider this determination in the development of access patterns by the design of support structures.

Bay windows and balconies. In an analysis of the existing tissue, the importance of the bay window structure for the street level elevation becomes obvious. In addition to their function of providing extra light and view for residents, they are the dominant morphological element in the streetscape. Their different sizes, proportions, styles and ornaments give most streets a unique character. It is absolutely necessary to include regulations for the application of bay windows in the rules of the new tissue model.

Rule 19: On the main floor area each room may have a bay window or balcony in the front or back facade. The bay window must remain within the ob-margin. If the front facade is located at the sidewalk, it is necessary to provide a

ARTICLE 5
USE OF STREET AREAS

Sec. 501. Projections Over Streets and Alleys.

SEC. 501. Projections Over Streets and Alleys.

(a) **General.** Projections from any building or structure may extend over a street or alley only where, and to the extent, specified in this Section. Every portion of such projections over a street or alley shall provide a minimum of 10 feet of vertical clearance from the sidewalk or other surface above which it is situated, unless the contrary is stated below. The permit under which such a projection is erected over public property shall not be construed to create any perpetual right but is a revocable license. In cases in which a set-back line has been established under Article 4 of this Code, the limitations of this Section shall be applicable to projections within the required set-back area, and in such cases the term "property line along the street or alley" as used in this Section shall be read as "set-back line", and the term "street or alley" shall be read as "set-back area" except in subsection (b) below.

(b) **Lot coverage.** Any projection over a street or alley, when permitted by this Section, shall be exempt from the calculation of lot coverage for purposes of Section 125 of this Code. Any projection beyond a required set-back line, when permitted by this Section and Section 402, shall be exempt from the calculation of lot coverage for purposes of Section 125 of this Code.

(c) **Bay windows and balconies.** Bay windows and balconies, and similar features that increase either the floor area of the building or the volume of space enclosed by the building above grade, shall be limited as follows:

1. Projection beyond the property line along the street or alley shall be limited to 2 feet where the sidewalk width is 9 feet or less, and 3 feet where the sidewalk width is more than 9 feet; provided, however, that such projection shall in no case be closer than 8 feet to the center line of any alley.
2. The glass areas of each bay window, and the open areas of each balcony, shall be not less than 50 per cent of the sum of the areas of the vertical surfaces of such bay window or balcony outside the property line along the street or alley. At least one-third of such required glass area of such bay window, and open area of such balcony, shall be on one or more vertical surfaces situated at an angle of not less than 30 degrees to the property line along the street or alley. In addition, at least one-third of such required glass area or open area shall be on the vertical surface parallel to, or most nearly parallel to, the property line of each street or alley over which the bay window or balcony projects.
3. The maximum width of each bay window or balcony shall be 15 feet at the property line along the street or alley, and shall be reduced in proportion to the distance from such property line by means of 45 degree angles drawn inward from the ends of such 15-foot dimension, reaching a maximum of 9 feet along a line parallel to and at a distance of 3 feet from such property line.
4. The minimum horizontal separation between bay windows, between balconies, and between bay windows and balconies, shall be 2 feet at the property line along the street or alley, and shall be increased in proportion to the distance from such property line by means of 135 degree angles drawn outward from the ends of such 2-foot dimension, reaching a minimum of 8 feet along a line parallel to and at a distance of 3 feet from such property line.
5. Each bay window or balcony shall also be horizontally separated from interior lot lines by not less than one foot at the property line along the street or alley, with such separation increased in proportion to the distance from such property line by means of a 135 degree angle drawn outward from such one-foot dimension, reaching a minimum of 4 feet along a line parallel to and at a distance of 3 feet from such property line.

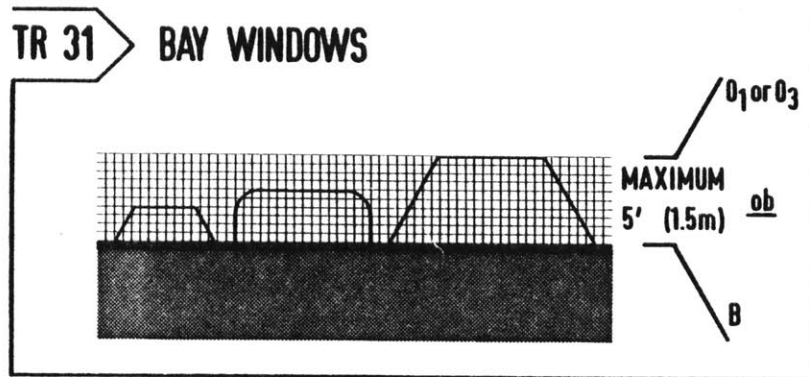

vertical clearance of 7'6" (2.25 m) between the sidewalk level and the bay window. The same clearance must be provided for balconies. If the front facade is set back from the sidewalk more than the depth of the bay window, a vertical clearance from the ground is not necessary. (Fig. TR 31)

The San Francisco City Planning Code has recognized the importance of bay windows and regulated details of bay windows in Article 5, Section 501. (Fig. TR 32) If bay windows have a depth of more than two feet, they must fulfill certain construction requirements regarding fire hazards and preventions. The proposed tissue model expands this depth to five feet and assimilates other rules from the planning code.

These nineteen proposed rules are only a framework. Additional regulations for streetscapes and landscaping of courtyards, as well as norms for extreme topographical situations can complete the tissue model.

3.414

HIERARCHY OF TISSUE MODEL RULES

I. General Rules for the Development of Tissue Types and Function Models (Tissue Level)

Rule 1: Street axis

Rule 2: Dimensions of major streets

Rule 3: Location and dimensions of alleys

Rule 4: Location and dimensions of paths

Rule 5: Courtyards

Rule 6: B-zones, location and dimensions

Rule 7: Ob-margins, location and dimensions

II. Rules Which Regulate the Correlation of Built Elements (Support Level)

Rule 8: Corner location and intermediate location

Rule 9: Variable position of the B-zone

Rule 10: Interruptions in the continuity of B-zones by O-zones (zoning system perpendicular to the street)

Rule 11: Interruptions in the continuity of B-zones by ob-margins (zoning system perpendicular to the street)

III. Rules Which Regulate the Morphology of Individual Units and Their Correlation (Sector Level)

Rule 12: Roof story, position and dimensions

Rule 13: Stepping with the slope, maximum dimensions for continuous cornices

Rule 14: Correlation of roof slopes

Rule 15: Base – width, location and dimensions

Rule 16: Base – depth and height, location and dimensions

Rule 17: Base – curb cuts

Rule 18: Base – entrances

Rule 19: Bay windows, balconies

3.42

CALCULATING DENSITY WITH THE TISSUE MODEL

Various functions, such as vehicular and pedestrian circulation, public green or playgrounds, parking, and private gardens, have been defined for the function models. From each function model it is possible to derive tissue models which may vary in the height of buildings and dimensions of open space.

Rules for the development of tissue models more or less regulate the formal aspects of a block tissue. Proposed dimensions of open spaces and access streets, including alleys, and regulations of maximum building height permit a formal tissue layout, but do not provide detailed information about the capacity or number of units per block. Although this study emphasizes the formal aspects of an arrangement of built elements, the possibility of quantifying different tissue models must be included. For the pragmatic application of the tissue method, it is absolutely necessary to compare different tissue models with each other. Therefore, the capacity of the support (e.g., dimensions of dwellings and number of units and surfaces) must be specified.

The study Deciding on Density¹⁴ offers a very systematic method, using the relation between plot proportion and dwelling, to show that deep, narrow plots produce higher density than shallow, wide plots. Each dwelling type which is put into a tissue

¹⁴Deciding on Density, p. 44

is given three sets of dimensions. Calculation is based on dwelling types with a narrow and deep plot, a shallow and wide plot, or an average-sized plot. Dwellings with different numbers of floors are used. The average surface area of the dwelling is the same, ninety square meters, for all dwellings; dwellings with shared staircases have a total surface area of one hundred square meters. This method could be applied to the density analysis of this study, if similar dwelling types were used.

Analysis of the Alamo Square area indicates a large variety of building types and lot/building relationships. New developments in this area will include mass housing as well as privately initiated projects. Considering the importance of the formal aspects of the morphology, such as set-backs, recesses, and side gardens, the basic rules of SAR 65 and SAR 73 provide very helpful tools to organize and evaluate tissue models for this area.

The basis of the tissue model is the support structure, a structure which is designed for a specific place, after important criteria have been decided upon by the community. The support is complete with detachable units, as decided by the individual resident.

The support could be a physical structure in which all detachable units fit together to create dwellings of different sizes and shapes, according to their functions. Examples of this kind of support, the Bijlmer support system, the twin support system, the low rise support system, and the longitudinal support system, are

presented in Variations.¹⁵ They are defined as "non-specific" support systems, implying that they do not relate to a specific situation. They are neutral, but offer enough flexibility to be adaptable to a specific environment. These systems have in common that they are physical, based on present construction methods.

Using such a system for the tissue models around Alamo Square would mean building physical structures on a larger scale than a single dwelling. Building would be controlled by the community or a participatory planning process to provide space for infill of detachable units. This method could be applied very well to mass housing projects or condominiums.

Private homes and condominiums have been built recently around Alamo Square, in Blocks 773, 780, 781, 796, and 820, for example. Very high plot prices in this urban area impede the purchase of land for public housing. Most plots are being developed singly, by private individuals or companies. For such a situation, it would be difficult to combine different interests and budgets at one time to create a physical support structure.

Considering these circumstances, this study proposes the application of a "soft," non-physical support, organizing location and minimum and maximum dimensions of residential functions by regulating zone distribution. With this regulation process, it would be possible to control single private developments as well as provide guidelines for community support structures.

¹⁵Habraken, Variations. pp. 120-170

To specify the built zones of tissue models of the area around Alamo Square, two different kinds of "supports" will be applied:

A) The inner parts of the blocks will require community initiative to be developed for residential use. Buildings inside a block will not be perceived in the same morphological context as buildings along major streets. The location of a physical support system, which could be used for public housing or condominiums, is proposed for built elements in the inner block (Support System A).

B) For intermediate locations along main streets and cross streets, this study proposes built elements which are based on the "soft support," a regulation of zone distribution (Support System B).

Corner locations along major streets will be occupied by apartment buildings which are based on the formal rules of the tissue model.

3.421

THE PHYSICAL SUPPORT – SUPPORT SYSTEM A

Built elements in the inner block area have no direct formal relation to the morphology of the existing Victorian streetscape. Therefore, new tissue rules which regulate such elements as recesses and set-backs are not as binding for these built elements as they are for structures along major streets. Theoretically,

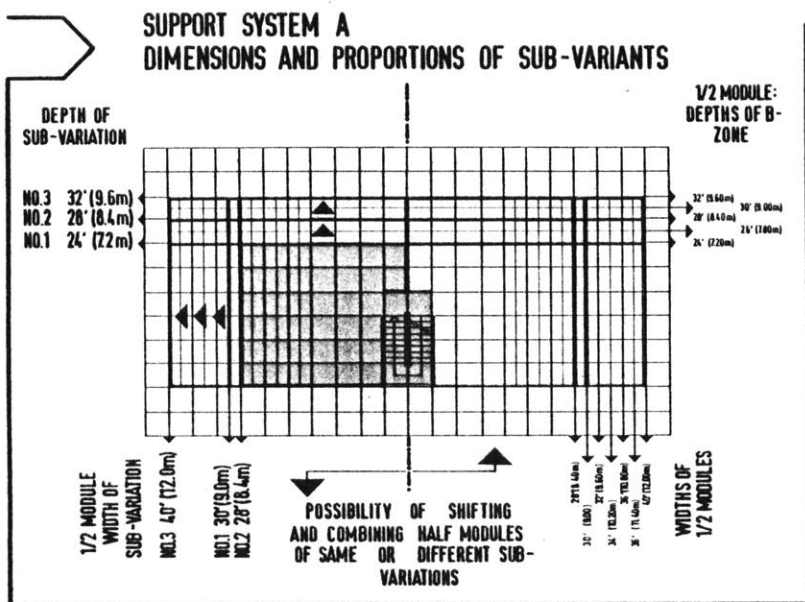

Fig. 106

if general regulations for position and dimensions of B-zones are fulfilled, inside built elements could assume any shape or location.

Support System A (Fig. 106) is a low rise system based on principles of housing construction developed by Stichting Bowcentrum and Stichting Ratiobouw from their research and revised in 1969.¹⁶ The support for this system can provide apartments for public housing or condominiums. Units have a common staircase; separate access to the back yard is possible.

For location inside a block, the support provides two main floors, a base for parking and storage, and a roof story which is set back from the front facade and used as an extension of second floor residential space for separate units. (Figs. 106, 107)

To enable evaluation of the capacity of the tissue model using this support system, different sub-variations were examined.

¹⁶Habraken, Variations. p. 146

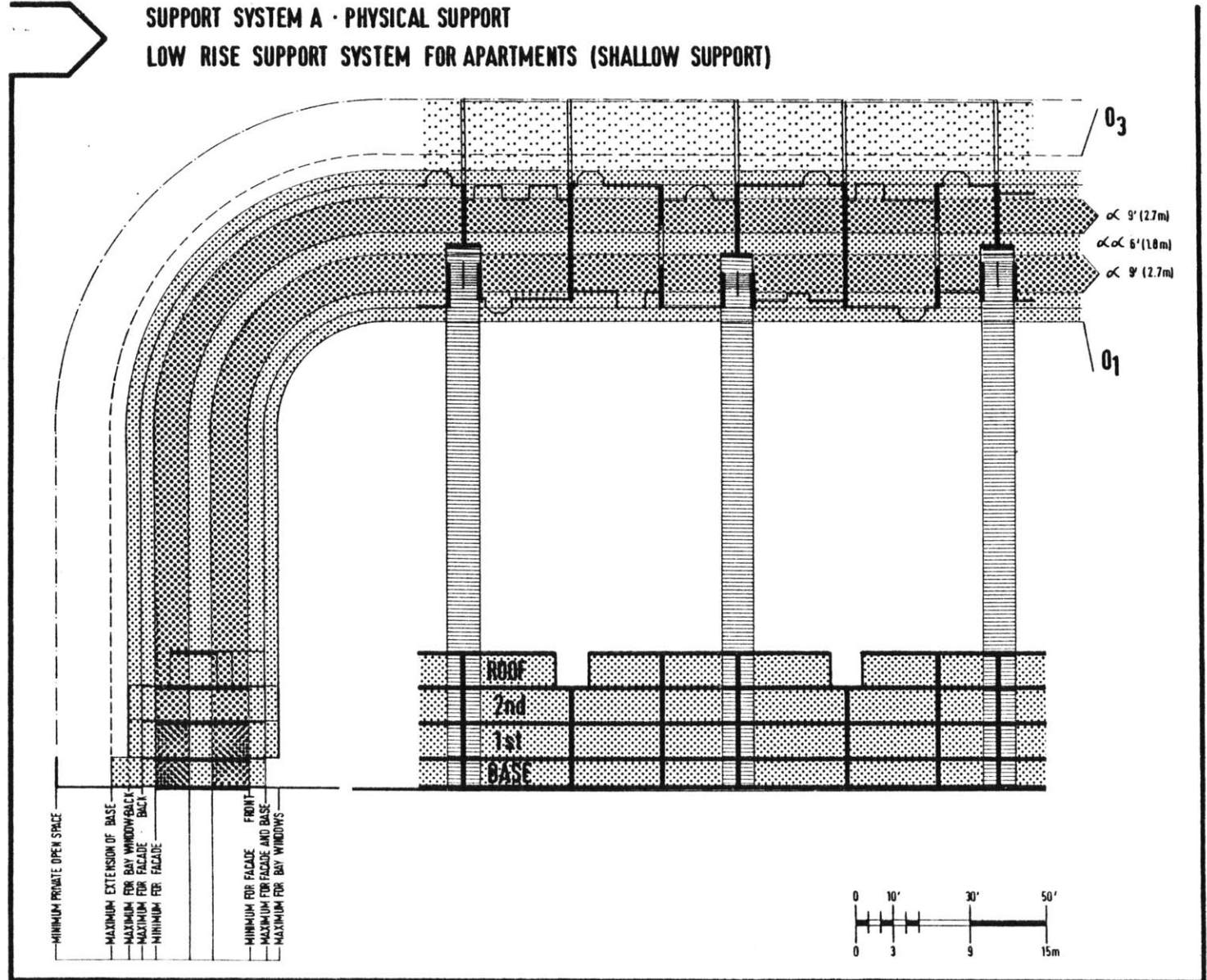
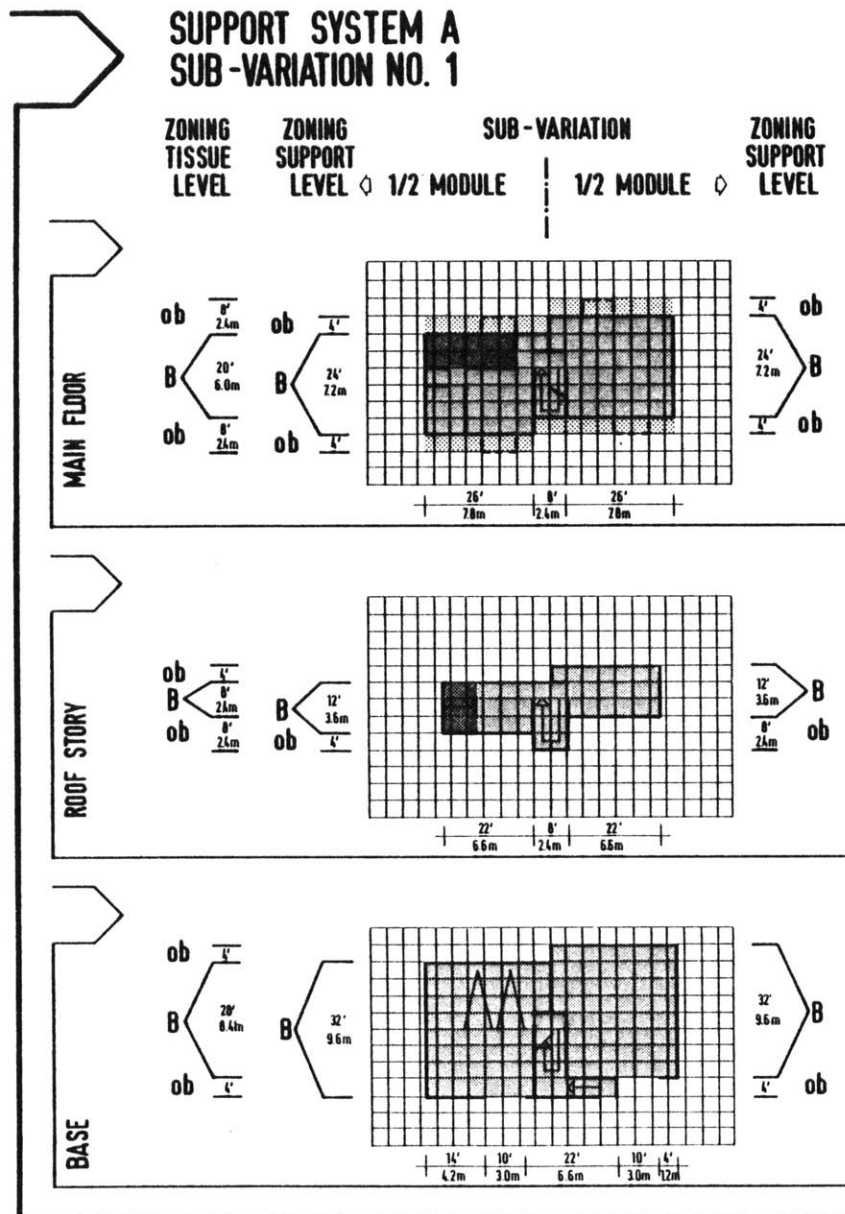

Fig. 107

Floor area, including staircase area, per 1/2 module or main floor:

	Proportion Width x Depth	Square Feet Square Meters Brutto	Square Feet Square Meters Netto	Number of Bedrooms
I Type A ₁	24' x 30' 7.2 m x 9.0 m	720 64.8	576 51.84	1
II Type A ₂	28' x 28' 8.4 m x 8.4 m	784 70.56	627 56.5	1
III	28' x 32' 8.4 m x 9.6 m	896 80.6	717 64.5	2
IV	40' x 24' 12 m x 7.2 m	960 86.4	768 69.12	2
V	36' x 28' 10.8 m x 8.4 m	1008 90.7	806 72.57	2
VI	40' x 28' 12 m x 8.4 m	1120 100.8	896 80.64	3
VII	36' x 32' 10.8 m x 9.6 m	1152 103	921 82.9	3
VIII	42' x 28' 12.6 m x 8.4 m	1176 105.8	940 84.6	3
IX Type A ₃	40' x 32' 12 m x 9.6 m	1280 115.2	1024 92.16	4



SUPPORT MODULE DATA FOR 1/2 MODULE

2 main floors
 1-bedroom apartments on each floor
 2 apartments per main floor area
 1 studio in roof story
 Total residential capacity: 3 units
 Total floor area: 1149 sq² ft.
 131.6 m²

Parking capacity:
 3 units required
 2 units in base
 1/2 unit outside parking
 1/2 unit additional required

Base:
 1 lobby entrance for two 1/2 modules
 1 curb cut per 1/2 module

Fig. 108

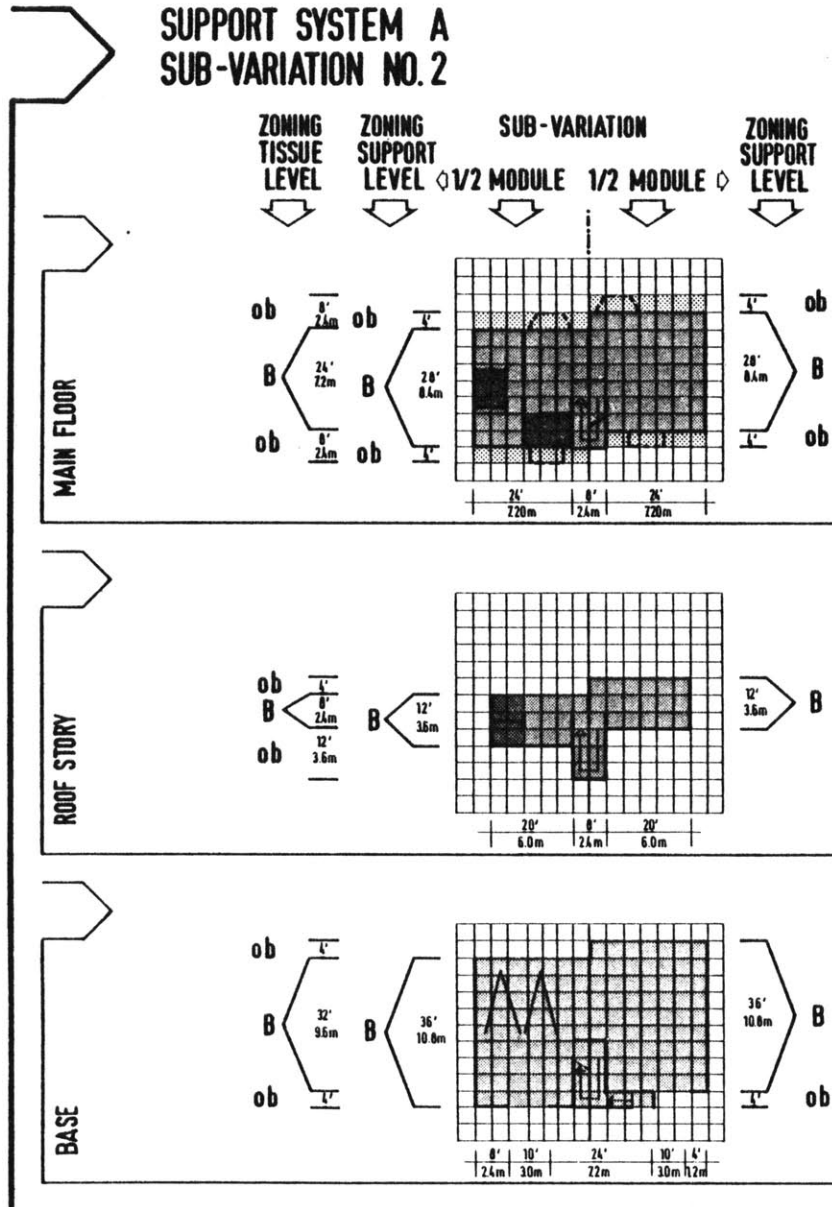

SUPPORT MODULE DATA FOR 1/2 MODULE

- 2 main floors
- 2-bedroom apartments on each floor
- 1 studio in roof story
- Total residential capacity: 3 units
- Total floor area: 1472 sq. ft.
137 m²
- Parking capacity:
- 3 units required
- 2 units in base
- 1/2 unit outside parking
- 1/2 unit additional required
- Base:
- 1 lobby entrance for two 1/2 modules
- 1 curb cut per 1/2 module

Fig. 109

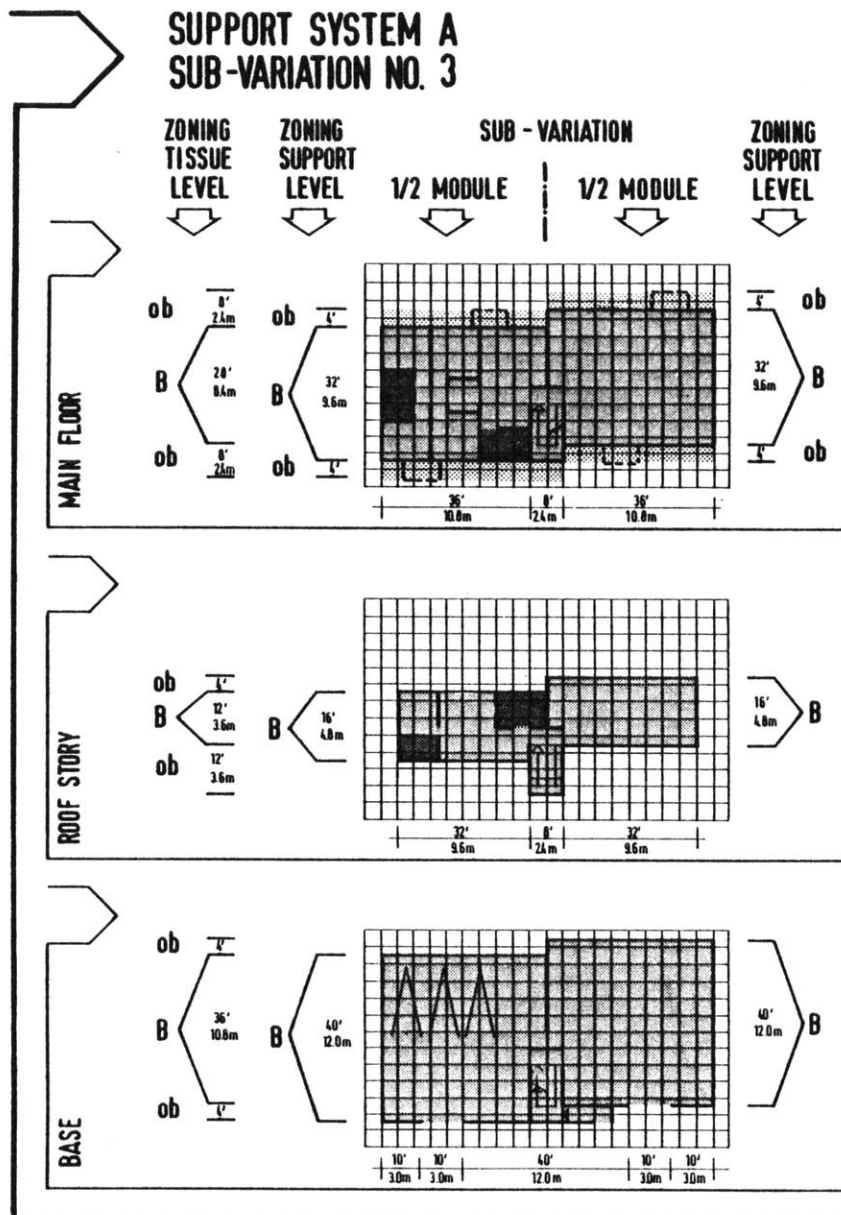

SUPPORT MODULE DATA FOR 1/2 MODULE

2 main floors
 4-bedroom apartments on each floor
 1-bedroom apartment in roof story
 Total residential capacity: 3 units
 Total floor area: 2656 sq. ft.
 236 m²

Parking capacity:

3 units required

3 units in base

Base:

1 lobby entrance for two 1/2 modules

1 curb cut per 1/2 module

Fig. 110

Dimensions of the existing street grid and location of built elements along major streets limit the depth of courtyard support structures. Shallow structures may be necessary to enable the location of supports inside the block. To provide sufficient open space between inner structures and built elements along major streets, Support System A is designed as a shallow type. It has a minimum depth of 24' (7.2 m) for the B-zone (support level) and a maximum depth of 32' (9.6 m).

The main floor area has γ - and $\gamma\alpha$ -margins, each with a depth of 4' (1.2 m) for bay windows or balconies. (Fig. 107) This system is based on common staircase access, from which the individual units can expand in different widths, based on a 2' (0.6 m) module. This system provides for the installation of detachable units of varying sizes and proportions. The arrangement permits front facade modulation by set-backs, as well as variable distances between separate staircases. These different sub-variation combinations must be positioned within the given tissue zoning which may vary in position and dimension of B-zones and ob-margins.

Figure 111 shows the different location possibilities for modules of Support System A. Each diagram shows a zoning distribution for the main floor

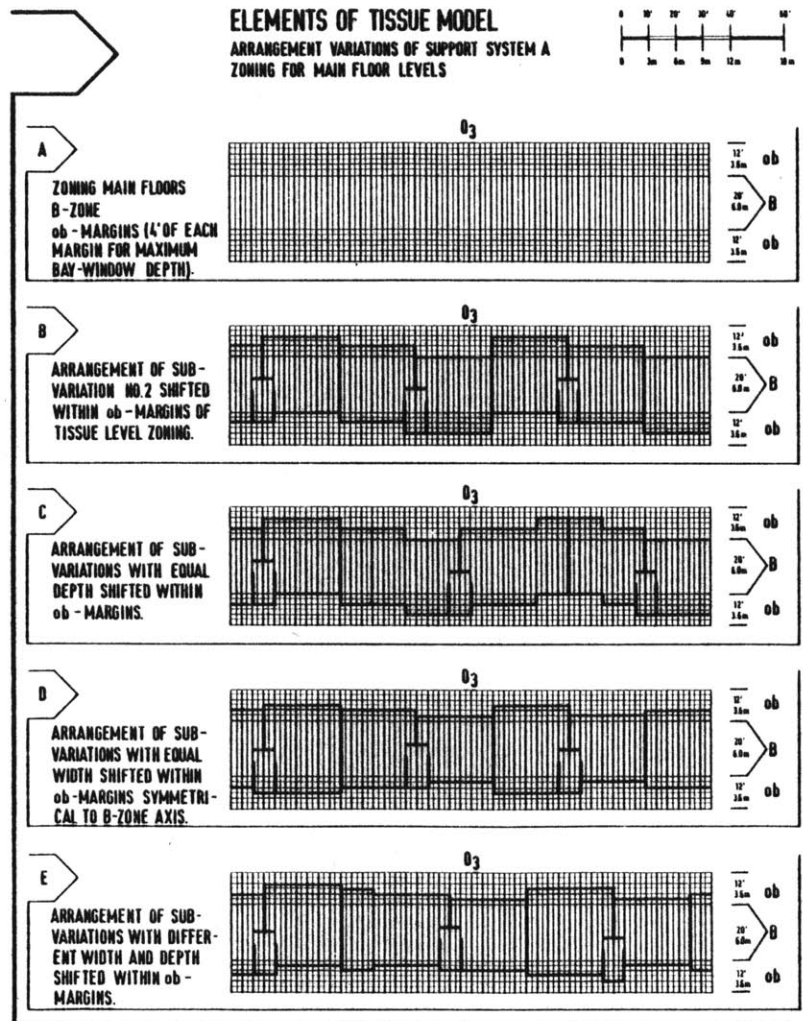

Fig. 111

level. Combined B- and ob-spaces are 44' (13.2 m) deep, consisting of a 20' (6.0 m) B-zone and two 12' (3.6 m) ob-margins. These dimensions are related to the tissue level and provide breaks in the continuity of the facade line, using different sub-variations or locating sub-variations of the same depth with different set-backs from the sidewalk.

Depth of the front facade modulation may be regulated by the dimensions of ob-margins. The deeper these margins become, in relation to the built zone, the more location of facade elements may vary. The examples provided indicate an 8' (2.4 m) shifting margin for the facades; an additional 4' (1.2 m) margin is provided on each side for the installation of bay windows.

This system may be arranged with a continuous facade line as well as one with set-backs. It can be also applied to sectors along major streets, where shallow floor plans are necessary and shifting of the front facade, without recess margins, is regulated by the tissue model.

3.422

THE NON-PHYSICAL SUPPORT — SUPPORT SYSTEM B

This system, shown in Figure 112, is designed to be used along major streets for both infill projects and new developments which must relate formally to the existing streetscape morphology. For these reasons, this system has assimilated the characteristics, such as set-backs, recesses, bay windows and side clearances, of single buildings around Alamo Square and enables unit arrangements which relate to the existing morphology.

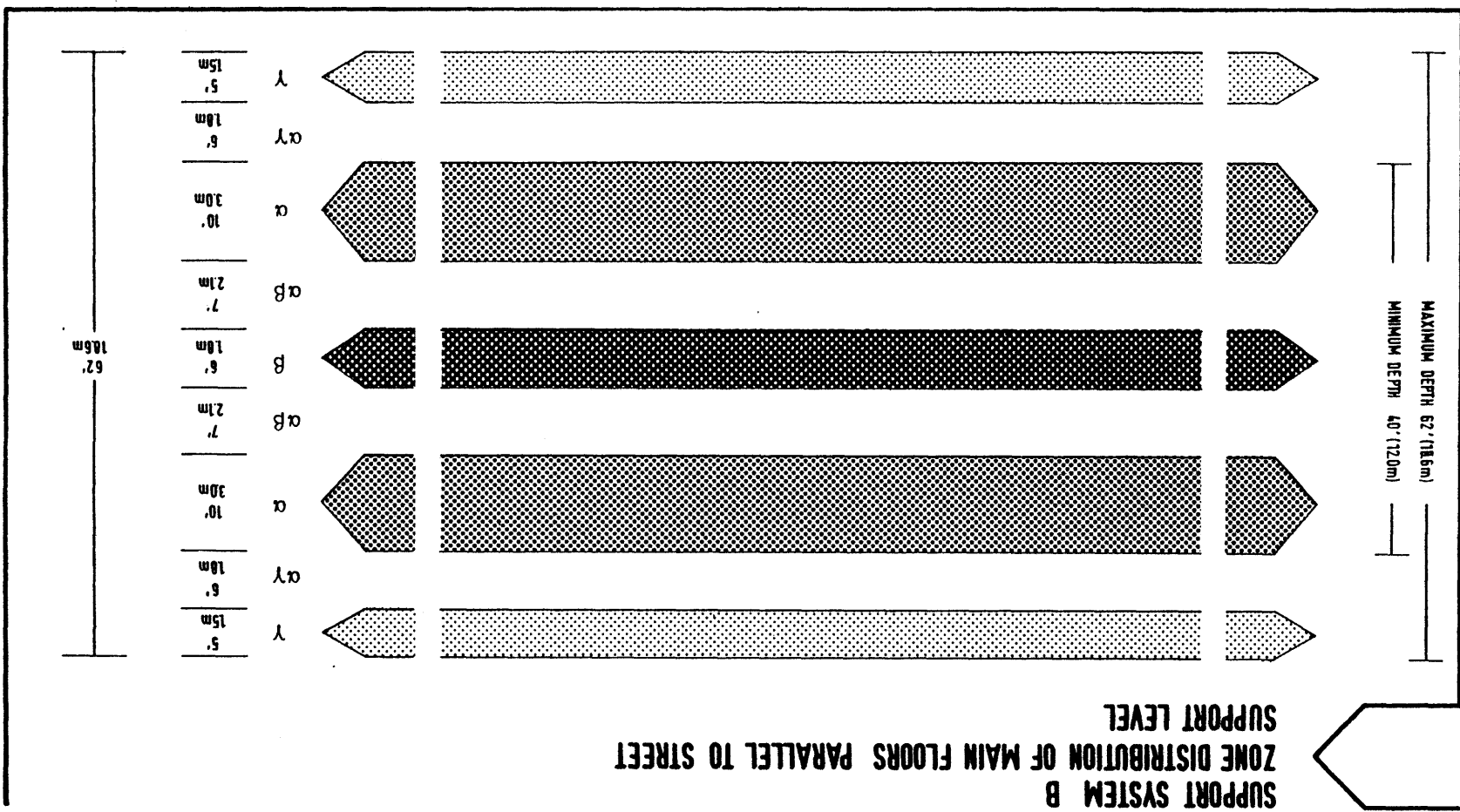

Support System B regulates the position of built elements with a zoning distribution both parallel and perpendicular to the street, based on a 4' (1.2 m) module. (See section 2.257)

A zoning system parallel to the street permits the arrangement of built elements with deep floor plans. B-zone depth (support level) may vary between 40' (12 m) and 62' (18.6 m), regulated by an α -margin and a γ -zone on each side. The distribution of this zoning system is based on that of the supports, as indicated in Variations.¹⁷

This system regulates the position of functions to provide enough flexibility for the development of different kinds of individually built supports. This system is not based on a specific physical construction.

The development of the zone distribution presented in Figure 112 is based on a space and function analysis made in a typology of dwellings and townhouses for the San Francisco Study. The proposed zoning distribution does not include a physical support related zoning and sector analysis. It generalizes the possibilities of arrangement for certain spaces within the given zoning distribution.

The following general space distributions are recommended for this support:

Sectors of the zones are planned to function as either general purpose spaces, such as living rooms, or special purpose spaces,

¹⁷Ibid., p.

such as bedrooms, according to the specific organization of the single unit.

The area of the β -zone and $\alpha\beta$ -margins is reserved for service spaces such as kitchens and bathrooms.

Depending on the situation of the existing morphology, the zoning distribution parallel to the street may be interrupted by a zoning system perpendicular to the street containing O-zones, B-zones, and ob-margins. O-zones assimilate existing side clearance situations and permit the arrangement of alley circulation. Ob-margins contain recess and circulation elements, and B-zones are reserved for built spaces of various residential and commercial functions.

The following examples of townhouse types are based on the zoning distributions of Support System B. Four townhouse types with different capacities and circulation patterns were developed as examples of infill structures and possibilities for further density studies of the tissue models.

The zoning distribution perpendicular to the street is based on a 4' (1.2 m) module. All townhouse types have a built zone perpendicular to the street of 16' (4.8 m) or two ob-margins, each with a maximum width of 8' (2.4 m). Figure 113 indicates the general zone distribution. It permits relatively narrow sectors such as in Type 1, a single family house which has only one ob-margin of 4' (1.2 m) for internal staircase circulation in addition to the B-zone of 16' (4.8 m).

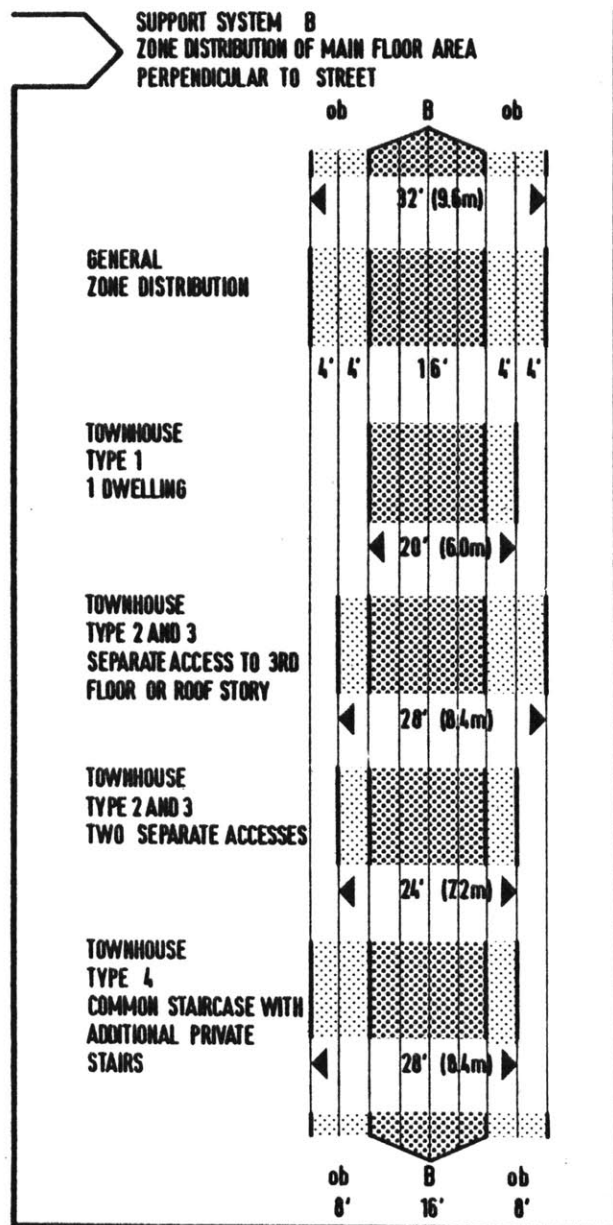

Fig. 113

Within this system it is possible to vary access patterns, as well as the width of residential space of a sector, by utilizing spaces of adjacent $\alpha\beta$ -margins. This can extend the B-zone of a sector from 16' (4.8 m) to 20' (6.0 m) and even to 24' (7.2 m). (See Type 4)

Figure 114 indicates the location of spaces in relation to the zoning distribution parallel to the street on the support level. Kitchens and bathrooms are located in the β -zone and extend into the space of adjacent $\alpha\beta$ -margins. Living rooms are located in the front α -zones and in adjacent $\alpha\beta/\alpha\gamma$ -margins, while bedrooms dominate the rear α -zone and adjacent $\alpha\gamma$ -margin.

SUPPORT SYSTEM B
ZONE DISTRIBUTION OF TOWNHOUSES · TYPES 1 TO 4 · 1ST FLOOR AREA

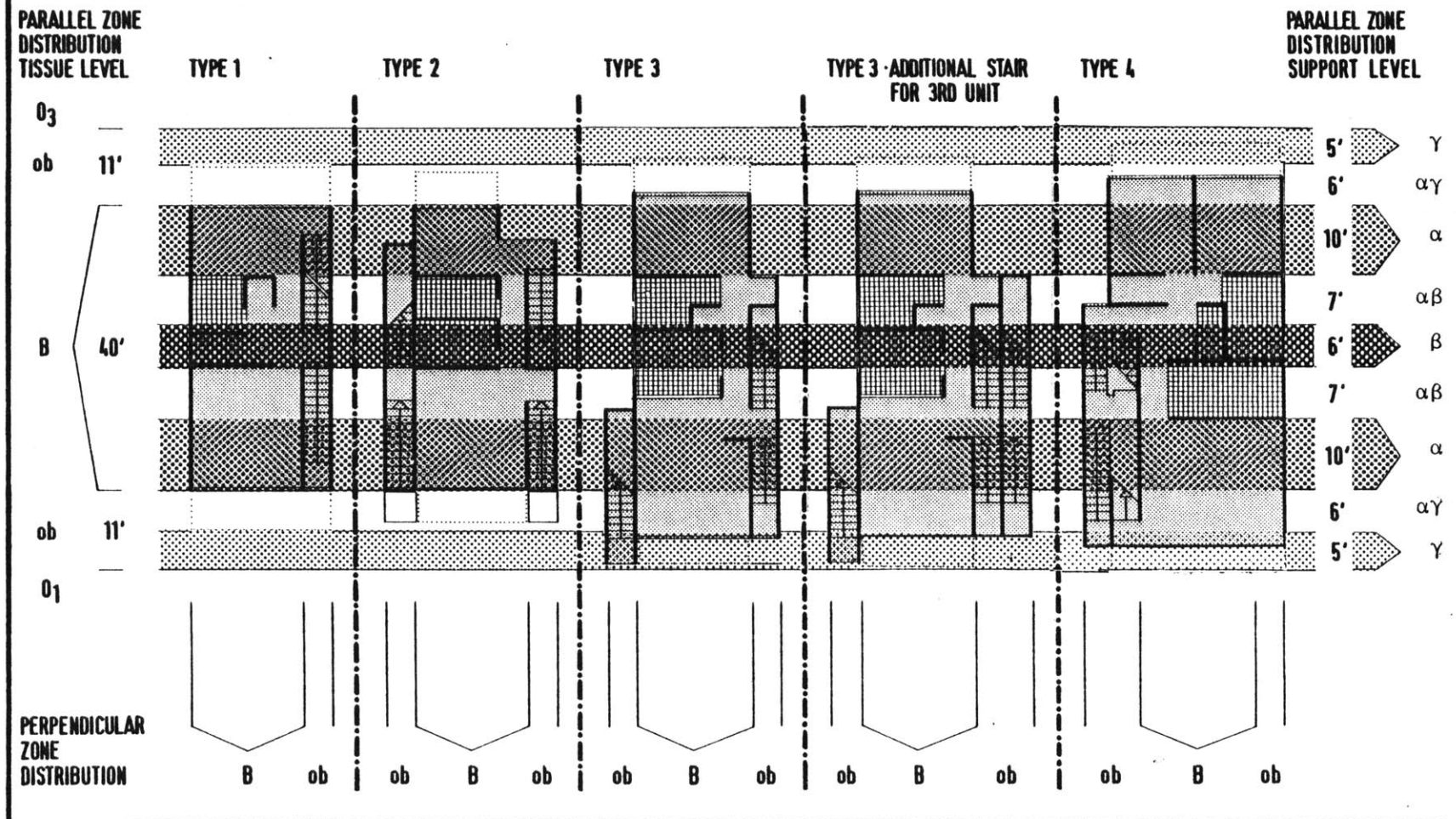

Fig. 114

3.423

SECTOR EXAMPLES FOR TOWNHOUSES, ACCORDING TO THE ZONING DISTRIBUTION OF SUPPORT SYSTEM B

Townhouse Type 1. This townhouse type, shown in Figure 115, was conceived of as a one-unit sector. It is a very narrow dwelling 20' (6.0 m) wide.

The proposed floor plan arrangement contains a living room, dining room, kitchen and half-bath on the first floor. The second floor has a master bedroom, two smaller bedrooms, and two bathrooms. The roof story contains additional space to be used for various purposes. Figure 115 presents an arrangement of a small living room, a bedroom, a kitchen and a bathroom for the roof story.

The roof story can be reached by the staircase in the ob-margin. This townhouse type provides no separate access for the different floors. A second staircase will require an additional ob-margin of 4' (1.2 m).

This townhouse type has a floor area* of 640 sq. ft. (57.6 m²) per main floor and provides an additional roof space of 384 sq. ft. (35 m²).

The section drawing is reduced to 50% of the floor plan scale and indicates the distribution of built spaces and ob-margins for bays in front and back.

* Floor area = netto area (total surface area - 20% for construction elements (walls, etc.))

SUPPORT SYSTEM B TOWNHOUSE TYPE 1 · FLOOR PLANS · SECTION

FLOOR PLANS

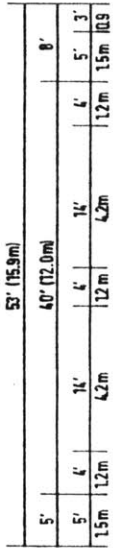

BASE

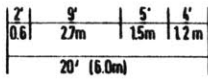
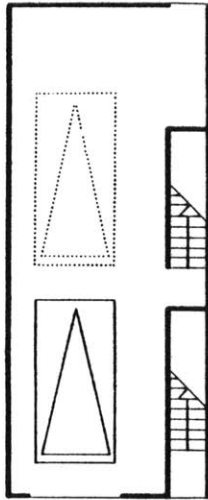

1ST FLOOR

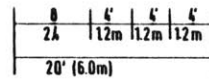
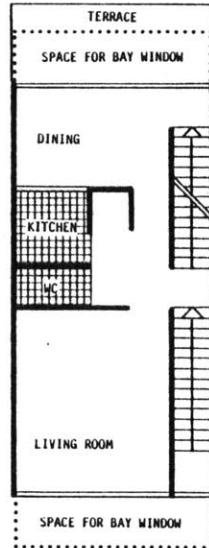

2ND FLOOR

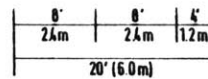
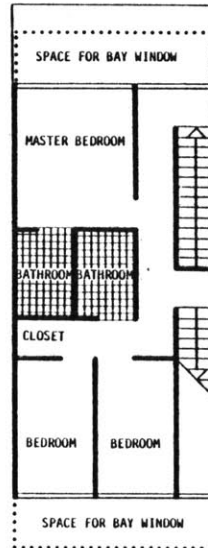

ROOF STORY

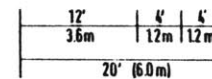
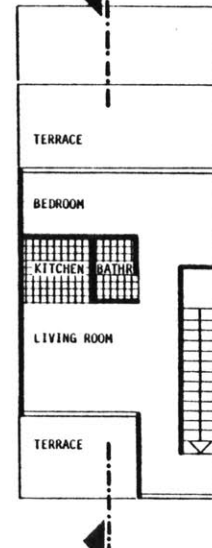

SECTION

ROOF STORY

2ND FLOOR

1ST FLOOR

BASE

01

03

Fig. 115

Townhouse Type 2. Shown in Figure 116, Townhouse Type 2 was conceived of as a sector containing two or three units. The three-unit type will require an additional staircase, if separate access to each unit is required.

The two-unit sector is 24' (7.2 m) wide and 52' (15.6 m) deep. The main floor may contain a one-bedroom apartment. A floor plan for a two-bedroom apartment is provided and can be used if access to another floor is not necessary.

Figure 116 also presents floor plans for a two-unit sector with the location of dwellings as shown in Alternative III. Living areas for two separate apartments, Units A and B, are located on the first and second floors. The second floor also contains a bedroom which is connected by a staircase to the lower level of Unit A. The third floor contains bedrooms for Unit B. An arrangement of spaces as in Type 3 is also possible. An extension of living space for Unit B is provided in the roof story.

The average floor area for each main floor is 624 sq. ft. (56.3 m²), which generates a unit size of 936 sq. ft. (84.24 m²) for Unit A and 1192 sq. ft. (107.3 m²) for Unit B, including the roof story of 256 sq. ft. (23.5 m²), for Alternate III.

The section drawing is reduced to 50% of the floor plan scale and indicates the possible distributions of units. Type 2 is characterized by a closed entrance element which requires a setback of 5' (1.5 m).

SUPPORT SYSTEM B TOWNHOUSE TYPE 2 · FLOOR PLANS · ALTERNATIVES OF DWELLING ARRANGEMENTS

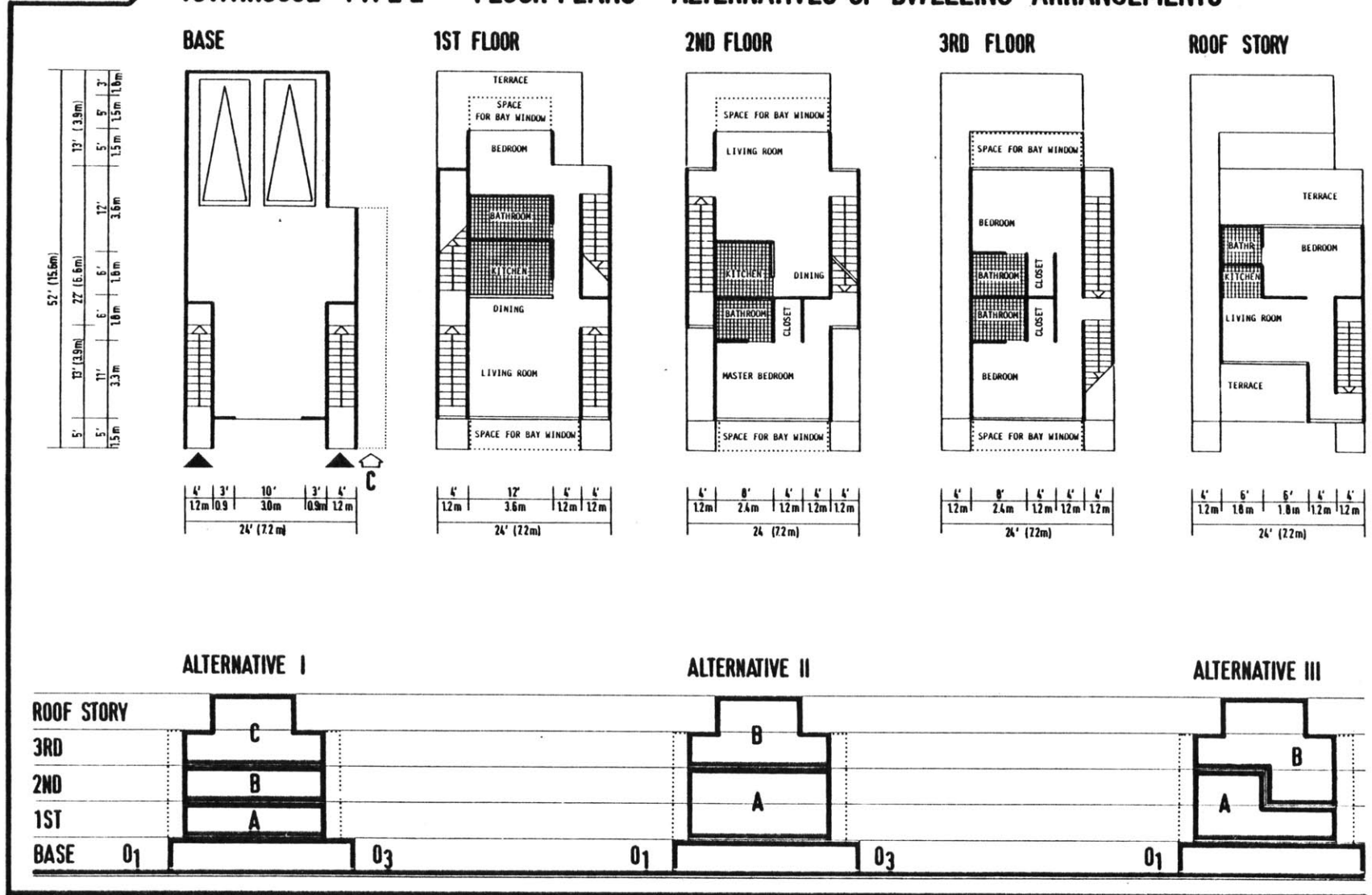

Fig. 116

Townhouse Type 3. Shown in Figure 117, this townhouse type is a deeper version of Type 2. The added depth enables an increase of service space areas: the kitchen and bathrooms. Types 3 and 4 have a deep service space area created by the arrangement of bathroom groups for two units of the third floor, extending service space depth to 16' (4.8 m) plus circulation on each side.

The floor plans in Figure 117 indicate the distribution of units as shown in Alternative III. The living areas and master bedrooms are located on the first and third floors. The second floor is shared by both units and used for bedrooms and bathrooms.

This type is characterized by an open staircase on the base level which requires a set-back of 14' (4.2 m). A different staircase arrangement could reduce the set-back depth to 10' (3.0 m).

The main floor area of Type 3 averages 800 sq. ft. (72 m²) and can contain separate two-bedroom units. Alternative III creates a floor area for Unit A of 1196 sq. ft. (107.7 m²). Unit B covers an area of 1276 sq. ft. (114.9 m²) on the second and third floors and extends into the roof story with an area of 448 sq. ft. (40.32 m²).

The sections are reduced to 50% of floor plan scale and indicate the possible distributions of units.

SUPPORT SYSTEM B TOWNHOUSE TYPE 3 · FLOOR PLANS · ALTERNATIVES OF DWELLING ARRANGEMENTS



Fig. 117

Townhouse Type 4. This type, shown in Figure 118, differs from other types presented. It has a shared staircase and separate interior stairs which provide private vertical circulation for single units in the support. This variation provides access from the common staircase to units located on different levels. If sectors of Type 4 are combined, the common staircase can serve two sectors. Sector elements may step with the slope in a one-floor or half-floor rhythm. The dog-legged stair provides access from landings on each half-floor level to adjacent units. If units are arranged as duplexes (maisonettes), they may have an interior staircase to provide private inner circulation.

Floor plans in Figure 118 indicate an arrangement of three units as shown in Alternative III. Units A and B are large four-bedroom apartments with living areas on the first and third floors. They are organized in a duplex or maisonette arrangement and have separate private staircases to the second floor which they share as bedroom space.

The main floor area covers 998.4 sq. ft. (90 m²) and provides space for a two-bedroom apartment. The total area of Units A and B is 1497.6 sq. ft. (135 m²) each. The roof contains a separate one-bedroom unit of 576 sq. ft. (51.9 m²).

The combination of a common staircase with private stairs for maisonette arrangement provides a wide range of possibilities for locating individual units. A few examples are presented in the section drawings which are reduced 50% from floor plan scale.

SUPPORT SYSTEM B TOWNHOUSE TYPE 4 · FLOOR PLAN · ALTERNATIVES OF DWELLING ARRANGEMENTS

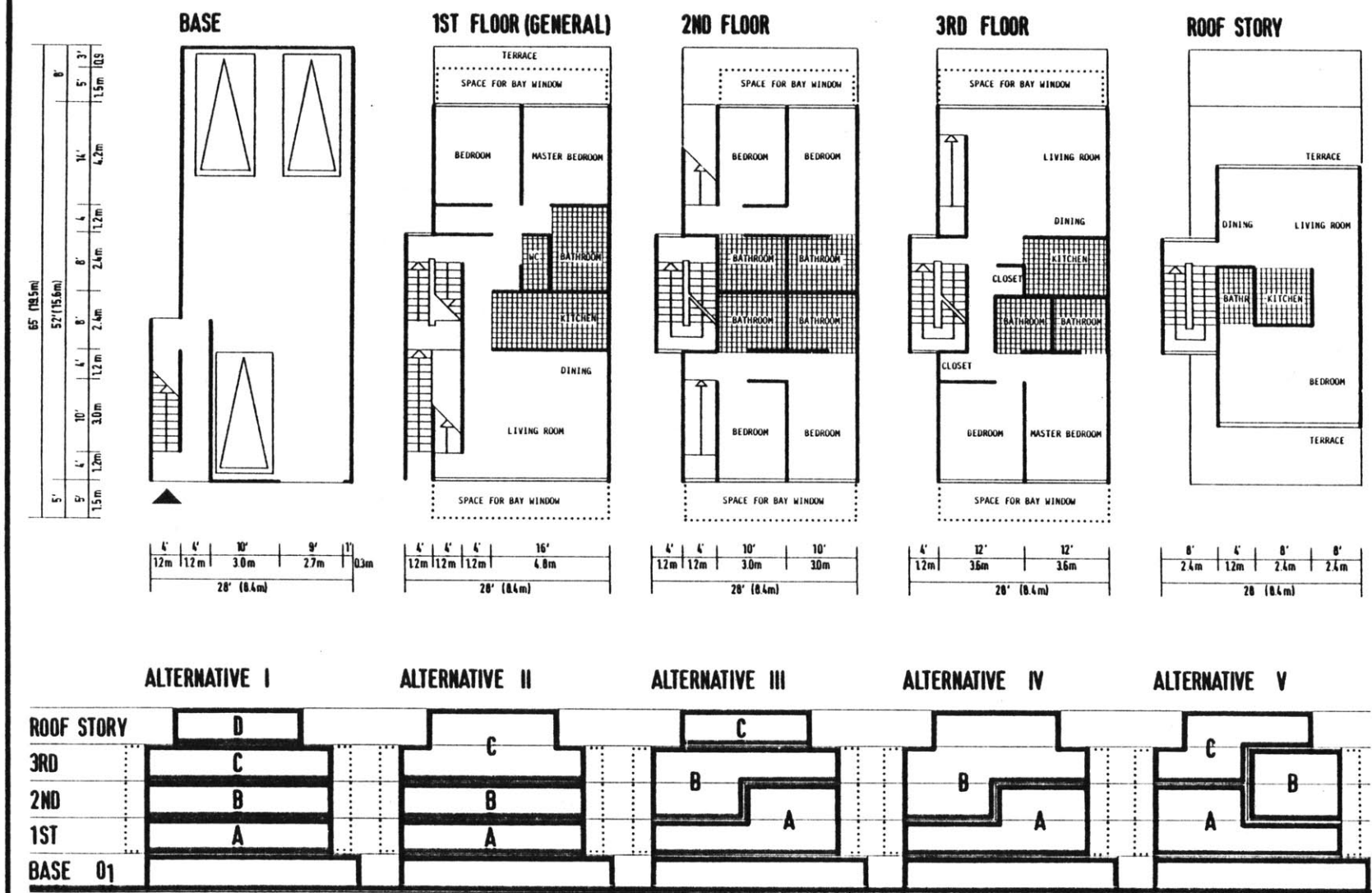

Fig. 118

SUPPORT SYSTEM B

ZONE DISTRIBUTION OF TOWNHOUSES - TYPES 1 TO 4 - 1ST FLOOR AREA

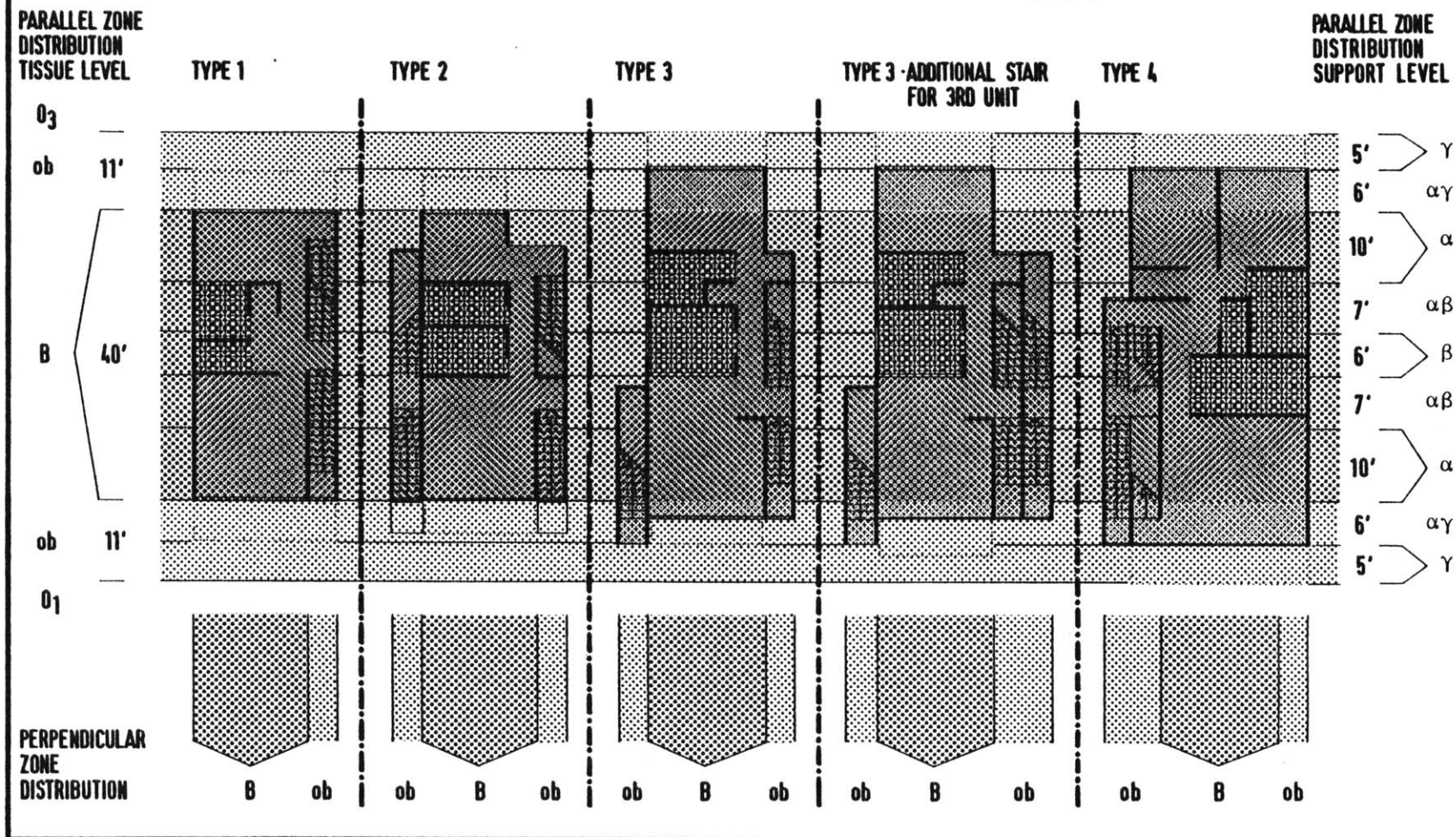

Fig. 119

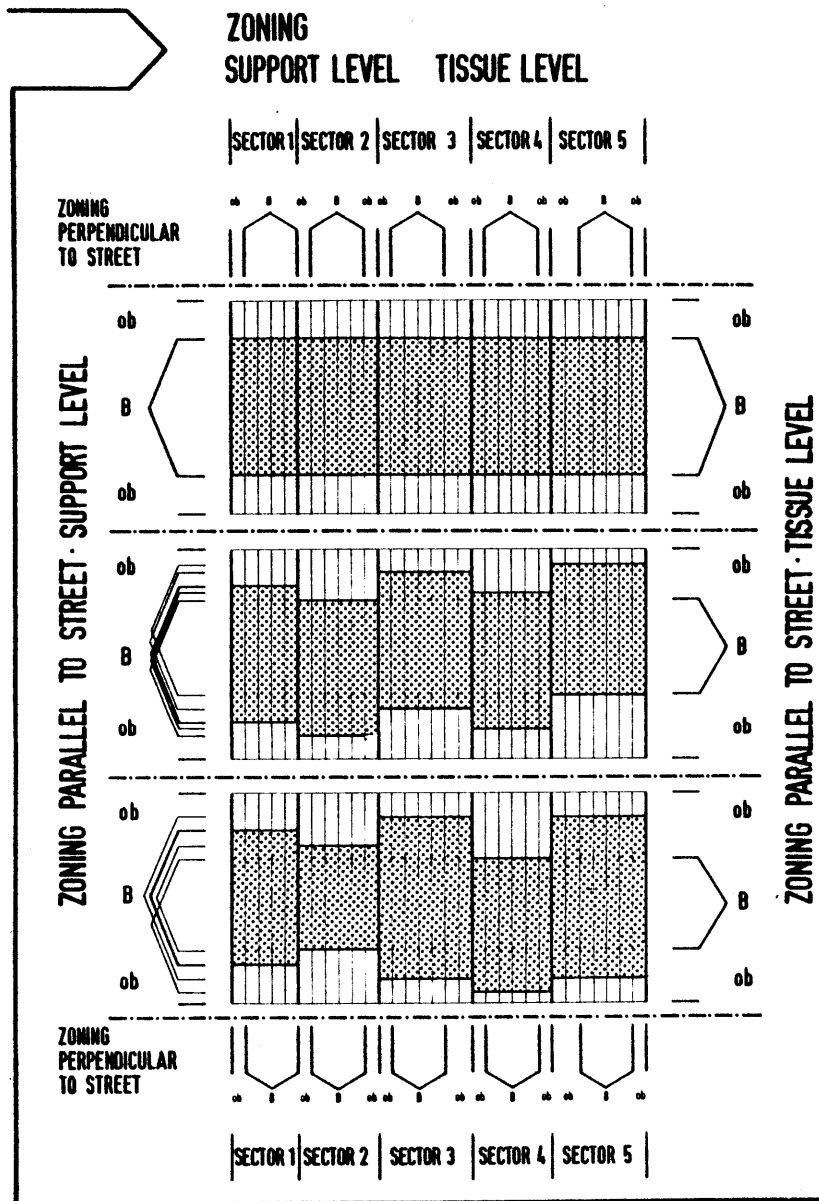

Fig. 120

For the application of the townhouse type in the tissue model, the zoning distribution on the support level, shown in Figure 114, will become less important than the dimensions of the zoning system on the tissue level. On the support level, Support System B differentiates nine different zones and margins which have specific dimensions, locations and functions. The zone distribution on the tissue level differentiates only three zones: B-zones, ob-margins and O-zones. For this study, the γ -zone and the $\alpha\gamma$ -margin of the support zoning are combined to form an ob-margins for the tissue zoning. The β - and α -zones and adjacent margins of the support zoning are combined to form a B-zone for the tissue level.

Figure 119 provides a location example for the four different townhouse types in a continuous Support System B. All types fill the B-zone, but extend with different dimensions into the ob-margins. The bottom of the diagram indicates the zoning distribution perpendicular to the street for each individual type. General zoning of Support System B requires a depth of 40' (12 m) for the B-zone and 11' (3.3 m) for the ob-margins in front and in back. The total depth of this zoning system is 62' (18.6 m).

If the support system is a continuous band, all built elements must be located within these margins. A variable position for the support would generate deeper margins for the tissue level (Fig. 120).

The physical examples provided for Support System B are town-house types. For the further development of the tissue model and its application, it is important to mention that this non-physical zoning system also regulates the location and dimension of apartment buildings. The 62' (18.6 m) maximum depth for the continuous zoning band provides even central corridor systems, which must be at least 55' (16.5 m) deep to be economical.

If such developments are infill projects in the existing fabric, they should be located at corners and fulfill the rules provided in the proposed agreements for the development of tissue models. This could guarantee an adaptation of the existing fabric to the general patterns by assimilation of the morphological scale of its elements. It would permit the concentration of smaller units.

Within the proposed tissue model, it will be possible not only to revitalize the morphological aspect of this region, but to provide functions and dimensions of new built elements which relate to modern urban living and its requirements.

3.43

TISSUE MODEL OF TISSUE TYPE I_A

The general rules for the development of tissue types and function models, Rules 1 to 7, generate a zoning distribution as notated in Figure 121. The arrangement of zones is based on the generic Victorian closed building block tissue pattern.

The new tissue model increases the depth of ob-margins and reduces the depth of the B-zone to provide for the use of less deep supports and the possibility of deep set-backs. The total depth of the B-zone and ob-margins is 68' (20.4 m), a dimension which permits very deep floor plans. This depth is shallow, however, when compared to the zoning distribution of the Victorian tissue (Fig. 92) which had a total depth of 105' (32 m). As a result, the new tissue model increases courtyard space, the O₃-zone, from 14% to 37.8% of the total block area.

Figure 122 indicates maximum and minimum dimensions of built elements. The entire block is framed by a 5' (1.5 m) ob-margin which extends over the sidewalk area and is reserved for bays and balconies only. The interior location area has a maximum set-back depth of 20' (6 m), which includes the bay window margin. To emphasize corners, set-back depth is reduced to a maximum of 12' (3.6 m). The tissue model regulates a minimum height of two main floors for built elements in interior street locations and three main floors, with the option to add one main floor and a roof story, for built elements in corner locations.

Figure 123 indicates the minimum and maximum dimensions of thematic spaces.

The tissue model of Tissue Type I_A may be quantified as follows:

A. Coverage

Interior B-zone	24,752 sq. ft.	(2,228 m ²)
Interior ob-margins (50%)*	15,504 sq. ft.	(1,395 m ²)
Corner B-zone	8,928 sq. ft.	(804 m ²)
Corner ob-margins (50%)*	2,880 sq. ft.	(259 m ²)
<hr/>		
TOTAL COVERAGE	52,064 sq. ft.	(4,686 m ²)
	(45% of the generic block space, 275' x 412'6", if ob-margins are considered by 50% coverage of built elements)	
 O ₃ -area	61,236 sq. ft.	(5,511 m ²)
	(37.8% of the generic block space)	

* The density study assumes that 50% of the ob-margins will be built.

B. Density Alternatives

I. Interior street location (2 main floors + roof story)	105,264 sq. ft.	(9,474 m ²)
Corner street location (3 main floors + roof story)	44,352 sq. ft.	(3,992 m ²)
<hr/>		
TOTAL FLOOR AREA	149,616 sq. ft.	(13,465 m ²)
FAR*		1.3
(in relation to generic block area of 113,437 sq. ft. [10,209 m ²])		
80% of total floor area**	119,693 sq. ft.	(10,772 m ²)
FAR* (considering 80% of total floor area)		1.05
II. Interior street location (3 main floors + roof story)	145,520 sq. ft.	(13,097 m ²)
Corner street location (4 main floors + roof story)	56,160 sq. ft.	(5,054 m ²)
<hr/>		
TOTAL FLOOR AREA	201,680 sq. ft.	(18,151 m ²)
FAR*		1.77
80% of total floor area**	161,344 sq. ft.	(14,521 m ²)
FAR* (considering 80% of total floor area)		1.42

* Floor Area Ratio (Geschossflächenzahl)

** The zoning distribution perpendicular to the street decreases building coverage of a B-zone by an average of 20%.

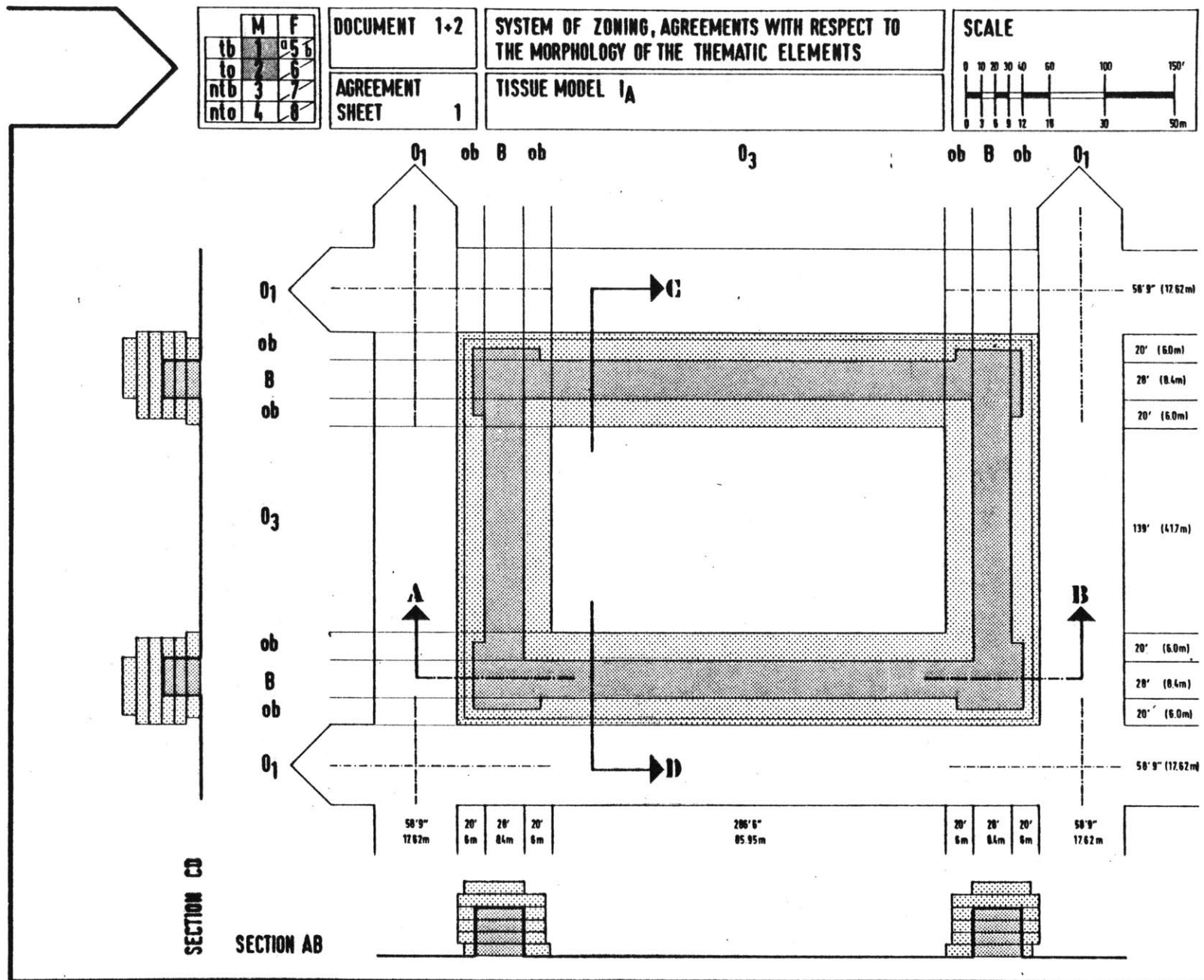

Fig. 121

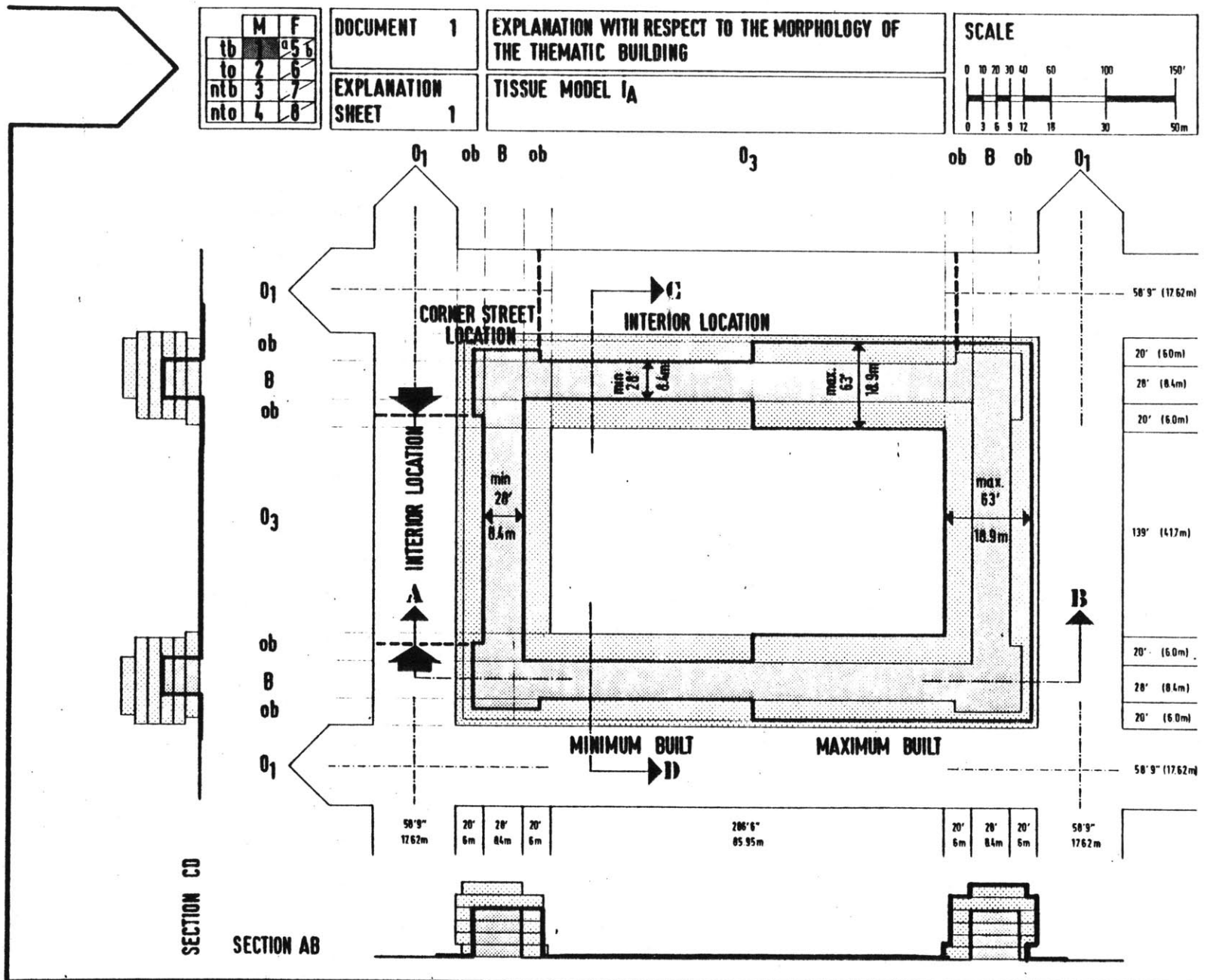

Fig. 122

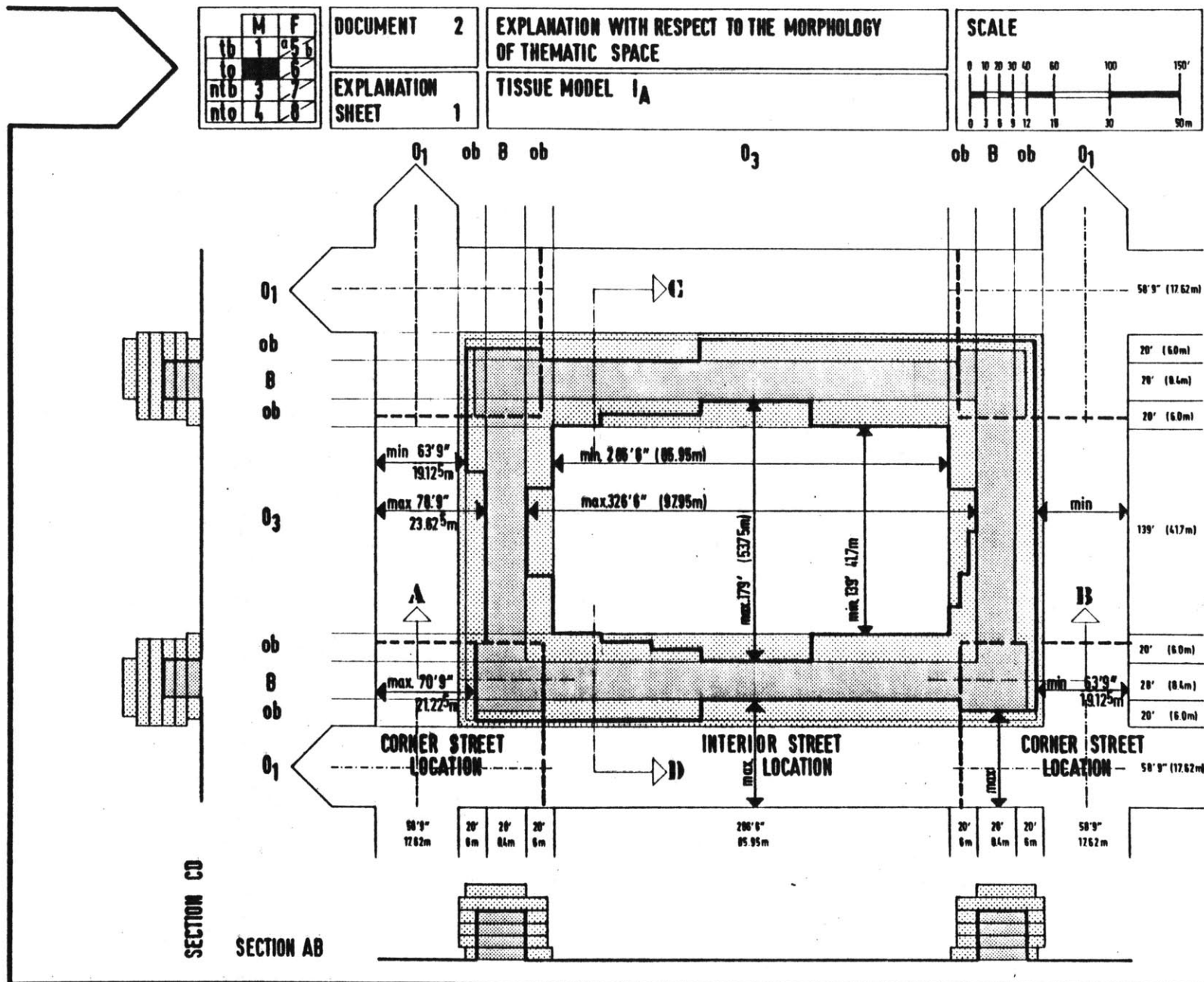

Fig. 123

3.44

TISSUE MODEL OF FUNCTION MODEL IV_{C2} BASED ON GENERAL ZONE AND BLOCK DIMENSIONS

Using Tissue Model I_A as a starting point for a zoning distribution of the built block along main streets, this tissue model adds two built elements in the inner block area. These two built elements provide additional residential space and divide the inner block into three separate open spaces. In Figure 123, two O₃-spaces have the same size and are arranged symmetrically in the block. In the center is an O₂-space with a width of 54'6" (16.35 m), containing alley circulation.

For an alley with one driving lane, two parking lanes and two sidewalks, the tissue rules require a width of 38' (11.4 m). (See Fig. TR 11.) An additional 16' (4.8 m) space allows a slight turn of the alley and more differentiated landscaping in the O₂-zone. (Fig. 124)

The built elements in the inner block fulfill the regulations of building and distance from opposite buildings of Rule 5 (Support System A). (See Fig. TR 8.) Built elements along O₁-zones have the same minimum and maximum heights as in Tissue Model I_A. Type IV_{C2} differs from Type I_A by a larger capacity (because of the infill in the inner block), a discontinuity of the O₃-zone, and additional vehicular circulation in the block center.

This type also increases the netto floor area* by 14,592 sq. ft. (1313.2 m²) and changes the FAR by a factor of 0.13, which means 10% more available floor area.

* total floor area minus 20% because of perpendicular zoning.

The tissue model of Function Model IV_{C2} may be quantified as follows:

A. Coverage

Block frame interior B-zone	24,752 sq. ft.	(2,288 m ²)
interior ob-margins (50%)*	15,504 sq. ft.	(1,395 m ²)
corner B-zone	8,928 sq. ft.	(804 m ²)
corner ob-margins (50%)*	2,880 sq. ft.	(259 m ²)
Inner block B-zone	4,880 sq. ft.	(432 m ²)
ob-margins (50%)	1,920 sq. ft.	(173 m ²)
<hr/>		
TOTAL COVERAGE	58,784 sq. ft.	(5,291 m ²)
		(51% of generic block space)
 O ₂ - and O ₃ -areas	 54,653 sq. ft.	 (4,919 m ²)
		(48.2% of generic block space)

* This density study assumes that 50% of the ob-margins will be built.

B. Density Alternatives

I. Interior street location	(2 main floors + roof story)	105,264 sq. ft.	(9,474 m ²)
Corner street location	(3 main floors + roof story)	44,352 sq. ft.	(3,992 m ²)
Inner block location	(2 main floors + roof story)	18,240 sq. ft.	(1,642 m ²)
<hr/>			
TOTAL FLOOR AREA		167,856 sq. ft.	(15,108 m ²)
FAR			1.48
(in relation to generic block area of 113,437 sq. ft. [10,209 m ²])			
80% of total floor area*		134,284 sq. ft.	(12,086 m ²)
FAR (considering 80% of total floor area)			1.18
II. Interior street location	(3 main floors + roof story)	145,520 sq. ft.	(13,097 m ²)
Corner street location	(4 main floors + roof story)	56,160 sq. ft.	(5,055 m ²)
Inner block location	(2 main floors + roof story)	18,240 sq. ft.	(1,642 m ²)
<hr/>			
TOTAL FLOOR AREA		219,920 sq. ft.	(19,794 m ²)
FAR			1.93
(in relation to generic block area of 113,437 sq. ft. [10,209 m ²])			
80% of total floor area*		175,936 sq. ft.	(15,835 m ²)
FAR (considering 80% of total floor area)			1.55

* The zoning distribution perpendicular to the street decreases building coverage of the B-zone and ob-margins by an average of 20%

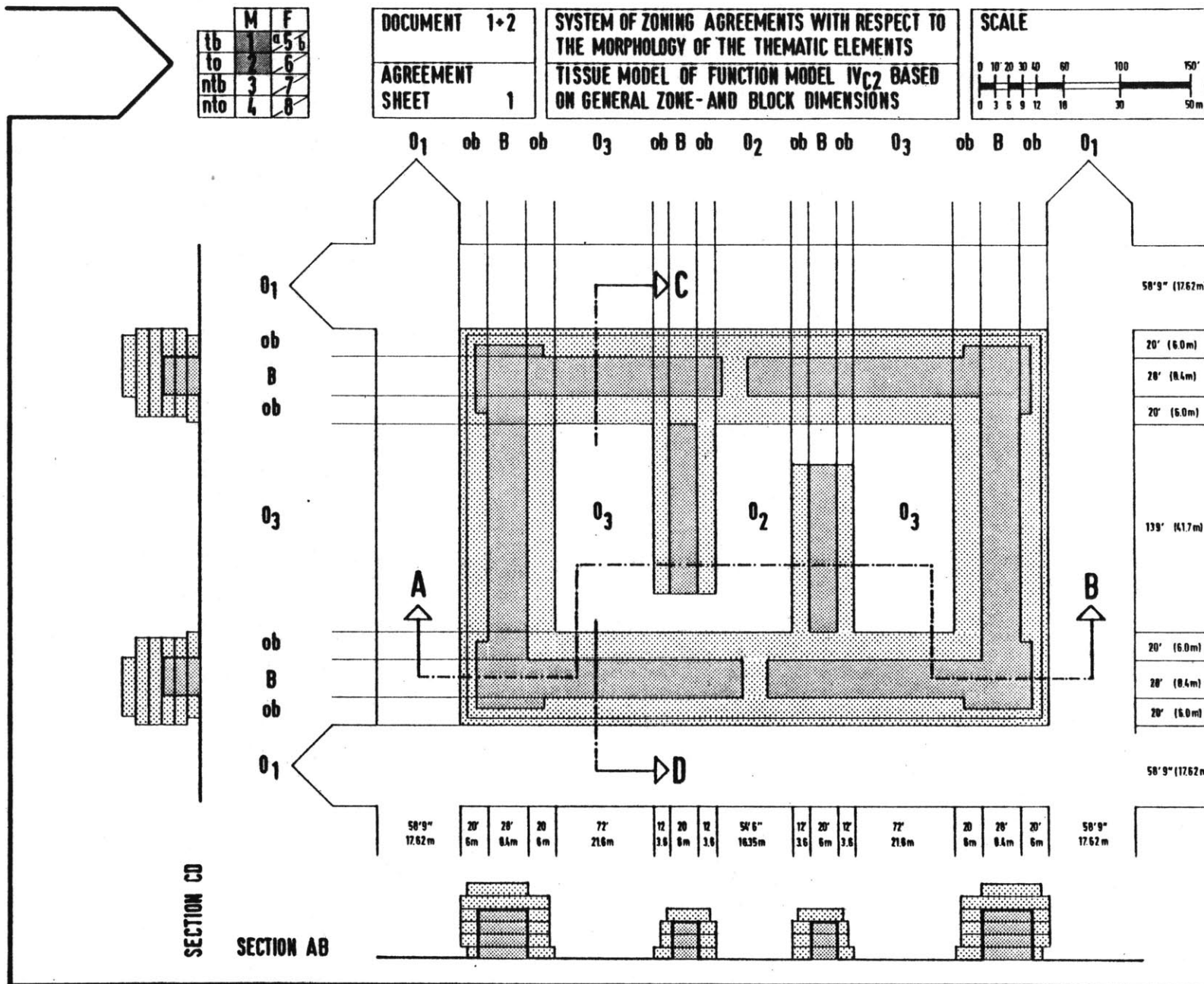

Fig. 124

3.55

TISSUE MODEL IV_{C2a}

The two previous tissue models are based on the generic block size of 275' x 412'6" (82.5 m x 123.75 m). Built elements in the inner block are oriented parallel to the shorter block sides. Building height, the fixed location of the O₁-zones, and their minimum width determine the width of O₂- and O₃-zones.

The first rule for the development of tissue models regulates the position of the street axis, but permits variations in the widths of major streets. Assuming that the built elements in the adjacent blocks along cross streets fit within the zoning pattern of the Victorian tissue, the positions of the short sides of the tissue model are extended by 5' (1.5 m) closer to the axis of the cross street. The area of Tissue Model IV_{C2a}, therefore, becomes 275' x 422'6" (82.5 m x 126.75 m). This leaves a 54'9" (16.42 m) width for the cross street O₁-zone, which permits a building height of four main floors plus a roof story. (See Fig. TR 8.) If the same tissue model is used on the opposite side of the cross street, the O₁-width becomes 48'9" (14.67 m). This would permit an arrangement of three story buildings only, if no further decisions are made about minimum set-back dimensions of higher buildings.

This third tissue model differs from the others in the dimensions of the B-zone and ob-margins. Although the depth of the zoning distribution of margins and the B-zone is one foot (0.3 m) less in Tissue Model IV_{C2a}, it provides more floor area

by its deeper B-zone. The decision for the dimensions of the zone distribution for the tissue level is based on the idea of demonstrating the density capacity of such a model and respecting the morphological constraints of the built environment.

The density analysis of the Alamo Square area indicated a homogeneity in the number of floors and land coverage for generic Victorian blocks. Block 821, for example, has a building coverage of 49.8% and contains 142 units; buildings in Block 822 cover 57.9% of the area and includes 147 units. The average land coverage of the existing Victorian block is around 55% and each block contains an average of 130 units.

New developments do not indicate this homogeneity. Some developments decrease building coverage by increasing the number of floors per building, as in Block 757; others reduce building coverage and FAR as well. For example, Block 820 A shows that it is possible to double the number of units per block by reducing the FAR and building coverage.

The present zoning regulations of San Francisco have emphasized low rise developments in this area (e.g., Blocks 796, 754, and 781). They imply fragments of suburban lifestyle in an urban environment.

One part of the revitalization must be the consideration of the "soft" patterns of the living environment which are based on aspects of human behavior and respect the criteria which make of people a community. The architectural quality of a living

environment can only catalyze in a positive manner the way people live together by offering spaces for social functions or shelter.

It is also important that the number of people, or density, is relative to the spaces where they are. Six persons in an elevator are a crowd, but not recognized as such in Fenway Park at game time. Buildings of one main floor may fit very well in rural and suburban areas, but not as the dominant element in urban environments (e.g., Blocks 754, 755). The appropriate size of the building envelope implies not only the degree of "urban-ness", but is also one important factor which determines density. New developments must show a consideration of this in their designs.

The first two tissue models presented varied in floor area from 119,692 sq. ft. ($10,772 \text{ m}^2$) to 175,936 sq. ft. ($15,834 \text{ m}^2$). Reducing these areas by 20%, the tissue models provide netto floor area of 95,753 sq. ft. ($8,617.8 \text{ m}^2$) to 140,748 sq. ft. ($12,667 \text{ m}^2$). Assuming an average size of 860 sq. ft. (72 m^2) netto for a two-bedroom apartment, the tissue models should contain from 120 to 175 units.

In both models, the B-zone is relatively shallow which decreases the floor area in relation to the deep Victorian buildings. It is obvious that in regard to available floor area, Tissue Model I_A is less attractive for residential use than Tissue Model IV_{C2a}. The shifting space for set-backs is reduced to 11' (3.30 m), excluding the bay window area. The deeper B-zone requires deeper floor plans which generate higher density.

The design examples of townhouses and sub-variations of Support System A will later be used to visualize the morphological framework of a tissue model-based design and to help in further investigations of density.

Tissue Model IV_{C2a} may be quantified as follows:

A. Coverage

Block frame	interior	B-zone	35,760 sq. ft.	(3,218 m ²)
	interior (50%)*	ob-margins	10,664 sq. ft.	(960 m ²)
	corner	B-zone	11,342 sq. ft.	(1,021 m ²)
	corner (50%)*	ob-margins	2,000 sq. ft.	(180 m ²)
Inner block		B-zone	5,400 sq. ft.	(486 m ²)
		ob-margins (50%)*	1,920 sq. ft.	(173 m ²)
TOTAL COVERAGE			67,086 sq. ft.	(6,038 m ²)
			(57.7% of block space, 422'6" x 275')	
O ₂ - and O ₃ -area			49,102 sq. ft.	(4,419 m ²)
			(42.3% of block space, 422'6" x 275')	

* This density study assumes that 50% of the ob-margins will be built.

B. Density Alternatives

I. Interior street location (2 main floors + roof story)	128,608 sq. ft. (11,575 m ²)
Corner street location (3 main floors + roof story)	51,368 sq. ft. (4,623 m ²)
Inner block location (2 main floors + roof story)	20,040 sq. ft. (1,804 m ²)
<hr/>	
TOTAL FLOOR AREA	200,016 sq. ft. (18,002 m ²)
FAR (in relation to block size 422'6" x 275' = 116,187.5 sq. ft. [126.75 m x 82.5 m = 10,456.8 m ²])	1.72
80% of total floor area*	160,013 sq. ft. (14,401 m ²)
FAR (considering 80% of total floor area)	1.37
II. Interior street location (3 main floors + roof story)	175,032 sq. ft. (15,753 m ²)
Corner street location (4 main floors + roof story)	64,710 sq. ft. (5,824 m ²)
Inner block location (2 main floors + roof story)	20,040 sq. ft. (1,304 m ²)
<hr/>	
TOTAL FLOOR AREA	259,782 sq. ft. (23,381 m ²)
FAR (in relation to block size 422'6" x 275' = 116,187.5 sq. ft. [126.75 m x 82.5 m = 10,456.8 m ²])	2.23
80% of floor area*	207,825 sq. ft. (18,704 m ²)
FAR (considering 80% of total floor area)	1.78

* The zoning distribution perpendicular to the street decreases building coverage of the B-zone and ob-margins by an average of 20%.

According to the density calculation, the netto floor area for Tissue Model IV_{C2a} ranges between 128,010 sq. ft. (11,520.9 m²) and 166,260 sq. ft. (14,963.3 m²). Therefore, this tissue model contains a minimum of 160 and a maximum of 207 units, with an average netto floor area of 800 sq. ft. (72 m²). The FAR ranges from 1.37 to 1.78.

Application of this tissue model is not bound to a specific uniform floor height for the entire block area. Certain agreements are necessary to adapt new built elements to the existing built situation and fulfill functions which lie beyond the scope of an average 800 sq. ft. two-bedroom apartment.

The process of decision making is complex. Different groups participate on different levels during the development of a project. General regulations, as well as specific decisions, must be assimilated in the planning process. To help make this procedure transparent for all who are involved and to arrange problems and solutions in a hierarchy of decision levels, SAR 73 uses a notation system. This system is summarized in section 2.25. The method was used for the analysis of Block 1155 (section 2.3). The following eighteen figures, Figure 125 to 142, demonstrate schematically the refinement of the decision-making process for the application of Tissue Model IV_{C2a} in a design simulation.

According to the rules for notating agreements, a set of documents reflecting agreements on positions, dimensions, and functions of thematic and non-thematic buildings and spaces in a given area must constitute a tissue model. Moreover, the tissue model must contain various explanations of the agreements which were presented in the general tissue rules (section 3.42).

The following documents define Tissue Model IV_{C2a}:

Fig. 125	Document 1+2	Agreement Sheet 1	System of zoning agreements with respect to the morphology of the thematic elements (basis for all subsequent documents).
Fig. 126	Document 1	Explanation Sheet 1	Explanation with respect to the morphology of the thematic building (maximum and minimum dimensions of built elements).
Fig. 127	Document 1	Explanation Sheet 2	Explanation with respect to the morphology of the thematic building (interior street location for Support System B).
Fig. 128	Document 1	Explanation Sheet 3	Explanation with respect to the morphology of the thematic building (corner street location for Support System B).
Fig. 129	Document 1	Explanation Sheet 4	Explanation with respect to the morphology of the thematic building (maximum and minimum dimensions of Support System A).
Fig. 130	Document 1	Explanation Sheet 5	Explanation with respect to the morphology of the thematic building (maximum and minimum set-back depths for street location).
Fig. 131	Document 2	Explanation Sheet	
Fig. 131	Document 2	Explanation Sheet 1	Explanation with respect to the morphology of the thematic space (minimum and maximum dimensions of O ₂ - and O ₃ -zones).
Fig. 132	Document 2	Explanation Sheet 2	Explanation with respect to the morphology of the thematic space (parallel and perpendicular zoning systems).

Fig. 133	Document 3	Agreement Sheet 1	Agreements with respect to the morphology of the non-thematic building (location of non-thematic buildings).
Fig. 134	Document 4	Agreement Sheet 1	Agreements with respect to the morphology of the non-thematic space (dimensions and locations of O-zones and ob-margins perpendicular to the street).
Fig. 135	Document 5a	Agreement Sheet 1	Agreements on position with respect to functions of the thematic building (location of non-residential functions).
Fig. 136	Document 5b	Agreement Sheet 1	Agreements on dimensions with respect to functions of the thematic building (dimensions of dwellings).
Fig. 137	Document 6a	Agreement Sheet 1	Agreements on position with respect to functions of the thematic space (circulation elements, additional parking, etc).
Fig. 138	Document 6b	Agreement Sheet 1	Agreements on dimensions with respect to functions of the thematic space (private open spaces, public open spaces, etc.).
Fig. 139	Document 7a	Agreement Sheet 1	Agreements on position with respect to functions of the non-thematic building (extension of non-thematic buildings into O ₃ -zones)
Fig. 140	Document 7b	Agreement Sheet 1	Agreements on dimensions with respect to functions of the non-thematic building (location of path to public green in public building).
Fig. 141	Document 8a	Agreement Sheet 1	Agreements on position with respect to functions of the non-thematic space (public green area, parking, playgrounds in B-zones).
Fig. 142	Document 8b	Agreement Sheet 1	Agreements on dimensions with respect to functions of the non-thematic space (dimensions of forecourts, parking, etc).

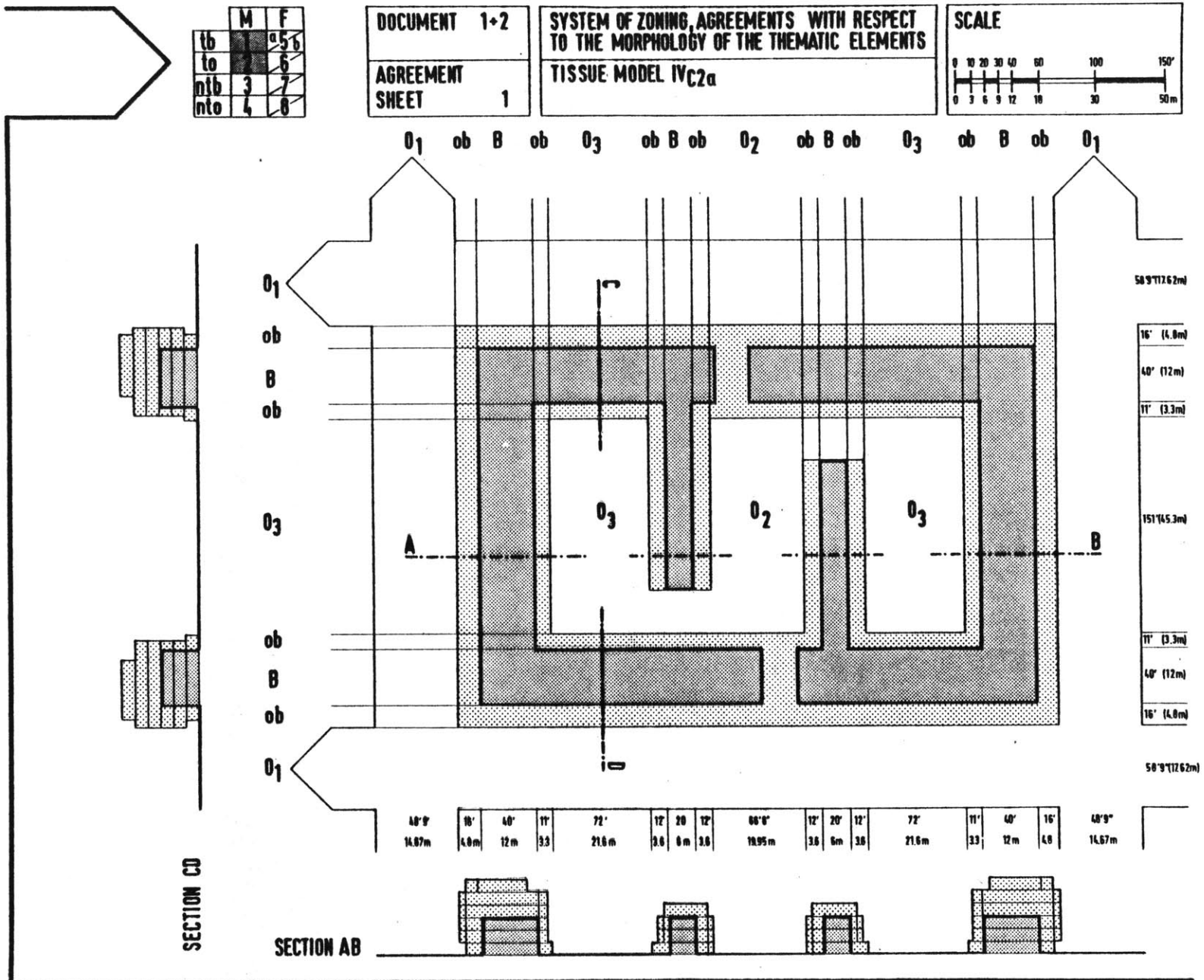

Fig. 125

	M	F
tb	1	5
to	2	6
ntb	3	7
nto	4	8

DOCUMENT	1
EXPLANATION SHEET	1

EXPLANATION WITH RESPECT TO THE MORPHOLOGY OF THE THEMATIC BUILDING

SUPPORT SYSTEM A AND B
EXTENSIONS OF BAYWINDOWS AND BASES EXCLUDED

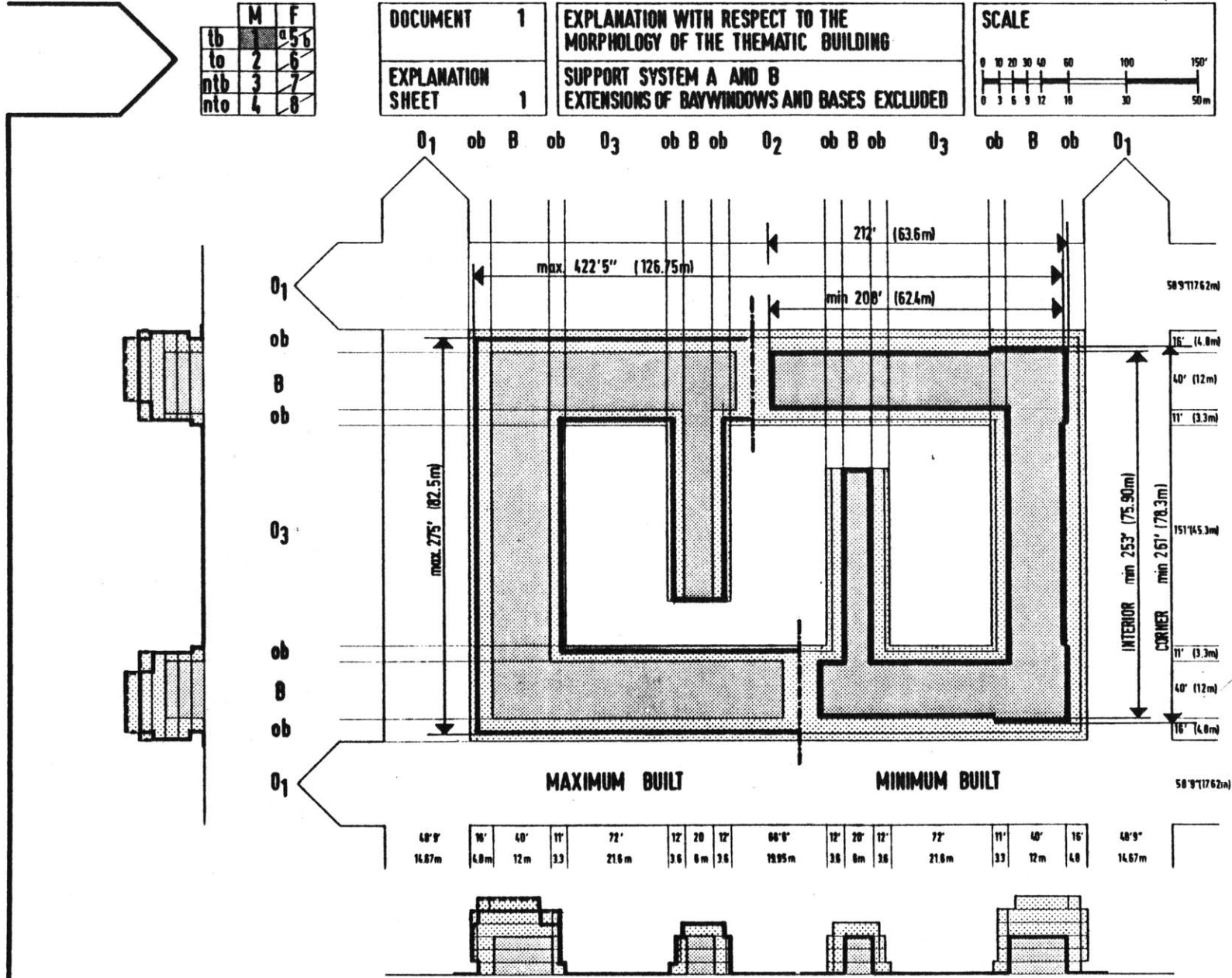
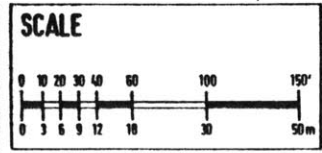

Fig. 126

	M	F
tb	1	5
to	2	6
ntb	3	7
nto	4	8

DOCUMENT	1
EXPLANATION SHEET	2

EXPLANATION WITH RESPECT TO THE MORPHOLOGY OF THE THEMATIC BUILDING

INTERIOR LOCATION SUPPORT SYSTEM B
EXTENSIONS OF BAYWINDOWS & BASE EXCLUDED

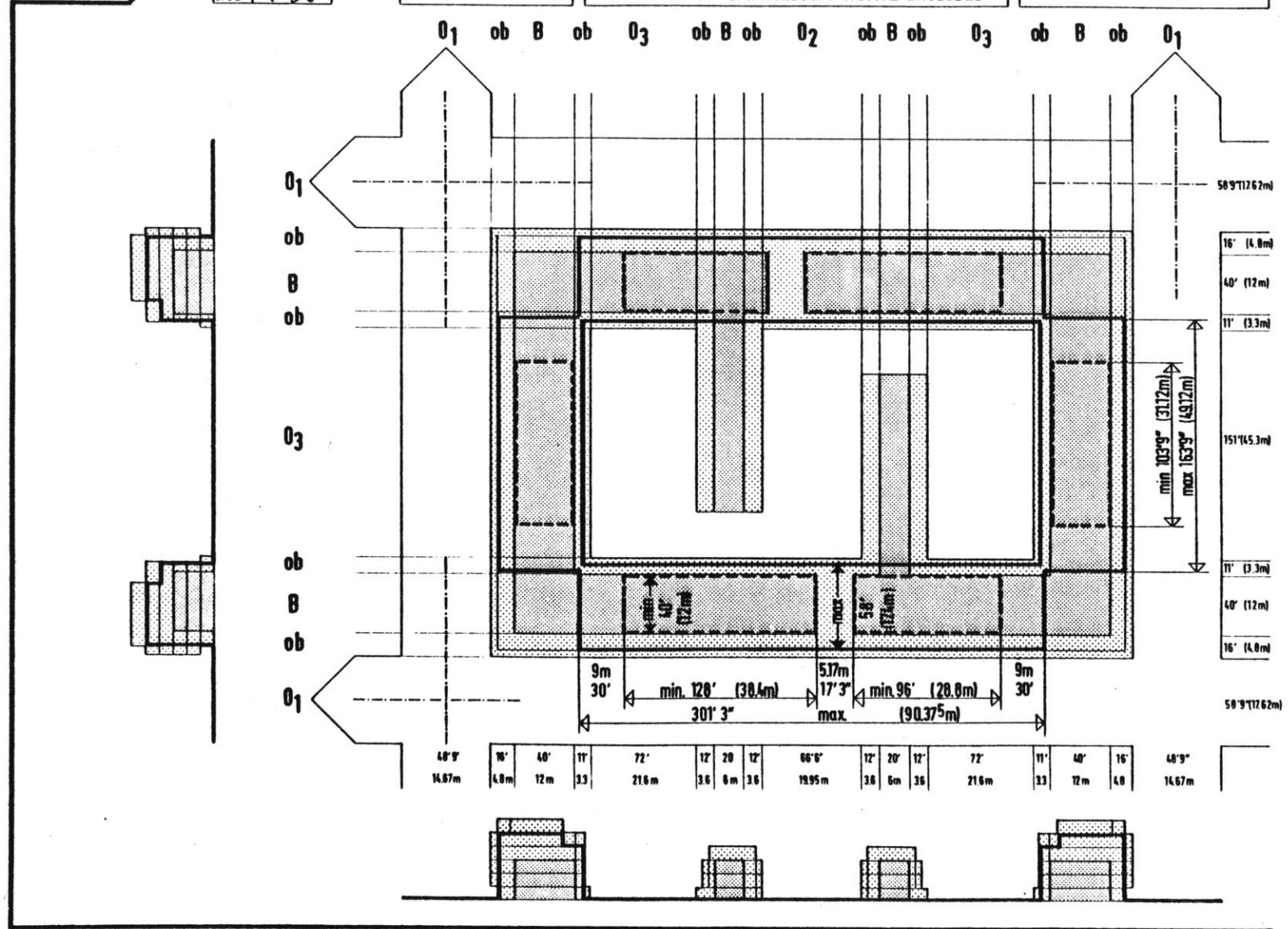
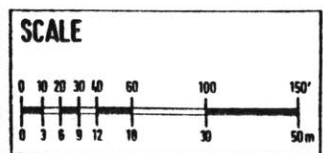

Fig. 127

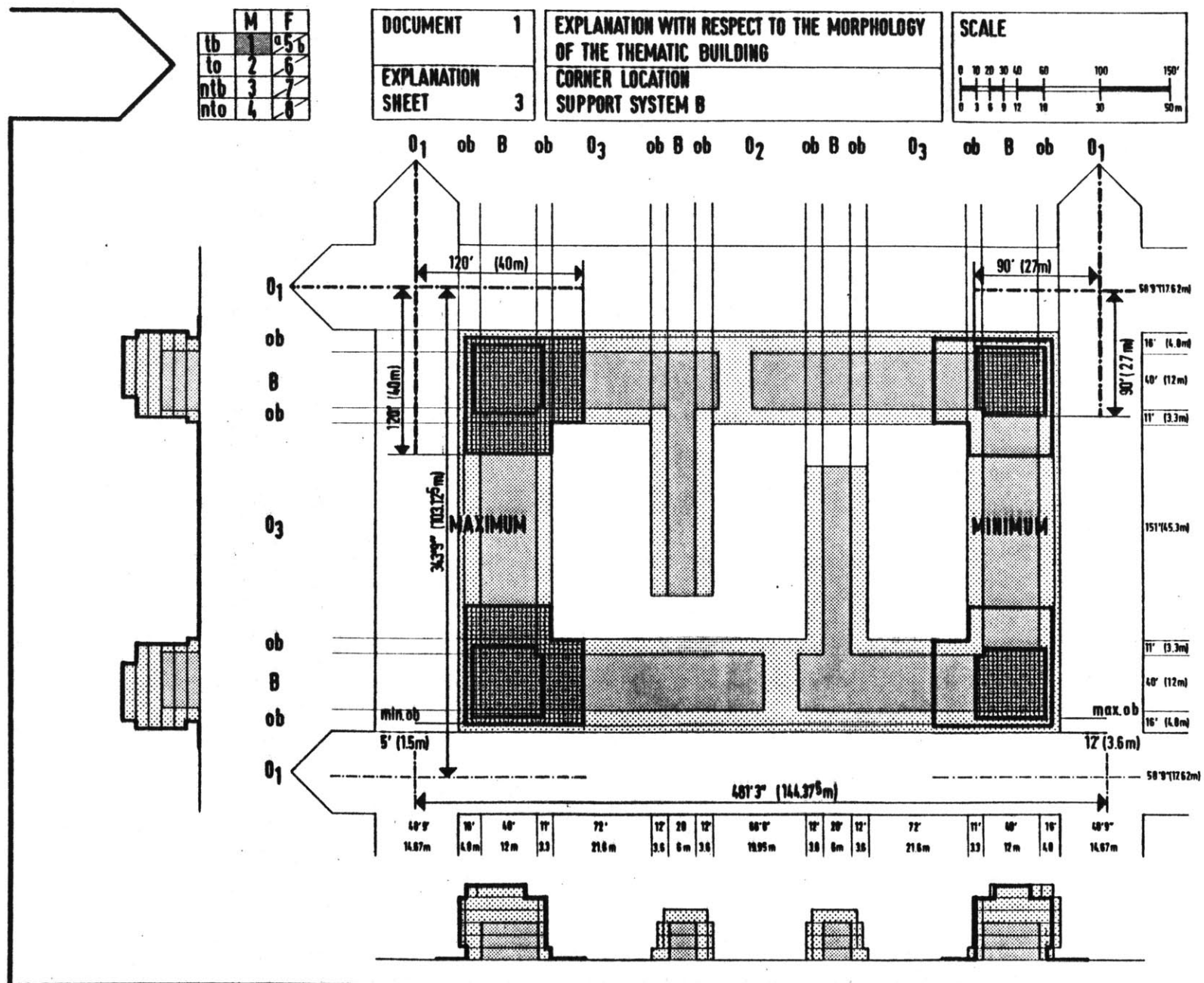

Fig. 128

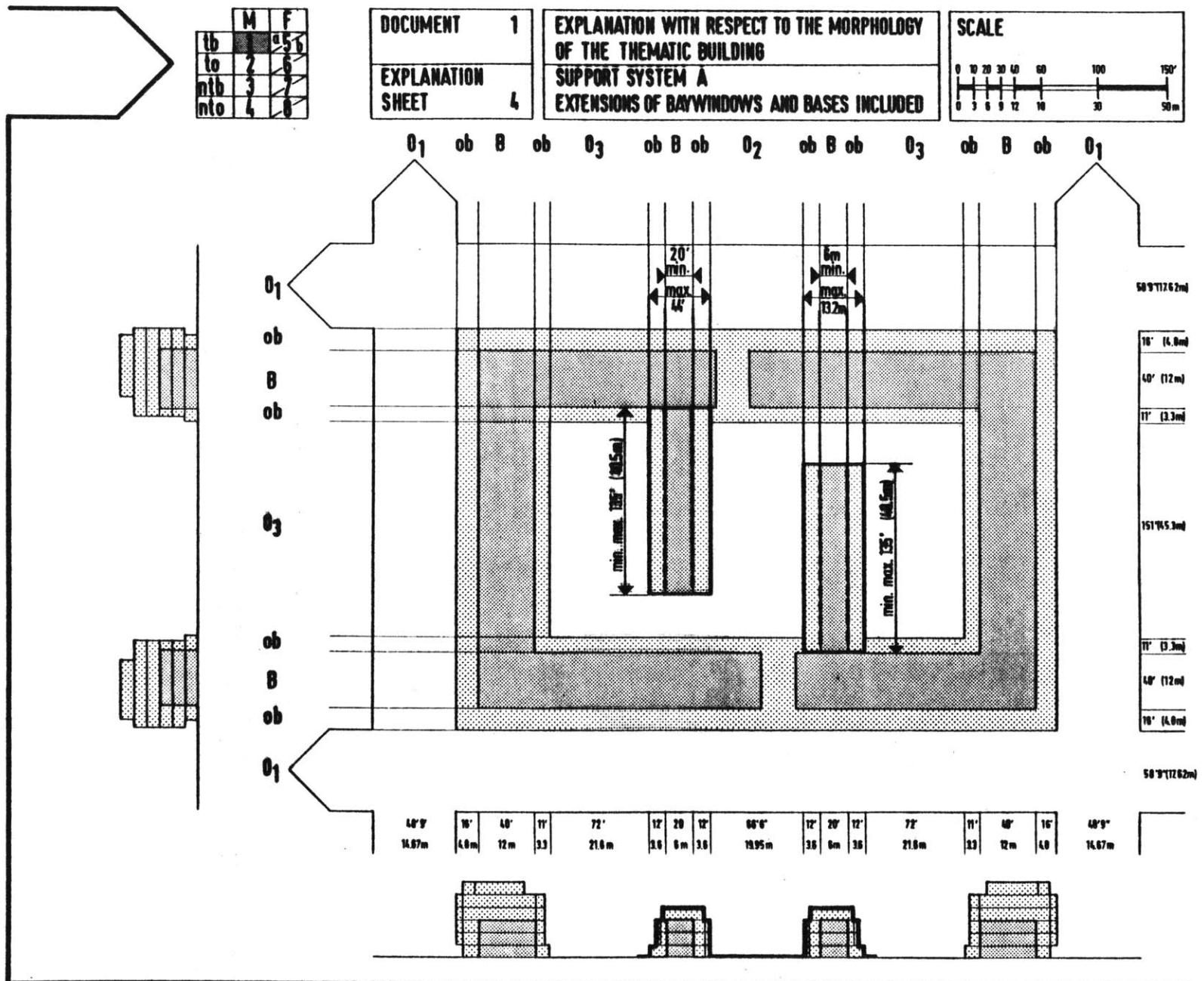

Fig. 129

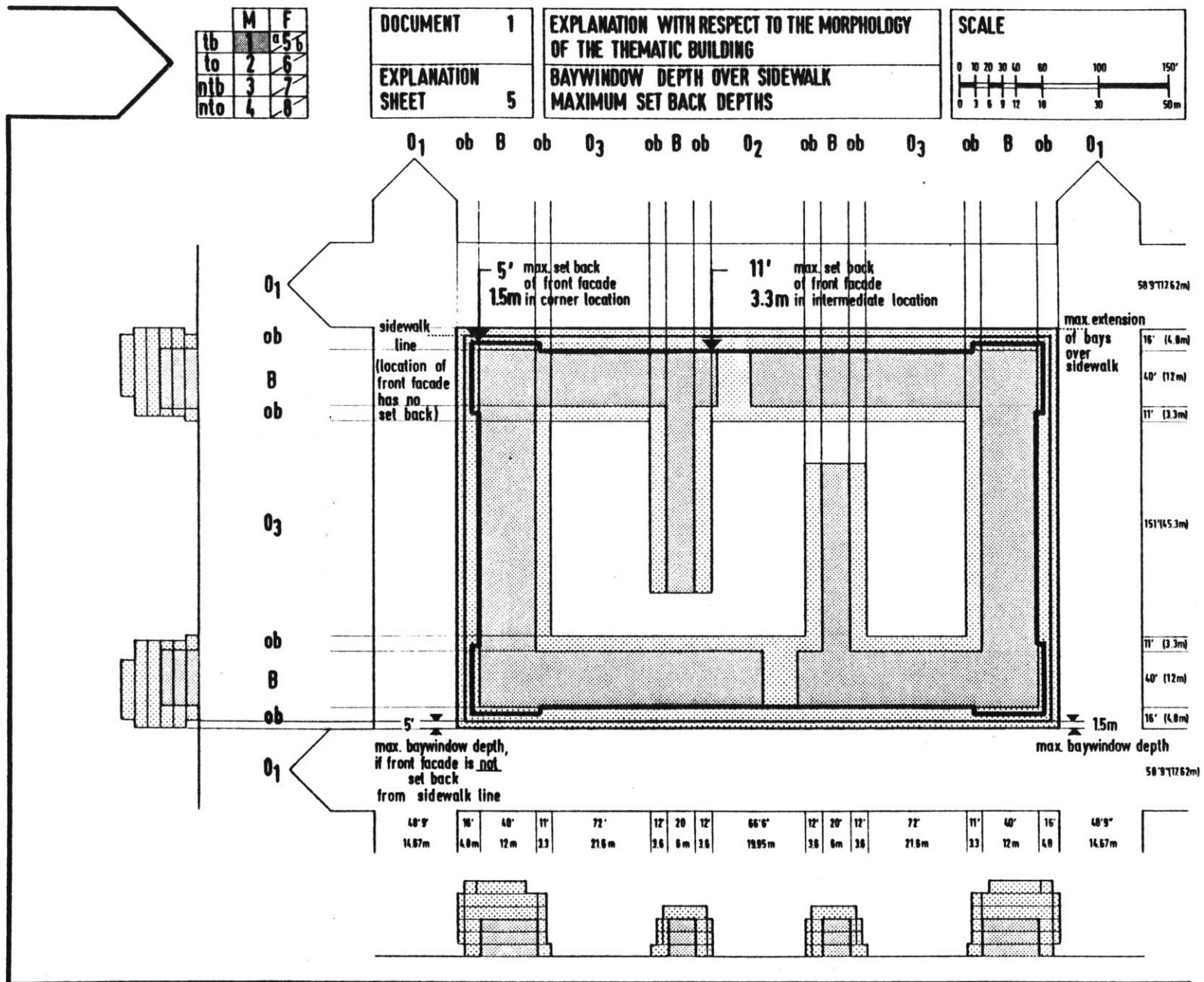

Fig. 130

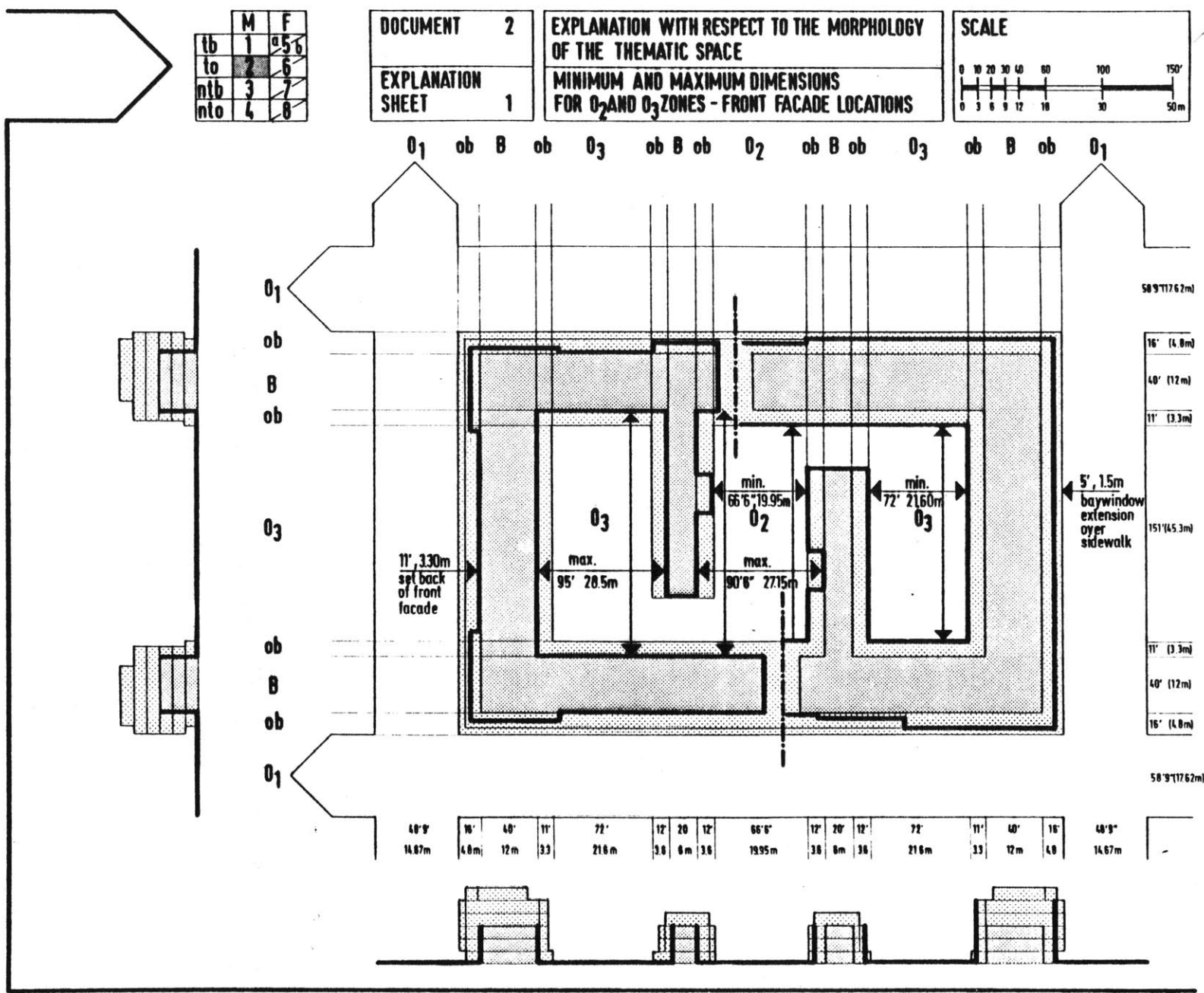
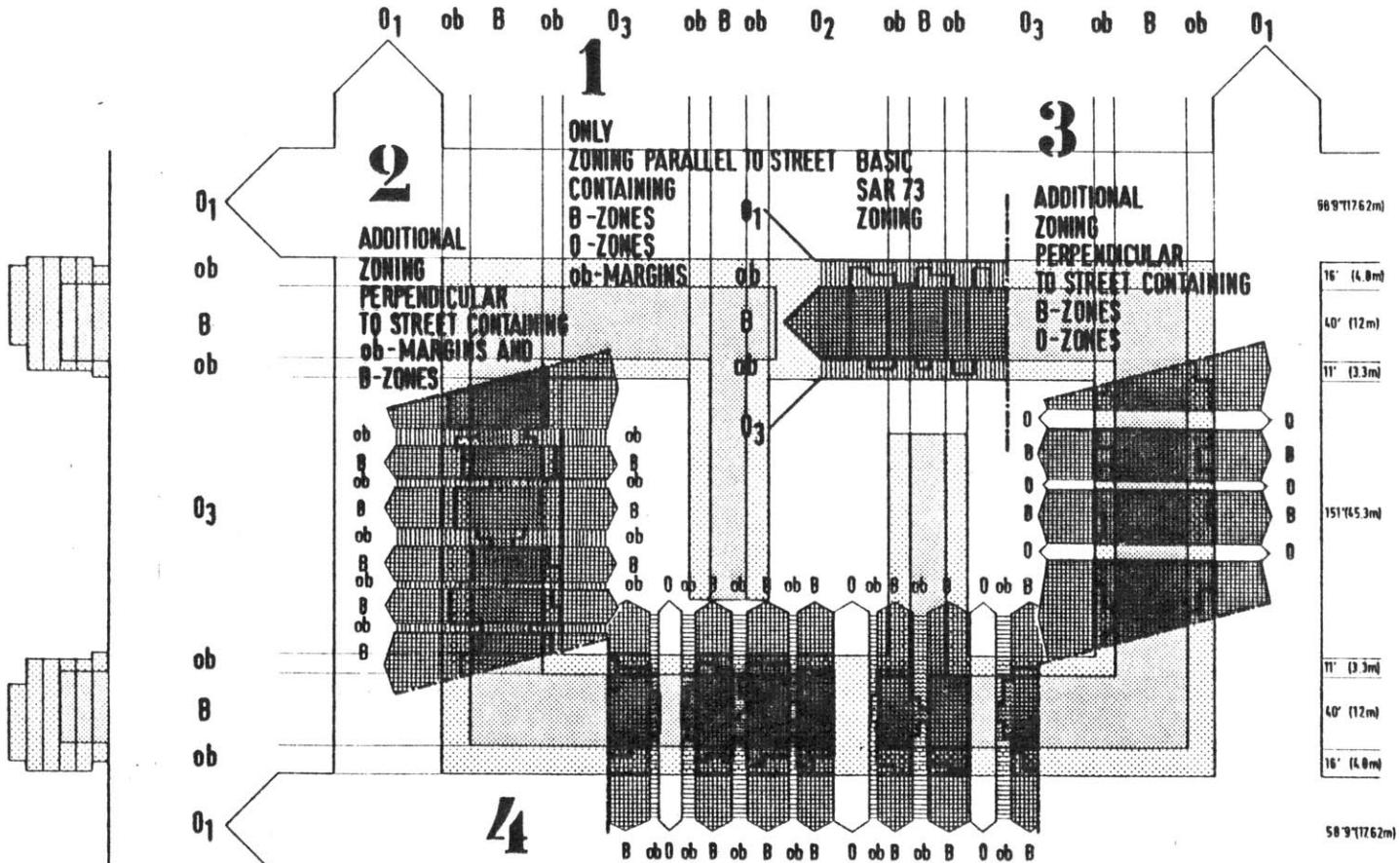
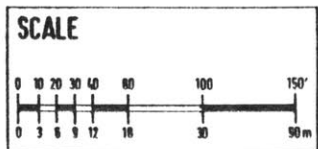

Fig. 131

	M	F
tb	1	a5b
to	2	6
nib	3	7
nto	4	8

DOCUMENT 2
EXPLANATION SHEET 2

EXPLANATION WITH RESPECT TO THE MORPHOLOGY OF THE THEMATIC SPACE
ZONING SYSTEMS OF THE TISSUE MODEL



BECAUSE OF THE POSSIBLE INDIVIDUAL ARRANGEMENT OF ZONING SYSTEMS $\alpha, \beta, \gamma, \delta$ FOR EACH STREET ELEVATION, FURTHER, MORE SPECIFIC AGREEMENTS ARE NOTATED IN DOCUMENT 4.

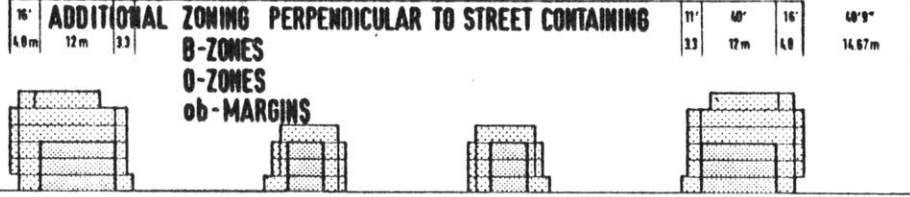

Fig. 132

	M	F
tb	1	5
to	2	6
ntb	3	7
nto	4	8

DOCUMENT	3
AGREEMENT SHEET	1

AGREEMENTS WITH RESPECT TO THE MORPHOLOGY OF THE NON THEMATIC BUILDING

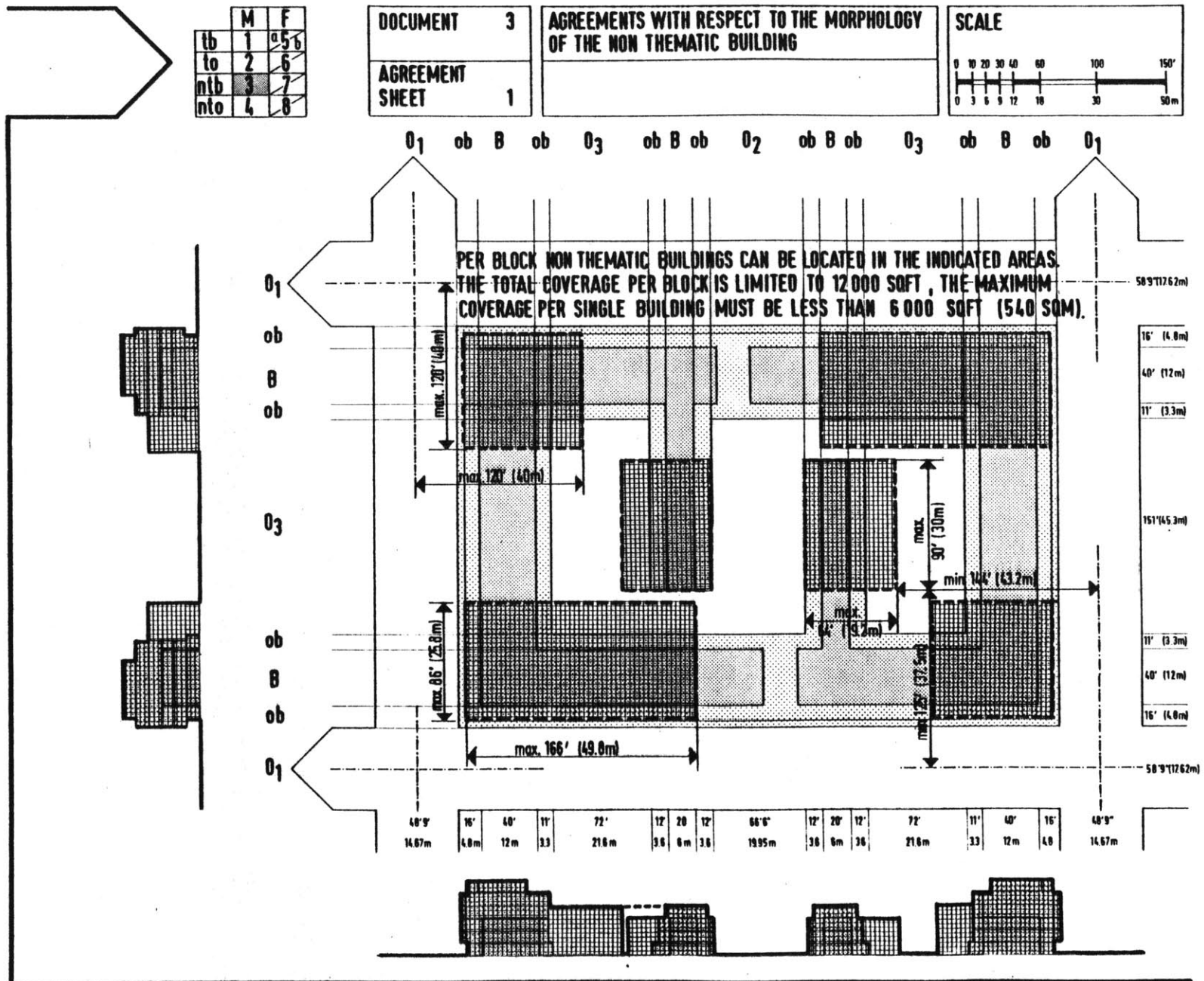
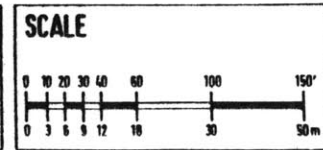

Fig. 133

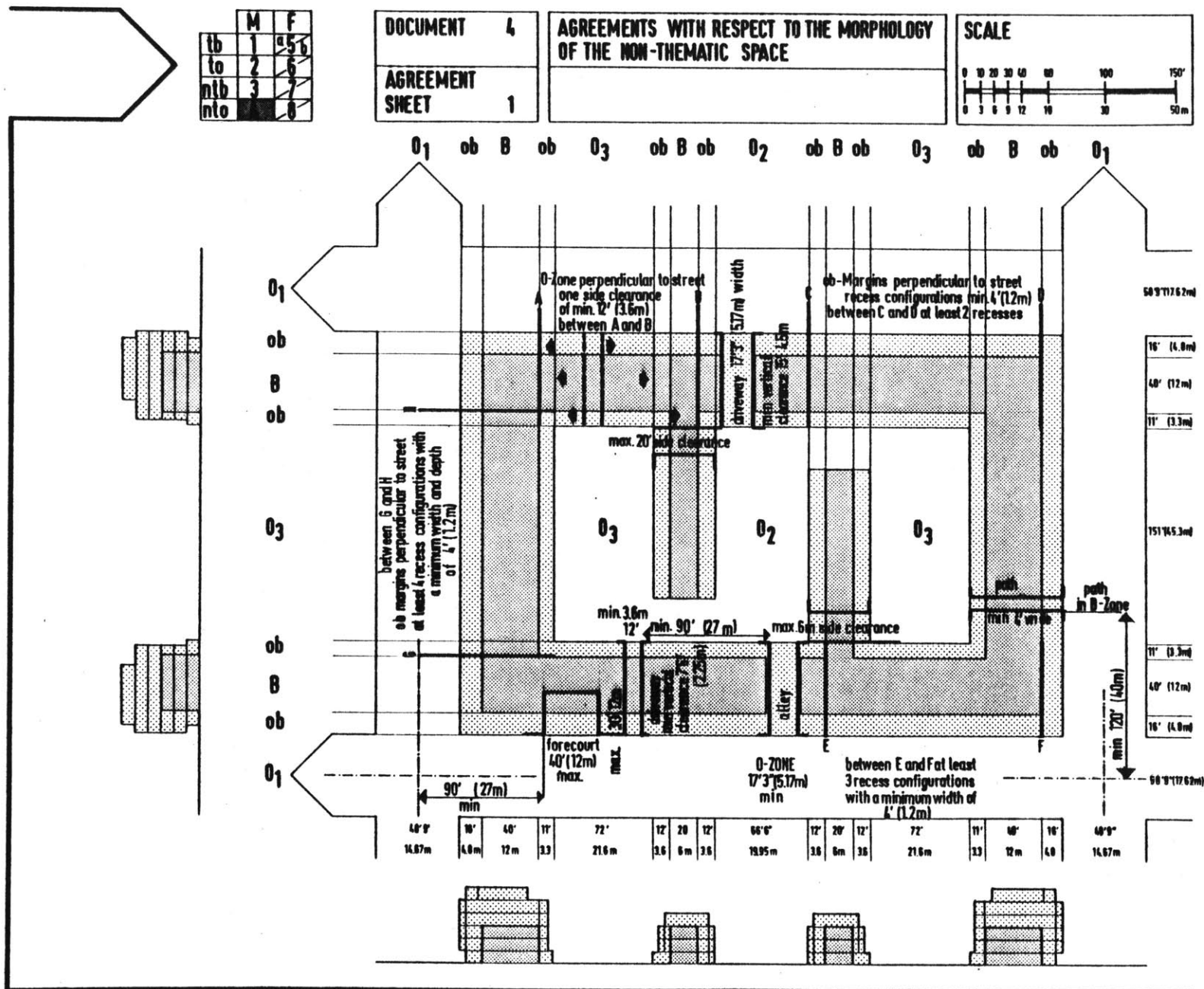

Fig. 134

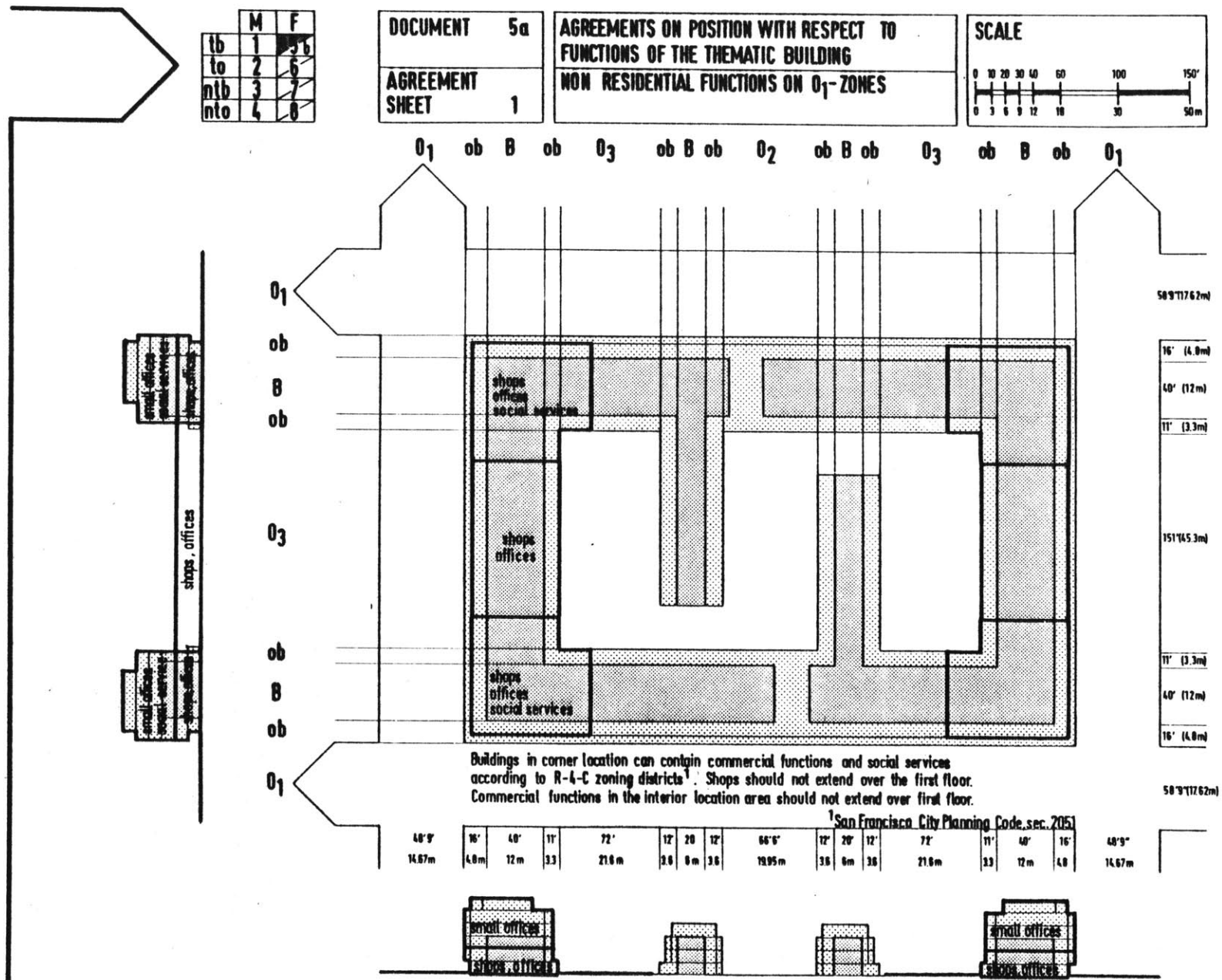

Fig. 135

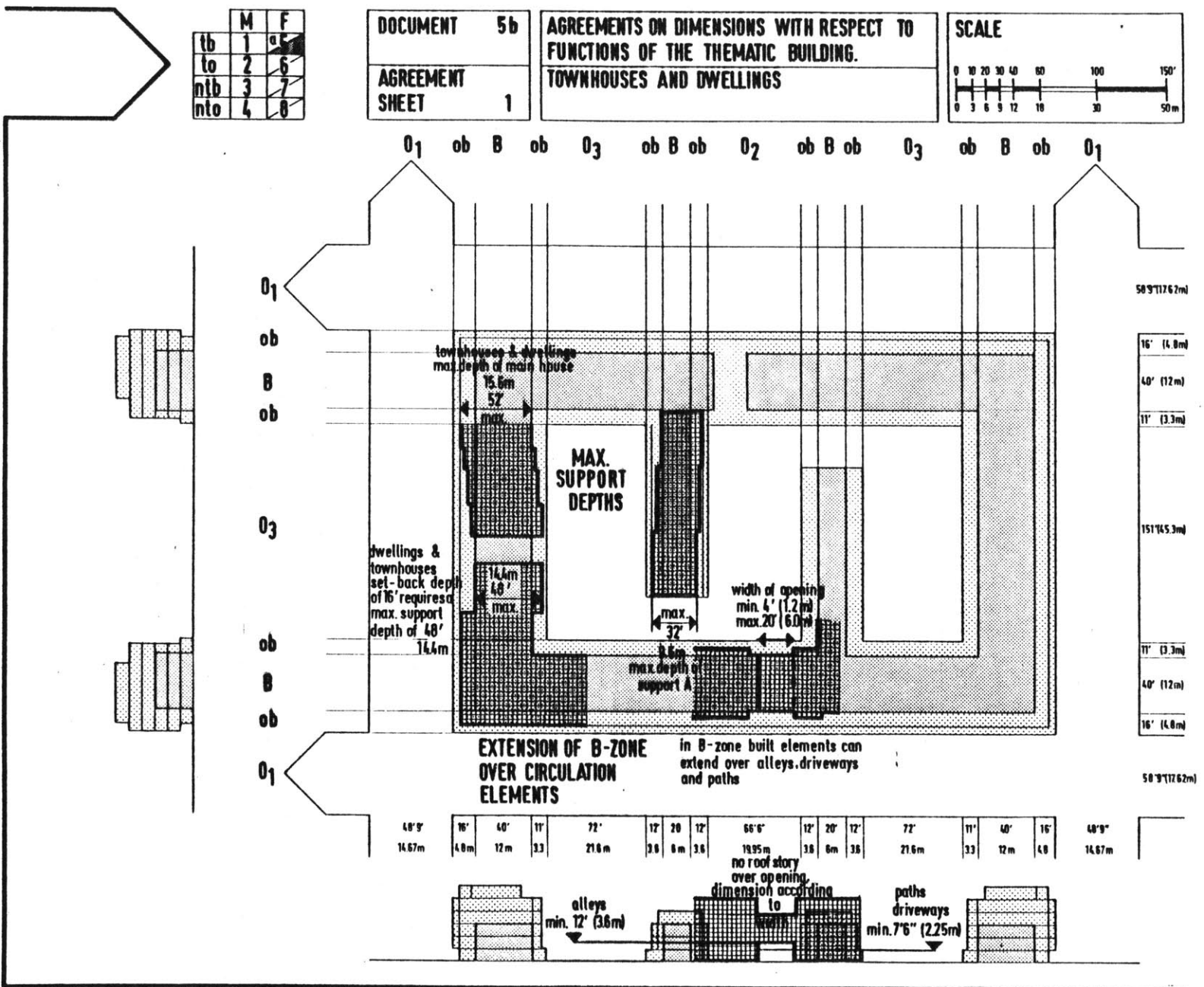

Fig. 136

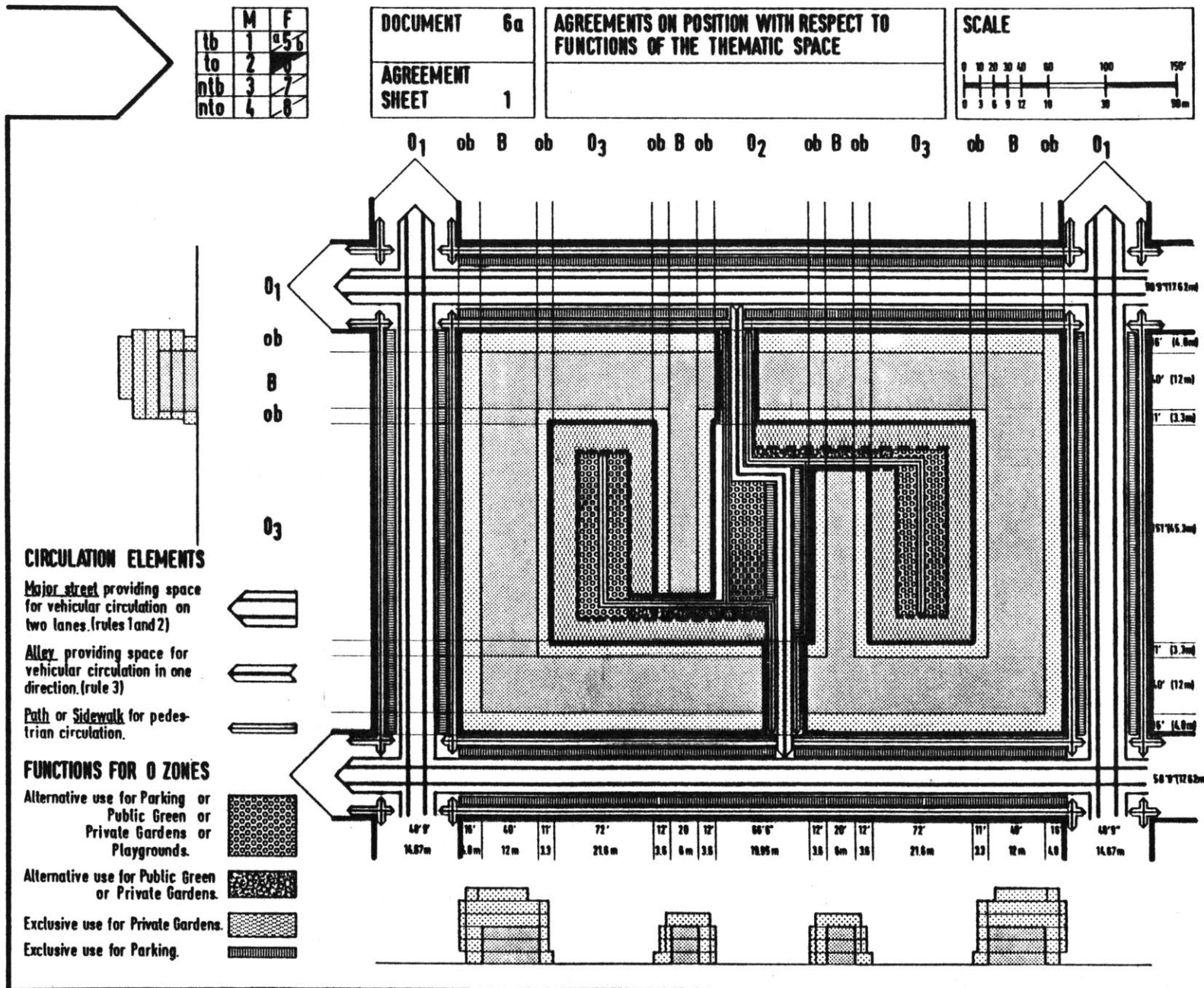

Fig. 137

	M	F
tb	1	5
to	2	6
ntb	3	7
nto	4	8

DOCUMENT	6b
AGREEMENT SHEET	1

AGREEMENTS ON DIMENSIONS WITH RESPECT TO FUNCTIONS OF THE THEMATIC SPACE

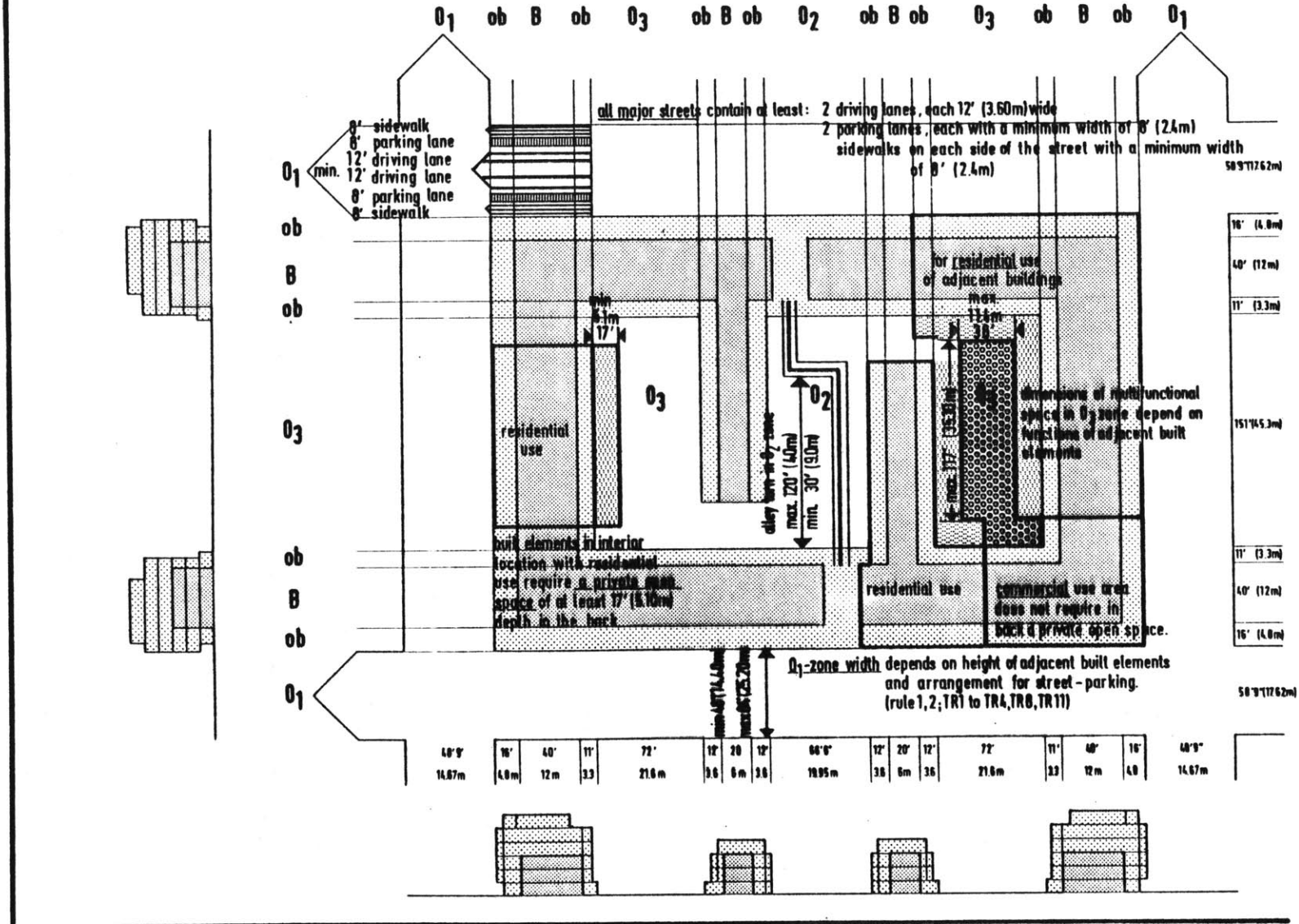
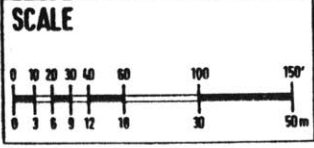

Fig. 138

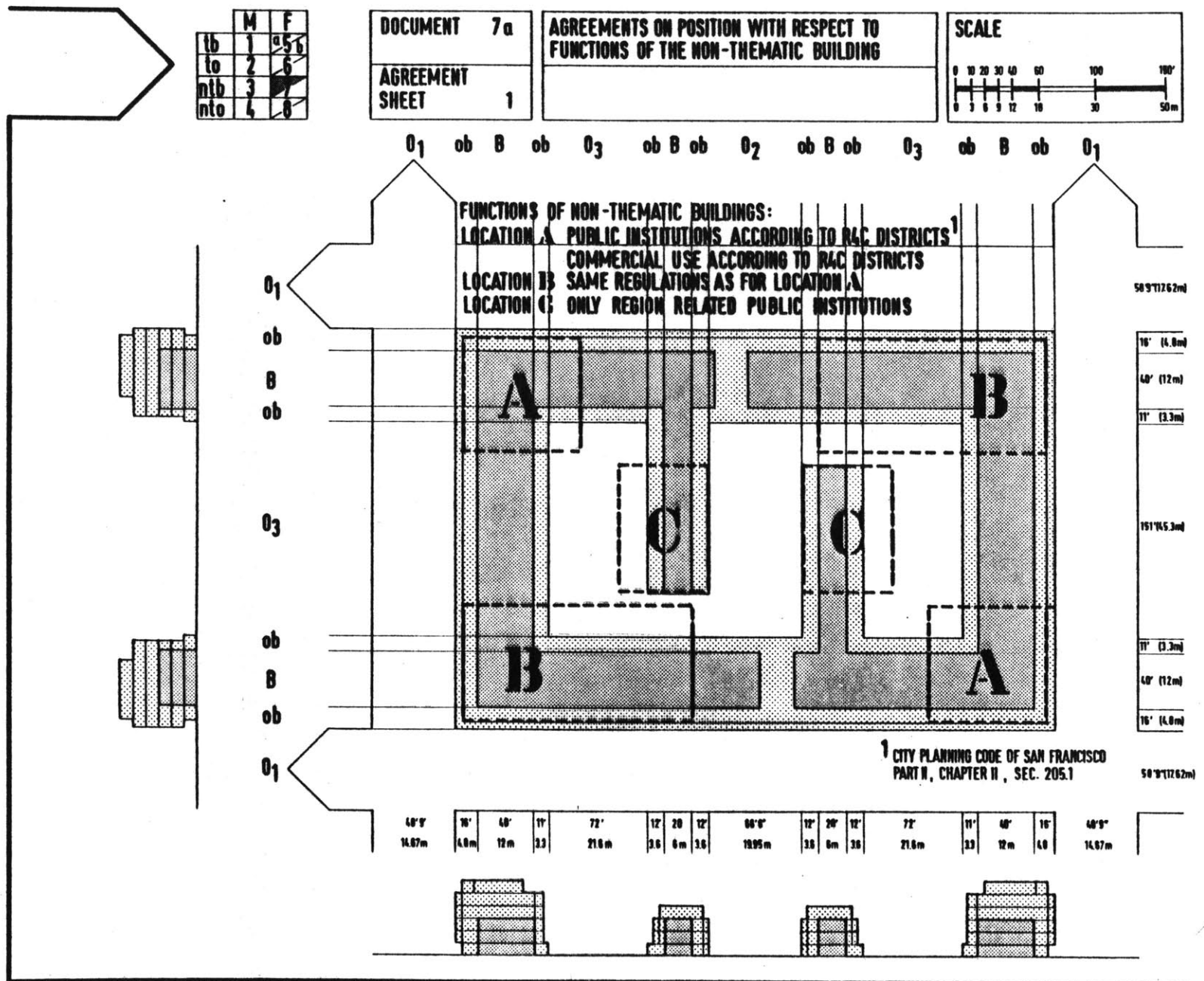

Fig. 139

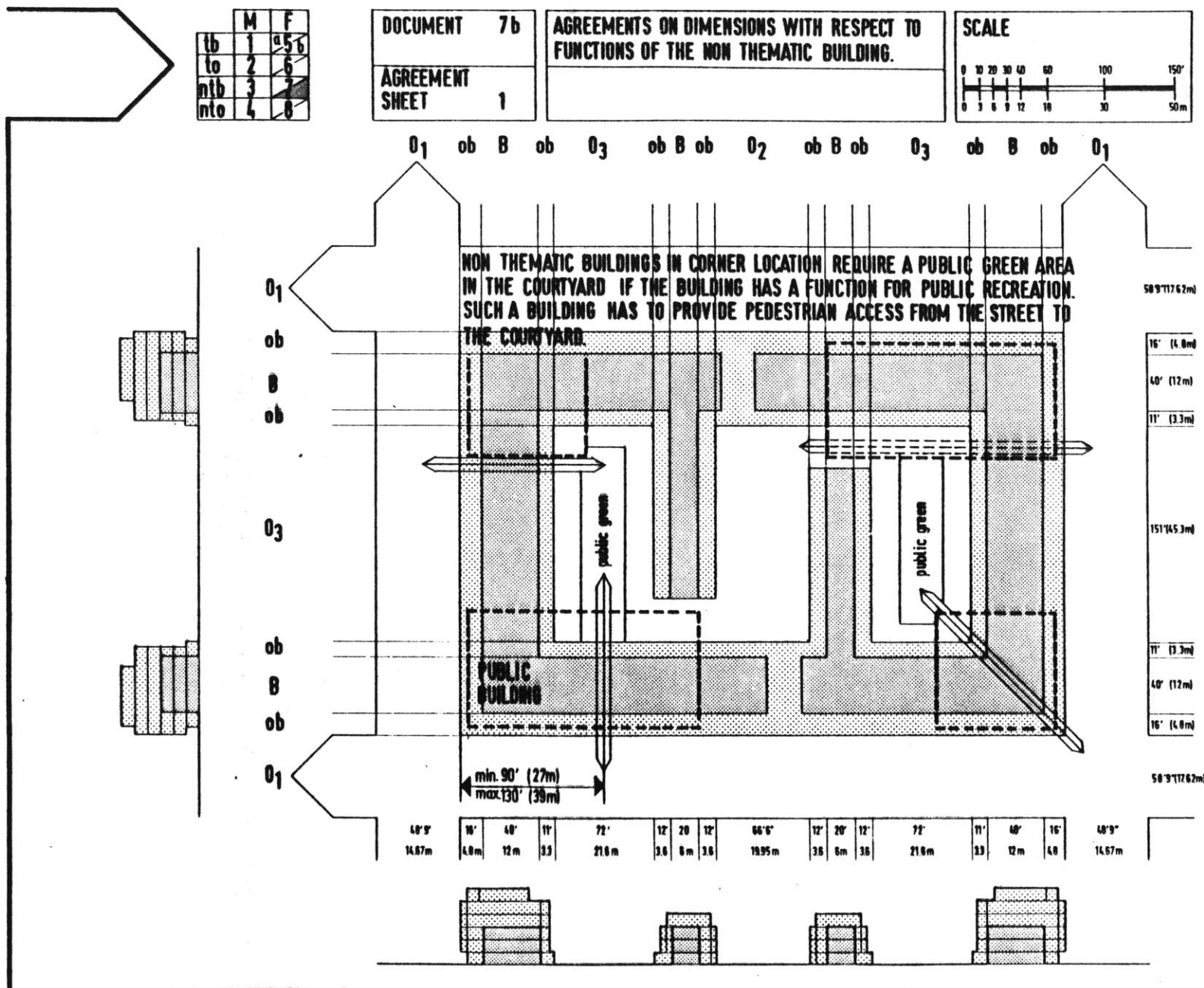

Fig. 140

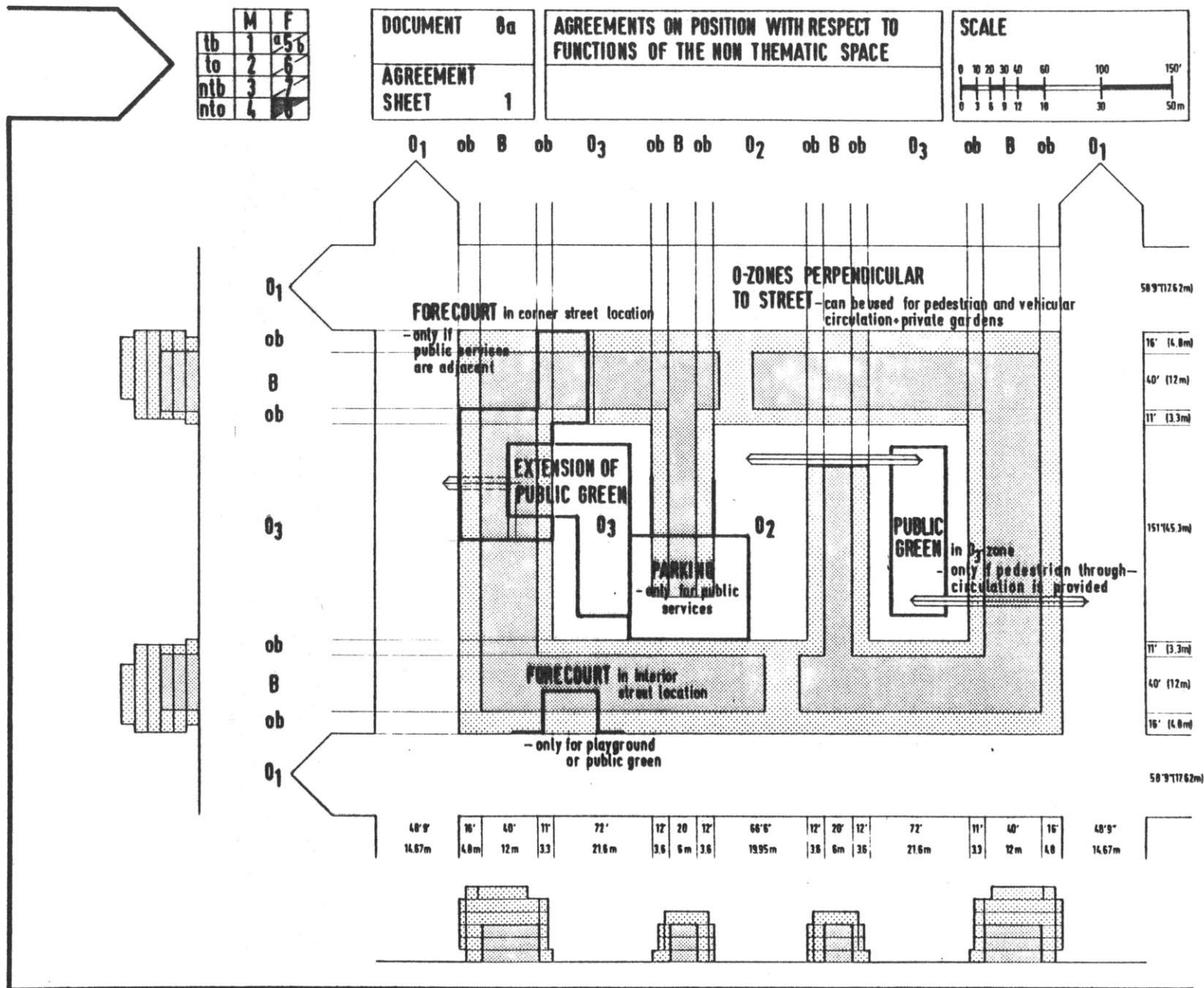

Fig. 141

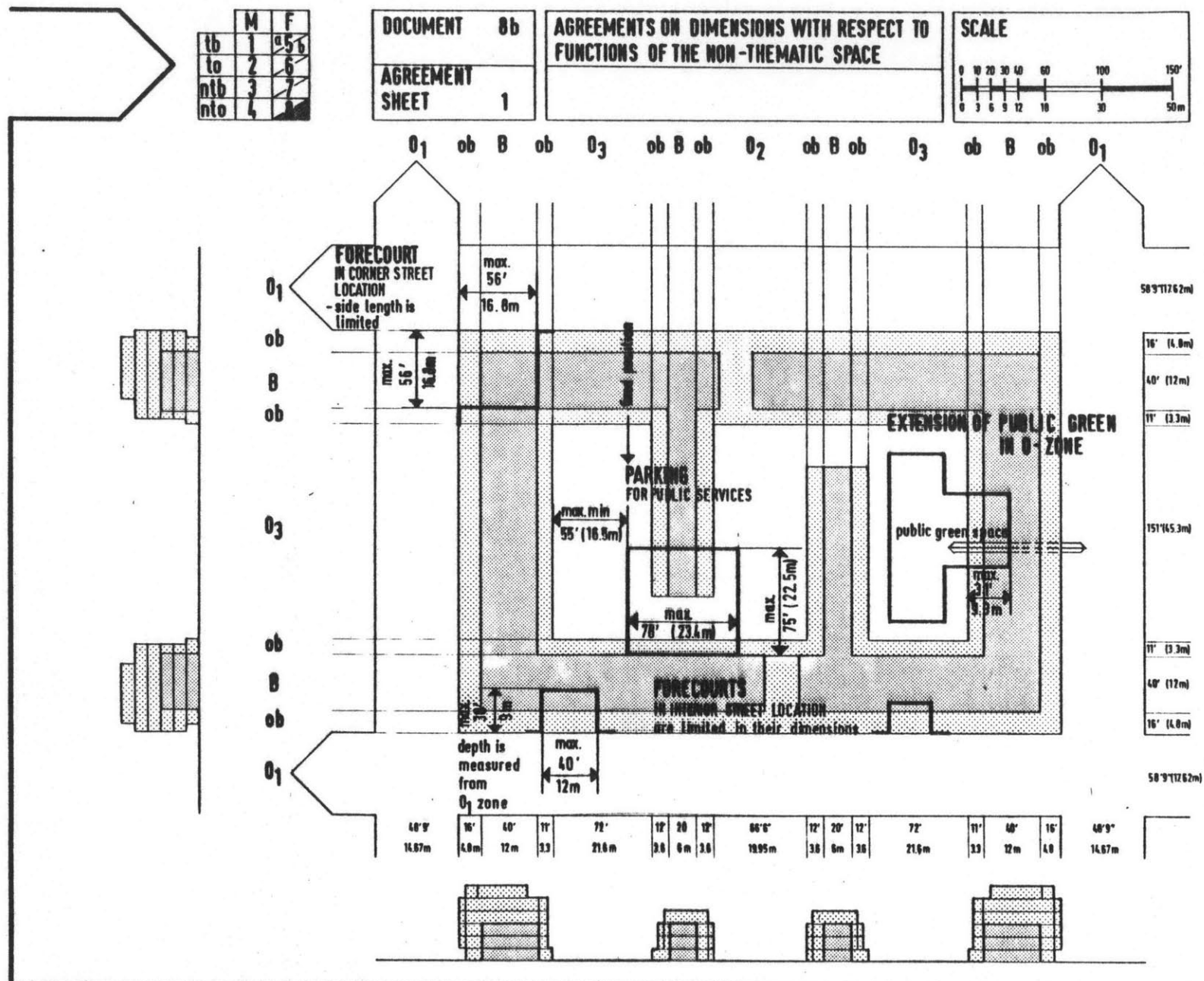

Fig. 142

3.5

APPLICATION OF BUILDING TYPES IN TISSUE MODEL IV_{C2a}

The following example presents a fictitious design of a residential block. Fulfilling the requirements of Tissue Model IV_{C2a}, this design applies building types of Support Systems A and B, exclusively, to interior street locations and inner block locations. The design assumes a topographical situation with an eight per cent slope. The inner block area is characterized by two O₃-zones and one O₂-zone which are directed parallel to the slope. One O₃-zone is used for additional parking, the other contains public green.

Buildings which also have non-residential functions are located at three of the corners of this block. The frame of the built zone around the block is opened for two alleys, two driveways, and paths for pedestrian circulation. A passage is also provided through one corner building, giving pedestrian access to the public green space.

Figure 143 indicates the distribution of house types in the tissue model. Their exact location and the morphology of the design is presented in the site plan (Fig. 144). This simulation applies, for Support System A, the 1/2 module 1 three times, the 1/2 module 2 one time, the 1/2 module 3 two times, which generates fourteen units in the inner block.

For the interior street location, Type 1 is applied ten times, Types 2 and 3 nine times each, and Type 4 is used eight times. The corner buildings contain a total of thirty-six apartments.

Residential capacity:

Buildings/sectors	Number of Sectors*	Number of Units	Total Floor Area	Netto Floor Area per Unit
Apartment buildings in street corner location	—	36	31,680 sq. ft. (2,851 m ²)	880 sq. ft. (79 m ²)
Apartment buildings in inner block	6	14	10,231 sq. ft. (920 m ²)	730 sq. ft. (66 m ²)
Townhouses in interior street interior street location	10	15	16,640 sq. ft. (1,497 m ²)	1,168 sq. ft. (105 m ²)
Type 1 (1 1/2 units per sector)**	10	15	16,640 sq. ft. (1,497 m ²)	1,168 sq. ft. (105 m ²)
Type 2 (2 units per sector)	9	18	19,152 sq. ft. (1,723 m ²)	1,064 sq. ft. (95 m ²)
Type 3 (2 1/2 units per sector)***	8	22.5	26,280 sq. ft. (2,365 m ²)	1,168 sq. ft. (105 m ²)
Type 4 (4 units per sector)	8	32	28,560 sq. ft. (2,570 m ²)	892 sq. ft. (80 m ²)
TOTAL	36	137.5	132,543 sq. ft. (11,929 m²)	964 sq. ft. (86 m²)

*Support System A + townhouse types

**The study assumes for 50% of Sector Type 1 an occupation of two units.

***This study assumes for 50% of Sector Type 3 and occupation of three units.

The total block area (including 50% of the surrounding O₁-zones) is 165,430 sq. ft. (14,888 m²), which is equal to 3.79 acres (1.7 hectares). The design presented has a density of 36.2 residential units per acre (80.8 units per hectare) and contains additional space for non-residential use of 19,666 sq. ft. (1,770 m²).

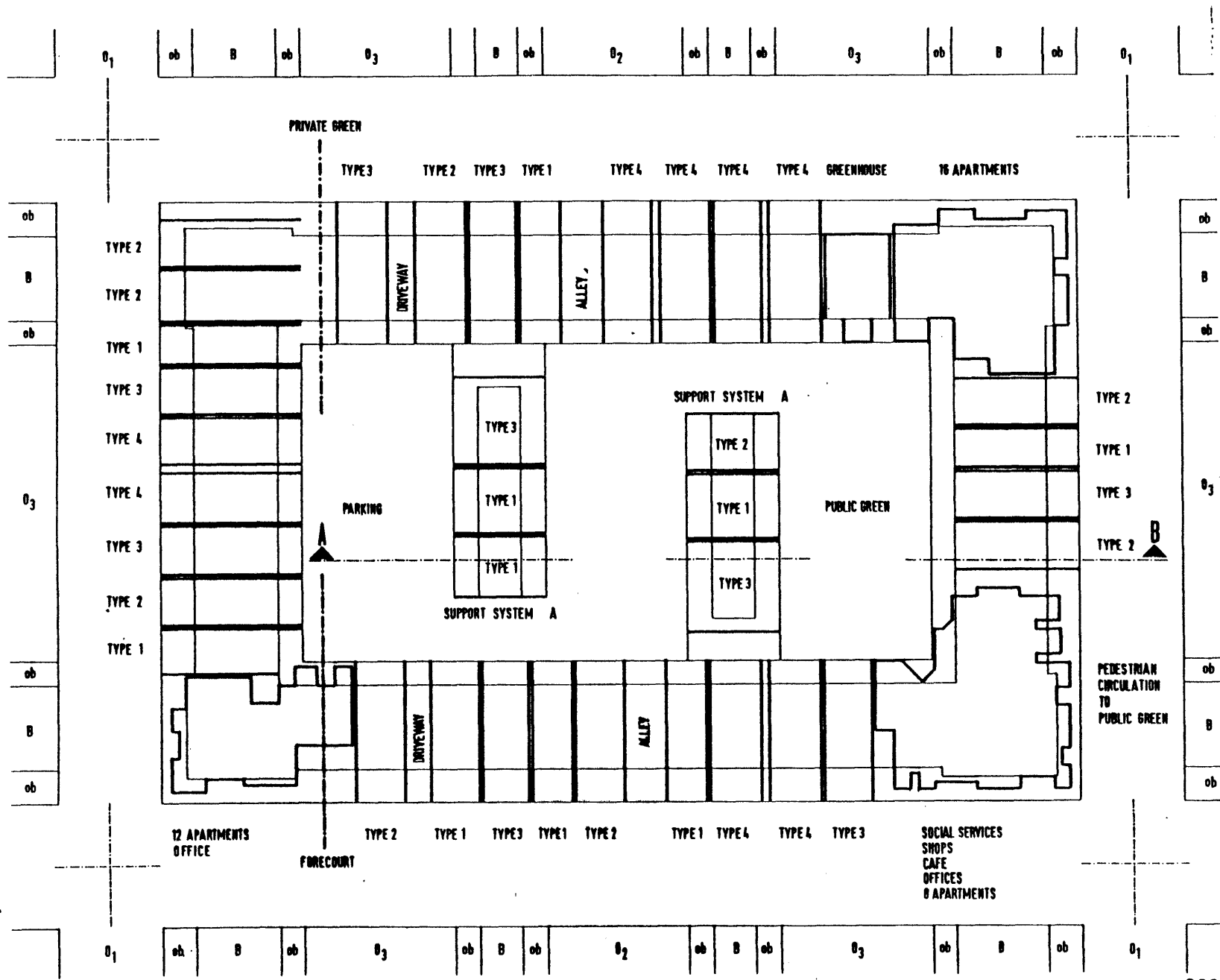

Fig. 143

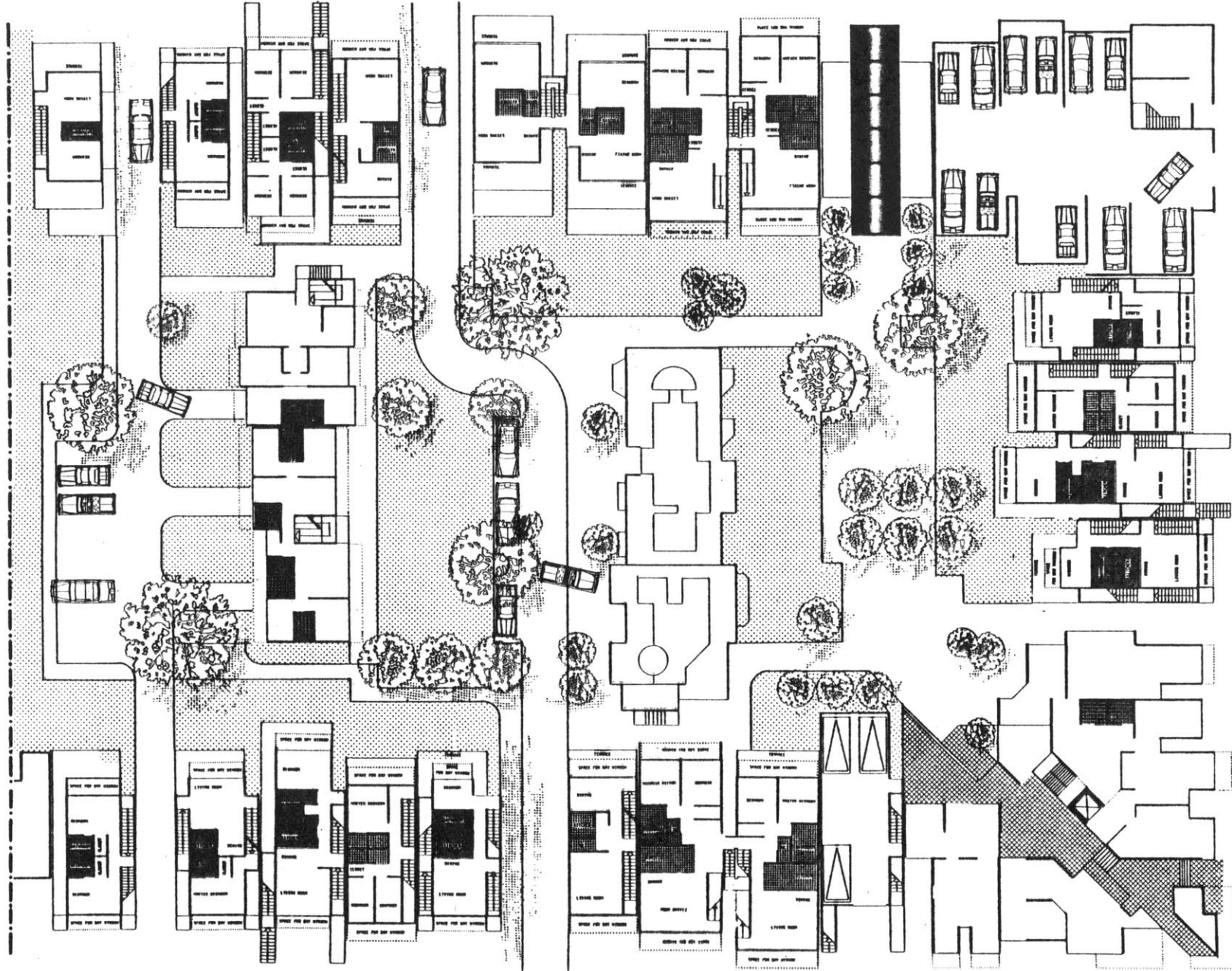
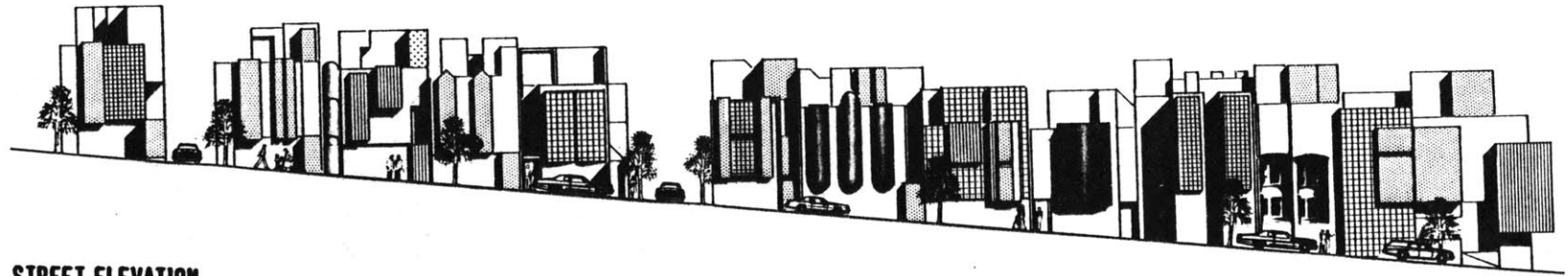

Fig. 144

Fig. 144 Street Elevation

Fig. 145 Section A B



STREET ELEVATION

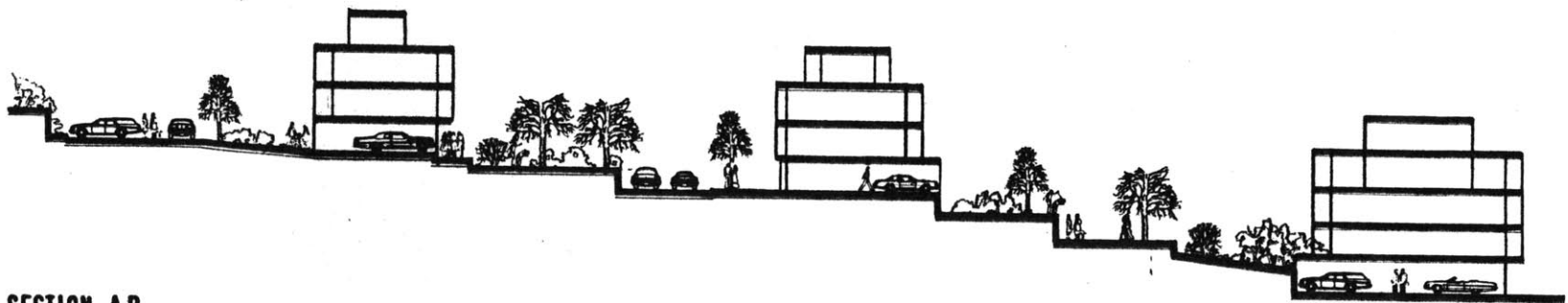

SECTION A B

Parking capacity. For all townhouse types of Support Systems A and B, sufficient parking space is provided. Necessary additional parking for apartments or commercial institutions can be located in the O_3 -zone as indicated in the site plan (Fig. 144).

The street elevation as shown in Figure 144 indicates the main principles of the sector arrangement, and the differentiation of morphological elements generated by the tissue rules. The drawing must be perceived as an abstraction of a possible facade texture. Blank surfaces in the main floor area indicate the facade of the main house. Bay windows of different sizes, shapes and ornamentation extend into the ob-margin. The different textures indicate the possible individuality in style, design, color and material.

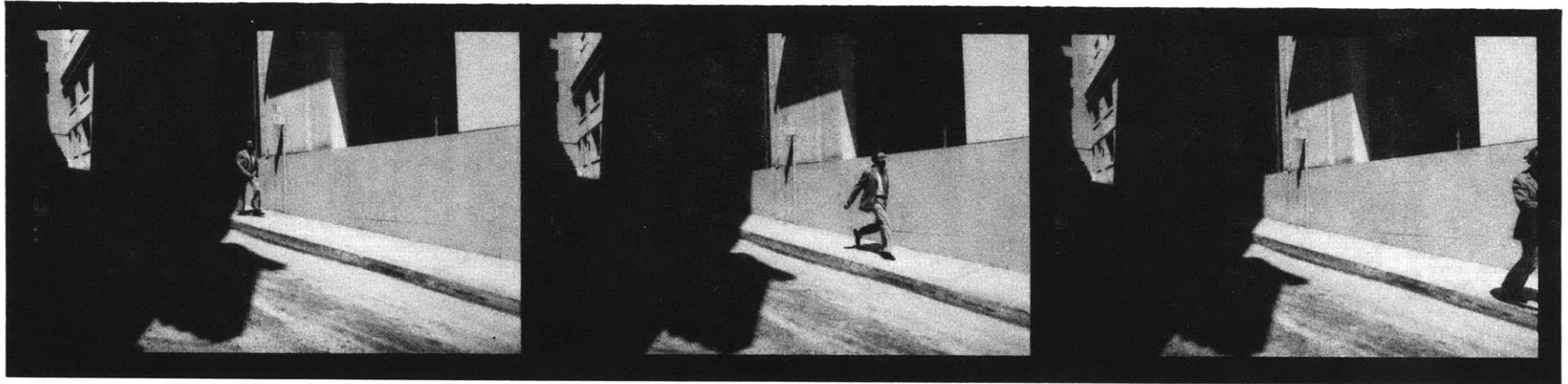

4.0 CONCLUSION

4.0

CONCLUSION

The design example presented above attempts to visualize very schematically and evaluate the density of one of the many possible designs regulated by a tissue model. The goal of this study, however, is not to present a design for a residential project on the block scale, but to introduce the urban tissue methodology of SAR 73, to use the method to analyze an existing urban fabric, and, by developing tissue rules which assimilate the specific characteristics of the urban environment, to apply the method.

SAR 73 was developed in the Netherlands, where nearly eighty per cent of all new housing construction is publically subsidized in one form or another and, therefore, subject to governmental regulation. Dimensions of the Dutch zoning distribution must relate to official standards, which regulate the sizes of rooms and dwellings, land coverage, and floor area ratio for subsidized housing projects.

The analysis of the Alamo Square region demonstrated the characteristics of built elements and the block fabric in contrast to the generic SAR 73 zoning and examined the morphological characteristics of this urban environment. It was shown that although the percentage of public housing projects is increasing, privately owned buildings and privately financed renewal projects dominate this area.

Because most new and restored buildings are privately owned and projects are developed on a relatively small scale, the individual can influence the built environment. Buildings on a small scale, owned, built and maintained by different individuals, can create more differentiation in form, functions, materials and designs than large homogeneous built structures. The SAR zoning system provides regulations for the tissue level and proposes rules for the adaptation of the single building to the existing morphology. It is not dependent on a specific construction method or building type and permits individual floor arrangements, as well as an opportunity for the owner to express himself to the public, by styling and decorating the outside of the building in his or her own way.

This study emphasizes the revitalization of the urban character of this district. Morphological regulations and the proposed zoning distributions are the results of a complex approach dealing with the living quality of the entire urban context. But, this study does not propose SAR 73 as the ultimate method to deal with revitalization problems in urban tissues. Supports, as a conceptual approach to the rehabilitation process of an urban fabric like that of Alamo Square, which are more responsive to individual and collective demands are offered as an additional tool in the renewal process. No method can guarantee a successful project. It is the residents who must save or create a healthy neighborhood, but a transparent planning process can help eliminate failures in the planning stage.

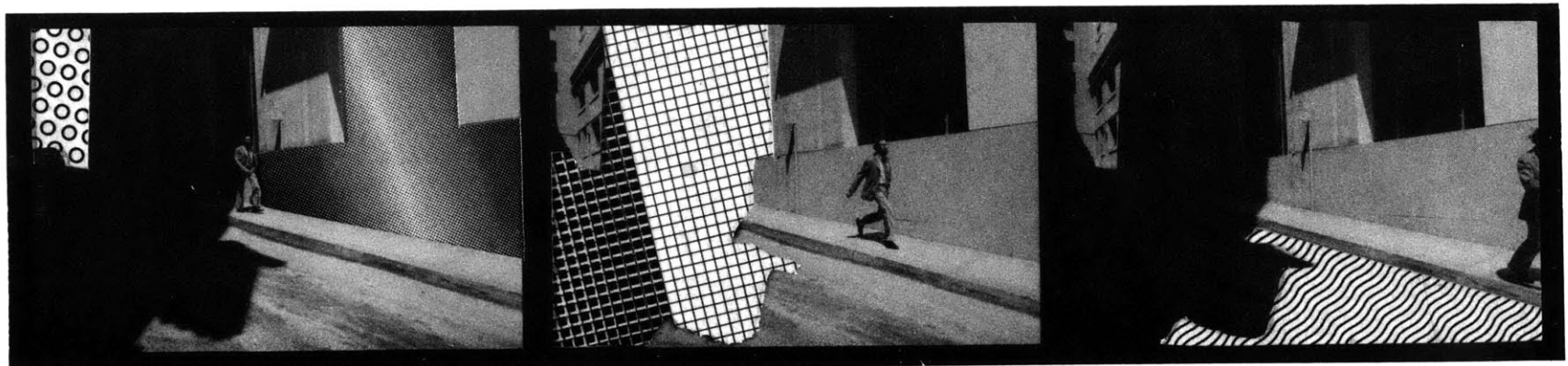

5.0 APPENDIX : A COMPUTER-AIDED GRAPHIC QUANTIFICATION TECHNIQUE FOR TISSUE MODELS

BLOCK 822 BUILT-OPEN SITUATION 1976

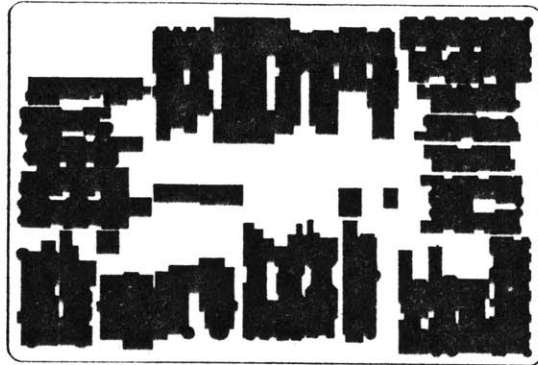

FIG. 146

BLOCK 822 ZONING

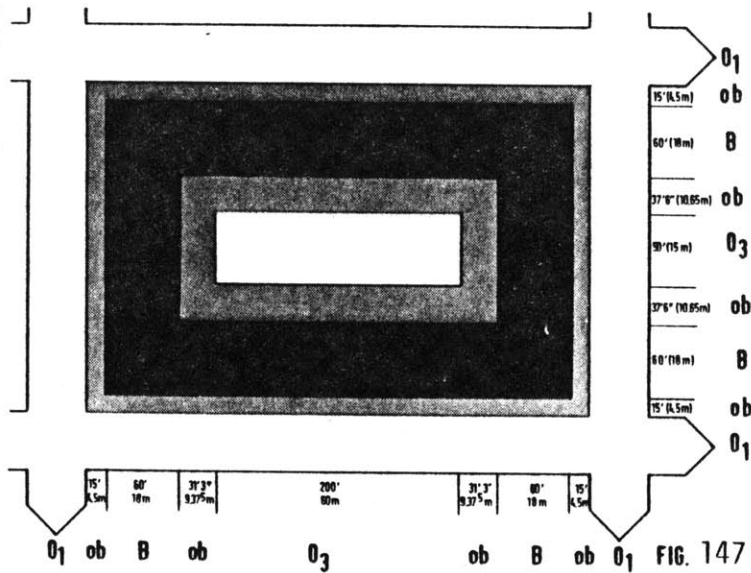

FIG. 147

BLOCK 822 SUB-ZONES AND SUB-MARGINS

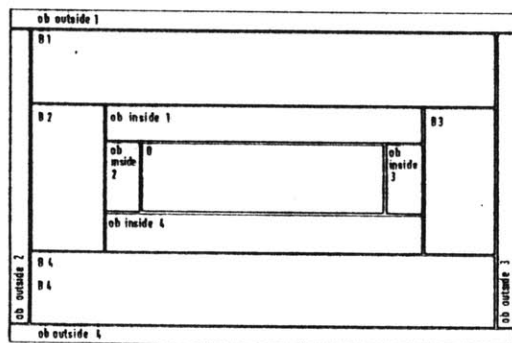

FIG. 148

5.0

APPENDIX: A COMPUTER-AIDED GRAPHIC QUANTIFICATION TECHNIQUE FOR TISSUE MODELS

For the density analysis of the existing block fabric a computation of the land coverage per block was needed. The differentiated shape of Victorian buildings, with add-ons, recesses and bays, impeded the process of measuring the land coverage of a single building (Fig. 146). Computation for an entire block was very time consuming; quantification of the fifty blocks which were surveyed became very difficult.

To accelerate this process, a computer-aided quantification technique was applied. Using the "Digital Transparency Technique,"¹ it was possible to produce a visual input of maps with a vidicon camera (Sierra Scientific Corporation's standard high resolution video CCTV camera). The vidicon camera was linked to the Architecture Machine Group's MAGIC System via an Interdata Model 7/32 k-byte mini-computer. To enable the use of varying colors and shapes, a Ramtek RM-9300 image-display system was integrated into this

¹Louis Weitzman, "Digital Transparency Applied to Interactive Mapping" (M.Arch.A.S. thesis, Massachusetts Institute of Technology, 1977).

set-up. This is a full-color raster scan display system, controlled by a microprocessor. With this system it was possible to digitize the zoning system of the existing block fabric (Fig. 147) and collage it with the digitized built/open map of the tissue. Using the Summagraphics Tablet, it was possible to select areas of B-zones and ob-margins which were displayed on the monitor.

It was necessary to subdivide margins and zones in sub-areas as indicated in Figure 148. The Ramtek device scanned these areas and differentiated between built and open areas. The display and print-out included the percentage of built elements per sub-area and the total built/open percentage for the entire block. The output of this technique is as exact as the visual quality of the mapping material.

It is, of course, too involved and therefore unnecessary to use this method for the analysis of a single building, but it can be an extremely useful tool in the quantification of existing built elements of a large number of blocks or for new developments such as tissue models.

In the future it will be possible, using the hardware of the Architecture Machine Group, to code different quantities of information of a map and to scan them separately. This will be very helpful in analyzing statistical maps and selecting and quantifying different information which is notated in one map.



6.0 BIBLIOGRAPHY

6.0

BIBLIOGRAPHY

Works about SAR:

Habraken, N.J. Supports: An Alternative to Mass Housing. New York: Praeger, 1972.

. Three R's for Housing. Amsterdam: Scheltema and Holkema, 1966.

. Variations: The Systematic Design of Supports. Cambridge, Mass.: Laboratory of Architecture and Planning, MIT, 1976.

Plan 3, March 1970. Eindhoven: Stichting Architecten Research.

Plan 12, December 1970. Eindhoven: Stichting Architecten Research.

Stichting Architecten Research. Deciding on Density: An investigation into high density allotment with a view to the Waldeck area, The Hague. Eindhoven, Holland: Stichting Architecten Research, 1977.

. SAR 73, The Methodical Formulation of Agreements Concerning the Direct Dwelling Environment. Eindhoven, Holland: Stichting Architecten Research, 1973.

Other Sources:

Alexander, Christopher. A Pattern Language. New York: Oxford University Press, 1975.

Bakema, J.B. Woning en Woonomgeving. Delft: Technische Hogeschool, 1977.

Banham, Reyner P. "A Home Is Not a House," Art in America. April 1965, pp. 20-79.

Becker, Heidede. Wahrnehmung in der Staedtischen Umwelt. Moeglicher Impuls fur Kollektives Handeln. Berlin, 1972.

Boudon, Philippe. Lived-in Architecture: Le Courbusier's Pessac Revisited. Translated by Gerald Onn. Cambridge: MIT Press, 1972.

Eisen, Theodore A. "The Consistency of San Francisco Architecture," The California Architect and Building News. Vol. 3, No. 4.

The Foundation for San Francisco's Architectural Heritage, Directory 77, Rehabilitation advice and useful sources for owners of vintage buildings. San Francisco: The Foundation for San Francisco's Architectural Heritage, 1977.

Jacobs, Jane. The Death and Life of Great American Cities. New York: Random House, 1961.

Jenks, Charles. Ad Hocism. New York: Doubleday, 1976.

Lynch, Kevin. What Time Is this Place? Cambridge: MIT Press, 1972.

Marc, Olivier. Psychology of the House. London: Thames and Hudson, 1977.

Mitscherlich, Alexander. Thesen zur Stadt der Zukunft. Frankfurt: Suhrkamp, 1977.

Pawley, Martin. Architecture Versus Housing. New York: Praeger, 1971.

_____. Private Future. London: Thames and Hudson, 1976.

San Francisco, Department of City Planning. The Comprehensive Plan, City and County of San Francisco. San Francisco: Department of City Planning, 1971.

Staedte-Bauliches Institute der Universitaet Stuttgart. Arbeitsbericht 25, Grundlagen des Stadtgestalterischen Entwerfens. Stuttgart: Staedte-Bauliches Institute der Universitaet Stuttgart, 1977.

Trieb, Michael. Stadtgestaltung Theorie und Praxis. Dusseldorf, Bertelsmann, 1974.

Ward, Colin. Vandalism. London: Architectural Press, 1976.