

FORM, FINANCE, AND USE OVER TIME

By:
Paul Lukez

Bachelor of Environmental Design
Miami University
Oxford, Ohio
1981

SUBMITTED TO THE DEPARTMENT OF ARCHITECTURE IN PARTIAL FULFILLMENT OF THE
REQUIREMENTS OF THE DEGREE MASTER OF ARCHITECTURE AT THE MASSACHUSETTS
INSTITUTE OF TECHNOLOGY

MAY, 1985

© PAUL LUKEZ 1985

The Author hereby grants to M.I.T. permission to reproduce and to distribute publicly copies of
this thesis document in whole or in part.

Signature of the
Author _____

Paul Lukez
Department of Architecture
May 17, 1985

Certified by _____

Ranko Bon
Assistant Professor of Economics in Architecture
Thesis Supervisor

Accepted by _____

~~Julie Messervy~~
Chairperson, Departmental Committee on Graduate Students

MASSACHUSETTS INSTITUTE
OF TECHNOLOGY

JUN 03 1985

Rotch

LIBRARIES

"If it is asserted that civilization is a real advance in the condition of man,--and I think that is is, though only the wise improve their advantages,---it must be shown that it has produced better dwellings without making them more costly; and the cost of a thing is the amount of what I will call life which is required to be exchanged for it, immediately or in the long run."

The Variorum Walden, by Henry David Thoreau.

FORM, FINANCE, AND USE OVER TIME

By
Paul Lukez

Submitted to the Department of Architecture on June 1985 in partial fulfillment of the requirements for the degree of Master of Architecture

ABSTRACT

This thesis is about making buildings affordable. It will explore thinking of buildings as being comprised of nearly decomposable systems of different lifespans. A nearly decomposable system is a system in which the links and relationships between the elements of it are stronger than its relationships to the elements of other systems. Nearly decomposable systems are subsystems of larger systems in which the interactions between subsystems are weak but not negligible.

The four nearly decomposable systems of a building to be considered in this thesis will include: the structure, the exterior envelope, the interior, and the furniture. Each system will be analyzed according to the input it requires and the output that it provides the other, both initially and over time.

Each decomposable building system can be associated with different users: tenants, owners, investors, or others, depending on what the building requires of the users and on the ability to meet those requirements. Each decomposable system can be financed by a different financier or with a different financial mechanism. Similarly the input and output of the financial system both initially and over time will be analyzed. My intent in doing so is to match the user with that building system which meets the user's needs while staying within the constraints of the financial system.

An analysis of the input and output of each system will be followed by a description of an economic model which was created with the intent of modeling the relationships between the three systems as they are played out in the average priced American house. Several strategies are superimposed on the model to demonstrate ways in which the affordability gap can be closed.

Thesis Supervisor: Ranko Bon
Title: Assistant Professor of Economics in Architecture

TABLE OF CONTENTS

Abstract	3
Acknowledgements	4
Table of Contents	5
Preface	9
-Process		
-Definition of Terms		
-Intent		
PART 1: The Problem and the Idea	13
-The Problem		
-The Idea		
-Why Use Nearly Decomposable Systems		
-A Definition of Affordability		
-Affordability Redefined		
-Decomposable Systems		
-Multiple Users		
-Multiple Financial Systems		
-Matching Input and Output		
-Time/Phased Structure		
-Behavior of Systems		
ANALYSIS OF EACH SYSTEM		
The Building System	23
-The Input Required		
-A.1 The Structure		
-A.2 The Building		
-A.3 The Interior		
-A.4 The Furniture		
-Building's Output		
-Deductions as Output		
-Interest on Debt		
-Depreciation		
-Equity		
-Value Appreciation		

The Use System	30
-Owner-Occupant Input/Output		
-Tenant-Owner Input/Output		
-Non-Occupants		
-Investor		
-Output Required		
-Socially/Politically Motivated Users		
Finance System	35
-Loan Mechanism		
-Loan Types		
-Fixed Rate Mortgage		
-Variable Rate		
-GPM		
-Shared Appreciation		
Charting the Input and Output of Each System	37
-Building - Use		
-Use - Finance		
-Building - Finance		
Synthesis	41
- The Principles		
- The Strategies		
PART 2: Description of the Model	45
-What the Model Does		
-The Technical Construct of the Model		
-Level One: General Data		
-Level Two: Life Cycle Generators		
-Level Three: The Synthesis		
Major Assumptions	50
Level One: Starting Points	51
-Description of each Spreadsheet		
-General DATA .!l		

-General DATA .2

Level Two: Lifetime Generators 54

-A.1.....A.4

-Financial Resources

Level Three: Synthesis 57

-The synthesizer

-IRR/NPV. analysis

Part 3: The Strategies

The Base Line Model 59

-The Purpose

-The Assumptions

-Results/Analysis

-Application

-Issues/Problem

Multiple Financing 69

-The Idea

-The Assumption

-The Result/Analysis

-Application

Multiple Ownership 77

-The Idea

-The Assumption

-The Result/Analysis

-Application

-Public Sector

-Private Sector

-Community Group

-Small Ad Hoc Developer

Phased Construction 89

-The Idea

- The Assumption
- The Result/Analysis
- Application

Supplimentary Income93

- The Idea
- The Assumption
- The Result/Analysis
- Application

Flexible Financing 99

- The Idea
- The Assumption
- The Result/Analysis
- Application

PART 4: Concluding Remarks 105

- Summary of the Results**
- Issues and Problems**
- Concluding remarks**

BIBLIOGRAPHY 115

APPENDIX 117

PREFACE

PROCESS

The aim of this thesis is to discuss the options available in thinking of buildings as comprising nearly decomposable systems of different lifespans, each of which can be owned, controlled, or used by different parties who in turn can finance each system separately.

- The first section will discuss the problem of affordability, and the interrelationships between the three different systems that are central in determining it: the building system, the financial system, and the user system.
- The second part of the thesis will describe the structure of the economic model which was constructed with the intent of replicating the behavior of the three systems.
- The third part of the thesis will examine the results of five different strategies that were superimposed upon the model to demonstrate viable means of overcoming the affordability gap.
- Finally, the potential of this method will be summarized and discussed.

DEFINITION OF TERMS

SYSTEM: an assemblage or combination of things or parts that form a complex or unitary whole. A system is present within an external environment. The internal environment, and its order and mechanisms, will allow it to be identifiable as a system in the environment.

A NEARLY DECOMPOSABLE SYSTEM: a subsystem of a larger system in which the interactions between it and other subsystem are weak but not negligible.

INPUT: the energy, information, material, elements, actors, etc. originating from the external world by necessity, choice or chance and act on a system or subsystem.

OUTPUT: the energy, information, material, elements, and actors that result from actions in the external world or the interaction of the elements within a system.

BEHAVIOR OF A SYSTEM: the way in which a system interacts with the environment, and the resulting input and output of that system.

INTENT

This thesis will attempt to develop an understanding of each of the three critical systems involved in making buildings, and specifically housing, affordable. It will attempt to understand how each system operates in isolation and in relationship to the other systems. The three systems are the building system, the financial system, and the user system. The building system will be defined as those physical elements and components which when integrated form a building. The financial system is that system in which financiers loan capital in return for profit and repayment. The user system comprises all parties that use a building, including non-occupants such as investors, developers, governments, or community groups.

Each system must work within the limits of its own internal order. A loan mechanism can not go outside the terms of the loan without endangering the solvency of the bank. Neither can the building's structure go outside the capacity and limits of the structural system without endangering the solidity of the building. Nor can the implicit or explicit social and legal agreements between the different users interacting in a building be broken without endangering the viability of continued use in a building.

The relationships and links between the building, financial and user systems are equally important in guaranteeing the capacity of all three to interact as one system. In order for a building to be a "living" system it must have more than just physical form enclosed in space. It must have the utility from which users benefit, and the users in turn must have resources available to meet the requirements of the building to sustain it so it can provide use. For a building to remain as a

living system this relationship must carry on through time, with the possibility of interchanging or replacing - in part or in whole - buildings, financing, or users.

Why Use Nearly Decomposable Systems?

If we accept the notion that the range of the affordable solutions will lie within the combinative possibilities between each of the elements of each of three systems, the range of possibilities is finite. This is part of the dilemma of today's affordability gap where one user cannot finance one building in its entirety. However if we think of buildings as comprising multiple component groups each of which requires different input and provides different output over time, and which in turn could match a variety of different user's needs, then the range of combinative possibilities would increase by a factor of the number of the decomposable groups.

What are the Nearly Decomposable Systems?

A nearly decomposable system is a system in which a relationship within the elements of one system is stronger than with elements of other systems. In a building, for example, the links, relationships and dependencies are stronger between the elements of a plumbing system than between the elements of the facade. Since these links between different systems and subsystems (i.e. plumbing and facade) are negligible, a change in one system will not necessarily destroy the integrity of the other system.

A building could be split up into four nearly decomposable systems. They are the structure, the exterior envelope, the interior and the furniture. The actual limits in demarcation of each system will vary with each building. In some cases what is structure may also be an interior wall. Or what is an exterior envelope may also be structure. The degree to which decomposable systems are intentionally designed as nearly decomposable, depends upon the nature of the materials used and method of the construction. There may also be a design intent which is to allow maximum freedom and detachability of each system. If the system of interior walls is

designed as a nearly decomposable system, the interior walls its configuration will be able to change with limited fear of actually altering or destroying the integrity of the other physical systems.

PART 1

THE PROBLEM

The search for affordable housing, which has long been a problem for low income earners, has encroached on the middle class. With the dramatic rise in real estate values in the 1970's and the rise in interest rate in the late 1970's and early 1980's, the cost of housing has skyrocketed. The average house today costs \$72,000. and the income required to qualify for a 30 year fixed rate loan at 13% for that amount is equal to \$34,000. Yet, today 's median income for a family of four in the Boston area is \$18,300. The American dream of homeownership is in danger of becoming a myth.

However, there are many individuals attempting different types of innovations and developments to close the affordability gap.

Building Systems: In the physical world of building, designers are trying to reduce initial costs by designing smaller and more efficient housing units. The design of clustered units and condominiums has also allowed the initial cost of housing to be further reduced by utilizing land more efficiently. Builders and manufacturers are incorporating manufactured components in a wider array of applications.

Financial Systems: In the financial markets deregulation has made available a whole set of new mortgage instruments and loan sources. Today consumers can choose to finance their homes with VRM, FLIP, GPM, SAM, etc., besides the old fixed rate mortgage. Today variable rate mortgages allow for reduced initial monthly payments, since the interest rate is linked to inflation and therefore the bank does not need protection against its fluctuations. Furthermore, new institutions are entering the financial market; quasi- governmental mortgage organizations like the Fannie Maes and Ginni Maes have allowed the secondary mortgage market to offer competitive loans. Developers, builders, manufacturers, insurance companies, syndicates, brokerage houses, and even large department stores are only a few of the examples of some of the new

parties involved. The "financial supermarket," where one can get a loan, buy and sell stock, buy insurance, as well as arrange a retirement plan is already taking the hold in retail establishments.

User Systems:The occupants themselves ultimately bear the responsibility of finding ways to reduce the cost of housing. Some users have accomplished this by accepting a redefinition of the American dream, by reducing the size or character of the dream. Condominiums are becoming an increasingly acceptable option, while the sizes of the units themselves have decreased. Sweat equity has proven to be another viable option for those individuals who make up in energy and desire for what they lack in equity. Some users who cannot own a dream will share it. Mingles, that is mixed singles living in shared living groups is another example of users attempts to reduce the cost of housing.

Each of the professional groups, institutions, and individuals mentioned above typically work within the limits of their respective professions. It is a difficult task for these actors to step outside of the limits of the their particular systems and integrate the benefits available to each system with the others.

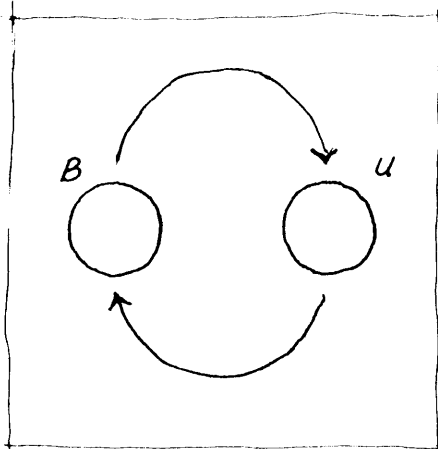

Fig. 1.1
The Building and the User

The Building's Output = Dwelling
 The Building's Input = \$
 User Output = \$
 User Input = Dwelling

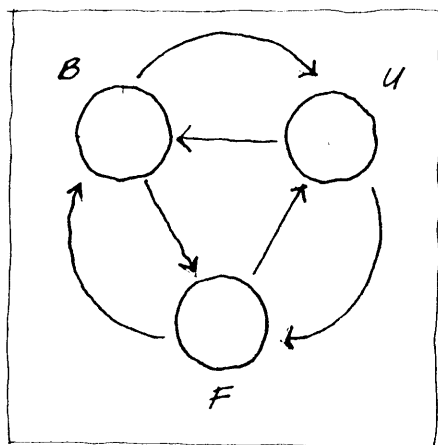

Fig. 1.2
The Building, User and Bank

A Definition of Affordability

Simply stated, affordability is a measure of a user's or a group of users' ability to meet the financial demands made on them by the purchase and maintenance of a building, with the resources available to them initially and over time.

Let us consider the simplest case when a user is in need of dwelling. A building can be purchased or self-built to meet the user's needs. The user's need is the provision dwelling; dwelling is an output provided by the building or an input to the user. If the user has enough capital to meet in turn the input required by the building, initially and over time, then there is no need for a financial intermediary. (Fig. 1.1)

Other output provided by the user can be utilized in place of capital. This includes: labor and materials, although the purchase of materials will most likely require an expenditure of capital by the user. Most users do not have sufficient capital to pay for a building directly. Therefore a second party must assist, a party capable of meeting the initial capital requirements. This has traditionally been the role of the bank.

The bank pays for the building in its entirety. In return for its initial output of capital, the bank receives input from the user equal to the loan amount, plus interest on debt. To come full circle, the user in turn receives as an input from the building a dwelling place, but must put out to the bank payments and interest. (Fig. 1.2) The user however also has to provide smaller kinds of output to the building which the bank will not fund. These include maintenance, and repair, which can require capital, labor and material.

If we dissect each of the building, finance and user systems, we can diagram the input and the output of each as follows.

The Building System:

Primary Elements: structure, exterior envelope, interior, and furniture.

Input : material, labor, maintenance, replacement

Output are: dwelling, deduction, rent, value, equity, beauty

(Fig. 1.3)

The Financial System:

Primary Elements: banks, financial intermediaries, insurance companies etc.

Input: repayment, interest, profit

Output: initial payment

(Fig. 1.4)

The User System:

Primary Elements: individuals, inhabitants, investors, governments

Input: dwelling, value, equity, beauty

Output: income, labor, material, value

(Fig. 1.5)

It is clear that in order for a building to be affordable to the user, the input required of each system, (Building-Finance and Use) must be met within the respective tolerance levels of each system. Otherwise one of the input/output links between each system could break and endanger the entire building, finance, and use system.

Today the average american house costs \$72,000 while the median income in Boston for the median family of four is \$18,300. The income and resources available to these users cannot meet the initial input required by a building. This is an affordability gap in its initial state (Fig. 1.6). Thus, even though the use required by the average family (dwelling) remains constant, the problem is largely a discrepancy between the size of the investment required to secure a suitable dwelling and the income available.

Affordability Redefined:

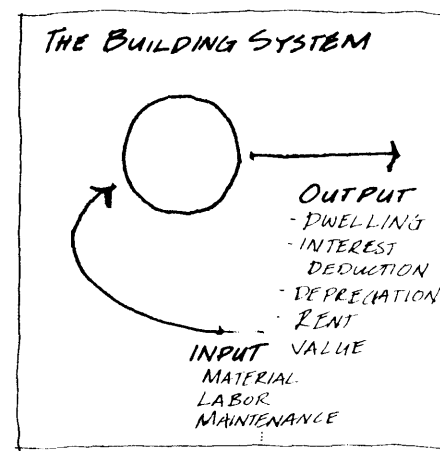

Fig. 1.3
The Building System

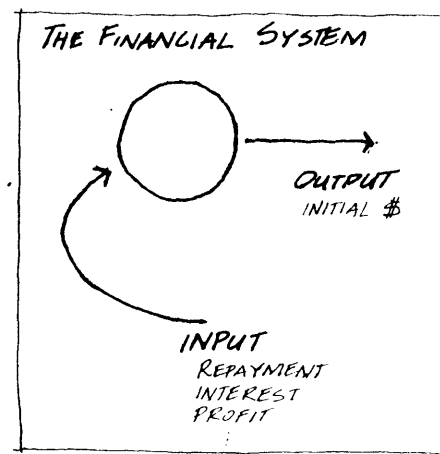

Fig. 1.4
The Finance System

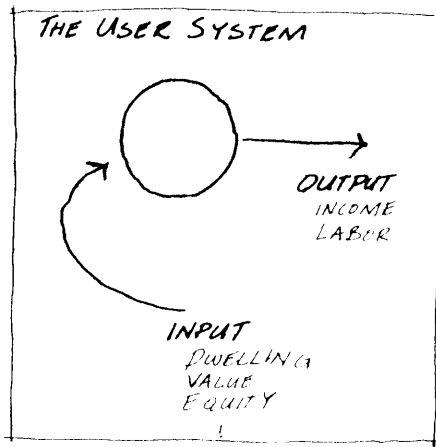

Fig. 1.5
User System

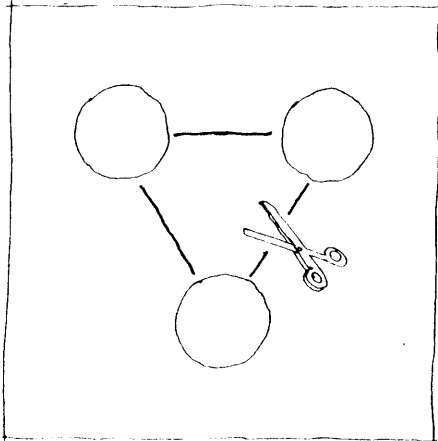

Fig.1.6
Breaking a Link

Thus it appears we can define affordability as a balance between all of the required and potentially required input and output of each system. If any of the input or output is strained beyond its tolerance levels then that input/output link will break. This in turn could endanger the viability and survival of the entire building, finance, and use system. The broken link could be replaced by entering another element such as a user, bank, or building which could be matched by the input/output requirements of the other two remaining systems. Otherwise, the life of the total system, -building, use, finance,- is terminated. There are two ways this could be represented diagrammatically, either as a triangle or a matrix. (Fig 1.8 & 1.9).

The triangle is a simplification of the triangle already used in previous examples. The affordability problem states that 1) a portion of the population does not have access to adequate building-finance-use systems in their initial configuration, and 2) if they do, certain tolerance levels of the input/output links are being unduly strained, in such a way that the user must either sacrifice input received from a building (minimized space and amenities) or overextend their output capacity (financial resources). (Fig. 1.10 & 1.11)

One would hope there might be a way in which 1) the building could be more accessible financially to a greater number of people, 2) the tolerance levels of the input/output links that bind building, finance, user systems could be sustained over the life of the building and the life of the users.

The ability of the building, finance and user systems to meet changing conditions depends upon the strength of the links binding them, which in turn depends on the input and output requirements of each of those systems and their subsystems. Therefore it would be possible to begin defining matrices that represent the input and output of each of the systems and the relationships between their subsystems. (Fig. 1.12 - 1.14)

Decomposable Systems

The question of affordability can be restructured into a new paradigm which can be useful in viewing the affordability problem in a new light. One such restructuring of the building is

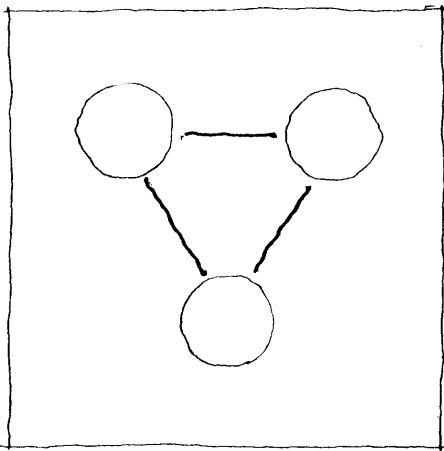

Fig. 1.8
The B-F-U Triad

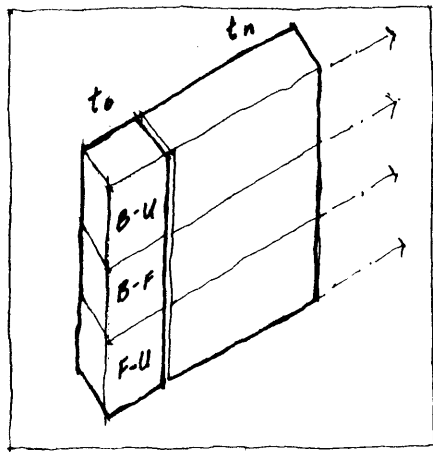

Fig. 1.10
The B-F-U Matrix over Time

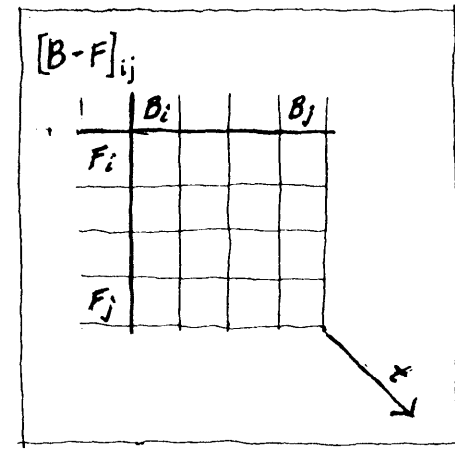

Fig. 1.12
The Building-Finance Matrix

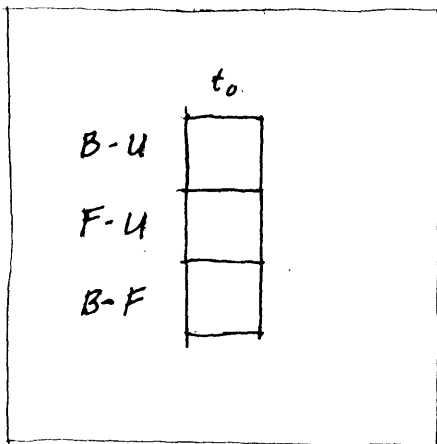

Fig. 1.9
The B-F-U Matrix

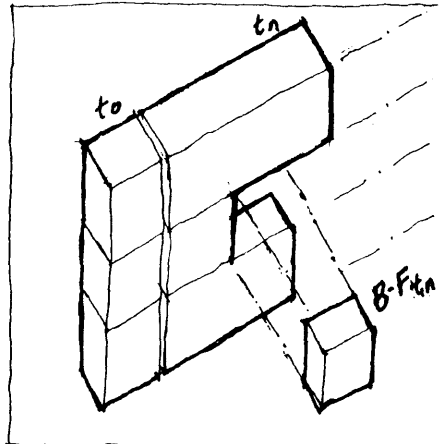

Fig. 1.11
Missing a Link at B-F t_n

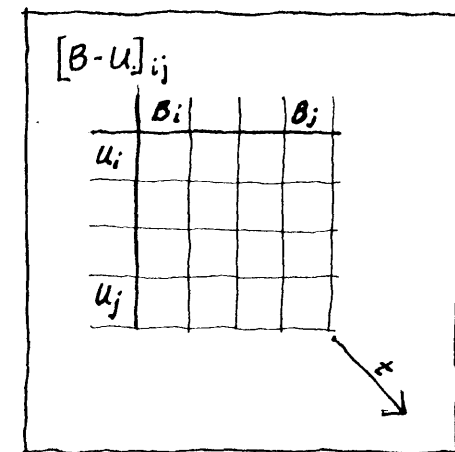

Fig. 1.13
The Building-Use Matrix

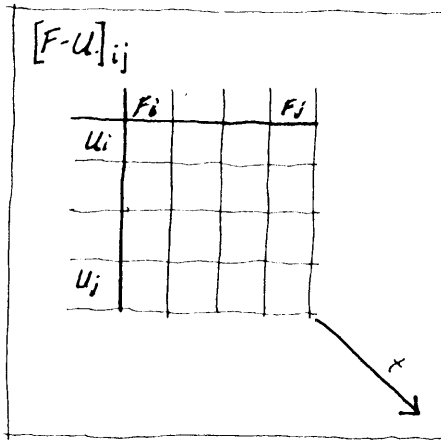

Fig.1.14
The Finance-Use Matrix

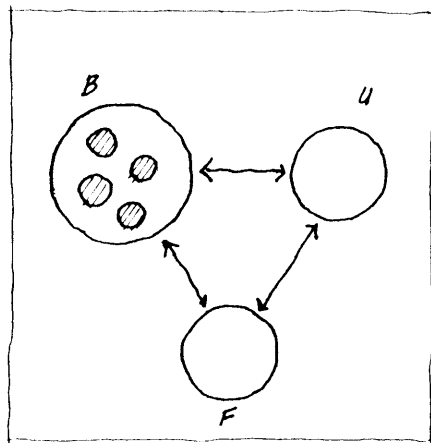

Fig. 1.15
Building As An Assemblage of Nearly Decomposable Systems

to assume that a building is a composite of more or less nearly decomposable building systems. A nearly decomposable system is where the links between the elements of one system are considerably stronger than the links with elements of other systems and can therefore be decompose without necessarily damaging the integrity of any one system. The nearly decomposable building systems can be categorized as follows: structure, exterior envelope, interior walls, and furniture. Each nearly decomposable building system requires input and provides output. If we think of buildings as compositely structured, the question of whether one user could afford one building would be restated. The question becomes instead which nearly decomposable systems can be both used and affordable by which users? (Fig. 1.15)

Since buildings give out a variety of output, besides use, such as equity, interest and depreciation deductions, rent, and appreciation, it is possible for non-occupants to find benefit in this building. Therefore, besides thinking of buildings as systems of multiple decomposable building components, we can introduce multiple users (Fig.1.16) The problem then becomes, how does one begin to match the input and output of each decomposable building system so that the users will benefit from the output of that building while simultaneously providing the required input of the building component?

One needs to consider that each building component produces different input and output when acted upon by different users. An example of how building component will react differently when acted upon by different users is the fact that a homeowner can only deduct interest on the mortgage debt, while a developer can deduct depreciation and interest on debts. All of the deductions, in turn, are dependent upon the income bracket of the respective users.

Multiple Financial Actors.

Besides having a building composed of multiple nearly decomposable building components and multiple users, there exists the opportunity to have multiple financial mechanisms within one building. Each user can be matched with a separate decomposable

building system, which in turn could be matched with a separate financial mechanism. (Fig. 1.17)
 This point will be discussed in greater detail in the section which analyzes each system.

Matching Input

The diagram of our matrix has altered from its original state with the inclusion decomposable building systems and multiple financiers, and users. If we accept our original assumption that the life of a building will be assured so long as each system (building, finance and use) is present, and that the input/output links between them are adequate, we can see now by our multilayered building, finance, and use diagrams and matrices that the potential for those objectives to be met has increased. The matrix diagram of this relationship over time is demonstrated in. As long as one of the elements in each of the categories is present, and the possibility exists that if one of the subsystems fail, the remaining subsystems within each system will have the capacity to withstand that loss, this matrix will have a higher probability of remaining a viable system. (fig. 1.19) If one of the elements is absent, it can be replaced by another element which has the capacity to survive on input lost and output required by that system.

The question arises as to what will cause the system and their bonds to break away, and once they do, how does one match the broken links to the other elements, or sources of input and output?

The concept of "valence" used in chemistry could prove useful. Each element and actor in each one of the BFU systems, (whether it would be a building component, user, or financial intermediary,) would have a valence, and a valence of each of these components would determine their likelihood of adhering to other BFU systems at critical intervals. Our goal should be to speculate on developing BFU systems which have a higher probability for allowing elements to adhere at critical times, thus increasing the longevity of the entire system.

Timed/Phased Structures

Besides matching other users financial mechanisms and users, there is another strategy to creating building-financial-user systems which are affordable and stable. This strategy reduces

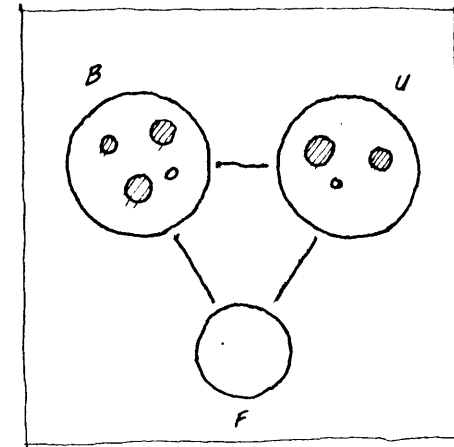

Fig.1.16
 Multiple Users

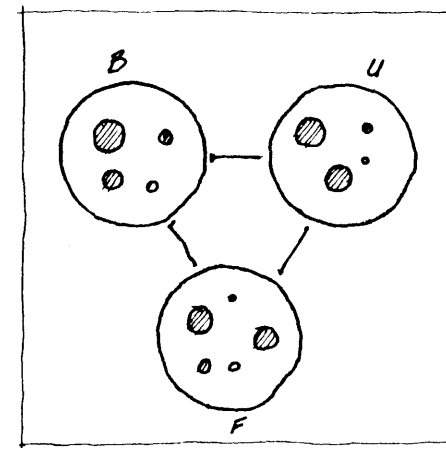

Fig. 1.17
 Multiple Financiers and Financial Instruments

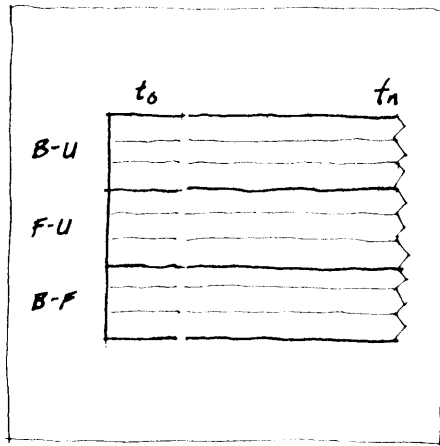

Fig.1.18
B-F-U Matrix with Multiple Subsystems

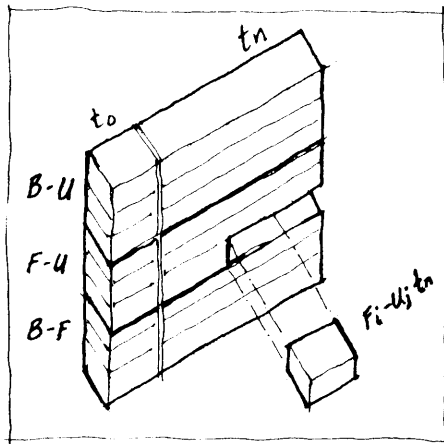

Fig. 1.19
B-F-U Matrix With Failed Link at
 $F_i-U_j t_n$

The B-F-U Matrix Still Survives

the input and output of each system down to the minimum levels required just to sustain the system and then over time to build in the capacity for meeting the original input and output as the resources become available. (Fig. 1.20) Therefore, the input and output of each system - buildings, finance, and use - can be altered and adjusted to meet the preferred conditions of each of the other systems, as long as there is a minimum of structure to bind and support the entire system. See strategy Phased Construction.

Behavior of Systems

In order to understand the behavior of BFU system to meet user needs initially and over time, it would be helpful to understand the behavior of each of the , and the building , financial , and user systems in isolation. By behavior, I mean what the input and output of each of the systems and their subsystems are and could be over time, and their ability to be matched with other sources of input.

Studying the input and output of the physical system is easier than making speculations of less determinable systems, such as use systems, which have the human element as a dominant determinant. I do not wish to presume that we could begin to precisely determine what the behavior of use systems would be over time, nevertheless, we can speak of the behavior of buildings quite definitively by studying the lifecycle costs of buildings and their subsystems.

By using lifecycle costs we can begin to understand the total cost incurred over the lifetime of each building component. The Lifecycle Cost Data Book by Dell' Isola and Kirk classifies each building component and its expected lifetime costs. The following section will analysis each system's behavior in greater detail, specifically analyzing what the input and output will be over the building components lifespan. Besides understanding the input and output of the building, designers can tell us about the use behavior of buildings, that is their ability to meet desired use requirements over time. Likewise, tax lawyers , accountants, and public policy makers can speculate on the potential behavior of the tax output of a building.

The next section will describe the relationships of the behavior of each of the three systems over their lifetime. It will analyze: 1.) the components/elements/actors of each system. 2.) the input and output required of each system. 3.) the tolerance levels that each system has to input/output fluctuations. Note that all of these will be studied over the lifetimes of these systems.

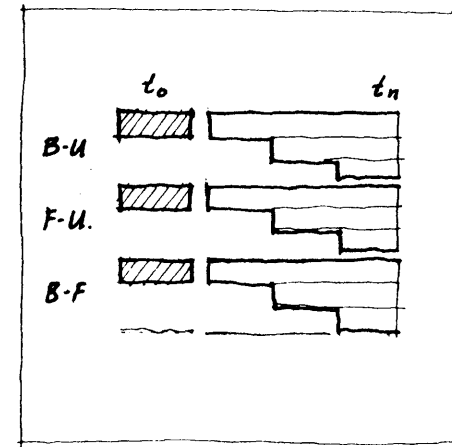

Fig. 1.20
Time-Phased B-F-U Matrix

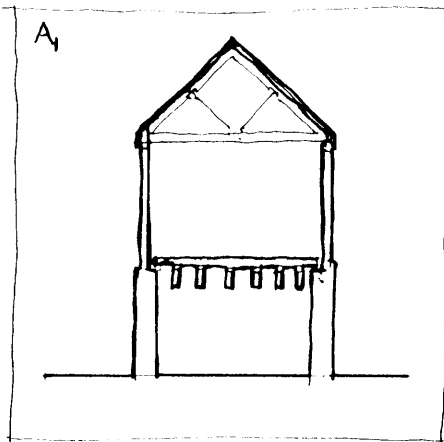

Fig. 1.21
The Structure
-Foundation
-Primary Structure
-Primary Roof Structure
-Utility Access -Primary Stairs

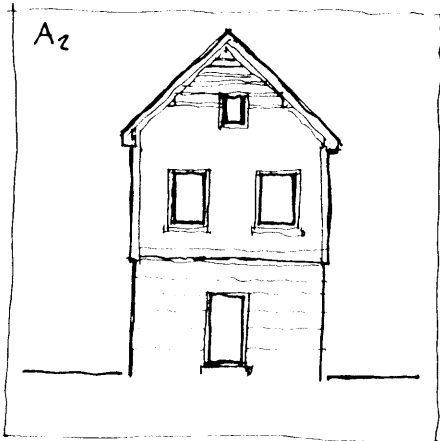

Fig. 1.22
Exterior Enevelope
-Wall Material/Covering
-Insulation
-Roof Membrane
-Doors
-Windows -Decks etc.

ANALYSIS

The following section will be looking at each system and its behavior over time. Each system, its actual and potential actors, will be analyzed according to the level of input and output of each of these elements and their tolerance to change. I will also be looking at the major determinants of those tolerance levels.

In the second part of this analysis, I will also be examining the relationships of some of the critical links between building,, finance, and use. For instance, the relationship of space needed by a user vs. the ability of the user to pay for that space will be examined, as well as the input and output required by a building and the ability of the user to pay for that input and output.

THE BUILDING SYSTEM

One of the major assumptions of this thesis is that buildings can be thought of as a system of nearly decomposable systems. One could decompose a building in many ways, but the way that I have chosen to do so is by grouping them by their lifetimes. This is because , as I hope will become clear in later sections, there is a direct correlation between the useable lifetime of a component, its design, its method of financing and depreciation and the use it can provide.

The lifetimes of the building components can be categorized into the following categories:

A.1	Structure	60 years
A.2	Exterior envelope	30 years
A.3	Interiors	15 years
A.4	Nonfixed interior elements	10 years

Each one of the above categories in turn can be split up into other subsystems which all have their own input and output. This section will attempt to list these subsystems and describe their input and output (Fig. 1.21 - 1.24)

The major input required of a building component is:

1. Initial Costs
2. Financing Costs
3. Maintenance and operation costs
4. Energy Costs
5. Replacement costs

Each one of the above can be split up into other categories such as labor, material, and overhead and profit. Together, each one of the input can be charted over the useful lifetime of the component.

1. Initial costs include :

- labor
- material
- overhead
- administration
- profit

If we chart these costs over the lifetime, they will obviously occur in the first years. (Fig.

1.25)

2. Financing Costs

Most people cannot afford total initial costs and must therefore seek outside financing. Outside financing requires the following payments:

- down payment
- interest
- amortization

Different types of mortgages are available to meet the needs of different users., but their payment schedules tend to be relatively stable over the lifetime of loan. (Fig.1.26)

3. Maintenance and Operation Costs

Maintenance and operation costs assure longevity of a product's useful life. They include such costs as:

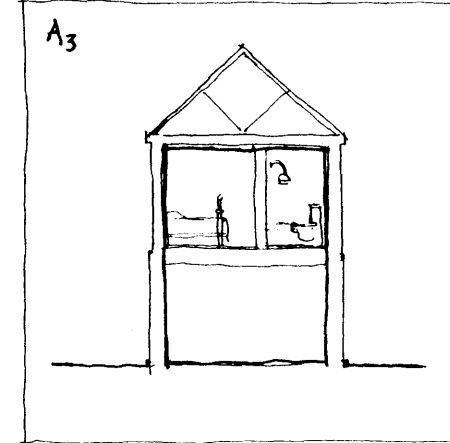

Fig. 1.23
The Interior
-Interior Walls
-Kitchen
-Bathroom
-Mechanical System
-Interior Doors/Windows

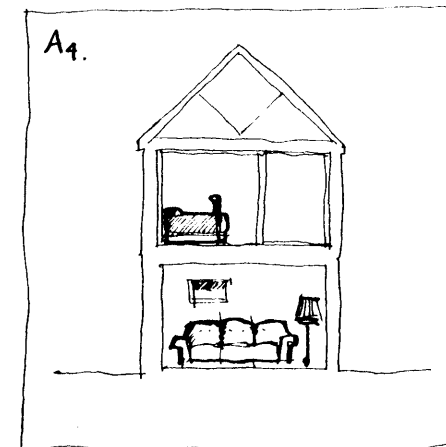

Fig. 1.24
Furniture
-Furniture
-Appliances
-Temporary Structures

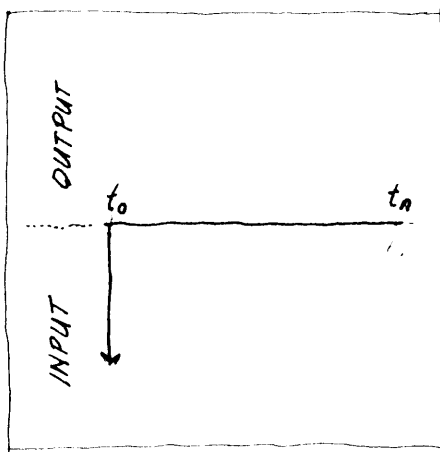

Fig. 1.25
Initial Input Required by Building

Initial costs = (labor) + (material) +
(overhead) + (Profit)

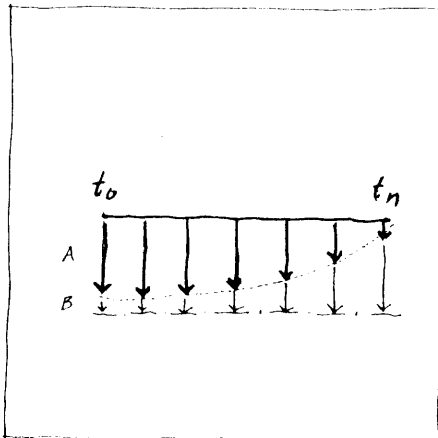

Fig. 1.26
Financing

Financing = Interest & Amortization
A=Interest
B=Amortization

- regular maintenance costs
- custodial care
- regular minor repair

Typically, replacement costs under five thousand dollars per year, or items having a lifetime of less than five years, are included in this category. The costs of maintaining and operating building components can be derived from or found in lifecycle data books. (Fig.1.27)

4. Replacement Costs

Replacement costs are those costs which occur when a component requires replacement in part or full. The cost of replacing a component is equal to the cost of replacement in the year of replacement minus the salvage value of the replaced component. (Fig.1.28)

5. Energy Costs

Energy costs can be included in operation costs and are defined as those costs required to operate machines, operations, and maintenance equipment. These costs depend on the price of energy and the type of energy system used. (Fig. 1.29)

Why have these lifetimes and categories been chosen?

The lifetime categories are a result of looking at a building and thinking of which parts of a building were nearly decomposable and could be designed as such.

The links between the elements of a structure, namely the foundation, the structure, the roof trusses etc. are stronger to each other than their links to other systems such as windows. In each building, the limits of a decomposable system can be different.

But one could make the claim that the correlation between a building's physical decomposability and a building's decomposition by their economic lifetimes is similar and useful. Therefore, I have chosen to cluster the decomposable systems around four average lifetime groups. This is not to say that every item in each lifetime group will be in need of replacement at

precise increments of time. Instead it is simple intended to act as a useful guide in clustering component groups in more or less similar physical and economic groupings.

A Building's Output

Each component of a building has a number of different output. They include:

1. Use
 - people
 - machines
 - symbols etc.
2. Tax Deductions
 - Interest deduction
 - Depreciation Deduction
 - Other Deductions
3. Equity
4. Value

1. Use

Use is difficult to measure because of its non quantifiable aspects. When a use is met or not met is a fuzzy question. It is not like calculating what a building will cost. Never the less it is one of the critically important ingredients in maintaining the balance in the building-finance-use system, that is the balance between the input and output of each of the three systems, must be within the tolerance levels acceptable to the survival of each. (Fig. 1.29)

Utility and use in buildings can be described as their ability to meet the desired physical, social, and economic needs of users. What standards are used to decide if a building meets the physical and spatial use objectives? In the case of a bedroom, for example we know that a user needs a bed, and that the bed has a minimal dimension which in turn requires a means of access of some dimension. And yet, determining the dimension of the rest of the bedroom is less quantifiable and subject to a variety of other factors. The norms which determine what a suitable

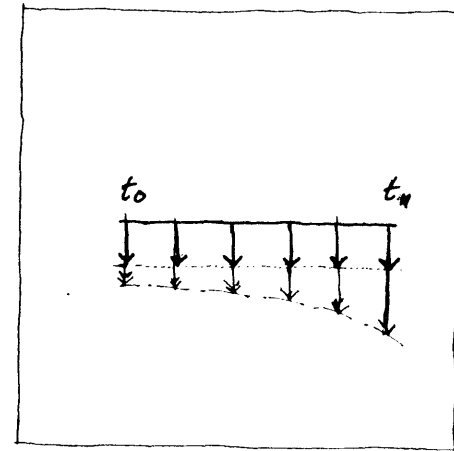

Fig. 1.27
Maintenance/Operation

$$\text{Maintenance} = (\text{maintenance}) + (\text{materials}) + (\text{wages})$$

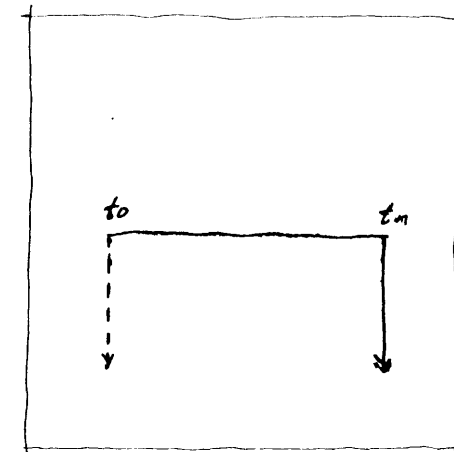

Fig. 1.28
Replacement

$$\text{Replacement} = (\text{Initial Cost}) * (\text{Future Value}) - (\text{Salvage Value at } t_n)$$

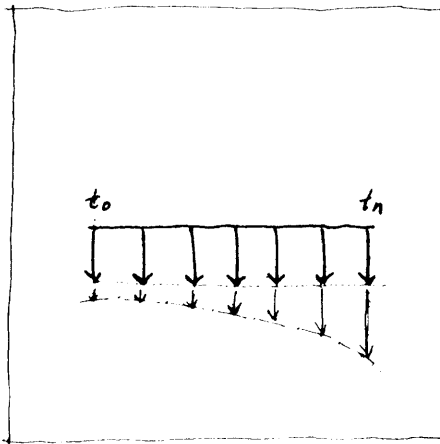

Fig. 1.29
Energy

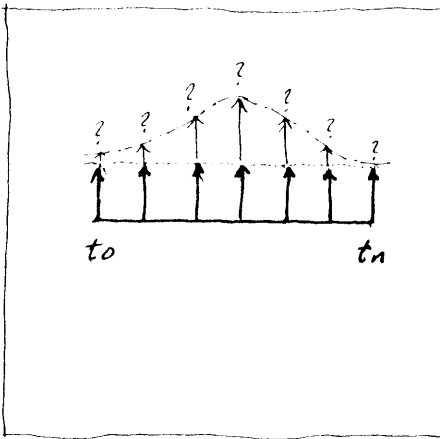

Fig. 1.30
One Building's Non-Quantifiable Output
is Use

size bedroom are and should be depends on the societal norms and the norms of the individual user. The norms determine the tolerance levels of each user.

A.1 The Structure.

The structure provides the output of support to a majority of the remaining elements of the building. The design of a structural system can either limit or allow for a greater variety of uses carried by one building. For example in a structural system which consisting of solid load bearing walls in a square configuration, where the initial size of the rooms and the size of the structural system are identical, it would be impossible to ever have in the future rooms that were several times larger or smaller without breaking out of the limiting structural system. If, however, the structure is designed to both provide enough shelter and allow for changes in the types of rooms, the building system as a whole will have a higher likelihood of providing a wider range of use output and therefore a greater chance of surviving as a system.

A.2 The Building Envelope.

By definition, the envelope is what protects the user-occupants as well as the building itself from the elements of weather. It is unlikely that the user will find suitable dwelling in the structure itself, i.e. without the envelope. However, it is likely the user may find the beginnings of minimal definitions of dwelling in the structure and the envelope.

Thus the primary output of the building envelope is the protection from the elements for both the rest of the building as well as its occupants. Other output of the exterior envelope includes the demarcation of public and private zones.

A.3 The Interior Definition

The output of this group is the definition of smaller spaces and rooms which provide different levels of privacy. This is the family of components which through the manipulation of its elements can be finetuned to meet specific user-occupants' dwelling needs.

A.4 Furniture.

This component group provides the use output which provides the final form of inhabitation.

Deduction as Output

Tax deductions in the U.S., as they relate to buildings, come primarily in two forms: deductions on interest paid on debt, and deductions equal to the depreciable life of a building per year. The owner-occupant can only deduct the interest paid on debt, while the investor can deduct both interest paid on debt and the allowable yearly depreciation.

Deduction on Interest on Debt:

If a user owns a house, and the house is financed with a mortgage requiring a payment of six hundred dollars a month, the portion of that payment that goes to interest will be proportionally higher than the amount that goes to amortization in the initial years. Assume that in year "x" of this mortgage, the interest on debt is equal to \$500, while \$100 goes to amortization. If the user is in the 25% tax bracket, the value of the tax deduction will be 25% of \$500 or \$125. Therefore the real payment for housing is not \$600, but \$475, including interest deduction. As the income level rises, so does the proportionate tax deduction, as well as the government's subsidy rate. (Fig. 1.31)

Depreciation

A depreciation deduction is allowed by the IRS. It is intended to let investors deduct from their profit maintenance, repair, and replacement costs incurred in the operation of a building. It is also meant to encourage investment in buildings by offering faster depreciation terms than the real lifetimes of buildings would require. The depreciation deduction allows one to depreciate the usable lifetime of a building in yearly increments. That is, an entire project's value when built or bought (minus the land value) can be depreciated at a straight line or accelerated rate. The lifetime of that depreciation cycle is anywhere from 15 to 30 years and does not necessarily a direct correlation to the actual lifetime of the building, since considerations of tax incentives often motivate policy decisions on lifetimes. In recent years, the depreciation rate has been eighteen years. This means that an investor can deduct one eighteenth of the value of a property for eighteen years when using a straight line depreciation. On a \$180,000 investment,

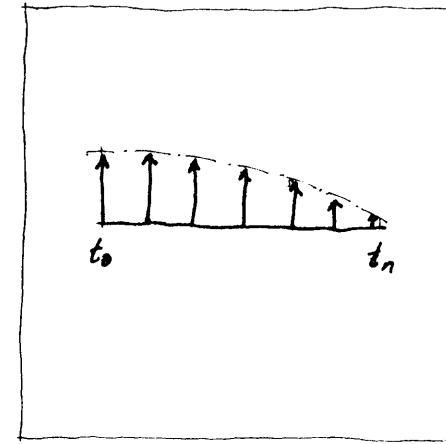

Fig. 1.31
Deduction on Interest on Debt

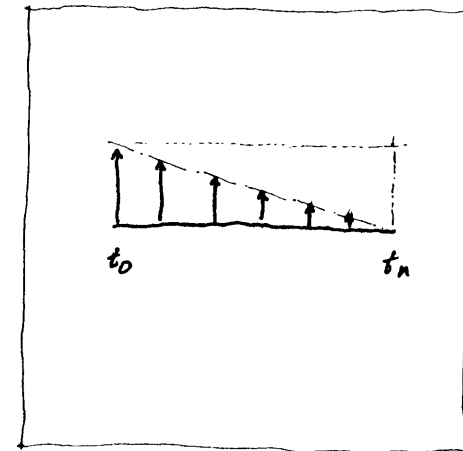

Fig. 1.32
Deduction on Depreciation (straight Line)

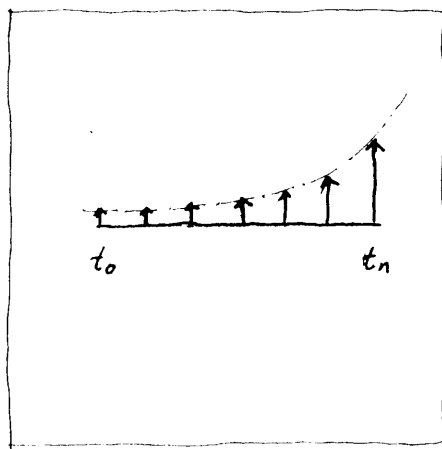

Fig. 1.33
Amortization/Equity

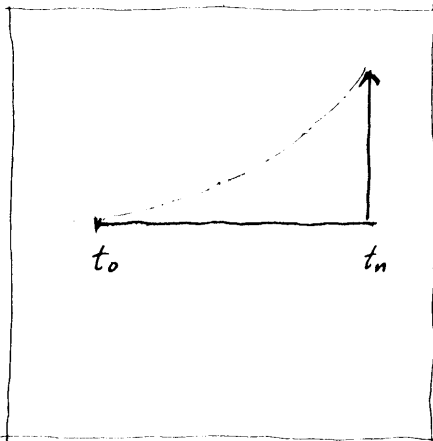

Fig. 1.34
Appreciated Value

that would mean that \$10,000 can be deducted per year. To an investor in the 50% tax bracket, this would have a cash value of \$5,000. (Fig. 1.32)

One can also use accelerated depreciation where the remaining portion of a building's usable lifetime can be multiplied by an accelerated factor in each successive year. The allowable accelerated factor is 150%; in the previous example, the first year depreciation would be increased to 150% of \$10,000 or \$15,000. This would have a value of \$7,500 in the first year.

Other potential output could include historic credits, special depreciation on machinery, etc. Most typically, however, entire buildings are depreciated as one unit. Buildings can be depreciated in their entirety minus the land value (typically 15% of total value), while sometimes investors find it useful to use shorter term depreciations of mechanical items in order to recoup their value at a faster rate.

Equity

Equity is being built up throughout the lifetime of ownership through the repayment of a loan. Typically, the initial downpayment and the amortized portion of a loan are those portions which contribute to equity. Another source of equity is appreciation, which can only be realized upon sale. (Fig. 1.33)

Value Appreciation

Even though a building is a depreciable item it manages to generate value. The value however, does not originate so much from the building itself, or the remaining depreciable life of the building, but from the value it has added to the land by its presence and use. Thus the car in the garage does not appreciate in value even though like the garage it is a depreciable good. Since the garage is a fixed object it is associated with the land and can therefore benefit from value it adds to the land and its appreciation over time. (Fig. 1.34)

Therefore, one of the major assumptions in using nearly decomposable building systems is that they should be associated with the land and therefore can retain value that it adds to it by its presence. Unless the decomposable system itself is intended to be disassembled from the

building and moved during its lifetime, as in the case of furniture (but not in the case of kitchens), each decomposable system retains the value which is proportionate to the overall cost of that decomposable unit at the time of sale. Therefore, each building component has the potential to provide output over the lifetime of the building in the form of appreciation no matter what its depreciable lifetime.

THE USE SYSTEM

How does one begin to categorize and chart the input required of a user? First one must distinguish the types of users. I will assume that there are two main categories of users: occupants, and non-occupants.

OCCUPANTS

- Owner-occupants
- Tenant-occupants
- Squatters
- visitors
- General public

NON-OCCUPANTS

- Investors
- Syndicators
- Developers
- Banks
- Governments

The first category of users' primary input required of a building would be dwelling. In the case of the owner-occupant, the user might also seek a return on investment, equity, etc. The occupant's ability to provide output would depend on the user's financial resources, which in the case of the squater would be nil.

Each user occupant will have different use needs during different parts of their own lifetimes. The user space requirement will depend upon the size of the user group, the nature of

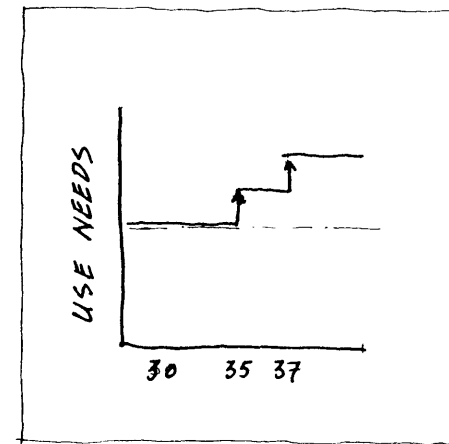

Fig. 1.35
Use Needs

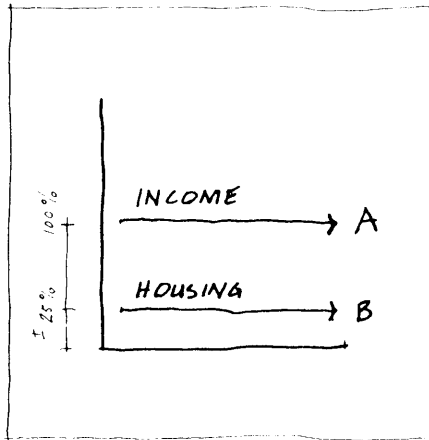

Fig. 1.36
Income Available For Housing
A= Total Income
B= Income Available For Housing
= 25% (+/-) "X" % of A

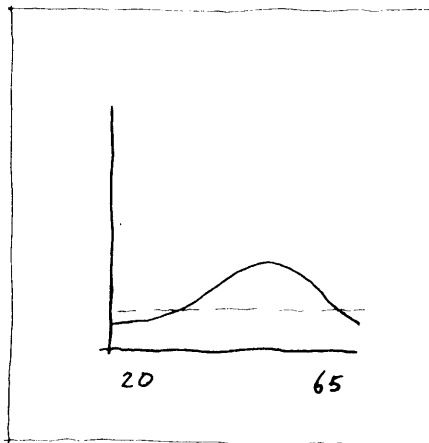

Fig. 1.37
User's Earnings over a Lifetime

their activities, and their available resources. Consider the case of a couple over a forty year lifespan. Assume that they get married when they are both thirty-years old, and have two children when they are 35 and 37 years of age. Assume that these children will live with them for twenty years and then leave. Their space needs, barring all other constraints, would take on the appearance of the graph below. (fig. 1.35)

Of course, there are many other determinants which could untidy this diagram. But what is important to note is that if there is a jump in the space needs, the building has to accommodate that need for the users. Otherwise, the users will either have to move or sacrifice their need. Thus if the discontinuity in the lifecycle pattern of a family is beyond the building's ability to adapt, another form of accommodation must take place.

A user's required output will depend on the financial resources available to that user. These include:

- income
- wealth
- labor

If we assume that a family earns \$18,000 per year, over a lifetime, (assuming that there is no inflation), then that family can by standard bank mortgage applications can only afford to spend 28% of their income on housing. The diagram (Fig. 1.36) shows what the affordability gap would be in the case of constant available income and but changing needs.

However, most people have different income levels over their lifetime, with many discontinuous patterns over their lifetime. It is safe to assume that in typical family lifecycle patterns, income levels are lower initially and reach a peak somewhere in the latter half of the users lifecycle, returning to a lower level during retirement. (Fig. 1.37)

When we overlay the user's required input (dwelling) and the available output (resources), against each other, we discover that when there is a discontinuity in use needs, there may not be a simultaneous and compensating change in income. If the use curve rises without a simultaneous adjustment in income, and the rise and desired use is beyond the tolerance levels

of adaptation then there is an affordability problem. There is an imbalance between one of the links of the triad: Building, Finance, and Use. This of course does not hold true if the income level exceeds the use demand. (Fig. 1.38)

A user can also utilize other input such as labor and bartering of services to meet their needs. Consider the case of a working mother-to-be. This particular mother has decided not to work for the first year of her child's life. In this case, the user's output or input must be replaced by other sources, adequate to meet the difference in lost income. Simultaneously, while this user is losing income, the use need is increasing. If this user lived in a community it may be possible for this mother to provide daycare services to other working parents within the community. They in turn would make up her lost input. Therefore, one user's input can be exchanged for another's output by incorporating labor and skill as potential input.

The Input/Output of Tenants

Tenants are occupants who either by choice or by lack of resources do not own a dwelling. These parties will be highly susceptible to fluctuations in the rental market.

Fluctuations in the market could cause a sudden rise in rents beyond what the user can afford could force moving and its associated expenses.

A tenant's input required from a building would be identical to the input of the owner-occupant. However, the capability of the user to meet that output would depend on speculative market forces. Thus the people whose use needs are more susceptible to fluctuations, because of their limited incomes have to contend with a speculative rental market. This further aggravates the difficulty a user has in accumulating equity. Should it not be possible for a user with limited income to gain equity through a lifetime necessity which one has to pay for anyway? Is the ability and right to amassing equity limited only to those who already have equity? (The strategy on Multiple Ownership and its ability to address this problem will be discussed in later sections.)

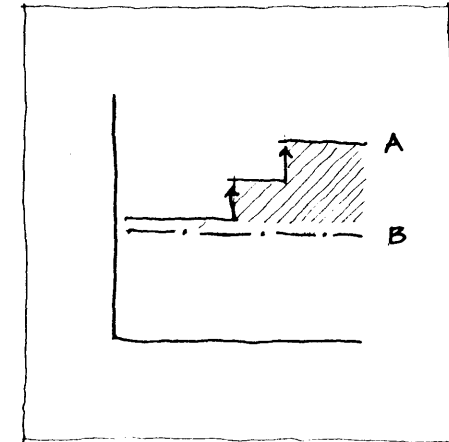

Fig. 1.38
Mismatch Between User's Needs and
Available Resources

A=Use Needs
B=Available Income

Tenant Output

The only output required of the tenant is rent. The tenant has one advantage in that they do not have to deal with the cost of maintenance and replacement, even though they may have to deal with the consequences of its neglect.

Non Occupant Input and Output

Essentially there are three kinds of non-occupants who can find use in a residential building. They include those people who do so for investment purposes, those who do so to achieve social and political goals, and those who do so for other miscellaneous reasons.

Investors

Investors may invest capital into buildings for several reasons: potential for speculative gain, sheltering income, and pleasure. If a building is seen as an investment, it will have to compete with investments in other markets. The rate of return on the investment in real estate must be equivalent to and competitive with other investments. Sources of input that a building can provide to investors include :

1. rental income
2. appreciation in value
3. deductions
 - a. deduction on interest
 - b. depreciation deductions
 - c. other tax credits
4. amortization/equity build up
5. expanded credit access (this is an indirect input)

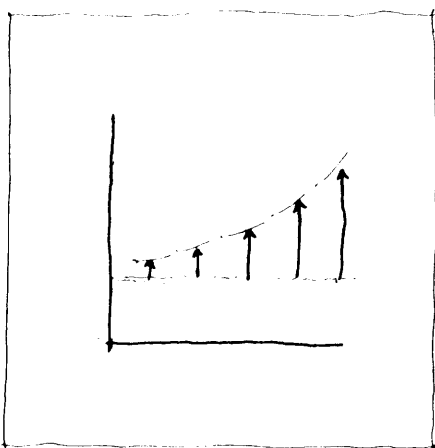

Fig.
Output Required by Investors = Return
on Investment

Output Required

Output required by investors depends upon the investment objectives of each group. In turn each investment group's requirements will have different time frames. Insurance companies, given their size, need not worry about short term fluctuations as smaller investors must, while small investors are extremely sensitive to what would be a small investment for an insurance company.

It is beyond the scope and intent of this thesis to classify all of the different investors and their input-output requirements and their respective tolerances to fluctuations, and will suffice to list the more prominent ones involved in the residential real estate market:

1. developer
2. insurance companies
3. investment trusts
4. syndicators
5. banks
6. community groups
7. small time investors
8. high income groups (doctors etc.)

Each group's objectives will differ and will affect an actor's output requirements. The timing or amount of an investor's output is depends on the amount of capital available to that user. Investment objectives will determine the output required and the timing of that output. For instance, a developer may have little equity and will therefore find people in higher tax brackets to contribute equity in turn for a portion of the tax deducitons, value, and income. The developer can by selling portions of a project, create equity without ever having had any initially.

Socially/Politically Motivated User:

This group of users' primary motivation is not the final output of the project or final cash-flow, (although that is a necessary constraint within which to work); instead it has a social or political origin.

In the case of community development groups and the more benevolent housing agencies, the major output is the production and supply of adequate and affordable housing to users deemed in need. In the case of political developers, (governments) their motive is to meet certain political objectives, although the intensity with which these objectives are pursued vary from political cycle to political cycle. The input required is the same as for all other user groups, except that in this case there is a wider array of building and funding sources available, including UDAG, Foundation grants, etc.

Summary of Socially

/Politically Motivated User:

OUTPUT include:

- meeting social and political goals
- equitable housing
- equity
- political objectives

INPUT include

- equity
- taxes
- grants/subsidies
- labor

THE FINANCE SYSTEM

Today, the financial intermediary is no longer the stronghold of banks. With recent deregulation policies in the banking industry many types of institutions have assumed the role of financial intermedy. They include:

- banks
- quasi governmental institutions
- insurance companies
- syndicates
- brokerage houses
- state public agencies

Each one of these institutions and actors have different loan types. Essentially a loan is a mechanism that regulates the input and output of the bank to the loanee to meet the input required by the building. The loan agreement states the timing of the input and output as well as their amount.

In the initial condition, output required by the bank will equal the entire loan amount, while the loan amount will be input from a loanee of "x" percentage of the total amount. This acts as a downpayment on the loan. In return the bank receives an interest payment on remaining debt and remaining payment on the loan itself for the term of the loan. Although it is not the intent of this thesis to go into all of the input and output of all of the financial intermediaries and their input and output, I do wish to expand on some of the other types of mechanisms available and how their input and output and timing can vary. They include:

- Fixed rate
- Variable Rate Mortgages
- Shared Appreciation Mortgages
- Graduated Payment Mortgages

Fixed Rate Mortgages

Fixed rate mortgages were once the most common mortgage type available. They

provide a constant payment schedule to the user. The user's output is the initial downpayment, and the regular schedule of payments. The bank's output is equal to the initial loan amount. The bank's input is equal to the repayment of the loan plus interest plus including the initial down payment.

This loan is not sensitive to fluctuations in external conditions over the lifetime of the loan. A measure of the return on the interest rate is typically three percent over initial inflation rate. In theory this assumes a constant rate of return to the bank over the lifetime of the loan, but the interest rates do fluctuate and place banks in precarious positions.

Since the banks are committed to the initial loan type and the initial interest rate, they have no protection against inflation. Very often in uncertain times, therefore, the premium the bank charges will be higher than 3% over inflation. (Fig. 1.39)

Variable Rate Mortgages

Variable rates are one means of building feedback mechanisms into the loan so that the rate of input will fluctuate with changes in external conditions such as fluctuating inflation rates. In this way, banks can afford to offer lower initial loan payments, since a bank's protection against future fluctuations would not have to be as great. This gives a bank a wider range of tolerance levels and a greater capability to withstand change and therefore protect its stability of the bank as an institution. (Fig. 1.40)

The input received by a user will begin to fluctuate with changes in the external market conditions, it will but simultaneously be tempered by the limits of the loan agreement, such as a maximum increase in payment when interest rates fluctuate.

Graduated Payment Mortgages

A graduated payment mortgage is a loan mechanism intended for individuals who do not currently have enough income to meet their use needs but are reasonably certain that their income will be sufficient in the very near future to meet those needs.

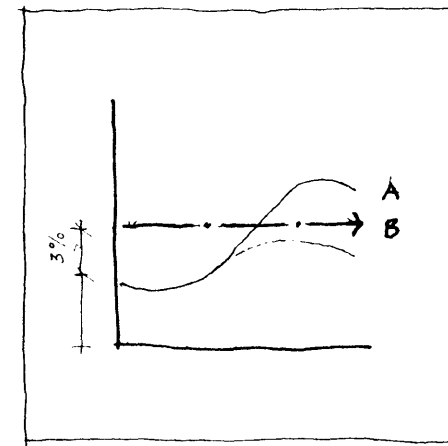

Fig. 1.39
Std. Mortgage vs. Inflation

A=Stand Mortgage Payments
B=Inflation

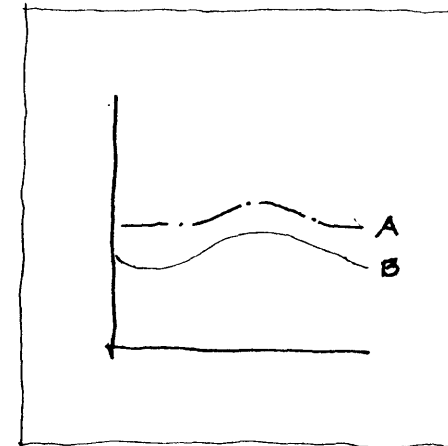

Fig. 1.40
Variable Rate Mortgage Adjusting to Inflation

A=Variable Mortgage Payment
B=Inflation

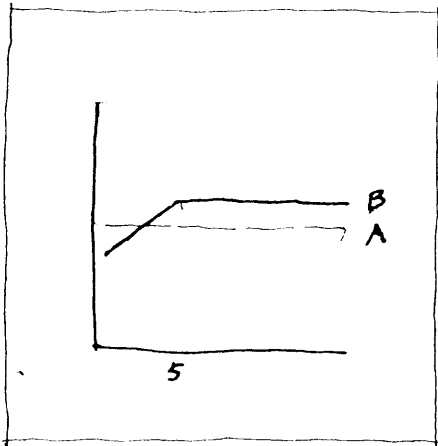

Fig. 1.41
Graduated Payment Mortgage

A=Stand. Mortgage Inst.
B=Graduated Payment Mortgage

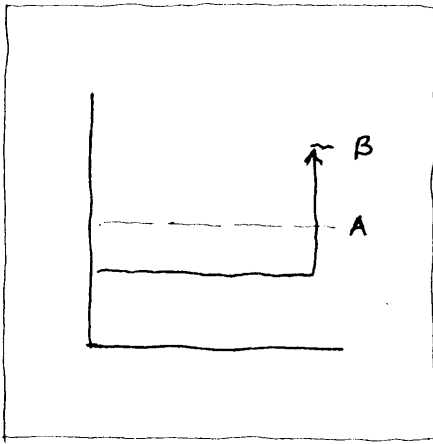

Fig. 1.42
Shared Appreciation Mortgage

A=Stand. Mortgage Inst.
B=Shared Appreciation Mortgage

Thus the bank allows a lower initial repayment schedule than the typical standard mortgage. The bank then accelerates the payment schedule for the next five to seven years, at which point the payments are actually higher than the standard mortgage type. The discounted value of the increased payments will make up the difference in the value of the lower payments. (Fig. 1.41)

Shared Appreciation Mortgages

Shared appreciation mortgages are for the user who does not have enough initial capital yet requires a certain use space. Therefore, the bank goes into the loan as a partial investor. In return for accepting lower initial payments at a reduced interest rate, the bank will accept in exchange a percentage of the appreciated value of an investment upon sale. Thus the appreciated value will be a future value which when discounted over the lifetime of a loan equals the lost interest.

Without mentioning all the institutions and loan mechanisms available in today's market, it should be noted that every actor and every financial intermediary can regulate their own input and output over the lifetime of a loan by whatever terms of agreements they wish to establish between themselves, so long as they remain within the boundaries of the law. (Fig. 1.42)

CHARTING THE INPUT AND OUTPUT OF DIFFERENT SYSTEMS

One way of determining whether a building-use-finance system will be stable is to chart the common input and output of two systems. I will look briefly at the input and output of some of the critical links between the following systems:

- Building-Use
- Use-Finance
- Building-Finance

Building-Use

In this case we simply chart the use input or building space required by a user and the use

output provided by a building. Each building has a different capacity to supply initial output and changing output over time. If a building consists of ten 10 ft. x 10 ft. rooms all made of solid concrete walls for instance, we may assume that it could not accommodate as wide a range of activities over its lifetime as a wood building with varying room sizes. The use needs will depend on the input required of a user and their tolerance to change over time. A family may need an extra room for a particular use, but it may not be entirely necessary and they may be able to live without it. Therefore, if the house cannot accommodate that use, they will most likely remain in that house and do without the extra room. However, if a certain type of space requirement which is critical to the user, (for instance, a child is born and requires space, or a long-lost family member joins the family for an extended stay, or a family member needs to work at home, etc.) and the necessary change is beyond the capacity of the building, then the user may have to find a different building which can meet those needs. (Fig. 1.43-1.45)

Use-Finance

The most critical input/output link between the use systems and the finance systems deals with the output required of a user, namely money to repay a loan. A second and important concern is the tolerance level of the financing mechanism to meet fluctuations in external conditions, which can include fluctuations in the financial markets as well as the user's ability to repay the loan on schedule.

The financial instruments, by definition, must be stable to withstand changes in the external constraints of the financial world. The loan term sets the conditions by which the internal system can regulate itself to changing external conditions. Its tolerance of change is determined at the outset of the loan.

As discussed in the section on mortgage instruments, there are several different mortgage types, all of which have their own internal constructs, and each of which has different

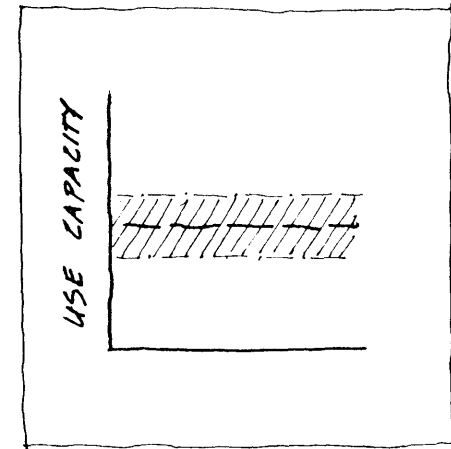

Fig. 1.43
A Building's Capacity To Meet Changing Needs

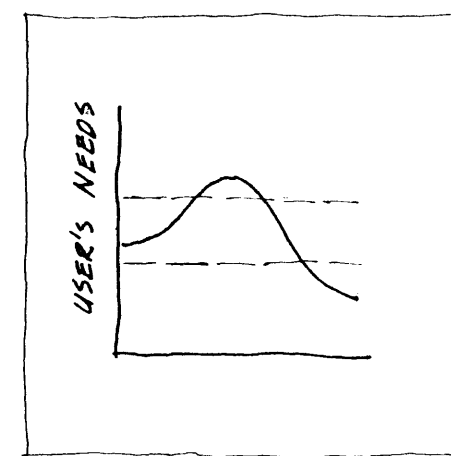

Fig. 1.44
A User's Needs Over a Lifetime

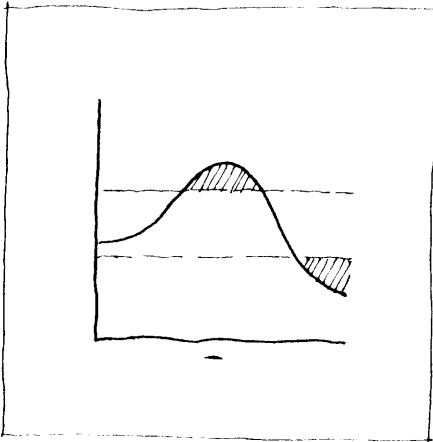

Fig. 1.45
A User's Needs vs. the Building's
Capacity To Accomodate Them
(this depends on societal and User's
norm)

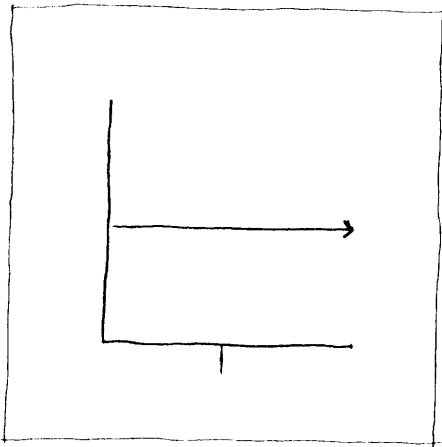

Fig. 1.46
Input Required By A Bank using a
Standard Mortgage

reactions to external conditions. Those external conditions include such things as inflation, supply of money, demand on debt, demand on credit, etc.

Therefore, once a loan is made, we can chart the actual or projected output required by a user to meet the requirements of the loan. This is done by superimposing the input and output of a loan on the income available to a user. (Fig. 1.46-1.48)

Building-Finance

Most buildings are just financed in one mortgage term. The terms typically correlate to the perceived lifetime of a building which is equal to about 25-40 years in residential construction. However, what are the consequences of having mortgage payments which do not correlate with the variable lifetimes of building components?

Consider the case of a 15 year old house which has recently been bought by a family. This family has just enough resources available to meet the payments required in their initial condition. To their surprise, in the sixteenth year of the building's life, the roof surface begins showing signs of failure. They delay replacing it because they do not have enough capital to pay for repairs. After a fierce hail storm, a major part of the roof systems fails all together. Not only were the roofing surfaces in need of repair, but now damage has occurred to the sheathing and exposed interior surfaces.

This example is intended to show that the total costs of a building may not necessarily be as continuous as financing payments indicate, especially in later years when the accumulated effect of multiple system failures becomes apparent. (Fig. 1.49-1.51)

What becomes apparent is that the total cost of ownership goes beyond the initial mortgage payment. Replacement costs, operation costs, etc. can be a significant portion of total building expenditures. Therefore, for those users whose tolerance levels cannot buttress severe changes in the total cost of housing, it is especially important to understand a building's lifetime behavior. It becomes a question of speculating on the potential costs of a building are over its lifetime and adjusting payments accordingly.

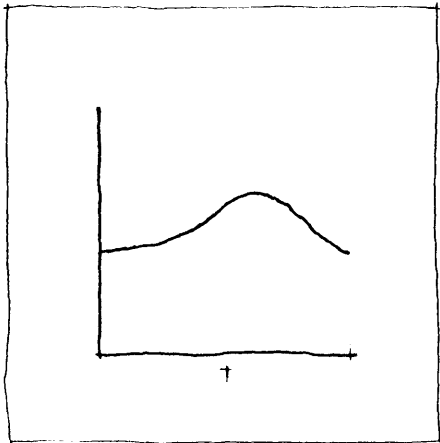

Fig. 1.47
A Families Available Income Over Time

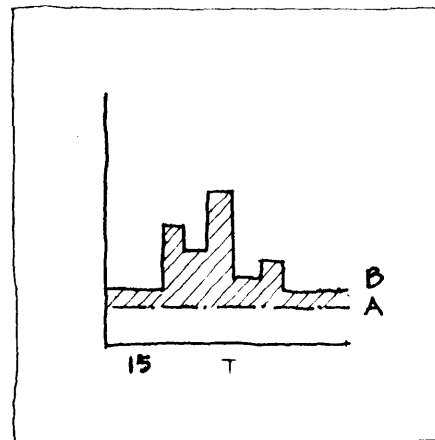

Fig. 1.49
Input Required by Building vs. Std. Mortgage
A=Standard Mortgage
B=Maintenance & Replacement

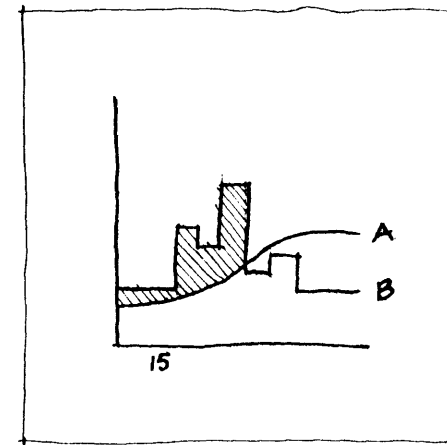

Fig. 1.51
Building Input vs. User's Output

A=Building Required Input
B= User's Available Income

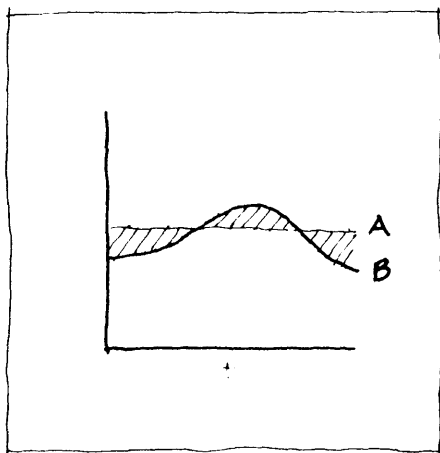

Fig. 1.48
Available Income vs. Input Required by Bank

A=Input Required by Bank
B=Available Income

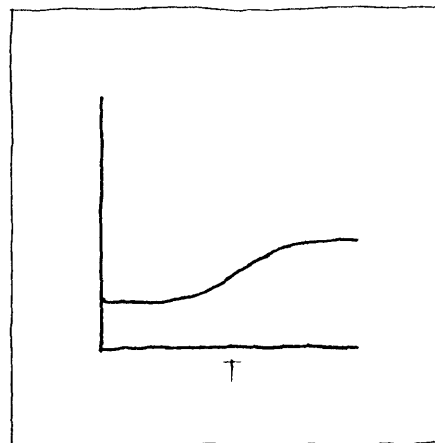

Fig. 1.50
The User's Available Resources

SYNTHESIS

Synthesis requires a means, an order; what are the parameters of this new synthesis. The order should be able to address the original objectives which could be broadly categorized under:

- 1.) Building-use; a building must have a good fit with a building's capacity to provide use as well as the extended probability of meeting changing conditions.
- 2) Use-finance; a better way of allowing users to meet the financial demands of a building.
- 3) Use-finance; a more optimum financing mechanism which is able to meet the the input requirements of a building and the output capacity of the users.

All of the above should apply both initially and over time. Adding the temporal factor indicates that a building, financial, use system must be able to be both flexible and adaptive to change as well as being a stable system over time. It is a structure and order which has seemingly contradictory goals: A structure which is both permanent and yet adaptive, affordable but usable, continuous, yet variable.

There are many many ways of structuring such an order, and I do not wish to presume to understand the nature of that order. I will only speak of several strategies which either through the manipulation of one of the systems, building, finance or use, and their interrelationships we can begin to meet the above objectives. Developing a comprehensive understanding of how the environment can be structured so as to allow for variability in all systems, is beyond the scope of this thesis. however I will beg to offer a description of how the three systems can be structured and integrated.

Principles and Strategies

If we accept the notion that buildings are aggregations of decomposable systems, I hope to demonstrate the five strategies that can be employed to meet the original objective, to make housing more affordable to users initially and over time.

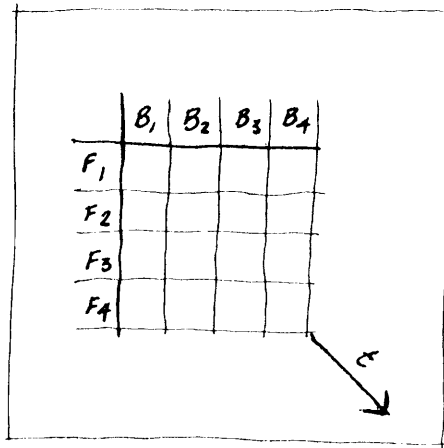

Fig. 1.52
Multiple Financing

F1 = 10 years
F2 = 15 years
F3 = 30 years
F4 = 60 years

Some of the five strategies are already being practiced in the real world in an intentional or ad hoc fashion. My intent is to bind the benefits of each of the methods already used into a more coherent conceptual structure which will simultaneously incorporate the notions of decomposable buildings. In fact, by using the notion of decomposability, the true potential of the strategies can be fully realized.

The strategies basically use two principles either in isolation or in combination. They are:

- 1) A building can have multiple users with different use intentions.
- 2) Each system of building components can be financed separately.
- 3) A building's pattern of construction financing, and operation can be temporally manipulated.

The five strategies derived from these principles include:

- Multiple Financing
- Multiple Ownership
- Phased Construction
- Income Supplementing
- Alternative Financing

1. Multiple Financing:

A building is split up into groups of nearly decomposable components. They are financed according to a term equal to the lifetime of a component. This allows for a more predictable and continuous pattern of input required over the building's lifetime and a more orderly way of financing it. However, the initial period costs will be higher than the standard mortgage types, since the terms of the loan vary.(Fig. 1.52)

2. Split Ownership

Split ownership allows for a building to have multiple users, all of which have different needs and resources available to them. The ultimate aim of this mechanism would be to synchronize the building components' useful output with those users who are in need of it, as well as to meet the resources available to the users. (Fig. 1.53)

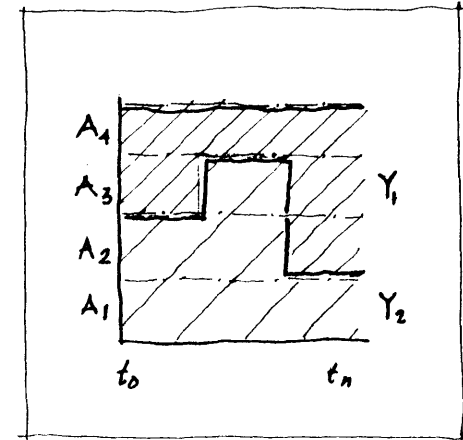

Fig. 1.53
Multiple Ownership over Time
Y1 = Occupant-User
Y2 = Non-Occupant-User

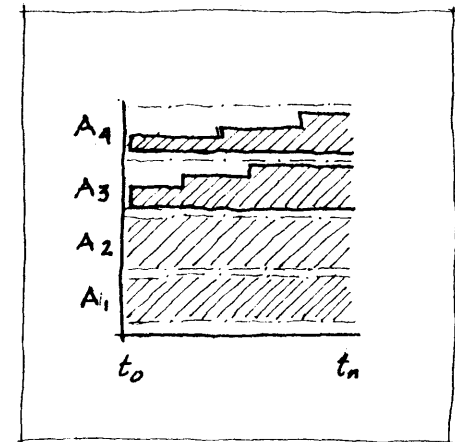

Fig. 1.54
Phased Construction
Building decomposable system (A3 & A4) over time

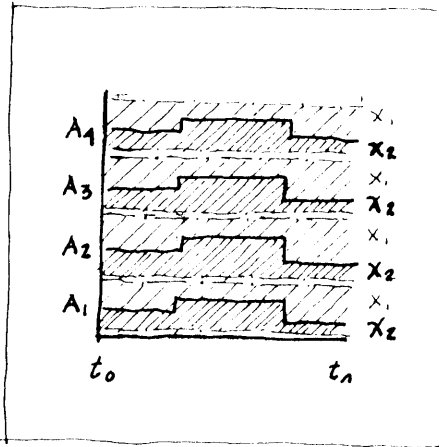

Fig. 1.55
Income Supplementing
The Physical Space Alters as the
owner's Needs Change
X1 = tenant
X2 = owner

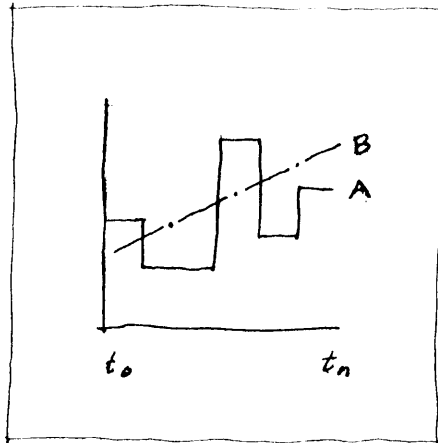

Fig. 1.56
Flexible Financing-Equalizing payments
over time.
A=Building Input/Output
B=Equalized Payments

As the diagrams indicate the portion that the users own in a building can change depending on the internal constraints of that user group.

3. Phased Construction

Phased construction is a way to recognize the reality that an entire building may not be affordable to a user initially and therefore to build the faster depreciating decomposable systems commensurate with the resources available. So as long as a building meets the minimum needs of the user and the potential exists for future resources to be present (labor included), this can be considered a viable alternative. (Fig. 1.54)

4. Income Supplementing

Simply stated, this is based on the prototype of the two-family house. One user group is an owner occupant who rents to the second user group part of the building. Supplementary income provided by the tenants allows the initial user to meet the overall input required by the building. If one designed a decomposable building which could contract or expand as the needs of the owner occupant and tenant changed through the lifetime of a building, that building may be deemed more suitable for a longer period to that user. (Fig. 1.55)

It should be noted however that this strategy requires a higher initial payment and therefore higher initial resources on the part of the user.

5. Flexible Financing

Flexible financing explores the possibilities of considering all the input and output of a building over the term of intended use and calculates a mortgage payment accordingly. Over the lifetime of a financing mechanism, predictions about the behavior of the building could be compared with actual behavioral characteristics and subsequently could be monitored and adjusted accordingly. Because a building has a wide array of input and output over its lifetime, much of it, such as return on sale, which doesn't occur until later years, could be applied towards the initial hardship years. (Fig. 1.56)

PART 2

DESCRIPTION OF THE MODEL

I have attempted to model the behavior of the input and output of a townhouse, its users, and the financial mechanisms over a forty year period. Five strategies are demonstrated which allow users a greater chance of meeting the required input and output of each system.

The larger intent of creating this model has been to demonstrate the realization of the conceptual framework. It is not the intent to make absolute statements on the financial consequences of each strategy's results as calculated by this model and its data base. The second objective of this model is to create a model which was capable of providing a tool for further study.

The model has several strengths:

- Its functions and operations are based on real processes.
- The possibility exists to add further realistic operational features to this model.
- It starts from a position of using real data and real figures.

The weaknesses of the model are:

- Its data base is incomplete.
- Its operational features are limited.

Some lifecycle data was not available or difficult to compile. Given the limits of time, it was not possible to make complete and detailed analysis for initial costs of each building component. In regard to some of the functions and operations, some of the overriding and simplifying assumptions pose questions on whether the model deviated too far from reality. For instance, although the capacity existed to model moving patterns and resultant proceeds from sale, the consequences of replicating a sale every several years and the affects it would have on calculating new financial instruments for other parties and users were not included. Other simplifying notions such as constant space needs were used because of time limitations. To develop a model which could both chart and monitor changes in space needs and carry them out on them out on the building as dictated by users' lifecycles would have required an extensive data base. Other

simplifying assumptions, such as constant income levels were done to eliminate the need for a data base containing differential tax rates, and to allow one to distill information from the results without necessarily having to deal with the extra confusion of a varying income level.

Although the ultimate goal in the future may be to create a model which can replicate a highly realistic and adaptive construct of the economic lives of buildings and users, even a limited tool such as the one that I have developed can prove useful in monitoring and examining the behavior of the strategies compared to our typical arrangements.

The first part of this thesis emphasized the importance of the relationship between the building, finance, and user systems. What is apparent is that the more physical the system is the more deterministic it is and therefore easier to model. In the case of a system which has the human element as in the case of user systems here, modeling becomes a purely speculative affair. Therefore, there is no attempt to model the users' lifetime behavior; the only attempt is to build into the building the capacity for the lifecycles to be simulated as each case demands. To incorporate every user lifecycle pattern and every financial mechanism available, would be cumbersome.

Therefore, I have extensively modeled the building itself and all of its input and output while fixing the number of variations and possibilities in the financial and user systems. For instance, I use only one financial instrument, (a fixed rate mortgage) on all the nearly decomposable systems, while only altering the term of the loan. Another major simplifying assumption was that the user-occupant's behavior is constant. That is to say, the user-occupants spatial needs are constant, and available financial resources are constant relative to inflation over the entire forty year period. This was done because one of the intentions of this model is first to demonstrate the behavior of the building once it was decomposed, and therefore a simplifying assumption was necessary to prevent any obfuscation created by the superimposition of idiosyncratic user lifecycle behaviors.

What the Model Does

The model acts as a means of generating all of the potential and actual financial input and output of a building over a forty year period. The primary lifecycle input are:

- initial costs
- maintenance
- operation
- energy
- finance
- replacement costs

All of the building's potential output, such as the built up equity, the value of the interest deductions, depreciation deductions, and potential rental income, are tabulated for each building component. All of this input and output are calculated and categorized according to groups of 60, 30, 15, and 10 year lifecycle groups.

A building made of components will have a different actual input and output depending upon which actors are acting upon them. An investor can get different deductions than a user-occupant. Therefore, an important aspect of this model allows different users to act on the components according to the precepts of each strategy. Since we know that our primary objective is to make housing more affordable to the user-occupant one given is that the owner-occupant's position is always maximized relative to other users.

The final part of this model uses the strategies to establish the relationships between the users so that each user group will be able to have their input and output matched initially and over time. I was unable to introduce multiple financial instruments which could be plugged-in for different users because of time limits.

The Technicalities of the Model

The economic model was created on an Apple Macintosh 512. The software applications used were both by MicroSoft Inc. Multiplan was used as a spreadsheet, and the McChart application was used to produce graphic data.

The economic model itself consists of nine separate but interlinked spread sheets. Each spread sheet has specific functions, which are to produce a set of calculations and then to funnel

that information to another spreadsheet and its functions. Essentially there are three levels in this model:

1. General Data
2. Lifecycle Costs Resource Generators
3. Synthesizer

Level One: General Data

There are two general data spreadsheets which calculate the initial costs and the initial lifecycle costs of a project which can in turn be projected over time. The initial costs include construction costs, development costs, management overhead, and profit. The lifecycle costs include such things as replacement, maintenance, operation costs, etc. Both the initial costs and the lifecycle costs are broken down by cost per component. These in turn are further fragmented into labor, material, and energy costs. The critical data generated in the initial stage of this project is then directed toward the appropriate spreadsheets in level two which further elaborate on the total costs of the system over the lifetime of the building.

Level Two: Lifecycle Generators.

Essentially this level is split up into five spread sheets, four of which generate all of the potential input and output of each family of components over their lifetime. One spreadsheet on this level is exclusively created to plug in an occupant group, their use needs and the financial resources available to them over their lifetime.

The critical input and output generated is then in turn funneled into the level three spreadsheets. The four subcategories and spread sheets produce all of the potential financial input and output of each component. This in turn is pumped into the synthesizer and into level three, along with the projected income streams of the occupant.

Level Three: The Synthesizer

The synthesizer in its dormant state assembles all of the critical potential input and output of each component, as well as the financial resources available to the user.

THE MODEL

Diagram of the Model

The Model is structured in three parts: The Data Compiler, The Lifecycle Generators, and the Synthesizer. Each level processes data and then funnels critical data to the next level.

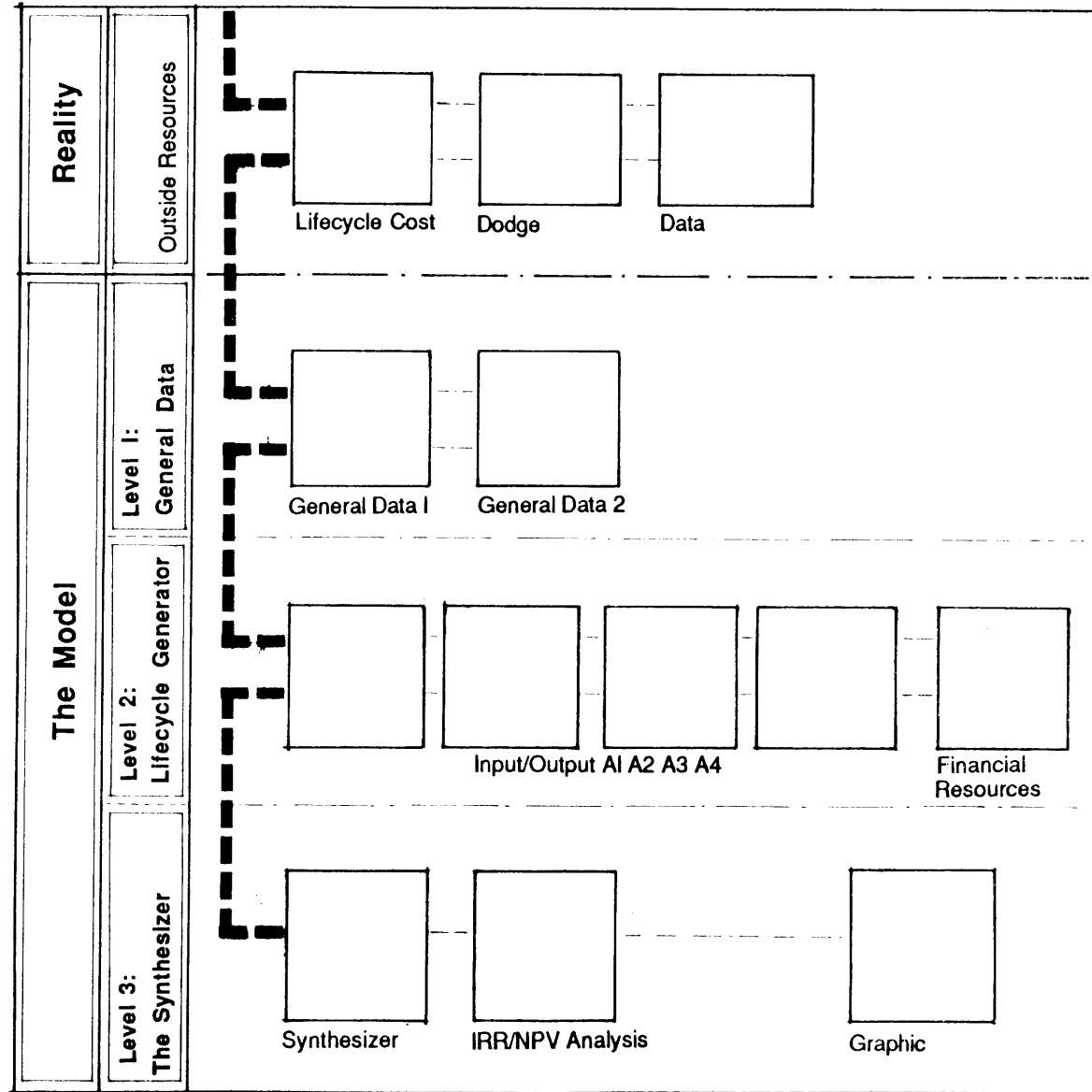

This model in its dormant state was taken and copied on to five other discs which became the basis for five different strategies. Since the potential input and output of the components over the lifetimes is known and it is also known that the required input cannot be met by the occupant, a strategy to fill the "affordability gap" (represented by the gap in the building, finance, and use input output graphs), must be developed using either the devices of "multiusership" and/or "temporal" manipulations. Each strategy either introduces other users or fixes certain payment patterns or construction phases. First let us review the major assumptions that went into this model and then go into a more detailed analysis of the reasons why these prototypical spread sheets and their sources of data were structured as they were .

° **MAJOR ASSUMPTIONS: Starting Points**

1. A building is composed of nearly decomposable subsystems which in turn can be split up in the building, design, financing, and ownership mechanisms.
2. The term of this study is 40 years, in order to demonstrate the behavior of longer life components, the lifecycles of user needs, and user' available resources.
3. For this study I have used one standard townhouse as the building which undergoes no physical design transformations other than the replacement of building parts.
4. The user occupants' needs are constant over time.
5. The users' financial resources are constant over time.
6. The lifecycle costs of this model will occur in regular and continuous fashion.
 - a. replacement costs occur when the useful lifetime is terminated
 - b. maintenance and operation costs are linearly applied
7. Outside users' input and output is variable. That is, in all strategies the occupant-user input and output is fixed and optimized according to each strategy's intent.
8. The inflation rate is constant at 6 percent. All costs and incomes are calculated at future values using six percent as a discount rate.

9. Fixed rate mortgages are used in all strategies except the last one (alternative financing). The only variables in the mortgages are their terms. Only in the normal model is the mortgage term fixed for all components.
10. Each component is depreciated for tax purposes at a rate equal to the lifetime or usable lifetime of that component, except in the first case where the depreciation cycle is equal to 18 years.
11. The tax rate for all of the user-occupants is 25% over the lifetime, and for investors, the tax rate is 50%.

DESCRIPTION OF EACH SPREADSHEET

Level One: General Data

• General Data .1

General Data .1 and General Data .2 provide the base information for all other spreadsheets. Data is taken from outside resources and compiled into these two spreadsheets. As my source of data, I have used primarily material provided by the Harvard Business School case study entitled, Stanford Court Condominiums, 9-379-066. The actual story behind the case study is unimportant. My only purpose for choosing this study was to provide a starting point for data, as well as a project which was highly adaptable to the concept of nearly decomposable components. The project itself is a series of townhouses developed in Houston. The spaces included in the program are as follows:

- entry
- dining room
- kitchen
- family room
- master bedroom
- bedroom
- two full baths

Total floor area on this project is equal to 1350 square feet. The units are rather nondescript townhouses two stories high which falls between bearing walls occurring every eighteen feet. The cost per unit in 1978 was equal to \$51,000. I projected those costs and projected them forward to 1983 assuming an inflation rate of 6% per year, or a total increase of 140% over the initial cost. The 1983 costs were chosen because that was the year in which common data could be found for lifecycle data and initial cost data. Thus the 1983 costs of the unit was equal to \$71,000 or \$53 per square foot.

Total non-construction costs derived from the case study are equal to 23.53% of total costs. Non-construction costs included management, development, land costs, financing charges, and profit for developers. The 23.53 % non-construction costs costs are carried over to each component group;

• **General Data .2**

General.Data.2 elaborates on the previous spread sheet. A more extensive derivation of lifecycle costs and initial costs are calculated. First, the building is broken down into each component group and they are classified according to their useful lifetimes. (See appendix)

Each component's initial lifecycle costs are taken from the lifecycle data in Della' Iso and Kirk 1983 book entitled: Lifecycle Cost Data. Unit costs taken from the source are multiplied by the number of units per component found in the actual building studied. However, I was unable to obtain all of the lifecycle cost data especially for such item as furniture where seemingly little data exists.

The initial lifecycle costs were then broken down into labor and material divisions. It became possible to calculate what the labor and material costs were for each component and each nearly decomposable subgroup.

According to the initial calculations it appears that the portion of costs directed toward lifecycle costs are significantly higher for the A.3 family of components (interiors). The reason for this is that such labor-intensive tasks as cleaning, painting, filling, etc. take place in this

component group. It is clear that this is the portion of the building that bears the most wear and tear. It is also an interesting to note is that this type of labor requires the least skill and therefore could be a source of great cost reduction of public or private developers who could transfer the ownership and responsibility of the interior (A.3) to the user - occupant. (See section on Multi-Users.)

-Total Initial Costs

The basis for total initial costs is taken from the case study as previously explained. Given that only diagrammatic plans were provided in the case study the pricing of each component and subcomponent became an impossible task. Therefore I surveyed the Dodge and Means Cost catalogs which estimate average costs according to building groups and components for similar types of buildings . I then interpolated the costs per component group from both of these sources and arrived at the breakdown per component group. It is interesting to note that although the breakdown by category is different for each source, a general division between the A1 & A2 versus A3 & A4 is rather consistent around 50%.

The Processing of Potential and Actual Input/output

1. The Building's Total Potential Input/Output
- 2 Total Potential Input/Output/Component
3. User Acting on the Data (occurs in Level 3 synthesizer)
4. Actual Input / Output / Component/User

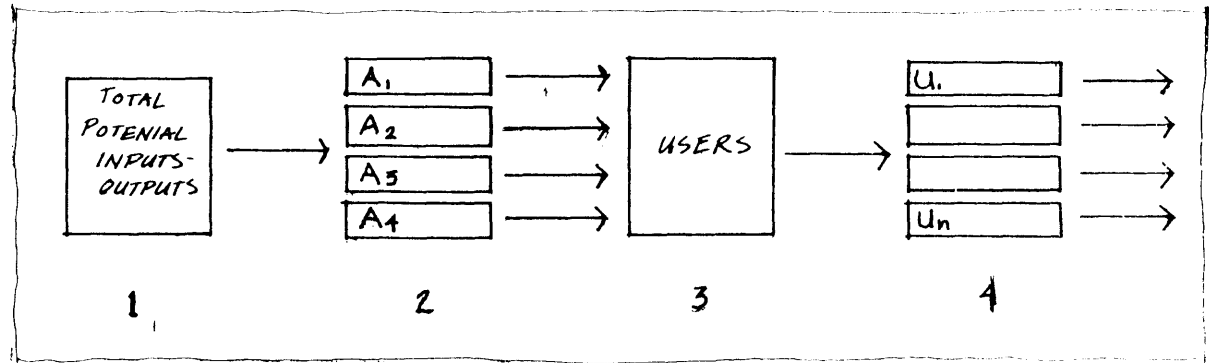

LEVEL TWO: Lifetime Input/Output Generators

The intent of the five lifetime cost generators is to take the initial cost and the initial lifecycle cost provided in General Data .1 and General Data .2 and to project them over the entire life of the building. Furthermore, this section will calculate all the input and output for each component group. And finally, the intent of this level is to establish the lifecycle earning pattern for the occupant.

• Spreadsheets A1...A4

The total initial costs and the tabulated lifecycle costs are taken from level one spreadsheets and projected over the entire lifetime of each component. From these few bits of information, the entire lifecycle costs of a building can be generated. These costs include:

- Financing
 - interest cost
 - debt
- Lifecycle costs
- Potential Deductions
 - deductions on interest
 - deductions on appreciation
- Potential Rental Income
- Potential Value Increase

- Financing Costs**

Financing costs are calculated by using the standard mortgage instrument. The term of the lifetime of the loan is either thirty years or equal to the lifetime of the component. The interest rate is equal to 12.5%. Downpayment equals ten percent and occurs not only in initial years but also in years of replacement since it is assumed that replacement costs need to be financed as well in all cases except the base-line. The replacement costs are calculated by applying the original costs times the accumulated inflation over the interim.

-Interest: The interest is calculated for the entire lifetime of the loan

-Lifecycle : the lifecycle costs for each component are taken and tabulated as one cost for an entire decomposable system and lifetime group.

-Tax Deductions

-Interest Deductions - the interest deduction is equal to the value of interest that year.

-Depreciation Deductions - the entire initial costs of each component group are depreciated over either one of two terms; the IRS set depreciation terms (used only in the baseline), or depreciation cycles equal to the useful life of each component.

-Increased values: It is assumed that building and its nearly decomposable systems appreciate at a certain rate. That rate is equal to the inflation rate. Although one can place a factor on this escalation rate to alter its behavior relative to the inflation rate, I have chosen to make them identical in order to prevent any exaggerated affects. The increase in the total building value is split up in proportion to the initial value of each nearly decomposable system. Therefore every depreciable element has potential to create value.

-Rent: It is assumed that the building or any of its components can be rented. According to the case study, the market value of rent in 1983 would be \$5,220. Therefore, if someone were renting a component which comprised 25% of total initial costs, the rental rate for that component would be equal to 25% of that component's cost. There is also a rental increase factor which one can apply to initial rental rate. This was done because if one is renting an interior, one is also renting the land on which the interior rests on. The factor allows for any such adjustments.

To summarize these four spreadsheets, the total input for each component is equal to financing costs plus lifecycle costs. The total potential output is equal to tax deductions, plus increased value, plus rental income.

•Financial Resource Spread Sheet.

There are three types of financial resources available in this model:

1. owner-occupants
2. tenants
3. non-occupant investors

-Owner-occupants

In this model the only income that is fixed is the owner-occupants'. The income level is set at a constant level of \$16,000 per year initially. The income then rises each year according to the inflation rate. Although the uniform rise may not be very "realistic" one of the intentions of the study is to show that the behavior of the building first. To create discontinuities in the income streams would confuse our ability to observe the behavior of the building system in isolation. However, it should be noted that by implication the model has the capacity to adapt to different user lifecycle patterns.

The other output that is available to the user is accumulated wealth. I have assumed that each family has an initial wealth base of \$10,000 of which 25% could be used as a downpayment over the lifetime of the building.

The model, though, does have the capacity to create variable resources lifecycles. One can input different members in one user group at any time of the building's lifecycle. It is also possible to interject the added income additional occupants may bring with them. So, if a grandmother for instance, moves into a house in year "X" one can assume that 25% of her income could be contributed to the input required by the building.

The more realistic income chart of a couple, both of whom are working may be useful to look at. Assume that after five years of cohabitation one of them loses their job or is with child, or decides to take two years off to write a book. This means that there will be a discontinuity in the income stream which could affect their ability to meet the output required by the building. Such an income stream could be superimposed over the input required by the building and then

transformed by means of one of the strategies to test whether or not the differences in input and output could be minimized or resolved.

-Occupant tenants:

This resource is only used in the "supplementary income" strategy. In this case, the \$73,000 house has been expanded into a \$100,000 house to meet the spatial requirements of both the occupant and the owner occupant and tenant occupant. Thus the tenant lives in the unit and provides rent which in turn is transferred as an input into the building.

-Non-Occupant User: Investors

Investors are those parties who invest in parts of the building over the building's lifetime. Since the amount a user-occupant can afford is fixed, the amount that an investor must pay (or receives in return) varies with the fluctuations in the building's input requirements. (It is assumed that all investors are in a fifty percent tax bracket.)

LEVEL THREE: The Synthesizer

• The Synthesizer

Level three has the spreadsheets that compile all of the critical input and output of each nearly decomposable system over the lifetime of the building. It also compiles all of the available financial resources. Strategies are then applied by manipulating and fixing equations.

As previously stated, each output is dormant until acted upon by different actors. These actors' policies are determined by the internal mechanisms of each strategy. What this section provides is the actual input and output per component and the consequences of each to each user.

• IRR/NPV Analysis:

This spreadsheet is capable of taking in input and output streams of different actors from the synthesizer and calculating returns by either using internal rates of return or net present value. This spreadsheets capacity was however not utilized in evaluating this model.

PART 3

THE BASE LINE MODEL:

The Purpose: The purpose of this model is to describe how the model behaves in its dormant state, so as to provide a useful comparison for other strategies.

The base line model attempts to replicate a realistic case within the limits of the model. Therefore, the house is financed by a 30 year loan, and each replacement cost is paid for in its entirety, without the benefit of financing.

Superimposed on the building's behavior are the financial resources of the median family. Together these two curves, the curves produced by the output demanded by the building and the income available will allow us to determine the affordability gap over time.

The Assumptions

- The term of study is forty years.
- The building is owned and used by one user over the lifetime of the building
- Replacements are not financed separately; instead they are paid for in whole at the time of occurrence.
- The income level of the users is constant
- The space needs are constant
- After thirty years the building is paid for in its entirety (because of the thirty year mortgage).
- After the building is paid for the only costs will be maintenance, operation, and replacement costs.
- All costs and values rise with an inflation rate of 6% per year; thus a replacement cost will be equal to the future value of the initial cost per component minus the salvage value.

Results/Analysis

The most telling aspect of the base line model model in the first ten years is that there is inadequate input to meet the required output of the building. It is only in the tenth year that this family in the base line model can begin to afford the modeled house. This is largely due to

income being inflated by inflation. In the tenth year the user can only afford a house at ten year old prices.

In the first year the initial condition is quite dismal for the perspective home owner. The user can only afford to qualify for 1/2 of the total mortgage amount required.

Long term Analysis

Assuming that this family could afford this house after ten years, they would soon encounter added financial problems. Certain parts of the building would have to be replaced within several years of the termination of their useful life. First the furniture and appliances would show signs of decay. Soon after the doorways, kitchen units, glass doors, closets, parts of walls, etc. would require attention. The payment of these repairs or replacements could be in a lump sum fee or could be spread out over several years. In this model they are represented as lump sum fees, thus in the fifteenth year the entire A.3 component system is replaced, even though in reality the replacement and payment of these components would be clustered around the fifteenth year without necessarily occurring simultaneously in the fifteenth year.

Also noteworthy are the large humps in the graphs occurring in the thirtieth year. This is because the ten, fifteen, and thirty year systems all require repair in the same year. Again the payments of all these replacements would not actually occur as represented in the graph. However, what is most noteworthy is that the area of the displacement is greater than the area of resources available within five years of the thirtieth year. One wonders about this fact and the correlation and demise of neighborhoods that tend to occur in thirty year cycles, as in the case of the American suburb.

Issues and Problems

As previously mentioned one of the problems with this model is that it assumes one user owns the building over its entire life. Furthermore, the users' income and needs do not change. Another problem with this model is its incapacity to replicate moving. People will move to realize

appreciated value and equity in their houses. One can jump to more expensive housing in this manner.

Most noteworthy, was the pattern of repairs and replacements required by the building. For instance, if a user buys into a house in the sixteenth year of the lifetime of that house, the user may soon encounter unforeseen costs resulting from the replacement and extensive repair the faster depreciating components require.

Matrix for the Base-Line Model

BI = One Building
UI = One User
FI = One Financing Scheme

$$\left[\begin{array}{c} B_1 \\ \end{array} \right] \times \left[\begin{array}{c} U_1 \\ \end{array} \right] \times \left[\begin{array}{c} F_1 \\ \end{array} \right]$$

BASELINE MODEL:

Total Input Required vs. Available Income over 40 years.

This graph shows all the input required over the lifetime of a building and the user's income available to pay for those input. The input required are broken down by component group.

What is interesting to note is that although the curves follow each other rather closely in the initial years, the combined affect of the replacements occuring in similar years is problematic.

One wonder about the correlation between the behavior exhibited in the graph around the thirtieth year and the lifecycles of neighborhoods.

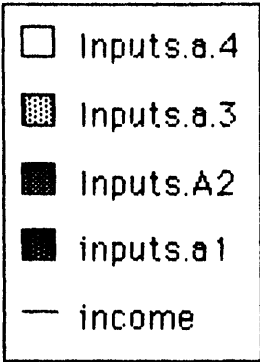
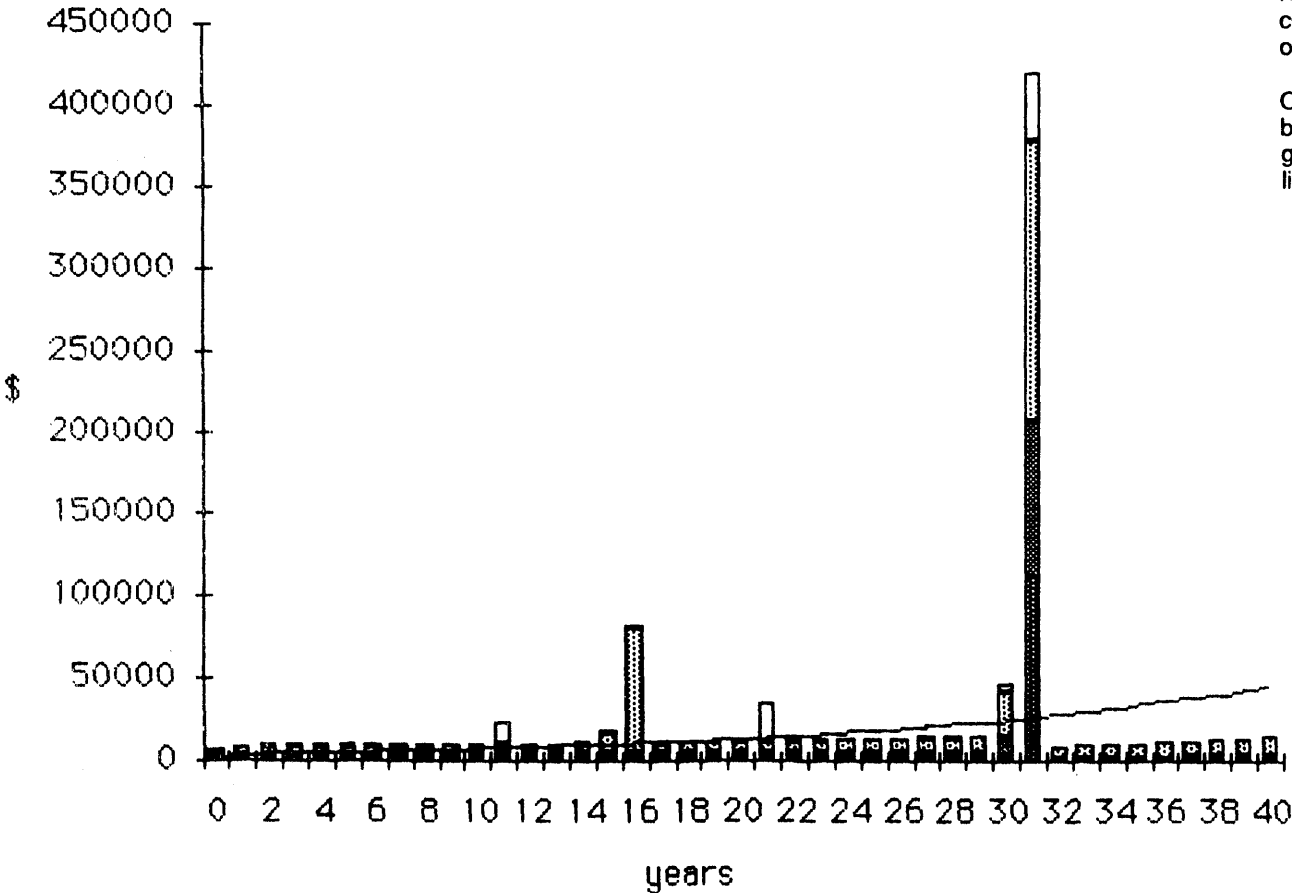

Total Input required vs. Available Income in the first Ten Years.

A closer look at the actual input required by the building during its first ten years indicates a significant disparity between the available income and the input required. To afford the house used in the model during the initial years would require an income of \$9,300 / YR.

As inflation rises at a rate of 6%/ Year it allow the user to "catch up" with the payments required since the mortgage rate is fixed, and all that would rise is the maintenance and operation costs.

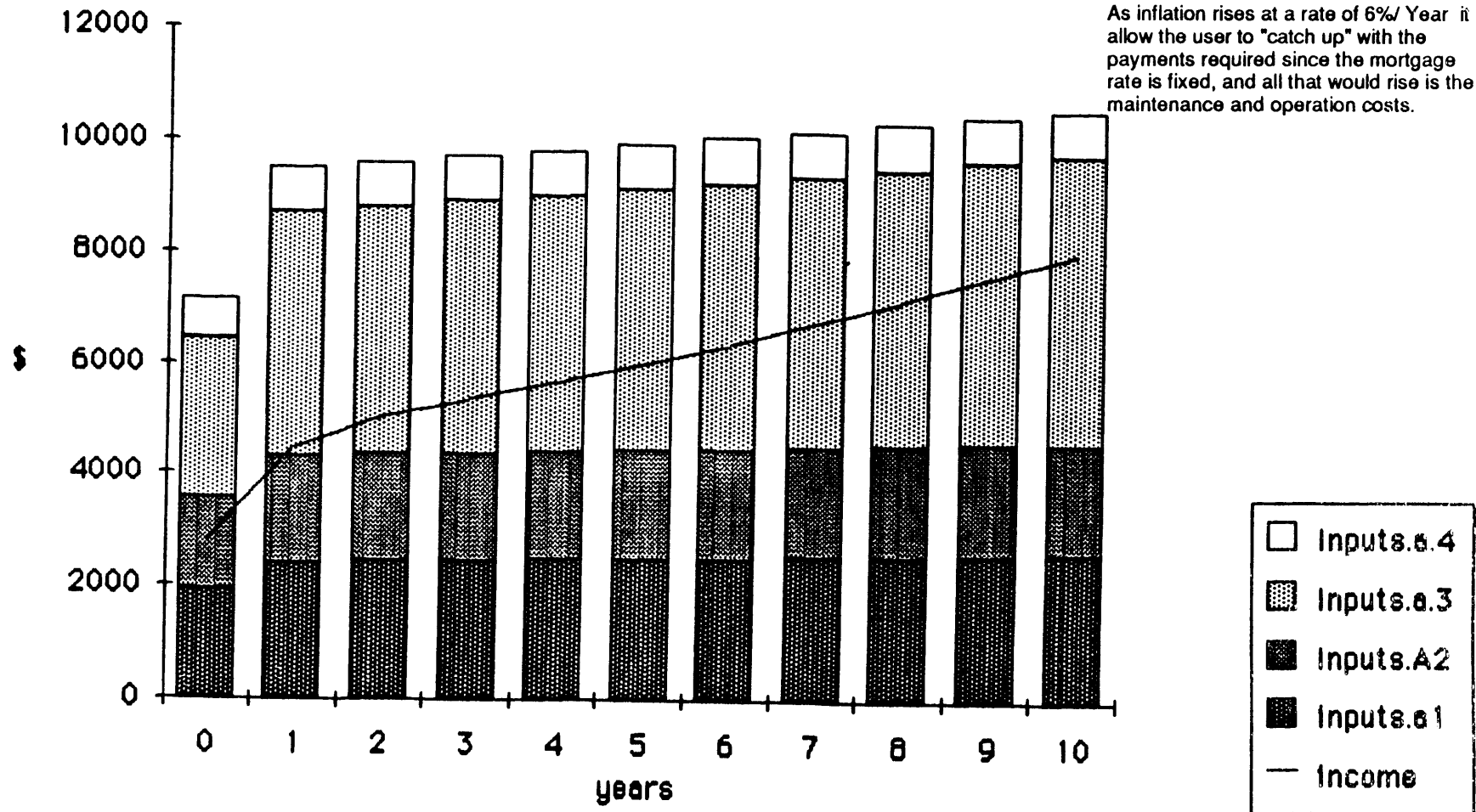

Total input required including the allowable deductions.

This graph is identical to the preceding graph with the exception that the allowable deductions on interest are included. Including this deduction would lower the actual payments from \$9,300/Yr. to \$7,800/Yr, even though our user can only afford \$4,400.

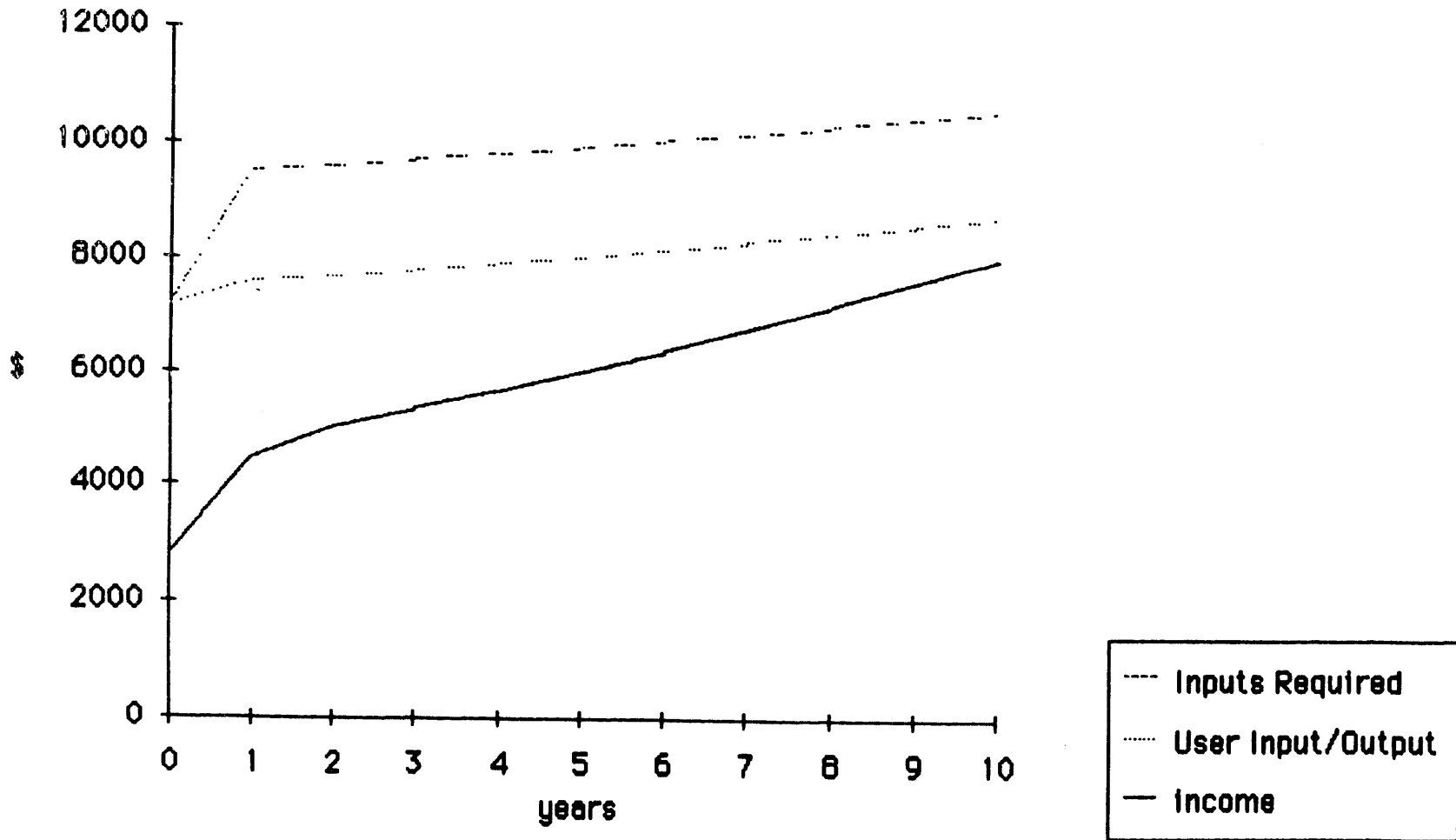

**Input Required for Each Component
Group: A.1-A.4. vs. Income.**

The intent of these graphs is to show the input and output for each component group relative to the user's income available for housing.

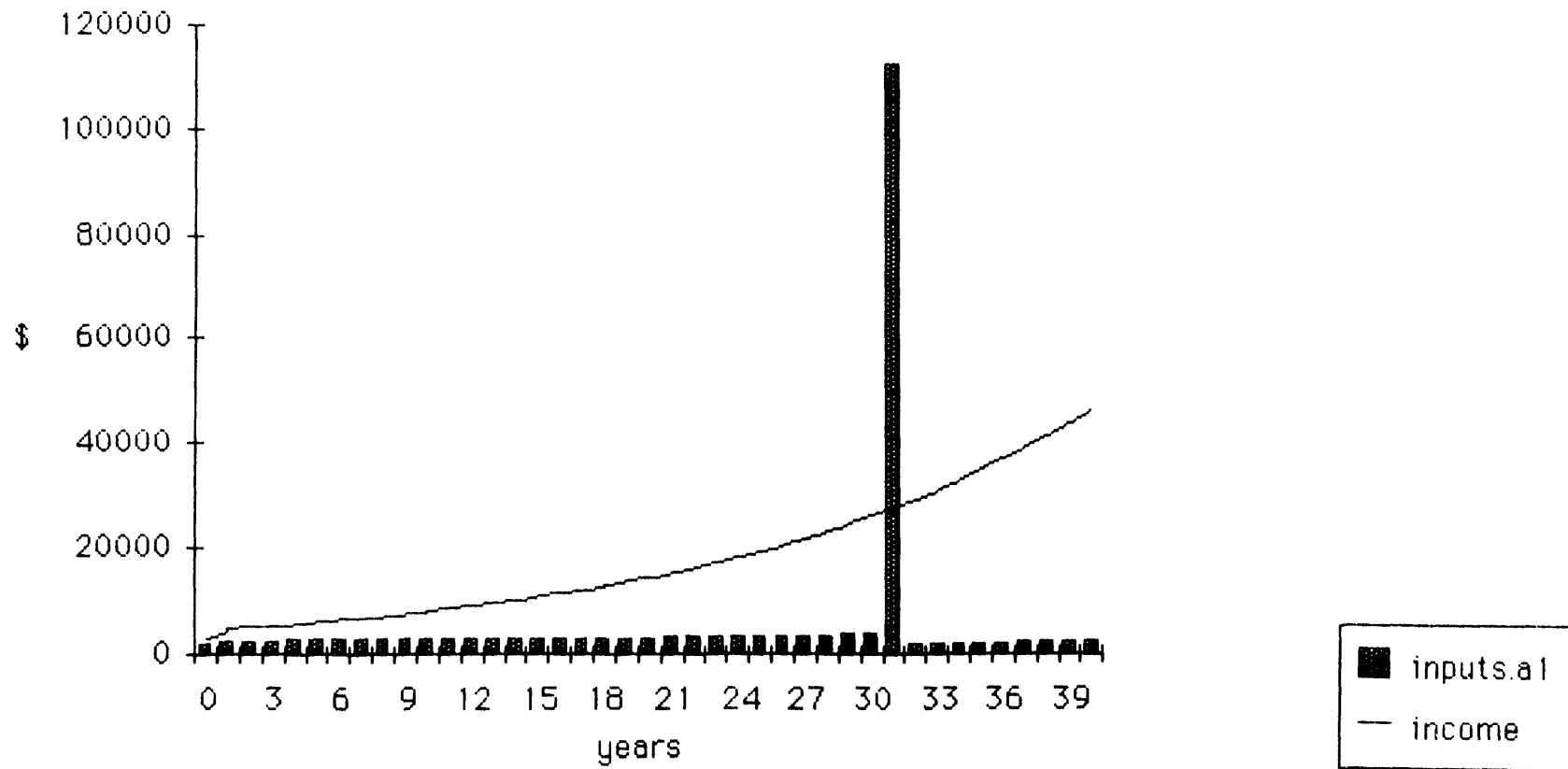

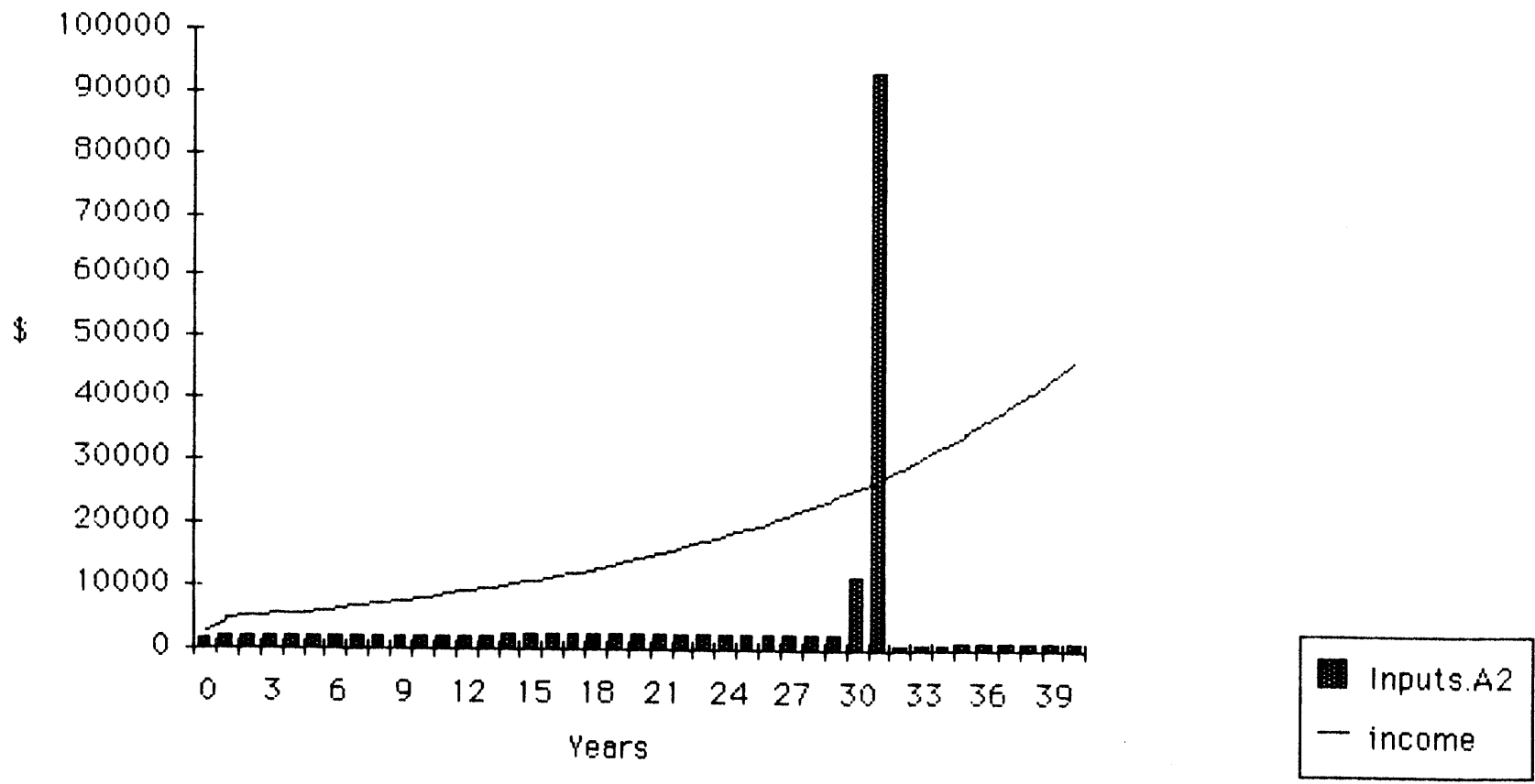

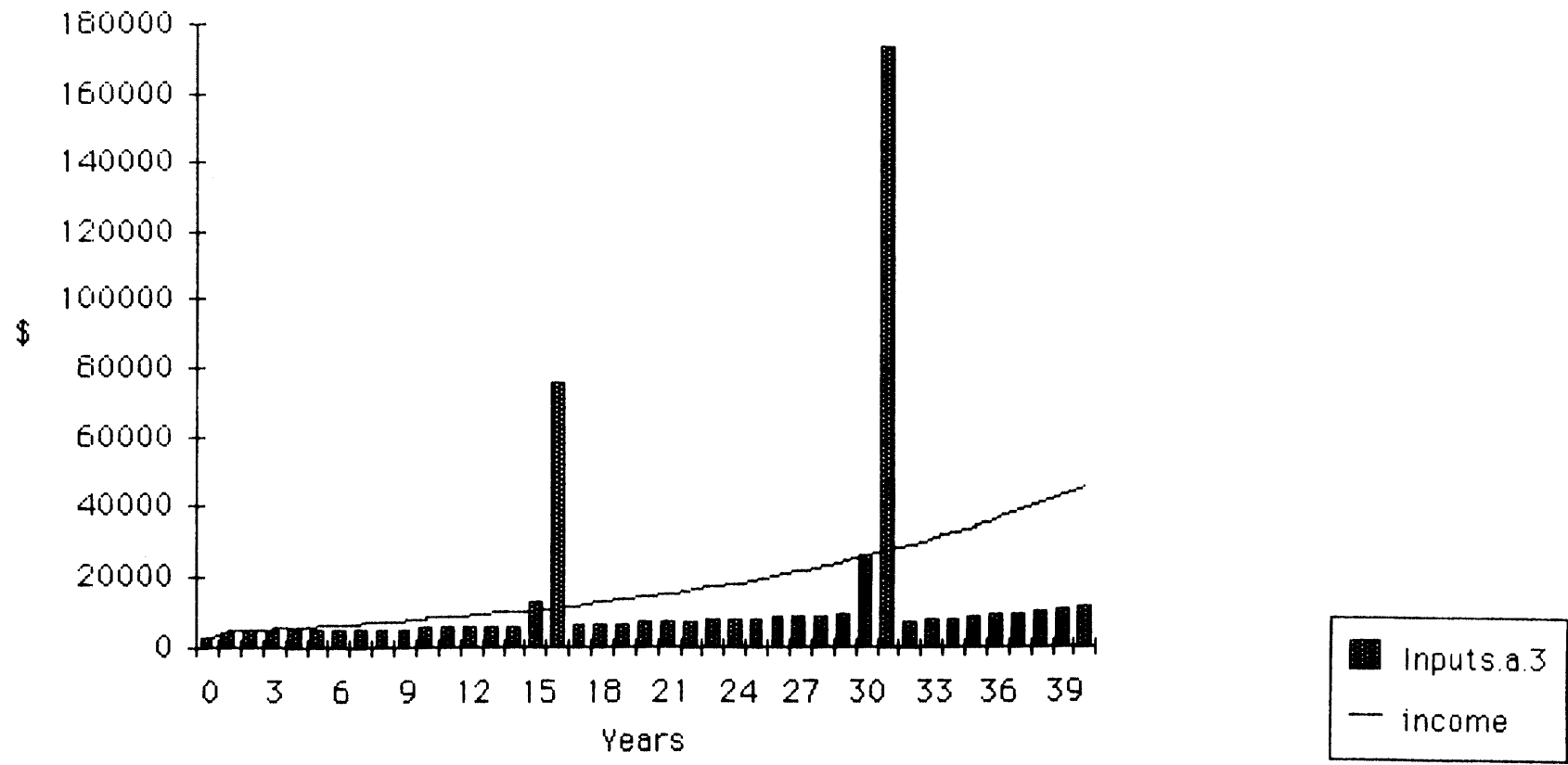

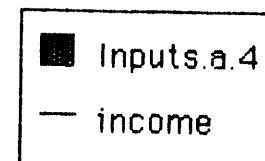
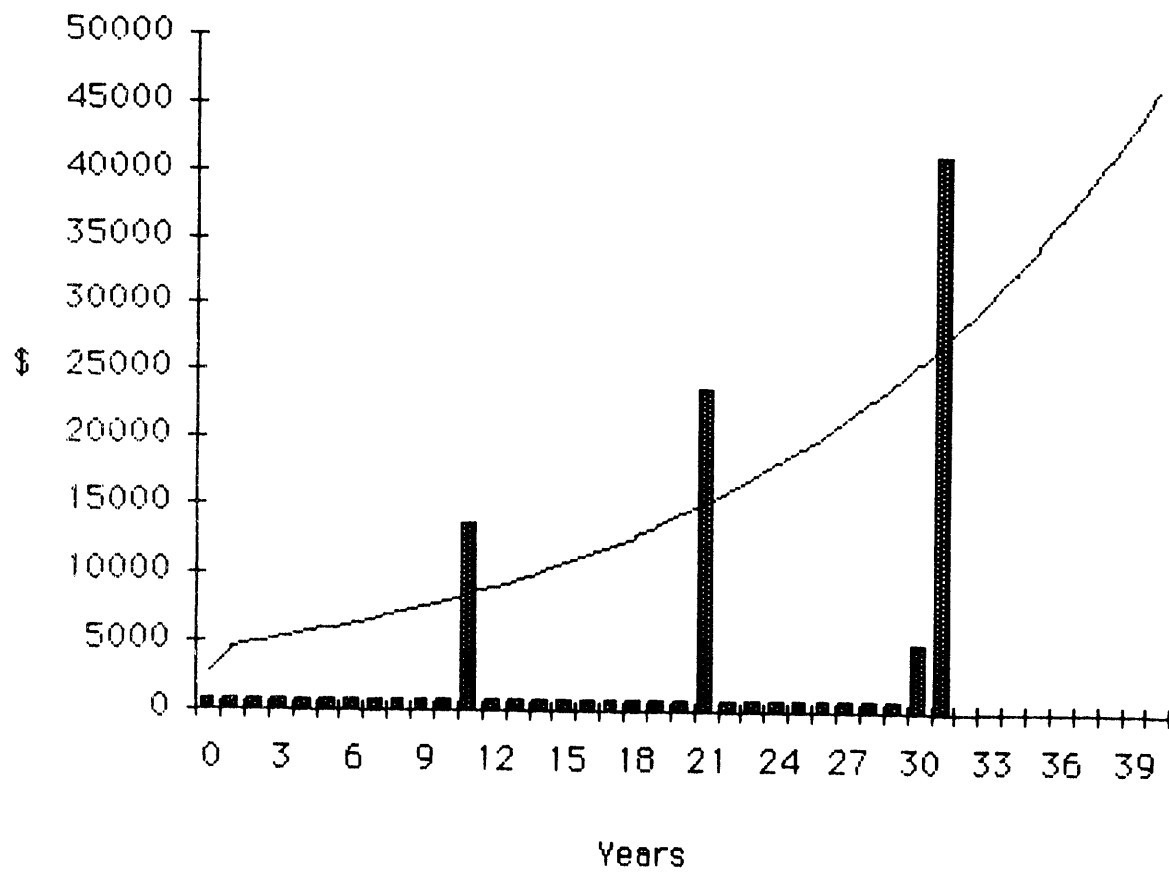

MULTIPLE FINANCING

The Idea:

In his book: A Micro-Economic Analysis of Buildings , the Dutch economist Herman Tempelmans Plat discusses financing and depreciating buildings for terms equal to the lifetime of different component groups. He proposes the possibility of each nearly decomposable system being financed according to a loan term equal to a building components' useable lifetime. Since a structure would last fifty to sixty years we should finance and depreciate it for the same term. This would allow a lower monthly payment for that portion of the building.

Similarly an interior package could be financed for a shorter period equal to its lifetime. By financing and depreciating the building components according to their lifetimes the need to finance and /or pay for replacements will not come as a such a shock to the users, and would provide for a more stable payment pattern relative the demands made by the building. Because parts of the buildings would be replaced and financed seperately, the output required by the building would have a more predictable curve over the lifetime of the component and the building.

Assumptions:

- At the end of a system's useful lifetme it will be replaced in its entirety at the cost of the initial component multiplied by the cost of the inflation factor.
- Each component family will be financed by a standard fixed rate mortgage instrument.
- The interest rate will be equal to 12.5%
- The loan term will be equal to the lifetime of the component group.
- A 10% downpayment would be paid each year before each replacement.
- Each system will be depreciated for a term equal to the lifetime of that component.

The Results and the Analysis

During the first years, the consequences of splitting up the financing according to a building's lifetime would cost the user more than by financing the building as one entity. The first year payment in multiple financing would be \$10,300, while in the case of the standard mortgage it would be \$9,300. This is because what is gained by financing a component over a longer term (60 years vs. 30 years) is more than lost by the higher payment required to pay the shorter term components.

What is noteworthy is that even though the cost of financing in this way is higher initially, and in fact may appear to run counter to our initial goals of making housing more affordable, the user will benefit from a financing system that is less discontinuous over time, and therefore less likely to put larger financial demands on the user at potentially inopportune times. Thus the size of the affordability gap is relatively constant over the lifetime of the project, as opposed to the standard mortgage instrument, where often it appears the affordability gap will be lessened during the initial years, only to be disrupted by a rather severe discontinuity in input required by the building.

In the standard mortgage the user output curve intersects with the building's required input in the twelfth year, while using the multiple financing method these curves did not intersect until the twenty-eighth year.

Another important point is that since the users will have a higher financing charge through out the life of the building, and the size of the debt is increase with each replacement. This entitles the user to a rejuvenated deduction base.

Applications

The model made an assumption that each decomposable lifetime group could be financed over varying terms. It may be difficult to find a bank in this country willing to commit to a loan mortgage for a sixty year term, although 40 year terms are available. On the other hand, finding lenders who will finance shorter term loans may be more realistic. Today mortgage terms on an entire house are available for a fifteen year period. This allows a user to accumulate a larger

amount of equity in a shorter period . Overall this would reduce the total debt paid, but would increase the size of the initial payments. Also, shorter term loans would reduce the size of debt and therefore the size of the interest deduction. A more realistic division of loan terms might be loan periods of 40, 20, 10, and 5 years for the A.1,A.2,A.3, and A.4 systems in respective order.

Given today's extensive use of credit cards and the extensive applications of credit cards to buy larger purchases, it is not unlikely that a user could go to a store which sells A.3 components and packages, and pay for an entire interior package with a credit card.

Multiple financing need not imply that all the lifetime groups of a project should be financed by one institution and one type of loan. Conceivably each component could be financed under different terms and with different lenders. If a user can only qualify for a loan equal 75% of the total house using the typical mortgage, the user may be able to find secondary financing. Secondary financing sources could include other banks, credit agencies, non-profit organizations, family etc. Each one of these sources could determine their own terms of the loan. A user who could not afford a higher portion of the loan could repay the lender in part by guaranteeing a portion of the return on investment.

Essentially there are a large number of combinations available in financing different components owned by different users. First there are the component groups, then the the types of loans, the length of the loan type, and the terms of the loan.

Multiple Financing

B_{ij} = Multiple Building Systems
 F_{ij} = Multiple Financing Sources
 L_{ij} = Multiple Loan Types
 U_i = Users

$$\begin{bmatrix} B_i \\ \vdots \\ B_j \end{bmatrix} \times \begin{bmatrix} F_i \\ \vdots \\ F_j \end{bmatrix} \times \begin{bmatrix} L.T.i \\ \vdots \\ L.T.j \end{bmatrix} \times \begin{bmatrix} U_1 \end{bmatrix}$$

Total Input Required vs. Income

This graph show the total input required of the building over a 40 year period using multiple financing.

Although the building is less affordable in the initial years (\$10,300/yr vs. \$9,300/yr) the input curve does not deviate as severely from the income curve in the later years as it does when financed by single mortgages. year is equal to \$10,300 vs. \$9,300 for the standard mortgage.

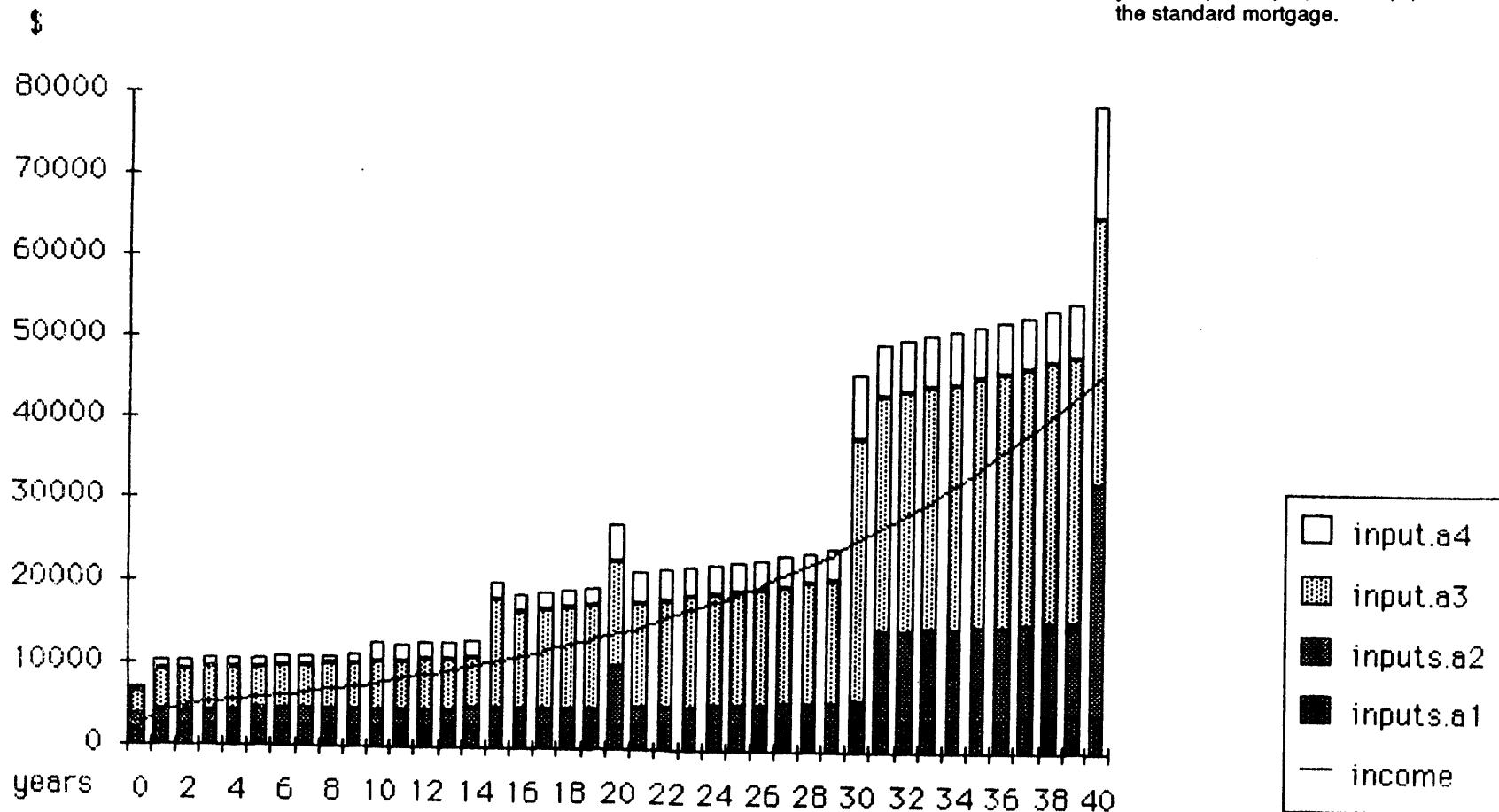

Total Input vs. Available Income, the First Ten Years.

The total input required of a building in the first ten years show a disparity between the income available and the input required. The initial cost in the first

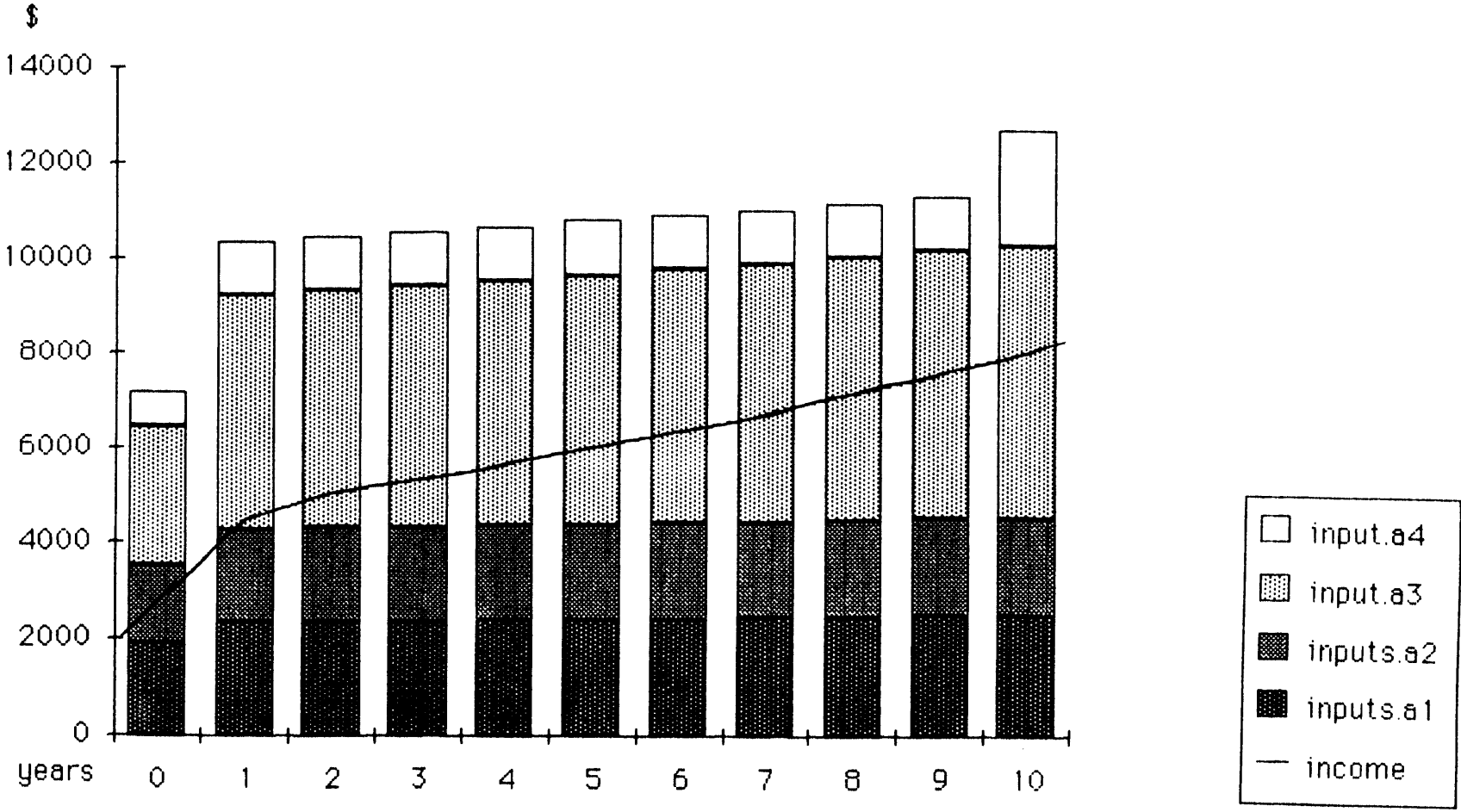

**Input required for the A.3 & A.4
Component groups vs. Income
Available.**

This graph shows the input required for owning the A.3 & A.4 component groups. We notice that available income is adequate enough to afford these components, but then the question arises as to who will own the remainder of the building and make up for the remainder of the input required. See the section on "Multiple Ownership."

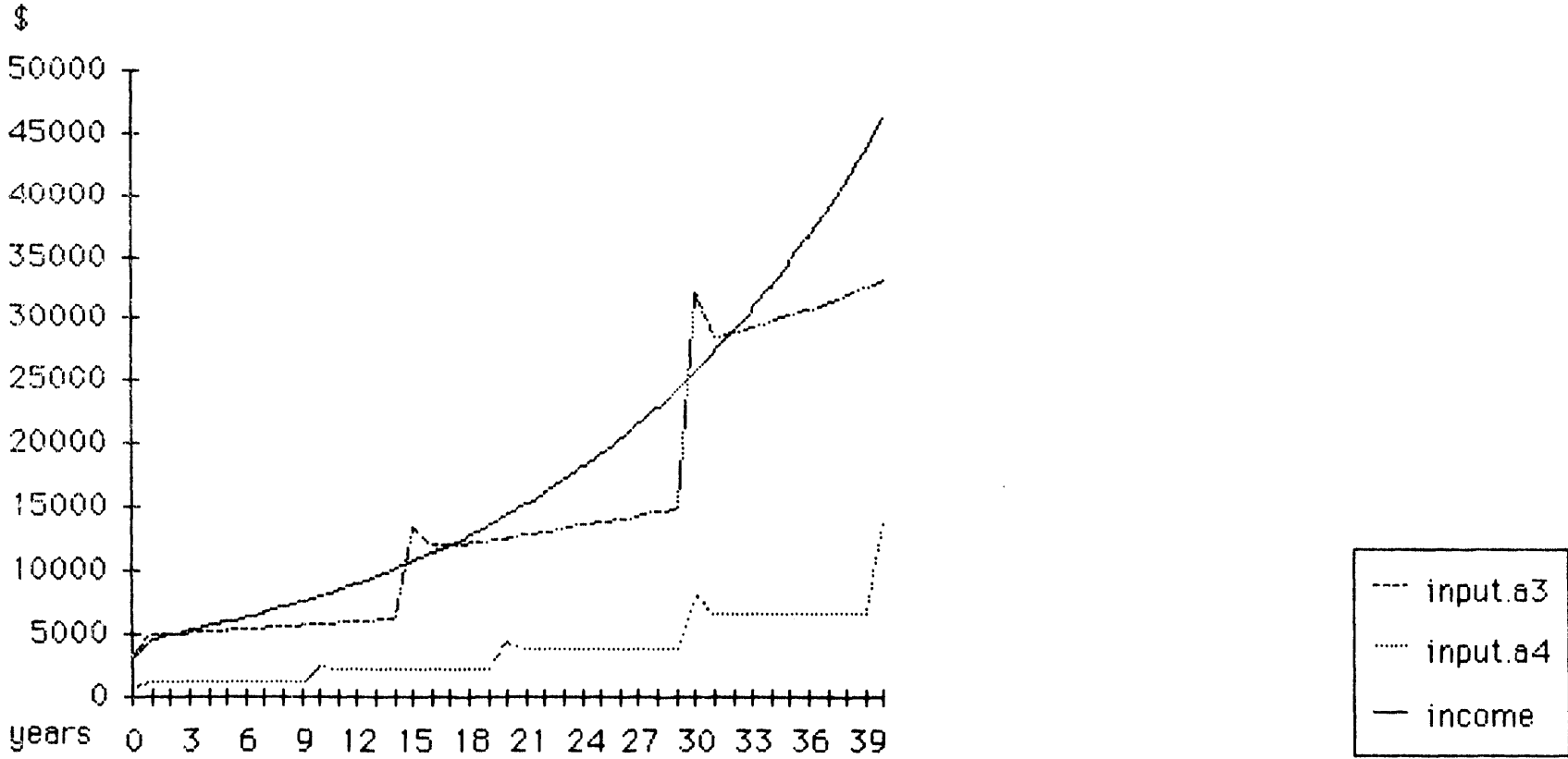

Input Required vs. Income w/ Proceeds from Sale.

If the the appreciated value of a house could be used on a yearly basis to help users meet their required yearly payments, the affordability curve would appear as such. With an appreciation rate of 6%/Yr. (equal to the assumed inflation rate) the building would be affordable throughout the forty years.

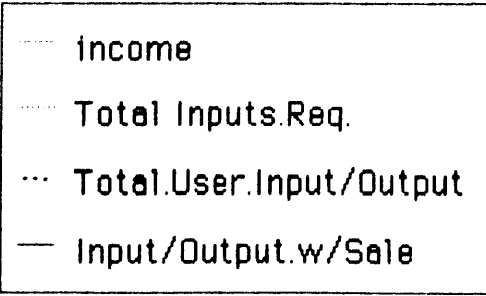
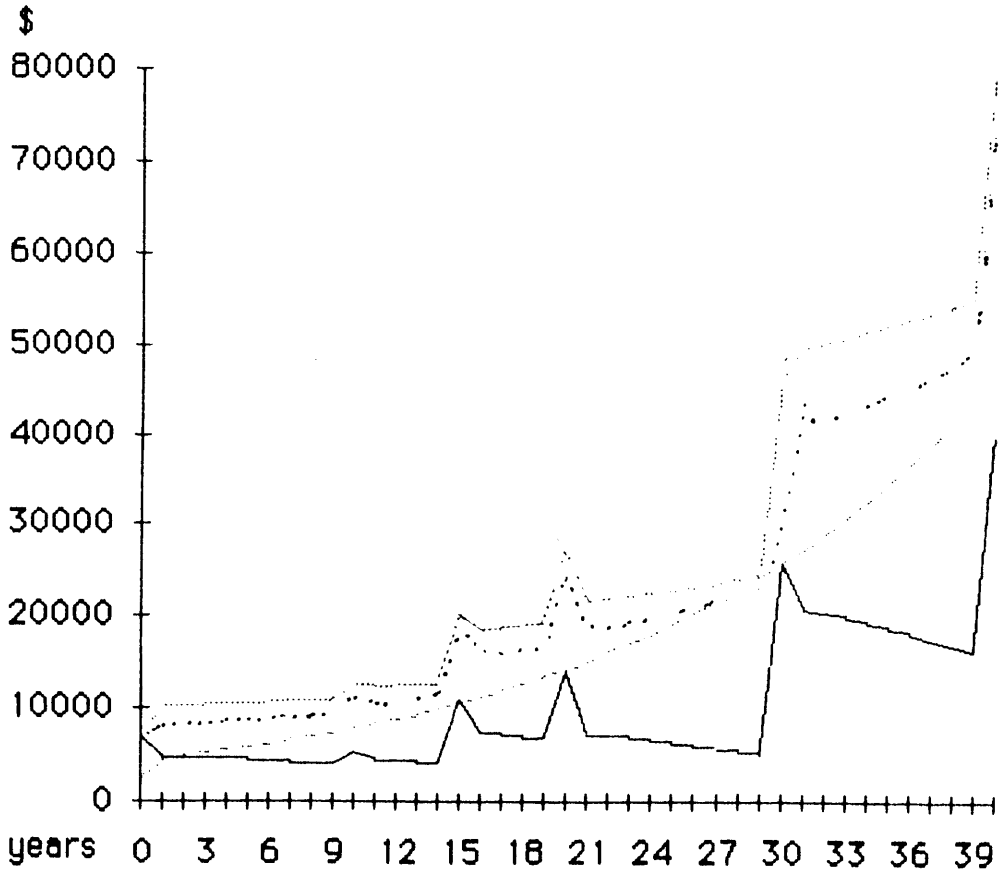

MULTIPLE OWNERSHIP

The Idea

The notion behind multiple ownership originates from the concept of shared equity. Shared equity recognizes that housing cannot be affordable in its entirety to users and therefore, allows a second non-occupant to co-own the same house.

The idea works something like this: an investor and a user-occupant buy one unit of housing together. Both parties make monthly payments to the bank, but the user also makes a monthly payment to the investor. Thus, the total output for the user-occupant comprises initial downpayment (this is optional), monthly mortgage payments, and rent to the investor. The investor's output comprises initial downpayment, and monthly mortgage payments. The investor's input is rent received by user, depreciation deductions, amortization and appreciated value on sale. The total output received by the occupant is deduction on interest, amortization and appreciated value.

One advantage an investor has in a shared equity project is that an investor in a rental unit wouldn't have, is that the investor is assured that the user-occupant will maintain the property, since the user is also an equity holder. The user-occupant has an advantage over tenants in the rental market because the user-occupant can gain equity from payments which otherwise would be going directly to a landlord. Furthermore, the user-occupant's ability to deduct interest on the mortgage would reduce his overall housing costs.

By thinking of buildings as being composed of nearly decomposable systems the above example can be expanded to include more than two users. Multiple ownership mechanisms are available to different users depending on their income levels. Furthermore, the amount of equity a user has in a project can change over time so as to meet the resources available to that user. Thus as the income level of an equity poor user rises over the years, this user can choose to buy or to increase the equity share in the entire project. Further elaborations on this idea will be discussed in later sections.

Assumptions

- Each decomposable system is financed separately, and for the term of that component's lifetime
- Each decomposable system is replaced after its usable life is depleted.
- The user-occupant owns the A.3 and A.4 systems, while the investors own the A.1 and A.2 systems.
- The user-occupant pays rent to the investor for the benefit of using the A.1 and A.2 units.
- The user-occupant pays all the input required by the A.1 and A.2 systems and therefore is entitled to all the output produced by those systems (deductions, sale, equity).
- The investors pay all the input required by the A.1 and A.2 systems and receive all the output of the same systems.
- The amount of rent paid is equal to a fixed rate of \$5,220 in the initial year multiplied by the composite affect of the inflation rate each year.

Results/Analysis

One may graphically translate an affordability test by analyzing the input/output curves; the input/output curve of the building, and the input/output curve of the user. If these two are not closely linked there is an affordability gap. By using the above mentioned assumptions in which the user-occupant owns the A.3 and A.4 systems, we can observe from (see graphs) that these two curves are beginning to shadow each other. This is largely due to two facts: 1) the user owns only a portion of the building, and 2) the user-occupant can now partake in the benefits of tax deduction and appreciated value not available to tenants. Even though the user-occupant has to pay rent to the investor, the amount of rent that the investor charges is less because of the added benefits an investor derives from a building: such as, depreciation deduction; including interest deduction and appreciated value.

In the first year, the user-occupant payment for housing will be equal to \$7,500. as opposed to the \$10,300 required each year by the example demonstrated in the base line model

strategy. Even though there is still an affordability gap during the initial years, the size of the gap between the curves is reduced, and the year in which the input-output curves of the user and the building intersect is reduced from twenty eight years in the case of the multiple financing scheme to nine years in the case of multiple ownership.

Besides requiring a lower monthly payment, the user also requires a lower initial downpayment which may be especially useful to the equity-short user. In return the user-occupant must accept a limited ability to generate as much appreciation in value, given that it must be shared with a co-owner.

-The consequences to the investor:

According to the example I had modeled, the investor is required to make monthly payments equal to the input required of the A.1 and A.2 systems. The investor is fortunate in that the maintenance costs for the A.1 and A.2 systems are lower than the life-cycle costs required of the faster depreciating A.3 and A.4 systems. This is especially well suited for investors who do not like to worry about rapid fluctuations and demands made by their investments.

The input received by the investor come in three primary forms: rent, depreciation deduction, interest deduction, and appreciated value. Every year that a system or its components need to be replaced, an investor will have a higher depreciable base from which to further depreciate income, since the replacement of that system will be substantial and would be recognized as a depreciable investment.

The total allowable deductions decrease over the years, as the size of the debt on the loan itself decreases. As previously stated, the rental income remains constant with inflation. The value we derive from appreciation is dispersed in yearly increments. Thus every year the value of the A.1 and A.2 systems appreciate 6%. This value in turn is registered as an input to the investor.

Together, the input and output curves make for a curiously behaving curve. The particularity of this curve does not originate from the predictable payment required by the building but from the curious pattern of the output provided.

Applications

•Public sector

Public housing has long been plagued with the tenant's recognition that it was a last alternative. Public dependency is encouraged by government's willingness to pick up the tab on maintenance, repair, and other life-cycle costs, with little user accountability. Thus public agencies are faced with a double edged problem; rising life-cycle costs, and reduced funding.

In theory every person in this country is entitled to a minimum income, whether through minimum wage, welfare, unemployment benefits, social security, etc. These sources of income could be applied to housing payments which conceivably could also be a way for a user to amass equity. Thus a public housing agency could lease the A.1 and A.2 component groups to the user. The user would utilize a portion of their minimal monthly income and pay for whatever portion of the A.3 and A.4 components they could afford. The user-occupant would then be the owner of a certain portion of the building. The user would be able to now gain equity through monthly payments, amortization, and appreciated value. Furthermore, since the user would be held responsible for the maintenance and upkeep of the portion of the building owned by the user, the public housing agency would have a reduced role in financing maintenance and replacement costs. This could be a high source of substantial savings to public housing agencies, since maintenance and replacement cost for the A.3 and A.4 systems are proportionately higher than the A.1 and A.2 systems. Furthermore, the public housing agency could be take advantage of the fact that these costs are labor intensive and require relatively little skill and could thus therefore be relatively easily by the user on his own initiative.

As the user-occupant's income would rise, the user-occupant could opt to increase his equity share in the building either by building more A.3 and A.4 systems, or by purchasing shares in the A.1 and A.2 systems from the public agency. In theory, if the income level of a user-occupant increased sufficiently or the public agency was willing to sell shares of the A.1 and A.2 systems at subsidized rates, the user-occupant could own an entire building in time.

•Private Sector

A larger institutional investor with substantial investments in real estate might benefit from the same principles used above in different contexts. The institutional investor could build or buy A.1 and A.2 systems, which thereafter could be developed in one of several fashions. The institution could sell the A.3 and A.4 systems to the user-occupant directly with an option for the user-occupant to buy the A.1 and A.2 systems from the institution over time. The institution in the meantime would receive rent in return for benefit of using the A.1 and A.2 systems. In the case of an investment trust, the rights to interest and depreciation deductions could be transferred to user-occupants. An increase in the value of the property as a whole would be transferred to each system commensurate with the value of that system.

Several interesting scenarios could be derived from such an arrangement. For instance the above arrangement might prove useful to a young professional living in New York who does not have enough capital to buy a house/unit but would like to accumulate equity, and who is also uncertain about the prospects of staying in New York for more than two years. In this case, the user-occupant could buy an A.3 and A.4 system from an institution, real estate developer, or syndicate, and rent the A.1. and A.2 system. After one year if this young professional is transferred to Oklahoma City, the value of the accumulated equity and appreciated value in the A.3 and A.4 systems could be transferred to another project owned by the same firm owns in Oklahoma City. If the same firm did not own a project in the user-occupant's desired location, the user-occupant could transfer the value of that equity to another firm. It may be that the user was particularly fond of some of the appointments in the A.3 and A.4 systems which were specially

designed. The user-occupant, upon moving, could simply dismantle those special components and take them to his new unit in Oklahoma City (with of course a reduction in accumulated and transferable equity.)

After several years the user-occupant may be thinking of settling down in Oklahoma City and could buy the A.1 and A.2 systems from the original institutions. This user occupant could purchase the systems in two ways: Either he could buy his shares of the A.1 and A.2 system outright or he could buy A.1 and A.2 shares equal to the value of the A.1 and A.2 system in Oklahoma City.

The second option offers further interesting permutations and opportunities. Because the A.1 and A.2 shares would be collectively owned by users over a larger pool of similar investments, any radical fluctuation in a local market condition would be dissipated by the size of the investment pool. If someone had bought a house in Youngstown, Ohio before the steel crisis for instance, the consequences of a deflationary market and deflated local prices could be damaging to the user-occupant who had invested an entire life's savings in a single house. In the Youngstown example since the user-occupant would own only the A.3 and A.4 systems outright and would be a shareholders of A.1 and A.2 systems, the total loss would be equal to the loss in the A3 and A4 component groups and a share of the loss loss of the A1 and A2 component group owned by the pool of investors.

As one can imagine there are numerous conceivable variations on this form of ownership, given the combinative possibilities available by decomposing a building.

- **Community/City Groups**

In a private/public partnership a community may want to develop a part of the city. The city either through its own source of funds, or outside funds gets enough capital to develop the A.1 and/or A.2 systems, and thereafter homesteaders are invited to fill in the projects according to certain predetermined constraints set forth by the city. The city could either sell the A.1 and/or A.2 at reduced rates, or rent them at a nominal rate, allowing the homesteaders the options of

buying them in full in latter years. Or the city could simply grant the support to users as a form of subsidy or investment on the part of the city. The city could benefit in return from an increased tax base created when areas would be revitalized or new areas were developed by this method.

• **Small Ad hoc Community Developers:**

A local community group intends to develop a small 12 unit project which is to be owned by 12 user-occupants. The ownership agreement between the different user occupants goes as follows: The community group, which establishes itself as a limited partnership, owns the A.2 and A.1 systems. All of the user-occupants are limited partners in this partnership. The user occupants own the A.3 & A.4 systems outright and pay rent to the community group for the benefit of using the support. Because the community group is a limited partnership it can benefit from depreciation deductions that regular homeowners cannot. Therefore, even though the building receives the same amount of total input to the building, the total output to be provided by the user is increased by the added benefit of deduction. There are limits to the amount of investment a user can deduct in such cases, where the user will in essence be paying himself rent. The ever changing tax laws that regulate rent, presently state that the rent rate must be a fair and equitable market rate. This prevents a user from paying no rent recording paper losses, and therefore sheltering more. Another benefit of this method is that losses and gains to such items can be dissipated over a larger pool of users.

Multiple Ownership

- B_{ij} = Multiple Components
- U_{ij} = Multiple User with Multiple Needs
- A_{ij} = Multiple User Agreements Binding the Users
- F_{ij} = Multiple Loan Types

$$\begin{bmatrix} B_i \\ \vdots \\ B_j \end{bmatrix} \times \begin{bmatrix} U_i \\ \vdots \\ U_i \end{bmatrix} \times \begin{bmatrix} UA_i \\ \vdots \\ UA_j \end{bmatrix} \times \begin{bmatrix} F_i \\ \vdots \\ F_j \end{bmatrix}$$

Total Input Required vs. the Total Available Income.

Total input required for the multiple ownership is identical to the input required for the multiple financing. As we will see however the output produced by the building will vary according to which users are interacting with which components.

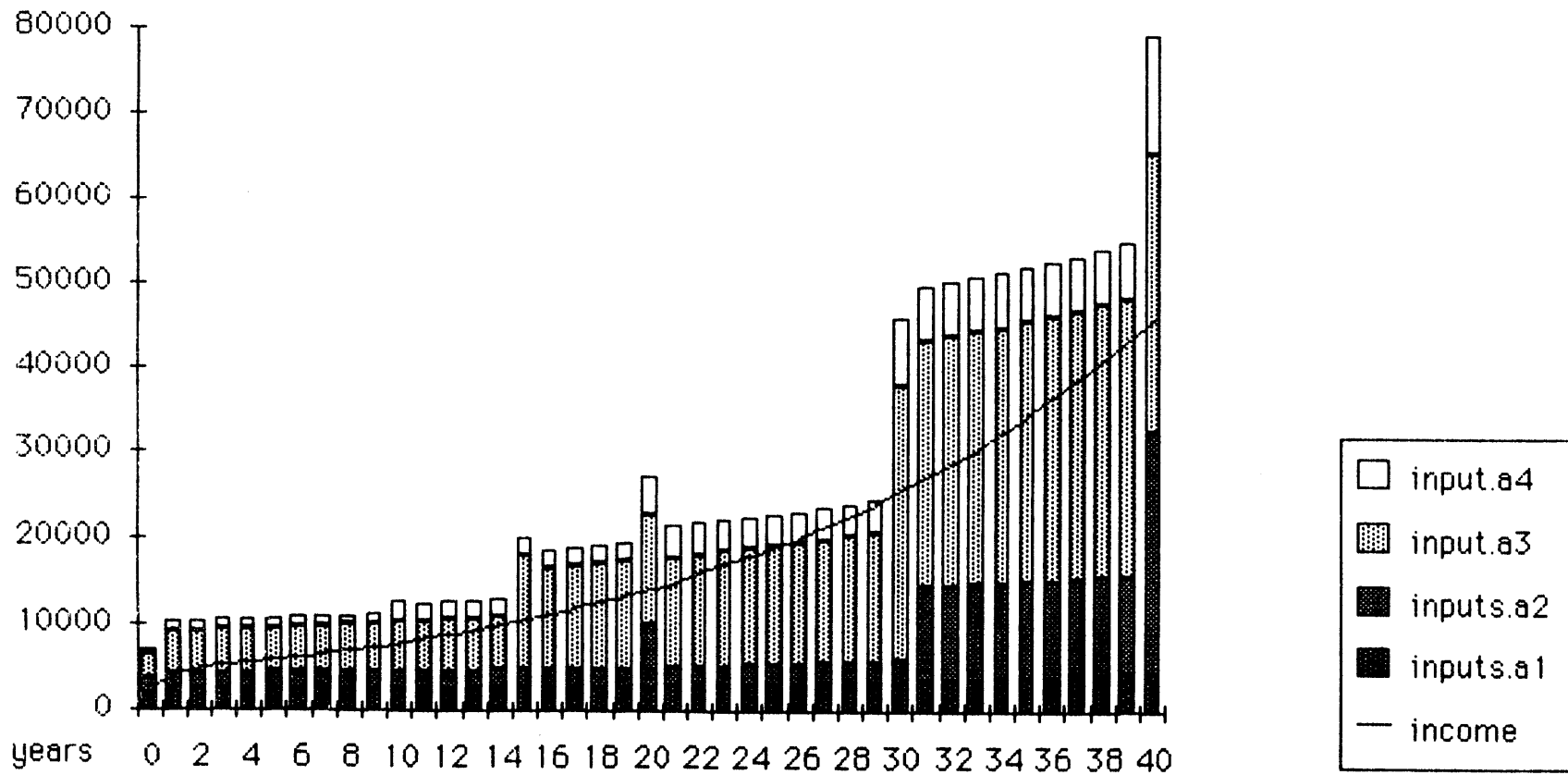

Input Required by A.3 & A.4 vs. Income Available.

In this strategy it is assumed that the user-occupant owns the A.3 & A.4 component groups while renting the A.1 & A.2 from a non-occupant user. This graph indicates what the input required would be of the user occupant to own the A.3 & A.4 component groups. (Tax deductions and rent paid to the user non-occupant is not included)

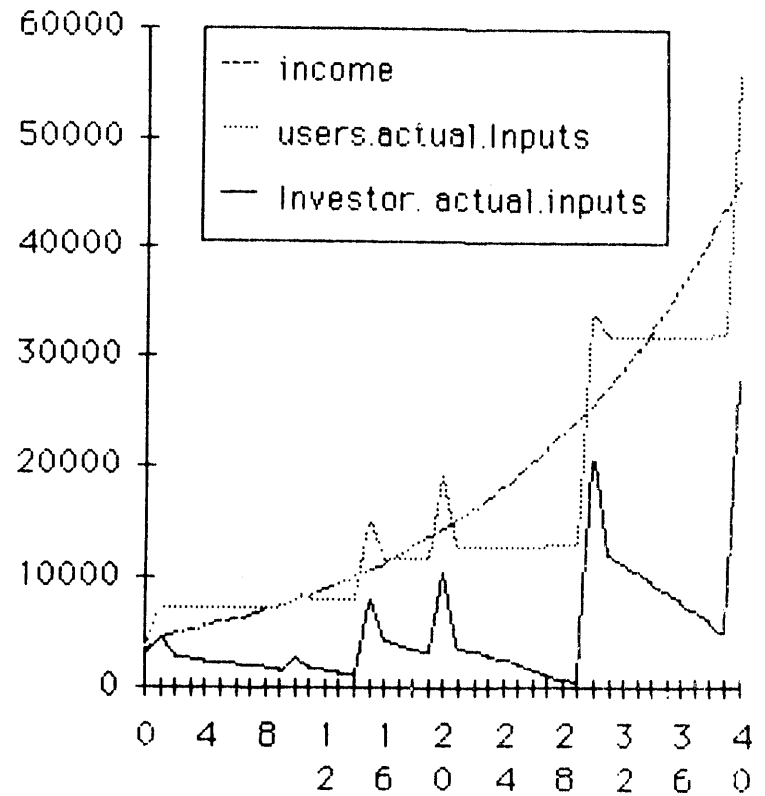
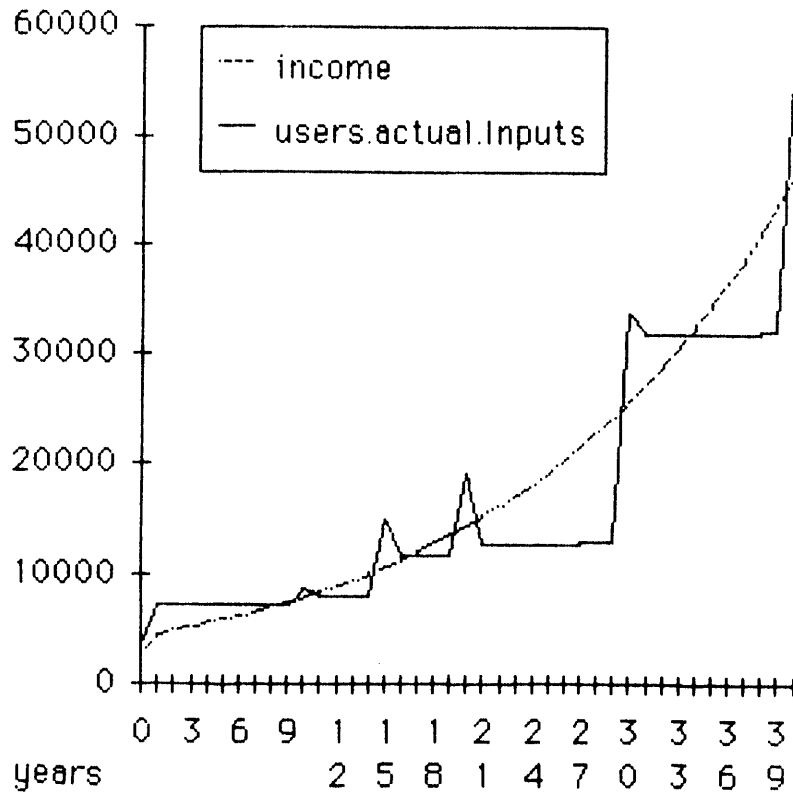

Input Required of Non-Occupant User.

The non-occupant user must meet the input required of the A.1 & A.2 systems. Thus the lines of the investor input required and the user output required are identical. The investor however does have the rights to the output produced by these systems. (see following graph)

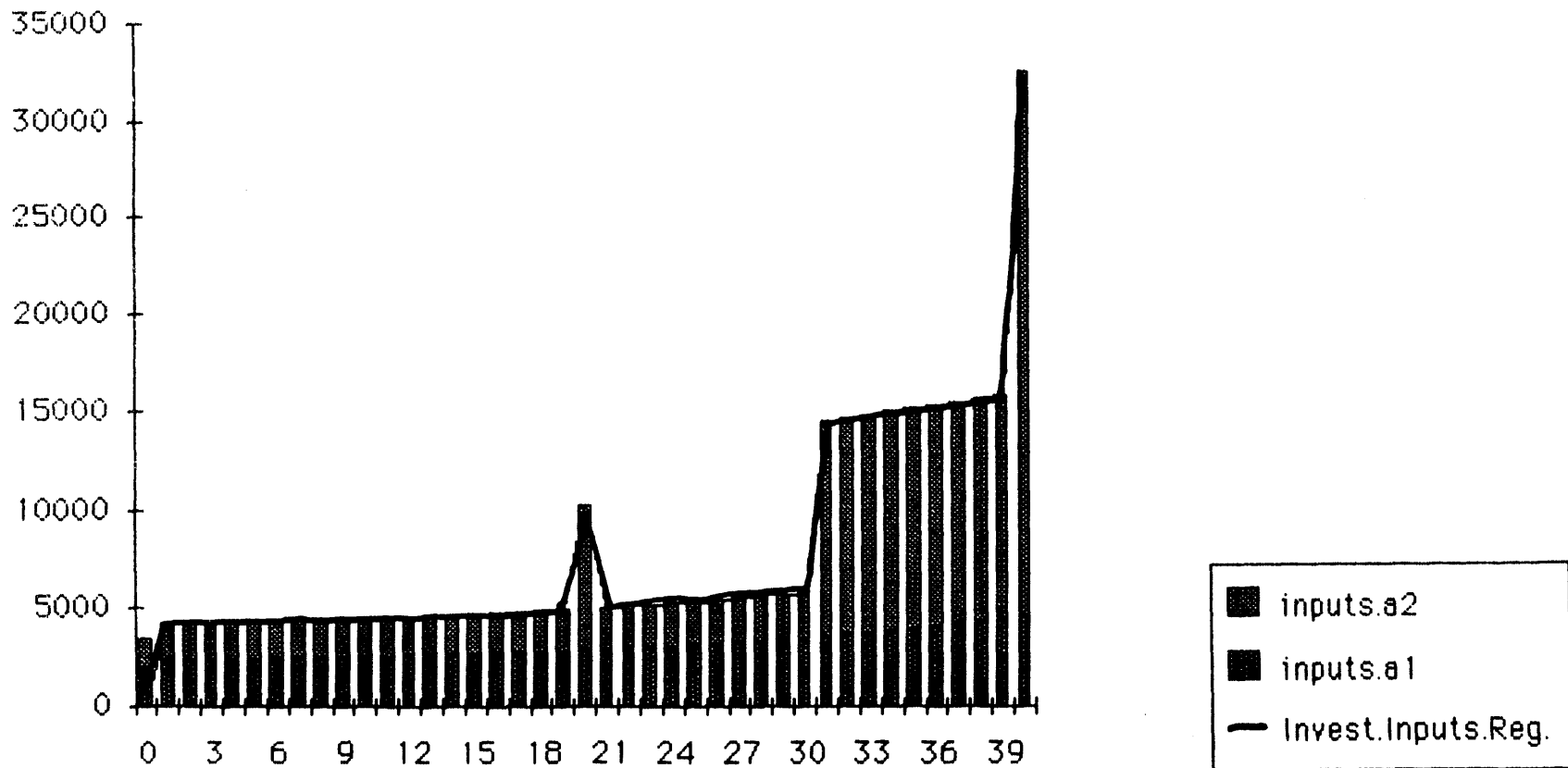

Input Required by A.1 & A.2 vs. Non-Occupant Combined Input/Output

Although this non-occupant user must meet the input required of the building, this user may benefit from the output produced by the building component which in this case include rent, deduction on interest, and deduction on depreciation. (the output: return on sale is included in the following diagram)

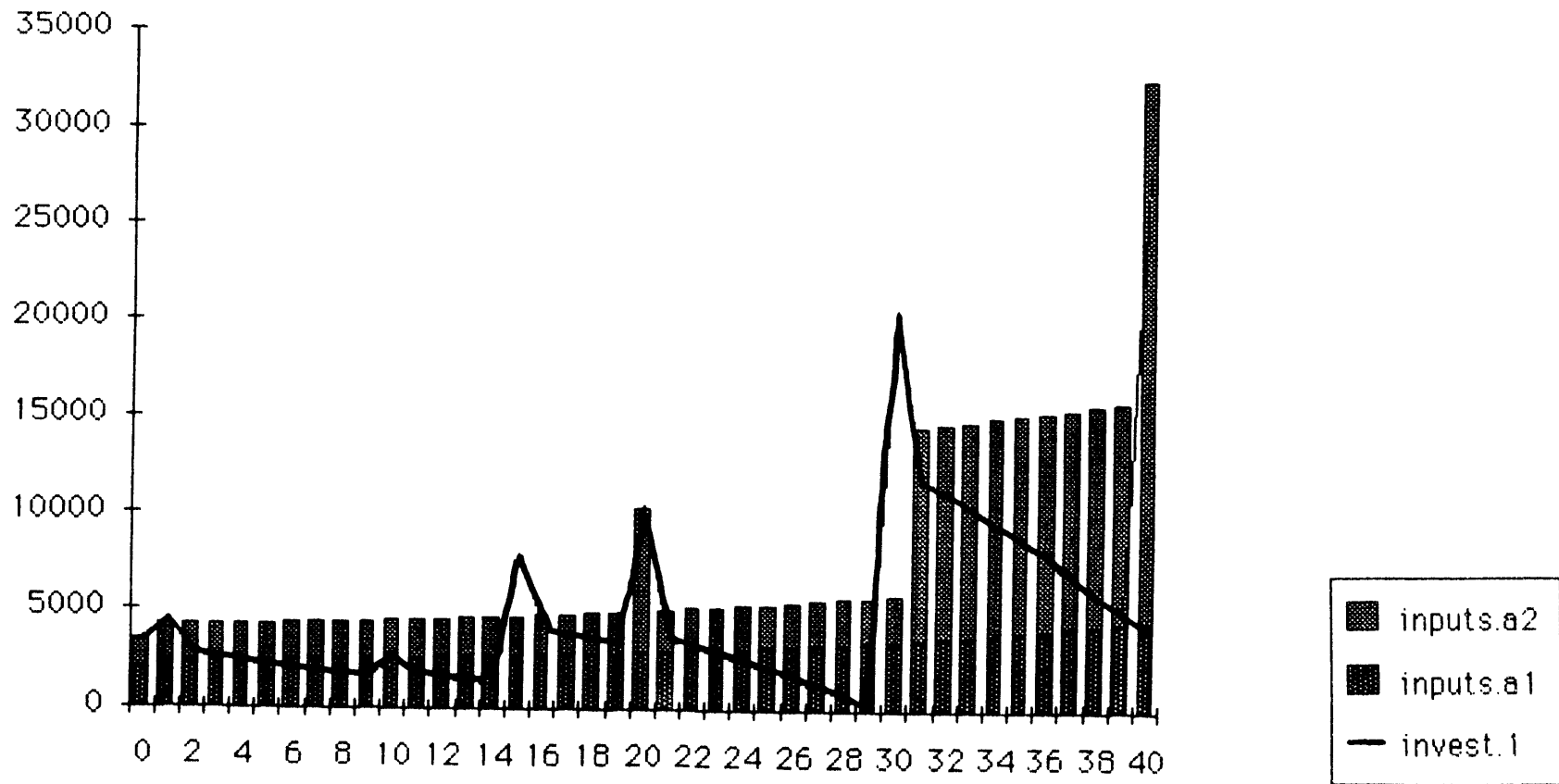

**Total Input Required vs. Total Output
(including sale) Provided by A.1&A.2**

This graph includes the yearly increase in value of the A.1 & A.2 systems as an output. If the discounted value of the appreciation on sale could be included in the year of appreciation the investor would be guaranteed a positive cash flow. What the real return on investment is has not been calculated.

Appreciation was assumed to equal the inflation rate of 6%.

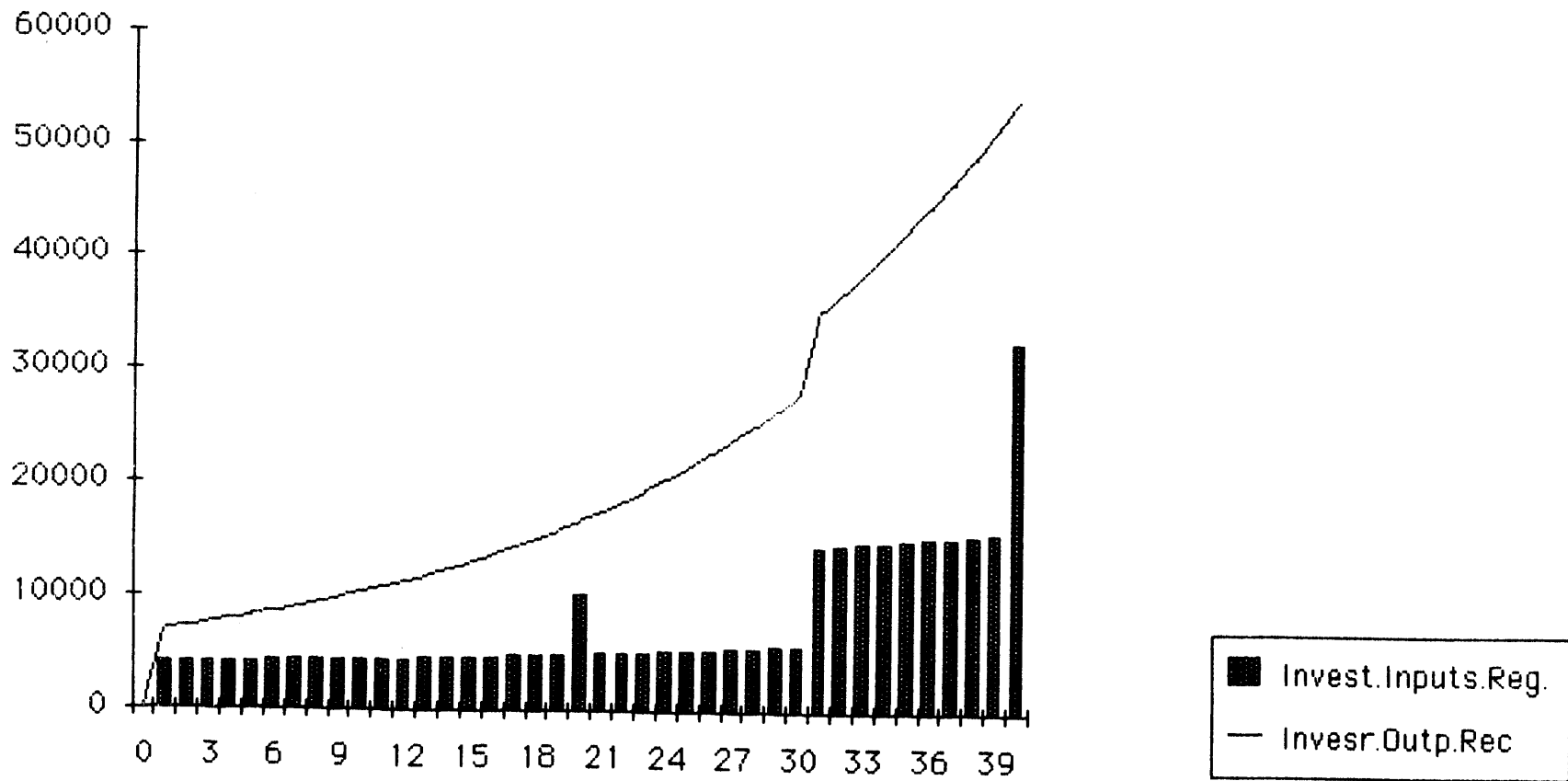

PHASED CONSTRUCTION

The Idea:

Given that it is unlikely that one user can afford an entire building initially, this strategy looks at the notion of building only what one can afford initially and then building incrementally over time as the user-occupants' resource base increase. The first thing that would have to be built would be the A.1 & A.2 systems. By necessity, a foundation structure and the envelope are required to protect the user and the building from the elements of nature. Thereafter, whatever portion of the building could be built with the resources available would be. Since the installation and construction of the A.3 units tend to be more labor intensive and in general require less skill than the installation of the A.1 & A.2 systems, to assume that users can install an entire A.3 package with minimal assistance of skilled labor is a realistic. To this is the installation of the electrical and mechanical systems would be the exception.

The modeling of this strategy was completed by determining what portion of the space a user could afford initially and over time if the user built the A.3 by himself. The intent was to discover in which year of the building's life a user could afford to own a complete house.

Assumptions

- The user buys a A.1 & A.2 in its entirety in the first year.
- This A.1 & A.2 is used by financing it with split financing.
- The user buys that portion of the materials that the user can afford initially and takes out a loan for that amount.
- The user builds that portion of the A3 unit for which he has material available.
- As the user's income level rises relative to inflation, more material is bought and built incrementally until there is enough material available for the project's entire completion.

Results

Simply stated, the results of this section indicate that by year five of the study, a user could afford 100% of the total project if the labor was completed by the user. The labor portion of the cost of the A.3 section is equal to 50% of total cost. Because of this fact the user can buy 50% more material in the initial year than if he had the entire system built with skilled labor. Thus in the first year the user can afford 100 % of the the A.1 & A.2 and 73% of the A.3 & A.4. If the user's own labor were not be used in the first year the user could only build 37 % of the A.3 & A.4. The next question then is what does 73% of an A.3 & A.4 buy and would it be sufficient to inhabitat? This question is partially dependant on the relative size of the unit. That is, 73% of an studio apartment doesn't leave much superfluous space. However in the case of the unit being studied (two bedroom unit of 1350 SF.) there exists more slack within which to work. The consequences of not having a finished bedroom and no trim on the floors would be less problematical in a two bedroom unit than it would be in a studio. The code requires that certain definite conditions be met in order for it to be inhabitable. These would include the bathrooms, the kitchen, the utilities, and the mechanical systems. Thereafter certain living spaces would be necessary, such as bedrooms, etc. Much of what would determine what is minimally acceptable depends on the improvisational ability of the user, and their tolerance to a less than complete building.

Applications

The notion of "sweat equity" is not a new one. However, by thinking of a building as consisting of two levels, the A.1 & A.2 and the A.3 & A.4, each of which requires different skill levels to construct, it becomes possible to be a bit more systematic about what the user can or cannot build, over time. The principle is simple: first put a roof over one's head and then build the interior. Conceivably this could have several types of applications in different markets.

In the private sector developers could build unfinished A.1 & A.2s and shells, which would only provide the exterior definition and the required utility accesses. Then the users in the

market could come and build the interior at their own pace, so long as it meets the minimum requirements in the code. This may be a problem since in order for a building to get an occupancy permit it must have a minimum of finish, typically no less than the completed installation of all the electric and mechanical systems, as well as the erection of all wall surfaces.

Community groups and public agencies may find this useful since it would require less expenditure on the part of the community developer. In this case a community group could leverage a much larger project by simply building the A.1 & A.2 and allowing users to complete the projects according to the users' available resources.

Phased Construction

- B_{ij} = Multiple Building Systems
- T_{ij} = Multiple Phases of Construction/Implementation/Labor
- U_{ij} = Multiple User
- F_{ij} = Multiple Financial Mechanisms
- L.M._{ij} = Labor Material ratio

$$\begin{bmatrix} B_i \\ \vdots \\ B_j \end{bmatrix} \times \begin{bmatrix} T_i \\ \vdots \\ T_j \end{bmatrix} \times \begin{bmatrix} L.M.t_0 \\ \vdots \\ L.M.t_n \end{bmatrix} \times \begin{bmatrix} U_i \\ \vdots \\ U_j \end{bmatrix} \times \begin{bmatrix} F_i \\ \vdots \\ F_j \end{bmatrix}$$

Phased Construction: The year of completion.

If the user would only build with the resources available to that user including personal labor, in which year would the user have enough resources available to complete the building. That date would occur just before the fifth year. This is assuming that the user would construct their own A.3 and A.4 units, while the A.1 & A.2 would be constructed by conventional means

After the fifth year the curve becomes meaningless.

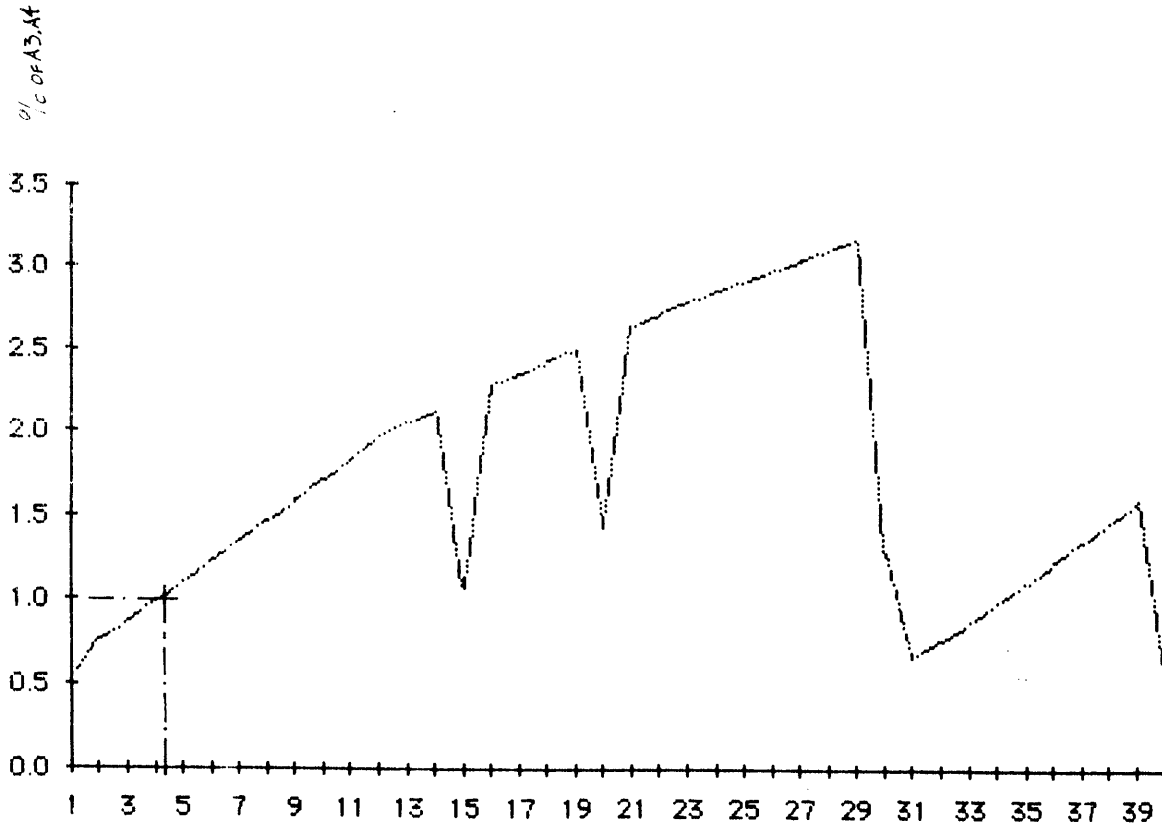

--- % of A3/A4 Built

SUPPLEMENTARY INCOME

The Idea

There is nothing original about this idea; it is practiced all over the country in different forms. Essentially I am speaking of the owner-occupied multifamily house. In this strategy there are two users: an owner-occupant, and a tenant(s). The tenant lives in a part of the house while the owner lives in the other half. Because of the increased space requirements this would require a larger initial investment, but the benefits of having a tenant are clear. The tenant's rent can be put contributed toward the owner's mortgage. Therefore, an owner who otherwise may not have had the opportunity to own a house can now own one with the aid of a tenant.

The fact that the owner is also an investor in the tenant unit allows the owner other benefits from the deduction, such as a depreciation deduction and larger interest deduction. Furthermore, the owner is leveraging a larger investment and could therefore benefit from a higher return upon sale.

Assumptions

- Two users will be occupying this building over its entire life -the owner and the tenant.
- The use and resources available to the owner are constant.
- The unit will be larger to accommodate two families and therefore will require a greater initial investment.
- The size of the unit was recalculated by pro-rating the initial cost per square foot for each component. The result is that the new unit would cost nearly \$100,000 versus \$73,000 for a single unit.
- The tenant pays rent equal to 125% of the market rate on a per square foot basis. This applies to all component groups.
- The owner depreciates only one half of the building, since only one half of the building is an investment.

- The components are financed and depreciated over terms equal to their lifetimes

The Results/Analysis

Although the initial input on this series is higher than on the norm, the consequences and benefits to the owner are very promising. The total input/output curve of this user makes housing to be made more affordable to the user. Over the lifetime, the input-output curve of the owner and the owner's available resources are closely linked.

The input required by the tenant is calculated at a rate of 125% of the market value on a per square foot basis. This was done recognizing that in many cases buildings are subsidized by tenants.

Even though this input/output curve correlates closely with input required by the building, and in fact in some areas shows the potential for profit, the user is required to have a large initial equity base in order to make the original investment. For people with little equity to begin with the chances of being able to accumulate that much equity initially are slim. However, given that the potential financial stability of this process is high, one wonders if it would not be possible for a loan or institution to require a lower initial downpayment, or else, allow some of the initial profits to be deferred as repayment to the bank.

Other ways to finance the initial downpayment, would be with a secondary mortgage, or by directing some of the surplus rent and future gain on sale to the lender.

Application

Designing this building as a nearly decomposable building, that is, where the interior walls and furniture (A.3 and A.4) could be moved without necessarily disturbing the structure of the building (A.2 and A.1) would allow a homeowner to change the size of the rental unit according to the owner's space needs. Thus as the owner's space needs increase the size of the owner's unit could expand while the tenant's unit contracts. Such an arrangement may be suitable for growing families who have little equity in the initial years. For instance, a couple buying a house could live

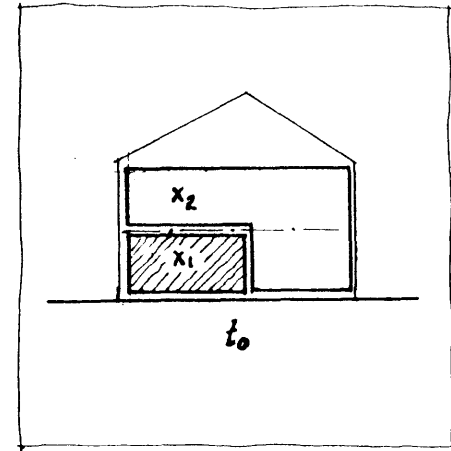

Supplementary Income at user's initial year
 X_1 = owner - occupant
 X_2 = tenant

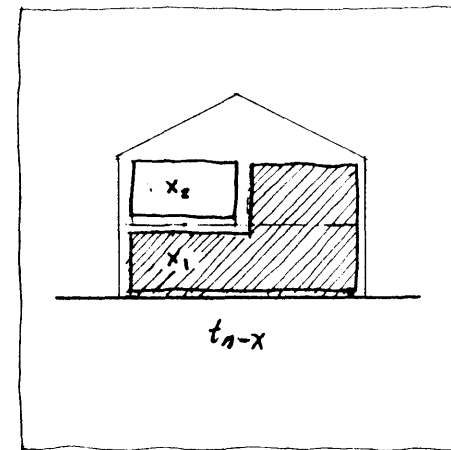

Supplementary income at midlife (t_n-x)

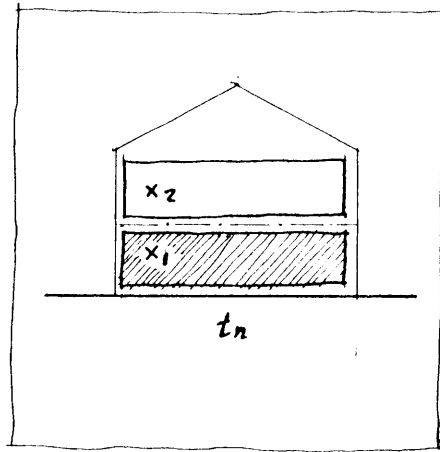

Supplementary Income during the User's Twilight Years (t_n)

live in a smaller portion of the building in the initial years and maximize the rental income; as their space needs and financial resources grew, the size of the rental unit could be decrease. As this family's space needs would began to contract in the twilight years of their lifecycle, the rental unit could be increased until the years of retirement when the rental unit would provide supplementary income to the owners.

All this would require would be to design into the buiding the ability to adapt and have the potential to be flexible with a minimum of cost. This can be accomplished by making each physical system more decomposable.

Input Required vs. Income Available

This graph shows the relationship between the input required by this Multi-user unit and the income available to the owner-occupant.

Because there will be more users in this unit than the standard house used on other strategies, this unit will be larger and therefore will require a greater number of initial payments.

In the first year the building will require nearly \$15,000 / Yr. using multiple financing. The Downpayment required by the user will be higher as well. Nearly \$10,000 will be required of the user in the initial year.

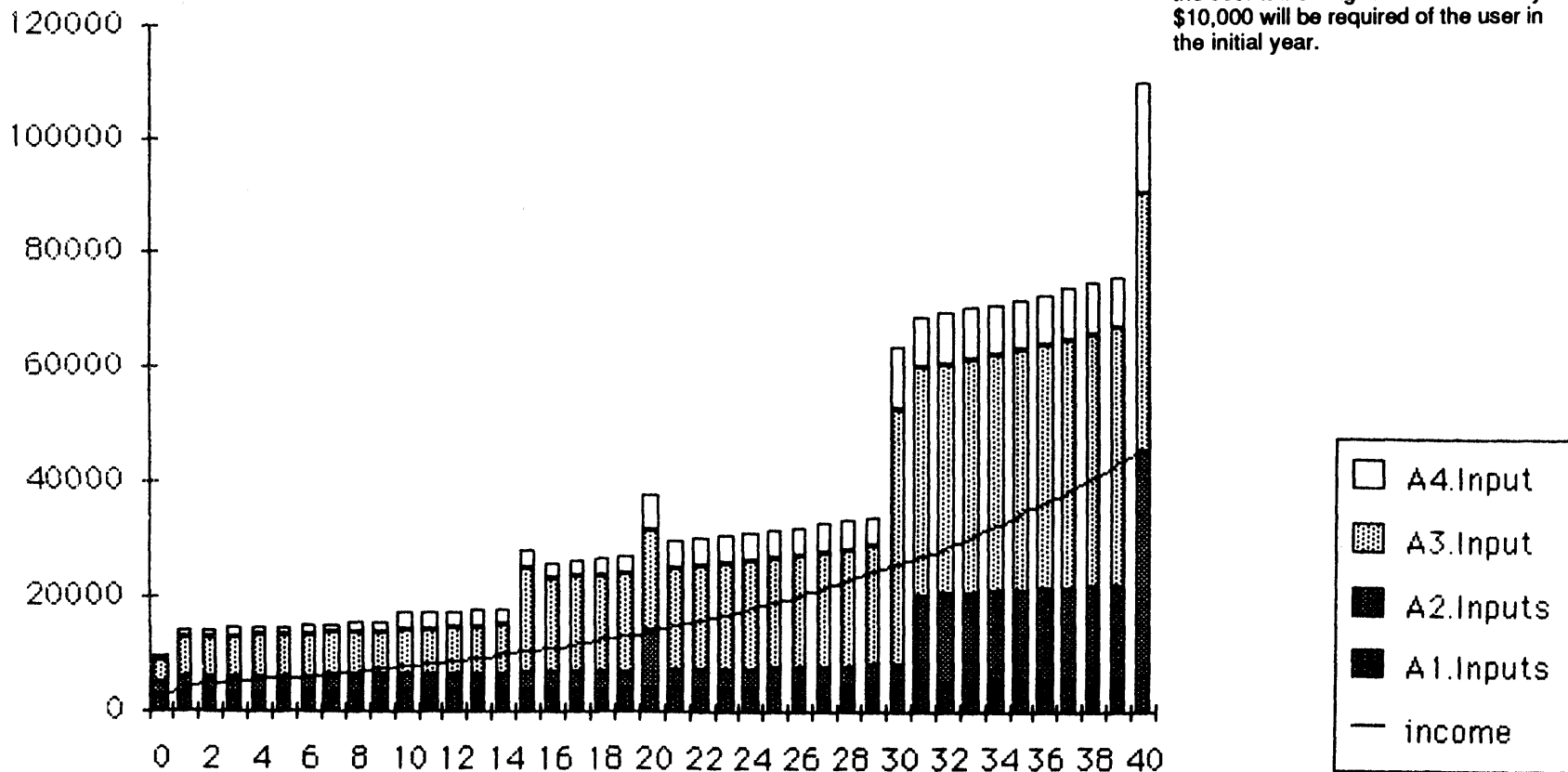

Input Required vs. Income Available during the First Ten Years.

With the average income used throughout the study it is clear that this family will be able to afford even less than before. It is only in the fifth year that the user will be able to afford the A.1 & A.2 units. However as we will see they will be the benefactors of greater benefits.

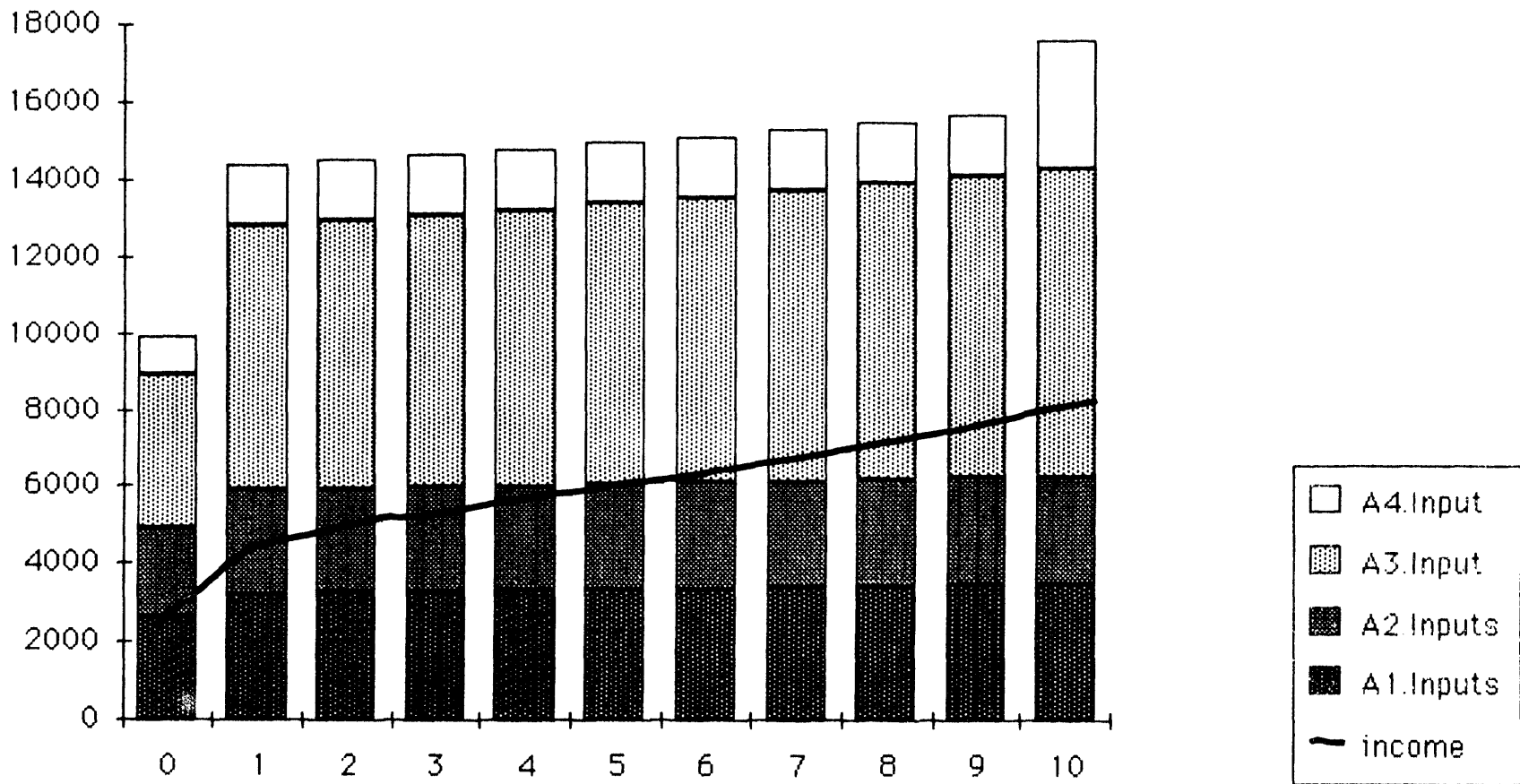

Available Income vs. Total User Input/Output.

This graph charts the relationship between the user's available income and the total input required minus the output received from the building.

The output that the user receives include rent, deductions on interest, and deductions on depreciation. Thus each time a new component is replaced and financed the user will be able to increase the size of the deductions due to the increased price of the component. This graph did not include the output of sale. Clearly since the user will be able to leverage a larger investment the size of the return on sale will be higher than in the standard model.

Clearly this model begins to close the affordability gap. However, one does need a larger initial investment which may be out of the reach of the typical user. One wonders, that in light of the fact that this option appears to perform so well over the lifetime of a building, whether banks would give out a second loan to make the initial payment.

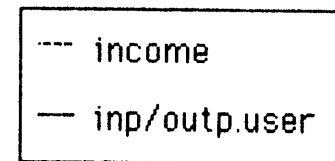
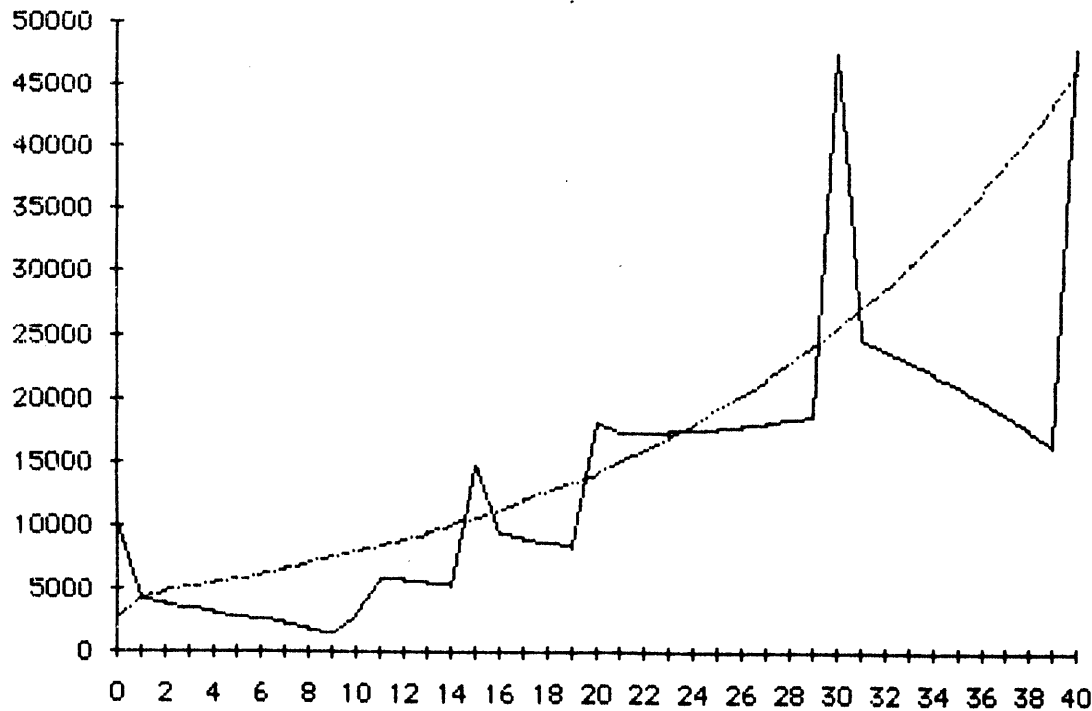

FLEXIBLE FINANCING

The Idea:

With the recent development and introduction of financial mechanisms in the finance world, it has become possible to incorporate different types of resources and devices which may not have previously been thought applicable. Variable rate mortgages, for instance, are designed to be sensitive to fluctuations in interest rates so that as inflation and market interest rates rise, the interest rate on variable mortgage can be adjusted accordingly. The shared appreciation mortgage rate, on the other hand, incorporates other potential resources as a means of paying the bank a return on their investment. The bank will charge a lower initial interest rate in return for a portion of the appreciation of the property upon sale.

One of the bank's primary goals is to assume its solvency. The commonly used return on investment that a bank requires will be a minimum of 3% over the inflation rate. Thus if the inflation rate is 6% in the year of the loan, the expected mortgage rate should be 9%. The theory does not always work out in practice. Since the bank will be committing itself to a loan over an extended period of time, during which the inflation rate and the interest rate could fluctuate rather radically, the bank must be able to protect itself from this consequence. The bank will therefore charge a higher initial interest rate. Variable mortgage rates, by virtue of the fact that they have the capacity to adjust to changes in the market, and since the user will be bearing some of the risk in the fluctuating interest rates the bank can charge lower initial interest rates.

The notion behind the flexible financing mechanism I wish to propose is as follows. Since in theory we have a reasonable understanding of how a building behaves economically over its lifetime, we can begin to speculate on what the input and the output for all these systems will be over the lifetime of the building. We can make adjustments over time as we begin testing the predictions with the actual costs incurred. Since we know that a lending institution requires a rate of return of 3% on the loan over the lifetime of the loan, I wish to propose the development of a mortgage instrument which can tabulate all the input and output of a building over its lifetime and

calculate a payment schedule which would both guarantee the lending institution a rate of return of 3% and be sensitive to the forces of inflation. This would reduce the premium a user would have to pay for simply securing the loan in the first place, for having to protect the bank against the forces of inflation. By discounting the value of the potential gains on sale in the future to contribute to the initial interest rate, the user could benefit from those future profits in the present, when the user is most likely dealing with financial hardships.

Thus every several years the original assumptions about the mortgage terms could be readjusted. For instance after five years of ownership it may appear that the building's maintenance costs and prospects for replacement could be moved forward from the dates originally assumed. If this is the case the premium on the sale would have to rise by an increment. Similarly if the original assumptions on the project's appreciation could not be realized, then the payments would have to be increased. Thus it would be in the user's best interest to ensure that the building's value and the value of the neighborhood is upheld in order to insure lower mortgage payments, since conceivably the payments could in part be determined by such determinants.

The lending institution would have to distribute the loans it sells so that it would be assured of a continuous rate of return from all its loan investments. If a bank's loans would all sell their projects in the 30th year, with no interim sales, the bank would be in a difficult position, having to assure its depositors the continued rates of return on deposits. It might be that the users would have to refinance the unit every several years so as to assure the bank its return.

This idea of a flexible mortgage instrument which would equalize payments relative all the buildings input and output and the user's capacity to pay for them, could still be useful even without the benefit of the discounted value of the proceeds from sale. The simple fact that the entire range of payments could be equalized over the lifetime of the system would be beneficial to the users, since they user would not have to bear such a high portion of the risk of fluctuating interest rates.

Assumptions:

-All initial lifecycle costs are calculated as they occur in their respective years. If an item needs to be replaced in year "x" it is registered as an input required of the building.

-All a buildings' output is calculated and tabulated. It includes:

Interest deductions on the debt.

Potential gain on sale

-The user owns the house after forty years including all its replacements and alterations.

-In the case of the mortgage instrument which includes the value increase as an input, the user is not entitled to any return on investment or any profit from appreciation, since this would be directed to the lender.

-The building's input are:

-Initial cost

-Lifecycle costs

-Replacement costs

-The income stream received by the bank would have to equal the payment required by the user to assure the bank a return of 3% above inflation. This was calculated by using the less than perfect IRR mechanism of evaluating a rate of return.

Results

This mortgage instrument was calculated using two different types of assumptions. The first one was calculated assuming that the appreciated value would not be included, while the second one was calculated assuming that the value of appreciation would be included as an input to the bank.

The results of the first mortgage instrument calculates a payment of \$8,700 while the second mortgage payment, which uses the resale value, is a slightly lower payment of \$7,300. Given the limits of the IRR as a device for calculating returns, we can see that the user will have a

continuous payment schedule. Ideally the payment schedule of the system could start out lower and rise with the users increase earning power.

Applications

These strategies could be applied in several ways. First, the proper equations for such a mortgage instrument would have to be developed. Some of the constraints of this instrument should take into consideration such aspects as fluctuations of interest rates, and changes in lifecycle costs. Ideally this mortgage instrument would also be able to be sensitive to the actual income pattern of the user as well as meeting the requirements of the bank.

The financing instrument would be applied to each component separately. This instrument would also have to be monitored every several years in order to readjust indexes and after and correct original assumptions. Thus if each component was financed separately, information from the past years as to the behavior that component could be used in determining the future indexes and assumptions, and the payment schedule could be reevaluated accordingly.

$$\begin{bmatrix} B_i \\ \vdots \\ B_j \end{bmatrix} \times \begin{bmatrix} I_{t_0} \\ \vdots \\ I_{t_n} \end{bmatrix} \times \begin{bmatrix} O_{t_0} \\ \vdots \\ O_{t_n} \end{bmatrix} \times \begin{bmatrix} R_{t_0} \\ \vdots \\ R_{t_n} \end{bmatrix} \times \begin{bmatrix} P_{t_0} \\ \vdots \\ P_{t_n} \end{bmatrix}$$

Flexible Financing

B_{ij} = Multiple
 Input = Input over time
 Output = Output over time
 $R_{ij t_n}$ = Return over time
 $P_{ij t_n}$ = Payment over time

Total Input required vs. Income Available.

This graph simply charted out all the input required by the building in the year of their occurrence. No financing was used. The input required are registered as they occur. This will be the basis for calculating a payment schedule.

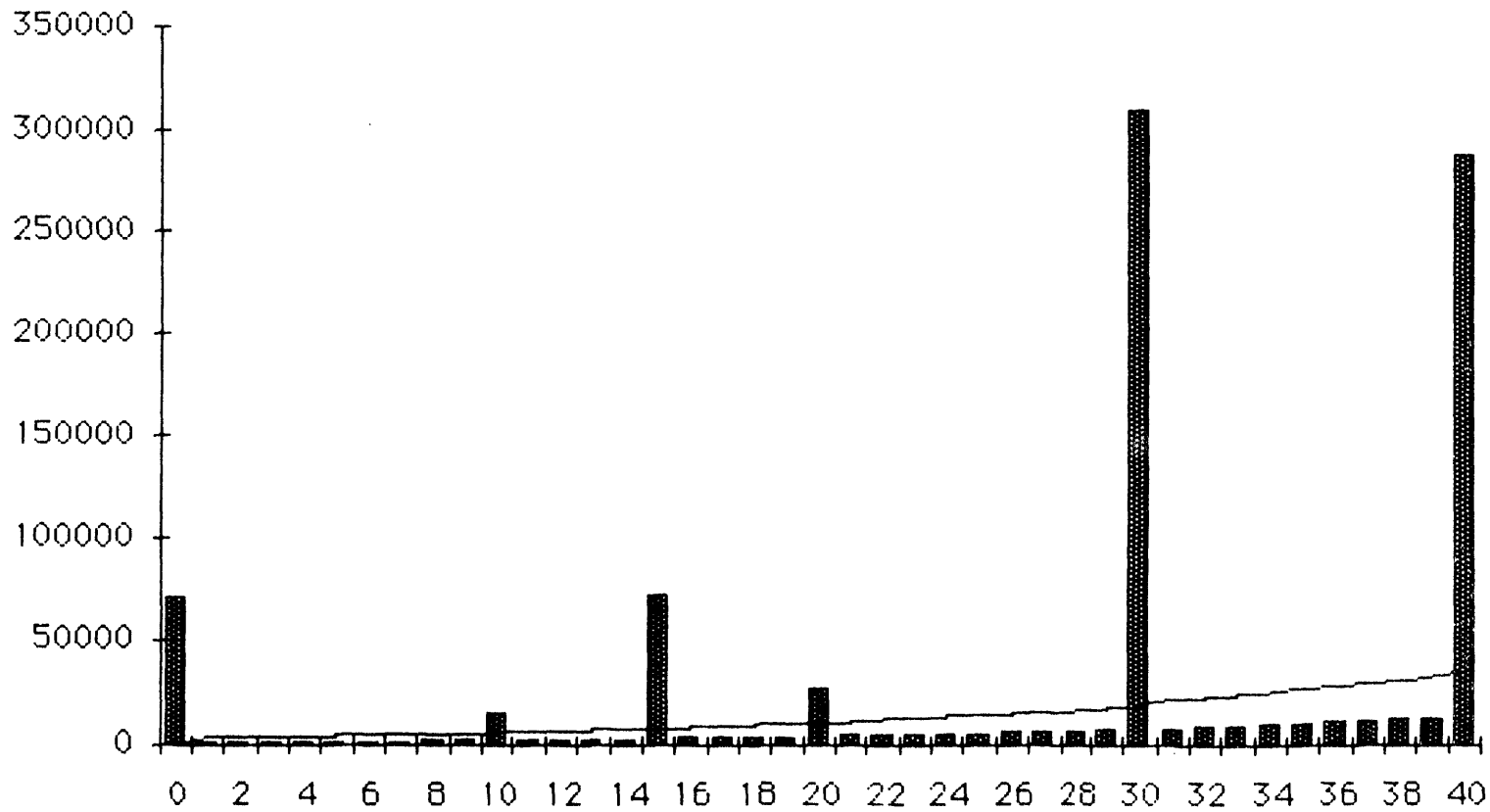

Income vs Input Required.

This graph projects what the yearly payment would have to be to guarantee the bank a yearly return of 3% above inflation.

The payment is calculated by discounting all the input and output from the building and calculating what the yearly payment would have to be in order to both guarantee the bank its return and repayment as well as meet the needs of the building.

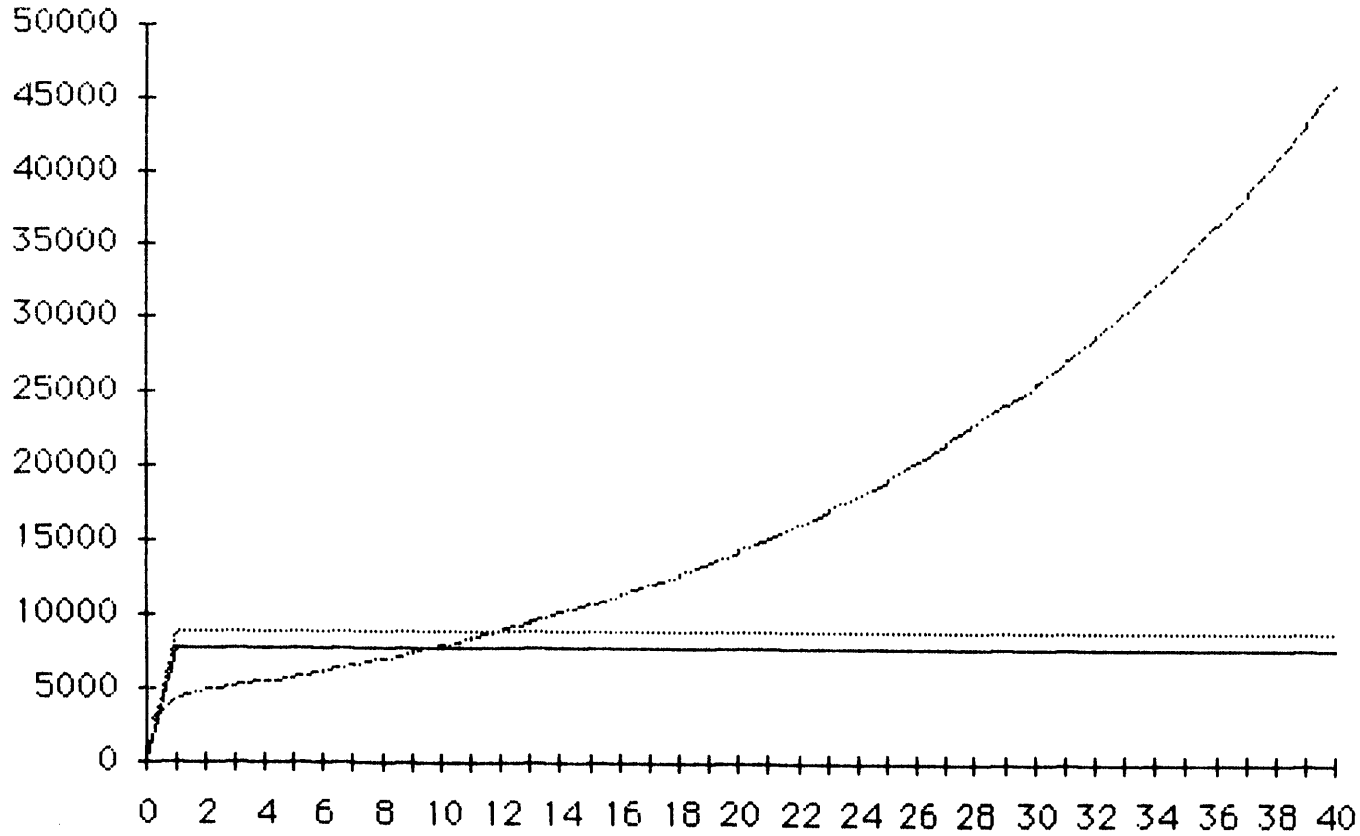

PART 4

SUMMARY OF THE STRATEGIES

Baseline Model:

- Housing is not affordable in the initial years to the baseline family.
- The inputs required of the building in the first year is \$9,300; the outputs available are equal to family modeled was \$4,500.
- Only in the middle years and final years is the building affordable, that is from years 12 to 28 and from year 31 onwards, is this the case.
- In year fifteen, twenty, and thirty, there are large replacement costs which affect the affordability of the project.
- Overall there is less debt paid by the user using the standard mortgage instrument as opposed any of the other strategies using multiple financing.

MULTIPLE FINANCING:

- Multiple financing is only affordable in the twenty-eight year.
- The first year costs are equal to \$10,300 per year versus \$9,300 for the normal mortgage instrument.
- The degree of unaffordability is more continuous than in any of the base-line models.
- The discontinuity created by replacement costs is less severe than in the base-line, since each replacement is financed separately and incrementally.

MULTIPLE OWNERSHIP

- The users affordability gap is reduced significantly from \$9,300 in the base-line model to \$7,300.
- The user can only own the A.3 and A4 systems , and is entitled to the deduction interest for those systems. The investor owns the longer depreciating components which require less maintenance and are more adaptable to different uses.
- The users' affordability curve deviates less from the available resources than the base-line model or the multiple financing curve.

- The investor realizes a handsome return on his investment. The investor has a continuous payment pattern, and profits in the form of rent, depreciation, interest deduction, and increased value.

PHASED CONSTRUCTION:

- If the user builds his own interior, the user will own 100% of the A.1 & A.2 systems and 73% of the A.3 in the initial year.
- If the user does not use their own labor, he will only be able to afford 37% of the A.3 system in the initial year.

SUPPLEMENTARY INCOME:

- The affordability of this strategy shows the most promise of all, but requires a higher initial downpayment.
- The users will require less income to afford the building over the lifetime of the building, although it will require more initial wealth.
- The only years in which the affordability curve comes in question is in the years of replacement, in the years 15, 20, and 30.

FLEXIBLE FINANCING:

- As diagramed the payments are constant over the lifetime of the building. The initial payments required to guarantee a bank a return of 3 % is equal to \$8,700 when not including resale value, and \$7,300 when including resale value.

ISSUES AND PROBLEMS

This thesis has attempted to discuss a conceptual framework which crosses over several professional boundaries, and in doing so it may illuminate old ideas in a new light as well as offer some new options. When the imposition of a new order or a new idea is placed within an existing context, undoubtedly questions arise as to how the two - idea and context- will merge. Will their fusion be convenient or forced? What are the chances of the idea finding root in the existing context? Will it fulfill needs not already furnished by existing sets of solutions?

Certainly more questions have been raised by this thesis than answered, and most of them revolve around the notion of implementation, since implementation represents the transformation of notion into reality?

General questions

- Who will implement these ideas and how will they affect existing actors and their roles? These actors include:

- Builders
- Developers
- Users
- Financiers
- Governments etc.

- How will it affect the existing roles of the users, institutions, and professions?
- How will assumptions on the behavior of the building systems be developed and how will they be altered with the realization of changing conditions?
- What are the implications of this conception of the problem on the design of physical systems?
- Can we design building in ways in which they are easier to change and alter where called for, and more permanent where needed?

•What is the extra cost if any of variability? Or otherwise stated; what is the cost of not designing for change?

Social systems.

- Will such building and design processes meet the needs of users in ways in which they do not already?
- If the options available to the users and consumers is increased several fold, will the users be overwhelmed by the complexity of the options available?
- How can all the options be packaged in a comprehensible format?

Builders

- How will the roles of the builders and developers be altered? What will the ramifications be for different trades operating on the same site at different times for different user, and under different contracts be?
- Who will bear responsibility for what?

Legal

- What legal and bureaucratic problems will this multi-user, multi-financed, nearly decomposable building raise?
- With the option of multiple ownership available, will the existing legal agreements commonly used be sufficient to deal with new conditions?
- Will the legal definitions of multi-ownership and multi-financed buildings be identical or isomorphic to the physical design of nearly decomposable systems?
- What existing building codes be amendable to notions of semi-complete buildings as is proposed the case in Phased construction?

- How will tax policy be affected by users using multiple loans and thus increasing the size of the federal subsidy over the life of the building?

Finance

- Will banks be willing to finance loans of different terms, to different users, in the same building?
- If one loan defaults how will it affect other loans within the same building?
- What will the ownership agreements be between the users?

Technology

- Will our existing data processing capacity be adequate to process all this information?
- How will the existing technology come to the aid of such a process and would it make the implementation of the process any more likely?

Design

- How can we design environments such that decisions made in any one of the building, finance and use systems can be incorporated into the whole decision making process?
- How would one design buildings, interiors, facades etc., which one knows will alter over time yet not knowing what the form of the forces acting on them will be nor knowing when they will occur or who will carry manifest them?
- How can buildings be designed so that their aesthetic principles will not be so fragile, so as to withstand the forces of time and in fact thrive on the forces of time and life?

Concluding Remarks

- Buildings do not have to be designed or constructed as assemblages of nearly decomposable systems, but if they are the physical space can be changed and altered according to the demands of the user and financial systems.
- Financing systems do not have to be variable, but if they are they can adapt to external conditions in the financial market and building systems.
- User systems do not need to be multiple or changeable, but if they are they allow the needs of the building and financial systems to be met.
- If each one of the above systems has the capacity to change to the needs of the other systems, each of them will be both more adaptive and more stable individually, and form an integrated Building-Finance-Use system.

As a designer I am concerned with the built environment and the way it changes. I am interested in change because it reveals the behavior of systems and informs us about our position relative to buildings, users, and history. An architecture which can change over time allows the folds of time to add richness to the environment. The capacity to change allows us to incorporate the idiosyncracies that occur in peoples lives, and in our institutions. Ultimately this is an expression of our society. The expression of change acts as a marker for our position vis-a-vis the world as well as history. We must, I believe, in a non-monumental architecture, allow the capacity for change.

Yet I look around and see a monolithic architecture: an architecture which runs contrary to the forces of society; an architecture which speaks of immobility, designed by architects who seek immortality. The paradox of an increasingly stolid physical, social and economic construct of reality emerging in a world which is in a state of flux can not be ignored. It presents dangers to the survivability of our environment, and of our society as a whole.

I am concerned about the way we develop our physical environment in the present socio-economic constructs of society. For instance, today's urban centers are identifiable by towers that are indistinguishable from the towers of other big cities. Each tower, each urban center, is rigid in its intended purpose and use as well as in the way it is physically designed and constructed to meet those needs. How will these towers, these cities, withstand the tests of time?

We know that the flow of energy changes within cities, as well as between cities. Today's vibrant city sections may be tomorrow's South Bronx. Likewise in the reverse case, yesterday's decayed urban areas are today's rehabbed areas. As the size and grain our cities becomes coarser, and the construct of our environment becomes more static, the chance of incremental and partial change taking place becomes less likely. Response to change cannot be realized until a critical moment when the physical construct cannot ignore the accumulated forces of change, but because of its size may be unable to adapt to the new external environment. Thus as the structure of our environment attempts to defy change by expressing impermeability, in reality it becomes more fragile. As buildings become both larger in size and more rigid in construction, they are more fragile to even the slightest fluctuations such that catastrophic doom becomes a possibility.

Thus as our built environment becomes a more monolithic manifestation of its building, financial and user systems, it become more fragile, subject to even the slightest discontinuities in external conditions.

We cannot predict the future, yet we know that change will occur. When change does occur, it will not necessarily be in a continuous fashion but in a discontinuous fashion, since, by definition, continuous change would be no change. To deny the fact of change is both fatalist and foolhardy. I do not claim that architecture should be as an ameba, ever transforming to the force of change with no internal structure other than motion to change itself. We must consider

creating environments in which the forces of permanence provide the armature for incremental changes of large and smaller scale in response to fluctuations in external and internal conditions.

This is an option which both allows an architecture of "being and becoming," an architecture asserting permanence, yet embracing change, an architecture of fragments and an architecture of wholes, an architecture of both/and, not an architecture of exclusivity. By thinking of buildings as nearly decomposable systems, decomposable systems which are designed, constructed, deconstructed, reacted to, embellished and/or deserted by different designers, users, over different time frames, it is possible to create an architecture of being and becoming.

What is the role of the architect in creating such an architecture, an architecture which is one of both being and becoming? The architect can only express what is to be reacted against. The architect does not design all forms of expression for all eternity. The architect acts as an aid to expression, The users are active determinants of this new expression, an expression which evolves over time as the internal forces of the designed system change and external forces of context change. The architect then allows the designed ensemble of form, finance and use to transform over time.

BIBLIOGRAPHY

Bruegman, William B. and Leo D. Stone, M.B.A., J.D., Real Estate Finance. Richard D. Irwin. Inc., Homewood, Illinois, 1981.

Dasso, Jerome and Gerald Kuhn, Real Estate Finance. Prentice-Hall, Inc., Engelwood Cliffs, New Jersey, 1983.

Dell'Isola, A.J., and S. J. Kirk, Life Cycle Costing For Design Professionals, New York: McGraw Hill, 1981.

Dell'Isola, A.J., and S. J. Kirk, Life Cycle Cost Data, McGraw-Hill Book Company, N.Y. 1983.

Dodge, Dodge Digest of Building Cos and Specifications, 1983, McGraw Hill Cost Information Systems, Princeton, N.J., 1983.

Habraken, Nicholas J., Transformation of The Site, Atwater Press, Cambridge, MA, 1983.

Habraken, N.J., The Grunfeld Variations, Labrotory of Architecture and Planning, M.I.T., Cambridge, MA. 1981.

Means, Means Systems Costs, 1983, Robert Snow Means Company, Inc., Kingston, Ma. , 1983.

Modigliani, Franco and Donald R. Lessard, New Mortgage Designs For Stable Housing in an Inflationary Environment, Federal Reserve Bank of Boston, Boston, MA, 1975.

Nutt, Ben, Walker, Bruce, Holiday, Susan, Sears, Dan, Obsolescence in Housing, Saxon House, Westmead, Farnborough, Hants, England, 1976.

Rossi, Peter H., Why Families Move, Sage Publications, Beverly Hills, 1980.

Simon, Herbert A., The Sciences of the Artificial, MIT Press, Cambridge, London, England, 1964.

Tempelmans Plat, Herman, Een Bedrijfs Economische Analyse Van Bouwen En Wonen, Vans Gorcen-Assen, 1984.

THESIS: (all MIT)

Cohn, Richard and Stanley Fischer, An Analysis of Alternative Non-standard Mortgages, MIT, 1974.

Cukiernan, Alex, Index Linked Mortgages In Isreal. MIT, 1975.

LaBreche, George J., Pricing and Financing of Transfer Equity in Cooperative Housing, 1972.

Wolf, Frederick Lewis, Cooperatives and Condominiums. A Financial Analysis, 1971.

APPENDIX

Level One: Starting Points

general.data.1

TEST MODEL #2 Feb.15

>>>

GENERAL DATA

Project name:	Standford Court	No of Units	72
Year of Data Origination	1978	Total initial Costs	1927586
Projected Year of Study	1983	Projected costs	

GENERAL DATAPROJECT SPECIFIC

No of Units	72	Market Rate Rents/Initial Yr	\$5220.00
Total Constr. Costs	2808000	Average SF/Unit	1350
Projected costs	3938365.3	Incr.Factor(init.yr to Pr.yr)	140.26%
Depreciable Base/Unit	43350.085		
Average Cost/SF	37.777852		
Average Constr. Cost /Unit	39000		
Land Costs	376000		

	\$	%	ProjIncr/Cat	Proj.Costs
Average Cost/ Unit- Sold	\$39000.00			\$54699.52
Manag/Development Costs	\$7000.00			\$9817.86
Land Cost /Unit	\$3000.00			\$4207.66
Interest/Financing Fees	\$2000.00			\$2805.10
Profit/Developer	\$0.10			\$0.14
Total Cost/Unit	\$51000.10			\$71530.28
Depreciable Base/Unit	\$43350.09			\$60800.74
Average cost/SF	\$37.78			\$52.99

Component *	Lifetime	unit.type	Units	Labor	Material	Equipment	Energy	Total	%Labor	Cost-Labor
Family A1										
Foundation	75	wsf.	360	0.017	0.0005	0.0001	0	6.336	96.59%	\$0.22
Primary str.	50		2400	0.04	0.02	0.005	0	156	61.54%	\$60.00
Primary Floor	50	sf	1300	0.017	0.005	0.001	0	29.9	73.91%	\$7.80
Prim. Stairs	40	flight	1	7	4	0	0	11	63.64%	\$4.00
Primary Roof	40	sf	650	0.04	0.01	0	0	32.5	80.00%	\$6.50
Utility Access			0	0	0	0	0	0	*DIV/0!	*DIV/0!
Remainder A1			0	0	0	0	0	0	*DIV/0!	*DIV/0!
Non-Bldg.Cost			0	0	0	0	0	0	*DIV/0!	*DIV/0!
Sub-Total								235.736		78.516
Family A2										
Non.Str.Ext.W	40	wsf	2400	0.02	0.01	0.001	0	74.4		
Roofs	20	rsf	780	0.011	0.003	0	0	10.92		
-Skylights	20	sf	0	0.4	0.05	0.02	0	0		
Windows	35	wsf	166	0.04	0.03	0	0	11.62		
Doors	40	wsf	42	0.19	0.08	0.03	0	12.6		
Decks/Balcon.	40	wsf	24	0.08	0.02	0.001	0	2.424		
RemainderA2			0	0	0	0	0	0		
Non-Bldg.cost			0	0	0	0	0	0		
Subtotal								111.964		
Family A.3										
InteriorWalls	20	wsf	2816	0.03	0.03	0.002	0	174.592		
Int.WallFin	0	wsf	2816	0.04	0.01	0.01	0	168.96		
Ceilg/FL./Fin	0	sf	1350	0.3	0.05	0.03	0	513		
Doors	20	wsf	142	0.23	0.08	0.021	0	47.002		
Kitchens			0	0	0	0	0	0		
Bathrooms			0	0	0	0	0	0		
Mech.Syst.	20	ea	1	150	20	4	0	174		
Electrical Sys.			0	0	0	0	0	0		
RemainderA3			0	0	0	0	0	0		
Non-Bldg.Cost			0	0	0	0	0	0		
Sub Total								1077.554		

Level Two: Lifetime Generators

SHEET A.1

% of Total Cost (Means)	27.00%	% of Non Building Costs	23.53%
% of Total Cost (Dodge)	36.00%	Total Cost	\$71530.28
		Downpayment	10.00%
		Total Rent.Val.	5220.2975

Component	Lifetime	Salvage Value	Initial Cost	LifecycleCost
Foundation	90	20.00%		\$6.34
Primary Structure	40	20.00%		\$156.00
Primary Floor	40	20.00%		\$29.90
Primary Stairs	40	20.00%		\$11.00
Primary Roof Structure	30	20.00%		\$32.50
Utility Access	40	20.00%		\$0.00
Remainder A.1	40	20.00%		\$0.00
Non-Building Cost	40	20.00%	\$4544.31	\$0.00
<hr/>				
SUB-TOTALS/AVERAGE	40	20.00%	\$19313.18	\$235.74

SHEET A.2

% of Total Cost (Means)	22.50%	% of Non Building Costs	23.53%
% of Total Cost(Dodge)	27.00%	Total Cost	\$71530.28
		Downpayment	10.00%
		Total Rent.Val.	5220.2975

Component	Lifetime	Salvage Value	Initial Cost	LifecycleCost
-Non-Struct.Wall	40	10.00%		\$74.40
-Roofs	20	0.00%		\$10.92
-SkyLights	20	10.00%		\$0.00
-Windows	35	10.00%		\$11.62
-Doors	40	20.00%		\$12.60
-Decks/Balconies	40	10.00%		\$2.42
Non-BuildingCost			\$3786.92	\$0.00
Remainder A.2		10.00%		\$0.00
<hr/>				
SUB-TOTALS/AVERAGE	30		\$16094.31	\$111.96

SHEET A. 3

% of Total Cost (Means)	40.50%		% of NonBuild"ngCost	23.53%
% of Total Costs (Dodge)	0.27		Total Cost	\$71530.28
			Downpayment	10.00%
Inflation Factor			Total Rent Value	\$5220.30
Component	Lifetime	Salvage Value	Initial Cost	LifecycleCost
Interior Walls	15			\$174.59
Int.Wall.Fin	15			\$168.96
Clg.Fl./Fin.	15			\$513.00
-Interior Doors	20			\$47.00
-Kitchens	15			\$0.00
-Bathrooms	20			\$0.00
-Mechanical Sys.	15			\$174.00
-Electrical/Lighting	15			\$0.00
Remainder A3	15			\$0.00
Non.Building.Cost	15		\$6816.46	\$0.00

SUB-TOTALS/AVERAGE	15		\$28969.76	\$1077.55

SHEET A.4

% of Total Cost (Means)	10.00%		% of Non-Bld'g.Cost	0.2352956
% of Total Cost(Dodge)	10.00%		Total.Cost	71530.279
			Downpayment	10.00%
Inflation Factor			Total Rental.Income	5220.2975
Component	Lifetime	Salvage Value	Initial Cost	LifecycleCost
-Furniture	10			0
-Appliances	10			0
-Loose Fixtures	10			0
-Temporary.Str	10			0
Remainder A.4	10			0
Non.Building.Cost	10		\$1683.08	0

SUB-TOTALS/AVERAGE	10		\$7153.03	0

A.I INPUT/OUTPUT GENERATOR

%ofValueIncr.		Interest.Rate	0.12	Depreciation	60	
Value.Incr.Factor	1	Mortg.Term	30	Accel.Factor	150.00%	
Init.Rent/A1	1409.4803	Rent.Factor	1			
Initial.Inflat.Index	1.06	1.06	1.1236	1.191016	1.262477	1.3382256
Headings	0	1	2	3	4	5

Foundation	0	\$6.72	\$7.12	\$7.55	\$8.00	\$8.48
Primary Str	0	\$165.36	\$175.28	\$185.80	\$196.95	\$208.76
Primary Floor	0	\$31.69	\$33.60	\$35.61	\$37.75	\$40.01
Primary Stairs	0	\$11.66	\$12.36	\$13.10	\$13.89	\$14.72
Primary Roof Str	0	\$34.45	\$36.52	\$38.71	\$41.03	\$43.49
Utility Access	0	\$0.00	\$0.00	\$0.00	\$0.00	\$0.00
Remainder A.1	0	\$0.00	\$0.00	\$0.00	\$0.00	\$0.00
Non.Building.Cost	0	\$0.00	\$0.00	\$0.00	\$0.00	\$0.00

Init.DownPayment	\$1931.32	\$0.00	\$0.00	\$0.00	\$0.00	\$0.00
Financing Costs	\$0.00	\$2157.85	\$2157.85	\$2157.85	\$2157.85	\$2157.85
-Interest	\$0.00	\$2085.82	\$2077.18	\$2067.50	\$2056.66	\$2044.52
-Remaining Debt	\$0.00	\$17309.83	\$17229.17	\$17138.82	\$17037.63	\$16924.30
Replacement Costs	\$0.00	\$0.00	\$0.00	\$0.00	\$0.00	\$0.00
Lifecyle.Costs	\$0.00	\$249.88	\$264.87	\$280.77	\$297.61	\$315.47
Poten.Tax.Ben.Int.	0	\$2085.82	\$2077.18	\$2067.50	\$2056.66	\$2044.52
Poten.Tax.Ben.Dep	0	\$273.60	\$273.60	\$273.60	\$273.60	\$273.60
Value.Increase.	0	\$1158.79	\$1228.32	\$1302.02	\$1380.14	\$1462.95
Potential Rent.Inc.	0	\$1494.05	\$1583.69	\$1678.71	\$1779.44	\$1886.20
Total.InputsRequirec	\$1931.32	\$2407.73	\$2422.72	\$2438.61	\$2455.46	\$2473.32
Total.Pot.Tax.Ben	\$0.00	\$2359.43	\$2350.78	\$2341.10	\$2330.26	\$2318.12

SHEET B.1 FINANCIAL RESOURCES OF THE INDIVIDUALS

Income factor	100.00%					
Init.inflat.	6.00%	Inflation	1.06	1.06	1.1236	1.191016
			year	1	2	3

B.1	Initial Income	Initial Assets			
-SinglePerson			0	0	0
--Subtotal Income					
--% of Income on Housing					
-- Tax Bracket					
B.1a-x					
-SinglePerson					
-Dependant.a					
-Dependant.b					
-Dependant.c					
--Subtotal Income					
--% of Income on Housing					
--Tax Bracket					
B.2					
-Couple.Per.1	16000	10000	16000	17977.6	19056.256
-Couple.Per.2	0	0	0	0	0
-Dependant.a	0	0	0	0	0
-Dependant.b	0	0	0	0	0
-Dependant.c	0	0	0	0	0
--Subtotal Income	0	10000	16000	17977.6	19056.256
--Income tax.Bracket (%)	25.00%	25.00%	25.00%	25.00%	25.00%
--% of Income on Housing	28.00%	28.00%	28.00%	28.00%	28.00%
B.3			0	0	0
-B.1			0	0	0
-B.1			0	0	0
-B.1			0	0	0
-B.2			0	0	0
-B.2			0	0	0
--Subtotal Income			0	0	0
--% of Income on Housing					
--Tax bracket					

Level Three: Synthesis

Component	0	1	2	3	4
Family A.1/Owned by:	1	1	1	1	1
Sub-Total Inputs	1931.3175	2407.7275	2422.7204	2438.6127	2455.4587
-Additions/Alterations	0	0	0	0	0
Total Inputs					
Potential Interest Deduction	0	2085.8229	2077.18	2067.4999	2056.6582
Potential Depreciation Deductic	0	273.60332	273.60332	273.60332	273.60332
Potential Value Increase	0	1158.7905	1228.3179	1302.017	1380.138
Potential Rent.Inc.	0	1494.0492	1583.6921	1678.7136	1779.4365
Total.Pot.Tax.Ben	0	2359.4262	2350.7833	2341.1032	2330.2615
Realized Value Increase					
-Total Outputs					
Family A.2/Owned By	1	1	1	1	1
Sub-Total Inputs	1609.4313	1916.888	1924.0089	1931.5571	1939.5581
-Additions/Alterations	0	0	0	0	0
Total Inputs					
Potential Interest Deduction	0	1738.1858	1730.9833	1722.9166	1713.8818
Potential Depreciation Deductic	0	456.00553	456.00553	456.00553	456.00553
Potential Value Increase	0	965.65876	1023.5983	1085.0142	1150.115
Potential Rent.Inc.	0	1174.5669	1319.7434	1398.928	1482.8637
Total.Pot.Tax.Ben.	0	2194.1913	2186.9888	2178.9221	2169.8874
Realized Value Increase					
-Total Outputs					
Family A.3/Owned By:	1	1	1	1	1
Sub-Total Inputs	2896.9763	4378.9783	4447.5108	4520.1551	4597.1582
-Additions/Alterations	0	0	0	0	0
Total Inputs					
Potential Interest Deduction	0	3128.7344	3115.77	3101.2498	3084.9873
Potential Depreciation Deductic	0	1641.6199	1641.6199	1641.6199	1641.6199
Potential Value Increase	0	0	1842.4769	1953.0255	2070.2071
Potential Rent.Inc.	0	2241.0737	2375.5382	2518.0704	2669.1547
Total.Pot.Tax.Ben	0	4770.3543	4757.3899	4742.8697	4726.6072

Family A.4/Owned By:	1	1	1	1	1
Sub Total Inputs	715.30279	799.20274	799.20274	799.20274	799.20274
-Additions/Alterations	0	0	0	0	0
Total Inputs					
Potential Interest Deduction	0	772.52701	769.32592	765.7407	761.72526
Potential Depreciation Deductic	0	608.00737	608.00737	608.00737	608.00737
Potential Value Increase	0	429.18167	454.93257	482.22853	511.16224
Potential Rent.Inc.	0	553.35154	586.55263	621.74579	659.05054
Family Data					
-Total Income	10000	16000	17977.6	19056.256	20199.631
-Income Tax Bracket	0.25	0.25	0.25	0.25	0.25
-Max. % Payments/Housing	0.28	0.28	0.28	0.28	0.28
-Max. payments	\$2800.00	\$4480.00	\$5033.73	\$5335.75	\$5655.90
-Potential rental income	\$0.00	\$0.00	\$0.00	\$0.00	\$0.00
-Total Payments Required	\$7153.03	\$9502.80	\$9593.44	\$9689.53	\$9791.38
-Total Potential Tax Benefits	\$0.00	\$7725.27	\$7693.26	\$7657.41	\$7617.25
-Dollar Value of Tax Benefit	\$0.00	\$1931.32	\$1923.31	\$1914.35	\$1904.31
-Potential Gain on Sale	\$0.00	\$3519.29	\$3730.45	\$3954.27	\$4191.53
Total Inputs/Outputs	\$7153.03	\$7571.48	\$7670.13	\$7775.18	\$7887.06
Total INP/OUTP.w/Val.Incr	\$7153.03	\$4052.19	\$3939.68	\$3820.90	\$3695.53
Investors					
-Tax Bracket	50.00%	50.00%	50.00%	50.00%	50.00%
-Payment Required	0	0	0	0	0
-Rental income	\$0.00	\$0.00	\$0.00	\$0.00	\$0.00
-Return on Sale	\$0.00	\$0.00	\$0.00	\$0.00	\$0.00
-Total Pot. Tax Ben.	\$0.00	\$0.00	\$0.00	\$0.00	\$0.00
-Dollar Value Tax Ben	\$0.00	0	0	0	0
TOTAL INPUTS - BUILDING	\$7153.03	9502.7966	9593.4428	9689.5277	9791.3777
TOTAL OUTPUTS - BUILDING	\$0.00	\$5450.61	\$5653.76	\$5868.63	\$6095.84
INPUTS PAID BY USER	7153.0279	9502.7966	9593.4428	9689.5277	9791.3777
OUTPUTS RECEICVED-USERS	0	1931.3175	1923.3148	1914.3518	1904.3131
OUTPUTS REQ.-TENANTS	0	0	0	0	0
INPUTS PAID - INVESTORS	0	0	0	0	0
OUTPUTS RECEIVED-INVEST.	0	0	0	0	0