

definitions of dwelling

by

Victor Wayne Olgyay
Bachelor of Science in Environmental Design
Antioch University, Yellow Springs, Ohio, 1980

Submitted to the Department of Architecture in partial fulfillment of
the requirements of the degree Master of Architecture at the
MASSACHUSETTS INSTITUTE OF TECHNOLOGY
June 1986

©Victor Wayne Olgyay 1986

The author hereby grants to M.I.T permission to reproduce and to
distribute publicly copies of this thesis document in whole or in part.

signature of the author
Victor Wayne Olgyay
Department of Architecture
May 9, 1986

certified by
John Randolph Myer
Professor of Architecture, Head of the Department
Thesis Supervisor

accepted by
Thomas Chastain
Chairman, Departmental Committee for Graduate Students

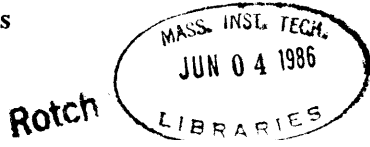

**many thanks for the advice and encouragement of my
readers, Nabeel Hamdi and Sandra Howell**

definitions of dwelling

by

Victor Wayne Olgyay

Submitted to the Department of Architecture on May 9, 1986 in partial fulfillment of the requirements for the Degree of Master of Architecture

Thesis Supervisor: John Randolph Myer
Title: Professor of Architecture, Head of the Department

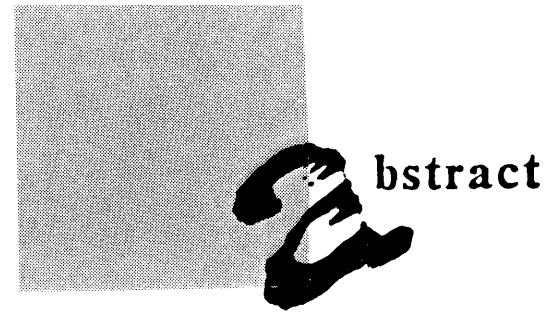

Home is an elusive concept. In one manner it is highly specific and individual in its definition, and in other aspects it is ubiquitous, present in our every act. In this thesis I explore several possible definitions of dwelling originating from the different relationships between the observer and environmental meaning.

The meaning of dwelling is examined in four manners: case studies, interviews, academic research, and a small design project. The relationship of vernacular and formal architectural ideas are compared, and shown in the context of the user. In this way the degree and manner in which architecture influences the nature of dwelling is shown.

It is my contention that architecture is but a subset of the manifold influences on dwelling. Architecture can assist dwelling by careful encoding of activity oriented meanings, but it is only through the user's inhabitation that dwelling truly occurs.

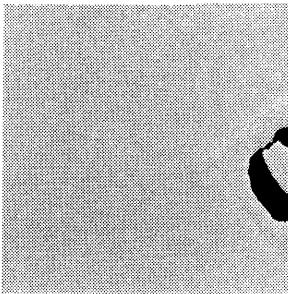

ontents

Abstract	3
Introduction	7
1 An american dream	13
2 Dwelling in a house	19
3 Order out of chaos	25
4 Levels of meaning	29
5 Building dwelling	45
6 Transformation	69
7 The worlds in a city	93
8 Ch ch ch ch changes	107
Conclusion	115
Bibliography	119
Appendix	
A: Transcriptions Of Interviews	123
B: CALPAS Input Data	171

"Sally told me about it, yeah, how this goldfish she had in a little glass of water, you know like you get at the midway, well this fish of hers croaked and she couldn't face it. So it was floatin' around in the bowl and she said "Chris! Please!" and he grinned and took the fish and was off. I guess most folks woulda head for the john or something but not this wild man. So he starts climbing up all over these desks and pipes, chairs, balconies, ducts and up on the wall till he's up by the crack where the wall meets the ceiling and he finds this little niche that not even the painters saw and this little niche is just about the size of this little dead fish so there it stays.

And it's pretty funny, this little secret. Sometimes I go in that room and try to remember just where it is, but I can't see it. But I know it's there. Buried just by being high."

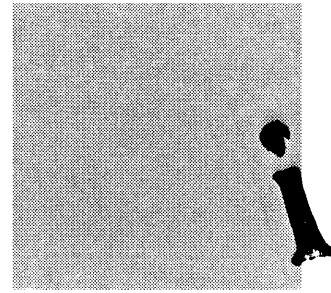

Introduction

"When the environment is meaningful, man feels at home". -Norberg-Shultz (1)

concept/intention

Home is an elusive concept. In one manner it is highly specific and individual in its definition, and in other aspects it is ubiquitous, present in our every act. In this thesis I explore several possible definitions of dwelling originating from the different relationships between the observer and environmental meaning. In this way the degree and manner in which architecture influences the nature of dwelling is shown.

It is my contention that architecture is but a subset of the manifold influences on dwelling. Architecture can assist dwelling by careful encoding of activity oriented meanings, but it is only through the user's inhabitation that dwelling truly occurs.

methodology

methods of investigation

constituant categories of interaction

	<i>1) Academic Research</i>	<i>2) Case Study Observations</i>	<i>3) Architectural Design Investigations</i>	<i>4) Interviews with Laypersons</i>
<i>a) the Built Environment and the Architect</i>		<i>chapter 5</i>	<i>chapter 6</i>	
<i>b) the Built Environment and the Layperson</i>		<i>chapter 5</i>		
<i>c) the Cultural Environment and the Layperson</i>	<i>chapter 1</i>			<i>chapter 7</i>
<i>d) the Cultural Environment and the Architect</i>	<i>chapter 2</i> <i>chapter 3</i> <i>chapter 4</i> <i>chapter 8</i>			

methodology

Architects and laypersons have often considered different aspects of dwelling to be of paramount importance. In order to account for this difference of opinion, both the cultural environment and the built environment must be examined. My interpretation of this set of relationships between the observer and environmental meaning identified two observers, (the architect, and the layperson) and two subjects: the built environment and the cultural environment.

Arranging these into a matrix, I have arrived at four compound categories, each of which has its attributes in typology of investigation.

- a) the Built Environment and the Architect.
- b) the Built Environment and the Layperson.
- c) the Cultural Environment and the Layperson.
- d) the Cultural Environment and the Architect.

These categories of observer and subject each have distinct characteristics which lend themselves to different methods of investigation. In this instance, four types of investigation seemed particularly relevant for understanding the relationship between observer and subject.

- 1) Academic Research
- 2) Case Study Observations
- 3) Architectural Design Investigations
- 4) Interviews with Laypersons

In the category of an architect working with the built environment, the examination of dwelling was done as a design project, as well as by looking at case studies of the built work of other architects (chapters 5 & 6). Case studies of vernacular building forms comprise the category of laypersons and the built environment (chapter 5). The interaction of laypersons and the cultural environment was done in a series of interviews which focused on personal

interpretations of dwelling (chapter 7). Finally, this investigation begins with academic research and conjecture by an architect on the relationship of meaning to the cultural environment (chapters 2,3,4 & 8).

Chapter one is entitled "an american dream" and is a brief introduction to the detached single family dwelling which sets the context for the further interactions of observer and environmental meaning. In chapter two, "dwelling in a house", the concept of dwelling in its existential nature is investigated, dwelling as a meaningful interaction between a person and a location is considered. "Order out of chaos" is the title of chapter three; this chapter is concerned with the definition of meaning and its legibility in the environment. Chapter four is called "levels of meaning" and in many ways provides the foundation for evaluating how meaning is embodied in physical material. The concepts of concrete meaning, activity oriented meaning, and symbolic meanings are introduced, defined and discussed. Chapter five shows examples of how these different levels of meaning occur in the built environment. Entitled "building dwelling"; four case studies are presented in this section, two architect designed examples and two builder / vernacular examples. Chapter six,

"transformation" graphically expands on the relationship of architects to the built environment; the transformation of a builder's Cape cod cottage is the focus of an architectural design exercise, which explores activity related definitions. Chapter seven embraces subjectivity, consisting of excerpts and analysis of a series of interviews with laypersons concerning dwelling. Chapter seven is entitled "the worlds in a city". Chapter eight, "ch ch ch ch changes" focuses on the relationship of values and time as dynamic influences on the definition of dwelling. This somewhat complex set of approaches is meant to be inclusive by nature, and in this manner displays the proportionate role architecture plays in the definition of dwelling.

constraints and allusions

In order to provide a description of these various attitudes towards defining dwelling without analytically dissecting the subject, I have adopted the following system of constraints and allusions.

As previously mentioned, the initial constraint is the somewhat arbitrary focus of the discussion on the detached single family dwelling. The detached single

family dwelling has been noted as particularly irrelevant to contemporary housing concerns, however I find the detached single family dwelling to be a delightfully discrete dwelling "type" which embodies most all of the issues with which I am concerned. In a similar vein, this discussion is generally based on the New England dwelling types with which I am most familiar.

A general formmaking principle governing this thesis is one of attitude. I believe in Hesienberg's uncertainty principle as applied to prose; therefore I find it often counterproductive to directly confront issues, lest you create your discoveries. I prefer to discuss relevant material inconclusively, and allow conclusions to emerge in the readers mind. This has two implications. Much of the material presented here is collected from disparate original sources in order to maintain the material's individual integrity. It is in the organization and presentation of this thesis that my subjectivity appears. Secondly, this is not meant to be a definitive document by any means, the material is observational in character and not intended as applicable design information. This document is an outline of my methodology, and perhaps an inspiration for continued musings on this matter.

"All we communicate to others is an orientation towards what is secret without ever being able to tell the secret objectively. . . . Paradoxically, in order to suggest the values of intimacy we have to induce the reader into a state of suspended reading. For it is not until his eyes have left the page that recollections of my room can become a threshold of onerism for him." (2)

notes

- 1) C. Norberg-Schultz Genuis Loci , pg 23
- 2) G.Bachelard, The Poetics of Space ,pg 14

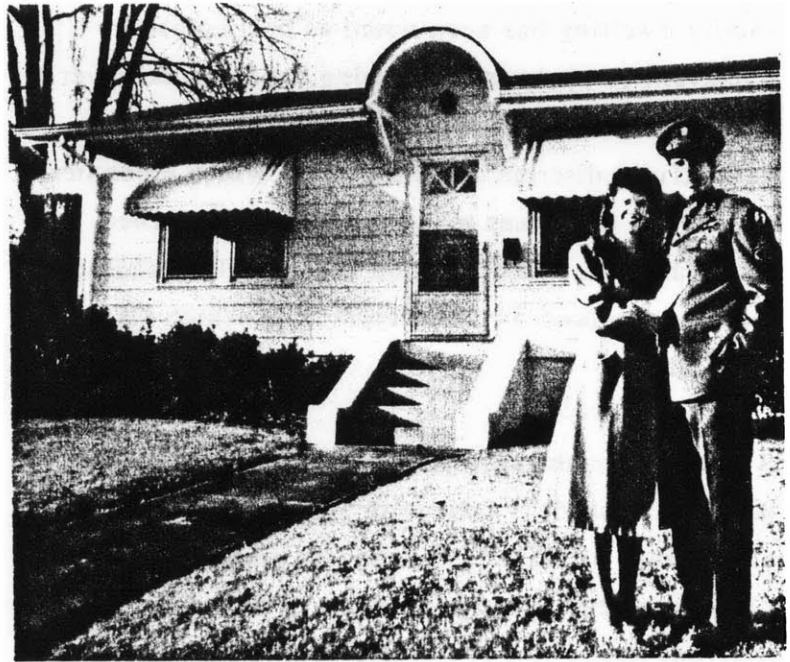

an american dream

symbol of success

To many people, the detached single family dwelling epitomizes their concept of the ideal living situation. Much of this may be attributed to its marketing and the associations historically attached to the detached single family dwelling, and some may have to do with its intrinsic value. The following discussion explores some of the symbolism and limitations of the detached single family dwelling.

The house is a very tangible symbol of success, and the residence is regarded as a goal and a symbol, as well as something to live in. The majority of United States citizens regard the purchase of a dwelling as one of the major goals of life. With such importance attached to this idea, it is worth briefly examining why such a large percentage of the United States citizens consider the detached single family dwelling to be ideal.

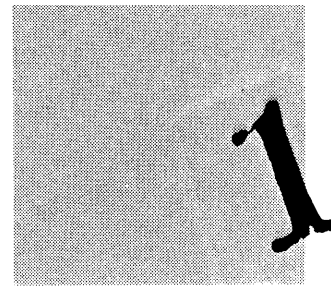

commification

The United States evolved from the colonies to a dispersed, agrarian "frontier" which today includes suburbia. There was at one time a striving to define the ideas and physical forms which represented a truly "american" culture. In Jefferson's time the United States was predominately detached single family dwellings, and the ideal american home became symbolized as the independent homestead, agrarian and self-sufficient. This concept proved to be remarkably easy to commodify as it maximized incentives to private enterprise. By the 1850's commonly available "pattern books" provided explicit inspiration for the american dream.

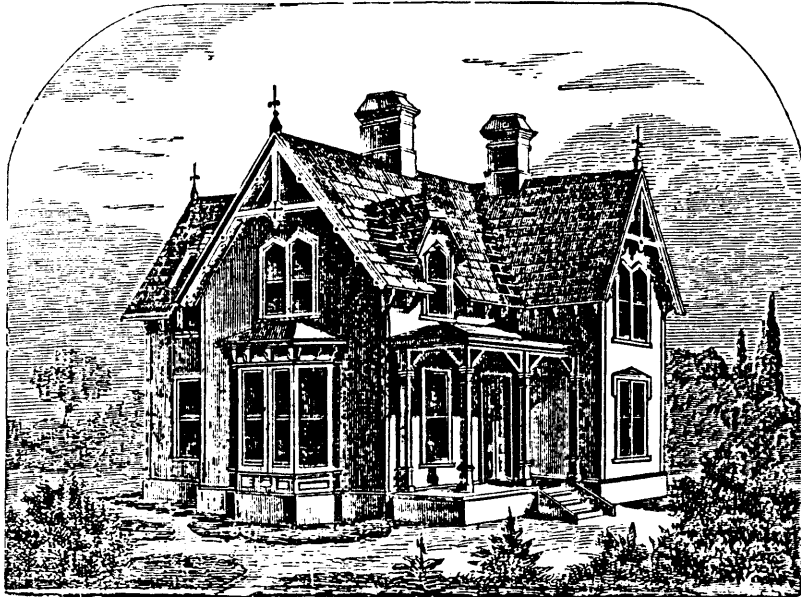

PERSPECTIVE VIEW.

"Each pattern book drawing showed a single, isolated dwelling surrounded by a carefully tended garden... on an individual level they represented personal independence. On a social level they showed family pride and self-sufficiency. Politically, the architecture seemed an expression of democratic freedom of choice. And economically, it mirrored the pattern of private enterprise, rather than planning for the overall public good, which characterized American society." (1)

symbol of self

Following this desire for privatism is the expression of the individual. Private architecture has a distinctly public side, for in many ways the house is symbolic of the self. The degree of concern with the exterior of the house is indicative of the occupants concern with their public image. Boston's (ex) West End was perceived as a slum by outsiders, but not by the occupants who found it to be a quite congenial home neighborhood. Their lack of concern with their public face was indicative of an internal community understanding.

"I have always believed in being careful about my clothes; getting well dressed because then I could forget all about them. That is what should happen to you with a good house that is a HOME. When you are conscious that the house is right, and is honestly becoming to you, and you feel you are living in it beautifully, you need no longer be concerned about it. It is no tax upon your conduct, nor a nag upon your self-respect, because it is featuring you as you like to see yourself" (2)

Single family dwellings are somewhat different. Although there is often quite a conservatism in that all dwellings in a given area are of a similar type, this is contrasted by a high degree of self expression and individuality. No matter how innane, these personal touches are very important in establishing the individual identities of single family dwellings.

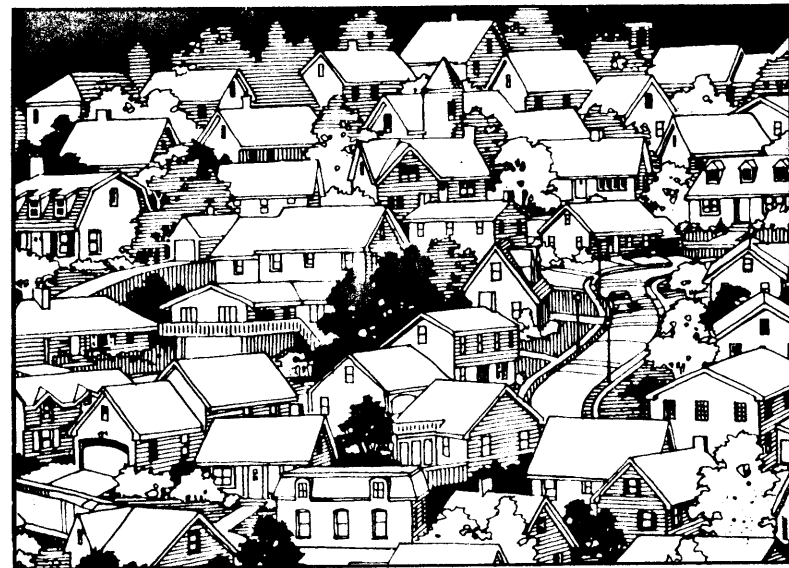

**Home-ownership costs
as percent of family income**

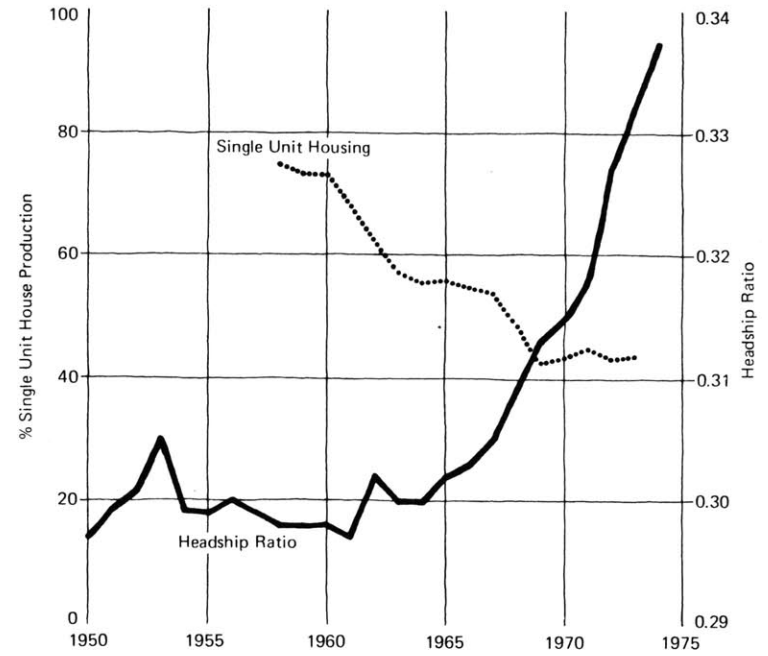
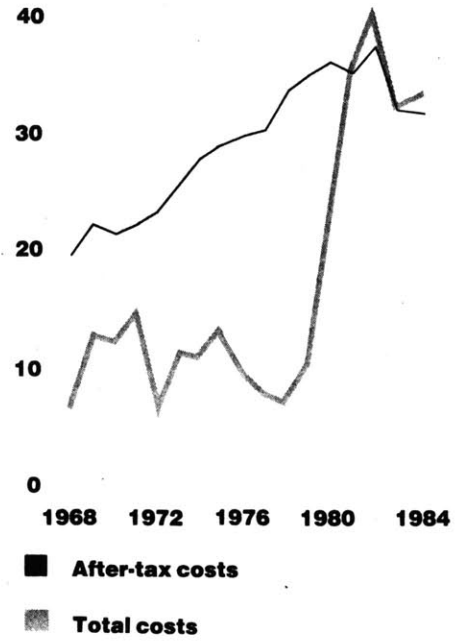

irrelevance

Many of the characteristics which helped commodify the single family dwelling in the 1850's are losing their relevance in the 1980's. The amount of agrarian workers has declined to a small percentage of the population, creating a more centralized workforce and less reason for a dispersed population. The so-called nuclear family, around which the detached single family dwelling was designed, is a steadily declining segment of the population, being rapidly replaced by elderly, single persons, etc., for whom the detached single family dwelling is less appropriate. The result has been a net increase in the "headship ratio", defined as the ratio of households to the total population. These smaller households have different needs than the nuclear family. (3) In addition, the economic climate has virtually foreclosed on the single family dwelling, making it much more of a dream than a fiscal reality for the majority of citizens. (4)

The future of the detached single family dwelling as the dominant domestic housing form in the U.S. looks bleak. What will emerge as appropriate and emblematic of the current U.S. cultural climate? It is not my purpose to speculate on that question, but rather to consider some of the information learned from the single family dwelling as applicable to other housing forms.

notes

- 1) Wright, Gwendolyn Building the Dream. MIT Press, pg. 88
- 2) Wright, Frank Lloyd The Natural House Horizon Press 1954, pg. 130
- 3) Davis, Sam The Form of Housing Van Nostrand Reinhold 1977, pg. 85
- 4) Mattill, John "Clamping a Lid on Homeowning". Technology Review, Feb./March, 1986, pg. 80

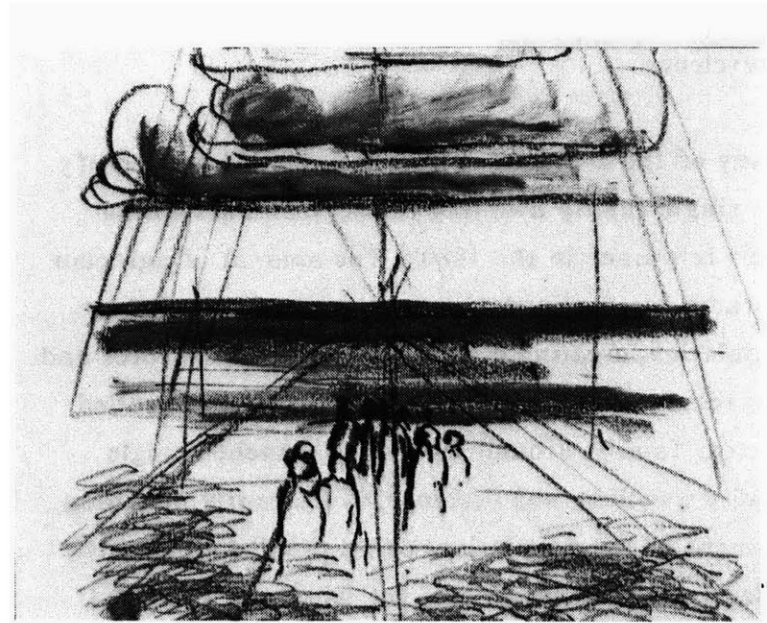

dwelling in a house

being in the world

Dwelling can be considered as a noun to be the physical shelter, or as a verb to be the animated act of being in the world. In this chapter the discussion of residences focuses on the concept of "dwelling" from the standpoint of the occupants interaction with the world. This examination addresses the questions "what is the minimum dwelling?" Is it simply shelter, i.e. a roof and space? Why could this minimum shelter not be repeated indefinitely and satisfy our needs?

As human beings we could live on simple basic foods, yet we constantly refine and elaborate the ritual of eating. I feel we approach dwelling similarly; the connotations and implications of our "settling" evolve a wealth of existential needs. Norberg-Shultz considers four "modes" of dwelling, designated as settlement, urban space, institution and house. Dwelling is as such thought to be the establishment of bonds between our selves and our environment in all these circumstances, an essential aspect of

"being-in-the-world."

"...this relationship consists of an act of identification, that is in a sense of belonging to a certain place. Man, thus, finds himself when he settles, and his being-in-the-world is thereby determined" (1)

Dwelling occurs concurrently with this sense of belonging. This association determines the relative nature of the minimum physical form. In a collective manner this environmental relationship creates settlements and urban space, places where people encounter each other, exchange ideas and celebrate their diversity. When agreements are collectively shared, institutions are the manifestation, with spaces and buildings allotted for the actualization of ideas. Public buildings and spaces are often explicitly symbolic in the beliefs that they embody, in an effort to "make the common world visible" (2)

The evolution and actualization of ideas on a non-collective (private) level is manifested in the individual dwelling. The house allows for isolation, and the development of personal identity. Therein lies the creation of the personal world. Here we will examine only the personal world, and that which underlies all of these modes: the concepts of orientation and identification.

orientation/identification

"Identification is related to form, whereas orientation approaches spatial order. We could also say that they correspond to the architectural functions of "embodiment" and "admittance". Any environment, thus, embodies meanings, at the same time it admits certian actions to take place." (3)

The process of identification is the perception of recognizable "things" in the world. As such it is dialectic, dependent on our interaction with the object, and the objects interaction with the environment. What is identified is thus to a large degree subjective, making the meanings embodied a personal interpretation. The universality within this experience is the idea that "through identification

man possess a world, and thereby an identity." This is the manner through which identification helps us dwell, by gathering the world relativisticly, and concretizing our understanding.

Orientation in our environment is essential for our emotional security. As such, it is dependent on our identification of things, but includes the cognitive aspect of creating an order from the environmental stimulus. In this "ordering" of our environmental information we cognitively build "domains" composed of paths and places (or places and places!) This spatial orientation is admitting, in that it allows us to live and take action in space. Regardless of whether orientation is considered as a cosmic ordering, axial, grid, radial, path/place, etc., it has as its basis an ordering and the evolution of a meaningful understanding which allows us to dwell.

home

When the personalization of identification and orientation occurs, that person is "at home". This is the initialization of meaning in the environment. This Heideggerian quality of "at home" is not limited to our recognition of environment, but rather

provides the basis for our understanding of it. As such, home is by no means limited to a single physical place. The single physical place "keeps" the cultivated personal identity as made concrete by things. This keeping of place can contain the etherial "presence" of occupancy evident. When we retreat to our home, we can "recover our personal identity". (4)

"in the house this immediate and unified world of mood and understanding becomes present. The house, thus, does not offer understanding in the sense of explanation, but in the more original sense of "standing under" or among things. In the house man experiences his being part of the world." (5)

house city landscape

The house is thus not apart from the world, it is the world of personal size, the microcosmos. "As a space within a space it repeats the basic structure of the environment. The floor is the earth, the ceiling the sky, and the walls the encircling horizon." As such there is the natural tendency to encourage the interaction of the house and the environment. Opening up the building to the environment allows a gathering

of the site, with its manifold meanings. As stated by Moholy-Nagy, "A dwelling should not be a retreat from space, but life in space". (6) A continuous range of definitions of earth, sky, and horizon may then create imagable spaces, at a public or private size. The world may then be considered a home.

"Make of each place, a bunch of places of each house and each city, for a house is a tiny city, a city a huge house." (7)

"This reciprocal house-city image leads to a consistent articulation of large and small both inside and outside in sequences of contingent units which interlock without stress or effort. When this articulation is carried through to the smallest dimension, not only buildings and cities acquire reciprocal meaning, but buildings and furniture also, because large scale pieces of built furniture are like small houses in which one feels yet more interiorized than in a large room. Thus each part is given the dimension which suits its purpose best, i.e., the right size through which it comes into its own." (8)

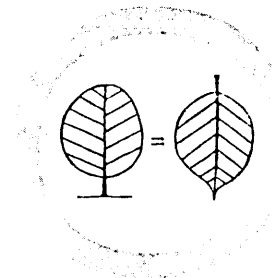

genus loci

According to ancient Roman belief every "independent" being has its genius, its guardian spirit. This spirit gives life to people and places, accompanys them from birth to death, and detirmines their character or essence... The Genius thus denotes what a thing is, or what it wants to be... Architecture comes into being when a "total environment is made visible", to quote the definition of Susan Langer. In general, this means to concretize the Genius Loci.⁽⁹⁾

By their physical location spaces "gather" different associative meanings. In interacting with these spaces we interperit further modify their meanings. Bachelard decribes this built genus loci as "topoanalysis", or the "systematic psychological study of the sites of our intimate lives" (10) Our memories as individuals and as cultures become located in spaces and demand certian associations. In a dwelling for example, the cellar might be understood to represent the irrational and the unconcious, dark and mysterious. It is the subterrannean aspect of our being. Up in the attic, rationalism is evident. We rise to the light, to the

view, and to survey our dominance over our surroundings. Between these two are connecting stairs, paths leading us, allowing us to through these spaces and between our moods.

It is vital for these pieces of our psyche to be housed; as whole persons they are with us and contribute to our well being. The forms, places and associations may change, but the existential needs of dwelling remain.

dwelling is an act

Following a discussion of genus loci it is relevant to note that the meaning embodied in a physical location is also affected by the physical process of creation. I describe this as the generation of place spirit.

Heidegger has noted the word dwelling has (in both English and German) evolved from the roots of the word "bild" meaning to build. Expounding on this, he offered the idea that "Building is really Dwelling"⁽¹¹⁾ and that it is only through creative action that dwelling can truly occur. Conversely, a person restricted from effecting change in their environment may not fully dwell.

In *The Poetics of Space*, Bachelard quotes Michelet on the creation of a nest.

"On the inside, the instrument that prescribes a circular form for the nest is nothing else but the body of the bird. It is by constantly turning round and round and pressing back the walls on every side, that it succeeds in forming this circle.... The house is a bird's very person; it is its form and its most immediate effort, I shall even say, its suffering. The result is only obtained by constantly repeated pressure of the breast. There is not one of these blades of grass that, in order to make it curve and hold the curve, has not been pressed on countless times by the birds breast, its heart, surely with difficulty in breathing, perhaps even, with palpitations" (12)

In this generative manner places gather meanings from the sweat of their creation. Less poetically, this does not require the manifestation of a new space being born, the process involved may be a memorable event in a given location. The critical aspect of the act of dwelling is the process of building meaning over time, in space.

notes

- 1) Norberg-Schultz *The Concept of Dwelling* Rizzoli, 1985, pg. 13
- 2) Ibid, pg. 13
- 3) Ibid, pg. 15
- 4) Ibid, pg. 89
- 5) Ibid, pg. 89
- 6) Ibid, pg. 103
- 7) Van Eyck, Aldo in *Aldo van Eyck*. Stichting Wonen, Amsterdam, 1982, pg. 49
- 8) Hertzberger, Herman, et. all *Aldo van Eyck*. Stichting Wonen, Amsterdam, 1982, pg. 12
- 9) Norberg-Schultz *Genius Loci* Rizzoli, 1980, pgs. 18, 23
- 10) Bachelard, G. *The Poetics of Space* Beacon Press, 1969, pg. 8
- 11) Heidegger, Martin *Basic Writings*. Harper and Row, 1977, pg.326
- 12) Bachelard, G. *The Poetics of Space* Beacon Press, 1969, pg.107

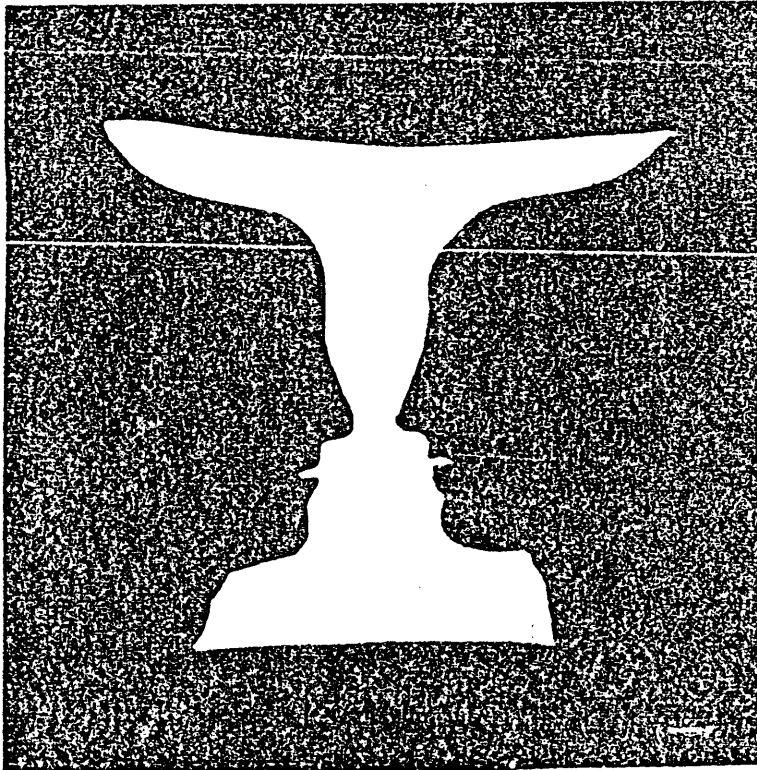
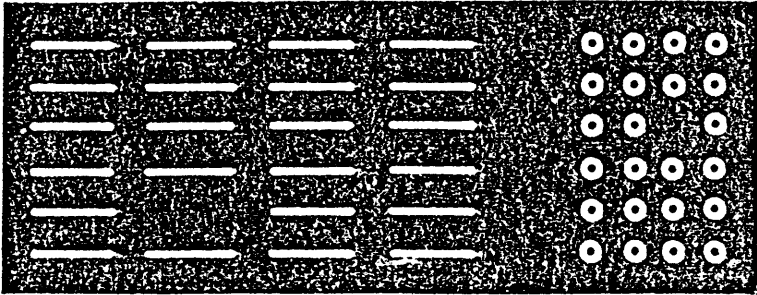

order out of chaos

the human need for meaning

We are constantly seeking to understand our environment. When presented with ambiguous environmental information, we naturally try to "order" it into a known form.

"The perception process always tries to extract meaning out of apparent chaos, documented by the Gestalt psychologists' principle of closure" (1)

In this manner we inevitably assign meanings to our stimuli in what has been described as the attributive aspect of perception. For example, if a pattern exists, we will immediately recognize the variant, and if a stimulus is mostly variant we will seek the pattern. This unconscious involuntary search for recognizable meaning in the environment is colored by our expectations and the manner in which the meaning affects us. The need for meaning is an active information seeking process.

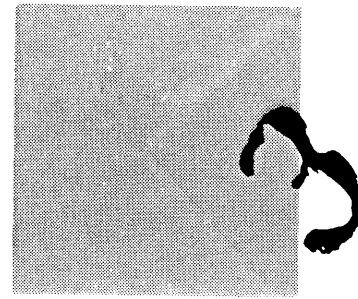

This pervasiveness of our meaning seeking renders everything we interact with potentially meaningful. Because of this, it is a priority to understand potential models of the communication of meaning, and employ them. For if we don't, we and our work will be interpreted anyway, perhaps to our chagrin!

definition of meaning

What is meaning? I understand meaning to ask and answer questions, an qualitative essence which is manifest in communication. Webster's New Collegiate Dictionary-1981 (certainly not the ultimate authority on this subject) defines meaning as: *"the thing one intends to convey..the thing that is conveyed esp. by language...something meant or intended..a significant quality..etc.*

This is close to the interpretation which I will use, that meaning is a kind of "information" which

relatively independent of qualifying constraints. It may be knowledge which is intellectually based, or an emotionally based response. It may be fixed or independent of time constraints or physical manifestations (objectified). Its significance as meaning, however, only becomes manifest in its communication. It may travel from inanimate objects to animate, between persons, or between a person and the self (thoughts have meaning).

the "interpretation filter"

The initial cloud of variations in understanding meanings may be attributed to the "interpretation filter" which is the flux between the values of the observer and the character of the object. It is generally recognized that the observer interprets the object with a set of personal and cultural values. However, relativity demands that we recognize that the object has a history as well, and (although it is not interpreting the observer) has many layers of information. This is most obvious in objects of human creation. A piece of contemporary art for example, may be the physical embodiment of an artists specific emotions and values; when this artwork is experienced by another person it is doubtful that the exact

experience of the artist will be communicated, and it is improbable that the observer would even know if it was or if that is even desirable. This is the potential for extreme transformations in meanings and forms of meanings within the interpretation filter. Similarly, information is inevitably understood within the observers frame of reference, and this "frame" may only show a segment of the original intention. These transformations form part of the reinterpretations of meanings.

interpretation filter

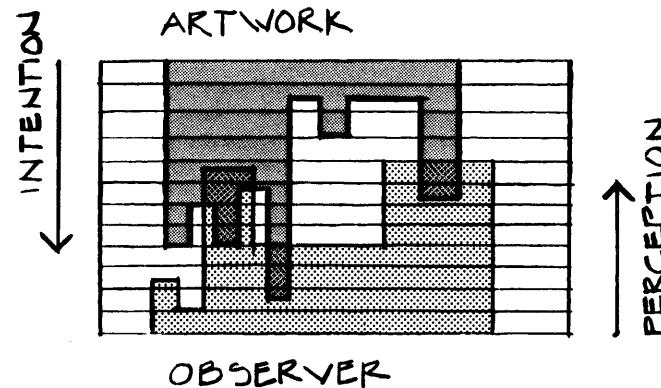

legibility

The alignment of our meaning seeking process and the intentions of the creation can be made more accurate with the assistance of cues in translation. Because we "read" meanings, we update our interpretations with additional information. Therefore, by providing increasing the number of cues as to the meaning, the possibility of accurate interpretation by increasing numbers of people is possible. Within limits, redundancy increases legibility. Taken to an extreme, this can lead to a shallow, self-evident statement. The reverse is more dramatic; meanings which are so obscure as to be illegible often risk being irrelevant to the intended audience.

notes

1) Lam, William MC Perception and Lighting as Formgivers for Architecture McGraw Hill, 1980 pg. 41

"No one knew exactly when she had begun to lose her sight. Even in her later years, when she could no longer get out of bed, it seemed that she was simply defeated by decrepitude, but no one discovered that she was blind... She did not tell anyone about it because it would have been a public recognition of her uselessness. She concentrated on a silent schooling in the distances of things and peoples voices.. Later on she was to discover the unforeseen help of odors...She knew with so much certainty the location of everything that she herself forgot that she was blind at times..."

Sometimes unforeseen accidents would happen. One afternoon when Amaranta was embroidering on the porch with the begonias, Ursula bumped into her.

"For heaven's sake" Amaranta protested, "Watch where you are going."

"It's your fault," Ursula said. "You're not sitting where you're supposed to".

She was sure of it. But that day she began to realize something that no one had noticed and it was that with the passing of the year the sun imperceptibly changed position and those who sat on the porch had to change their position little by little without being aware of it. From then on Ursula had only to remember the date in order to know exactly where Amaranta was sitting." (1)

levels of meaning

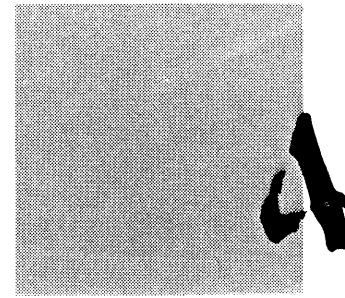

"Meaning" as transfer of information necessitates the encoding and reading of the concept from the physical material. As the relationship between object and concept becomes more abstract, more "cultural knowledge" is necessary to extract the intended meaning. Therefore, the hierarchy of levels of meaning proposed by Gibson becomes a valuable method of organizing phenomena. (2)

Gibson proposes three levels: concrete meaning, activity-oriented meanings and symbolic meanings. In this organization symbolic meanings are considered "higher level" meanings, as fewer people share this meaning.

Note that these are only categories for organizing our inquiry, and actual phenomena can happily coexist within several different categories simultaneously. The boundaries are further blurred by the crossover influence of categories (The Habitat/Habitus quandary). However we will consider them as distinct categories to better understand their properties.

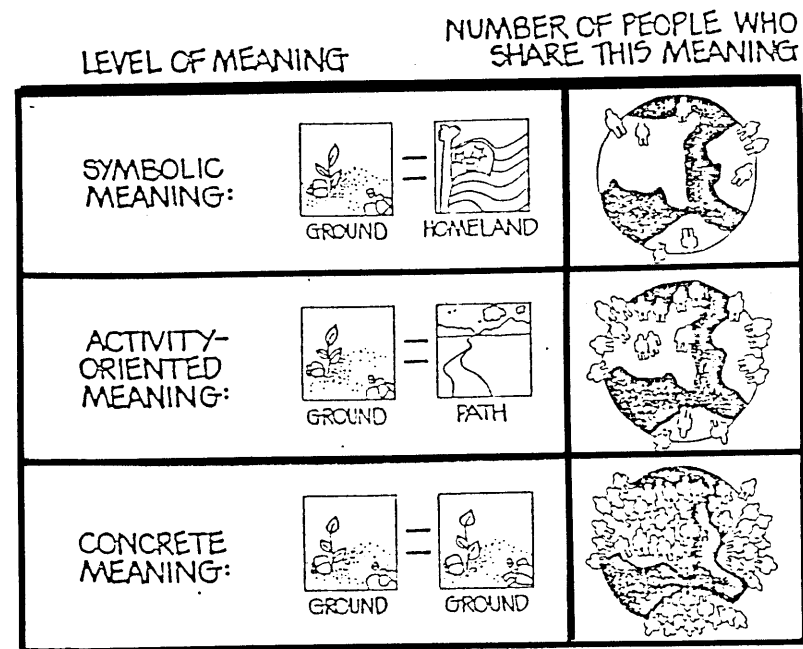

concrete meaning

Absolute congruence between object and meaning is designated here as "concrete meaning". In such instances wood means wood, and ground means ground. This degree of understanding is almost universal, however it is necessarily very limited in the range of information value an object may contain. We will not concern ourselves with this further.

activity oriented meanings

This is the first level at which the designer can "encode" meanings into the built environment. This information can be understood by most people, and is of significant interest to us here. Activity oriented meanings are dependent on our interaction with the environment to be legible. This is primary. Therefore, by walking on the earth we can understand path, by seeing a horizon we can understand up and down. Activity oriented meanings are based in our perceptual abilities and needs as biological beings. Based in our perceptual abilities, we receive activity oriented meanings through our senses, which makes this information necessarily subjective.

Activity oriented meanings do not require a socio/cultural context to be understood, and are essentially non-figurative, without external references. This does not mean the socio/cultural context does not influence the meaning, only that it is secondary to our initial primary perceptual understanding. This is a debatable concept. While this position is advocated by the likes of T.S.Eliot, Heidegger and Norberg-Shultz, many philosophers will deny the existence of a non-symbolic, culture-free meaning. For those who find this idea unpalatable, I suggest considering activity oriented meanings part of the "unlearned human culture."

perception

We perceive the environment through our senses. As biological beings we have dynamic perception. This quality is imparted to the object, creating a highly relativistic form of interaction, which is dependent on the whole for coherence.

"The plastic image has all the characteristics of a living organism. It exists through forces of interaction which are active in their respective fields, and are conditioned by those fields. It has an organic, spatial unity; that is it is a whole, the behavior of which is not determined by that of its individual components, but where the parts are themselves determined by the intrinsic nature of the whole." (3)

Our sensory perceptions are usually considered to be sight, smell, taste, touch, and sound. Recently, this has been revised (by Gibson et al) to be based on the type of environmental information we receive. This type of grouping results in the categories of visual, auditory, taste/smell, haptic, and basic-orienting systems. The haptic system may be defined as the sense of touch reconsidered to include the entire body rather than just the hands. To sense haptically is to experience objects in the environment by physical contact. The haptic system incorporates all those sensations (pressure, warmth, cold, pain and kinesthetics) which previously divided up the sense of touch, and thus includes all those aspects of sensual detection which involve physical contact both inside and outside the body.

The basic orienting system is that which is most commonly upset on the rides at the county fair.

"Basic orienting refers to our postural sense of up and down which, because of its dependence on gravity, establishes our knowledge of the ground plane. A consequence of this postural orientation is our need to symmetrize frontally the stimulus impinging on the senses of sight, sound, touch, and smell. For example, if a hunter senses danger he will turn his head and focus his eyes and ears symmetrically on the source in preparation for an attack or defense. This mobilized orientation involves a total body balance." (4)

We are constantly monitoring our environment for signs of change, all the senses take part in this "distant early warning system". This process is virtually impossible to stop.

"Consider 10 fans of an identical model, all grey except one which is painted red. The attention is drawn to the red one because of its color contrast with the others. If nine had been red, and one grey, the grey one would have attracted the visual attention because the very neutrality of its color made it a figure against a red background. Suddenly one fan starts to turn. Immediately the eye is drawn

to it, since its quality of movement distinguishes it from all the others. Then all the rest start, the eye wanders; all are now the same, in motion. There is no figure, no background, but if one slows down and stops, the eye will be drawn to it by its lack of motion, a new figure quality which distinguishes it from all others." (5)

These gifts of perception, and the manner in which we automatically employ them is not arbitrary, but rather has a sound basis in our biological needs as human beings. Lam continues this line of thought to compile the following list of biological needs for environmental information. (6)

Specific biological needs may be more or less relevant in a given context, and are difficult to discuss independent of their cultural implications. Certain aspects are obviously part of our psychological makeup as human beings, and in this sense provide what Norberg-Shultz describes as essential "existential footholds" on the world.

the example of sunlight

Walking down a hallway on a winter's day, a patch of sunlight on your shoulder is a welcome friend. It has a quality that is unmistakable--the same quantity of electric light would be unbearable. The sunlight has

BIOLOGICAL NEEDS FOR ENVIRONMENTAL INFORMATION.

- LOCATION, with regard to water, heat, food, sunlight, escape routes, destination, etc.
- TIME, and environmental conditions which relate to our innate biological clocks
- WEATHER, as it relates to the need for clothing, and heating or cooling, the need for shelter, opportunities to bask in the beneficial rays of the sun, etc.
- ENCLOSURE, the safety of the structure, the location and nature of environmental controls, protection from cold, heat, rain, etc.
- THE PRESENCE OF OTHER LIVING THINGS, plants, animals, and people
- TERRITORY, its boundaries and the means available within a given environment for the personalization of space
- OPPORTUNITIES FOR RELAXATION AND STIMULATION of the mind, body, and senses
- PLACES OF REFUGE, shelter in times of perceived danger

a wealth of information about your relationship to the environment, time of day, year, changing weather, etc. It affects your attitude towards orientation and identification with the environment.

In the last five years, a physiological connection between light and mood has been established. The S.A.D. syndrome (seasonally affective disorder) is described as a serious depression related to the lack of receiving enough sunlight as the proper times. This is most pronounced for people working indoors during the winter at high latitudes. The pineal gland produces a hormone called melatonin, which induces sleep and has been correlated with depression. It is normally produced when we are asleep and it is dark, but evidently a lack of light can stimulate production of melatonin as well. Psychiatrists presently treat S.A.D. patients with several hours of daily exposure to bright lights, the rough equivalent of 15 minutes of sunshine.

Thermal comfort in the physical environment is both consciously and unconsciously sought. The establishment of a comfort "zone" by Olgyay, subsequently refined by Giovanni, sets an empirical basis for this biological need. The influence of direct solar

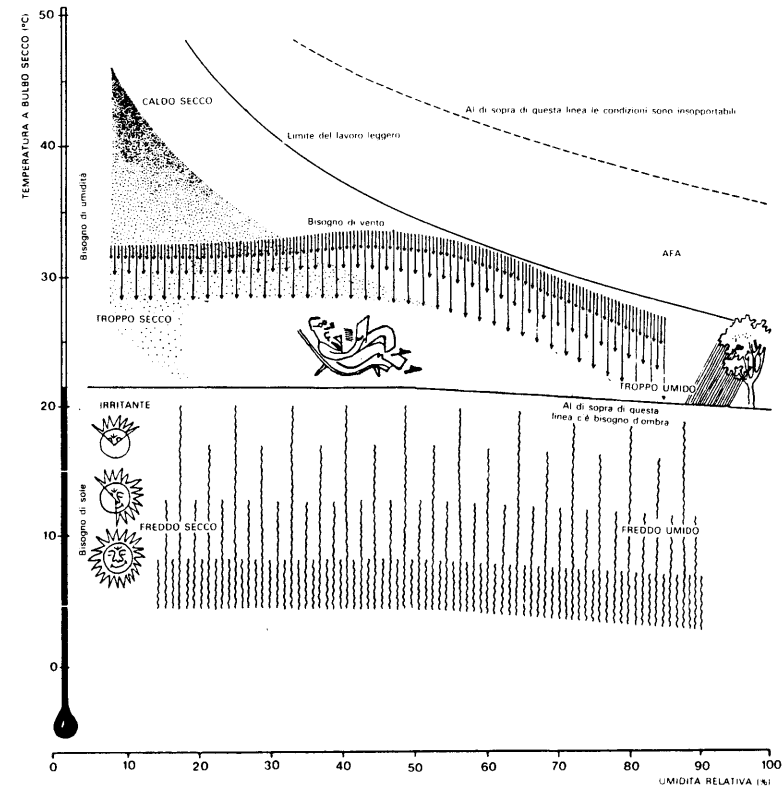

radiation (and surface re-radiation) on the mean radiant temperature (MRT) allows us to remain comfortable at a lower temperature, and when warm, become overheated sooner.

comfort and aesthetics

The concept of aesthetics originates from the idea of perception through the senses (hence anaesthetic, loss of senses). In this light, aspects of aesthetic principles may be more than a matter of taste, having a fundamental connection with the processes of perception and biological needs.

The relative nature of "Environmental Signal" to context and perceiver greatly influences its meaning. A clear contrast (or constancy) is immediately detected, but an ambiguous signal may create a sense of doubt or an uncomfortable distraction (tension) until the meaning is clear. Clarity in environmental signal can be comforting (enjoyed), and yet, an ambiguous signal may also rivet our attention.

"Our eyes relax and rejoice in sweeping over distant vistas, eyes may get used to a disordered vicinity, always close-up, but we keep suffering just the same, subconsciously, ... You will pay dearly for any such offense, though you may never clearly note what wasting leak your happiness has sprung." (7)

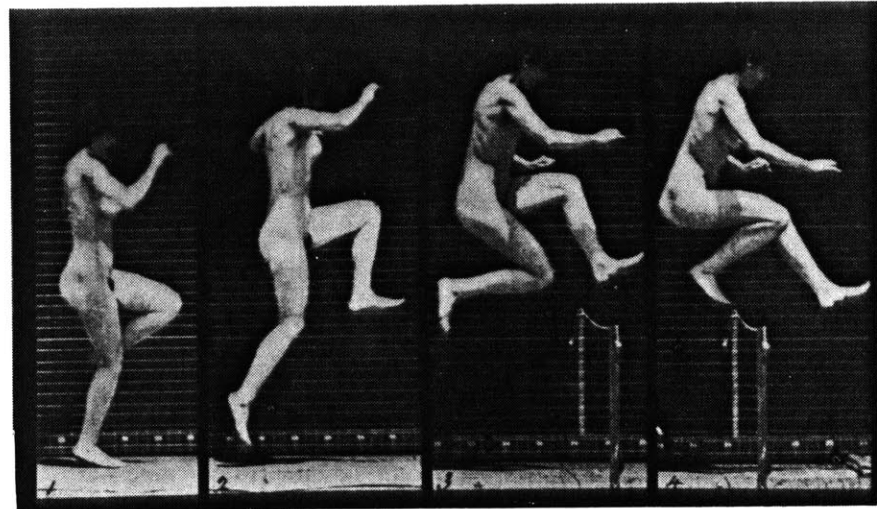

activity based user needs

Activity oriented meanings may take the form of cues as to how a space may be used. These "silent messages" can host a plethora of user needs by creating physical definitions and usable forms. Activity defined meanings are intrinsic to our relationship to the material form. When our relationship to the material form changes, the meaning is also altered.

Use forms are measured in relationship to our bodies, and perceptual abilities. A wall is understood as a barrier when it is difficult to look or climb over.

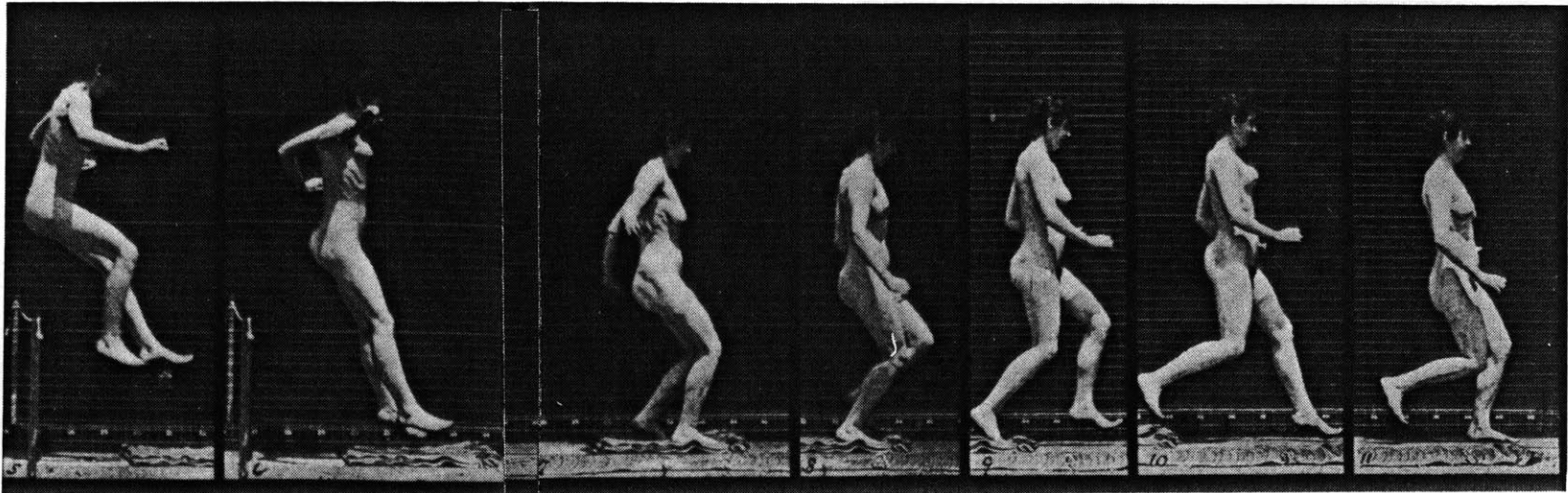

(Symbolically a barrier can be any definition, such as a line on the ground) Perhaps a good test of whether a definition is culturally or activity based is to consider if the definition's properties are recognizable by a dog. A dog would not recognize a symbolic boundary (unless taught) but will have no choice but to recognize a wall as an activity defined boundary. Activity based needs can be considered as horizontal and vertical definitions perceived in relationship to the human form.

vertical definitions

A shelter, a protected inhabitation, is primarily defined in the concept of being secure (from elements, or attack). In an isolated context, the covering of the sky with a roof is perhaps the foremost understood shelter. Underneath a roof a person is literally "inside", within a space defined by the edge of the roof.

As the roof is related to the sky, and protection from it, the floor is related to the earth, and has a similarly primary definition. We walk on the earth. In this instance, it is the definition of the floor



as other than ground which establishes the relationship. This delineation occurs sometimes symbolically as a change in materials or a mark on the ground, but more often it also contains a *displacement* of the earth below or above existing grade. This relationship of levels helps determine a person's response to the house.

Shelter as a private defensible space is most often *raised* from its surroundings (hence Italian hill towns). Builders innately understand this, and most "vernacular" buildings in the U.S. are raised a few steps from the ground. This symbolically defines an area of privacy as well as establishing an activity related meaning as protection (from high waters, etc).

The reverse of this is also relevant. Entering a house from the same level as the outdoors maintains a continuum of outdoors and indoors which can be either disconcerting or pleasurable.

definitions of horizontal perception

Horizontal definitions complete the opportunities for closure. Degrees of containment of a structure are directly related to its perceived isolation from the world. (Physically, visually, etc.) Similarly, horizontal definitions can create the perception of space, or of objects in space. An "object" could be considered isolated in space, and disconnected from the perceiver. "Space" is perceived from within, with horizontal (or vertical) definitions surrounding and containing the space. Christopher Alexander (et al) further elaborates and qualifies this, considering "positive space" that which has enough horizontal definition to feel contained, and "negative space" that which lacks sufficient definition in this respect. The manners in which this can happen are almost infinite. Perhaps the most absurd example of the extreme range of horizontal closure is found in Philip Johnson's glass house, in which the living area is perceptually transparent, without horizontal spatial definition, yet the bathroom is emphasized as a completely closed, internal, isolated object in space.

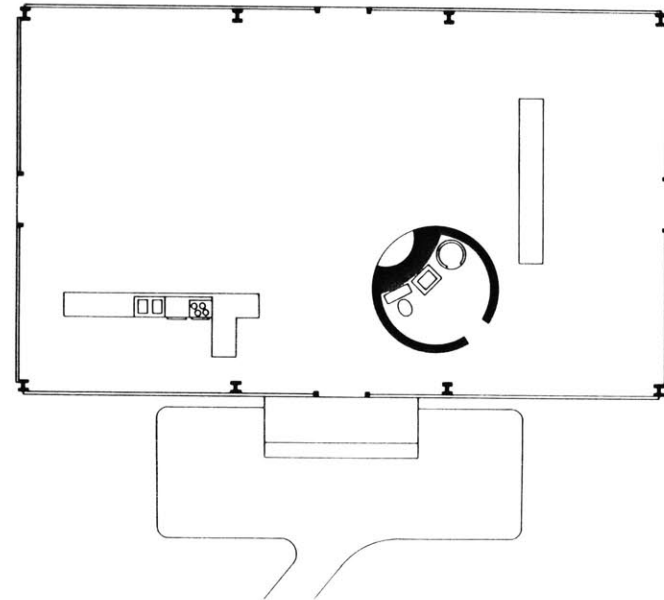

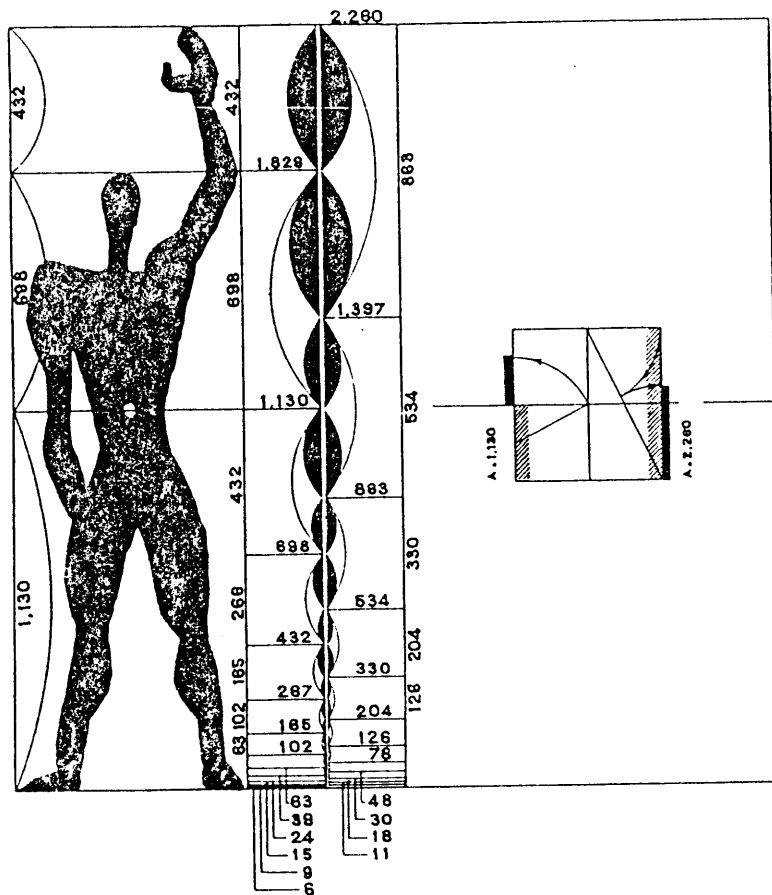

human size

Our activity-based environmental meanings are highly dependent on our physical size relationship. As our size or physical capabilities change, so does the meaning of the built environment we access. This can determine a given items use as a barrier, table or

step. Seats and steps are similar in their size ranges, so their functions often co-exist in an object. Useful size relationships are almost logarithmically related to our human dimensions; there are comparatively few sizes much larger or smaller that have an activity related meaning.

access

An activity oriented meaning that stems from our biological needs (as defined by Lam) is the quality of perceived access. A long view is often desirable as it is reassuring in allowing the maximum amount of visual information. An impending storm, or the arrival of a friend is not a surprise. Similar to the visual, physical access in the form of paths and negotiable routes are meaningful in providing for a primary activity oriented need.

behaviour and enabling bonds

This method of focusing on why places become personally meaningful is done by examining what places *allow* us to do: what perceptual, physical and psychological interactions and associations are possible.

In Judith Bowen's thesis "The House and its Bonding Channels" a careful analysis is constructed around structural, interpersonal and self-acknowledging "bonds" between a person and their environment. This approach illustrates many ways in which physical elements can embody meanings by providing access to human interactions and needs. (8)

Providing access to fulfilling these needs then allows for the possibility of a meaningful bond between a person and their environment.

The 19 "bonding channels" identified by Bowen span a range of physical, symbolic, and emotional needs spawned by our emotional makeup as human beings. For example, in the category of physical control it is recognized that control over the physical environment is a common desire. This can be expressed by a person being restricted (physically or cognitively) from asserting control, or by providing opportunities for a person to assert control, such as clear definition of ownership, or spatial definitions which offer opportunities for personal associations and identification.

BONDING CHANNELS

STRUCTURAL

- Movement
- Physical perceptual
- Physical control
- Ritual behaviour
- Semiological perceptual
- Semiological control

INTERPERSONAL

- Family interaction
- Family conflict avoidance
- Family structural
- Exhibition
- Contact
- Neighborhood interaction

SELF ACKNOWLEDGEING

- Sustenance
- Security
- Privacy
- Solitude
- Competence
- Self expression
- Associative

Within all these bonding channels are the understanding of how people interact with the environment. By providing access to a range of choices, the possibility for a meaningful bond are improved.

"And just as little is the bridge in the first place exclusively a symbol, in the sense that



it expresses something that strictly speaking does not belong to it." (9)

symbolic meanings

Symbolization allows meaning to be translated into another medium. "The purpose of symbolization is to free the meaning from the immediate situation, whereby it becomes a 'cultural object', which may form part of a more complex situation or be moved to another place." (10)

Symbolic meanings are an abstraction, a learned message associated with an object. As such they are socio-culturally based, even when highly personal. This is here described as a "higher level" meaning because symbols require a knowledge of their initial reference for accurate interpretation. Hence symbolic meanings are limited in clarity because of their basis in learned associations and references.

This associative basis for meaning carries several other properties. A symbol may evoke a wide range of associations, and therefore carry strong, complex feelings. Symbols are extremely subjective and hard to control. They are elusive. Conceptual associations are not intrinsically bound to an object and therefore the object's meaning may change, or the meaning may remain the same and the object carrying

the meaning may change. Symbolic meanings are of a transitional nature.

It has been said that over time applied associational meanings inevitably fall away from an object, and are replaced with new cultural interpretations. Symbolic meanings which do not disappear over time are tied to the object by means of self-reference. This creates a virtually intrinsic meaning contained within an object. It becomes autonomous of external reference. This "brand" of self-referential symbolism is often useful to assist in "decoding" an object until its meaning is revealed. A cultural object in such cases is capable of teaching the perceiver about its culture. Precedence obviously plays an important role in creating a viable past to emulate.

Symbols, self-referential or not, have the capacity to have extremely pervasive cultural meaning (and therefore influence). The concept of hearth is strongly identified with the center of the home. Long associated with food preparation, it is also the source of warmth, structural integrity, bonding with the earth, and familial gathering and love. Even when reduced to a two-dimensional illusion of hearth, many

of those associations remain (and a few may be added!). Because no activities need to be accommodated, meanings can be "compressed" into symbols, which can be easily attached or removed. Perhaps a common example is the non-functional shutters, which when added to a house symbolically create a "homey" context, and provide an avenue for personal expression and identification.

Incorporating an activity based reference to hearth (i.e., functional shutters or fireplace) reinforces the references that exist. The sheltering roof is a similarly strong symbol of home. Protection from the elements, identity as independent dwelling, and many other associated symbolic meanings all cause the pitched roof to be requisite to many person's definition of what makes a house a home.

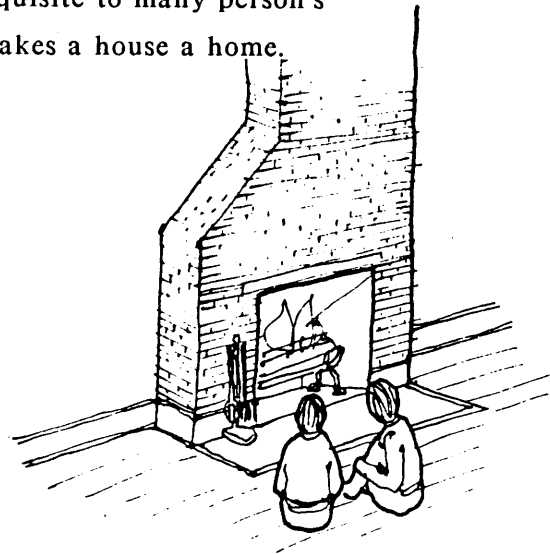

transitions in form and meaning

Symbols often evolve from use forms. Structural columns precede pilasters much as classicism preceded mannerism. The question remains; in this transition what characteristic architectural aspects are lost, and what are gained?

The degree to which character is lost may be related to the change in physical form or use from its origin. A pilaster cannot have the same spatial characteristics as a column, (although the symbolic meanings may be congruent). Similarly, a freestanding column not carrying a load is perceived differently from those in a colonnade.

The meaning as "column" may symbolically remain however disturbed the physical form, it is only the usefulness that may suffer. Almost any additional meanings can be associatively applied to the object "column", limited only by its nature as a cultural symbol. Mies glorified the steel I beam which in his eyes had the modern significance of the doric column. This transformation was lost on the populace at large, who had no idea what the architect meant, because it was a different cultural vocabulary.

symbolic biological connections

A symbol may attempt to "decode" itself and make its meaning more readily apparent by referencing primary information rather than self-referencing. Biological analogies such as symbolic "time" at Stonehenge are less mystifying because we intrinsically understand its reference. Biological symbolism is manifest in objects such as gravestones and cultivated fields. Often, simply the recognition that a human has made an intervention (identifying the presence of cultural information) will evoke a strong emotion, regardless of the degree to which it is understood.

notes

(1) Marquez, Gabriel Garcia One hundred years of Solitude.

(2) Becker, Franklin D., "Environmental Messages" in Housing Messages. Stroudsburg, PA: Dowden, Hutchinson, and Ross, 1977, pgs. 1-14

(3) Kepes, Gyorgy Language of Vision. Paul Theobald, 1944, pg.16

(4) Bloomer and Moore Body, Memory, and Architecture. Yale University Press, 1977, pg.34

(5) Lam, William M.C. Perception and Lighting as Formgivers for Architecture. McGraw Hill, 1977, pg.19



(6) Lam, William M.C. Perception and Lighting as Formgivers for Architecture. McGraw Hill, 1977, pg.21

(7) Neutra, Richard Mystery and Realities of the Site. Morgan & Morgan, 1951, pg.62

(8) Bowen, Judy The House. M.Arch Thesis, MIT, 1976

(9) Heidegger, Martin Basic Writings. Harper and Row, 1977, pg.331

(10) Norberg-Shultz, Christian Genius Loci: Towards a Phenomenology of Place. Rizzoli, 1980, pg. 17

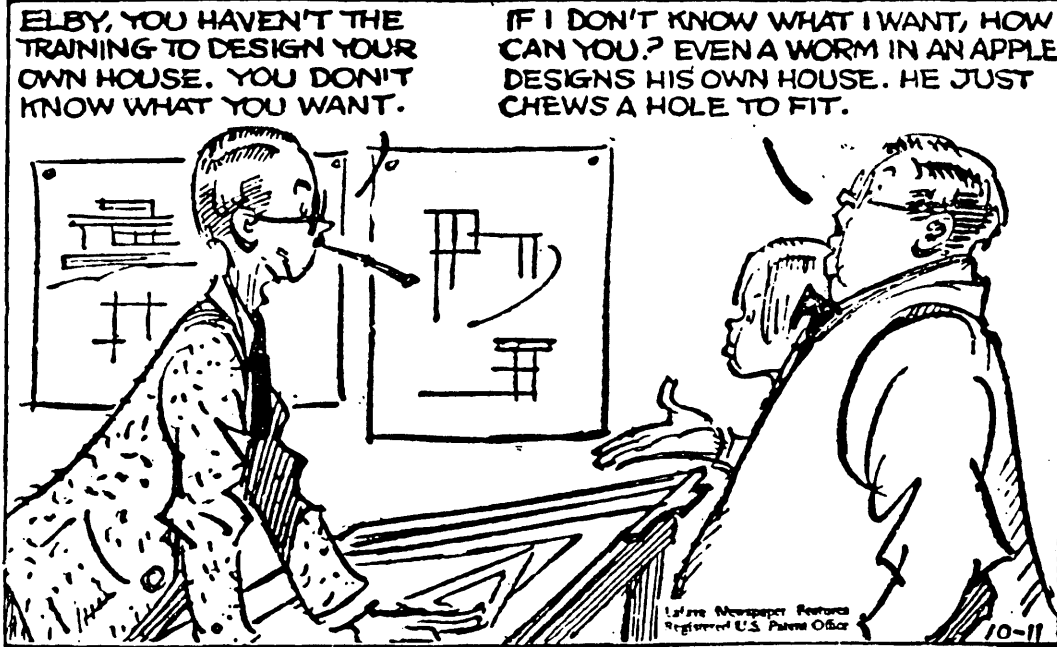

WHY THEY'D BUY

Motivating factor	Percent influenced
A more energy-efficient home	54%
Less yard maintenance	51
Fewer people at home	44
Smaller home	38
New design features	38
Tax advantages	31
New product features	30
Investment potential	23
Better neighborhood	19
Larger home	17
Change of scene	15
Security system	14
Tired of renting	10

building dwelling

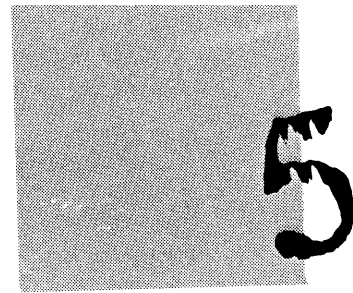

The built environment can be roughly divided into that which has been designed in a formal sense, and that which is quasi-vernacular (which constitutes the vast bulk of the built environment). These two groups, (builders and designers) bring quite different perceptions of what makes a house homelike to the world. At the risk of generalizing from the specific, this chapter details four case studies, two examples of builders houses and two architect designed houses to compare some constituent attitudes.

A builder will usually construct a building which is

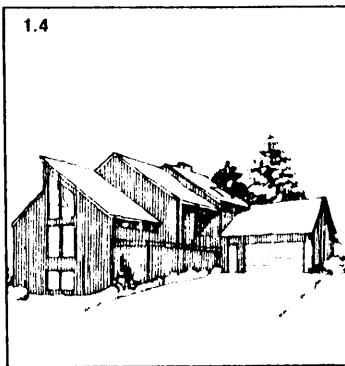

HOUSE STYLE

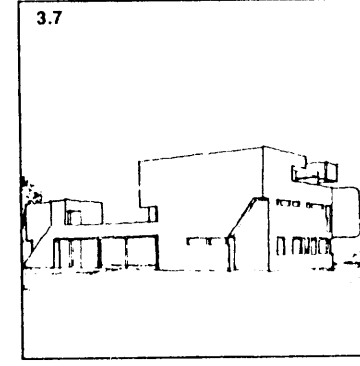
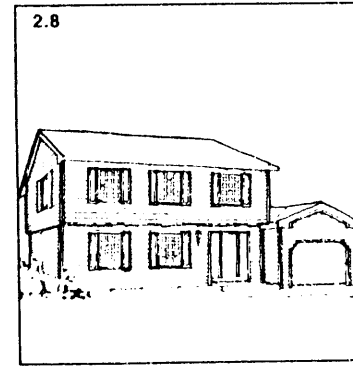
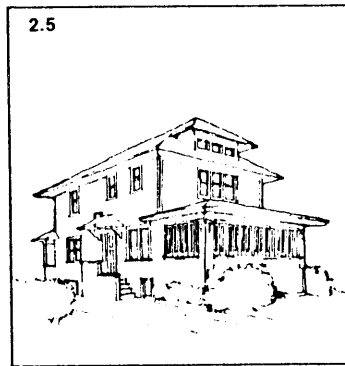

NOTE: THE LOWER THE NUMBER, THE GREATER THE PREFERENCE

functional from the standpoint of the common denominator; i.e. it will provide the necessary amenities required by the majority of the people, and thereby insure its marketability. A recent builders magazine survey outlined various criteria that builders should consider as marketable. (1) The symbolism which accompanies a "builders vernacular" house is that which contains a certain current cultural currency. These symbols may often have functional attributes as well, but their primary role is to fulfill the expected /desired house image. (2) In these instances the condensation of a desired value into an image allows it to be an applied

"symbol" of dwelling. Removal of such expected items will not change their functional aspect of the building, but it may remove some of the possibility for a cultural bond with the dwelling. Commonly applied symbols include conspicuously peaked roofs, non-functional window shutters, and entrance area embellishments. These are primary symbolic associations with dwelling in contemporary United States society.

Interestingly enough, when all the symbolic cues are stripped away, there is often a significant range of activity oriented definitions left that help constitute our sociologically "understood" definition of dwelling. Much of what is meaningful as dwelling is innate, built in a normally constructed building. As discussed in the last chapter, raising the entrance to a house a few steps is taken for granted, yet this small move provides an important activity defined zone of transition.

Providing this framework for dwelling, the builder depends on the occupant to inhabit, give identity, and thereby build/create a home. In Rapoport's words;

Most people move into ready-made environments and

fixed feature elements are rarely altered. They tend to form a given, although the particular choice made does already communicate, in and of itself...

Semifixed-feature elements range all the way from the arrangement and type of furniture, curtains, and other furnishings, plants, and "what-nots"...These can and do change fairly quickly and easily. Note that these become particularly important in environmental meaning in our own context, where they tend to communicate more than fixed-feature elements." (3)

This could also be summarized as "It takes a heap of livin' to make a house a home"

A designer differs in this approach to a project in that she often conceives of an idea with which to approach a problem and then uses whatever means are available (functional and symbolic) to achieve those ends. Designers will often use a design as an opportunity to educate a client as to their priorities in dwelling, and the resulting dwelling will refer to those ideas. The integration of the issues of domesticity and poetics are most successful when the client designer relationship is interactively constructive, thus insuring a congruence of intended

meanings. Otherwise the question may arise, "For who is this design meaningful?" The conflict may result in a dissatisfied client, or a designer disturbed by the transformation of his original intent. A classic example of the latter is LeCorbusier's housing at Pessac, where a dissatisfaction with the perceived "moorish" image of the houses led to a high degree of alteration and personalization by the occupants. Le Corbusier's spatial and sculptural messages were irrelevant to this audience. (4)

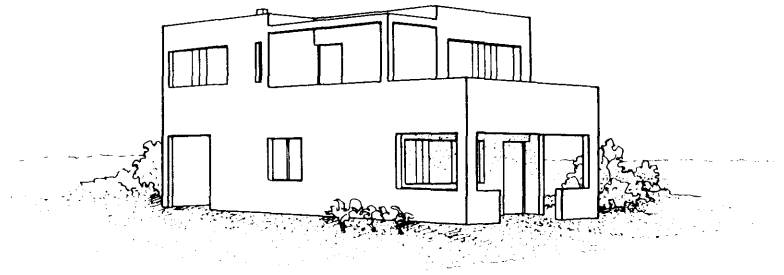

Some debate has occurred concerning the relationship of "designed" and "vernacular" ideas. Architects often decree that vernacular follows the designed typologies, and there are certainly enough greek revival, gothic revival, and "imitation usonian" ranch houses to point to. Even before Robert Venturi however, designers have "borrowed" from traditional forms and symbols, and the practice remains popular today. While this cross pollination can be beneficial, the contextual communication of these transferred meanings to the audience must be of paramount consideration, otherwise they will remain empty forms and symbols, misconstrued, and devoid of substance.



29. A house at Lège, by Le Corbusier (top, before; bottom, after)

Triple Deckers

Boston 1900



During the 1870's suburbs such as Allston, Jamaica Plain and Dorchester were annexed to Boston and the horse-drawn streetcar system was extended to serve them. This set the stage for tremendous economic and physical development in Boston. Given the opportunity to move from the crowded conditions of the old "walking" city, a rapidly growing middle class chose to move to the new "streetcar suburbs", where they were able to afford a free-standing one-, two-, or three-family wooden house with enough land to provide a sense of individuality. (5)

The triple-decker evolved as a unique and enormously popular housing style during the period of sustained building activity that began around 1890 and lasted into the 1920's. Initially there was some reluctance to the triple-decker, it was shunned as "worker housing" and triple-decker neighborhoods were considered undesirable. But the economy and benefits of this housing form was unparalleled, and by 1920, approximately 15,000 triple-deckers had been constructed in Boston, and the style had spread throughout New England. Free-standing houses with a

two- or three-bedroom apartment on each floor, triple-deckers provided more light, fresh air and suburban green space than the older brick row houses closer to the center of the city.

While the architectural and structural quality of Boston's late Victorian single- and two-family homes is widely appreciated, fewer people recognize that the triple decker is a Victorian housing type, built in the same tradition. Triple-deckers built between 1885 and 1900 reflected the popular Queen Anne style, with its fancy wood shingle patterns providing exterior decoration. Around 1900, the Colonial Revival style grew more popular and the triple-decker front porch became a showcase for elaborate variations on the columned Colonial entrance. While most triple-deckers have flat roofs, many have pitched roofs emulating their Victorian suburban neighbors.

Triple-deckers offered advantages to both owners and tenants. The income from two rental units made them financially attractive, especially to the family purchasing a first home. For the tenants, the fact that the owner lived on the premises usually provided assurance that the building would be maintained with pride and would remain a pleasant place to live.



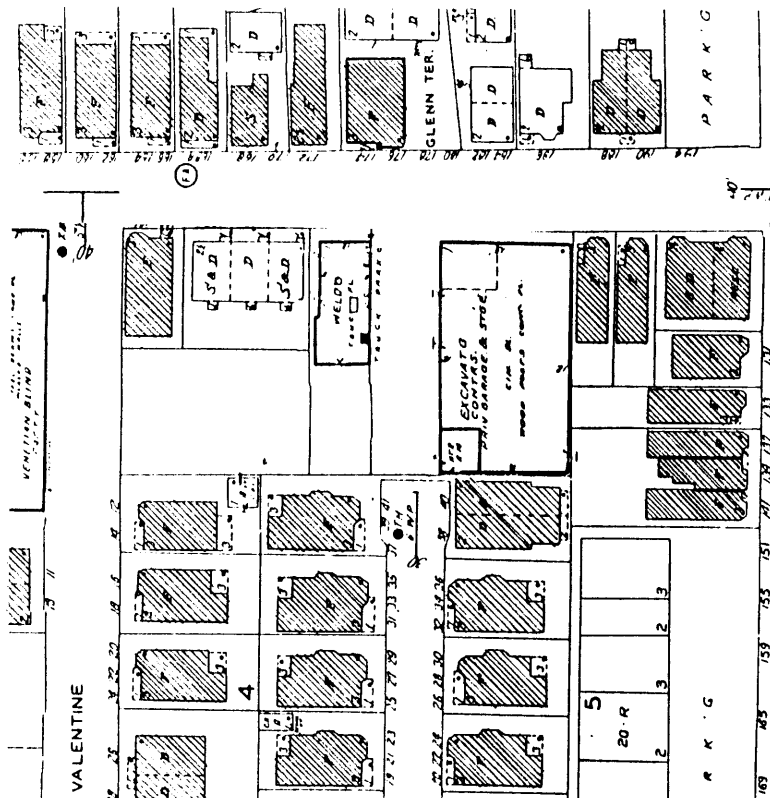

Triple-deckers were an outstanding success as a building type, combining economy with versatility and adaptability. Densities of 35 dwelling units per acre are not uncommon in triple-decker neighborhoods, reducing land costs per owner. A triple-decker could be two, three, six or more units; there are innumerable variations in size, style and quality, yet some important aspects remain constant, and greatly contribute to the triple-deckers continuous habitability.

Variety: Almost no two triple-deckers are exactly the same. Window moldings, floor plans, stained glass, porch details all serve to increase the individuality of these buildings. Therefore a neighborhood of triple-deckers is not a den of anonymous ubiquity.

Entrance: A clear front door (even if shared by several apartments), with a degree of private territory in front determined by the front porch, and normally raised 3-6 steps.

Double stair floorplan: A economic incentive to minimize street frontage evolved a long, narrow building with two internal means of egress. This adds flexibility to the building use and layout, as well as further "privatizes" the building, allowing one stair to be more formal and one more private.

Porches: A very important standard feature of triple-deckers is the inclusion of one or often two porches per living floor. These provide a semblance of outdoor living space for those on the upper floors, and allow for the inhabitants to be "connected" to the neighborhood street life.

Free Standing: As free-standing buildings of two to

eight units triple-deckers remain "house sized" buildings rather than "apartment" buildings. In addition to intimate scale and the ability to identify with buildings of this size, small free standing buildings allow for a large amount of windows on all four sides of the building, providing cross-ventilation and plenty of light.

Apartment size: 1000-1500 sq.ft. is a very comfortable size for a small family.

Bay windows: Bay windows are the most popular New England nook and cranny. By protruding out from a room they make a small area more spacious, while creating a cozy enclosing space from which to watch the world go by. Many bay windows include window seats. Light and air is increased by this fenestration configuration, and views are possible parallel to the building. Bay windows are New England's "people nests".

Adaptability: Constructed with bearing exterior walls, and normally a single interior bearing wall running the length of the structure, triple-deckers are easily modified for different living configurations. As such, they could almost be

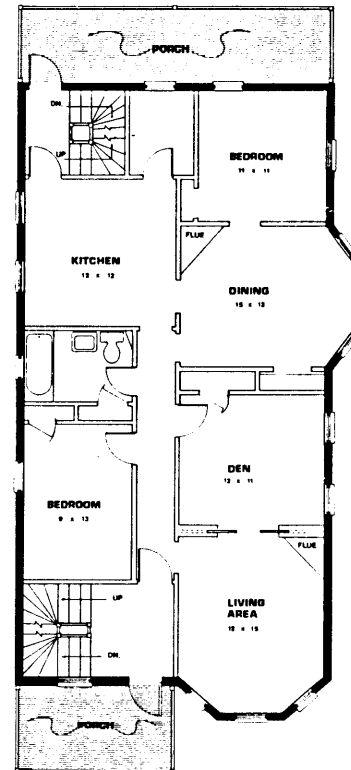

considered a venacular "support", allowing for user change and adaptation. (6)

These are but a few of the triple-deckers qualities which contribute to it's success. For better or worse, many factors (land costs, material costs, lack of craftsmen, etc.) have favored the construction of other housing types over the triple-decker since the 1930's. A tribute to their intrinsic value is their continuing desirability as housing in New England.

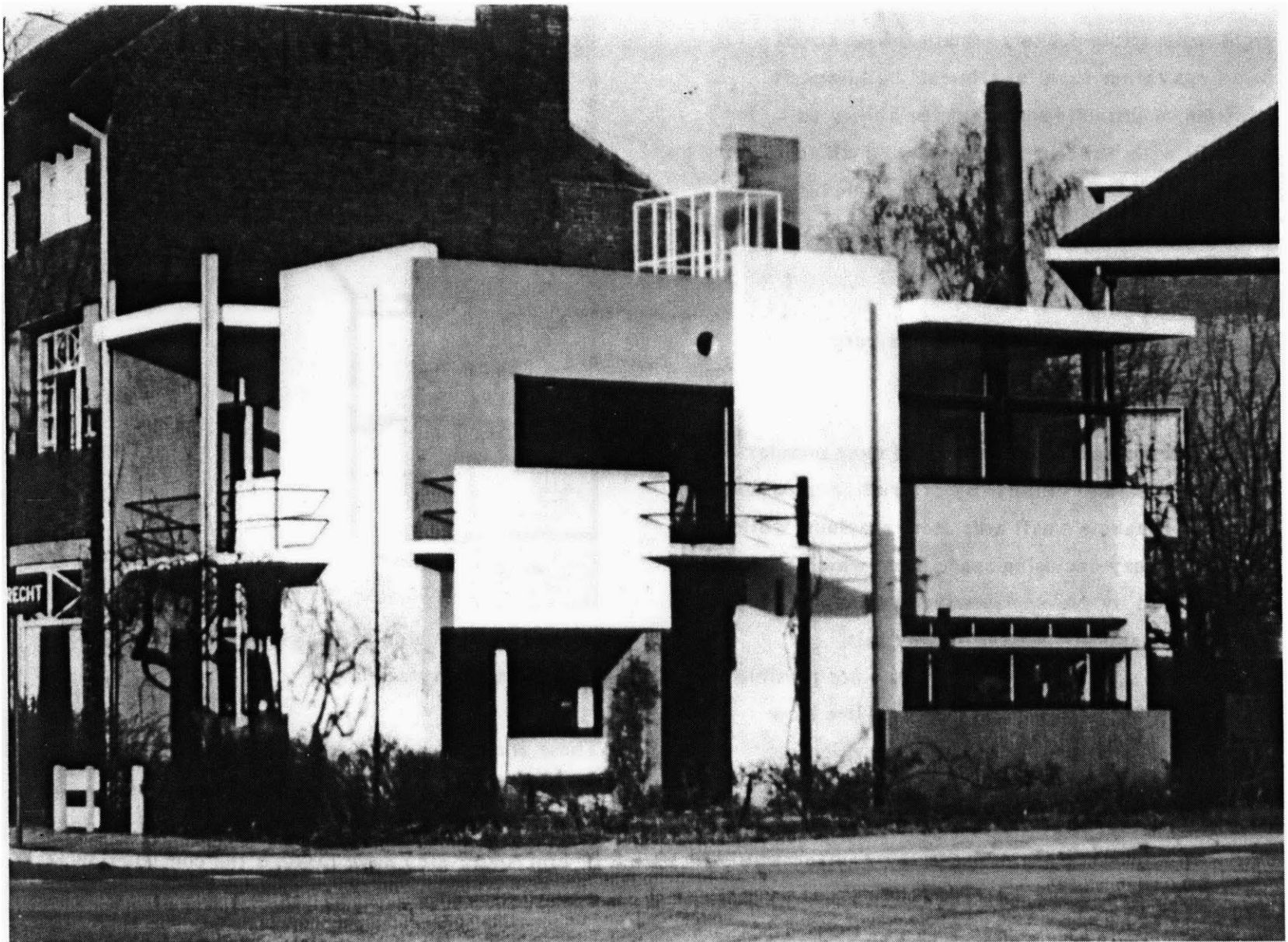

Rietveld/Schroder House

Utrecht-1924

Rietveld's first commission for a house ushered in a modern set of concerns to architectural design. Essentially concurrent with the emergence of the Bauhaus in Dessau (1924-5) and the De Stijl school, the Schroder house materialized ideas which had hitherto not been made explicit. Rietveld was curiously nondogmatic about design; perhaps his background as a craftsman allowed him to develop an honest attitude towards form making relatively unencumbered by rationalized academic aesthetics. The Red-Blue chair of 1918 exemplifies this approach; the process of building the chair influenced its final design:

"With this chair an attempt has been made to have every part simple and in its most elementary form in accordance with function and material, the form, thus, which is most capable of being harmonized with the whole". (7)

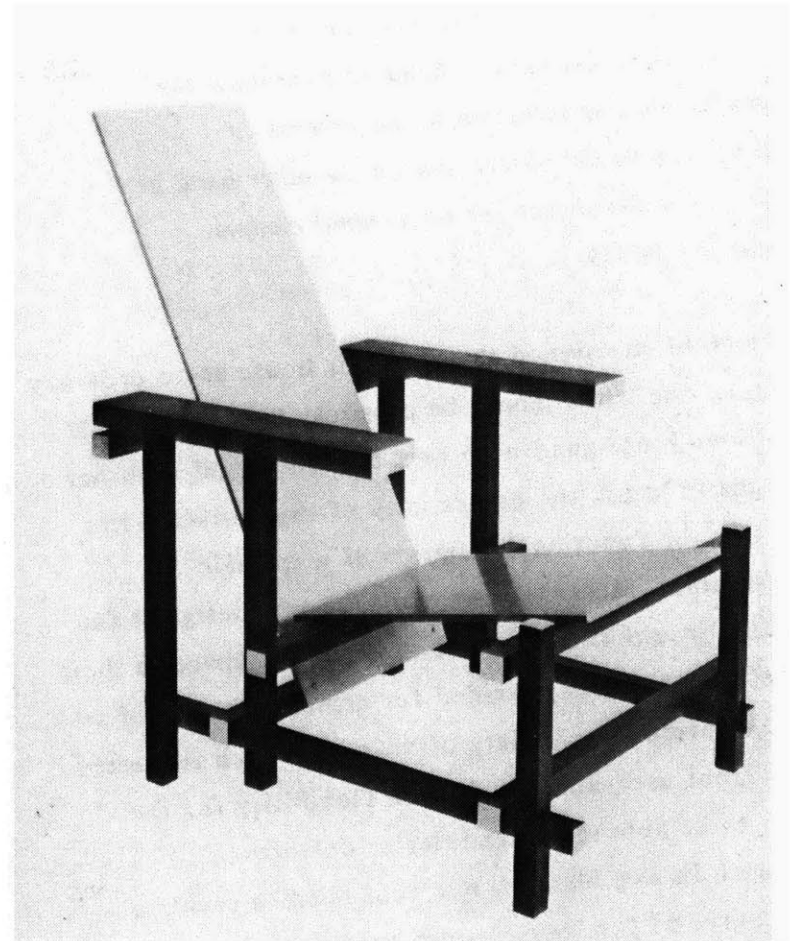

Although they may seem almost cliché now, in Rietveld's time these ideas made him a pioneer in understanding the inherent properties of forms. The schism between the artist-craftsman in Rietveld and the emerging architectural-industrial designer was also a source of freedom in his designs.

"Rietveld's feelings about his work were inconsistent. On the one hand he expressed the craftsman's satisfaction in the process of constructing the object; but on the other hand he designed the object for impersonal modern production". (8)

Rietveld envisioned the Schroder house as an ordinary home, one which could be possibly be prototypical. Although designed with Mrs. Schroder, and with her needs in mind, the domesticity of this building lies not in the functional program of a specific inhabitant, rather, a way of living was designed for which would allow anyone to tailor the space to their needs. The means provided for attaining this goal was the creation of a variety of volumes which suggested different uses, and building in flexibility for the user to be able to create interior definitions as desired. In this manner, Rietveld tried to create a "background for living rather than a straightjacket for living" (9)

Perhaps the upper floor of the Rietveld-Schroder house exemplifies this attitude towards space planning. It is essentially a single, large space which is organized around the central stairwell.

Partial definitions created by floor patterns, ceiling patterns, fenestration, furnishings and low walls can become completed, discrete spatial definitions with the use of a series of movable wall panels which can subdivide the space to varying degrees. The ground floor, although more conventional in definition and organization, does use glass transoms above eye level to visually connect the discrete rooms.

It is interesting to note that the programmatic/functional concerns of everyday living do not overwhelm this design, nor were they compromised. Rather, the space planning was an inherent aspect of this work, and programmatic uses contributed to aesthetic goals. The small sitting area by the front door is a case in point; the symbiotic integration of concerns compromised neither form, function or art.

In another situation, the architectural symbolism might have overwhelmed the domestic attributes of this dwelling. In this instance the close working participation of Mrs. Schroder with G. Rietveld insured congruence between architect and client in the form of ideas.

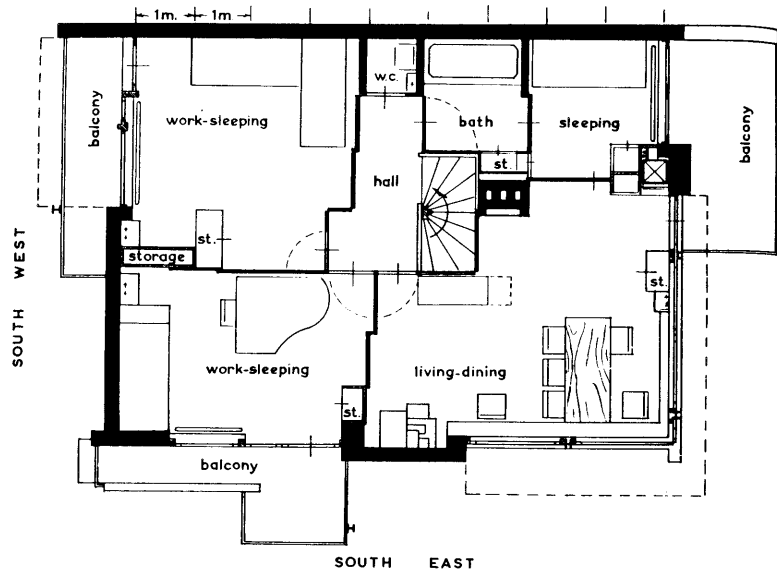

52. Schröder House, plan, upper floor, closed

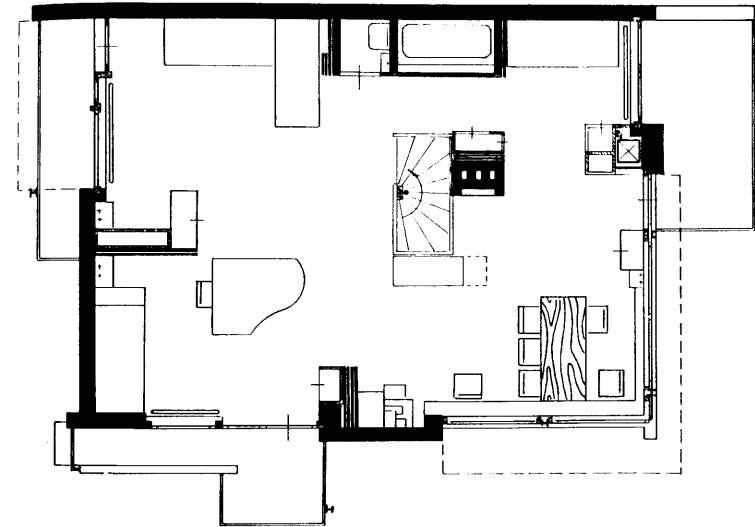

53. Schröder House, plan, upper floor, open

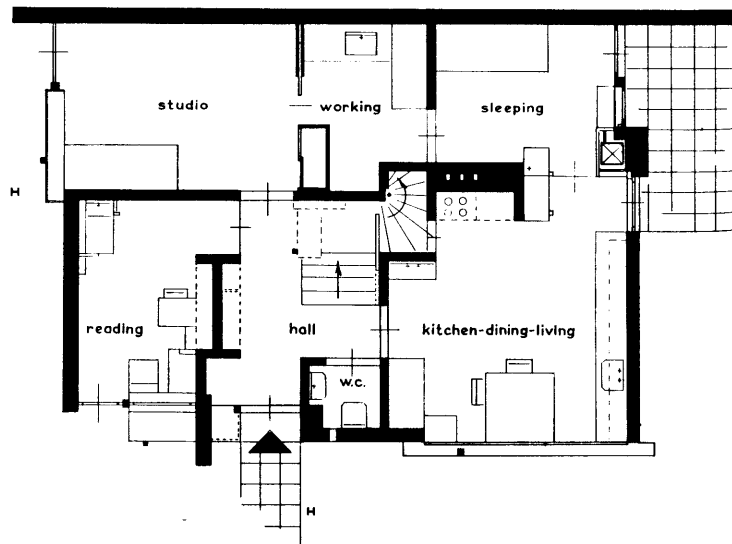

51. Schröder House, plan, ground floor, 1924 (cat. 26)

"The reality which architecture can create is space" (10)

To this ends the Rietveld -Schroder house is composed of many discrete parts which define its volume rather than its mass. Architecturally, this is manifested as a series of overlapping connections, displaced elements with space between them, and distinctions of color. The apparent discontinuities in the materials allow the space to remain continuous. This has the effect of lessening the apparent mass of the building as well as interlocking interior and exterior spaces.

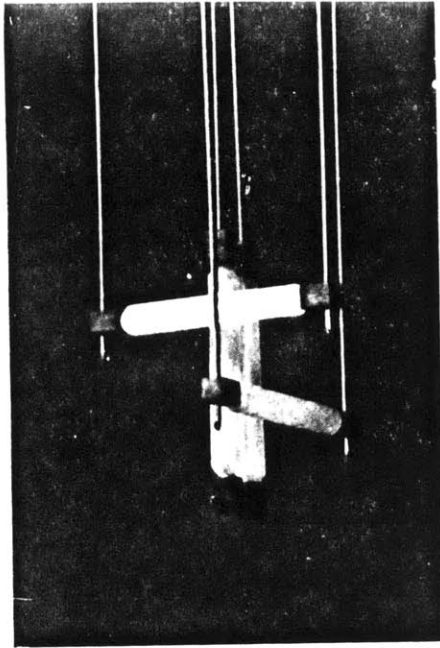

29. Hanging lamp, 1920 (cat. 14)

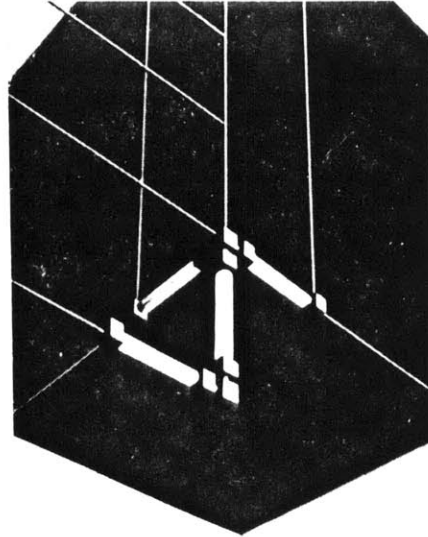

30. W. Gropius, Hanging lamp, designed in the Bauhaus, 1923

While the Bauhaus continued to explore the nature of materials and the possibility of form following function, Rietveld allowed no dictum to interfere with his spatial explorations. Gropius described the Rietveld-Schroder house as one of "Beton, Eisen, Glas" where in reality the house is of brick, wood frame, and plaster construction. Economy presided over honesty in expression of materials in this case. Rietveld's building came closer to Van Doesburg's De Stijl principals of 1924 entitled "Towards a plastic

architecture". In this manifesto, many elements intrinsic to modern architecture were first outlined. These included the destruction of symmetry, the inclusion of space and time as architectural elements, the anti-gravitational aspect and the formal (non-decorative) use of color. The Rietveld-Schroder house incorporates all this, and integrated the needs of domesticity as well.

Rietveld continued to explore issues of economy and domesticity in housing. In 1929 he envisioned the "core" house in which a central service core containing stairs, baths, utilities, etc, would be manufactured in a factory, shipped to a site, and the remainder of the dwelling built around the core as needed and as could be afforded. This idea is not dissimilar from the current practice of constructing partially completed building "supports" which are then completed with the assistance of the occupants. The core house was unfortunately never fully tested. Throughout the rest of his career Rietveld created dozens of dwellings, encompassing everything from modern housing projects to quasi-venacular lakeside homes. In all his designs there remains an understanding of the space defined by solids, and the stage these spaces set for living.

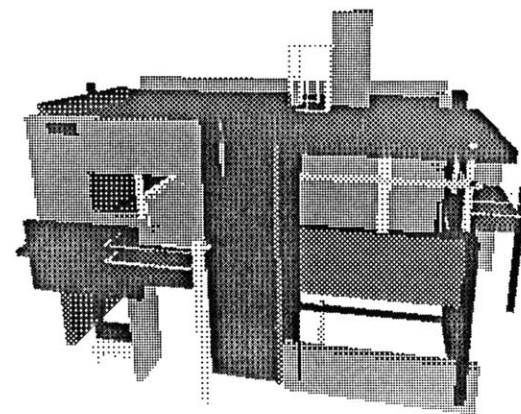
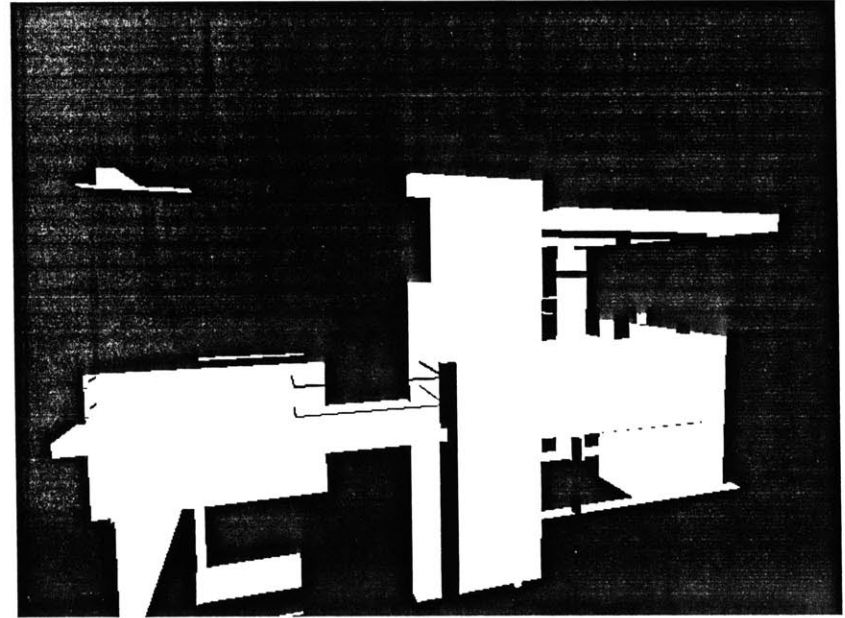

computer graphics courtesy miguel rueno

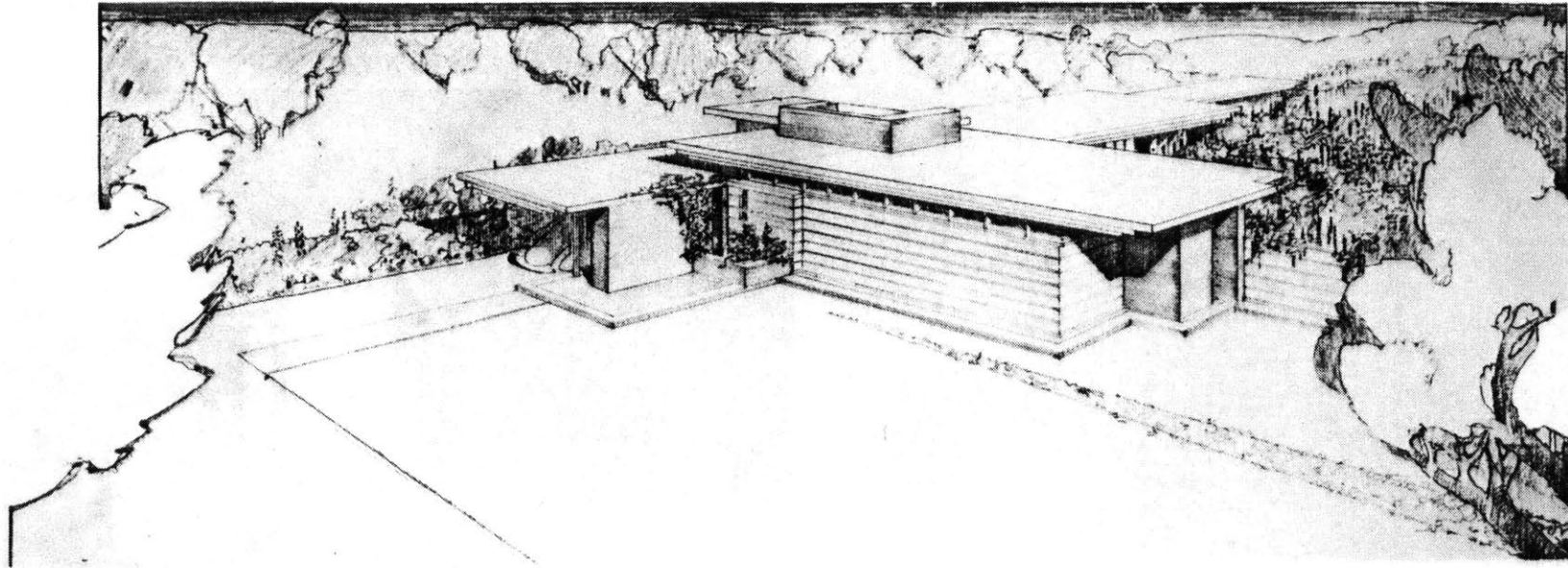

Frank Lloyd Wright's Usonian Houses
1936-1949+?

Usonia was Frank Lloyd Wright's method for introducing Organic architecture to the layperson. When the master architect of custom homes for wealthy clients turned his attention to "the problem of the small house", economy dictated a new methodology. Wright introduced a "kit of parts"; standard building components and details as well as a standardized concept of plan type, process of design, and construction. From these flowed hundreds of variations of the "Usonian" house.

The Usonian concept followed Wright's "Prairie Houses" and brought a new interpretation of the family social structure as reflected in the building plan. The overall size of the Usonian building plan tended to be small, with very small bedrooms, large built-in closets, and generally open planning to maximize the spaciousness of the house.

These houses were informal, unlike Wright's earlier majestic ships of the prairie. Lacking servants, (and servants quarters) these small houses were planned for easy maintenance. The kitchen was retrieved from the periphery of the plan and placed in the center of

the building, usually adjacent to the living room and partially open for interaction between the cook and guests. The dining room also disappeared as a discrete room, becoming instead a space within the livingroom.

This evolution of a "service core" has several implications. Often located at the intersection of the living and bedroom wings, it served a transitional function between public and private zones. As a "core" this area consolidated many services in an efficient, economical manner. The core of the Jacob's house, as described in Sergeant:

"The key to all this lay in the tightly designed "service core" of brickwork. The kitchen was efficiently laid out inside the service core like a ship's galley, with all the walls used for storage or appliances and the ceiling carried up to clerestory windows above the surrounding roofs. Odors were thus removed, while cooking activities went on out of sight but within conversing distance. The bathroom lay alongside, and a short flight of steps down led to a small cellar for heating, fuel and laundry. Attached to the exterior was Wright's invention, the carport." (11)

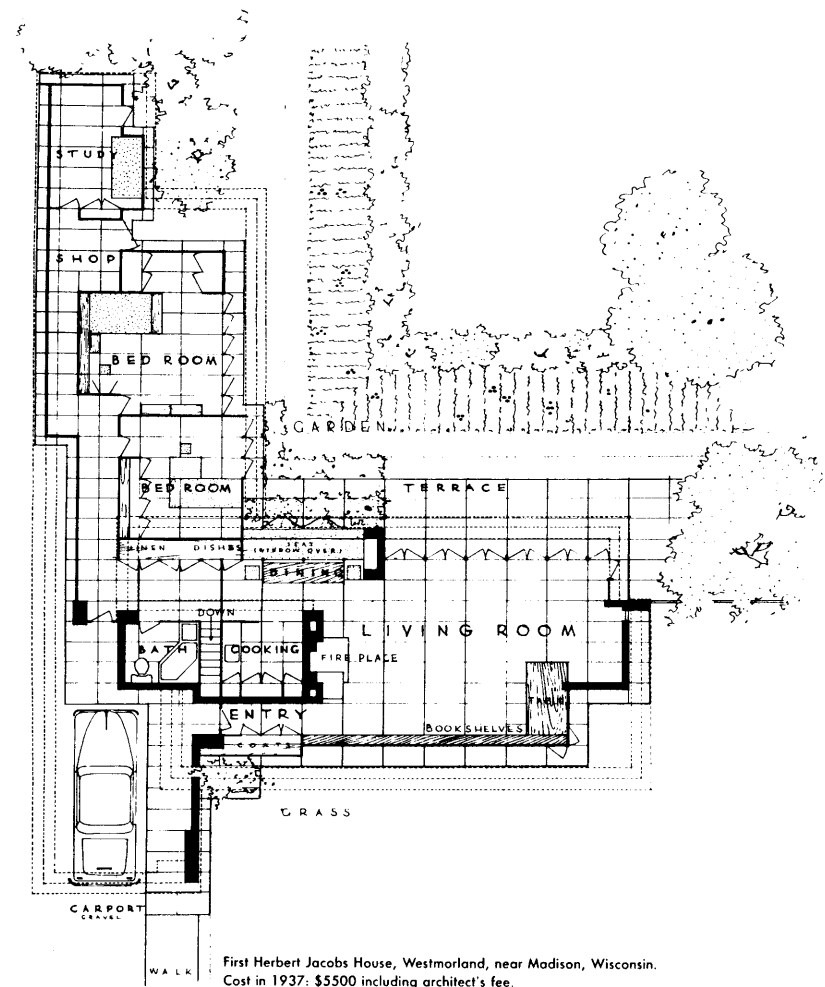

This central masonry core has an associative hearth-nature and often contained a fireplace on the livingroom side of the core. The adjacency of the kitchen to the hearth instilled a prominence and value to both the kitchen worker and work that was new to Wright's designs.

"She was now more hostess "officio", operating in gracious relationship to her own home, instead of being a kitchen mechanic behind closed doors" (12)

Usonian houses brought many other innovations; constructed with a clear system of masonry load bearing piers, the infill was free to be glazed or the famous wooden board and batten infill wall. Floors were often concrete mats, scribed with the regulating module of the building, and imbedded with hot water pipes for radiant floor heat. The buildings were most often single story "ranch" dwellings, without basements, and utilizing grade beams as foundations.

All of Frank Lloyd Wright's ideomatic architectural concerns continued to evolve and be manifested in the Usonian buildings, the horizontality, the careful site planning, the interlocking of building and

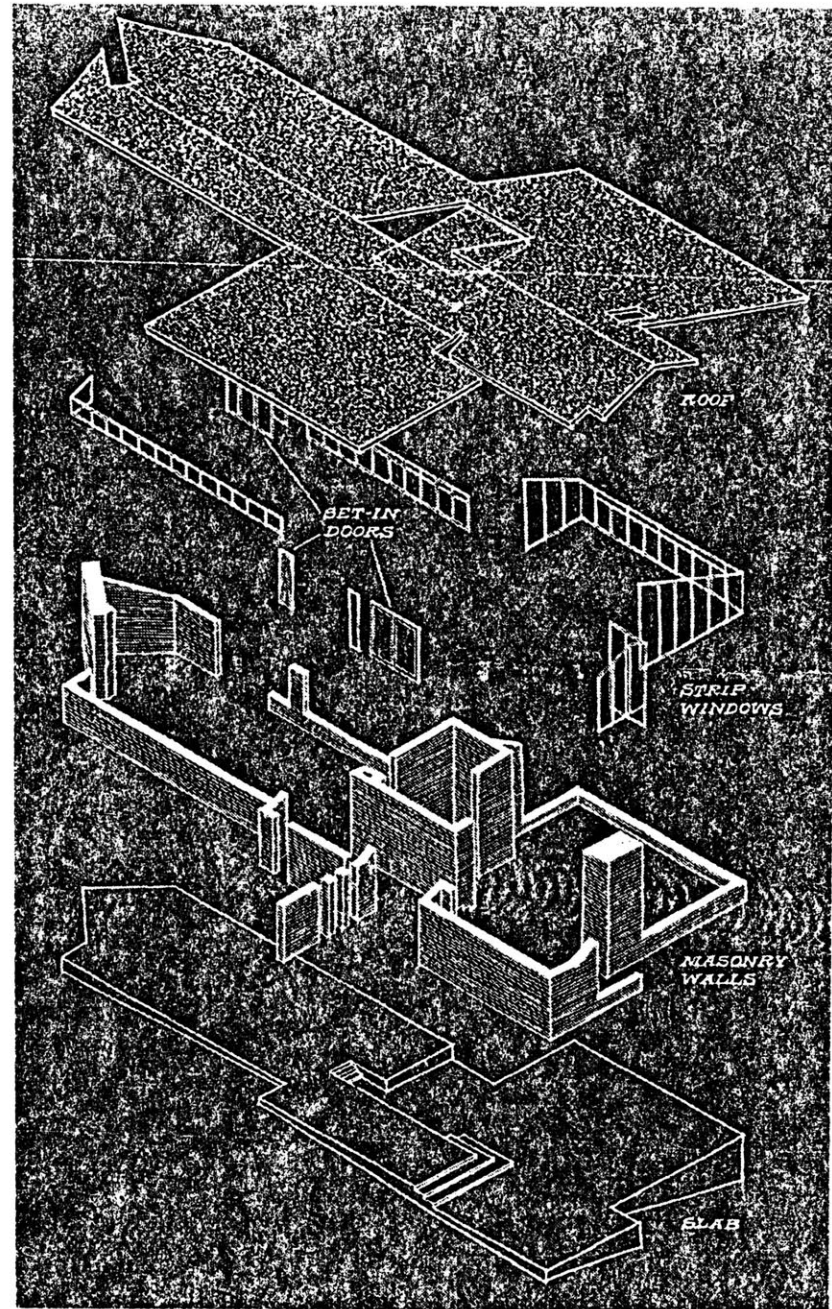

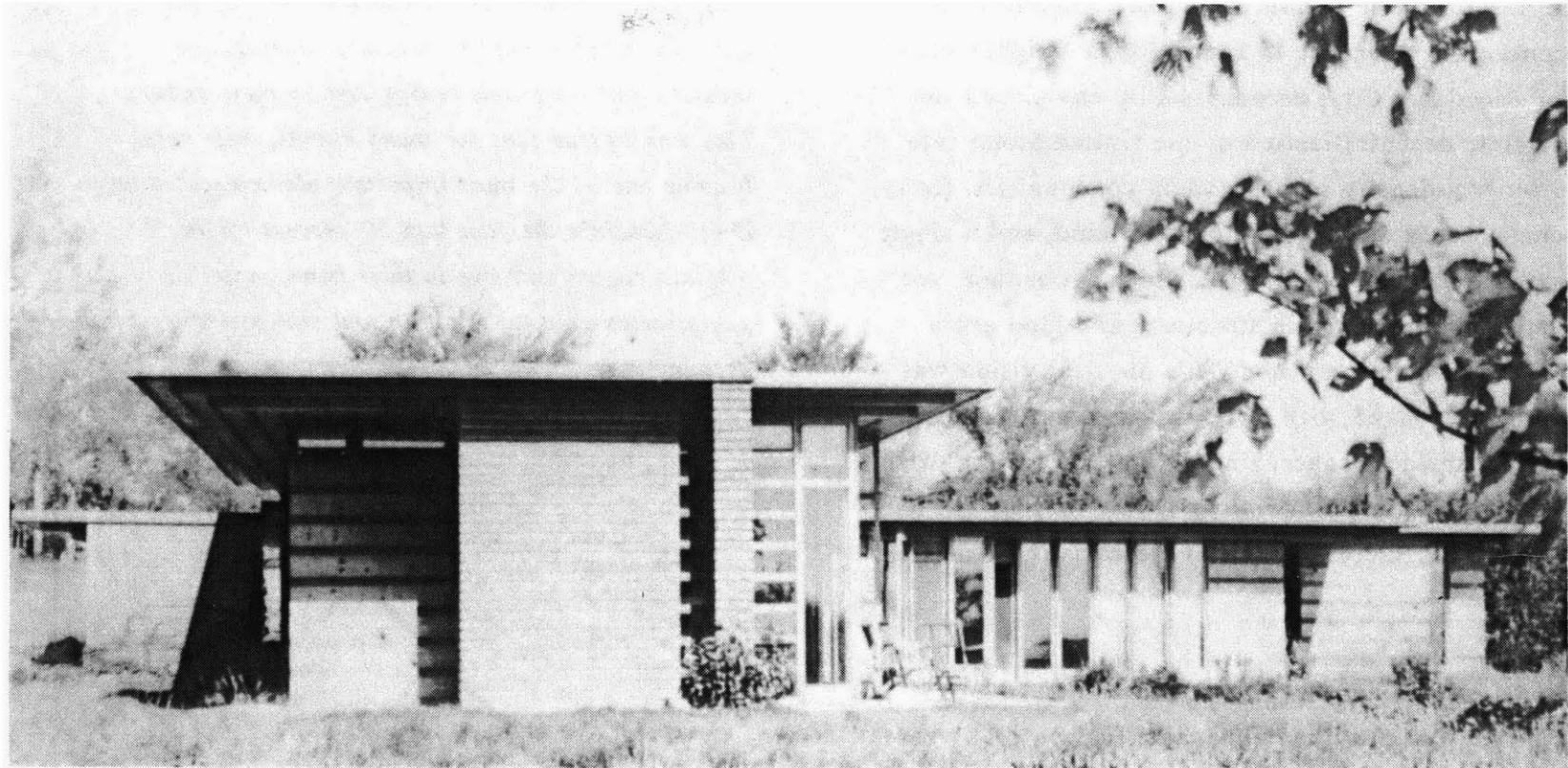

environment, the breaking of the box. The architectural grammar of these buildings is so apparent, and their form so additive, that it becomes easy to alter and add to these buildings without damaging their character. They willingly adapt to their occupants.

This is not to say that they are without fault. The strength of forms that Mr. Wright made was not always appreciated, and some persons prefer to live in a different manner than these dwellings allow. Among the most frequent complaints were the built-in furniture which did not allow for variations in arrangement, and caused numerous bruised ankles. However, most of Mr. Wright's clients knew what to expect and whether a Usonian dwelling was what they wanted.

No discussion of Usonia would be complete without mentioning their role in Frank Lloyd Wright's plan for Broadacre City. Broadacre City envisioned the complete decentralization of the United States into suburban density self-sufficient communities. Every person would own an acre or so of land, and a single family detached dwelling, of which a Usonian type would be ideal. Certain structures and land areas would be held in common. This physical vision was intimately linked with Wright's somewhat socialist - egalitarian ideas concerning democratic society. With such a global vision it was fortunate that Wright had created such successful initial pieces as the Usonian house.

Usonian dwellings were economical to build and maintain, but provided client satisfaction that went beyond that.

"The materials and spatial characteristics of the Usonians gave a sense of serenity, variety, and security that were well recognized by their owners. This was so true that for many clients, their home became one of the most important elements of their lives. Certainly the fact that 50 percent of the original clients still live in their homes after 35 years seems unusual if death and war are taken into account" (13)

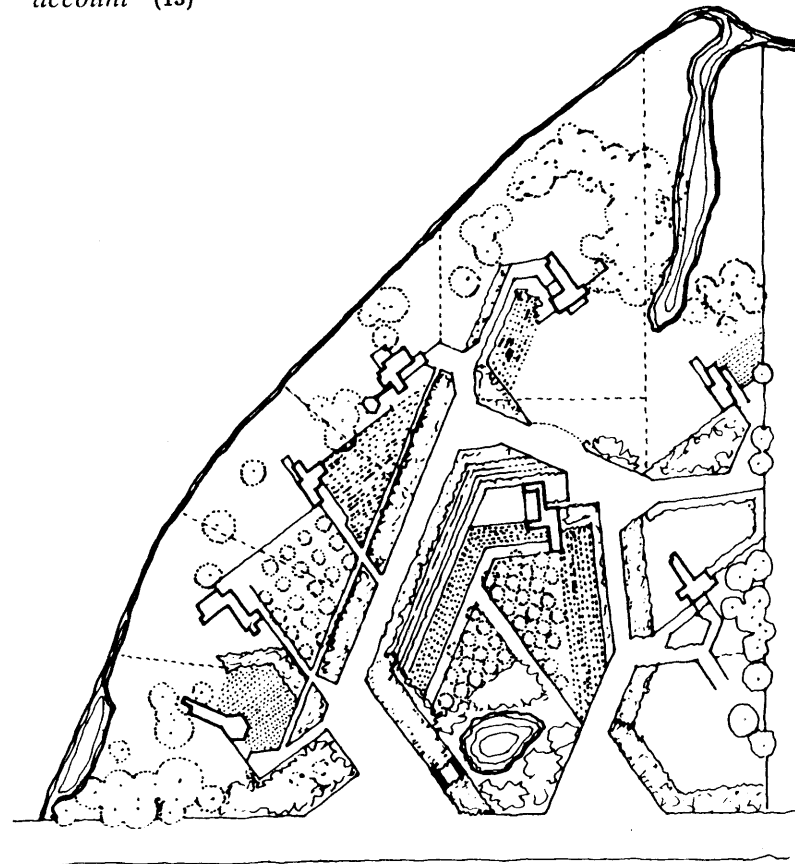

The Cape Cod Cottage

1710-????

Of the innumerable housing styles prevalent in the United States, the cape cod cottage is the most ubiquitous. It is found throughout the contiguous U.S. and north and south of the borders as well. Its continuing popularity after almost three hundred years is due in part to its adaptability and in part to its economy in meeting the manifold needs of dwelling. The cape cod design we are familiar with originated in New England in the beginning of the eighteenth century, during a boom in the east coast fishing industry. Early capes were built by these workers and fisherman and have been described as "land boats" because of their sturdy construction and environmentally adapted design. Some capes were actually built and then literally set afloat and towed to their final destination. (14)

These houses were characterized by a simple rectangular plan, a large central fireplace and chimney, a steeply pitched unbroken gable roof with little overhang, and virtually no decoration on the building. The small multipaned windows and doors were placed close under the eaves, although on the gable



ends the fenestration was often irregular and determined solely by the internal requirements of the plan. The facade proper was normally approximately eight feet high, allowing the whole house to sit very close to the ground. Capes generally face south, allowing the light to enter, and the north winds to sweep over them.

Early capes were built with pegged posts and beams making them extremely durable. The normal straight gable roof was sometimes replaced with a gently bowed roof, made by bending green timbers to create curved rafters. Ostensibly done to make the roof more resistant to compression, bowed roofs extolled the

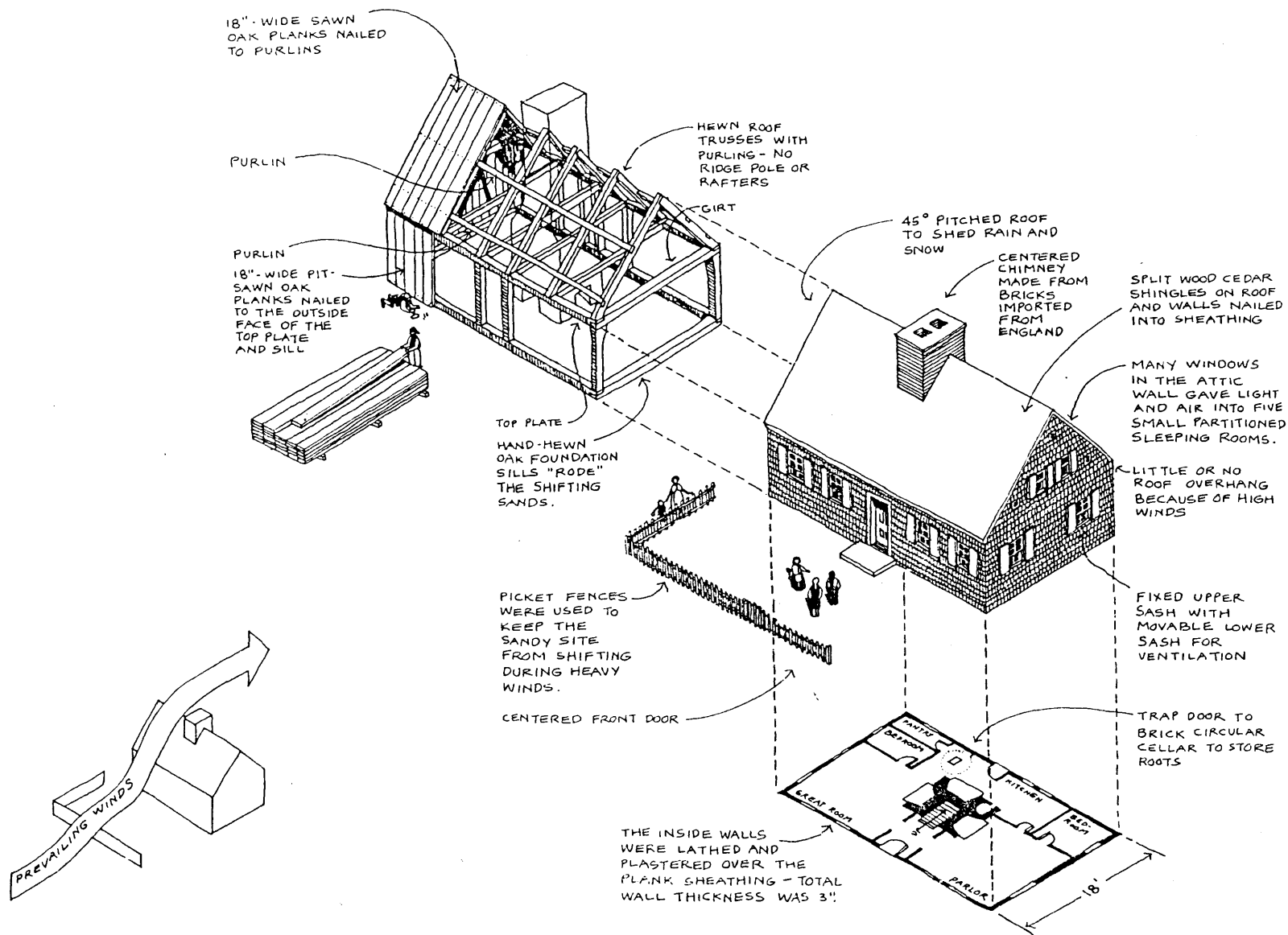

THE CAPE COD HOUSE WAS CONSTRUCTED AND PLACED ON THE SITE SO THAT PREVAILING WINDS WOULD NOT HARM IT.

1710 FULL CAPE COD HOUSE, MASSACHUSETTS

craftsmen's art and contributed to the cape's nautical allusions.

In the 1850's the immense popularity of victorian housing styles put the cape to rest for a while, but it reemerged in the wake of the great depression of the 1930's. The cape style answered the popular need for an easily built, inexpensive dwelling with the reassuring image of the single family home. No small amount of the rejuvenation of the cape style can be attributed to marketing. Architects such as Royal Barry Wills of Melrose, Massachusetts, designed capes almost exclusively, and magazines such as House Beautiful also contributed to the popularization of the cape. However it was the post World War II construction boom that contributed the most to the exploitation of the Cape style. (15)

The Cape is very easy to build and provides an ideal beginning for adaptation to most popular needs. The most common alterations are either gable or shed dormers, which greatly increase the habitability of the second floor. Lengthening the house, or adding wings for guests, garages, etc. is very common, as is architectural trim embellishment and ornamentation, such as shutters, quoins, porches and pilasters.

Aside from the pragmatic qualities of Capes, they have numerous aspects that have enormous emotional appeal. The dominant element of the cape is its gabled roof, forming a greater proportion of its visual presence than the vertical facade elements. This low, hunkering, sheltering roof embraces the occupant like a mothers arms, protecting from the elements and creating a "separateness" from the outside world. The dominance of this gable re-enforces the single family character of the cape (Capes make terrible rowhouses!) and increases the consumers sense of ownership.

Within the house the sense of the roof remains dominant, ceilings are generally seven foot high on the first floor and constricted on the second floor by the impinging gable. This creates a certain coziness, an intimacy that appeals to womblike, nesting instincts. This epitomizes the "insideness" of interior spaces.

The humble exterior is unassuming, and reflects a certain endearing unpretentiousness on the occupant. It is by no means lower or upper class, but rather states a satisfaction with the status quo. This can translate into a sense of belonging to a community

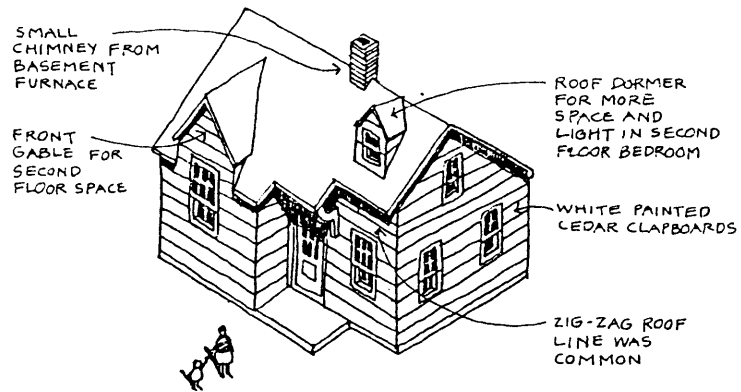

1945 POSTWAR CAPE COD

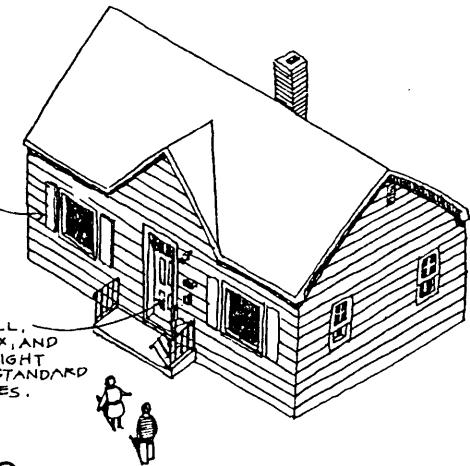

1950 MODERN CAPE COD

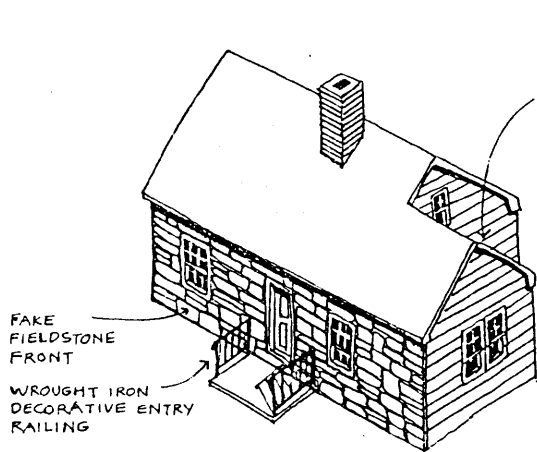

1955 CONTRACTOR'S DEVELOPMENT CAPE COD

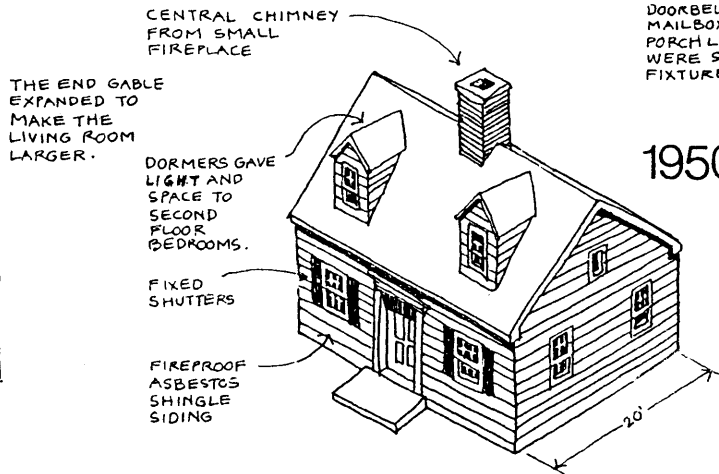

1960 BASIC "NEW" CAPE COD

created by living in a neighborhood of similar houses. Conversely, an outsider who dares to differ greatly in his dwelling style may bear the brunt of being ostracized.

The Cape Cod cottage is in many ways the germinal origin of a plethora of single family dwelling styles. In this light, the cape lies deep within each

victorian ranch and bungalow dwelling, and the discovery of this origin, makes us long for it again. Thus, encountering the germinal cape in the landscape, unencumbered by complexity, is in a very real sense a homecoming. Much as a Bach canon has origins which are then manipulated and transfigured, a complete resolution is only possible when the music returns "home" to its original phrase.

notes

- 1) Builders Magazine Housing Survey April 1984
- 2) Preferences in Dwelling Design The Minneapolis / Saint Paul Family Housing Program, 1985
- 3) Rappoport, Amos The Meaning of the Built Environment. Sage Publications, 1982, pg.89
- 4) Boudon, Philippe Lived-in Architecture. MIT Press, 1979, pg.71
- 5) Krim, Arthur J. Triple Deckers of Dorchester: An Architectural Historical Survey. Boston Redevelopment Authority, 1977
- 6) Habraken, Hamdi, Hellinghausen, Testa, Woods Infill Packages in Housing Development. unpublished
- 7) Rietveld De Stijl. 2:11 Sept. 1919

- 8) Brown, Theodore M. The Work of G.Rietveld, Architect. MIT Press, 1968, pg.22
- 9) Brown, Theodore M. The Work of G.Rietveld, Architect. MIT Press, 1968, pg.51
- 10) Rietveld INZICHT 1928 pgs. 89, 90
- 11) Sergeant, John Frank Lloyd Wright's Usonian Houses. Whitney, 1976, pg.19
- 12) Wright, Frank Lloyd The Natural House. Horizon Press, 1954, pg.116
- 13) Sergeant, John Frank Lloyd Wright's Usonian Houses. Whitney, 1976, pg.27
- 14) Walker, Lester American Shelter. Overlook Press, 1981, pgs.89,90
- 15) Schuler, Stanley The Cape Cod House. Schiffer Publishing Company LTD, 1982

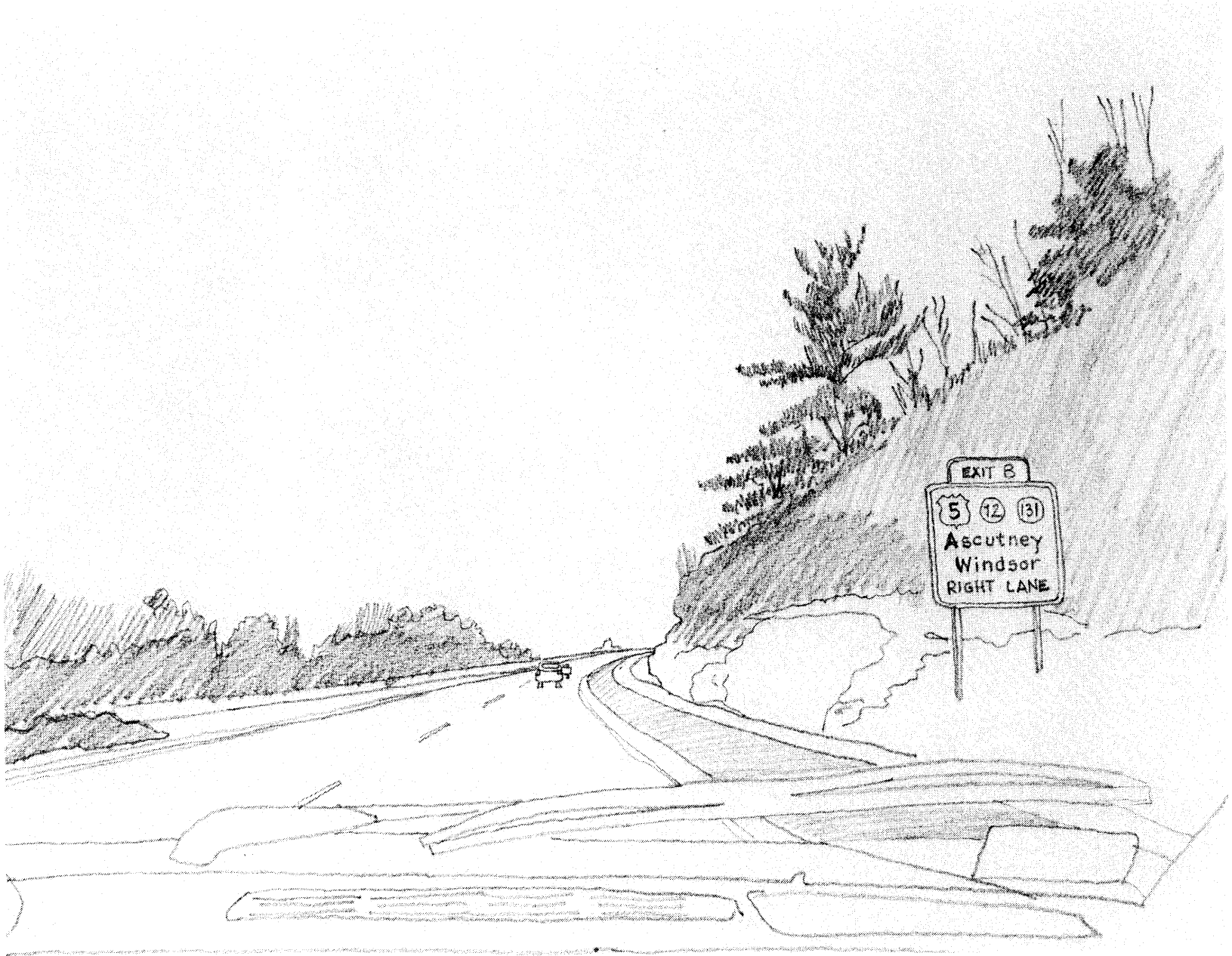

transformation

Architectural design allows for the attempt to graphically illustrate built manifestations of values and meaning. This specific design exercise offers a direct comparison between dwelling as defined by a builder and the same building transformed and redefined to exemplify my understanding of dwelling as an architecture student.

gathering the site

Ludlow, Vermont is a small town located in a valley along the Black river. Quiet for most of the year, Ludlow perks up when the snow covers the slopes of Mt. Okemo, attracting the annual influx of "flatlanders" eager to break a leg. The rather severe climate and the accompanying ski tourist dollars make Ludlow somewhat more affluent and less traditional than adjacent Vermont towns.

From the south bank of the Black river East hill rises 500 feet above the town. "The Hill" has had folks living on it as long as Vermont has had cows,

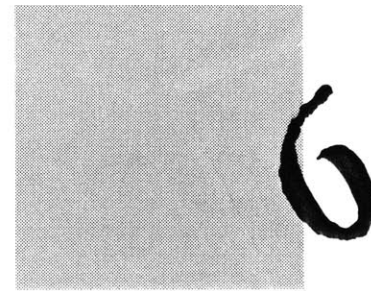

QUADRANGLE LOCATION

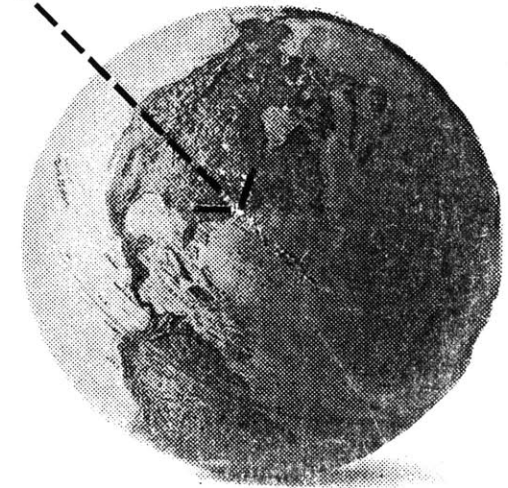

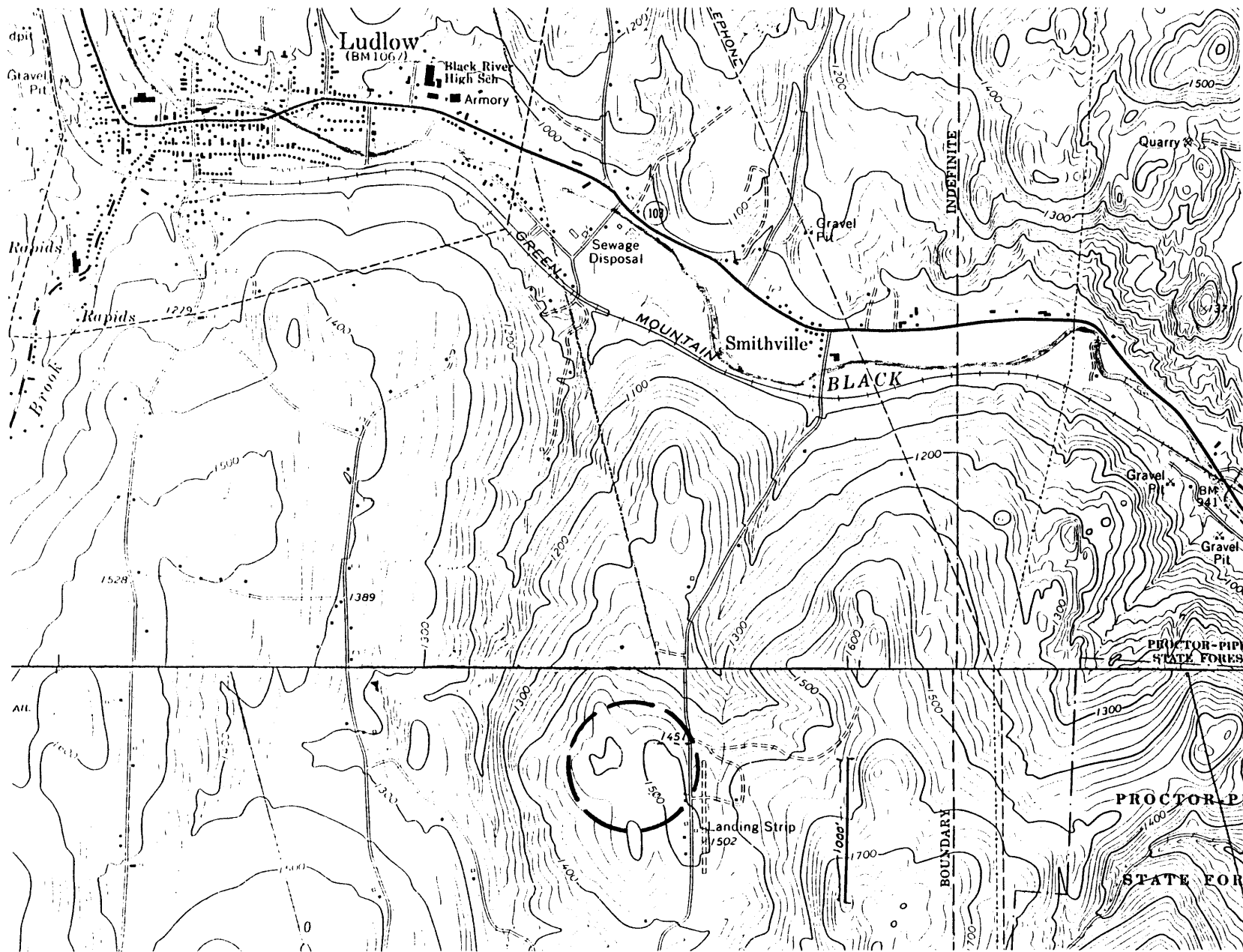



but it is only in the last few years that its inhabitants discovered what they were sitting on. Bob Smith purchased the bulk of the hill and subsequently discovered large quantities of talc which today is mined from several areas. Winsor minerals was thus founded, and Bob owns controlling interest as well as a private airplane and airstrip on the hill.

Only about a dozen families live on the hill, and that's OK. They are not eager to develop it. When a small 10 acre tract came on the market in the early 1970's it was purchased by four friends from Massachusetts who liked the idea of a second home. Three of them eventually built on the land, the fourth has other concerns.

The land sits squarely on the top of East hill, on the crest of two watersheds. A fine stand of mature beech / birch / hemlock forest covers the site, making it cozy but minimizing distant views. (you have to go to some adjacent pasture to see Okemo or Bob's airstrip to see how beautiful the distant views are.

The climate at the top of the hill is significantly harsher than in Ludlow. It is wetter, colder and

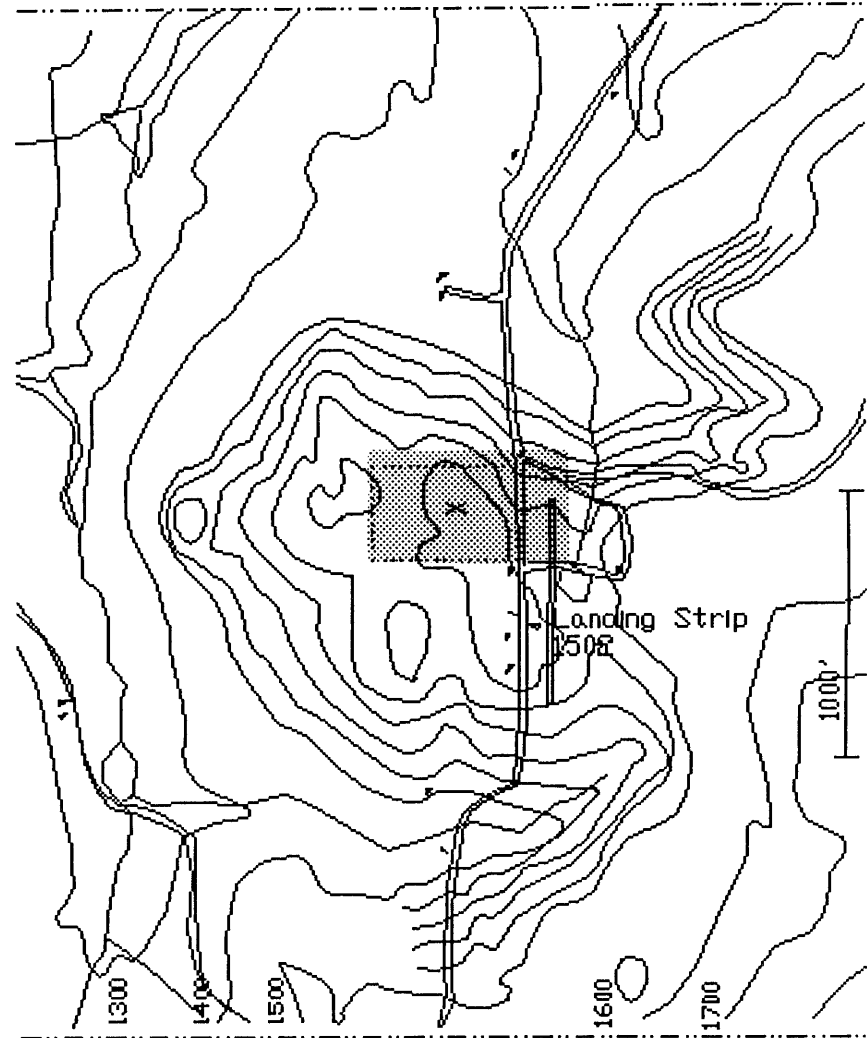

windier; a drizzle in the valley means inches of snow on East hill.



This transformation focuses on Russ and Marilyn Nord's house, a 1972 vintage builder's cape. With a little help from his friends, Russ layed a 20' by 30' concrete block foundation directly on the bedrock, and one sunny day Russ's house arrived on the back of a truck. Fully sheathed walls, with windows and doors pre-hung, were tilted into place and nailed together. The shell of the house was done in two days. Russ has been slowly finishing it ever since.

The house is sited such that the land slopes away to the east, north, and west. The driveway approaches from the south. The surrounding land has been minimally disturbed. When constructing the house, Russ cut a hole in his deck to allow a small hemlock tree to continue growing. The hemlock is now larger than the house.

The house itself is exactly a cape, it's simplicity is it's charm. Its second asset is the landscape, which glorifies this humble building making it appear to be a significant oasis of dwelling.

The house actually feels very removed from it's environment, excepting the deck you are either inside of outside the house. One set of sliding glass doors

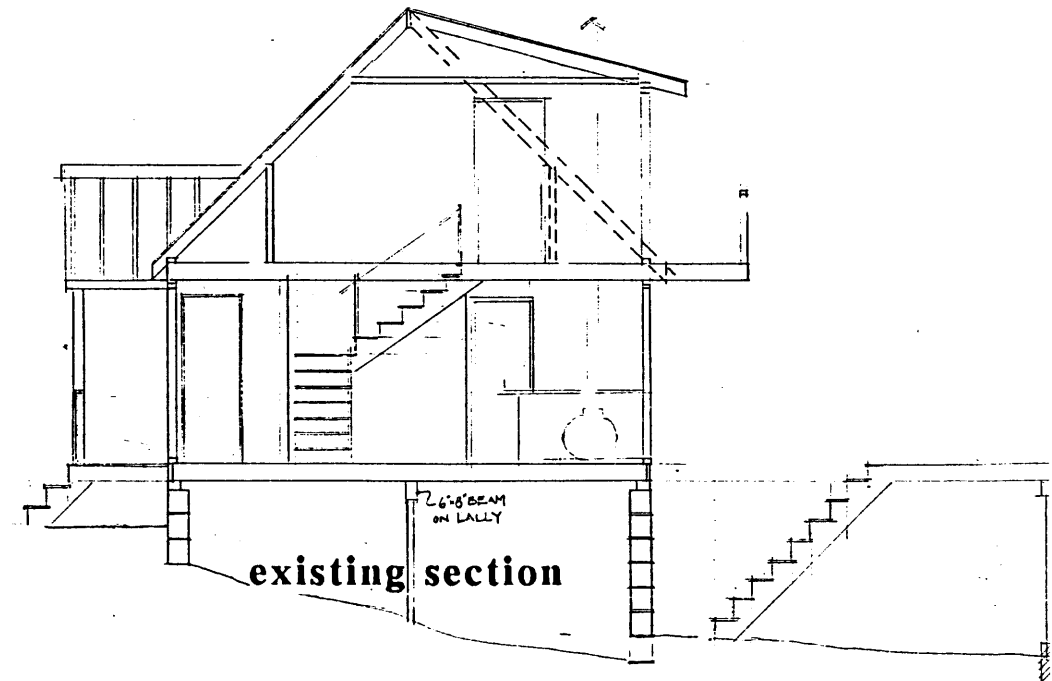
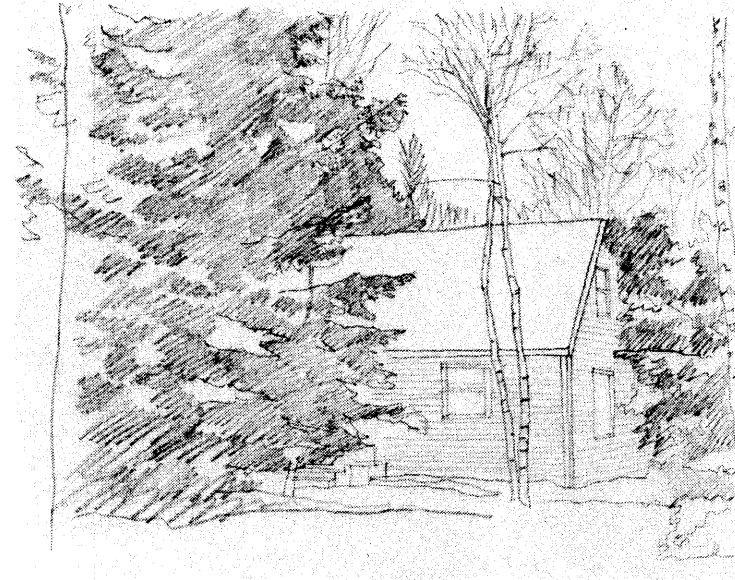

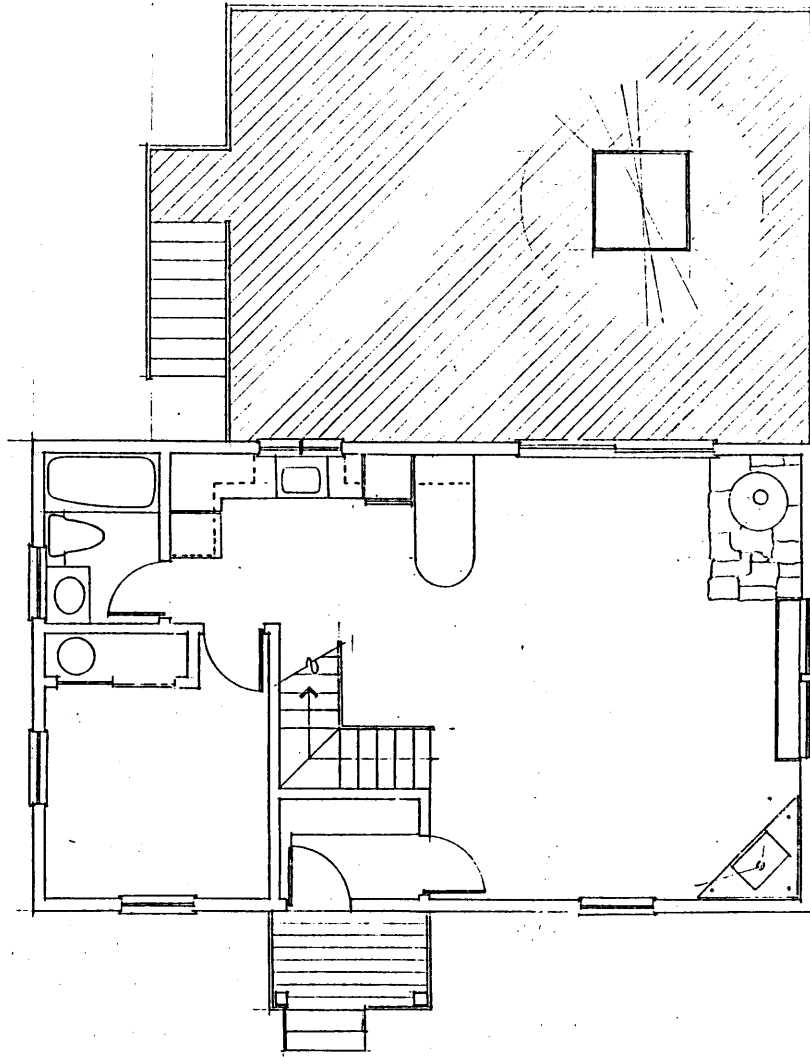

existing first floor plan
scale: 1/8" = 1'-0"

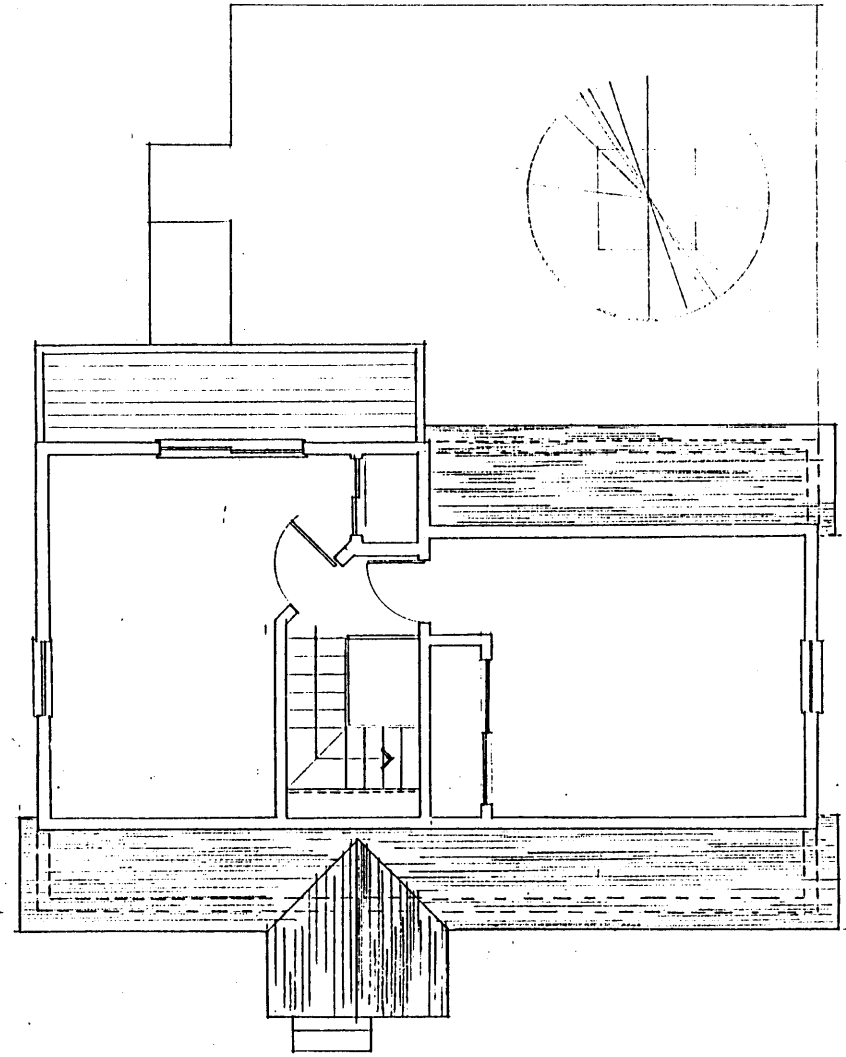

existing second floor plan

allows a view outside, otherwise one is isolated within a subdivided box. The 7'-6" ceilings feel oppressively low because nowhere are they higher. There is no sense of vertical continuity. There is no hearth. A charming ceramic woodstove is provided with a corner where the wall is shingled with slate, yet the effect is two dimensional and less than fully satisfying.

In the transformation, I have kept the existing program, and added a garage, hot tub / sauna area, and a guest cabin of 384 square feet in area. Aproximately 100 square feet of floor space was added to the existing house along with quite a bit of deck and porch area.

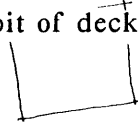

The intention in this transformation was to extend the range of experiences available within and in the immediate area surrounding the house. Spaces are designed to overlap in plan, section and use, to encourage variable activity oriented meanings. In this manner I hope to integrate the house more completely to it's site and allow many definitions of dwelling to occure.

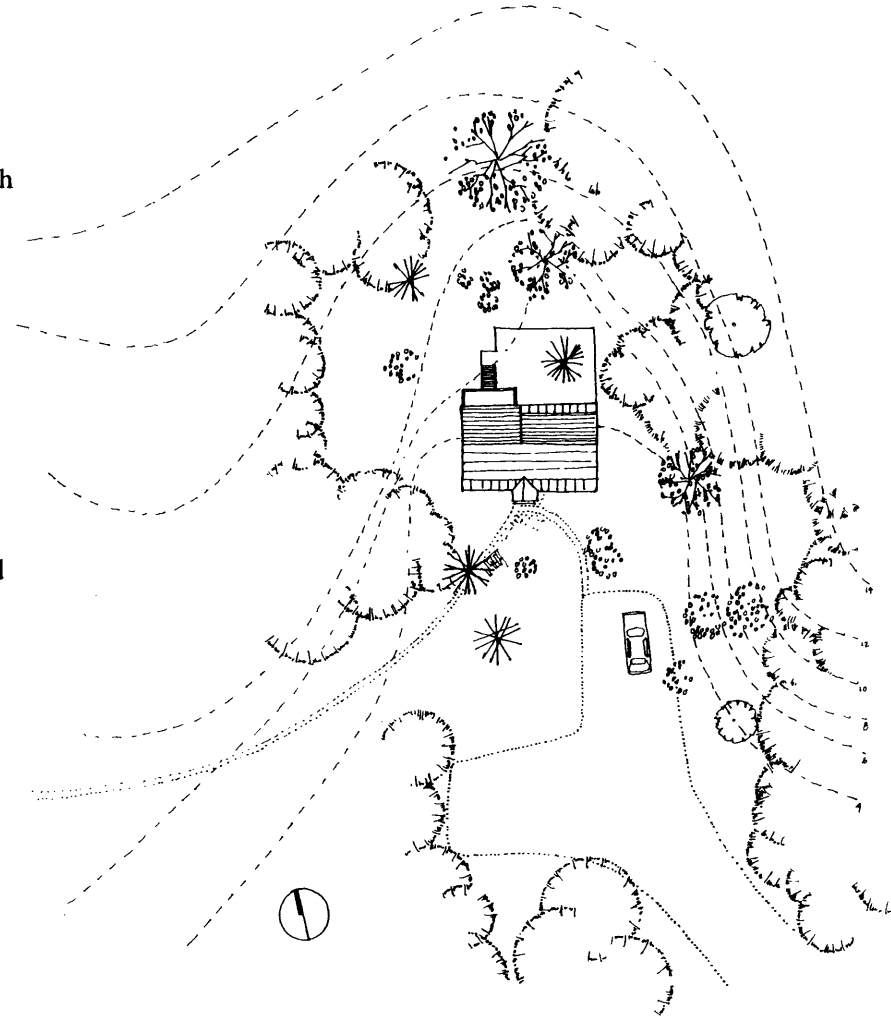

existing site plan

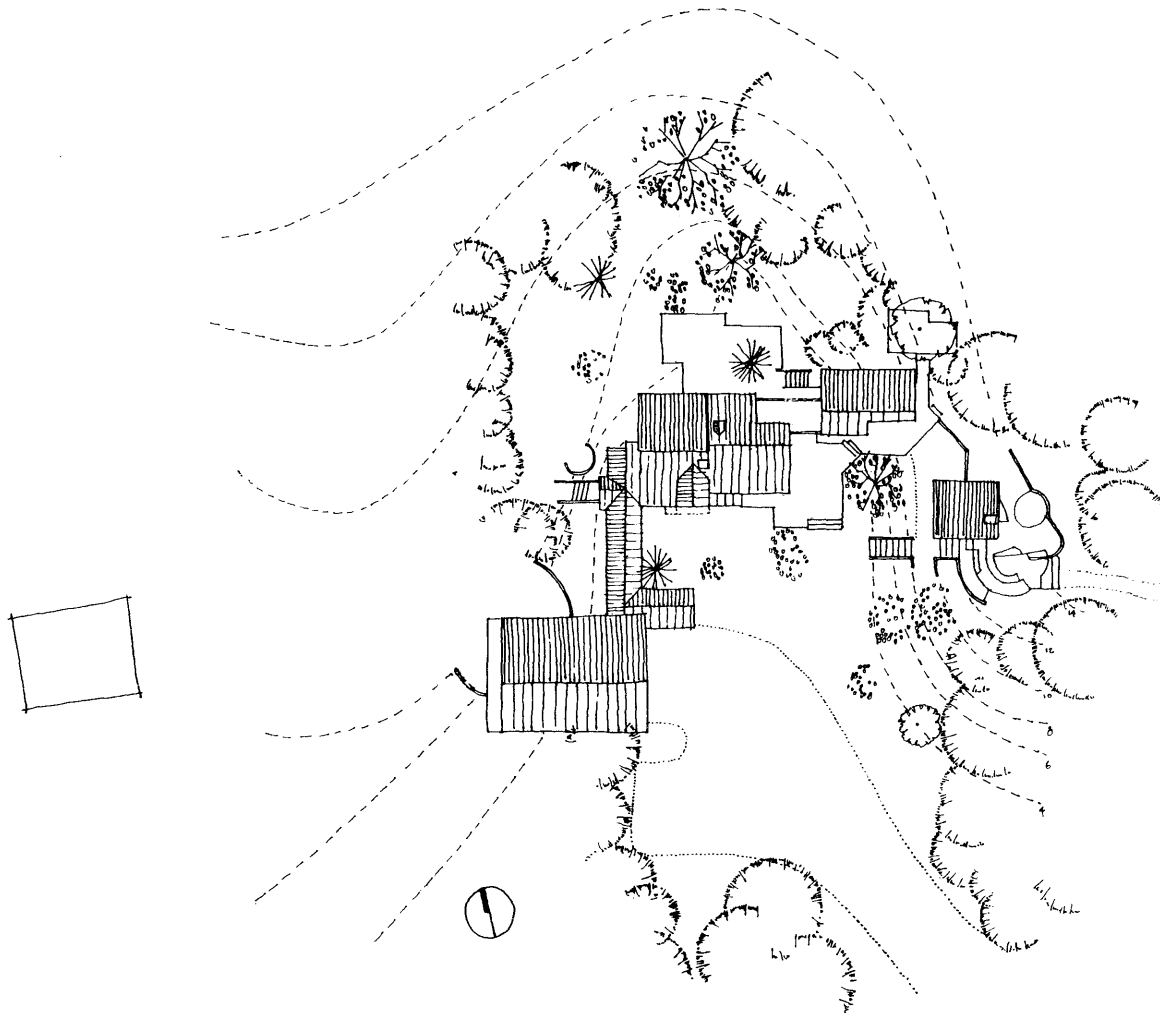

proposed site plan

scale: 0 30 50 100

The house begins to lay claim to the land at the entrance to the site with a mailbox / light fixture. A series of low ceramic light fixtures along one side of the driveway lead to the house. The house itself appears to ramble a bit, like a Vermont connected farmstead.

The garage is connected to the house with an entrance breezeway. This is followed by a porch and another small dwelling, some more deck and some steps that go down the hill and out of sight. The garage has a somewhat modern rustic quality, it feels more like a barn. This Craftsman style aesthetic is combined with the angled New England "good luck" window, and repeated throughout the complex. Large exposed trusses rest on ceramic columns; a window system is integrated into the trusses. The sheathing is applied independently of the structure; it can slide and open up the barn to the outdoors. The doors lift up and slightly out when open, extending the sheltering roof. The barn is approximately the same dimensions as the original cape, and in its simplicity, preserves its memory.

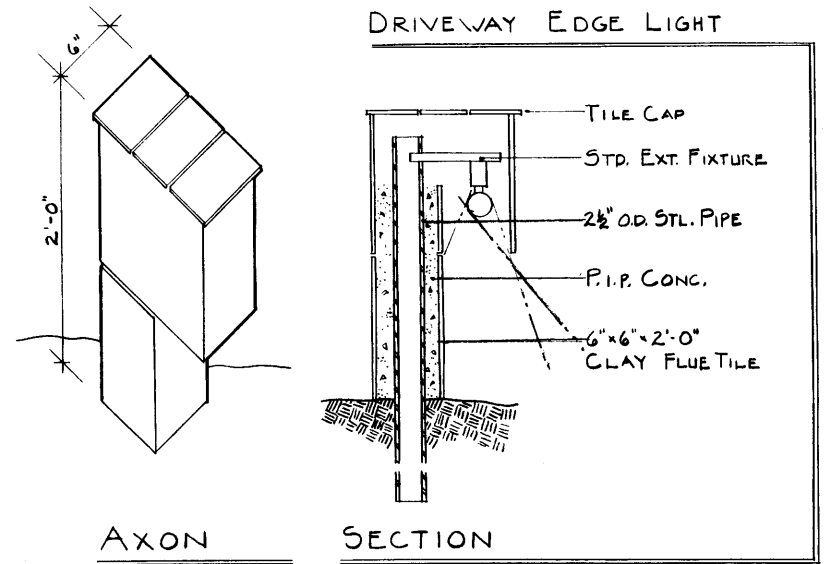

mailbox / light fixture

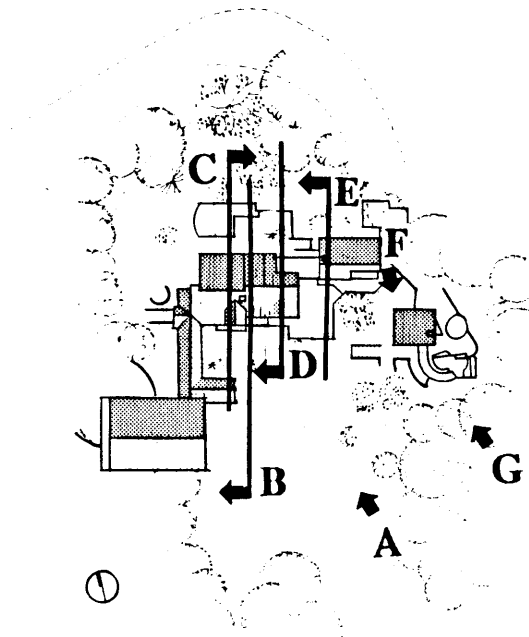

key to drawings



VIEW A : upon arrival

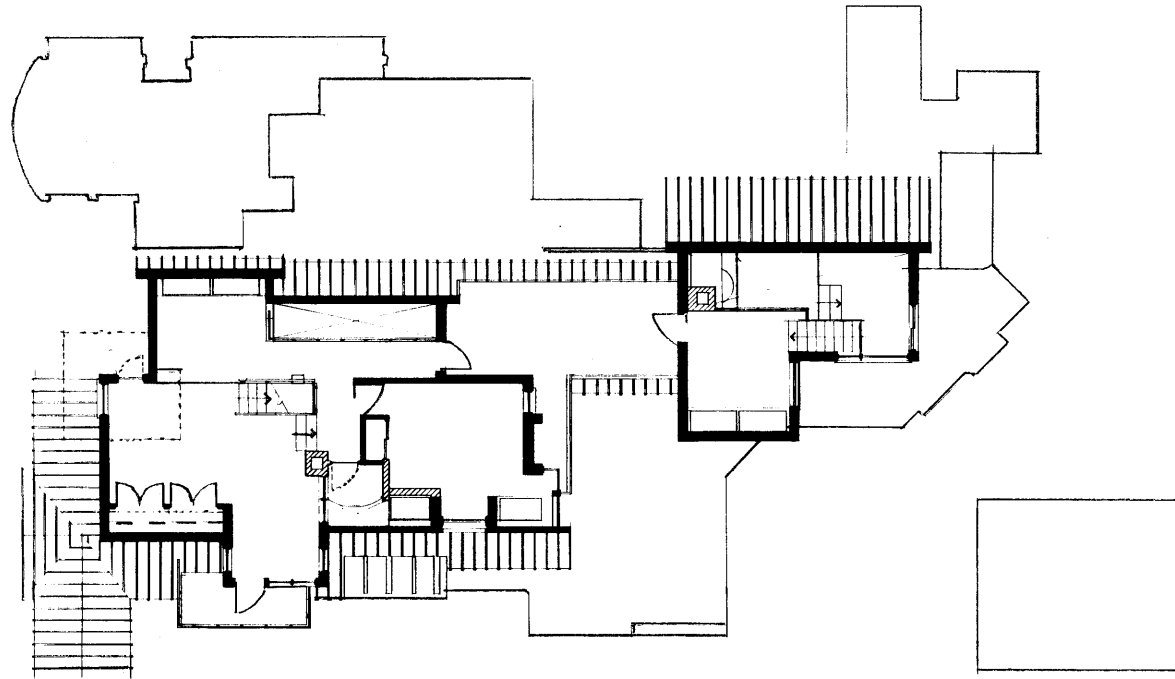

second floor plan

scale: 1/16" = 1'-0"

2 5 10 30 50

The entrance to the breezeway is anchored by a slate seat. The breezeway adjoins the barn, winds around an existing hemlock tree and leads to the entrance of the house. The breezeway is also built of ceramic columns. Terra-cotta flue pipe is filled with concrete and rebar, forming a stable and tacitly attractive colonnade. Steps lead down into the west landscape and the lower storage level of the barn.

Going east, the slate pavers continue into a greenhouse entry vestibule. Inside, the terra-cotta columns form the support for glazing mullions and curtain walls. The greenhouse has operable glazing to the outdoors as well as to the dining room and upstairs rooms. This space wraps around the living room fireplace and up two steps to enter the house proper. The greenhouse ceiling rises with the slope

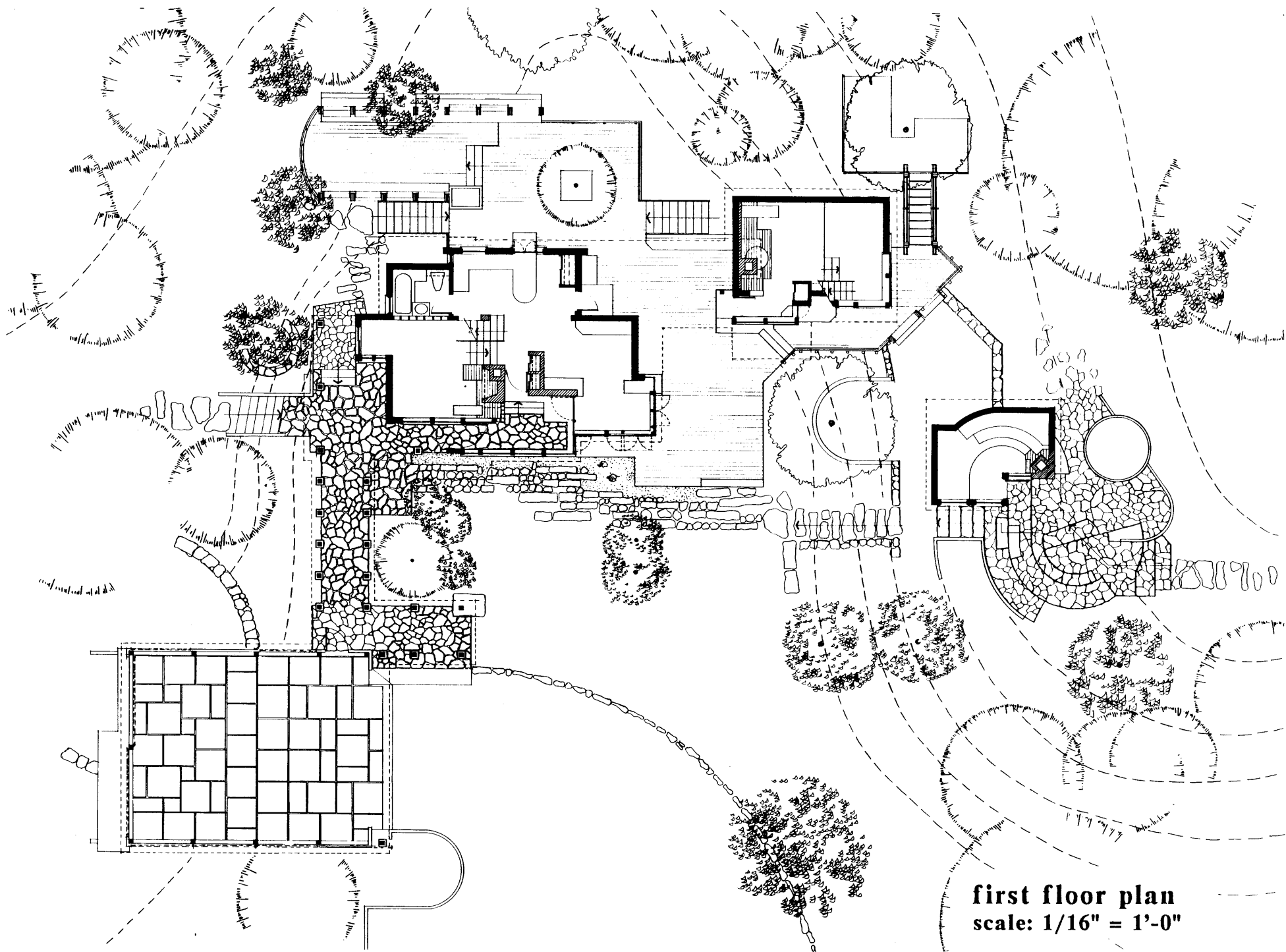

first floor plan
scale: 1/16" = 1'-0"

of the roof, vertically connecting five different floor levels.

The interior spaces all interpenetrate, defined by partial walls and level changes. Several areas are open above. The house is generally open to the south and closed to the north. Upstairs a room sized gabled bay overhangs the entrance, and opens up to a small porch. This room is actually four rooms; the main room, the bay area, a small loft, and an even smaller crow's nest that sneaks outside to a rooftop lookout. This whole area is toplit by sunlight scraping across the ceiling.

Up three steps is the master bedroom, parallel to the balcony overlooking the kitchen. This bedroom has windows looking into the greenhouse, dining room, study, hallway, and outside to the south and east. These windows are so located that it is difficult to look in them and disrupt the privacy of the bedroom.

SECTION B : through greenhouse

scale: 1/8" = 1'-0"

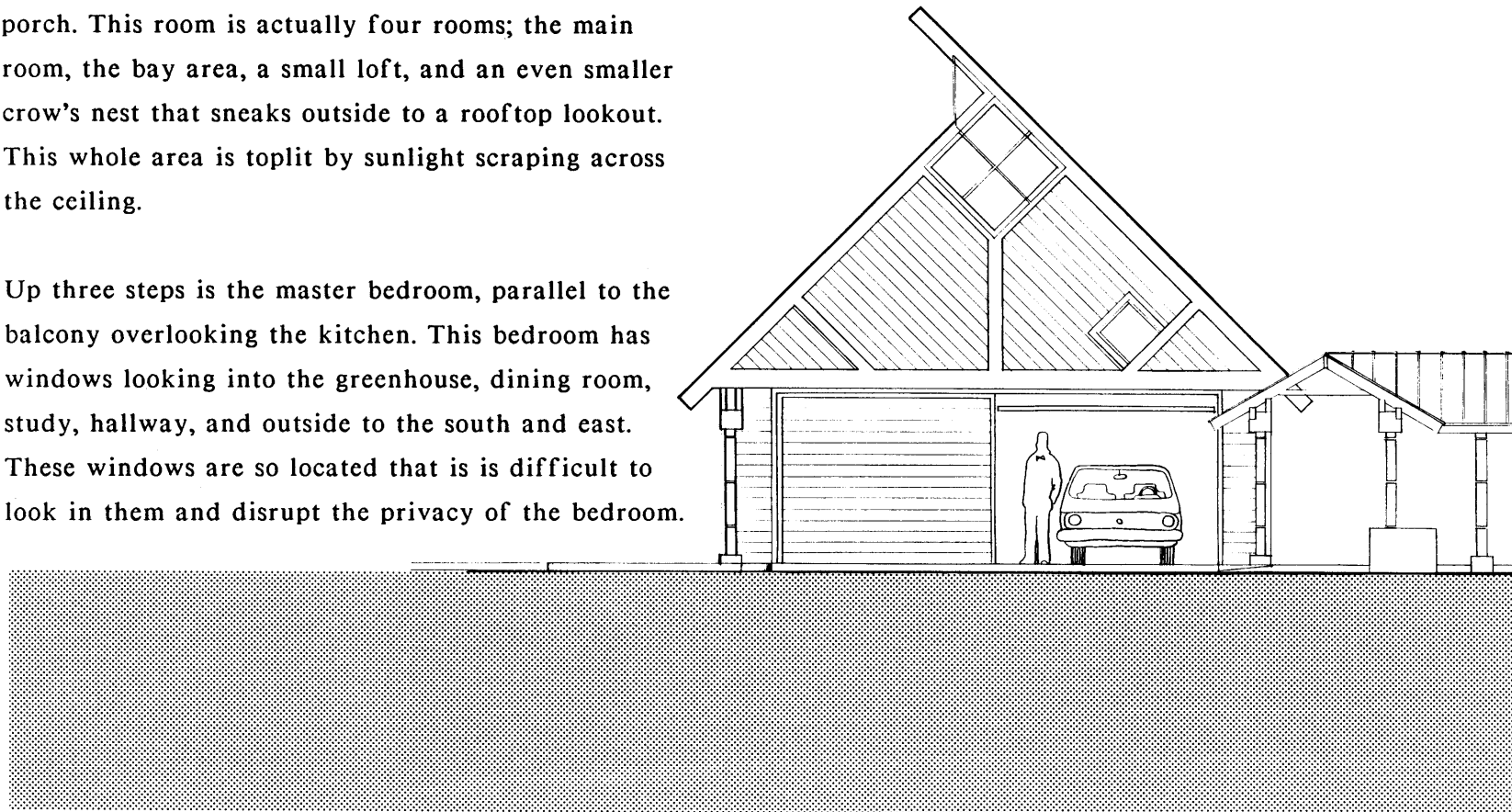

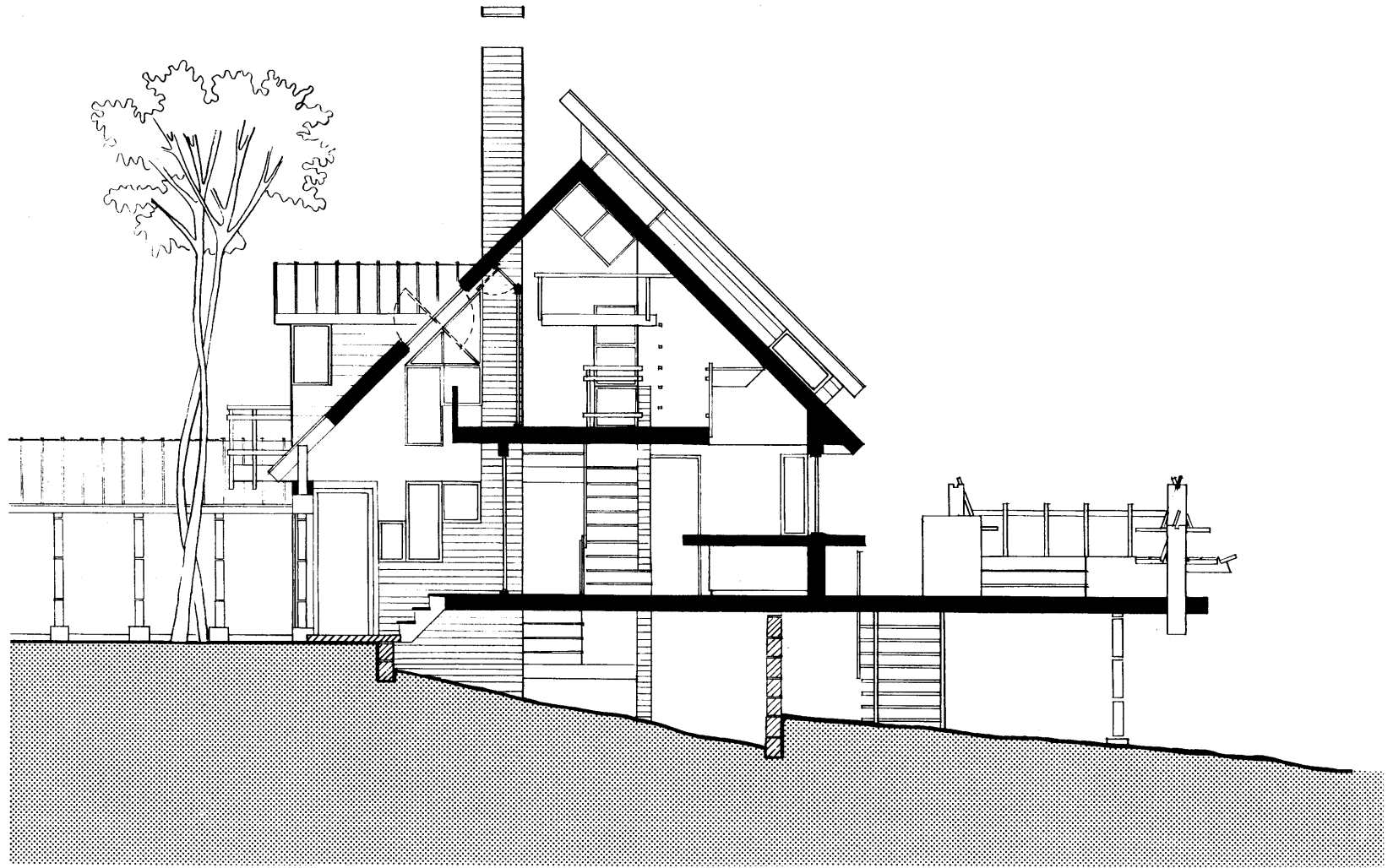

SECTION C : through living room, upstairs dormer

scale: 1/8" = 1'-0"

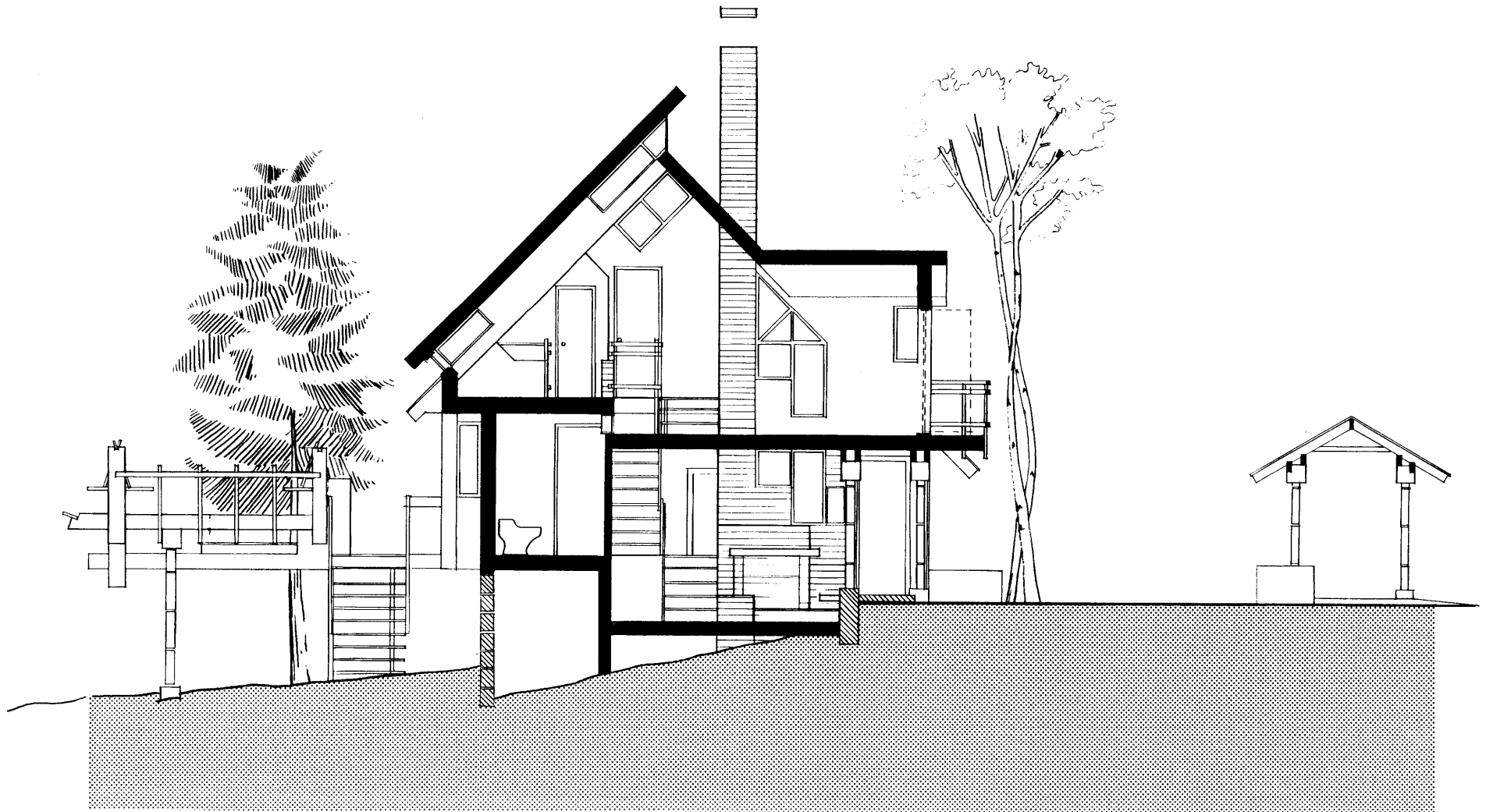

SECTION D : through dining area, main bedroom, flying deck

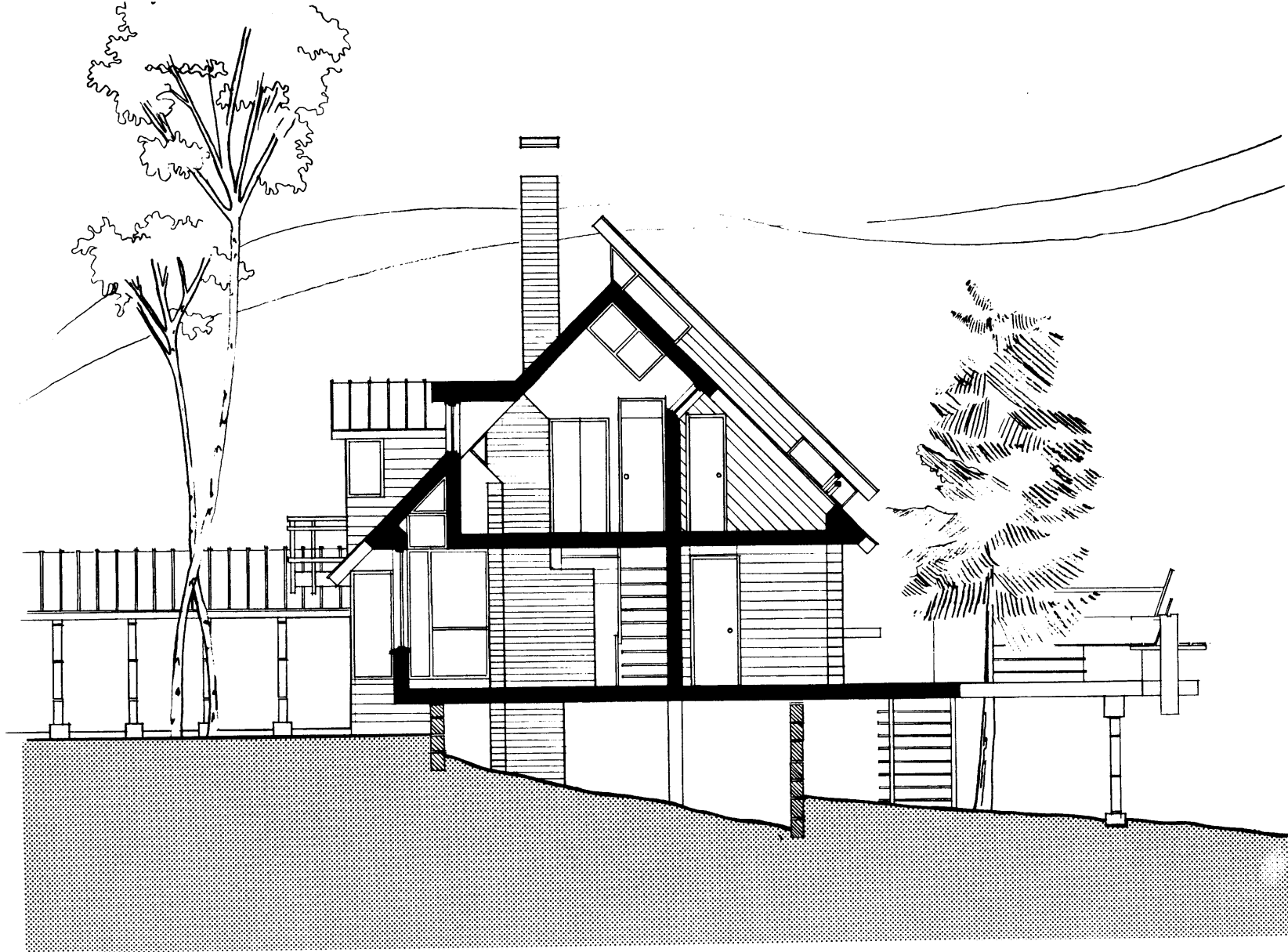

The bedroom has a small porch to the east, which can also be reached by the balcony hallway. The bedroom porch adjoins a "bridge porch" which connects the main house with the cottage. This "flying deck" affords a view almost 360 degrees and is perfect for summer cocktails.

The cottage is a simple affair, completely separated from the main house. It is pushed east onto a steep slope, and therefore stands on poles. It is without plumbing, but does provide a hearth for the small ceramic stove to rest in. The cottage is small, sunny, and somewhat saltbox in form. It opens onto several decks, which can lead to the shagbark hickory treehouse, or down to the sauna area.

SECTION E : through cottage
scale: 1/8" = 1'-0"

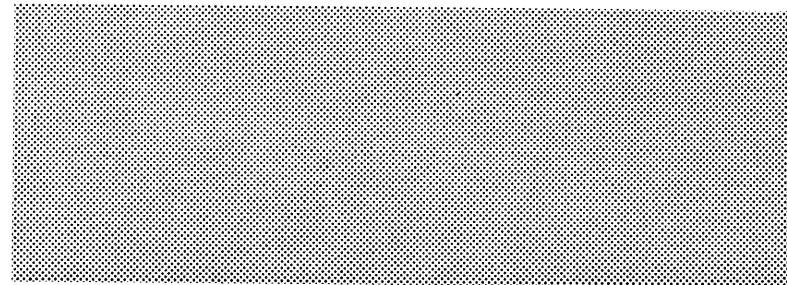
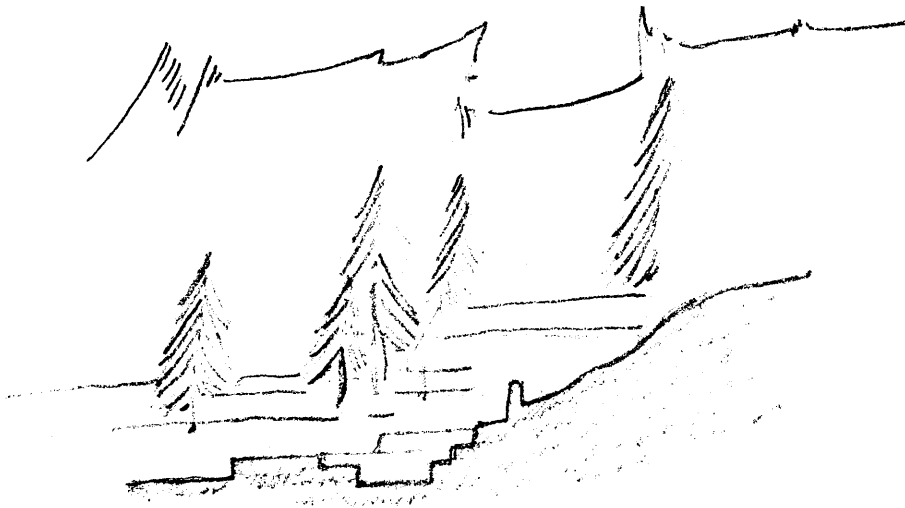

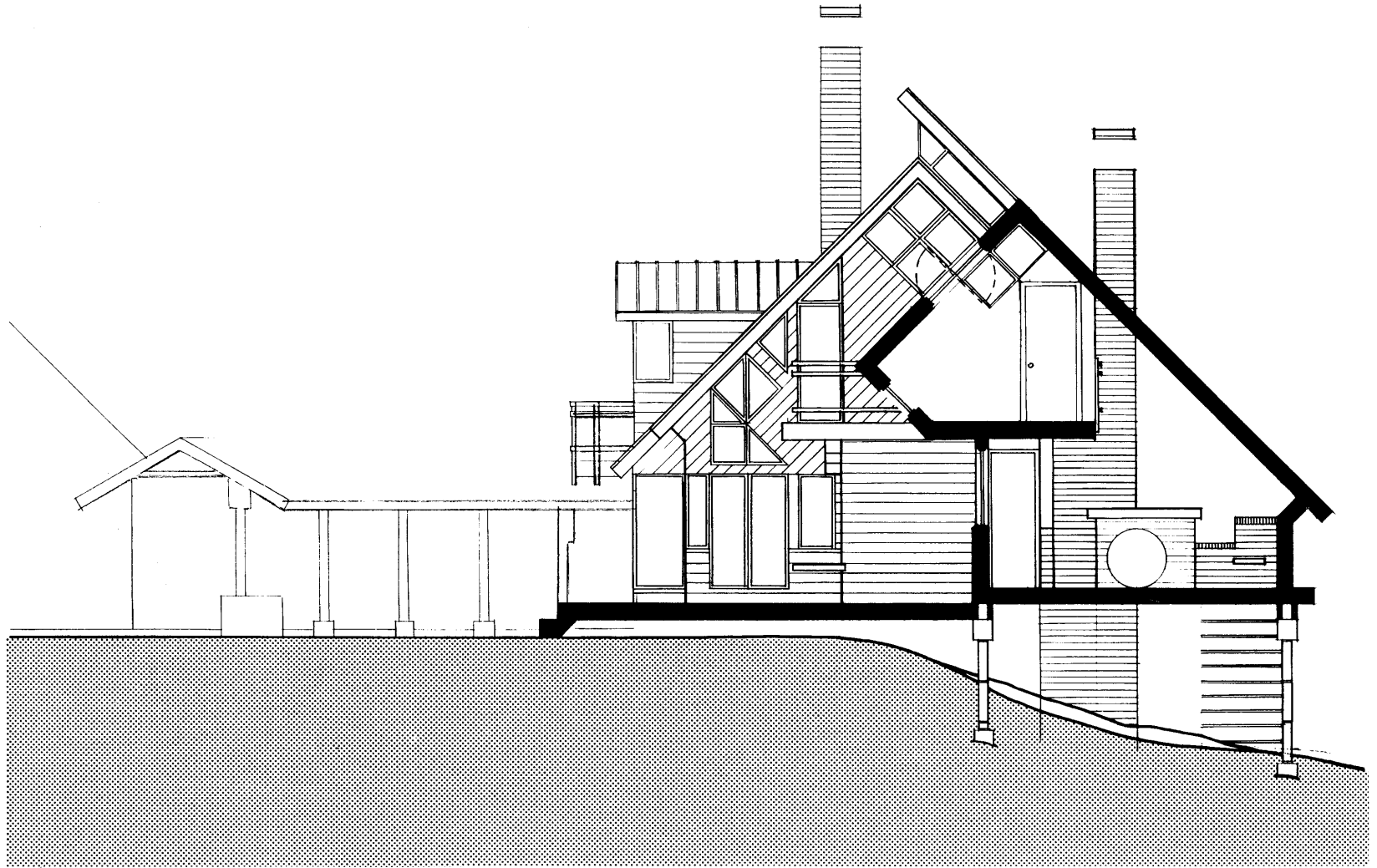

One must descend to the sauna, down the steep east bank where the building is buried in the earth. Descending further, one finds the steps widening into a small amphitheatrical sitting area, followed by a small plaza with a sunken hottub. From here it is possible to continue on into the landscape, or enter the sauna, with its gently curving benches and reassuring masonry stove.

The overall effect of these paths and nodes is a series of spaces and interspaces which offer many ways of being used. The spaces between the built areas are used positively and their significance emphasized. In this manner I find architecture to have an organic relationship to the site.

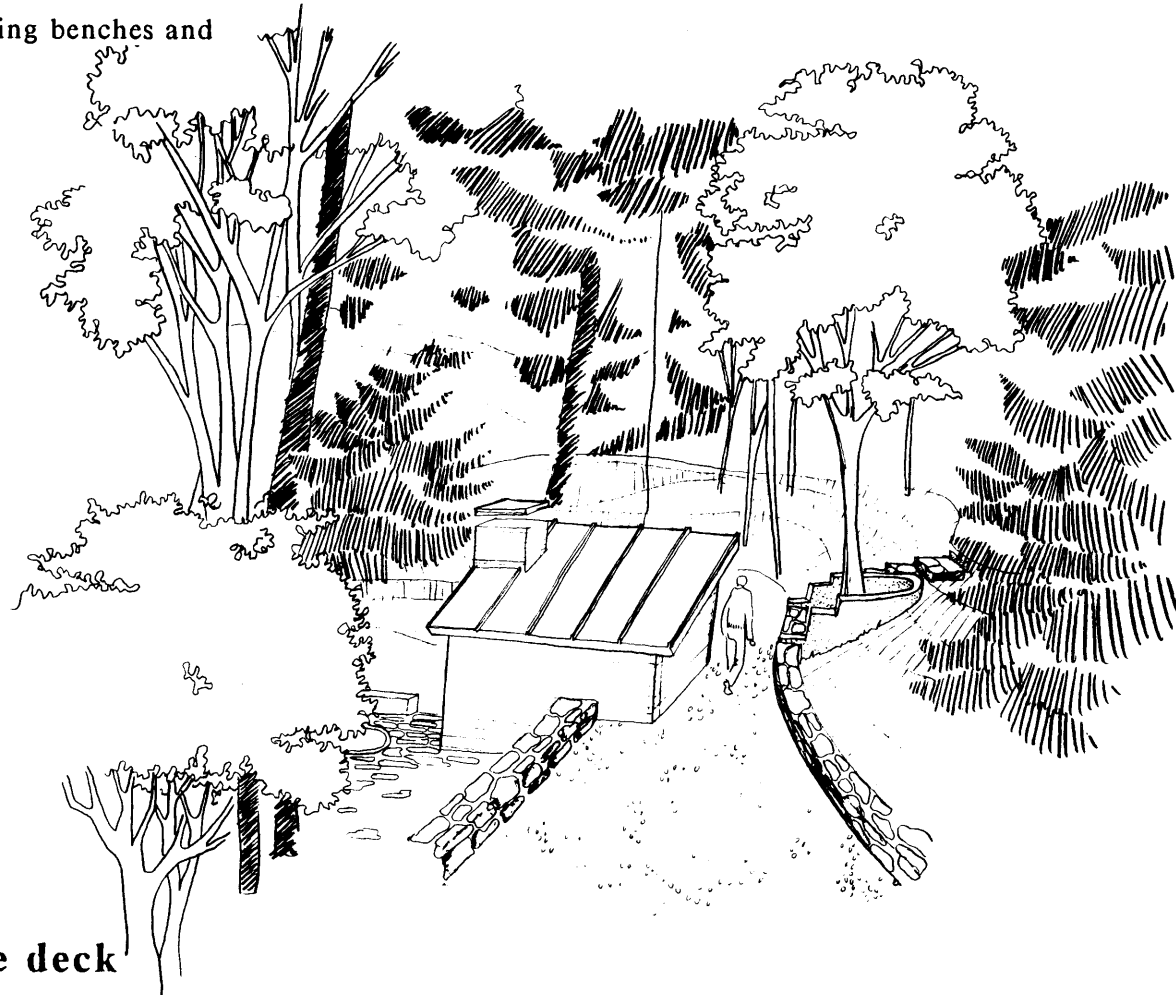

VIEW F: from cottage deck

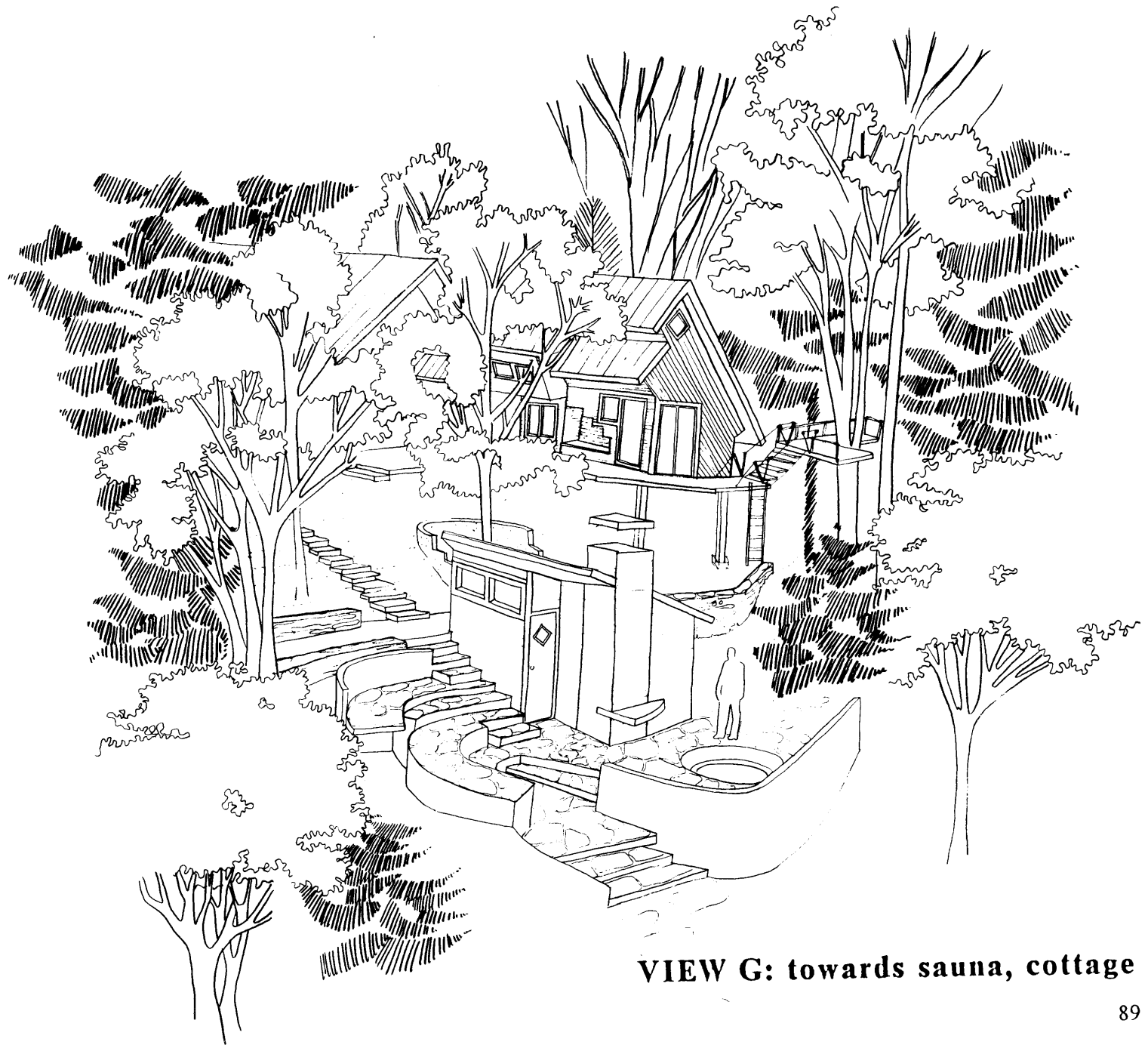

VIEW G: towards sauna, cottage

detail at deck edge. bench with reversible / removable seatbacks

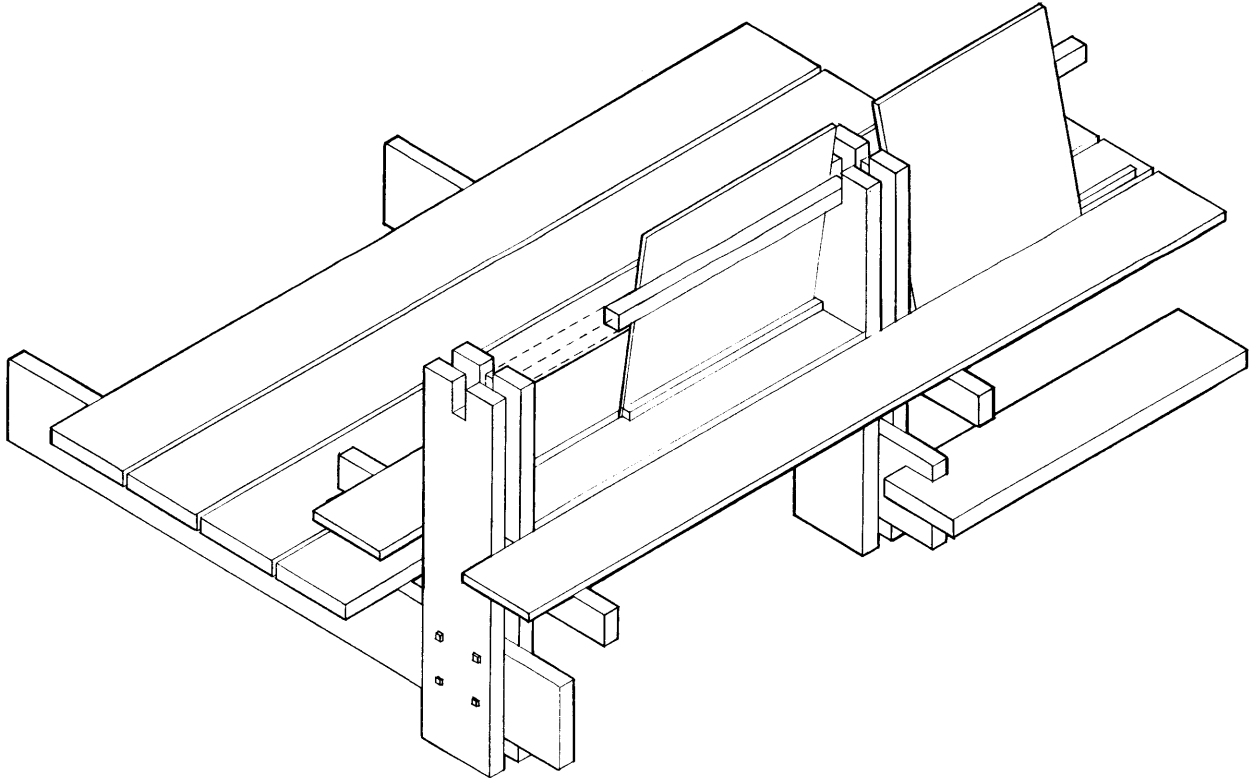

energy analysis

The use of energy in a building is a relatively objective criteria for evaluation. As shown in the previous chapter, energy use is an important criteria in deciding to purchase a building. Minimizing energy use in a structure can contribute to owner satisfaction for a number of reasons, for example reduced operating costs, a moral satisfaction with treading lightly on the earth, or the security that comes with being increasingly independent of external energy systems. While the cost effectiveness of the proposed measures is doubtful (and subject to mid-east world politics) the objective decrease in energy consumption is the factor here considered in increasing the desirability of the dwelling.

In connection with this redesign several energy related construction details were considered. Actual energy bills for this cape were tallied, and averaged. The existing house was then modeled on a microcomputer using Berkley Solar Groups CALPAS 3 energy simulation program, and the results were correlated. The transformed dwelling was then modeled, and the results are shown here.

In the transformed house thermal mass was added, the amount of south facing glass was increased, the area of north facing glass was decreased, the walls were insulated to R 30, the ceiling to R 40, and all glazing replaced with R 4 Heat Mirror. The proposed energy use was approximately 25% of the existing condition.

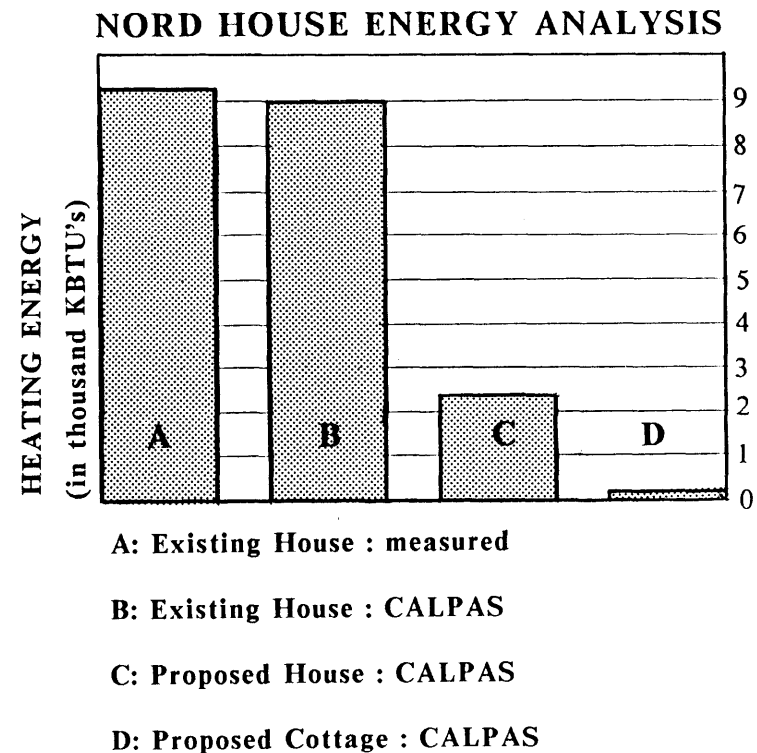

"Fotografia a contrallum, de dos persones joves assentades, que sem-
blen estar conversant. Els elements ambientals i de indumentaria (moqueta, cor-
tines, coll i corbata dels fotografiats, etc.,) situen l'escena en un ambient
benestant, pel cabell curt i les sabates brillants i punxegudes, es dedueix que
la foto no és molt actual, pot tractar-se però, d'un centre universitari o d'edu-
cació on s'exigeix una certa uniformitat anacrònica.

They wait for the results
Will Jack be King
And Bob be Jack

This could be a photo of historical importance.
This could be a masterpiece.
This could be a reason for a new art to begin.
This could be worth \$ 1.000.000
This could be a reason for books to be written.

YOU KNOW WHAT, ROBERT? TONIGHT I'M REALLY TIRED. YOU GO TO BED WITH
MARILYN.

President J. F. Kennedy and
his brother Robert discussing
~~politics~~ in an empty bed-
room of the White House.



after muntadas "on subjectivity" 1978

the worlds in a city

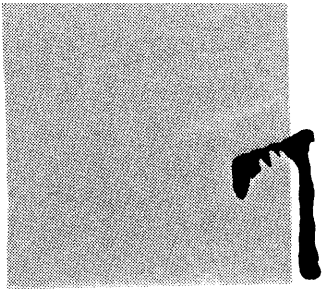

subjectivity at home

Discussions of architecture often reduce to an authors subjective viewpoint, which is presented as universally valid. Upon inspection, it appears that the subjective nature of interpretation may be the most consistent phenomena. A series of interviews were conducted, to introduce a subjectivity not of my own making. This "rank empericism" is not meant to provide comprehensive, conclusive information on which to base design; what it does is recognize several reccuring themes in the idea of dwelling.

Interviews were conducted with a number of people, of which six have been selected for analysis and description here. All interviews were conducted in Cambridge, Massachusetts between 11-1985 and 2-1986. The interviews were conducted in person, in the interviewees home if possible, and tape recorded for later transcription.

The interviews were structured around the question "What makes a house a home?". Subjects were asked this question at the beginning and at the end of the interview. (see questionnaire) . The format was intentionally left flexible in order to create a non-directed aspect and encourage associated thoughts. (1)

The final participants included three women and three men, referred to respectively as F1, F2, F3 and M1, M2, and M3. The basis for their selection was as representing a variety of lifestyles. M1 is a homeless man, M2 is a student of architecture, M3 is a recent immigrant from India, F1 is an increasingly affluent woman, F2 is an often transitory artist, and F3 is an elderly woman who has lived within a one mile radius of her present home for all of her 80 odd years.

The interviews are here excerpted (indicated by italics) to illustrate dominant points brought up during the interviews. The complete interviews are in appendix A.

INTERVIEW OUTLINE

PURPOSE: Understand what makes interviewee consider a place "home"

QUESTIONS:

What makes a house a home?

Where do you live now?

- For how long have you been there?
- Do you like it ?
- What is the best/favorite spot there?
- What does it look like?
- Why did you move to here?
- Whats the worst aspect of it?

What is the nicest place you have lived?

- Why?

Where did you grow up?

- What did it look like?
- How long did you live there?
- Have you been back recently?
- What did you think about it now?

Which (of these) places do you consider home?

- Why?

What is the best (or strongest) feeling/memory about the places you've lived?

What makes a house a home?



If you could close your eyes and click your heels three times, where would you land? i.e, what is your ideal "home"; where is it located; who is there; what does it smell like; look like;feel like; hows the weather; landscape etc.

analysis of interview f1:

The kitchen is a crucial element in this person's conception of home. This aspect of home carries almost every association, biological activity, as well as the spiritual symbol of hearth.

"The kitchen seems to be the center...You're like nourishing, and enriching and creating..That's what I envision as being real homey. Fireplace, and smoke coming out of the chimney."

The kitchen also serves as an analogy for the whole house.

"(a home) has to be usable, it has to be workable for whatever you're doing in it, like a kitchen, say."

Home is here also understood as control over the environment, independence.

"It'd be more of a home if I owned it"...make your decisions about how you want to split it up"...my favorite part about the house was that the kids had the upstairs...there was a door so it was like a private apartment.."

Both anonymity and inhabited personalized spaces were considered attractive images of home, rationalized as the combination of technology and primitivism. This was also manifested as a sort of biological memory informing the present.

The nicest place that she had lived was described as

"a little community of little huts. Grass huts. With cement walls and little chameleons climbing on the walls. It was great. It was perfect for what it was, it was shelter... Well, I'd bring in the modern conveniences..God forbid my Cuisinart can't come along!! Well I think it's a combination of primitivism and technology. I'm not against technology it's an incorporation of the two, cause I think that's really important. In primitivism, I'm merely saying that it's part of our nature it's something we should never lose touch of, which people do. You know, we forget that we're human, and so that's my part of that. And the technological part is like this IS, we are living in 1986, and we might as well take advantage of that, also. It's kind of like the best of both worlds, you know, everything."

A final note recognizes that the concept of home

resides in time and memory, rather than in the object. Speaking about the house she grew up in;

"I went back a couple years after we sold it, just passed by. It was real depressing, you know, like getting rid of it, it was real roots, childhood stuff. We went back, but there's kind of no point to even go back and look at it, you just kind of go back and say "this is where I grew up", the house didn't hold the same, it didn't have the same aura at all, you know, new people moved in, and that's it, it's totally different, it's not really a house any more. The house is imaginary."

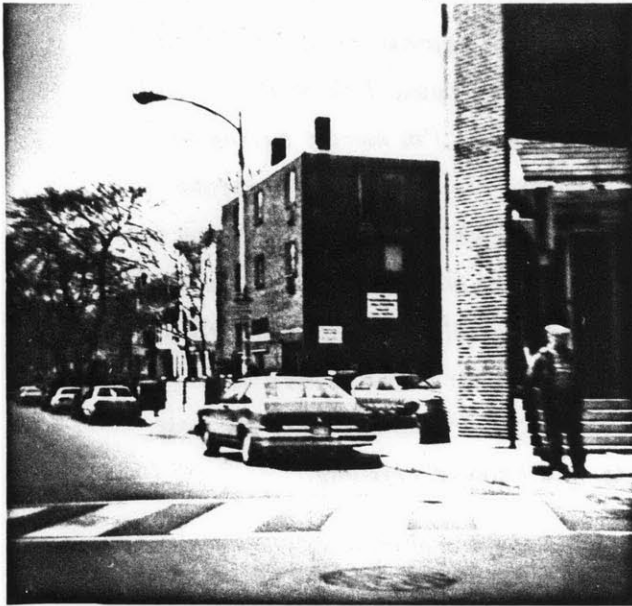

analysis of interview m1:

My overall impression was that the house has a deep symbolic value to this man, carrying memories and images of accomplishment. His first definition of what made a house a home was

"Home is children"..

Questioned further, I asked if he considered a certain place home.

"Oh sure, --I made that place"

This definition focuses on the act of dwelling. This emphasis on constructive process is an almost literal translation of Heidegger's definition of dwelling, "Building is really dwelling", an activity related association.

"Rebuilding a house and especially with my own hands - That to me was much more interesting and much more like a home"..." An old house that you could work with, and try to make into ...I suppose your dream "

This man had a severe clarity of definitions, perhaps born of his living on the streets.

"A house is a house..a home is where you live"

A purely symbolic association with home effectively dematerializes the home. In this manner, M1 describes home once again as the fruits of his activities and associations with it.

*"Family, love, accomplishment,..I can keep going.
That's a lot more than a house...A house is nothing."*



analysis of interview f2:

Many of this persons associations of home had to do with memory and mystery. This occurred on a personal level, but also on a collective level, leading to a desire for temporal continuity of past, present and future. The perception of being a part of this continuity provides a feeling of security, and thus of home, in a very traditional sense. When asked which childhood house was considered most "home-like", the reply was:

"The one with my grandparents."

Question:"And was that because you enjoyed it the most?"

"Because I was the most secure there."

"Okay, if I could have exactly what I wanted... it would be an old house.. I would invest in antiques. I prefer older things to modern designs. When I see people's houses that are designed in modern, high tech, whatever, I like them, but I know it's not my style."

Question:"You think it's a matter of style of antiques and old houses, you like the style of them, or is it a sense of mystery..."

"It's the sense of mystery, it's the sense of having continued, it's the being part of that continuity."

Question:"If you got a bureau that was just made, but hadn't been-- it didn't have any chips of history of other people having used it, it might not be as important?"

"No, it wouldn't be, it has to have that sense of having been used."

"..There was a lot of mystery about that house too because it had this feeling of continuity, because other people had lived there, and it had belonged to the family for quite some time, and all the other separate histories that it had been in. I'm really fascinated living in houses that have existed and have--the charm of old houses."

Mystery arises in the personal history as well as describing a childhood home. Discussing revisiting the childhood home;

"I was curious to see what they'd done to change it, but at the same time I was kind of dreading it, going in to see that it was not the same place anymore... It was a room that had nice light, and it was a big room, and it was mysterious. It had two beds, a bureau and a closet, and the closet was extremely mysterious. It was filled with boxes and things--I was fascinated with what was in there."

There were several important discrete images in this interview that were difficult to relate except perhaps as examples of "visually rich" environment. Perhaps this is indicative of her artistic perceptions.

"The dining room was fascinating to me too because it had this wonderful wallpaper of Venitian boatmen... it's...the wallpaper in the diningroom is something that really strongly holds me..lot of hangings, a lot of paintings, just little kind of-- rich, rich and--visually rich. Yeah, a lot of texture, I like beautiful fabrics, embroidered fabrics, I like to have paintings, I like to have sculpture,..For me I need lots of visual excitement. Because it's so bleak outside, I want to have rich colors."

Masonry was also noted several times as having favorable connotations. This is consistent with the common perception of masonry as a relatively "permanent" building material, and the interviewees' desire for temporal continuity.

"..there are several houses that I really like. There's this stone house... and a brick house,...the stone house had some small rooms and fireplaces and a cookstove. And the wide windowsills, I always really liked that.

analysis of interview m2:

A home is "a place where I can stretch out" according to this person. This statement talks to a lot of concerns, for a quantity of space as well as to the idea of the space as being user defined. In this way the home becomes the "back stage" providing privacy for the occupant to do as they please. Some aspects of home were highly dependent on the people involved.

"Feeling at home there had a lot to do with the people".

Question:"Do you like it?"

"Yeah, it's a really big household"

In this example, the living situation seems to have often limited the independence of M2.

"I guess the biggest drag is ...we don't ... have free reign over what happens in the house. I think it's really important to feel like you can drive nails in the walls or tear down walls, replace front doors, things like that without having to report to someone."



Question:"So if i ask you "whose house is this", how would you answer?"

"I would probably say that I'm renting it, which implies that it's not mine to do with as I wish. And it is a drag... that's that freedom, to do whatever you want, I mean it's your own space to destroy or not.."

The physical organization of architecture often influenced the desirability of a space, the desire for a cozy room for sleeping, with a direct connection to the outdoors was mentioned several times. These small spaces are easily "claimed" and allow for a comfortable distinction of ownership.

"My bed is right under (it's a very nice place, not because its architecturally great, but because there's) a small skylight right over where my head is at night ...so I can see out through the roof and I can see the moon, I can see the stars at night,.. The benefits of having that experience of lying down and looking up at the stars every night is just really great...it's right up underneath the roof. I like it as a sleeping chamber because it's really small,..I don't mind having a really small bedroom "

"..this little shack...it also has a huge skylight in the roof which you can see everything out, the moon, everything...you come out into the backyard,.... my bedroom was just big enough for a double bed.. And there were windows on two sides starting at the level of the bed and up and those two sides were completely windows so you could look out while you were in bed, straight out the windows and look out over these fields. Just incredible space.."

"...that intimate space of bedroom..like your own spot, and it's not a big spot either, it's a low ceilinged spot and often it's because the roof is part of the ceiling, it's got you know that corner knocked off of the room. In all the places, there is accessibility to the large space, outdoors ,in general, that makes that smaller intimate space like a contrast to the rest of the world.."

"It was the security of being able to lie in bed and be safe and warm in your little bubble with all that stuff around you... it was completely my own, completely claimed by me...."

This can be seen as a manifestation of the desire for a clear distinction of public and private, both

"spread out" and "claimed turf". When asked to describe his ideal house, it came out as:

"...lots of land and separated houses, like bedrooms separated from the main living place, fields, gardens, wild stuff around the houses, separated houses, I mean not just houses separated from houses but bedrooms separated from houses, and bathrooms separated from bedrooms, I mean really, just spread out.

Finally, the "most important place to me in the whole world" doesn't claim such architectural distinction. The place with the most meaning to M2 has very little architectural distinction or definition, but it is bound to him by the blood of heritage and memory.

"...my grandparents bought it, and my mother and her brothers and sisters grew up with that place ever since they were like four years old they were going to this place...its a cottage on a big big big lake...and there's all the stuff that makes a big difference...and theres lots of attachments to those things, memories... That's definitely my favorite place in the whole world.."

"...No, an identical place like it wouldn't do the same things for me if it didn't have the attachments of all my relatives , my grandparents, ...when I go there I feel like I'm basiclly with my grandparents, that they're around, and that there watching so that there is a real connection with my past there that does not exist anywhere else. You can have an identical house in an identical situation, but if it didn't have those memories and connections it would just be a nice house near the lake with a nice lawn."





analysis of interview f3:

The sense of community is the overwhelming impression that I was left with as defining home for this person. Almost all discussion of home were discussed in relationship to the other persons around. Most answers were plural, I sometimes felt I was interviewing a group.

"The neighborhood is very like a home"

There was a sense of the social investment this person had made was rewarded with a knowledge of the place, which was much more than mere dwelling. In this light it was not surprising that this persons ideal home was where they were presently living.

"..we had a nephew who said, "Oh, why don't you come out here? and we said no... We wouldn't know anybody--we might know them, and a few people like that, relatives, or something, but we wouldn't know anybody, and I don't think you can do that, at our ages and be happy. No, I don't think that there's any other place that I could be more contented...I'm very content. We have friends. It's very different,

different world altogether from where we grew up. I'm very content here."

This feeling part of a community is combined with a fierce independence. Home is:

"Having it comfortable. And if you don't feel like getting up today, you don't have to. And you can do as you please...this is my own place...I think that it's just that it's your own, and you get your own habits and all."

Comfort is something which is individually defined, and the most favorite spot is one which is "comfortable and cozy."

analysis of interview m3:

This interview brought up two major themes of home: A place of creature comforts and a place of relatives. The creature comforts of his present living situation were much appreciated:

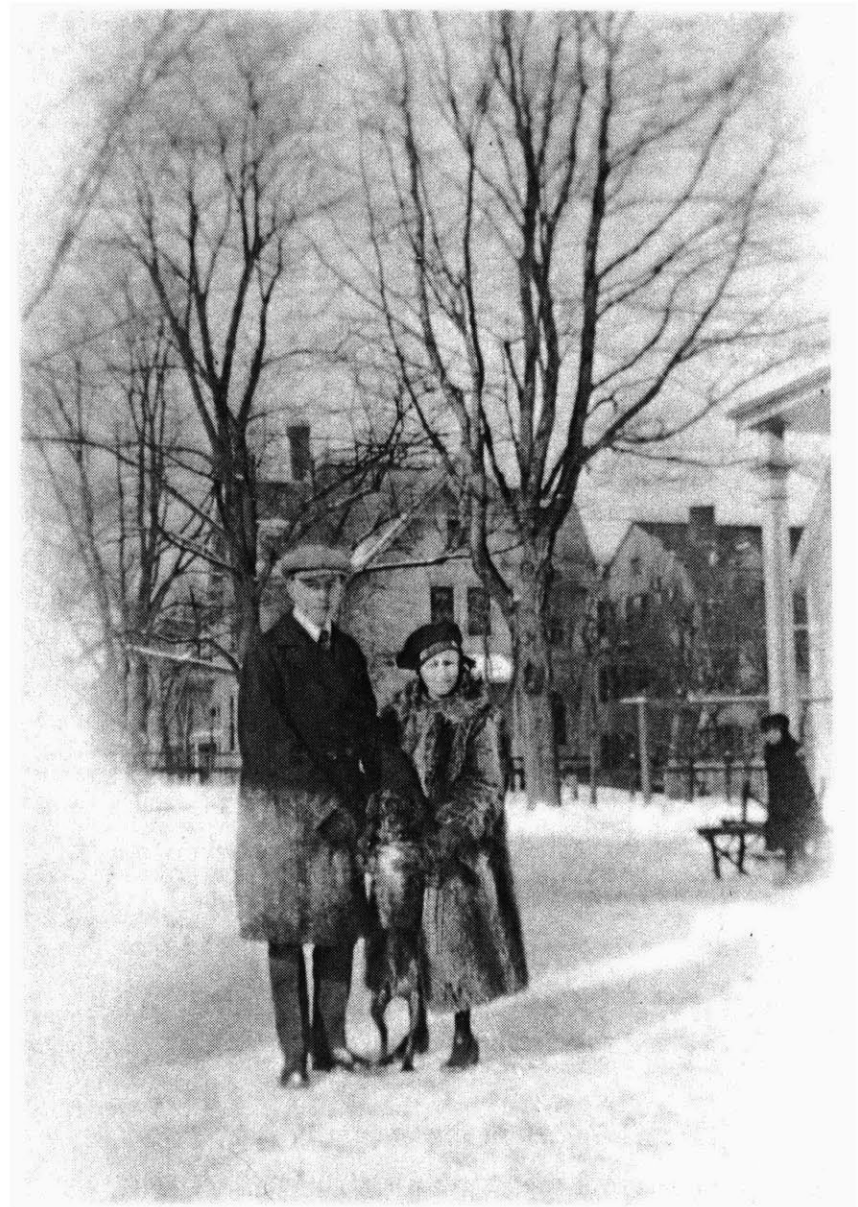

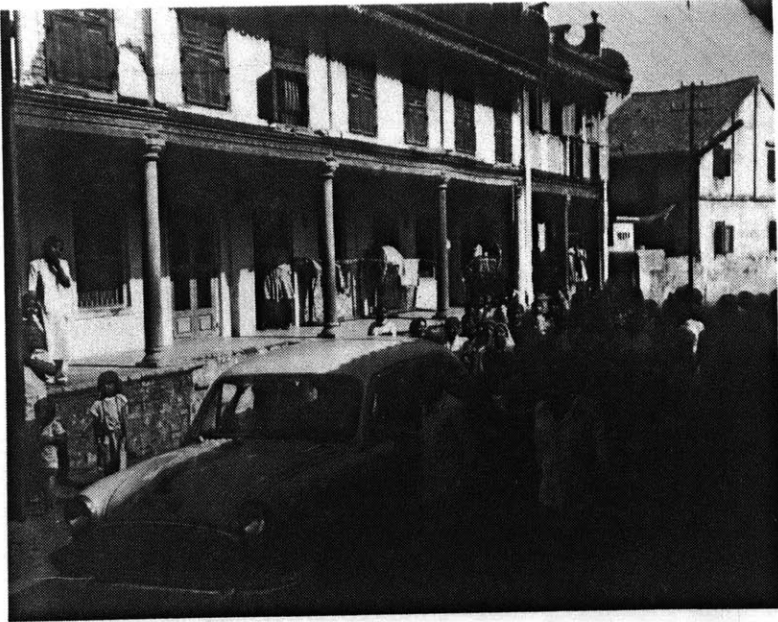

"...It has good hot water, it has good cold water, every kind of utilities, lights, gas, water, etc. and if you have a problem you can just call them and they will come and fix it...(in India) We had facilities like gas, we had to buy our own gas in bottles.

The idea of staying close to the family is very strong, an interdependence born of being "strangers in a strange land".

"Well, since my mother and my parents came here, they've been here three or four years, and my uncle already lived here, so they tried to live here...lots of our family's peoples live in this building, so if I have any problem I can go to my cousin's apartment, or my uncles apartment. It's a nice building...I don't like to live alone. I like to live with relatives and other people."

This once again infers the continuity issue of how to maintain the roots of the past, and the identity created, into the present and less certain future. Perhaps we can transplant our heritage in fresh soil.

Question:"If you could have any place you wanted to live, where would you want to live, and what kind of place would it be?"

"I would like to live in a small home, so quiet up there and all kind of utilities, facilities, and a garden and a back yard. The kind of house I had in India."

Question:"Where would that be?"

"In the United States."

reoccurring themes in the interviews: the final analysis

In none of the interviews was architecture the overriding influence in making a house feel homelike. The apparent influence of architecture was quite subjective. F2 appreciated architecture because it gathered the memories of history, whereas M1 liked the opportunity architecture gave him to physically "build" his world. Buildings gave thermal comfort to M3, and symbolically represented our biological roots to F1.

Some congruence could be found for "activity related" definitions, such as architecturally "cozy" spots. "Cozy" is perhaps defined by being of small physical dimensions. F2 and M2 found small sleeping spaces desirable, F3 liked a "cozy" room, and F1 sometimes retreated to "crawl up under my cowhide and breathe"

The non-architectural issues of domesticity seemed to have more congruence, and constituted the bulk of the conversations. Control over space was mentioned several times as defining a place as home. Almost all the interviewees found home to offer independence, or at least represent it. The proximity of neighbors,

family and friends also constitute a large part of feeling "at home". This degree of connection to "roots" and family offers home as the security of continuity of time and space, and thus the promise of an individual identity.

These seemed to be the strongest feelings about home. These issues have more to do with life experience and position rather than with any physical location. In the final analysis, this idea acknowledges that the physical home is transitional, and the true home is somewhat imaginary, as in "your dreams."

notes

1) Ziesel, John "Focused Interviews" in Inquiry by Design Brooks Cole Publishing Co. 1982 pgs. 137-156



OLD, RUN DOWN MULTI-FAMILY HOUSING UNIT IN URBAN AMERICA

A PHYSICAL CUE

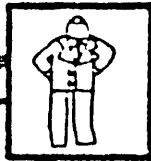

SEEN BY DIFFERENT PEOPLE

THE MANAGEMENT DOESN'T CARE ABOUT THE OCCUPANTS. RATS ARE PROBABLY ALL OVER. IT LOOKS LIKE A CRUMMY PLACE TO LIVE!

INTERPRETED THE SAME BUT...

THE OCCUPANTS ARE OK PEOPLE. THEY JUST NEVER GOT A BREAK. IT'S NOT THEIR FAULT SOCIETY DUMPS ON 'EM

THE OCCUPANTS ARE OBVIOUSLY STUPID, LAZY PEOPLE WHO'VE NEVER WORKED A DAY IN THEIR LIFE AND DON'T CARE.

WITH DIFFERENT MEANING

ch ch ch ch changes

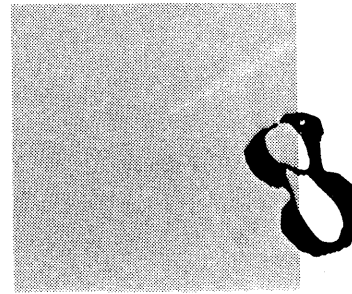

Upon examining dwelling from the aspects of design, case studies, interviews, and academic research, it is apparent that the inescapable congruence in these explorations is the idea that the built environment is but a subset in the many definitions of dwelling. Dwelling is influenced by cultural meanings and values, as well as location in time and space. Acknowledging that architecture is but one of this number of influences, it remains the one that we have a specific interest and can have an active influence in. In light of the forgoing, we see the built environment reflects many of the manifold influences of culture. In this chapter, the dynamic influences of time and values are examined.

values

Perhaps Riegl was one of the first people to explicitly place values in the path between the person and the perceived. By doing so, a completely new relativistic interpretation of the environment was created. Riegl identified a range of values,

which individually or in combination would influence the meaning that a given object would have for a particular audience.

In trying to understand the influence of values, I have found it helpful to organize them in relationship to their rational or sensory / intuitive appeal. For example, an object from antiquity may be recognized as such, but perceived differently by two persons. One may recognize its historical value as an object informing us about the past and its origins, and the other may appreciate the object strictly for what Riegl would describe as its *age value*, the sense of wonder emerging from the feeling that the object embodies some "frozen Past." Similarly, an object might be considered for strictly its utilitarian aspect, or only for its aesthetic value. The manner in which personal values filter and imbue meanings is highly idiosyncratic, and it is therefore easier to describe our own values than to assure a similar interpretation of our intended meaning.

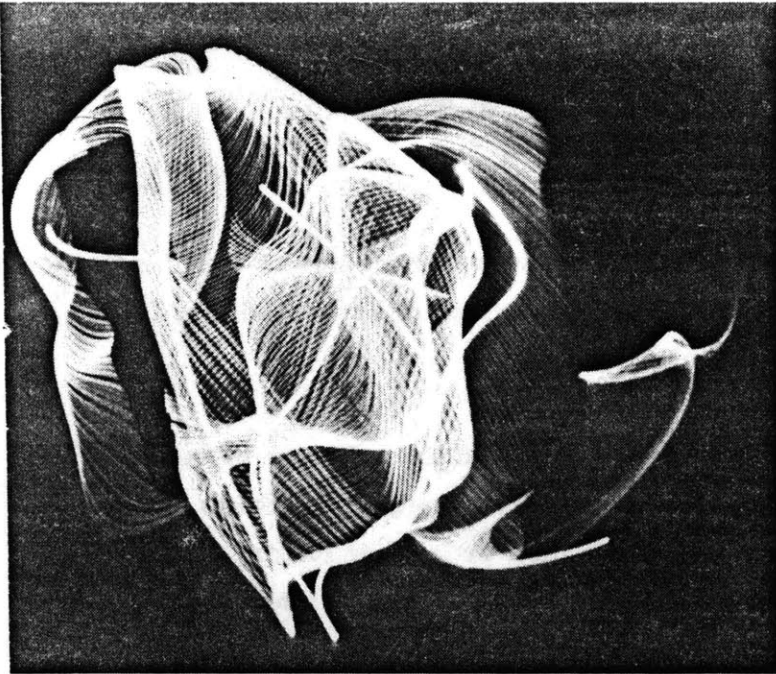

time

time

Time may be considered a filter of our interpretation of our environment as well as a creator of our interpretations. As a filter, time colors our interpretation of place. Although different places are at the same chronological time, time is virtually different. Different speeds of living, degree of cultural/industrial/economic development, the different directions of cultural development, etc. increases the distance of familiarity, and hence the relative location in "time". This relativity insures that the little town that time forgot will always exist.

Relative location in time can by itself create a value for an object, such as age or newness value. Many places are valued for their "quaintness" or "modernity". The relative nature of time is a flux which allows movement forward and backward, as well as "defying" time by freezing it into physical objective reality.

memory

As a creator of meaning, time reaches into the collective memory and can embody a given place with a meaning from the past. Absolute (chronological) time insures a dynamic relationship between the object and its meaning.

The creation of symbolic monuments occur when past events are recalled by an object. When this happens, the object then acquires a meaning associated with the memory. In this way, objects or things not connected with events act as catalysts by an association which is made between objects and events . The object thereby acquires the associated meaning and importance.

This is the symbolic significance of the past. When we return to a childhood home, what are we looking for? What future part of our psyche lays dormant, waiting to be unlocked by a memory? Our memories are not just the past. The stories and myths we understand help guide our present, informing our understanding of dwelling. Over time our memories integrate us with our surroundings, making our dwelling a tightly fitting an extension of ourselves.

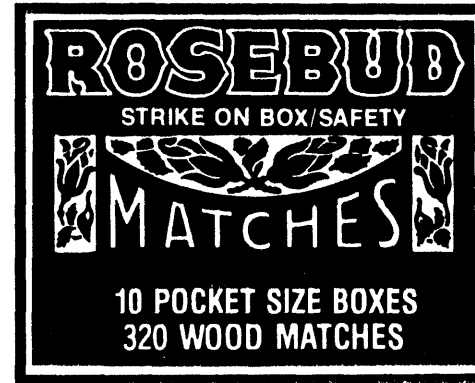

"In Romain Rolland's novel Colas Breugnon , when after a life of trials, the leading character is offered a larger more convenient house, he refuses it as being a garment that would not fit him. " Either it would hang on me too loosely" he says,"or I should make it burst at the seams". (1)

Dwelling "becoming" by act

The implication of dwelling as an act is that it occurs over time. In this manner it is constantly in transition.

In a typical suburban development, (say Levittown) all the buildings begin initially looking virtually the same. As they are purchased and inhabited, they slowly change and become personalized reflections of the inhabitant. Much of this change can be considered cosmetic, or activity oriented as physical change in the dwelling.

Equally, or perhaps more important, are the metaphysical gatherings that occur over time. Over time, places gather layers of meanings by use and adaptation until the web of meanings is like some twisted chicken and egg story. Is it the place that is significant, or the events that have occurred there?

The dwelling is not only a repository of self, but also of spirit. The experiences in a specific location imbues the materials with a metaphysical component which grows over time.

On a personal level I believe this is self evident as we recognize the inordinate strength the places of our childhood have for us. On a collective level, this generation of place spirit over time also occurs. A certain aspect of it is academic, as we culturally understand the significance of the location where Washington crossed the Delaware, or the bloody ground at Bitburg.

The spirit of a place may also be associatively (symbolically) initiated to begin the gathering of place experience. The Vietnam War Memorial in Washington D.C. is a static force which daily receives the anguish of visiting citizens. This simple form directly addresses an emotional need; this rock uncorks peoples emotions. In 1000 years, when the memory of the Vietnam War is dimmed by history's currency, I dare say that this memorial will continue to command a presence generated by the emotion spent there, much as the Parthenon does today. (2)

future

The object can be the physical incarnation of ideas (feelings/knowledge). We often "encode" lessons into the built environment to allow the ideas to be understood by future persons encountering the object. This dwelling concept is therefore primarily concerned with the *future* dimension of time and the successful transition of ideas into it. These interventions are absolutely intentional and may happen in order to transfer knowledge to persons who are presently alive but have not yet encountered the idea, or to generations in the future, or into the unforeseeable future (Recall the plaque NASA sent into outer space) In dwellings, this is perhaps epitomised by the Eisenman attitude that someone from outer space should be able to study and eventually understand all the ideas built into a dwelling.

ch ch ch ch

Perhaps the greatest gift time affords our dwelling is not the past, present, or future, but rather the inevitability of change. Meanings change, forms change..perhaps change itself changes. In the I Ching, the chinese concept of change fills the category of time with content. As such, the opposite of change is not cessation of movement, but regression.

The opposite of change is also movement. The placidity of constant change is evolution, the constant realignment of influences. Defining dwelling takes a moment in time, and in this way adds to our understanding.

notes

Bachelard, Gaston The Poetics of Space Beacon. 1969 ,pg. 102

Bloomer and Moore Body, Memory, and Architecture. Yale University Press, 1977, pg. 110

They kept going up. Ancient granite steps, wide and worn. Leather sandals slapping rock echoed in time. Pausing to catch her breath, she looked back and saw the world's light as if through a keyhole, framed by the ascending vault. Looking forward, the view was similar. A spot of light 300 steps above her. Climbing was exhausting, but the chill of the cool granite raised goosebumps on her arms, and propelled her up to the light.

Emerging was a shock. Sunlight so bright she squint. The vastness of the space made her feel very small and light, like a speck of dust disconnected from the ground. Her skin felt the heat penetrating.

The heat was her friend, and she welcomed its aggressiveness, it was vitalizing, and like a drug, relaxing.

She was in a huge elliptical bowl, about one third of the way up from the bottom. A decaying stadium of sorts. Her horizon was the uppermost row of bleachers; above was sky, below was granite. A hundred odd people milled about, yet this place was empty. She was alone with the granite, sun, and heat.

The heat was everywhere. The rock radiated as if to compete with the intense sunlight. Moisture began to bead under arm. She steadied herself, leaned on a low wall, and surveyed.

A few ant-like people slowly crept around the other side. Nearby, a child whined to its guardian. Her gaze inevitably rested below on the center of this bowl, where a maze of walls replaced the expected sportsfield.

The walls challenged her rationality, their seemingly chaotic arrangement. What would it be like to run through that maze, she wondered.

The heat reached her bones, she closed her eyes and saw dust, kicked by galloping horses, and the spray of their pungent sweat. Flaring nostrils disappeared, and the immediacy of the moment brought the crowd to its feet, yelling, the naked glory of mortality thrilled without parallel, a deafening wall of sound, sight obscured by reckless abandon, the fear of being crushed by the crowd balanced by the exhilaration of being there..

"Come on, let's go on" he said and took her hand. She looked at him wildly, as if he were a stranger. Goosebumps relaxed, as she again felt the seductive heat of the day.





Conclusion

Dwelling in a dwelling makes a dwelling a dwelling. Redundancy is not the issue here, but rather the self referential nature of environmental meaning.

Dwelling as a noun connotes an abode or habitation. As a verb, to dwell connotes the act of living in a location. The combination of the act with the location results in a third condition, that meaningful relationship with the environment that we consider home.

Definitions of dwelling are as varied as the people that espouse them. As an existential mode of being in the world, dwelling is an act, dependent on our ability to find meaning in our environment. The physical manifestations of dwelling (buildings) must provide this meaning either through their material, their form, or through symbolic association. Analysis of the interviews reveal the predominance of *associational symbolic meanings* in creating homelike qualities of dwelling. Home is variously seen as symbolizing community, heritage or security, home was

a symbol of self and / or of an idealized dream. Symbolic associations were seen to carry a multifarious range of meanings; hence when designing for symbolic associations the disjuncture between designer and user was most apparent. For who is the resulting design meaningful? For the architect who designed the house or for the person who lives in it?

Because of the difficulty of predicting the associative symbolic value of a given item for a specific person (especially over time!) it is most useful for architects to work directly with the physical form. The meanings forms generate through their use (activity oriented definitions) are predictable and widely understood by the layperson. Conversely, if the activity oriented meanings are ignored, the result may be a building who's very inhabitability restricts it from becoming homelike. In the case studies, when the primary activity oriented definitions are satisfied, they provide a positive basis which allows for further *user defined symbolic associations*. For example, the symbolic

meaning of hearth may or may not be indicated by various cues. In the Usonian dwellings the fireplace, living room and kitchen are physically adjacent, affecting the perceived nature of the hearth by its direct relationship to the user's activities.

I find activity related design criteria to be sound for developing a dwelling sensitive to a user's physical needs, but basically unrelated to providing for *specific* symbolic association. (it is neither good or bad, just unrelated) However, by focusing on activity related meanings, the design was left relatively open to *user defined* symbolic associations. As stated above, symbolic associations are those that the users seem to most strongly associate with making a house seem homelike. In the design transformation these symbolic associations were shown once again to be disassociated with the physical form; meaningful symbolic associations must then be generated by the user.

Because symbolic associations grow and change over time, the inevitable conclusion of this thesis is a return to the original premise: Dwelling in a dwelling makes a dwelling a dwelling (dwelling is dependent on dwelling). The user must build their own associative meanings in a given habitat over time. Architecture can not ensure that a person will enjoy a house and have pleasant associations, but by providing encouraging activity based definitions, architecture can provide the fertile ground for the growth of a house into a home. It is only through inhabitation that a physical form can accrue the symbolic meanings that make a house a home. In this manner we understand the proportionate role of architecture in the definition of dwelling.

Massachusetts Institute Of Technology
Cambridge, Massachusetts 02139

Library: *Roche 7-238* Date: *2/4/86*

The material noted below is: () needed for reserve.

Please return it by *2/9/86* requested by another user.

If not returned, a fine of \$1.00 per day per item will accrue,
in addition to any overdue fines already accumulated.

NA 7207 B37 1982

Barber, G.F.

George F. Barber's Cottage souvenir
#2

Lib-9-76

.....
Librarian

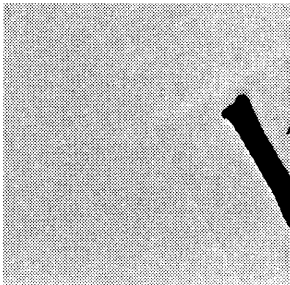

Bibliography

Norberg-Shultz, Christian

Intentions in Architecture. Allen and Unwin, 1963

Genius Loci: Towards a phenomenology of place. Rizzoli, 1980

The concept of Dwelling. Rizzoli, 1985

Kennedy, Robert Woods

The House and the Art of its Design. Reinhold, NY, 1953

Wright, Frank Lloyd

The Natural House. Horizon Press, 1954

Sergeant, John

Frank Lloyd Wright's Usonian Houses. Whitney, 1976

Pragnell, Peter

Mackintosh Graffiti. Spazio & Societa, #15,16, 1981

Ville Savoye. Spazio & Societa, #15,16, 1981

Bowen, Judy

The House. M.Arch Thesis, MIT, 1976

Czajka, James Vincent

Architecture and Awareness of Self. M.Arch Thesis, MIT, 1975

Wolfe, Tom

From Bauhaus to our House. McGraw Hill, 1981

Alexander, Christopher

A Pattern Language. Oxford University Press, 1967

Lynch, Kevin

The Image of the City. MIT Press, 1960

- Hofstadter, Douglas R.
Godel, Escher, Bach. Vintage books, 1980
- Berger, John
About Looking. Pantheon, 1980
- Bachelard, Gaston
The Poetics of Space. Beacon, 1969
- Heidegger, Martin
Basic Writings. Harper and Row, 1977
- Jenks and Barid, ed.
Meaning in Architecture. Design Yearbook LTD., 1969
- Kepes, Gyorgy
The New Landscape. Paul Theobald and Co., 1956
Structure and Society. George Braziller, 1965
Language of Vision. Paul Theobald, 1944
- Neutra, Richard
Survival through Design. Oxford University Press, 1954
Mystery and Realities of the Site. Morgan & Morgan, 1951
- Moore, Charles et. all
The Place of Houses. Holt, Reinhart and Winston, 1974
- Ruskin, John
The Stones of Venice. DaCapo Press, Inc., 1960
- Calvino, Italo
Invisible Cities. Harcourt Brace Jovanovich, 1974
The Baron in the Trees. Random House, 1959
The Watcher and other Stories. Harcourt Brace Jovanovich, 1984
Marcovoaldo. Harcourt Brace Jovanovich, 1983
The Path to The Nest of Spiders. Ecco Press, NY, 1976
The Castle of Crossed Destinies. Harcourt Brace Jovanovich, 1976
Difficult Loves. Harcourt Brace Jovanovich, 1974
Mr. Palomar. Harcourt Brace Jovanovich, 1985

- Heschong, Lisa
Thermal Delight in Architecture. MIT Press, 1984
- Rappoport, Amos
House, Form, and Culture. Prentice Hall Inc.,NJ, 1969
The Meaning of the Built Environment. Sage Publications, 1982
- Kidder, Tracy
House. Houghton Mifflin Company, Boston, 1983
- MacLeod and Pick
Perception: Essays in honor of James J. Gibson. Cornell University Press, 1974
- Gibson, James J.
The Perception of the Visual World. Houghton Mifflin Company, Boston, 1950
- Todorov, Tzvetan
Mikhail Bakhtin: The Dialogical Principle. University of Minnesota Press,
Minneapolis, 1984
- Hertzberger, Herman, et. all
Aldo van Eyck. Stichting Wonen, Amsterdam, 1982
- Rudofsky, Bernard
Behind the Picture Window. Oxford University Press, NY, 1955
- Gans, Herbert J.
The Levittowners. Pantheon Books, NY, 1967
- Handlin, David P.
The American Home. Little, Brown and Company, Boston, 1979
- Brown, Theodore M.
The Work of G.Rietveld, Architect. MIT Press, 1968
- Walker, Lester
American Shelter. Overlook Press, 1981

- Schuler, Stanley
_____ The Cape Cod House. Schiffer Publishing Company LTD, 1982
- Davis, Sam
_____ The Form of Housing. Van Nostrand Reinhold, 1977
- Wilhelm, Hellmut
_____ Change. Harper and Row, 1960
- Wright, Gwendolyn
_____ Building the Dream MIT Press, 1983
- Lam, William M.C.
_____ Perception and Lighting as Formgivers for Architecture. McGraw Hill, 1977
- Comstock, William
_____ Specimen Book of One Hundred Architectural Designs. Bicknell and Comstock, NY,
1880
- Robinson, Albert G.
_____ Old New England Houses. Weathervane Books, 1976
- Bloomer and Moore
_____ Body, Memory, and Architecture. Yale University Press, 1977
- Mattill, John
_____ "Clamping a Lid on Homeowning". Technology Review, Feb/March 1986. pg 80
- Krim, Arthur J.
_____ Triple Deckers of Dorchester: An Architectural Historical Survey. Boston
Redevelopment Authority, 1977
- Boudon, Philippe
_____ Lived-in Architecture. MIT Press, 1979

appendix

excerpts from interview f1: an increasingly affluent young woman

What makes a place seem homelike to you?

Well, it has to feel kind of lived in somehow. There's kind of, sort of, lots of homes...what makes a home a home, that's hard because at times I think of a home as a real comfy cozy place, you know, that has lots of special things in it that feels real lived in, but then at times I think, God, I'm really sick of this, I really want to get rid of everything I own, I want to live in a big white room that's more like industrial, you know? And have just really high techy stuff,

uncluttered...

and uncluttered, so that's like the opposite of what my upbringing of, or what I was kind of used to what a home, my idea what a home would be. You know, like family room, and nourishing, and you know like the kitchen always baking, that sort of thing. So the basis is that it has to be usable, it has to be workable for whatever you're doing in it, like a kitchen, say...

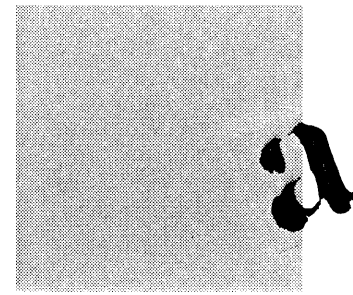

So sort of functional

It has to be real functional, like all your interests, whatever interests you have, well, obviously you know, if you're a big party giver, then you want to have a special room for parties and a special kitchen, that can accomodate lots of cooking and all that.

The home reflects an aspect of your lifestyle. how long have you lived here?

Ten years.

Do you like it here, or...

Well, I guess there's a big difference between owning something and renting. You know, it'd be more of a home if I owned it. Basically the only reason I'm staying here is because it's convenient and I have such a good deal. And you know, it's not torture or anything, it's a perfectly nice place, but to be in one place for so long is you know I'd like to purge, get rid of a lot of

stuff and start, you know have some new surroundings for new stimulation, not still the same shit. So that's important, you know it's important to be able to change, to have the kind of space in your home that would allow for, you know if I did own a home, that would allow for change, that is constant now. Like I would hate to move into a house that was permanently well, there could be, well, like this place, for example, it's kind of impossible it's pretty hard, you know you could change around this place,

knock down walls...

knock down walls, and all that, you could, but I don't own it, so I'm not going to do that...

Right. so that seems like a big part of what your dissatisfaction with this place is, is that you don't have that power over it to change things, sort of grow into it more and you've maybe done as much growing into it as...

as I can, yeah.

and now you need to change.

Yeah I need to change space, you know, layout,

You mean layout in terms of physical layout of the apartment?

Yeah.

Right now i guess this is rooms off a hallway. what would you rather it be like?

I'd rather live in a, well, it depends, I mean will I talk about my dream house, or...or are we talking about a space. I mean if I wanted to move, buy something in the city and stay here, I would want to buy a loft type space, which would be one big room where you could basically make your decisions about how you want to split it up, and you know this is constricting in a sense... You see people who live in lofts want to live in apartments. But I don't know, having one big room so everything is more kind of centralized.

Uh huh, so everything's out there in the space, you're saying?

Yeah, like the kitchen being a full kitchen, but kind of like not having a wall separating it from the dining room.

So sort of that openness...

yeah, more openness, and I mean you could always change that around, if you wanted to, if you at least just had a big space. And a house is a different story.

The kitchen is important ?

You know the kitchen seems to be the center,... Every room has its function. You know, the front room, the living room, which is cozy, but I think I find I spend most of my time in the kitchen creating, doing things making things,

Even when you're here alone?

Yeah, I don't really crawl up into a certain corner or area. I like having different rooms for different purposes.

And the kitchen is the room for living?

Well the kitchen, you're like nourishing, and enriching and creating..

But after that when you're thinking about relaxing and

not your nourishing sort of function, is there a place in the house you sort of like to sit down and space out in, look out the windows...

I relax in the kitchen.

You space out in the kitchen?

Yes. Or if I'm really tired then I'll crawl up under my cowhide. And breathe.

That's in the livingroom?

Yeah. So that's cozy and comforting.

This is pretty internal, it's insideish, it's not looking out windows,

No, yeah that's the thing, I like a lot of windows, skylights, verandas. It is a real cave.

And is that detriment?

Well, I like caves, but I think you should have the option of not living in one too. You know there are certain periods of your life when you need to be in a

cave. But you also need to get out of your cave. And be in the sun.

What about that porch, do you use that some in the summer?

Yeah, I use it a lot in the summer, it's real nice because it's an extra room and there are lots of plants out there and I hang out there a lot in the summer.

Your optional outdoors.

Yeah. I'm usually working on something. I don't usually like blob out, I like to keep busy. Chasing birds around the house and visa versa

So what would you say the worst aspect of this place is? what do you dislike about it the most?

Well, I dislike that I can't change it enough to make it feel different. It's just the same, as much as I redecorate, and I redecorate a lot.

It's different from last time I was here.

Yeah it's always changing, you know, it's like my

clothes, I never.. If I'm not hanging out by myself, you know I'll change my clothes a million times a day, it's like everybody's in constant it's constantly changing. So kind of like your house has to be suited to that. Or be able to, and it's not really suited to that too much. Everything like has its place and it just doesn't seem worth it to you know I COULD change the living room to here, but you know, it's set up. That's the dining room this is the kitchen, that's the bedroom. It's like you moved around in your bedroom, but you stayed in your bedroom.

There's only so much you can do.

Yeah, and there's only so many ways you can move in a small space.

So why did you move here into this apartment, what was the story to that...?

Well, the same guy, that got me my job, he mentioned that a friend of his had an apartment, and was looking for a place here in Cambridge because I was going to get this job, and came up here and someone else was interested in it, and I said I WANT IT, I mean it's fine it's perfect, there's no problem with it, and I got it. It was like referred from a friend.

Uh huh, so it was convenient.

Yeah, it was convenient, and it was right near where I had to be, and I couldn't be in Boston, which is where I wanted to originally move to, I like the area, I like the trees around and stuff. Kind of pretty.

So what was the nicest place that you've lived?

Well, I lived in a great place and location in a Ubange hut in Eilat, in Israel, right on the water on the Red Sea. It was great, it was a little community of little huts. Grass huts. With cement walls and little chameleons climbing on the walls. It was great. It was perfect for what it was, it was shelter. You know you could conceivably do your entertaining outside, or something like that, you know so I could always...yeah, again, well it depends where you are. It would be nice to have shelter and then have lots of outdoor space like in Mexico they must have some you know in warmer climates they have great places, haciendas, most of the entertaining is done probably outside, you know screened in or something.

What made that really nice was the location of it or the hut itself was really cute, or...

The location was great, and it was sufficient for where it was, you know like you didn't need a house with central air conditioning.

So there was a whole community of little huts.

Yeah.

And you would go from hut to hut like room to room?

No, we just had one hut. But I just loved the grass, I just loved the earthiness, the primitive value of the shelter, that was great. I loved that, I'd love to live in an old grass thatch well, I mean even in England don't they have a lot of old country homes that are made out of stone and some other organic material for the roof?

Wood timbers and sometimes either clay or slate tiles, and thatch roofs.

Clay yeah, real primitive shelter, oh yeah, I love that, I think the more primitive the better.

Like they just sort of grew out of the earth?

Yeah, cause we're primitive. Why not live in a primitive home? That's homey, that's what I envision as being real homey. Fireplace, and smoke coming out of the chimney, I mean, a castle could be homey, but, it depends, you could go any way, you know? I think any of the categories...

Right, you can always find a home if you associate with that class,

Yeah.

What about the place you grew up? what did that look like, where was it?

It was kind of barren. Long Island. It was suburbs, suburbia. We lived there, I lived there pretty much all my life. When I grew up. It was like a nice little community, with little homes one after another, you played in the street, school was right down the road...

Really almost like a popular t.v. sitcom?

Yeah, pretty much, a little nicer than that. It wasn't like low class. It was like middle class, upper middle class.

Two story houses?

Yeah.

You lived there, what, fifteen years, seventeen years something like that?

Yeah, seventeen, eighteen years. I lived in Chicago for a while. That wasn't any place to..

Uh huh, that wasn't with your family.

No.

What about the house you grew up in. did it have any particular memories or feelings associated with it? what was the favorite part of the house?

Oh my favorite part about the house was that the kids had the upstairs. And before my parents knocked the wall down there was like, when you walked up the stairs there was a door wall so it was like a private apartment, it was all paneled with cedar, and we had our own bedrooms up there and a bathroom, so three bedrooms and a bathroom up there, so it was real neat. I liked that, it was fun. Faith was downstairs, ha ha.

So you had your own little apartment or house within that...

Yeah, it was real kind of cozy. I liked that place. But then, they changed it, and it was gross.

And so your parents have moved from that house now?

Yeah. They've moved.

And have you ever gone back and visited the house you grew up in?

I went back a couple years after we sold it, just passed by real depressing. It was real depressing, you know, like getting rid of it, it was real roots, childhood stuff. We went back, but there's kind of no point to even go back and look at it, you just kind of go back and say "this is where I grew up", the house didn't hold the same, it didn't have the same aura at all, you know, new people moved in, and that's it, it's totally different, it's not really a house any more. The house is imaginary.

We kind of approached this subject at another point in this conversation, that if you, to make an ideal home,

now what do you think it would be if you could just sort of click your heels, and go some place? where would it be, and what would it...

You see I'm facing those issues all the time. (laughter) I've never quite figured it out. I think it should be near the ocean, and it would have to be a lot of out of door access that was functional. Like a big screened in, or not screened in, so you could hang out outside a lot, do things outside.

So the house should actually go out..

Tree house yeah. And I'd want it built out of materials that were primitive materials, as primitive as you can get. And pretty basic.

So you feel like you could do without a lot of modern conveniences.

Well, I'd bring in the modern conveniences - God forbid my Cuisinart can't come along! Well I think it's a combination of primitivism and technology. I'm not against technology, it's an incorporation of the two, cause I think that's really important. In primitivism, I'm merely saying that it's part of our it's something

we should never lose touch of, which people do. You know, we forget that we're human, and so that's my part of that. And the technological part is like this IS, we are living in 1986, and we might as well take advantage of that, also. It's kind of like the best of both worlds, you know, everything.

So even though we're living in 1986, we still have human biological roots that are of earth and that sort of has to be reflected.

Yeah, definitely. It's sort of like my work, which is a lot of things I have around me which is kind of reinforcing that yes, we are human, let's not forget and let's not take for granted that we're alive, let's try to keep our values in the right places.

This description you have of home is very poetic.

Kind of, yeah. I don't know, it's hard, cause I don't really have a dreamhouse because I don't if I had something to aspire towards, then I think that I'd be aspiring towards it, right? I'd be doing it if I had a goal. Of a perfect house, but I don't I haven't like that. I mean down to the last detail, I haven't sat down and planned my dreamhouse, so when it's time I can

have it built. But it's kind of like what's the use of sitting down and planning my dreamhouse when I can't build it. But I have an idea, it's not real clear, I could sit down it'd take a couple months to figure out what I want in it, what I want it to be. But a picture of it... It depends also where it is, dreamhouse.

Porsche, where you want to live? Oh, we have to have lots of birdies in the back yard. Big aviary. An animal farm would be great. I was thinking of moving to South America and having a coffee plantation and a bird breeding area. Bird breeding business. So you know, real indoor outdoor conveniences, I don't want to rush to the outhouse or anything. Still the primitive look on the outside, because cosmetics are real important to me. And fairly primitive on the inside too, but still nice, you'd have a good sound system, and high tech, but just like the two opposites sort of.

It's an interesting sort of blend of the lived in and the anonymous...

Yeah, it's roots and the era that you're living in. so you kind of have to combine all that, that's like a big project, wouldn't that be great? It'd be so great to do that. Kind of a rich man, a rich husband, he'd say "Okay, honey, let's furnish the house" No problem.

excerpts from interview m1 - homeless man 1-21-86

What I'm doing is I'm trying to come up with different ideas about what makes a place seem like home to someone, and so if I was going to say that to you, what makes you consider a place home-like? What do you think of?

Well, I bought three separate places in Bridgewater, bought them cheap, and I went through them and I improved them, all the systems, plumbing, electrical, etc., and then when I improved them to the point where I felt I had something good, then I would sell them and buy another cheap place. And then run the same thing through. Home, home is a...well, home is children. That's what I would say home is. I don't know, maybe I'm wrong--home is children.

So, did your children live with you in all three of those places?

Oh yeah.

Where do you live now, pretty much?

Unfortunately, I'm living here on the streets--not the streets, no, because I think of somebody living on the streets as somebody that doesn't do anything--I am doing something, so therefore I feel, in this sense that I am not living on the streets, I'm working on my PhD at Harvard. But, I'm living in a shelter. But at the moment I've got a real good lead in Bridgewater on a apartment, very small apartment; but I'm working on that because I'm getting very tired of living this particular way. It's not good for you. I've had, unfortunately, quite a few medical problems. And I want to get into a place where at least I know I won't have to worry about those sort of things. I've had cellulitous in my leg, I've had skin grafts, I've had three hernia operations, I've had the same operation the President had, took out a section of the colon, I could go on, I've spent so much time over the last couple years in the hospital, that I'm so sick and tired of being in the hospitals that I could screech. But I know, it's necessary, so I go through with it.

How long have you been without a home?

Without a home of my own, oh, maybe close to, over

three years.

Three years? Three years you've been looking for a place, then.

Oh, I've been living here, there, anywhere.

And why is that, what brought you to that?

Through separation, my wife.

Of the places you've lived with your wife, what was the nicest one of those three houses?

We had a--she still has it, she wants a divorce, so she can get the house. I won't give her a divorce, because I want to keep my equity in the house, because it's in my name--well, it's in mine and hers as well. So I won't give her a divorce because I don't want to give her the equity I have in the house. I took the house, I bought it for \$7500.00, and it's probably worth ten times that now, for what I did, all the improvements.

This is in Bridgewater?

Yeah, it's in Bridgewater.

Do you ever go back there?

Oh, yeah. As a matter of fact there's a good chance we might get back together again I don't know, Thanksgiving was beautiful, Christmas was also beautiful,

So you go there sometimes for holidays?

Oh yeah.

So if I was going to ask you a place you considered home, that would be it?

Oh, sure--I made that place.

What does it look like, this house?

Well it's an old Cape Cod cottage, built in 1790, it's a beautiful old house, actually historical landmark, and I made the whole house over. Simply because I enjoy working with tools, so I made the place over. Like I said it's probably worth ten times what I bought it for.

Sure. So do you think that's the best place you've

lived, this last one? Do you have other places from your childhood that you have a stronger memory about, happiest times?

No, yes, maybe.

Ha, Ha, that covers your bases.

No, the family home was originally from South Medford and then West Medford. And the house when (my mother was the last survivor) was left, it was left to my sister. Her condition of the will was that there would always be a room there for me if I wanted it, and then when she died it would go to me. It's a lovely house, it's a beautiful house, but I don't have that much fond memories of it, a little bit, not that much.

Nothing particularly special.

No. It was more special for me to, for example, you take the last one I was telling you about, rebuilding a house and especially with my own hands--that to me was much more interesting and much more like a home, and the kids loved it because they participated in the rebuilding of the home. The kids are all grown now, I call them kids, that's wrong, you never should do that.

Ah, they'll always be kids though.

They're good youngsters.

So, one more question. if you could click your heels three times or whatever, if you could have your dream house or your dream-- what would your ideal place be like? Would it be that house you were in, or would it be someplace somewhere else, would it be here in this boston area?

Not in Boston, no way. I'd say, very honestly, because I am a writer, I would say I'd love to, well, as a matter of fact if I were starting over again, I would love to be a forester, and I'd have a place in the Green Mountains, or the White Mountains, someplace in the mountains--I've written articles on the Green Mountain National Forest, the White Mountain National Forest, the Roosevelt National Forest, in Colorado, I wrote about seven, eight different articles on the national forests, because--I think of starting over, I'd love to be a forester. That would be my ideal. But, I wrote on it, I'd go spend ten, fourteen days in the forest, the national forest service knew me, they realized I was working for them, writing, the articles were good articles, you know what I mean, positive.

So you'd have a house in the forest somewhere, do you have any idea how your dream-house might look? Would it be like your cape cod, or would it be more something like the forest?

Probably be more like what had in the last one in Bridgewater. An old house that you could work with, and try and make into...I suppose your dream, which you'll never get.. an old house is nice, an old house is not something that is easy to work with. But that doesn't mean it's not good to work with--it's not EASY to work with, but it's not good to work with. I mean, you walk into an old house like was built, well, like I said, 1790, there were two, exactly TWO outlets in that house when I bought it. So when I got through there were at least seventy five different outlets, I'd do a room over, you rip the walls out, you work on the thing, and then you start running the outlets around the room, and that's...I was in the Kiwanis and I was a master electrician in the Kiwanis, was a good friend of mine, and he'd say, do what you want, John, and when you're through let me take a look at it, I'll pass it, because he knew I could handle the electrical aspect of it. Plumbing I hated, but I could handle it, plumbing is a pain in the ass. But things like that, I did that through, the whole house, I added rooms, put a shed

dormer on the back, I did it all myself.

So then rebuilding a place like that would really start to make it into a home again, from just a regular house.

It was part of making it a home, yes. Sure was. And then that's why I say I...umm, that's a good looking broad, she lives up here at the Y, I know her...that's what I said, that you have an old house, we get in there, we had a piston pump--you understand what I mean when I say we had a piston pump?

NO.

Mechanical. So, I got...the water was down there. I got a jet system, that I didn't install myself, I had that installed, I didn't know that much about systems like that, but I had a system installed, a jet system. And, hey, no problem, plenty of water. And good water, I might add. But things like that, as I said, the electrical system, the plumbing, rebuilding the basic structure of the house, I did. So we had to put new sills in, oh, i'd say two thirds new sills. But I enjoyed this work because I was director of treatment at MCI Bridgewater, and throughout the day I'd have to

use my so-called brains, but then I'd come home and I'd want to use my hands, and work with them. And that's why I did all of these different things which I could do, if I didn't know enough about it, I'd find somebody who did, I'd say well now, what do you do? "You do this". All right, okay. That's what I'll do. I enjoyed it. I ran a farm garden-- two acres of potatoes, the rest of the farm garden I ran about an acre and a half, and I loved it because you get out from under this pressure of mental activity all day long, and you get and you got your hands in the dirt, and you felt great.

Well, I certainly hope you find yourself another place to apply yourself to, it seems like you got a lot of energy left in you for that.

Well, what I've got, I say I working on right now is a PhD.

So you said there's a lead on an apartment?

Yeah. (Talks about his PhD)...Can I say one more thing?

Sure

A house is a house...home is where you live...I suppose

you've heard that so many times it isn't even funny. But actually that's what it amounts to because hey,if you get kids, and between my wife and myself, as I've said "well I've had seven kids" well, I didn't have seven kids--she had seven kids--I think something that has to be taken into account, is when you stop and think of what a dwelling means, a house is nothing. A home is where there is a family, love, accomplishment, I can keep going. That's a lot more than a house. A house is nothing.

excerpts from interview f2- a transitory artist

What makes a house homelike to you; what makes a place feel like home?

Lots of things, draperies and such, but of the specific physical things of the house, I like big windows, I like high ceilings, and rooms that are pretty good size.

So, a lot of space then?

Well there doesn't to all have to be a lot of space, but there has to be at least one big open space.

Does that make it seem more home-like or is it just having a variety of spaces, or...

I think a variety of space is important. You can have a space you can go into that is a cozy living sitting area; you can have a space you can go into that you can move about in, and you can have...

So you live at Nexus, now--and how long have you lived there?

About a month and a half.

And you like it there?

Well, I like it there, yes, it needs work, but I like it there.

And what about it is good? You rent there.

Yes, I rent several small spaces there. I'm waiting for the studio.

So you'll have another space.

So I'm going to have another space there. What I like about it, because I'm a painter, is the accessibility of so much that's appropriate for me--to be able to use the machine shop that's downstairs,

It's got a machine shop?

It's got a machine shop, it's got a darkroom, it has a

stat camera, and it has--the light isn't very good--but it also has a working environment that encourages diligence.

There are other people there working?

Yeah, there's a graphic artist that lives upstairs, there's a musician upstairs, there's another guy that's a critic for the Herald, there are people who work in the machine shop downstairs. So there's a real diversity of disciplines.

What's the best spot there? For you.

The best spot there...Well, the problem there is that it's all in flux right now, so the best spot right now is for me to go upstairs to be Keith and Cy and Kay's space which is now a completed area.

So it's more lived in?

Yeah, it's more--it's cleaned up, it's painted, it's--things are arranged nicely. My room, too--I'm very calm in my room.

Your room isn't very big...

My room is tiny. But for a sleeping space, it's just right, I don't mind having a small space for sleeping if I have a place where I can have a dressing room.

Would you prefer a small space like that for sleeping?

I think if it was a little larger it would be all right. It's nice, different. Actually all my bedrooms have been big.

Where you grew up is big?

No, when I grew up, I always shared. For a long time I lived with my brothers in two small rooms. We had a bunk bed and a trundle bed and another bed, so it was quite crowded. And then I lived with my sister, and there were bunk beds there. That was a really tiny room. We had enough room to go in and back out.

So how many people shared the first room?

The first room, there were four of us.

And did you dislike that, was that all right?

It was all right until I started developing, and then

it was inappropriate. But I enjoyed--we had all these games we would play at night, war games, we would pretend we were blown up and we would make all these romping noises, or we'd drink a lot of water before we would go to bed and then we would shake our bellies so that everybody could hear the water--so that way it was the most intimate time I had with my brothers, that's the closest I ever got. But for ever having any personal expression in the room, it wasn't until I got to live with my sister that I got that.

So from there you moved to--

I moved to my sister's room, she had a room by herself for a long time before I moved in with her.

So how long did you live in this house, this first house?

Eight years. Well, when I lived with my grandmother, I lived there for five years--I had a big room by myself. That was wonderful, too.

That was wonderful?

Yeah. It was a room that had nice light, and it was a

big room, and it was mysterious. It had two beds, a bureau and a closet, and the closet was extremely mysterious.

Oh yeah?

Yeah, I wasn't allowed to go in there, so I was--everything lived in that closet.

Was the closet actually off your room?

No, it was part of the room, there was a door--you went up the stairs, and walked in one door, and straight ahead of that, across the living space was another door that was the closet. There was another door that went to the left that went to a big huge play area that was a huge open room. That was my play area, plus storage, plus other things. But I had two twin beds, and I had scratched my name on the bed - and I got in big trouble for that.

So was this closet that you weren't allowed to go into huge?

Well, from my memory it was huge, but probably it was just a normal size closet. It was filled with boxes and

things--I was fascinated with what was in there.

So since then, have you lived in a lot of other places?

Yeah, I've lived in many different places, and of varying sizes, but generally the rooms were pretty large. Living in old houses in Vermont, you tend to have big bedrooms.

So of all these places that you've lived in, which do you feel like you grew up in?

You see it was all different times of my life. There was a time where from one to five I was with my grandmother, which was one period of growing up, and then from five to twelve I was in Arizona, which was two different rooms; and then from fourteen to fifteen

I was with my aunt and uncle, where I shared a room, which was difficult, because it was with my cousin, who I didn't get along with, and then I was on the farm, and I had my own room, so it was all different series of growing, so I could say I grew up all over. I don't consider any one of them the one that I grew up in.

Would you consider any one of them more home-like?

The one with my grandparents.

And was that because you enjoyed it the most?

Because I was the most secure there.

And what did that house look like?

That was a big rambling house that used to be the high school for the town of Candia and then it was the Odd Fellows Hall, and then it was, I think it was Town Hall somewhere in between there, so it was one of those big New England houses that just go on and on. Over the garage was the place that used to have the stage where the Odd Fellows had been, meetings and stuff. I guess I would consider that the one in which I was the most happy, when I was growing up.

And you shared a room in that one?

No, that was my own room.

Did you have special places in there that you liked?

Yeah, there's lots of special places. My room was

special because it was my room. Because it was so big, or it seemed so big to me, and there was lots of places that were--there was the back room that was sort of the playroom, that also had stuff in it. There was a lot of mystery about that house too because it had this feeling of continuity, because other people had lived there, and it had belonged to the family for quite some time, and all the other separate histories that it had been in. I'm really fascinated living in houses that have existed and have--the charm of old houses. The dining room was fascinating to me too because it had this wonderful wallpaper of Venetian boatmen. And there was the pantry that was fascinating too because it was where my grandmother would wash the dishes. It was a pantry that had little shelves and all this wonderful glassware, a little display. That's where she would cook up all her meals, and then she would bring it into the kitchen or the dining room, depending on whether it was a formal or just a family dinner.

Have you been back there?

The last time I went there is when my sister came to visit, but someone else owned the house, so we couldn't get in there. The last time I was there was for my grandfather's funeral.

And you went inside?

That was in the house, yeah. After the funeral they had a dinner, a gathering of whatever was left, because it was the last gathering of the family.

How did it feel going in the house then?

Strange. All of the things that made it my grandmother and grandfather were there. But they were both dead. And it was cold.

Would you feel a desire to go back there again?

For many years I would go there in my mind, and the house would be there, and in fact this last summer I had a real strong desire to go back there and see it. But I didn't go--the last time I went there with my sister, there used to be a big willow tree in the back and these two beautiful cedars on either side of the front porch and of course they had chopped them all down and it was like, life had moved on, and the house was no longer--it still had the same siding on it, there were still things about it that were-- and I was curious to see what they'd done to change it, but at the same time I was kind of dreading it, going in to

see that it was not the same place anymore.

When you have real strong feelings about returning there, or thoughts about that house what kind of image comes to mind? Looking at the kitchen, or the pantry, or the way it looked from the outside, the willow trees, your room?

I think a combination of all of it, it's...the wallpaper in the dining room is something that really strongly holds me, and then there's the den, too--whenever I was sick that's where I would be put, into the den, there was a little daybed in there. I was quite ill when i was little. The heat for the upstairs was from one of those little grates, so it wasn't very warm upstairs, and every winter I'd get sick, so I'd be in the den. I suppose that maybe the kitchen, the dining room, and the living room I would think of when I was there.

Do you think that's sort of the strongest memory that you have? Of places that you've lived that you grew up in? Or is there any particularly good or bad--strong memories that you have?

My childhood is the good memory, and after that comes

the bad memories, of moving in with my mother and living with my aunt and uncle. Which was like, living with my aunt and uncle was like, cold--it was a New England house, but it was everything... They would keep the house warm, but there was a coldness there that was...it was really not a bad house, it had nice woodwork and things like that, there was the atmosphere, there was...but, if I think about it, I think about the farm where I lived for a few years as I was getting out of high school, and I would think of living at my grandparents--that was for GOOD, and for bad, I would think of living at my mother's house and my uncle's house.

What was the farm that you...

The farm was out in Springfield, Vermont, and it was out from the town, and I took care of five children and cleaned the house and cooked, and I worked there from the time I was fourteen till the time I graduated from high school. And basically, high school. And that was a nice, real old house; I had a room up in the front dormer and there was a nice big elm tree outside. And there was a Victorian dresser that had marble in it, and a big mirror, nicely carved and was just a nice quaint old house. The house was set in such a beautiful

surroundings that the combination of being out there in the country. It was one of those houses that had been there for a real long time. It had big wide floorboards, square nails...

Did you know anything about who had lived there before?

It had been in the family.

So now think about where you would like to be--what would that be, if you could click your heels and have the home that you wanted, where would it be, and what would it look like, and what would the climate be like, and how would it be furnished...

Okay, if I could have exactly what I wanted, I would have a house that was in the country, that was close enough so you could get to the city, and it would be an old house--it could be from Federal to a Victorian, anywhere in there, nice big windows, nice rooms, in a setting that was beautiful, and I would furnish it--oh, the way I furnish things is a combination of a lot of different things, I like to use a lot of fabrics, now. But if I had the money, I would invest in antiques. I prefer older things to modern designs. I like--when I see people's houses that are designed in modern, high

tech, whatever, I like them, but I know it's not my style.

You think it's a matter of style of antiques and old houses, you like the style of them, or is it a sense of mystery...

It's the sense of mystery, it's the sense of having continued, it's the being part of that continuity.

If you got a bureau that was just made, but hadn't been-- it didn't have any chips of history of other people having used it, it might not be as important?

No, it wouldn't be, it has to have that sense of having been used.

In terms of the spaces that you would envision this ideal place in the country, near the city, you mentioned that that one farmhouse you lived in had a dormer, some other things, is the landscape as important as the house to you, or inside the house, you like the big open spaces, or small cozy spaces...

Well, for living in New England, and I like to live in

New England, I think that's where I'll always come back to so what you need is beautiful grounds for the summertime, so you can do your gardening, so you can have pleasant surroundings, but for the winter time, you have to be able to be inside, and have cozy rooms and large rooms so that you're not claustrophobic.

So sort of that range.

Uh huh, there needs to be that range. And some of the older Victorian houses--Federal houses are more kind of standard-- a Victorian house has a large space and several small spaces in it. And I like that, you can make a place to get away to, a place to be intimate,...as you live through more winters here you need to be able to internalize. For me I need lots of visual excitement. Because it's so bleak outside, I want to have rich colors.

What about fireplaces. were they important as you were growing up, or...

Until I moved into the farm, I never had a fireplace. My mother got a Franklin stove, just before our family split up. I really like having a wood stove, a cook stove...a fireplace is really nice to have--I like to

be able to sit and look at the fire, but if it's a woodstove or a fireplace, it's not a big deal. I really like having a cookstove.

Well that pretty much sums up my questions, unless I've missed some place that has seemed important to you. Is there any one in particular you can think of?

Well, there are several houses that I lived in in Vermont that I could do a composite of, that I really like. There's this stone house that I lived in and a brick house, and it had, the brick house had a big huge kitchen, and lots of big rooms, and the stone house had some small rooms and fireplaces and a cookstove. And the wide windowsills, I always really liked that. Lots of light, can look out. Lots of the houses I lived in had lots of light, plus lots of wall space so that you can have not only the picture outside, but you can hang a lot of things.

It seems like things that are really embellished somehow, or have the potential of being inhabited in a way that is...

Yeah, my way of living is very much a modified Victorian. A lot of hangings, a lot of paintings, just

little kind of-- rich, rich and--visually rich. Yeah, a lot of texture, I like beautiful fabrics, embroidered fabrics, I like to have paintings, I like to have sculpture,... I might do with plaster casts, if I have to (laughter)

Okay.

excerpts from interview m2 -a student of architecture

What aspects of place make you consider some place a home?

Well let me see, I guess a place where I can stretch out, kinda spread my projects around, or do things, if it's a really small space or if its a really tight space somehow, that you can't get a big mess made, it would be a drag.

A sort of personal space then, that you can do what you want in?

Yeah, and flexible too , 'cause I'm a sort of flexible person. And also, the way it looks is important, I think since I grew up in a house that was surrounded by open space I would feel a little uncomfortable living in a row house kind of a situation, but I have lived in say, like a four story apartment building that was in a row that felt like home just as much as the house I grew up in or any other New Englandy type of house which is what I grew up in. So , a, it has a lot to do with maybe, that house, feeling home there had a lot to

do with the people, it was kinda laid back , we could put our feet up on the furniture,..we didn't have much to work with; so maybe that's why it was so flexible.

The row house?

Yeah.

So where do you live now?

I live in a duplex, it's like two row houses and we have one whole side, three stories..and the nice thing is there's no separation between the kitchen and the living room,though they are both the same size and they are both kinda small so there really is no living room, and the wall that was between them was taken apart and the studs left and there's a spice rack between 'em.

Uh huh

There's a sliding glass door which opens up onto a very small porch and the parking area...It's pretty close to

the street but it's separated by a direction change and a small level change and also there's some grapes and stuff that provide privacy. ..The activities have overlap, like if you're in the kitchen and you're working at the counter you're facing directly towards the people who are in the living room so that you can have a conversation with someone while you're cooking 'cause you're not facing a blank wall, so there are additions to the normal standard way of living.

How long have you lived there?

'Bout a year and a half.

And do you like it?

Yeah, it's a really big household. I guess the biggest drag is that the person that owns the house lives there so we don't really feel like we have free reign over what happens in the house. I think it's really important to feel like you can drive nails in the walls or tear down walls, replace front doors, things like that without having to report to someone.

So if i ask you "whose house is this", how would you answer?

I would probably say that I'm renting it, which implies that it's not mine to do with as I wish. And it is a drag, 'cause if you want to fix something up, the person who did fix it up originally is still there so she's gonna kinda not want it done, 'cause to her it's her home and she doesn't want it changed by some other person.

Right, right

So that's that freedom, to do whatever you want, I mean it's your own space to destroy or not

Right. so, whats the nicest spot where your living?

Well, let's see. My bed is right under (it's a very nice place, not because it's architecturally great, but because there's) a small skylight right over where my head is at night

Huh

so I can see out through the roof and I can see the moon, I can see the stars at night, I can also here the street traffic really well. The benefits of having that experience of lying down and looking up at the stars

every night is just really great. And its not a big skylight, it's not an expensive skylight, and when you stand up you can see the houses across the street, and otherwise you wouldn't be able to see anything because it's right up underneath the roof. I like it as a sleeping chamber because it's really small, and we have this system of closets and shelves which cover three walls, and everything has its place and it's very small and it's not like spread out so its kinda easy to keep clean, even for two people. I don't mind having a really small bedroom, it's much smaller than the HUD minimums for a bedroom for two people (it's like 10'x12' or 10'x14' at the most)

But it's cozy

It's cozy. But downstairs there's this big study room, and the whole first floor is the public part of the house, and so it's well zoned that way, there aren't any bad adjacencies of having a bedroom right off the kitchen where everybody's hanging out and downstairs there's a lot more room so the places where you do want to spread out and live there's plenty of room , and the places where it's just private for sleeping are small and intimate and contained..and higher up.

So whats the worst aspect of the place you're living now?

It's hard to heat.The place also suffers from a lot of neglect and there's no way to really take care of it because of the way its owned and rented, so it's pretty run down, and when things get fixed they get fixed really half-assedly. Which is a drag.

So you've been there about a year and a half, and why did you move here?

The person who owns the house is someone I went to nursery school with, so it's just a fluke sorta thing.

Moving away from where you're living now, what is the nicest place you've lived?

Hmmm..My space at my parents house is this little shack behind the house, like a garage, and it also has a huge skylight in the roof which you can see everything out, the moon, everything. And it's got a little teeny bathroom, and its' set behind the main house by , maybe, 4 or 5 feet away from it, but you half to walk around the house to get in fer breakfast or whatever.

And coming out, you come out into the backyard, and it's really pleasant to walk from the bedroom into the house. It's a nice trip. So that's pretty nice.

I think maybe the nicest place I've ever lived is this commune up in Vermont. Where my bedroom was (we called it the bed shed) it was just big enough for a double bed and there was a three foot space to walk inside the bedroom and get on the bed and room on the floor for a trunk. And there were windows on two sides starting at the level of the bed and up and those two sides were completely windows so you could look out while you were in bed, straight out the windows and look out over these fields. Just incredible space. This rolling hill that went up was a meadow, so it was all grass, and then in the winter it was snow lay on it and it was really smooth and lots of light came in off the snow at night. It was great. It was incredible. But it was cold.

So was it the landscape and the peacefulness that made that place so special?

It was the security of being able to lie in bed and be safe and warm in your little bubble with all that stuff around you. The woodstove didn't keep that place warm

for more than an hour or two at a time, so it got pretty cold. It was away from things, it was completely my own, completely claimed by me, but if I wanted to be with other people it was clear where they would be or they wouldn't be. I would just have to walk a quarter of a mile up to the main house through the snow and then I would know that there would be people up there to hang out with, or to cook. So it was that clear definition of public and private, I think.

Back to the house you grew up in; what was that like?

Well there were several of them, ..

Which one do you consider the most "growing up" ish?

The one that I lived in between ages four and ten. It was a really old New England house with tiny rooms and you'd bump your head on every doorway, even as a small child (not really). It was kinda strange because the kitchen was on the second floor, it was a house that had been broken up into apartments. My room was really small and it was under the slope of the roof and I had this one window that I could look out of and see lots of landscape, and see out over other roofs of old fish sheds and stuff like that.

It was a single family house while you lived in it?

Yeah, at that time.

And was it sort of suburban in location?

I guess so. It was a small town, so even in the middle of town it felt suburban. When I was ten we moved around the corner to a slightly bigger house that wasn't nearly as nice. It was like a triple decker but it only had two floors. It wasn't nearly as nice because it was boring and confused and the inside was all humble-jumbled - the circulation space was terrible, a lot of dark hallways and really ridiculous turns and corners.

But do feel you grew up there because it was the place that you spent those formative years, or because it had some aspects or memories associated with it that made it more homelike?

I had a lot of freedom there. It was probably because they were formative years, like I could climb out my window and down across some roofs and down an oil tank to get down to the ground if I wanted to. So I didn't always have to go out the front door. That was kinda

nice, especially when I was banished to my room I could sneak out and spend a couple hours outside and then come back in and nobody would know. Which was really good! It was really accessible to the outdoors, I just had to run down the stairs, and out across the front porch, and through a sliding glass door and I was out. And there was a backyard that was all ours, and the backyard was connected to other neighborhood backyards, and places and to the ocean and to docks and everything so it was real...

And from there you moved to other houses in that town?

Yeah, to two others now. One was just around the corner, like I said it was sort of a ugly house layed out in an ugly way, the rooms were just sorta..

You didn't like it huh?

No I didn't. It was a product of trying to get the most out of the smallest amount of space. Sort of a development type of rowhouse, with a flat top and there isn't any slack left for having a bookcase and a hallway or that kind of thing, its all packed space. The way it was set up everything happened through the kitchen, so the kitchen was this zoo in perpetual

disarray. And it didn't have enough light in it, and I'm sure it wasn't decorated very nicely either. It was just sort of dark and meager. But we did add this third floor on to it which was a really nice third floor. The third floor was great, but by the time you made it all the way up there through the rest of this ugly house, I mean you didn't want to be in the house after you came in the front door, so it was very unlikely that you would actually make it up to the third floor. And the driveway and all that other stuff outside was really gross. Just ugly and abrupt and boring.

Of all these places that you grew up, which one was your favorite, which one do you have the best memories of?

The first one, between four and ten. Probably just because I was a kid, but where we live now has a really..the house isn't set up that well but the yard is really, really nice. It's a really special yard. So I think I like that one the most. It's got these big shade trees in the backyard, and the yard has got a lot of interesting spots in it and level changes, and gardens and things stretching out to the back -vegetable gardens, it's not a formal yard. Its sort of a haphazard yard, but it has a real lovely quality to

it, it's fun to walk out to the end of the backyard and come back again.

How often do you go back there?

About once every two months. Once every month maybe. And in the summer time I often spend a month at a time down there.

Do you consider that place more a home then where you are living now?

Yeah, because I feel more connected to the town that I grew up in than I do to the city I live in now.

So whats the best or strongest memory you have of any of these places that we've talked about? is there an powerful image?

Yeah, I would say it's that containment, that intimate space of bedroom, more than anything else, like your own spot, and it's not a big spot either, it's a low ceilinged spot and often it's because the roof is part of the ceiling, it's got you know that corner knocked off of the room. In all the places, there is accessibility to the large space, outdoors ,in general,

that makes that smaller intimate space like a contrast to the rest of the world.

Connected still

Yeah, and the security of not being disturbed there.

But is the one place more than the others that fill that criteria?

I think a lot of those places share the same qualities, the bedshed, the room at my parents house with the big skylight.

One more question. If you could close your eyes and click your heels three times, where would you land? What's your ideal home? Where would it be located, who's there, etc.

Well, I would say the climate is a little better than Boston. It might be a Cape climate or better like down towards Maryland, but with the rocky coast of Maine, that wildness. I guess a place with lots of land and separated houses, like bedrooms separated from the main living place, fields, gardens, wild stuff around the houses, separated houses, I mean not just houses

separated from houses but bedrooms separated from houses, and bathrooms separated from bedrooms, I mean really, just spread out.

Do you have any photos of your homes?

Yeah. This is like one of the most important places to me in the whole world, and its sort of like our clan retreat, it's not big or fancy or anything but its

Clan being your extended family?

Right, right, my grandparents bought it, and my mother and her brothers and sisters grew up with that place ever since they were like four years old they were going to this place its a cottage on a big big big lake so it's got some shore

Where is it located?

It's in Canandaigua, New York. It's a small cottage, which is pretty old, it's probably 150 years old, and it's located on a flat spot at the top of a long slope which is probably 150-200' sloping gently down through all these gardens, and bushes, and flowerbeds and things to the beachfront, near the edge of the beach just

before you get onto the beach there's this row of huge sycamore trees, shade trees which you walk under and then your out on the beach, and it's really hot and sunny on the beach. But this house is just incredibly comfortable, it's got this great big living room with a fireplace, it's not actually that big but it feels big enough, 'cause I knew it as a little kid to now, and you can either be cozy by the fire, and there's all these different chairs you can sit in , that collapse randomly underneath you. The dining room is right off that , and it's got windows all around two sides, and it overlooks this little brook so you feel like your really close to outside while you're eating, and this dinky little kitchen. And around the front of the house there's this porch that wraps around two sides, and it's all lined with every kind of rocking chair you can possibly imagine, and all of us get out there and, now we drink beer and put our feet up on the railing and we just sit out there and like one person will be working out in the front yard and there'll be eighteen people up on the porch watching one person working, that kind of thing! It's just really laid back, and all the life just kinda pours out of this little teeny house which gets packed tight in the nighttime and it all pours out down this lawn to the beach and there's a little beach house down, on the beach where two people can sleep and

when you sleep down there you can hear the waves, lapping on the beach. And if you're up in the big house sleeping you can open the windows and you can hear the little gully riving and bubbling past the house at night, crickets chirping, it's just incredibly peaceful sound.

Do you go there every year?

We try to, almost every year we go. When I was younger we used to go for a month at a time, but now we go for a weekend at a time. But thats just a most incredible spot, and there's lots of land. Not our's, but that we have access to .

So the house itself is nothing to speak of then, it's an old, simple, box basicly?

Yeah, it's very human scale. It's not a simple box , its nicely layed out, and there's a clear definition between public and private again.

But for example, the living room that you talked about earlier, is that..

it's a rectangle.

And what makes that special is having grown up in it maybe, or the firepl..

Yeah, the little fireplace, and there's a certain picture over the fireplace, and there's views back out to the lake, and there's views up the hill to the barn, and there's all the stuff that makes a big difference...and there's lots of attachments to those things, memories,.. That's definitely my favorite place in the whole world , if I was to choose one, but I don't think I would want to live there, because its a place where you go to get kinda gassed up for all the other things you do.

Do you think it would be the same going there if you didn't have all your friends and relatives there, would it still have that special quality?

No, an identical place like it wouldn't do the same things for me if it didn't have the attachments of all my relatives , my grandparents, ...when I go there I feel like I'm basically with my grandparents, that they're around, and that they're watching so that there is a real connection with my past there that does not exist anywhere else. You can have an identical house in

an identical situation, but if it didn't have those memories and connections it would just be a nice house near the lake with a nice lawn.

excerpts from interview f3 - an elderly woman

This interview began with a tour of her apartment.

You live here by yourself?

By myself. My mother was with me, but she's been dead since '65. This here is supposedly a sun porch--it should have been on the other side of the house because the sun is better there in the afternoon, when you could sit down.

Yeah, this is sort of the north side of the house.

It's sort of a closet for me...

So you don't use this--

Well, I don't use it to sit in really--storage, mostly.

It's a nice little room.

Well, sometimes in the summer, way back, I did sit in it, but then I got kind of to a closet with it now. And

these--a grand niece of mine took her great grandmother's bedroom set, and that left me without a lot of drawer space. And so I stuck some things in here.

This is beautiful, this piece of furniture.

That's old, very old. We had a lot more, but I gave them to different people who really wanted them.

They look like great volumes.

And we had both the Brittanica and Catholic Encyclopedia. I don't know where the Brittanica went to but anyway...

It's quite lovely in here, it's nice wallpaper and everything-- have you--

Oh, I've done this twice since we've lived here--oh, more than twice, it was done when we came in, and I have done it twice.

How long have you lived here?

Since forty something. At least forty five years. And then this is the pantry and the kitchen. It's a nice brighter pattern. And then you see we have the back porch, and...that is my grocery cabinet.

So you can really have a lot of stuff stored there.

Well yes.

Do you use the back porch much?

Yes, we do, we use it a lot in the summer. We have chairs down cellar that we bring up and--a couple years ago, that terribly hard summer, we were out there all the time. My sister made here, or I made there cause she's in an apartment, if you know West Street at all. Where that school part is now, that was a public garage. They stored cars there, but you had to bring them there and all.

When you sit on the back porch does it matter, that you see all the neighbors so close?

It doesn't bother me. The only thing that bothers me at all--it doesn't bother me, but I think it's kind of stupid, the mother and father in that house on the second floor, are delightful and pleasant, but the two kids never speak to you. Cause we were never brought up that way, and you aren't either.

Yeah, I think that's part of the city, sometimes, I guess.

Well, it is, but we've seen them grow up. Now this is a very good bedroom. We used to have the twin beds in - see they don't have that extra window downstairs--That one on the far side.

Uh huh, on the end. Is this your bedroom?

This one I have always used, yes

It's quite lovely.

It really is, as a matter of fact, the layout here is much better than your house.

I won't debate that.

Neither will Amy--she comes over--"Oh, I love this!"

She probably appreciates your decorating style as well.

Well,...This is an old fashioned bathroom, but I like that tub because I can get into it and feel like I can hang onto something to get out. And a plumber came in the other day and said "Oh, it's old fashioned" and I said "But it works". I never will give up that tub. In fact Amy bought one like that.

I bet she paid a lot of money for it.

No, I wouldn't give up that bathtub for anything. I was just debating a shower when we had that awful oil spill...so we'll get it maybe in the spring.

So to put a little curtain around it?

Well, hers goes the whole length of the tub. We had one on Maple Ave.--her shower curtain goes all the way around the tub...This is the second bedroom. One thing we don't have is much closet space. We have that, and one in each bedroom and one in the hall.

This one doesn't--I guess it's smaller than that room.

It is smaller than that room. We had a double bed in here, a bureau, a chest of drawers...It's very comfortable and very pleasant. We get loads of sun.

Yeah, it's the sunny side.

And then of course this door in here goes up to the attic.

That's mostly just storage?

There isn't much up there now, because I've gotten rid of a lot of the things. My mother painted that...that is supposed to be what they call Norton's Woods in Cambridge. Do you know where the Theological school is--that used to be woods...Now what can I do for you?

I'd like to get a few more questions out for you, if you have the time. You must like this house a lot, since you've lived here a long time. Do you own the whole house?

No, I own half of it. My sister's in-laws own the other half, and they rent it out. The children are here from Germany, and one of them's in school in Boston at

Boston Latin, but they're not here right now.

But the whole house is sort of in the family, then.

Well, listen, "family" if you want to call it that. I think we're really very independent from one another.

So really it's just this half of the house.

The only thing is the paying of the taxes and the paying of the mortgage. We manage that very well.

Your part includes this floor and the attic?

She has the first floor. We have two separate basements. There's a common door here--I put the meters outside so I don't have to tramp down the cellar. There's the common door there. We have separate heaters and hot water. Separate bills.

So there's never been any problem. When you bought the house did you two buy it at the same time?

Yes. It's not really independent. See, her sister-in-law was living here at the time, alone downstairs and I was alone because my mother died in

'65, and so...

You lived here and rented before you bought it?

No, well, Yes, because Father Albert was being ordained and they wanted a house so that he could have a place to come to for days off and such and it was a pretty big house. We did take in some nurses from the city hospital, but...it was too much for both of us, so my mother said yes... but she always wanted to go back someplace and go upstairs to bed, she hated being on one floor. And yet she was better off when she was on one floor. So she was ninety four when she died...So, back to your questions.

You must like this place a lot, as I said before.

Well, I'm used to it, and I'm not frightened at all, and I think I have very nice neighbors. It's quiet, and Mr. Foster gave me his telephone number, because it isn't listed and said call me...that's a long time ago, when Brian Leary was there, he gave me his telephone number. I find the neighborhood very nice.

Is that the main reason you're comfortable here, because of the neighborhood?

Well, I've been in Cambridge all my life. And I am not young. I'll be eighty shortly. But, no--well, we know the neighborhood so well.

Where else have you lived in Cambridge?

Just around the corner on Maple Avenue.

Only that house and this house?

Uh huh. And then we only came from out of Inman Square. Off Beacon Street, on Dickenson Street, just out of Inman Square with my grandmothers. And my mother and father lived there after they were married, and my brother who was older was born there, and I was born there. Our generation wasn't born in hospitals. My sister was born on Maple Avenue. Just around the corner.

So did you not live in the Dickenson house very long?

I was about three or four years old--and we left there after my father died.

And then did you move to Maple Ave after that?

Yes.

And then you stayed there for quite a while after that.

Let's see...oh, yes, because we came up here in the forties.

So would you consider that house to be the one you kind of grew up in?

Oh, I did--in Maple Ave.

Do you still have attachments to that house there?

Not anymore, because they changed it too much. Inside you wouldn't recognize it.

What was it like when you were there?

Well, this was our front hall carpet. And on the right was what we called the parlor, which had more formal furniture--you used it on special occasions. Then on the left was a very nice library, with dark green wood in it. They painted it stark white, which was not restful as the dark green. And it had built in bookcases on a wall over there. Four bedrooms. Now they rent the second floor.

And when you lived there did your family have the whole house?

Yes. There were five of us--not five children, five people.

So you had a brother and a sister?

Yes. There were supposed to be more, but they didn't arrive. My mother lost two or three children.

So, what was your favorite part about that house on Maple Avenue?

Just generally the whole place. And the neighbors next door were there--we really enjoyed it.

You had your own room in that house?

My sister and I took one room, my brother had one room, my mother and father, and then we had an extra bedroom. My sister and I shared that room for a long time until she got married.

And you're still pretty close to your sister--she lives just down the street?

She just lives down there, and her husband was very good to me, too. He's been dead about eleven years. He was superintendent of schools. Mr. Conley.

What prompted the move from Maple Ave to Merrill Street?

Well, it was getting to be quite a problem to take care of it, because it was a big place.

Was it at that point just your...

Just my mother and me.

Your mother and you--cause your sister had moved out--

She had moved out when she got married.

Is your brother still around?

My brother, no. He's been dead since '69. He wasn't around here very long--he worked for the New Haven Railroad, and then he resigned from there because things weren't the way he wanted them. And he worked two or three places and then he went to New York for a small railroad there. He always wanted to work for the

railroad, even when he was little he played a lot of railroad.

It's funny how that's sort of something that's almost in the past, now, but some people really like railroads.

Right, well, my brother and sister-in-law used to go to New York a lot. They would always take the railroad.

I still do, if i have the choice.

Where do you come from?

(discussion of victor's past)

Do you think you like this place more than the house you grew up in?

No, I would always love that, the Maple Ave house. The memories there are great, because we had, across the street we had cousins, and they had a family, but there were two or three branches that lived in that one house. And there were maybe twelve kids. And then on one side there was six or seven of them, and on the other side there were seven, and then across the street

there were eight-and they always used to say they could put seven Fords in one Buick, and they owned a Buick, and they're name was Ford, so they could put seven Fords in one Buick... They would flood the back yards down there, and we could skate, and now if you walk through Maple Avenue, they're putting up a condo between two houses, right next to me. We could coast from that yard, right to Fayette St. I think for city people, we had more fun than kids brought up in the city today. This, right here, we used to come up, and we knew the people on the first floor over there, and on two floors over there. And we used to play marbles here. But you don't hear children say they do those things today.

No, you see them make a lot of noise on the bicycles...

You're so young, I shouldn't be telling you--

I'm not that young. The other place seems more homelike than this one, you think?

Well, I'm so used to this one now, that it's home. But we really loved Maple Avenue. And my mother did not want an apartment. I first would have gone into an apartment, but she didn't like them. She didn't like

closed doors. You see, you go into an apartment, there are corridors, hallways, and all the doors are closed, she didn't like that.

So do you think that was one of the reasons that--

No, it was just time to get rid of the house. She thought it was too much responsibility.

But i guess on maple avenue, it was a whole house, rather than an apartment.

It was a whole house--it wasn't even like this, you see, the whole place was ours.

Uh huh, so that makes a big difference.

And she was in a two-family in her own mother's house, on the first floor, but like that was with her own family, so she would have, as they say, freedom of the port.

Are there any other memories of note?

No, we always had good times there, and we were always taught to bring our friends in, and...

If you were going to picture your ideal house now, or most homelike place--I assume it would be in cambridge.

Well, I don't think we would, no because we, we had a nephew who we lost right after Thanksgiving, who said, "Oh, why don't you come out? (They were in Dover, which is a ways from here, an hour) I could get you an apartment in Wellesley", and we said no. We wouldn't know anybody--we might know them, and a few people like that, relatives, or something, but we wouldn't know anybody, and I don't think you can do that, at our ages and be happy. I mean Mrs. Melanie--maybe it's all right that she's gone into a place in Arlington that's all elderly, but I don't know, I don't think you can. And my sister would come here, except that we, maybe we're too practical, but she doesn't want (to buy) this if anything should happen to me, so she's content in her apartment. I go there every Sunday, and she comes here mostly every day. I can usually find a place to park mostly every Sunday, and they say I can go into her parking space for a couple of hours, but some people have big cars...etc. So we just do the best we can, and we're very grateful if we're on our feet.

You do pretty well.

Well, we try, anyway.

That's pretty good. So am I hearing you correctly in that if you were going to have an ideal place that you wanted to be, in your mind, if you could click your heels three times and be anywhere, would this be it, or is there another place that would be more ideally homelike?

No, I don't think that there's any other place that I could be more contented, I think that probably a smaller place would be all right, but I'm very content. We have friends. We have a mother and daughter, and the mother works two or three days a week and the daughter teaches. I don't think they eat--they don't eat three meals at home a day, they eat breakfast but that's about all. And Friday, Saturday, Sunday, they don't stay home. Whereas, just the other day, eating, my sister said, I don't know how they--and they have a beautiful home, but they don't seem to want to stay and eat. But, no, and when I was in college we were very content and very happy to come home for vacation. Then you had that craze of everybody going to Bermuda or Florida, or...we couldn't see it. It's very different, different world altogether from where we grew up. I'm very content here. And I'm not one bit afraid here, I

mean, many times, the Bolks were away, at Christmas time, they were away in the summer sometimes, and Peter and Katrina have gone away on the weekends, but I'm not afraid here. Of course I don't think I'd want a first floor of any kind--I'd want a second floor, anyway, and I wouldn't want to go very high, I never could go to the Pru, and I wouldn't want to, and we have friends who bought in Harvard Square, at that new place in Harvard Square, and I don't know if she was just kidding or what, but she said if the power goes off, we can't get in or out of the place--into or out of it.

Well, I don't know..

I don't know, I think they must have keys even if the power is off the keys must work or something, but no, I wouldn't want to live up there, either. As a matter of fact, when we were kids, Maple Avenue was practically country with the beautiful trees. and then for a while they kind of went, but not too badly, but they're pretty much back now.

Uh huh, the trees are pretty good sized.

Yes, it has stayed pretty well, but don't know how that condo goes with the people who live next...

What's your favorite aspect of this apartment other than that your friends are here and that, the location.

Of course, it was a better location when the the buses ran on Broadway...but as far as that goes, just that it's very comfortable and the neighborhood is very, like a home.

What part of this apartment do you spend the most time in?

In that little room there.

Why is that?

Well it's just comfortable and cozy. It's quite comfortable in the summer because I can open both windows, and the attic door, which with the window open usually upstairs, you get air. I like my bedroom, that's very comfortable.

But, this little room has a window on the street.

Two.

Two windows on the street. So do you look out them very much?

I don't look out them very much, I really don't. Somebody used to say to me, "if I lived up here, I would be out of the window to see what's going on." If I hear a noise, maybe I--you know, but I don't look out the window really too much. Well, I tell you, I try to make myself content. I knit, and I read a lot. (talks about the book she is reading--about racism in Boston)

So you were a teacher?

I was a teacher of physically handicapped children, ones at home and ones that were hospitalized. No, but I'd be content in a similar situation--I don't think I'd want to go.

It seems like you're quite stable here.

Oh, I think so, and I think--I mean my niece has moved a hundred times. She's been married thirty years and she's lived ten different places. This is the longest she's lived any place. In Dover she was fourteen years, now she's down at the Cape. I don't know how long...

So during holidays you get together with your sister?

Well since they've been around here, we've always gone there holidays. We didn't go the past year ago, but we

were here this Thanksgiving, and had a very pleasant time.

What do you really think makes a house a home?

Having it comfortable. And if you don't feel like getting up today, you don't have to. And you can do as you please. And I don't think you can put two or three generations together.

So for you it's sort of your own place.

Yeah, this is my own place.

And by having that much control over it it makes it your home.

Oh sure, I think my sister and I could get along fine, and she has come down when I didn't feel well, and I have gone up there and stayed, but, no, I think that it's just that it's your own, and you get your own habits and all.

In your place on Maple Ave, though, you have as much control over that?

Well, see we were living with a whole family then, and you, well, we got along all right, we didn't have too many squabbles.

But what made that seem real homelike?

Well, we had good family relations, and we had a good mother and father. Strict, but sometimes I think it's better.

Sort of good memories of that.

Oh, very good family life, yes.

You're lucky.

Yes. I think--I can't see just moving out of the family, but I suppose some people tell them to go and to get on their own.

excerpts from interview m3 - a recent immigrant

I have many questions, i'm not going to ask you them all, but i'll ask you what seems appropriate. How long have you lived in this apartment now?

One and a half years.

Do you like living here?

Yes

What do you think is the best part about living in this apartment?

The facilities.

Meaning that it's easy to get to places or that it has good hot water?

It has good hot water, it has good cold water, every

kind of utilities, lights, gas, water, etc. and if you have a problem you can just call them and they will come and fix it.

So did you live in other places in the boston area before this one?

No, since I came here I have lived in this apartment.

So it's been for one and a half years which is the whole time you've been here in the United States.

Yes.

So that's the best part about it, is the utilities, isn't it?

Yes, and lots of our family's peoples live in this building, so if I have any problem I can go to my cousin's apartment, or my uncles apartment. It's a nice building.

So is that part of the reason that you moved in here, was because you had your uncle and other family relatives...

Well, since my mother and my parents came here, they've been here three or four years, and my uncle already lived here, so they tried to live here.

So what would you say the worst part of this apartment is?

Too many people. There are twenty-two floors to the building, and there are twelve apartments to a floor, so it's like, you know...that's all.

You don't mind living on the fourteenth floor?

No. That's okay.

And you don't mind that it looks very much the same as the other apartments on the outside?

No.

So what do you think is the nicest part of the building, of the room, the apartment?

Big room, very good.

Did you live in several places in india before you came here?

In India? I lived in Bildemora which is in the Kudjar state, and it's a very nice state, it's a rich state, next to Bombay. I lived in Bildemora and Kundin, the only two cities I lived in.

You were living with your parents then?

I lived with my grandparents, and my uncles.

And how long did you live in those two places.

I lived in Bildemora nine or ten years, my parents were there; I was living in Kundin, it's another place, and I just lived one year there just to go to school.

Would you say that the place that you would call home there, in Bildemora?

Yes, I was living with my grandparents there, I lived ten years there, and three or four years in another place...my mother used to live there.

What was that house like?

It's a really big house in the country, in India, it's not like an apartment, it's just like a house, you have

two or three floors in your own house, and it's like,
BIG.

And what did it look like?

We have pictures...

(they go and get the pictures)

We had three front doors at our house in India. There's a window between here and here, and another between...Here's the livingroom, and this is the bedroom. The bedrooms are bigger than the livingrooms in our country, and this is the kitchen, and bathrooms,... and we have this yard so you can have some kind of flowers.

So you can have your private garden?

Yeah you can just fence it.

And would there be many of these buildings in a row?

Yeah.

So they'd be like this way and this way.

Yes, so some of them would be smaller,...

So is the place that you grew up, then?

Yes.

What was the nicest place in your house?

We had facilities like gas, we had to buy our own gas in bottles.

So you very much seem to appreciate the comforts--

So that's why I live over there, because where my mother and dad lived, there was a high school in that town--it was not a city, but there was a high school, and my grandparents wanted me to attend. And live with them and go over and study. I was in high school when I was in eighth grade.

This is our house, we took the picture at night.

This is the outdoor area? It looks very popular.

This is a picture of my sister's marriage.

What do you think about this place now, if you compare this place with the place you live now, this apartment?

I've never lived in apartment, so I like apartment, too.

So do you like either one better, perhaps?

(?)

If you could consider one place home, which would it be? Would you want to go back to this house in india?

Yes. I just left there to come over here.

You came here because your parents were coming here?

Yes.

If you could have any place you wanted to live, what place would you want to live, and what kind of place would it be?

I would like to live in a small home, (town) so quiet up there(?) and all kind of utilities, facilities, and a garden and a back yard. The kind of house I had in

India.

Where would that be?

In the United States.

Would you live by yourself or would you like relatives or other people--is that important?

Yes, because I don't like to live alone. I like to live with relatives and other people.

What's the nicest place you've ever lived?

In India. (point to photo of Indian house) In this house.

And what made that the nicest place?

Because like all the houses are together. They are not the same, they are different kinds of houses over there, and there are two or three floors in your own house. That's why I like to live there, you can just go to each other's friends house, have fun-- there was a playground we had here, and then we had other houses up here. We played games over here. There are not

apartments too much in my country.

*So you have pretty good memories of this place then?
Any special holidays, weddings?*

You know the population of India--it's lots of people over there. Each street there's lots of people living. They get married; in my country it's really strict to get married. You have fun in the time during the married time. People talk to each other.

So did that happen in the street outside the house, or inside the house?

No, outside of the house.

Do many people come inside the house?

Well, my relatives come over here, my aunties, neighbors...

But if you had a party, this didn't happen in the house. The livingroom is small, you said.

No it is bigger than over here, but the people like to stay outside.

Nord House Existing - Run 1

Educational/demo CALPAS3 V3.12

LUDLOW, VERMONT

Weather: COLD.GMY (Cold generic)

S U M M A R Y

Run period: JAN-01 - DEC-31

Conditioned floor area: 994 sf

SPACE CONDITIONING LOADS

=====

	Run totals		Peaks
	kBtu	kBtu/sf	kBtuh
House			
Cooling	10080	10.141	25.525
Heating	30772	30.958	23.326

ENERGY CONSUMPTION

=====

	Run totals			Peaks
	kWh; kBtu	Prop line kBtu/sf	Source kBtu/sf	kW; kBtuh
Electricity				
House cooling	1477	5.070	15.211	3.739
House heating	9016	30.958	92.873	6.835
Total	10493	36.028	108.084	
Building total		36.028	108.084	

OPERATING COSTS

=====

Electricity @ 0.05 \$/kWh	\$	525	
Fuel @ 0 \$/kBtu	\$	0	
Total	\$	525	(\$0.53/sf)

appendix

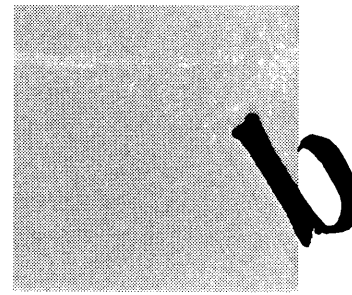

Existing House : CALPAS

Educational/demo CALPAS3 V3.12

LUDLOW, VERMONT

Weather: COLD.GMY (Cold generic)

Line

```
-----  
1  TITLE Nord House Existing - Run 1  
2  SITE      TZN=5          LOCATION=LUDLOW, VERMONT  
3  HOUSE     FLRAREA=994    VOL=7455  
4  ROOF      AREA=480      AZM=0      TILT=45    UVAL= .05  
5  WALL      NAME=ROOF2     AREA=225   AZM=180    TILT=45    UVAL= .05  
6  WALL      NAME=ROOF3     AREA=165   AZM=180    TILT=13.5  UVAL= .05  
7  WALL      NAME=SOUTHWALL  AREA=219.25 AZM=0      UVAL= .08  
8  WALL      NAME=WESTWALL  AREA=296.5 AZM=90     UVAL= .08  
9  WALL      NAME=NORTHWALL  AREA=303   AZM=180    UVAL= .08  
10 WALL      NAME=EASTWALL   AREA=270   AZM=270    UVAL= .08  
11 WALL      NAME=SOUTHDOOR  AREA=21    AZM=0      UVAL= .2  
12 GLASS     NAME=SOUTHGLASS  AREA=15.75 AZM=0      NGLZ=2  
13 GLASS     NAME=WESTGLASS   AREA=21    AZM=90     NGLZ=2  
14 GLASS     NAME=NORTHGLASS  AREA=81    AZM=180    NGLZ=2  
15 GLASS     NAME=EASTGLASS   AREA=47.5  AZM=270    NGLZ=2  
16 OPCOST   ELPRICE=.05      HEATING=ELECTRIC  
17 SOLARPRINT      FEB-15  
18 SOLARPRINT      AUG-16  
19 PRINTDAILY      FEB-15  
20 PRINTDAILY      AUG-16  
21 PRINTHOURLY     FEB-15  
22 PRINTHOURLY     AUG-16  
23 END
```

*** No input errors.

*** Beginning simulation 04-JAN-80 18:20:23

NORD HOUSE PROPOSED

S U M M A R Y

Run period: JAN-01 - DEC-31

Conditioned floor area: 1008 sf

SPACE CONDITIONING LOADS

=====

	Run totals		Peaks
	kBtu	kBtu/sf	kBtuh
House			
Cooling	14383	14.269	29.513
Heating	8131	8.066	12.440
Sunspace			
Heating	71	0.070	1.836

ENERGY CONSUMPTION

=====

	Run totals			Peaks
	kWh; kBtu	Prop line kBtu/sf	Source kBtu/sf	kW; kBtuh
Electricity				
House cooling	2107	7.134	21.403	4.324
House heating	2382	8.066	24.199	3.645
Sunspace heating	21	0.070	0.211	0.538
Total	4510	15.271	45.813	
Building total		15.271	45.813	

OPERATING COSTS

=====

Electricity @ 0.05 \$/kWh	\$	226	
Fuel @ 0 \$/kBtu	\$	0	
Total	\$	226	(\$0.22/sf)

Proposed House : CALPAS

Educational/demo CALPAS3 V3.12

LUDLOW, VERMONT AZMSOUTH=10

Weather: COLD.GMY (Cold generic)

Line

```
-----  
1  TITLE Nord House Proposed  
2  SITE      TZN=5          LOCATION=LUDLOW, VERMONT    AZMSOUTH=10  
3  HOUSE     FLRAREA=1008   VOL=7455  
4  ROOF      AREA=360      AZM=0      TILT=45    UVAL= .025  
5  WALL      NAME=ROOF2     AREA=636   AZM=180    TILT=45    UVAL= .025  
6  WALL      NAME=ROOF3     AREA=48    AZM=90     TILT=45    UVAL= .025  
7  WALL      NAME=ROOF4     AREA=48    AZM=270    TILT=45    UVAL= .025  
8  WALL      NAME=SOUTHWALL  AREA=93    AZM=0      UVAL= .03  
9  WALL      NAME=WESTWALL   AREA=252   AZM=90     UVAL= .03  
10 WALL      NAME=NORTHWALL  AREA=322   AZM=180    UVAL= .03  
11 WALL      NAME=EASTWALL   AREA=210   AZM=270    UVAL= .03  
12 WALL      NAME=EASTDOOR  AREA=42    AZM=270    UVAL= .1  
13 WALL      NAME=WESTDOOR  AREA=21    AZM=90     UVAL= .1  
14 INTWALL   AREA=20    THKNS=8    MATERIAL=BRICKFACE  
15 GLASS     NAME=SOUTHGLASS  AREA=120   AZM=0      NGLZ=2     UVAL= .25  
16 GLASS     NAME=WESTGLASS   AREA=48    AZM=90     NGLZ=2     UVAL= .25  
17 GLASS     NAME=NORTHGLASS  AREA=26    AZM=180    NGLZ=2     UVAL= .25  
18 GLASS     NAME=EASTGLASS   AREA=48    AZM=270    NGLZ=2     UVAL= .25  
19 INFIL     ACBASE=.5  
20 SUNSPACE          FLRAREA=90  
21 SSSLAB      AREA=168   THKNS=6    MATERIAL=BRICKFACE  
22 SSGLASS    NAME=VERTGLASS  AREA=84    AZM=0      NGLZ=2     UVAL= .25  
23 SSGLASS    NAME=SKYGLASS   AREA=14    AZM=0      TILT=45    UVAL= .25  
24 SSCOUPLING  UATAHS=1     VENT=NATURAL    AREALOW=18  HDIFF=6  
25 OPCOST     ELPRICE=.05   HEATING=ELECTRIC  
26 SOLARPRINT          FEB-15  
27 SOLARPRINT          AUG-16  
28 PRINTDAILY          FEB-15  
29 PRINTDAILY          AUG-16  
30 PRINTHOURLY         FEB-15  
31 PRINTHOURLY         AUG-16  
32 END
```

Little House Proposed

Educational/demo CALPAS3 V3.12

LUDLOW, VERMONT AZMSOUTH=10

Weather: COLD.GMY (Cold generic)

S U M M A R Y

Run period: JAN-01 - DEC-31

Conditioned floor area: 328 sf

SPACE CONDITIONING LOADS

=====

	Run totals		Peaks
	kBtu	kBtu/sf	kBtuh
House			
Cooling	10842	33.056	24.360
Heating	568	1.731	4.790

ENERGY CONSUMPTION

=====

	Run totals			Peaks
	kWh; kBtu	Prop line kBtu/sf	Source kBtu/sf	kW; kBtuh
Electricity				
House cooling	1588	16.528	49.584	3.569
House heating	166	1.731	5.192	1.403
Total	1755	18.259	54.776	
Building total		18.259	54.776	

OPERATING COSTS

=====

Electricity @ 0.05 \$/kWh	\$	88	
Fuel @ 0 \$/kBtu	\$	0	
Total	\$	88	(\$0.27/sf)

Proposed Cottage : CALPAS

Educational/demo CALPAS3 V3.12

LUDLOW, VERMONT AZMSOUTH=10

Weather: COLD.GMY (Cold generic)

Line

```
-----  
1  TITLE Little House Proposed  
2  SITE   TZN=5           LOCATION=LUDLOW,VERMONT   AZMSOUTH=10  
3  HOUSE  FLRAREA=328     VOL=2952  
4  ROOF   AREA=200        AZM=0      TILT=45    UVAL= .025  
5  WALL   NAME=ROOF2      AREA=360   AZM=180    TILT=45    UVAL= .025  
6  WALL   NAME=SOUTHWALL  AREA=93    AZM=0      UVAL= .03  
7  WALL   NAME=WESTWALL   AREA=99    AZM=90     UVAL= .03  
8  WALL   NAME=NORTHWALL  AREA=120   AZM=180    UVAL= .03  
9  WALL   NAME=EASTWALL   AREA=78    AZM=270    UVAL= .03  
10 WALL   NAME=WESTDOOR   AREA=21    AZM=90     UVAL= .1  
11 SLAB   AREA=96           THKNS=4    MATERIAL=CONC100  
12 INTWALL AREA=64           THKNS=24   MATERIAL=BRICKFACE  
13 GLASS  NAME=SOUTHGLASS   AREA=100   AZM=0      NGLZ=2     UVAL= .25  
14 GLASS  NAME=EASTGLASS   AREA=42    AZM=270    NGLZ=2     UVAL= .25  
15 INFIL  ACBASE=.5  
16 OPCOST ELPRICE=.05      HEATING=ELECTRIC  
17 SOLARPRINT          FEB-15  
18 SOLARPRINT          AUG-16  
19 PRINTDAILY          FEB-15  
20 PRINTDAILY          AUG-16  
21 PRINTHOURLY         FEB-15  
22 PRINTHOURLY         AUG-16  
23 END
```

*** No input errors.

*** Beginning simulation 05-JAN-80 00:40:11

*** Run complete.

The stories we Italian writers can tell are marked on one hand by the sense of the unknown, and on the other, by the need for construction, for exactly drawn lines, harmony, and geometry. This is the way we react to the quicksands we stand on.

italo calvino

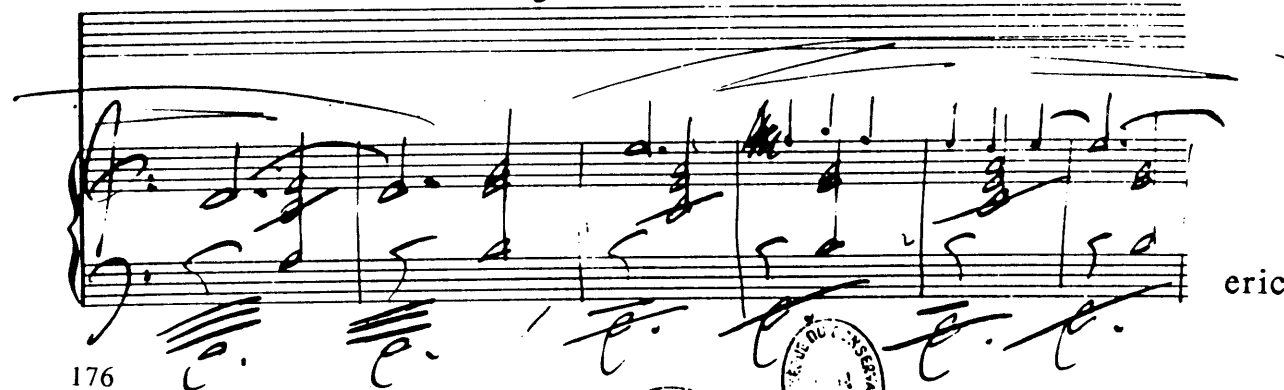
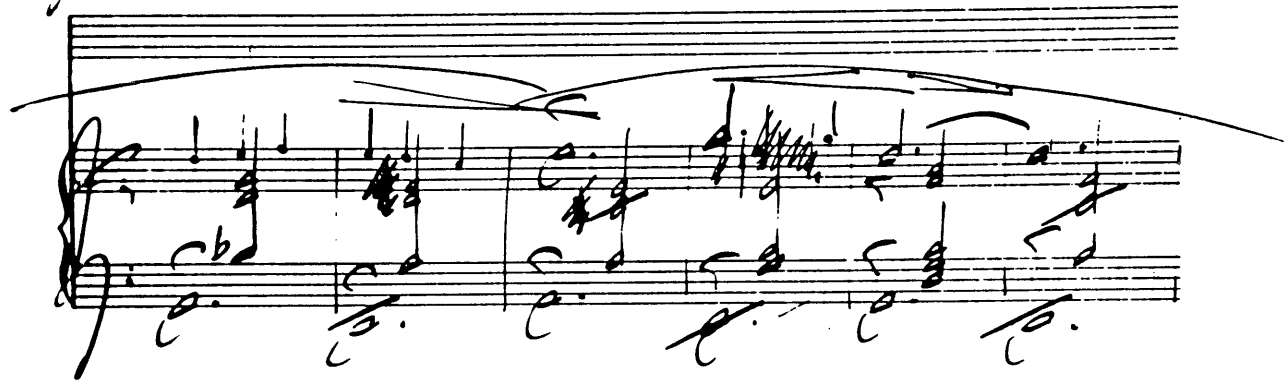

eric satie





max ernst

OCT 19 1986

NOV 18 1987

APR 17 1988

MAY 22 1988

OCT

