



3 9080 00539 1526

RATIONALIZED STRUCTURAL SYSTEMS FOR DIVERSE APPLICATIONS

by

Floris Panayides

Bachelor of Architecture
Pratt Institute
Brooklyn, New York
1985

SUBMITTED TO THE DEPARTMENT OF ARCHITECTURE
IN PARTIAL FULFILLMENT OF THE REQUIREMENTS OF THE
DEGREE
MASTER OF SCIENCE IN ARCHITECTURE STUDIES AT THE
MASSACHUSETTS INSTITUTE OF TECHNOLOGY

JUNE, 1988

© Floris Panayides

The author hereby grants to M.I.T.
permission to reproduce and to distribute publicly copies
of this thesis document in whole or in part

Signature of the author

Floris Panayides
Department of Architecture
May 3, 1988

Certified by

Waclaw Zalewski
Professor of Structures
Thesis Supervisor

Accepted by

Julian Beinart
Chairman
Departmental Committee for Graduate Students

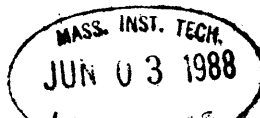

Rotch

to my parents, Andreas and Christalla

ACKNOWLEDGEMENTS

During the two years I spent at M.I.T., the essential aim guiding all my work has been the unification of the conception of structure and space into a singular, holistic design process.

In working towards this goal, my source of inspiration, motivation and enlightenment has been my advisor, Professor Waclaw Zalewski. I am honored to have had the opportunity to work under the dedicated guidance of a true Master. This thesis is as much a product of his brilliance as it is of my efforts.

I would also like to express my gratitude to Professor Eric Dluhosch. His contribution to my learning has been crucial. I thank him for all information, advice, encouragement and, above all, for his sincere commitment to architecture and education.

My friends and colleagues Ahmereen Reza, Valeria Koukoutsis and Angel Garcia Alvarez I thank for their valuable assistance and comments.

Finally, I would like to thank my dearest Aida, who has lived through every moment of the development of this work. From our discussions I drew ideas; from her expertise, knowledge; and from her whole-hearted and unconditional support, the strength and courage that pulled me through.

TABLE OF CONTENTS

Acknowledgements	1
Table of Contents	3
Abstract	5
Chapter 1	
Industrialized Building:	
A Response to the Need for Economy	6
Chapter 2	
Problems in the Performance of Panel Systems	11
2.1. Resistance to Change and Diversity	14
2.1.1. Technical Restraints of Panel Systems	17
2.2. Panel Systems Applied to Diverse Contexts	18
2.2.1. Limited Applicability vs. Economy and Mass Production	18
2.2.2. Panel Systems Transplanted: The Case of Egypt	23
Chapter 3	
Open Systems:	
An Alternative to Industrialized Construction	31
3.1. Introduction to Open Systems	32
3.1.1. Definition	32
3.1.2. Advantages of Open Systems Over Panel Systems	36
3.2. Open Systems Applied: Conditions and Requirements	38

Chapter 4	
An Open Structural System Developed: Slab-Column System	44
4.1. Evolution	44
4.2. Slab-Column System Description	46
4.3. Slab-Column System Compared to Panel System	54
4.3.1. Amount of Reinforced Concrete	55
4.3.2. Amount and Variability of Elements	57
4.3.3. Joints and Tolerances	60
4.4. Adaptability of the Slab-Column System to Diverse Sites	63
Conclusion	70
Slab-Column System: Drawings	73
References	107
Bibliography	108

RATIONALIZED STRUCTURAL SYSTEMS FOR DIVERSE APPLICATIONS

by
Florin Panayides

Submitted to the Department of Architecture on May 3, 1988
in partial fulfillment of the requirements for the Degree of
Master of Science in Architecture Studies

ABSTRACT

Industrialized building emerged as a consequence of the need for the economical and rapid provision of healthy and safe living environments.

In both Europe and developing countries, concrete panel systems were gradually established as the primary building prefabrication method. However, concrete panel buildings demonstrated in time resistance to change, lack of adaptability to diverse sites and contexts and inefficiency in the use of the relatively expensive cement and steel.

Open systems offer an alternative direction to industrialization in construction. In open systems, the differentiation of permanent from non-permanent elements and the organization of only the permanent ones in the form of a rationalized structural system (characteristic of open systems), allow for the variable position and material composition of all walls. Nevertheless, conventional frame systems are not easily adaptable to diverse sites, since structural interdependency of bays and the need for alignment of elements allow only limited variability of building form.

The developed Slab-Column System, presented herein, is a rationalized structural system which goes a step beyond conventional frames. Besides offering the possibility for flexible and changeable divisions of its structural platforms, the system is adaptable to a diversity of site conditions, thus broadening the applicability of large-scale prefabrication.

Thesis Supervisor: Waclaw Zalewski
Title: Professor of Structures

CHAPTER 1

INDUSTRIALIZED BUILDING: A RESPONSE TO THE NEED FOR ECONOMY

Industrialization in building emerged from the need of constructing large projects economically and fast. In post World War II Europe, prefabricated buildings came as a response to the need for immediate provision of new space, for housing, schools, hospitals. Today, in developing nations, similar immediate needs exist for the provision of safe and healthy living environments and other facilities for large populations. Since speed and economy are critical constraints, prefabrication is practiced. Even in well industrialized and developed countries, such as the United States, due to the high cost of labor and other costs associated with the duration of construction (interests on loans for example), prefabrication again is advantageous in terms of economizing.

Industrialization is a fact of our era. Traditional craftsmanship is today a luxurious method of production applied to artifacts, while most elements of necessity are manufactured

mechanically; and the built environment, when a necessity, cannot be excluded. Where the constraints of economy and speed prevail, especially in developing countries, prefabricated buildings are being constructed and will probably continue to do so in the future.

Industrialization and technological advancement are not monopolies of the western world. Every country has both the right and the need to advance and evolve. In the case of industrialized building, the issue is not whether it should or should not occur in various parts of the world; the issue is, how industrialization in construction can be adapted appropriately to different places so its product can respond to the conditions of each diverse context.

The prefabricated buildings that have been, and are still being constructed, especially in developing countries, have generally not been successful in responding to regional conditions (figs. 1-4). The reasons why, and the ways in which such buildings have been failing, will be discussed in the following chapter. At this point, what is important to clarify is that a construction method cannot be held responsible for the way

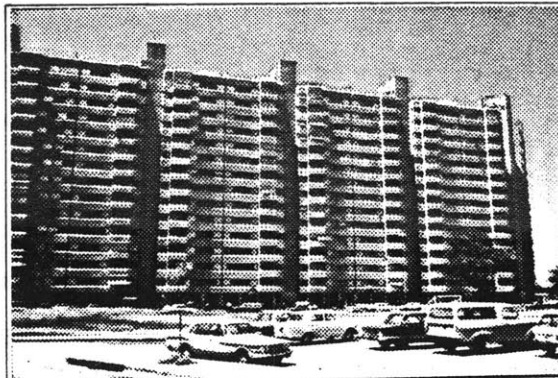

Fig.1 Housing near Buenos Aires, Argentina



Fig.2 Housing in Rio de Janeiro, Brazil



Fig.3 Housing in Cairo, Egypt



Fig.4 Housing in Prague, Czechoslovakia

in which structural systems and buildings are being designed. R. Bender puts it as follows:

Many of us blame the industrial process for the chaotic environment we live in, rather than placing the blame where it belongs: on men and institutions who have not learned to control it. [1]

It is not the purpose of this investigation to promote prefabrication as a method of construction for its own sake. One cannot have a preference for prefabricated buildings rather than traditional ones, simply as a matter of taste. As a choice of using concrete, wood, stone, or mud, must be made based on contextual conditions, similarly must be made the choice of construction method to be employed. The builder must view materials and methods objectively. These are the tools of the trade, which must always be appropriated to requirements and constraints that define each separate project.

What is the purpose of this thesis, is to present new directions for the design of prefabricated structural systems, which can lead to the improved performance of buildings that need to use large scale prefabrication. However, even though some structural systems can better than others allow their diverse and variable application without imposing stringent conditions to the

buildings they are used for, still, no building system can guarantee successful buildings; the quality of the final result, is always depended on the abilities of the designer.

CHAPTER 2

PROBLEMS IN THE PERFORMANCE OF PANEL SYSTEMS

Designers of buildings, architects in particular, are usually found in an awkward position when confronted with technological advances. Possibly due to education, possibly due to the orientation of the divided responsibilities in design and construction to specialized groups of professionals, architects are usually caught unprepared whenever a technological innovation enters the field of construction. The initial reaction is to find methods to use the new technology in proposing the same buildings as before the innovation was introduced. On the conventional use of technological advances, R. Bender writes:

...each new medium uses an earlier medium as its content (Bender quotes M. McLuhan)...and industrialized housing has taken the Victorian house as its model. [2]

Misusing, this way, the potentials of technology, the obvious method was to slice in parts what would be a conventional building, prefabricate the parts, and finally assemble them (figs. 5-7). Therefore, in the very popular form of panel

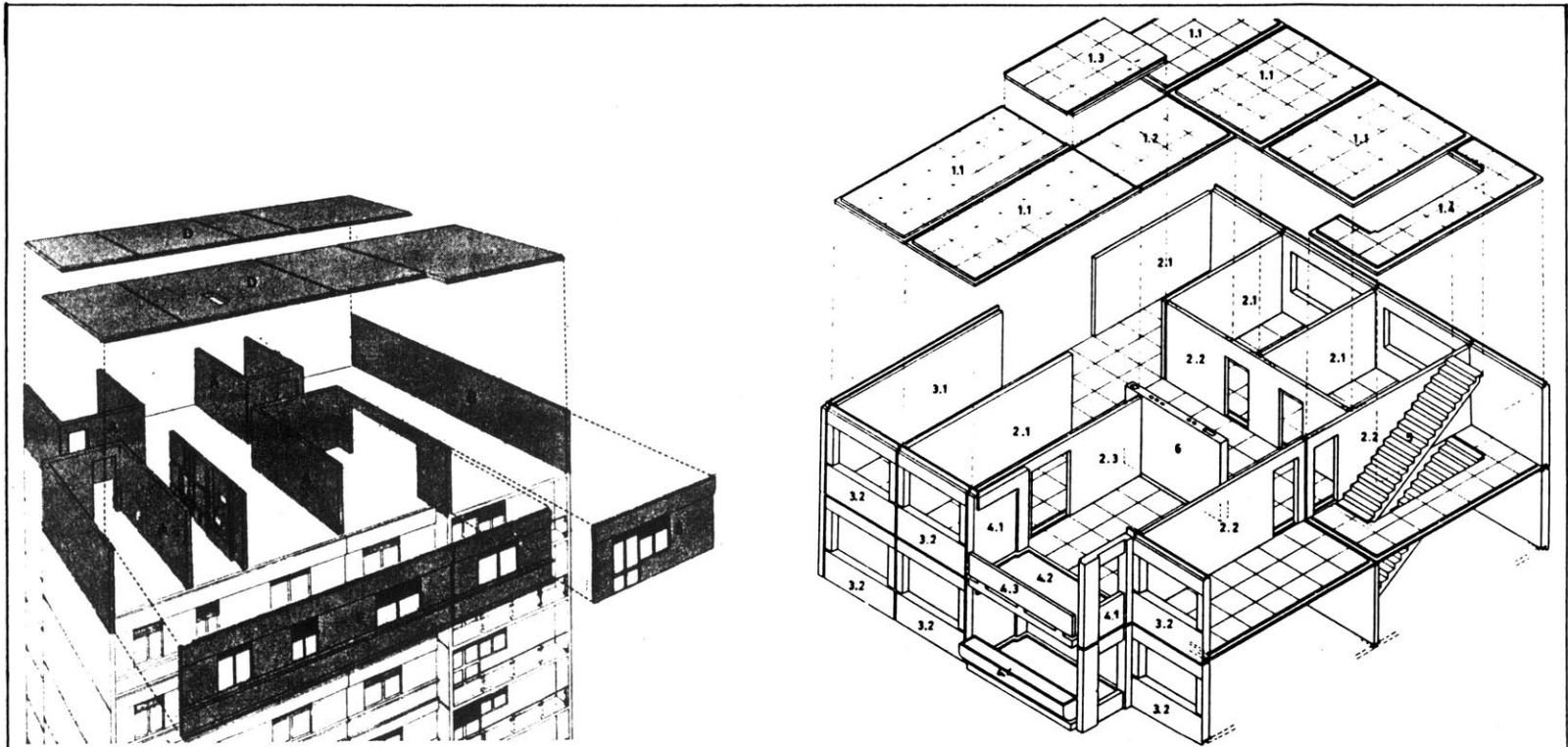

Figs.5&6 Conventional buildings divided in parts for prefabrication

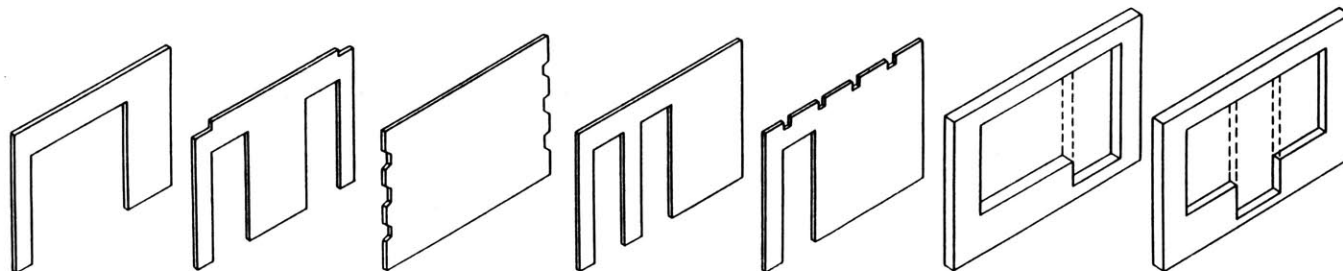

Fig.7 Typical elements of panel systems

systems, and the less used closed box systems, industrialization entered the world of construction. Initially the results were indeed beneficial. Relatively good quality buildings were constructed economically and fast, and immediate housing needs, as in the case of post World War II Europe, were, more or less, met. Today, however, our understanding of industrialized building is more mature than that of its early practitioners. We have the possibility to look back and study forty-year old prefabricated buildings, learn about their performance in time, and consequently, be better informed when designing new industrialized systems.

Looking in particular at prefabricated buildings which used concrete panel systems, two basic problems can be observed which are highly related to the scope of this investigation. The first problem regards the buildings themselves, specifically their incapability to be changed and transformed in meeting new needs and requirements. The second problem emerges, when rigid concrete panel construction systems become applied to contexts different from their originally intended one.

2.1. Resistance to Change and Diversity

The permanence of walls, characteristic of concrete panel and closed box systems, excludes any possibility of flexibility in internal spatial organization of buildings (fig. 8). In housing buildings, for example, the tentative resident, or future owner of a dwelling is restricted from participating in its design, since any change, will alter the prefabricated elements, and consequently ruin the economizing benefits of mass production of identical elements. Sometimes, however, it is unrealistic to talk of user's participation and input, simply because the users might be unknown while the building is designed or constructed. While in the case of development projects one will only buy if what is offered is what is desired, in the case of low income, or emergency housing projects, it becomes far too costly and slow to receive the user's input in any form other than labor. However, accepting the lack of flexibility in the phases of design and construction, does not relieve the above mentioned systems from the problems posed by their resistance to change. The issues of change and transformation become crucial in time, especially in

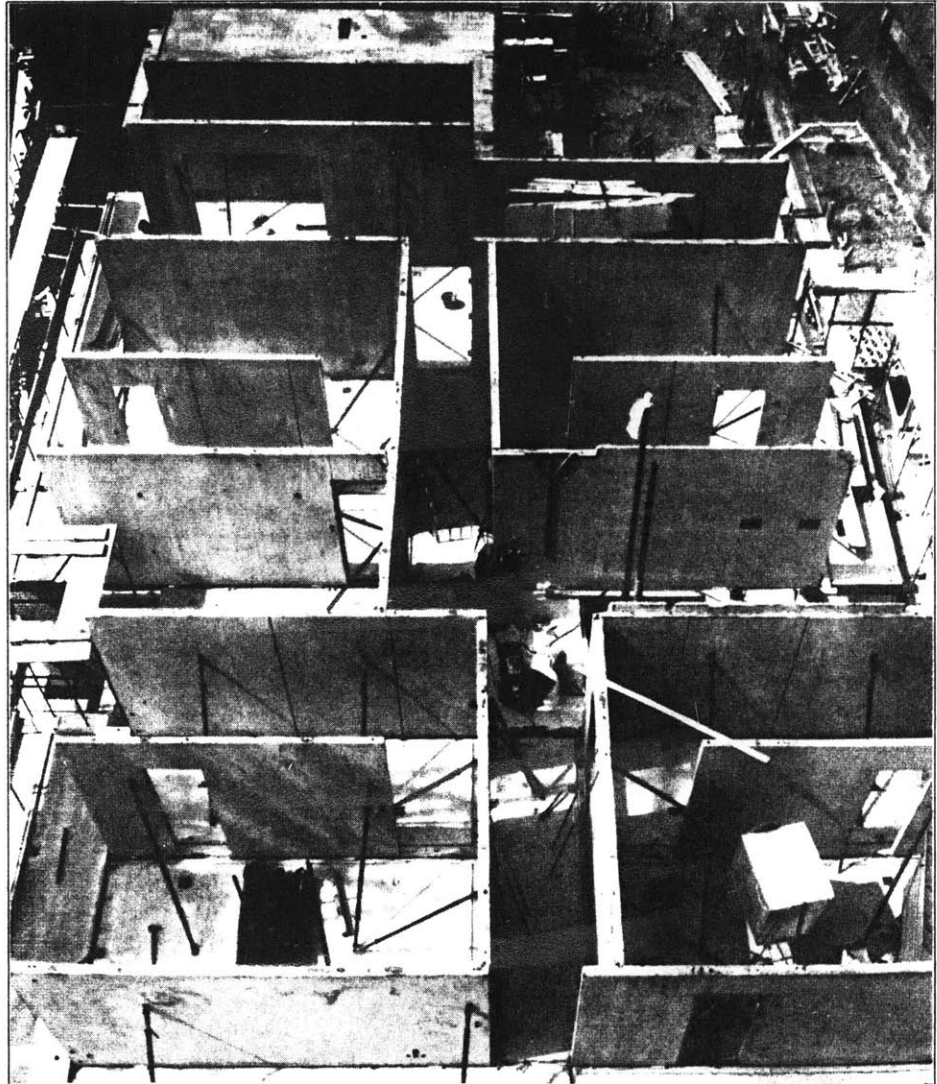

Fig.8 Permanent concrete panels of apartment building under construction

regard to housing projects. Eventually, families expand or contract, inhabitants change, standards improve; but due to the firmness of its elements, the building fails in adapting itself to the new needs.

Besides the issue of flexibility, which affects the inhabitants more than anyone else, other restrictions also emerge when panel or closed box systems are in use, which affect the builders themselves. Due to size and weight limitations of elements, such systems are incapable of generating large open spaces, which can then be made available to a variety of potential uses. As a result, companies which fabricate such systems are restricted to compete only within limited markets.

Paradoxically, even though flexibility might be most important in housing projects, due to the inability of panel and closed box systems to generate anything but small spaces, they become most suited for housing schemes, which are perceived statically, as accumulations of small identical spaces.

2.1.1. Technical Restraints of Panel Systems

In a concrete panel system, limitations of weight (for lifting), size (for transporting) and deflection, require that floor slabs be divided to small sizes, or at least, to narrow strips. Since every slab is supported by load bearing walls, the formed space between slabs and walls is dimensionally limited to the size of individual slabs, while its height is usually established at a minimum legal by the supporting prefabricated walls. In the resulting strictly divided apartments, the reinforced concrete walls which are all structural, cannot be later punctured, removed, or in any way transformed. Even when such walls do not bear loads, they still pose the same limitations if they are concrete panels, interconnected with the surrounding structure. This functional rigidity of panel systems is what renders them resistant to changes and diversity, and unadaptable to differing sites and contexts (if a panel system responds successfully to the conditions of its immediate context, since the system cannot be altered, it then must be unsuccessful in any differing context). Moreover, prefabricated concrete panel buildings are usually more expensive than they need to be.

Whether load bearing or not, concrete panels must contain a significant amount of reinforcement since they become subjected to various and sometimes unpredictable forces, during transportation and erection; and every panel is charged, not only with the price of the already costly cement and steel, but also, with the price of factory skilled labor hours, transportation and the expensive cranes. If a prefabricated concrete wall is used when loads do not need to be carried, money is wasted.

2.2. Panel Systems Applied to Diverse Contexts

2.2.1. Limited Applicability vs. Economy and Mass Production

Any design is developed within a set of constraints. A design solution tries to solve specific problems that are presented to the designer in the form of a program. Since the design of industrialized systems involves a problem solving methodology, just like any other process of design, it is evident that industrialized construction systems are not intended to be generic; instead, they are solutions projected to specific problems and specific conditions. Some problems and requirements

can be more general than others, as a matter of coincidence; but when they are observed and defined, this is done on regional bases. When it so happens, that two diverse locations share the same problems and requirements, then to apply industrial construction systems in the one, which were developed for the other, should result in no surprising effects.

To clarify somewhat this argument, it is useful to mention some requirements that might be defining the designer's course of action:

1. Immediate need for dwellings.
2. Requirement for low cost.
3. Availability and cost of materials.
4. Availability, cost and nature of labor.
5. Availability and cost of technology.
6. Topographical and geological conditions.
7. Climatic conditions.
8. Geometrical site patterns.
9. People's behavioral patterns and customs.

The listing can continue, but that would be of little

benefit. What becomes clear, when considering what influences a design solution, is that when the design solution is rigid, non transformable, non reshapable, non adaptable, then it can only respond to the specific conditions, of a specific site, and in a specific time frame. Such a method, however, of applying industrial products, in this particular case construction elements, negates the underlying principles of industrialization. Large quantities and repetition justify the fabrication of an industrial product. J. Habraken's argument on the relation of mass housing to mass production, parallels the point just made:

Mass housing looks to the single project only: each separate undertaking is different from the others. Every series is a new design made up from several new details and elements, and no factory can constantly adapt itself to each new series. Thus the factory method remains largely outside housing. [3]

A building system which involves prefabrication, requires a great deal of initial input, which takes the form of intricate design, purchase of equipment, construction of factories, management and labor familiarization with systemic work. When the initial work is completed, the machine of production is formulated (including all, people machines and organization) which can then generate output rapidly and efficiently. The more

the production, the less is the respective initial input cost per unit of output. For this reason, it is here stressed, that the mass production machine, in this case the construction element prefabrication plant, is resistant to change and adaptation of its product; every time a new product is required, the production machine must be altered, new input is required, and consequently, the factors of economizing are disrupted. It is therefore, in the nature of industrialization to ignore regional and contextual differences, the need for diversity among diverse contexts.

So far, two characteristics have been defined, which are natural to industrialization:

1. The mass production of repetitive elements is the rule of economy, therefore changing the produced elements is not possible, without additional cost.
2. Even though industrialized systems are designed in relation to specific regional conditions and requirements, again for reasons of economy, they result in being broadly used, also in areas where conditions and requirements differ significantly.

These realizations are mere characteristics of industrialization, not necessarily the evils of it. They are more like limits, a warning to the designer. The brick, or the 2x4 stud, also comply with those characteristics: they were initially designed for a specific purpose, but for reasons of economy, they have been mass produced, and consequently, applied to contexts foreign to their original. However, the flexibility in application, and adaptability of both brick and stud, to many different conditions, made them universally useful and successful systems. J. Habraken differentiates between mass production and the lack of flexibility experienced in mass housing projects:

...what matters is that mechanical production is by no means synonymous with mass housing, and that it would be possible to exploit the machine fully without ending up with mass housing. The machine in no way implies uniform dwellings and uniform ways of living: it has its own laws. [4]

The negative aspects of the above mentioned characteristics of industrialization, emerge when the systems designed and prefabricated are total and rigid; meaning, when the whole building is built by them, and nothing of it can be altered. Such is the case with closed box and panel systems.

2.2.2. Panel Systems Transplanted: The Case of Egypt

There are many examples of building technology transfers, from developed to developing countries. Even though this activity is a world-wide phenomenon, this investigation will only deal with the isolated case of Egypt. However, it must be noted that the problems observed and the solutions suggested, can be generalized to many developing countries.

When Egypt sought to take action in providing mass housing for its needy population, it lacked the technological means for fast and economical solutions. For assistance and examples, the Egyptian government turned to European sources. In the past, many European countries were confronted with housing problems, and they managed to develop appropriate building systems and technology, for their specific needs.

As mentioned earlier, the initial use of industrialized construction took the form of rigid concrete panels, and closed box systems. These systems and the buildings that were built by them, which stemmed from regional conditions valid in post World War II European contexts forty years back, is what the Egyptian representatives were presented with. The cause of many problems

that followed, was the inability of critical decision makers, from both Egyptian and European sides, to differentiate between universal and regional, and to understand how design constraints vary significantly from one location to another. A system and the resulting buildings that were designed to respond to conditions in 1945 France, for example, could not be transplanted unaltered to 1978 Egypt, with expectations of a free of conflicts fitting into local contemporary conditions (figs. 9 & 10).

What Egypt took from Europe, was not an understanding of the effects and methods of industrialized construction, but the industry itself. Instead of seeking the appropriate knowledge, with which they could design their own building evolution towards industrialization, they sought to get as close to the finished product as possible, with a purchase. But the purpose here, is not to criticize government policies. The lack of forecasting, and the desire to acquire the seemingly easy rather than the long-term valuable, are more of the rule rather than the exception, in bureaucratic policy making. The fact is, that Egypt (as many other developing countries), purchased the applied technology itself, rather than the technological know-how.



Figs. 9&10 Prefabricated housing buildings under construction near Cairo

After the factories were erected, and the equipment was all in place ready to start producing concrete panels, once more technical input needed to be imported; this time it was architectural and structural design. Since specialized personnel was not locally available, in order to design the systems and buildings that the purchased equipment was capable of producing, the experience of European consultants was essential.

The designs that were provided caused even more problems. Very small tolerances were assumed, which required great accuracy in production and assembly. Due to the nature of the panel system, skilled labor was essential, and the synchronization of production, transportation and erection departments was critical. Besides technical and organizational problems, most unfortunate was the design of the buildings themselves. No consideration seems to have been given to any design condition, characteristic of the region: climate, orientation, apartment layouts, building massing, site conditions, and the living patterns of the local people. On this specific issue E. Dluhosch writes:

...a major reason for the difficulties encountered could be found in the general 'design' attitudes which had been imported along with the factories, and which proved to be as closed and rigid as the resulting

physical product itself. [5]

The buildings that resulted could have made little sense in some European setting, but they definitely make no sense in the desert surrounding Cairo.

By now, many of these buildings have already been erected. The fragility of panels, combined with the bad state of local transportation systems and the general deficiencies in organization and timing, causes a 50% loss of elements (figs. 11 & 12). In addition, due to the unrealistic for local capabilities requirements for accuracy in production and other operations, before buildings are completed, consultants must already be hired, to reconnect panels which are in danger of collapse. Still, some do collapse.

The Egyptian experience described above, is a commonly shared phenomenon among many developing countries. Therefore, the resulting realizations are of broad significance.

Some critical issues have been raised so far, which lay at the base of the failure of prefabricated panel systems, in being adequately adapted to a diversity of contexts, especially to developing countries such as Egypt. Some of these issues involve

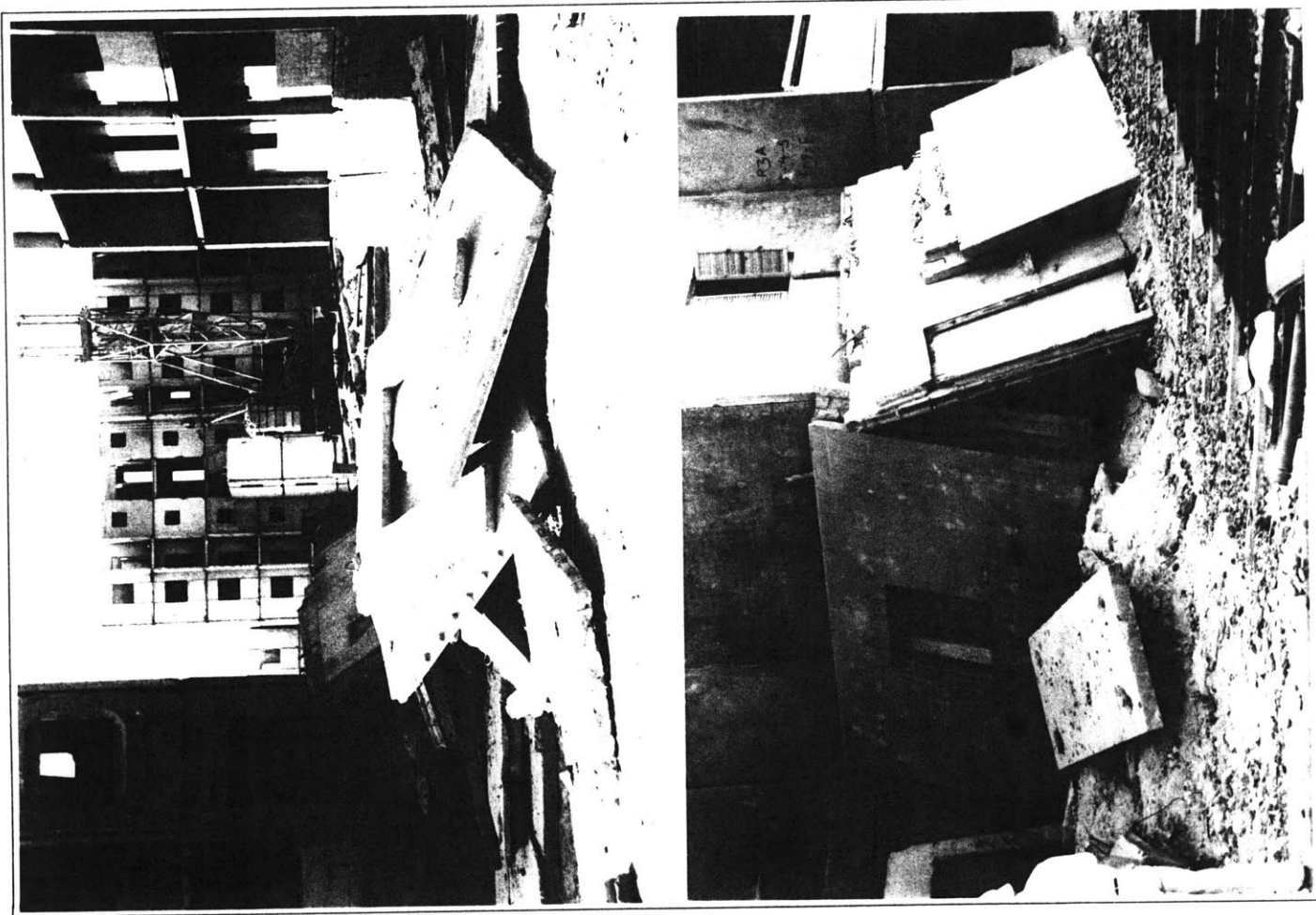

Figs.11&12 Damaged concrete panels accumulated on the construction site, Cairo

attitudes of people who control the logistics of technology transfer, while others, regard the transferred technology itself.

In summarizing the issues raised in regard to technology transfer, the following points can be noted:

1. Technological solutions such as panel systems, have limited applicability, since they can only meet requirements of their originally intended context. If they are to be transferred to other places they ought to be substantially adjusted. Otherwise, they should be avoided.
2. The purchase of equipment which can only be used for the fabrication of a non flexibly applicable system, eliminates most further options, since the final product is intimately related to the equipment that was designed to produce its elements.
3. Consultants to developing countries, must consider the specific conditions and requirements of the place of application before proceeding with structural and architectural proposals.
4. Decision makers from developing countries, must place emphasis in gaining a deep understanding of the effects and

methods of industrialization, in order to be able to define their country's evolution into industrialization.

CHAPTER 3

OPEN SYSTEMS: AN ALTERNATIVE TO INDUSTRIALIZED CONSTRUCTION

Initially, in this investigation, it was pointed out that the industrialization of construction processes through the prefabrication of buildings is, for many countries, an economic necessity and not an ideological or aesthetic issue. Further on, the popular panel systems and less used closed box systems were critically looked upon and found to be, at least, problematic if not inappropriate developments of building technology, especially in regard to housing. Two critical and more social than technical disadvantages, were found to be, their resistance in allowing for changes and diversity, and their unadaptability to differing contextual conditions.

As long as the economizing benefits of industrialization are sought, and especially when already existing factories and equipment must remain productive, industrialized building cannot be rejected. Other methods of building prefabrication have to be developed, which are free of the maladies of panel systems.

Before proceeding, however, with any proposals, it would be helpful to briefly emphasize the fundamental stigmas of panel systems, from a technical viewpoint.

3.1. Introduction to Open Systems

3.1.1. Definition

It is necessary to design buildings that use industrialized construction methods, buildings which can be transformable, which can accommodate a variety of layouts, and which can be applied to a diversity of contexts.

One answer to such requirements can be found in "open systems". An open system, can be here defined as a system which differentiates between elements which need to be permanent and elements which do not need to be permanent, where the non-permanent elements have various possible locations, are not needed to stabilize the permanent ones, and thus their material composition can be undefined (fig. 13).

The most obvious open system which does away with restrictions posed by panel systems, would be an open structure

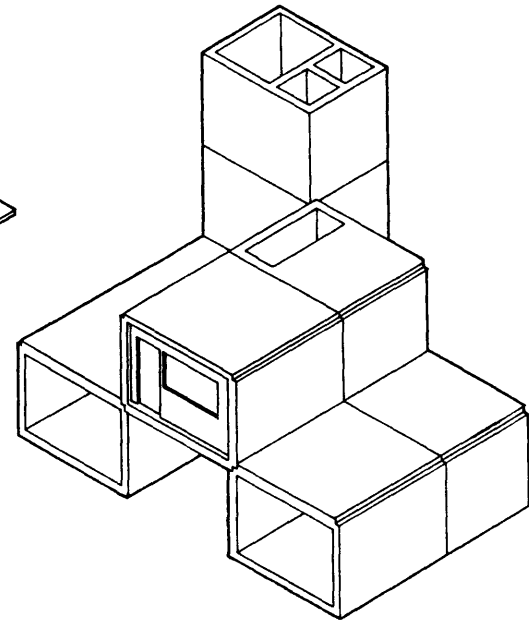
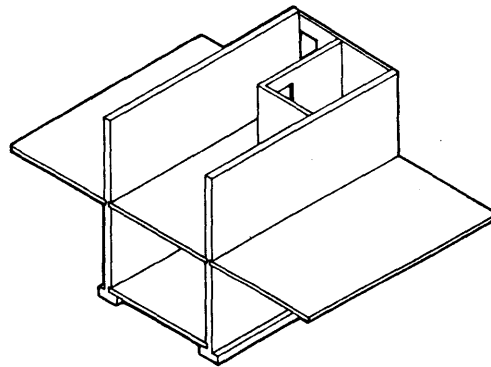
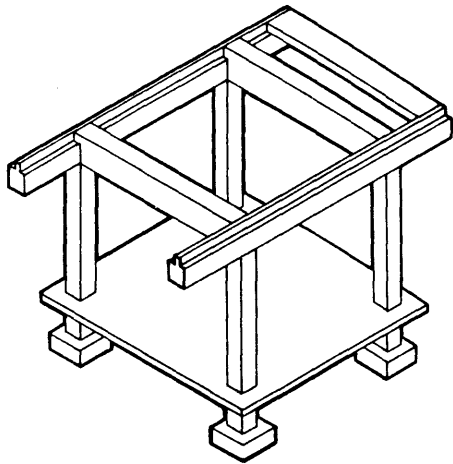

Fig.13 Schematic demonstration of the principle of open, panel and closed box systems

of large-span slabs carried by minimum vertical supports. When all walls are relieved from load, their position, material, even their presence, can be irrelevant to the strength and stability of the permanent elements (figs. 14 & 15).

In such an open system, where the differentiation between permanent and non-permanent elements can be defined as a differentiation between structural (slabs, columns and possibly beams) and non-structural (exterior and interior walls, bathrooms, kitchens, finishes, etc.) elements, the role of the prefabrication plant has to be redefined as the provision of building platforms upon which the building of dwellings can occur. Introducing the concept of "supports", J. Habraken states:

We must make constructions which are not in themselves dwellings or even buildings, but are capable of lifting dwellings above the ground; constructions which contain individual dwellings as a book-case contains books, which can be removed and replaced separately; constructions which take over the task of the ground, which provide building ground up in the air, and permanent like streets. [6]

The dwellings contained in the supporting structure, can be free of the sameness of mass production; they can be as ephemeral as a tent, or, as ever-during as a fort.

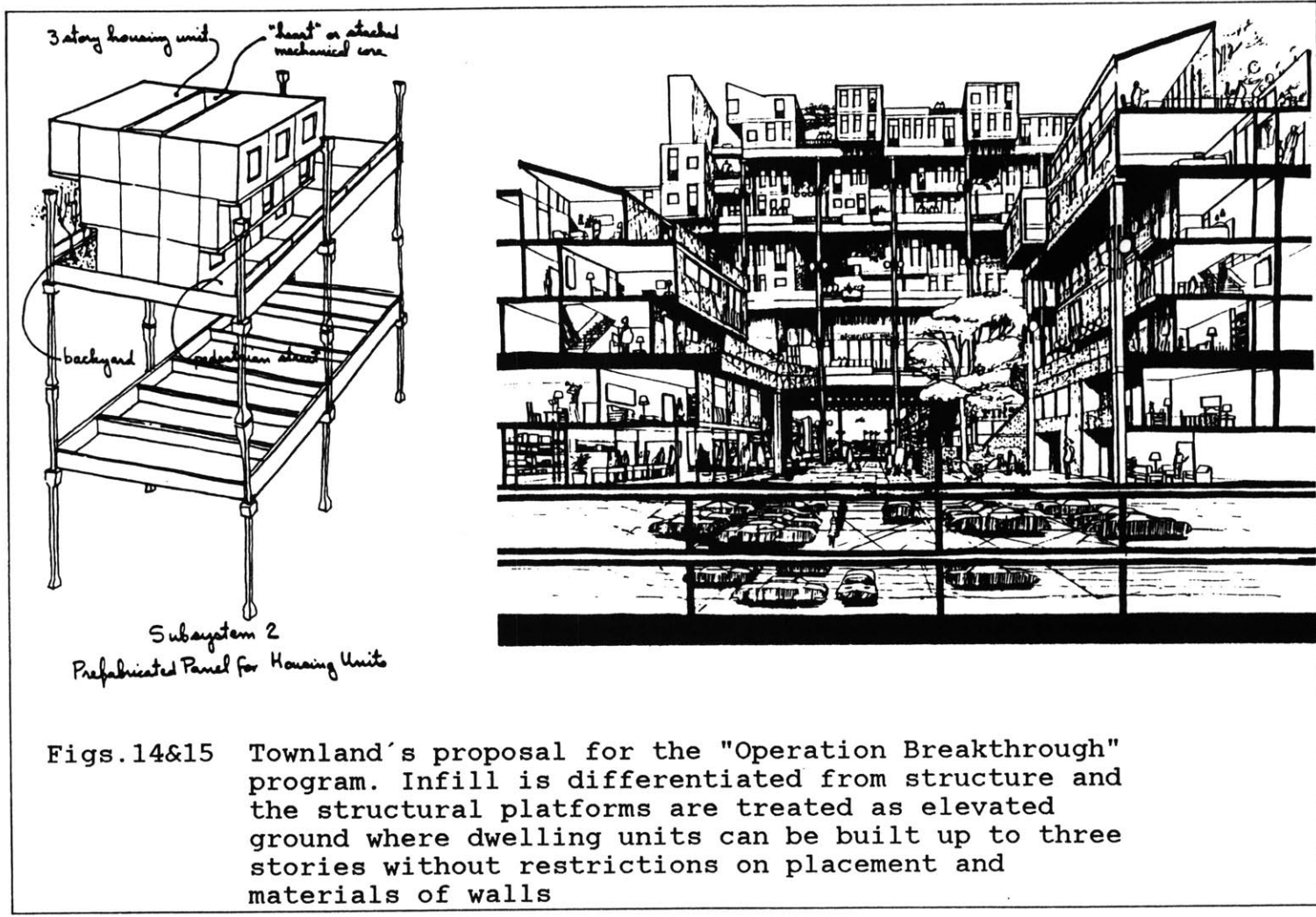

3.1.2. Advantages of Open Systems over Panel Systems

Following, some benefits of open systems over panel systems, are listed:

1. Reduction of costs:

a. The use of prefabricated elements, made of the relatively expensive cement and steel, is restricted to only structural components.

b. The highly costly crane hours per building are reduced.

c. Less, skilled factory workers are needed, while more not so skilled labor must be employed on the site (beneficial to developing countries' economies).

d. Factory operations can become more efficient and the workers more productive, when dealing with few types of elements and operations, rather than many.

2. The prefabrication factory can compete in more areas of the construction sector, besides housing. Unlike the resulting small spaces in panel buildings which call for housing exclusively, the large empty platforms of the open system can accommodate many types of uses.

3. The unspecified location and material composition of non-structural elements, allow for diversity of layouts within one building, and make possible the input of users in the design and construction processes of individual dwellings.

4. Changes in the status of the user can be paralleled by possible upgrading and transformations of individual dwellings.

5. The producing, transporting and erecting operations are significantly simplified, reducing the possibilities of errors:

a. The reduction of the number of elements necessary to erect the structure, results in a reduced number of joints (possible failure points), thus improving the building's structural behavior.

b. The reduction of the types of elements results in a reduced number of types of forms, and simplifies all operations and their coordination; it also results in better familiarization of the worker with the work, easier inspection, and consequently, better quality of the product.

c. The increase of the number of produced elements of a given type allows for more efficient production methods.

6. With open systems and the differentiation of structural from non-structural elements, the shift can be achieved, from mass-housing to dwelling; from blocks of identical, impersonal cells, to rich clusters of individualized environments.

3.2. Open Systems Applied: Conditions and Requirements

For any such change to occur (meaning from closed to open systems), first of all, investors, clients and factories must be convinced that the economizing benefits of prefabrication are not undermined when the use of prefabricated concrete elements is limited to structural components of buildings.

The notion of producing and erecting elements for a partial building (structure in this case), rather than a complete one, does not necessarily mean slower construction and less revenues for the prefabrication plant.

In countries where there is high construction activity and a lack of housing, as in most developing countries, the erection of a part rather than the whole, can only lead to the earlier erection of another part. If, for example, a factory can remain active by manufacturing three elements rather than fifty, it is likely that its revenues will rise rather than drop, even if it does not undertake the completion of buildings. Furthermore, if the factory's role is restricted to the fabrication and erection of such anonymous platforms, as mentioned earlier, its market

will be likely to expand, since many other types of uses besides housing can be accommodated on empty building platforms. It can also be assumed that the mass production of few basic elements will lower the operating costs of the factory, so it can provide low cost, high quality structures, to meet an ever-increasing demand.

If the non-permanent elements are to be built traditionally, with bricks, blocks, mud, or whatever tradition provides, the duration of construction can be longer than that of the all prefabricated building, without necessarily resulting in higher costs. If traditional materials are cheaply available and commonly used, their construction method should be common knowledge, thus allowing the employment of, less expensive than factory workers, unskilled labor. However, the reduction of the required crane hours for the erection of elements on the site, might be the greatest financial benefit.

The notion of differentiating structure from all else, does not exclude the possibility of technologically more advanced than brick laying methods to be employed for the construction of walls (fig. 16). Light-weight frames and panels, possibly similar in

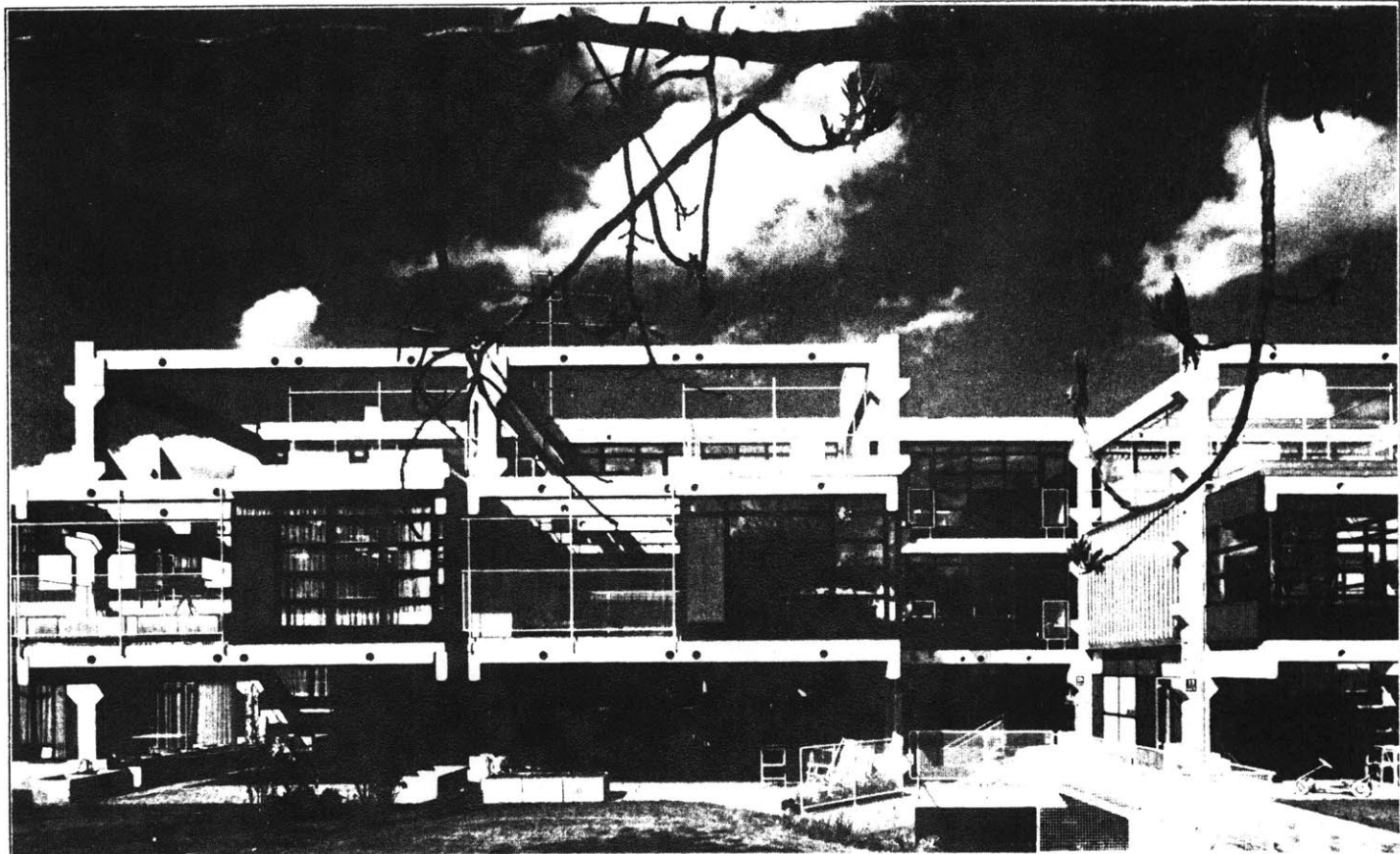

Fig.16 Structure is differentiated from all walls. The walls are prefabricated light-weight panels and their position is variable (Arch. O. Steidle)

principle to the stud and gypsum wall-board system, can be of relatively low cost and rapidly erectable. One can also consider completely industrialized and mass produced light-weight component systems, which, like kits of parts, can be found in the open market as complete packages. Such industrialized light-weight component systems, to be of any benefit above panel systems, must be designed to offer numerous diverse assembly configurations, with easy connections. If so, the possibility arises for the actual dweller, with some instruction, to shape and construct his own dwelling according to his liking and needs, within a purchased or allocated area of structural platform.

One issue not yet discussed, is the adaptability of open structural systems to a diversity of contexts, or a variety of sites. Even though structural platforms, as described earlier, can offer great flexibility in terms of shape, material, method of construction and transformability of what they support, the permanent structures themselves can prove to be only appropriate for the specific site for which they are destined. However, open structural systems are most useful and most economical, when they can be applied to diverse contexts and be accommodated on various

differing sites.

In the previous chapter, the point was made, that industrialized mass produced systems, usually result in being broadly used, even beyond the context of initial intended application, since costs of production are reduced and revenues increased with greater mass production of identical elements; and in free economies, where profit guides production, the spread of a seemingly successful industrial product is guaranteed.

By accepting this economy based phenomenon, the designer is confronted with the challenge to develop structural systems that can be adaptable to a variety of sites. How can a structural system be well received by both flat and sloped sites? How can it parallel both regular and irregular street patterns? How can it form all clustered, linear, radial or circular building configurations? How can it do all these things without extra costs?

The challenge must be met. The answer to these questions, however, cannot be found within the realm of theory. It is here believed, that concrete answers to such concrete questions can only be searched for on a technical level, after rigorous design

and investigation. Hopefully, this is achieved in the following chapter. What can be stressed at this point, is that the question of adaptation to diversity must be faced by the designer, independently of the desired immediate application and given program. On this issue E. Dluhosch writes:

In systems design, one does not deal with the design of the unit per se, but with testing the capacity of both technology and architectural space to accept a given range of design variants within clearly defined parameters of agreed upon spatial norms. [7]

A system must be checked against various programs and possible sitings, it must be neutral and non-specific, if it is to be successfully applicable on a broad level. The structure will become a building with identity, a specific contributor to the regional fabric and an integral part of it, only after its empty platforms are subjected to the diversified act of dwelling.

CHAPTER 4

AN OPEN STRUCTURAL SYSTEM DEVELOPED: SLAB-COLUMN SYSTEM

In the previous chapter, the benefits of open systems over panel systems were described. The idea of large-span slabs (building platforms) carried by minimum vertical supports was entertained as an abstract version of an open system.

In this chapter, a developed structural open system is presented, the Slab-Column System, which tries to stand up to the performance criteria set in the previous pages.

4.1. Evolution

The Slab-Column System was developed as a part of the contribution of the M.I.T. Advisory Group (Prof. E. Dluhosch, Prof. W. Zalewski and F. Panayides) to the Prefabricated Houses Co. of Cairo, Egypt. The initial requirement posed to the M.I.T. Group by the company, called for the improvement and simplification of a given panel system which was designed by a

European firm and was performing poorly in the Cairo low-income housing buildings. The plans of the buildings were prepared by the Ministry of Housing in Cairo, without any prior consideration given to method of construction.

A series of improved and simplified panel systems proposed by the M.I.T. Advisory Group did little in reducing the cost of buildings, even though the structural behavior of buildings was greatly improved. The apartment layouts could not be bettered since the client did not allow alterations of the given plans. To construct such plans with rigid panels would also eliminate the possibility of any future upgrading of apartments.

The main concern of the company was the reduction of costs; and the only way to reduce costs also assured better living environments. It was required that the necessary amount of the relatively expensive cement and steel be reduced, and prefabricated reinforced walls be substituted with walls of cheaper materials. In responding to this requirement the M.I.T. team took the initiative of designing frame systems, where all walls are non-structural.

The company would be doubly benefited: not only the amount

of expensive materials would be reduced, but also, structures could be erected which could be adaptable to more functions besides low-income housing.

The Slab-Column System emerged from the study of frame systems. However, usually frames have one limitation. That is their lack of flexibility in being adapted to diverse sites, and the incapability of frames in composing various geometrical configurations. The interdependency of structural bays and the need for alignment of beams and columns, define a basic building configuration, linear or block-like, with orthogonal structural relationships (fig. 17). Any diversion from the regular block building requires special elements, higher costs and new designs.

4.2. Slab-Column System Description

In the Slab-Column System each bay is independent. One bay alone can be seen as a stable structure in itself (dwg. 1). Therefore, the arrangement of bay-slabs is not limited by structural requirements of interconnectedness and alignment, thus allowing for various possible building configurations.

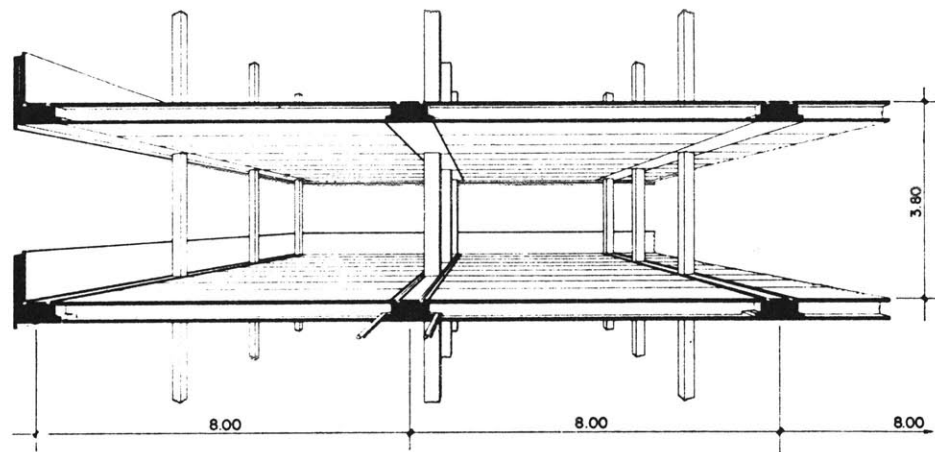
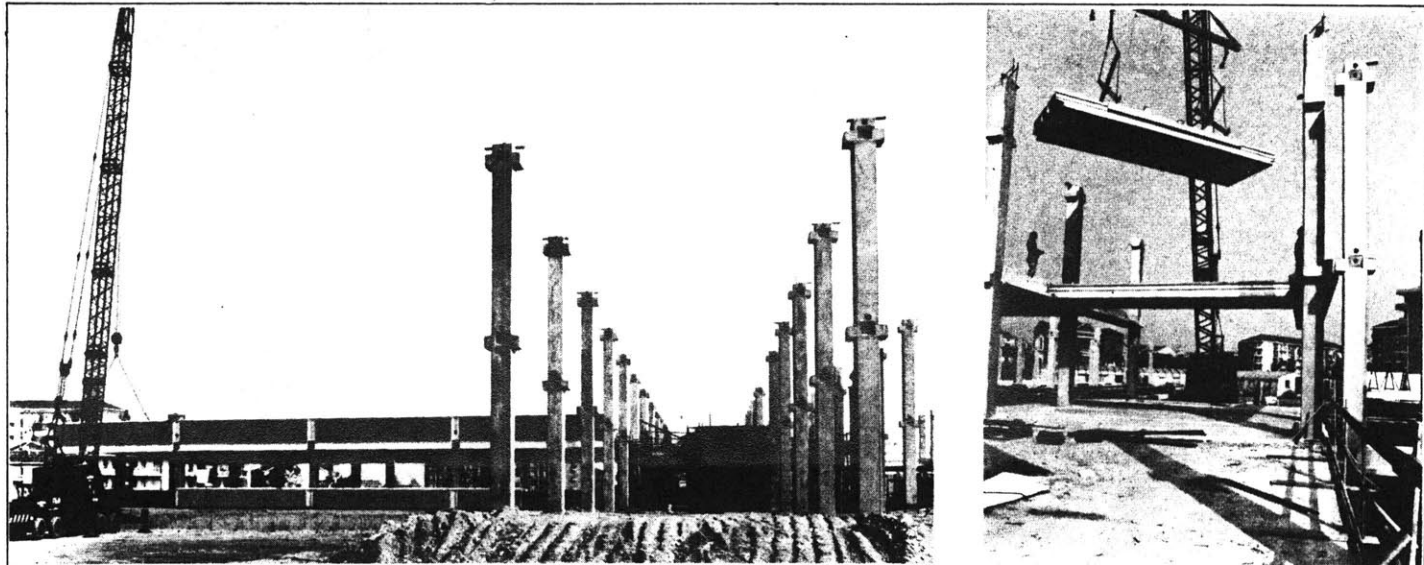

Fig.17 Example of a frame system. The need for alignment of elements allows only limited variability of building form

Unlike panel systems, the Slab-Column System does not form complete buildings, it is only a structural system. When the structure is erected, large platforms are provided with minimum vertical supports, upon which one can built freely with any material.

The system is composed of only two elements: a slab, and a column which is made of two parts.

Each slab is supported along its center axis by two columns which are spaced 7.20 meters apart (axis to axis). The slab was designed to reach in weight the practical limit of crane capacities, in an effort to make efficient use of facilities and reduce the number of building components. The slab measures 2.70x9.00 meters (dwg. 2). About 1.50 meters of its length is given to one side, beyond the column and it acts as a cantilever. The slab is ribbed. Only a ribbed slab without ceiling could be as large without exceeding the weight limits. The ribs act as beams and stiffeners. They transfer the loads of the slab to the columns. Four ribs run along the length of the slab, and three wider ones run along its width.

The stability of the one-slab structure is primarily due to

the shape of the columns. The section of a column resembles a "T". The "T" shape offers stability with relatively little amount of material, compared to square or circular sections. The two parts of the "T" column can be called "flange" and "web". The web, which is column part C-1, faces the opposite column, while the flange, C-2, is perpendicular to the web, on the opposite side of the span (dwgs. 3 & 5).

Column part C-2 (flange) rises from floor to ceiling. Its profile also resembles a "T". The horizontal parts, left and right, are arms which support adjacent slabs. Sometimes columns with one arm can be used, or even plain columns with no arms (dwg. 4). This depends, on whether the adjacent slabs are carried by their own set of columns or not, and on the location of the column, whether it is at the end of the building, next to a stair, or in a central position. The vertical part of column part C-2, is divided in two, resembling a pair of legs. It is designed in such a way so the two parts of the column, C-1 and C-2, interlock (dwgs. 6 & 10). Part C-2 is lowered over and sits on column part C-1. Correct placing is assured by a pin and pipe joint. Once positioned, C-2 does not reach the slab underneath.

It remains two centimeters higher so it can be levelled with the use of permanent concrete wedges.

From the top of C-2 two reinforcement bars stick out. They are threaded through two 10 cm in diameter holes on the slab, when the slab is lowered to place, and they are finally welded to steel angles embedded on the sides of the next C-2 positioned directly above (dwgs. 7 & 9). The 10 cm diameter holes on the slab are filled later with concrete. This connection assures continuous vertical reinforcement of the structure.

At the ends of the arms of C-2 are loops of reinforcement which coincide with notches on the sides of slabs. When two slabs are attached and aligned, the two notches form a rectangular container, with the top of the arm at its bottom and with reinforcement loops from all elements inside it. A wet joint cast there, solidifies the connection between columns and adjacent slabs. This connection is specially effective when only every other slab is supported by its own set of columns, and intermediate slabs are supported on edges of arms.

Column part C-1 is one meter longer than part C-2. It is so because it penetrates through a hole on the slab (and foundation)

and sits on the column underneath (pin and pipe joint), one meter down from the top of the slab (dwg. 8). Part C-1 is installed first, and its penetration allows for precise positioning. In addition, the difference in level of connection of the two column parts gives better structural continuity to the column and more resistance to bending.

The correct placing of the 7.75 ton slab on the columns is assured by two devices. The two 10 cm in diameter holes which occur on both extreme transversal ribs must be first placed over the reinforcement bars which project from the top of column parts C-2. Precise placing is confirmed when the 5 cm deep recesses on both sides of the underside of the slab are fitted over the 25x25 cm square upper extension of column part C-1.

On the inner side of this upper extension of C-1 there is a groove, 5 cm deep which runs down up to where the element widens. This groove serves as a channel for the placement of mortar in the connection between the two column parts. Without this groove, the 3 cm tolerance between elements would not suffice for the placement of mortar in the joint, unless the mortar contained more water than the acceptable amount.

The stairs that service the Slab-Column System buildings are also prefabricated. They are designed to be structurally independent. They can be placed within the building, attached to it, or clearly separated from it. The stability of the stair tower is not depended on connections with the main structure of buildings.

Each run of steps with half of the top and bottom landings form one prefabricated element. This element when rotated 180 degrees, becomes the second run of steps (and the landings are completed) (dwgs. 11 & 12). Two runs are needed for the height between two floors to be covered. The two stair elements are carried on walls at the two ends, beyond the landings (dwgs. 13 & 14). The stair elements bear comfortably on the walls, extending 10 cm beyond them. Holes in the landings which measure 10 cm square coincide with reinforcement bars and loops which extend above the top of the supporting walls. When the stair elements are placed, the reinforcement bars from the wall are threaded through the holes in the landings. The joint is then filled with concrete. With this kind of hole and re-bar joint, correct placing of elements is controlled, while the loops that protrude

from the top of walls are also used for lifting the elements by cranes.

The description of the Slab-Column System in its basic form is here concluded. The flexibility the system offers must be understood on two levels:

1. Possible variability of internal configurations; undefined position and material composition of all walls.
2. Adaptability to diverse sites and contexts; freedom in geometric composition of buildings.

So far, what is evident is the possibility of variable internal configurations. The adaptability of the system to differing geometrical site conditions is based on the independence of structural bays, and on the variable shape and size of elements, which is achievable through a method of subtraction from the basic shapes of elements that have been presented. Before, however, an explanation and a demonstration of the adaptability of the system to diverse sites is undertaken, a comparison will be made between two housing projects: buildings

currently constructed by the Prefabricated Houses Co. via the use of their initial panel system, and similar plans which use the Slab-Column System.

4.3. Slab-Column System Compared to Panel System

The reinforced concrete panel system that was initially employed for the construction of low-income apartment buildings by the Prefabricated Houses Co., continues to be used despite the numerous improvements proposed by the M.I.T. Advisory Group and the structural problems and economic inefficiencies it poses.

A brief comparison will be made of the performances of the panel system and the Slab-Column System. As mentioned earlier, both building outline and apartment layouts have been predetermined by the Egyptian Ministry of Housing. The presented plans which use the Slab-Column System do not represent the M.I.T. team's preferred design solution. They are adapted to the Ministry's requirements and are similar to the plans of the buildings actually constructed by the Prefabricated Houses Co.. Nevertheless, alternative plans, even though generally similar to

the required ones, are still provided (fig. 18 & dwgs. 15-17).

Since the two systems are applied to similar buildings which respond to identical requirements and context, a comparison of specific technical criteria should be justified. The comparison is based on criteria of economic and structural nature: amount of reinforced concrete, number of elements, number of types of elements and their fragility, and joints and tolerances.

4.3.1. Amount of Reinforced Concrete

It has already been concluded that a significant reduction of costs can result from a reduction of the necessary amount of reinforced concrete. Cement and steel are expensive materials when compared to bricks, blocks, gypsum boards or mud bricks. All walls of the panel system are load bearing reinforced concrete panels which cannot be replaced with walls of other materials of lower resistance to loads. The panel system uses 0.4 cubic meters of reinforced concrete per square meter of floor area. Of that amount, only 0.15 cubic meters are used by slabs. The other 0.25 is used by walls. In the Slab-Column System, slabs use an equal amount. The columns, however, only add 0.05 cubic meters, raising

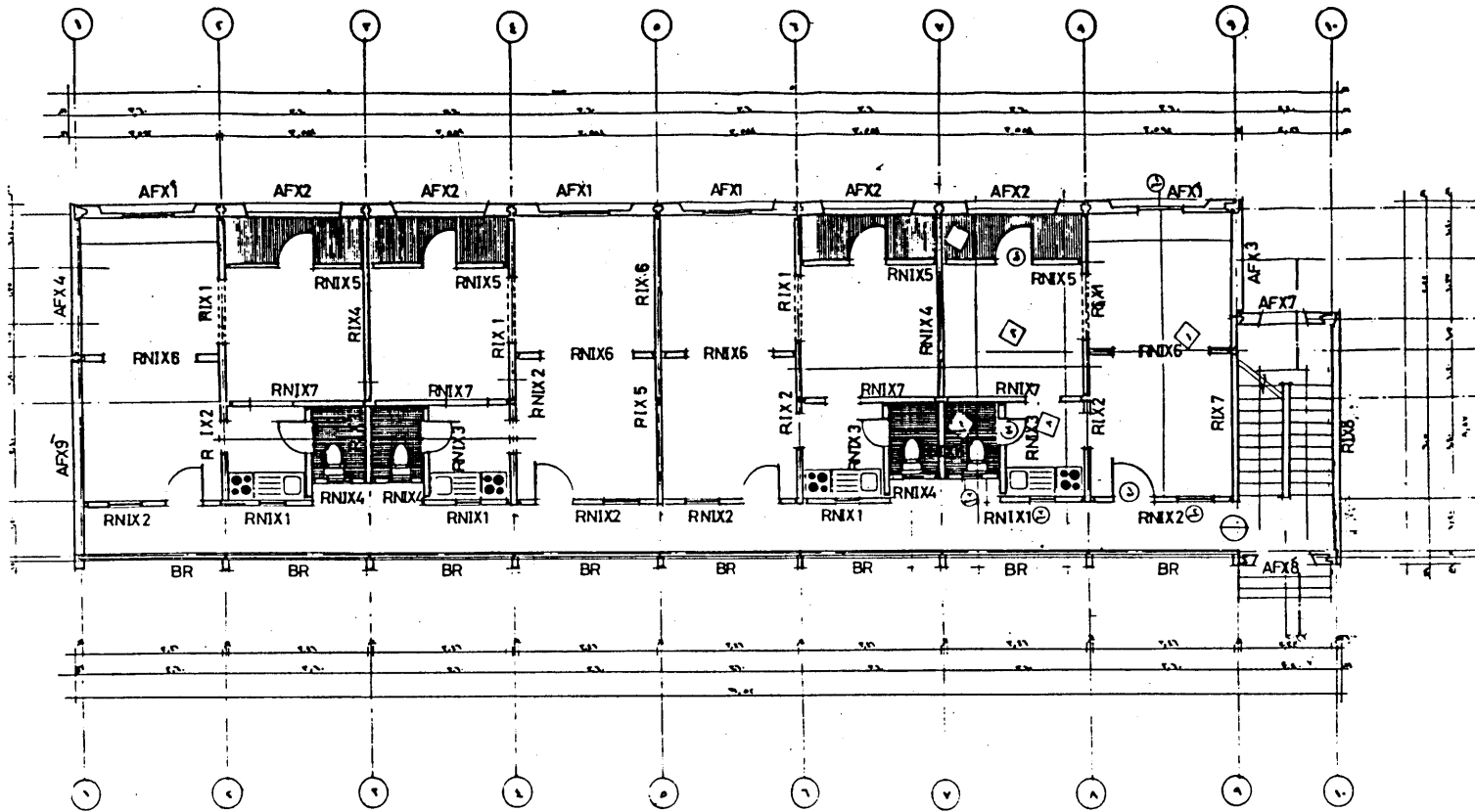

Fig.18 Typical plan of low-income housing buildings constructed by the Prefabricated Houses Co. with the use of a panel system

the amount of reinforced concrete to a total of 0.2 cubic meters. In addition, the Slab-Column System requires 34 linear meters of non structural wall per apartment. While the non structural walls can be built of any cheap material without resulting in high costs, the 50% reduction in reinforced concrete brings a significant cost reduction.

4.3.2. Amount and Variability of Elements

The erection of one unit of the panel building requires seventeen elements. The equivalent number of elements for the Slab-Column building is eleven. The fewer prefabricated elements of the Slab-Column System assure both lower costs and safer structure. With fewer elements, less use of trucks and cranes is required, while factory production space is saved and the number of needed factory equipment is decreased. In addition, as a consequence of the lowered number of elements, both structural discontinuities and number of joints -possible failure points- are reduced.

Much more significant than the reduction of the number of elements is the reduction of their types. Of the seventeen

elements per unit of the panel system, no two elements are identical. In total, the system uses thirty-seven different types for the erection of one building, plus eight additional types for the stair and stair enclosure. In contrast, the eleven elements per unit of the Slab-Column System are of only three types: one slab and two column parts. Three additional elements are used for the stair and stair enclosure. Of the three main elements, the slab (7.75 tons) reaches in weight the limit of the company's existing cranes, while each of the two column parts weighs less than 700 kilos. The lightness of the column parts allows for a small crane of lower cost to be employed ahead of the large crane in erecting the columns, thus speeding the whole erection and assembly operation.

The economizing effects of such a dramatic reduction of types of elements from forty-five to six, are further intensified when the reduction of the types of casting molds in the factory and the simplification of all operations are considered.

The presence of door and window openings, grooves and fine details of edges, renders the elements of the panel system highly fragile (fig. 19). Fragility, combined with mishandling during

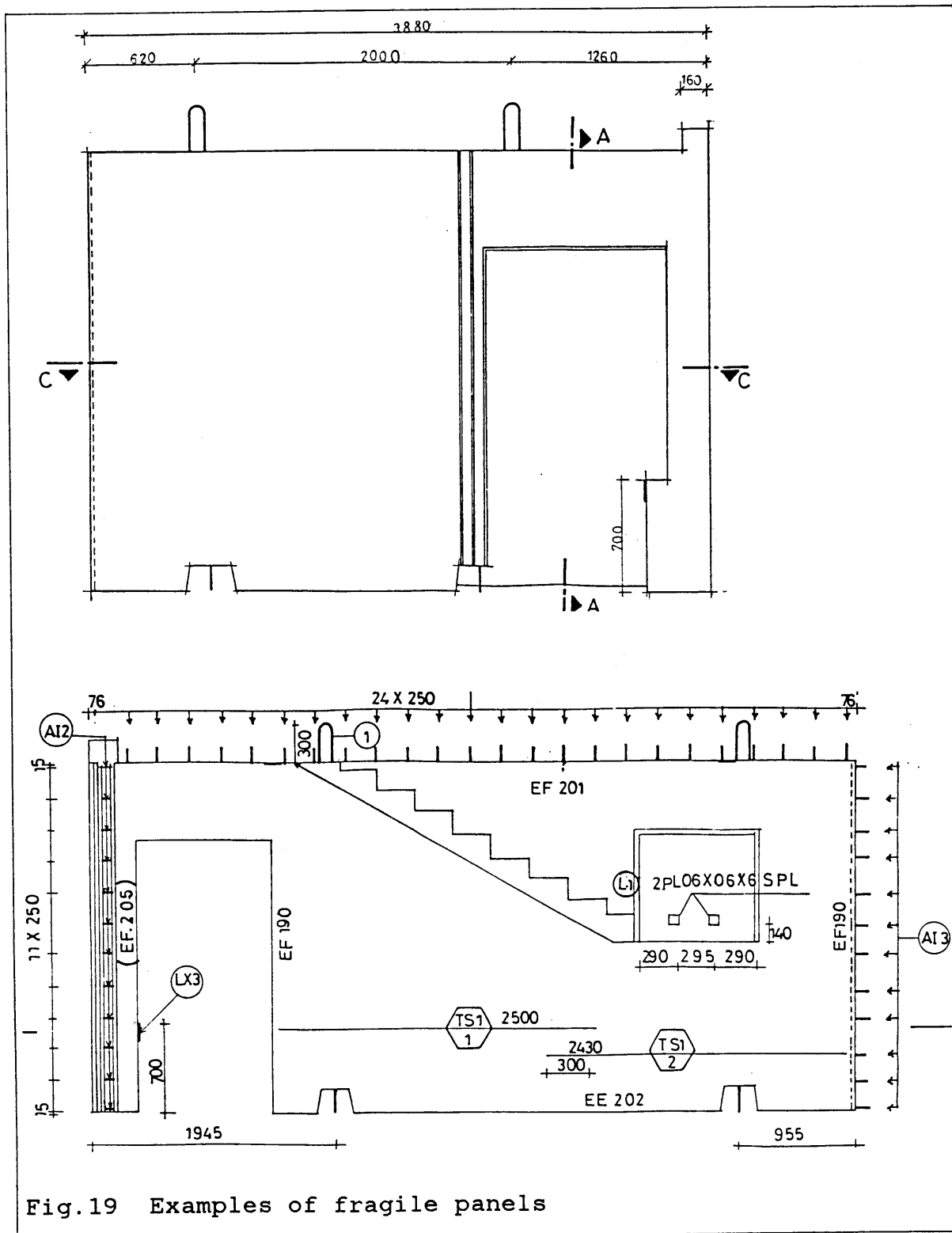

Fig.19 Examples of fragile panels

transportation and erection causes breakages. Because of the great number of types that arrive on the site, many of which have non clearly noticeable and yet important differences, when one panel is damaged it can easily be erroneously replaced with a seemingly similar panel of a different type. When such errors occur, the designed connections cannot be made, on-site improvisation takes place, and the stability of the entire building is left to chance.

The elements of the Slab-Column System are not fragile. In case, however, an element does break during erection, there can be no confusion as to its replacement.

4.3.3. Joints and Tolerances

The joints of the panel system are numerous and complex. Ten different joints are designed for the connection of the panels (stairs excluded). More problematic than their number, is the level of accuracy the joints require in the assembly and production of panels (figs. 20 & 21). The joints are linear, connecting the complicatedly detailed edges of panels. They rely on precise spacing between panels and on excellent condition of

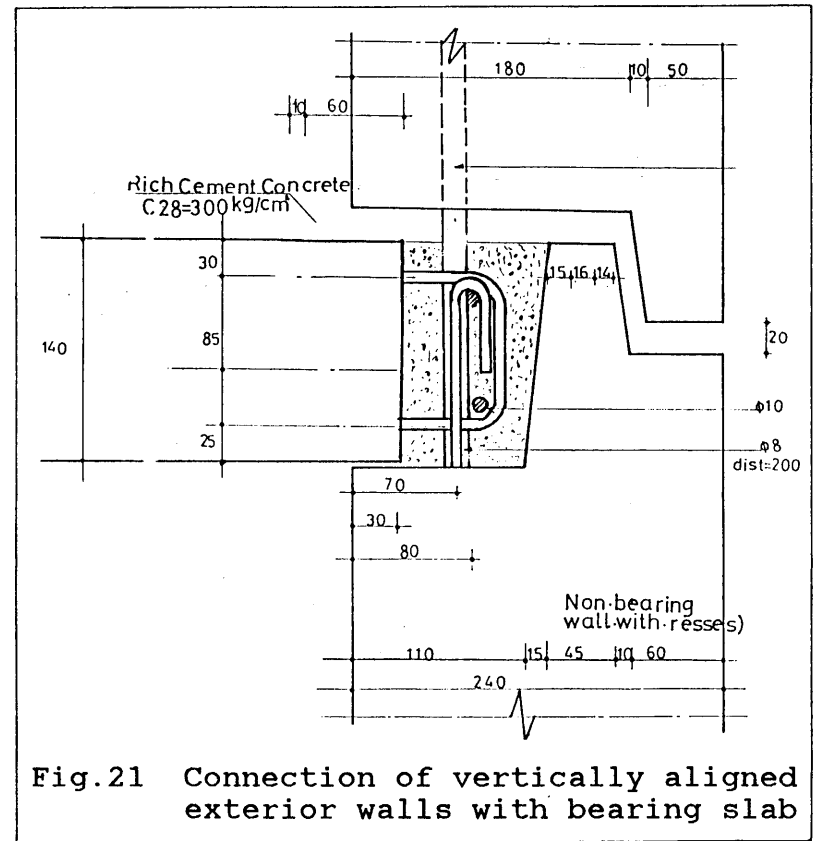
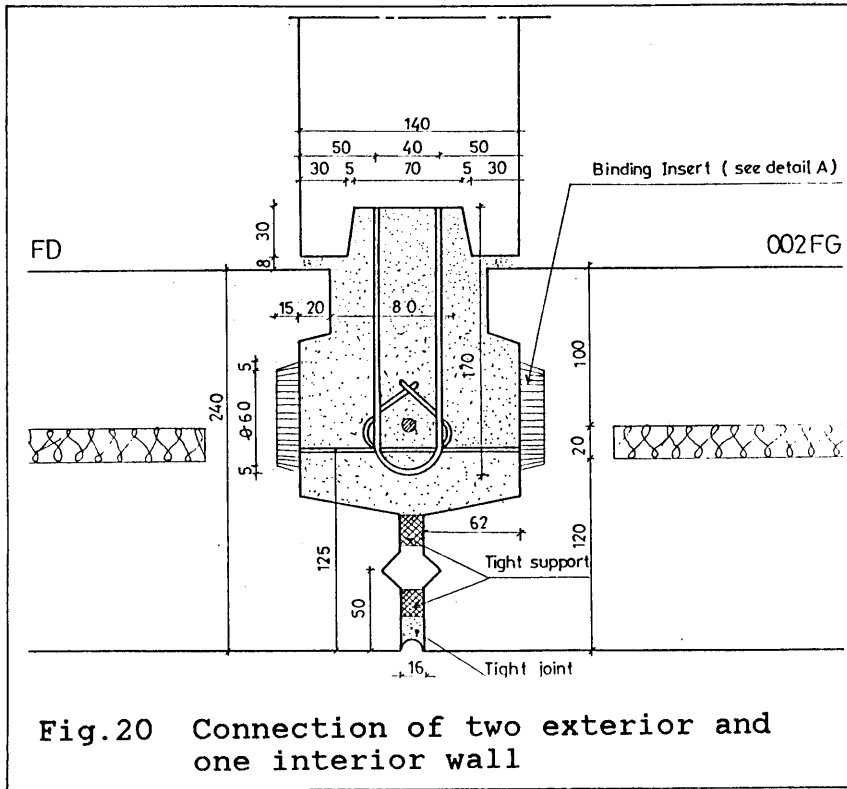

edges.

The slabs, for example, are designed to bear on only 4 cm on top of the exterior walls, while the exterior walls sit directly on top of each other, overlapping the edge of the intervening slab. Steel loops which protrude from the edges of the slab and the supporting wall are expected to overlap allowing for the insertion of a tie bar, while a protruding bar from the top of the wall underneath is expected to enter a narrow hole on the base of the bearing wall above. If the exterior walls are not perfectly vertical, or if a slab happens to be a few centimeters short, or even if any edges of panels are chipped, then the elements might not meet in space, leaving aside needle and thread relationships of loops and re-bars. The very small tolerances and general accuracy levels assumed, are far above local practices.

The Slab-Column System uses only one structurally critical joint. This is the connection of vertically aligned columns and the intermediate slab. This joint, however, does not pose any problems of accuracy, since the holes on the slabs through which the re-bars that protrude from the top of the columns are threaded, are 10 cm in diameter. On the contrary, the re-bars act

as assembly guides, assuring the correct positioning of both slabs and columns to be assembled above.

This comparison was only based on technical criteria in order to reveal the great extent to which costs can be reduced and operations can be simplified by the substitution of a typical panel system with the Slab-Column System. These benefits, which constitute only a part of the advantages of the proposed system, can possibly be shared by other frame systems as well. The uniqueness of the Slab-Column System lies in its flexible adaptability to diverse functions and sites.

4.4. Adaptability of the Slab-Column System to Diverse Sites

The Slab-Column System was initially developed as a response to the requirements of the Prefabricated Houses Co.. However, in designing the system, a broader context of application was assumed. Adaptability to diverse contexts and sites was thought to be important for the system's success, since industrialized construction systems do become broadly applied despite initial

requirements. In this light, the Slab-Column System can now be viewed independently from the conditions of its genesis, as a general rationalized structural system for variable applications.

The key to the flexible adaptability of the Slab-Column System is the unconventional use of the slab's central axis as the structural axis along which the supporting columns are located. Conventional frame systems use either beams for the support of slabs, or broad column capitals and arms, that hold slabs by their edges. When slabs are supported by their edges, two slabs at least must bear on one column for the structure to have continuity; and continuity requires structural joinery and regular geometric relationships of bays. In the case of the Slab-Column System, one slab and its supporting columns can be viewed as a stable and independent structure, free of the need to connect to adjacent slab-bays.

A second advantage of supporting slabs along their central longitudinal axis rather than their edges, is the possibility to alter the shape and size of slabs without needing special connections or elements. As long as the two central ribs of the slab are not interrupted, many variable shapes and sizes can be

derived, without disturbing structural stability.

The ribs of the slab can be interrupted only in the zone where the bending moment is small, or zero (dwg. 18). To divide the slab in two along its transversal direction is useful if cranes capable of lifting the basic slab cannot be employed. For housing loads, and with the cantilever of the slab functioning as a corridor, the division can happen at approximately 3.20 meters from the cantilevered edge, leaving 5.80 meters for the remaining part of the slab, which bears on the protruding ribs of the smaller part.

The casting molds for slabs are of the size of the basic slab SL-1. Slabs larger than SL-1 cannot be produced without fabricating new molds. However, a great number of slabs of variable shapes can be produced using the SL-1 molds, if a method of subtraction from the basic, by blocking out parts of the mold, is introduced (dwgs. 19-22). Usually, in industrialization, any diversion from the repeated element results in high costs. In the case of the Slab-Column System, the price of flexibility is negligible, since all the method involves is the introduction of an insert, a stopper, that can be as simple as a strip of wood.

With the method of subtraction from the basic mold, slabs of many different shapes can be produced, which become useful tools in the hands of architects whose vision goes beyond the box.

Circular and curving buildings, for example, can be realized by the simple repetition of slab SL-9 whose sides are diagonal, without having to redesign the basic system dwgs. (23 & 24). In general, the diagonal edge facilitates gradual changes of direction, without disturbing the continuity of structure.

The same principle of subtraction from the basic, can also be applied to stairs. The basic stair element consists of one run of steps continuous with the two top and bottom half landings. By blocking out the landings from the basic mold, a run of steps can be produced which facilitates the buildings adaptation to slopes, along the direction of the building's corridors (dwgs. 25 & 26). The stair element becomes a continuation of the servicing corridor; it is placed between slabs of different levels, suspended from the outer rib of the top slab by an embedded steel angle, while leaning on the outer rib of the lower slab.

The system can also be adapted to slopes along the direction of the slab's axis (dwg. 27). On the high side of the slope, the

slab can be placed on a modified foundation whose top surface is identical to the top of columns. On the lower side of the slope, if the slope is steep, a two-story column can be employed (dwgs. 28 & 29). The two-story column is similar in its shape, details and connections to the basic column. For milder slopes, the slab can be supported normally on the basic column (drawn with dashed lines, dwg. 27).

The two-story column is not solely useful for the system's adaptation to slopes. Primarily, it was developed for structures with slabs on only the second and fourth levels, which could be the bases for duplexes that could rise to a total of six stories (dwgs. 30 & 31). The double height within structures, gives a third dimension to the concept of flexible adaptation of dwellings to empty building platforms. In the past, two-story buildings were built soundly, without the specialized input of architects and engineers. Through the years, every culture has developed indigenous methods of construction, which have been improved for centuries through repeated application. However, traditional methods are not a requirement. Marketed small component light-weight systems can also be employed for the

construction of two-story dwellings within the limits of the supporting structure. The structure provides ground floor at many levels. It is limited to offer what traditional methods and light-weight systems cannot achieve. The method of its occupation by dwellings can take any form, from systemic rationalized methods to haphazard squatting.

The simplicity of the Slab-Column System is paradoxically contrasted with the diversity and plentitude of its applications. The high level of flexibility gives to the system a certain plasticity which is atypical of rationalized structural systems. The system's adaptability to irregular street patterns (dwgs. 32 & 33), for example, makes possible the use of the Slab-Column System in old city centers and villages, where the employment of the leading rationalized systems of the past was inconceivable without massive destruction of local urban patterns and architectural typologies.

The examples of the system's adaptability to diverse sites described and demonstrated so far, depict only certain basic conditions. The actual possibilities are numerous, but little new information would be revealed by undertaking their detailed

explanation. It is hoped that the examples already provided offer adequate information for the understanding of the potentials and internal functioning of the presented system.

CONCLUSION

The industrialization of building components for the prefabrication of buildings was born out of the need for the economical and rapid provision of healthy and safe living environments. Ever since its development, prefabrication of buildings is justifiably practiced when economy and speed are the prevailing constraints.

Concrete panel systems, which were gradually established as the primary building prefabrication method, demonstrated in time a poor performance in terms of reception of change, adaptability to diverse contexts and economical use of the relatively expensive cement and steel. These limitations of panel systems would have been of no relevance, if buildings were not to undergo transformations in time, if building systems were to be only applied to their originally intended sites and if cost minimization were of secondary importance. History, however, proved that this is not the case.

Open systems offer an alternative direction to

industrialized construction. The differentiation of permanent from non-permanent elements and the organization of only the permanent ones in the form of a rationalized structural system, relieve all walls from structural role, allowing for flexible and transformable internal divisions with walls of any material.

The acceptance of open systems involves, above all, a change of attitude in relation to the role of industrialization in construction. A building system alone, must not be expected to formulate complete buildings. When this happens, the resulting buildings are characterized by rigidity of layouts and unadaptability to the specific conditions of the site and general context. Architecture cannot be generated by the mere assembly of components. Architecture can only be designed; and a correct design process addresses the specifics of each individual site, thus rendering individual buildings with a degree of uniqueness. The prefabrication and erection of only the structure of buildings, as open systems suggest, allows for the particular designed appropriation of each separate structure to architecture.

Within this conceptual framework, the Slab-Column System was

developed. It is an open system which goes one step beyond conventional frames. In addition to offering the possibility for flexible and changeable divisions of its structural platforms, the system is adaptable to a diversity of sites.

The Slab-Column System broadens the applicability of large-scale industrialized construction methods while it remains consistent with economization, the nucleus of the development, and the fundamental requirement of any form of industrialization. The diverse applications of the Slab-Column System emerge as a natural consequence of a respect for people, architecture, and the laws of statics.

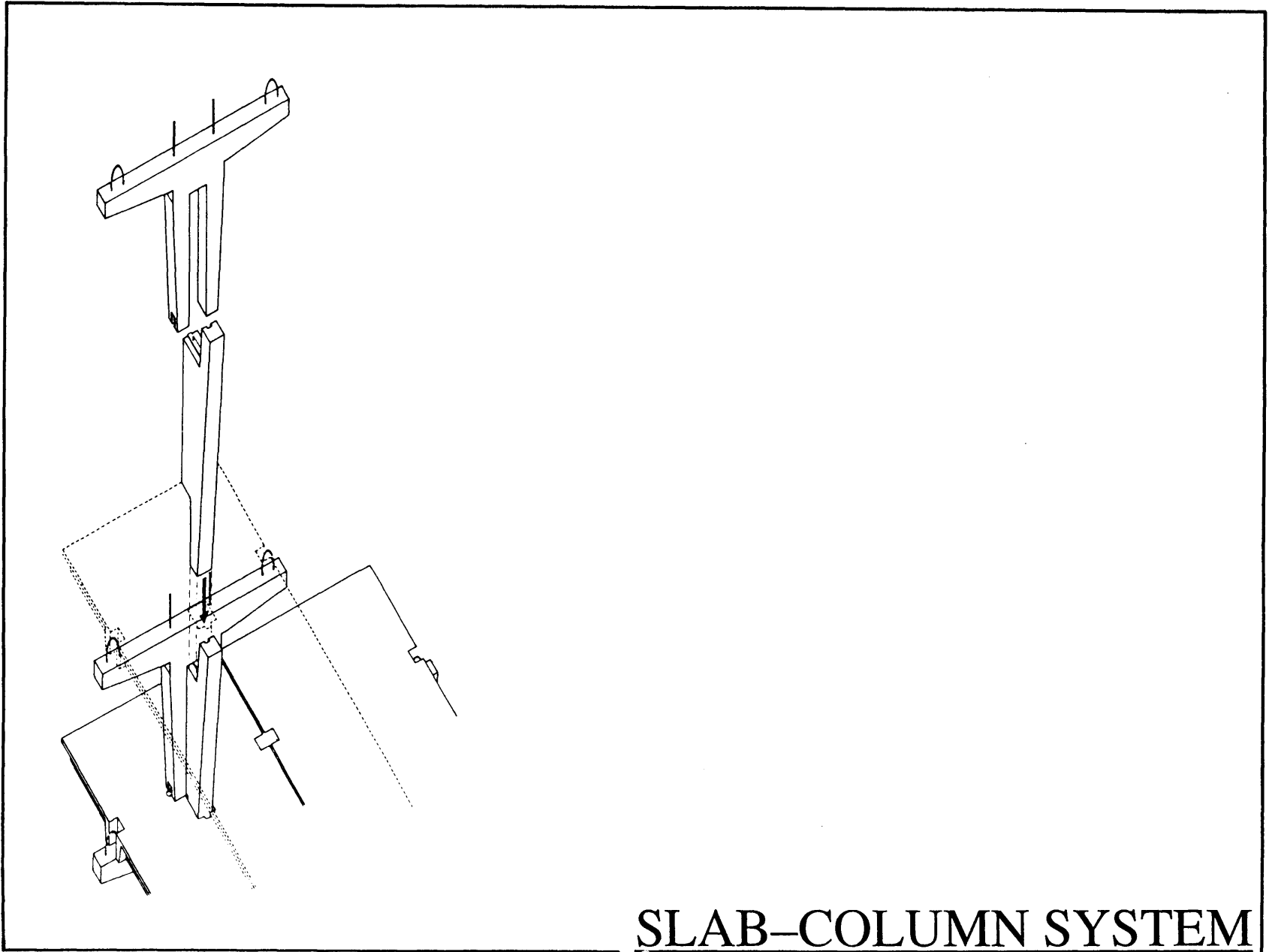

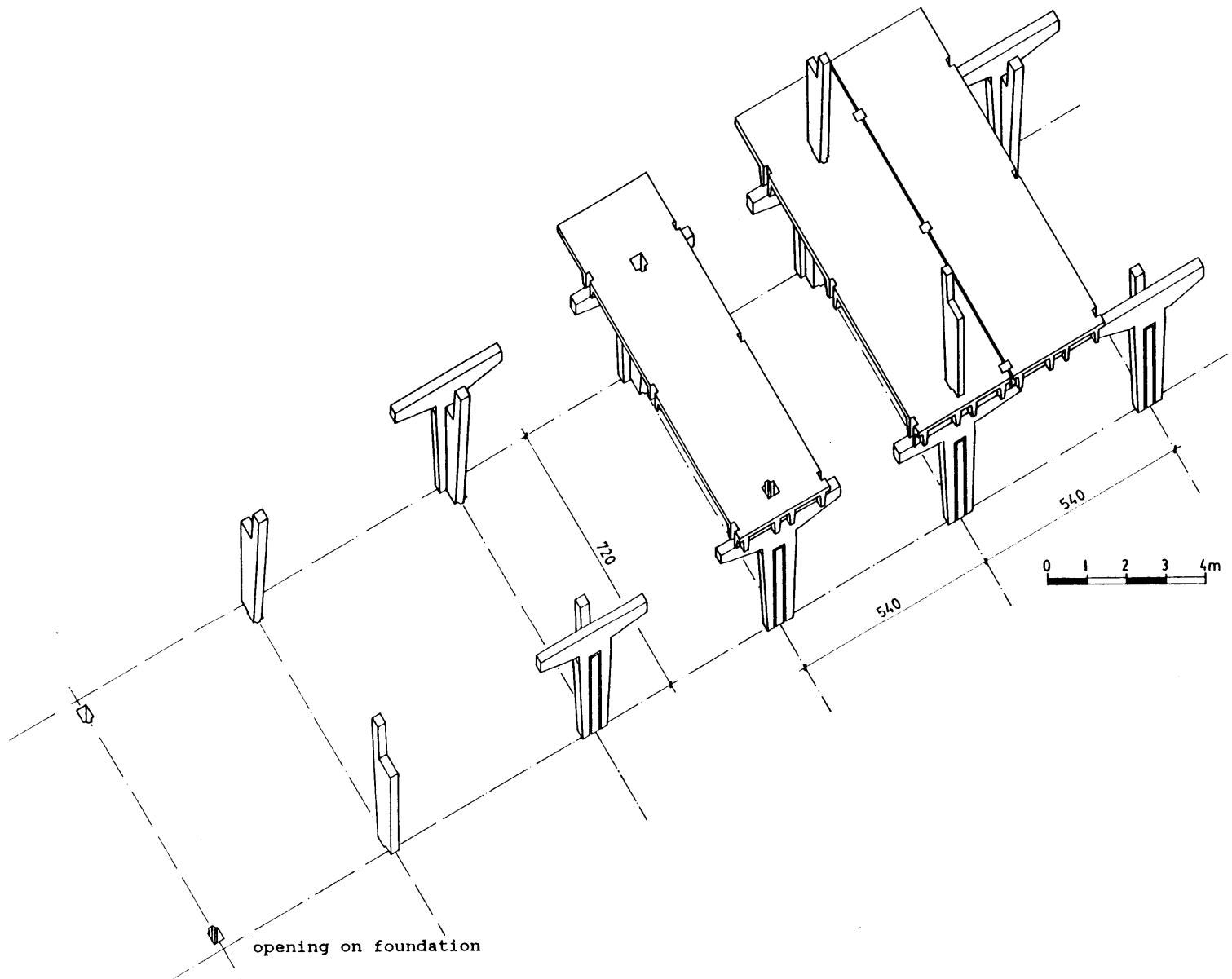

DWG. #1: PARTIAL ASSEMBLY OF ELEMENTS

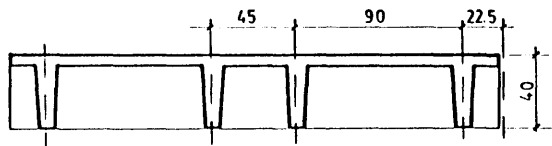
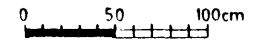
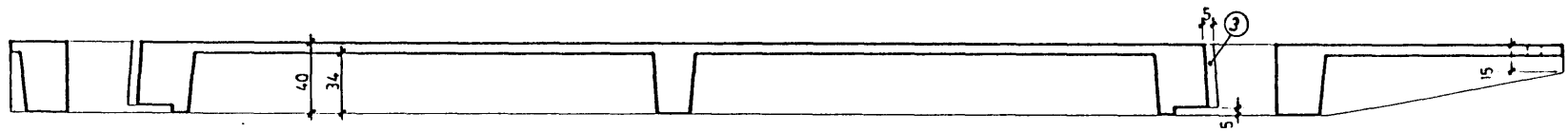
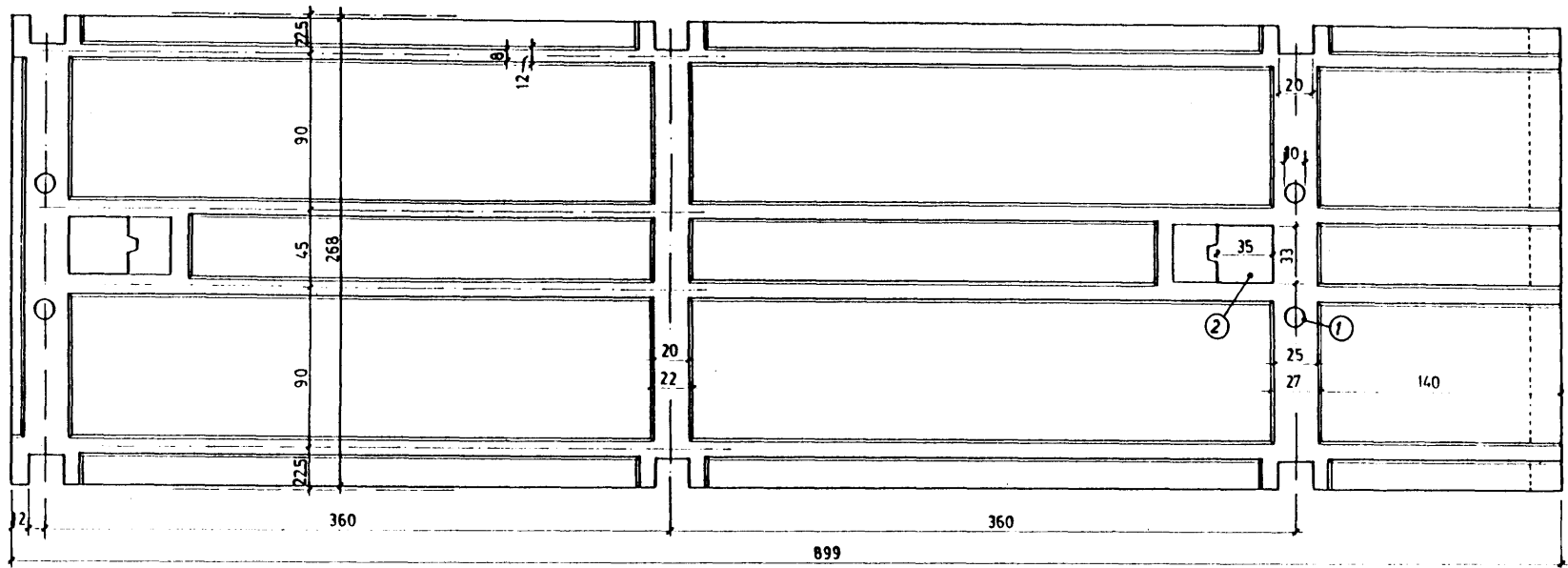

1. opening for penetration of re-bar from C-2
2. opening for penetration of C-1
3. groove for placement of concrete in joint

DWG. #2: SLAB SL-1 / VIEW OF UNDERSIDE & SECTION

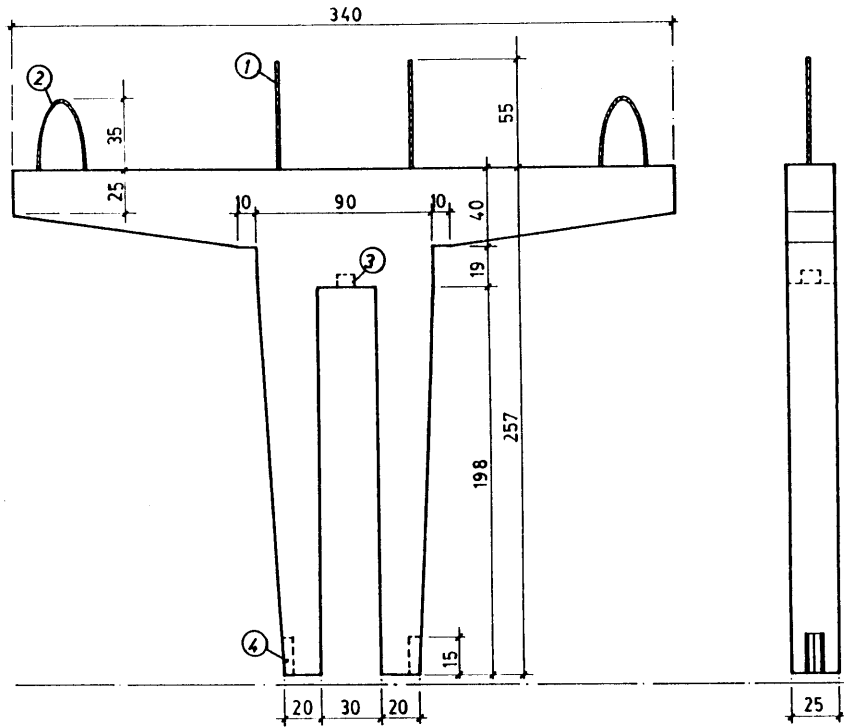

COLUMN PART C-2

1. re-bar for connection with C-2 above
2. steel loop for connection with slabs
3. embedded pipe for correct positioning on C-1
4. embedded steel angle for connection with C-2 below
5. pin receiving pipe from C-2
6. embedded pipe for correct positioning on C-1
7. pin receiving pipe from C-1

Note: The elements are represented in pure form. For practical and economic purposes, inclined sides of C-2 can be made vertical

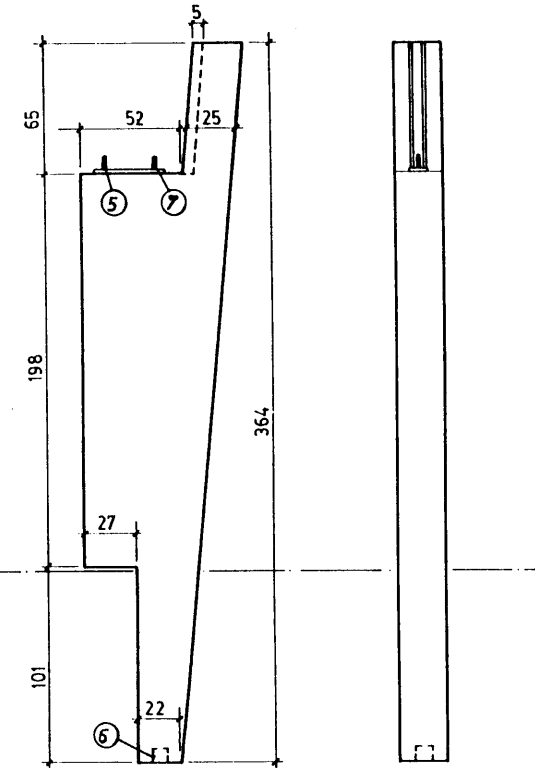

COLUMN PART C-1

0 50 100cm

DWG. #3: COLUMN PARTS C-1 & C-2

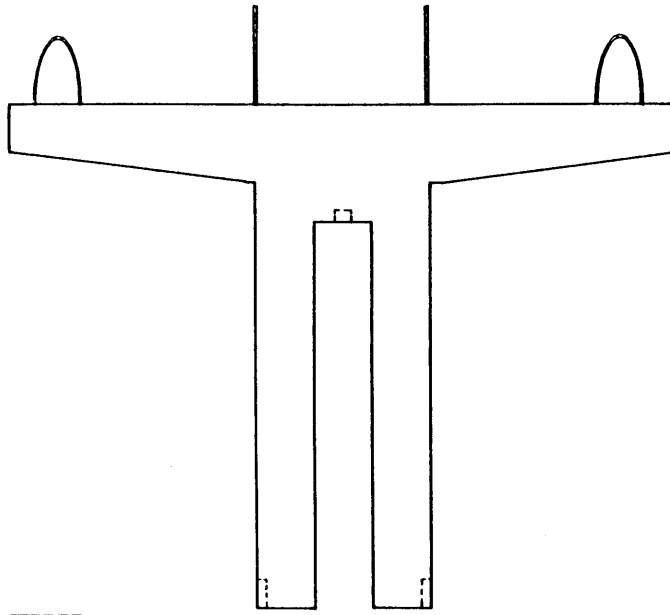

C-2a
supports adjacent slabs

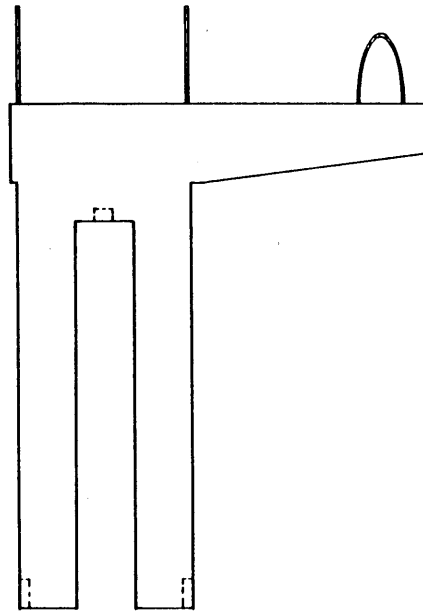

C-2b
supports one adjacent slab

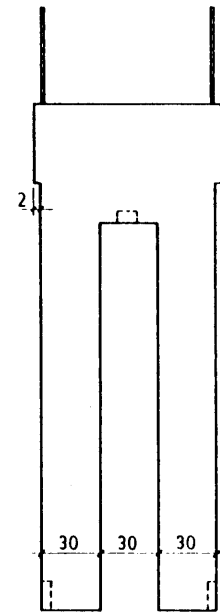

C-3c
supportrs no adjacent slabs

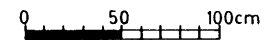

Note: For all C-2 variations
C-1 remains the same

DWG. #4: COLUMN REVISED / VARIATIONS OF C-2

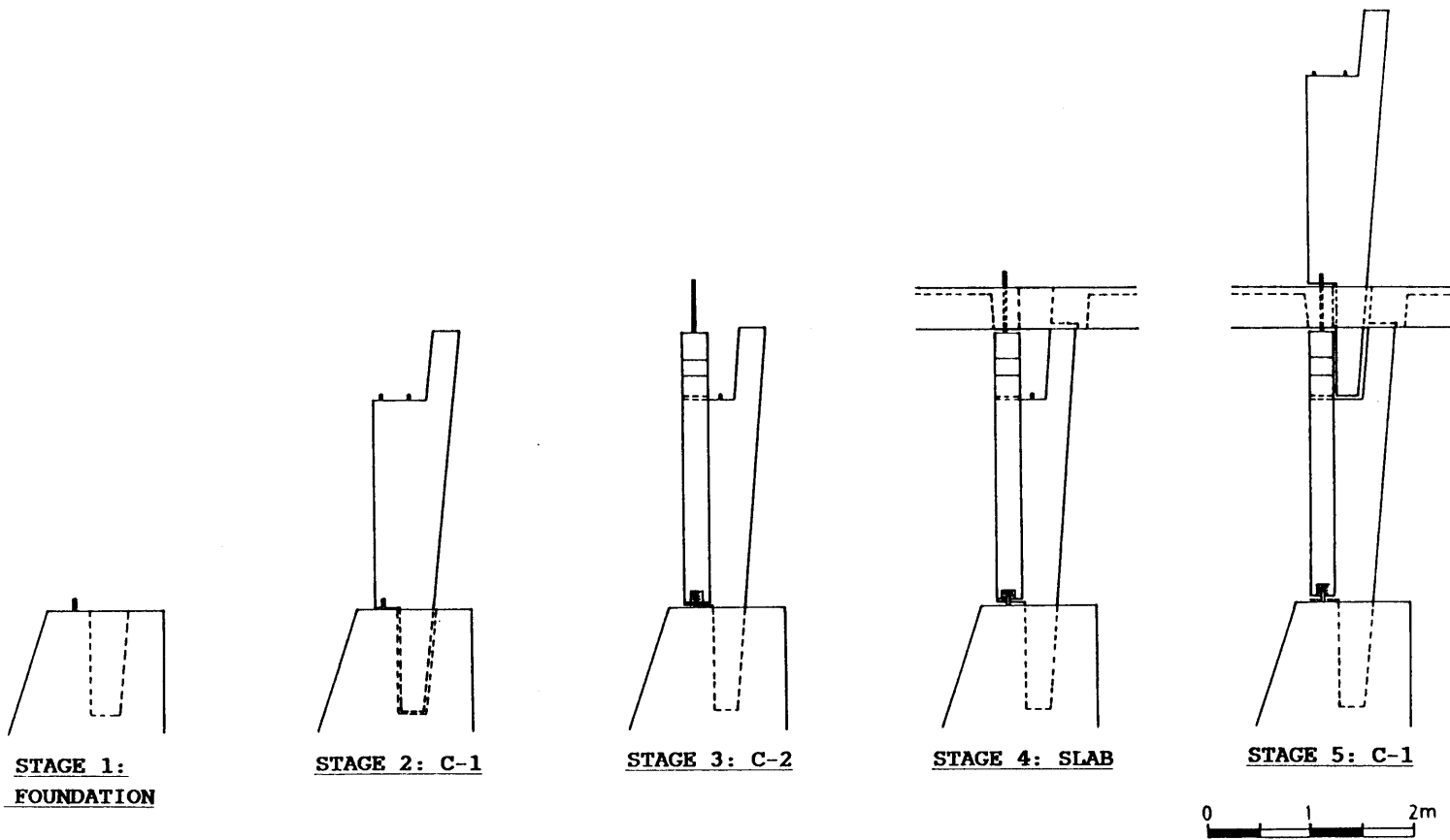

DWG. #5: ASSEMBLY SEQUENCE OF ELEMENTS

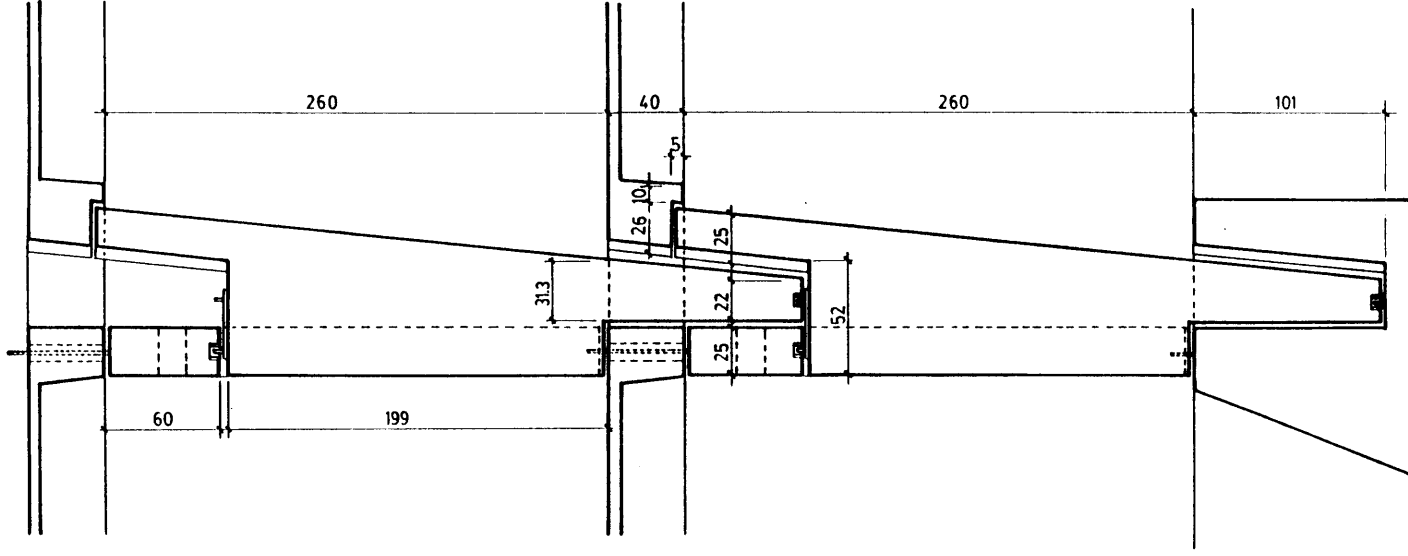

DWG. #6: COLUMN-SLAB CONNECTION / SECTION THROUGH C-I

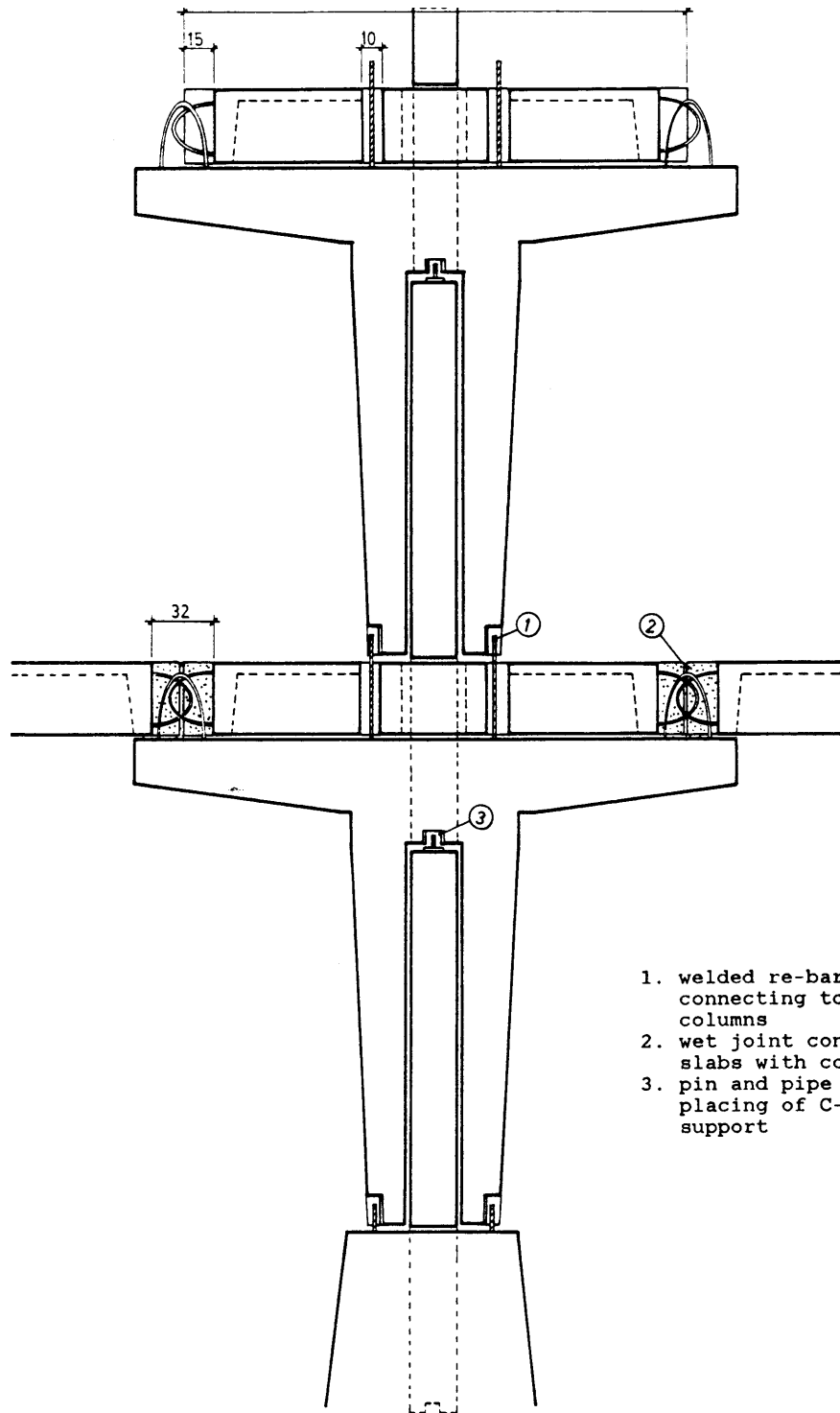

1. welded re-bar on steel angle connecting top to bottom columns
2. wet joint connecting adjacent slabs with column arm
3. pin and pipe for correct placing of C-2 and for initial support

0 50 100cm

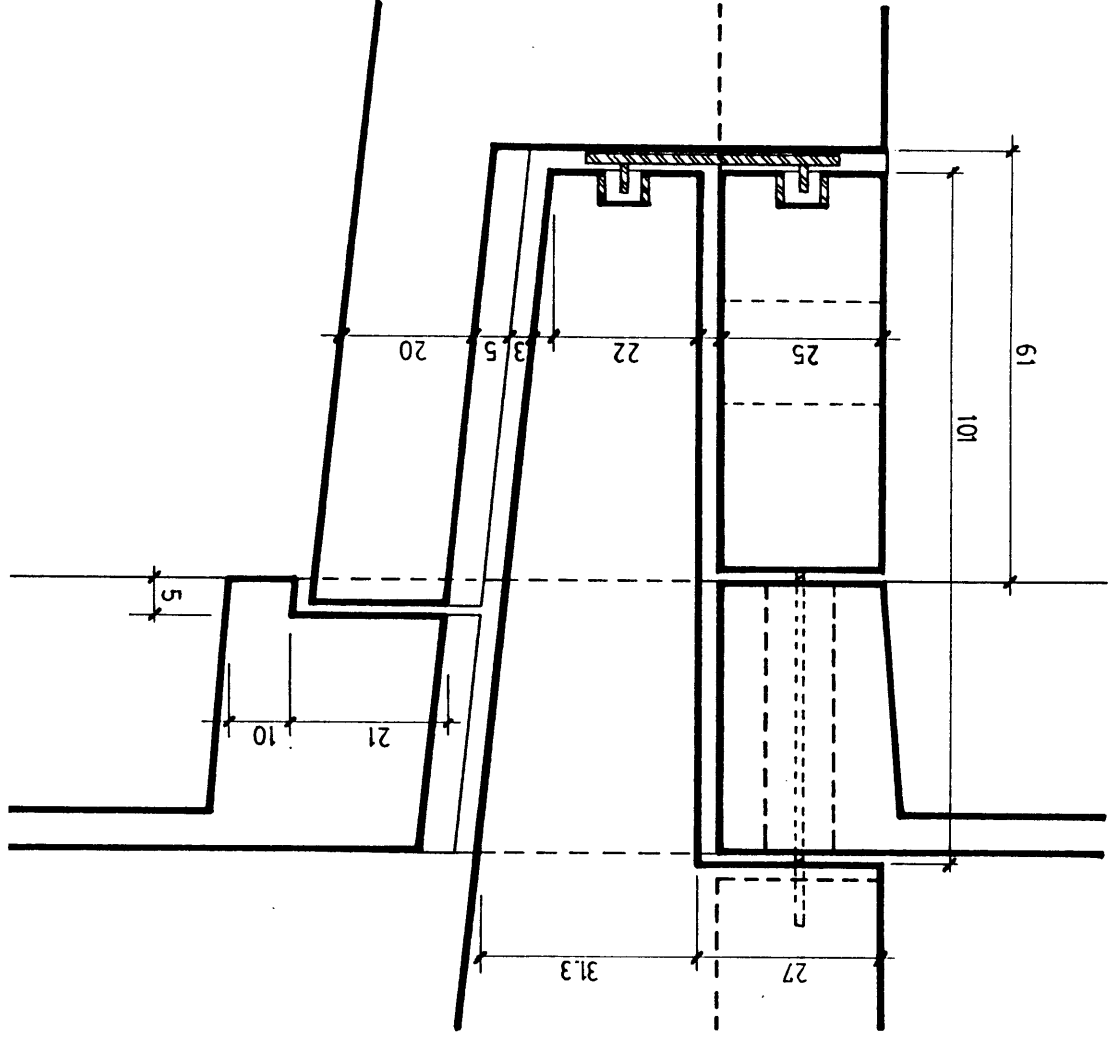
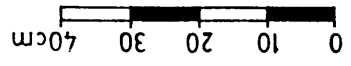

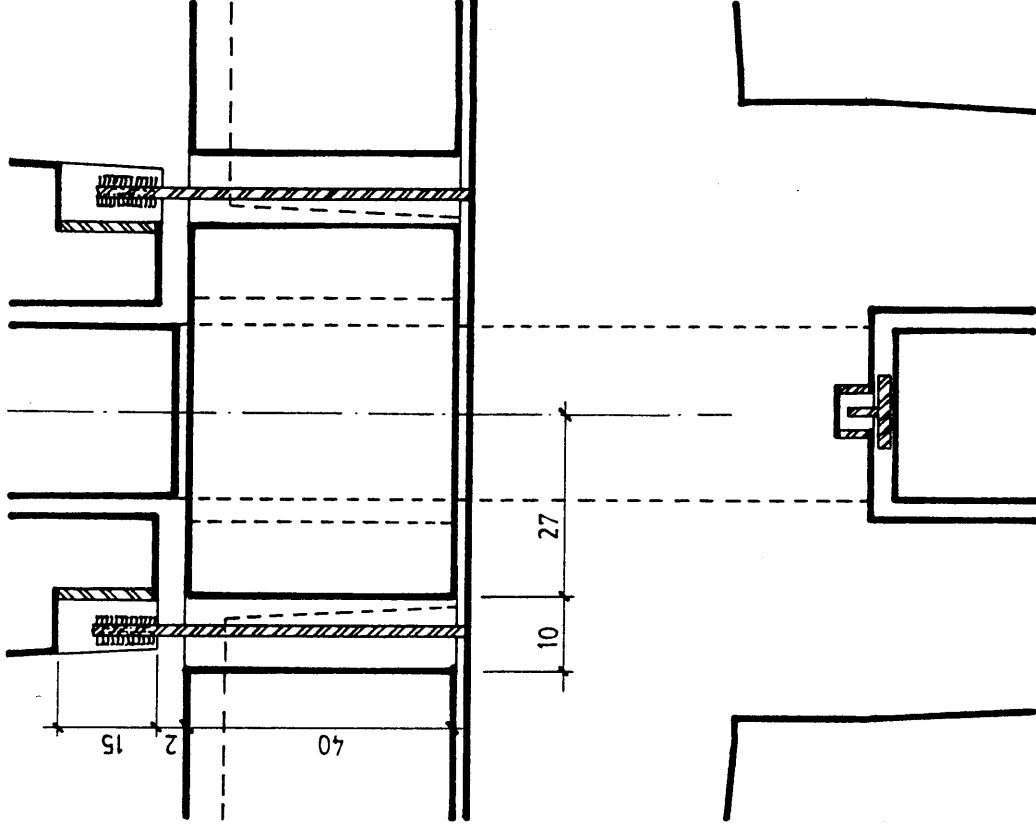

DWG.#9: CONNECTION OF COLUMNS & SLAB / DETAIL #2

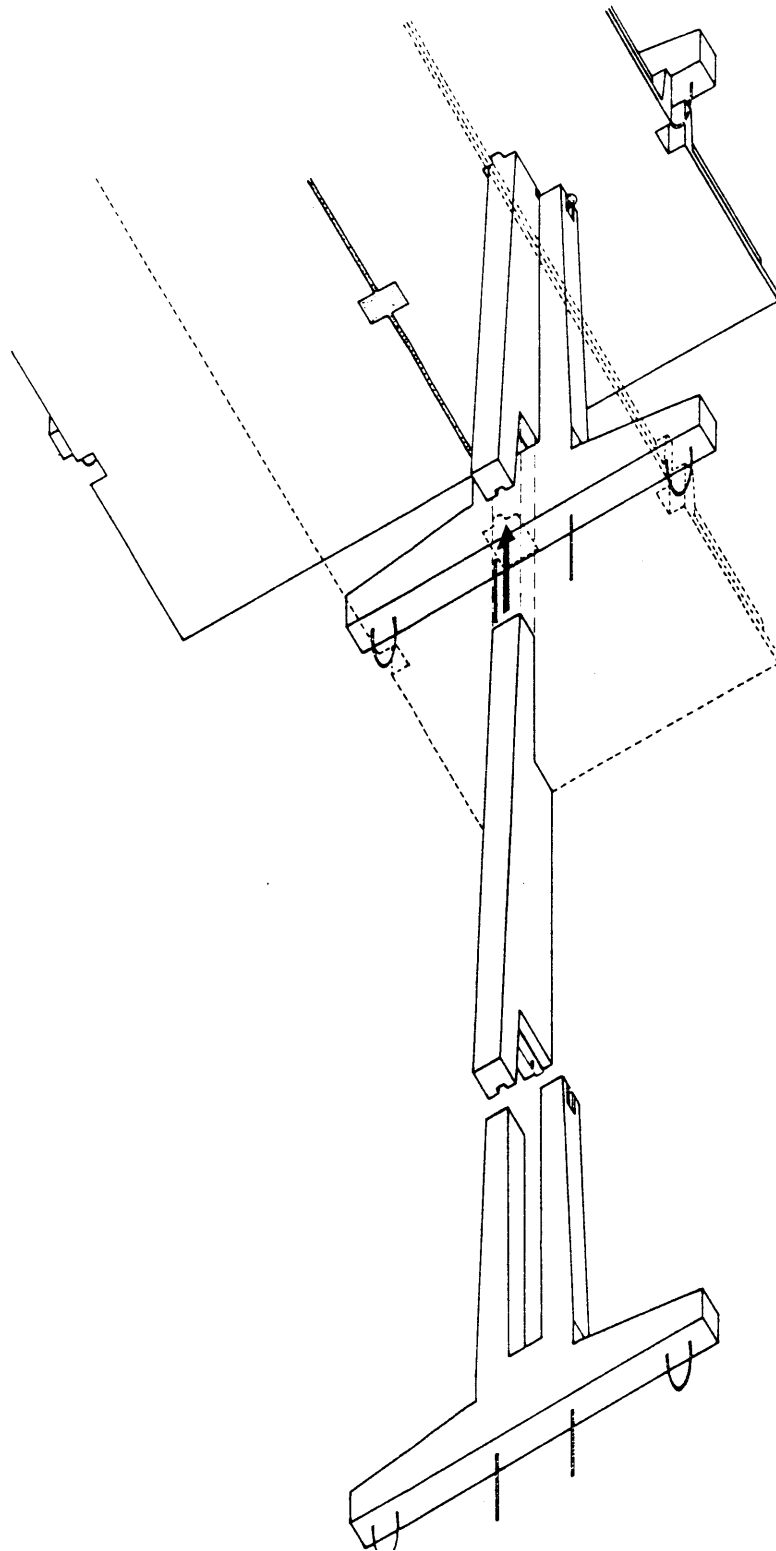

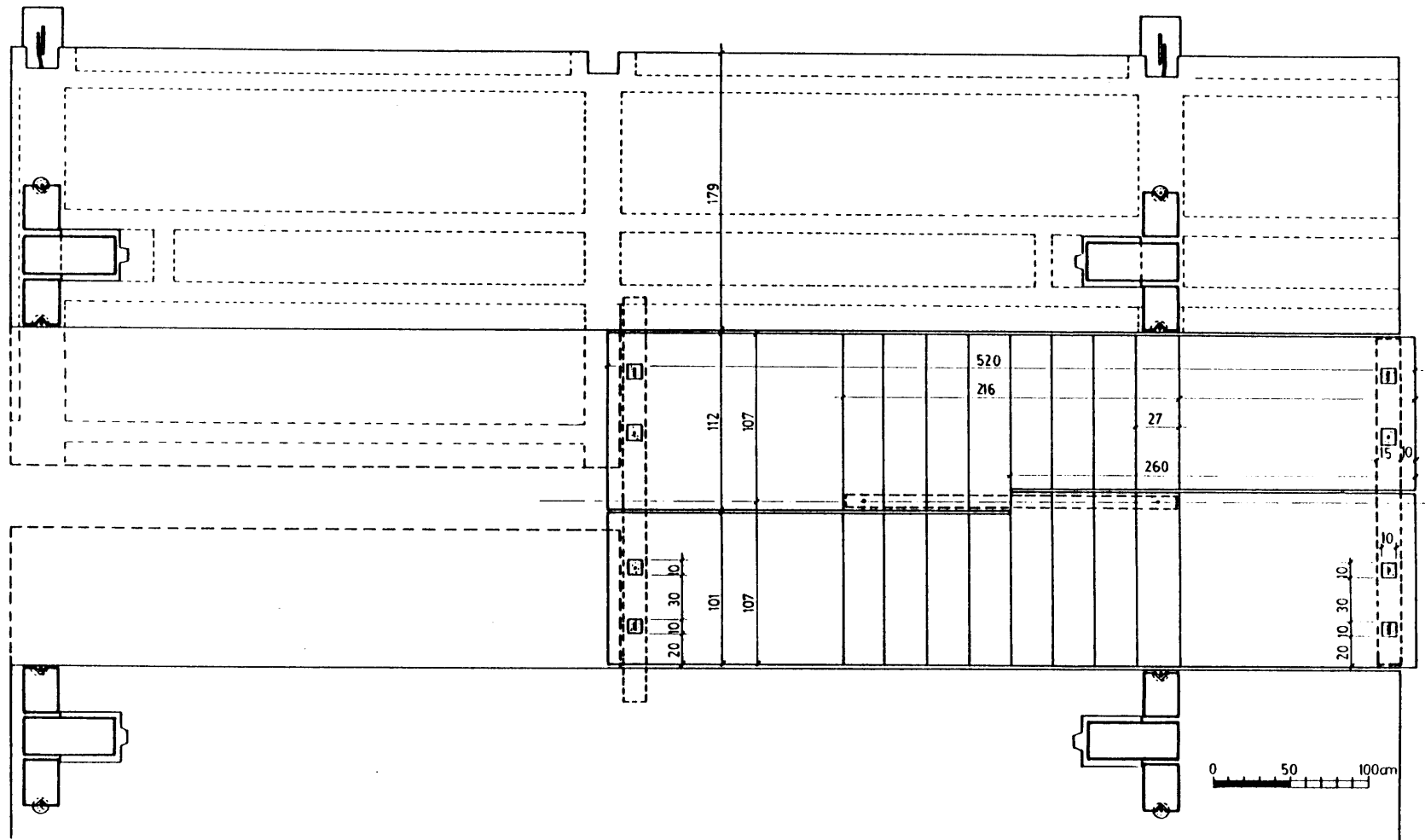

DWG.#11: STAIRS & ADJACENT SLABS / PLAN

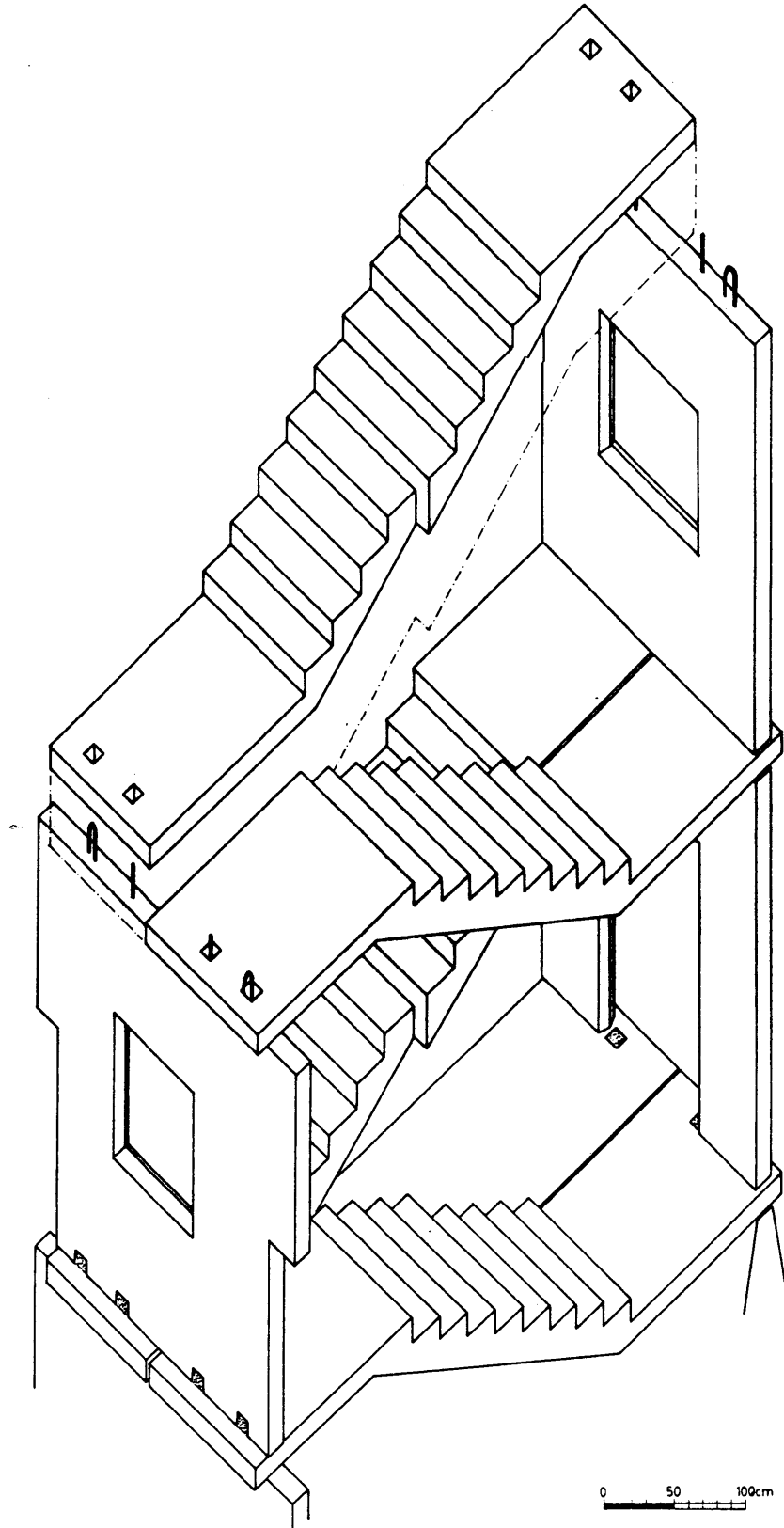

1. hole for connection with side of stair
2. same slope as stair
3. pipe and pin placement control
4. level of finished floor

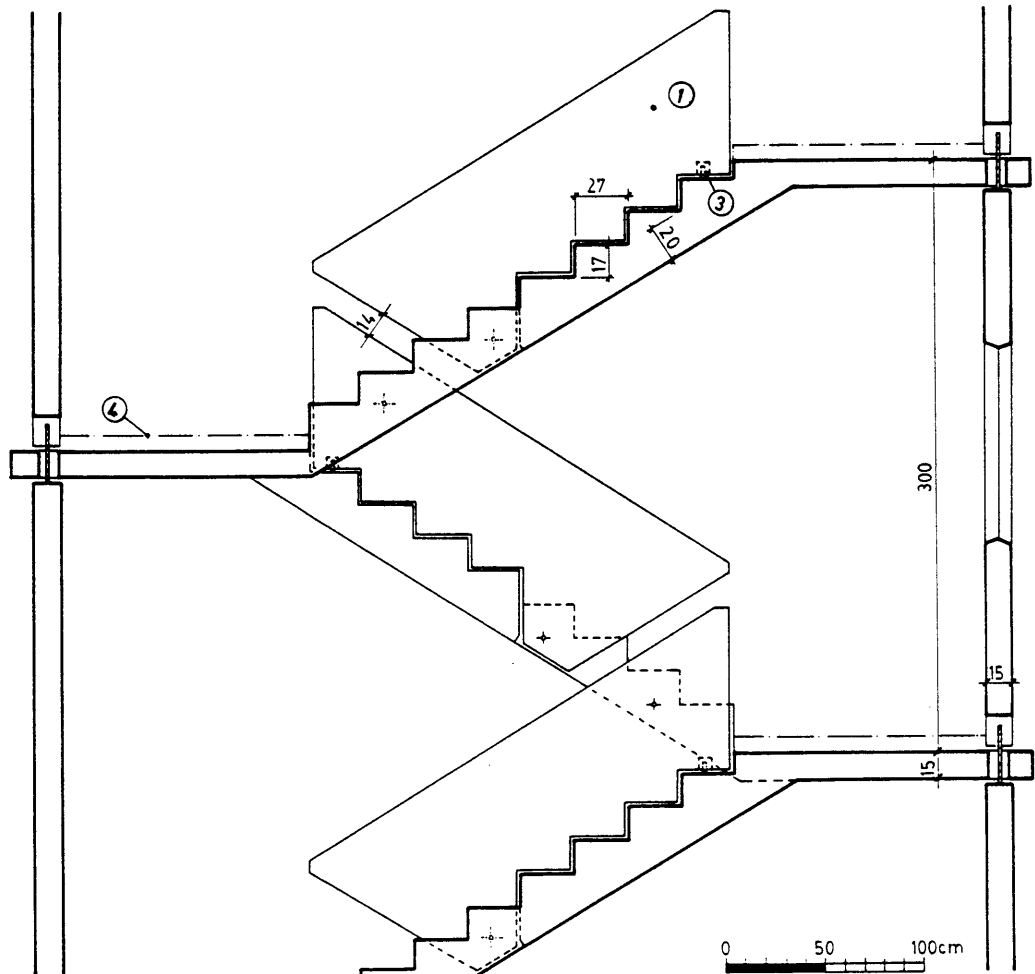
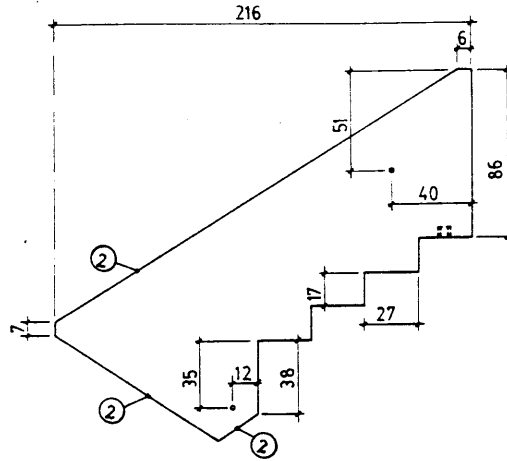

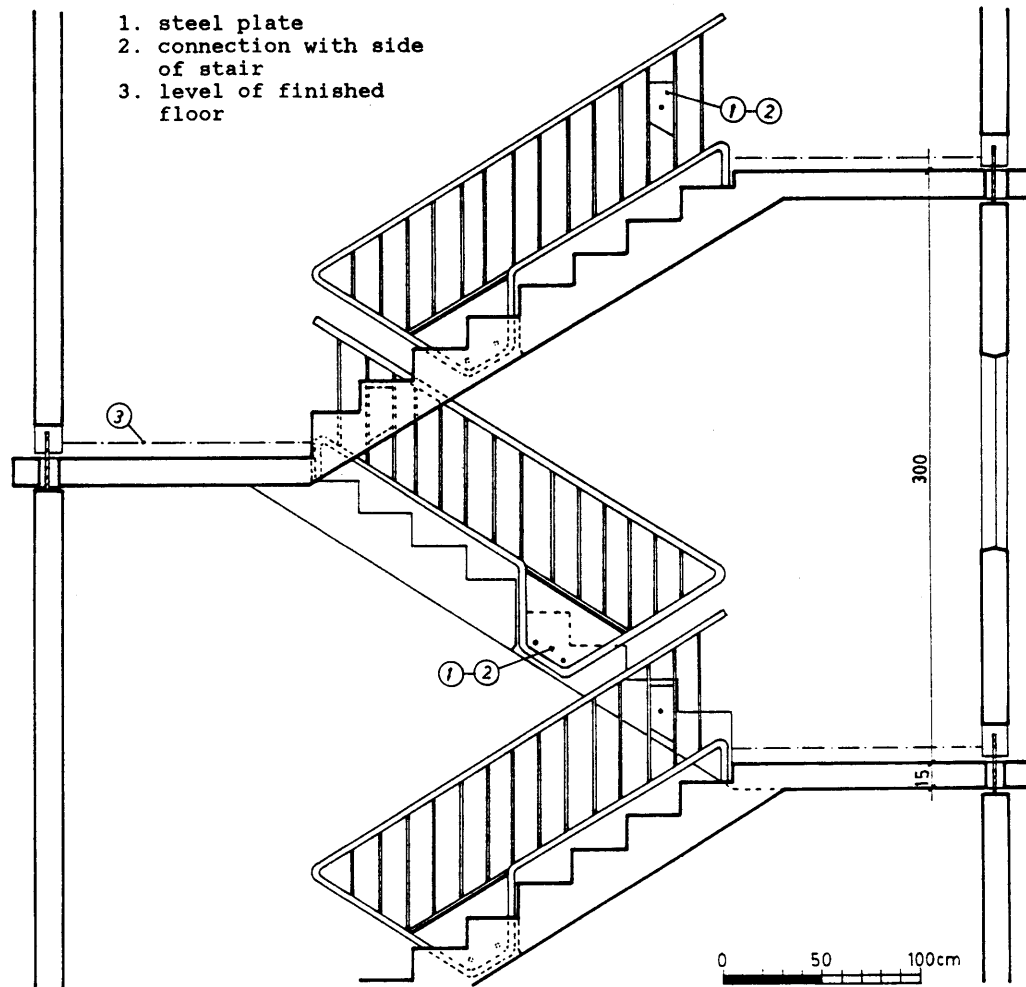

DWG. #14: STAIR SECTION / RAILING ALT. # 2 / STEEL

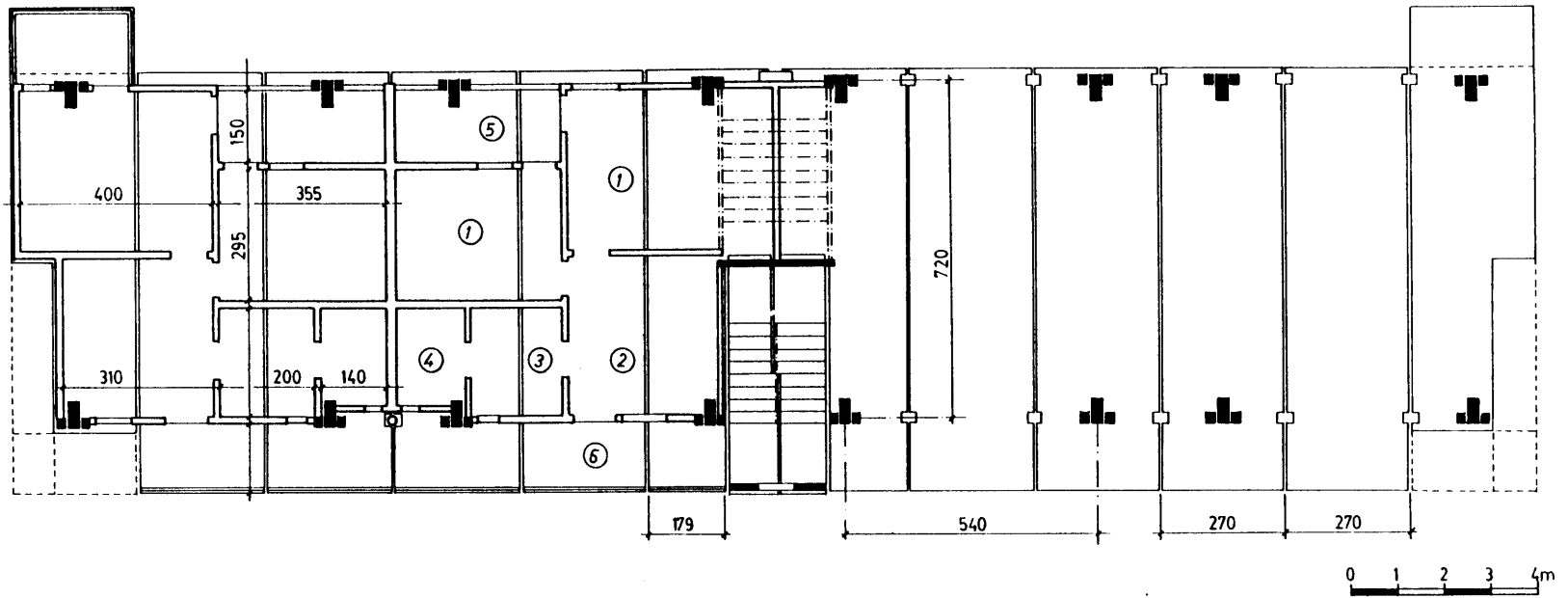

- 1. bedroom
- 2. living room
- 3. kitchen
- 4. bathroom
- 5. loggia
- 6. exterior corridor

DWG. #15: BUILDING PLAN / ALT. #1

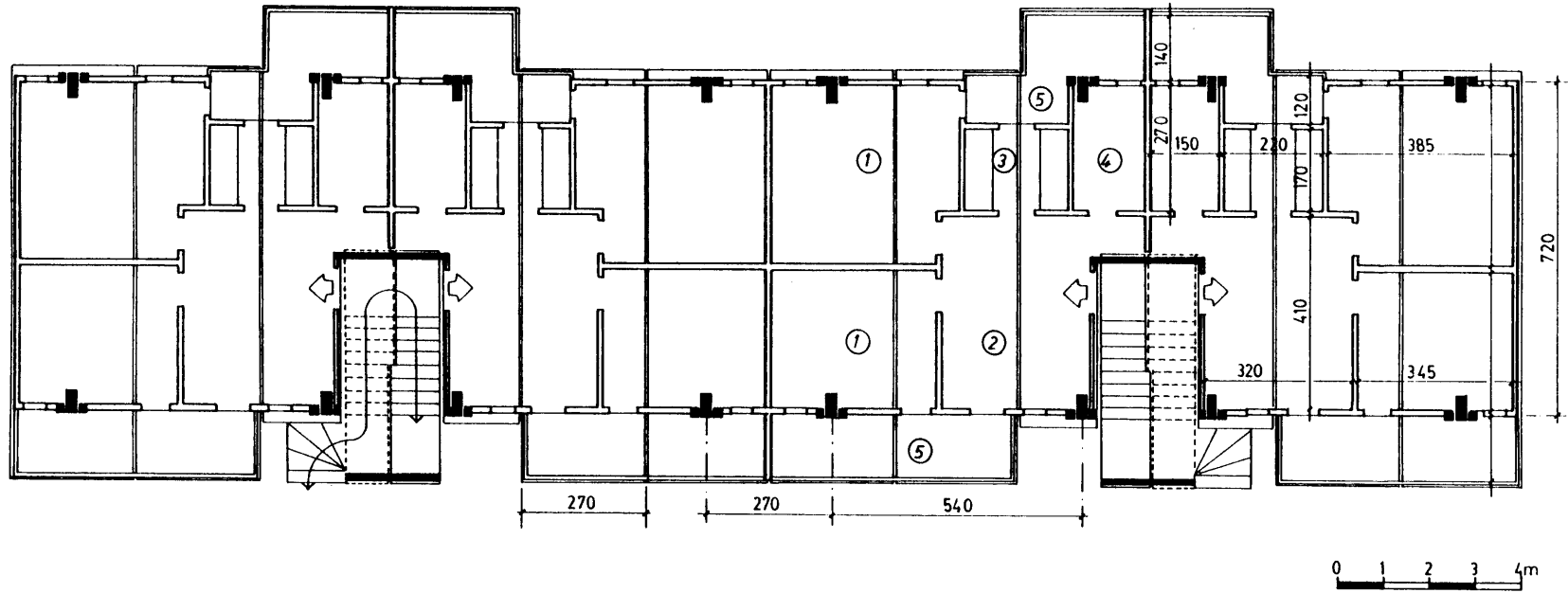

- 1. bedroom
- 2. living room
- 3. kitchen
- 4. bathroom
- 5. balcony

DWG. #16: BUILDING PLAN / ALT. #2

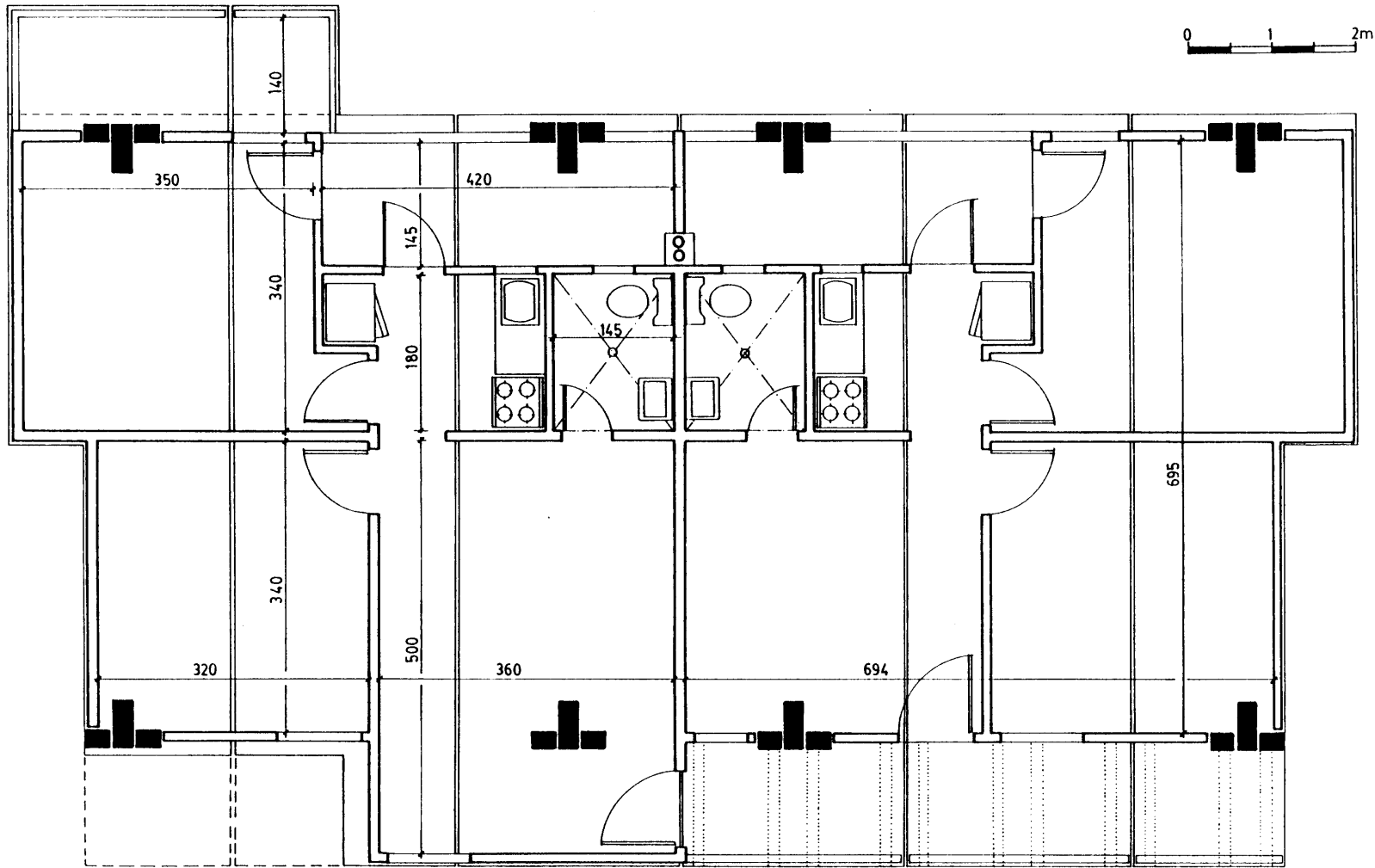

----- alternative position of slabs

DWG. #17: TYPICAL APARTMENT PLAN / ALT. #3

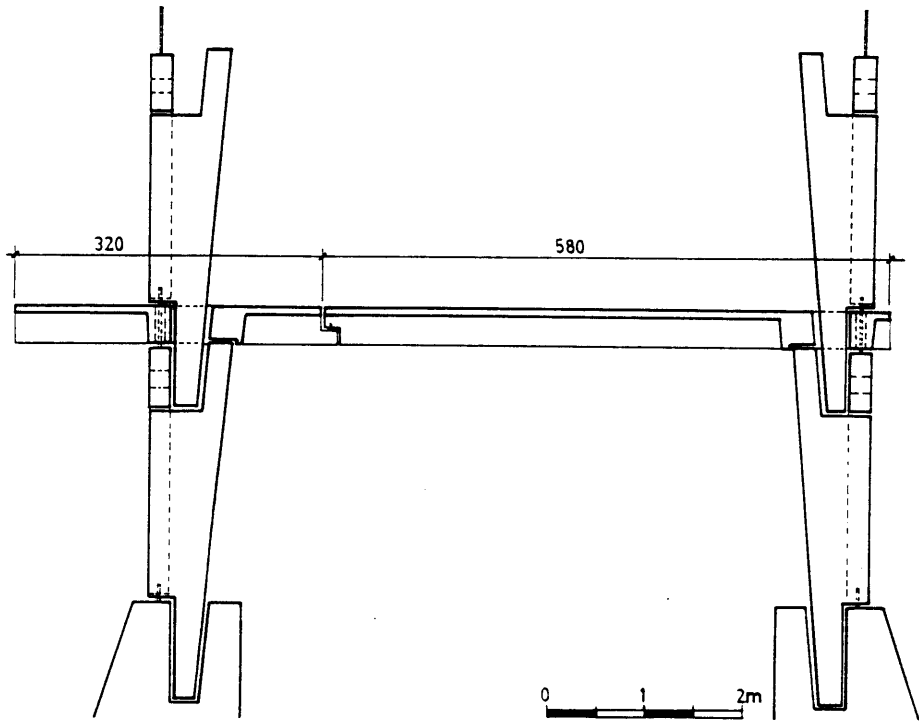
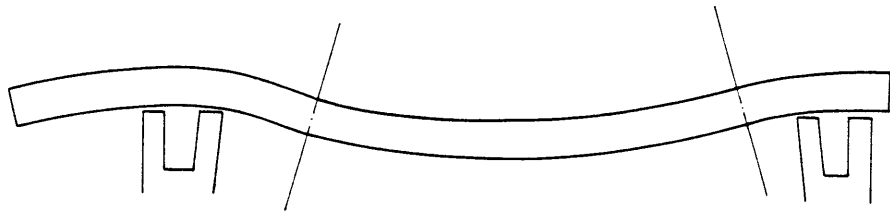
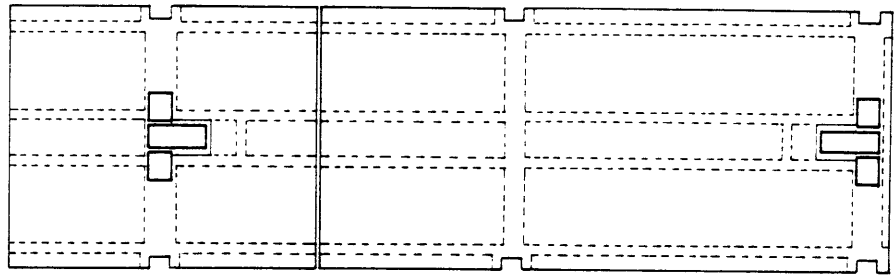

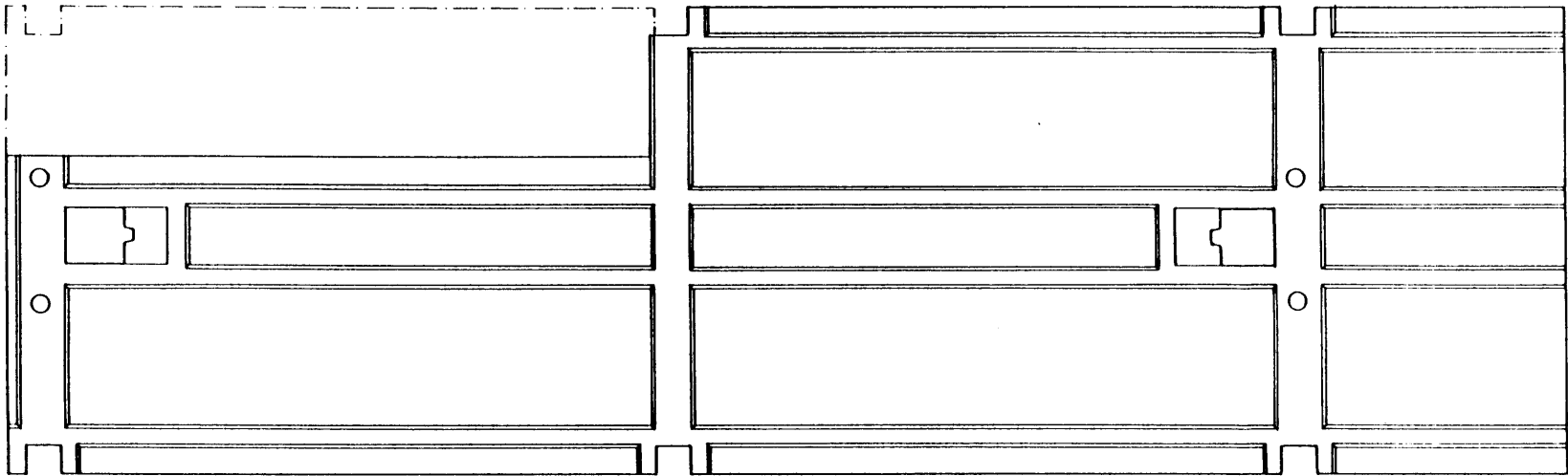

SL-2

SL-3

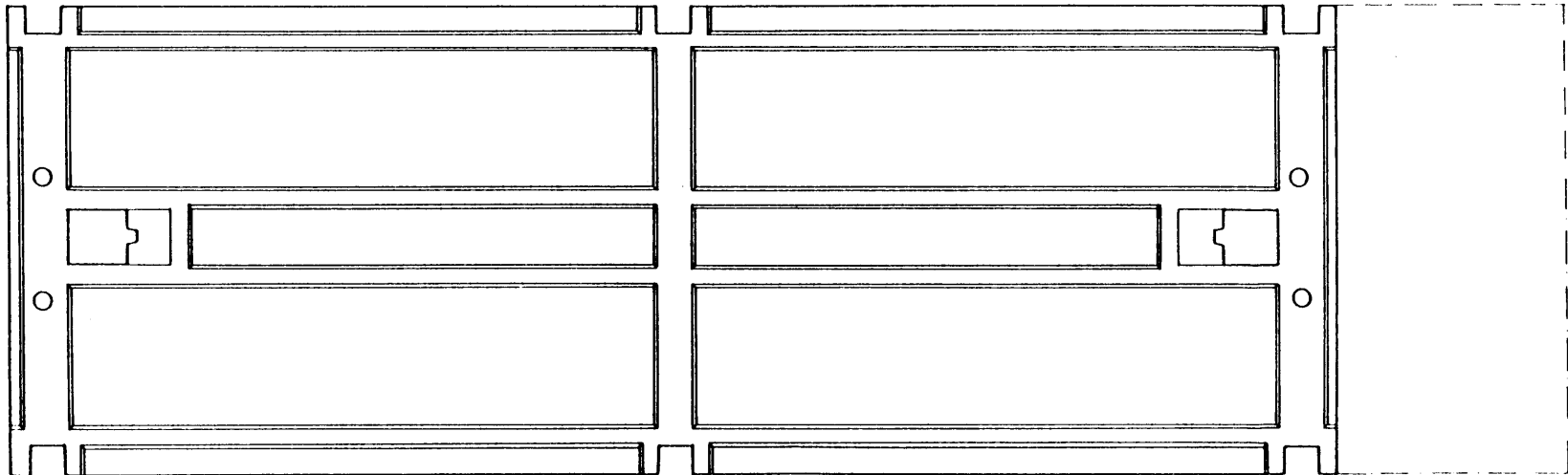
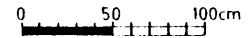

DWG. #19: SLAB VARIATIONS / SL-2 & SL-3

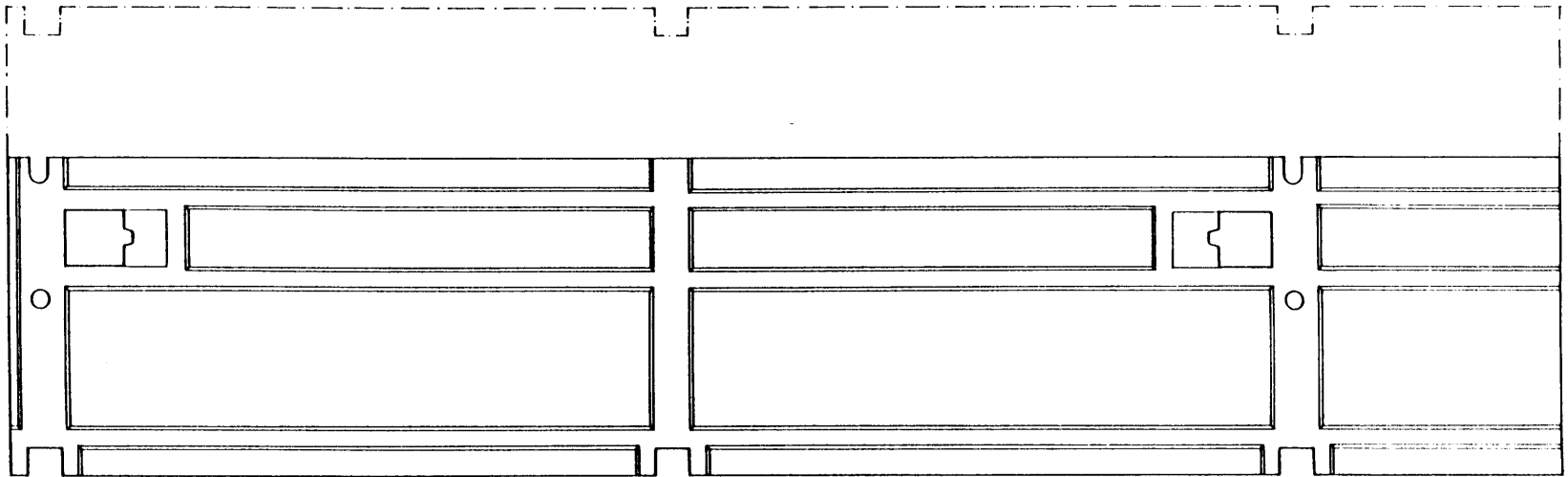

SL-4

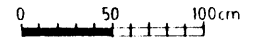

SL-5

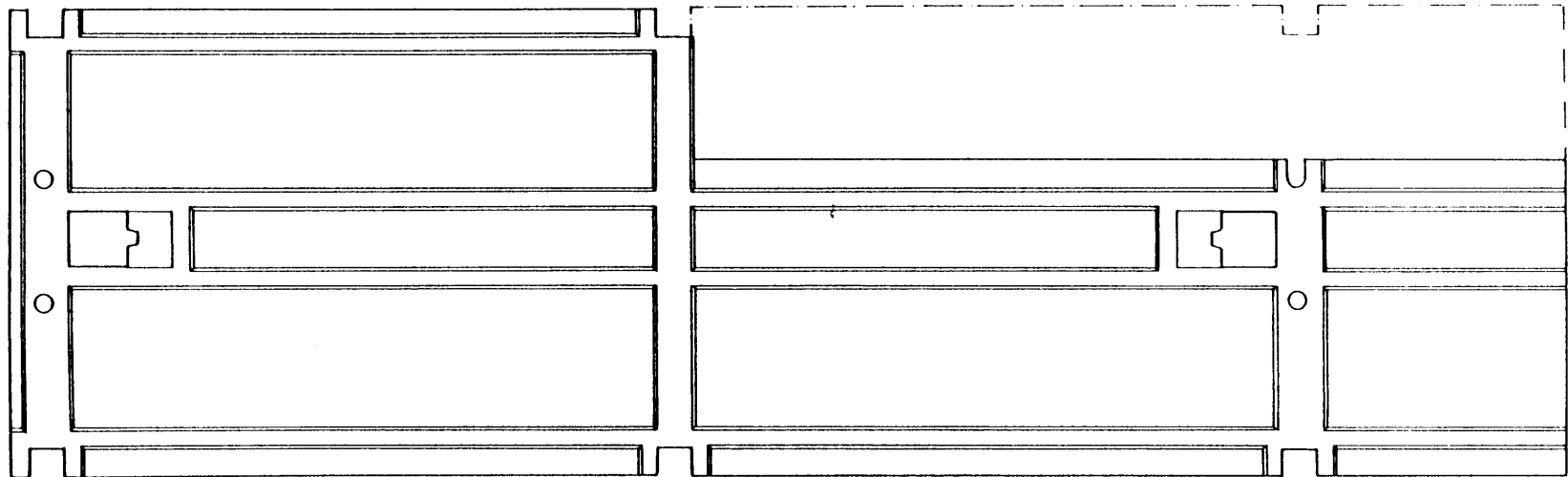

DWG. #20: SLAB VARIATIONS / SL-4 & SL-5

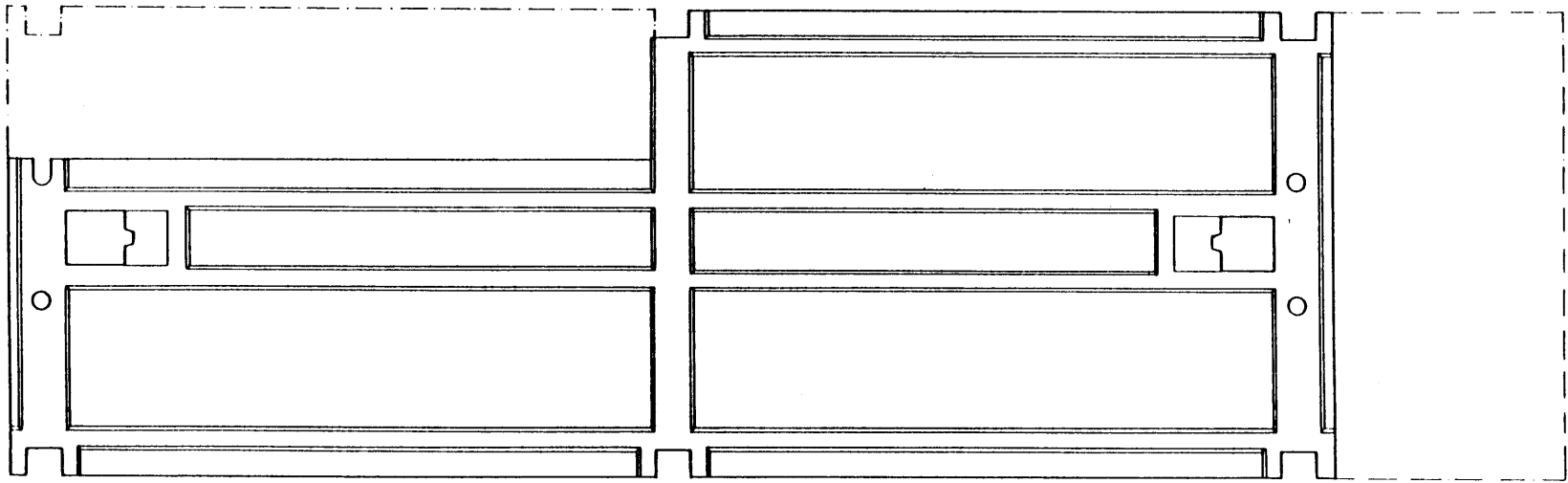

SL-6

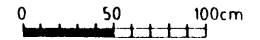

SL-7

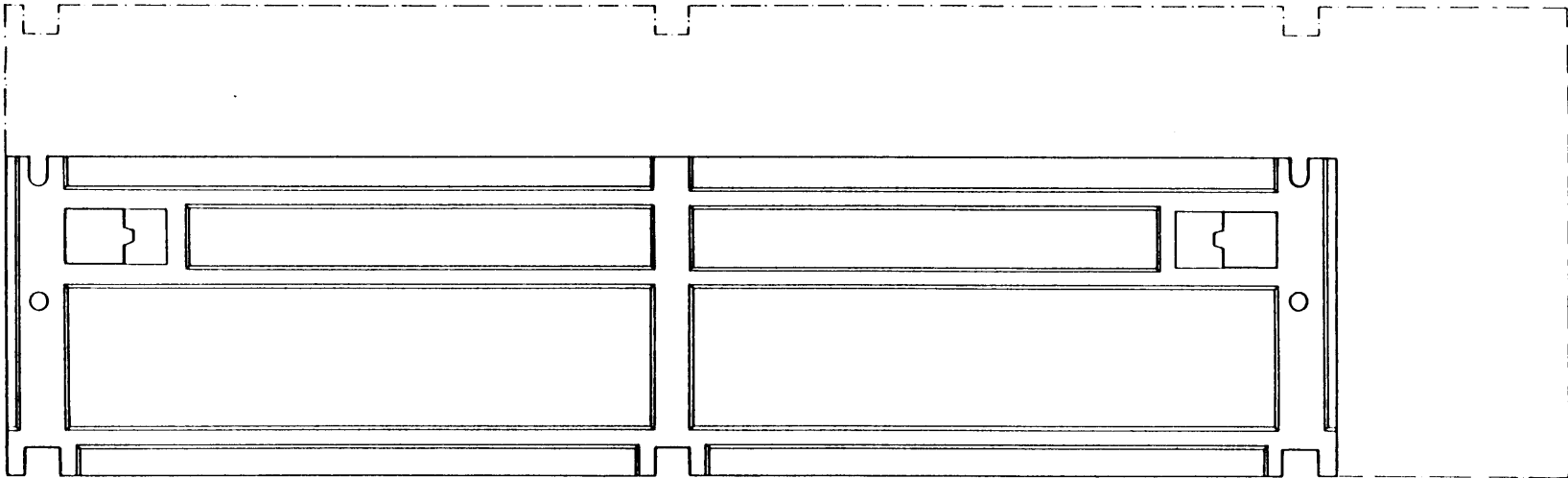

DWG. #21: SLAB VARIATIONS / SL-6 & SL-7

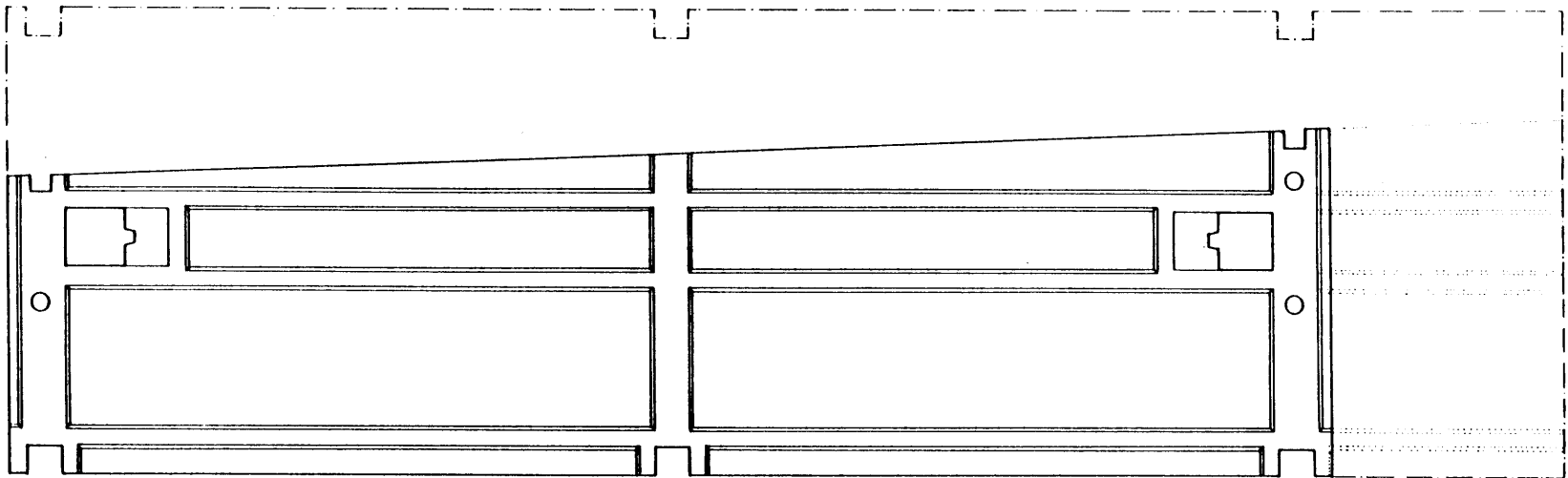

SL-8

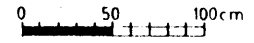

SL-9

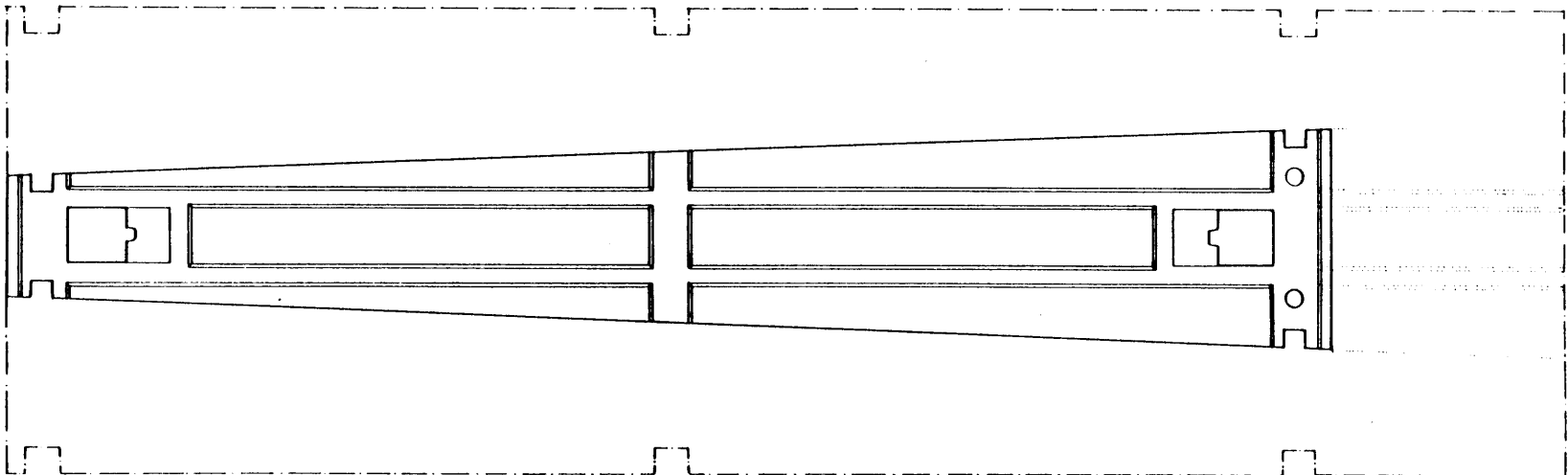

DWG. #22: SLAB VARIATIONS / SL-8 & SL-9

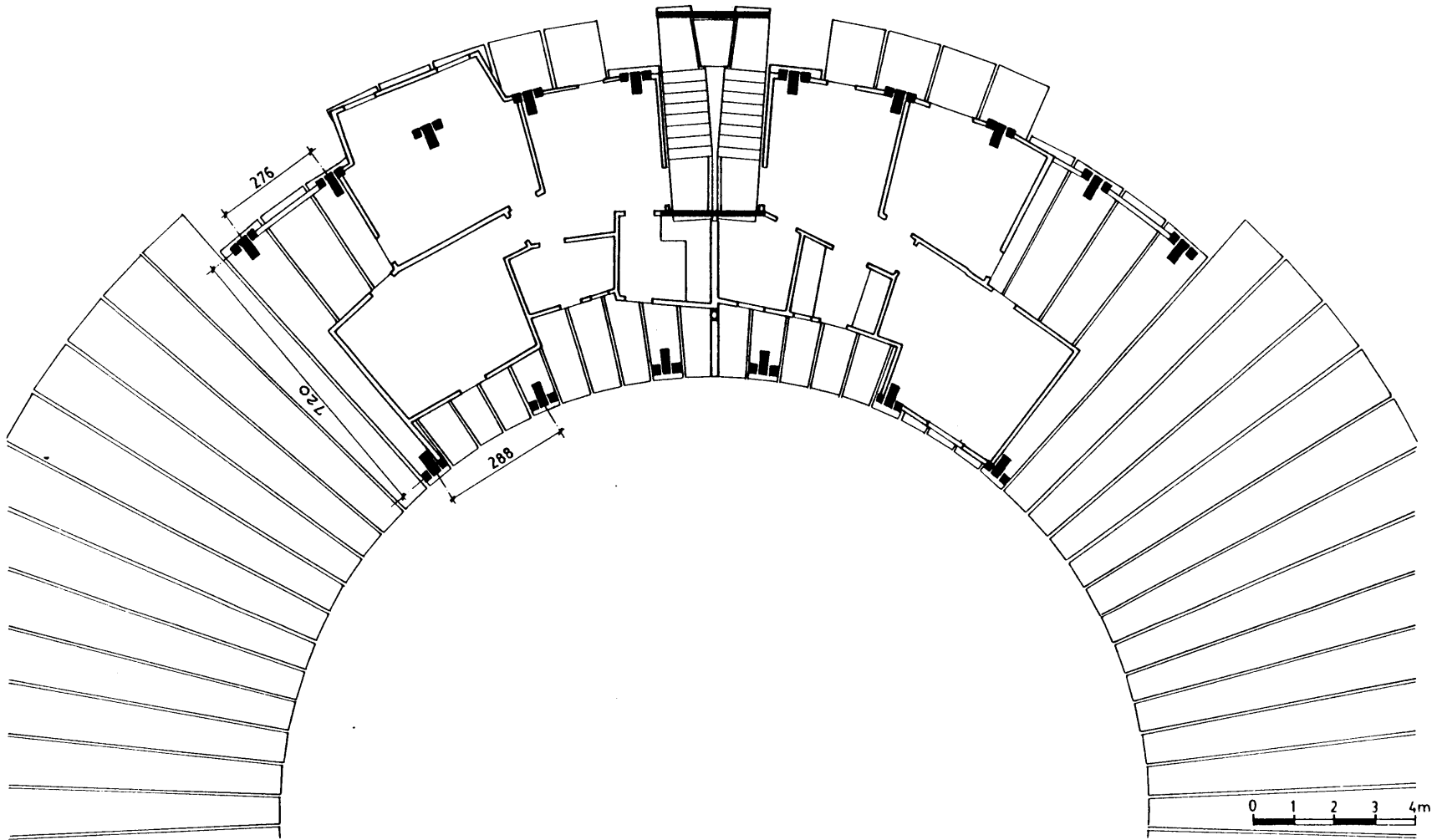

DWG. #23: APPLICATION TO CIRCULAR PLAN / FLEXIBLE UNIT LAYOUTS

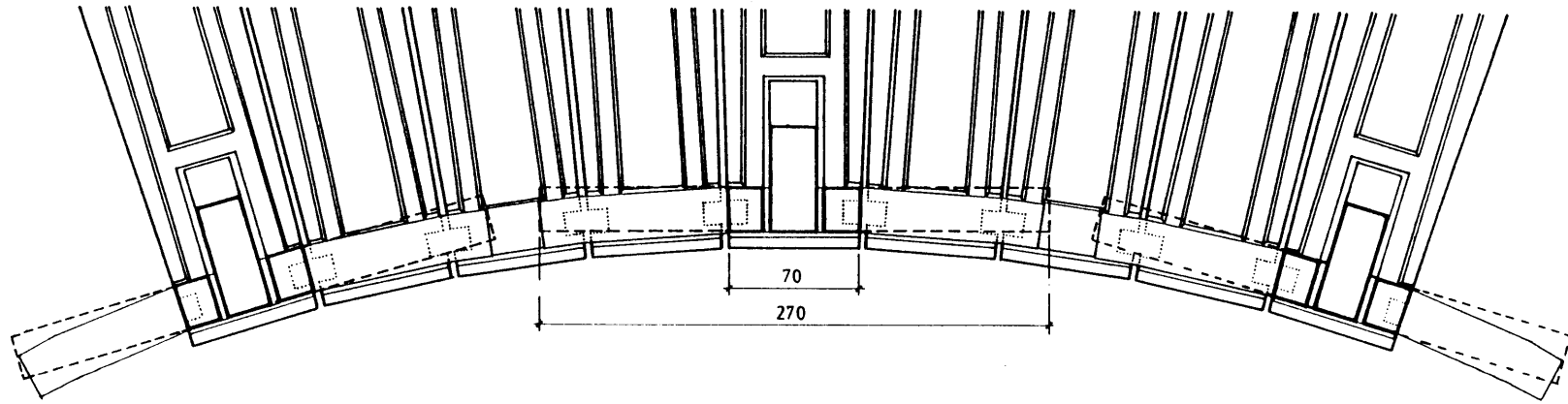
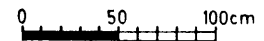
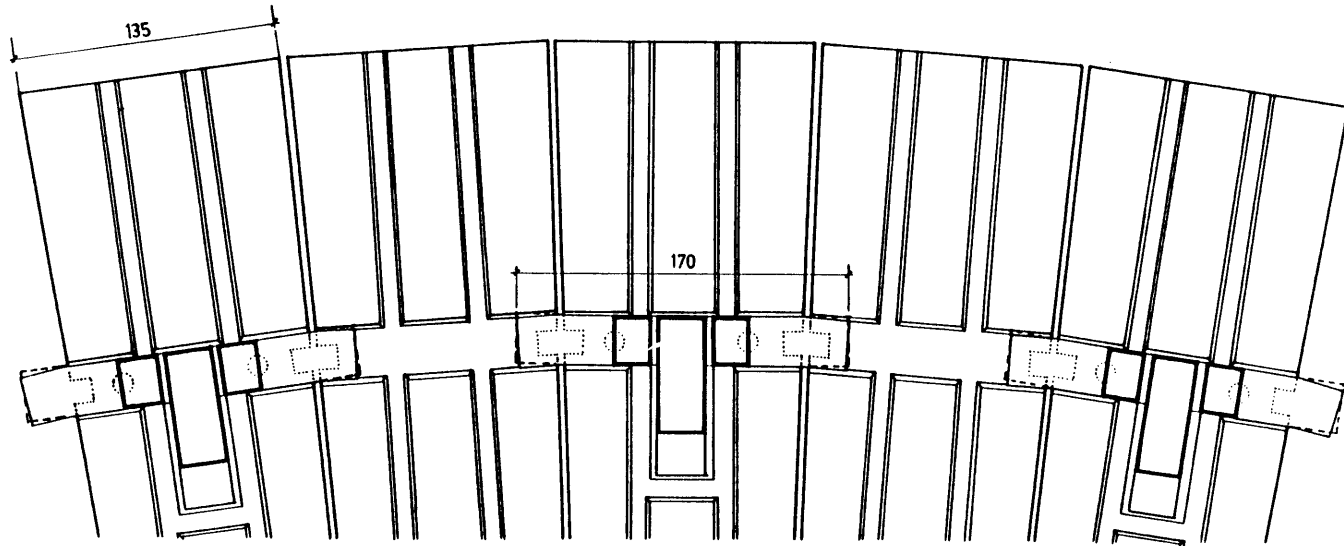

DWG. #24: APPLICATION TO CIRCULAR PLAN USING SL-9

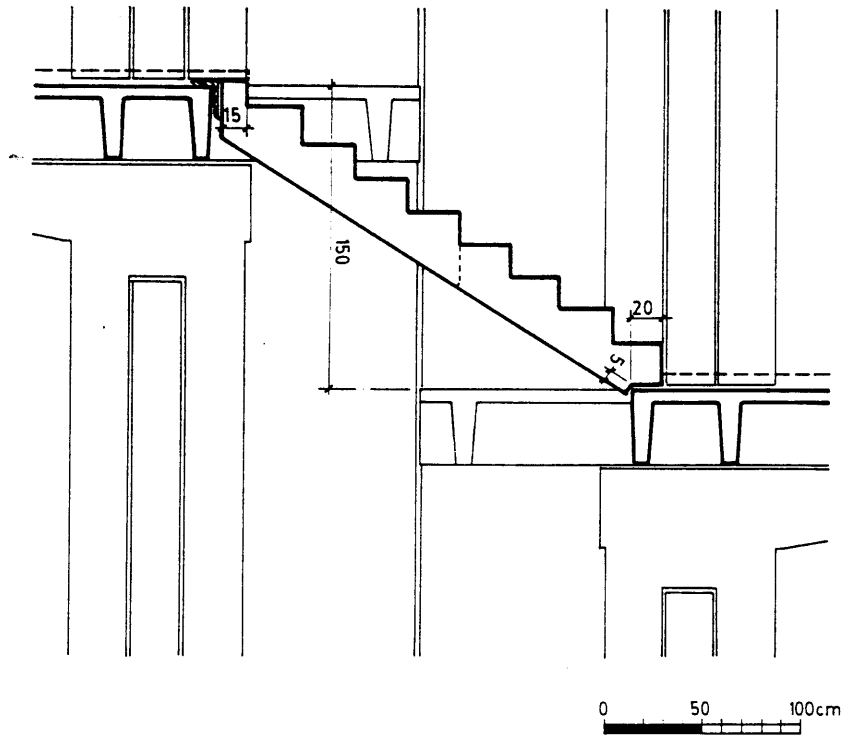
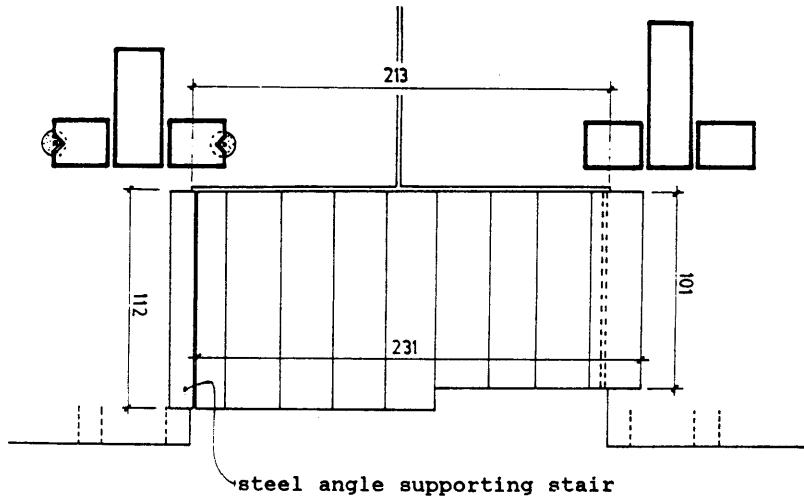

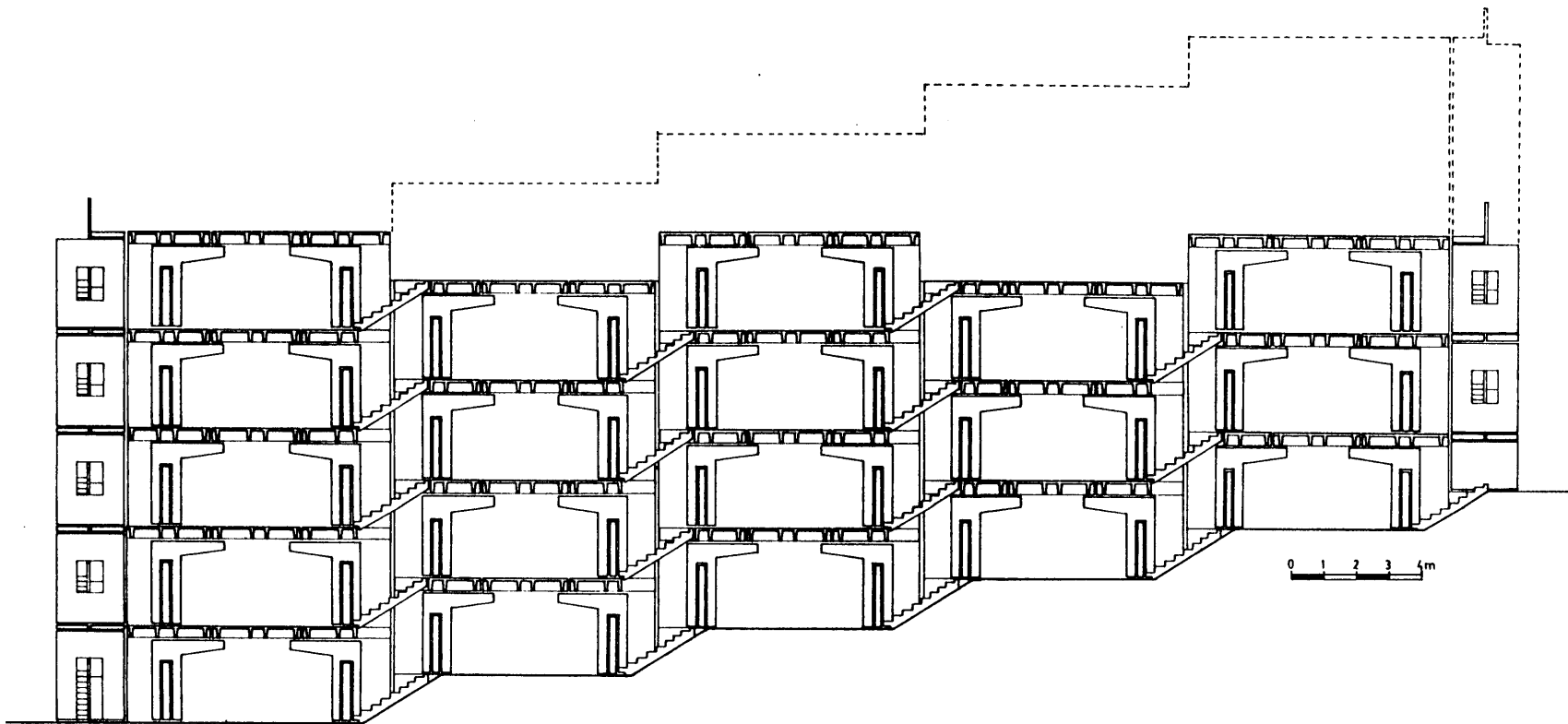

DWG. #26: ADAPTATION TO SLOPES / LONGITUDINAL AXIS

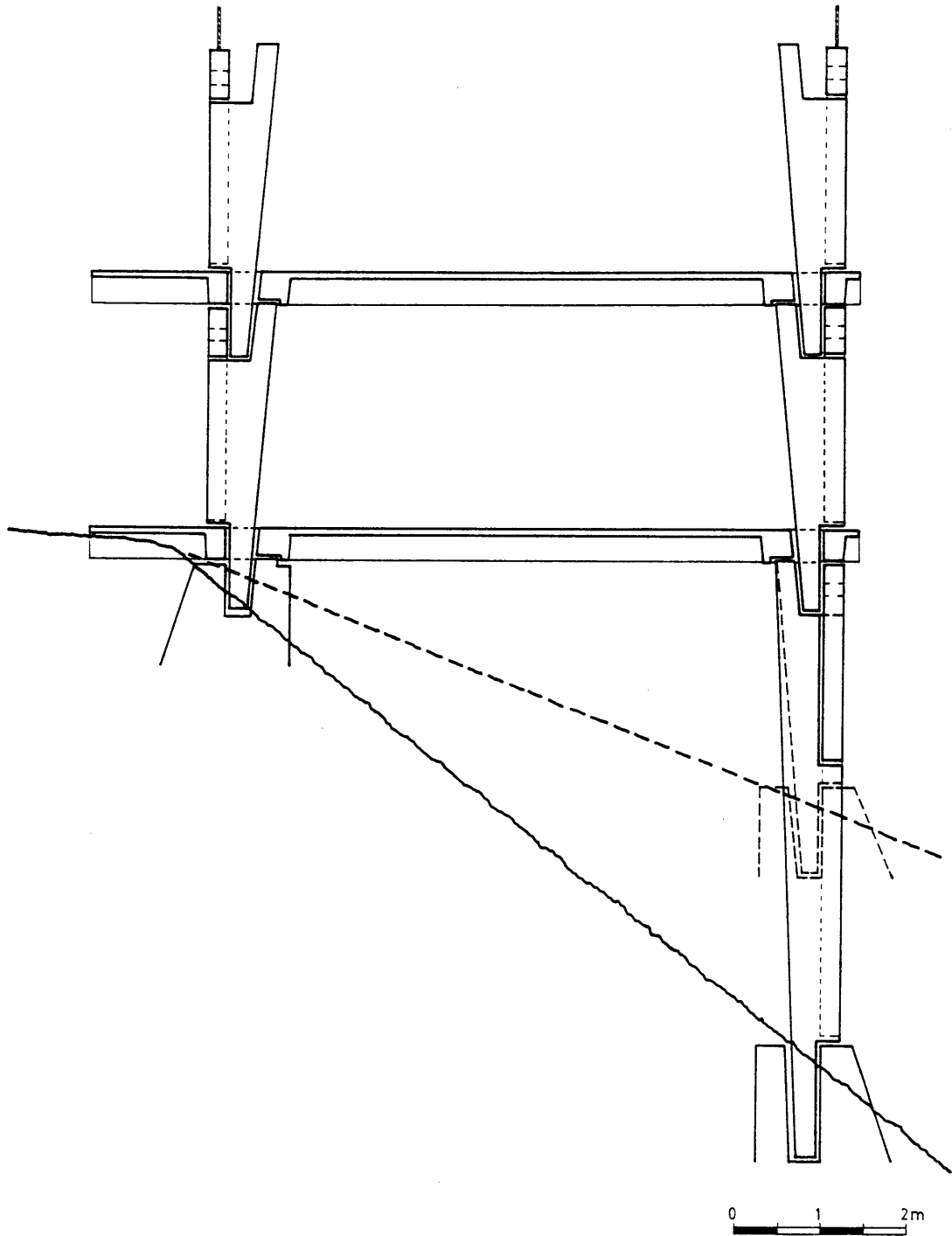

DWG. #27: ADAPTATION TO SLOPES / TRANSVERSAL AXIS

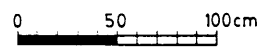
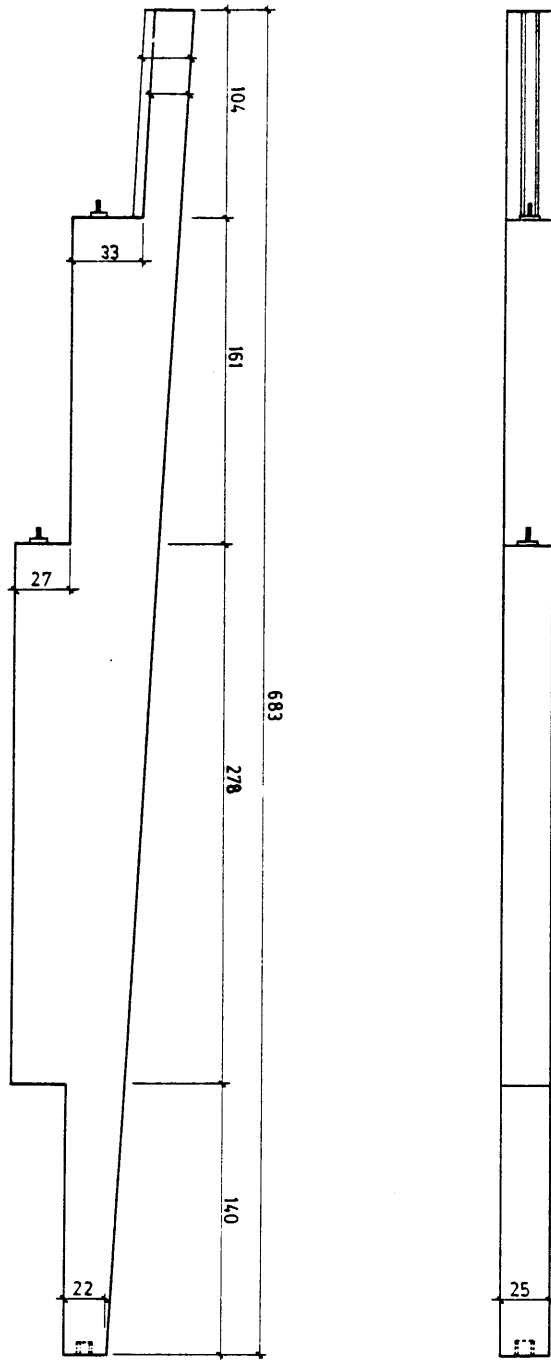

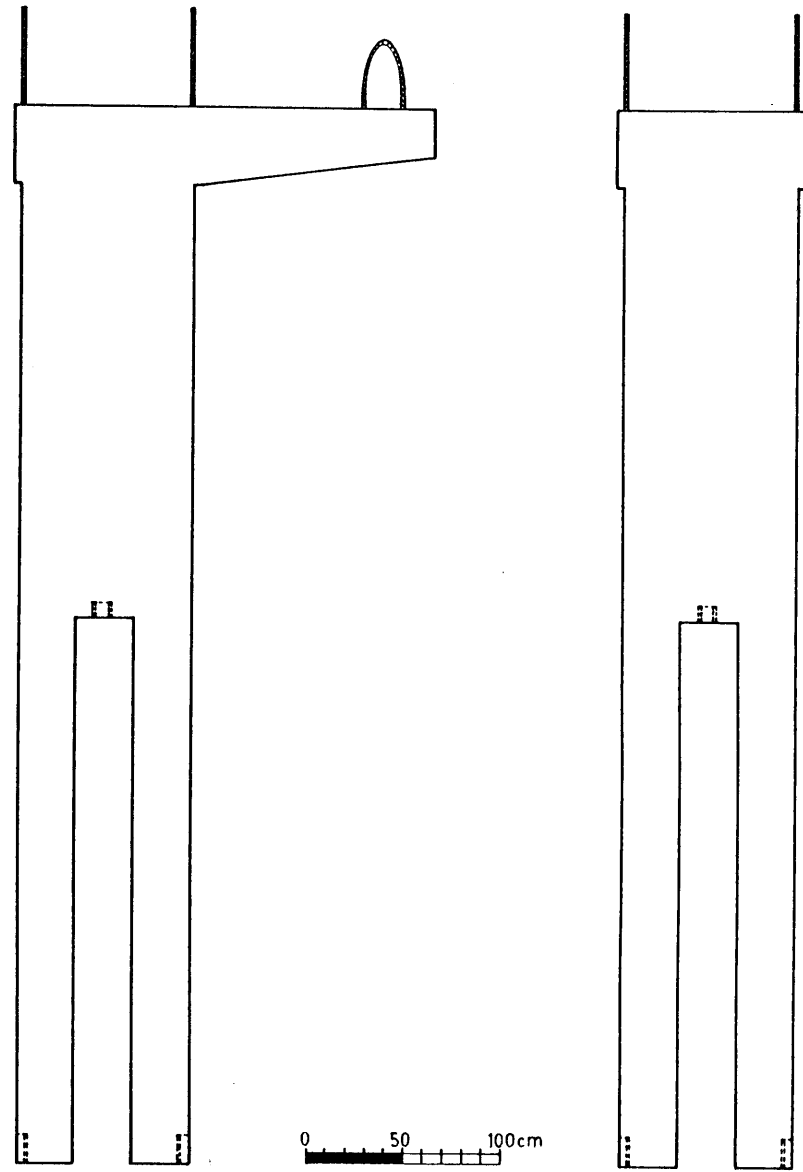
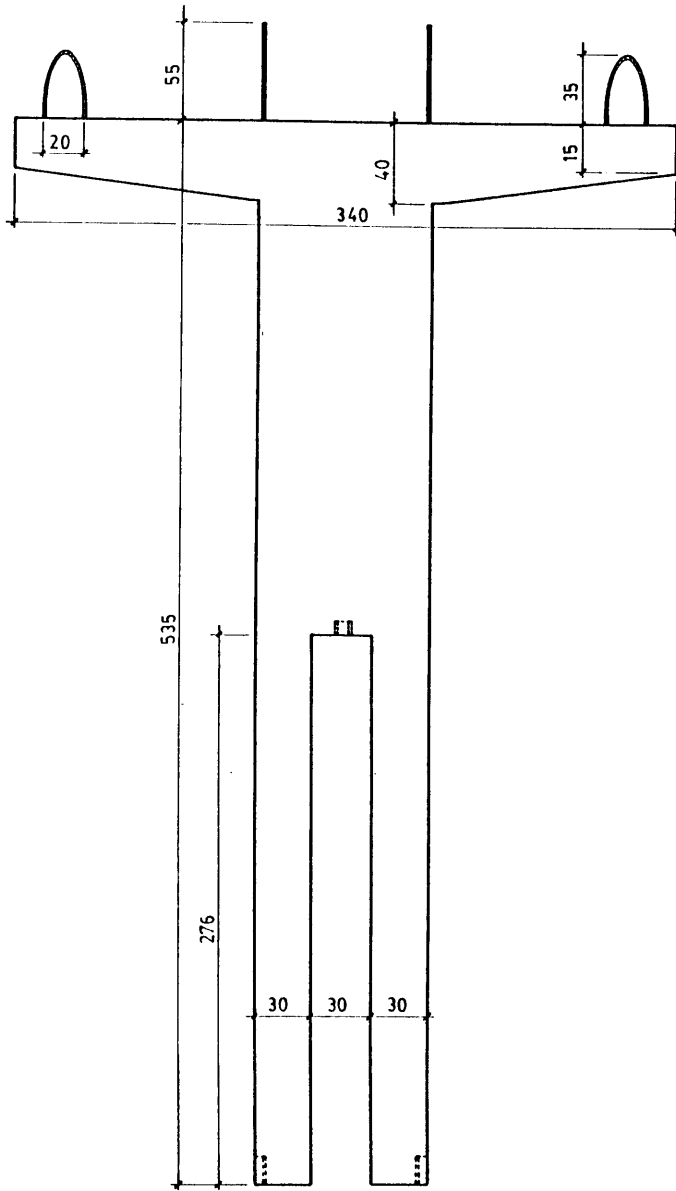

DWG. #29: TWO-STORY COLUMN / VARIATIONS OF C'-2

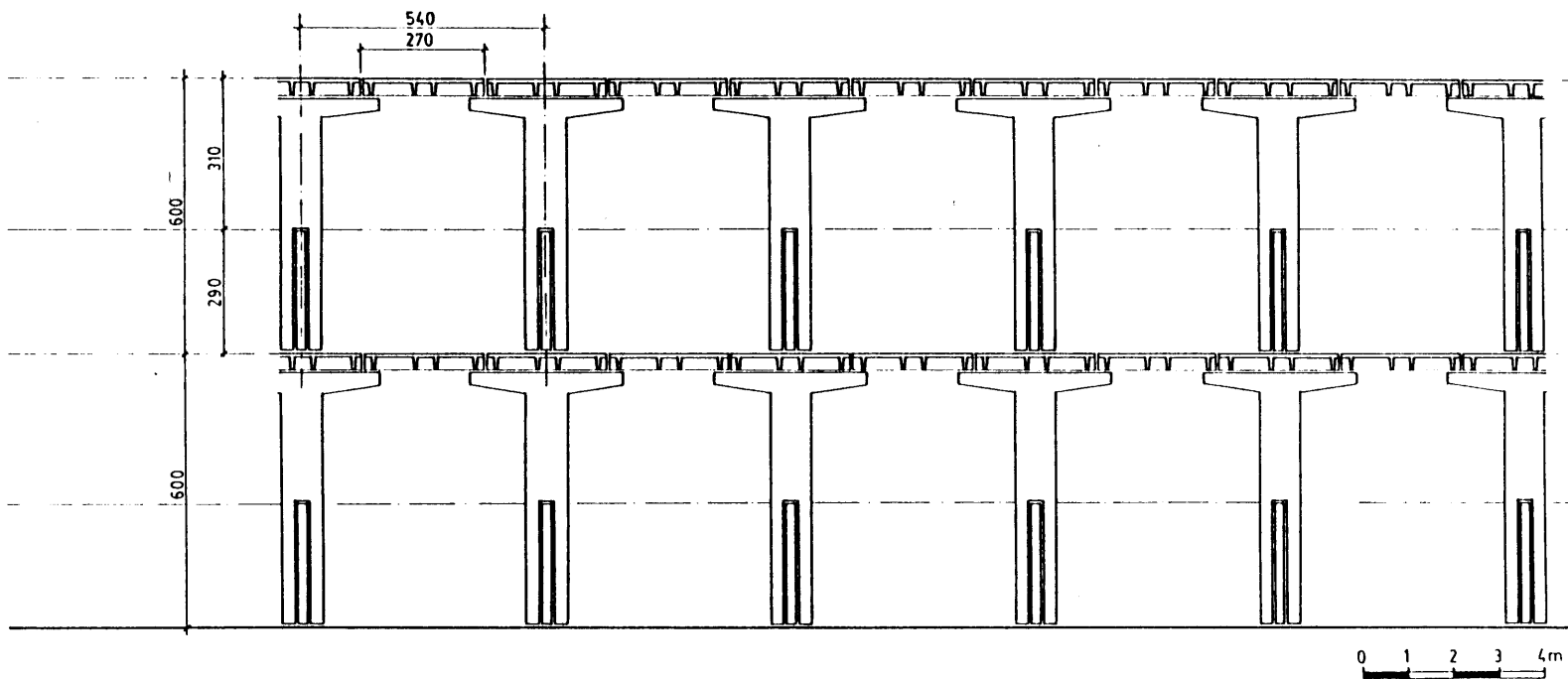

DWG. #30: TWO-STORY COLUMNS / ELEVATION OF STRUCTURE

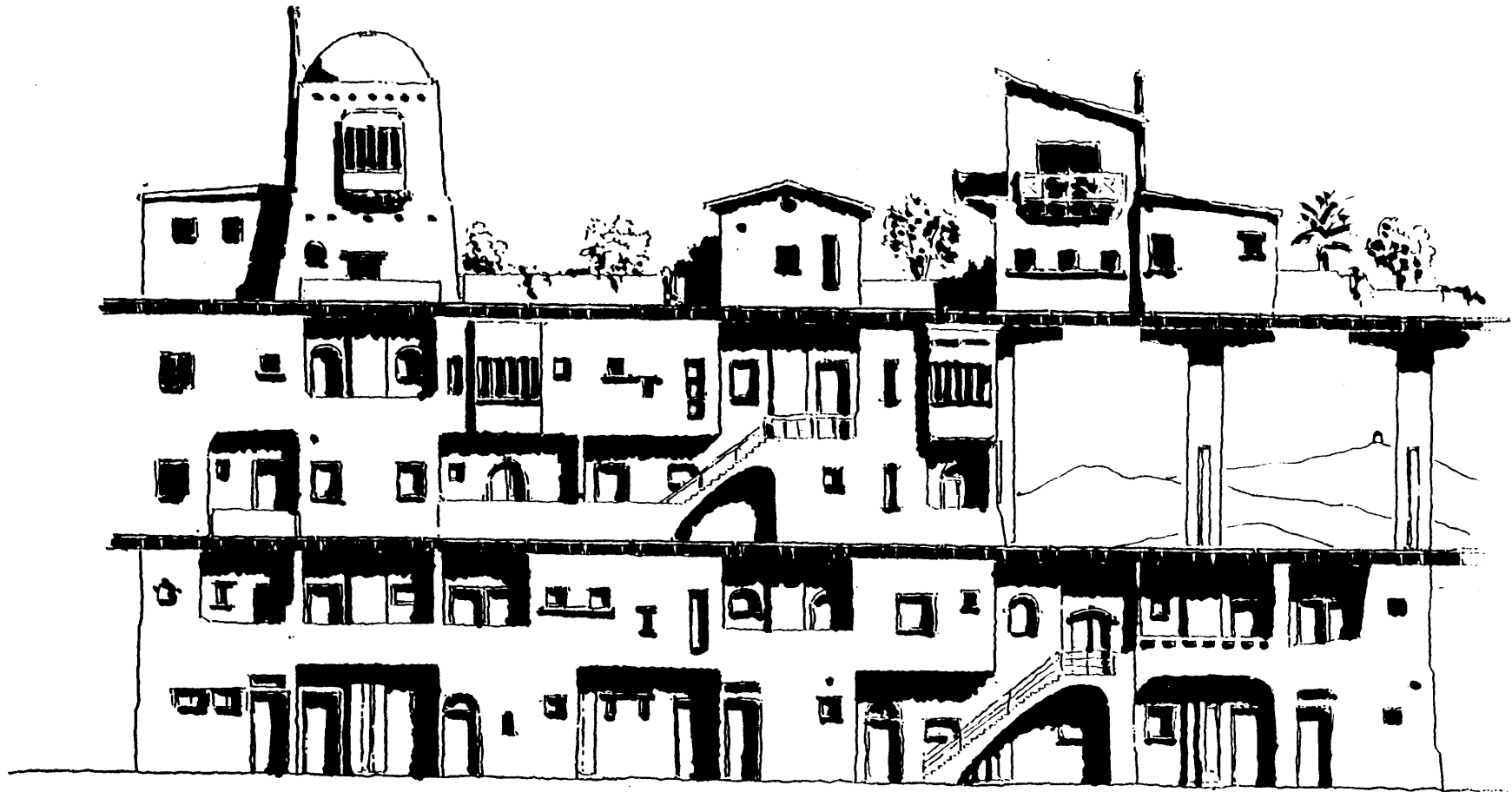

DWG # 31: TWO-STORY COLUMNS / STRUCTURE INHABITED / AN ALTERNATIVE

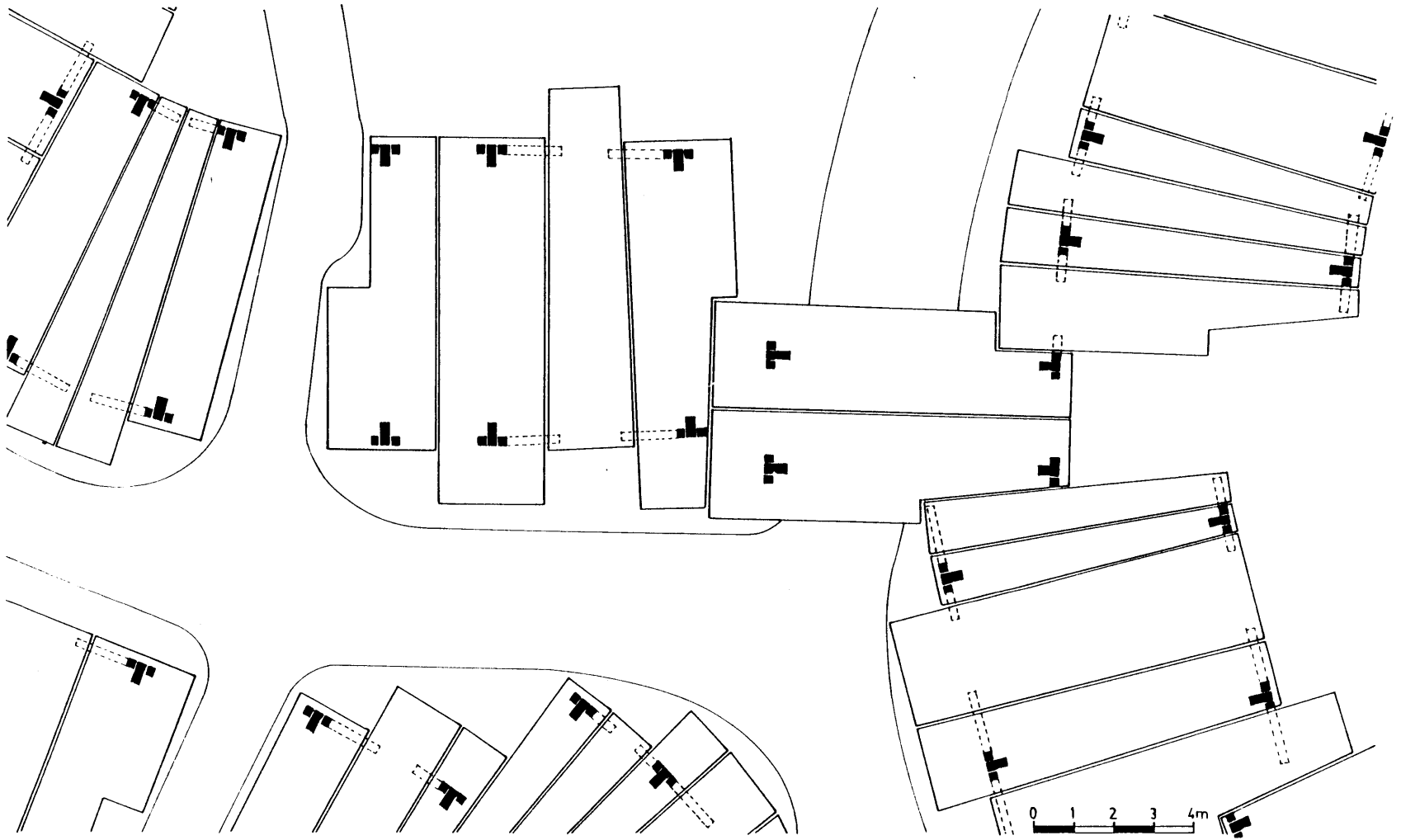

DWG. #32: APPLICATION TO IRREGULAR SITES / PLAN OF STRUCTURE

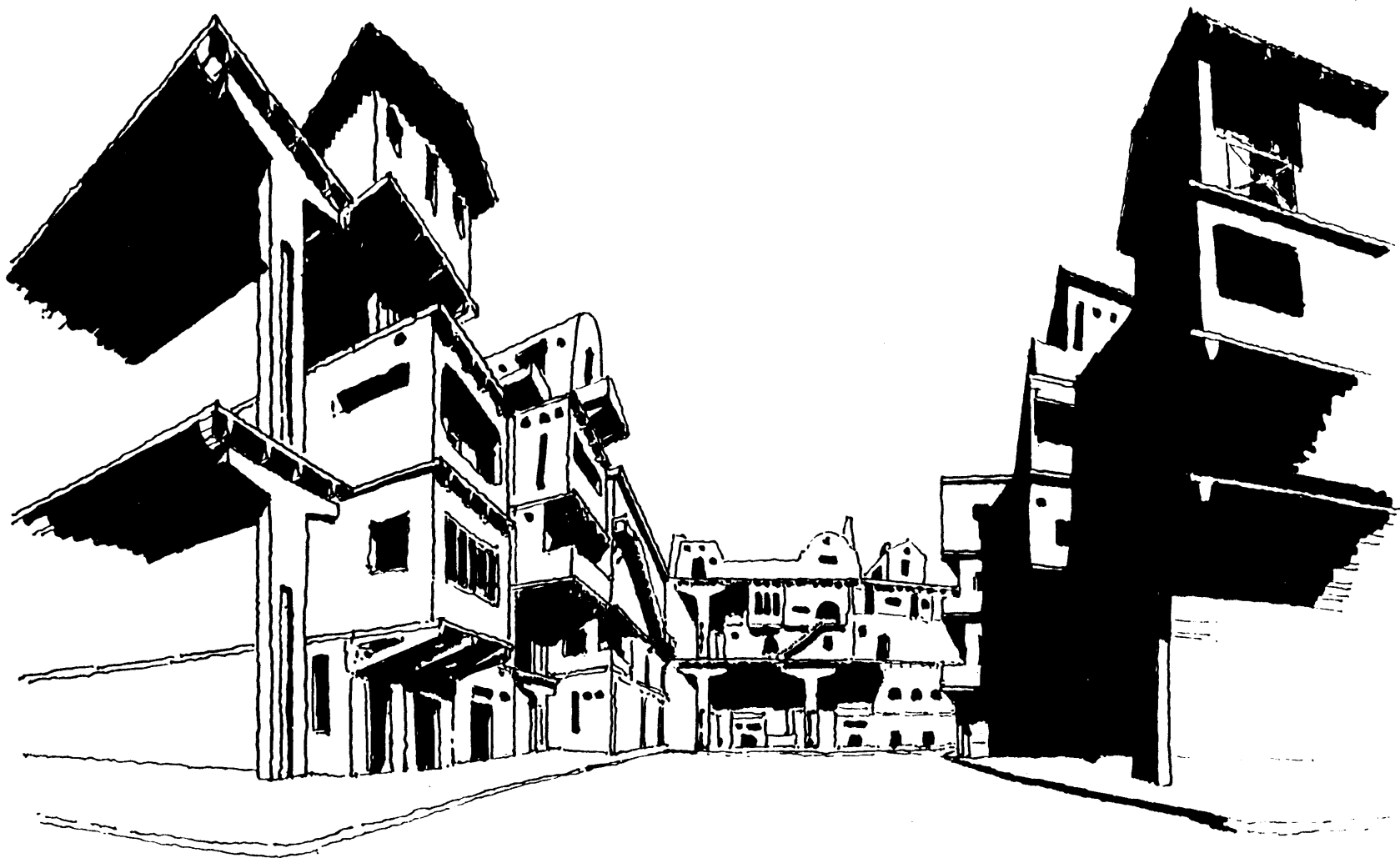

DWG. #33: APPLICATION TO IRREGULAR SITES / PERSPECTIVE

REFERENCES

1. Bender, R., A Crack in the Rear-View Mirror. A View of Industrialized Building, Van Nostrand Reinhold Co., New York, 1973, pg. 6.
2. Ibid., pg. 9.
3. Habraken, N. J., Supports: An Alternative to Mass Housing, The Architectural Press, London, 1972, pg. 48.
4. Ibid., pg. 50.
5. Dluhosch, E., "Strategies for the Design and Delivery of Staged Housing", Dept. of Architecture, M.I.T., Cambridge, 1985, pg. 9.
6. Habraken, N. J., Supports: An Alternative to Mass Housing, The Architectural Press, London, 1972, pg. 60.
7. Dluhosch, E., "Design Constraints of Conventional Prefabrication Systems in Housing", Dept. of Architecture, M.I.T., Cambridge, 1981, pg. 40.

BIBLIOGRAPHY

Bender, R., A Crack in the Rear-View Mirror. A View of Industrialized Building, Van Nostrand Reinhold Co., New York, 1973.

Bender, R. and Parman, J., "The Townland System - An American Framework", I.E., vol. 7, 1976.

Dluhosch, E., "Design Constraints of Conventional Prefabrication Systems in Housing", Dept. of Architecture, M.I.T., Cambridge, 1981.

Dluhosch, E., "Strategies for the Design and Delivery of Staged Housing", Dept. of Architecture, M.I.T., Cambridge, 1985.

Habraken, N. J., Supports: An Alternative to Mass Housing, The Architectural Press, London, 1972.

Habraken, N. J. and Dluhosch, E., "The Role of Industrial Production for Increasing Housing Production in the Low-Income Sector of Egypt", Ekistics 280, Jan./Feb. 1980.

Sullivan, B. J., Industrialization in the Building Industry, Van Nostrand Reinhold Co., New York, 1980.

Cairo University/Massachusetts Institute of Technology, joint research team, The Housing and Construction Industry in Egypt, interim report working papers, Cambridge, 1980.

U.S. Department of Housing and Urban Development, Housing Systems Proposals for Operation Breakthrough, Government Printing Office, Washington D.C., 1971.