

THE MORPHOLOGY OF THE URBAN EDGE:
DESIGN PROJECTIONS FOR A COMMERCIAL STREET

by
Arthur W. Pinkham

Submitted in Partial Fulfillment of the Requirements
for the degree of
MASTER OF ARCHITECTURE
at the
MASSACHUSETTS INSTITUTE OF TECHNOLOGY
January 1982

Signature of Author
Department of Architecture
January 14, 1982

Certified by
Maurice Smith
Professor of Architecture

Accepted by
Edward Robbins, Chairperson
Departmental Committee for Graduate Students

© Arthur W. Pinkham 1982

The author hereby grants to M.I.T. permission to reproduce and to distribute publicly copies of this thesis document in whole or in part.

MASSACHUSETTS INSTITUTE
OF TECHNOLOGY

JAN 27 1982

Rotch

THE MORPHOLOGY OF THE URBAN EDGE:
DESIGN PROJECTIONS FOR A COMMERCIAL STREET

by Arthur W. Pinkham

Submitted to the Department of Architecture on January 14, 1982 in partial fulfillment of the requirements for the degree of Master of Architecture.

The renaissance of the American city is a phenomena of great potential but also one which threatens to destroy the fragile balance of elements that structure the city. In the rebuilding and reoccupation of these urban environments, architects and planners must bear in mind that infusions of new architecture must be carefully knitted into the existing economic, social and architectural context.

This thesis examines specifically how commercial buildings have been, and should be integrated with the existing urban fabric. The design portion of the thesis is the generation of an alternative program and design scheme for a proposed regional shopping mall for the central business district of Pittsfield, Massachusetts. The process begins with a brief investigation into the economic and political history of the mall's development to date, and into an understanding of the principles of shopping mall design as they are currently practised. More importantly it is an investigation of urban architectural vocabularies as they relate to street edges of commercial districts, ranging from the scale of large buildings to that of street furniture. With the help of this information, the design project suggests that the success of new retail development in the American city depends upon the acknowledgement of the public street as the sole organizer of social and economic activities in addition to being a channel for pedestrian and vehicular circulation.

Thesis Supervisor: Maurice K. Smith
Title: Professor of Architecture

A B S T R A C T

First, I would like to thank Maurice Smith, for providing me with a thoroughly deep understanding of the questions posed by this thesis, and of architecture and its relation to life in general.

Secondly, I would like to thank my fellow students Jon Alff, Alan Joslin, Roy Strickland, Charles Triester, and especially Elizabeth Chapman for providing a forum for ideas.

Thirdly, I would like to thank Allan Chapman for providing the opportunities to blend education with the testing ground of professional practice.

And finally, I would like to thank both of my grandfathers, Arthur W. Pinkham for providing the confidence and conviction to bust through tough problems, and Gilbert L. Reeh for providing the inspiration to solve them with a balance of creativity, practicality and sensitivity.

A C K N O W L E D G E M E N T S

ABSTRACT	2
ACKNOWLEDGEMENTS.....	3
PITTSFIELD.....	4
SHOPPING MALLS.....	16
GALLERIAS.....	29
CHESTER.....	37
BERN.....	43
NEWBURY STREET.....	50
OUTDOOR MARKETS.....	56
MULTI-FUNCTIONALITY.....	71
LINEAR CONTINUITY.....	64
FINAL DESIGN	75
ILLUSTRATION SOURCES.....	90
BIBLIOGRAPHY.....	92

C O N T E N T S

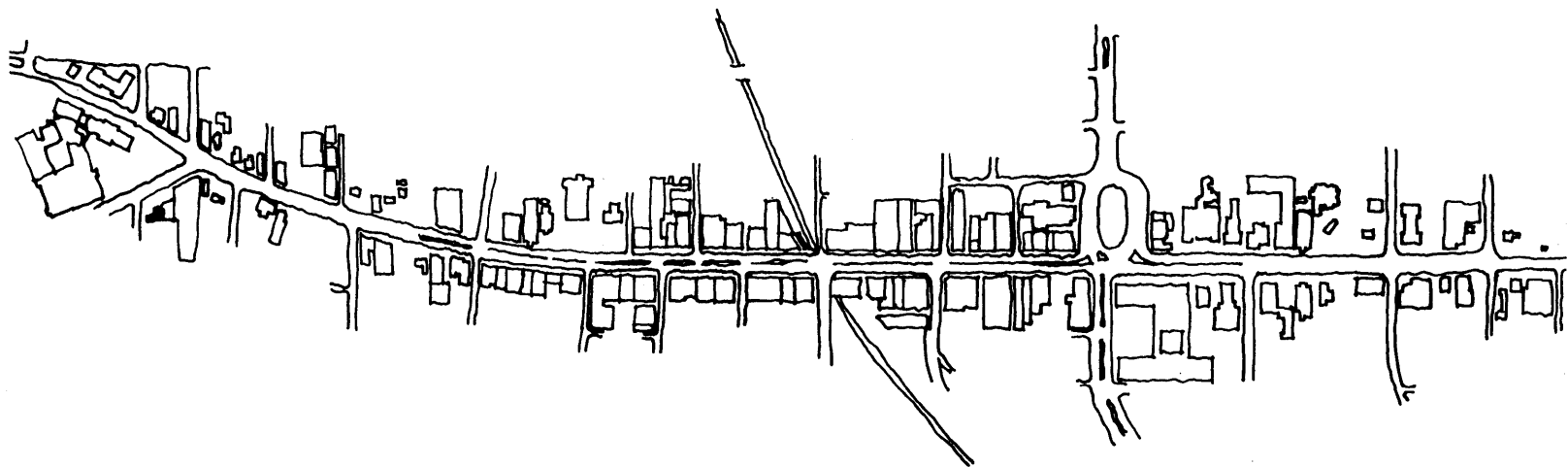

P I T T S F I E L D

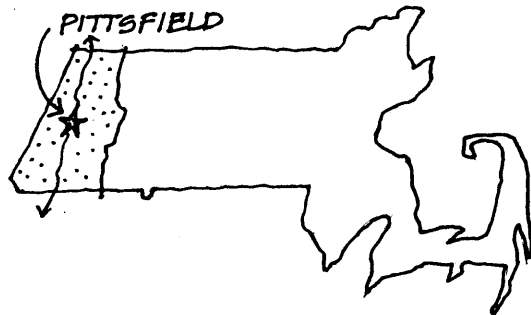

The city of Pittsfield, with a population of about 60,000 full time residents is located in the center of Berkshire County in the western half of Massachusetts. The landscape of Berkshire County, described as a "hideous howling wilderness" by one of the first Englishmen to tramp through its rugged terrain, is most notably characterized by a north-south oriented range of mountains to the west called the Taconics, and a range of mountains to the

6
east called the Berkshire Barrier, forming a valley running from one end of the county to the other and extending northward into Vermont and southward into Connecticut. It is this natural container with its unremitting directionality that organized the major towns and cities of Berkshire County and the movement systems through them.

Dutch and English traders were the first Europeans to arrive in the seventeenth century and expropriate the land from Mohican Indians who had hunted and farmed it for eight to ten thousand years, but it wasn't until the eighteenth century that the Dutch gave up their claims to the area, leaving the English alone to begin the process of civilizing it. Pittsfield in fact, was not established until 1761. As everywhere else, agriculture was the first dominant industry. However, in 1801, Zenas Crane began manufacturing paper in Dalton, to the northeast of Pittsfield, and Arthur Scholfield began producing textiles in Pittsfield. These two industries took advantage of the Housatonic River, the other important landscape element in the north-south organization of the county.

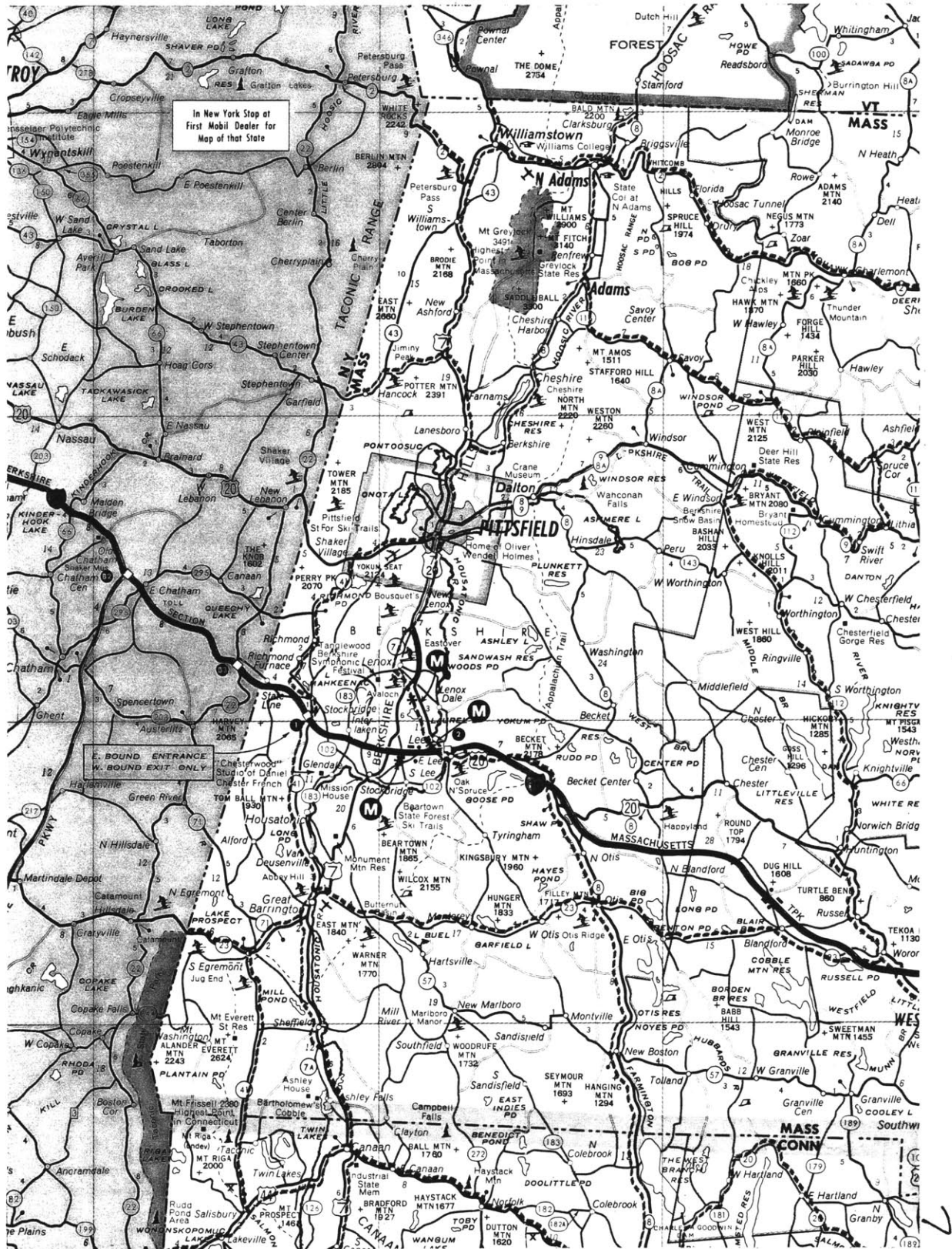

In New York Stop at
First Mobil Dealer for
Map of that State

E. BOUND ENTRANCE
W. BOUND EXIT ONLY

The introduction of the railroad into the county in 1842, combined with technological progress of the industrial revolution established the small urban centers of the county and funneled a wave of new American immigrants into the paper and textile mills that were rapidly growing along the Housatonic. Not only had the main rail line been built through centrally located Pittsfield, but the county seat moved to the new county courthouse there in 1871 and Pittsfield became the regional center of activity linked by a major road, that is now U.S. Route 7, in a north-south axis to other Berkshire communities within the valley. Those towns organized along the road within the north-south valley grew in the nineteenth century and those beyond the valley remain to this day as little farming communities. Without the continuity of the river, the circulation of the valley, and all the associated regional north-south traffic, the outer lying towns could not thrive, nothing established links between them and the public realm of the valley.

Before the Civil War, the rugged natural

beauty of the Berkshire Mountains produced the influx of literary greats such as Hawthorne, Melville, Holmes and Longfellow which in turn attracted the nineteenth century millionaire captains of industry and banking from New York to the Berkshires. Much of the virgin territory was divided into large estates. By 1880 the county had become the "Newport of the Hills", and witnessed the construction of seventy-five mansions and scores of summer houses. Prestigious architectural firms like McKim, Meade and White were imported to design these palaces.

In 1886 William Stanley, a Berkshire inventor brought the modern technology of alternating current power to the county and established with General Electric Company an electrical equipment manufacturing plant on the eastern edge of Pittsfield which grew to become the major employer of the city's workers in tandem with the older, well established paper industry. The introduction of industry outside the city center began the development of the residential suburbs.

The economic failures of the 1920's left

the surrounding region's extravagant mansions mostly abandoned. Eventual conversion of these estates into tourist hotels, country clubs, summer resorts, and summer theater and arts centers attracted New Yorker's of both the leisure and middle classes back to the Berkshires for seasonal recreation. This, in combination with the lure of northern Berkshire and Vermont skiing placed the county along a major touristic corridor between New York and Montreal that was still contained by the north-south valley formed by the Taconics and the Berkshire barrier. The downtown of Pittsfield remained the banking and commercial center of the Berkshire segment of the corridor which was coincident with Pittsfield's single retail zone known as North Street. Pittsfield is the type of American city that grew up around one main commercial street. Housing, offices, hotels, recreational facilities, banks and churches were also organized in reference to this corridor. It was always the site of the city's Memorial Day and Fourth of July parades; thus it was an organizer of both social and economic institutions and



NORTH STREET (FACING NORTH)

events.

The prosperity of the 1950's brought large commercial development in the form of two strip centers to the east and west of the old downtown. The Coltsville mall, a group of modern stores surrounding a Sears Roebuck department store spawned a larger competing commercial zone drawing customers from the adjacent General Electric plant and surrounding residential development. The

other strip center to the west was located on U.S. Route 20 which took advantage of traffic generated by smaller residential zones and some light industry that had grown outside of the city with the advent of truck transport.

Pittsfield has developed into a city with a major north-south axis intersected by a minor east-west axis that provides links to the industrial zone of General Electric on the east side and the state forest on the west side. The city center is punctuated at the north by the Pittsfield General Hospital and dribbles gradually into lower density residential zones about half a mile south of the Park Square ellipse, a traffic rotary that forms the intersection of the two axes. The land slopes westward, to the Housatonic river, and is populated by one and two family dwellings built in the early part of the century. The presence of the city's main cultural and banking institutions on North Street and around Park Square helped the downtown remain healthy well into the 1970's. The only new and competing commercial develop-



PARK SQ. ELLIPSE

ment of any significance was the construction of a hotel, office and retail complex in the middle 1960's called the Berkshire Common. Located on the southwest corner of North Street and West Street, the project's retail establishments never fared well because of their introverted organization.



VIEW OF PARKING LOT on SITE

Pittsfield, as several developers have discovered, is part of one of the few remaining large market areas in America that has not been blessed with a regional shopping center. Since 1967, the city, paired with numerous developers, has been trying to develop a piece of land of about twenty one acres located in the center of Pittsfield's central business district. Much of the site was cleared in the early 1960's along with even



VIEW OF PARKING LOT ON SITE

more adjacent land, for Pittsfield's Jubilee urban renewal project which fell short of replacing all of what it destroyed. Historically, the site had been densely built up with a range of structures including housing, shops and warehouses. After the demolition work of the 1960's, the site was left with eight nineteenth century commercial structures, all facing North Street, backed up by an extensive parking lot. Residents and

users of the demolished buildings built and moved into newer quarters further out near the edge of the city, a process which subtracted from the retail district's market.

In 1967 the city hired Robert Ornstein, a New York City developer to orchestrate the project. Ornstein requested complete demolition of all existing buildings to give the mall complete visibility from North Street. The project fell through when the city council could not muster enough votes to take the existing structures by eminent domain.

In 1971 another developer, George Nutman of Boston, was hired. His proposal failed to tie down commitments from department stores because his solution for parking included a number of multi-level garages. This tactic has, according to developers, doomed a number of inner city malls because of the rape syndrome (discussed later).

In 1975 the Berkshire Housing Development Corporation teamed up with Anderson, Notter and Finegold of Boston to develop a mall that would incorporate one of the department stores into the old Renaissance revival structure on

12
the corner of North and West Streets now occupied by the Pittsfield National Bank. Initial cost estimates seemed promising but other associated developers refused to go along with it because of dissatisfaction with the limited visibility from North Street, a problem created by other existing buildings.

Once again in 1976, the Corland Corporation associated with RTKL associates of Baltimore tried and failed to develop the project because of the required reuse of the existing buildings.

In summary, the success or failure (in terms of economic feasibility as defined by developers) of a conventional mall hinges on the issue of visibility or image of the mall and its parking. As developers see it, the image of a nineteenth century downtown center does not have the drawing power of a metal box with a department store sign on it. How then does one explain the retail success of Faneuil Hall or Ghirardelli Square and the Cannery in Boston and San Francisco respectively?

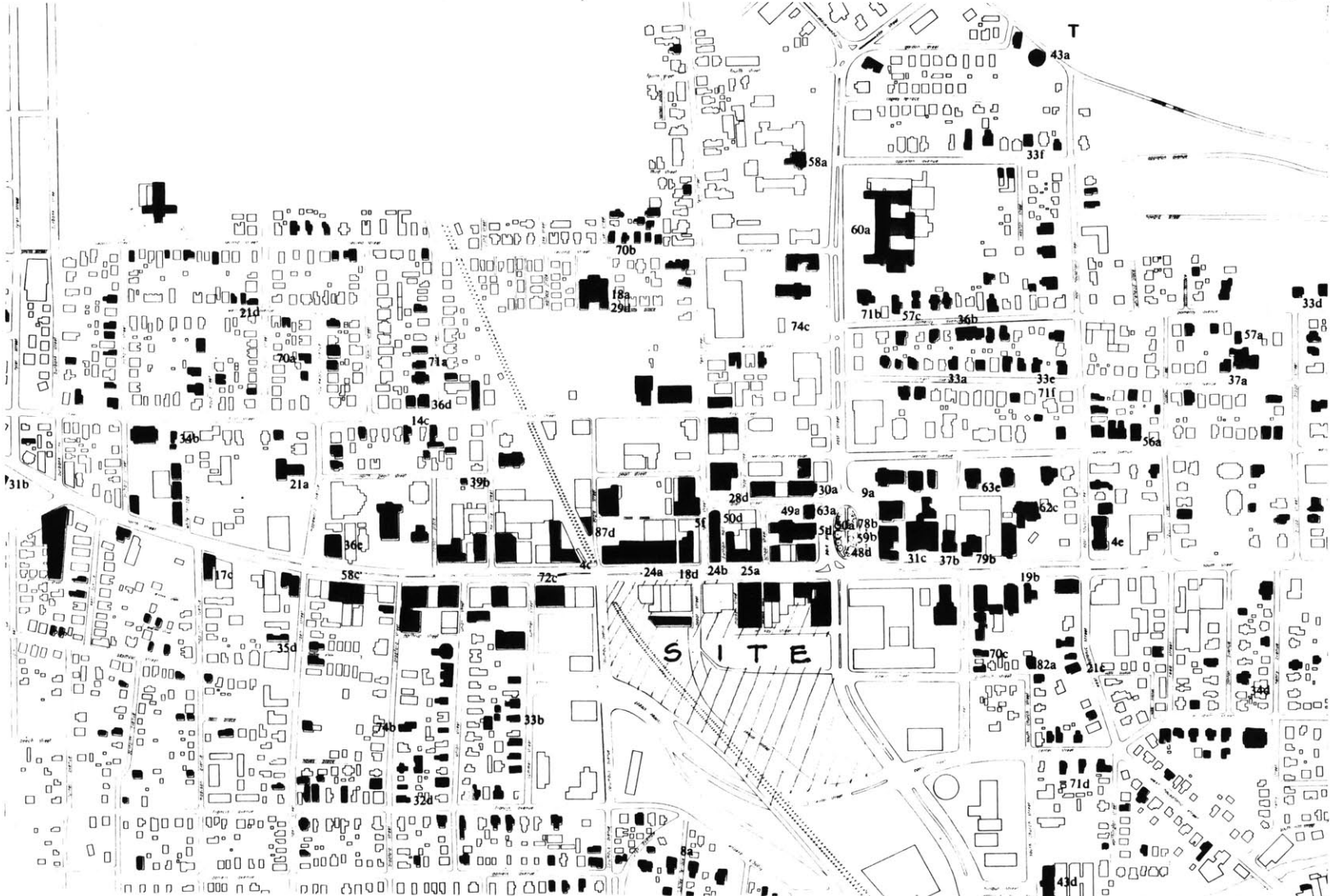

PLAN OF DOWNTOWN PITTSFIELD

The current story, with the Pyramid Companies playing the role of the developer, begins in 1976 when Pyramid acquired an option on a piece of rural land in the neighboring town of Lenox, on which Pyramid proposed building a 500,000 square foot mall. This proposal threatened the success of any future commercial development in the city of Pittsfield and any ongoing success of the city's existing merchants. Fortunately for the city Governor Dukakis, who was urging the redevelopment of Massachusetts' city centers, refused to grant permission to make curb cuts to Pyramid and effectively drove the project into the city. However, what at first appeared to be a blessing quickly developed into a nightmare when Pyramid unveiled its new design plans. Based on market studies and the knowledge that two other developers had recently acquired options on land in other communities for the purpose of mall construction, Pyramid concluded that their mall had to be big enough to destroy anybody else's intentions of building outside the city. The project was pumped up to have 710,000 square

feet of building area and 630,000 square feet of leasable area. The program called for five department stores ranging in size from 100,000 to 80,000 square feet, along with eighty-five smaller stores of 2,000 to 4,000 square feet each. One local department store, England Brothers, who are already on the site in one of the existing buildings was given one of the department store slots and the four others were expected to be taken by J.C. Penny, Filene's, Jordan Marsh, and Sear's Roebuck. The other merchants on the site or within the central business district were kept out of the contracts because Pyramid prefers to sign up only nationally franchised retailers since the price of the new leasable area would be substantially higher and affordable only by larger outfits.

The next problem involved the Pyramid parking solution. They determined that the entire site had to be built up with a 21 acre, three level parking deck instead of much denser, less offensive under and above ground garages. Their reasoning was based on the fact that housewives, who make up the majority of

shoppers, are afraid of underground garages because of their dark, concealed, unprotected corners, stairs and entrances, and that parking must also be very visible from the road to aid the out of town impulse shopper. The developers also wanted the parking to be free, as it is in the suburbs, and requested that the city apply for an Urban Development Action Grant to build the deck. The city received the grant; however, it did not cover the cost of maintenance and operation which would be the city's responsibility.

At first Pyramid requested that all existing buildings on the site be demolished so that the mall would be highly visible from the street. All of the buildings were eligible for National Historic District Registration and after much reaction from townspeople and preservationists Pyramid agreed to keep the facades of two buildings. Shortly thereafter two others mysteriously burned down and the last important building was seen to be too much of a visual blockade on the site.

The organization of the mall itself completely disengaged it from the city context

15
and the materials and mode of construction were completely unsympathetic to the scale and degree of spatial definition typical of the rest of the city. For the number of stores that are actually within the mall there are very few entries and from this it is clear that it is the intent of the developer to create a major discontinuity with other existing shops. The developer argued that local merchants would increase profits through extra traffic and business generated by the mall, however, the "ideal" climatically controlled environment would be stiff competition for other conventionally located stores in a city that often experiences the extremes of weather. The location of parking was also a factor. It's sole concentration around the mall would make trips to other retailers undesirable. In summary, Pittsfield had been blackmailed into accepting the mall. If they didn't, one would be built on the edge of town and the central business district would be destroyed.

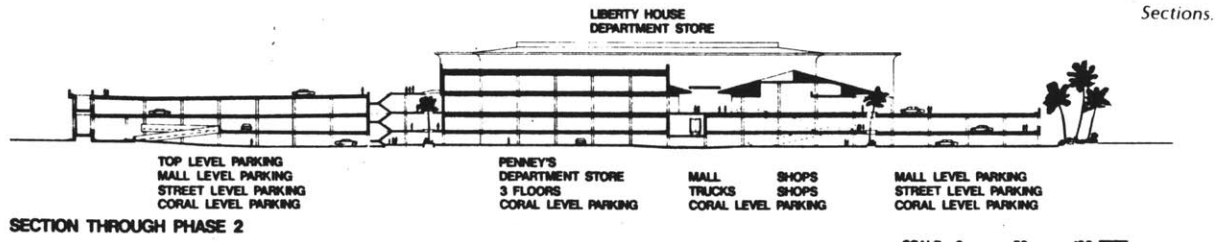
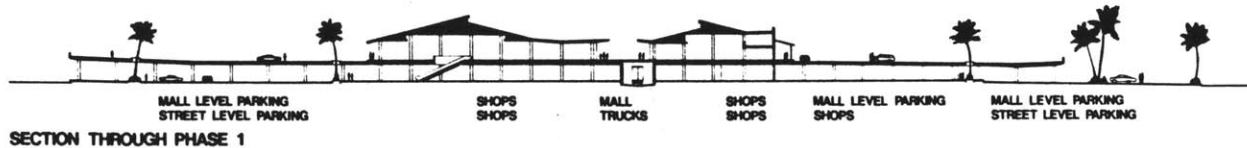

SCALE 0 50 100 FEET

(2)

SHOPPING MALLS



SUBURBAN HOUSING

(3)

The regional shopping center is a building type that is exclusive to the second half of the twentieth century. It is an institution that developed as a byproduct of America's automobile oriented planning concepts. After World War II, America's GI's came home with the desire to settle in the vast open spaces that still existed within relatively short distances of the urban cores. Cheap land, low interest loans provided by the GI bill, and cheap labor and materials costs yielded the materialization

of these desires. The automobile, the telephone, and the television allowed the physical separation of these modern residences from workplaces, markets, and in fact all other institutions. Thus America became, and still is, a functionally zoned landscape tied together by a network of highways and electronic communication systems. The regional shopping center is the highly separated market structure in this strung out discontinuous suburban landscape.



RETAIL ZONE IN A SUBWAY SUBURB

SHOPPING CENTERS: THE GRADUAL DISSOCIATION FROM THE STREET.

Residential buildings, specifically the single family dwelling, were the first to populate the suburban areas of America. Initially commercial districts remained inside the old urban cores but functioned poorly because suburbanites could not find parking spaces in the city when they drove in to shop. Retail businesses then began locating on major

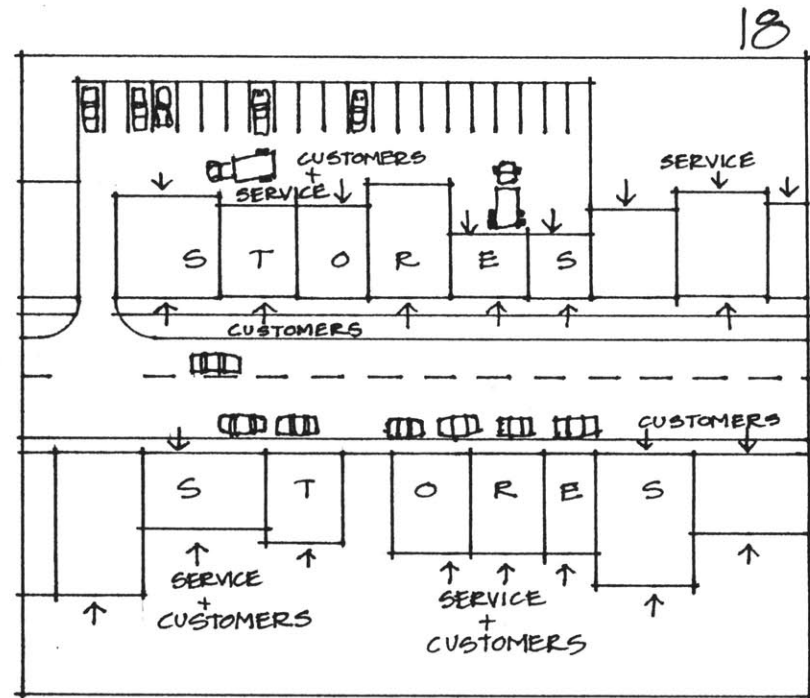

arteries in the suburbs to form what is now unaffectionately termed "strip developments". In some street car suburbs strip developments started out with stores remaining on the street. The absence of housing on top of and behind the stores provided space for small parking lots behind the stores from which both shoppers and service activities entered.

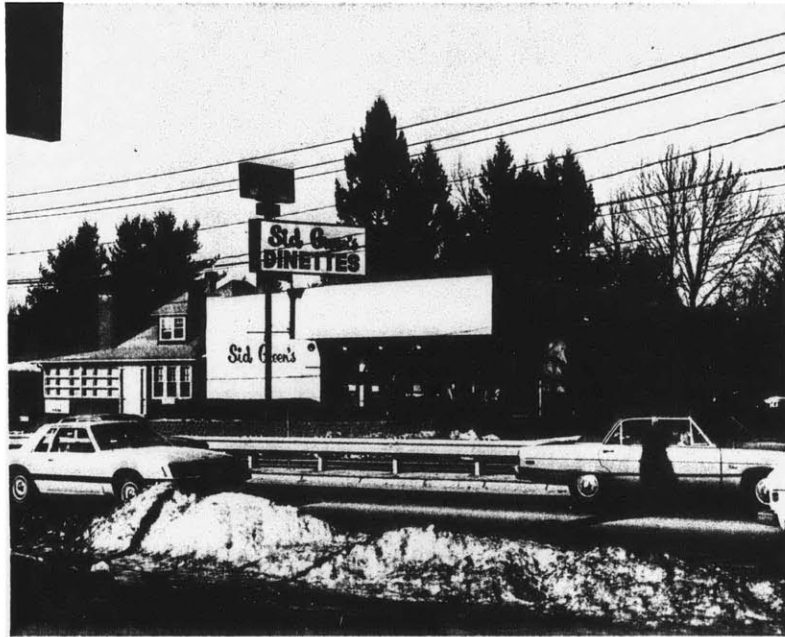

STORE AS OBJECT

As automobiles became more numerous in areas beyond the territory served by public transportation, more parking was required for each business and commercial buildings became dissociated from each other. Shortly thereafter buildings were pulled back from the street to provide parking in front of the building so that shoppers entered the front and service and deliveries went in the back.

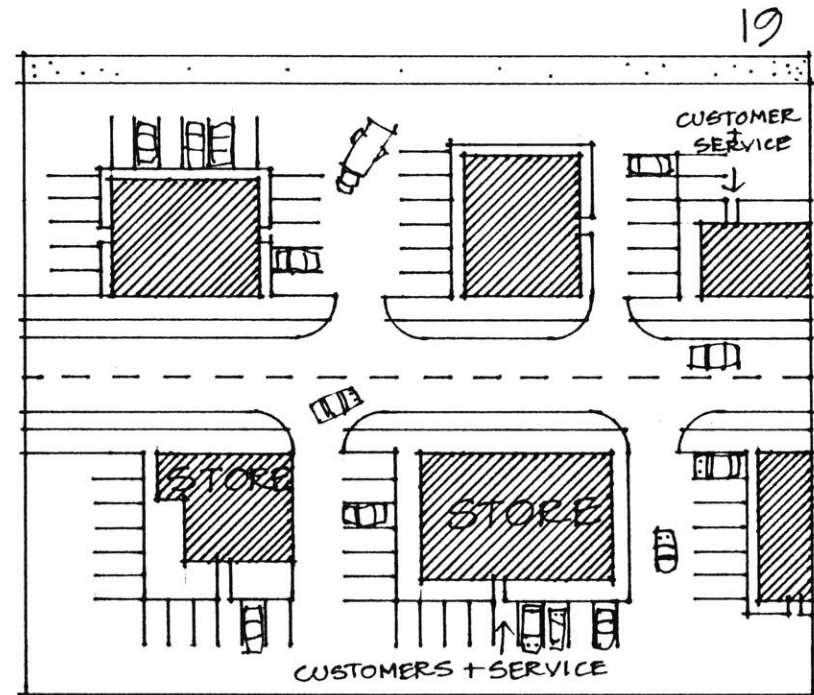

A COMMERCIAL STREET defined by object buildings, a hybrid type with an urban scale that is in between that of the pedestrian world of the city and the auto world of the suburb. Street facing store-front windows lure non-existent pedestrians while big signs are the elements that really attract people in cars.



STORE ISOLATED FROM STREET

The 'street' has lost its traditional formal qualities as buildings have pulled away from it. It is now merely an artery of vehicular circulation rather than a place in which activity

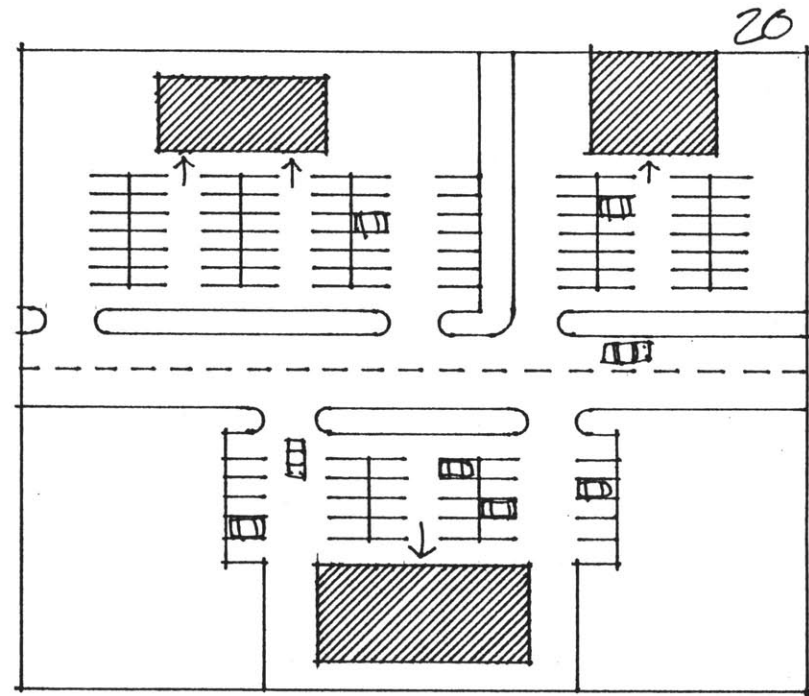

THE 2-DIMENSIONAL STREET

occurs. 'Architecture', in this context, becomes meaningless because perception by people in speeding cars is limited to the recognition of large scale signs and symbols.



THE STRIP CENTER

Eventually it became apparent that driving from one store to the next was as much of a pain in the ass as not being able to find a parking spot in the city. Consequently, the strip center, a collection of six to twelve small stores, associated with a supermarket, developed. Pedestrian circulation from store to store took

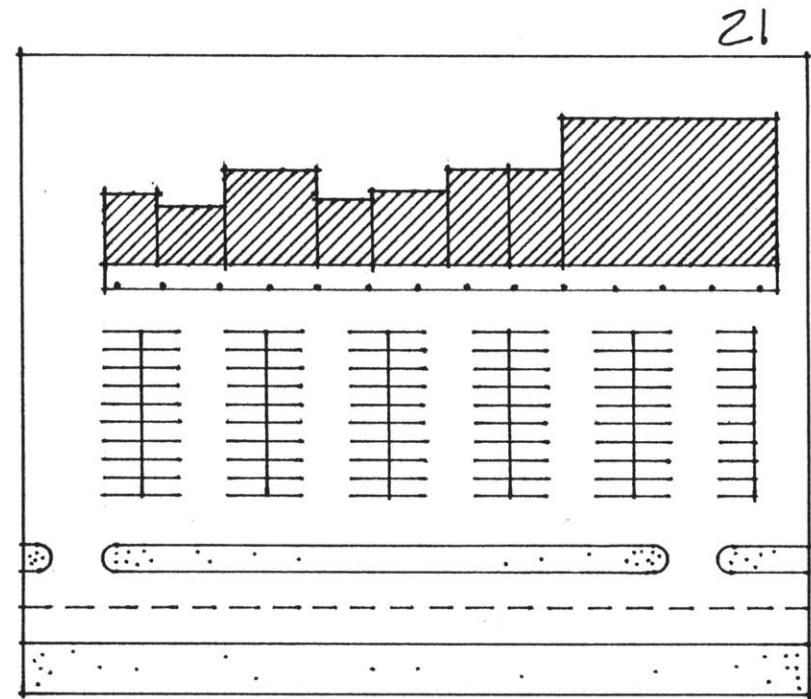

A SEA OF PARKING between street and buildings

place under a canopy that ran the length of the strip. Although customer parking occurred in front of the stores, the strip center still focused its display windows out to the street, a somewhat meaningless gesture in that nobody driving by in a car at 50+ MPH could see what was behind them.

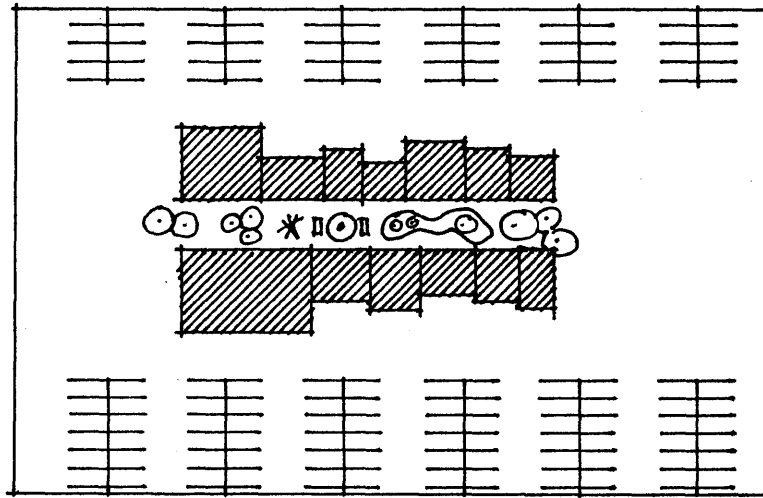

THE LANDSCAPED STRIP

The next concept to develop was the open landscape in between two strips. Access to each store could be gained through doorways from either the parking lot side of the building or the landscape side. This double entry condition created a conflict between customer and service access, required cashiers in two locations instead of one, and rendered the landscape zone inactive. This double strip concept, referred to as an extroverted plan, evolved into an introverted one. Service access was gotten via the parking lot, and shoppers entered via the landscape zone.

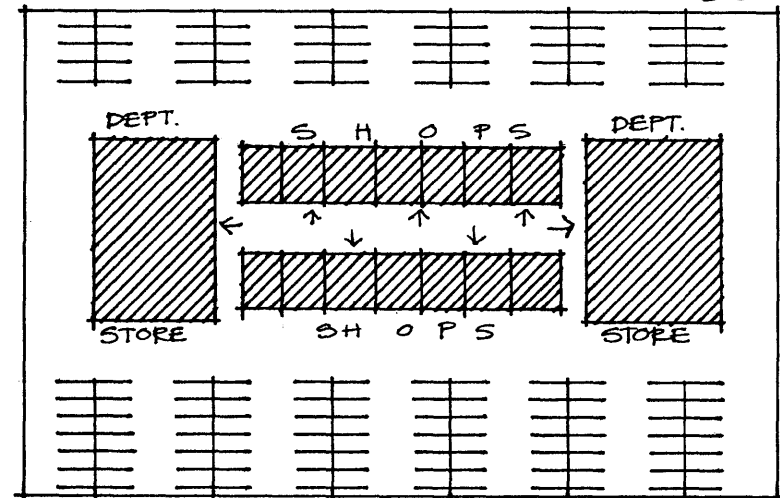

THE 2 ANCHOR MALL

At about this time department stores from the urban cores got into the act and started associations with specialty shops to form "single anchor" and "double anchor" shopping malls. The inner pedestrian circulation zone became "climatized" and the specialty stores located between the anchors got rid of their doors and windows allowing for freedom of movement from circulation areas into stores and back out again. Service became a separate network located in the basement, that never interfered with the customer's path from his car to the store. The type eventually grew in-

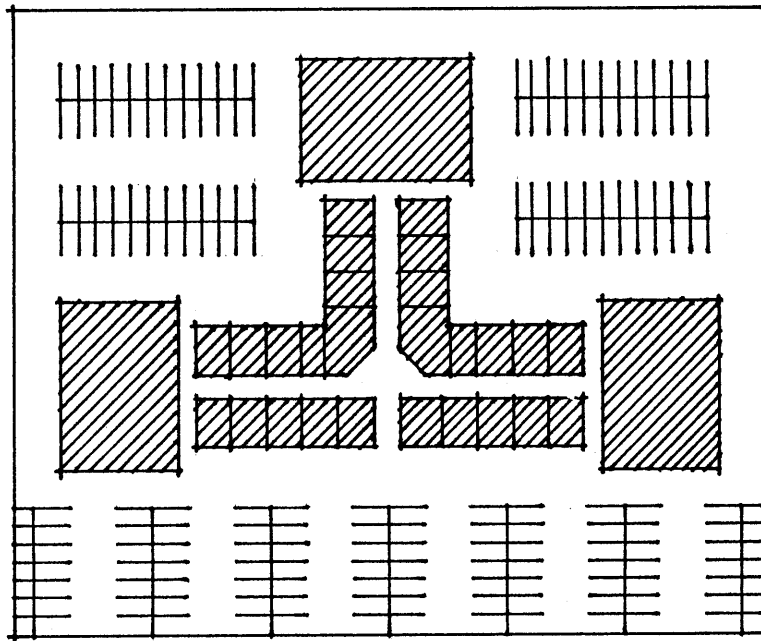

3 ANCHOR MALL

to three and four anchor malls with tee and cross organizations respectively and what was originally a one level configuration has grown to two, three and four level organizations to maintain an acceptable distance between anchor tenants and dramatically increase the number of stores that may front on the pedestrian

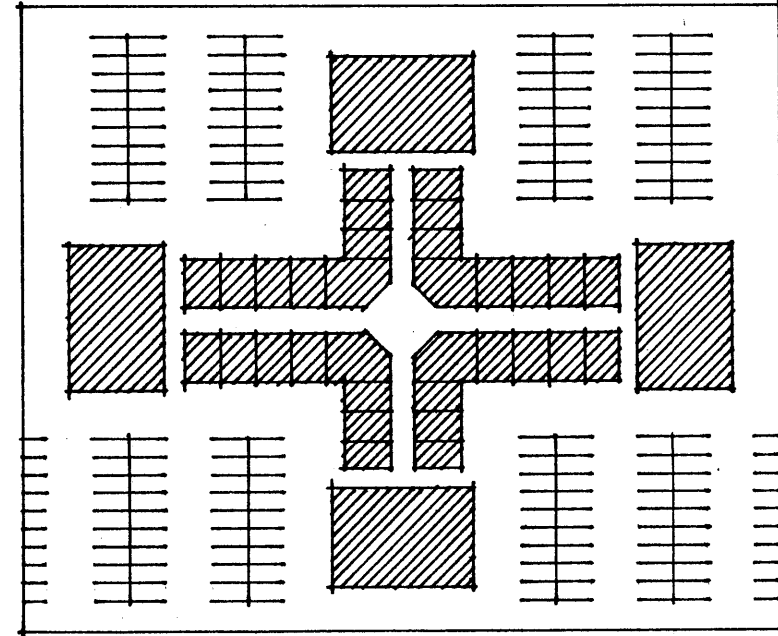

4 ANCHOR MALL

street. At this point the shopping center as a formal type had reached an evolutionary block. The typical mall had successfully dissociated itself from the street which at this point had become a super highway in a landscape of other equally internalized or introverted buildings.

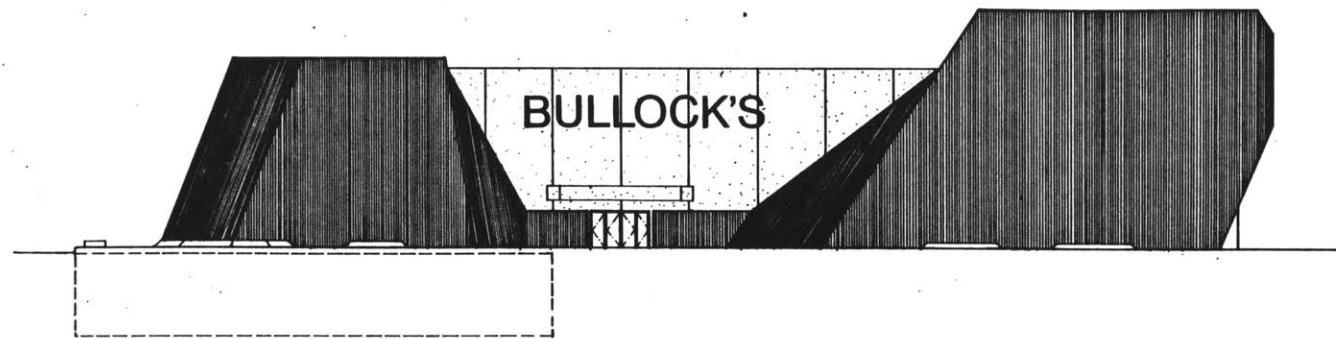

(4)

The architectonics of the malls developed in concert with this notion. Facade treatment of the anchors became excessively blank; signage, which had taken over the role of the shop window display and become scaled to be read by passengers of speeding autos had all

but disappeared. Identification of the center was limited to the names of the anchor tenants pasted on the facade of the store, usually a boxlike structure that looked like a gift wrapped Christmas present. This was enough of a symbol to say "Shopping Center".

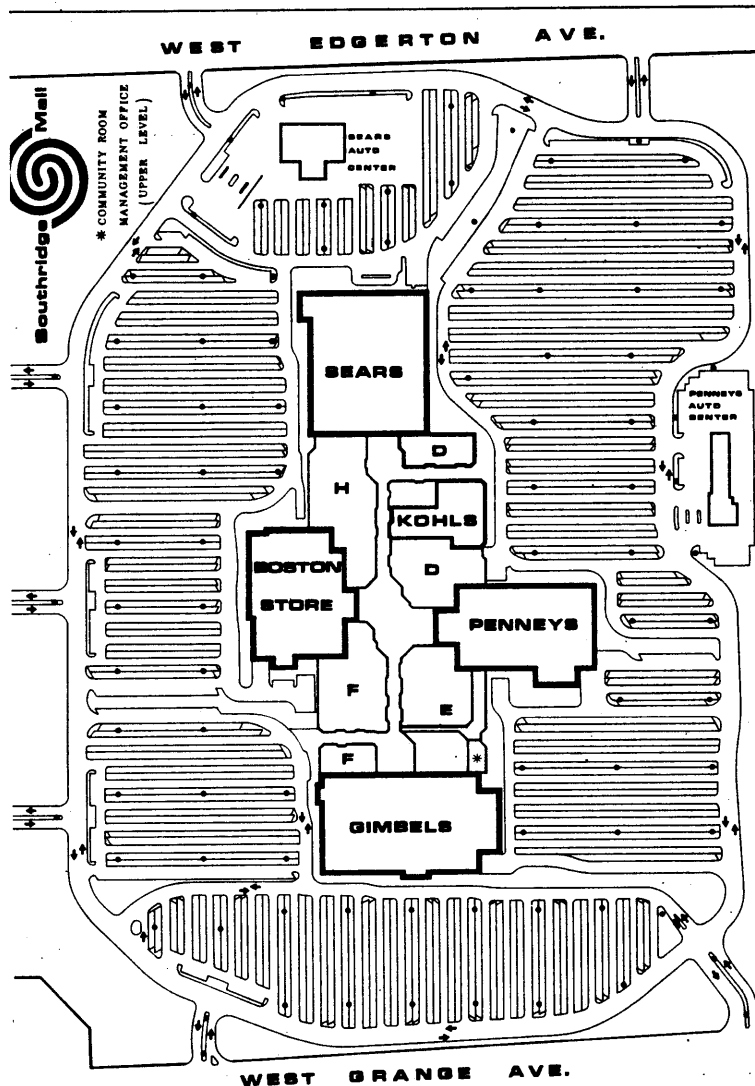

Parking lots are just that and nothing else. No amenities or landscape elements are provided which might make shoppers linger there. Seating, bathrooms, telephones, drinking fountains and vending machines are all within the complex, and no coverage or weather protection of any kind is allowed to foster inhabitation of the lot or the building's edge. Parking is organized in a uniform band around the center to minimize distances between cars and stores. Rows of parking are organized perpendicularly to the exterior walls of the building so that shoppers don't have to cut through rows of cars to get into the building. Parking lots, in summary, are designed to get shoppers into the building as soon as possible.

Once you are inside, the outside world is to be forgotten, all the action is inside. Windows are completely absent and natural daylighting is always from skylights. Entrances into the mall are always perpendicular to the main circulation so that one never views the outside axially from the main circulation. Instead, the outside world is abstractly re-created for the shopper in the circulation



SHOPPING CENTER CIRCULATION AS INTERIOR STREET (6)

zone. The metaphor for the design of this zone as coined by shopping center developers is "the street" or the "town square". Water fountains, formal plantings, clock towers and statues are the components that contribute to the shallow mimicry of the urban experience. The zone, however, is capped at each end by the department store anchors, a final gesture that prohibits growth of the center and continuity with anything else in the environment.

So, besides being dissociated from the street, the shopping center developed to recreate it, without rain, snow, garbage, bums, poor people, cars, dogs, dirt and three quarters of what streets are all about. In the 1970's, the single use shopping center developed from an indoor street to an indoor town. Developers recognized the benefits of providing bars, restaurants and cinemas because they extended the life of the center

beyond hours traditionally associated with shopping. They also provided "captive markets" for themselves by providing office space for professionals like doctors, lawyers and engineers. Suddenly the shopping center had usurped the functions of municipalities in their aggressive quest for finding new markets. They even developed their own police forces. Developers had finally realized that shopping is an activity that can successfully live off of the activity generated by other functions. Today one has the possibly unwanted opportunity of even going to church at a shopping center.

However, the replacement of a government administered town by a corporate administered town destroys the possibility of a community being able to participate in the democratic process of determining not only how a town should be run, but also what the physical place should be. The public realm is no longer owned by the people, but is set up for them. A generation of people raised on the non-participatory media of television and radio, and not face to face interactive communication, seemed to be ripe for this authoritarian approach to town

design.

27

By virtue of the discontinuity of exterior public space, the quasi public realm of the shopping center becomes a place where a private institution has the potential of limiting the constitutional rights of individuals, because technically, the shopping center is private property. Inhabitation of this so-called town square is, first of all, limited to the operating hours of the center. Secondly, the traditional street, with its intensified public inhabitation, became a forum for free speech, the right to express one's own opinions in written or spoken form. The street has always been the place of a diversity of ideological, political and religious viewpoints. But the depopulation of streets due to the discontinuity of the functionally zoned landscape has removed the public audience to a private territory. The question arises, can an individual walk into a shopping center and give a speech on the merits of socialism or the importance of the Equal Rights Amendment or does the shopping center management have the right to censor the activities of their so-called town square?

The problem exists for merchants also. Suddenly owning a store becomes a liability instead of an asset. Being within one container often implies operating on a timetable set by the management. Retail businesses are an opportunity for the average American to regiment his/her own life, but shopping center management often enforces a stay open policy, or a stay closed policy. Ideally, stores should be built such that flexibility of operation is a priority of the store operator.

A policy like this is one of the factors that forced many of the meat and vegetable concessions at the Faneuil Hall Marketplace to go out of business. Management required butcher shops, for example, ^{to} stay open past their traditional hours of operation, which were nine to five. The extra five hours of operation, five to ten in the evening, was required by the management to keep the place as alive and active and therefore inviting to the public as possible; but food shopping tended to be a daytime activity, engaged in by housewives only, not families or couples out on the town for an evening of entertainment. These extra five

28
hours of operation became a period of time in which the cost of operation grossly outweighed the profits from sales. Consequently, the marketplace has become more of an entertainment district for suburbanites and tourists than a place to buy necessities for urban dwellers in the area.

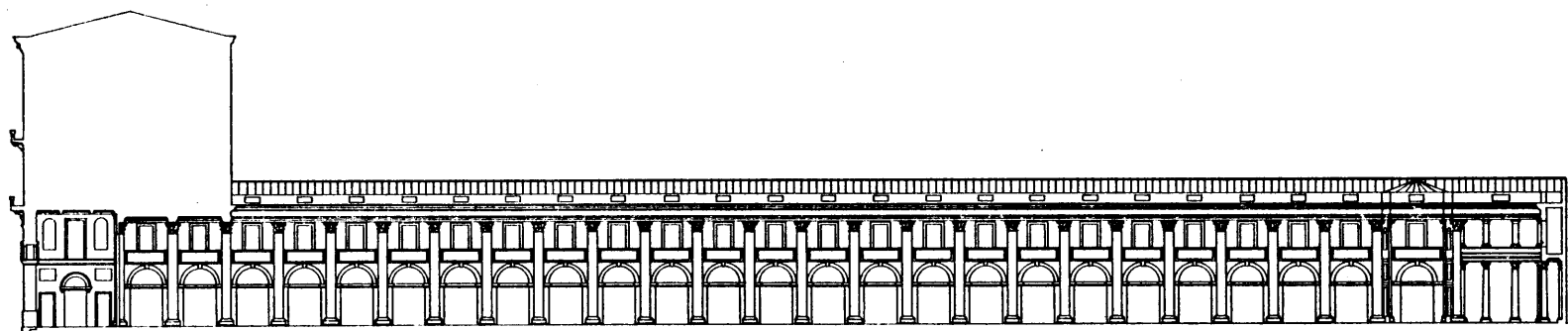

(7)

GALLERIAS

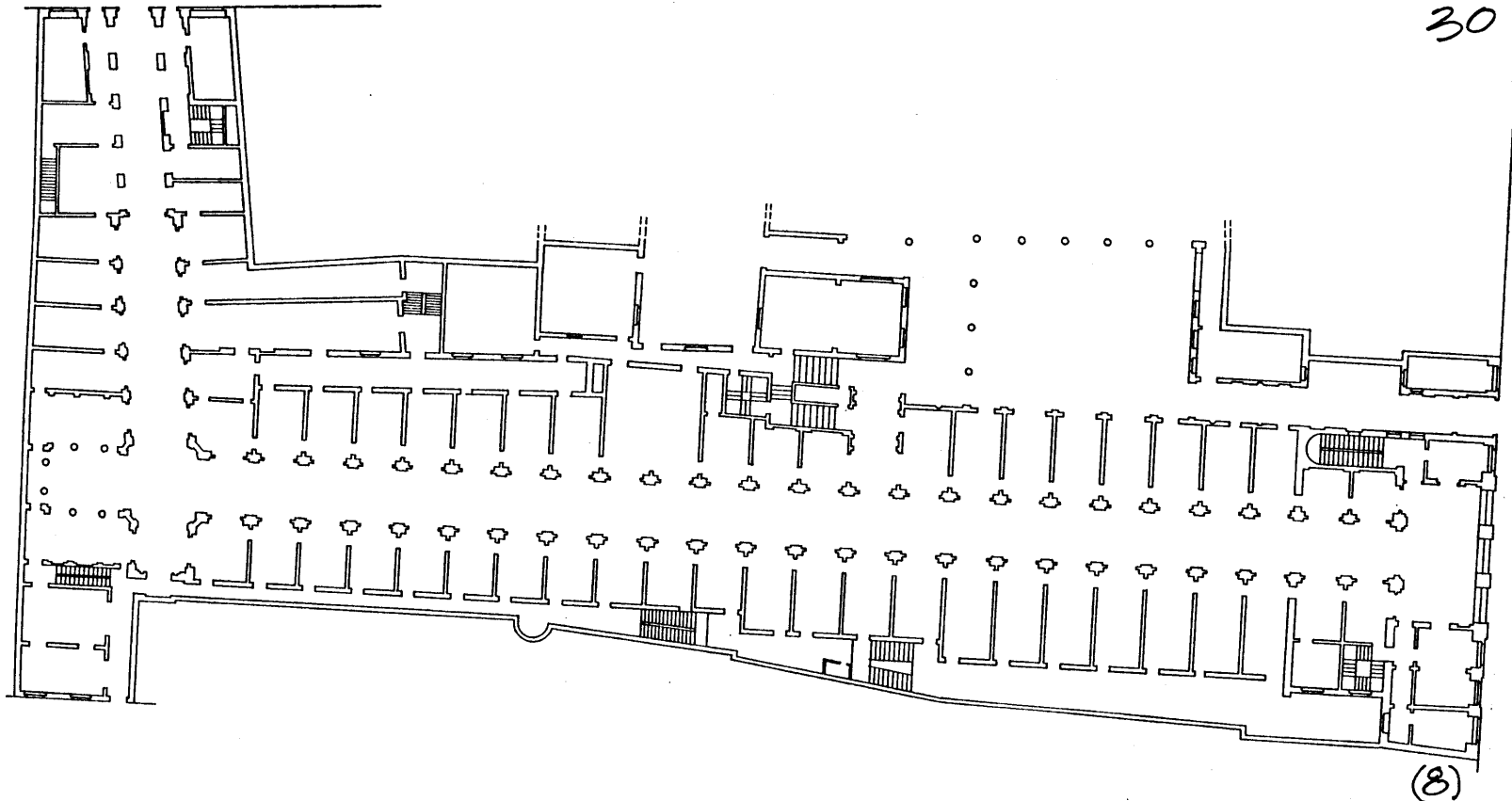

The attractiveness of the public environment as it relates to shopping activities has always been a problem for merchants. As long as the public environment remains sympathetic to the needs of people, retail markets can remain an integral part of the public environment, but when conflicts arise in the urban fabric and compromise the comfort of

pedestrians, marketeers become urbanists and create exclusive realms within cities.

The shopping center as a separate entity came into being as a common building type during the nineteenth century in the form of the galleria, an ancestral cousin of the regional shopping mall. Conditions of the open street were thought to be unbearable because of the

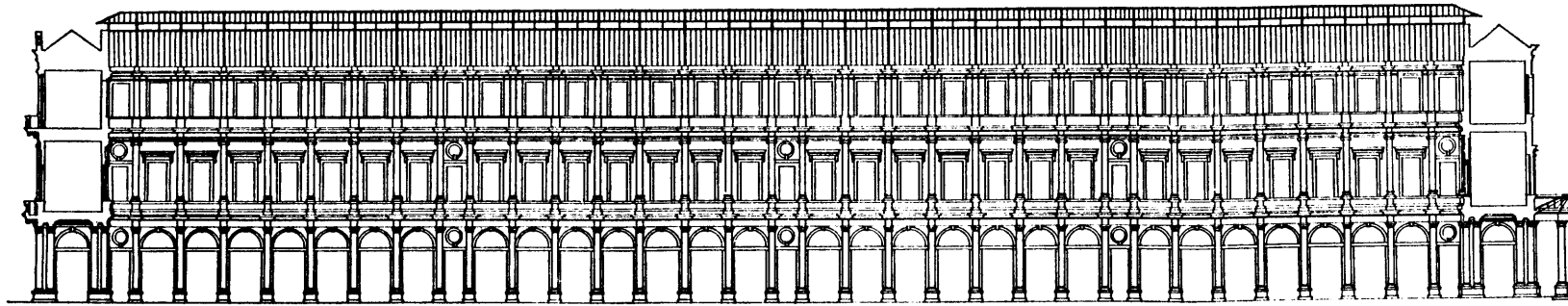

(9)

conflicts between pedestrian traffic and horse and wagon traffic, the profuseness of animal droppings, garbage and beggars, and sporadically inclement weather. Merchants were looking for an environment that was completely free of these unpleasanties where shoppers could concentrate on browsing and buying and not dodging traffic and droppings. The gallerias were consistently clean and dry no matter what conditions existed outside, and like the modern day shopping center, probably maintained a certain amount of selectivity of clientele.

Diagrammatically, the gallerias were usually double loaded corridors, an interior

street of small, identical shops on both sides, with a sectional organization of two stories of retail shops at the ground and two or more stories of offices or some other uses higher up. The open interior street was typically roofed with a glass canopy much like a greenhouse. The architecture of the interior street resembled the architecture of the exterior city streets, a point consistent with the fact that gallerias often were either extensions of existing streets or connections between major thoroughfares. Very infrequently were they dead end paths which became worlds unto themselves.



CLEVELAND ARCADE

(10)

The glass covering also allowed the retail street to develop into a multi-tiered organization; circulation at upper levels could now be free of the interior of the street facade and thus be visible to the main circulation at the ground. Shoppers are not only attracted by store displays but also by the movement of

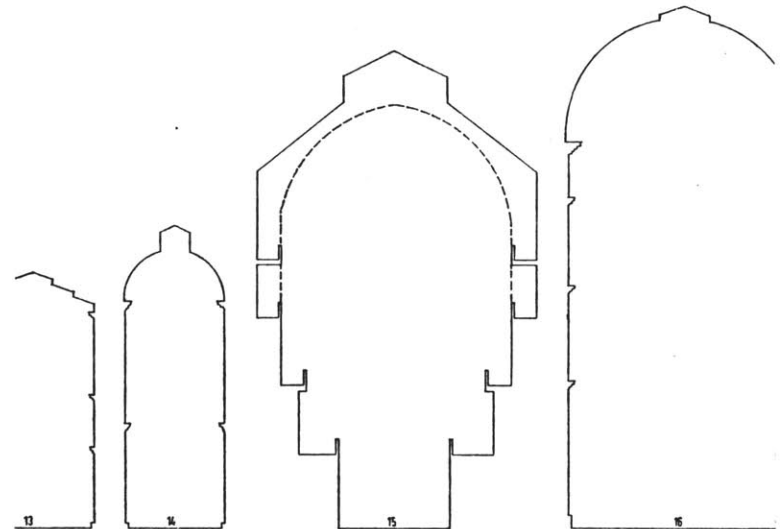

CLEVELAND ARCADE (15)

(11)

other pedestrians. To achieve this, designers began to pull a frame away from the skin of the facade as in the Cleveland arcade where the section within the galleria began to step so that each level of retail circulation had an open outdoor quality as opposed to being contained by the floor above.



GALLERIA VITTORIO EMMANUELE II (12)

Certainly, the most famous galleria of the nineteenth century is the Galleria Vittorio Emanuele II in Milan. From the site plan, one notices that this galleria, composed of two axes, one major and one minor, is really an intensified part of a larger network. The major axis becomes a link between the Piazza della Scala at the top of the plan, and the

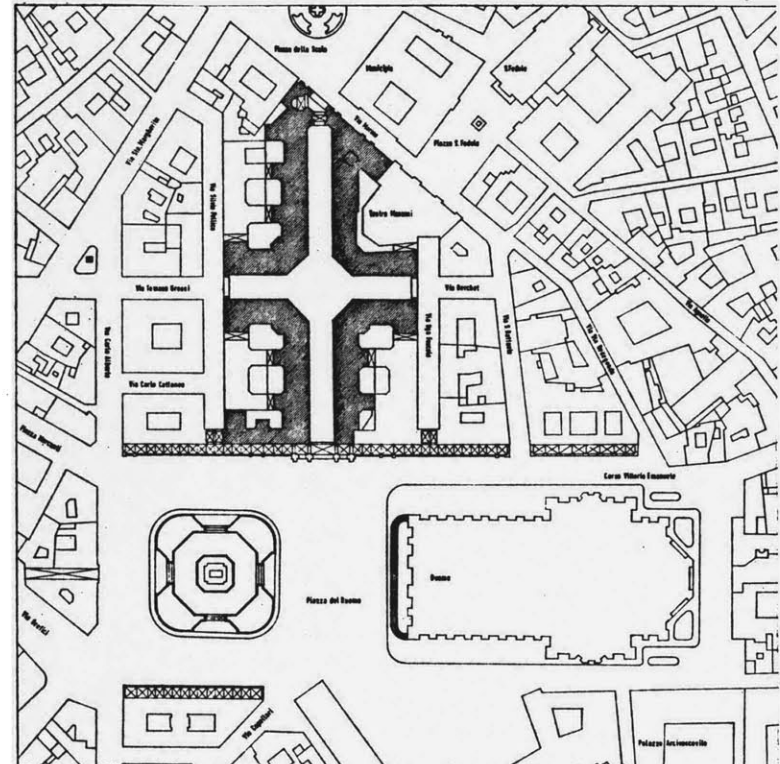

GALLERIA VITTORIO EMMANUELE II (13)

Piazza Duomo at the bottom of the plan. The minor axis is built as an extension of Via Tommaso Grossi and the Via Berchet. One can imagine that these extensions of the axes, beyond the glass covering, became almost as desirable for retail space as the galleria itself, because pedestrians had to travel through these extensions to get to the galleria.

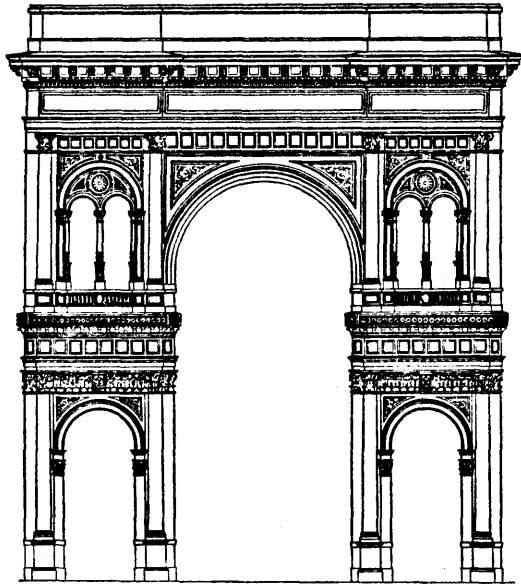

(14)
ENTRY: GALLERIA VITTORIO EMMANUEL

Entries into the gallerias were large ceremonial pieces reminiscent of triumphal arches and ancient temples, but they were not doors. The scale of the entry piece was large enough to mark the beginning without becoming a discontinuity. It was a piece that approximated the section of the street dimensionally.

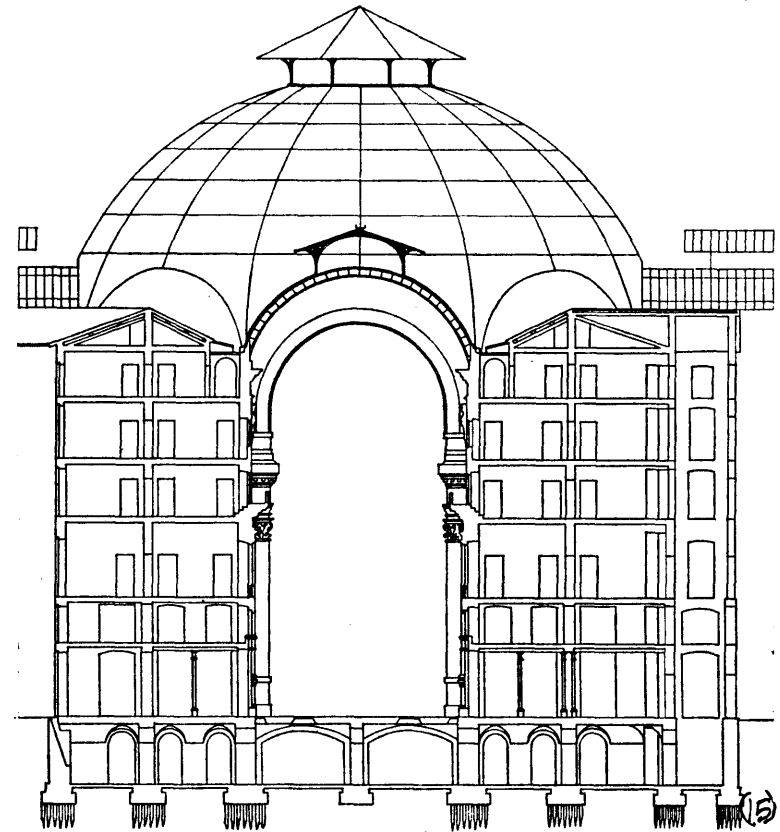

(15)
SECTION: GALLERIA VIT' EMMANUELE

If the galleria was an extension of a vehicular street, horse and wagon traffic was kept out by introducing a slight level change at the entry. Thermal closure happened at each individual store so that getting in and out of the galleria was as continuous an experience as walking down an exterior street.



GALLERIA COLONNA (ROME) (16)

Continuity was the key design factor which helped both the businesses inside the galleria and those outside. Some architectural element was always present to aid pedestrians in their awareness of adjacent territory. In the case of the galleria in Rome, it meant the establish-

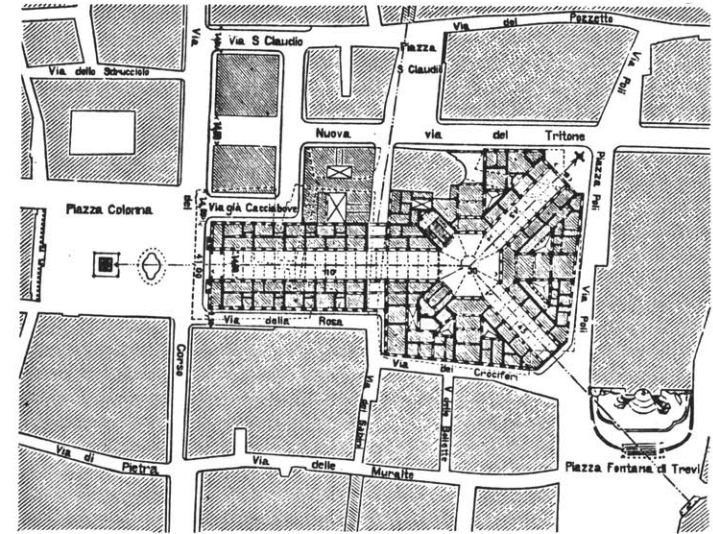

GALLERIA COLONNA (ROME) (17)

ment of circulation on axis with the monuments of adjacent squares, and the introduction of a non-directional space in the center to allow circulation to link an irregular network together.

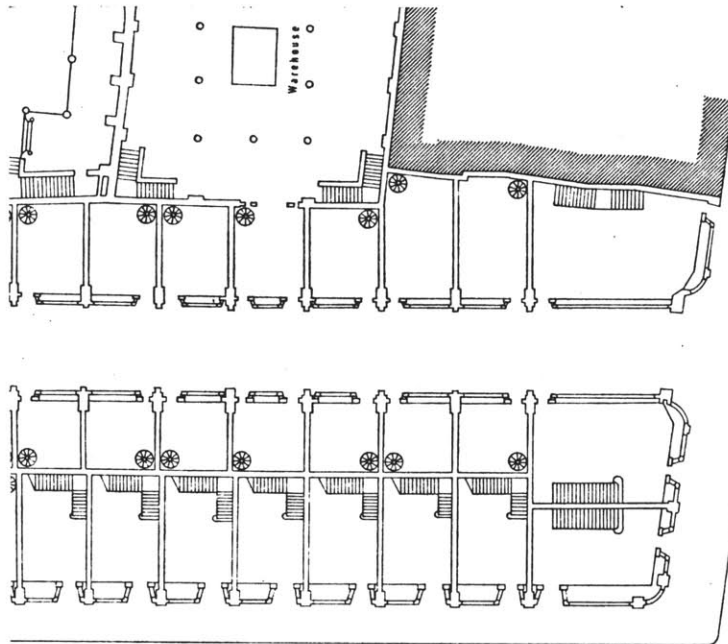

(18)

In English gallerias, which were often perpendicular to major streets, the establishment of continuity was always made by allowing window displays of shop fronts to turn the corner at the entry. Thus the end piece addressed both the street and the galleria space. The arcade consequently became a passage through a block rather than a separate building placed in a slot on the street. This is a substantially different



(19)

approach from that of the suburban shopping mall which never allows its main axis of circulation to get beyond the inside of the building. In the mall configuration, the department store anchors always act as an intricate baffle between the interior street and the outside, which strongly suggests the inappropriateness of the suburban type for urban contexts.



Bridge St. West

(20)

C H E S T E R

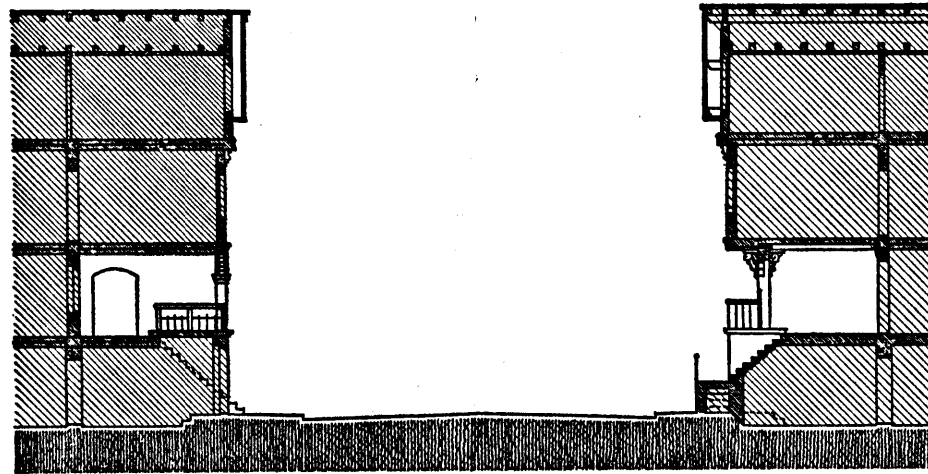

(21)

The city of Chester, England; a regional market center located at the edges of the English and Welsh countryside provides an interesting model for how a retail center can be integrated into an urban context. Like the gallerias of the nineteenth century, Chester's commercial architecture attempted to provide an environment for the pedestrian that was partially dissociated from the traffic of the street. However, in the case of Chester, the pedestrian system has a parallel relationship

to the street as opposed to being an extension of it as in the case of the gallerias.

The retail buildings are primarily organized along one main shopping street with a unique two level pedestrian circulation system consisting of a ground level and a second story level that is covered but open to the street. Access to the second story circulation occurs directly off the sidewalk via open stairs that generally run perpendicular to the direction of the walkways.

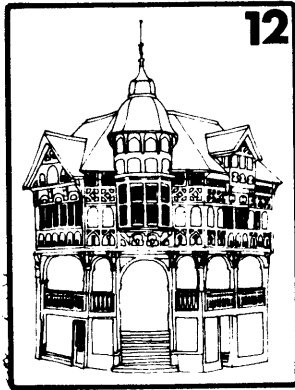

(22)

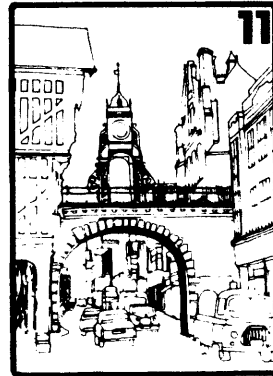

(23)



(24)

These stairways also exist where perpendicular streets intersect the main shopping thoroughfare, and then become oriented on a diagonal. Where blocks become long, stairways are introduced at an interval of about every three buildings, or a distance of 50 feet. Where minor perpendicular streets, such as residential ones, intersect with the shopping street, bridges maintain the continuity of the

second level. Bridges which tie the second story walkways of both sides of the street together occur at opposite ends of the main street, one of which forms an entry into the city. These bridges, in concert with the high frequency of stairways prevent the second story from becoming an isolated commercial trap. The apparent overbuilding of stairs also allows them to become useful territory beyond

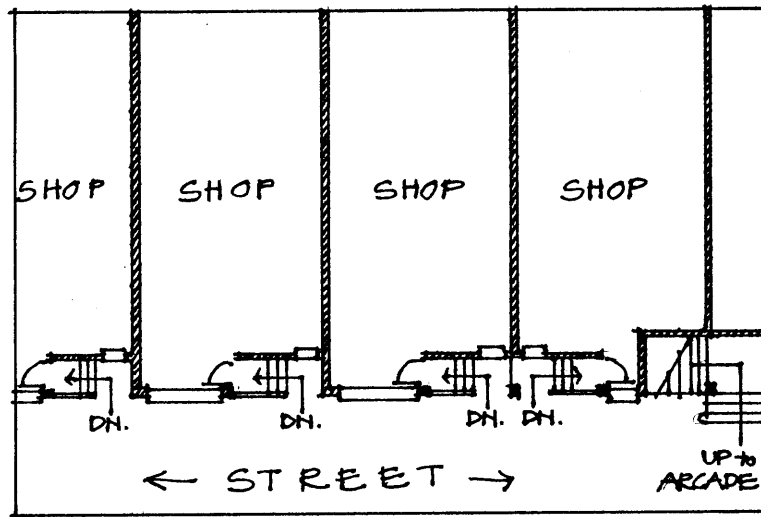

CHESTER: Plan at street level being just circulation. Besides providing protection for the elements, the second story walkway is organized so that circulation occurs as a zone in between the store entries and an outdoor zone defined by the columns that hold up the third floor above. This territory, which occurs rhythmically, is about 5 feet by 12 feet and provides an area where either market day vendors can operate or the larger store can operate beyond the limits of its thermal enclosure and create an overlap between public circulation and retail territory. Shopping researchers have found that half the problem

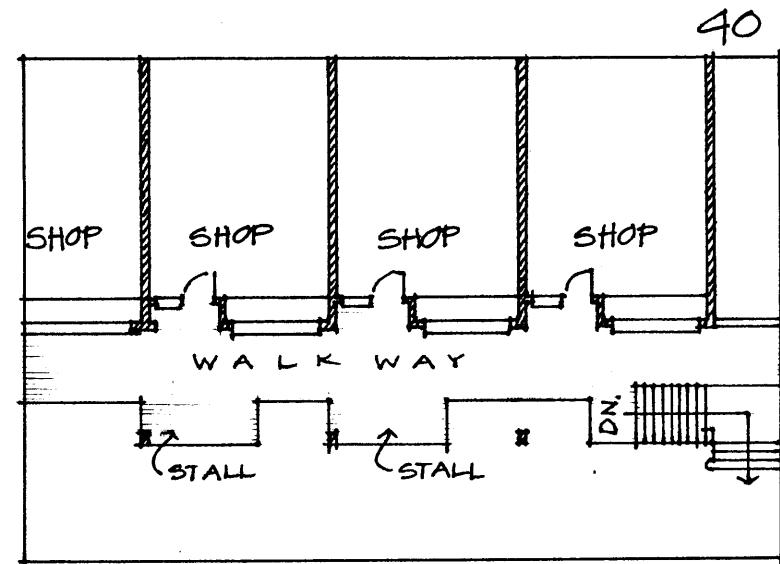

CHESTER: Plan at upper arcade level of selling retail merchandising is getting the customer into the store. By creating this overlap, the pedestrian is always moving through each store even without actually passing through the thermal enclosure. It is a process of gradually transforming the enclosure from street space to store interior. If much of the activity of the store's business can occur in the space of the street, the awareness of a pedestrian's return to the public realm upon leaving the store is diminished, and this continuity allows each store to remain part of the larger system, rather than competing with it.



(25)

On the first level, the arcade is much less continuous; some stores have built out to the column line forcing circulation to remain in the street and unprotected. This creates a balance of desirability for the two paths. On the second level the structure remains very framelike so that the association of the second level, back down to the street is never interrupted.

41



(26)

Above the second level, the strong collective order of the repetitive structural frame that is so apparent at the ground disappears behind Elizabethan, Georgian, Edwardian, Victorian and international style facades. Even the new buildings have respected the system. These highly individualized pieces on top give each segment of the street an identifiable character which makes the street an

additive series of zones, rather than an extrusion.

This system's positive qualities are based in its abilities to maintain the street as the place of both vehicular and pedestrian circulation and as the single place of economic and social activity. The efficient use of land afforded by the stacked circulation halves the amount of land that the commercial district covers making pedestrian circulation the preferred option, thus creating an active social environment. The system breaks down however, when the continuity of pedestrian circulation is broken, which occurs when a perpendicular street gets too wide to bridge across or when a building burns leaving a gap. In new applications of this type of system a fire-proof primary system, probably concrete, would have to be used to maintain continuity. Construction or remodeling of individual buildings could go on without affecting the walkway. In Chester buildings in the commercial zone are constructed to add up to become a larger system. Only zoning laws enforce the participation of all building owners in the system.



(27)

Alternatively it could be built as a very permanent support structure that could be added to but not destroyed. Without much effort, a city government could take on the responsibility of building the support system which is the public circulation, and then parcel out each zone to an entrepreneur with each store to be designed by a different architect which would guarantee the presence of an additive quality to the street.



B E R N

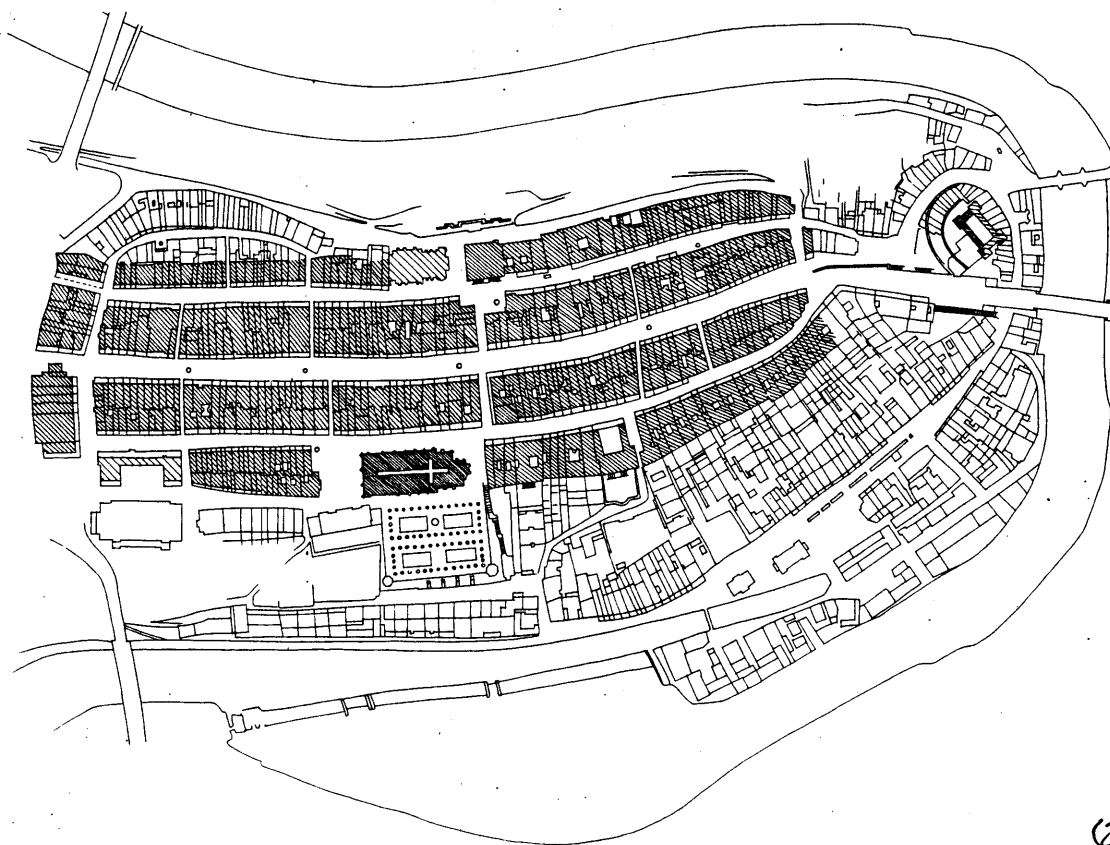

The small city of Bern, Switzerland provides yet another model for urban commercial architecture. Bern, along with eleven other Swiss and German towns, all of which still thrive as commercial and cultural centers today, was planned and built as a speculative settlement during the twelfth century by the ducal house

of Zähringer. The Zähringer family's expectations of the money making potential of the emerging class of merchants and craftsmen lead them to develop guidelines for the new towns which were based on the primacy of market facilities. The most important feature of the typical Zähringer town plan is the spinal

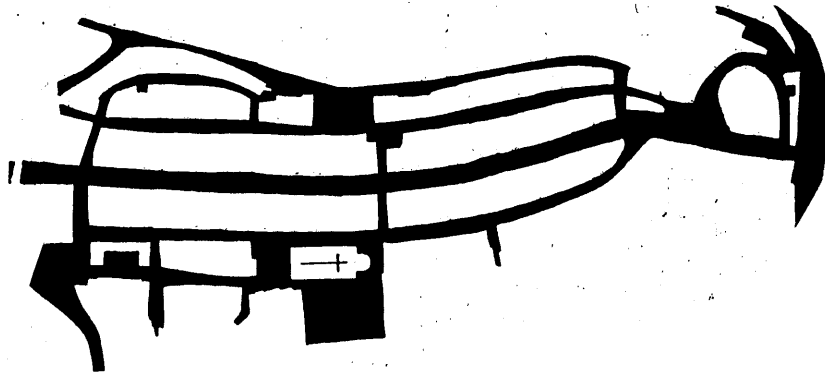

BERN

(30)

organization of the market and its colinear relationship to opposing points of access to the city defined by the directional quality of the land form, a rock ridge wedged in a loop of the river Aare. Governmental, religious and military structures were placed in locations subordinate to the spine. This gave the commercial buildings maximum exposure to the main circulation through the city. As a planning concept this was a substantial break from the centralized, militaristic planning of the Medieval era where placement of the market square was subordinate to military structures, thus limiting initial size, exposure and eventual growth or continuity with new centers.

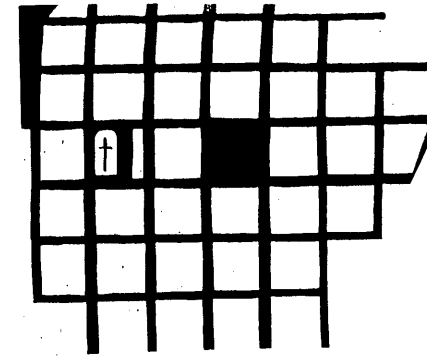

MIRANDE

(31)

Irvin Galantay, in his article, "Old New Towns", makes an interesting comparison between Berne and the city of Mirande, a French new town, referred to typologically as a "Bastide", also of Medieval origins.

In Mirande the market square of 180 feet by 180 feet amounts to only 3.2 percent of the 35 acre town area and the distance between town gate and market is 600 feet. Had the area of Mirande doubled, the percentage of the market total would have decreased to 1.6 percent while the distance from the gates to the square increased to 840 feet. By contrast, Zahringian Berne with 25 acres of built up area, provided three acres for the market, or eleven percent of the

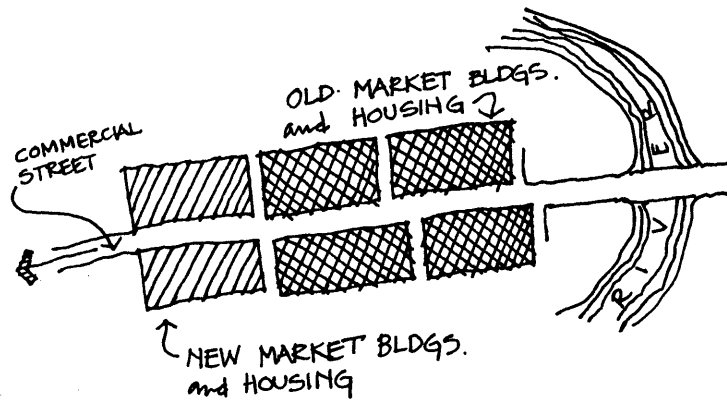

total area, and in future expansions the city was able to maintain this favorable ratio and access to the market remained direct through the gates. Mirande never grew, the self suffocating checkerboard of the "Bastide" is a closed system while the Zahringer plan is essentially open ended.

Unlike the closed system of the Bastide, or for that matter of the suburban shopping center, the spinal organization and growth pattern of Bern allowed each addition to the city's market structure to magnify and intensify rather than compete with the economic success of the existing

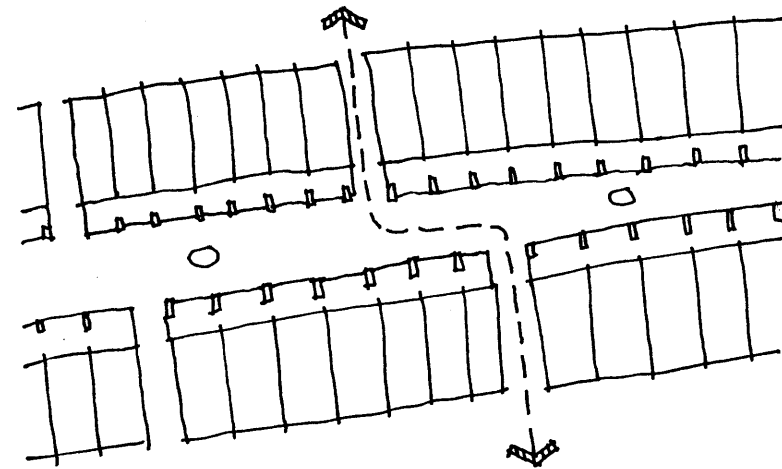

spine. It was a process of growth rather than parallel duplication. The intensification of activity provided by the growth of the town activated the old as much as the new, and the continuity of the linear form allowed the two to work as one system. One's perception of the extent of the commercial district could be unlimited as long as the spine remained the major organizer and remained continuous. One of the other important aspects of the Zahringer town plan was the very secondary nature of side streets, a quality that was enhanced by offsetting them at their intersection with the main spine forcing

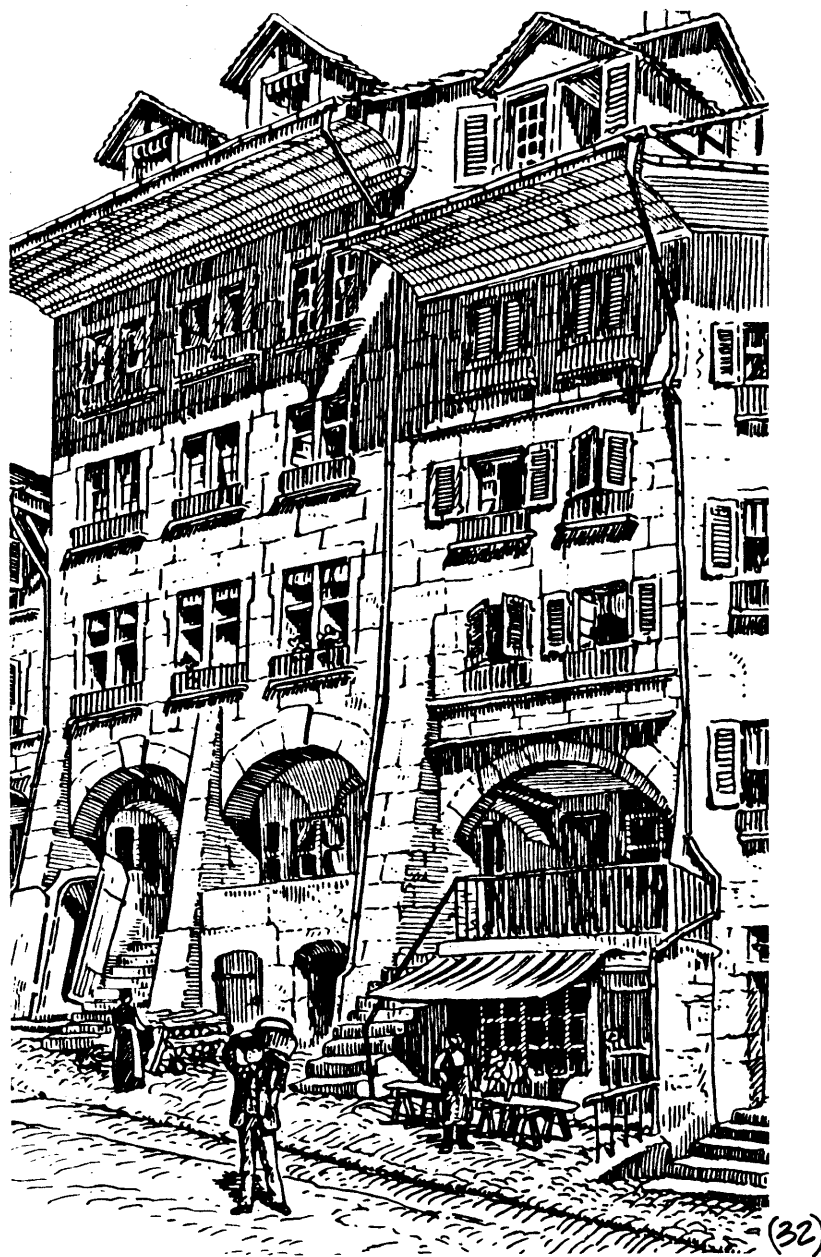

cross movement to associate with the main spine which further intensified it. New growth always referred back to the spine in the same architectural manner that the old stuff had. The choice of which marketplace to go to never arose as an either/or question.

Commercial continuity along the spine was complemented by the simultaneous continuity of housing, service access, vehicular traffic, and an open water supply system that remained until the end of the nineteenth century in the center of the market street. The businesses of Berne flourished given this concentration of activity. To this day the medieval city remains as the undisputed commercial nucleus of the region even though Bern has experienced the non-directional urban sprawl typical of modern cities. This fact should not be taken lightly since many Medieval towns either died hundreds of years ago or have been replaced as nuclei by competing contemporary urban centers.

Bern's lasting commercial success is also attributable to its architecture and not just its planning. Like Chester, Bern's market street offers the pedestrian an arcade, open to the



street, for protection from the weather. Above the arcade and the upper three levels of housing, a fourth attic level with a five to six foot cantilevered eave offers additional protection to activities occurring at the edge of the street.

Unlike Chester, it is only the upper level of Bern's arcade system that is used exclusively

for stores. The lower level which emerges from the ground as the upper level remains horizontal and the street slopes down to the edge of the river was developed for service entries for the shops above. This integration of served and service space serves to activate the street without letting the two interfere with each other.

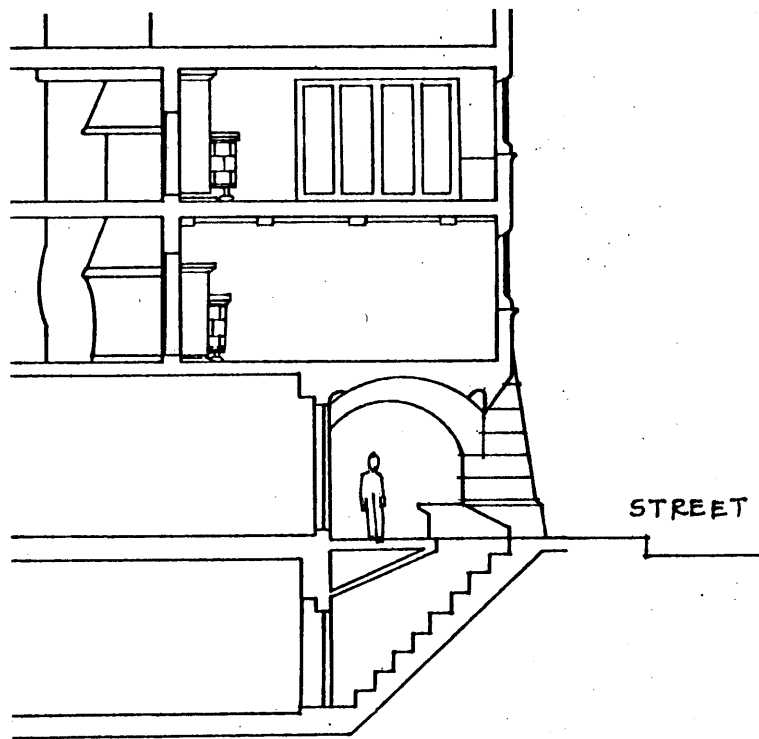

(34)

The structure that forms the arcade widens from the top of the arcade to the bottom to become piers running perpendicular to the facade. This zone creates an overlap between the store and the circulation and provides territory for the stores, for transient merchants on market days, and for outdoor eating areas associated with bars and restaurants along the arcade.

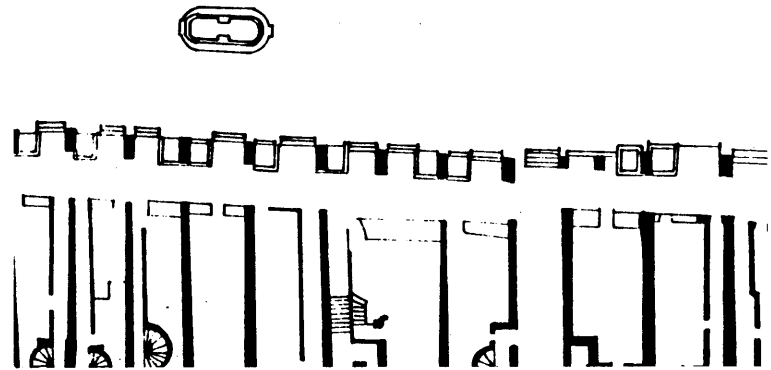
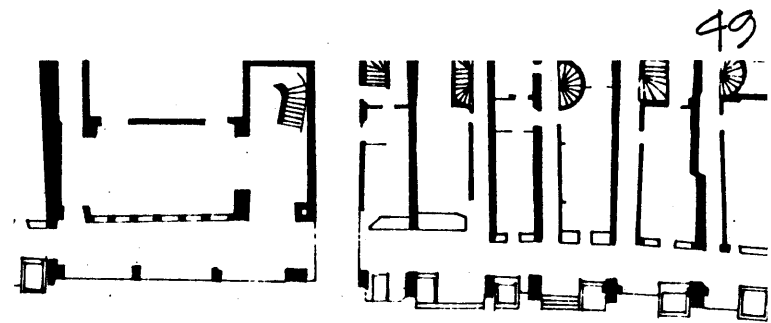

(35)

All of this, along with the high frequency of stairs running down from the pedestrian level and into the street foster a high degree of street use. When the facade of a street becomes as habitable as this the activity of buildings and circulation of the street is interfaced allowing the kind of creative interaction that businesses require to survive.

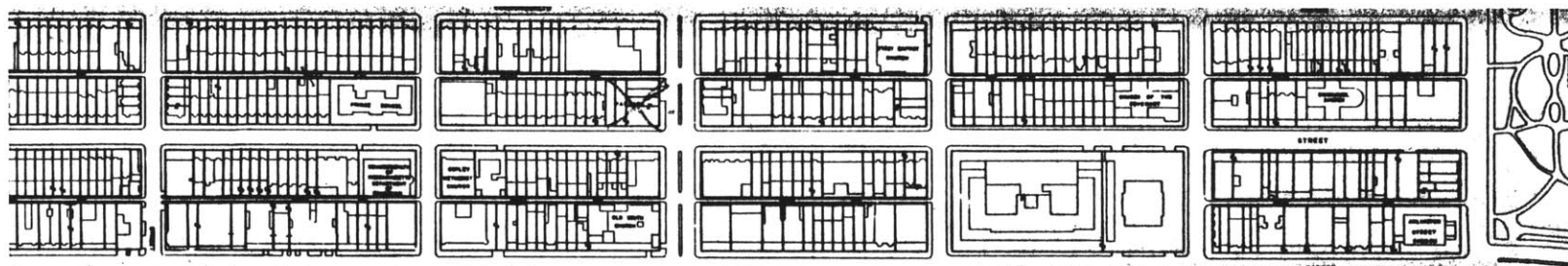

(31)

NEWBURY STREET



NEWBURY STREET SIDEWALK

At a certain point, it seemed important to examine in detail the way in which commercial architecture had been designed in an American urban context prior to the functionally zoned planning of the twentieth century. I chose Newbury Street in Boston, Massachusetts as a model to study, and I discovered that although it was generally regarded as a retail environment by outsiders, it was really much more than that. It is a clearly defined public urban room



ENTRY TO BASEMENT LEVEL SHOP

in which all the activities of urban life come together to form a complete experience. Most important, though, was the presence of people in the street which seemed to be an attraction for many others. Based on the assumption that face to face interaction is a positive environmental quality, I asked the question: how does Newbury Street support human habitation of the public realm as opposed to only habitation of the private realm? The key to this seemed to be in inter-

facing many disparate activities within the street space, and retail facilities were the essential ingredient in this process.

The first generator of human habitation was the automobile circulation that had remained part of the street. In addition, parking is permitted on both sides of the street as opposed to being in separate garages or lots, so that the stationary activities of loading and unloading were interfaced with the pedestrian circulation. These parked cars presented a kind of obstacle to passing automobiles that forced them to drive a bit slower so that the potential for interaction between pedestrians and drivers was increased. This kind of interaction was found to be extremely common on Boston's Hanover Street, which is to the North End as Newbury Street is to the Back Bay.

The sidewalk was given a dimension that allowed more than circulation to occur. Telephones, newspaper vending machines and mailboxes were the next level of activity generators in addition to the fact that circulation from one store to the next was always a matter of going back into the street and once again having



to interface with the non-shopping activities of the street.

To a large extent, the business of restaurants and retail shops is carried on in the sidewalk zone as much as inside the buildings because of the definition made around each store entry by the introduction of a sectional organization that allowed stores to exist on two levels, a fact that intensifies the overlap of shopper



MERCHANDISE DISPLAYED IN THE STREET

circulation with other stuff by virtue of its double density. For the lower level, partially underground, the entryway became a place where much of the store's products could be displayed outside, or else where lower levels were occupied by restaurants, eating and drinking could occur, outside in the street. Even in bad weather there was a pattern of displaying a menu in a glass case in the zone of the sidewalk. The steps up to the upper level stores were

53



GLASS DISPLAY CASE IN SIDEWALK ZONE

generous enough to allow merchandise to be displayed on them and thus in the street space. Store window displays are supplemented by glass box display cases that occur as objects in the sidewalk zone so that browsing is a street activity as much as it is an activity of the inside of the shop. This is substantially different from department stores where all of the activity of shopping and browsing occurs inside rendering the street inactive.



BOW FRONT HOUSES

Another important element of Newbury Street was the presence of housing directly above all the stores, as a continuous element. Virtually all of the access to the housing occurs directly off of the street rather than through the rear of the buildings, and often it occurs via the same steps that are used to get into an upper

level store. This increases the possibility of merchant/housing tenant and shopper/housing tenant interaction within the space of the street. The housing itself, at the third, fourth, and fifth levels was developed to focus back down to the street. By relegating the private functions of bedrooms and bathrooms to the back of the house and pushing the more heavily used public functions to the front of the house, the potential for interaction between housing tenants and the activities of the street remained. This is especially the case in buildings where the Bowfront living rooms of adjacent apartments occur close enough to each other to generate outdoor territory in the form of balconies which emphasize the relationship of residential social activities to the street. This is substantially different from residential streets of suburbs in which houses still make references to the street but only in a formal manner. The chances of spontaneous interaction are slim because the bulk of the public space and its associated outdoor territory are actually in the back of the house separated from the street by the plane of the front lawn and the uninhabited plane of the front facade.



Service for both stores and offices was an activity that also took place on the street since the front door of the shop was the only way of gaining access.

Beyond this I also noticed that the retail stuff was not exclusively boutiques, art galleries and antique shops, but included a lot of the necessities of a residential community, including grocery stores and laundromats which prevented

residents from having to rely on mechanical transport to obtain these services. When shopping becomes merely an entertainment function, it becomes another functionally zoned entity, whether it occurs in the city or in the suburbs, and then forces the old fabric of the city to be destroyed and replaced by parking lots and expressways which create the discontinuity and subsequent fragmentation of the landscape. The city as it developed historically was a somewhat autonomous organism, a combination of many functions occurring at a sufficient level of density and simultaneity to allow economic development to occur along with social interaction. Spatial organization was the network that tied the city together rather than the technology of mechanized transport and electronic communication. If the spatial quality of the city and its potential for generating social interaction are important to us, we must learn to integrate functions rather than to separate them in space and time.

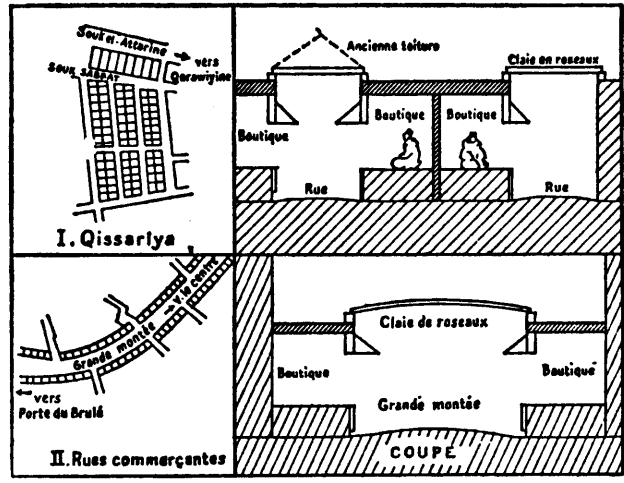

(37)

O P E N M A R K E T S

One of the major problems with the Pyramid Corporation's shopping center proposal was their stipulation that only stores with a sufficiently good credit rating would be able to rent retail space in the new mall. As far as Pyramid was concerned, nationally franchised or chain stores such as Stride Rite shoes or Crate and Barrel Housewares were the only businesses besides major department stores that fit into this credit rating category. Even local merchants who would be displaced by construction of the new center were not on Pyramid's acceptable list. The physical form of the Pyramid proposal also supported the limitations created by the credit policy. Not all businesses are large enough or wealthy enough to afford the conveniences of a climate controlled modern store interior with a minimum of 2000 SF of display space not to mention storage and delivery facilities. Pyramid was simply not serving the needs of the local business community, as it existed, or as it could exist by placing barriers against involvement in the actual business of the center. Somehow, a shopping center ought to provide opportunities for not only the large and well es-

57
established merchants, but also for the small and/or unestablished merchant.

The answer to the problem seemed to lie in the architecture of the primitive marketplace. Examples of these institutions can be found most commonly in third world countries and to a lesser extent in this country. Traditionally markets were open air gatherings of hundreds of traders selling the necessities of life. Physical definition was, and still is limited to enough shelter to keep out the rain or provide a bit of shade. Building materials consisted of whatever the merchant could supply for himself and could dismantle and carry away at the end of the day. Often, as in the case of the Morroccan Souks, this was not more than a tent, or possibly a bit of wall definition forming a stall of no more than 25 SF.



HAYMARKET, BOSTON

Today, at Boston's haymarket, a fruit and vegetable market, this is still the case. Plastic milk cartons filled with concrete anchor used 2 x 4's, lead pipes or even rake handles to provide the vertical support for roofs of once discarded plywood, sheet metal and plastic tarps, making the most temporary of structures. The investment in a business is limited to the time



HAYMARKET, BOSTON

spent in scrounging for the building materials and finally erecting them. Powerful advertising is gotten from operatic voices, and cigar boxes substitute for cash registers. According to James Rouse, the developer of the Quincy Markets, "The Haymarket is the last bastion of free enterprise capitalism. Anyone that can get a peddler's license and has the gall can play the game, as long as he can shove his way in."

In some cases, where markets have been truly institutionalized by municipal governments as at Les Halles in Paris, large collective shelters were built, especially during the nineteenth century and spaces were leased by a governing market organization. The investments remained minimal. Also in Boston, at the Faneuil Hall Marketplace, there is a central market building with two five hundred foot long glass canopies which shelter the "Bull Market", a collection of wagon wheeled push carts rented out to small businesses that are often run by craftsmen such as jewelry-makers, artists, leather workers, weavers or just first time entrepreneurs with a unique product. These Bull Market vendors have one month leases with the market management which makes a business venture even easier to get into and out of. In fact this happens regularly. Some people sell seasonal or holiday oriented products and stay for only a couple of months. This constant change of enterprises adds to the vitality of the place.

The other important physical characteristics of these markets is the symbiotic relationship between the carts and some other form of retail

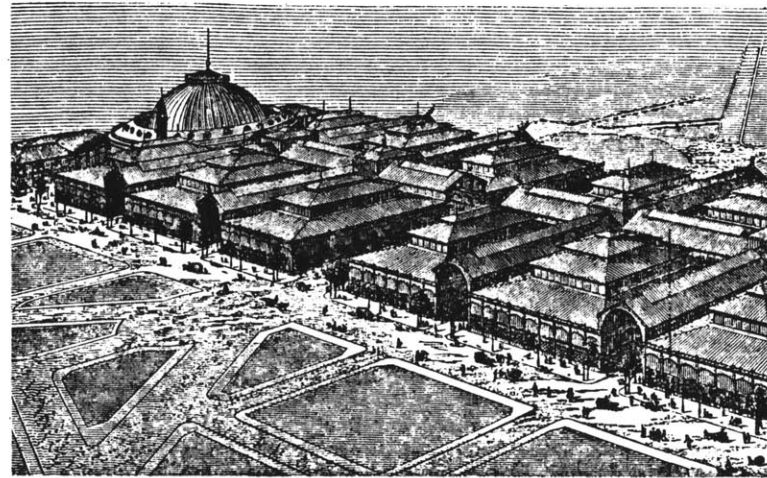

LES HALLES , PARIS

(38)

business. A fruit and vegetable man from Haymarket says it very directly:

That's another thing, we need the meat people as they need us. We have to work together, no question. During the week, the meat people really starve, they have no business. Friday and Saturday when we're here, this is when they make their money too. We've had offers from the city to go other places in Boston, but if we did, we'd kill ourselves because once we split up it's . . . it's . . . you've defeated the purpose.

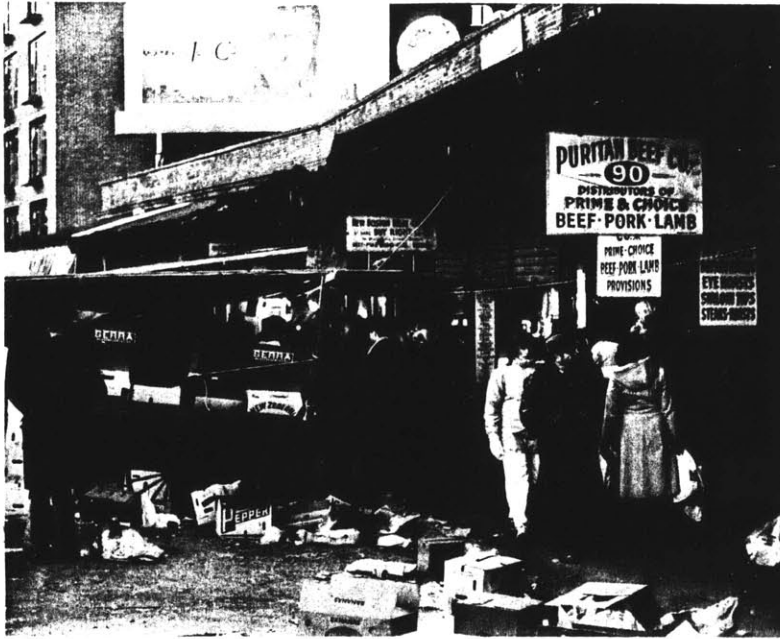

HAYMARKET, BOSTON

Haymarket carts are basically organized to form a kind of shopping street, a circulation zone with the vegetable carts on one side and the meat markets inside the buildings on the other. The activity of one generates business for the other, and the presence of the carts in the street produces inhabitation of the public

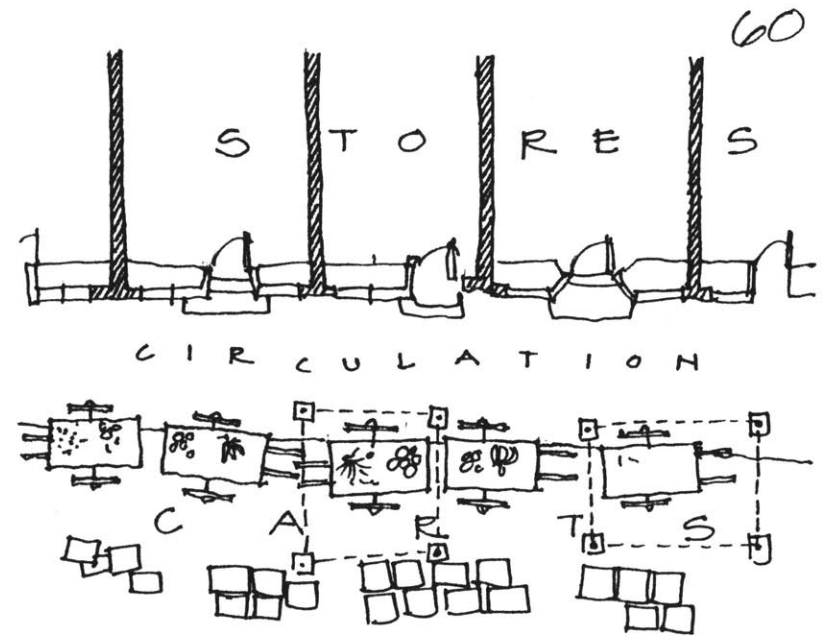

realm, an interfacing of the markets with non-related circulation of both cars and pedestrians, producing the potential for social interaction because of the activity generated as a focus of interest in public space. They also provide the beginnings of weather protection for shop entries.



GLASS CANOPY , QUINCY MARKET

The Bull Market carts provide a similar organization for Faneuil Hall Marketplace. They are enclosed in a light glass structure which allows the activity of the market to serve as a focus of interest for the spaces in between buildings, rather than only inside of them. Activation of the public realm allows walking from



BULL MARKET , QUINCY MARKET

one part of the city to another, or one retail zone to another to become an experience as rich as the interior of the market buildings themselves. Other retail businesses, located near the marketplace can then share, or live off the activity generated in the public realm.

Contrary to what most people believe, the public markets, like Haymarket, serve an economic, and not just a romantic or nostalgic need. Haymarket can offer a wide variety of produce at prices less than what supermarkets charge. Stuart Plattner, an anthropologist from the University of Missouri, explains in his article, "Public Markets: Functional Anachronisms or Functional Necessities?" how this occurs based on an analysis of the Soulard Markets, a public produce market in St. Louis.

When a shipment of produce arrives it is inspected before it is unloaded. If the produce is below grade it can be rejected by the consignee, who often arranges for a USDA official inspection to verify the condition of the produce. Produce does not have to be rotten to be rejected. Trimming is kept to a minimum because of the high cost of labor in the retail stores (for example, in St. Louis a major chain paid produce clerks with two years of experience \$7.65 an hour in 1978). The head of the produce division of a local chain remarked, "a man who earns cents per minute cannot really trim lettuce at an economical rate, if the produce needs more than minor trimming." Thus it may not pay the store to trim a case of

62
24 heads of lettuce in which 4 heads are totally rotten while the rest need minor to medium trimming. When a shipment of such produce is rejected, the shipper will normally try to sell it for whatever he can get at Produce Row. At that point the shipper's costs are spent, the produce is not getting any better, and any money realized on the shipment is better than nothing.

It is here that the economic benefit of markets such as Soulard enters. The Soulard merchant firms, using family labor, can afford to trim and rework produce where the chain stores cannot. Once trimmed the produce can be displayed in separate piles, each consisting of a different size or grade. Thus it is common at Soulard Market to see two or three prices for the same produce at one firm. This does not mean that market firms are selling inferior produce. Rather they are precisely matching price and value in a way that supermarkets cannot afford to do. For example, it makes no economic (or other) sense for a person who lives alone and rarely eats salad to buy a large head of lettuce. In a supermarket that is usually the only choice. A public produce market can offer a range of choices, within the restricted domain of fresh

produce. Of course, supermarkets compensate for their relatively restricted choices of fresh produce by offering many alternatives in other shopping needs.

If no strikes, refrigeration failures, dispatcher's errors or driver's mistakes ever occurred, then the supermarkets could offer fresh produce with high efficiency. Even in this ideal circumstance consumers would sacrifice variety and quality. Supermarket methods stress large volume and uniform products. Produce is inherently variable, and quality is often sacrificed for uniformity (e.g. Whitehill, 1977). On the other hand the owner-operated firms in public markets represent a pool of relatively skilled (compared with produce clerks) inexpensive labor. These small firms can handle variable and exotic produce. Thus the variety at a public market can always be greater than at a supermarket.

When the system breaks down and a load of produce is rejected by the supermarket then it is "kicked off into the street," or sold through jobbing firms. The more outlets such as public markets exist for variable produce, the less probability that food will be junked because it is not economic to trim it. Thus the public market serves as a "shock

63
absorber" for the modern produce distribution system, cushioning the effect of breakdowns in the system by allowing variable grade produce to be sold at reduced prices to consumers instead of being thrown away .

In Pittsfield one can imagine more than just produce markets operating in the street zone. Partially built or transparent structures might provide the opportunity for a woodsman to sell firewood or Christmas trees, or provide a market for hunters to sell animal skins, artists to sell paintings, or housewives to sell hand-made quilts or home canned jams and jellies, or the territory for junk collectors to set up flea markets. All of this would most importantly provide the continuity between new commercial intervention and the old existing retail zone and provide a partially weather protected zone along the sidewalk, especially in winter, for circulation from one store to the next.

CONTRIBUTY
LITERARY

(62)



4

As was demonstrated in the chapter on the development of the shopping center, most regional malls are designed to be discontinuous with their context, and most of this discontinuity is achieved by placing the building in the middle of a parking lot. The Pyramid Company's designers perceived the design problem in Pittsfield to be no different from ones in which there was a suburban context, that of an empty lot fronting on a major artery with no adjacent buildings to relate to.

My perception of the problem was that the design task included not only designing some new commercial space but also making some design gestures of physical continuities, at a pedestrian scale, between what was new and what was old or existing. It seemed important to set up a pedestrian network of which both the old and the new were a part, so that the commercial activity of the new building would complement and not replace the commercial activity of the old buildings.

Ideally, there would have been a number of separate sites along North Street on which a series of projects would be developed along

65
with a restoration program to upgrade existing buildings. In this case, the interest and curiosity of shoppers in the new would be spread around a bit. The older stores would get exposure to shoppers by virtue of being zones that were in between the pizzazz. But unfortunately, one big site existed and its relationship to most of the available parking space was a direct one. The other alternative, which was not entirely impossible, would be to decentralize the parking so that some of it could be associated with some of the older stores further up North Street. The goal seemed to be to get shoppers to at least walk by the old stores, in essence to maximize their exposure.

The first step in this process was to get shoppers up and into the space of North Street before actually entering the new stores so that the first experience became an awareness of the extent of the commercial zone. My observations, of Berne and Chester suggested a second step of introducing some sort of repetitive linear element that tied the new to the old in a very clear manner, an element that could be deployed all the

66

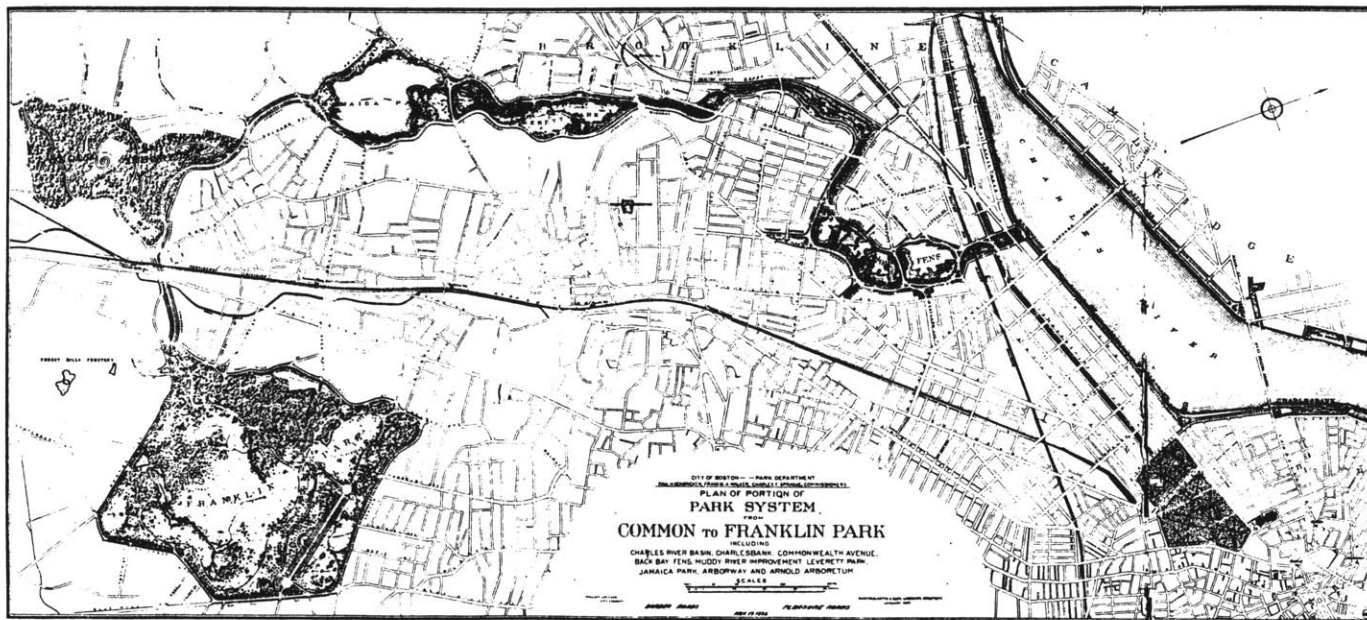

BOSTON PARK SYSTEM (F.L. OLMSTED)

(40)

way along North Street from one end of the commercial zone to the other. In Bern, this element had been the arched walkway, in Chester it was the second story framework tied to the surrounding city walls. I saw it as a principle used in a lot of places to establish a larger territory

within which related and unrelated elements could exist. On a very large scale it seemed to be operating in the city of Boston in the form of Olmsted's extensions to the commons, a linear green belt that linked the old part of Boston to its newer parts, Back Bay and beyond.

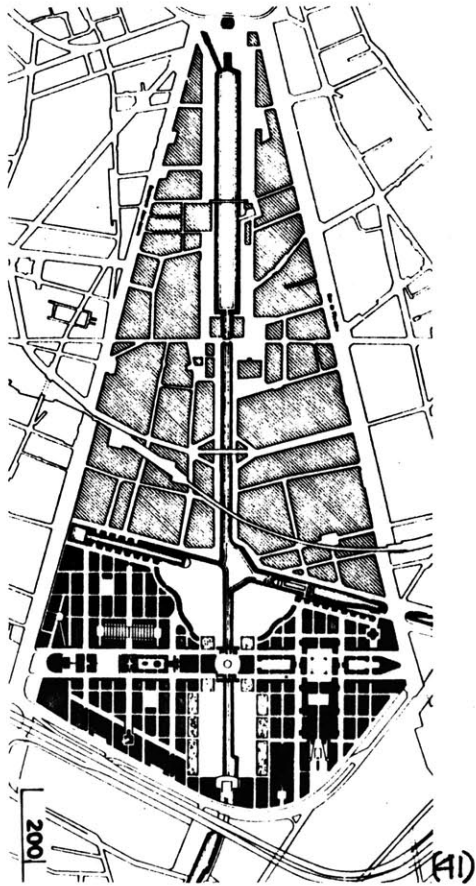

QUARTIER LINKED TO CITY (41)

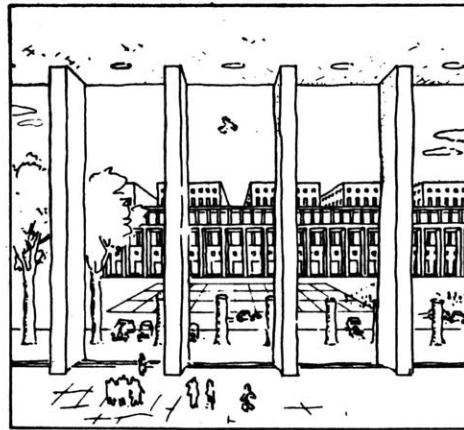

VIEW ACROSS BLVD. FROM (42)
WITHIN THE STOA



VIEW WITHIN STOA (43)

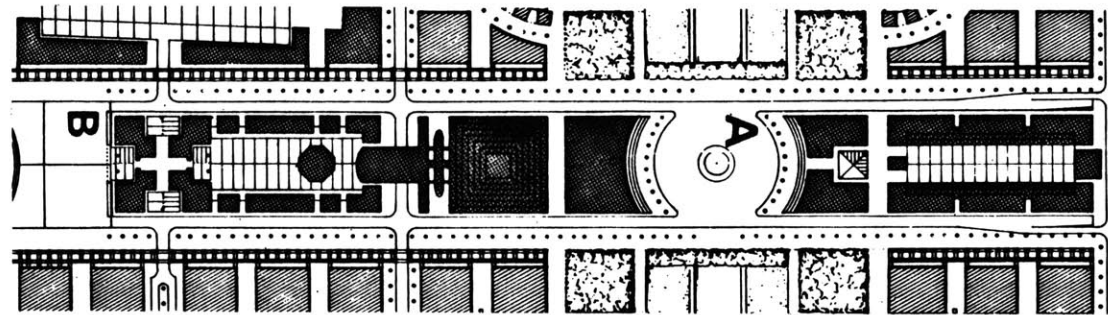

PLAN OF GRAND BLVD. (note repetition of trees and piers) (44)

It was also present in Leon Krier's project for the Quartier de la Villette in Paris. A green belt was used in combination with the Canal de L'ourc to link the quartier de la Villette, an economically autonomous region as designed by

Krier, to the rest of the city. Within the quartier itself, Krier introduced the Grand Boulevard, a giant axial container articulated at the edges by a highly repetitive "commercial stoa" and filled up in the middle with all the

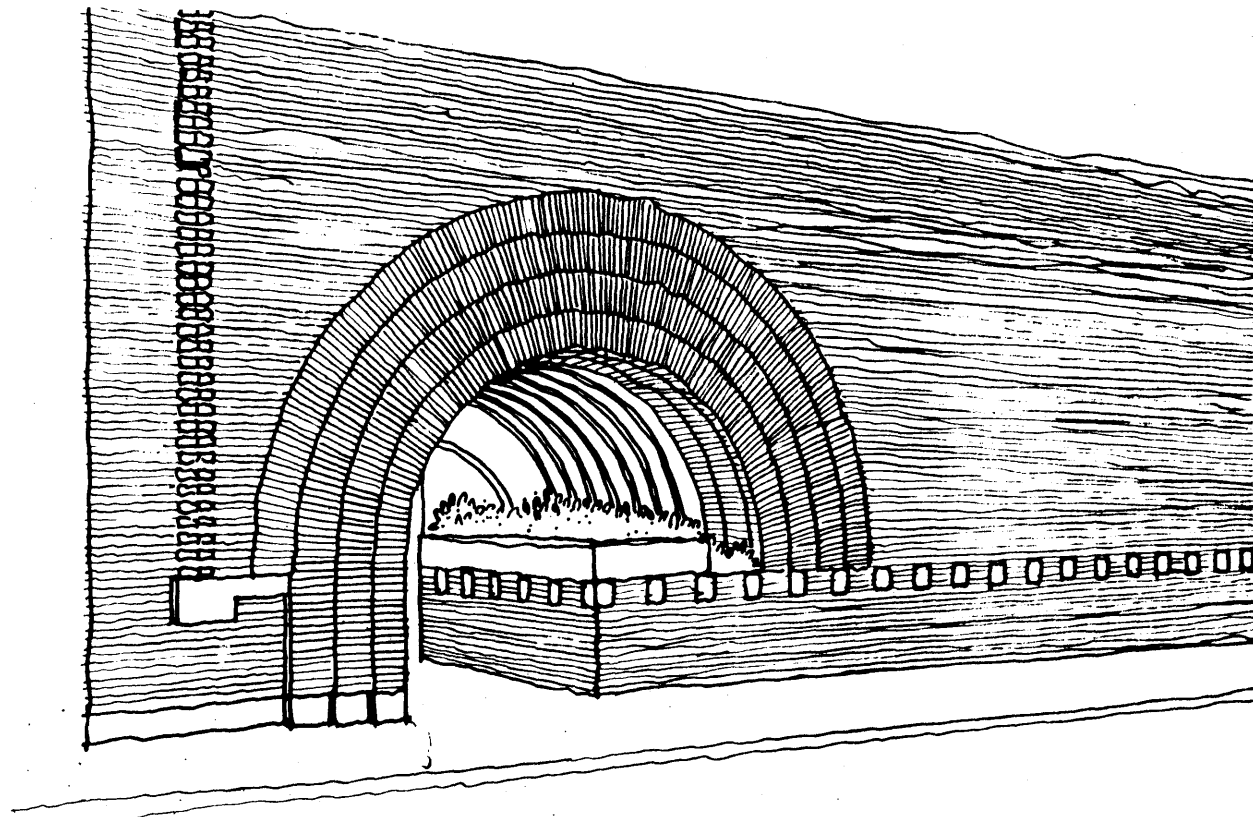

ENTRY TO V.C. MORRIS STORE IN S.F. (F.L. WRIGHT)

large scale cultural buildings of the quartier such as public baths, museums and libraries. At a smaller scale I also saw it operating in much of Wright's work, especially in the Usonian houses where very prominent retaining walls

were used to link the interior of the house to its outdoor spaces; or even in Wright's store in San Francisco where a line of light fixtures was used to direct circulation into the building.

In the new building, a spatial pier with a square footprint was developed to be the element that established public circulation and was repeated, sometimes in a very transformed manner, all the way down the street to the end of the commercial zone. This element would provide a framework for market stalls, transient merchants, street entertainers, and the street furniture that would be necessary if North Street were to become a real urban living room. In addition the furniture would be designed as formal transformations of the vocabulary found in the new building. The circular geometry found in the walls and barrel vaults would establish the place quality of the linear framework. The framework could also become a spatial territory establishing a place where fleamarkets might be held, each column or pier helping to define the zone of each merchant, and providing the beginnings of a temporary shelter. All of this would most importantly assist in the inhabitation and activity of the public street, a necessary prerequisite for making trips from one store or complex to another, an experience rich with the potential for social interaction,

69

visual interest, and market activity, as opposed to an episode of walking from one introverted building to another in which the experience of outdoor pedestrian or vehicular circulation offers absolutely nothing other than the space in which to travel, thus making the trip possibly not worth the effort.

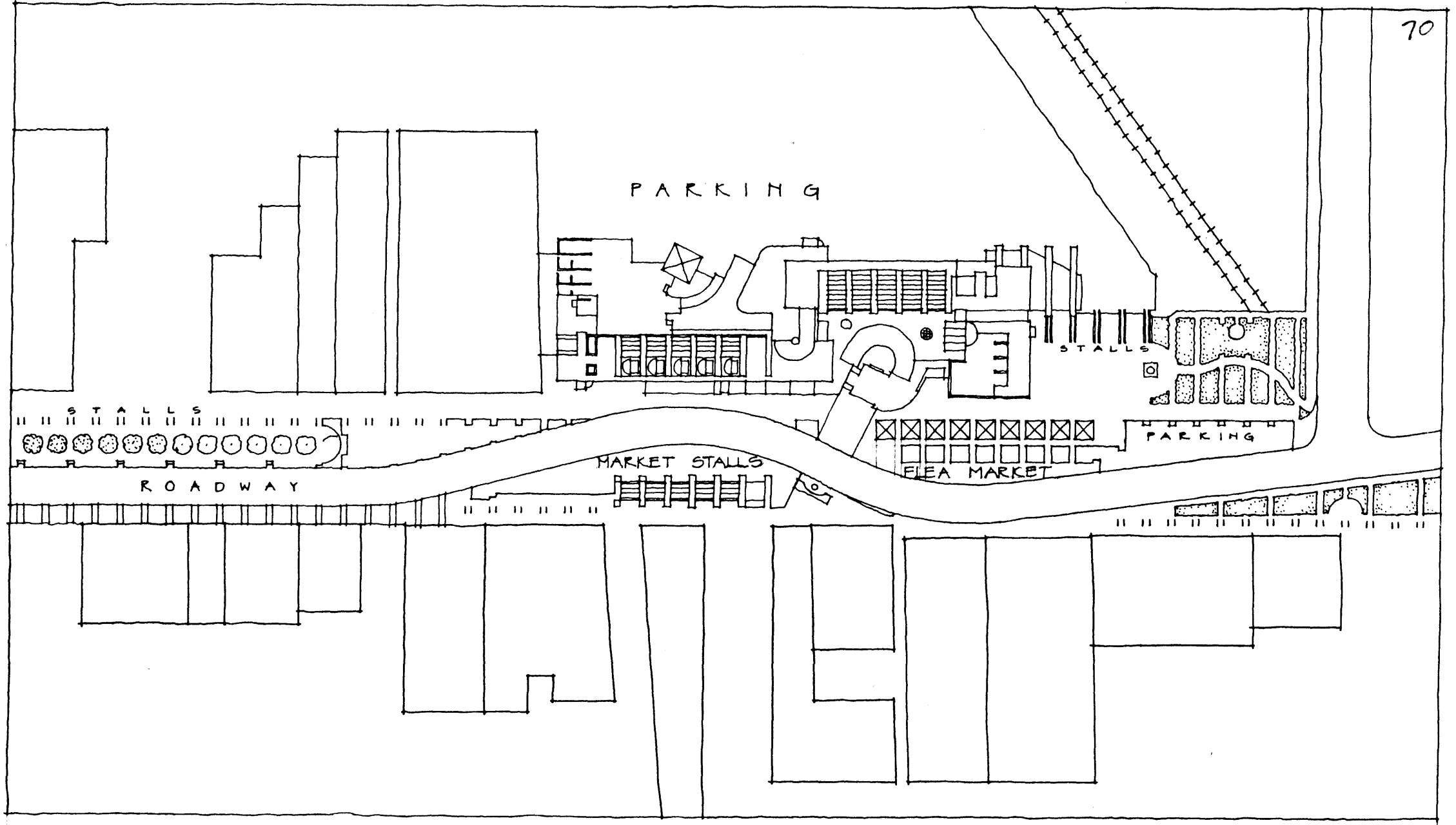

J L I T V N O I L C N U E
I L T U M

(5)

Pittsfield as it developed in the eighteenth and nineteenth centuries was not a city based on the notion of zoning. North Street has been, since 1761, not only a commercial zone, but also the center of various religious, cultural and recreational institutions. Before World War II the areas to the west of North Street were the site of some of Pittsfield's larger industries. Post World War II planning practices began the total commercialization of North Street. 100% commercialization has not happened yet, but development has continually gone in this direction. This zoned environment makes owning an automobile a necessity rather than a choice in an era in which energy conservation cannot be ignored, not to mention the fact that cars are not as affordable as they once were.

If Pittsfield is truly interested in the revival of its downtown it probably ought to consider developing it as a total community and not as a commercial zone separated from everything else. As many cities have witnessed, mechanized transport has become a destructive element in addition to being an economic liability. If markets for the commercial district existed within

walking distance of the commercial area, the parking issue would diminish in importance, and destruction of the city fabric to obtain space for vehicle circulation would not have to occur.

As an example of zoned planning, Berkshire Community College used to be located within walking distance of the North Street area, but city planners of the 1960's decided to move it about four miles to the west of the central business district. That meant either that the functions of eating or buying academic supplies had to be duplicated on the new campus, or more parking had to be developed behind North Street so that students and faculty members could drive into the city to obtain these services during lunch hours without being inconvenienced.

Pittsfield's planners should not look to the hinterlands for the majority of their shoppers. Instead, a development to increase the population of the downtown sector would be a more reasonable direction. Then the city would be truly independent of the threat posed by other regional malls located nearby. The convenience of being able to walk to shopping would outweigh the inconvenience and expense of getting in

one's car and driving to the shopping center. Shopping center development has been plagued by competition, especially in places like the mid-west where the newest shopping center is always the preferred place to go. Within a large region, say a driving range of 45 minutes, no two malls are seen to be any more or less convenient, one is just more jazzy or contemporary than the next. Malls that are in the range of being 3 to 5 years old experience a slackening in sales and eventually have to go out of business or spend a lot of money on pepping up the image of the place, whether the physical plant is actually deteriorating or not.

In addition to providing convenience, developing the city in a multi-functional manner allows hopefully for continuous 24 hour inhabitation of the downtown. Proximity of stores to night oriented activities such as entertainment facilities like bars, restaurants and theatres, in addition to residential activities, provides a kind of natural surveillance for these shops when they are shut down and vulnerable to being burglarized. But this example also works in reverse. Residences which are left unattended

73
during the day also become targets of burglary. Crime, especially burglaries, have increased in the suburbs more rapidly, in some areas of the country, than crime in the urban core. It is primarily due to the discontinuous inhabitation of these residential zones. From 8:00 A.M. until 5:00 P.M. many neighborhoods are empty, especially in areas with concentrations of families where both parents work and all children are in school. If housing is associated with some other activity besides itself, the daytime users of the other facilities can provide, at no cost, the surveillance of the residential property. This diminishes the need for an expensive security program of doormen, guard dogs, alarm systems and electronic surveillance.

Ideally, the commercial zone would be the workplace and residences of the same group of people, a model upon which almost all cities were based. Bern and Chester are examples. A sense of responsibility for the buildings and public spaces also develops, because the city becomes a direct extension of the territory of the city dweller's residence.

For this to happen, the city needs to become

an entity which provides not only the commercial and residential functions, but enough of a range of functions so that the opportunity exists for an urban dweller to fulfill most or all of his/her social, educational, cultural and other needs within walking distance. The nature of the commercial zone in a community such as this by definition becomes one in which the necessities of life; food and clothing are represented as much, if not more than fast food restaurants and gift shops.

Pittsfield, as it exists now, has the potential to become a place in which all of these functions exist. Within a ten minute walk of North Street, one can still find a hospital, an elementary school, a high school, a public library, city offices, a police station, churches and synagogues, offices, banks, a museum, a YMCA and a Girl's Club. Land that would be used for extensive parking facilities, as proposed by the Pyramid Corporation, could instead be developed into buildings which would not be economic liabilities, which would have been the case if Pittsfield had built the parking deck, but economic assets because of their taxability. In summation, the develop-

74

ment of a totally commercialized, car oriented project might, in the short run, give Pittsfield the economic boost that it needs, but as tastes and trends transformed, this economic boost would shift to other, newer areas, leaving Pittsfield with the same problem it faces today.

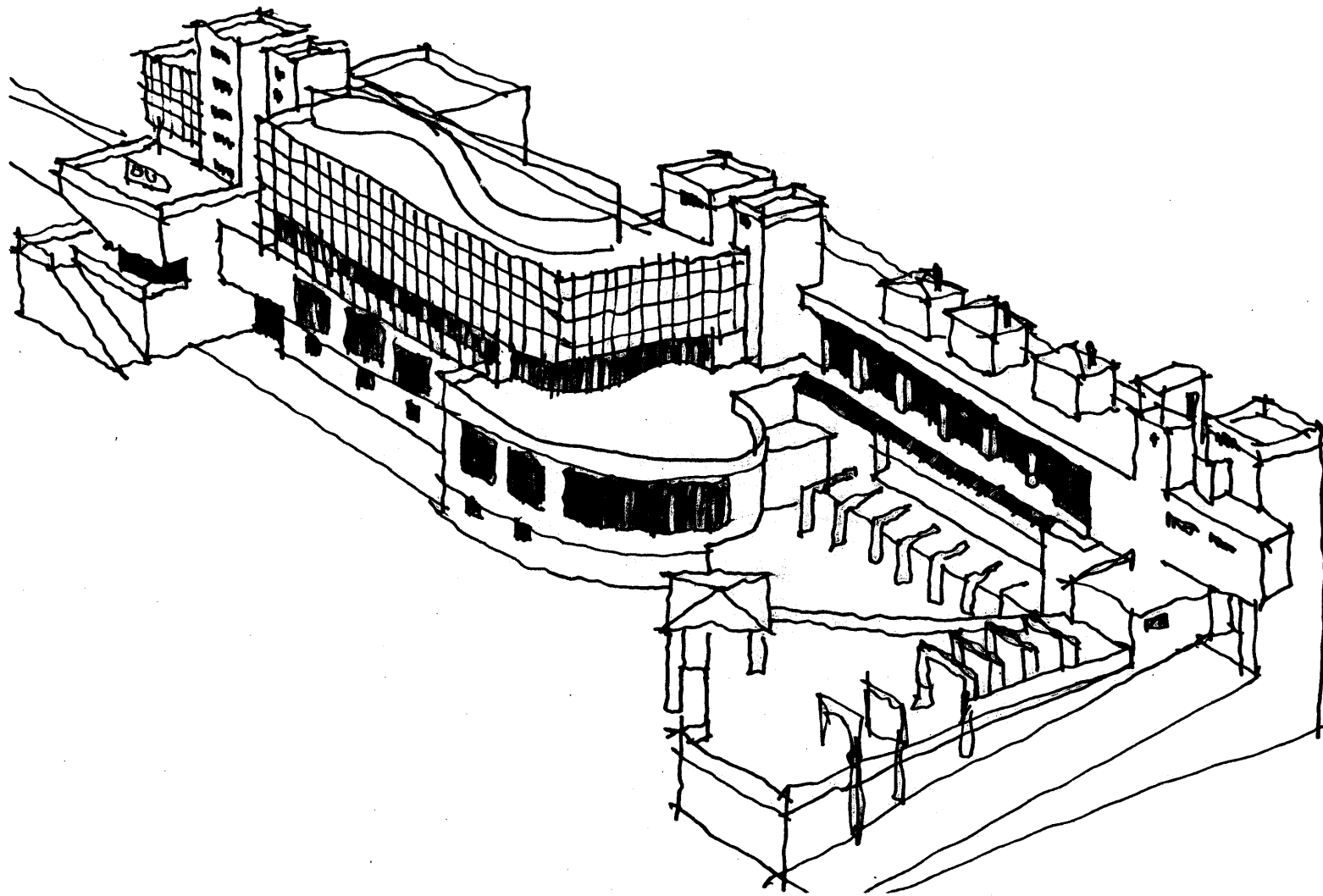

F I N A L D E S I G N

The final design was an attempt to integrate the concepts that had been discovered in the analysis of other shopping streets and their relationship to the city. The initial gesture was to put a building on the site that used the street as its front door and purposely did not spread the commercial environment into what is now the parking lot, which might have created a competing shopping street perpendicular to North Street. The primary goal was to make the new building continuous with the old buildings.

Shoppers arriving from the parking lot spiral up the circular ramp between the glass flower shop (square in plan) and the curvilinear form of a restaurant and its southwest facing deck. They find

76
themselves surrounded with the activity of an open market whose stalls are created from the unenclosed structural bays that project westward from the southern end of the new building forming an entry courtyard that opens up in one corner to allow passage onto North Street.

Consequently, before entering the new building, shoppers are made aware of the full extent of the North Street commercial district and then may choose to enter the new building or move on to older stores.

In addition to the court, the north end of the building also creates a passage up to the street with an L shaped ramp covered by the bulky volume of a cinema whose glass cage projection booth is displayed to the street providing a focus of interest for people within the

street.

The first and second floors are the commercial part of the building. A two story arcade snakes its way along North Street, supported by spatial piers which provide merchant stalls on the street side of the arcade, and turns in behind a semi-circular glass roofed auditorium which focuses the activity of the inside back out to the street. Upper floors provide loft space for artist's studios and offices on the southern end of the building and housing and offices on the northern end.

What finally seemed most important was that the building provide a view of its activities, circulation, displays, public events, and private outdoor activities to the street., so that the street

77

would become a place that would be desirable to circulate in. this would make trips to other stores desirable and it would turn the public space of the street itself into something more than just circulation. Instead it would be the city's living room, the space in which people meet and converse as much as circulate in. But for that to happen the action of shopping and other activities had to be their to draw people in.

Eventually the part of the site that had remained parking would be infilled with housing, the residents of which would use the street as their living room in addition to providing the market group for the commercial street. As mentioned before, survival of the commercial district would be based on the notion of provid-

ing a retail zone that was integrated with a series of other functions; housing, entertainment, offices, and outdoor public space. The convenience of walking distance proximity from non commercial activities to commercial ones would make North Street preferable to distant suburban shopping.

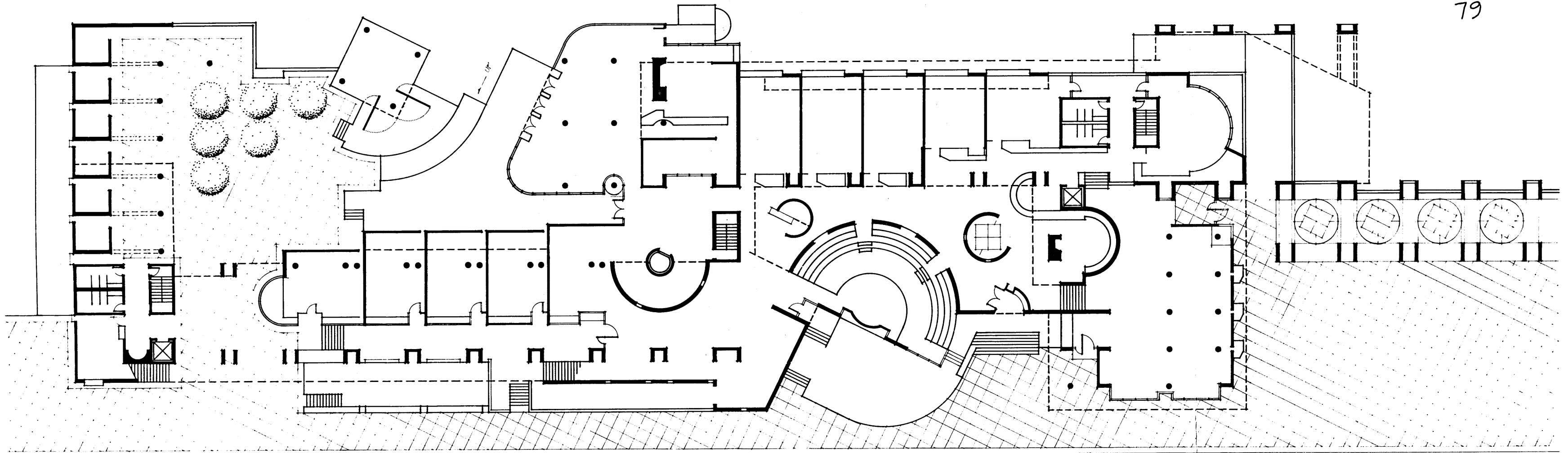

G R O U N D F L O O R 

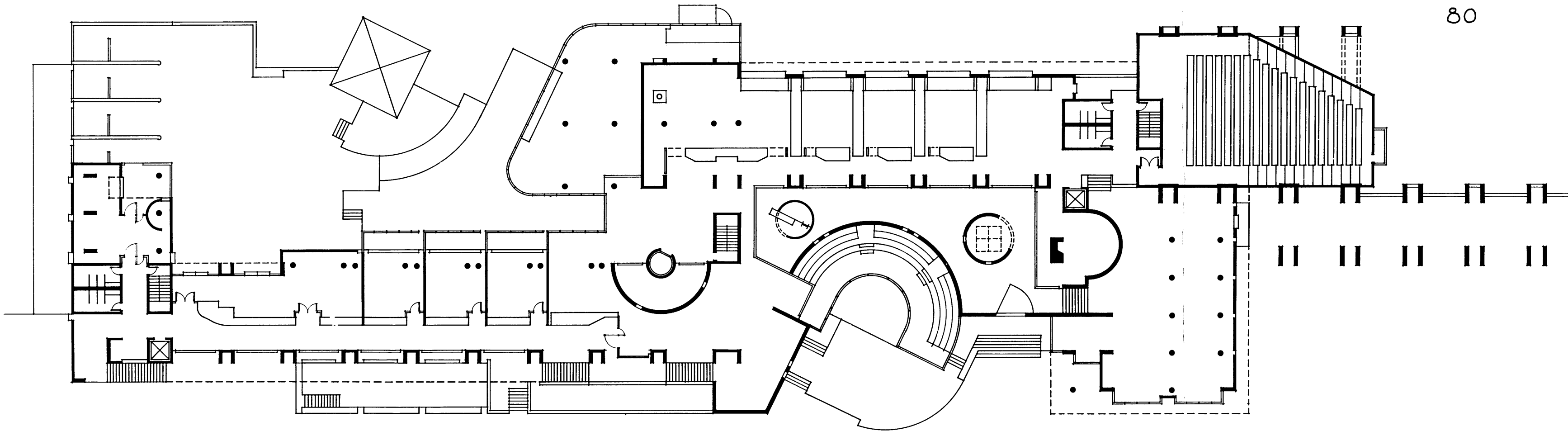

2ND
1 2 3 4 5 6 7 8 9 10 11 12 13 14 15 16 17 18 19 20 21 22 23 24 25

FLOOR



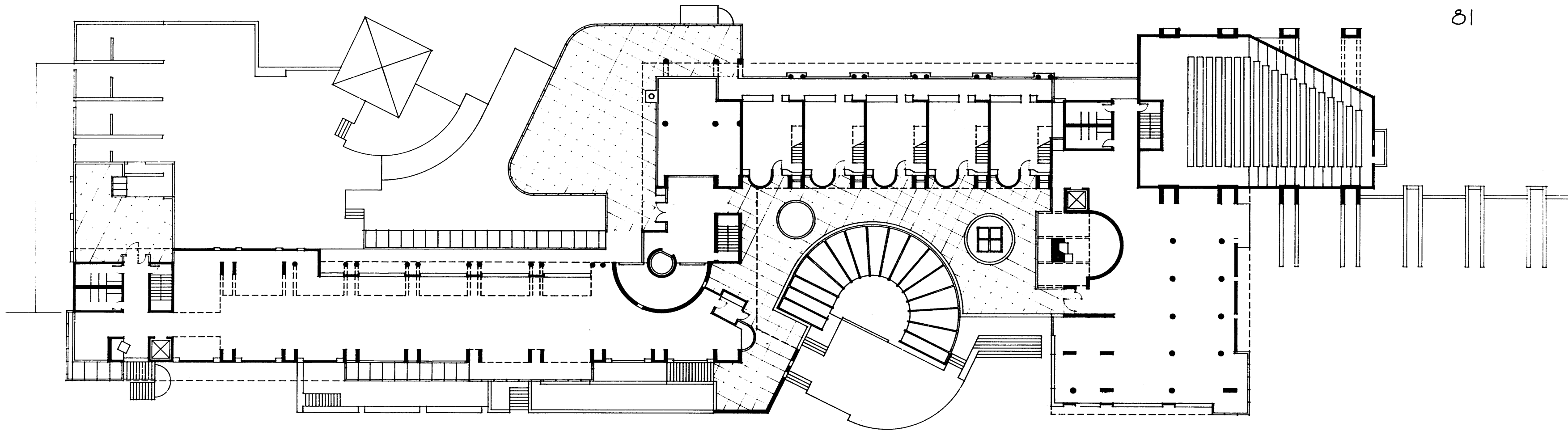

5 R D

F L O O R



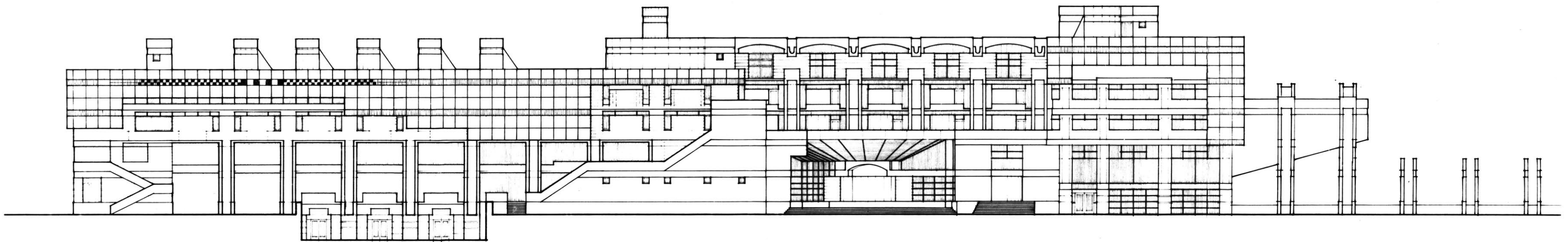

E A S T E L E V A T I O N

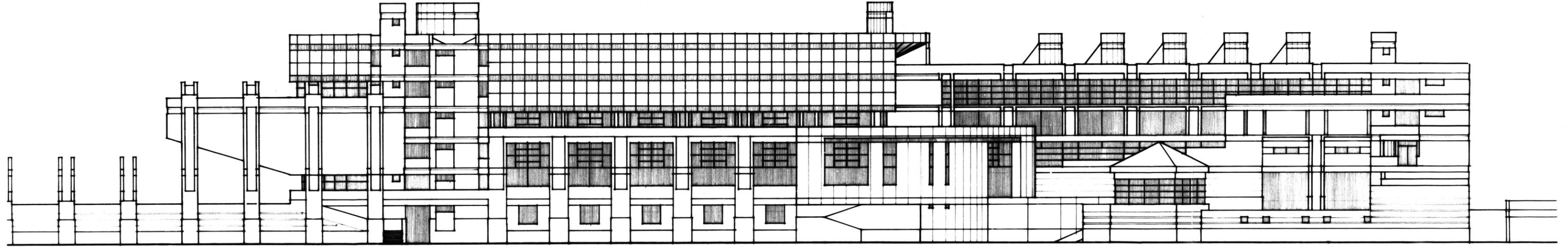

WEST ELEVATION

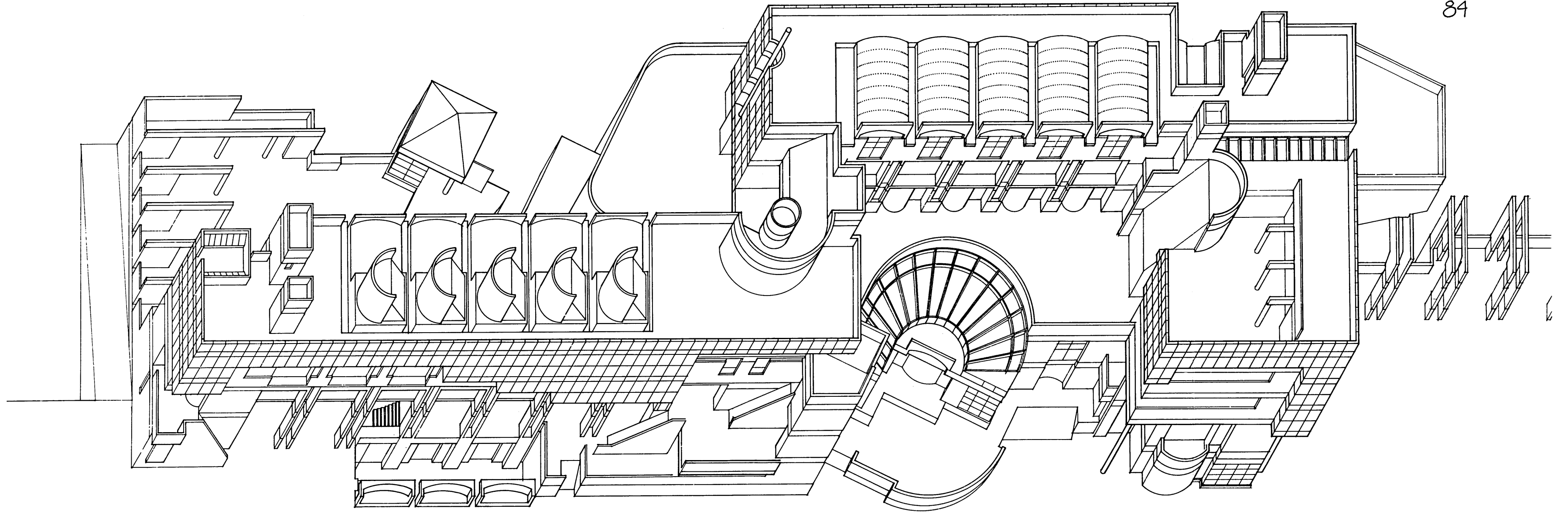

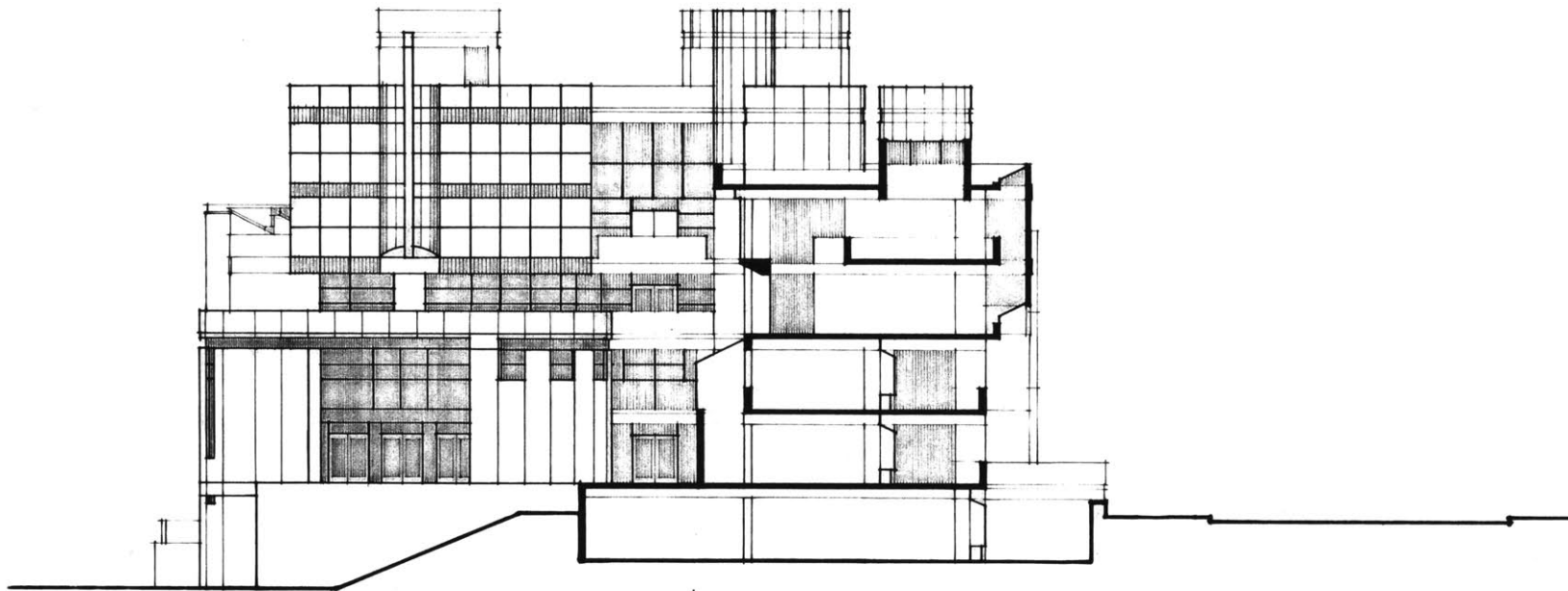

S E C T I O N A

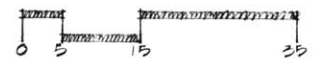

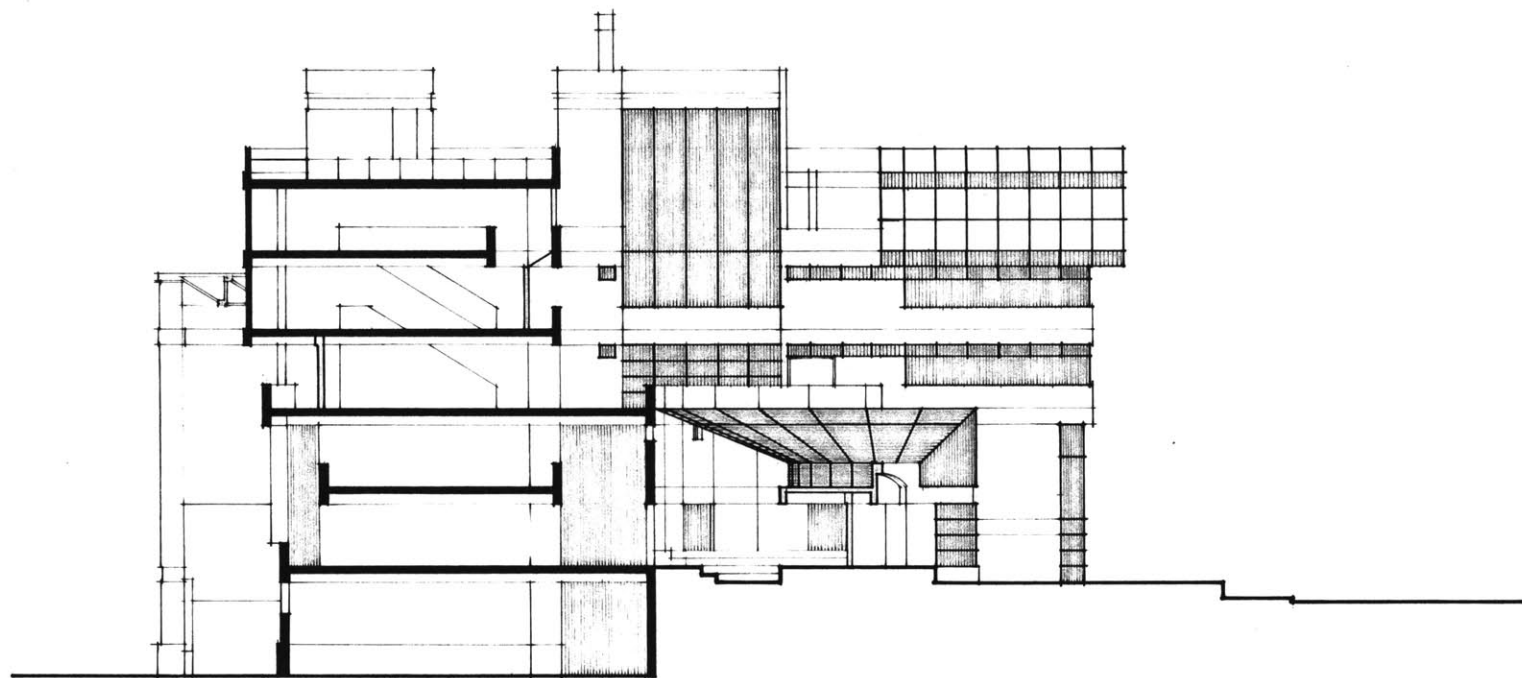

S E C T I O N B

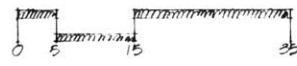

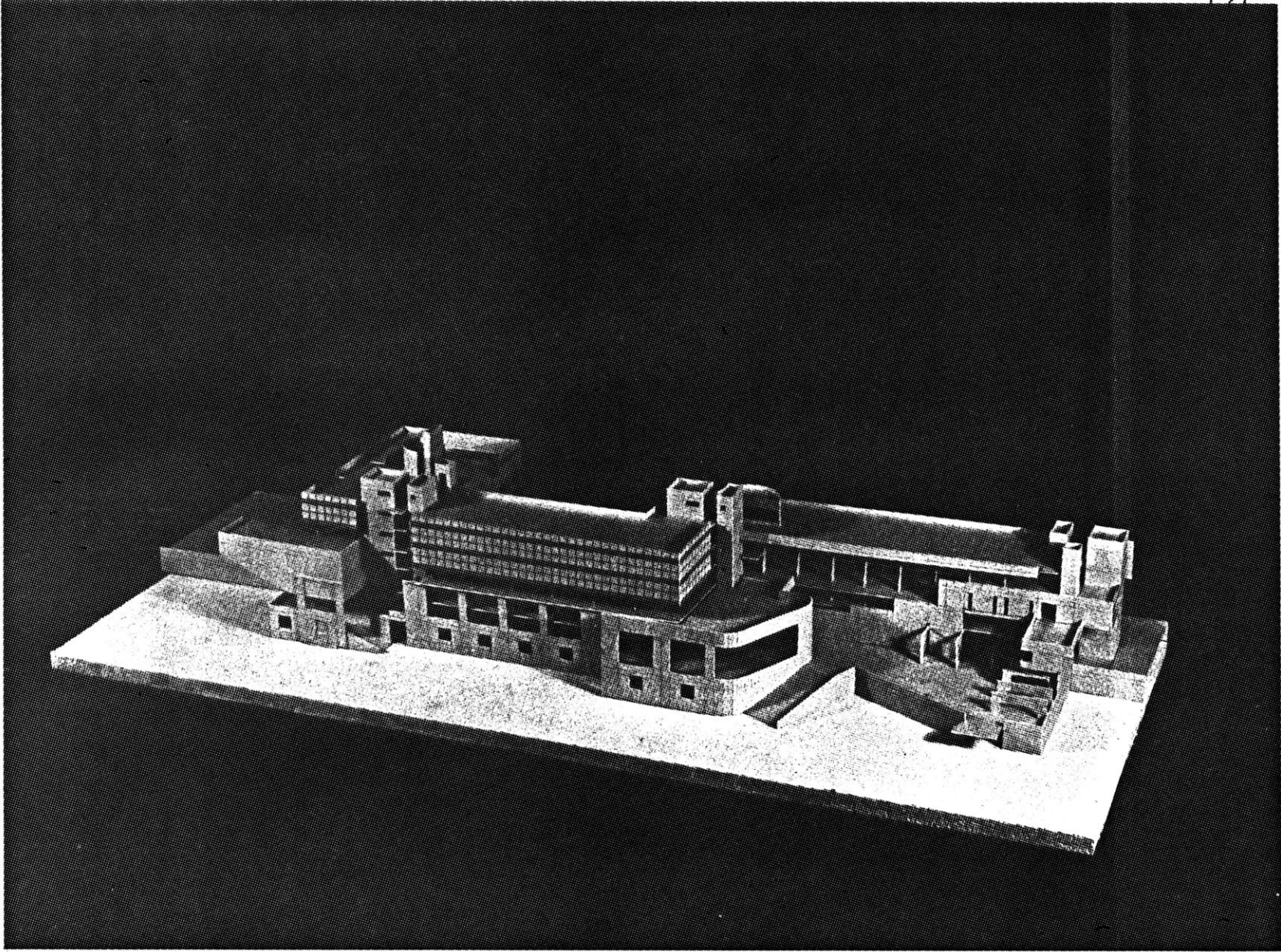

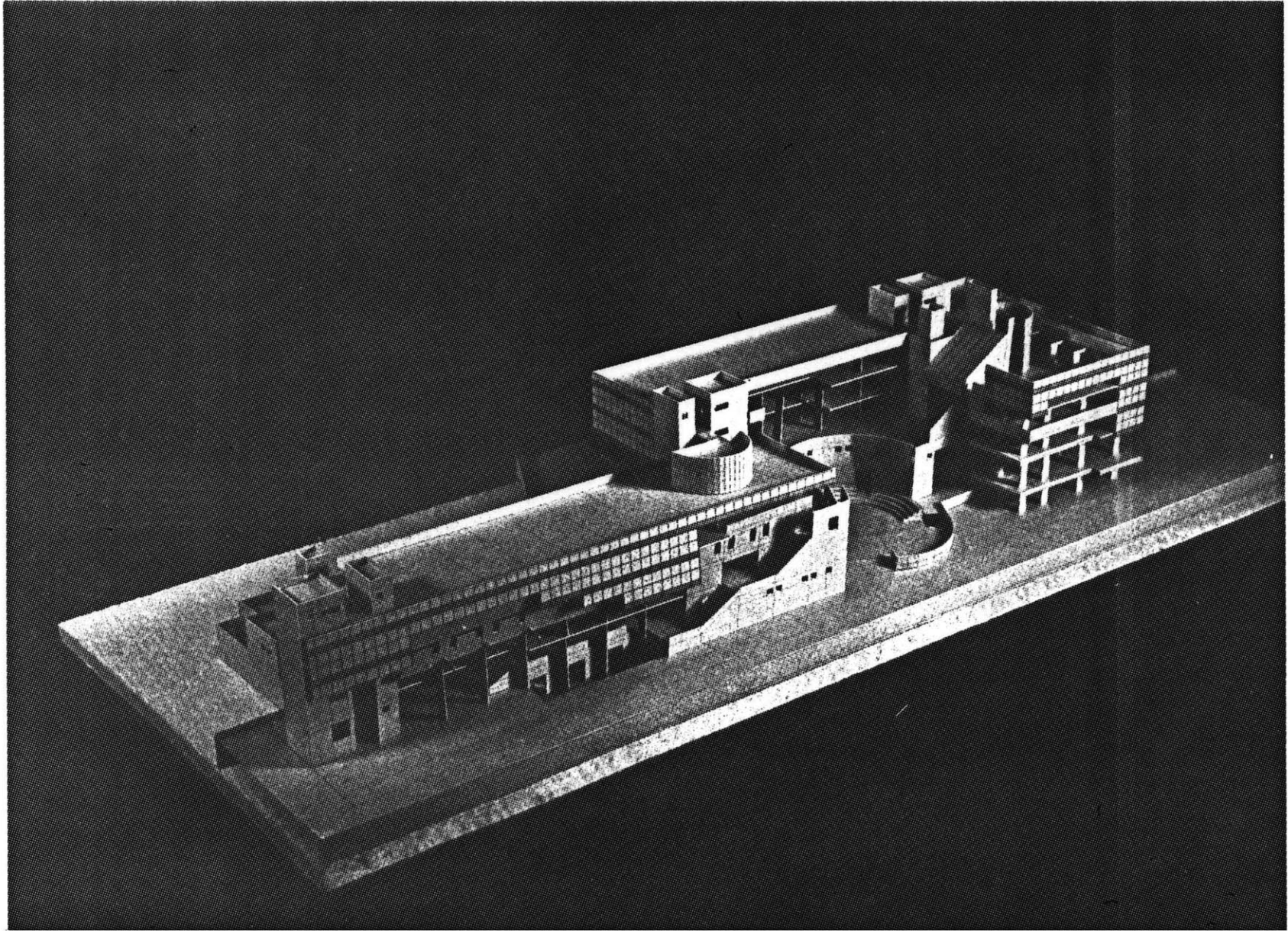

SOURCES OF ILLUSTRATIONS

90

1. OUR HISTORICAL RESOURCES, CITYSCAPE - COUNTYSCAPE, A HANDBOOK ON PLANNING FOR THE HISTORICAL LANDUSE QUALITIES OF PITTSFIELD and BERKSHIRE COUNTY, BY BARBARA BARROS, PAGE 87
2. NEW DIMENSIONS IN SHOPPING CENTERS and STORES, BY LOUIS G. REDSTONE, PAGE 147
3. MATERIALEN FUR STUDIE BERN, BY DOLF SCHHOEBLI et al, PAGE 118
- 4-6 NEW DIMENSIONS IN SHOPPING CENTERS and STORES, PAGES 240, 23, 151 RESPECTIVELY
- 7-19 PASSAGEN, EIN BAUTYP DES 19. JAHRHUNDERTS, BY JOHANN GEIST, PAGES 221, 221, PLATE 81, PHOTO 65, PAGE 21, PHOTO 139, PLATE 147, 150, 149, PHOTOS 244, 245, PAGE 197, PHOTO 99
- 20 CHESTER, A STUDY IN CONSERVATION, BY DONALD INSALL, PAGE 122
- 21 PASSAGEN, EIN BAUTYP DES 19. JAHRHUNDERTS, PAGE 52
- 22-27 CHESTER, A STUDY IN CONSERVATION, PAGES 85, 85, 129, 128, 85, 117

- 28 DIE SCHOENE STADT BERN, BY FRIDOLIN LIMBACH, PAGE 59
- 29 THE ZAHRINGER NEW TOWNS, BY ROLF HAGER, UN-NUMBERED
- 30-31 ERVIN GALANTAY, PROGRESSIVE ARCHITECTURE, DEC. 1967
PAGE 90
- 32-33 DIE SCHOENE STADT BERN, PAGES 120, 53
- 34-35 MATERIALEN FUR STUDIE BERN, PAGES 37, 78
- 36 BACK BAY BOSTON; THE CITY AS A WORK OF ART, BOSTON MUSE-
UM OF FINE ARTS, PAGE 81
- 37-38 PASSAGEN, EIN BAUTYP DES 19. JAHRHUNDERTS, PAGE 45
- 39 CSARDAS, BY V. MONTI, PAGE 2
- 40 BACK BAY BOSTON; THE CITY AS A WORK OF ART, PAGE III
- 41-44 LEON KRIER, A+U, NOV. 1977, PAGES 87, 92, 92, 91

BIBLIOGRAPHY

92

- BARROS, BARBARA; Our Historical Resources, Cityscape - Countyscape, A Handbook on Planning for the Historical Land Use Qualities of Pittsfield and Berkshire County, Pittsfield, Ma., City of Pittsfield, 1979
- GALANTAY, ERVIN; "Old New Towns" from Progressive Architecture, Dec. 1967, New York, Reinhold Publishing Co.
- GEIST, JOHANN; PASSAGEN, EIN BAUTYP DES 19. JAHRHUNDERTS, Munich, Prestel-Verlag, 1969
- GRUEN, VICTOR; Centers for the Urban Environment, Survival of the Cities, New York, Van Nostrand Reinhold, 1973
- GRUEN, VICTOR; Shopping Towns U.S.A., New York, Reinhold Publishing Co., 1960
- HAGER, ROLF; The ZHRINGER New Towns, Zurich, Swiss Federal Institute of Technology, 1966
- HAPPEL, RICHARD; Berkshire, Two Hundred Years in Pictures, Pittsfield, Ma., Eagle Publishing Co., 1961
- INSALL, DONALD; Chester, A Study in Conservation, London, Her Majesty's Stationery Office, 1960
- JONES, GUS; Environmental Programming: Faneuil Hall Market, Cambridge, Ma., M.C.P. Thesis at M.I.T., 1978
- KRIER, LEON; "A City Within the City" from A & U, Nov. 1977, Tokyo, A & U Publishing Co.s
- LEWIS, PHILLIP; Woodward Avenue, Detroit: A Pedestrian Zone for a Changing Downtown Retail Street, Cambridge, Ma., M. ARCH. Thesis at M.I.T., 1981
- LIMBACH, FRIDOLIN; DIE SCHOENE STADT BERN, Bern, Benteli Verlag, 1978
- PITTSFIELD, MA., CITY OF, OFFICE OF THE MAYOR; "Inner City Revitalization Program Case Report 106"
- REDSTONE, LOUIS; New Dimensions in Shopping Centers and Stores, New York, McGraw-Hill, 1973

SCHNOEBLI, DOLF (et al); MATERIALEN FUR STUDIE BERN, Zurich, Eidg Technische Hochschule, 1974-1975

SCHUMACHER, THOMAS; from On Streets, edited by Stanford Anderson, Cambridge, Ma., M.I.T. Press, 1978

SNYDER, WENDY; Haymarket, Cambridge, Ma., M.I.T. Press, 1970

STERNLIEB, GEORGE (Editor); Shopping Centers: U.S.A., New Brunswick, N.J., Rutgers, The State University of New Jersey, 1981

WARREN, GEOFFREY; Vanishing Street Furniture, Newton Abbott, England, David and Charles Ltd., 1978