

PASSIVE SOLAR / ENERGY CONSERVATION IN INDUSTRIALIZED HOUSING

by

Susan Marie Schneider

B. Arch., University of Notre Dame,  
1976

Submitted in Partial Fulfillment of the Requirements for the  
Degree of  
Master of Architecture in Advanced Studies

at the

MASSACHUSETTS INSTITUTE OF TECHNOLOGY

June, 1978

Signature of Author

\_\_\_\_\_  
Department of Architecture  
May 18, 1978

Certified by

\_\_\_\_\_  
Waclaw Zalewski, Professor of Design of Structures  
Thesis Supervisor

Accepted by

*S M* \_\_\_\_\_ *P*  
Julian Beinart, Professor of Architecture  
Chairman  
Departmental Committee for Graduate Students

© Susan Marie Schneider 1978

*Rotch*  
MASSACHUSETTS INSTITUTE  
OF TECHNOLOGY

AUG 10 1978

LIBRARIES

## ABSTRACT

PASSIVE SOLAR / ENERGY CONSERVATION IN  
INDUSTRIALIZED HOUSING

Susan Marie Schneider

Submitted to the Department of Architecture on May 18, 1978, in partial fulfillment of the requirements for the degree of Master of Architecture in Advanced Studies.

In the past century, buildings have been designed with little regard for their energy consumption. With the advent of the energy crisis, emphasis has shifted to the development of climate adaptive architecture which consumes less energy and relies on renewable natural resources.

This study investigates industrialized housing from a passive solar/energy conservation viewpoint. The study is divided into three sections:  
Survey This is a review of passive solar and energy conservation concepts that serve as general guidelines for creating energy efficient buildings. A series of sketches illustrate those concepts that are adaptive to northern climates.  
Proposed Method Industrialized construction for multi-family housing has inherent characteristics, requirements, and

limitations which necessitates adaption of passive solar/energy conservation concepts. These resulting methods are presented in drawings of energy efficient industrialized components.  
Prototype Incorporating the previously outlined concepts and methods, an industrialized housing system in precast concrete has been developed. Drawings illustrate passive solar heating concepts, site planning, unit plans, unit groupings and construction details of the prototype.

Thesis Supervisor:

---

Waclaw Zalewski  
Professor of Design of Structures

## ACKNOWLEDGEMENTS

I would like to thank the following people for their assistance in helping me to accumulate the information necessary for the completion of this study:

Eduardo F. Catalano, former Professor of Architecture, Systems & Industrialization Program, M.I.T.

Demetrios A. Criezis, architect, Eichsteadt Architects, Chicago.

Timothy Johnson, Research Associate, Department of Architecture, M.I.T.

Frank Williams, student, Department of Architecture, M.I.T.

Thanks to the Graham Fund for financing attendance at the Building Construction Exposition and Conference on Energy in Chicago, Illinois.

I would also like to thank Susan K. Funk and Leonard Picard for their help in the presentation portion of this thesis.

Especially, I would like to thank my thesis advisor, Professor Waclaw Zalewski, for his enthusiasm, constructive criticism, and continual guidance throughout the year.

This thesis is dedicated to my parents.

TABLE OF CONTENTS

4

INTRODUCTION	5
I. Background	
II. Government Energy Policy	
III. Construction Industry Response	
SURVEY	19
I. Energy Conscious Building	
II. Review of Energy Conservation Concepts	
III. Review of Passive Solar Design Concepts	
PROPOSED METHOD	65
I. Energy Efficient Industrialized Housing in Precast Concrete	
II. Integration of Energy and Industrialization Concepts	
PROTOTYPE	111
I. Energy Conscious Design Elements	
II. Industrialized Components	
III. Housing System	
CONCLUSION	150
APPENDIX	152
BIBLIOGRAPHY	155

# INTRODUCTION

## INTRODUCTION

### I. Background

Throughout history, man has been intimately linked with his environment. Past cultures understood their relationship with climate and built structures that were in harmony with it. With the advent of the Industrial Revolution in the 18th century, this relationship and understanding changed. The knowledge that had accumulated over the centuries was put aside in the name of progress. Industry requiring large amounts of natural resources developed rapidly until the limits of those resources were visible. At this point, an energy crisis materialized which forced contemporary man to reevaluate and recognize his link with environment. The principles understood in prehistory are now being

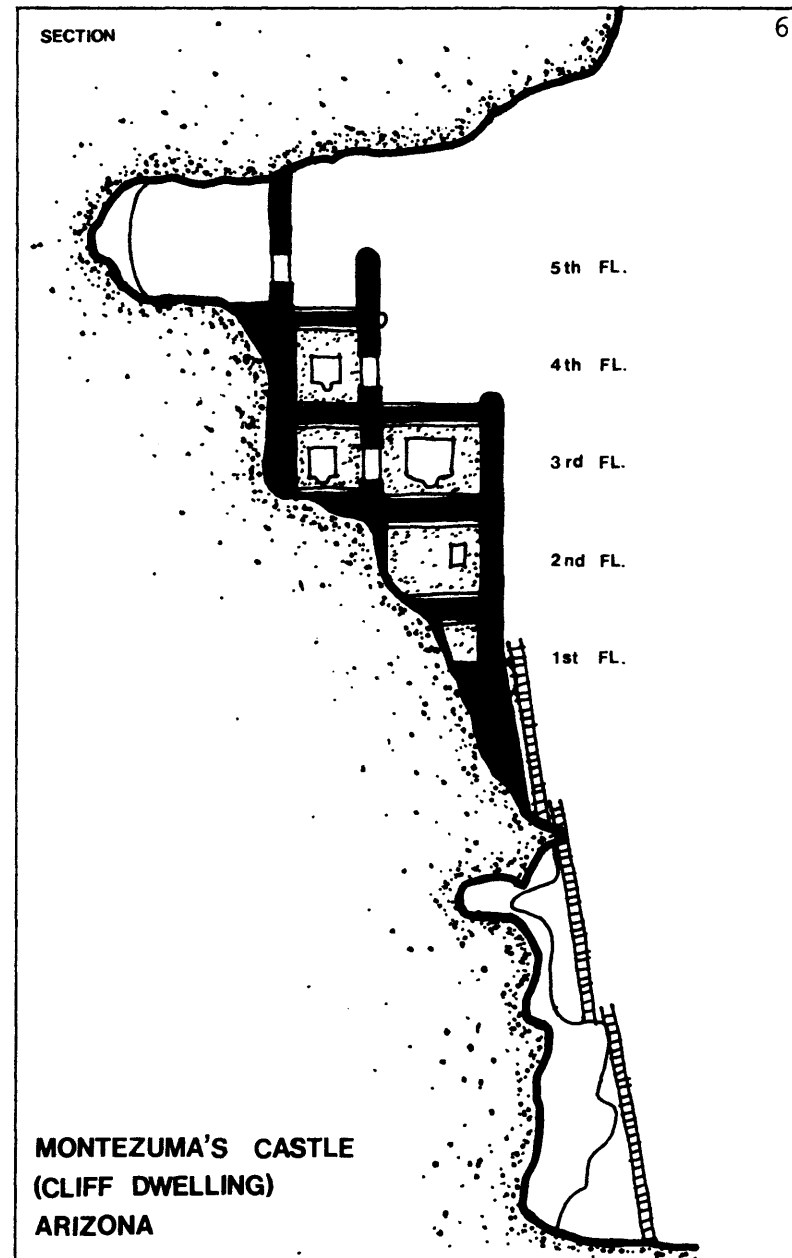

rediscovered and implemented in the built environment.

Primitive cultures had an understanding of their link with nature, and they sought to maintain that balance in the structures they constructed. They understood that the moderation of climate was the essence of shelter design. The sun was used to temper the indoor climate, and designs, materials, and orientations were chosen to maximize this energy source. Climate was the context within which the building functioned.

Basic techniques of adaption to climate evolved in these indigenous buildings. In the Arizona and New Mexico desert, Pueblo Indians built dwellings that provided comfort and shelter to the

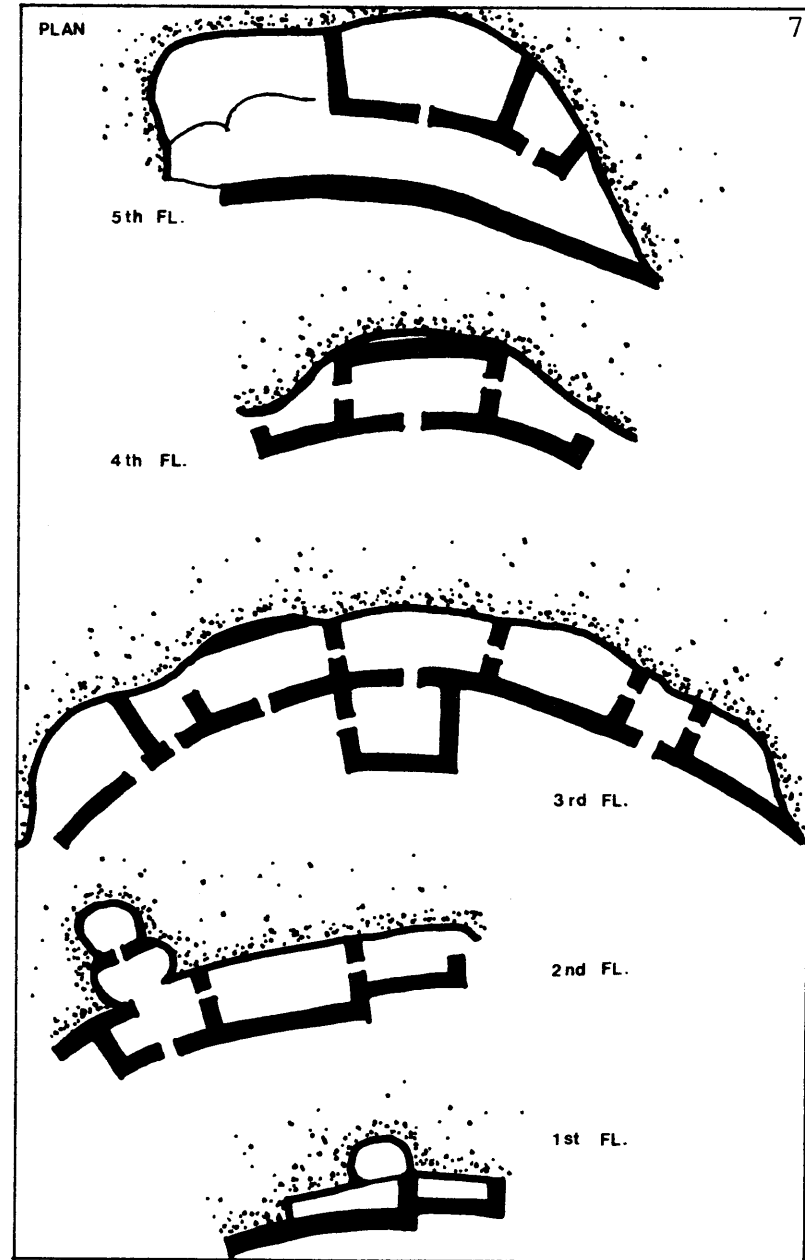

inhabitants through forms generated by response to their location. The Indians built thick adobe walls and roofs that kept the interiors cool during the day through absorption of the sun's energy. As temperatures dropped at night, the absorbed heat in the walls radiated to the interior space, warming the inhabitants. Communal buildings were oriented south or southeast to allow penetration of solar heat through walls and openings.

Early American pioneers built structures that were responsive to the cold climate of New England. Houses had masonry-filled walls and compact layouts to minimize heat loss during cold winter months. The kitchen with its continuously burning stove was located on the

north side of the house to allow the living spaces to occupy the southern exposure. Thus the house was balanced by the heat generating stove on the northern exposure and the solar heat gain through walls and windows on the southern exposure.

For thousands of years, this link between man and his environment remained unbroken. Other sources of energy were limited to human and animal labor, windmills, and waterwheels. In the eighteenth century, the internal combustion engine and various turbines increased the power available, the aggregate output, and fuel consumption. The Industrial Revolution was born and with it began the exponential growth of fuel consumption.



This phenomenal growth continued unchecked until recently.

The availability of energy was taken for granted as the average man became isolated from the intricate network of production and industry that server his comfort. The division of labor which resulted from the Industrial Revolution bred a shortsighted attitude in the consumer society that resulted in ignorance of man's position in the ecological system.

In the present century, the adaption of buildings to climate was ignored. With the evolution of high technology and the assumption that the energy required to support that technology would always be cheap and abundant, a complex architecture evolved based on

equally complex systems. The systems were contrived to control climate for human comfort, and buildings were viewed as individual hermetically-sealed environments.

Slowly this country has begun to perceive the environmental havoc that indiscriminate use of energy has wrought. This has been a result of dwindling supplies of fossil fuels which industry has come to depend on. An energy crisis has developed which has forced a revaluation of man's dependance on the environment. The crisis is a struggle to reduce a high energy habit and to obtain energy without becoming enslaved by debt. Buildings were built upon those technologies that contributed to the energy crisis.

With the end of inexpensive, non-

renewable energy supplies in sight, and with new and higher standards for the prevention of environmental degradation being accepted, the cost of energy has soared. Current projections of fuel demand exceed known and probable fuel reserves. The possibilities of exploring new energy sources such as the sun, wind, temperature gradients in ocean waters, geothermal energy, nuclear energy, and coal gassification has begun. The use of solar energy is becoming a workable alternative to the world's rapidly depleting energy supplies.

The sophisticated technologies that have been developed must begin to bridge the gap of history to past examples of architectural response to climate and environment. A new way of building must

be found, and earlier principles of indigenous structure must be rediscovered. Energy conservation and solar heating and cooling in construction could ease fuel shortages and environmental pollution substantially.

Solar energy is the most available and abundant potential source of energy. The amount of sunlight falling on the United States in a year is equivalent to seven hundred times its total annual energy consumption. Buildings can be designed to take advantage of this energy, to respond to local climates instead of creating a barrier against the environment, and to retain the energy they capture. The solution to survival in a finite world is through climate-adaptive building design.

## II. Government Energy Policy

In the United States, society has become dependent on an abundant and ever increasing supply of energy. Although this country contains only a small fraction of the world's population, it uses between one third and one half of the world's natural resources. A large portion of this consumption is energy. Presently, over 98% of this energy comes from fossil fuels such as coal, oil, and natural gas. The stock of fossil fuels is large but finite, and their continued consumption means living on the nation's capital. Eventually, this shortsighted use of coal and oil for the raw materials of industry will result in environmental degradation as the supply of non-renewable energy dwindles.

One third of the energy consumed in this country is used for heating and cooling the built environment. Housing is a major consumer of this energy, with current estimates calculating that 100 million households are consuming 20% of the national energy budget. Half of the energy consumed for residential and commercial buildings is wasted.

The diagnosis is dismal as the demand for energy continues to increase while world supplies of oil and natural gas diminish. The United States must make a rapid adjustment to the energy crisis before world oil becomes even more scarce and expensive in the next decade. There must be a concern for total consumption levels of petroleum and natural gas over time. The absolute levels of use must

stop rising and begin to continually decrease by the end of the century.

In response to this crisis, during the past year, the government has created a national plan for energy, research, development, and demonstration. The plan was concerned with the technological changes that the U.S. would have to allow to survive the period when world oil production approaches its capacity limitations. A further concern was with the transition to renewable, or essentially, inexhaustible sources of energy for the future.

Various parts of the government have been involved in this endeavor of working to develop a number of programs to increase the energy efficiency of the nation. The national energy plan was

conceived to meet three objectives:

- 1) to reduce dependence on foreign oil and vulnerability to supply interruptions,
- 2) to keep U.S. imports sufficiently low to survive the change in world oil production when capacity limitation is approached, and
- 3) to have renewable and essentially inexhaustible sources of energy for sustained economic growth.

There are various government strategies and objectives in carrying out this energy plan. Affecting the construction industry the most is the national objective of developing new technology to increase the efficiency of energy use, expand the use of existing fuels, and make the transition to new fuels. It is

believed that increasing the efficiency of energy use, conservation, can have the greatest impact on the nation's energy system between now and the end of the century.

To achieve national conservation of energy, three types of action are required in the plan. The first step is the promotion of an energy conservation ethic to reduce the demand for energy. The conversion of facilities and equipment to provide the same energy services with less energy is the second step. For architects and engineers, this would mean constructing buildings that are more energy efficient. The final action required to achieve national conservation of energy would be the development of new energy-efficient methodologies and tech-

nologies that conserve energy by using it more efficiently or by using more abundant or self-renewing sources of energy.

Over the long term, energy conservation can play a critical role in limiting the environmental consequences of the growing world-wide use of energy. The construction industry should be at the forefront of this national directive.

Many methods are being used to encourage or enforce the desired conservation actions. Public persuasion, regulation, and the creation of economic incentives are some of the means being followed. Regulatory measures to motivate conservation involve standards requiring the use of energy efficient systems, rationing of scarce fuels, and limitation of available resources. For architects

and engineers, this is translated into building regulations that are now being written and adopted by individual states. A model energy conservation code for new building construction is being formulated by officials representing the construction field. Two major purposes are hoped to be achieved by the code. One aim is to provide energy conservation standards for new building construction that are based upon technical criteria. The second is to take into account codes reflecting concern for energy conservation that have already been developed by various model code groups. Energy conservation is a new factor in building design, and building code officials are hurriedly trying to remain abreast of new construction practices.

The construction industry has been primarily concerned with solar energy, energy conservation, and building occupancy use. In Federal construction, there has been a turnaround in the method of providing space for Federal employees. All new buildings are being designed with high energy standards and the feasibility of including solar energy systems has become part of the design phase. Buildings are now designed to consume 40-50% less energy than buildings constructed three years ago.

As an outgrowth of governmental energy regulation, there will be increased concern for establishing standards of efficiency and requirements. Energy audits will be offered along with tax credit packages. Utilities will be

important and tax standards will be applied. Insurance rates will be a factor in programs for energy conservation. Many changes will result from the National Energy Plan now being introduced, which will have enormous repercussions on the construction industry.

### III. Construction Industry Response

With the onslaught of the Arab oil embargo, the construction industry was faced with the energy crisis. Prior to this time, the industry had developed in an era of cheap and abundant fuel. Priorities are gradually changing, but change demands immense capital outlays which encourage a reluctance to change. The government, through its National Energy Plan, is encouraging such change.

The building industry is today in partnership with the government whether it wants to be or not. The administration's energy policy has great influence on construction in general, and building construction in particular. Presently, the industry is concerned with solar energy, better construction methods, and

new methods of dealing with energy loss. There are reservations among architects, engineers, and builders concerning the use of solar energy, some of which are the initial cost, length of payback period, standards of product quality, and a lack of experience with the new systems. Much more faith is placed in sound energy conservation practices rather than new systems. A lack of information and facts on solar energy use, coupled with the belief that government claims are inflated about solar efficiency, have influenced the direction toward passive solar systems and energy-conserving construction techniques. Factors such as siting and building mass are felt to have importance over solar collection systems.

Incentives for becoming involved in



the design of energy-efficient buildings are increasing very quickly. Architects, engineers, and owners are now having to cope with engineering costs high enough to change the cost equations, with growing consumer expectations, government controls, and codes.

Architects and engineers are the key to widespread use of solar energy to heat and cool buildings. The integration of solar energy into the design and technology of buildings will make the solar industry a reality. By using proven technologies to utilize natural resources more efficiently, buildings can be adapted to their environment. This would be accomplished by emphasizing reliance on renewable rather than non-renewable resources.

In the next few years, solar water and space heating systems, both passive and active, are expected to compete with fossil fuel-based systems on a life-cycle cost basis. Already the debate has begun on what to do first to gain the maximum impact. Cost-effective priorities have become entwined in the practical considerations of applying the current state of solar technology.

A number of studies and demonstrations have been directed to the problem of reducing the amount of energy consumed in the housing stock. Most have suggested that a 25% to 35% reduction in the heating component is possible by making fundamental construction improvements such as upgrading insulation, adding weatherstripping and double-glazing, and

by being conscious of energy use. If Architects went beyond the fundamental construction improvements, the energy savings would be significantly extended. Natural energies such as the sun and wind would have to be fully understood and responded to, through passive design in all phases of planning, design, and construction. Many of the climate-adaptive principles used by ancient cultures in their structures are now reappearing in energy efficient designs responding to present-day energy limitations.

**SURVEY**

## SURVEY

### I. Energy Conscious Building

In response to the energy crisis and government urging, the building construction industry has been concerned with decreasing the amount of energy consumed by buildings. Active solar energy systems, which employ new technologies to collect and store the sun's energy, are still in the developmental stage. Eventually through additional research and testing, they will become more cost-effective and reliable. Presently, the major focus is on reducing the amount of energy a building consumes, to lower total energy costs. This is done in two ways by using the structure to collect and to store the sun's energy. In indigenous architecture of past civilizations, this

concept was the primary generator of building form. The climate and sun energy were maximized to attain the comfort necessary for the inhabitants. Once again, these principles are being studied and employed in new buildings.

The two general categories of methods used to reduce energy consumption in buildings are energy conservation and passive solar design. These concepts overlap and interconnect to the extent that it is difficult to consider them individually. An energy conscious building uses every effort in planning, design, and construction to minimize heat loss in the winter and heat gain in the summer. This is done by using energy-conserving construction characteristics, providing additional energy conservation by incorpor-

ating passive design ideas, and by using solar energy through passive systems in the planning, design, construction, and use. These techniques are used according to their contribution to energy consumption and conservation.

The goal of an energy conscious building is to reduce the amount of energy a building needs to provide thermal comfort for the inhabitants. The additional required energy is then less, whether it is supplied by renewable or non-renewable sources. In an energy conserving building design, the architecture is consistent with the climatic conditions and is essential to reducing the energy requirements for human comfort. Reducing the energy requirements is essential to reducing the cost of solar

energy systems. It is possible to achieve 60% savings in energy over conventional construction by careful attention to energy conserving environmental systems.

In energy conscious design, the entire building must be considered as a whole, as a system in which there is interaction among the building envelope, the structure, the mechanical and electrical subsystems, and the users of the building. The passive solar and energy conservation concepts which are utilized in energy conscious design can be divided into two primary areas: the use of the building as a collector for direct gain of solar energy, and the use of special building elements for indirect or isolated solar gain. Energy conservation concepts are primarily direct gain methods

and passive solar concepts involve direct indirect, and isolated gain methods. Realistically, it is difficult to categorize energy conservation and passive solar energy concepts because of their interdependence.

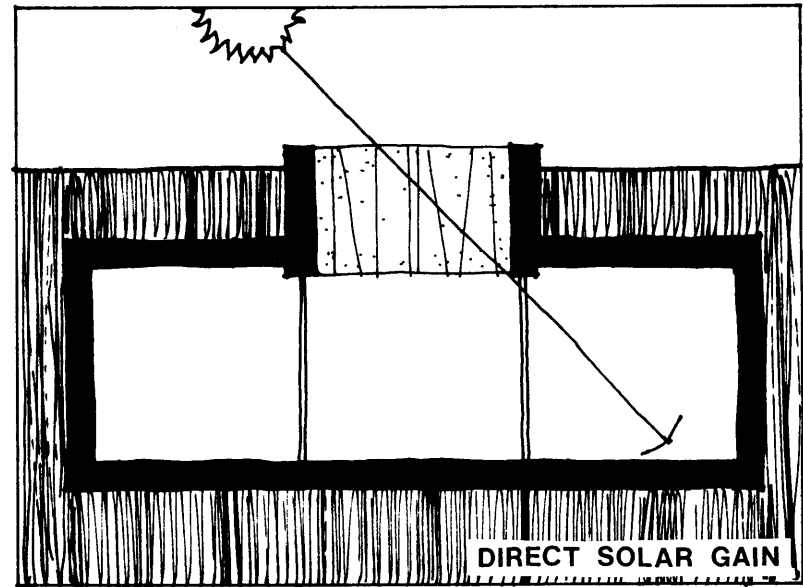
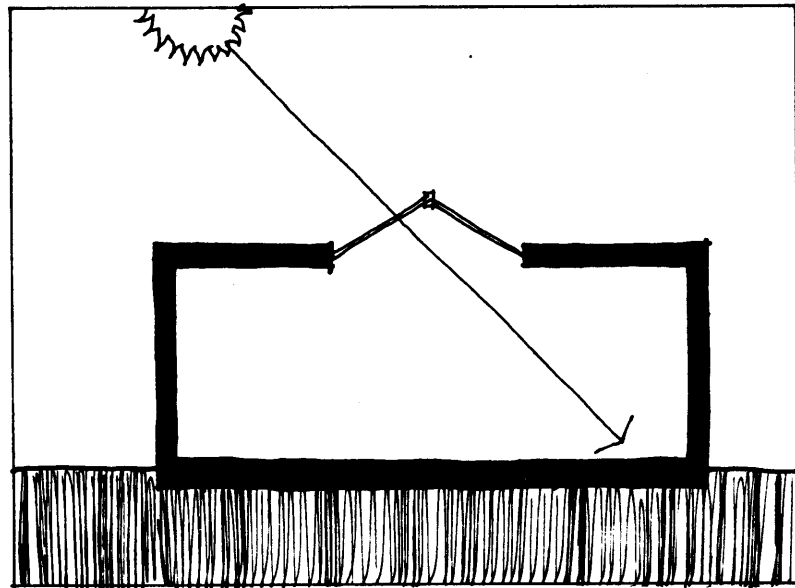
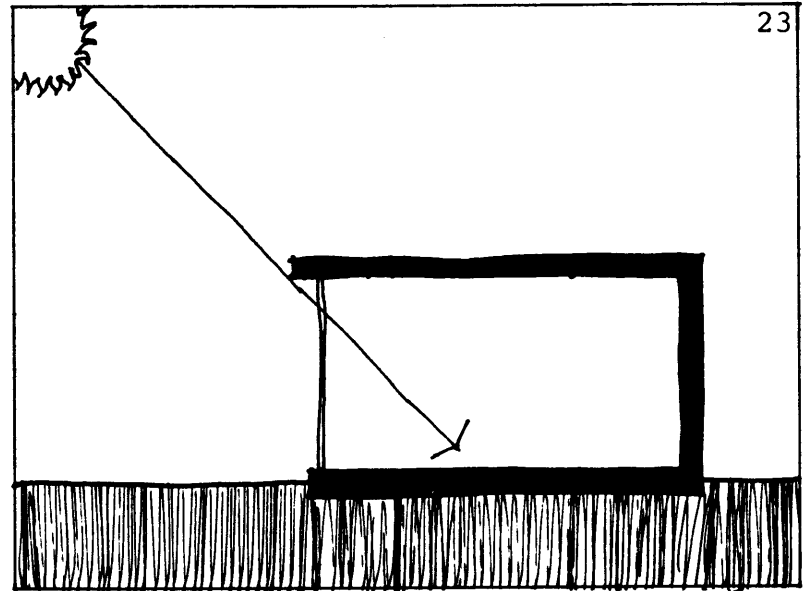
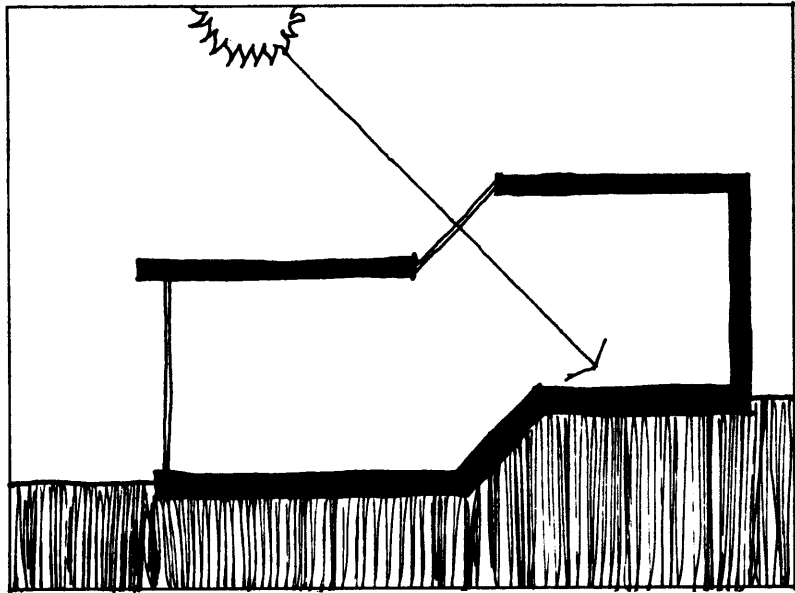

## II. Review of Energy Conservation

### Concepts

Energy conservation concepts, which are generally direct gain methods, use the sun's energy to heat a building by allowing it to penetrate directly through the roof, walls, and windows. Solar heat is then trapped inside the structure.

This is accomplished by energy conservation in the:

- 1) site analysis
- 2) building orientation
- 3) building configuration
- 4) building envelope
- 5) glazing type and location
- 6) sunshading devices
- 7) space planning
- 8) ventilation

The energy a building uses is related to these individual factors. Due to their interrelationships and interdependence on

each other, the factors influence the energy savings of each individual one, hence they cannot be considered alone.

#### 1) Site Analysis

Energy conscious design begins with the site: its location, layout, and orientation. The key energy-related objectives in site planning relate to orientation for solar gain (to capture heat when needed) and orientation for breezes (to provide natural ventilation when needed). In designing for a temperate climate in the Northern Hemisphere, the geographical location and climate are extremely important.

guidelines:

- A. The dimensions and shape of a site should be used to achieve a building configuration that will provide maxi-



imum energy advantage. The shape of the site could affect building shape and orientation, thereby influencing the energy consumption of a structure.

B. Natural features, such as wind patterns hills, and vegetation could influence building location, orientation, and proportion. The sun heats the east, west, and south slopes of a hill, while northern slopes remain shaded. The north and west sides are also the most exposed to wind loads.

C. Earth berming on the northern orientation can be used to decrease heat losses through the building envelope. A sod roof over an existing roof would provide extra insulation. The insulation value of the earth would depend upon the moistness and compactness of the

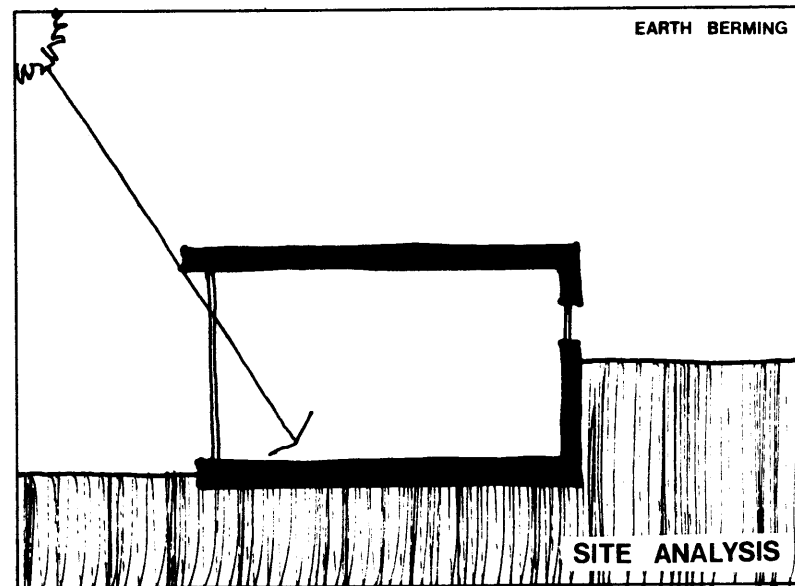
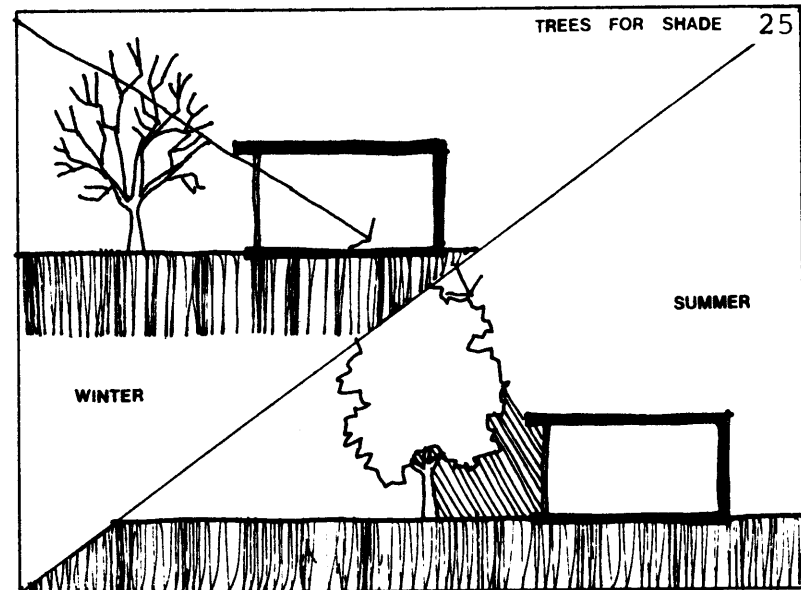

soil. For earth berming, the method of excavation should be cutting and berming.

D. Deciduous trees on the south orientation will provide sun in the summer and permit solar penetration in the winter.

E. Coniferous (evergreen) trees located on the north and west orientations will block arctic winds.

G. Hedges can provide ground level shading on the east and west exposures. Deciduous or coniferous hedges would depend upon solar and wind patterns.

H. Trees, hills, and other buildings should be located to avoid casting shadows on south-facing glass during the winter.

I. Concrete paving next to a build could

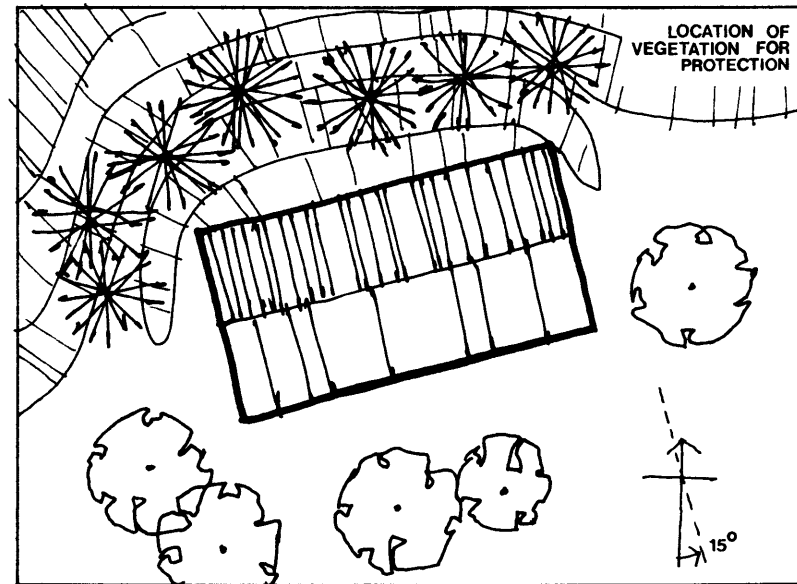
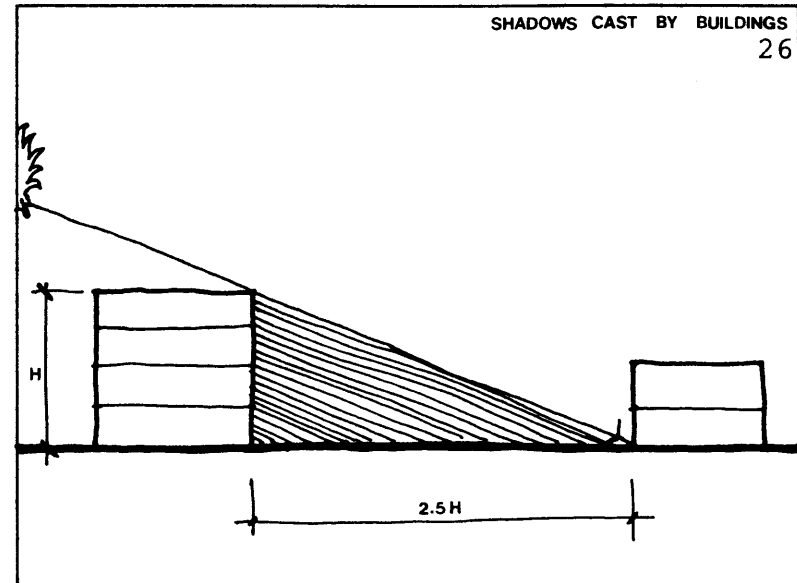

could increase heat radiation on the south, and east facades in the summer. Reflective surfaces of other buildings or pavements may lessen or increase cooling loads.

## 2) Building Orientation

Orientation is one of the most important principles in energy conservation design. Each building facade experiences different climatic conditions which have a strong effect upon energy consumption depending upon climate, site, and geographic location. To collect or reject the incoming solar radiation is the primary consideration, and in cool and temperate regions, the building orientation should maximize solar energy collection by passive devices.

guidelines:

- A. The sun has greater influence than wind on building design and energy consumption. All exposures other than the northern one receive varying degrees of solar radiation. Eastern exposures receive the low intensity morning sun, while the roof and southern exposures receive the maximum solar intensity in the afternoon. The western exposures receive the less intense evening sun. In descending order of solar radiation intensity on the four orientations are: south, east, west and north.
- B. The principal facade of a building should face within  $30^{\circ}$  of due south (between south-southeast and southwest). Orientation east of south will

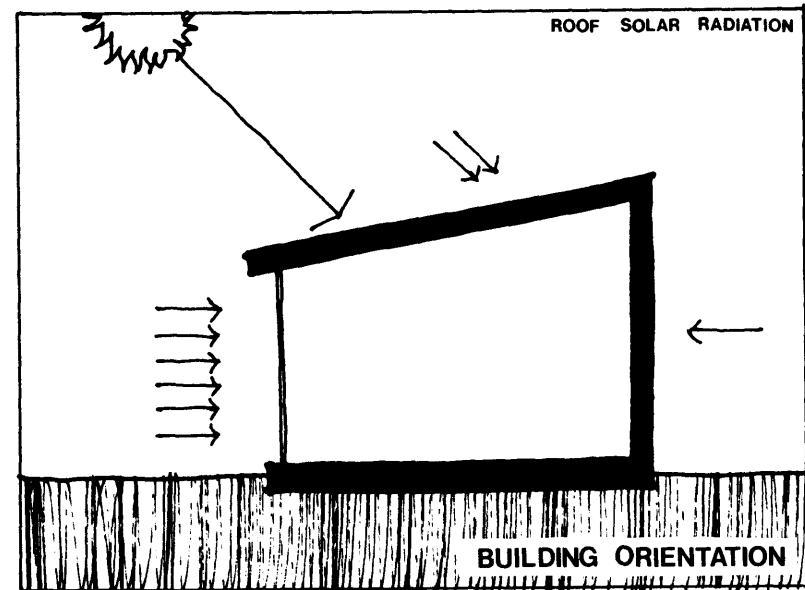
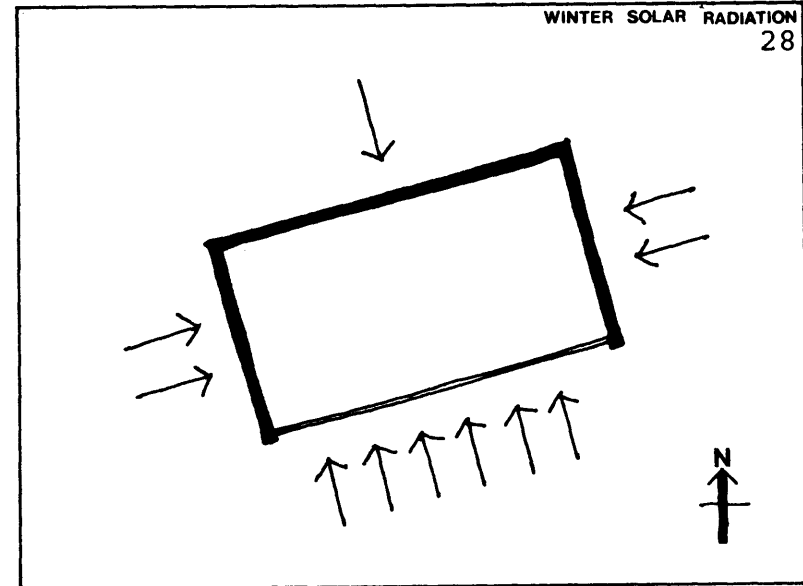

- increase the advantage of morning sun.
- C. Roof slopes should face south for heat gains.
  - D. An east/west building orientation is best for solar gain, with the longest facade on the south/north sides.
  - E. For increased natural ventilation, the facade through which breezes will enter should be located at an angle of  $20^{\circ} - 70^{\circ}$  between the wall and the wind direction. Turbulence will be increased and better insulation provided.
  - F. Entrance and glazed areas should be oriented away from the prevailing winds to avoid leakage around doors, windows, and other openings. Entrances on north or west sides should be shielded.

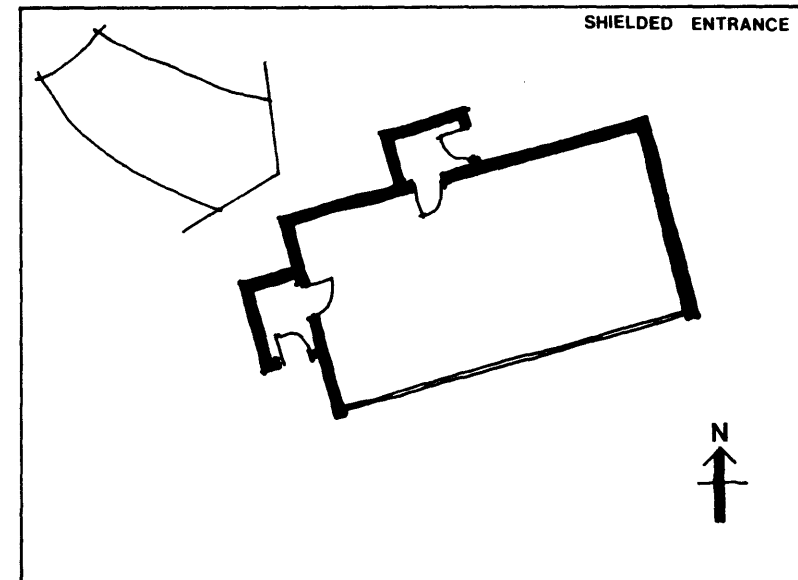
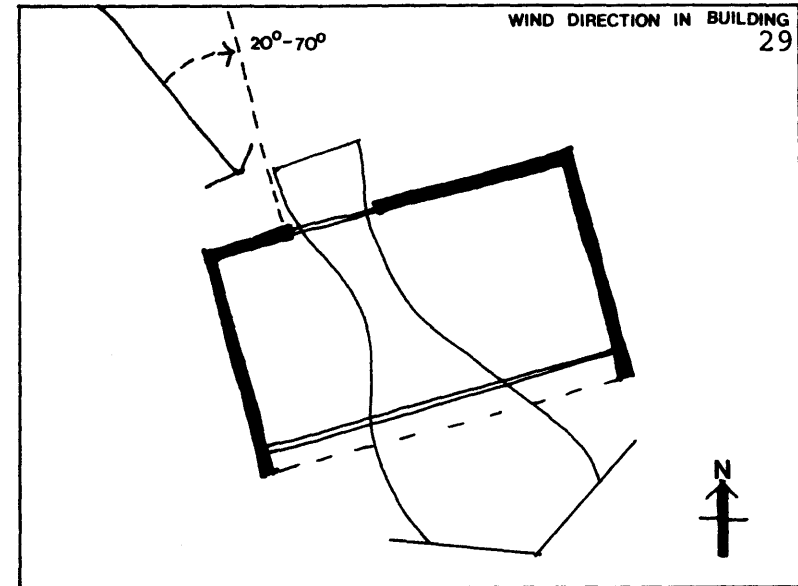

### 3) Building Configuration

Overall building configuration has strong impact on energy consumption. The volume of space to be heated and cooled, the amount of disposition of exterior surface area, and the degree of room exposure contribute to energy requirements. The major variable affecting the heat loss or gain is the amount of exposed exterior surface area.

guidelines:

- A. A spherical building is the most energy efficient shape possible. It has less surface area than any other shape for an equivalent amount of volume. A circular floor plan has less wall area, hence less heat gain or loss, for the same square footage of floor area in another shape.

B. Pyramids, rhomboid-shaped buildings, and other forms can be used to control the influence of climate on energy consumption.

C. A square building has less surface area than a rectangular building of equal volume, but is not the optimum energy efficient form.

D. A long, low building has the most heat loss of any building form because it may have a greater roof area in proportion to wall area. The roof has a strong influence on total heat loss and gain.

E. A tall building has a proportionately smaller roof and is less affected by solar gains on that surface. At the same time, tall structures are subjected to greater wind velocities

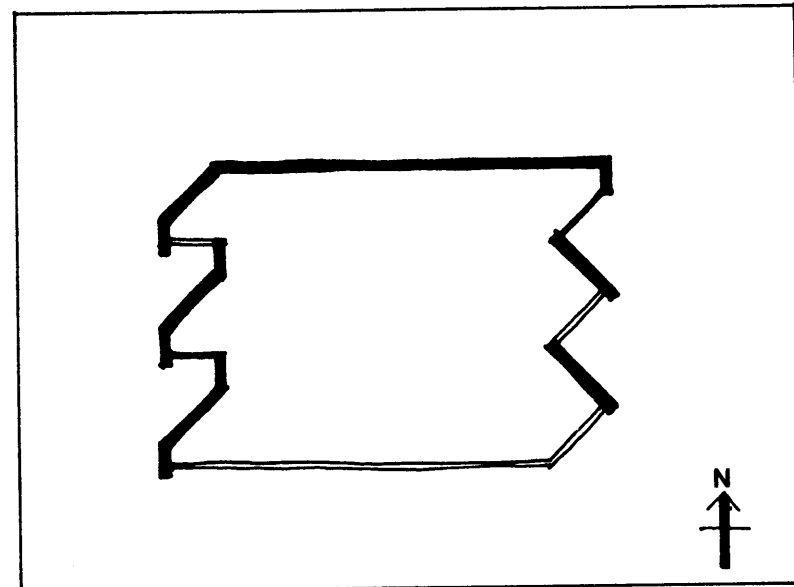
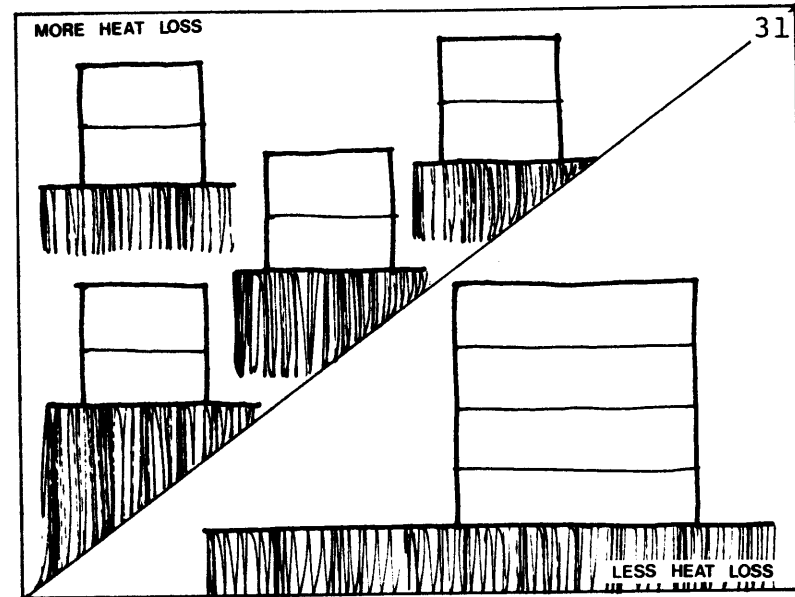

which increase infiltration and heat losses, because of less protection by surrounding buildings and trees.

F. The optimum energy-efficient building shape is a form elongated along the east/west direction to take maximum advantage of the solar gain on the south facade. If possible, the south facade should be considerably larger than the other facades.

G. A spherical section on the northern orientation will incur the least possible heat loss per enclosed volume.

H. One large building is more efficient than many small buildings because there is less surface area. A simplicity of form is important for energy reduction.

I. Buildings on stilts, or buildings with

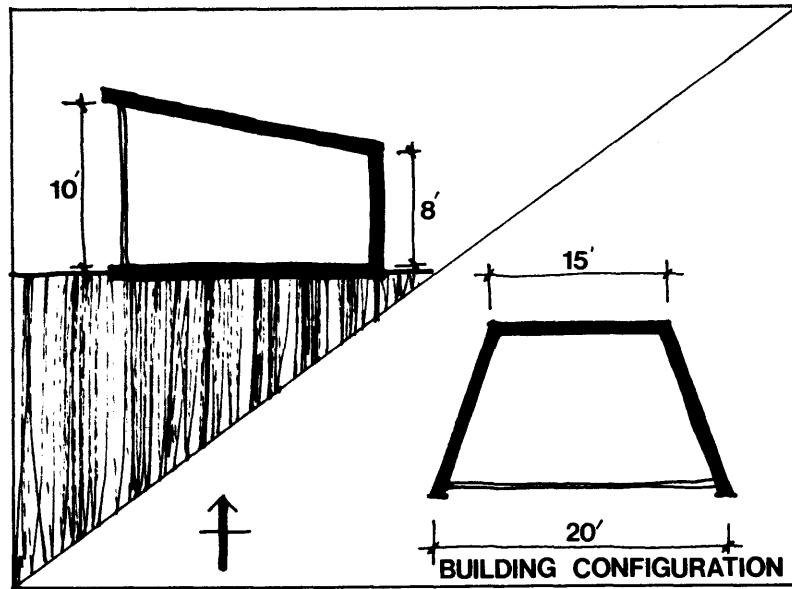
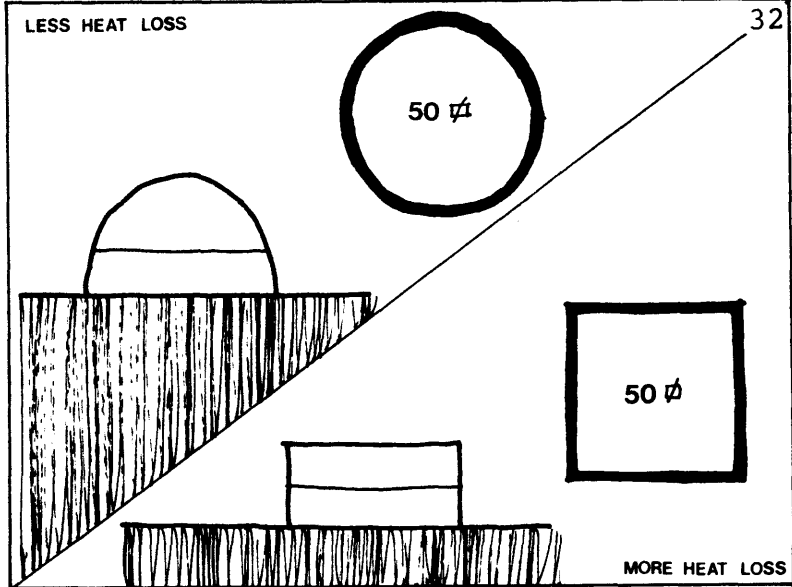



small first floor areas and large overhanging upper floors have increased exposed surfaces. Parking garages located on intermediate levels also increase energy consumption due to the additional exposed surfaces.

J. Zig-zag configurations of east and west walls provide self-shading from summer solar loads, natural wind breaks, and allow winter sun to penetrate the building if windows are oriented south.

#### 4) Building Envelope

The building envelope consists of solid walls, windows, doors, and other openings, roofs, and floor surfaces that are affected by climate and orientation. The envelope directly influences the heating and cooling loads of the building.

In a cold climate, a building should be designed to absorb and to retain as much solar heat as possible. The thermal properties of the envelope are determined by the combination of wall mass, thermal resistance, insulation location, exterior surface color and texture, and the glazing type and location. Energy conserved in the building's structural system is a function of the type and amount of materials used, and the energy required for their production and transportation.

guidelines:

A. Large mass gives high thermal inertia which retards heat flow in and out of the building envelope. Thermal mass can be added to a building by the use of concrete, masonry, brick, or adobe for walls, floors, structural members,

interior partitions and fireplaces.

B. Bearing walls of relatively large mass can provide structural support and building enclosure, as well as thermal mass.

C. Large mass gives high thermal inertia which modifies the effort of a U value on heat transmission by expanding the time scale. A wall of high thermal inertia, subjected to solar radiation, will absorb the heat at its outside surface but transfer it to the building interior over a time period of 6-12 hours. A wall having the same U value, but low thermal inertia will transfer the heat more quickly, perhaps in two hours.

D. Masonry or concrete wall thickness of more than 8 inches has little effect

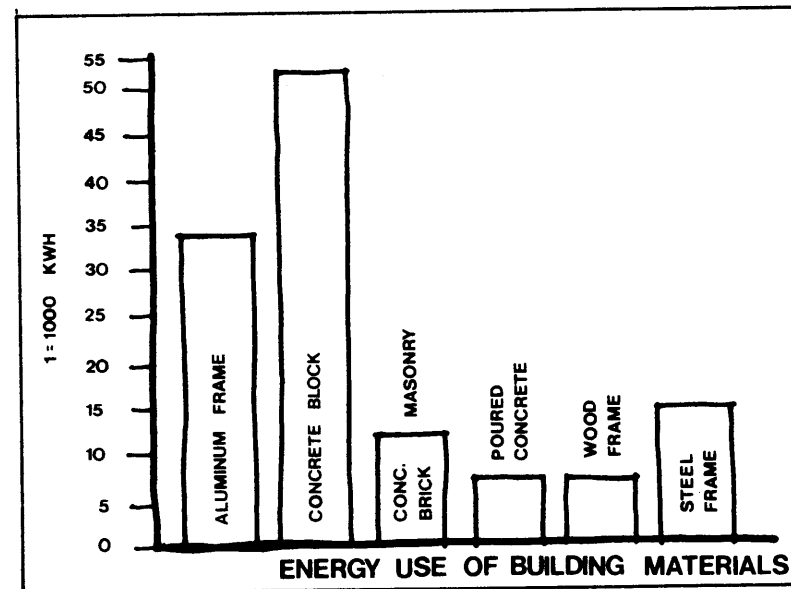
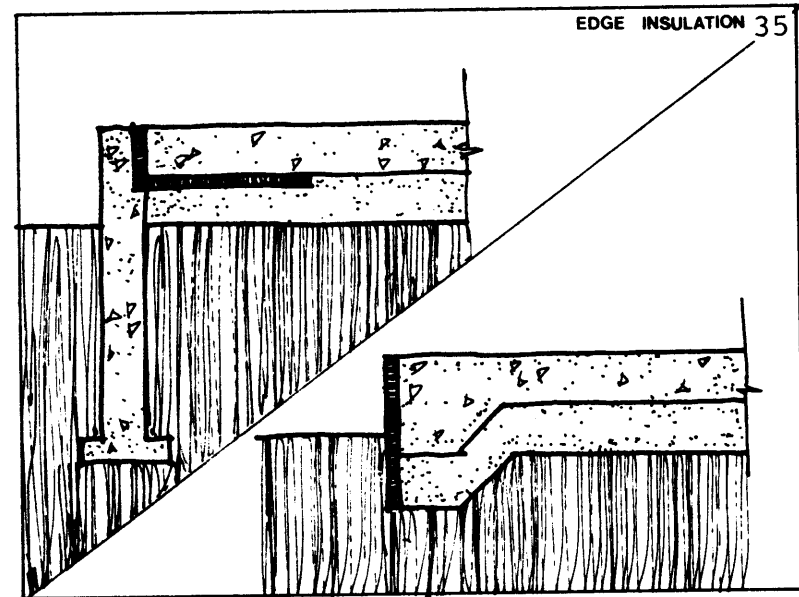

on daily thermal storage, but will increase storage capacity for longer periods of time.

- E. Buildings constructed of a skeleton frame and a skin or curtain wall are generally thin and do not have thermal mass.
- F. Energy consumption could be reduced by using construction materials that consume less energy to manufacture than other materials. Poured concrete consumes one-fifth the energy of aluminum frame.
- G. The location of insulation in a wall section has an effect upon heat transmissions of the building envelope. Insulation efficiency is dependent upon location, amount, and wall factors such as mass, absorptivity, colors,

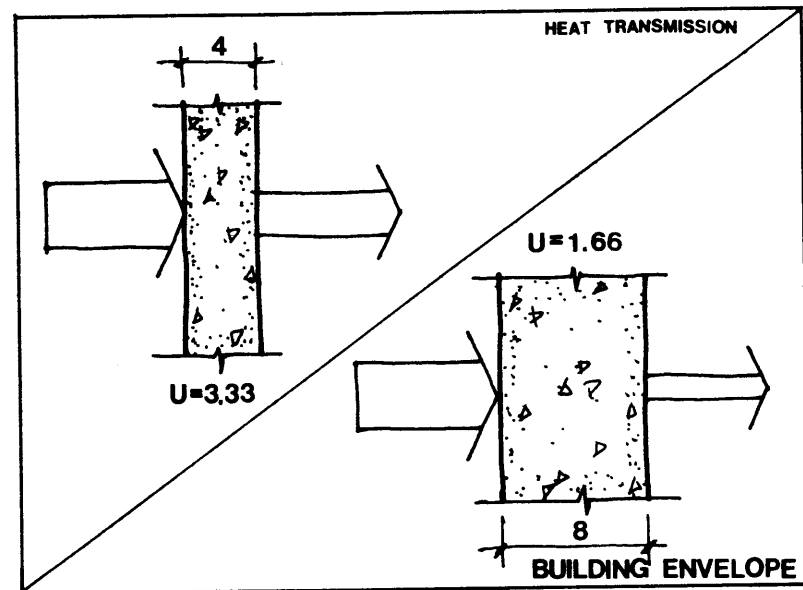
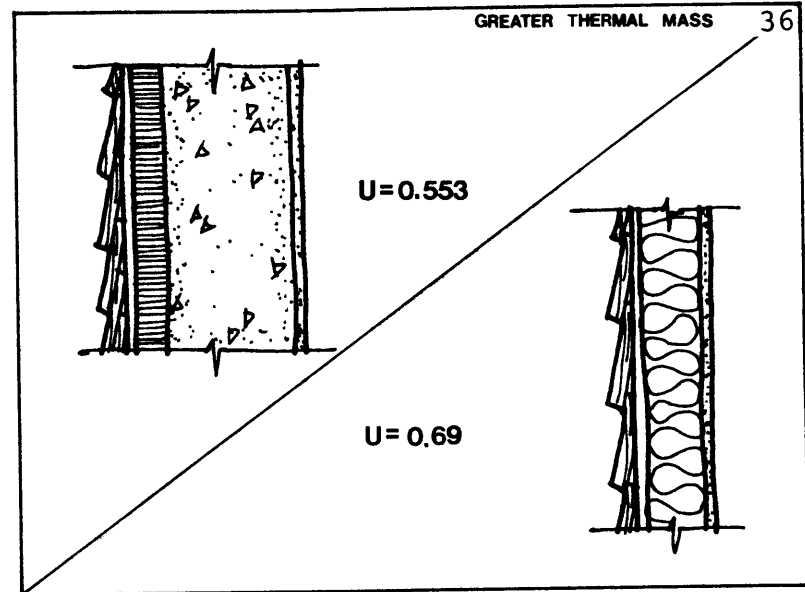

and U value. The location can affect the building's thermal storage capacity. It is especially important in heavy construction and less important in construction of low mass, such as curtain walls.

- H. Insulation should be located on the outside of a wall section or on the outside of the structural system to reduce air leakage through construction joints. All exterior walls and roofs should be insulated.
- I. There is little energy savings in insulation of a floor slab except at the perimeter, or edge of a slab on grade. Edge insulation should also be used in upper floors, as well as ground floors to reduce heat losses.
- J. Insulation should be used in floors

over unheated parking garages.

- K. On surfaces, light colors decrease and dark colors increase solar heat gain. A dark-colored north wall and a light-colored east and west wall will be the most energy conserving.
- L. The color of the exterior wall has little effect on energy consumption of walls of low U values and high thermal mass.

#### 5) Glazing Type and Location

Windows are significant contributors to heat loss in the winter time and are instrumental in allowing heat gain at all times of the year. They have a major effect on building energy use due to transmission, solar gain and air infiltration. The extent, type, and location of glazing determine the amount of natural light

available, the amount of required solar and glare control, and the heating and cooling capacities necessary to compensate for the heat losses and gains in the glazed areas.

guidelines:

A. Size and placement are the most important characteristics of glazing. The location of glazed areas is dependent on interior space usage, and desirable external views. Large windows will provide more natural illumination, but will require a thermal barrier installed over the windows at night to reduce heat loss. Large glass areas could also cause discomfort to inhabitants if there is no control for solar heat, radiation, glare, and cold down-drafts.

B. In cool and temperate regions, large glazed areas on northern exposures produce significant heat losses. Glazed areas should be small to control the winter heat losses.

C. Reducing the glass area on the east and west facades will reduce the heat gain and loss.

D. The total energy entering through a window may be ten times greater than through an equal area of conventional wall, but the heat loss will be 18 times higher.

E. Double- or triple-paned glass will reduce thermal transmission in the following descending order of efficiency: triple glazing (with 1/2 inch air space), triple glazing (with 1/4 inch air space), insulating glass, double

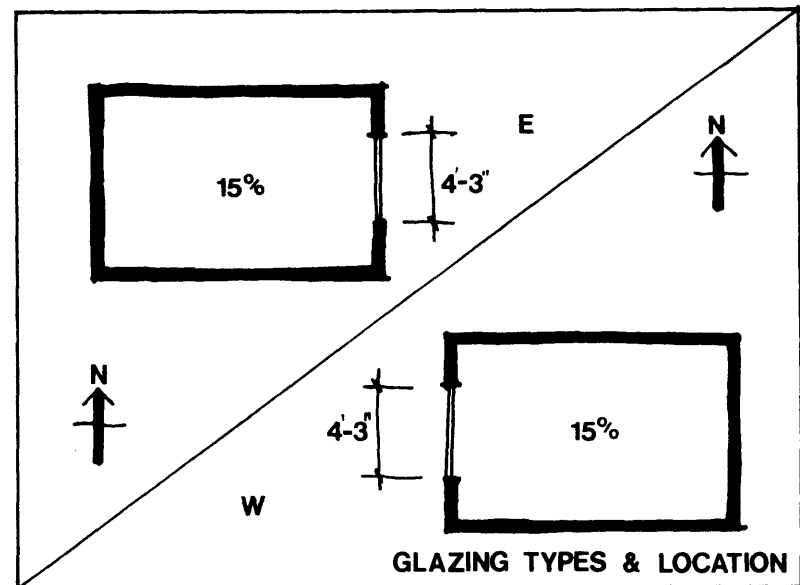
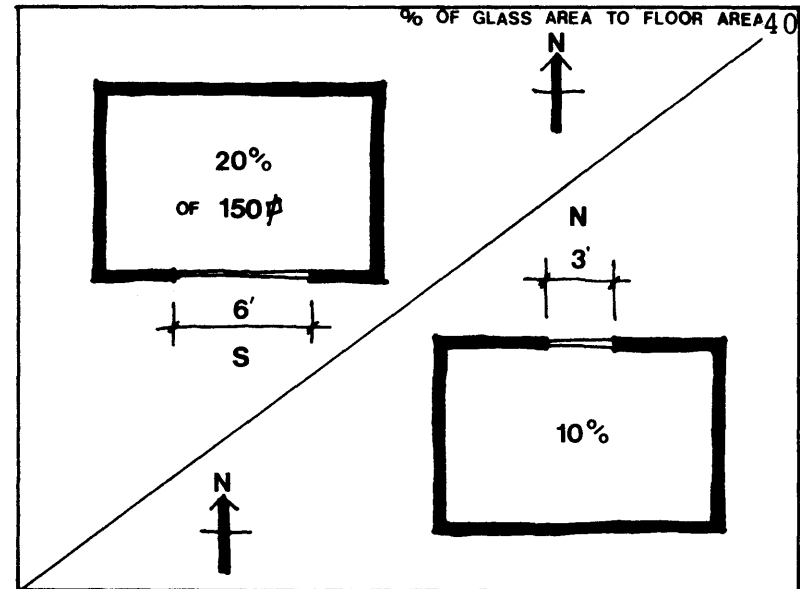



glazing (with 1/2 inch air space), double glazing, and single glazing.

F. Double glazing is desirable on all window types: solar windows, louvered solar windows, louvered skylights, and terrarium solar windows.

G. In cool and temperate regions, northern windows should be double or triple glazed. Windows on other orientations should allow maximum winter solar penetration, while reducing heat losses.

H. Reflecting and heat-absorbing glass should only be considered for south orientations. In winter, this glass could result in a loss of useful heat, because 45% of the solar energy is absorbed.

I. Reflecting and heat absorbing glass is unnecessary on north, northeast, and

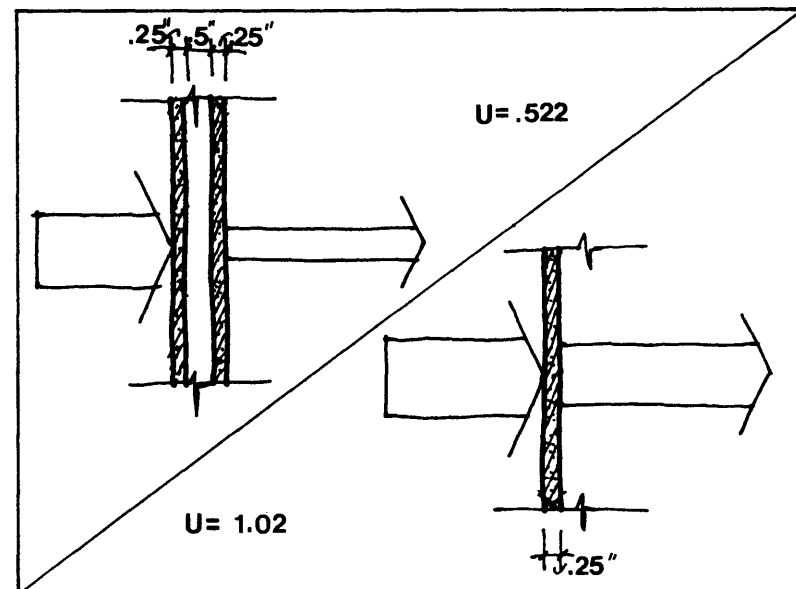
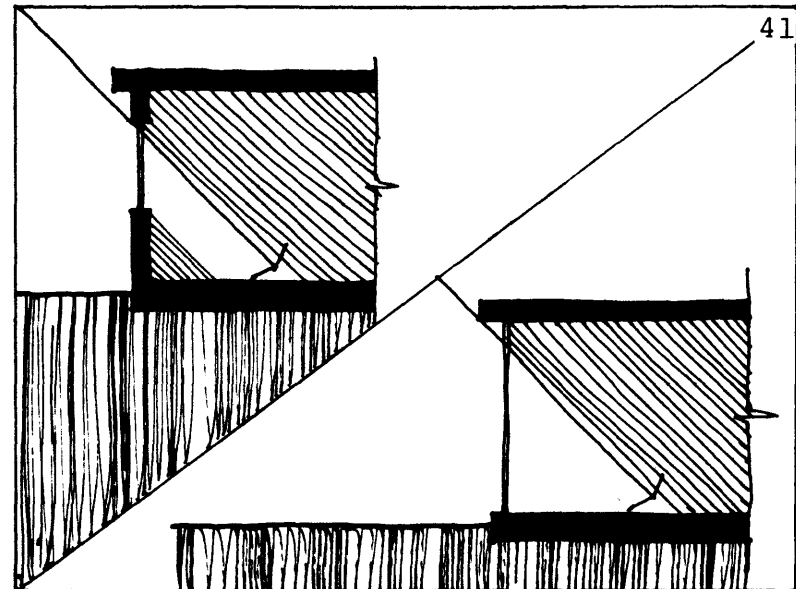

northwest orientations.

- J. The amount of glazing on each orientation will influence a building's overall energy usage. Most codes require a minimum glazed area of 10% of the floor area. For passive solar collection, south-facing glass should total 1/3 to 1/4 of the floor area in cold climates, and 1/4 to 1/5 of the floor area in temperate climates.
- K. For areas adjacent to east and west walls, the amount of glazing on each wall should be 15% of the floor area. For areas adjacent to north walls, the window opening should equal 10% of the floor area.
- L. Window configuration can be important in energy savings. A round window shape will reduce infiltration loss

through the cracks around windows, while maintaining exterior light, view and ventilation.

- M. If windows are operable, pop-out designs can limit infiltration or air leakage. Next efficient are hinge-type windows.
- N. Skylights can be used to bring sunlight into interior spaces, but should be covered with a thermal barrier at night to lessen heat losses.
- O. Wood window frames account for 13% of a window's thermal losses, while aluminum window frame contribute 25% of the loss.

#### 6) Sunshading Devices

Thermal barriers are needed on windows to prevent excessive heat loss in cold weather and maintain interior temp-

eratures at night. Both internal and external shading devices can be used. External shading devices prevent solar gains from entering a building, and can be incorporated into the initial building design. Internal shades, which are less expensive and easier to install, can also minimize solar gains.

guidelines:

- A. During the winter, insulated shutters, used on windows on east facades in the afternoon, west facades in the morning and on north facades most of the day would reduce heat losses through the glazing. At night, the shutters would be required on all exposures to achieve a total heat loss savings of 28%.
- B. Other methods of minimizing heat loss

would be through the use of variable thermal barriers such as thermal curtains, beadwalls (styrofoam beads blown between two panes of glass), and insulated internal rotating louvers over skylights or large windows.

- C. Solar screens used in windy areas can act as wind breaks, thereby lessening infiltration through window cracks.
- D. Internal shading can decrease solar transmission through glazed areas on all facades. Examples of internal shading are closed draperies, venetian blinds, vertical baffles, and movable insulated shutters of thick foam. To reflect light, and heat away from the interior, the shutters should be light in color, while dark colors would tend to absorb light and heat.

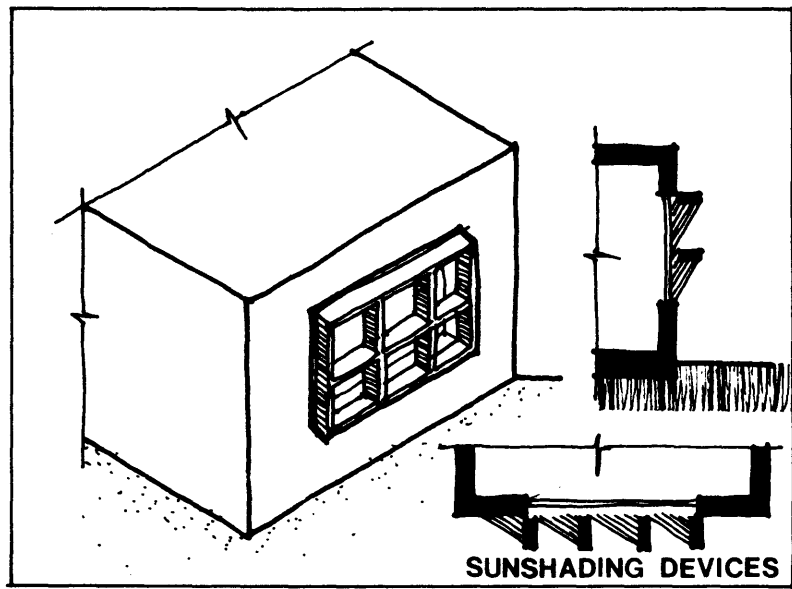
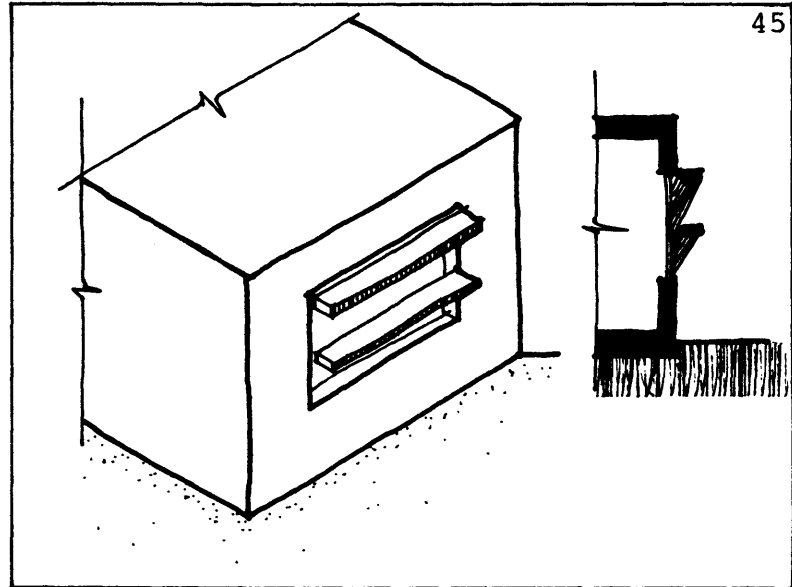

E. Internal shading can effectively decrease solar transmission into a building's interior. In descending efficiency are: white, opaque roller shades, light translucent shades, light-colored venetian blinds, dark opaque roller shades, and medium-colored venetian blinds.

F. Exterior solar control must be designed specifically for each facade since time and duration of solar radiation varies on each exposure. On southern exposures, horizontal shading is the most effective for control of heat build-up resulting from the summer sun. Examples of horizontal shading are roof overhangs, fixed solar fins, louvers, and cloth and metal awnings. Roof overhangs on low buildings can

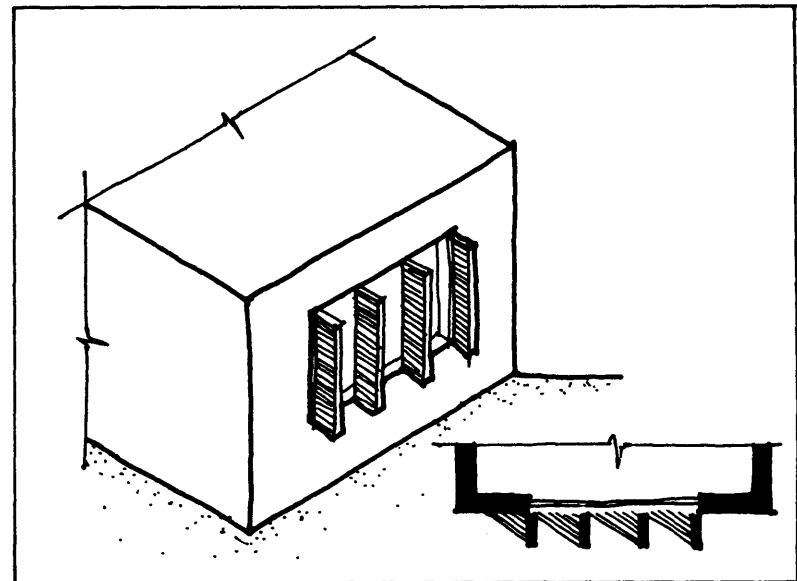
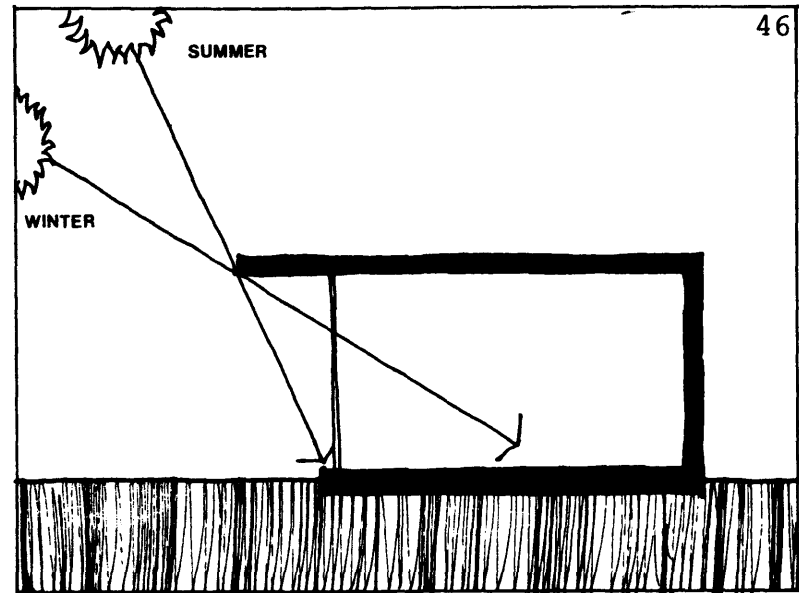

keep the high altitude summer sun out of a building, while allowing the lower altitude winter sun in. In taller buildings, upper floors can be designed to overhang and shade lower floors.

G. Instead of a large overhang, horizontal louvers can be equally effective in sunshading.

H. On east and west orientations, a combination of vertical and horizontal sun baffles are required for sun control in the summer. Overhangs are ineffective on these exposures. Vertical louvers should be adjustable and separate from the building and should not shade during the winter. Air should be allowed to circulate between the building and louver.

I. Movable external shades, such as win-

dow shutters can eliminate peak summer heat loads and still allow penetration of rays during winter.

K. An eggcrate sunshade design is a combination of both horizontal and vertical sunscreens and is more effective than vertical or horizontal louvers. It is useful on all exposures and should be separate from the building for air circulation and elimination of heat transfer.

#### 7) Space Planning

The building plan can have a major effect on the energy required to maintain comfort conditions in both winter and summer. The plan and building configuration influence each other, and affect thermal conditioning, light, and air.



guidelines:

- A. In northern climates, corridors, equipment spaces, toilet rooms, and other service areas should be located on the north walls to act as buffer zones against the cold.
- B. Heat generating functions should be placed adjacent to exterior surfaces to permit the dissipation of excess heat, and to balance the heat loss and gain in a structure.
- C. Stacking toilets and kitchens will lessen the amount of energy needed for exhaust systems and their infiltration.
- D. Closets located on the exterior wall will add to the insulating value of the wall.
- E. Enclosed entries can act as buffers and air locks to increase insulation

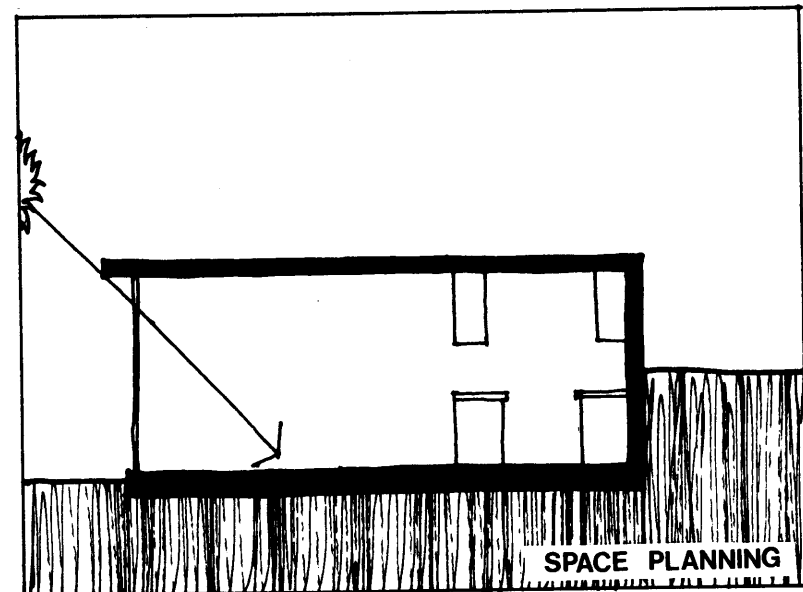
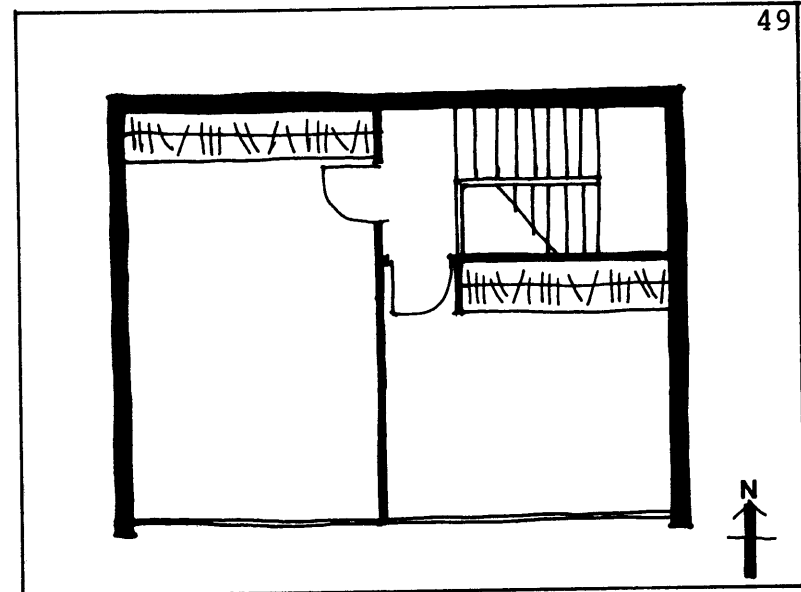

against outdoor conditions. The entry can be designed either within the perimeter of the building or added to it. It should be large enough so that both doors do not open at the same time.

- F. Reducing the number of exits and entries will reduce the energy losses through the building envelope.
- G. Parking garages can conserve energy if they are placed under a building or below grade.
- H. A maximum amount of living space should be located so that it has south exposure.
- I. Elements such as wall partitions, ceilings, floors, furniture, and fireplaces can increase the heat storage mass of the structure by the use of heavyweight materials.

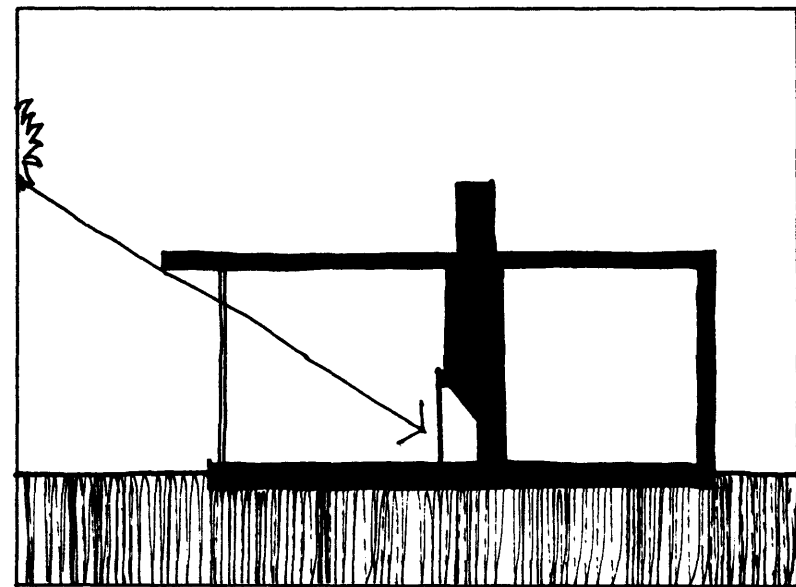
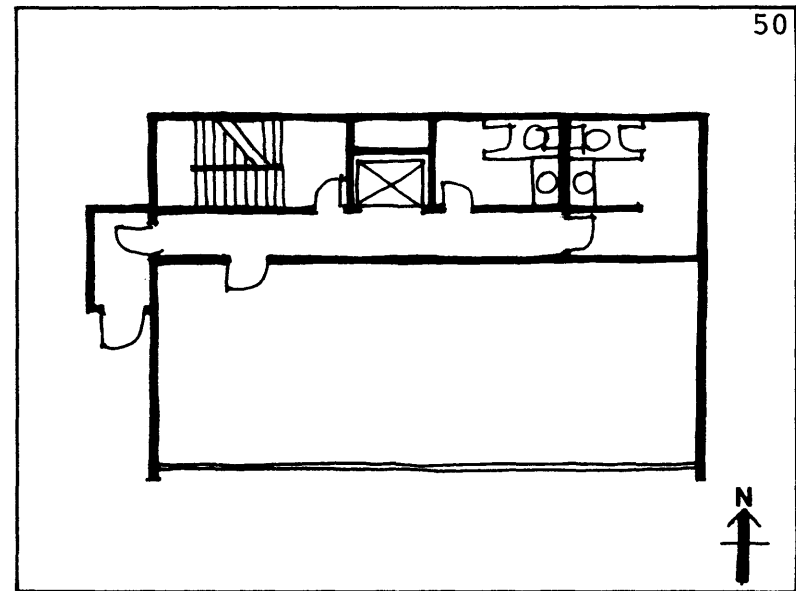

- J. Greater ceiling heights increase heat transmission through the building envelope by the increase of the perimeter area.
- K. If skylights are used, the floor to ceiling height should be minimized for maximum lighting benefit.
- L. Light-colored walls, floors, and ceilings increase reflectance more than dark colors, resulting in better use of light.

#### 8) Ventilation

The amount of ventilation a building requires is dependent on user needs and requirements. Fresh air quantity, circulation, and exhaust needed will affect the energy consumption of the building.

guidelines:

- A. Flow-through natural ventilation which

will provide cooling in the summer, is dependent upon the building site, orientation, and climate.

- B. Natural ventilation is provided by operable windows and doors. For optimum movement, air should enter at a lower height than the height that it exits so that it picks up heat from the interior of the room and as it rises, it exits quickly.
- C. The leeward side of a building should have larger openings than the windward side to increase wind velocity.
- D. Air flow can be directed up, down, or sideways to any part of the room by using louvers at the building opening.
- E. Windows sills should be located at the height where ventilation is desired.
- F. For a sloped site, breezes moving up

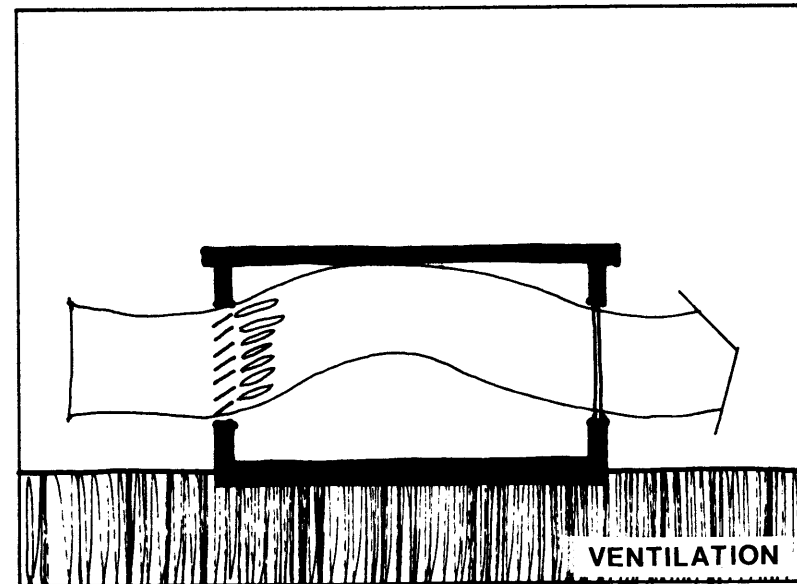
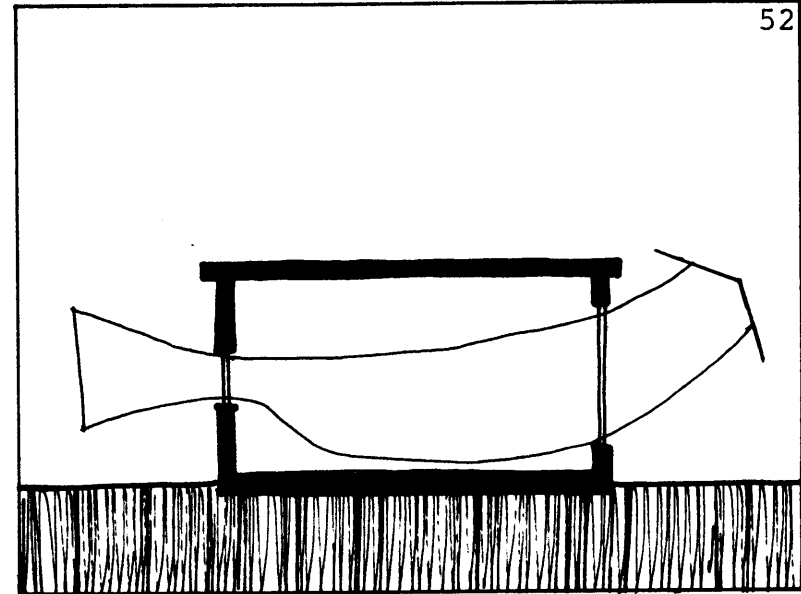

- the hill during the day and down at night should be maximized to increase natural ventilation. Near bodies of water, breezes move from water to land by day and from land to water at night.
- G. The velocity of ventilating currents can be increased by using walls extending from the exterior wall to create small pressure zones in front of the windows on the same facade. Casement windows, or operable shutters, extended perpendicularly to the wall can serve the same function.
- H. By reducing the amount of exhausted air from the building, the amount of ventilation needed is lessened which decreases heat losses.

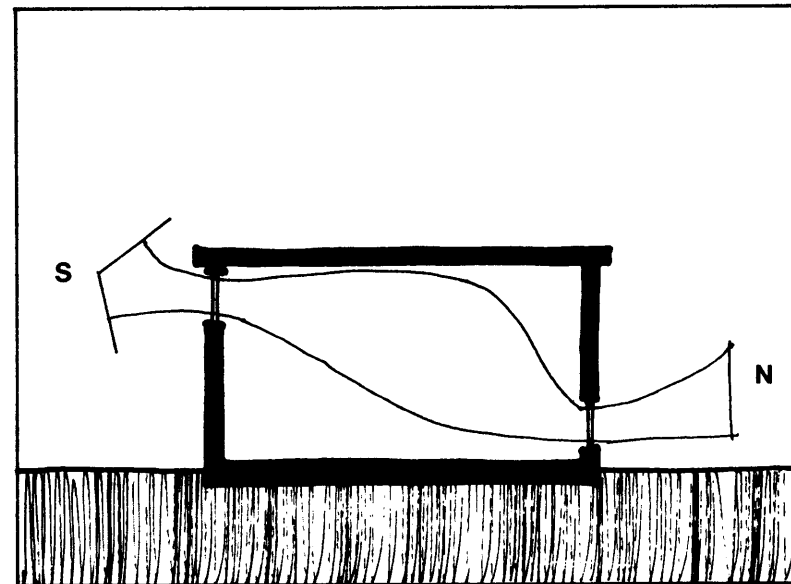
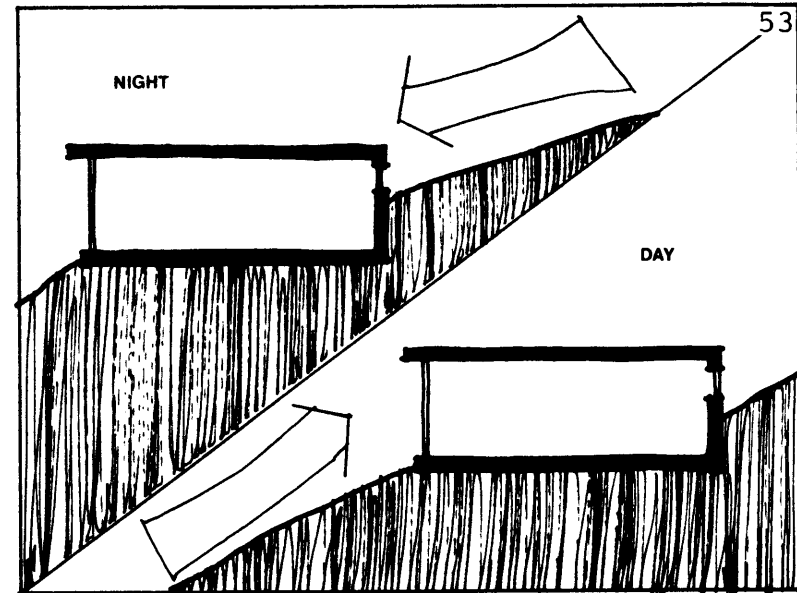

### III. Review of Passive Solar Design

#### Concepts

Within the context of energy conscious design, passive solar concepts utilize the sun by direct, indirect, and isolated methods, while energy conservation concepts primarily deal with direct solar gain. While it is impossible to show a distinction between energy conservation and passive solar usage in direct use of the sun, indirect and isolated solar gain methods use special building elements to collect, store, and radiate energy.

Passive systems have few complex moving parts or controls. Human control is important in this system to provide comfort. This type of system as opposed to an active solar system, expresses a

functional approach to architecture that conceives of the heating and cooling system as an intrinsic part of a building. The underlying concept is: sun-mass-space. The operation of a passive system is the control of the natural energy flow. A passive solar system reflects an understanding and use of climate with building design and construction.

Indirect solar gain uses the fabric of the structure to collect and store solar heat, but the solar energy does not penetrate to the building's interior. The energy is intercepted and absorbed by a heat storage mass that is placed between sun and living space. Materials are simple, with little or no electric power used for heat distribution. Natural convection or thermal radiation moves the

solar heat from storage volumes to the living areas. The storage medium can be waterbags, water walls, metal, glass, or plastic containers, and concrete, brick, or stone walls. Storage location can be in the roof, between floor and ceiling space and in south-facing walls. In the indirect gain method, there are three basic techniques:

- 1) mass trombe wall
- 2) water trombe wall
- 3) roof pond

#### 1) Mass Trombe Wall

This is a system of indirect gain that allows solar radiation to pass through glazing onto a storage mass of concrete, adobe, stone, or composite of brick, sand or block. The storage mass radiates the collected heat to the inter-

ior space after a time lag that is dependent on the storage mass material. Heated air in the space between the glazing and the mass trombe wall can be vented to the interior space by controllable vents in the mass. This allows for regulation of heat to the living space. The surface of the south-facing storage mass is black painted and should be separated from the exterior environment by double glazing to reduce heat losses. Concrete as a structural and heat storage material, has high thermal capacity, which results in a heat lag of 6-12 hours. To store sufficient heat, 150 pounds of masonry should be provided for each square foot of south-facing glass.

#### 2) Water Trombe Wall

The water trombe wall works with the

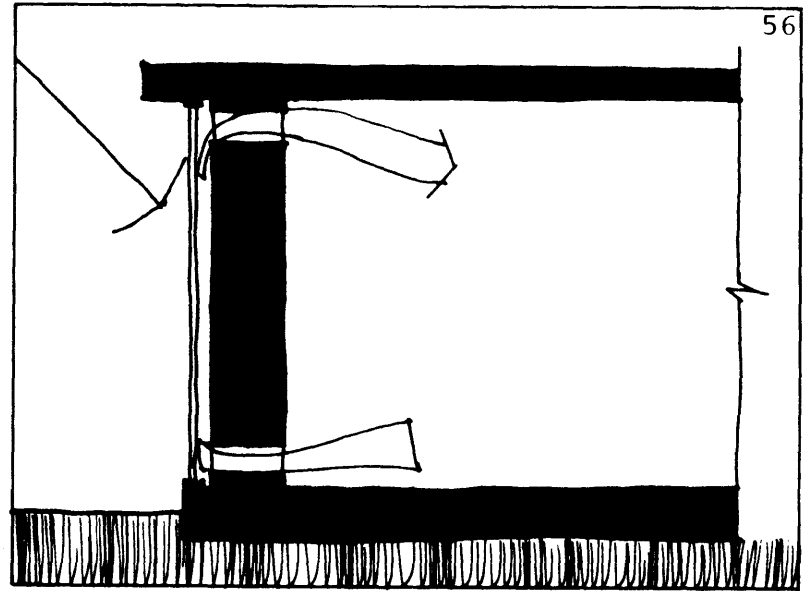
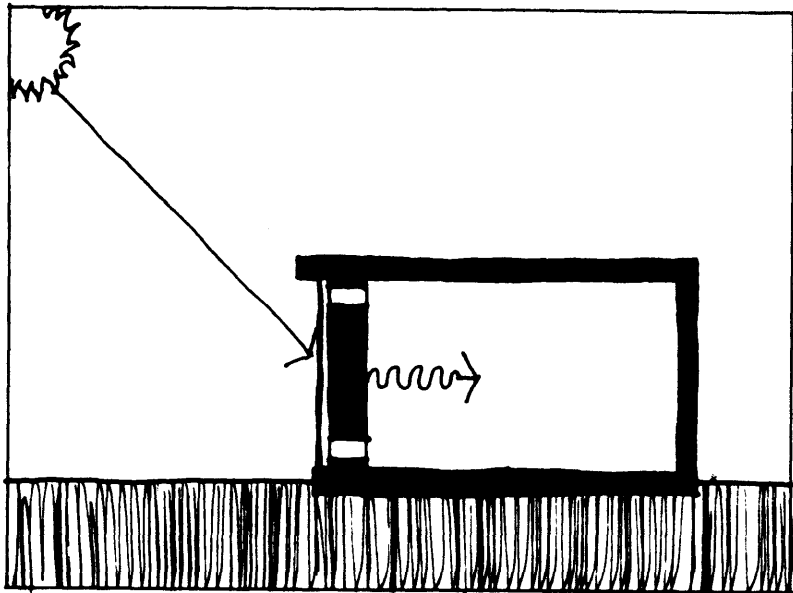

56

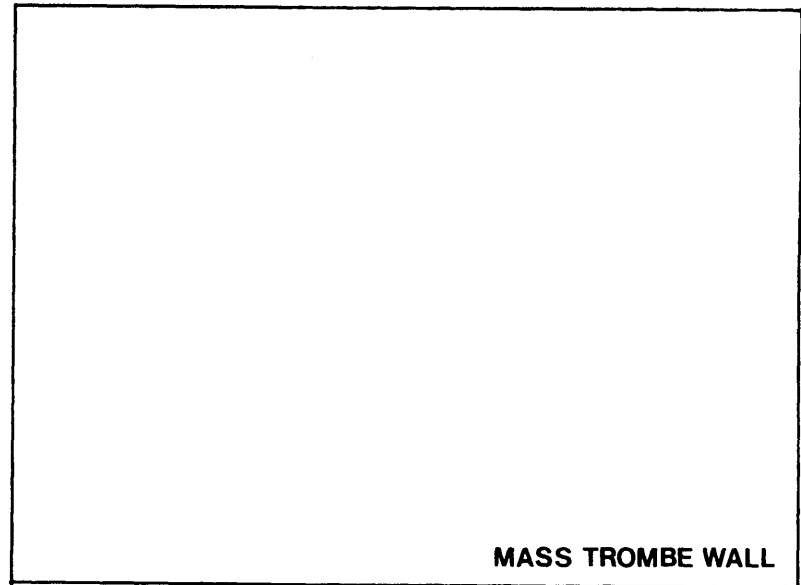
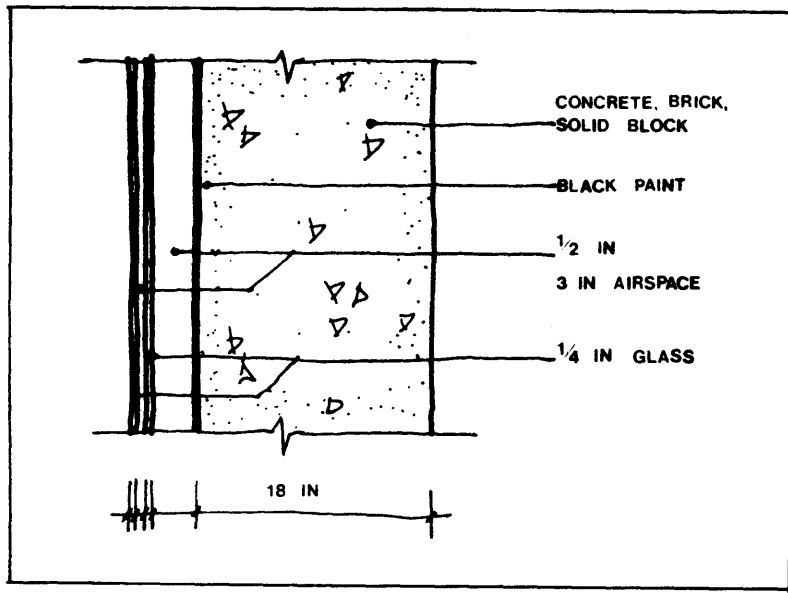



same concept as the mass trombe wall. The solid mass is replaced by a liquid storage mass. With water as the storage medium, thermal transfer is rapid, allowing for almost immediate radiant distribution to the interior space. The storage capacity is determined by the size and shape of the storage containers, which can be tin cans, bottles, tubes, oil drum barrels, bags, and solid water walls. The surfaces of the containers are painted black and are separated from the south-facing glazing by an air space. An insulated shutter should be used over the glazing to reduce heat losses at night. For each square foot of south-facing glass, 30 pounds of water should be provided to store a sufficient amount of heat.

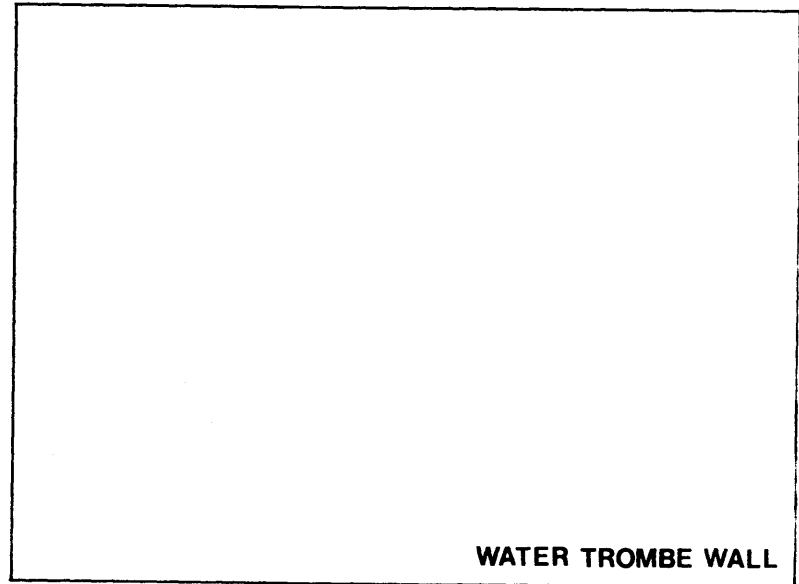
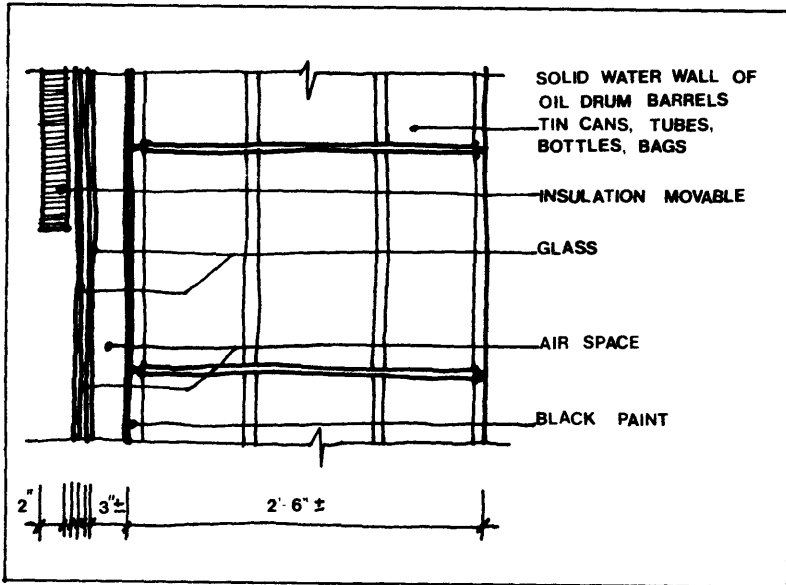
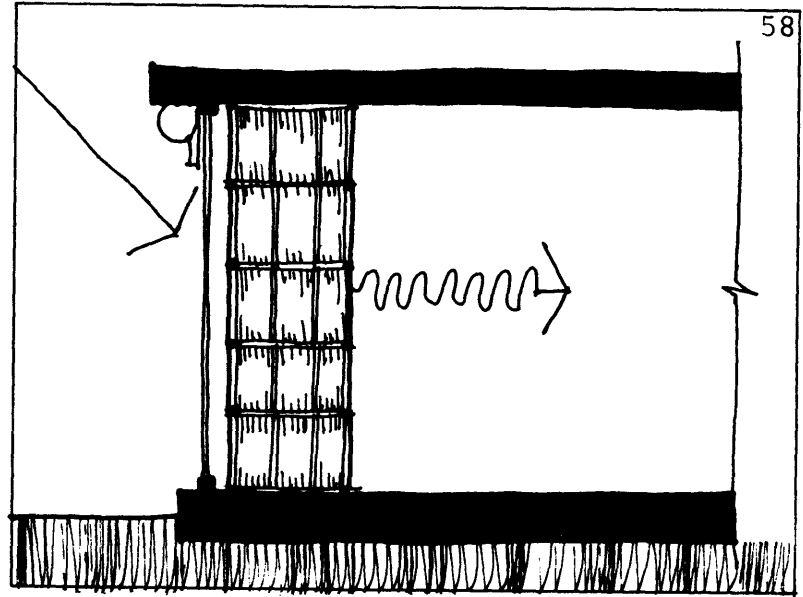
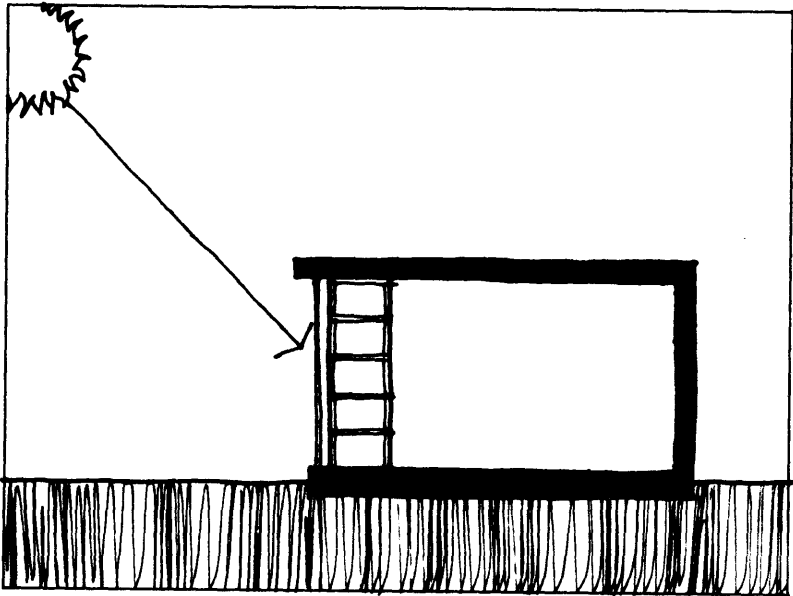

**WATER TROMBE WALL**

### 3) Roof Pond

The indirect solar heat gain system of the roof pond uses the water trombe wall concept in the roof. The roof becomes a solar water collector and storage mass that absorbs and stores solar radiation, and then radiates it to the building below. In the winter, the roof pond is covered with exterior movable insulation at night to prevent heat loss. In the summer, the use of the insulation prohibits heat gain during the day. With the roof pond exposed at night, the heat is radiated from the house to the exterior to provide cooling. The roof pond is composed of a flat roof structure of sheet metal decking that supports black plastic bags or shallow pans each 8 inches deep. This structure is supported by con-

crete walls or a massive wood structure. Roof ponds are most feasible in warm climates for cooling purposes.

Isolated solar gain methods are special building elements that are similar to direct gain energy conservation concepts and the passive solar indirect gain methods. This method uses an isolated collector space as part of the building design to generate a new energy flow in the building. The two basic system types are:

- 1) sunspace
- 2) thermosiphon

#### 1) Sunspace

A sunspace is a glazed-in area that traps heat. This space is attached on the south facade of a building but is distinct from the interior space. A thermal

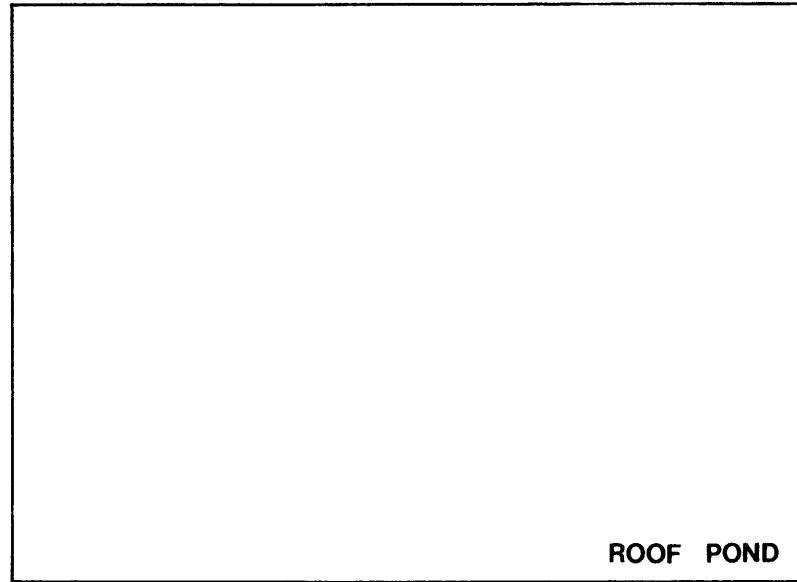
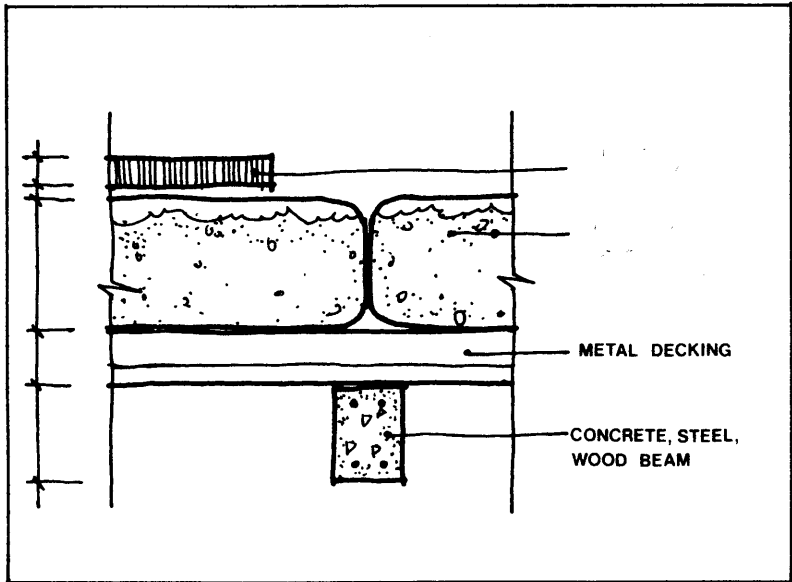
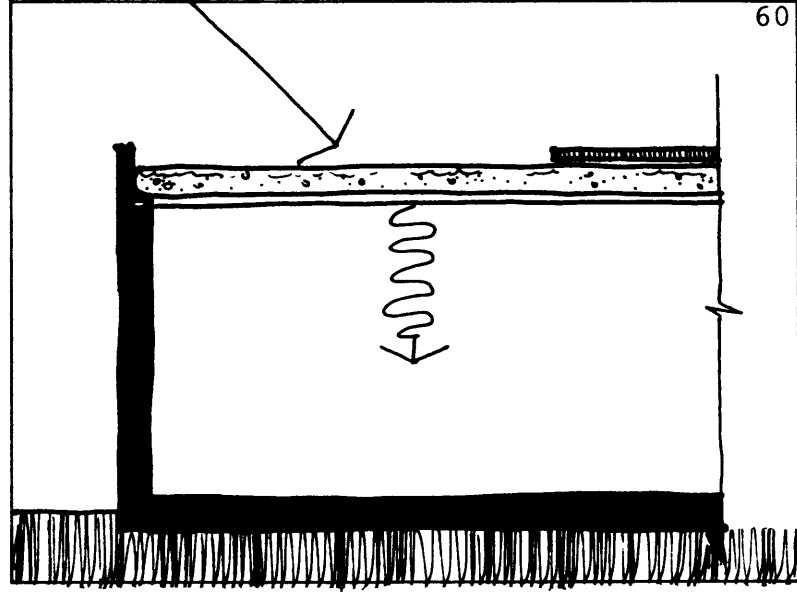
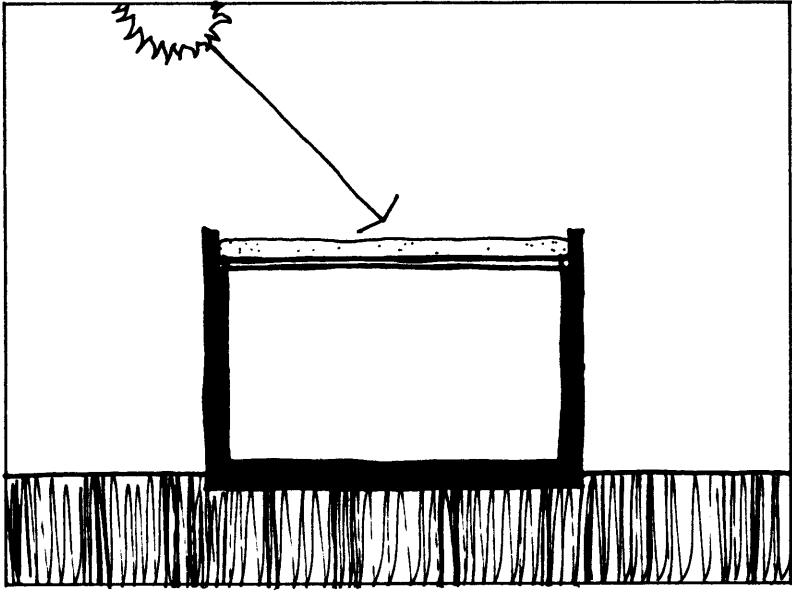

ROOF POND

storage mass in the sunspace stores heat and slowly releases it. Sunspaces can be greenhouses, atriums, sunporches, and sunrooms. The thermal storage mass can be contained in walls, floors, benches, rock beds, and water pools. A greenhouse attached to a structure can effectively raise the temperature outside the building's exterior wall in the winter. In the summer, it can lower the temperature with plants and shading devices. The greenhouse acts as a secondary skin on the facade, hence the wall separating the greenhouse and building must be insulated to control heat flow and to prevent overheating. Wall surfaces in the greenhouse directly exposed to the sun should be dark-colored. Floors should be light-colored to prevent overheating, Heat loss

through the glazing can be prevented by using insulated shutters. The distance from the exterior wall of the greenhouse to another object, such as a tree or building on the landscape, should be at least 2-1/2 times the height of the wall.

Atriums are centrally-located courts that can act as heat traps within a structure, surrounded by enclosed space. The building's exterior glass area would be oriented inward to the atrium to reduce heat losses through and around windows on the exterior of the structure. The atrium's ability to passively collect solar heat would be maximized if it were covered with a skylight and an insulating shutter. The atrium has a strong impact on the heat loss through the building envelope by minimizing exterior openings.

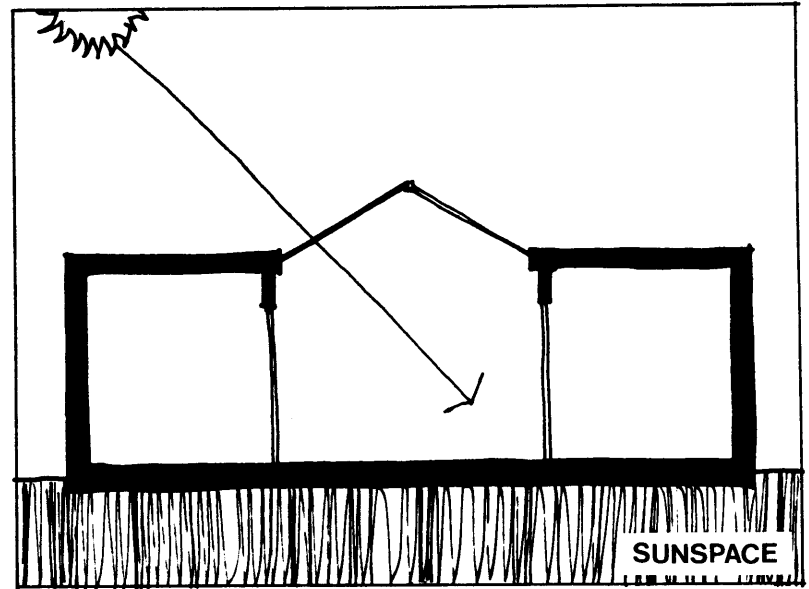
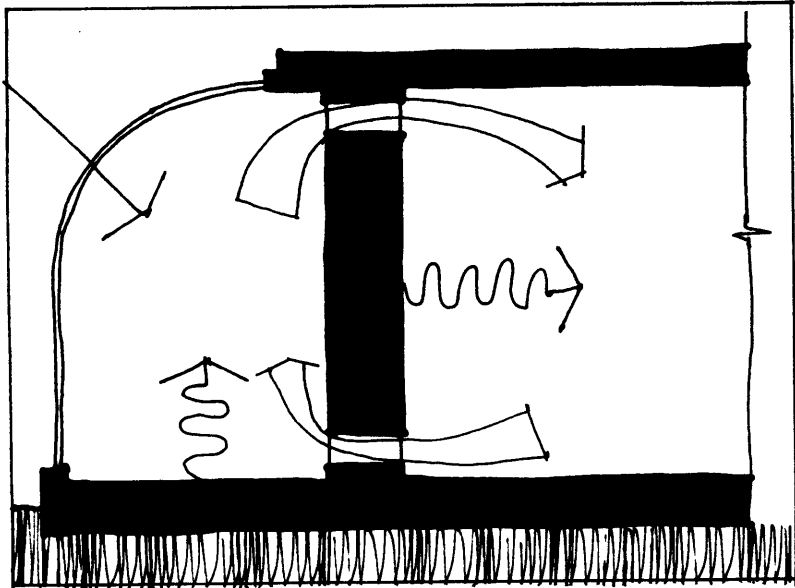
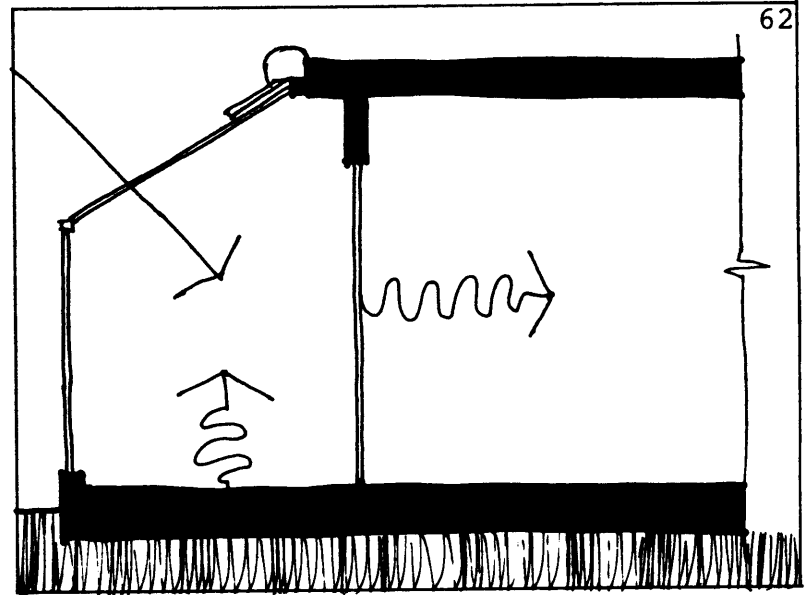
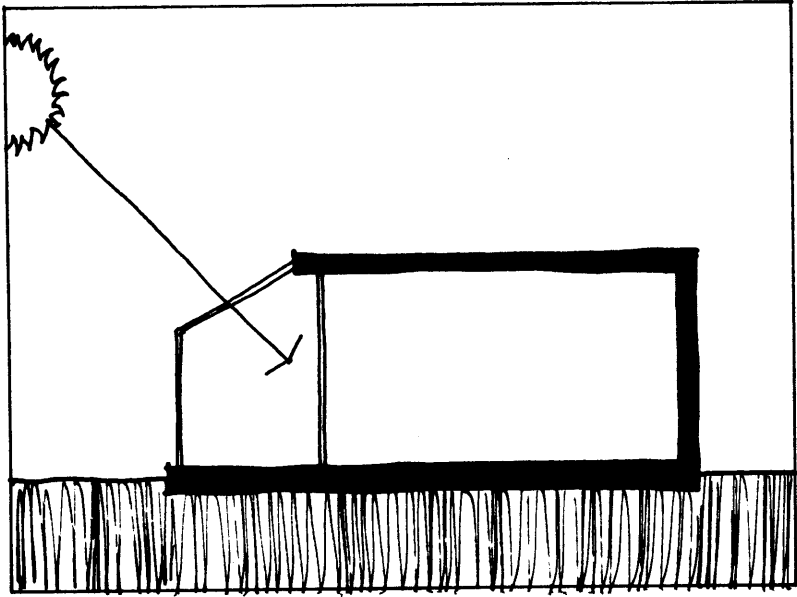

## 2) Thermosiphon

The second isolated gain method is thermosiphon which uses an isolated collector. The thermosiphon is similar to an active solar system. The collector space is separated from the interior space, and its heat exchange is dependent on air circulation. This system is based on the heat flow that occurs when cooling air falls to a point below the solar collector and is then heated there by solar energy. The heated air rises through a storage mass which absorbs the heat and radiates it to the living space. Once cooled, the air falls back to the collector to repeat the cycle. The thermosiphon system is adaptable for both domestic water and space heating, and operates on natural convection, hence it requires no

external power, fans, or blowers to complete the cycle.

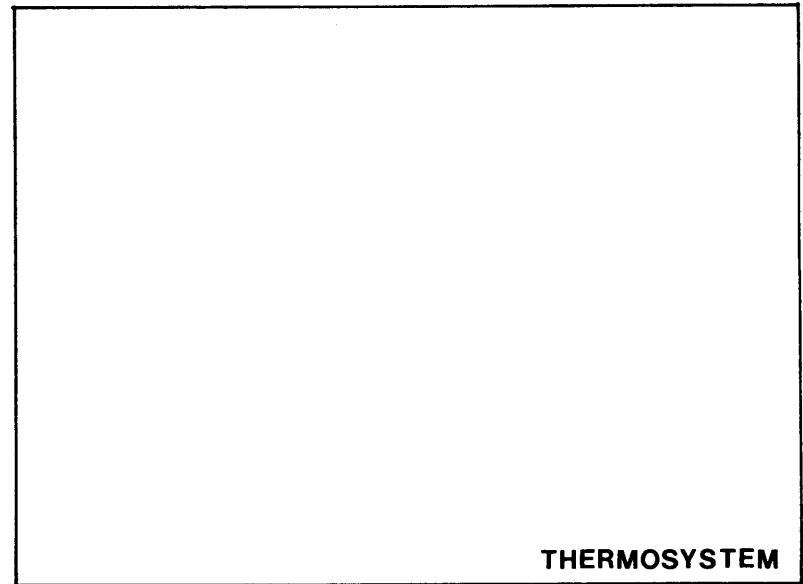
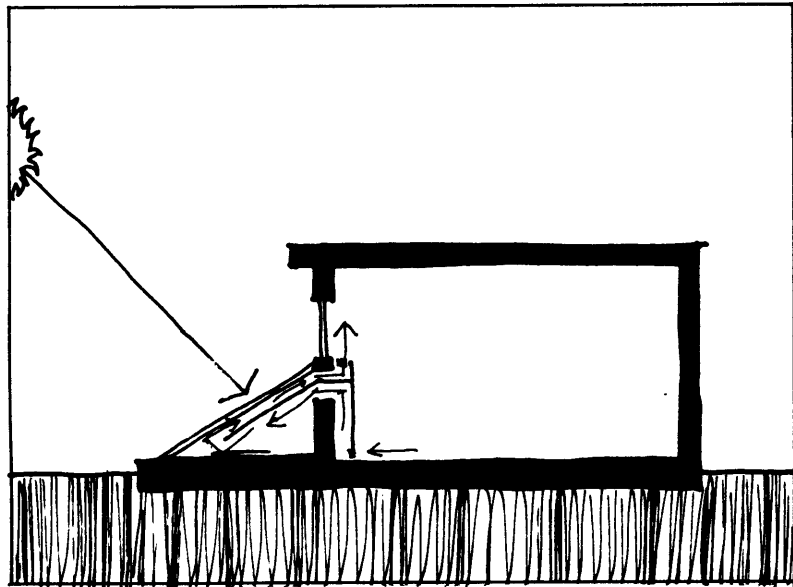
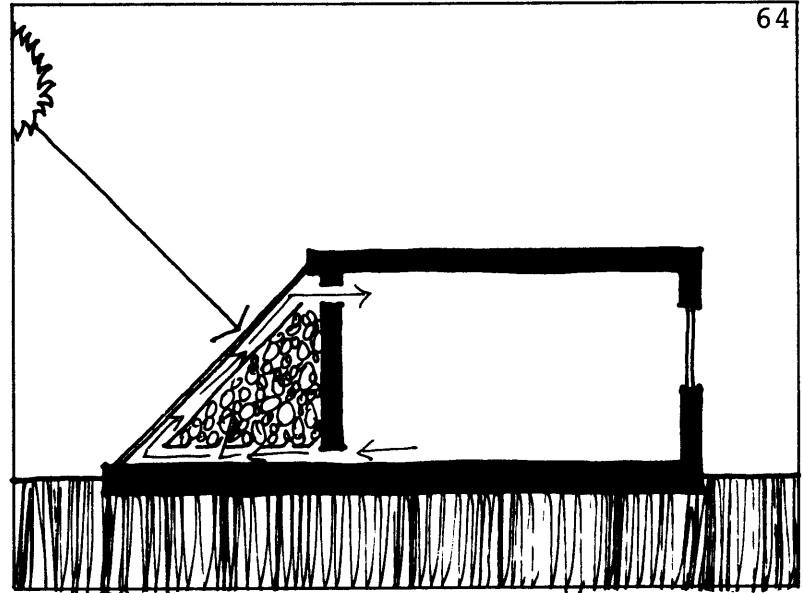
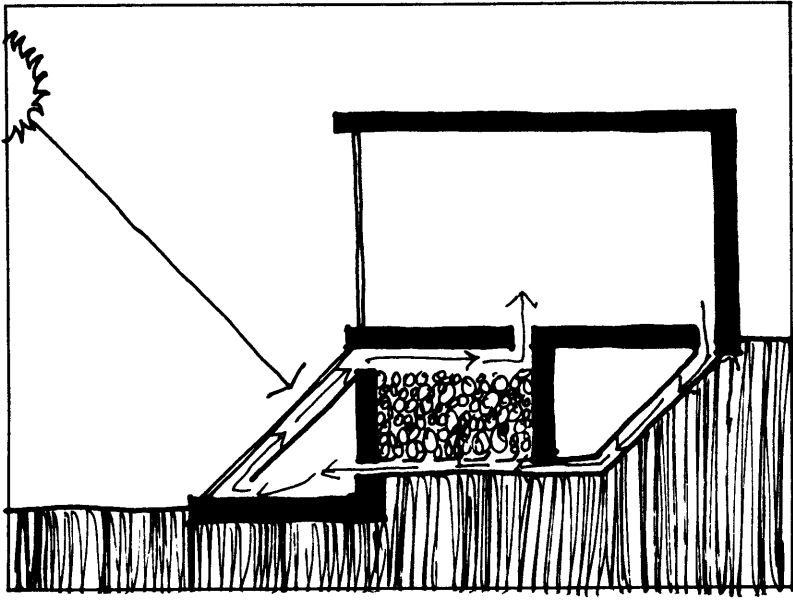



**PROPOSED METHOD**

## PROPOSED METHOD

### I. Energy Efficient Industrialized Housing in Reinforced Concrete

An energy conscious building results from the use of energy-conserving and passive solar energy devices. The concepts that have been previously described are interrelated and must be used jointly to achieve a reduction in energy. Energy efficiency in a structure is viewed on a complete basis with many individual parts contributing to it. The building is considered as a whole; a system in which there is interaction among all the elements, such as the envelope, configuration, orientation, space planning, and uses.

The notion of the integration of many parts is central to the system of indust-

rialized building. All parts of the building process: planning, design, subsystems, and construction, are conceived and function as a whole. The building is considered in its entirety; as a system dependent upon its parts. A system is based on industrialized components that allow flexibility in planning, application to different sizes of buildings, spacial morphology, and site topography. This assembly of building components which can be permanent or temporary, respond to laws of organization, of behavior, and of construction based on qualitative programs to achieve flexibility in use, in site, change, and growth. A system adapts itself to multiple sizes, functions, sites, and codes.

In industrialization, the building or

design constants are the laws of organization, behavior, and construction. The laws of organization concern the physical relation of units, circulation, and hierarchies between parts. The law of construction involves the behavior of materials and construction methods, while the law of behavior is related to the way the system responds to human needs.

Industrialization, therefore, is rationalized building that is a tool to be used in design and construction. The conceptual framework is rationalism, functionalism, science, technology, and change.

The essential features of industrialized building are the mechanization of labor, rhythm of production (represented by continuity and evenness of output), and mass production. Labor is divided

into separate, distinct phases that facilitate the demarcation of labor and trade specialization. Industrialized building is considered to be the opposite of traditional building. Traditional building describes methods characterized by a prolonged cycle of operations with a large outlay of manual labor. Basic operations are carried out on the building site, resulting in a seasonal industry. In comparison, industrialization results in a smaller labor outlay, more efficient use of materials, and a considerable shortening of the construction cycle. Hence, the building industry is much less seasonal.

The ratio of work carried out in the factory to the total construction work is a measure of the level of industrializa-

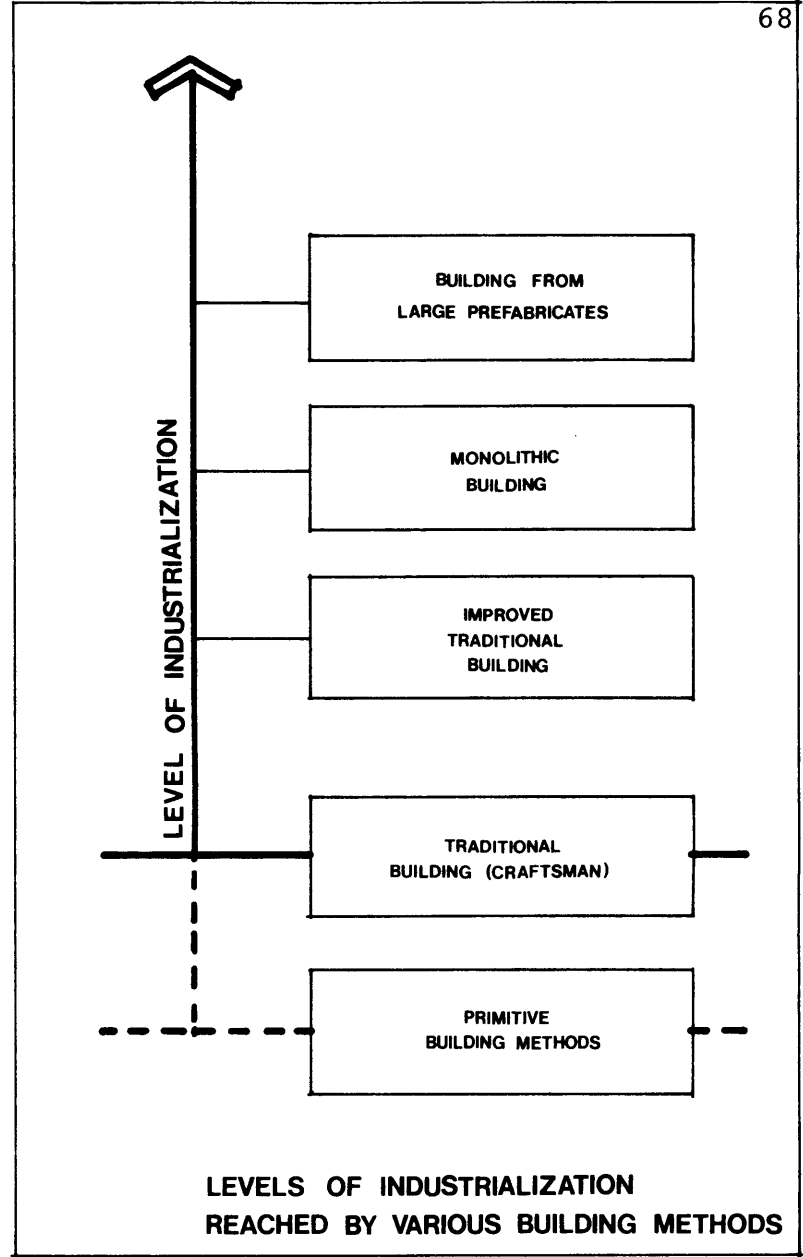
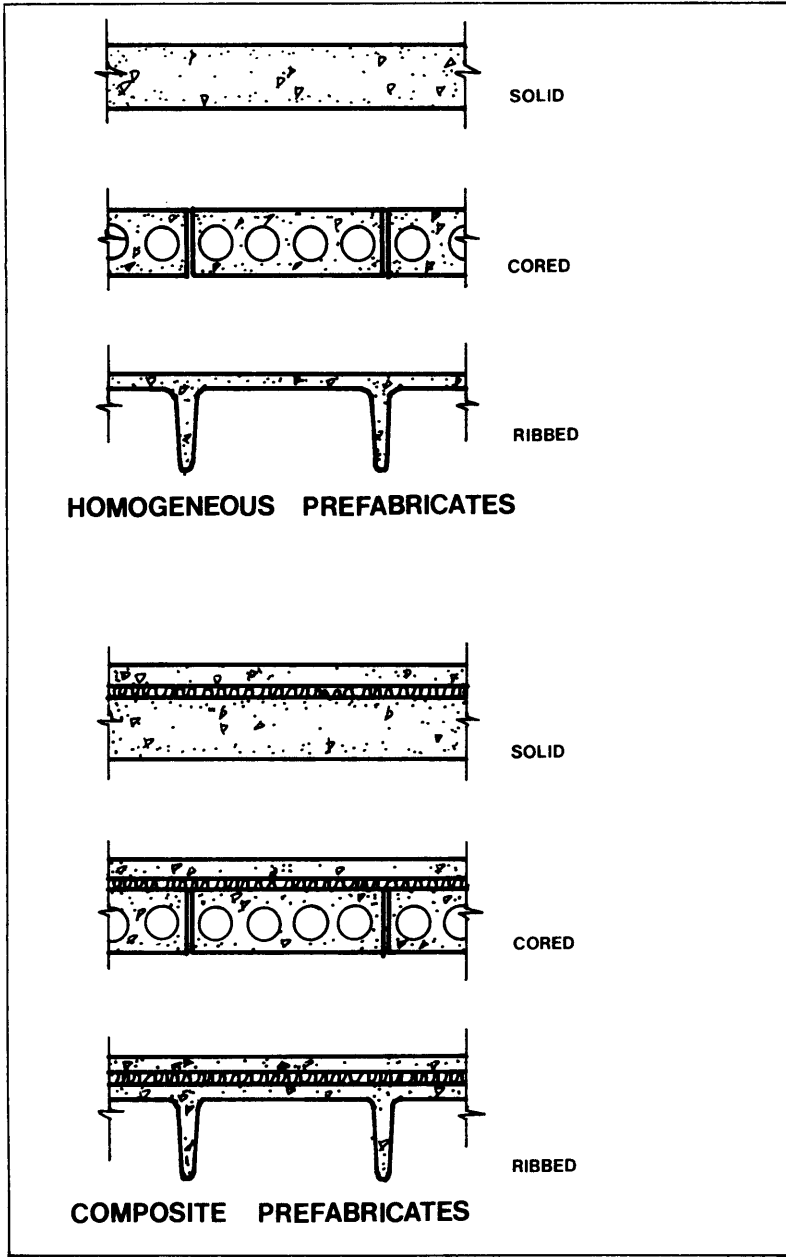

rialization reached. In this thesis, the level of industrialization to be used will be based on building from large prefabricates. This means that in the erection of a building, prefabricated wall panels finished or textured on the external facades, and large prefabricated floor units will replace the traditional building of hand-laid masonry walls, lintels, floor and roof slabs, stair flights, and landings. Internal finishes such as plastering will be completed on the site by traditional methods.

Industrialized building reduces the amount of energy expended by people and machines. Mass produced prefabricates shorten construction time and introduce the mechanization of labor. Energy consumption is further reduced by a system

of modular construction elements. Less material and equipment are used to fabricate components, resulting in the overall energy reduction of the construction process. In the factory, standardization and the repeated use of formwork are employed to further mechanize all operations. These techniques of building construction efficiency are important in the effort to produce energy conscious industrialized housing.

Residential building construction is in need of industrialization to counteract the high proportion of wages in the cost of building and the low productivity per man-hour. With the industrialization of housing, most building industry workers would have a permanent place of work that would be sheltered from the weather and

unaffected by the seasonal variations in the building trade. A proportion of their work would be taken away from the building site and carried out in the more advanced conditions common in manufacturing industries. Site work would be rationalized, construction time reduced, and the number of men needed to work under site conditions reduced. Productivity of housing construction would rise as the level of capital investment rose and better management techniques were used. In a technological age, buildings, too, must be made in a technological manner.

To create energy efficient industrialized housing, energy conserving and passive solar design concepts must be integrated with industrialized building

methods. There is much potential for energy conservation in the interrelationship of a building's subsystems. Energy conserving systems joined with industrialized building systems would produce the optimal integrated design: a comprehensive system less demanding of and more responsive to the environment.

One means of achieving less energy consumption in industrialized housing is by using construction materials that are both energy efficient and used in industrialized production. Concrete is a building material that satisfies these requirements. It is a material that is conventionally used in industrialized housing systems, has high thermal mass for heat storage, and consumes less energy in production than other materials such

as aluminum frame, concrete block, brick masonry, and steel framing.

Concrete is a free-forming plastic material that satisfies both needs of building structure and enclosure. It has wind resistance through its weight and rigidity and is a material with excellent resistance to fire damage compared to most building materials. Its characteristics are such that it does not produce smoke or noxious gas, is noncombustible, is unlikely to be a total fire loss, requires no additional structural protection, and has an excellent insurance classification with lower insurance costs.

Due to its density, the response of concrete to energy transfer is slowed as related to lighter weight materials of the same U-values. Depending on the

amount of concrete mass used in a building, the temperature variations within the building will be significantly reduced by the high thermal inertia of the material in a lower annual energy consumption and a leveling out of heat flow. The heat retention and heat lag capacity of concrete can be days, depending on its thickness.

Concrete has relatively high thermal conductivity, but lightweight concrete and thicker walls can improve insulation value. There is little sound transmission through concrete walls, which makes it an excellent construction material for housing systems. Theft and vandalism are also reduced because the walls can be penetrated only by the use of heavy materials.

As one of the most widely used construction materials, concrete's greatest disadvantage is that its quality is highly dependent on field conditions. Precast concrete minimizes this problem by lessening on-site labor and allowing erection in any weather, as contrasted with cast-in-place concrete which is entirely dependent on site conditions. Concrete mass produced into building components in a factory is a more efficient use of human energy, materials, and time. The use of precast concrete not only lessens construction time, but also all the other variables that are dependent on it, such as financing, scheduling of trade unions, and expediency of building enclosure for interior finishing.

Precast concrete components, known as

prefabricates, are grouped depending on shape and are known as blocks, panels, frames, and boxes. They are also classified according to height and size: small prefabricates with areas of less than 7 sq. ft., and large prefabricates with areas greater than 7 sq. ft.. The groups by weight are light prefabricates, weighing less than 65 pounds and meant to be erected by one man; medium prefabricates weigh up to 1000 pounds and are handled with simple mechanical equipment; and heavy prefabricates, over 1000 pounds, with erection requiring the use of heavy handling equipment.

This thesis investigates housing systems that are constructed of large prefabricated concrete panels of heavy weight, requiring the use of cranes in



erection. The prefabricates studied are both homogeneous and composite. Floor components consist of one material: concrete, and are solid, hollow, or ribbed. There is no need for thermal insulation in floors separating apartment units. Roof panels are composite prefabricates of sandwich units. The layers of the panel consist of a structural layer (concrete) and non-structural layers (insulation and finishing layers.) The non-structural layers provide thermal insulation for the exterior building skin. Wall panels are both homogeneous and composite prefabricates, depending on the wall use and location in the housing system. Exterior wall panels providing enclosure and/or structure are composite components with thermal insulation sim-

ilar to the roof panels. Interior wall panels, requiring no thermal barrier, are homogeneous prefabricates of concrete.

The possible structural systems for industrialized housing in precast concrete are:

- 1) based on a system of skeleton construction,
- 2) constructed with loadbearing walls of large panels, or
- 3) formed from prefabricated box units.

The housing systems developed in this thesis are constructed with loadbearing walls of large concrete panels. A concrete loadbearing structure satisfies the requirements of structure, enclosure, and thermal mass with one system of components. Hence, an exterior composite panel performs many functions at once, resulting

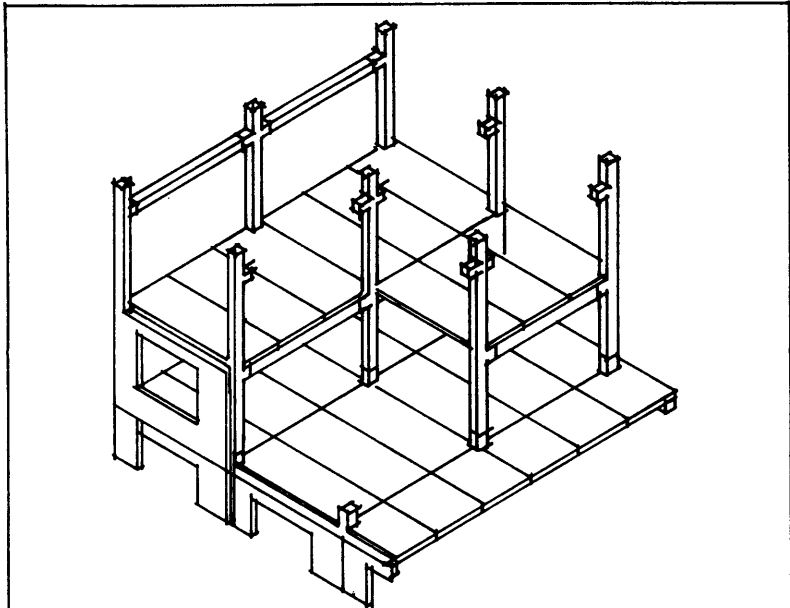

FRAMES

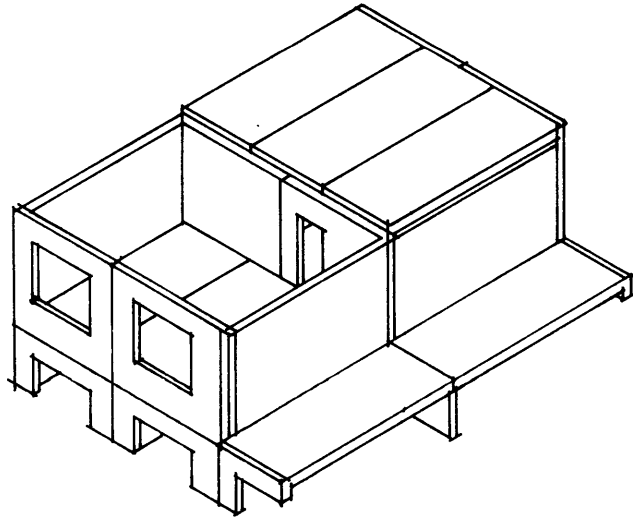

PANELS

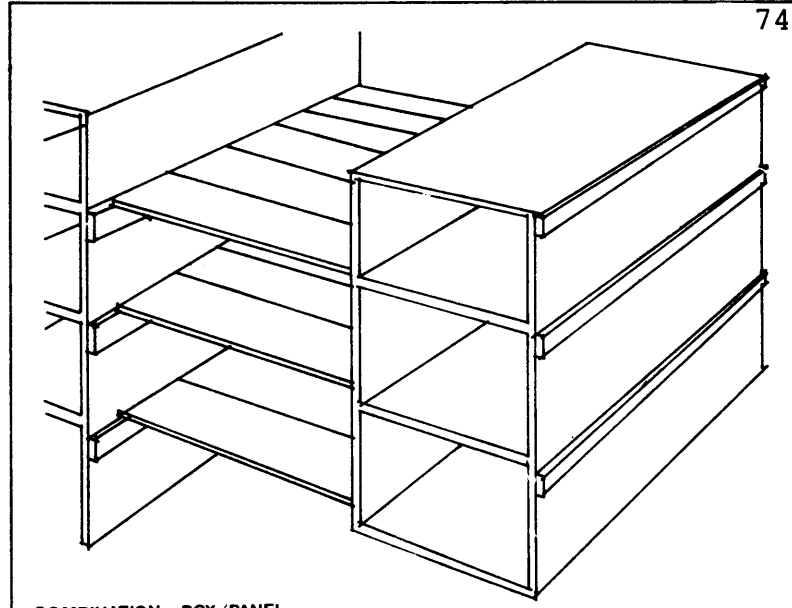

COMBINATION BOX/PANEL

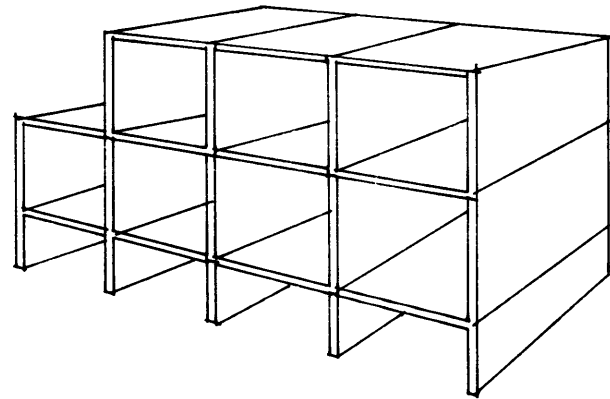

BOXES

STRUCTURAL SYSTEMS

in energy savings. Its composite mass of concrete and insulation supports the floor and wall above, and reduces heat loss through the building skin while providing heat storage for solar radiation. Homogeneous concrete interior wall panels create the desired visual and acoustic barriers between apartment units and between rooms within individual apartments, while also increasing thermal mass for heat retention.

The components developed in the thesis are roof panels of composite prefabricates, floor panels of homogeneous prefabricates, interior panels of loadbearing and non-loadbearing homogeneous prefabricates, and exterior panels of loadbearing and non-loadbearing composite prefabricates. The use of loadbearing

or non-loadbearing components is dependent on the individual housing design and construction system. Concrete used in the panel sections is lightweight concrete, rather than normal weight concrete. Structural lightweight concrete weighs from 80 to 115 pounds per cubic foot and has greater thermal insulating properties than normal weight concrete.

Standardization of components is dependent upon two factors: the technique of construction, and the architectural conception of the project. These factors determine the number of different types of prefabricated components, with the desire being to restrict the number of types of components used. In using a restricted range of large prefabricated units, architectural design

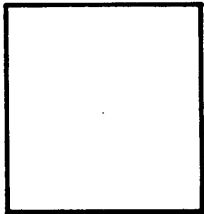

8'

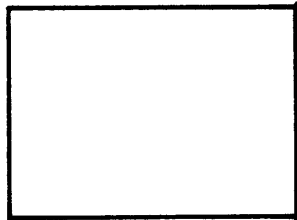

12'

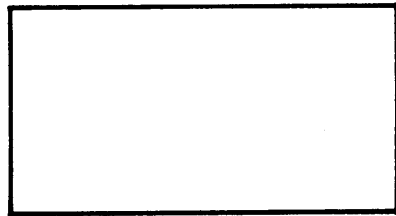

16'

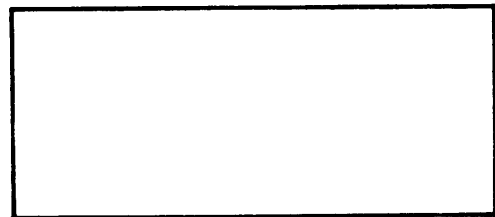

20'

BEARING WALLS

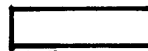

5'8"



8'

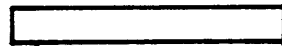

11'4"



12'



16'

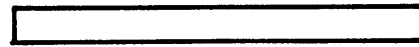

17'

BEAMS



40'

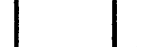

36'



32'



28'



24'



20'



16'



12'



CORED SLABS

PRECAST CONCRETE  
STRUCTURAL COMPONENTS OF PANEL SYSTEM

could become rather stereotyped. With mass production in housing, the problem arises of maximizing the opportunity to create housing that responds to individuality. In prefabricated building construction, dwellings are usually produced in large series comprising a small number of individual types in a particular housing complex. To combat this typical result, there must be variety in sizes, finish, and technical equipment of dwellings. It is necessary to expand the interrelationship between plan, elevational treatment, and structural design to achieve flexible layouts and a high degree of adaptability.

A housing system must be flexible in planning, change and use, while providing a variety of apartment arrangements as

needed. In industrialized housing, unity and variety are key concepts in the investigation of prefabrication, service modules, geometry, and fluid forms. The housing variables in a system are the environment, the relationship to the ground, character, flexibility for change, flexibility for choice (sizes), privacy, and the amount of daylight.

Standardized components could be used in housing systems in providing a wide range of unit types and assuring within each unit a variety of planning alternatives. The studies in this thesis attempt to express a structural concept and to provide flexibility in interior planning and unit grouping within the structural restrictions set by the limits of prefabricated components. The

aim of the created housing environment is to relate activities to space, daylight, and circulation while reducing the overall energy consumption.

An industrialized precast concrete housing system can readily be integrated with passive solar/energy conservation concepts. For example, by careful design of the industrialized components and their connections, heat loss through the building envelope is minimized. The high thermal characteristics of concrete can be further increased by proper building orientation. A glazed southern exposure will allow direct sunlight to penetrate the apartment unit and be absorbed by the surrounding concrete wall panels for release later at night into the space. Further methods of decreasing energy

consumption are developed in the following sections. The incorporation of passive solar/energy conservation concepts surveyed in the previous chapter would produce a comprehensive energy efficient industrialized housing system with the desired flexibility, variability, and adaptability.

## II. Integration of Energy and Industrialization Concepts

In this section, components have been developed for an industrialized housing system in precast concrete constructed with loadbearing walls of large panels. The components consist of roof panels of composite prefabricates, floor panels of homogeneous prefabricates, interior loadbearing panels of homogeneous prefabricates, and exterior panels of loadbearing composite prefabricates. Within each of these general categories, components have been designed which incorporate passive solar/energy conservation concepts that are applicable to the climate of the Boston region.

Components designed for an energy conserving building are based on a well-

defined range of temperatures and humidity for a particular region. The Boston region has a temperate climate consisting of a greater number of underheated periods than overheated periods. Hence, structures must have a high resistance to heat loss and be able to retain as much heat as possible. Heat loss in the winter months is of greater concern than heat gain in the short summer months.

Seasonal winds are from the northwest in the winter and the southwest in the summer. Housing systems should have minimal exposure on the northern orientations, with services such as stairs, corridors, elevators, and entrances located on this exposure to create a buffer zone for the living areas. Also characteristic of the Boston climate are large amounts of

precipitation, and intermittant periods of clear sunny days followed by extended periods of cloudy, overcast days. Therefore, for a housing system which is passively heated, there must be high thermal mass to retain heat.

The climactic data of the Boston area is as follows:

general data --

climate: temperate  
 latitude:  $42^{\circ} - 2'N$   
 # of annual heating degree days: 5715  
 total percent of possible sunshine:  
     57%  
 average wind speed: 15 mph from W  
 average relative humidity: 69%  
 annual # of sunshine hours: 2615

January data --

percent of possible sunshine: 47%  
 # of sunshine hours: 148  
 average temperature:  $30^{\circ}F$   
 average day temperature:  $33.5^{\circ}F$

average night temperature:  $26.5^{\circ}F$   
 wind speed: 17 mph from W  
 relative humidity: 68%

July data --

percent of possible sunshine: 64%  
 # of sunshine hours: 300  
 average temperature:  $74^{\circ}F$   
 average day temperature:  $78^{\circ}F$   
 average night temperature:  $69.5^{\circ}F$   
 wind speed: 10 mph from WSW  
 relative humidity: 70%

sun angles --

March 21:  $48^{\circ}$   
 June 22:  $71.5^{\circ}$   
 Sept. 23:  $48^{\circ}$   
 Dec. 23:  $24.5^{\circ}$

For an energy-efficient industrialized housing system, the primary concerns in the development of components for the system are to have prefabricates which have a high resistance to heat loss, have large thermal mass for heat collection and stor-



age, have thermally tight connection between components, can be combined to achieve a variety of building configurations, and apartment units, and can incorporate passive solar/energy conservation requirements. The drawings which follow explore prefabricates responding to these requirements.

Wall Sandwich Panels  
Sandwich Panel Ties  
Panel Connections  
Balcony Components  
Terrace Components

Wall sandwich panels are composite prefabricates which consist of three layers: a structural layer and two non-structural layers, insulation and finishing layer. The structural layer is located on the interior side of the panel to provide a large thermal mass for heat collection and storage. The insulation prevents heat losses from traveling through the structural wall to the outside layer. The variety of drawings indicate the divergence of U values resulting from changing the thickness and type of concrete and insulation in the wall sandwich panels. Of the wall sections, the most efficient

combine two layers of structural lightweight concrete with polyurethane rigid insulation.

The thickness of the sandwich panel ties is important in determining heat loss that can be conducted from the interior panel to the outer panel by the metal tie. A lighter exterior panel will require a thinner metal tie for support, resulting in less heat loss than a heavier panel.

Of equal importance to the composition of wall sandwich panels are the connections of the panels. A building envelope is not efficient if there are large heat losses through the floor slab at the exterior of the structure, and at the connection of two wall panels. A large number of drawings concerning panel connections, balcony components, and terrace

components explore methods of preventing thermal losses through the floor slab. The principle is to maintain a continuous wall of insulation through all structural joints.

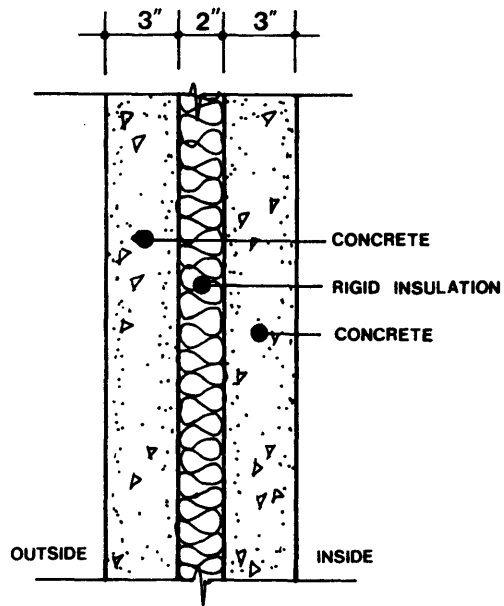

SURFACE FILM (OUTSIDE)	.17
6" NORMAL WEIGHT CONCRETE	.46
2" POLYSTYRENE INSULATION	9.20
SURFACE FILM (INSIDE)	.68

TOTAL R 10.51  
 U = .095

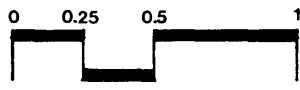

SCALE IN FEET

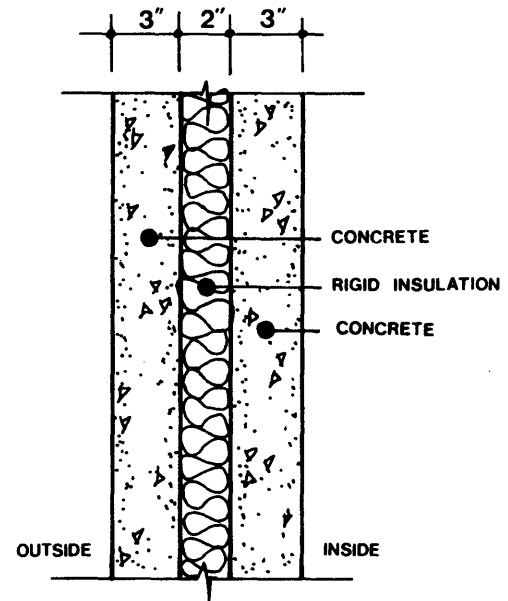

SURFACE FILM (OUTSIDE)	.17
6" NORMAL WEIGHT CONCRETE	.46
2" POLYURETHANE INSULATION	14.70
SURFACE FILM (INSIDE)	.68

TOTAL R 16.01  
 U = .062

WALL SANDWICH PANELS

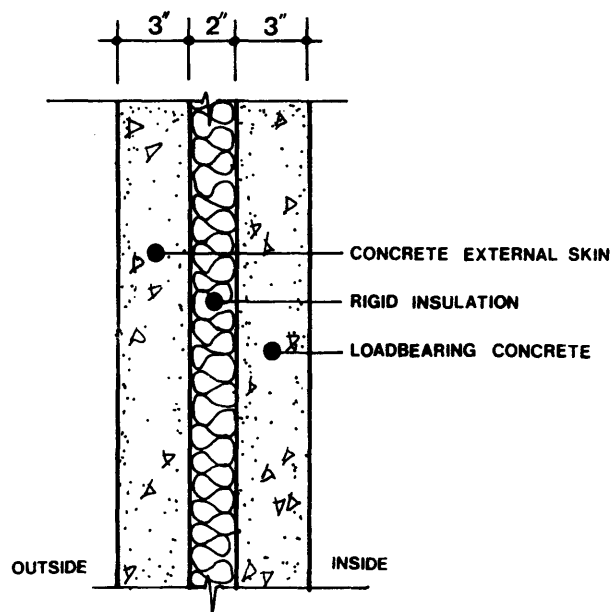

SURFACE FILM (OUTSIDE)	.17
6" STRUCTURAL LIGHTWEIGHT CONCRETE	1.15
2" POLYSTYRENE INSULATION	9.20
SURFACE FILM (INSIDE)	.68
<hr/>	
TOTAL R	11.20
U =	.089

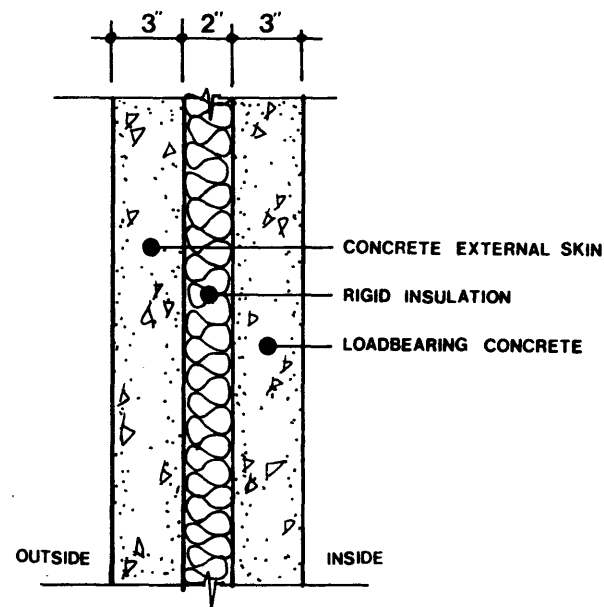
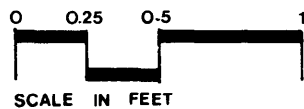

SURFACE FILM (OUTSIDE)	.17
6" STRUCTURAL LIGHTWEIGHT CONCRETE	1.15
2" POLYURETHANE INSULATION	14.70
SURFACE FILM (INSIDE)	.68
<hr/>	
TOTAL R	16.70
U =	.059

WALL SANDWICH PANELS

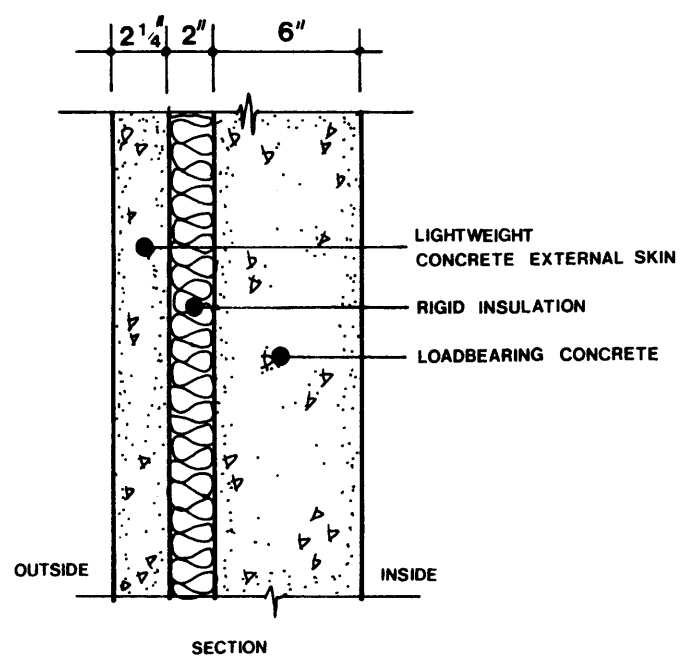

SURFACE FILM (OUTSIDE)	.17
8.25" STRUCTURAL LIGHTWEIGHT CONCRETE	1.57
2" POLYURETHANE INSULATION	14.70
SURFACE FILM (INSIDE)	.68
<hr/>	
<b>TOTAL R</b>	<b>17.12</b>
<b>U =</b>	<b>.058</b>

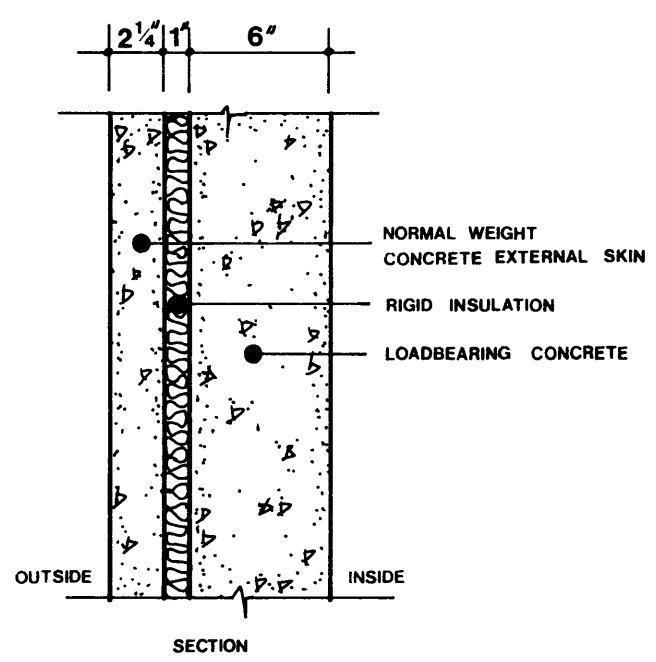
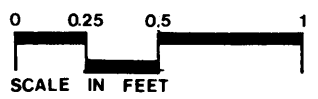

SURFACE FILM (OUTSIDE)	.17
8.25" NORMAL WEIGHT CONCRETE	1.57
1" POLYSTYRENE INSULATION	4.60
SURFACE FILM (INSIDE)	.68
<hr/>	
<b>TOTAL R</b>	<b>7.02</b>
<b>U =</b>	<b>.142</b>

**WALL SANDWICH PANELS**

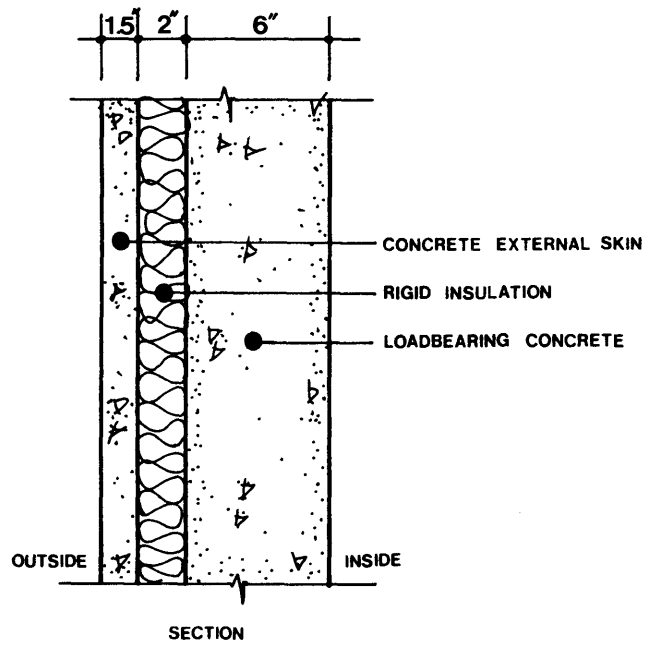

SURFACE FILM (OUTSIDE)	.17
7.5" STRUCTURAL LIGHTWEIGHT CONCRETE	1.43
2" POLYURETHANE INSULATION	14.70
SURFACE FILM (INSIDE)	.68
<b>TOTAL R</b>	<b>16.98</b>
<b>U =</b>	<b>.058</b>

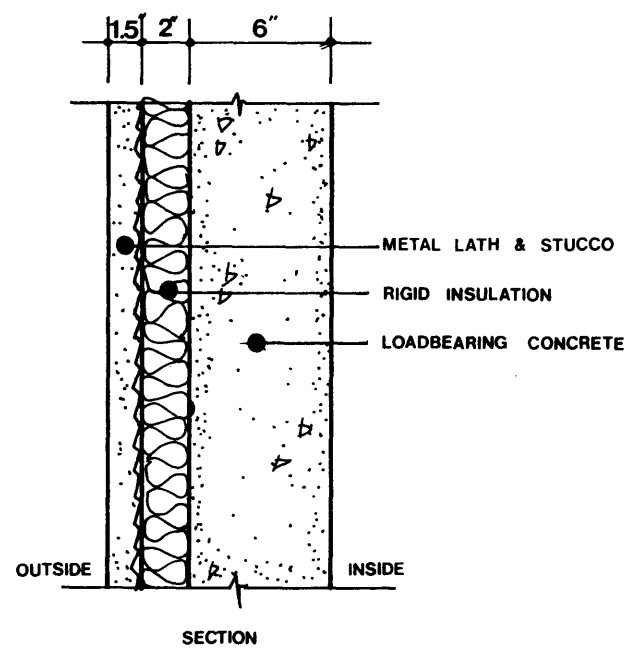
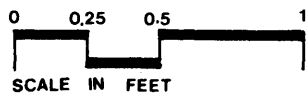

SURFACE FILM (OUTSIDE)	.17
6" STRUCTURAL LIGHTWEIGHT CONCRETE	1.13
2" POLYURETHANE INSULATION	14.70
METAL LATH & STUCCO	.12
SURFACE FILM (INSIDE)	.68
<b>TOTAL R</b>	<b>16.80</b>
<b>U =</b>	<b>.059</b>

**WALL SANDWICH PANELS**

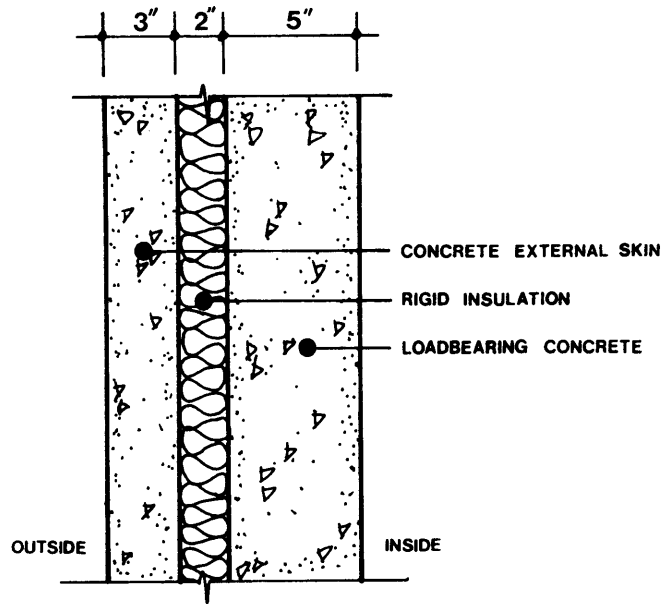

SURFACE FILM (OUTSIDE)	.17
8" STRUCTURAL LIGHTWEIGHT CONCRETE	1.54
2" POLYURETHANE INSULATION	14.70
SURFACE FILM (INSIDE)	.68
<b>TOTAL R</b>	<b>17.09</b>
<b>U =</b>	<b>.058</b>

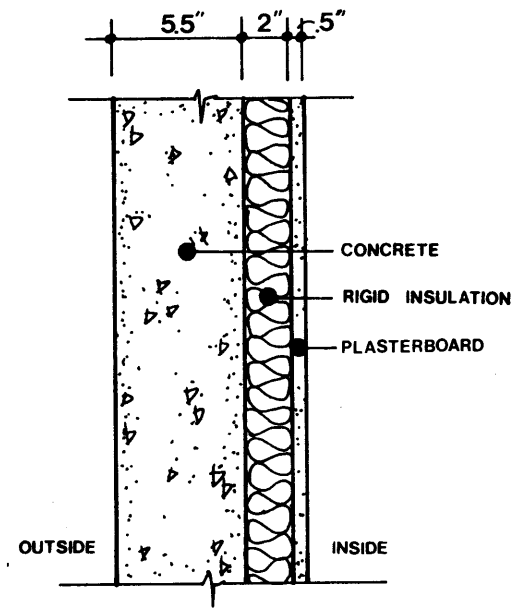
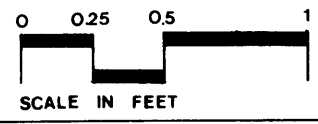

SURFACE FILM (OUTSIDE)	.17
5.5" STRUCTURAL LIGHTWEIGHT CONCRETE	.95
2" INSULATION	8.06
.5" PLASTERBOARD	.45
SURFACE FILM (INSIDE)	.68
<b>TOTAL R</b>	<b>10.25</b>
<b>U =</b>	<b>.10</b>

**WALL SANDWICH PANELS**



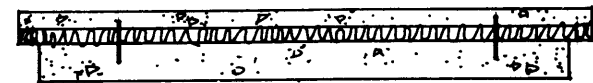
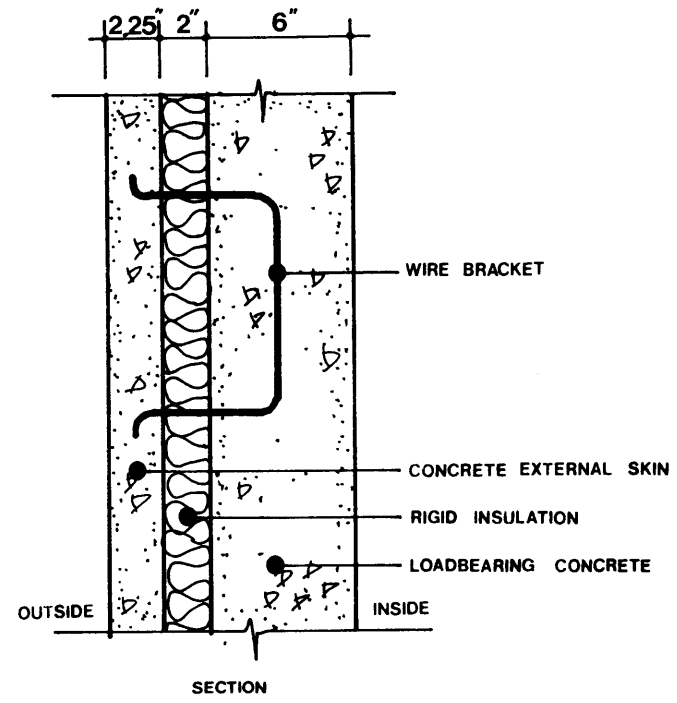
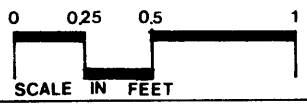
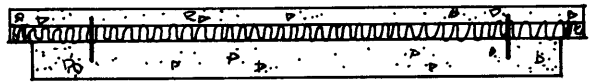
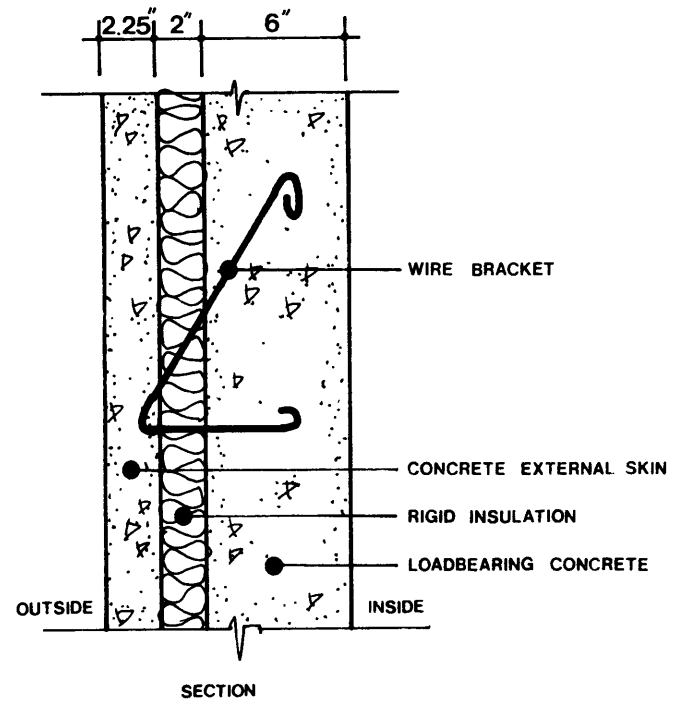

SANDWICH PANEL TIES

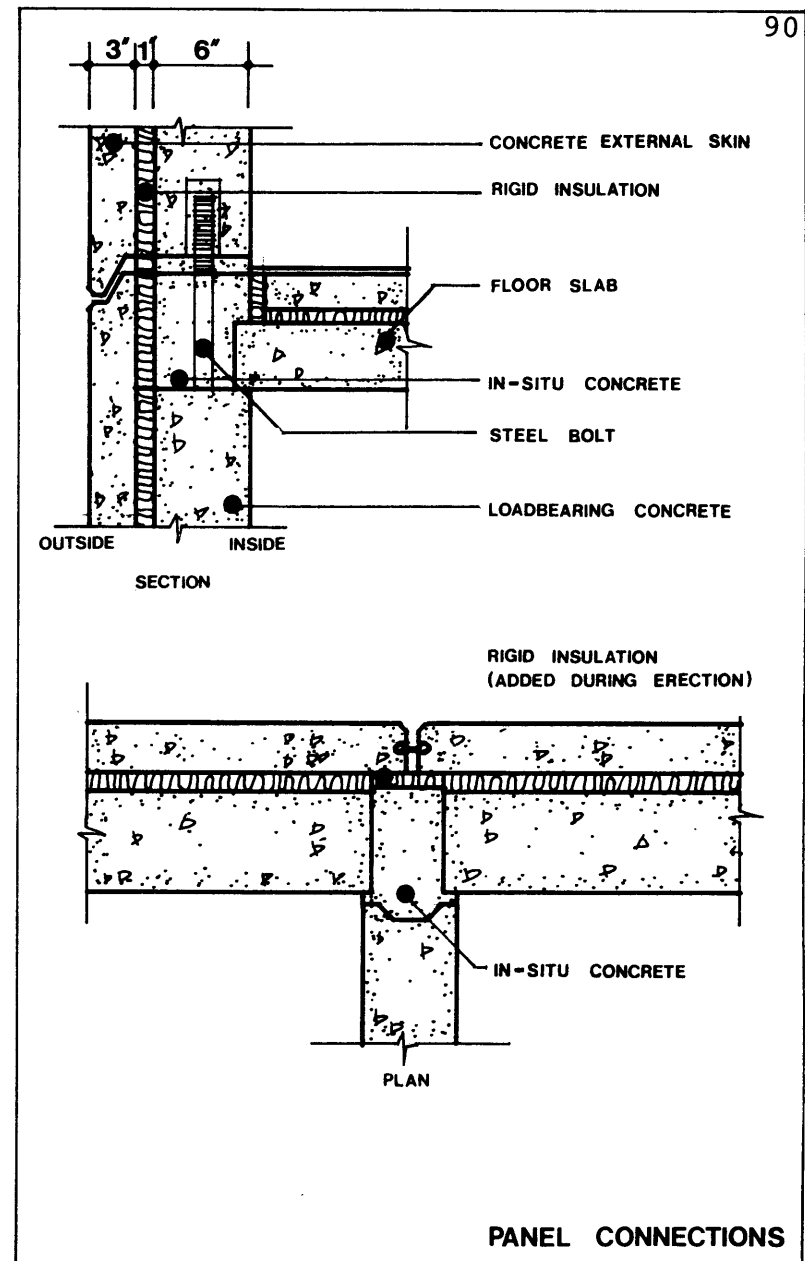
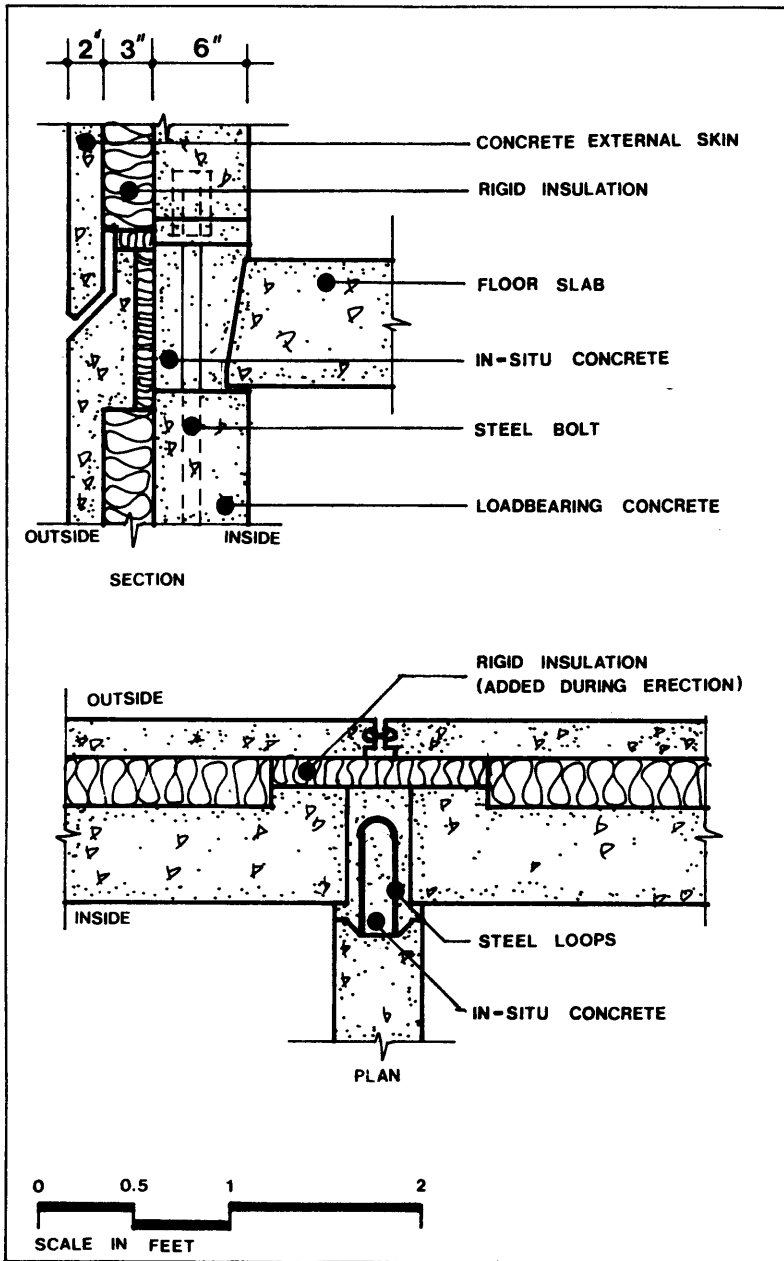

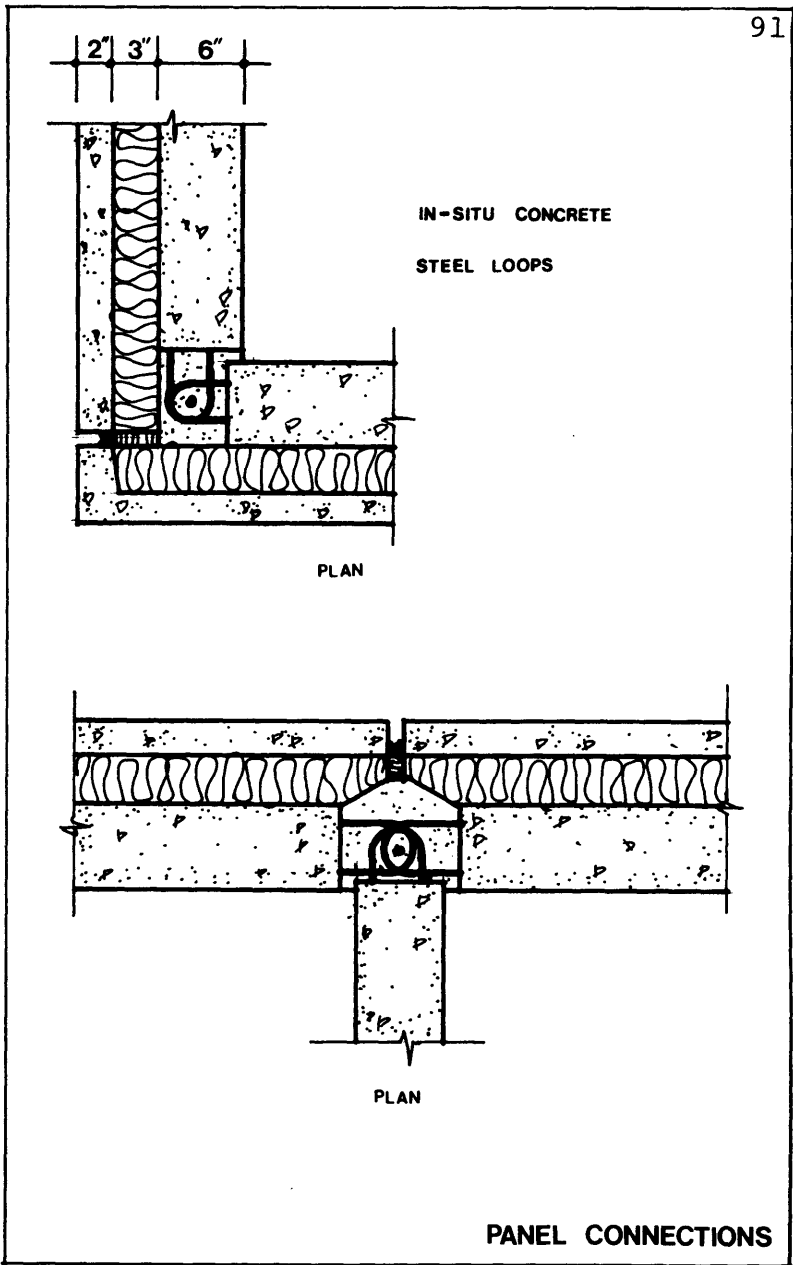
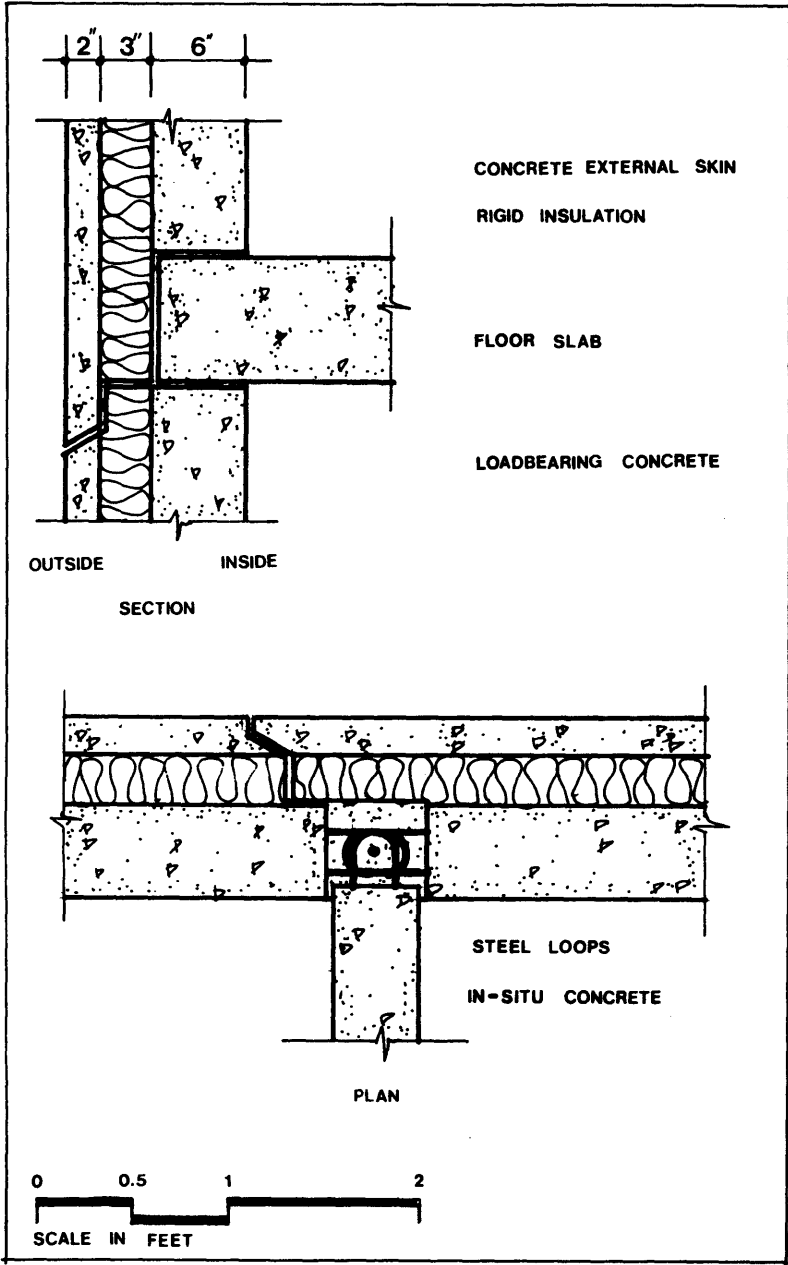

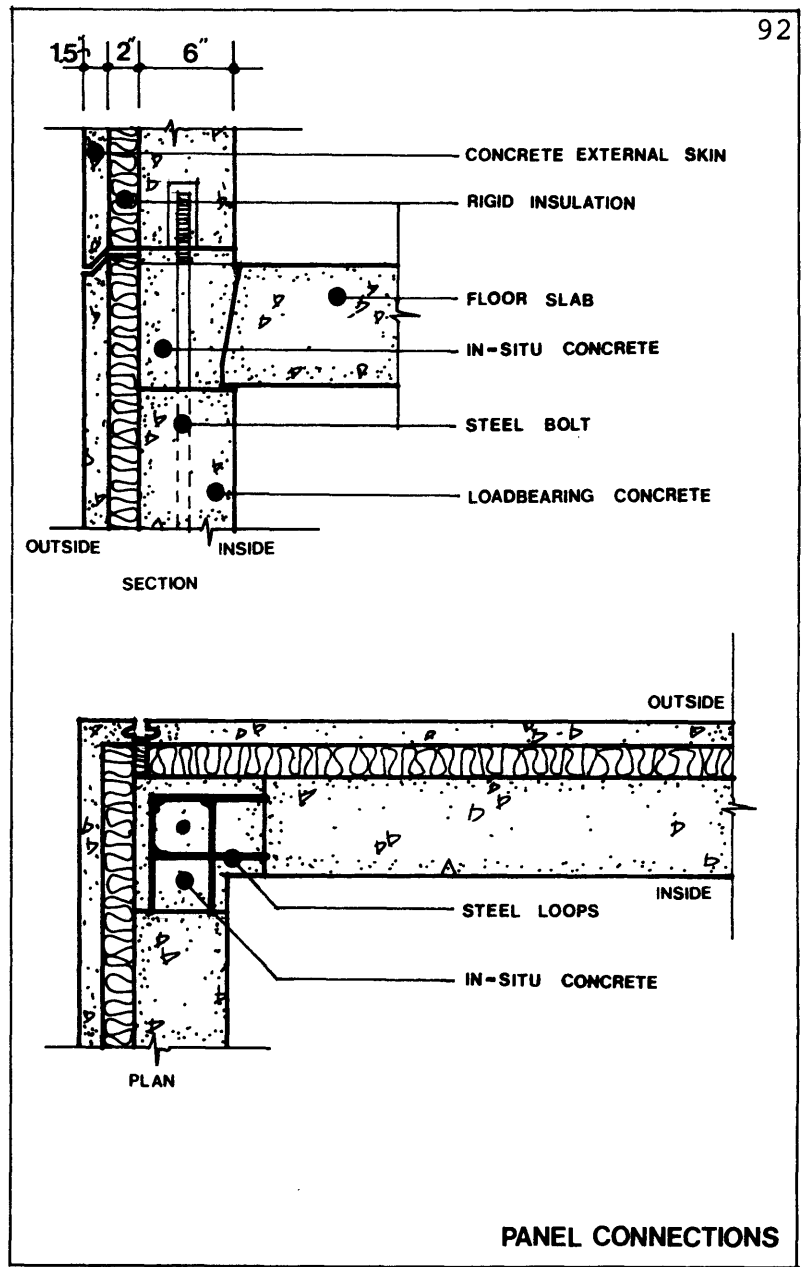
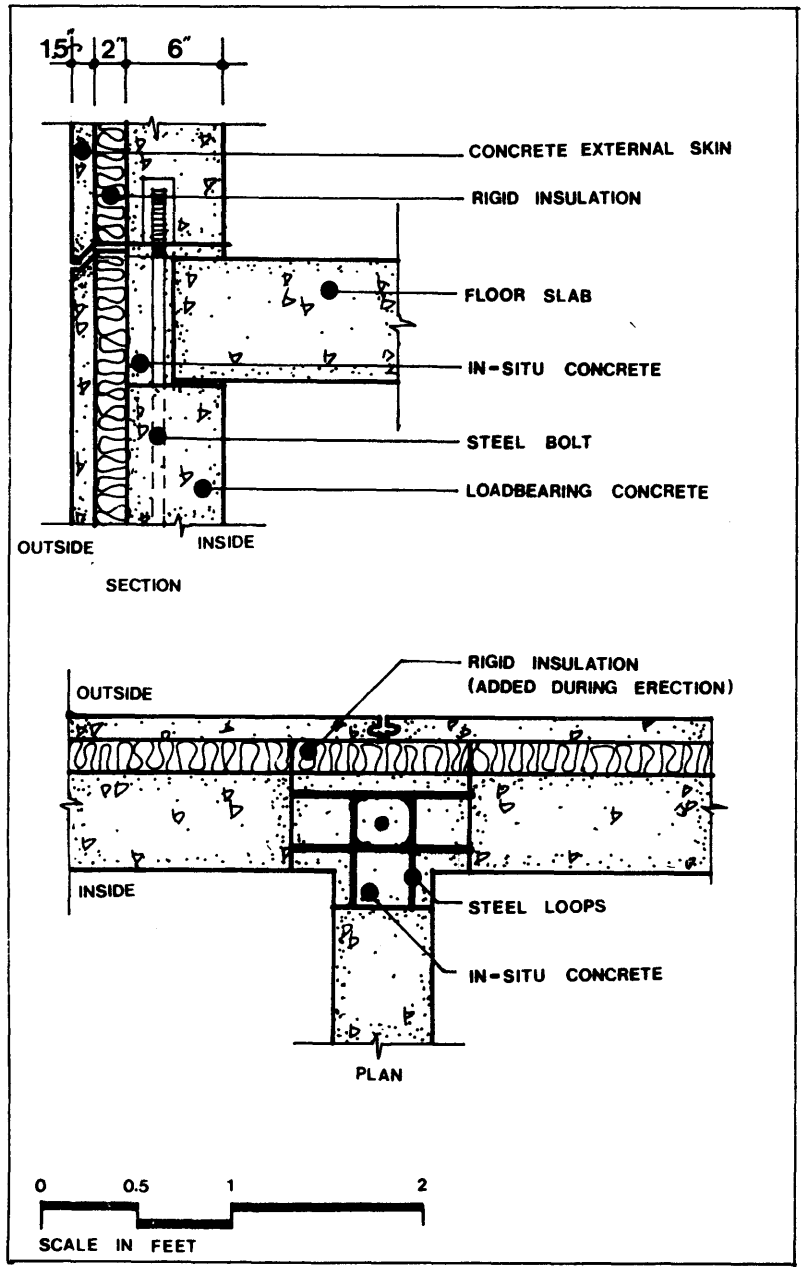

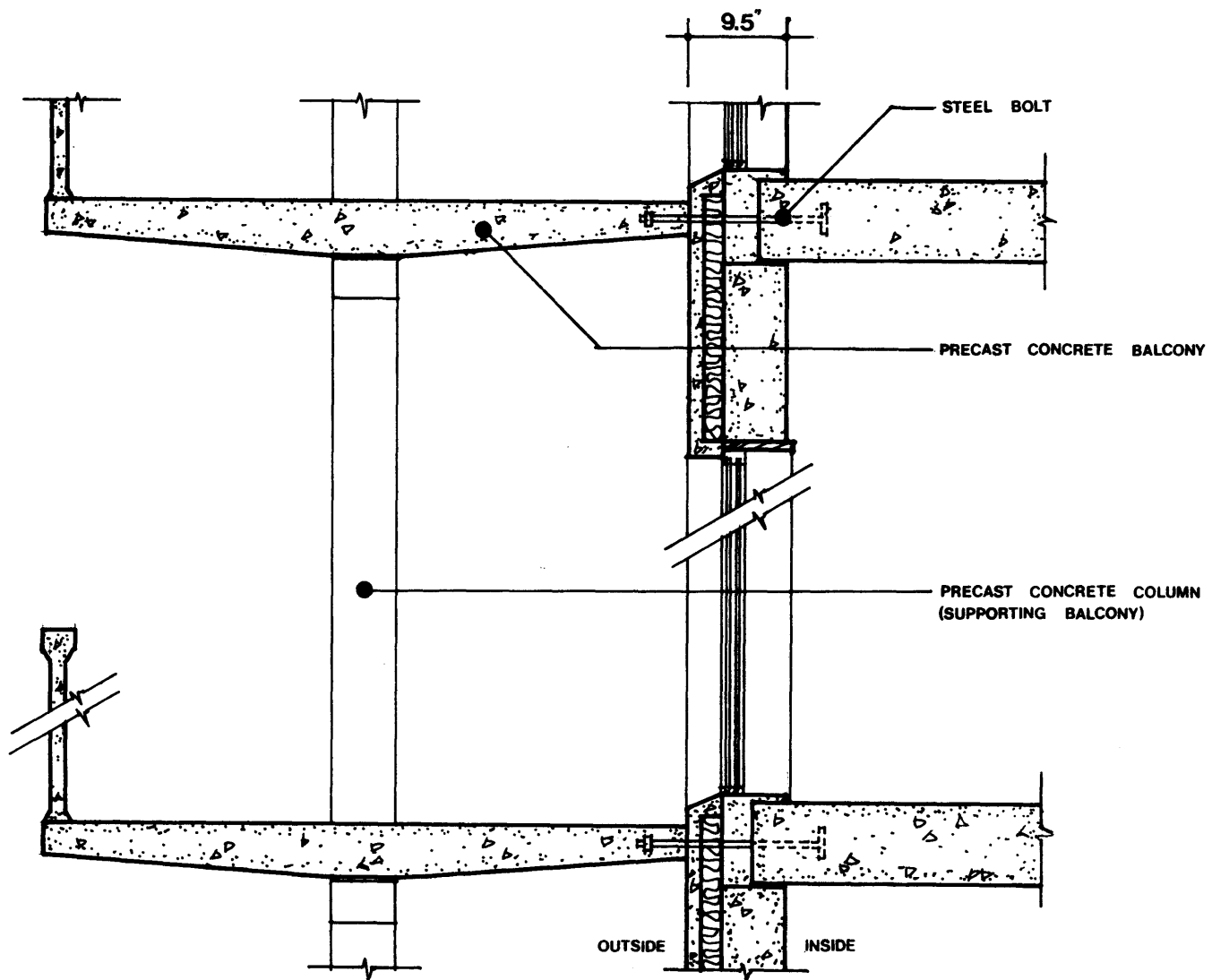

SECTION

0 0.5 1 2  
SCALE IN FEET

BALCONY COMPONENTS

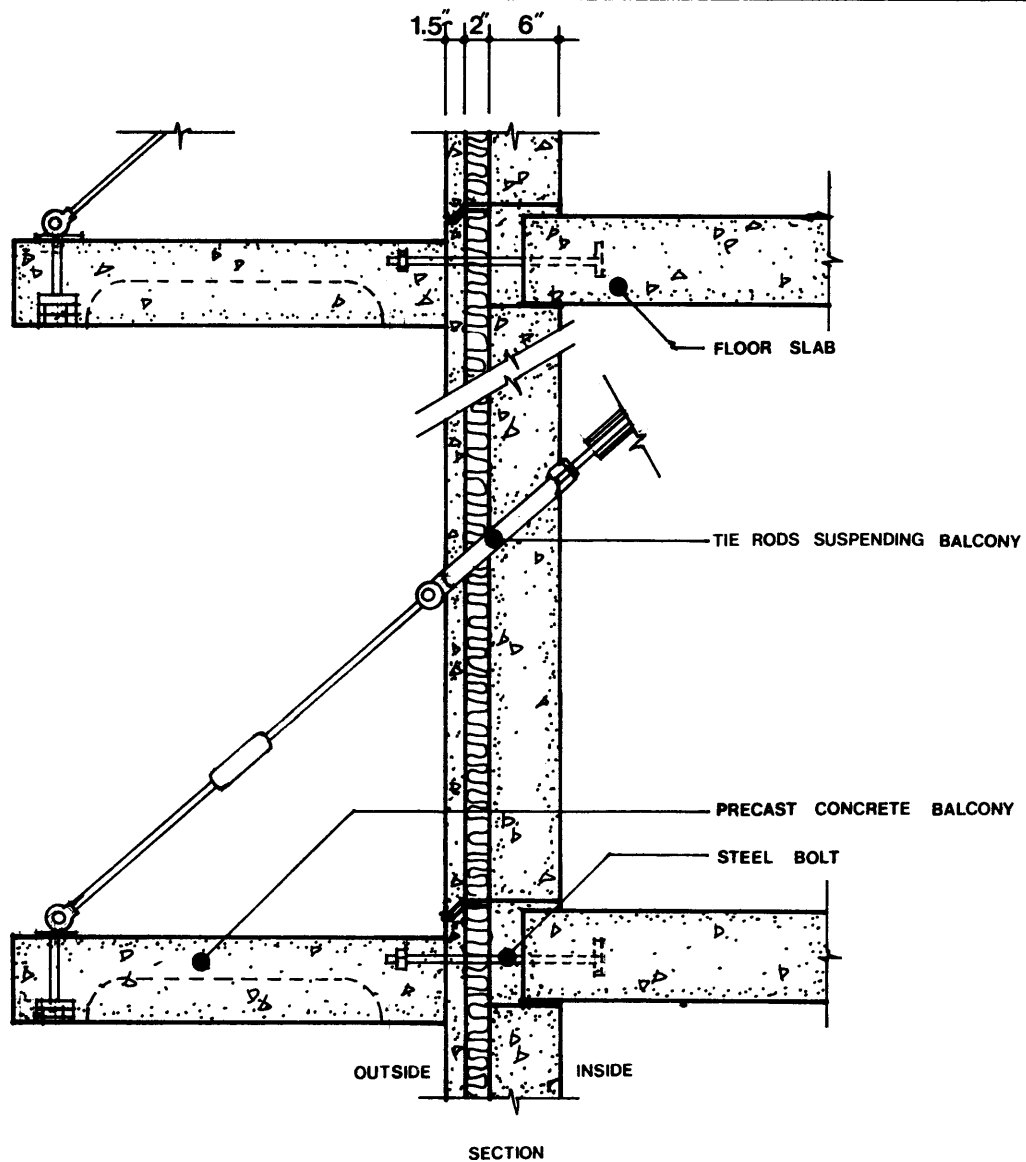

BALCONY COMPONENTS

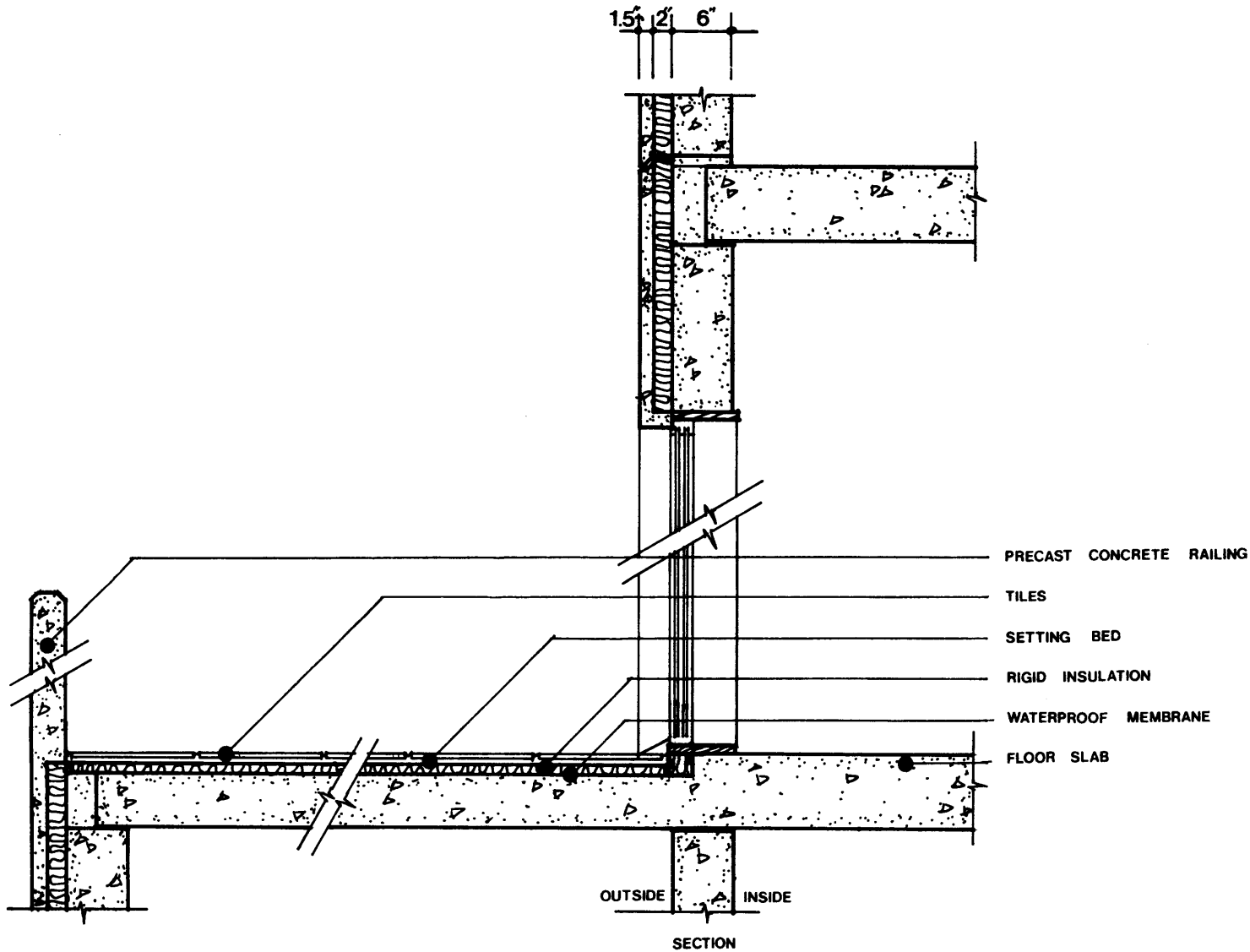

TERRACE COMPONENTS

Sandwich Panels with Windows  
 Insulating Window Films  
 Insulated Window Shutters  
 Styrofoam Bead Windows  
 Window Sun Shades

Wall sandwich panels with windows have the same requirements for efficient panel composition and connections as standard wall panels, but have the increased heat losses due to the high conductivity of glass. While double glazing in wood window frames lessens heat losses, the location of the window frames is important for lessening infiltration and conduction through the frame. Window frames located on the external layer of sandwich panels will conduct the cold temperatures to the interior loadbearing layer. Hence, the frames should be placed against the

insulation or the internal loadbearing layers. Drawings illustrate possible methods of placing window frames in wall sandwich panels, and possible techniques for insulation of the glazing at night, to stop heat losses to the outside. Heat losses through the glazing itself can be lessened by using an insulating film over the glass, by covering the glass with insulated window shutters, or by using a styrofoam bead system between the layers of glazing. A group of drawings also illustrates wall sandwich panels with casing for sun shades or shutters incorporated into the panel. Sun shades will eliminate the penetration of unwanted summer sun through glazed areas, and if insulated, can provide a thermal barrier at night in the winter.



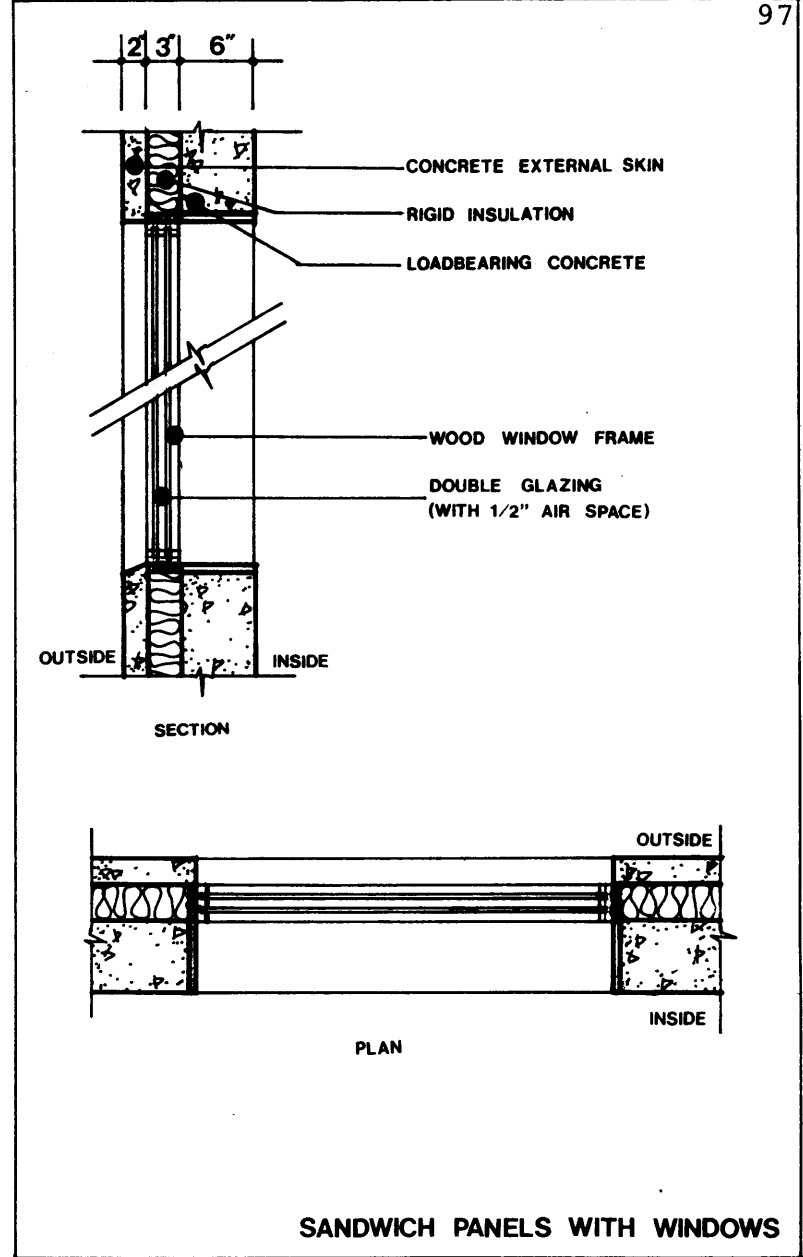
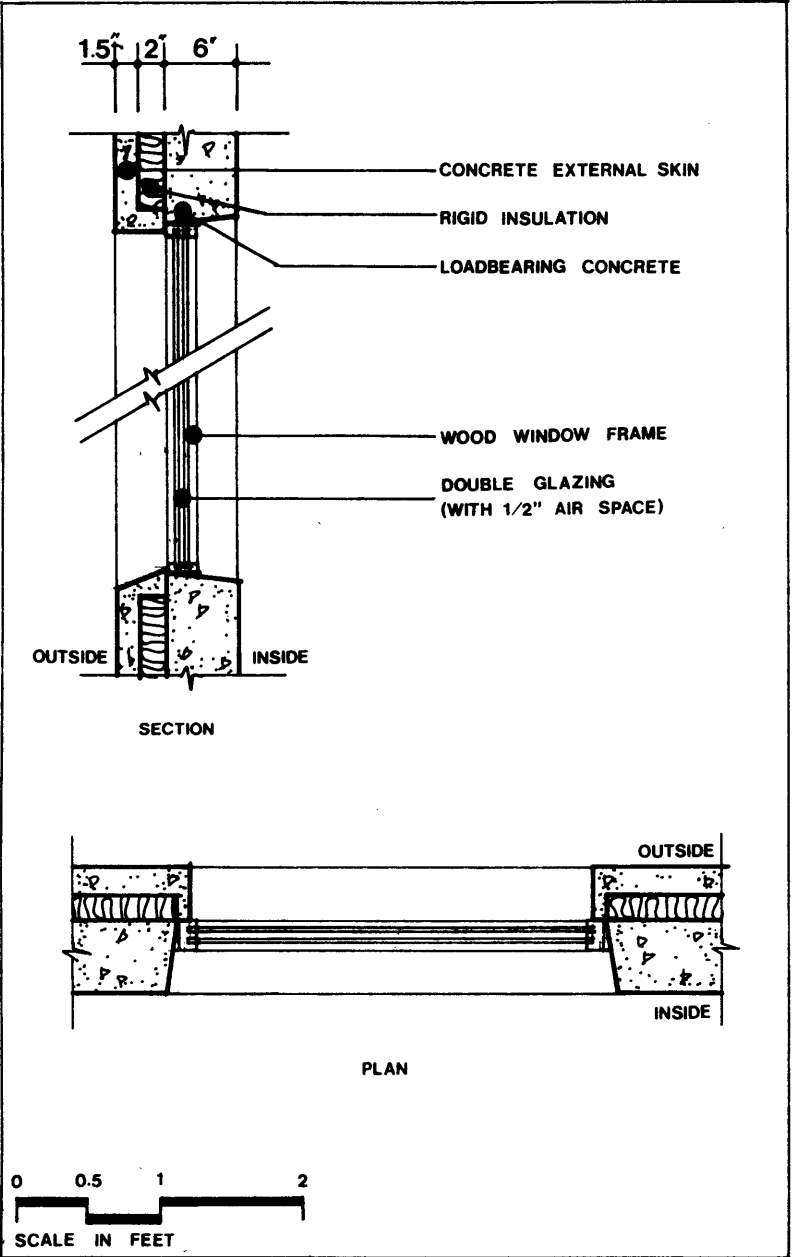

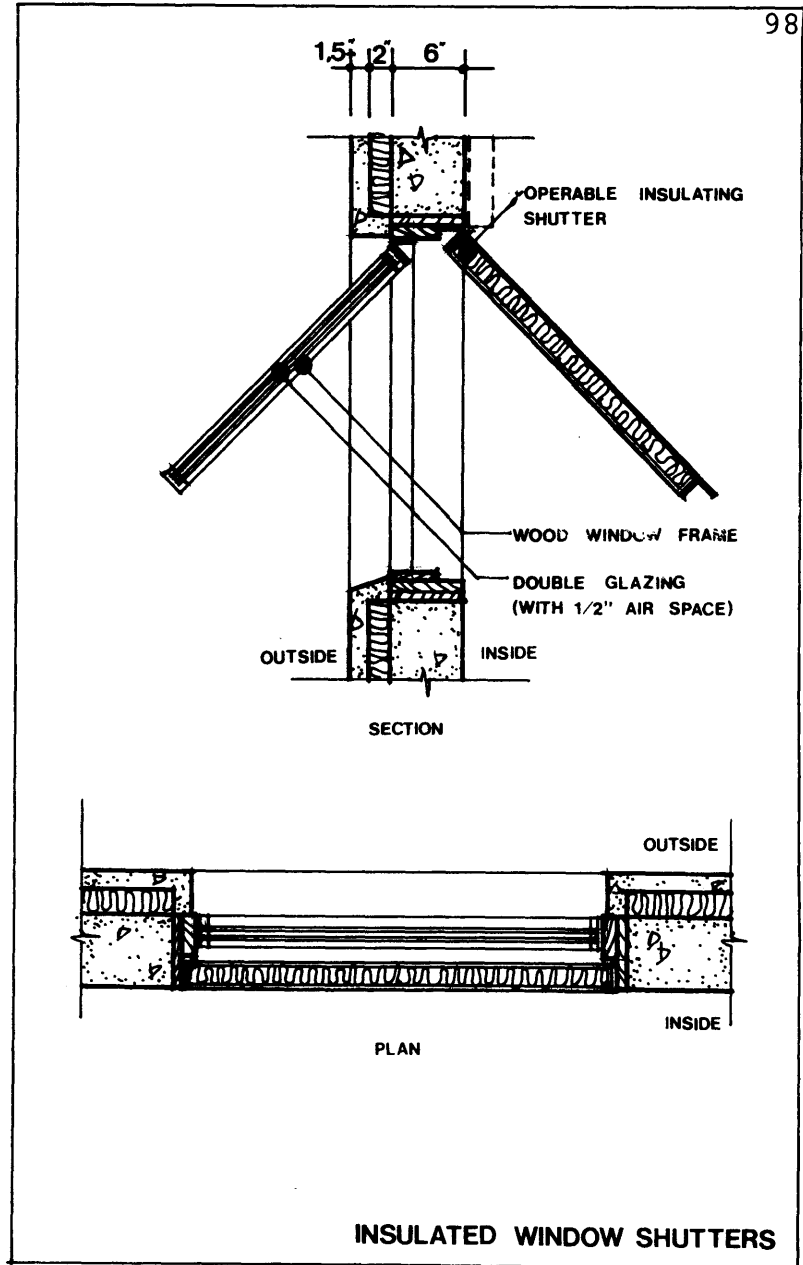
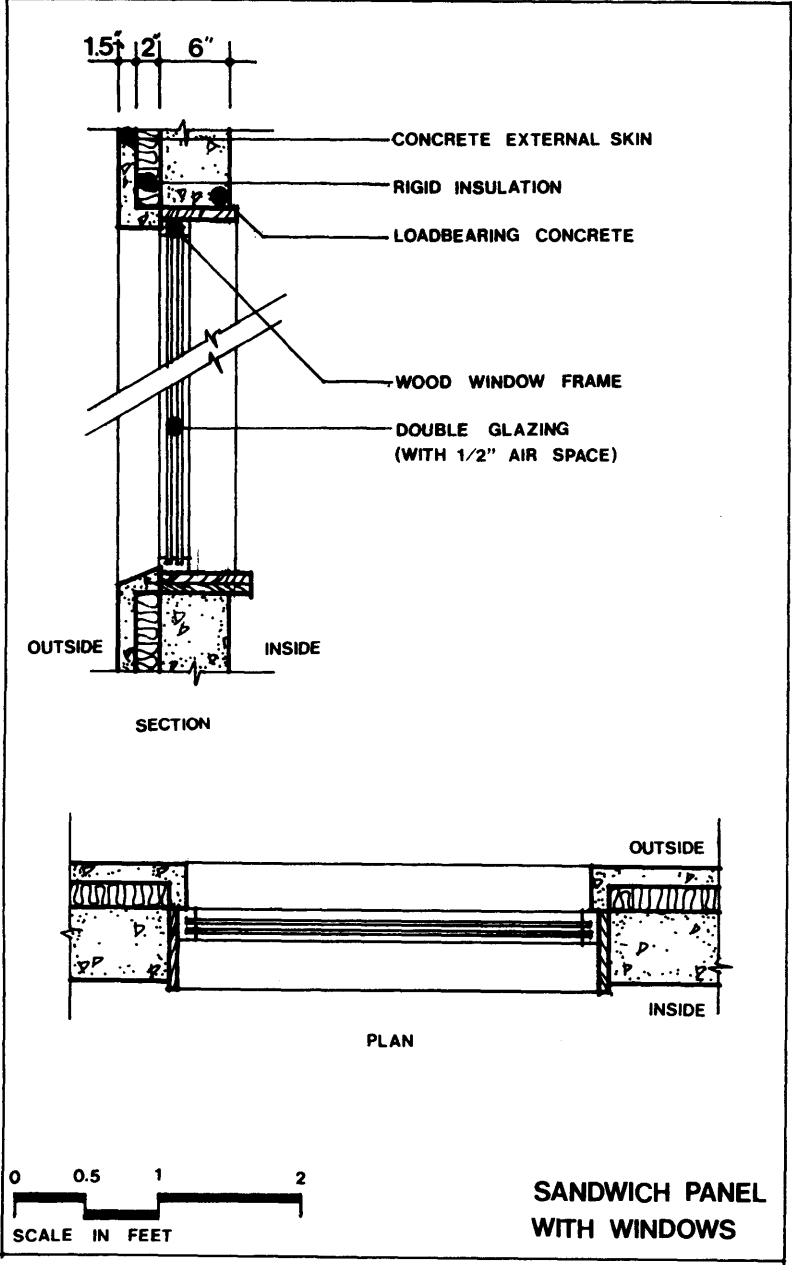

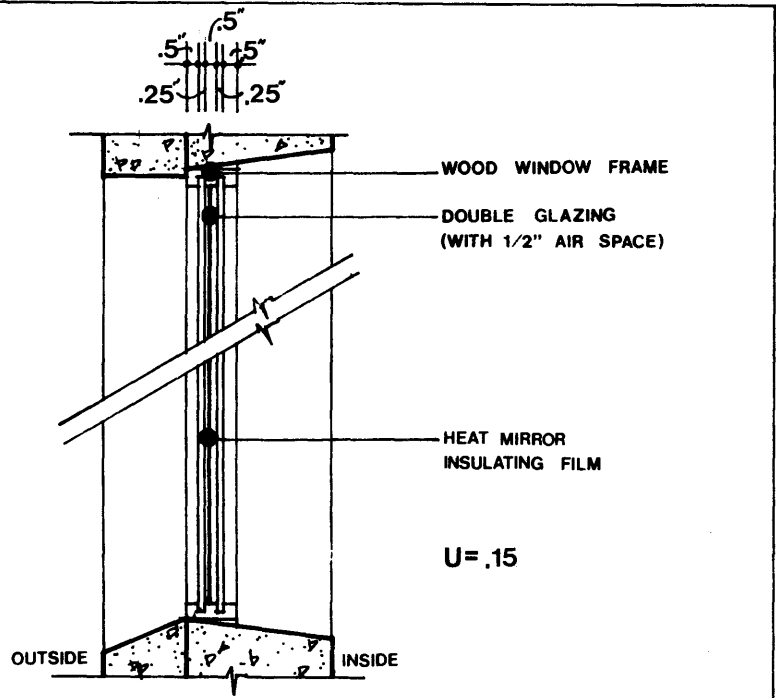

U = .15

SECTION

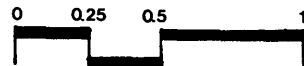
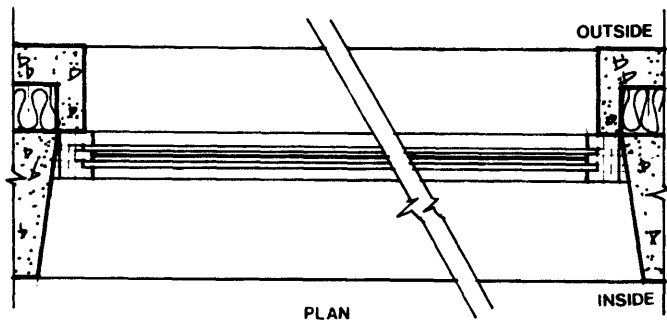

SCALE IN FEET

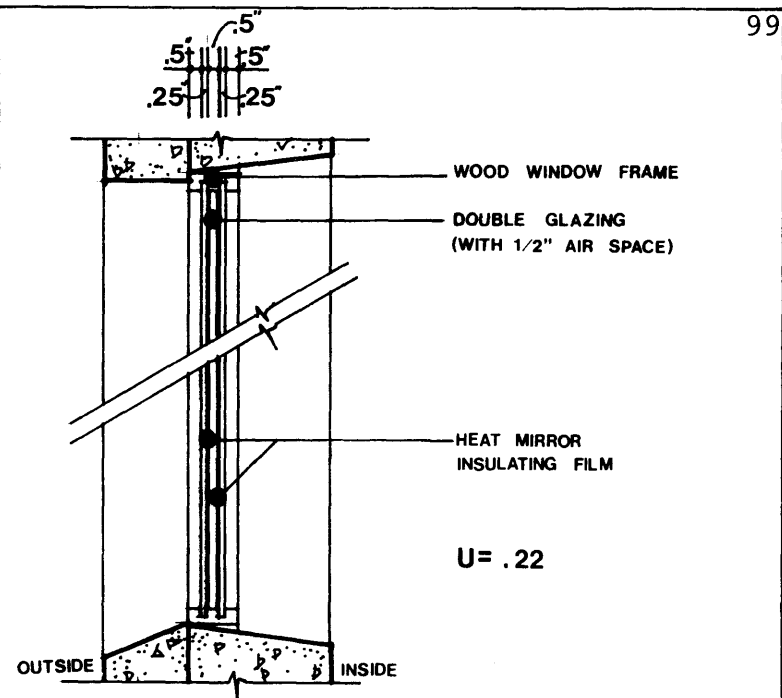

U = .22

SECTION

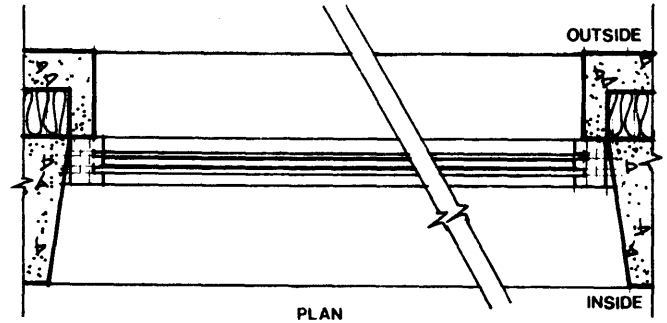

INSULATING WINDOW FILM

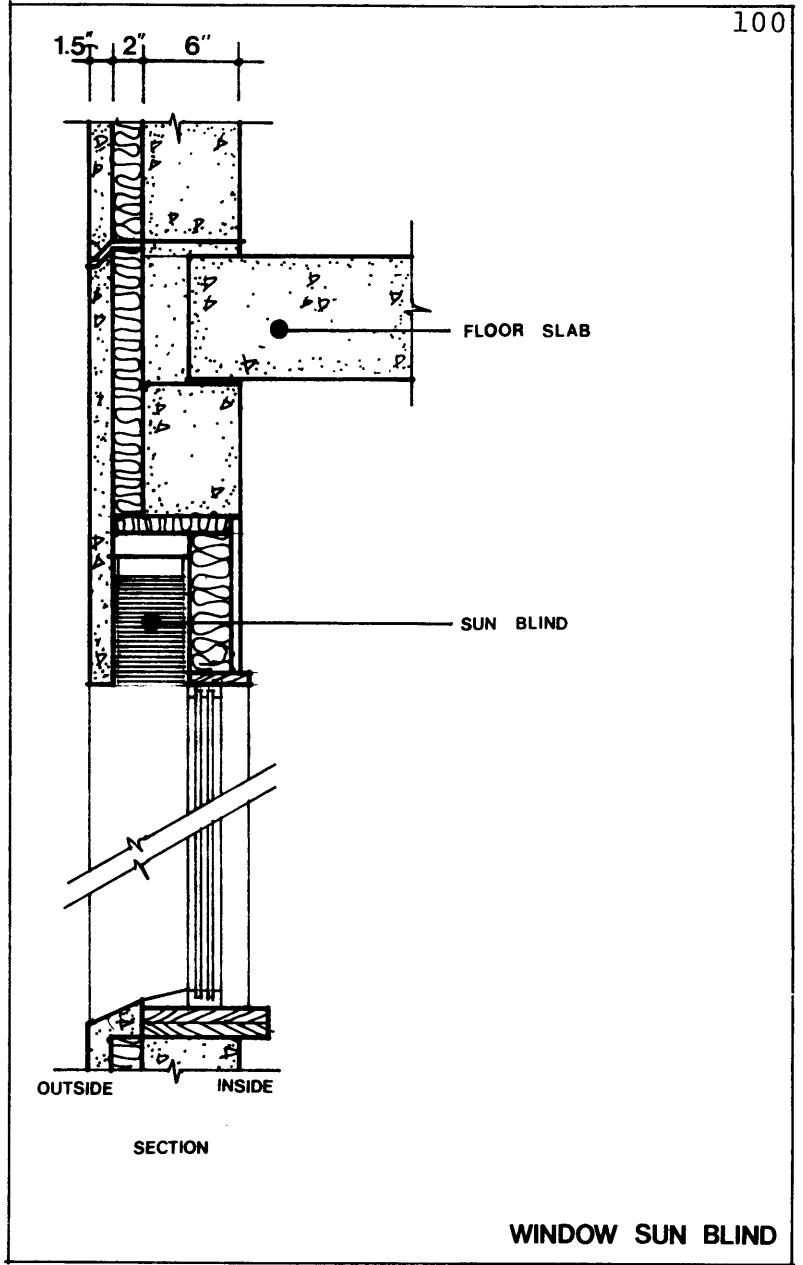
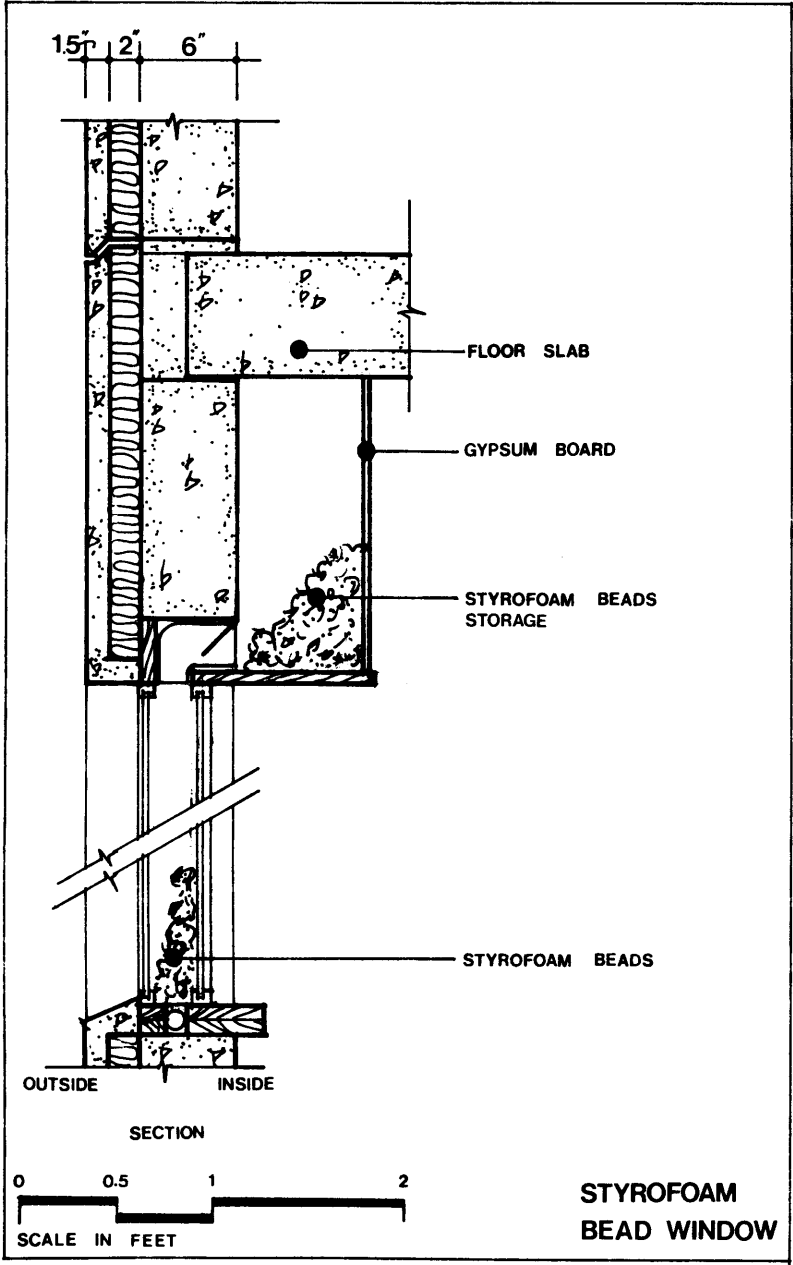

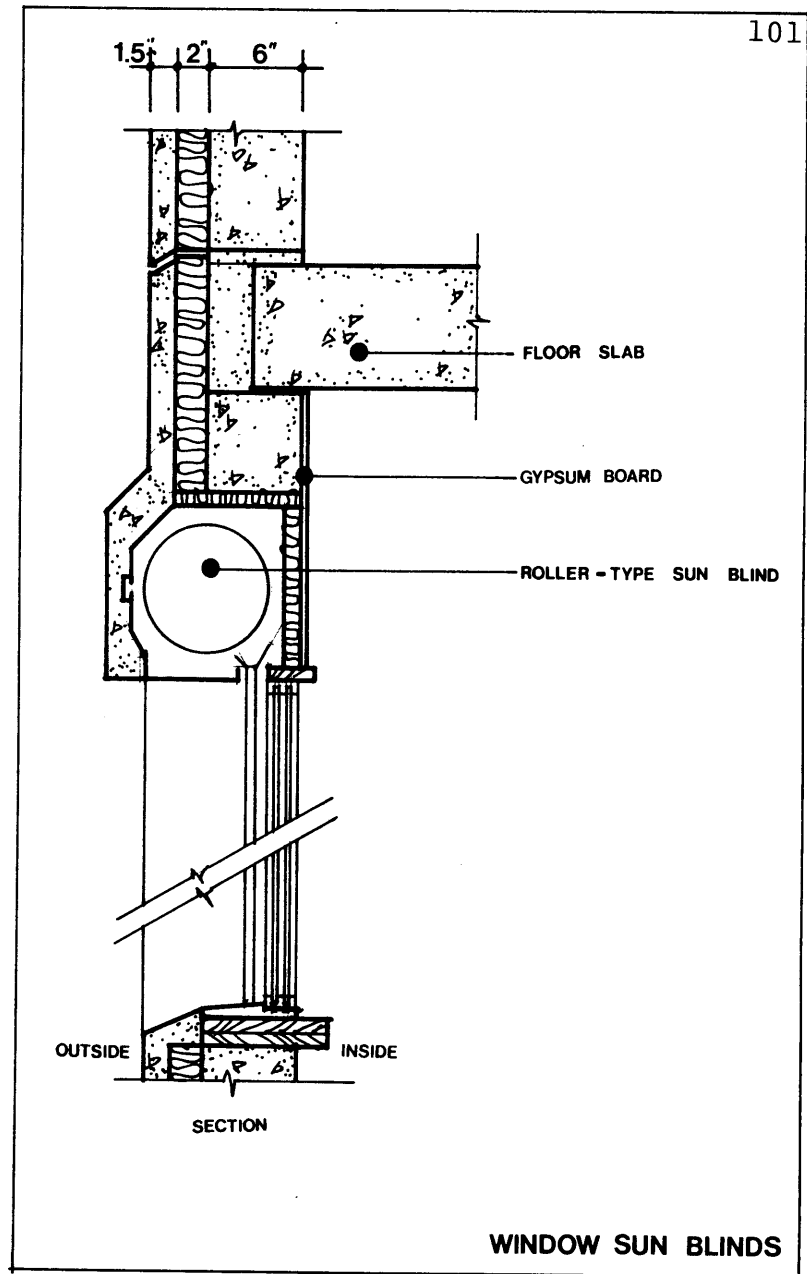
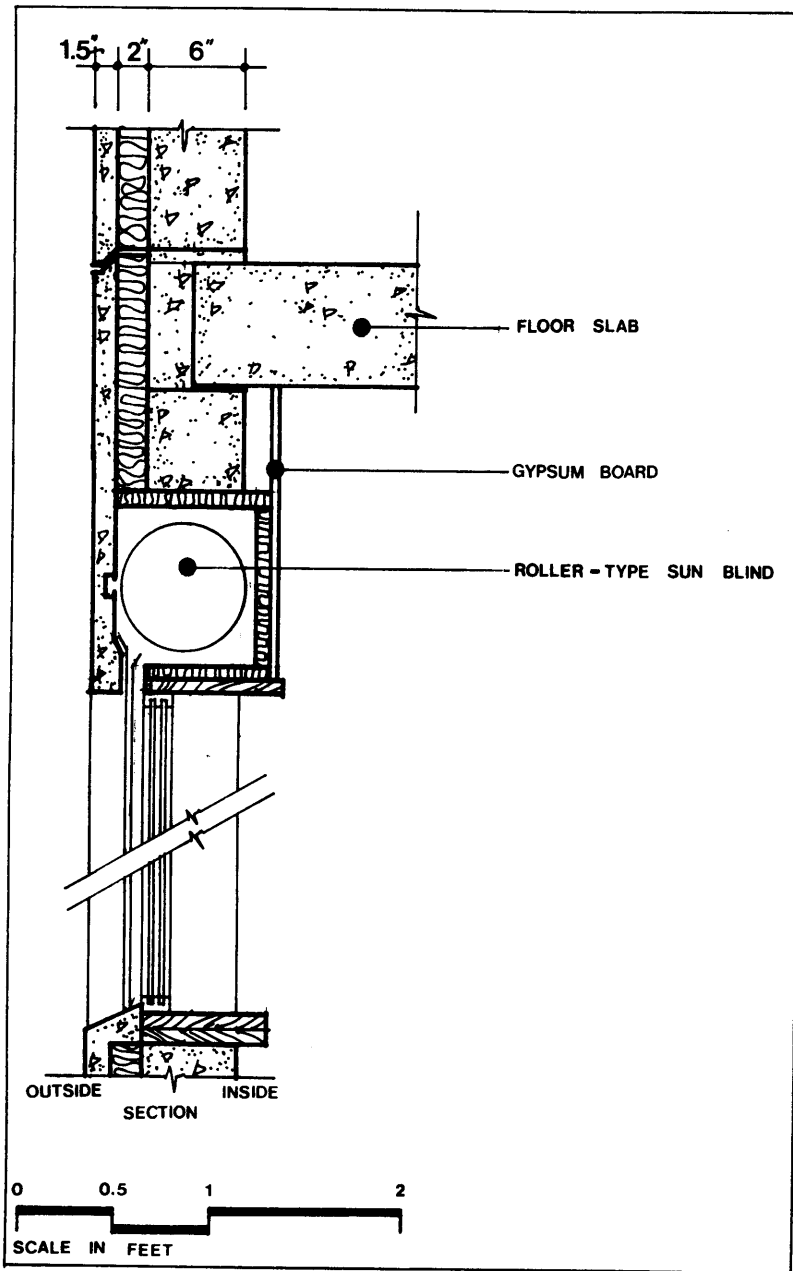

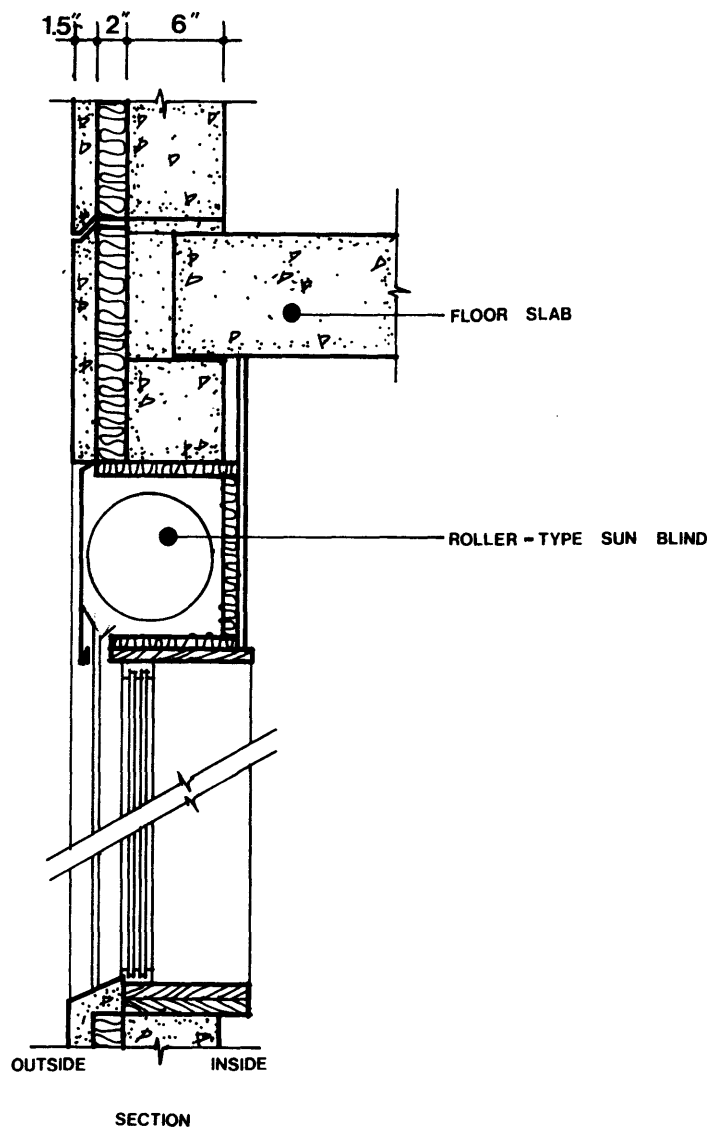
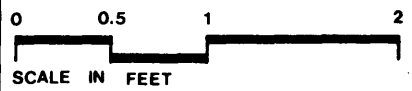
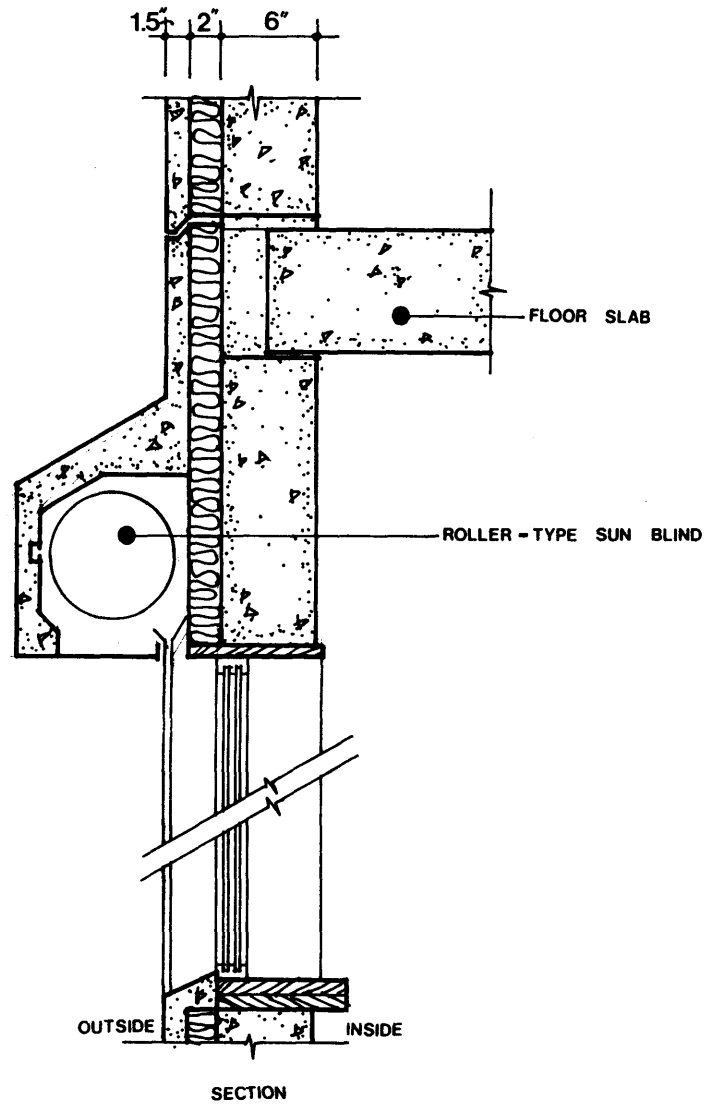

WINDOW SUN BLINDS

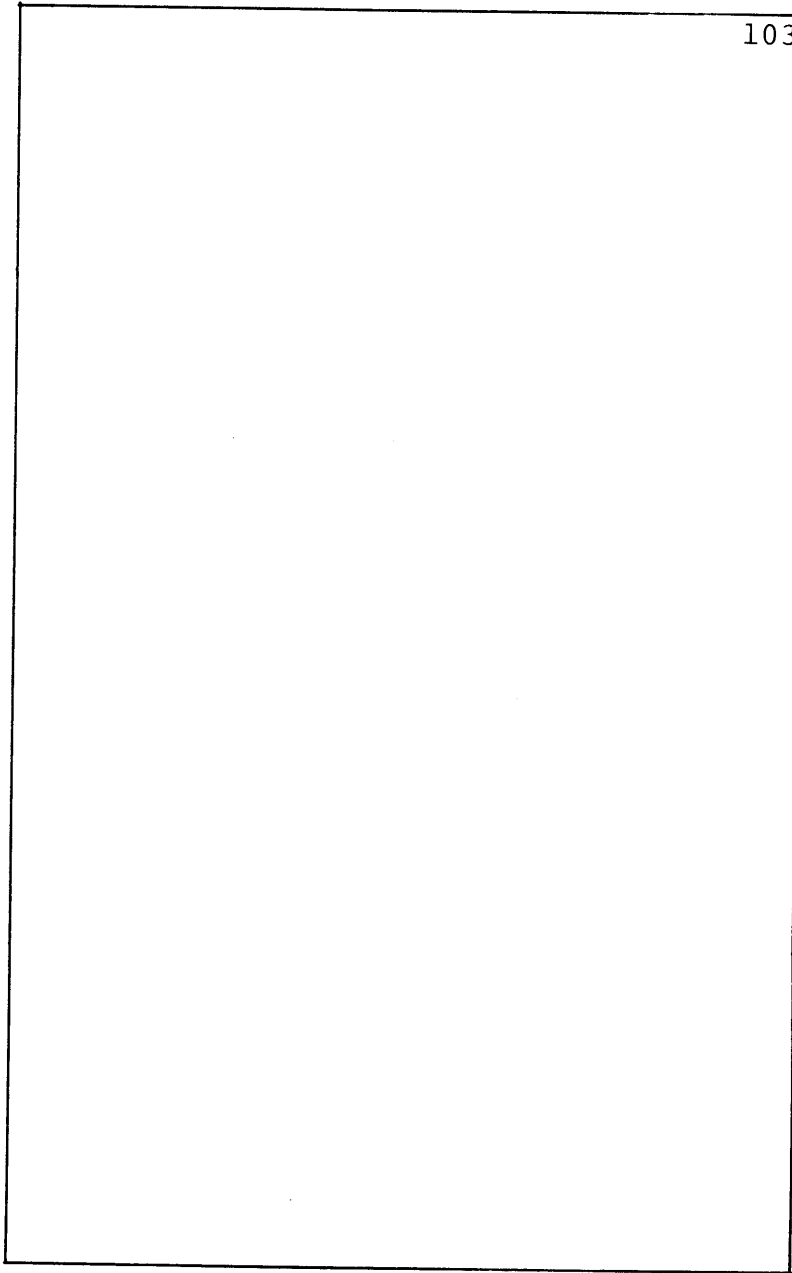
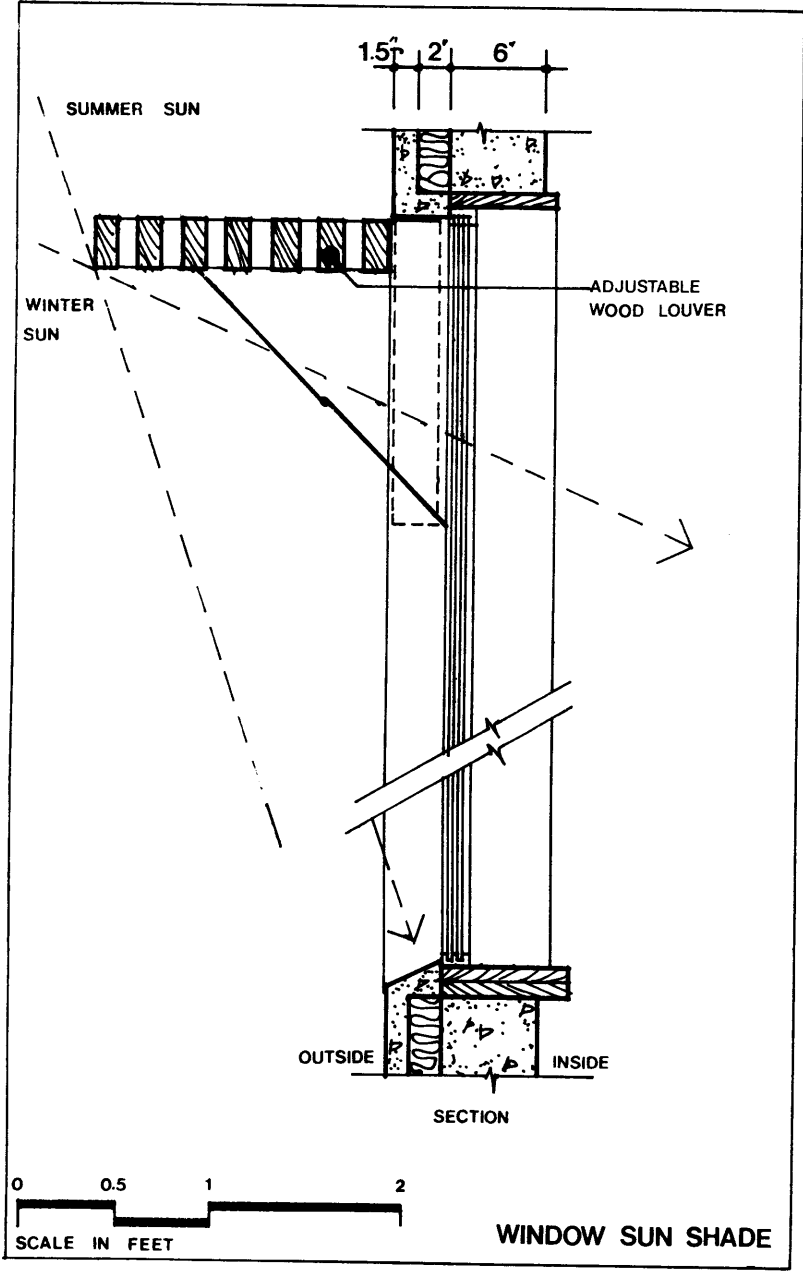

## Roof Sandwich Panels

### Ventilated Roof Components

Roof sandwich panels are composite prefabricates, similar to wall panels. They generally consist of three layers: a structural layer, and two non-structural layers, insulation and roofing material. A number of drawings show the various U values resulting from changing the type and thickness of insulation. For a roof sandwich panel, resistance to heat loss in the winter is equally as important as minimization of heat gain in the summer. Two drawings illustrate ventilated roof components composed of a structural roof and an over-roof. The over-roof prevents solar build-up on the structural roof, while also allowing for the radiated heat to circulate through roof vents.



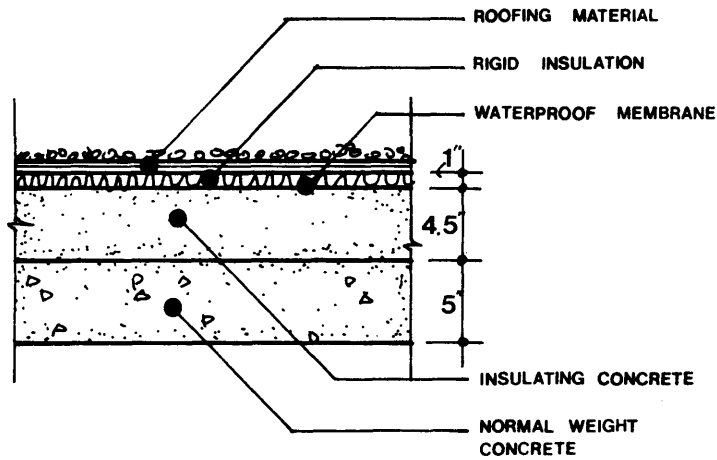

SURFACE FILM (OUTSIDE)	.17
ROOFING MATERIAL	.33
INSULATION	4.00
INSULATING CONCRETE	4.50
CONCRETE	.38
SURFACE FILM (INSIDE)	.68
<b>TOTAL R</b>	<b>10.06</b>
<b>U =</b>	<b>.099</b>

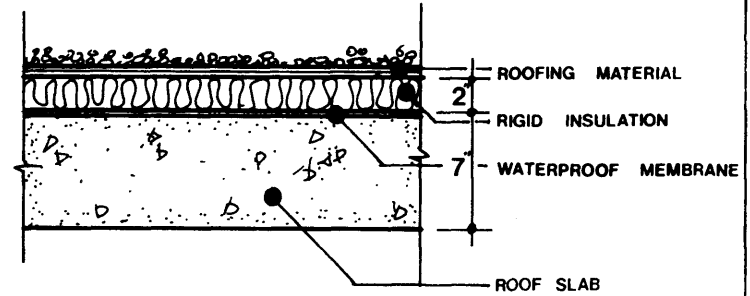
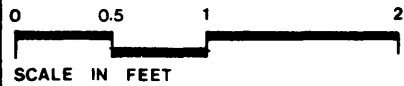

SURFACE FILM (OUTSIDE)	.17
ROOFING MATERIAL	.33
2" POLYURETHANE INSULATION	14.70
7" STRUCTURAL LIGHTWEIGHT CONCRETE	1.33
SURFACE FILM (INSIDE)	.68
<b>TOTAL R</b>	<b>17.21</b>
<b>U =</b>	<b>.058</b>



ROOF SANDWICH PANEL

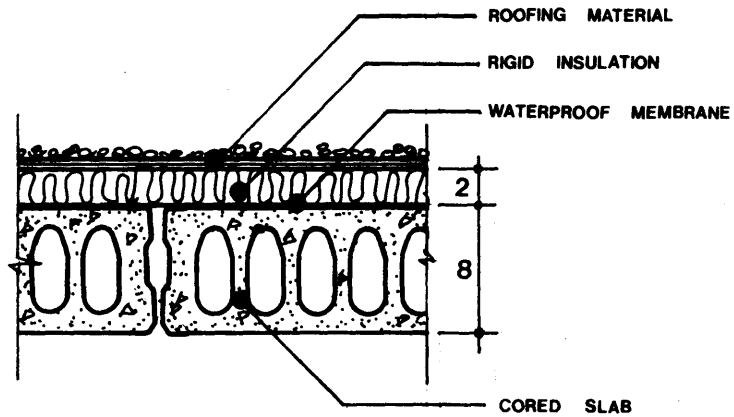

SURFACE FILM (OUTSIDE)	.17
ROOFING MATERIAL	.33
2" POLYURETHANE INSULATION	14.70
CORED SLAB	3.00
SURFACE FILM (INSIDE)	.68
	<hr/>
<b>TOTAL R</b>	<b>18.88</b>
<b>U =</b>	<b>.053</b>



**ROOF SANDWICH PANEL**

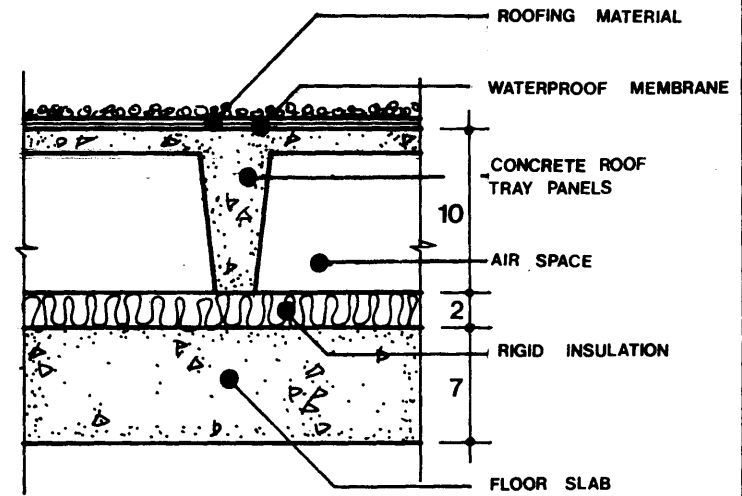

**VENTILATED ROOF COMPONENTS**

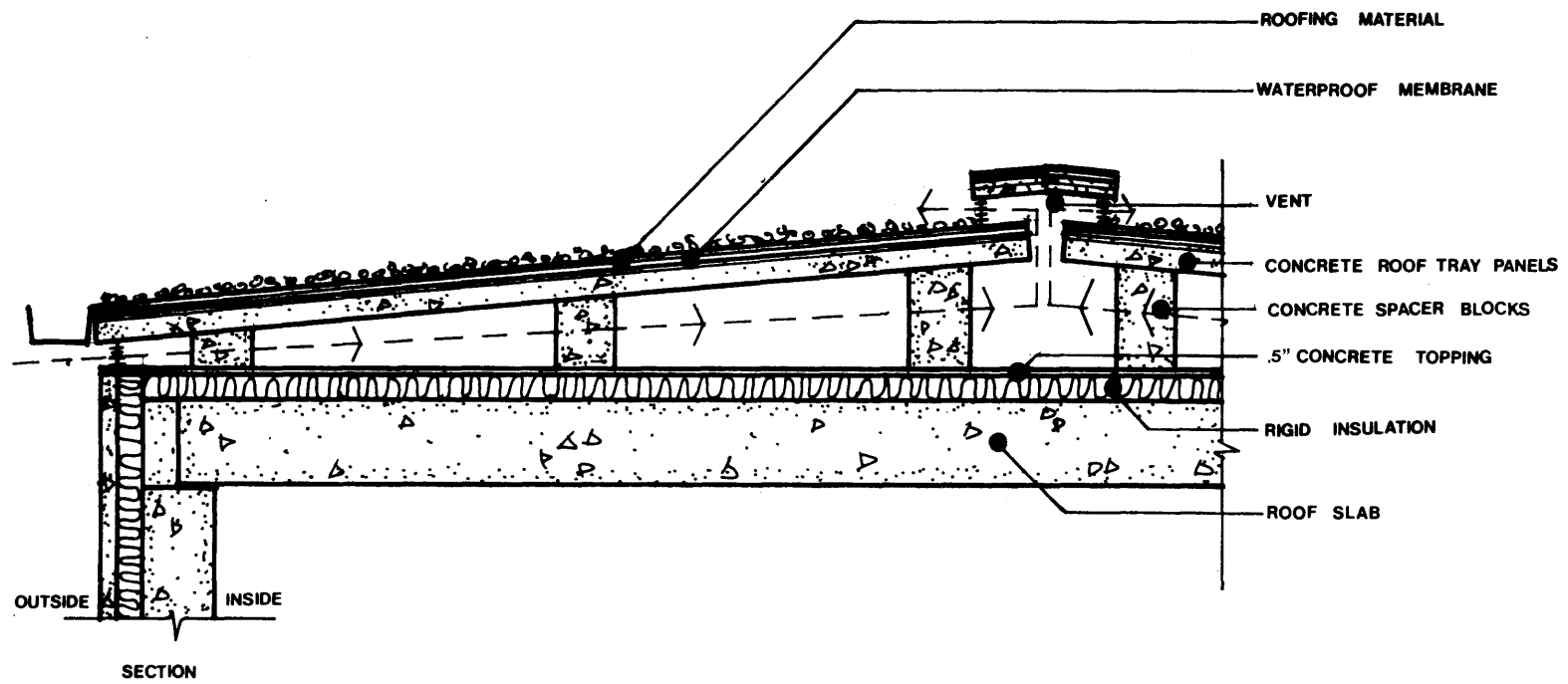

VENTILATED ROOF COMPONENTS

Trombe Wall Panels  
Greenhouse Components

The last drawings of this section show industrialized components which incorporate passive solar/energy conservation concepts in their design. Trombe wall panels are created by using cored slabs as floor structure with homogeneous concrete wall panels. The homogeneous wall panels collect store and radiate solar heat to the interior, while the cored slabs carry heated air to the interior spaces by natural currents.

A sunspace can be added to a housing system by bolting a prefabricated greenhouse onto the existing roof of the structure below. Solar heat and humidity are added to living space by opening a door. Overheating is prevented by separating

the greenhouse from the interior space by a wall sandwich panel.

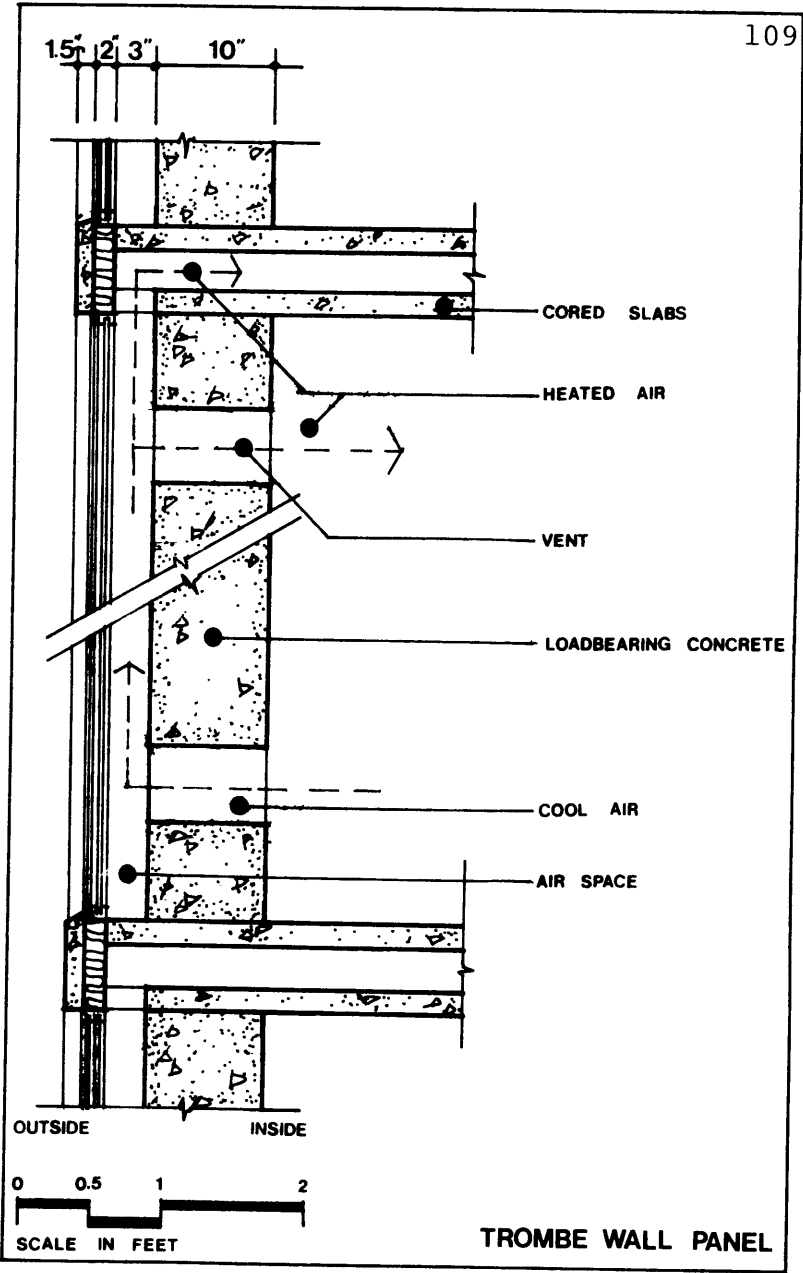
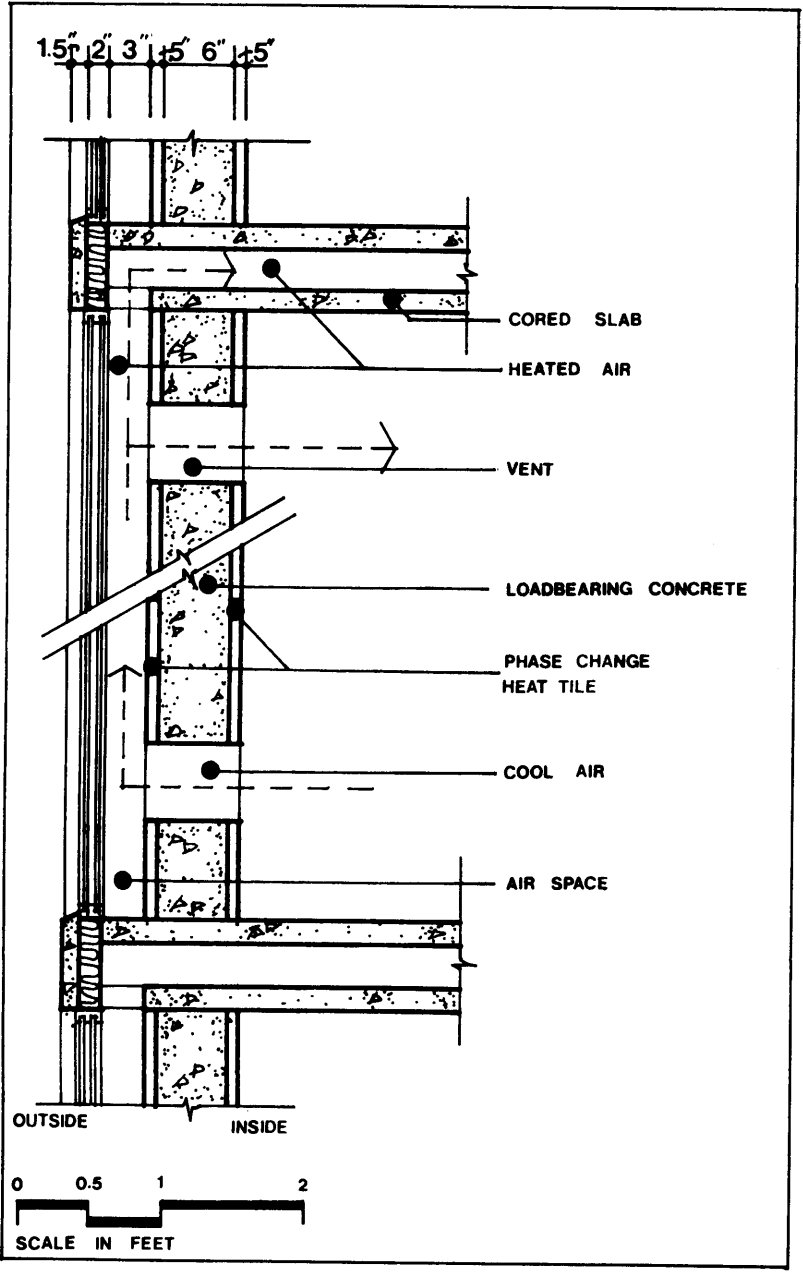

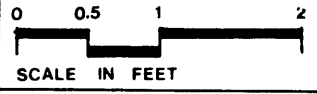
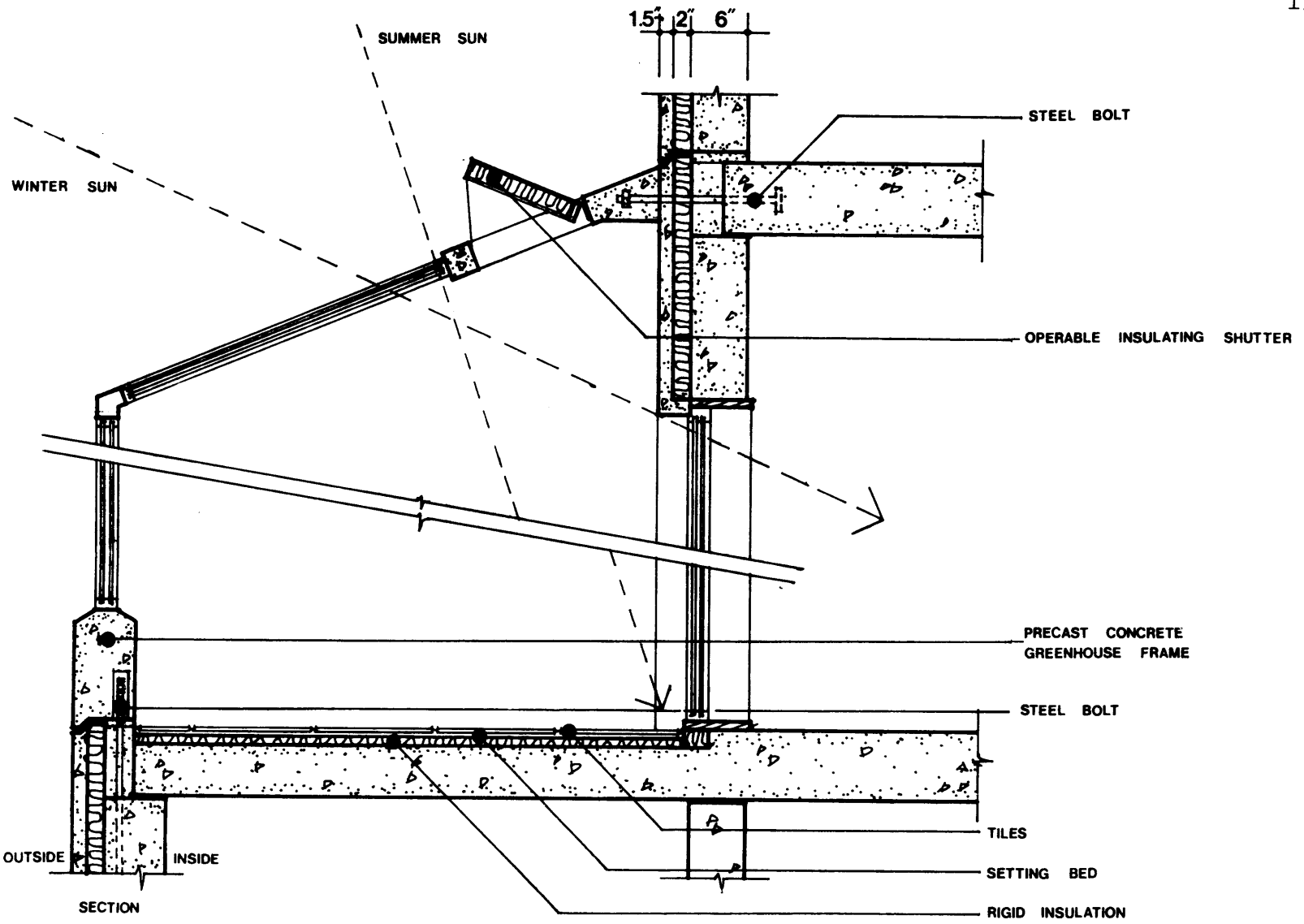

GREENHOUSE COMPONENTS

**PROTOTYPE**

## PROTOTYPE

### I. Energy Conscious Design Elements

Based on the concepts illustrated in the preceding chapters, an industrialized housing system in precast concrete has been developed. The climactic region chosen for the prototype is the Boston area and the site would be in a suburban community.

To maximize solar gains, the housing system is oriented on the east/west axis at  $12^{\circ}$  east of south. Entrances and corridors are located on the northern exposure to create a buffer zone from the winter northwestern winds. Evergreen trees on the north also create a wind break. All living spaces have exposure on the south, southeast, southwest, east, or west exposures. The individual units are

passively solar heated by direct solar gain through windows on these exposures, and by indirect solar gain through mass trombe walls and greenhouses. The buildings are spaced the distance required to allow full solar exposure for the south orientation in winter.

Sunshading is provided in the summer by deciduous trees on the south, east, and west exposures, and by sunshades and shutters.



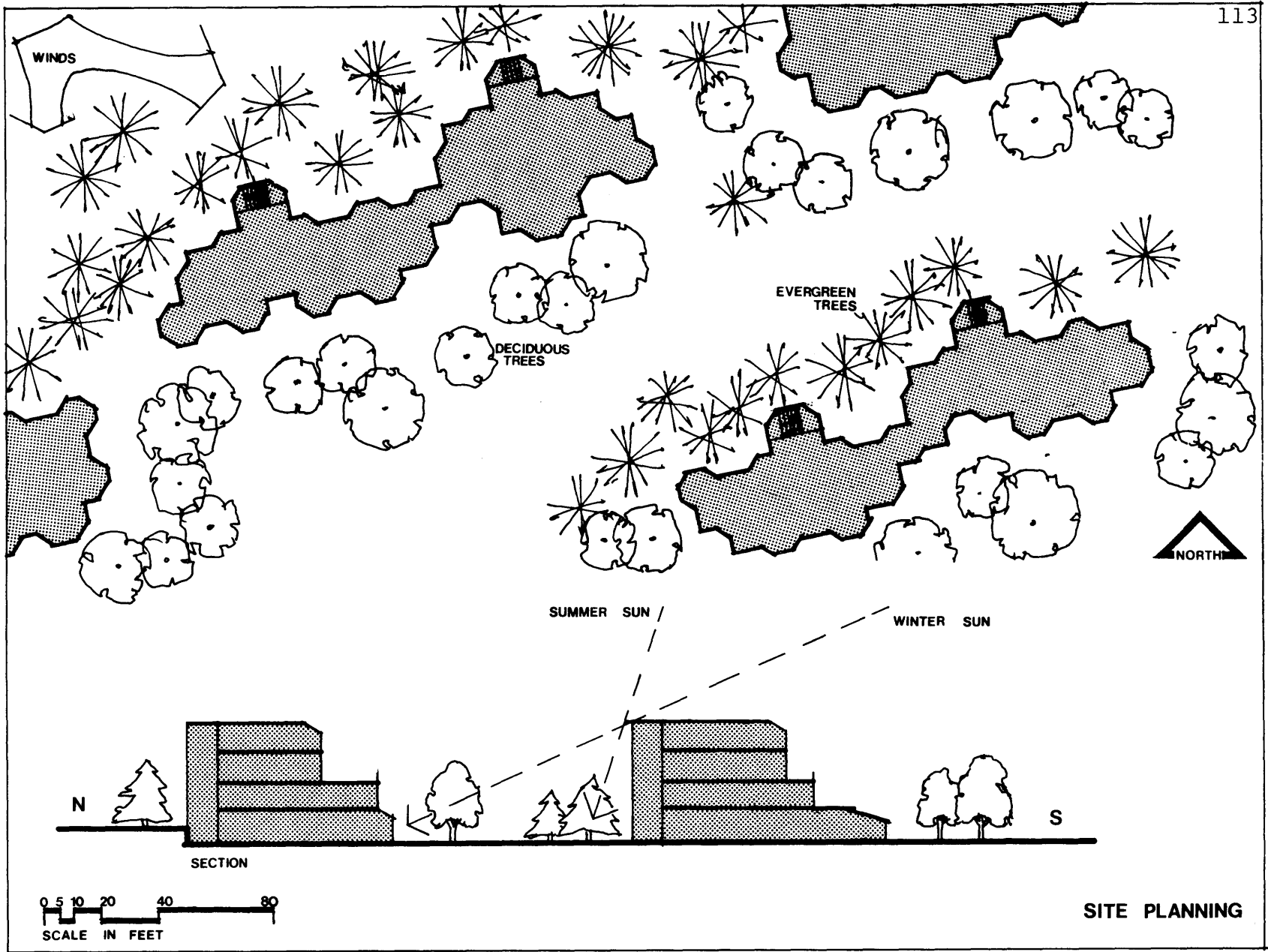

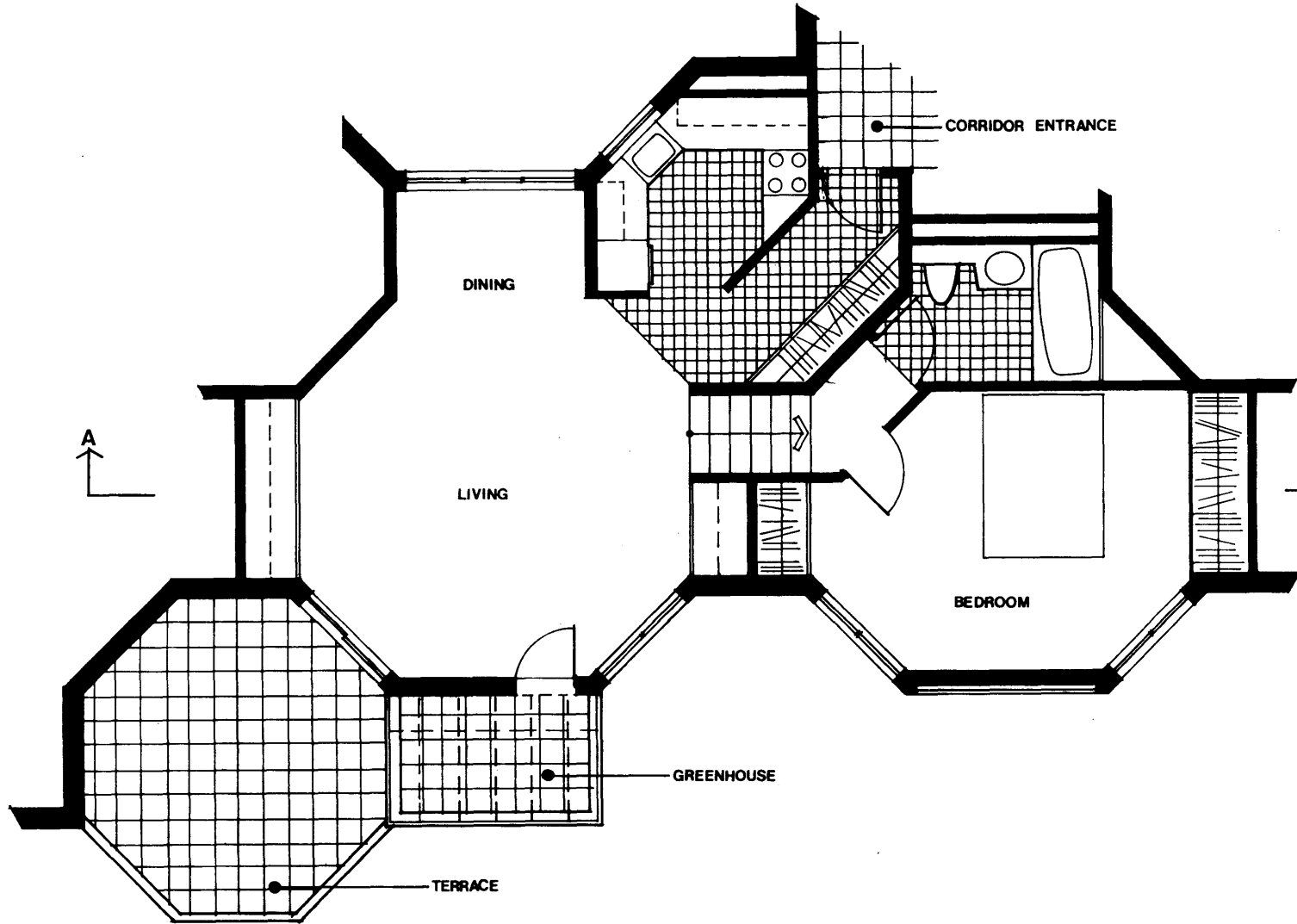

728sq.ft.



B1 ONE BEDROOM UNIT

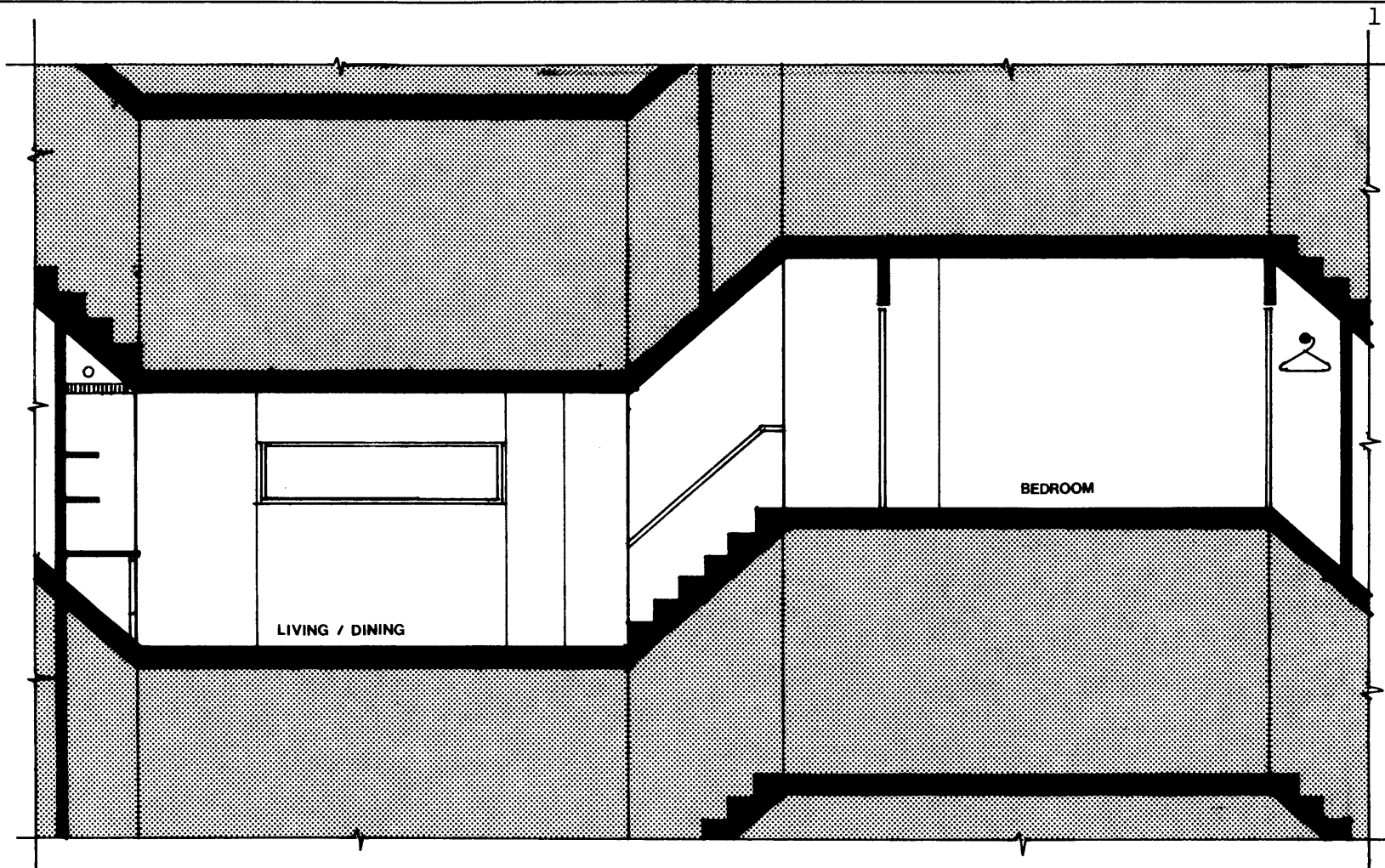

SECTION A - A

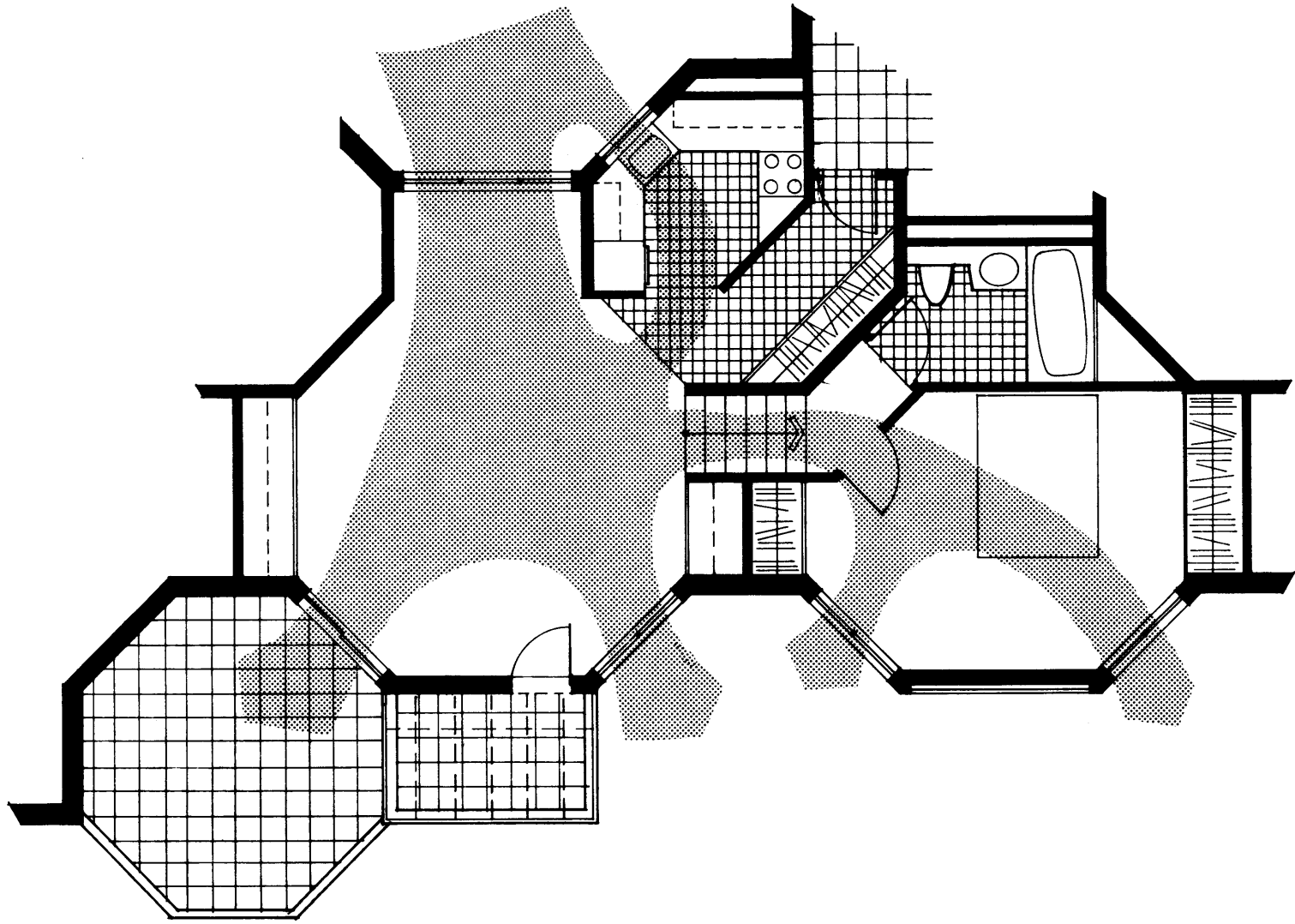

CROSS - VENTILATION

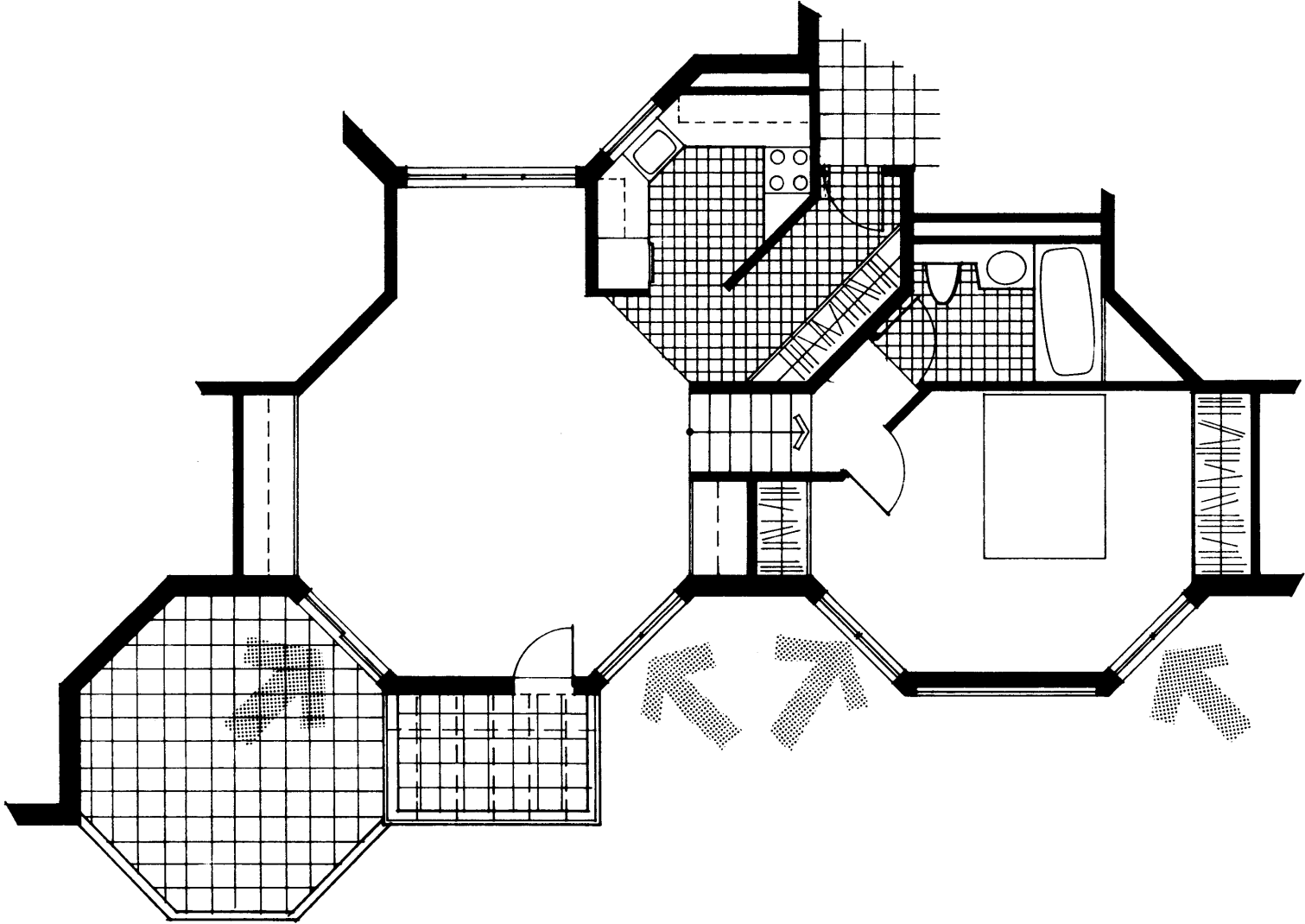

DIRECT GAIN THROUGH GLAZING

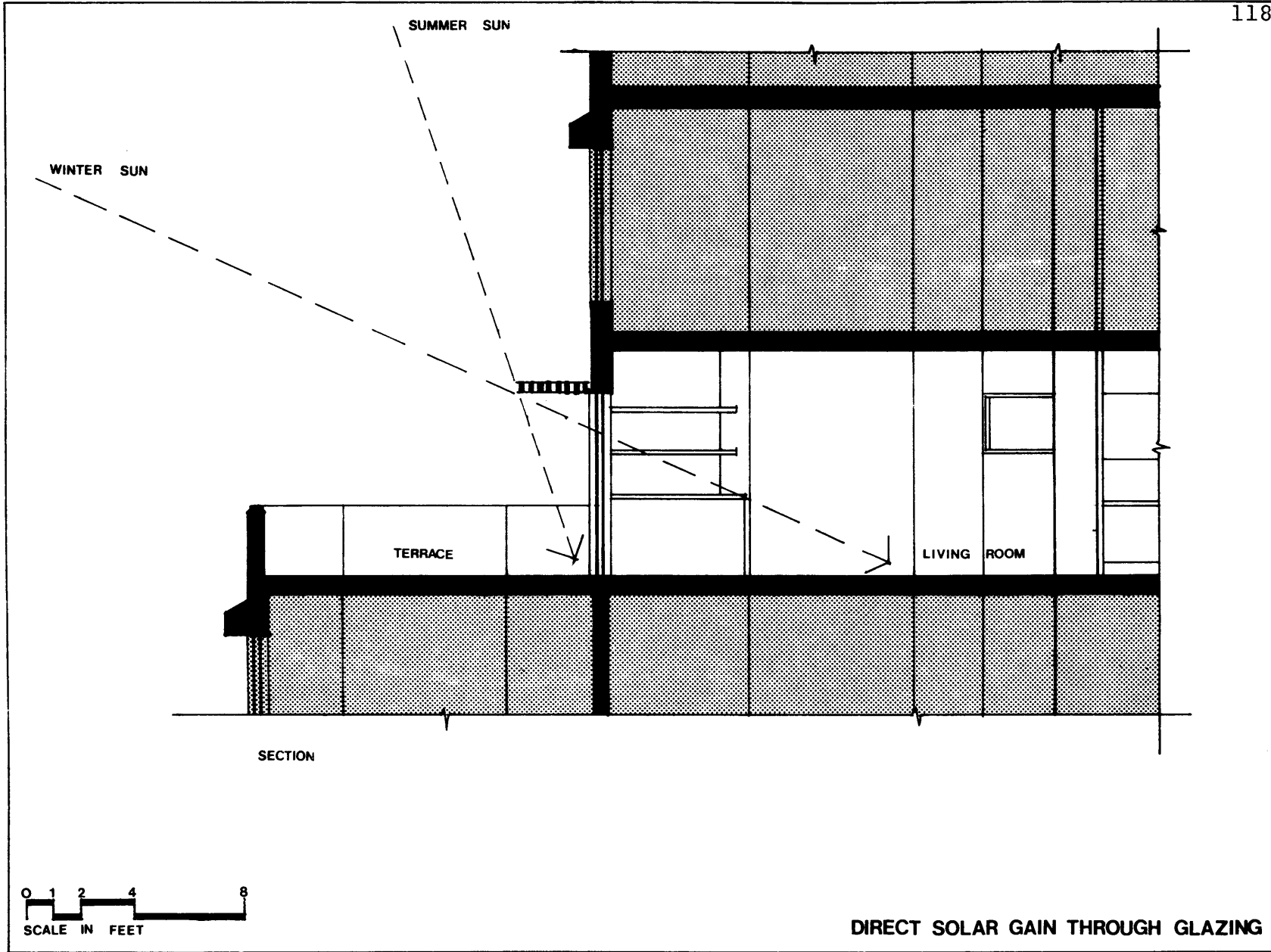

DIRECT SOLAR GAIN THROUGH GLAZING

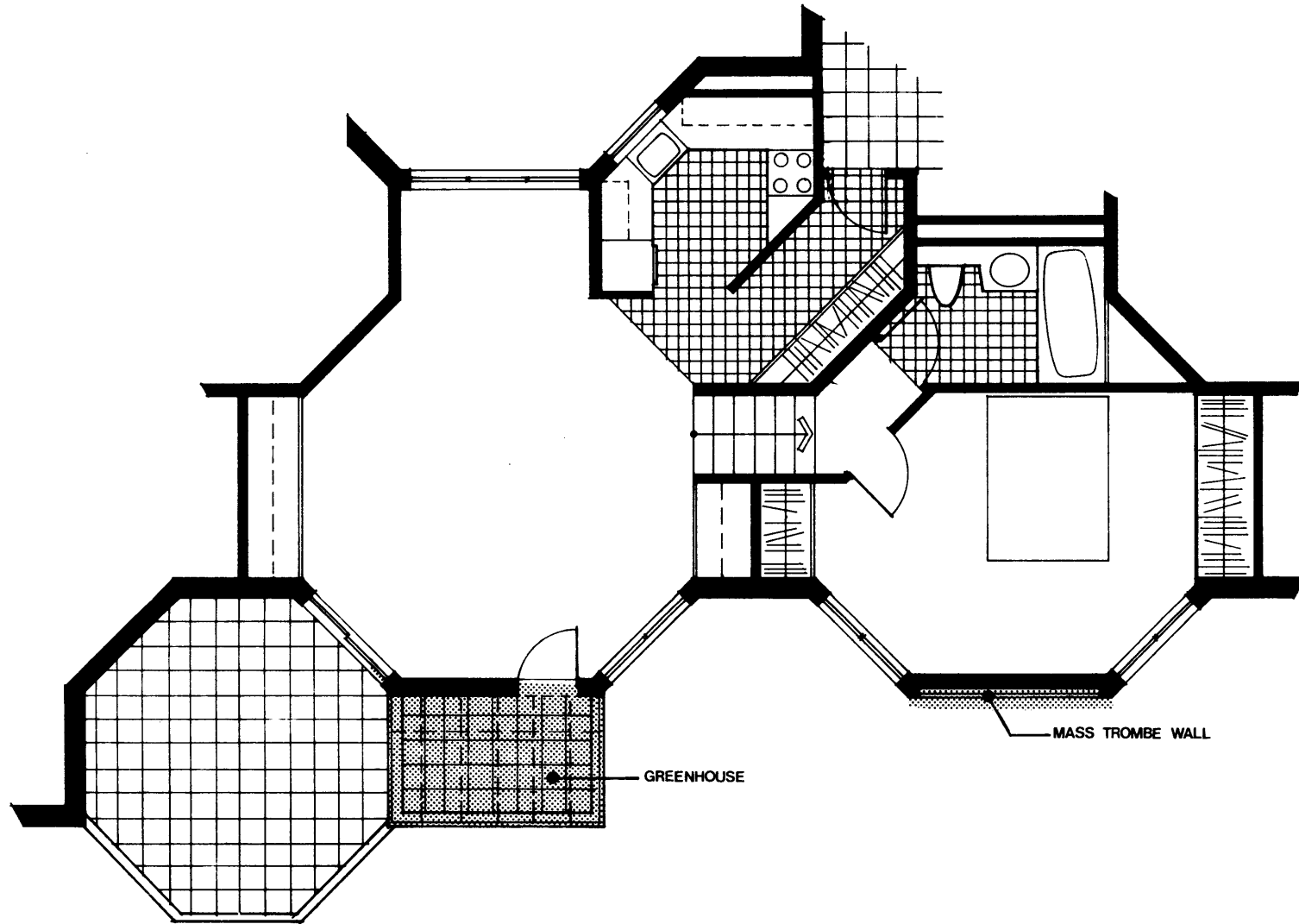

PASSIVE SOLAR COLLECTION & STORAGE

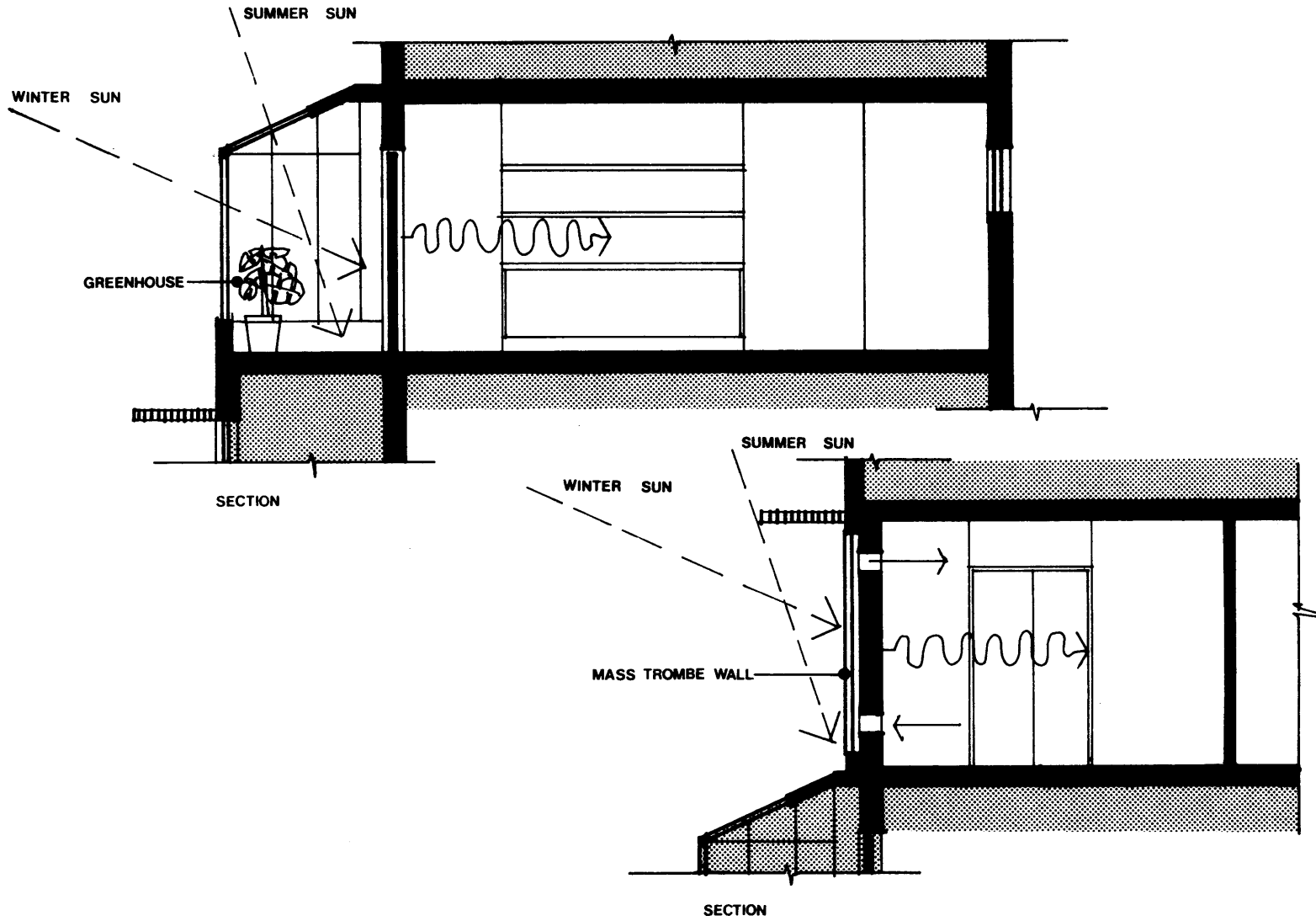

PASSIVE SOLAR COLLECTION & STORAGE



## II. Industrialized Components

The housing system is constructed of loadbearing walls and floor panels. The components consist of exterior loadbearing panels of composite prefabricates, interior loadbearing panels of homogeneous prefabricates, and floor panels of homogeneous prefabricates.

The wall sandwich panels consist of three layers: a structural concrete layer and two non-structural layers, insulation and exterior concrete. The homogeneous panels are concrete. The floor panels are monolithic concrete cross-reinforced panels supported on the corners and edges by the loadbearing panels. The reinforced concrete slabs are two-way slabs.

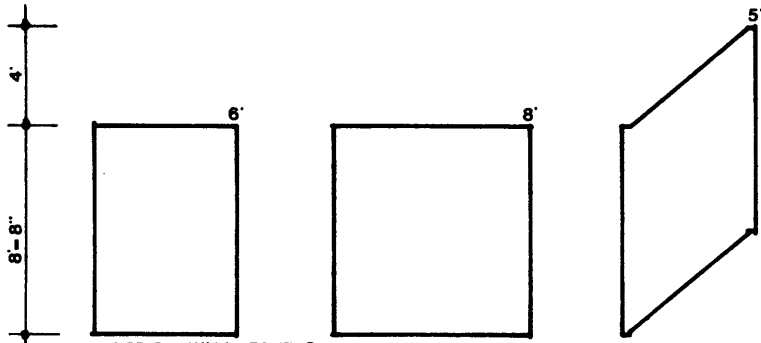

INTERIOR WALL PANELS

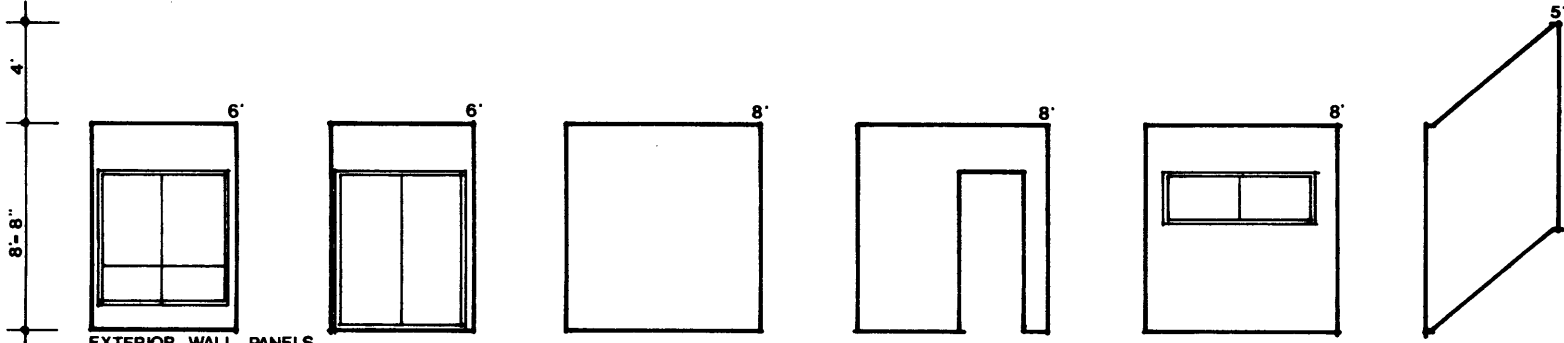

EXTERIOR WALL PANELS

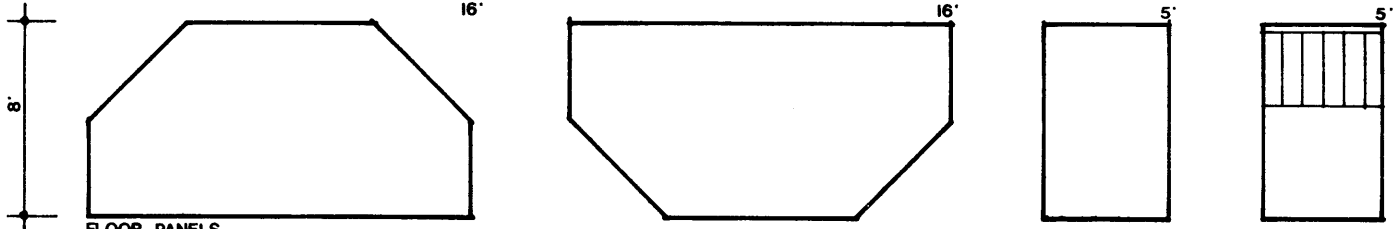

FLOOR PANELS

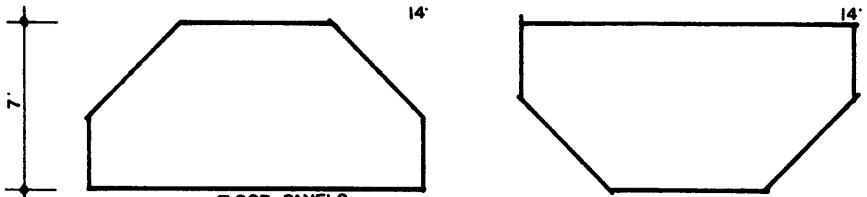

FLOOR PANELS



INDUSTRIALIZED COMPONENTS

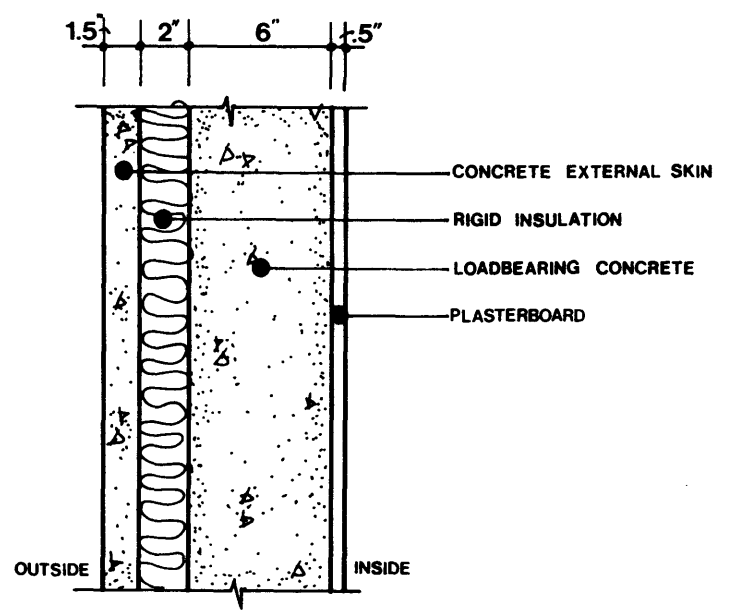

SURFACE FILM (OUTSIDE)	.17
7.5" STRUCTURAL LIGHTWEIGHT CONCRETE	1.43
2" POLYURETHANE INSULATION	14.70
.5" PLASTERBOARD	.45
SURFACE FILM (INSIDE)	.68
<hr/>	
<b>TOTAL R</b>	<b>17.43</b>
<b>U =</b>	<b>.057</b>

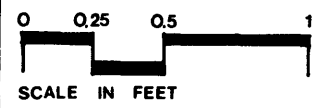

**EXTERIOR  
LOADBEARING WALL**

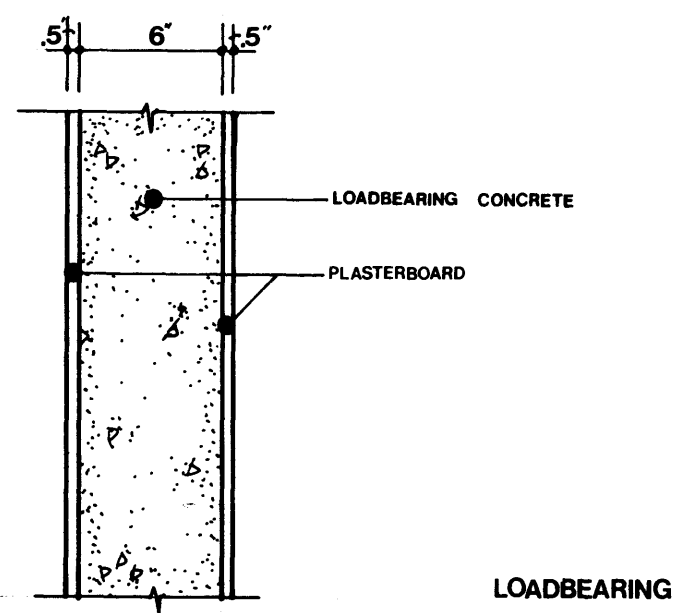

**LOADBEARING**

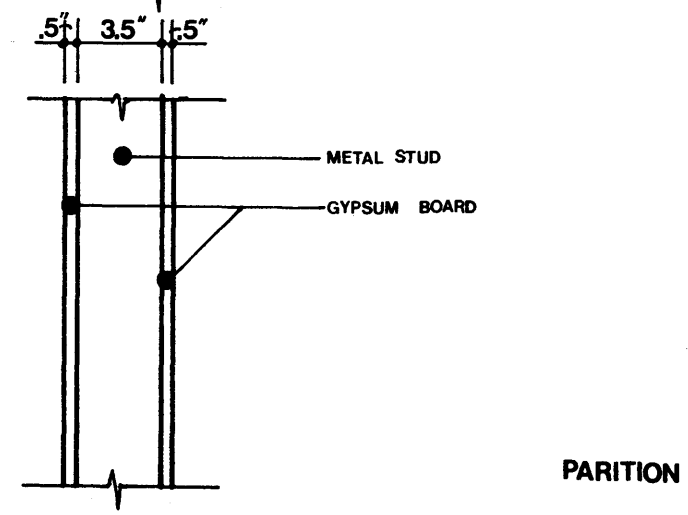

**PARTITION**

**INTERIOR WALLS**

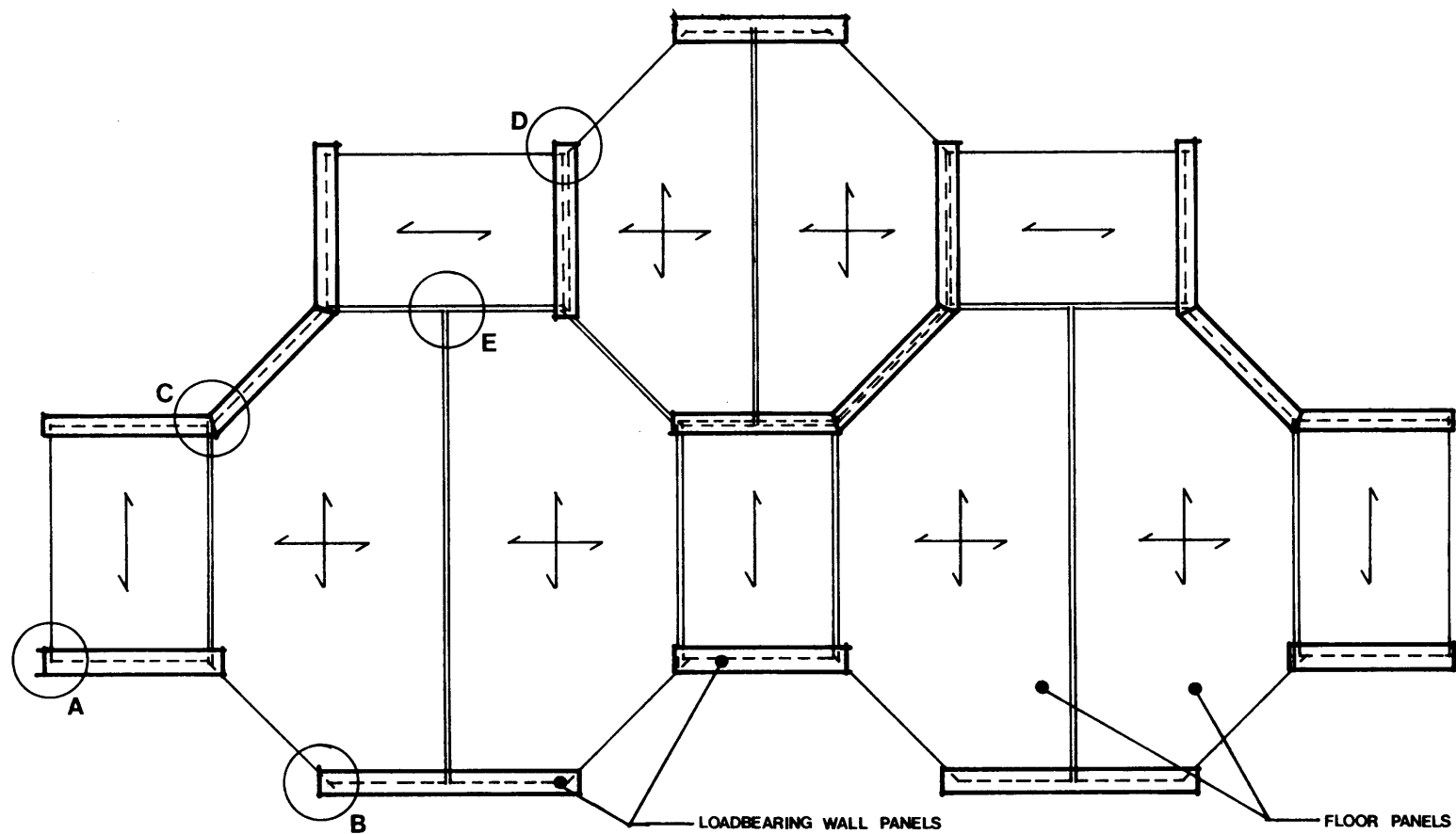

STRUCTURAL SYSTEM

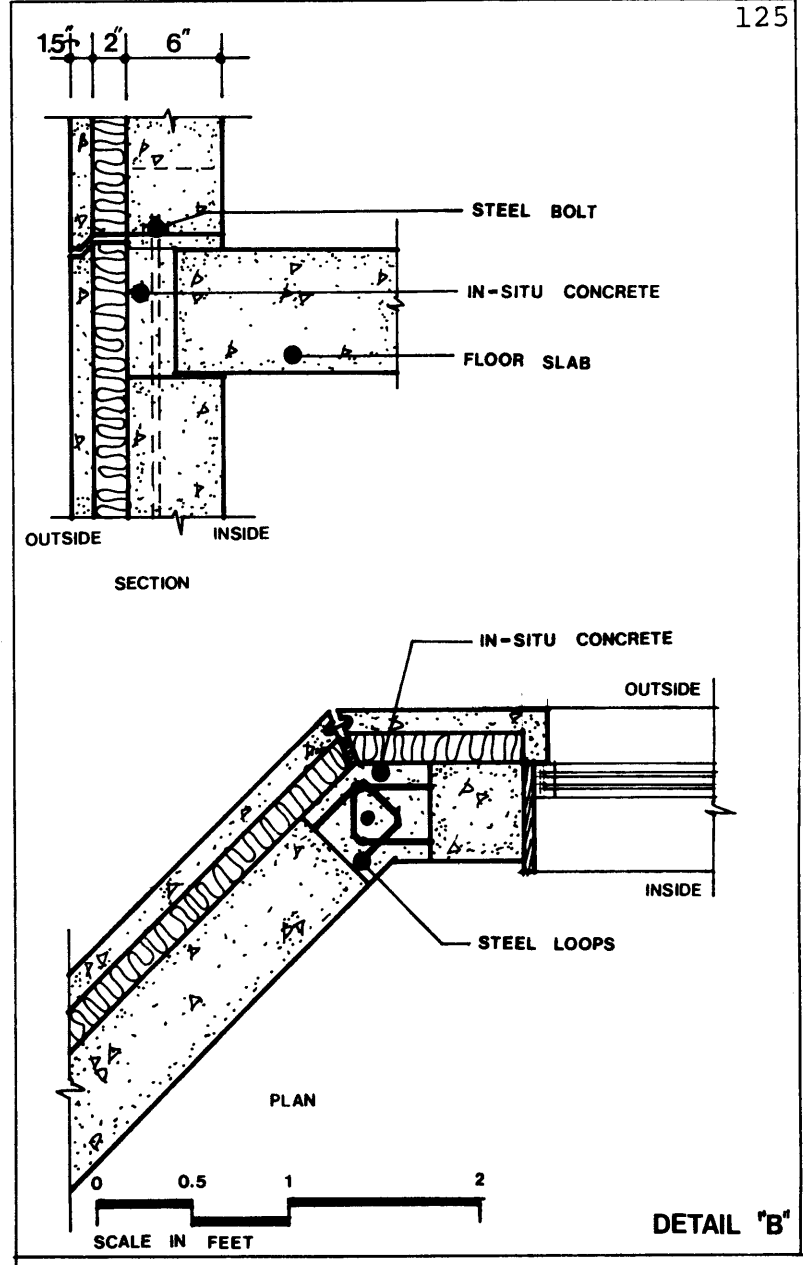
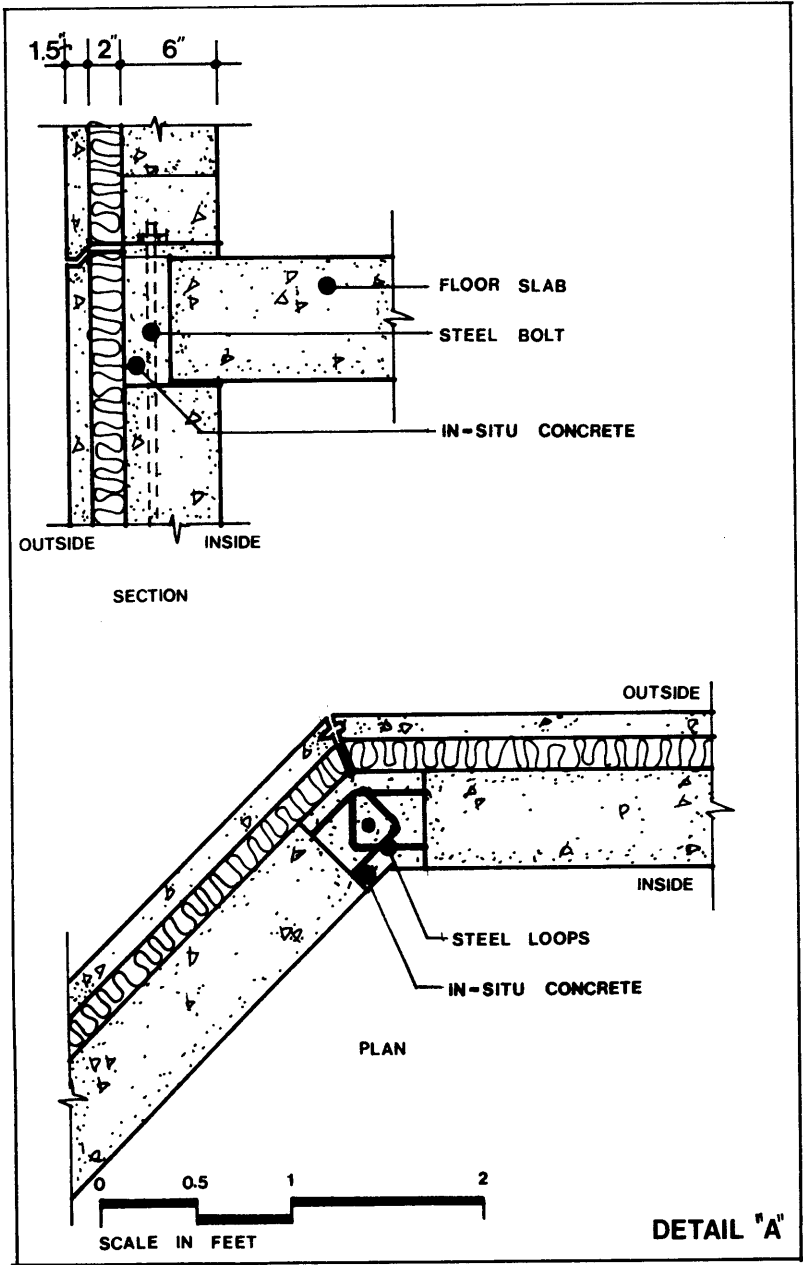

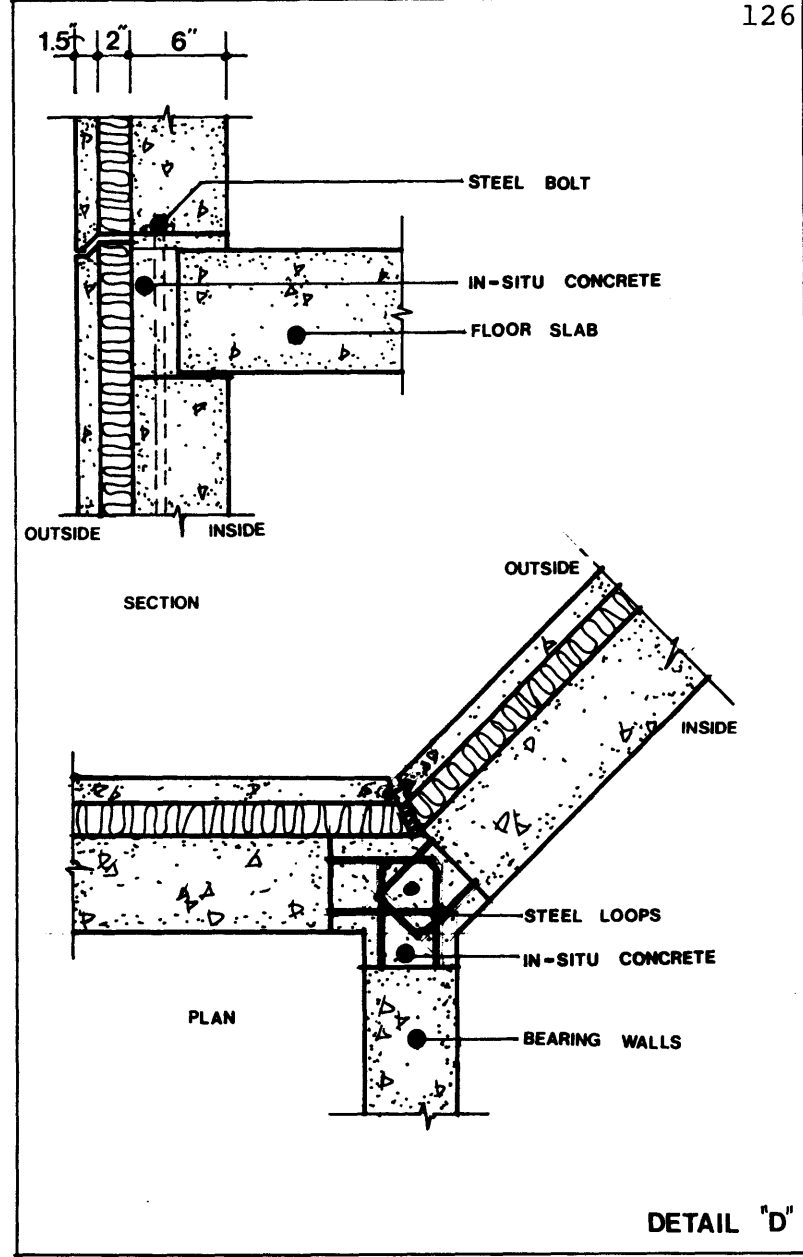
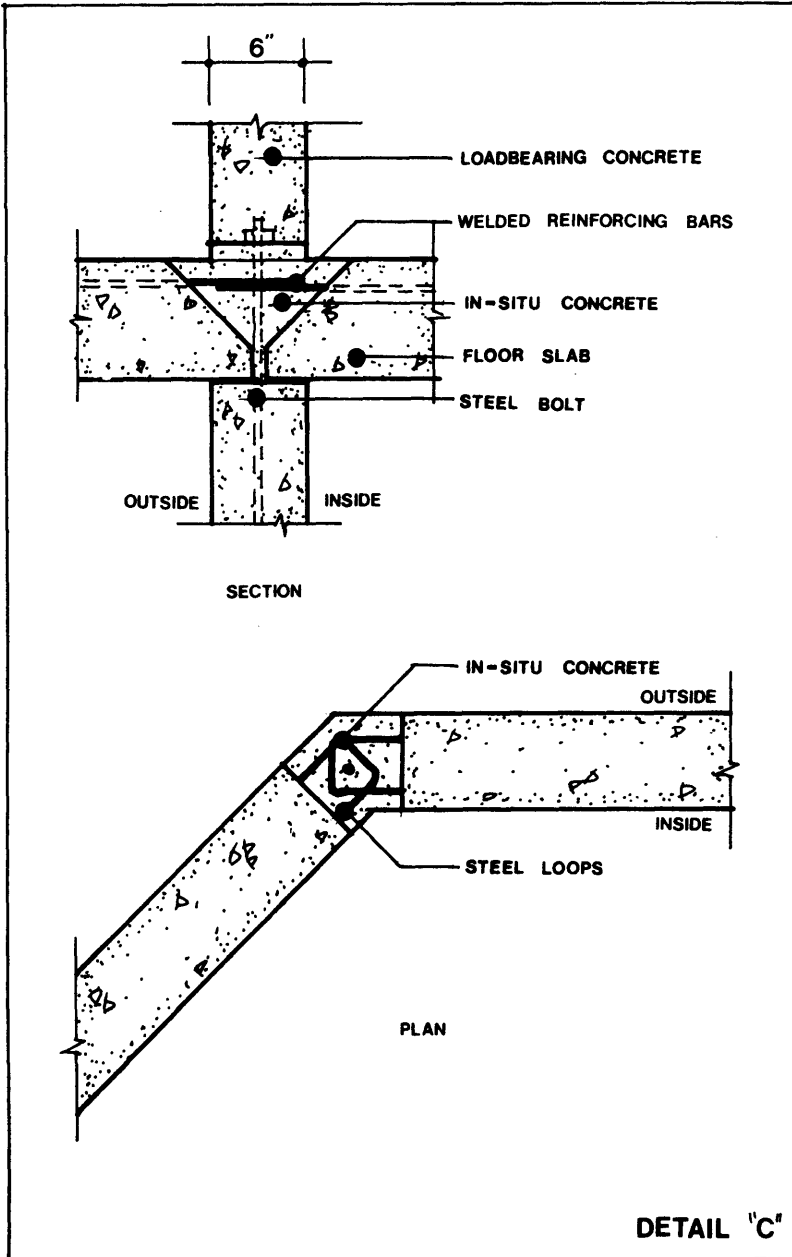

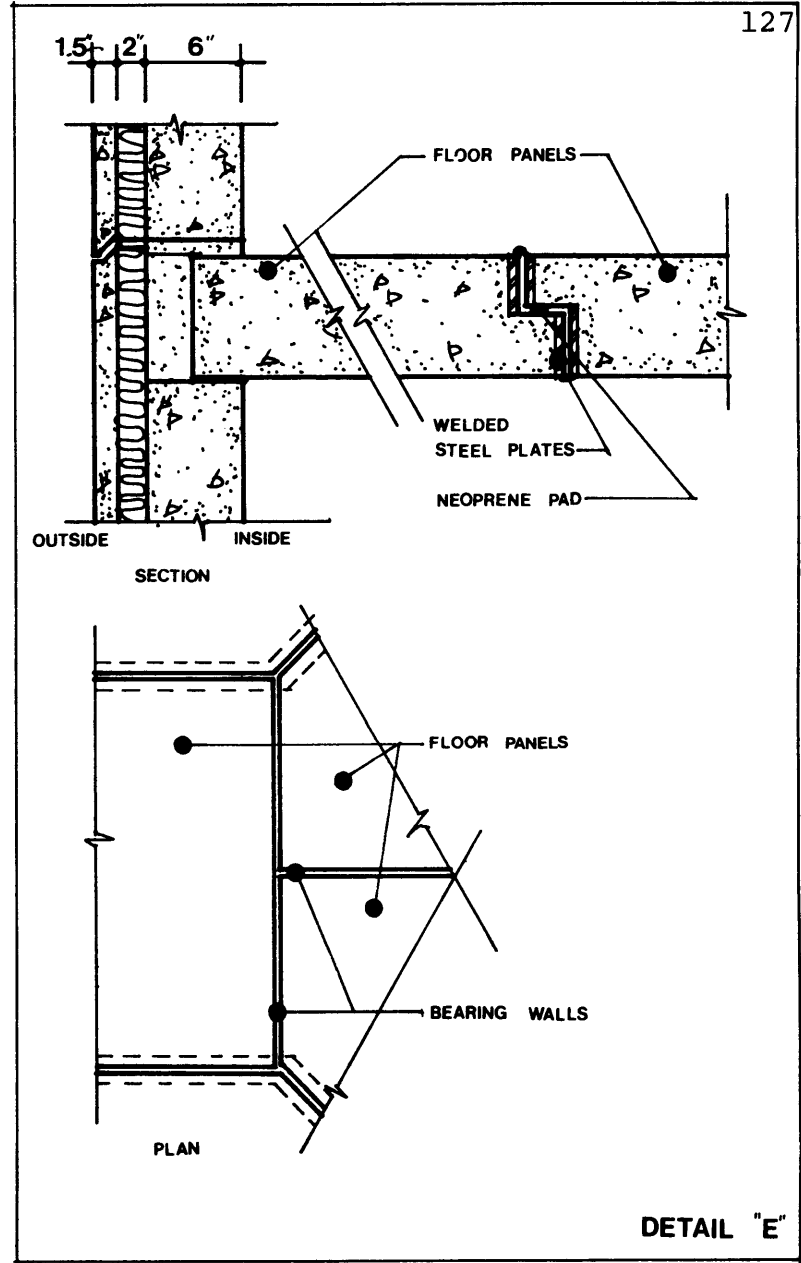
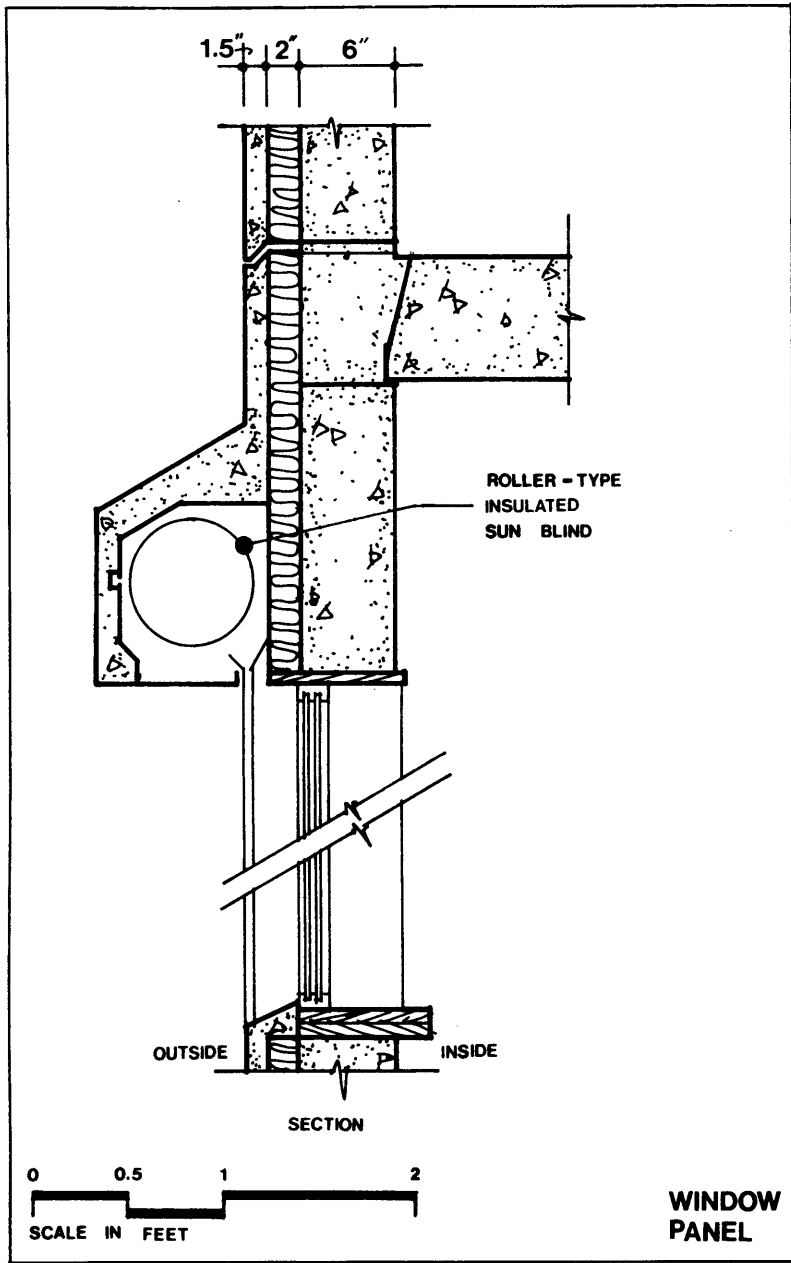

### III. Housing System

A housing system was assembled from the previously described components into varied geometric configurations. A non-orthogonal geometry was explored to try to provide more freedom in interior planning and a greater variety in unit groupings. The geometry provides fluidity in building shapes, flexibility in building configuration and adaption to site limitations. The variety of orientations of the multiple-faceted units allow for increased solar gain, and greater opportunity for cross-ventilation.

By increasing the number of building orientations from four to eight, solar gain is increased by providing more opportunities for glazing. In most individual units, direct solar gain occurs on

the southeast and southwest orientations, while solar storage elements, such as greenhouses and mass trombe walls are located on the southern exposure. The increased orientations also allow for natural ventilation from the north to south, northwest to southeast, northeast to southwest, and east to west directions.

The non-orthogonal geometry also provides variety in the individual units by the change of level between entrance and living/dining space, or between living/dining space and bedrooms. The change of level is 1/2 story and occurs throughout the housing system.



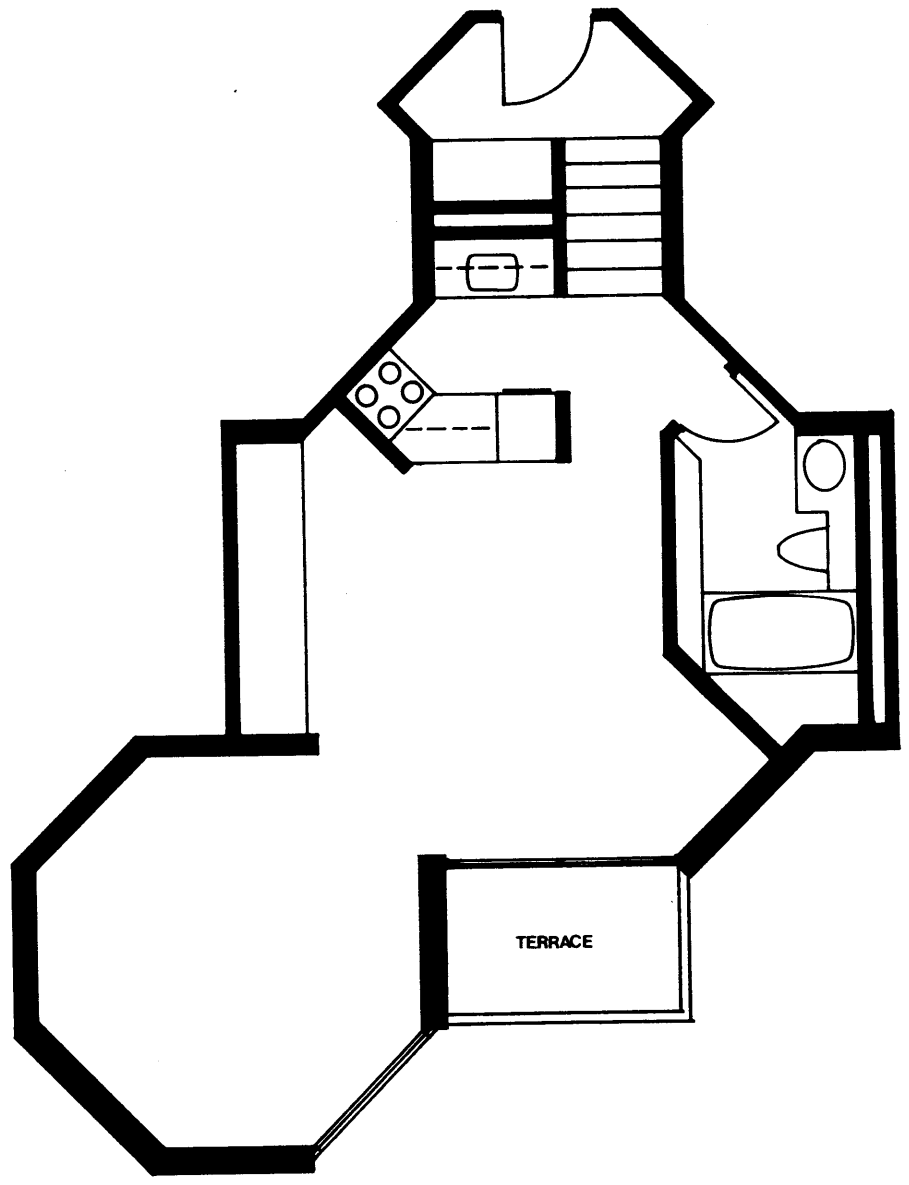

510sq.ft.



SCALE IN FEET



A1 STUDIO UNIT

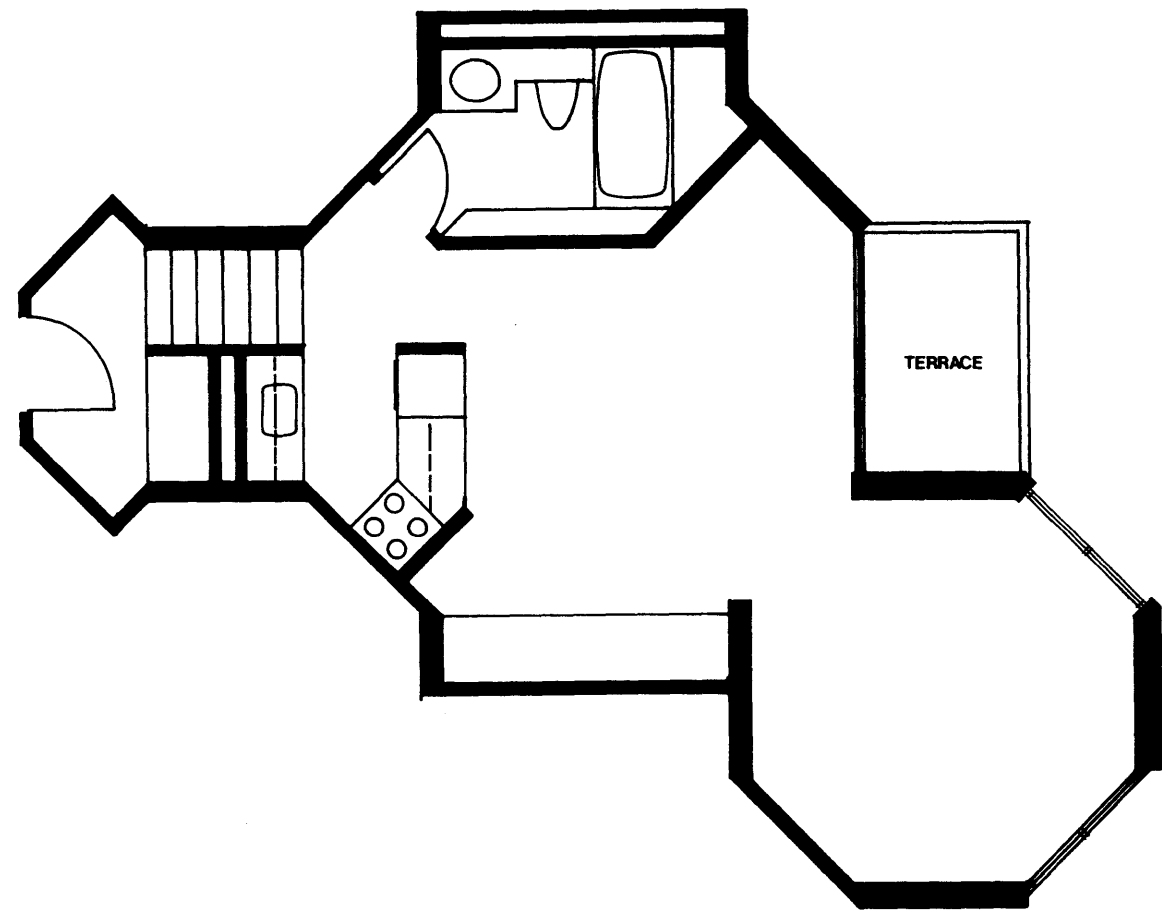

510 sq.ft.  
0 1 2 4 8  
SCALE IN FEET



A2 STUDIO UNIT

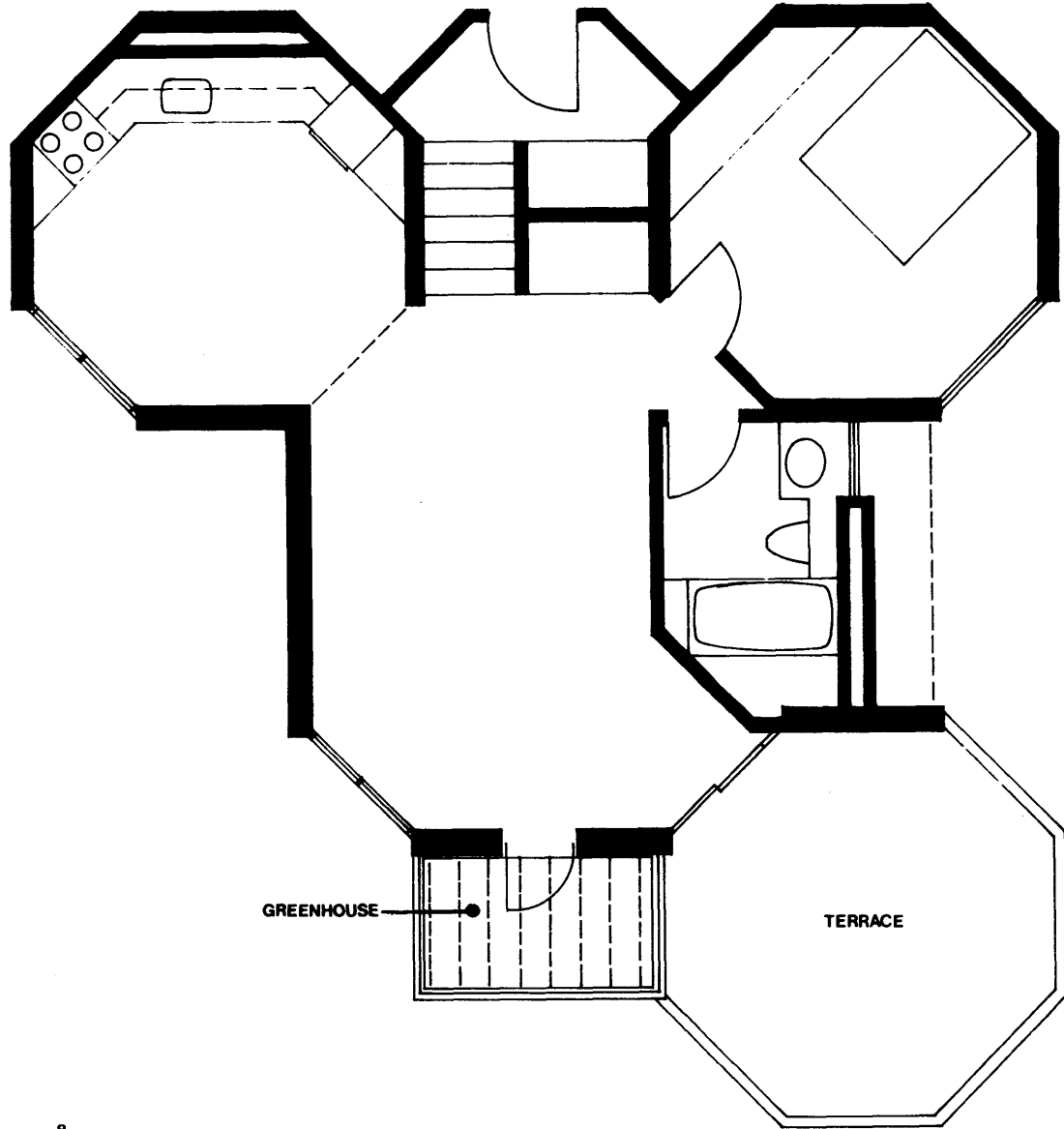

GREENHOUSE

TERRACE

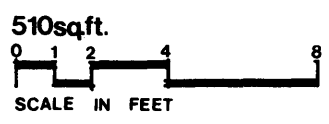

B2 ONE BEDROOM UNIT

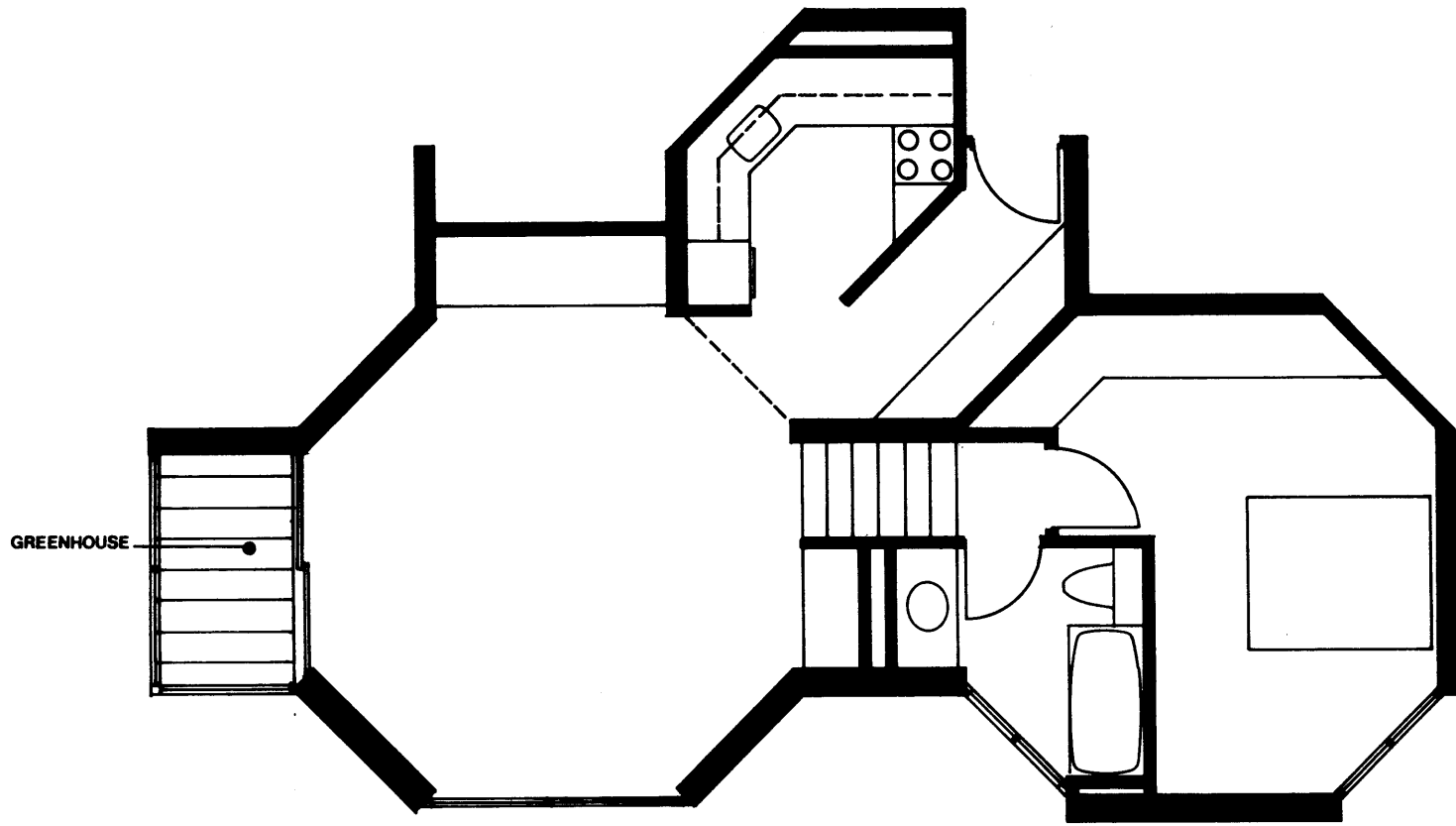

GREENHOUSE

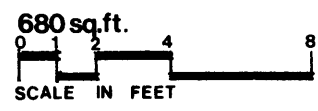

B3 ONE BEDROOM UNIT

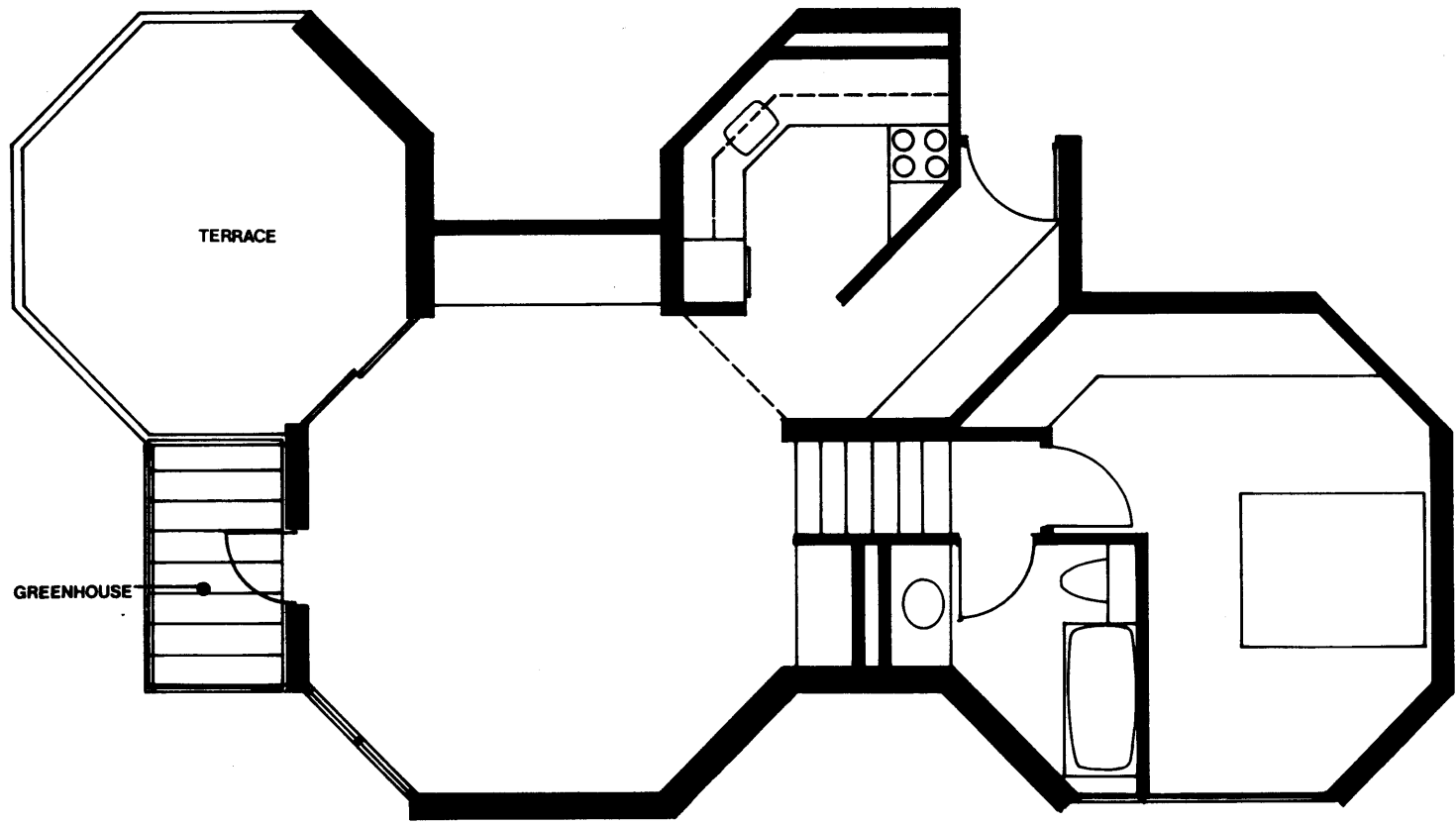

680 sq.ft.  
0 1 2 4 8  
SCALE IN FEET



B4 ONE BEDROOM UNIT

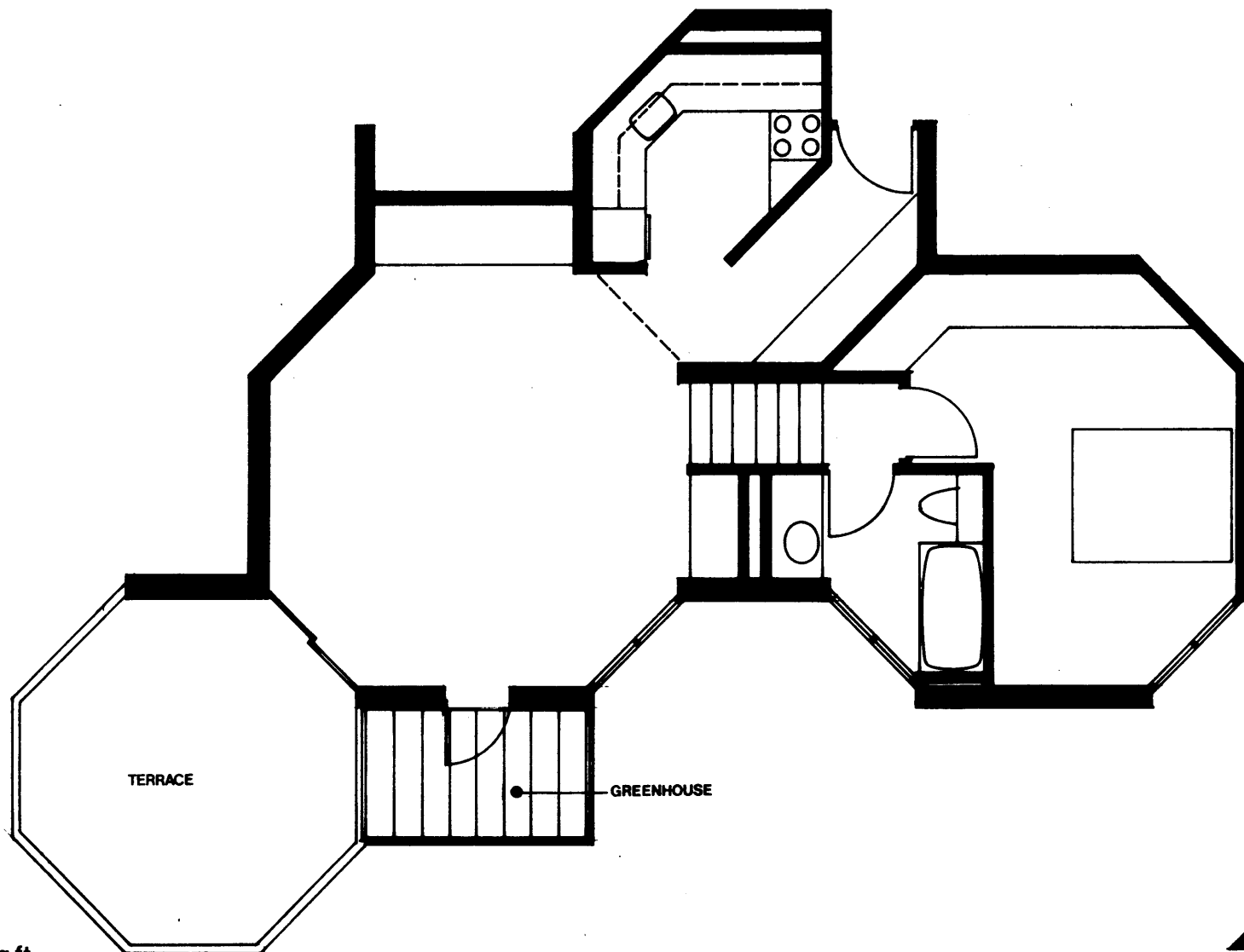

TERRACE

GREENHOUSE

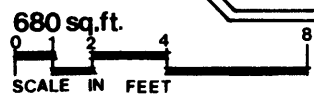

B5 ONE BEDROOM UNIT

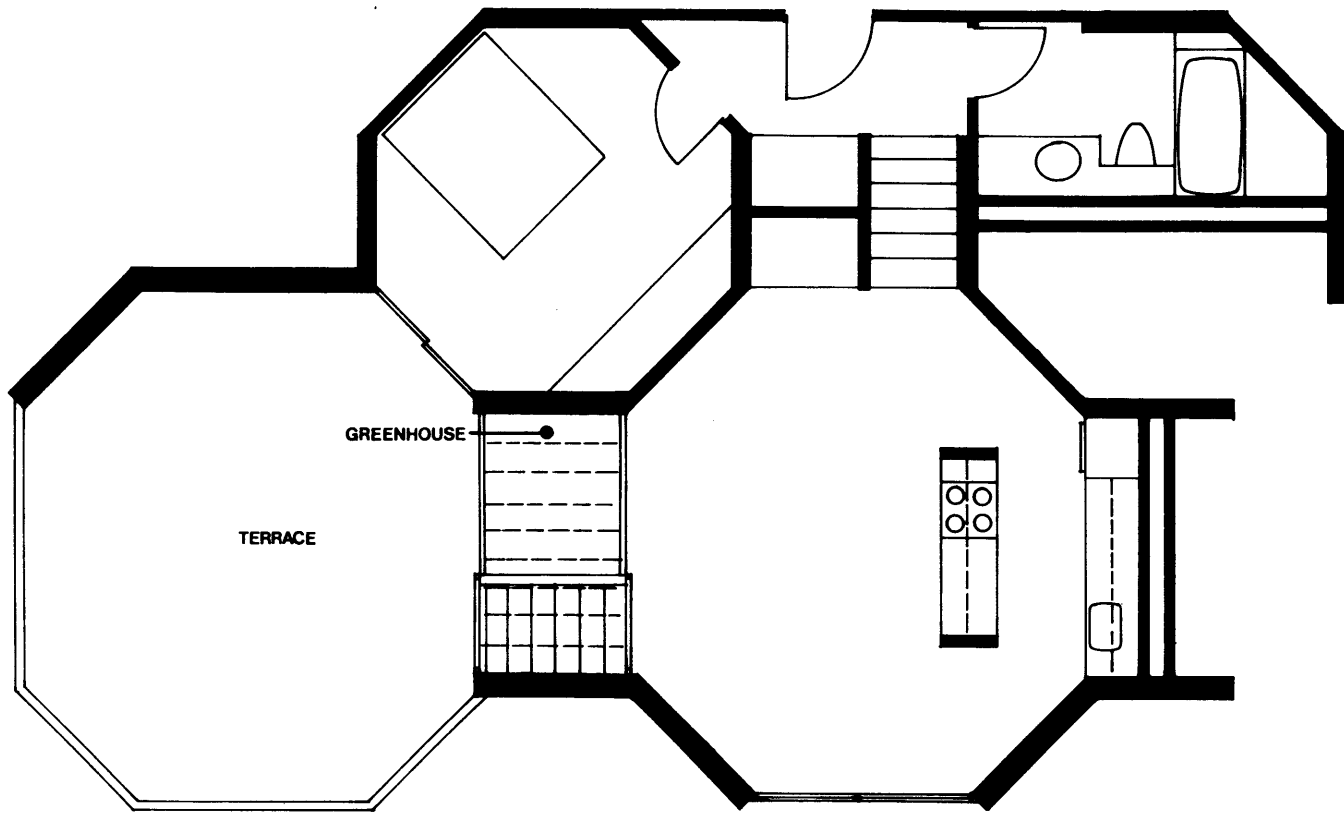

600sq.ft.

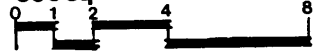

SCALE IN FEET



B6 ONE BEDROOM UNIT

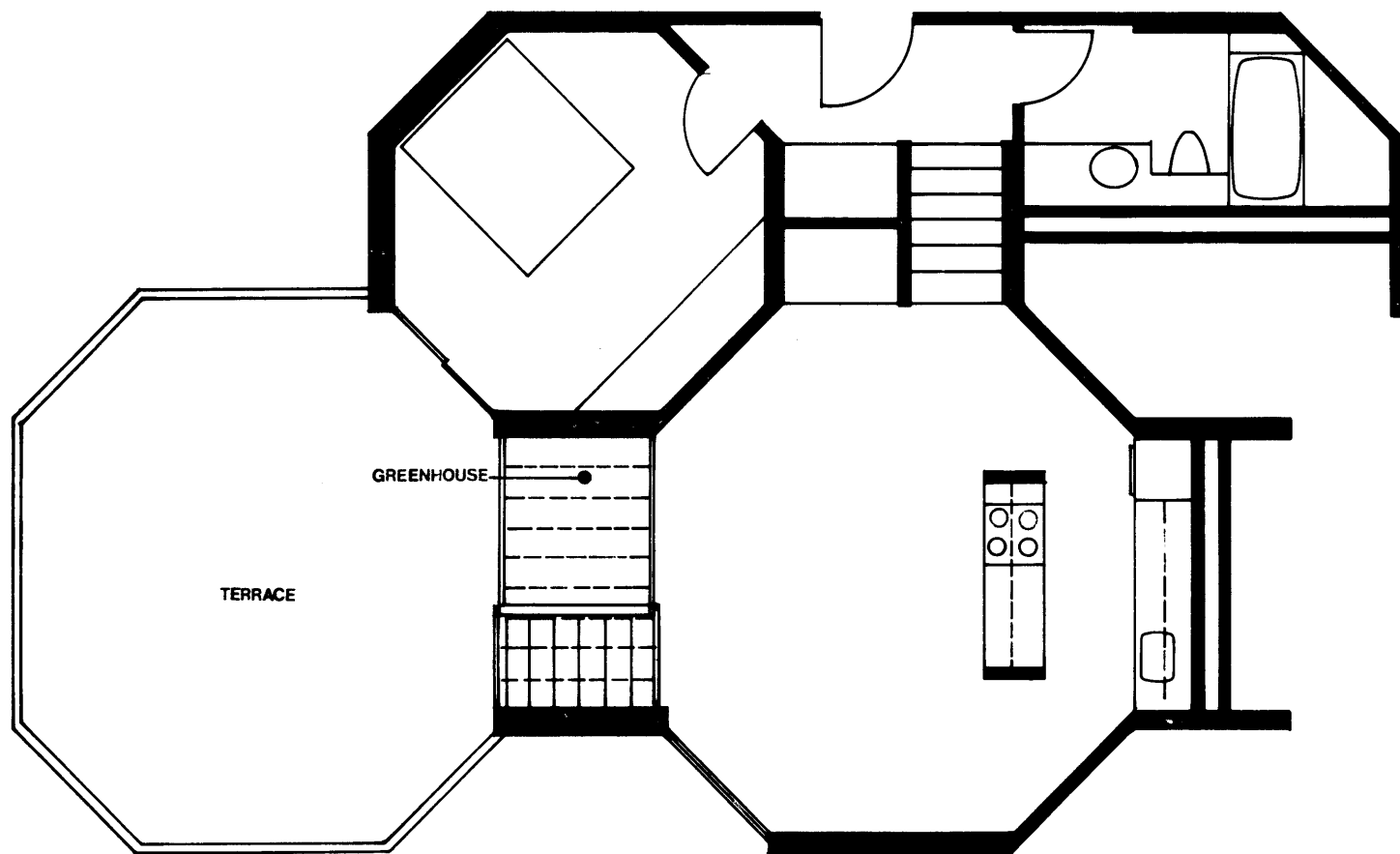

600 sq.ft.  
0 1 2 4 8  
SCALE IN FEET



B7 ONE BEDROOM UNIT



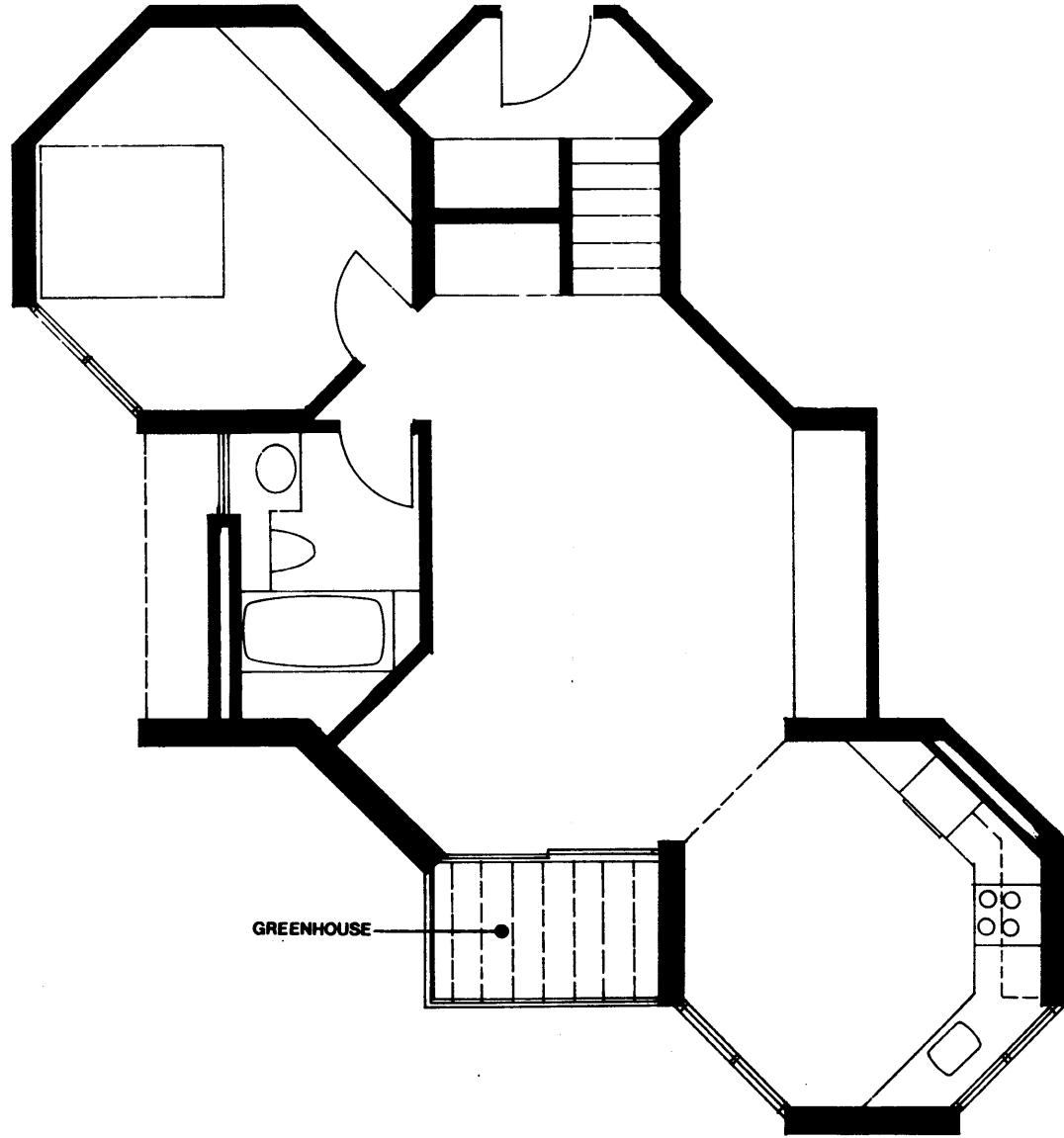

GREENHOUSE

510sq.ft.



SCALE IN FEET



B8 ONE BEDROOM UNIT

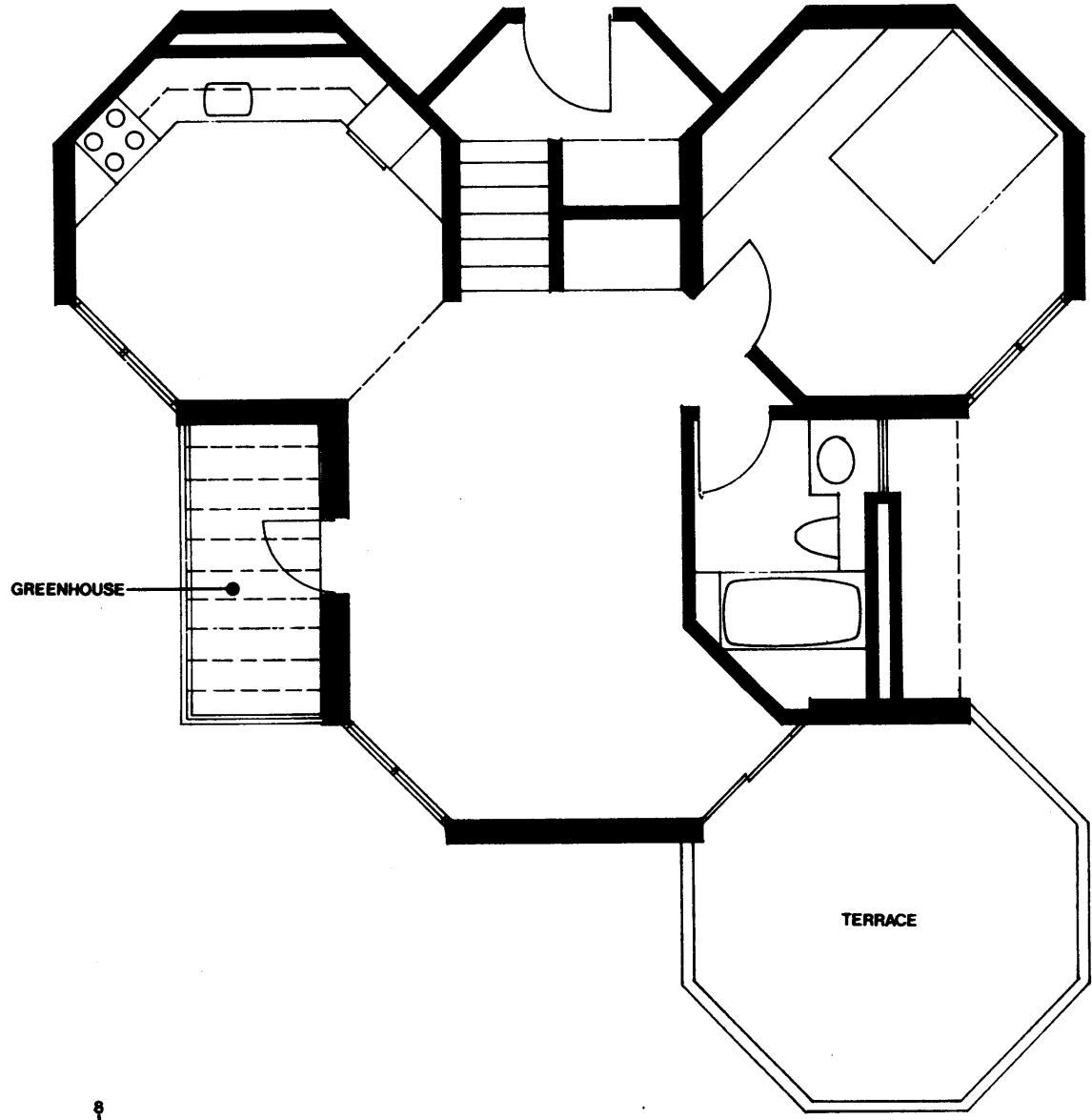

GREENHOUSE

TERRACE

510sq.ft.



SCALE IN FEET



B9 ONE BEDROOM UNIT

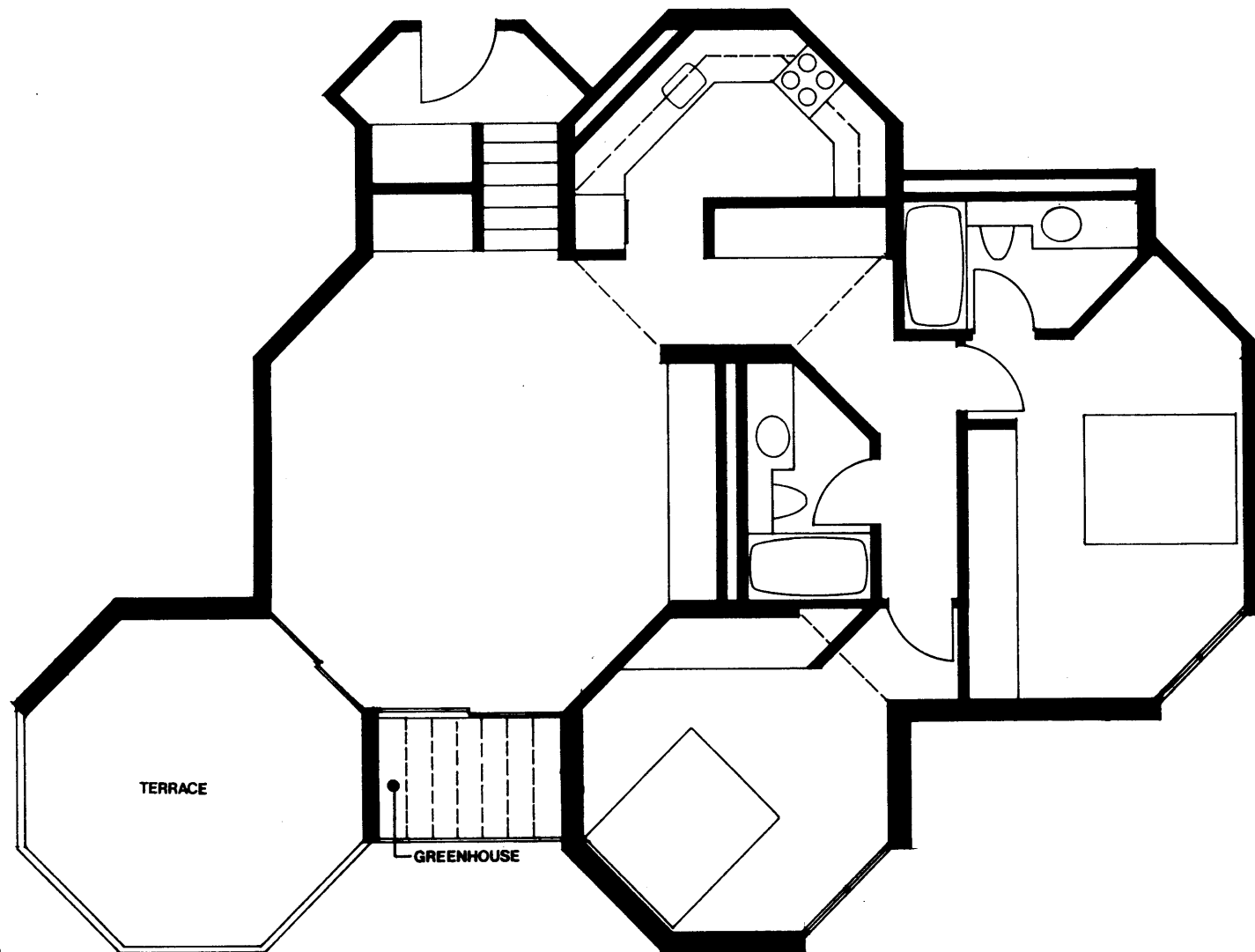

900 sq.ft.



SCALE IN FEET



NORTH

C1 TWO BEDROOM UNIT

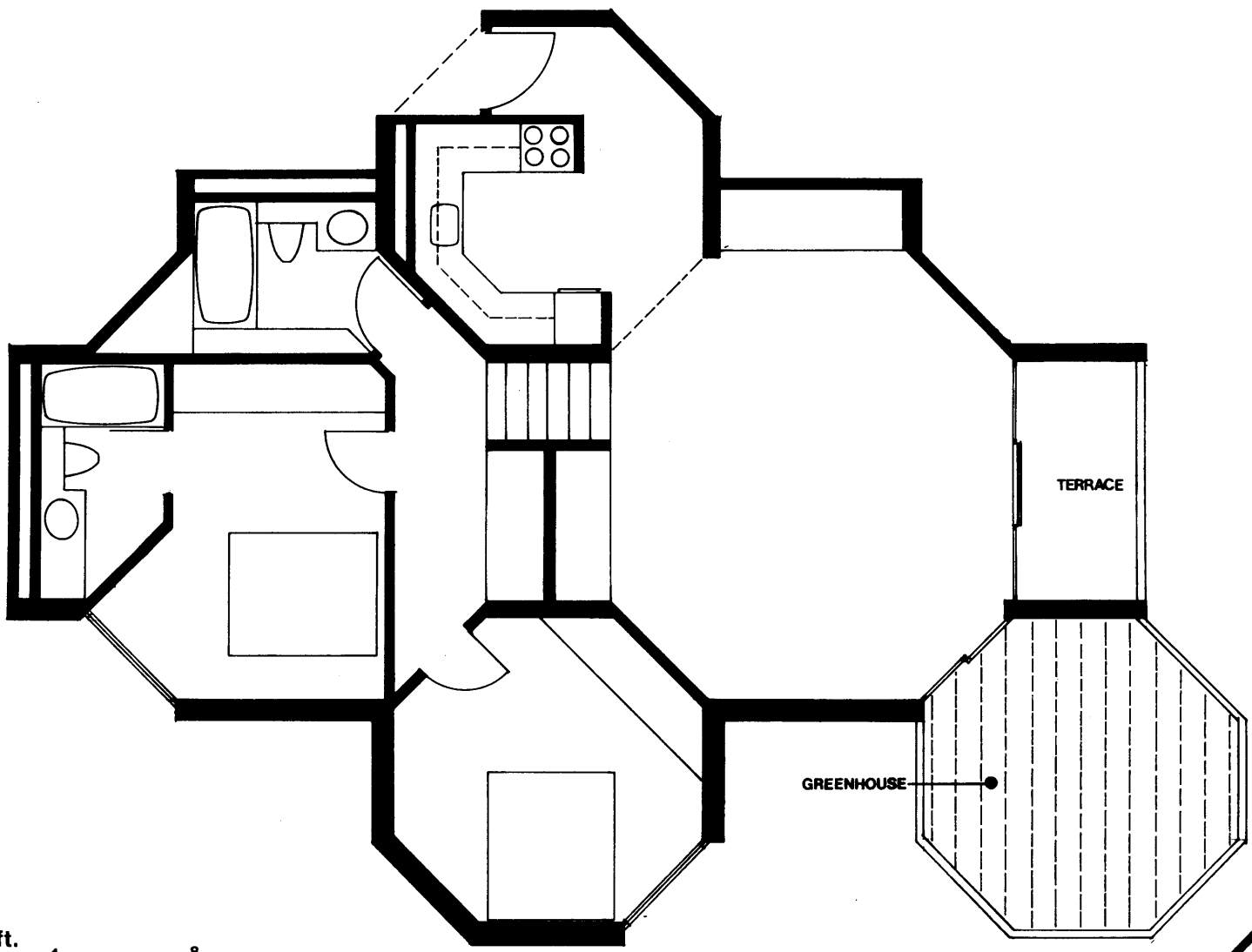

895 sq.ft.  
0 2 4 8  
SCALE IN FEET

GREENHOUSE

TERRACE



C2 TWO BEDROOM UNIT

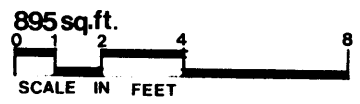
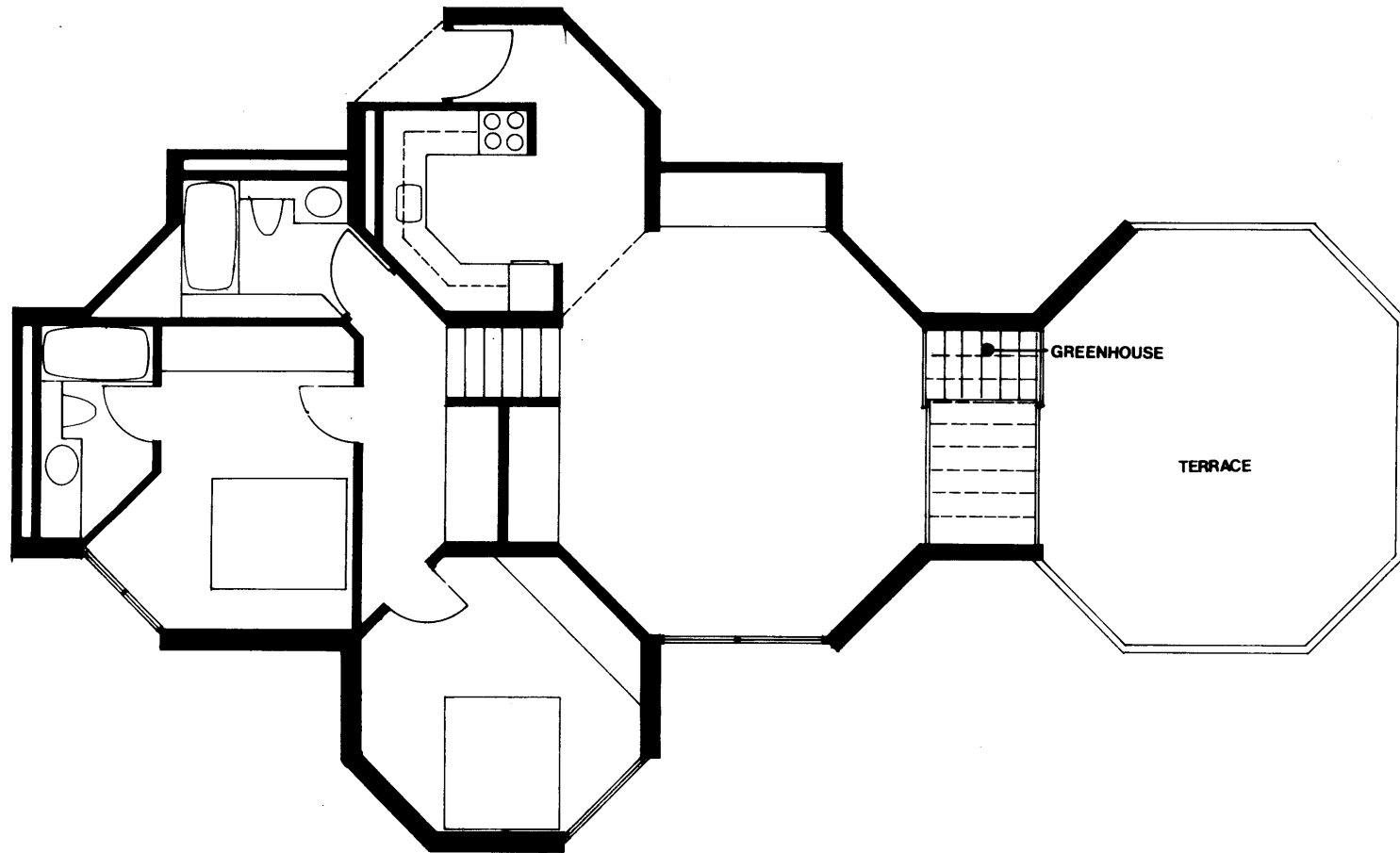

C3 TWO BEDROOM UNIT

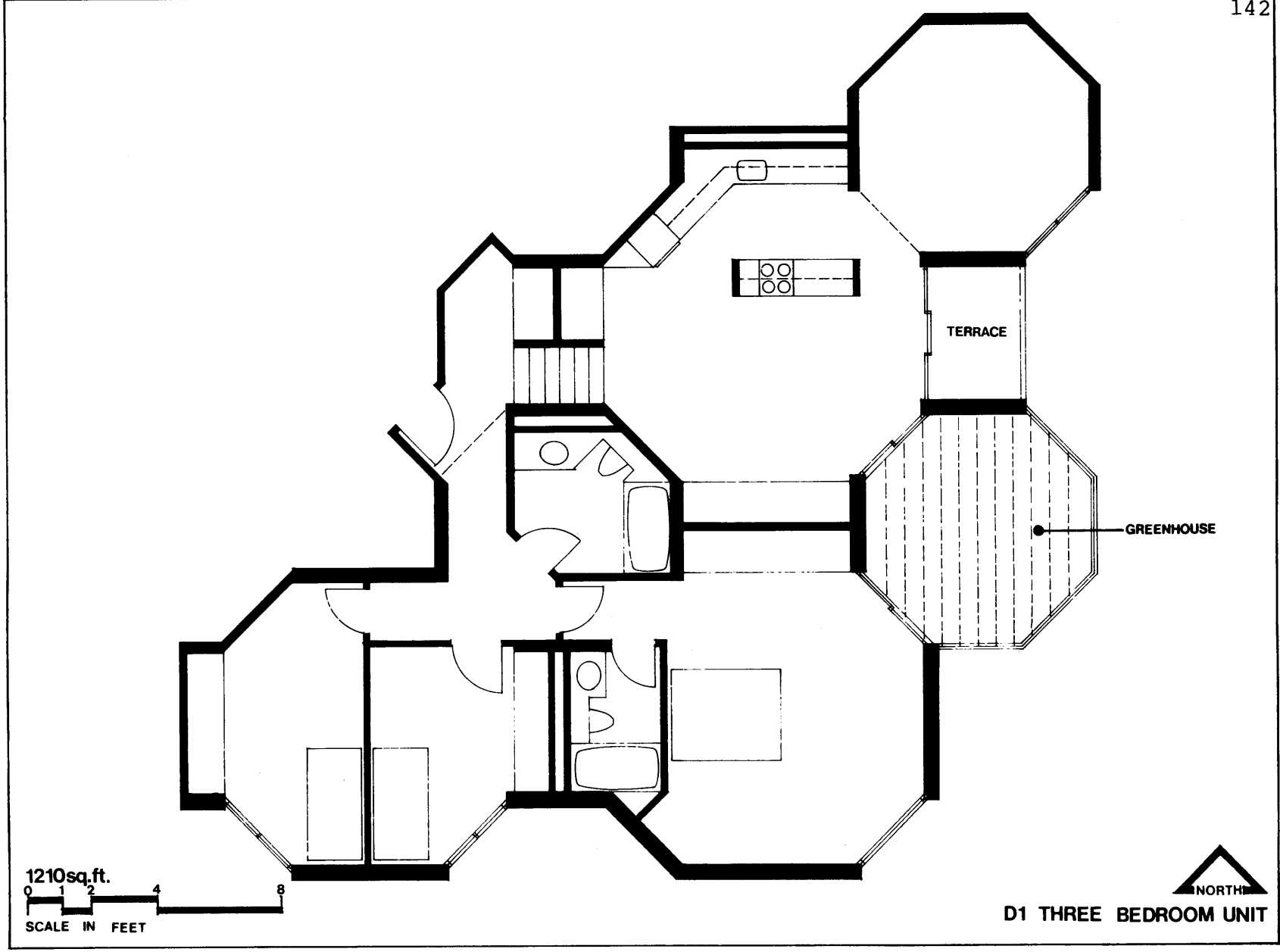

1210sq.ft.  
0 1 2 4 8  
SCALE IN FEET

TERRACE

GREENHOUSE



D1 THREE BEDROOM UNIT

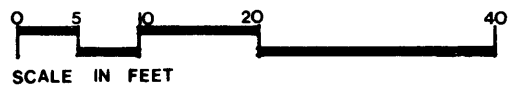
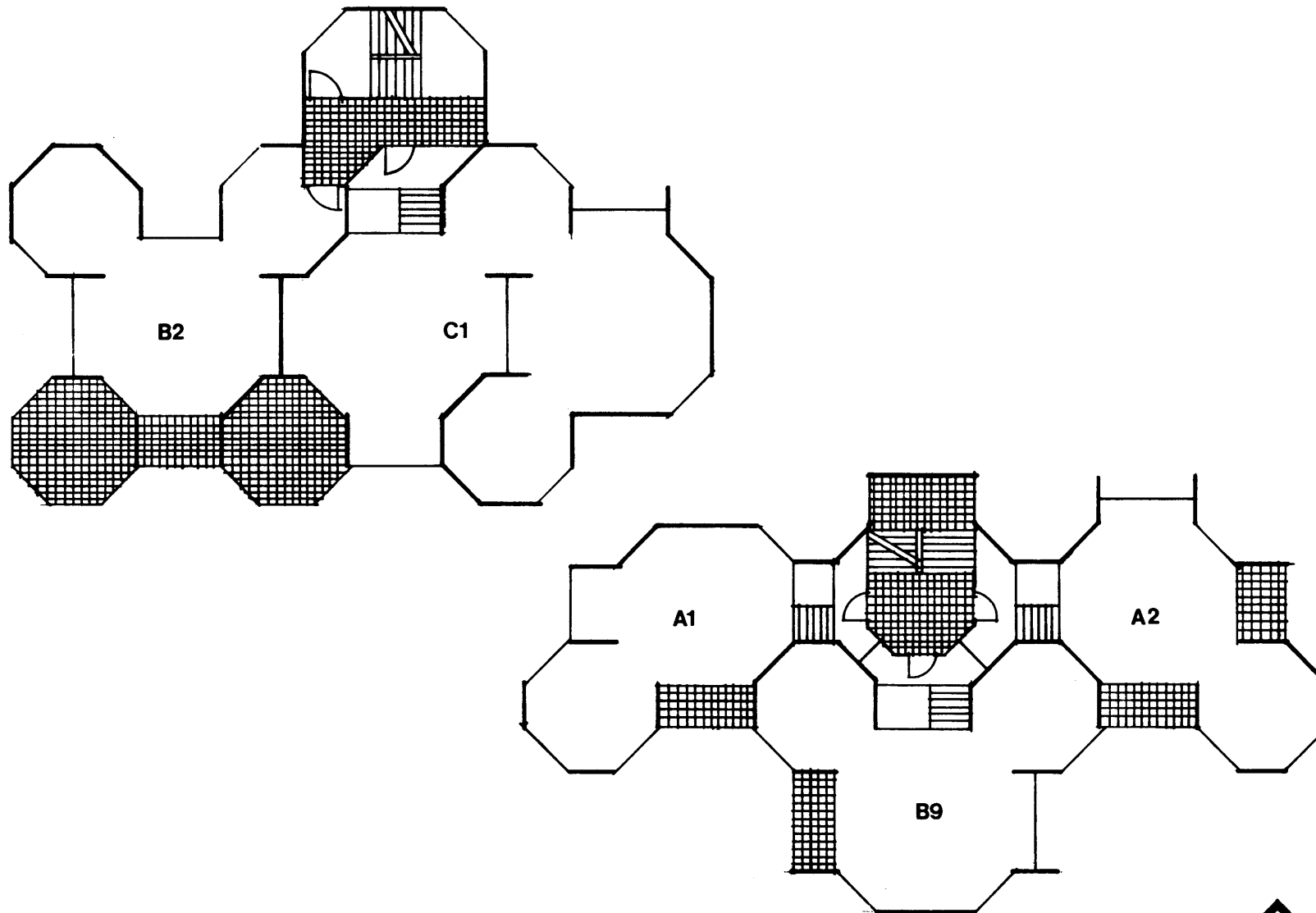

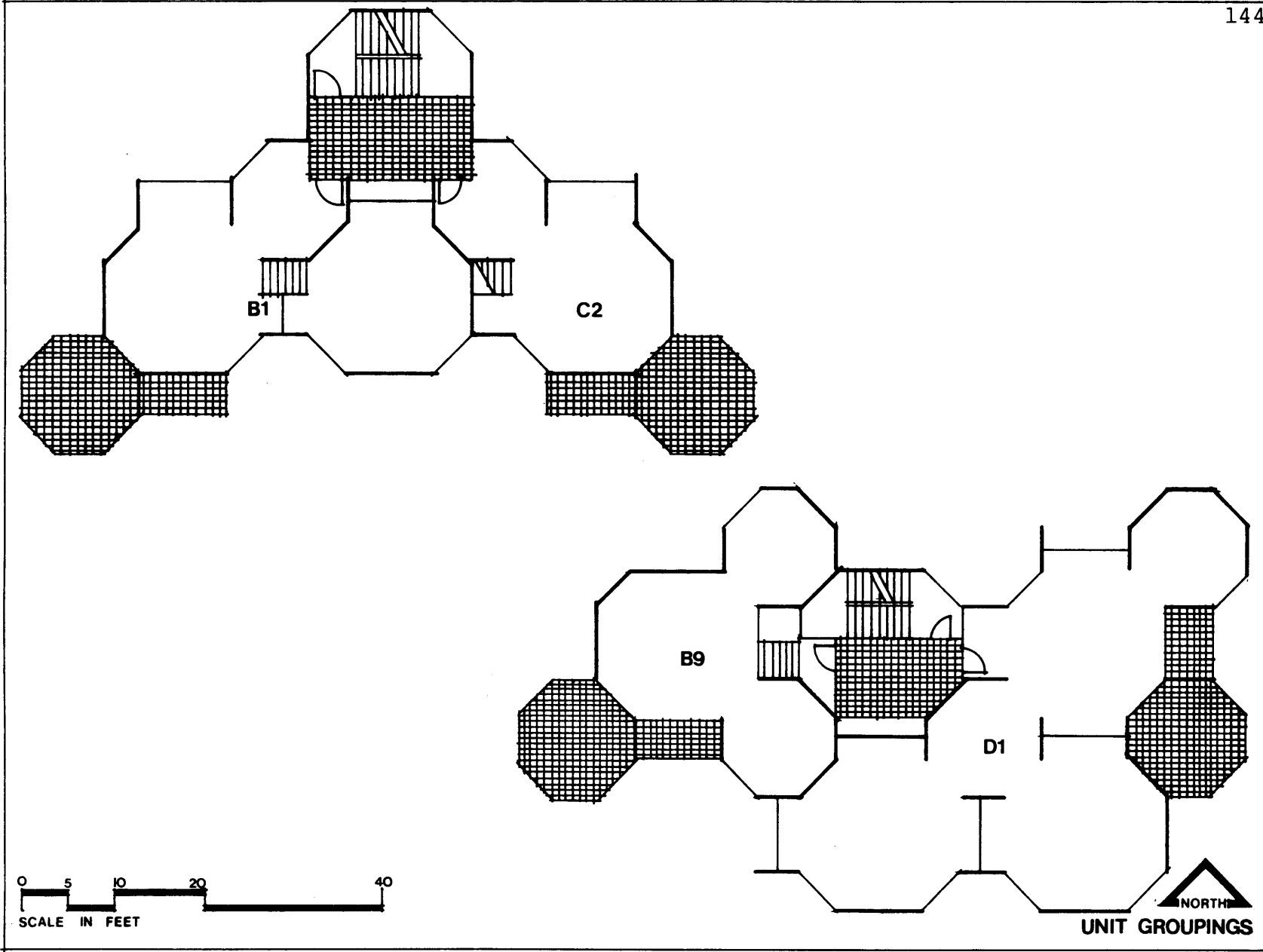



PHYSICAL DESCRIPTION OF UNIT A-1

1) floor area	510 sq.ft.
volume	4080 cu.ft.
exposed surface area: walls	205 sq.ft.
windows	58 sq.ft.

HEAT LOSS OF UNIT A-1

1) heat loss through the building skin:

	<u>area</u>	<u>U value</u>	<u>UA</u>
exterior walls	205 sq.ft.	.058	11.89 btu/hr <sup>o</sup> F
windows	58 sq.ft.	.522	30.276 btu/hr <sup>o</sup> F

infiltration:

$$4080 \text{ cu.ft.} \times 1 \text{ air change/hr.} \times 0.018 = 73.44 \text{ btu/hr}^{\circ}\text{F}$$

total heat loss:

$$42.166 \text{ btu/hr}^{\circ}\text{F} + 73.44 \text{ btu/hr}^{\circ}\text{F} = 116 \text{ btu/hr}^{\circ}\text{F}$$

2) internal gains:

people	153 btu/hr.	(average over 24hr. period)
lights	578 btu/hr.	" "
appliances	766 btu/hr.	" "
total	<u>1497</u> btu/hr.	" "

3) balance point:

(based on Timothy Johnson's computer program)

$$65^{\circ}\text{F thermostat setting} - \frac{\text{internal gains}}{\text{UA}}$$

$$65^{\circ} - \frac{1497 \text{ btu/hr.}}{116 \text{ btu/hr.}}$$

4) the computer program calculates:

balance point	52 <sup>o</sup> F
degree hrs./heating season	80,880
seasonal heat loss	10,310,082 btu

SOLAR HEAT GAIN OF UNIT A-1

146

(solar heat gain data is based on tables published by The Environmental Action)

- 1) solar gain through south windows:  
seasonal heat gain      141,728 btu/sq.ft.  
window area              31 sq.ft.  
total-  
141,728 btu/sq.ft. x 31 sq.ft. = 4,393,568 btu
  
- 2) solar gain through southeast windows:  
seasonal heat gain      115,842 btu/sq.ft.  
window area              27 sq.ft.  
total-  
115,842 btu/sq.ft. x 27 sq.ft. = 3,127,734 btu
  
- 3) total seasonal solar heat gain:  
south windows            3,127,734 btu  
southeast windows       4,393,568 btu  
total                      7,521,302 btu

COMPARISON OF HEAT LOSS TO SOLAR HEAT GAIN

- 1) seasonal heat loss                      10,310,082 btu  
seasonal solar heat gain                  7,521,302 btu
  
- 2) % of heat supplied by sun              71.5%

PHYSICAL DESCRIPTION OF UNIT B-2

1) floor area	625 sq.ft.
volume	5000 cu.ft.
exposed surface area: walls	430 sq.ft.
windows	129 sq.ft.

HEAT LOSS OF UNIT B-2

1) heat loss through the building skin:

	<u>area</u>	<u>U value</u>	<u>UA</u>
exterior walls	430 sq.ft.	.058	24.94 btu/hr <sup>°F</sup>
windows	129 sq.ft.	.522	67.34 btu/hr <sup>°F</sup>

infiltration:

$$5000 \text{ cu.ft.} \times 1\text{-}1/2 \text{ air changes/hr.} \times 0.018 = 135 \text{ btu/hr}^{\circ}\text{F}$$

total heat loss:

$$92.278 \text{ btu/hr}^{\circ}\text{F} + 135 \text{ btu/hr}^{\circ}\text{F} = 227.3 \text{ btu/hr}^{\circ}\text{F}$$

2) internal gains:

people	327 btu/hr. (average over 24hr. period)	
lights	709 btu/hr.	"
appliances	1150 btu/hr.	"
total	<u>2186 btu/hr.</u>	"

3) balance point:

(based on Timothy Johnson's computer program)

$$65^{\circ}\text{F thermostat setting} - \frac{\text{internal gains}}{\text{UA}}$$

$$65^{\circ}\text{F} - \frac{2186 \text{ btu/hr.}}{227.3 \text{ btu/hr.}}$$

4) computer program calculates:

balance point	55.4 <sup>°</sup> F
degree hrs./heating season	105,523
seasonal heat loss	23,985,491 btu

(solar heat gain data is based on tables published by The Environmental Action)

- 1) solar gain through southeast windows:  
seasonal heat gain      115,842 btu/sq.ft.  
window area              54 sq.ft.  
total-  
115,842 btu/sq.ft. x 54 sq.ft. = 6,255,468 btu
  
- 2) solar gain through east windows:  
seasonal heat gain      66,960 btu/sq.ft.  
window area              9 sq.ft.  
total-  
66,960 btu/sq.ft. x 9 sq.ft. = 602,640 btu
  
- 3) solar gain through south windows:  
seasonal heat gain      141,728 btu/sq.ft.  
window area              19.5 sq.ft.  
total-  
141,728 btu/sq.ft. x 19.5 sq.ft. = 2,763,696 btu
  
- 4) solar gain through southwest windows:  
seasonal heat gain      115,842 btu/sq.ft.  
window area              54 sq.ft.  
total-  
115,842 btu/sq.ft. x 54 sq.ft. = 6,255,468 btu
  
- 5) total seasonal solar heat gain:  
southeast windows      6,255,468 btu  
east windows              602,640 btu  
south windows            2,763,696 btu  
southwest windows      6,255,468 btu  
total 15,877,272 btu

## COMPARISON OF HEAT LOSS TO SOLAR HEAT GAIN OF UNIT B-2

1) seasonal heat loss	23,985,491 btu
seasonal solar heat gain	15,877,272 btu
2) % of heat supplied by sun	66.2%

**CONCLUSION  
APPENDIX  
BIBLIOGRAPHY**

## CONCLUSION

There is an ever increasing need for buildings which are not reliant on non-renewable sources of energy. Exploration of building systems which use renewable sources of energy is necessary if an energy crisis is to be avoided in the future. Housing comprises a large portion of the total energy consumption. Building systems for housing that are energy efficient and utilize solar energy would decrease this energy usage.

Industrialization in housing construction would decrease energy required for material production and consumption. By the incorporation of passive solar/energy conservation concepts in industrialized housing systems, total energy savings would result. All systems involv-

ed in the creation and utilization of housing would be integrated into one complete energy efficient system.

Concrete, because of its excellent thermal properties, is a logical choice for an industrialized housing system which is passively solar heated. Though at present the market for precast concrete is not extensively developed, this material will become increasingly important in the future as fuel prices and construction labor costs increase.

Industrialized systems in precast concrete afford many opportunities for adaptation to climate and energy needs in housing. Hopefully, research will continue to explore the integration of industrialized housing with passive solar energy.

## APPENDIX

I. Summary of the Building and Construction Exposition and Conference

The Building and Construction Exposition and Conference was held at McCormick Place in Chicago, Illinois from November 1-3, 1977. This was an international trade fair of building products, systems, equipment, and machinery. I attended the event which involved approximately 15,000 persons of the construction industry: architects, engineers, contractors, builders, developers, building owners/operators, government construction executives, real estate executives, and other groups.

The focus of the conference was "energy". The exhibition which ran concurrent with the conference featured a

special section on energy saving and alternate energy systems. The conference was targeted into four segments involving government and industry leaders on the subject of energy. The four segments were:

- 1) The Government Thrust: President Carter's Energy Program and Government Construction
- 2) Solar Energy - A Building Team Evaluation of Projects in Place
- 3) The Challenge of Design For Energy Efficient Building
- 4) Energy Retrofitting - A Golden Opportunity

The first segment was directed by a panel chaired by John Morris Dixon, F.A.I. A., Editor of Progressive Architecture, and the three speakers were: James B. Shea, jr., Commissioner of the Public



Building Service, U.S. General Services Administration; Paul A. London, Deputy Assistant Administrator for Conservation Policy, Coordination Federal Energy Administration; and John Eberhard, A.I.A. Research Corporation, Energy Building Technology and Standards Research with H.U.D. The discussion centered on the great influence of the administration's energy policy on construction in general and building construction in particular.

The second segment of the conference was directed by Oliver Witte, Editor of Building Design and Construction, and the speaker were: Lawrence G. Spielvogel, P.E. of Lawrence G. Spielvogel, Inc.; Gary J. Young of Friendship Federal Savings and Loan Association; P. Richard Rittleman, A.I.A., of Burt, Hill and Associates; and

David P. Hull of Al Cohen Construction Co. This session was a discussion on the practical consideration of applying current solar technologies. The focus was on performance and the experience of the conference members with past solar projects.

The third session was moderated by Walter F. Wagner, Editor of Architecture Record and the speakers were: John D. Anderson, A.I.A. of John D. Anderson and Associates; Jack Beech of Joseph R. Loring and Associates, Inc.; and John Honeycomb of the IBM Corporation. This panel discussed the incentives for the design energy efficient buildings and the cost-effective tools. Alternatives and priorities for design professionals was of importance.

The last session was moderated by

John M. McGinty, A.I.A., president of the A.I.A. The speakers were: Jack E. Tumility, P.E. of Jack E. Tumility, P.E. and Associates; Joseph Newman of Tishman Research Corporation; and Robert G. Burkhardt of Robert G. Burkhardt and Associates. This session dealt with retrofitting of existing buildings for energy efficiency. The energy retrofitting standards projections, and the economic advantages and procedures for retrofitting were important topics.

At the same time that the sessions were occurring at the Building and Construction Exposition and Conference, a large exhibit of solar products and alternative energy systems was being displayed. This afforded the opportunity to inspect the latest developments in the

field of solar products.

## BIBLIOGRAPHY

- A.I.A. Research Corporation, NEW DESIGN CONCEPTS FOR ENERGY CONSERVING BUILDINGS. Washington, D.C., 1977.
- A.I.A. Research Corporation, ENERGY CONSERVATION IN BUILDING DESIGN. Washington, D.C. 1974.
- Arizona State University, EARTH INTEGRATED ARCHITECTURE. Tempe, Arizona, 1975.
- Arizona State University, SOLAR ORIENTED ARCHITECTURE. A.I.A. Research Corp., Washington, D.C., 1975.
- Blewett, Clarence, ARCHITECTURAL CONCRETE NORMS. M.I.T. Thesis, Cambridge, 1977.
- Cary Arboretum, BUILDINGS AND THE ENVIRONMENT. New York, 1976.
- Davis and Shubert, ENERGY IN BUILDING DESIGN.
- Deeson, A.F.L., THE COMPREHENSIVE INDUSTRIALIZED BUILDING ANNUAL 1966,1977. House Publications Limited, London, 1965.
- Diamant, R.M.E., INDUSTRIALIZED BUILDING 2. Liffé Books Ltd., London, 1965.
- Dietz, Albert and Cutler, Lawrence, INDUSTRIALIZED BUILDING SYSTEMS FOR HOUSING. M.I.T. Press, Cambridge, 1971.
- Dubin-Mindel-Bloome Associates, ENERGY CONSERVATION DESIGN GUIDELINES.
- ERDA, A NATIONAL PLAN FOR ENERGY RESEARCH, DEVELOPMENT AND DEMONSTRATION. U.S. Government, Washington, D.C., 1977.
- Gary, Robert, SURVEY OF SOLAR BUILDINGS. University of Oregon, Eugene, Oregon, 1975.
- Giffels Associates, SOLAR ENERGY AND HOUSING. A.I.A. Research Corporation, Washington, D.C., 1975.

- Griffen, C.W., ENERGY CONSERVATION IN BUILDINGS. Construction Specifications Institute, Washington, D.C., 1974.
- HUD, SOLAR HEATING AND COOLING DEMONSTRATION PROGRAM. U.S. Government, Washington, D.C. 1976.
- Jennings, Burgess H., ENVIRONMENTAL ENGINEERING. International Textbook Company, Scranton, New York, 1970.
- Joint Venture and Friends, HERE COMES THE SUN 1981. A.I.A. Research Corporation, Washington, D.C., 1975.
- Koncz, Dr. Ing. Tihamer, MANUAL OF PRECAST CONCRETE CONSTRUCTION, VOL.III: SYSTEM BUILDING WITH LARGE PANELS. Weisbaden und Berlin, 1970.
- Lewicki, Bohdan, BUILDING WITH LARGE PREFABRICATES. Elsevier Publishing Co., London, 1966.
- McGuinness, William J., MECHANICAL AND ELECTRICAL EQUIPMENT FOR BUILDINGS. John Wiley and Sons, New York, 1971.
- Olgay, Victor, DESIGN WITH CLIMATE. Princeton University Press, Princeton, New Jersey.
- Prestressed Concrete Institute, PCI JOURNAL. Jan./Feb., vol. 23, #1, 1978.
- Riordan, Michael and Anderson, Bruce, THE SOLAR HOME BOOK. Cheshire Press, Harrisville, New Hampshire, 1976.
- Systems and Industrialization Program 1976, HOUSING VARIATIONS. M.I.T., 1976.
- Szokolay, S.V., SOLAR ENERGY AND BUILDING. Architectural Press, London, 1975.
- Total Environmental Action, SOLAR ENERGY HOME DESIGN IN FOUR CLIMATES. A.I.A. Research Corporation, Washington, D.C., 1975.