

"MULTI-USE" AIRPORT DESIGN:
A NEW TERMINAL FOR MALPENSA INTERNATIONAL AIRPORT,
MILAN, ITALY

by

Constantine Seremetis

B.S. Civil and Urban Engineering, University of Pennsylvania
(1981)

S.M. Civil Engineering, Massachusetts Institute of Technology
(1984)

Submitted to the Department of
Architecture
in partial fulfillment of the requirements
for the Degree of

MASTER OF ARCHITECTURE

at the

MASSACHUSETTS INSTITUTE OF TECHNOLOGY
June, 1986

© Constantine Seremetis, 1986.

The Author hereby grants to M.I.T.
permission to reproduce and to publicly distribute copies
of this thesis document in whole or in part.

Signature of Author

Constantine Seremetis
Department of Architecture
May 9, 1986

Certified by

Dennis Frenchman, Thesis supervisor
Lecturer, Department of Architecture

Accepted by

Thomas Chastain, Chairman
Departmental Committee on Graduate Students

Rotch

MASSACHUSETTS INSTITUTE
OF TECHNOLOGY

JUN 06 1986

LIBRARIES

**"MULTI-USE" AIRPORT DESIGN: A NEW TERMINAL FOR
MALPENSA INTERNATIONAL AIRPORT, MILAN, ITALY**

by

Constantine Seremetis

Submitted to the Department of
Architecture on May 9, 1986
in partial fulfillment of the requirements
for the Degree of

MASTER OF ARCHITECTURE

at the

MASSACHUSETTS INSTITUTE OF TECHNOLOGY

ABSTRACT

The design of an airport terminal building can be viewed as a specialized case of the design of a large building. One of the major planning and design issues of typical large buildings is that of accomodating multiple uses. Airport terminals are not mixed-use in the sense that commercial and residential space share the same building, but they are from the point of view that they enclose some very specialized functions together with commercial, hotel, office, and meeting space. The trend has been to increase these functions at airports since they are highly concentrated nodes of long range transportation. The particular uses depend largely on the city which the airport serves.

The airport's location and proximity to a city should also influence its architecture. The image, materials, and theme of any building are important, but especially so for a terminal which is to welcome people from distant locations.

These considerations were applied to a specific case: the design of a new terminal building for Malpensa International Airport in Milan, Italy. The main effort here was to develop a major terminal facility based on a local theme, the arcade.

Thesis Supervisor: Dennis Frenchman
Title: Lecturer in the Department of Architecture

ACKNOWLEDGEMENTS

I would first like to thank professor Amadeo Odoni for providing me with all the necessary information about the proposed plans for Malpensa.

To professor Richard DeNeufville, I must also say thanks, for his time and comments, but especially for his continued support and encouragement.

I would especially like to thank Dennis Frenchman, for his advice as my supervisor, his time during an extremely busy semester, and for all I've learned from him.

My parents Michael and Anastasia Seremetis, also deserve a word of thanks for the financial support that has gotten me through my education.

Finally, I thank my wife, Elaine, for all her help, patience, and understanding. Her constant encouragement has really made the difference in this difficult semester.

TABLE OF CONTENTS

Introduction	9
General Discussion	13
MALPENSA	
Airports at Milan: Malpensa and Linate	37
Airport Theme	40
Description of new Terminal	44
Drawings	49
Photographs of model	64
Passenger Sequence of Events	70
Appendices	
Appendix A: Summary of Program Development	82
Appendix B: Airport Terminal Types	91
Appendix C: Bibliography	101

INTRODUCTION

INTRODUCTION

The concept of a multi-use airport is not an entirely new one, but one that has been slowly evolving. More and more airports are now including functions which some time ago were considered non-essential or simply not economical. As the number of passengers has increased so has the demand for more services and amenities. Paralleling that trend is, of course, the collective spending power of these travelers. This has, in turn, made a number of businesses so profitable that they constitute a substantial portion of the airport's revenues.

In addition to this 'natural' increase in functions there has been an effort by airports to attract more people by broadening their facilities. These range from meeting rooms, conference and trade centers, to museums and other special exhibits and events. One of differences between these functions and the previous ones, is that these tend to make the airport itself the destination.

The most common, and certainly the most natural functions, are hotels, restaurants, and other travel related services. The emphasis in hotel accommodations seems to be to business travelers, since many of them fly often and since they can usually afford the prices. Also, with the availability of meeting rooms on location, business transactions are more convenient.

The result is that airports are very intense nodes of public transportation, with the possibility of becoming even more so. The opportunity to develop airports into centers of activity for the local area are very interesting. This is especially true for airports handling many long distance flights, where people from all the world come together in one spot. Such examples exist where the emphasis in the auxiliary functions is on tourism.

The focus of this thesis is to design an airport terminal, taking into consideration these developments. The decision was to select Malpensa International Airport, for a number of reasons including the availability of information on the current expansion there. This has allowed this project to be based on reality, with a program developed to satisfy the projected passenger traffic for the year 2000. This program was then expanded in order to see what effects the inclusion of multiple uses has on the design of the terminal. Malpensa is an excellent choice as it is a major airport serving mostly international traffic, and is located about one hour out of Milan. The local as well as regional needs are such that they support a multi-use airport.

The added functions include a 300 room hotel, a major shopping facility, meeting and conference rooms, and exhibit spaces, both trade and cultural. The design effort concentrated on the integration of these functions into a terminal, with the additional feature of an Italian theme in the form of an arcade. The precedent for the theme is the Galeria Vittorio Emanuele II, in the center of Milan.

GENERAL DISCUSSION

GENERAL DISCUSSION

Primary and secondary functions.

In their most basic form airports are the links between ground transportation and air transport. The terminal building is the actual place where this transition occurs. As far as the passenger is concerned an airport must accommodate the following activities:

Departing passenger

- Entrance or arrival to the terminal building.
- Check-in (when needed).
- Customs/passport control for international flights.
- Passing security.
- Proceeding to gate.
- Seat assignment (if not already assigned).
- Waiting for boarding.
- Boarding the plane.

Arriving passenger.

- Deplaning.
- Proceeding to the baggage claim area (if needed).
- Customs/passport control for international flights.
- Proceeding to ground transportation.

Transit or transfer passenger.

- Deplaning or arriving from another terminal.
- Customs/passport control (if necessary).
- Proceeding to the next seat assignment or check-in or to another terminal.
- Passing security.
- Waiting for boarding.
- Boarding.

These activities and the requirements they place on space, personnel, and equipment are what I call the primary functions of a terminal. All commercial airports go beyond these most basic needs and provide what I call secondary functions. These typically include restaurants, bars, and a variety of shops as well as sleeping accommodations. The trend is toward an increasing number and diversity of secondary functions.

The consideration of secondary functions is

related to the intentions of the airport authority, the local, state, and federal governments, and many other groups and individuals as well as to the level of service to be provided. Some of these secondary uses are provided because they are deemed necessary or desirable for the comfort and convenience of the passengers. However, many are a direct response to a demand for a service. This economic driving force is very strong and strengthening as it has become evident that the passengers on average are willing to spend quite a bit of money.

In 1984, for example, 67 percent of the revenue of the San Francisco International Airport came from non-airline sources, with departing international passengers spending an average of \$10-11 each. The British Airports Authority has derived nearly half of its total revenue of £ 361 million from non-aeronautical sources in the first quarter of of 1985, including £ 119 million or 33 percent from concessions alone.

Amsterdam's Schiphol Airport, which has become famous for its shopping facilities, generated 34 percent of its total revenue or about FI115 million from commercial activities.(Interavia,9/1985)

With the increasing centralization of airline operations into regional 'hubs' in order for private airlines to maintain or gain on their competition, it has become more important and probably more profitable to develop airports into commercial centers. The problem is that the airports are also much more susceptible to financial problems if a major airline has difficulties or decides to move its 'hub' to another location. There is somewhat of a catch 22, in that an airport authority may not want to make a large investment in commercial development if no major airline is committed to establishing a hub there, while the airline may not want risk its money in an airport that does not provide these amenities. It seems that the more certain approach is

FIGURE 1
Average time spent
on activities at
Logan Airport
source: Brillembourg

FIGURE 2
Passenger activity
preference at
Logan Airport
source: Brillembourg

TIME
(in minutes)

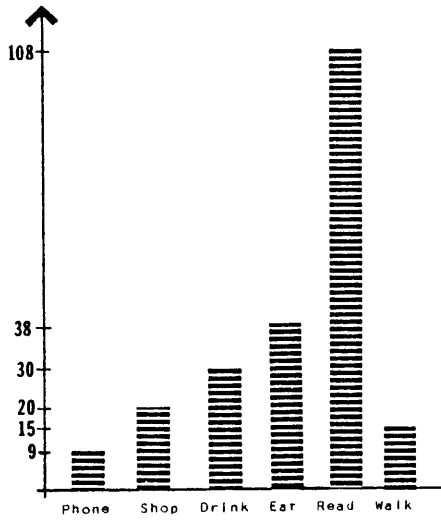

1

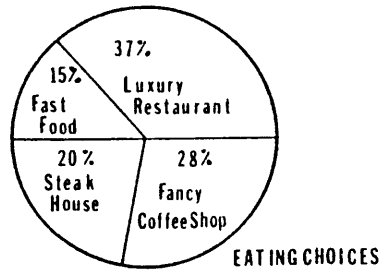

EATING CHOICES

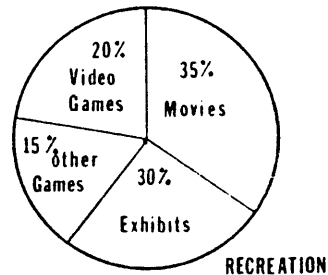

RECREATION

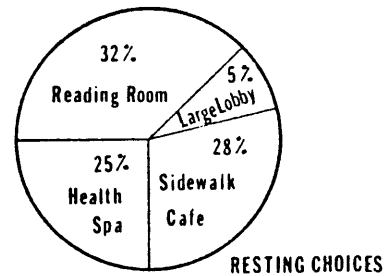

RESTING CHOICES

2

when the commercial development of an airport does rely entirely on the air traffic it can attract, but does depend more on the regional market. Most often this market still comes from air related activities, but there is no reason that the facility cannot accommodate other people. In many existing airports it is extremely difficult to integrate such facilities without severely compromising certain functional aspects.

FIGURE 3
Adjacency matrix
source: Blankenship

The physical relationship between primary and secondary functions varies greatly. Sometimes it is a question of convenience other times it is a requirement (see adjacency matrix.) This relationship is particularly important in terminals that offer a number of secondary uses. Museums and other exhibits at terminals would not be visited if their location was not clear and convenient to most passengers. The economic success of commercial activities is also very sensitive to their location relative to the number of passers by. By placing passenger movement adjacent to these commercial areas in a way that does not restrict the flow, both parties benefit. Passengers may otherwise not be aware of certain facilities, thus not take advantage of them, and those businesses would probably suffer. Additionally, at a terminal such as the one proposed, whose shopping and dining areas are open to the general public, a fairly close relationship between the primary airport functions and the secondary ones makes it a more interesting and exciting experience to the non-passenger.

Examples of typical secondary uses.

Many airports now have major hotels, shopping areas, meeting and conference rooms, as well as some exhibit spaces as integral parts of the terminal building. For example, Tampa International Airport has a hotel which is connected to the main terminal by an

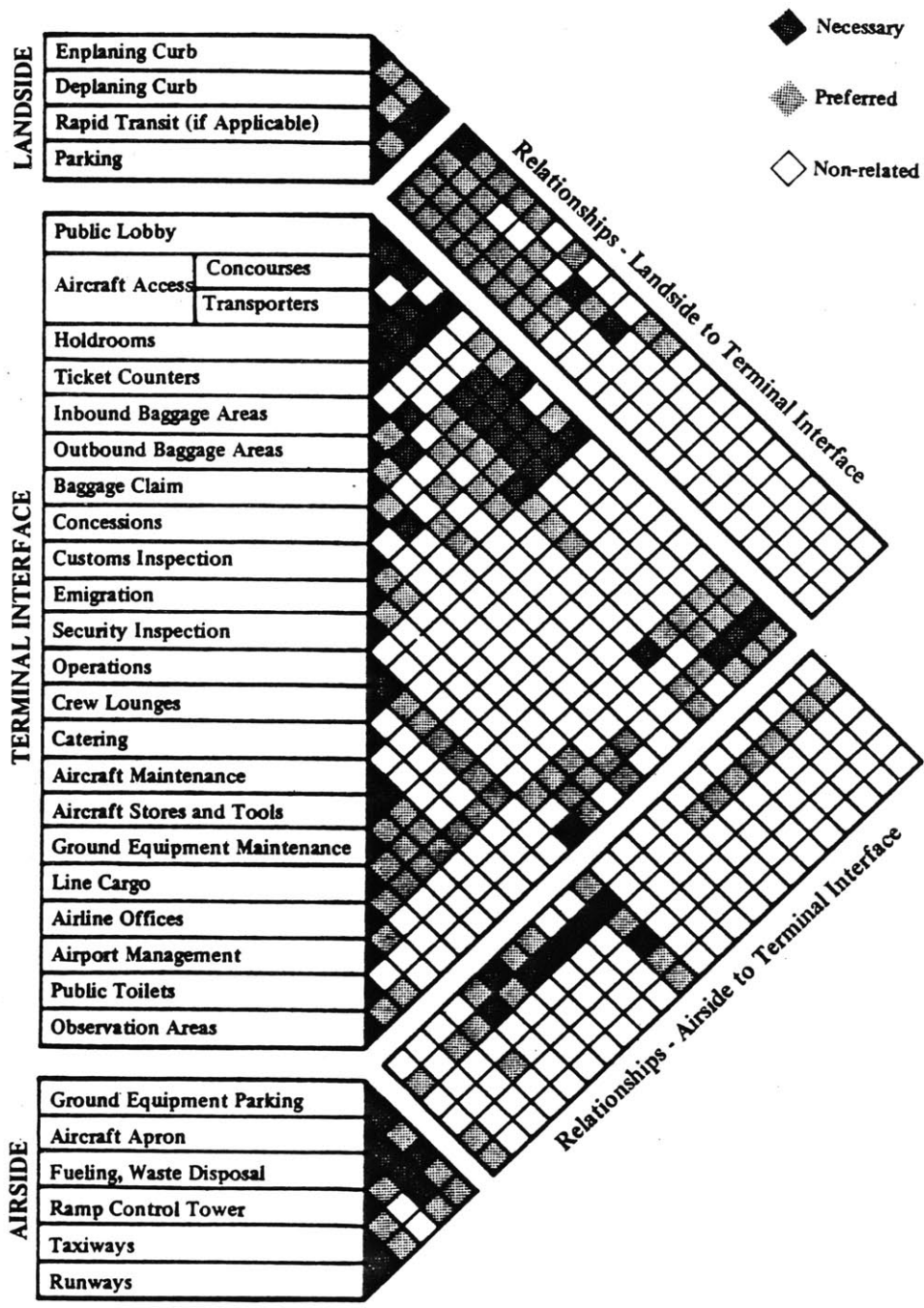

arcade. At the Frankfurt/Main airport construction is currently proceeding on additional hotel capacity, and a major exhibition and conference complex, all directly across the street from the terminal and probably linked underground. At Schiphol Airport, in Amsterdam the airport itself has been developed into a tourist attraction. It now boasts one of the largest duty-free shopping areas in Europe, and has two very large observation decks (one over 800 feet long), which attract over 1.5 million visitors annually.

Aeronautical museums and exhibit spaces of all kinds are also becoming popular at airports. At the New Delhi Airport, for example, there is a 13,000 square foot space conceived as a welcoming point symbolizing peace and friendship. Its main use is to greet and welcome heads of state, government ministers and their entourages. The space is virtually a museum of Indian crafts, with displays of wood carvings, wood, marble, and metal latticework, and hand-painted silk wall hangings. A final example is Dulles International Airport, which will be the location of a major expansion of the National Air and Space Museum with hangers accessible from the taxiways and exhibits open to the public.

Theme and image of airport terminals

All architecture has an image whether or not it is a coherent one, and whether or not it is an intended one. Since a particular image can be planned for and designed, the question really revolves around its selection. The topic of the theme can be independent of its image. It is very important that the theme be compatible with the operations of the terminal, while the image can be freer to make almost any expression.

Airports are particularly well suited to strong images since they represent the unique transition into the

fastest and most technologically advanced mode of public transportation. They are also where people return to land and most often than not are in a place far away from where they left. This makes the terminal a place in which to welcome passengers, not just to prepare them for departure. The image of the airport can make it a much more pleasant and comfortable experience for everyone.

The definition of the proper image has many interpretations, as evidenced by the variety of solutions. One approach is to stress the aspects of flight, as Eero Saarinen did at the TWA Terminal of JFK Airport in New York, and at Dulles in Washington. A different one is the high-tech image like many airports, but the Charles de Gaulle Airport in Paris is a clear example. A third approach is one closer to the images of architecture of the region. These are rarer for larger airports, but good examples are the new Jakarta Airport in Indonesia and the Haj Terminal of the King Abdul Aziz Airport in Jeddah, Saudi Arabia.

The most successful airports tend to be those that work well and have a strong image. This type of success is not measured by economic criteria, but rather by the way the passengers feel about using the terminal.

AIRPORT EXAMPLES

The following is a presentation of five airports which demonstrate some of the considerations discussed. The first four were selected to each represent a different type of terminal, as outlined in Appendix B, the last one is shown because of its unique purpose. All of these examples exhibit a theme or strong image, in addition to multiple functions (to various degrees.)

SCHIPHOL AIRPORT, Amsterdam, Holland

Terminal type: pier
Annual capacity: 18 million passengers

Key Features

- (1) Terminal building,
with 4 piers currently
- (2) Hotel
- (3) Nine storey office building
(for airport related industry)
- (4) Railway station
- (5) Visitors parking area
- (6) Visitors observation decks
National Aeronautical Museum

Amsterdam's Schiphol Airport was opened to civil aviation in 1920. The facility was reconstructed after its destruction during World War II, and was replaced in 1967 with completely new terminal complex called Schiphol Centrum. Its latest extensions were opened in 1975 bringing the total number of gates on its four piers to 42.

One of the most interesting features of this airport is that it was designed to accommodate many visitors, not just passengers. It not only contains the national aviation museum, but also has one of the biggest duty-free shopping centers in Europe. Also of interest to the visitor are the huge observation decks over the North and central piers which are directly accessible from restaurants and snack bars. In fact there has been substantial effort to develop the airport itself as a major tourist attraction.

As far back as 1929 the authority which ran the airport recognized the attraction it had to the general public and introduced a fee for admittance to the field and to conducted tours of the aircraft and facilities. Although the tours were discontinued in 1966, the number of visitors has remained approximately steady at 1.5 million annually since 1960.

FIGURE 4
Plan of Schiphol
Airport, Amsterdam
Source: Airport
brochure

FIGURE 5
View of major
observation deck
Source: Airport
brochure

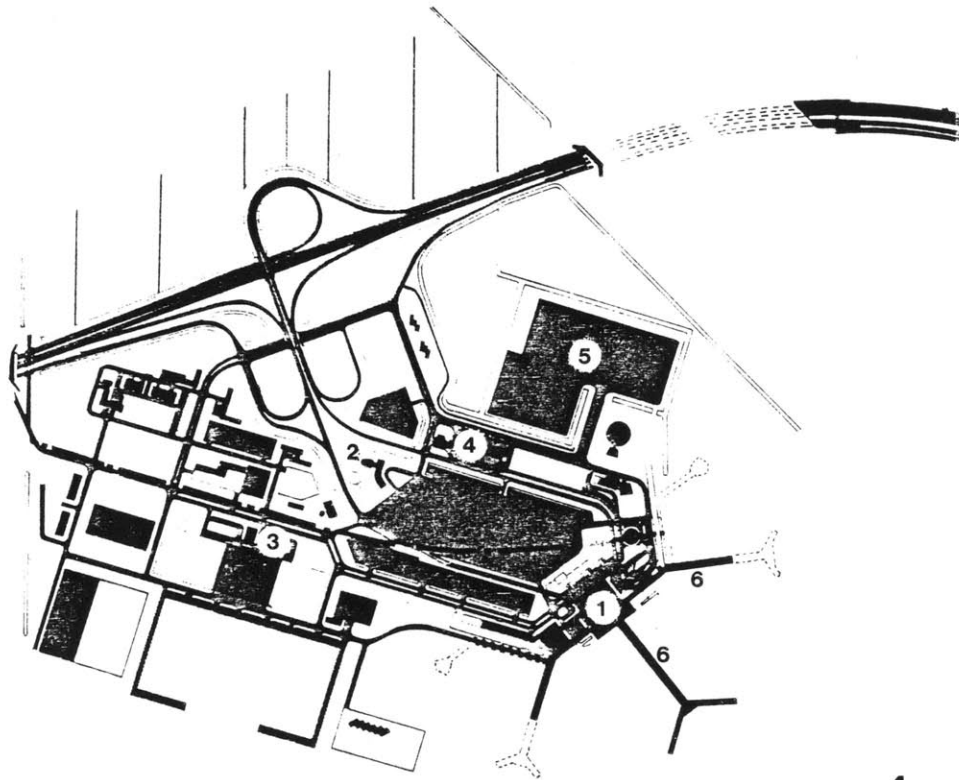

4



5

**CHARLES DE GAULLE AIRPORT (Roissy-En-France)
Paris, France**

Terminal type: satellite
Annual capacity: 12 million passengers

Key Features

- (1) Terminal building,
with 7 satellites
- (2) Concessions
- (3) Restaurant
'Drive-in' baggage check-in
Roof top panoramic concourse

The Aerogare 1 (terminal 1) of Paris's Charles de Gaulle Airport, formerly Roissy-en-France, was complete in 1974 as a major showcase of French technology and architecture. At that time the entire airport was built as a coherent package of modern and rather abstract architecture, including the terminal building, the central heating, air conditioning, and mechanical building, and the control tower, among other works.

The terminal building is 11 storeys tall, with the top five containing parking. The six lower levels are contain all of the passenger areas, including a fairly extensive if cramped shopping area, and are surrounded by the circular automobile ramps. The center of the building is hollow with tubes passing through the space containing the escalators that connect the levels. The intended atmosphere of the airport is obviously one of high technology, including such things as drive-in baggage check in, according the original design, which was done during the early days of the Concorde. The original plan provided for five such buildings, each with seven satellites, and a total annual capacity of over 50 million passengers.

*FIGURE 6
Plan of Aerogare 1
Charles de Gaulle
Airport, Paris
source: Blankenship*

*FIGURE 7
Plans and section
of Aerogare 1
source: Blankenship*

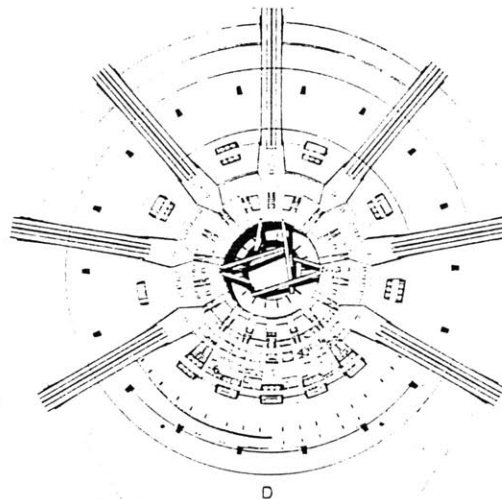
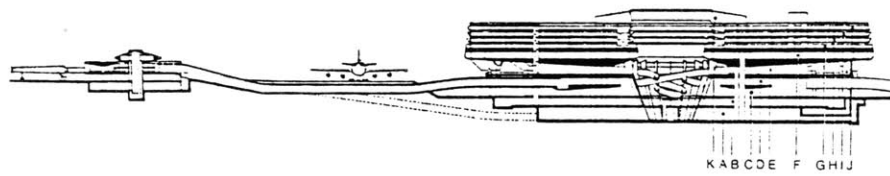
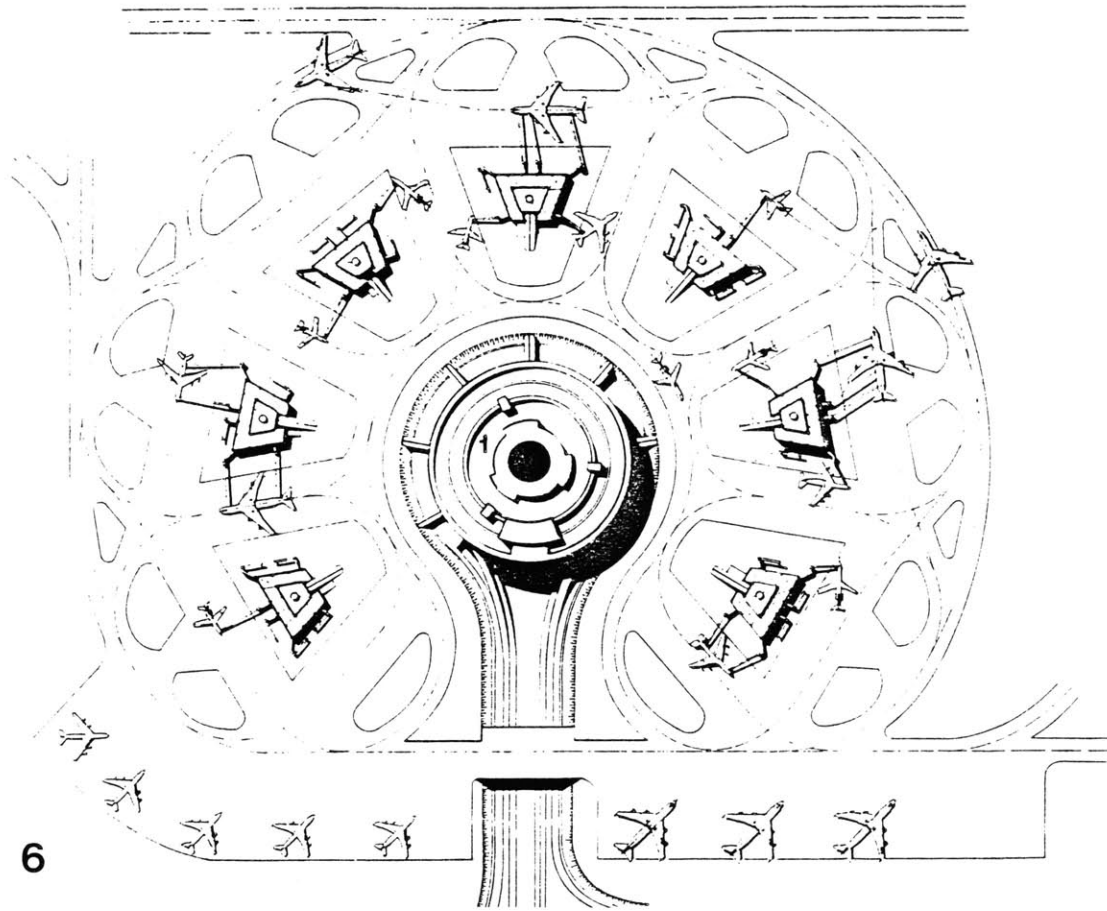

DALLAS/FORT WORTH REGIONAL AIRPORT
Dallas-Fort Worth, Texas

Terminal type: linear
Annual capacity: over 24 million passengers

Key Features

- (1) Terminal buildings
- (2) Parking
- (3) Terminal support areas
 - Museum of aviation
 - Spiritual center
 - Hotels
 - World trade center

The Dallas/Fort Worth Regional Airport has been billed as the world's most thoroughly planned airport. It encompasses 18,000 acres, and in the 2001 Land Use Plan includes 13 semi-circular terminals with a total annual capacity of over 50 million passengers. In addition to the key features mentioned above, this plan also contains an executive air terminal, an industrial airpark, and a huge air cargo facility. This airport has been designed as major commercial and industrial center serving not only the Dallas-Fort Worth metropolitan area, but a region covering many states.

It is yet to be seen if this extremely ambitious project will succeed, as currently there are only 4 operating passenger terminals. An intra-airport transit system connects the terminals, and a rapid transit system will provide transportation to the metropolitan area.

In the context of multiple uses, this airport certainly has more than enough to offer, but one wonders if this isn't overkill. The planned facility is so large in scale with everything so spread out that the passenger or visitor may be more aware of the industrial park atmosphere than anything else.

FIGURE 8
Dallas/FW 2001 plan
showing layout of
passenger terminals
source: Blankenship

FIGURE 9
Close-up of linear
terminal at Dallas
source: Blankenship

FIGURE 10
Partial airport plan
source: Blankenship

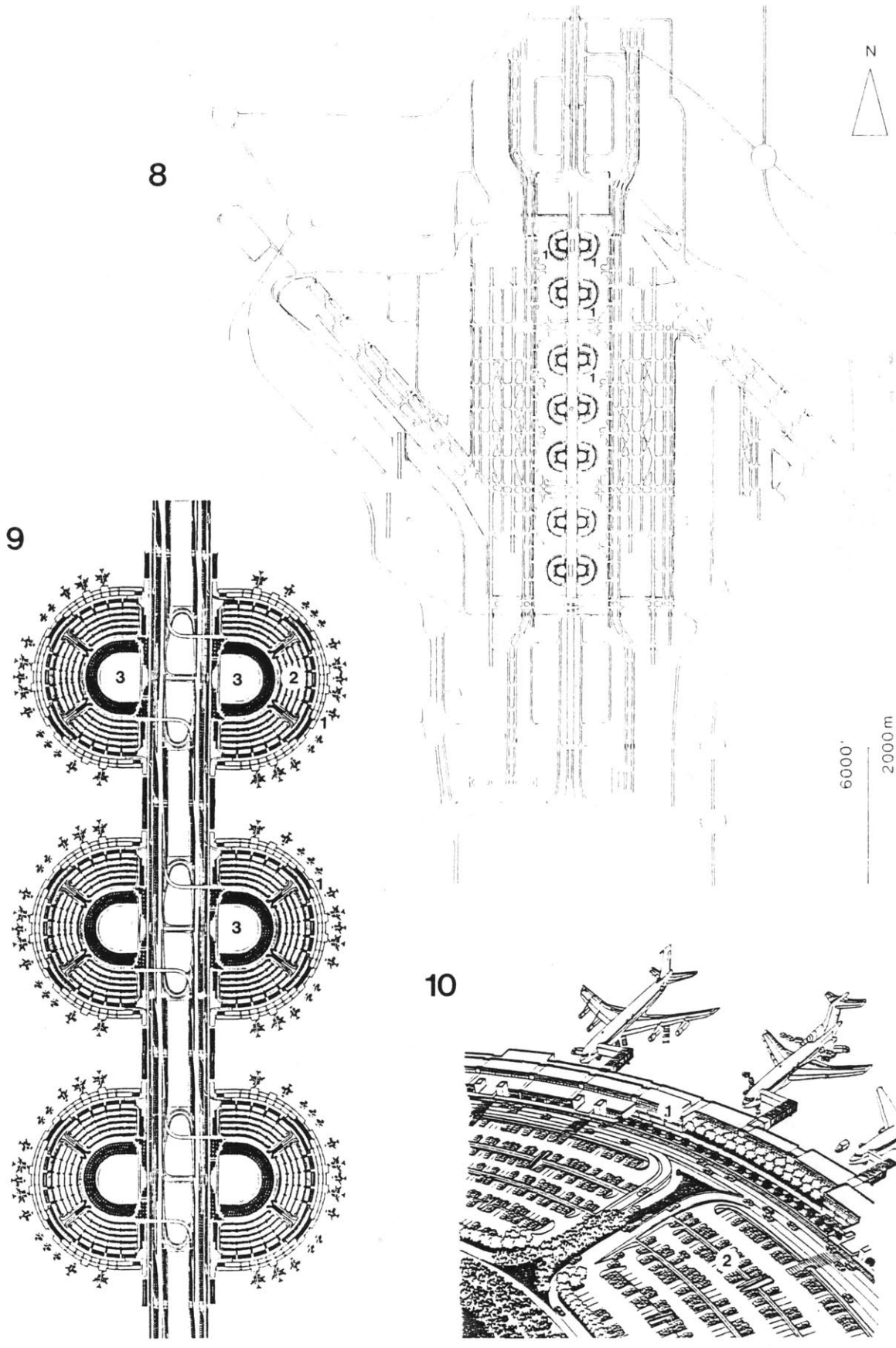

DULLES INTERNATIONAL AIRPORT Washington D.C.

FIGURE 11
Picture of Dulles
Airport terminal
source: Blankenship

Terminal type: remote

FIGURE 12
Plans and section
source: Blankenship

Key Features

- (1) Concessions
 - Hotel
 - Aeronautical museum (near future)

When Eero Saarinen designed Dulles International Airport he practically invented the mobile lounges which carry passengers from the terminal to the remotely parked aircraft. This concept and the image of the terminal building have been strong enough to influence people's view of this airport to the present. Dulles is also one of the few airports in the United States that has regularly scheduled flights with super-sonic aircraft. This and activities such as the annual air show, and the arrival of the space shuttle Enterprise attract many visitors and maintain the theme and image of modern flight.

Economically, however, Dulles has not been successful due to the low number of flights and passengers. This may be changing as a number of airlines, including some major ones, are increasing their service or establishing a 'hub' here.

In addition to these increases in passenger traffic, the National Air and Space Museum will open a facility at the airport that is three times bigger than the one in Washington. This museum will have hangars directly accessible from the taxiways to allow for a variety of exhibits to be brought in. There is a definite attempt to develop Dulles into a tourist attraction, as well as a major airport.

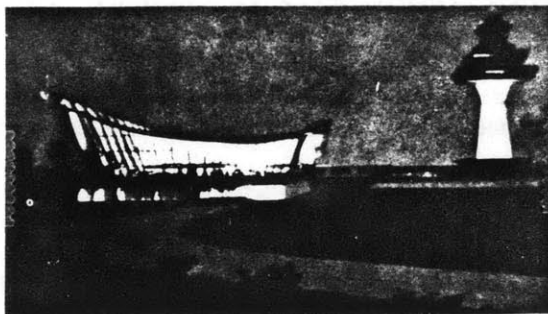

11

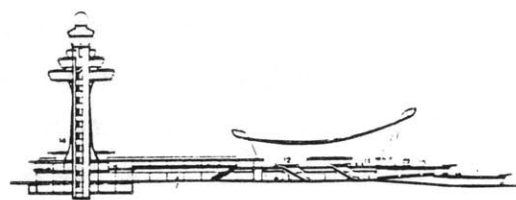

12

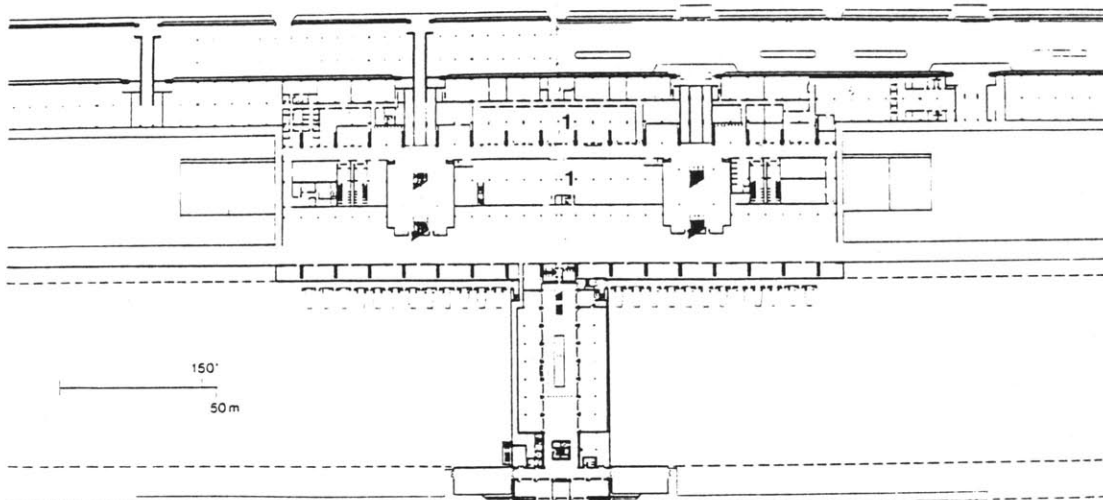
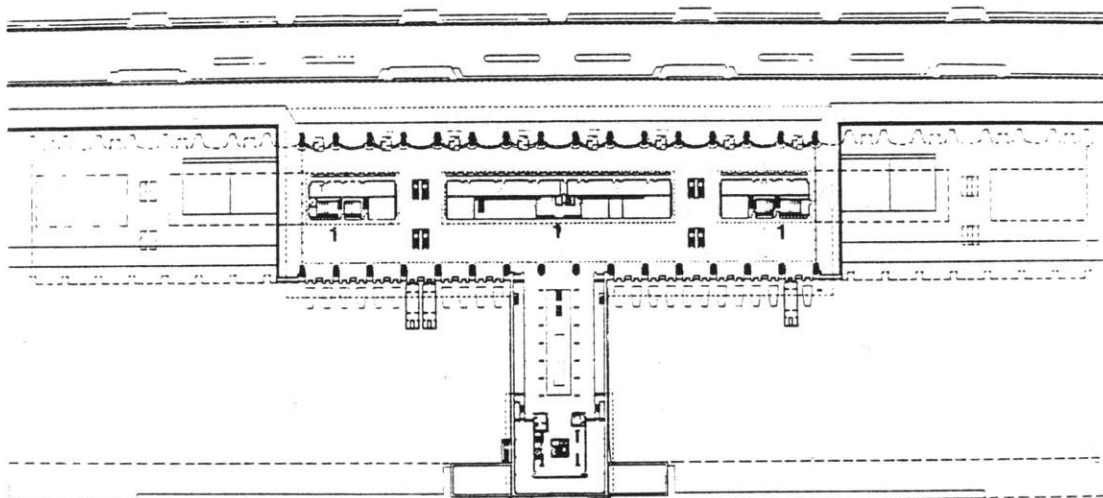

KING ABDUL AZIZ International Airport Haj Terminal, Jeddah, Saudi Arabia

Terminal type: special

Capacity: about 1 million, during a six week period

Key Features

- (1) Main international terminal
- (2) Haj Terminal, with a total of 10 modules
- (3) Fully enclosed part of module,
with most airport transactions
- (4) Open part with large resting areas

The purpose of the Haj Terminal of the Abdul Aziz International Airport is to accommodate the hundreds of thousands of pilgrims which fly to Jeddah then continue mostly by bus to Mecca. One major requirement is to provide shelter and facilities for these passengers during their 24 hour stay coming and 36 hour stay leaving Jeddah, thus practically turning the terminal into a short term hotel. The terminal can currently accommodate 80,000 people in 36 hours. It consists of ten modules, each handling 8,000 passengers. There are cooking, dining, resting, and commercial facilities in every module, along with taxi and bus areas.

The traffic flow at this terminal is very unique, with people starting to arrive two to three weeks before the Haj. The planes arrive full and leave empty, there are no transfer passengers. After the Haj, the reverse is true. The terminal is open only during the six week period around the Haj.

The impressive thing about this terminal is its local theme and very strong image. The structure covers 105 acres with 210 semiconical fabric roofs, in sets of ten separated by a service road. It is, in effect, a huge version of the traditional tents used in the desert, shaped to provide circulation and cooling, and built to be permanent. The result is massive but beautiful, and it seems to work.

FIGURE 13
King Abdul Aziz
Airport plan
source: Progressive
Architecture 2:82

FIGURE 14
Plan of Haj Terminal
source: Progressive
Architecture 2:82

FIGURE 15
Plan of one module
in the Haj Terminal
source: Progressive
Architecture 2:82

FIGURE 16
View of interior
of Haj resting area
source: Progressive
Architecture 2:82

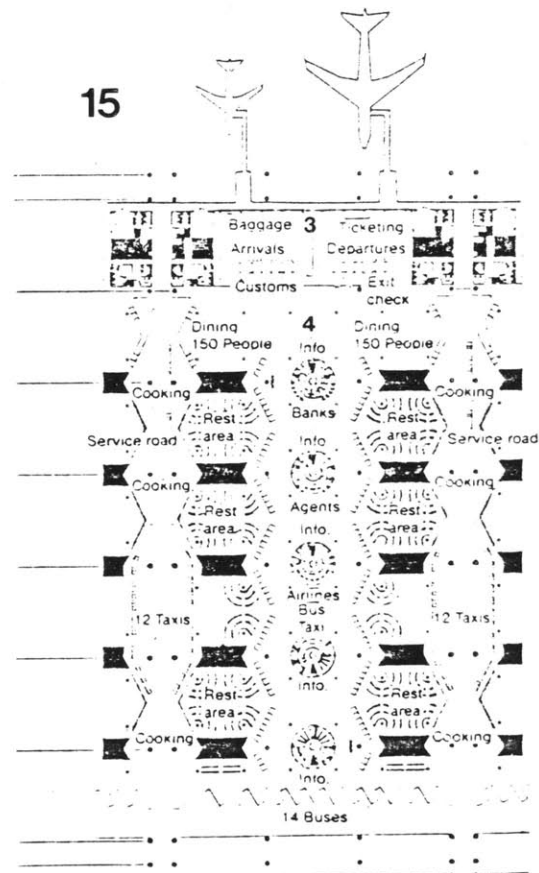
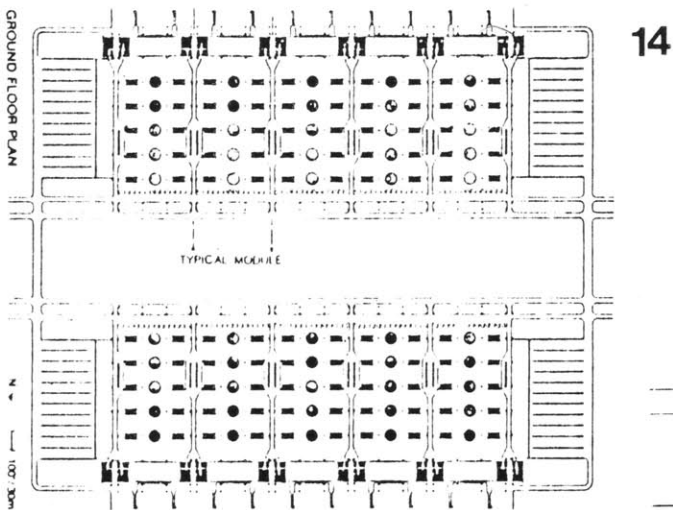
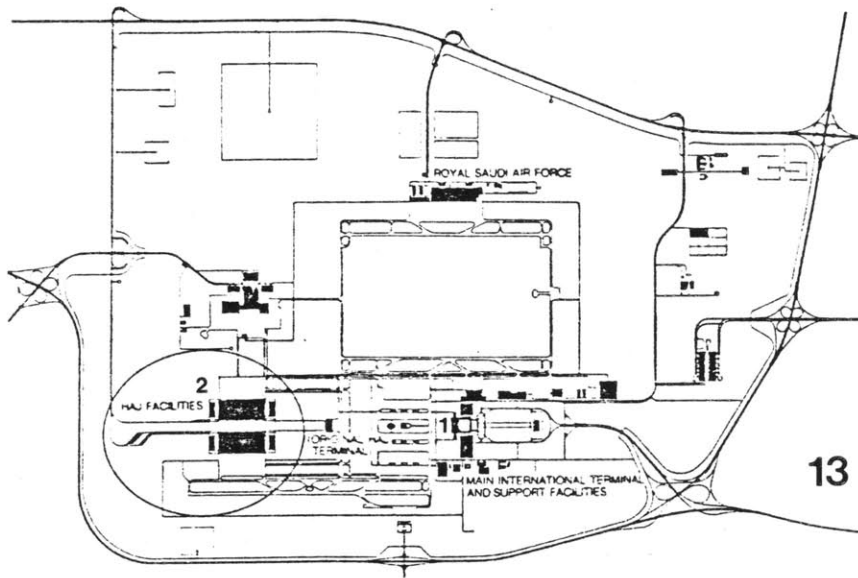

THE NEW MALPENSA TERMINAL

Airports at Milan: Malpensa and Linate

There are two commercial airports serving the Milan metropolitan area, Linate and Malpensa. The former is much closer to the city center and currently carries about six million passengers annually to mostly domestic and international destinations. Malpensa is about one hour from downtown Milan, and currently serves less than two million mostly intercontinental passengers annually.

The location of Malpensa is such that it could serve both Milan and Torino, as well as the region. This area of Italy has many industries, both light and heavy, ranging from the Fiat factory whose headquarters are in Torino, to the fashion centers in Milan. The products range from trucks and automobiles, to furniture, to high fashion clothing. As a regional airport Malpensa's meeting, conference, trade, and hotel facilities could easily be used as a convenient location for international transactions.

Milan has been experiencing an increase in passenger traffic demand, and it looks like this trend will continue. In fact the North Atlantic Traffic Committee has reported that Milan will have the fastest growth in intercontinental air traffic in Europe to the year 2000.

Milan's location in Northern Italy also makes it an ideal spot for a stopping point on long intercontinental voyages. For example, flights from the United States to central Europe, Africa or the Middle East, could make a stop here. For these passengers, the airport could be the place to introduce them to Italian culture and products. By maintaining a large number of shops in the terminal passengers could buy products not readily available at their destinations.

Congestion at Milan's main airport, Linate makes it impossible to handle a large increase in traffic

without expansion. Because of its proximity to the city, a major expansion of Linate would be very costly and would probably find substantial public resistance.

Malpensa, on the other hand is located in a rather remote area with plenty of room for expansion. It is not as convenient to get to, but the difference in extra distance may negligible for passengers of longer flights.

The proposed plan is to move all intercontinental and most of the international flights to Malpensa and to use Linate almost exclusively for domestic flights.

Studies based on passenger traffic simulations show that about 12 million people will be using Malpensa annually by the year 2000. As the detailed numbers show in Appendix A, Alitalia carries almost half of the total passengers. According to the projections, Alitalia's traffic is mostly international with intercontinental not far behind and domestic flights a distant third. Other airlines carry almost four times as many international passengers as they do intercontinental. This mix, though, is certain to change, so flexibility in the design must account for wide deviations.

*FIGURE 17
Map of the area
around Milan
Showing the location
of Malpensa Airport*

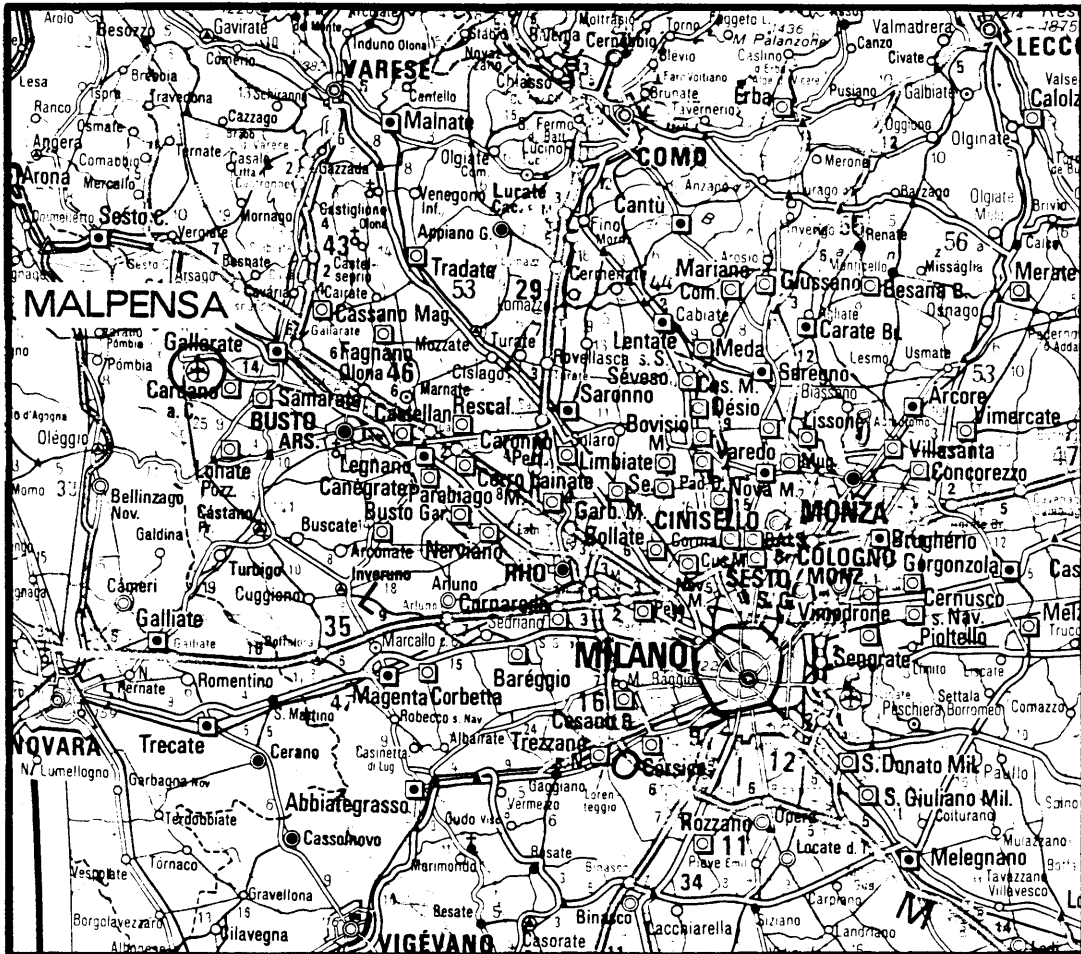

Airport Theme

The Galleria Vittorio Emanuele II

The generating theme of this new design for Malpensa comes from a landmark in the center of Milan, the Galleria Vittorio Emanuele II. The Galleria is a four-storey high arcade of shops and offices, covered by a glass barrel-vault and a glass cupola. It is located at the heart of the city, with its grand entrance on the north side of the Piazza del Duomo and its main axis leading to the Piazza della Scala.

The Galleria's realization goes back to the unification of Italy and the liberation of Milan in 1859. By 1860, there was a public competition for the design of a grand plan to enlarge the Piazza del Duomo and to connect it to the Piazza della Scala. Over 200 projects were submitted that year, but the city commission responsible for the selection was unable to come to a conclusion. Furthermore, the competition did not raise enough money to proceed immediately. In 1862, another competition was arranged, this time open only to 18 invited participants. They could choose between a "Heavenly Way covered with a portico" and a "glass covered way." By the end of the year and after much debate the winner was selected and the plan was worked out. Construction began in 1865 and the Galleria was completed in 1867.

The arcade has since been the scene of a wide variety of events in the history of Milan, from demonstrations protesting the arrest of Garibaldi in 1867, to the daily activities of the present. There are seven storeys, including the cellar and the top floor which is above the the arcade space, containing a total of 1260 rooms. The ground floor and mezzanine are both occupied by shops of all sizes, showrooms, cafes, and

FIGURE 18
Plan of Galleria
Vittorio Emanuele II
in Milan
source: Geist

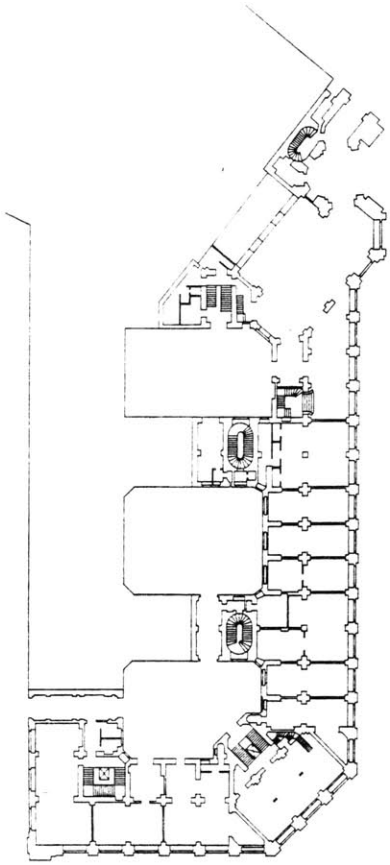

18

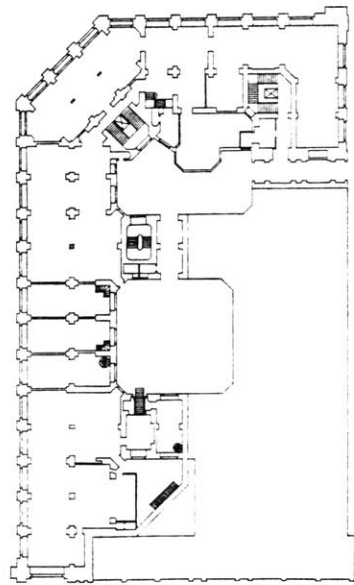
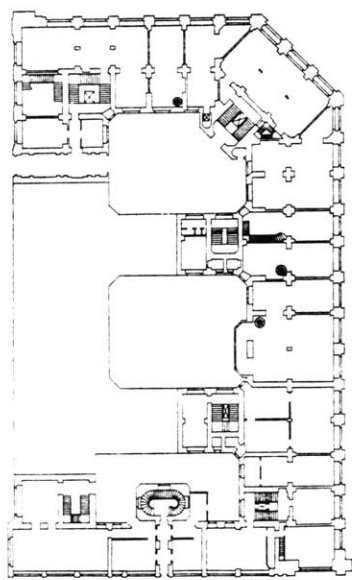
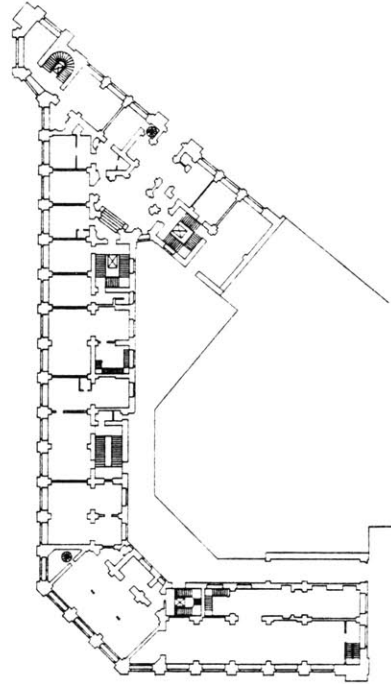

restaurants. The third floor is occupied by clubrooms, offices, and studios, and the remaining are residential.

The principle dimensions of the Galeria are: longitudinal wing, 645 feet; lateral wing, 345 feet; diameter of rotunda, 120 feet; concourse width, 48 feet; height of vault, 96 feet; and the height of the dome is 137 feet.

*FIGURE 19
Plan showing
location of Galeria
next to Piazza del
Duomo
source: Geist*

*FIGURE 20
Entrance facade
on Piazza del Duomo
source: Geist*

*FIGURE 21
Interior view of
Galeria
source: Barr*

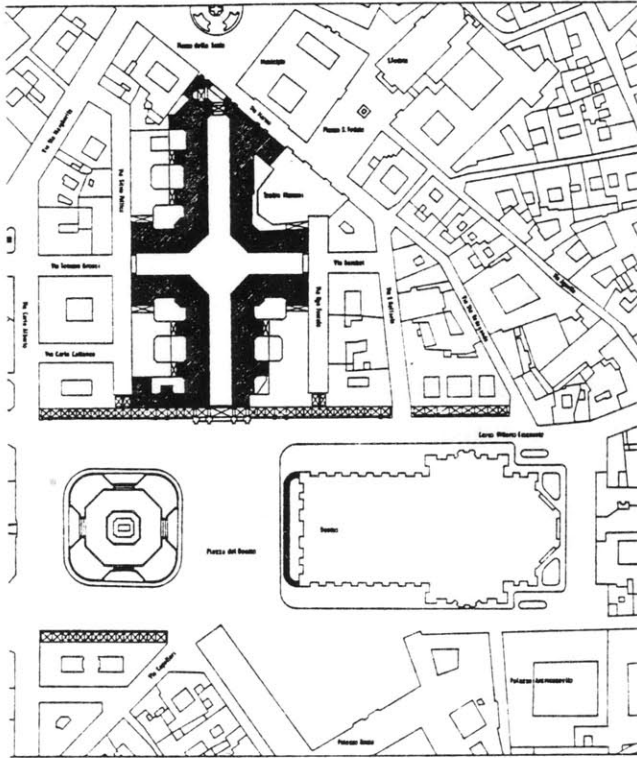

19

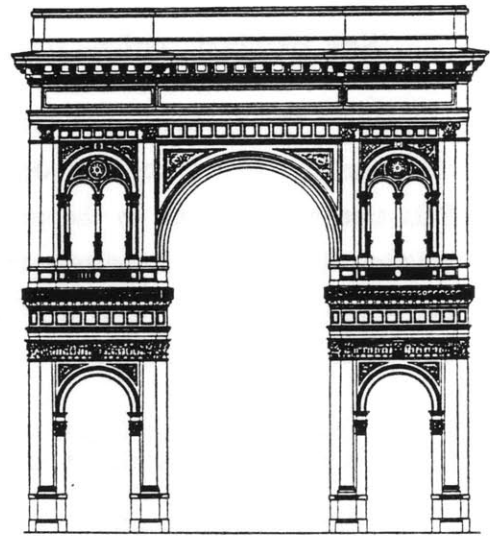

20

21



DESCRIPTION OF THE NEW TERMINAL

New terminal configuration

The proposed new terminal has three satellites all accessible from a common departure holding area. This area will be open to the remainder of the terminal building since passport controls and security will be performed before the entrance to the satellite concourses. The three satellites accommodate the following flights:

- (A) international flights by airlines other than Alitalia, 9 gates (DC-9 size aircraft)
- (B) all intercontinental, 7 gates for wide body jets
- (C) all Alitalia international and domestic flights, 9 gates (DC-9 size jets, plus ground access to 5 ART-42 aircraft for domestic flights)

Although the new building can accommodate current conditions, the assumption has been made that duty-free shopping will be available only to intercontinental passengers. It was decided that all the shops at the terminal will be accessible to the public but will offer duty-free prices only to intercontinental passengers, who can pick up their purchases at the gate. Some more conventional duty-free facilities will be provided, however at satellite A.

Functional description of levels

There are six levels to the main building, they are functionally divided as follows:

- 4th (top) floor: meeting and conference rooms, exhibit spaces, restaurants and additional food services, access to hotel and observation decks.
- 3rd floor: departures (enplaning) access road, ticket and check-in counters, shops along the arcade, and access to the hotel.

2nd floor: access to satellites and to the the hotel, shops, departure holding area, and baggage handling facilities for incoming and outgoing baggage. Transfer baggage will be taken care of at the satellites.

1st (ground) floor: arrivals (deplaning) access road, baggage claim areas, car rental offices and other travel services, main hotel lobby and entrance, bus departure terminal, taxi facilities, and access to the underground train station.

1st underground floor: parking, and delivery and storage for shops and food services.

2nd underground floor: parking and train station.

Types of passenger controls

Passport: passport control is handled by government authorities, and is a way of keeping some track of who comes into or leaves the country. It is usually more important to check the passengers that are entering in order to make sure they have the appropriate visas (if necessary) or other papers. Passport control for arrivals is most often located before passengers reclaim their baggage. For departures, passport control is often located before entering the departure holding area.

Customs: this is also handled by government officials. Italy, as most countries, imposes a duty fee on imported goods. Customs facilities are where passengers declare these items, officials search and inspect them, and charge the appropriate fees. Customs facilities are always located after passengers have picked up their luggage and usually after passport control.

Security: this is a check to detect weapons and other potentially dangerous items on or with departing passengers. It can be handled by government, airport, or airline personnel, or a combination. It has traditionally been located immediately before the departure lounge, or in the case of a satellite, just before

its entrance. However, with the increasing problems at airports, there is pressure to have multiple levels of security checks.

Types of flights

There are three categories of flights, as outlined in the traffic projections by ItalAirport. They are defined here, as they may differ from convention and may also involve differences in passenger processing procedures:

Domestic: flights solely within Italy. All domestic flights to and from Malpensa are by Alitalia.

International: flights leaving or entering Italy from another European country, even if they include a leg within Italy.

Intercontinental: flights to or from destinations outside of Europe, even if they include a leg within Italy.

For example, if a passenger arrives at Malpensa on a non-stop flight from New York and continues on the same flight to Rome, he will pass frontier controls at Rome and is considered a passenger on an intercontinental flight until then. Similarly with international flights. The same is true in reverse, for those who leave Rome, stop in Milan and continue to New York on the same flight. They go through passport control in Rome and are considered to be on an intercontinental flight from that point. This means that theoretically people cannot be allowed to fly only on the domestic leg of international or intercontinental flights because it involves frontiers controls, although in current practice this is permitted.

The differences in flight types involve the kinds of frontier controls that passengers must pass before they are allowed to board the plane or enter the

country. All passengers must be checked for weapons at the security station. International and intercontinental passengers must go through passport and customs control. Domestic passengers do not pass through either of these.

Another difference in frontier control is the current availability of duty-free shops to international and intercontinental passengers. In Europe these facilities are usually provided after passport control to departing passengers, allowing them to purchase goods without paying that country's value-added-tax. There has been talk by the European Common Market countries to eliminate duty-free shopping for inter-European air passengers. This would leave only intercontinental air passengers with the option to buy duty-free goods.

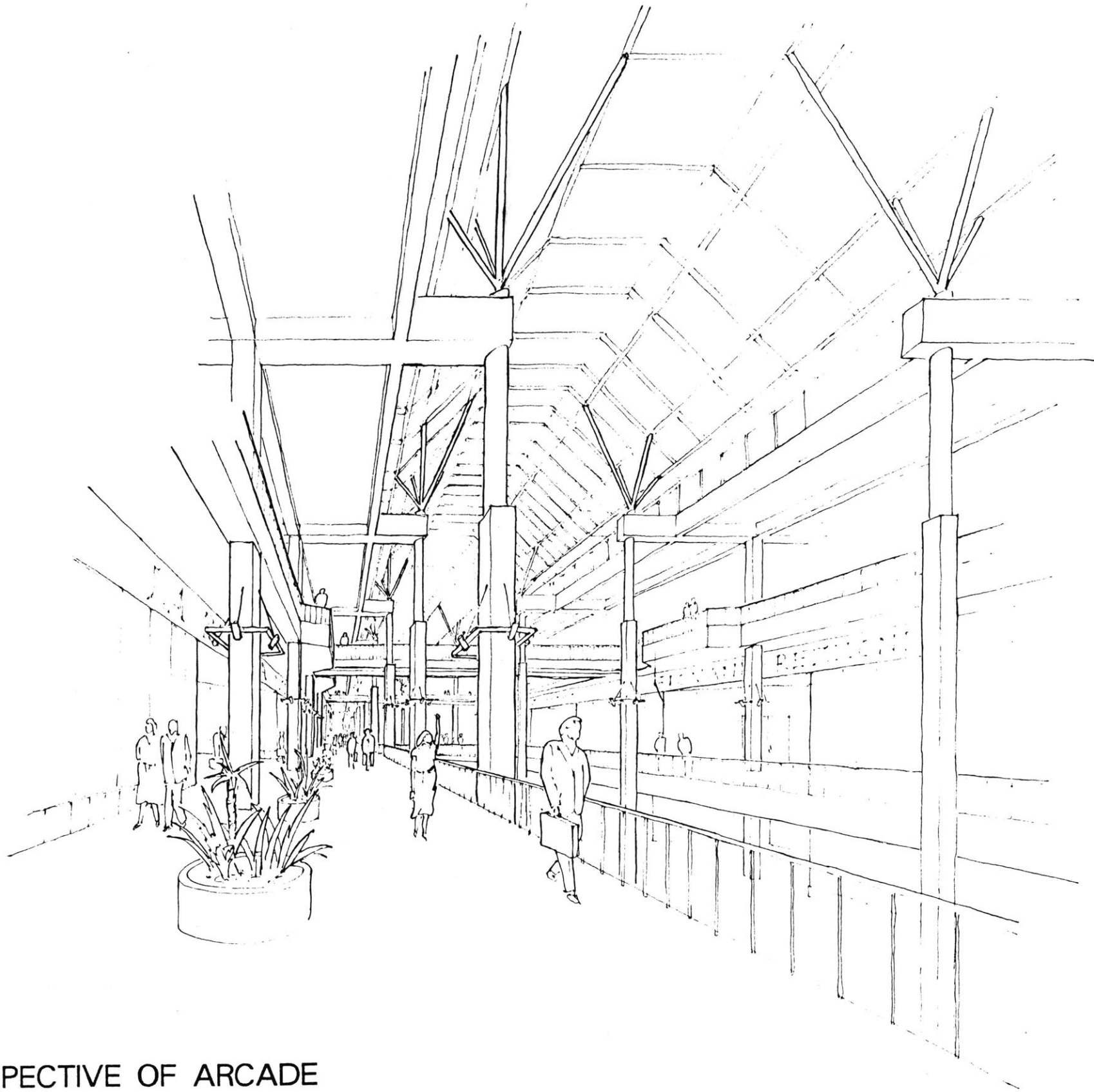

INTERIOR PERSPECTIVE OF ARCADE

KEY TO AIRPORT PLAN

Passenger Area

1. Passenger Terminal Building
2. Underground railroad station
3. Hotel

Cargo Area

4. Cargo terminal building
5. Forwarders (cargo handlers)
6. Post offices cargo facility
7. Live animals facility

General

8. Central mechanical station
9. Area for support of mechanical and technical services
10. Long term parking
11. Electric substation and transformer
12. Heliport
13. Water pumping and distribution station
14. Control tower and Italian aviation authority
15. Ramp equipment support area
16. Fire station
17. Aircraft maintenance area
18. Central kitchen
19. Catering
20. Headquarters for Milan airport authority (SEA)
21. Maintenance area and warehouse for SEA
22. Hostelry
23. Additional support building
24. Old terminal area "Malpensa Nord"
25. Technical zone for aircraft
26. Fuel tank farm
27. Fire house
28. Isolated aircraft parking
29. Incinerator
30. Area for future expansion of airport related industry

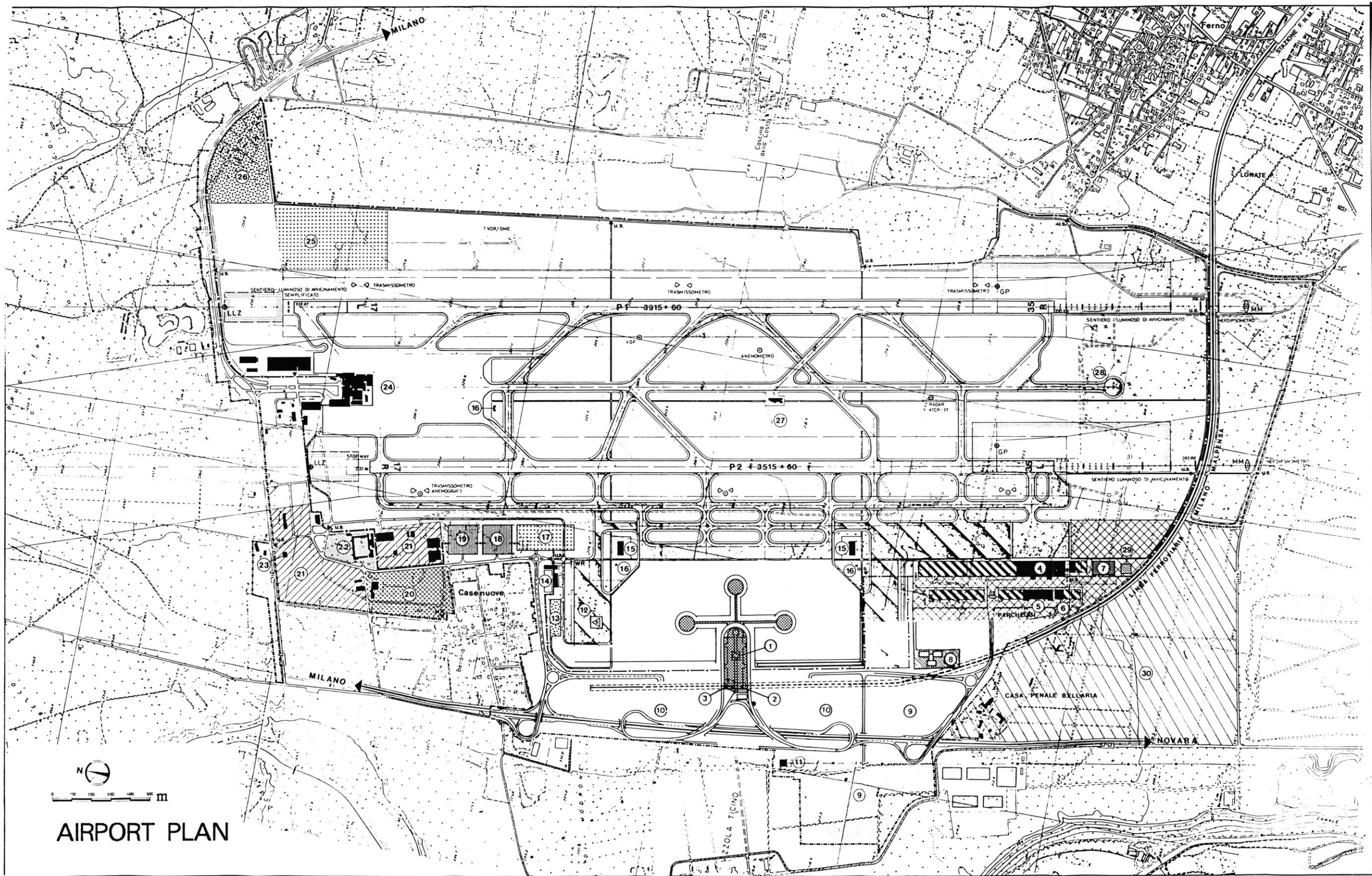

AIRPORT PLAN

KEY TO SECTION

1. Arrivals access roadway
2. Departures access roadway
3. Baggage vehicle roadway
4. Parking
5. Parking
6. Storage and delivery area
7. Baggage claim area
8. Shops
9. Baggage handling facility
10. Ticket lobby
11. Shops
12. Meeting rooms

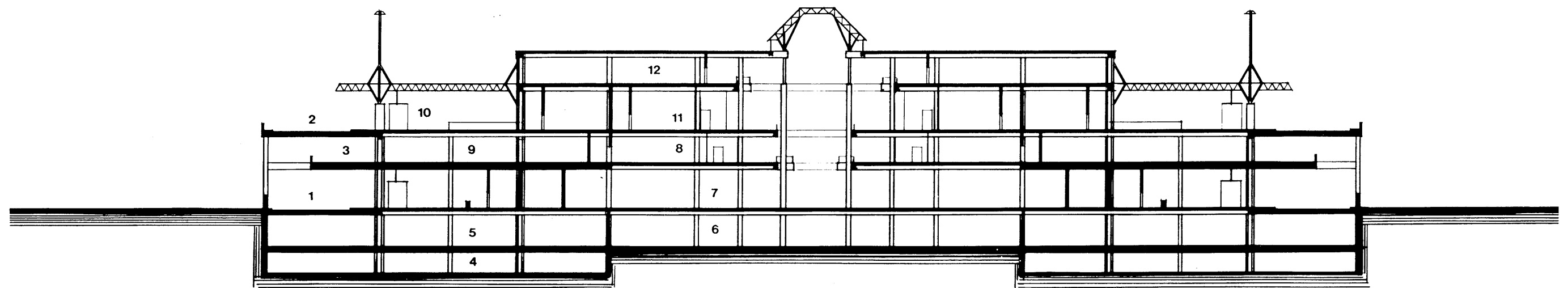

NORTH-SOUTH SECTION

SCALE 1" = 50'

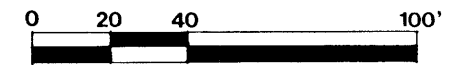

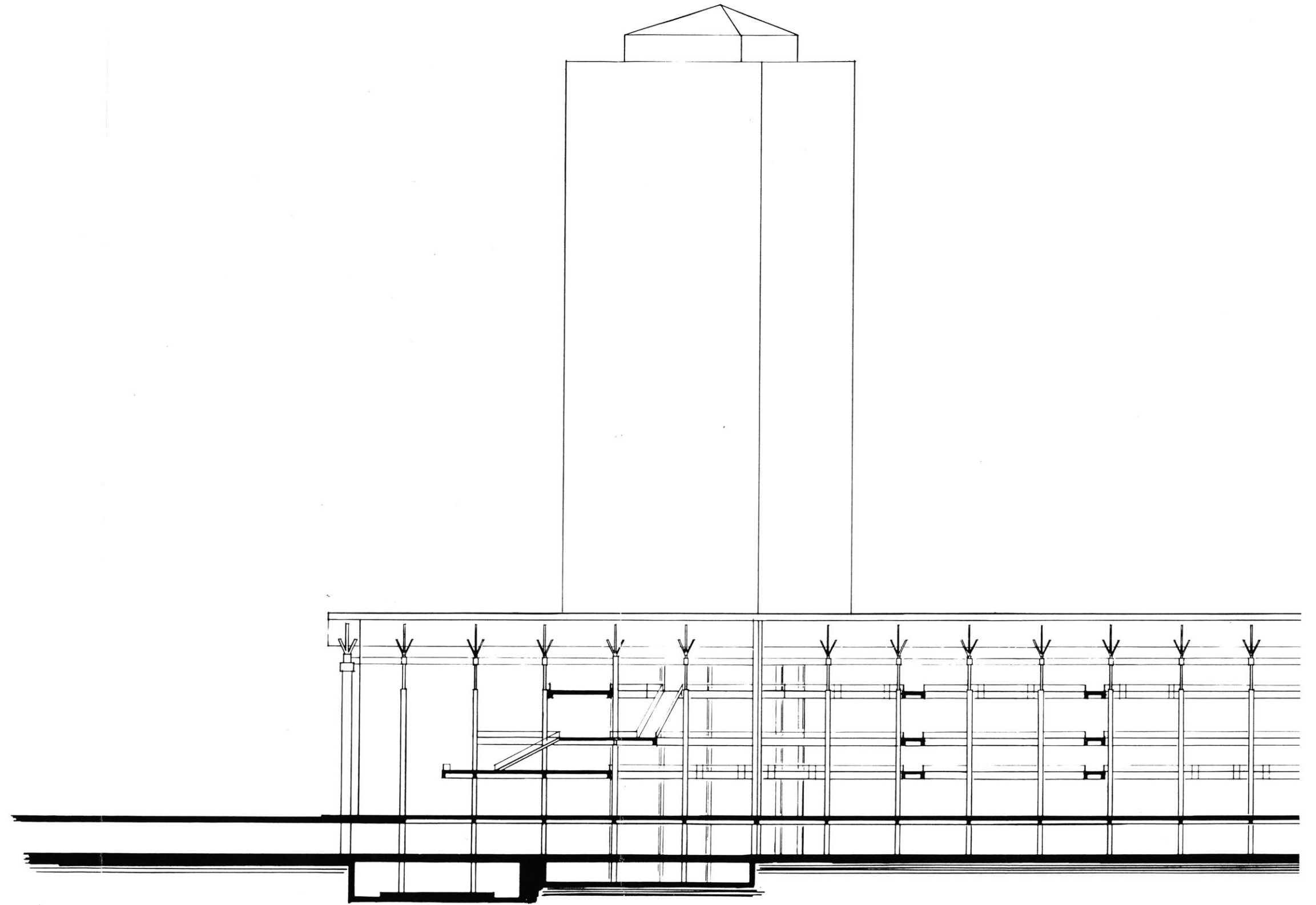

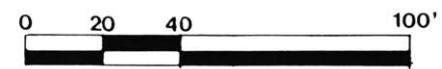
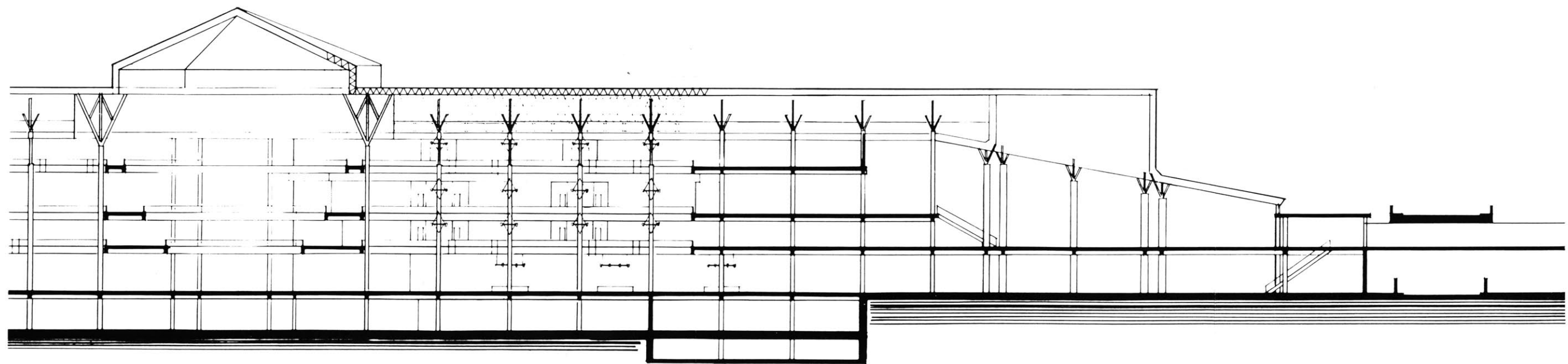

EAST-WEST SECTION



SCALE 1" = 50'

KEY TO ARRIVALS LEVEL, For deplaning passengers

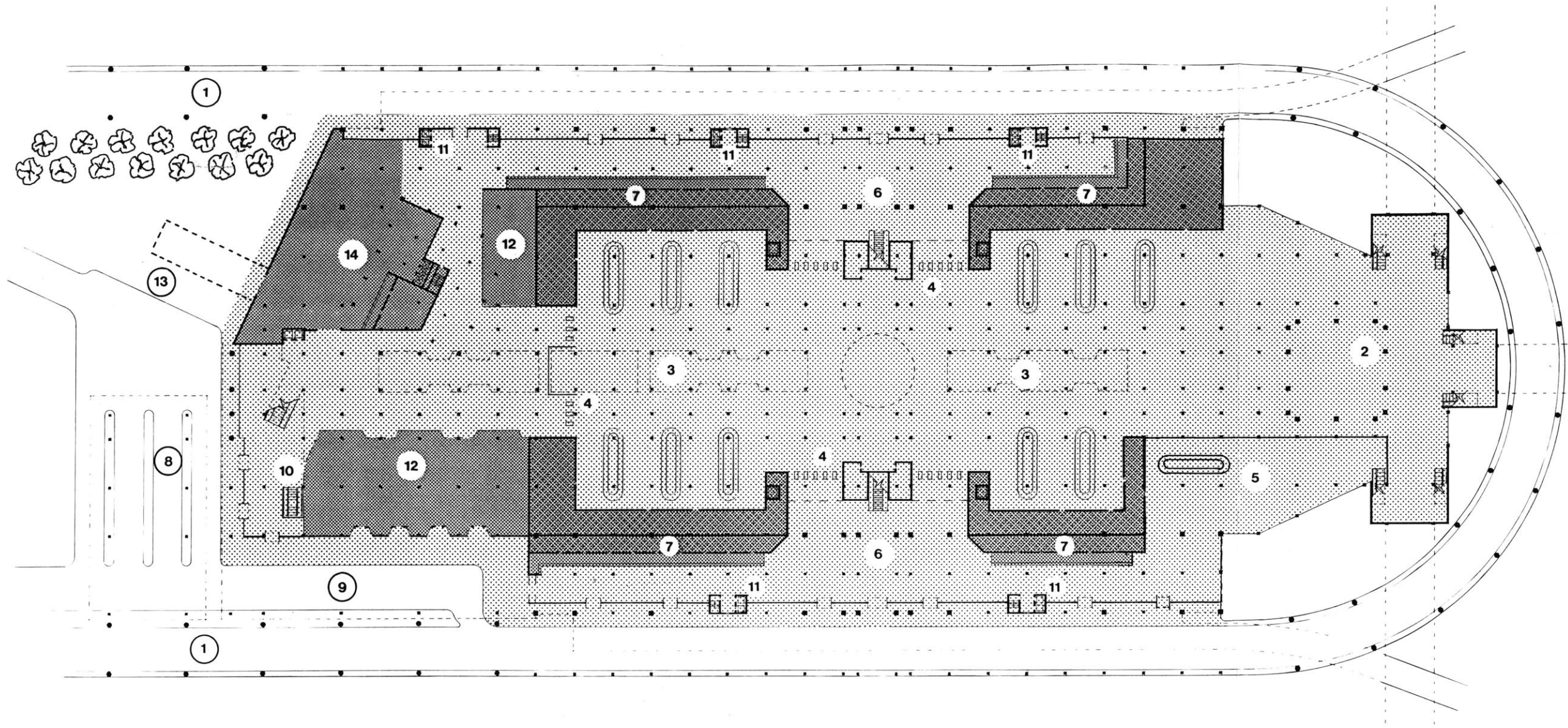
1. Deplaning access road
2. International and intercontinental arrivals lobby,
with passport control
3. Baggage claim for international and intercontinental flights
4. Customs inspection
5. Domestic arrivals lobby and baggage claim area
6. Greeters area
7. Counters and offices for car rentals and other travel services
8. Bus departure terminal
9. Taxi stand
10. Access to underground railroad station
11. Elevators to all levels including parking
12. Shops, restaurant, and cafe
13. Hotel curb
14. Main hotel lobby



ARRIVALS LEVEL SCALE 1" = 100'

-  PUBLIC CIRCULATION
-  COMMERCIAL OR PASSENGER SERVICE AREA
(includes areas of limited access)
-  OFFICE AND SUPPORT SPACE
(restricted access)

KEY TO INTERMEDIATE LEVEL, Shopping and satellite access

1. Departures holding area
2. Concourse to satellite A:
 all intercontinental flights
3. Concourse to satellite B:
 international flights of all airlines except Alitalia
4. Concourse to satellite C:
 Alitalia domestic and international flights
5. Security
6. Passport control
7. Baggage handling facilities
8. Baggage vehicle access road
9. Offices
10. Shops and other commercial space
11. Cultural exhibit spaces
12. Hotel lobby
13. Access to upper and lower levels

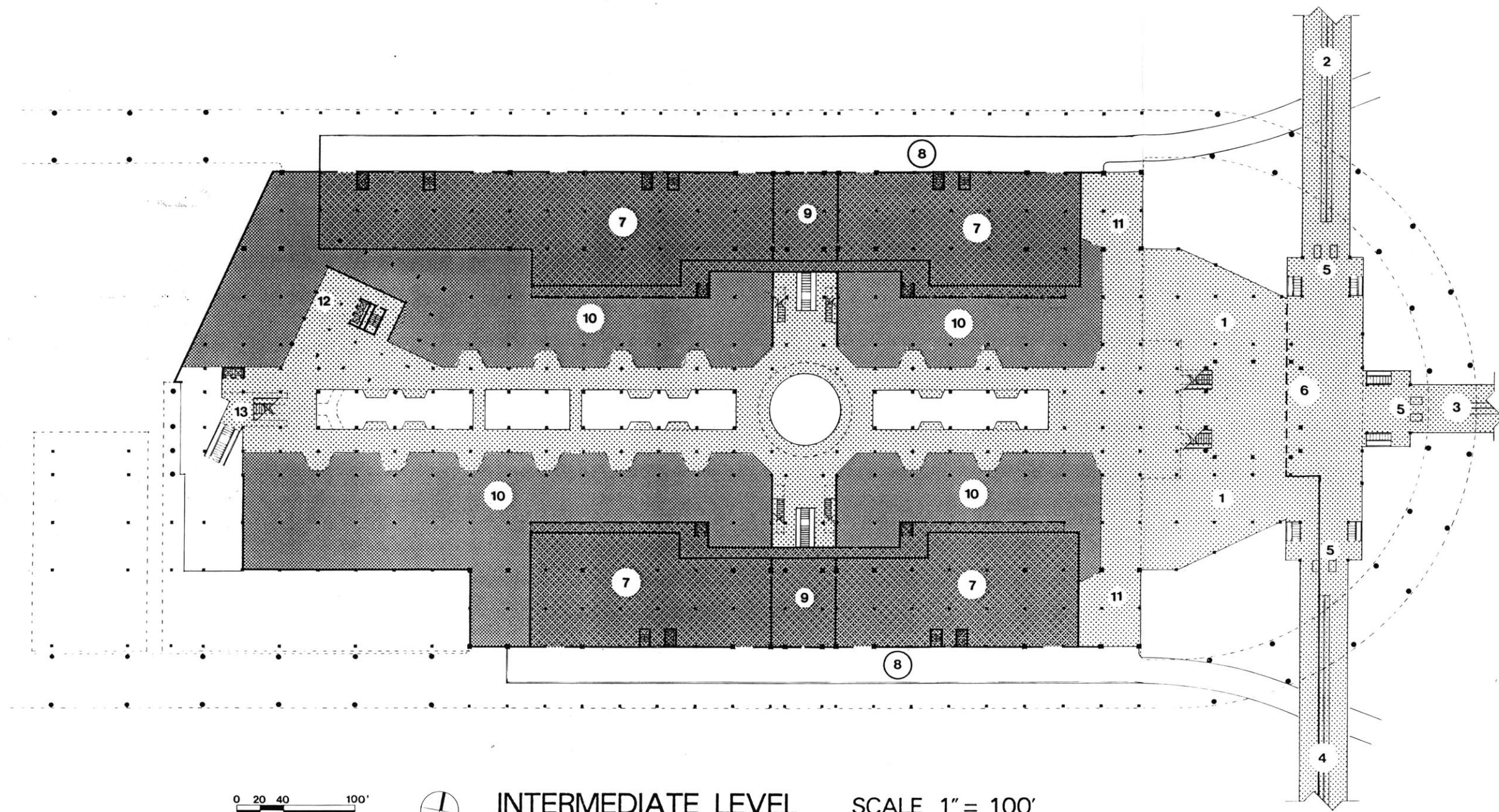

INTERMEDIATE LEVEL

SCALE 1" = 100'

KEY TO DEPARTURES LEVEL, For Enplaning Passengers

1. Enplaning access road
2. Curb for enplaning passengers of all airlines except Alitalia
3. Curb for Alitalia flights
4. Ticket counters for all airlines except Alitalia
5. Ticket counters for Alitalia flights
6. Airline ticket offices and support space
7. Access to departures holding area below
8. Shops and other commercial spaces
9. Access to hotel
10. Hotel lobby
11. Access to lower levels, leading to bus departures terminal
and to railroad station
12. Elevators to all levels including parking

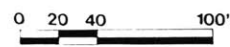
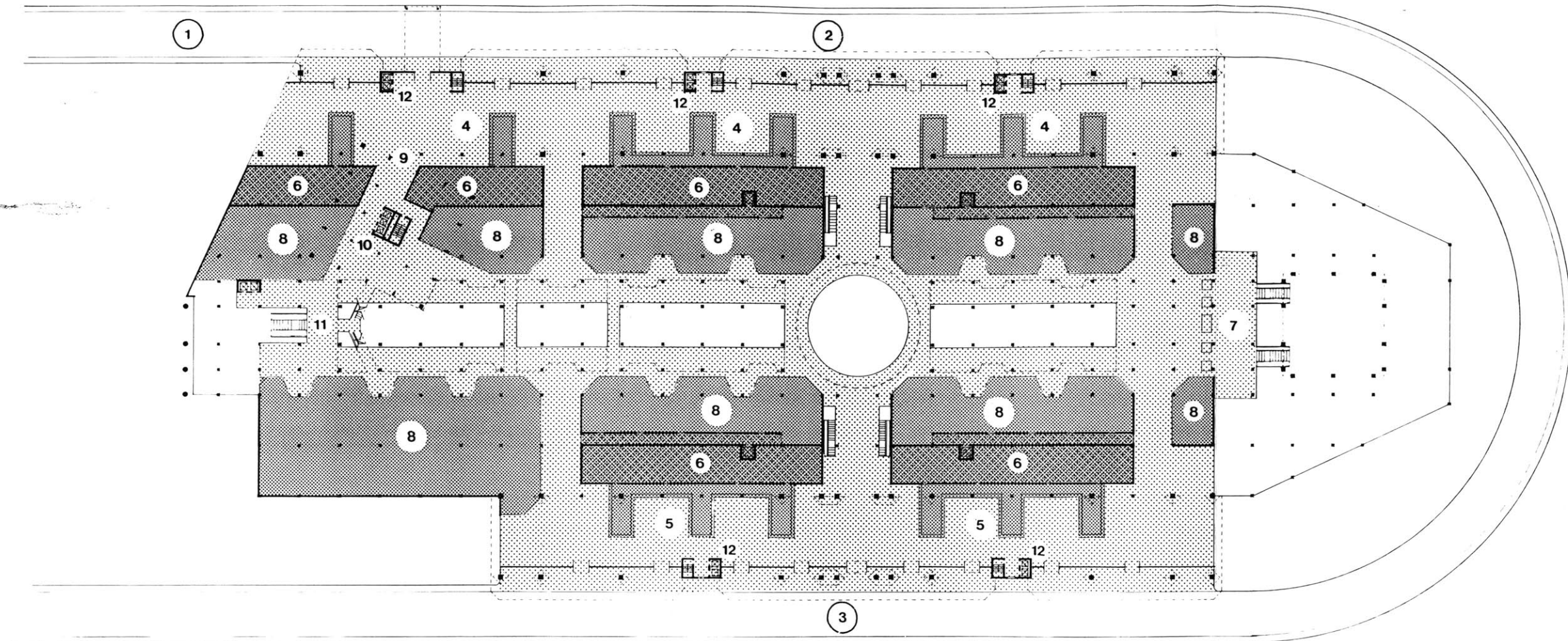

DEPARTURES LEVEL

SCALE 1" = 100'

FIGURE 22
*Photo of model
View of approach
from the north*

FIGURE 23
*Photo of model
View from airport
entrance*

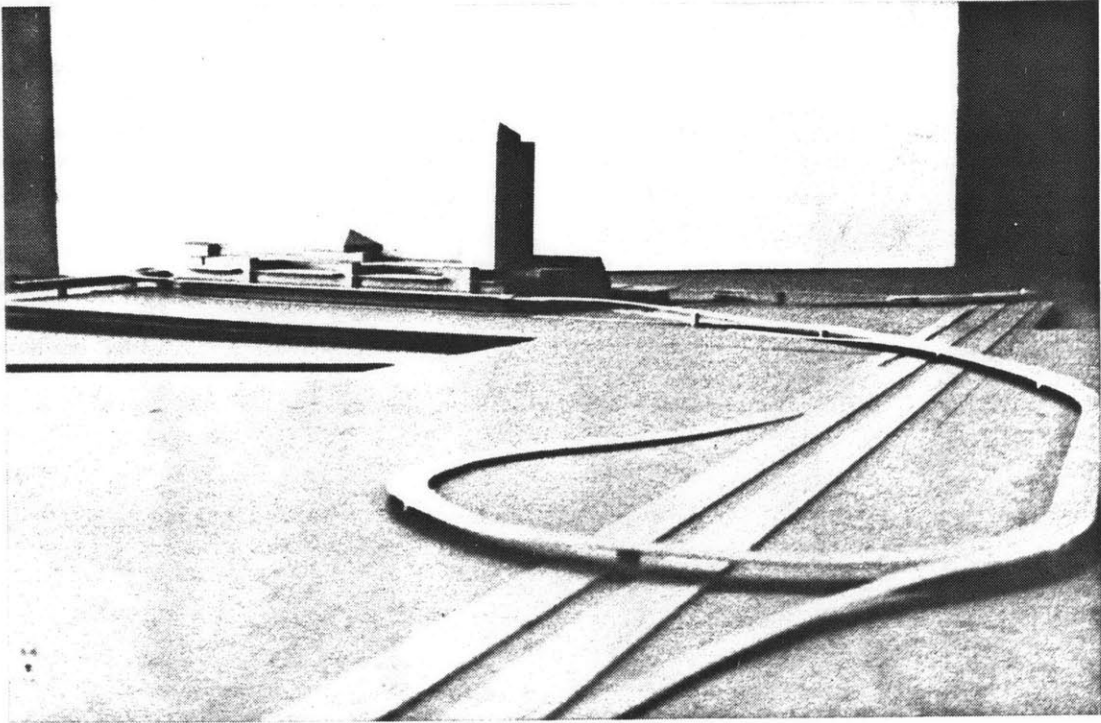

22

23

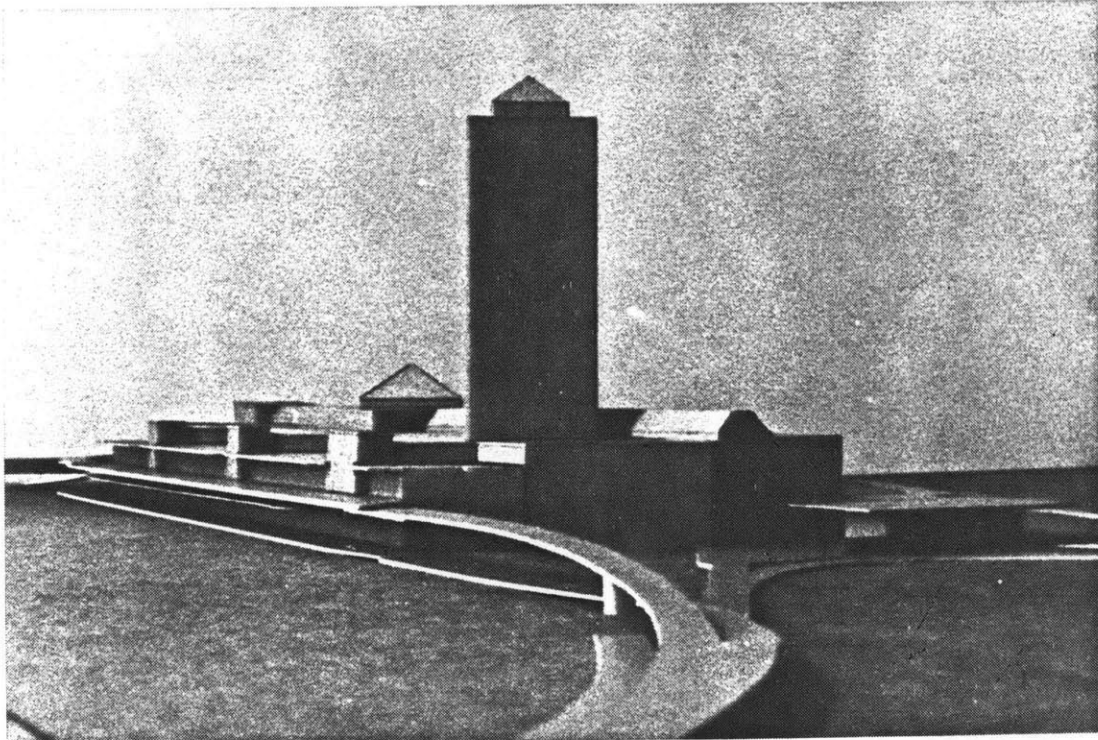
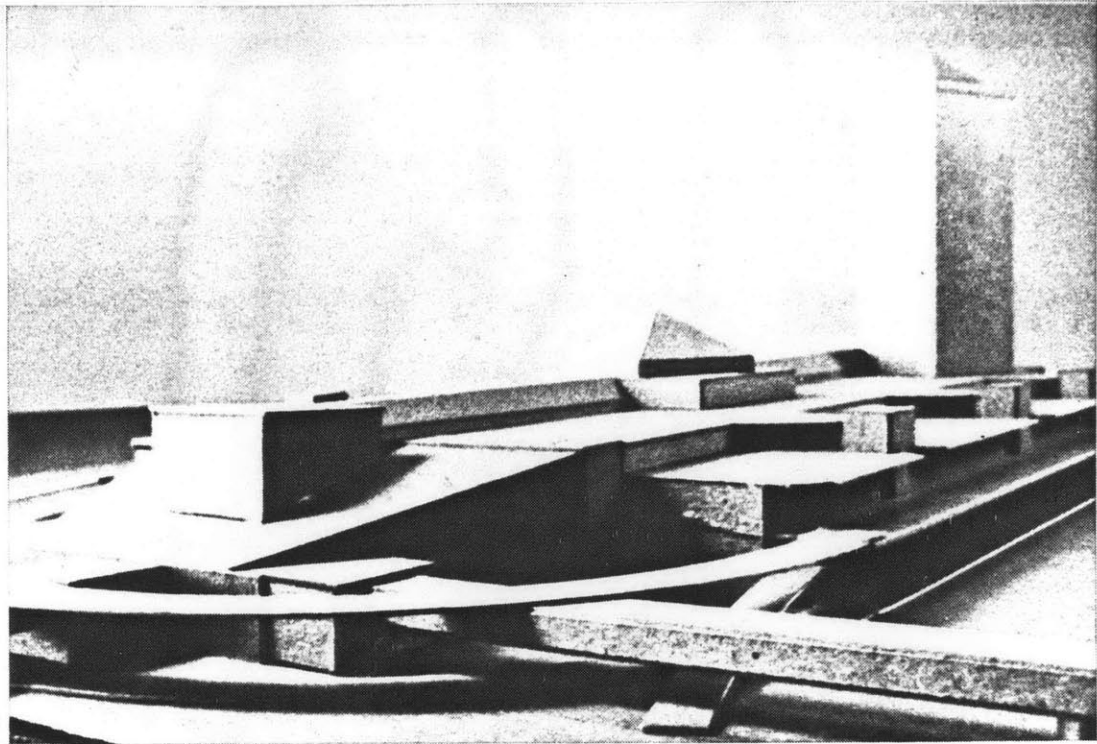

FIGURE 24
Photo of model
View of main holding
area, departures,
arrivals, baggage
roadways, with
concourse to
satellite A

FIGURE 25
Photo of model
Aerial view from
the north-west



24

25

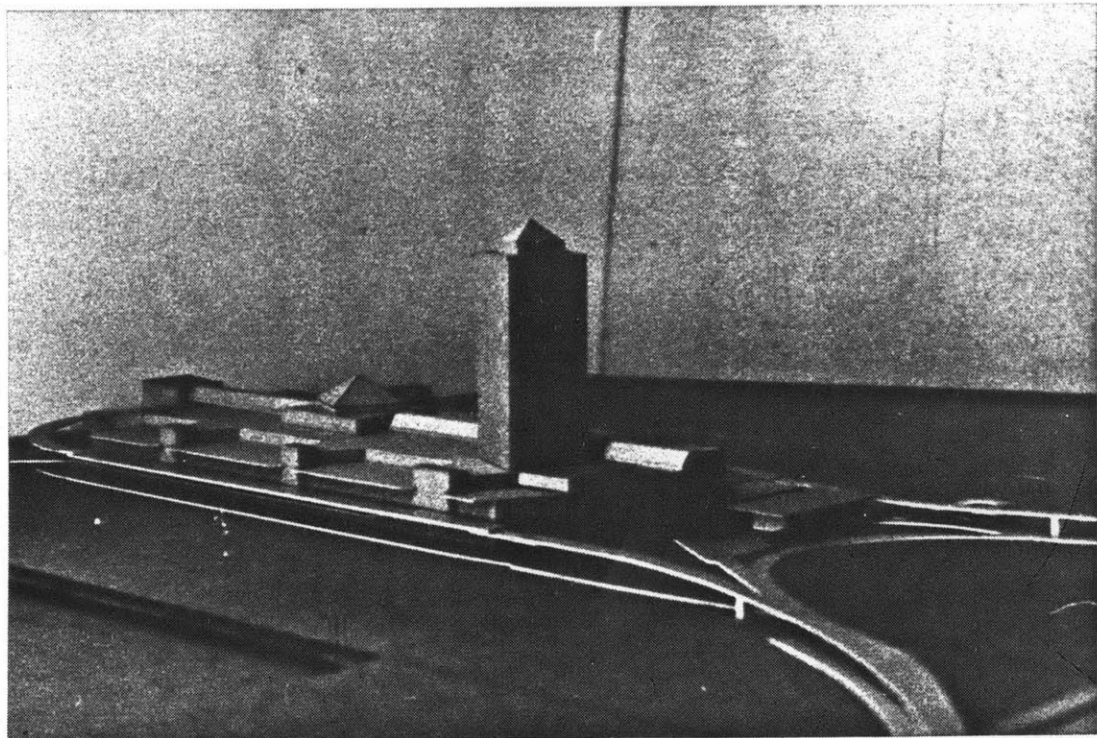
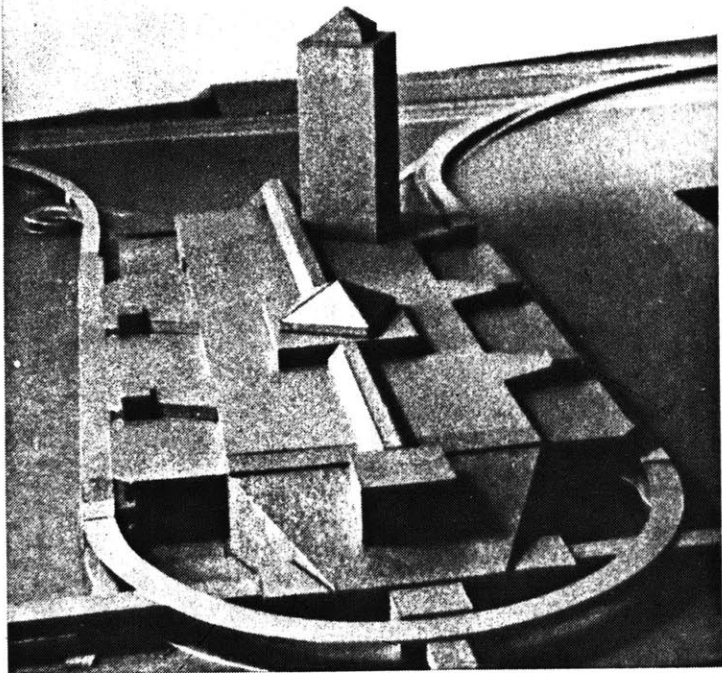
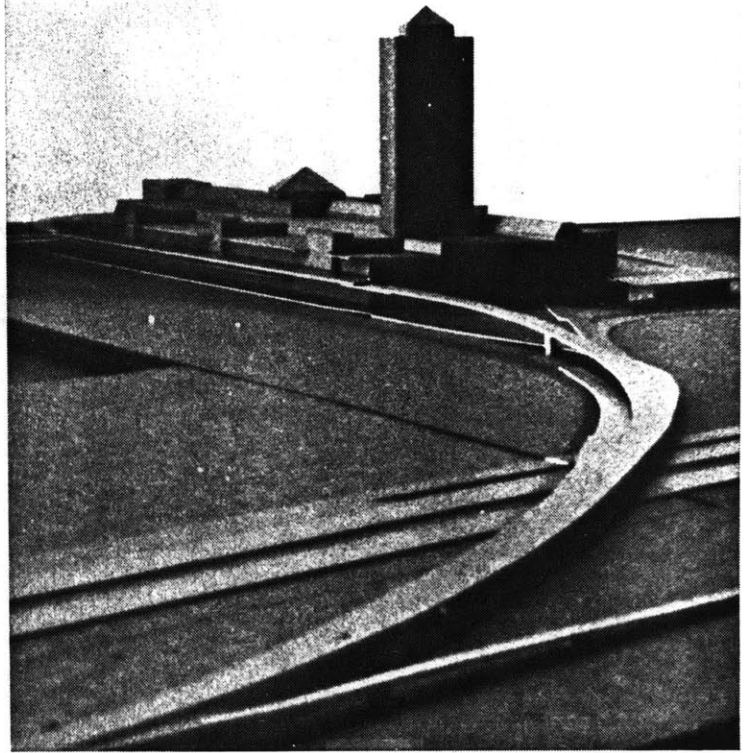

FIGURE 26
Photo of model
View over entrance
roadway

FIGURE 27
Aerial view from
the east



27



PASSENGER SEQUENCE OF EVENTS

Airport Access

The entrance ramp to the terminal approaches the building from the north-west, regardless of whether the vehicle was north- or south-bound on the highway. This elevated ramp divides into four separate destinations in a sequential way. The first exit is only for trucks and delivery vehicles which proceed to the underground delivery and storage area. The second exit is on the right and brings the traffic to ground level at which point it splits into two roadways. One goes underground to the parking and the other remains on grade to the west end of the building, serving the main hotel entrance and the bus terminal. The elevated ramp then splits, with the left lanes going down to ground level and the arrivals area, while the right lanes go to the departures level on the third floor.

These last two roadways follow parallel paths on different levels clockwise around the entire building. A circular ramp provides access to parking. After this point the departures and arrivals roadways rejoin and continue to the airport exit and to a recirculation road, which brings traffic back to the entrance.

There are two kinds of parking areas, short- and long-term. The latter are located outdoors and are quite distant from the terminal. The short-term parking is on two levels below the building. The primary entrance is the ramp from the airport entrance, but shortly past the point where the main roadways separate from the building on the south-west corner there is a circular ramp which provides additional access to the underground parking. This ramp is also accessible from the hotel entrance road. This makes it possible to drop-off passengers or hotel guests then park without

FIGURE 28
Diagram showing
sub-division of
entrance ramp

FIGURE 29
Diagram showing
principle vehicular
flow around terminal

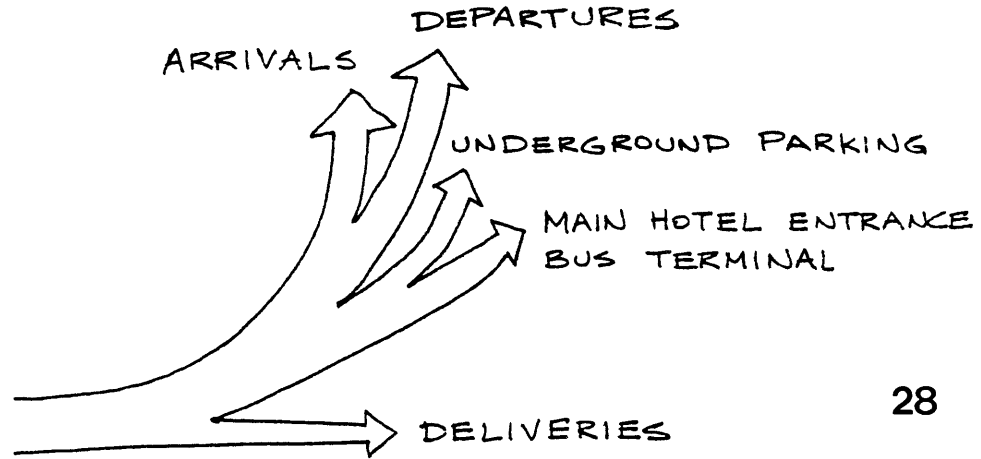

28

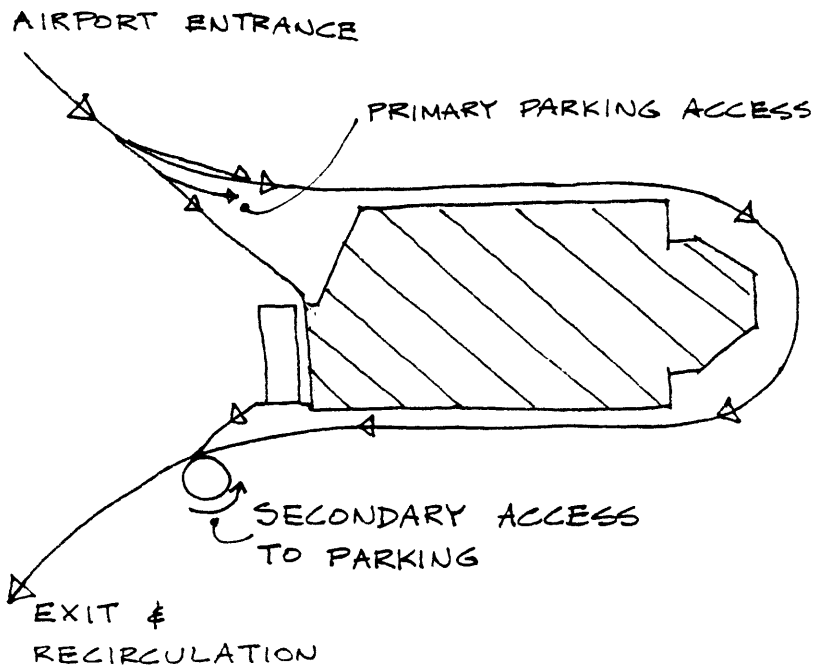

29

without going all the way around to the airport entrance.

The airport is also accessible by bus and train. When arriving with passengers, buses proceed to the departures level, where they stop at at key points. After unloading, they continue all the way around the circulating road and take the ramp down to the bus terminal. There, they are boarded by people leaving the airport. The facility is large enough to hold a number of buses, thus accommodating charters as well as regularly scheduled transportation. Trains arrive at the station two levels below the the west end of the terminal. There are elevators there and escalators which bring people first to the arrivals level, then continue to the upper floors.

Around the corner from the bus terminal is a taxi stand. The majority of taxis serving the airport wait here, although some are available at the north and south exits of the arrivals level.

*FIGURE 30
Plan of west end
of terminal
bus terminal, taxi
stand, and access to
train station*

- 1. Bus loading area*
- 2. Taxi stand*
- 3. Access to trains*
- 4. Access to upper
levels*
- 5. West end of
arcade*
- 6. Cafe/restaurant*

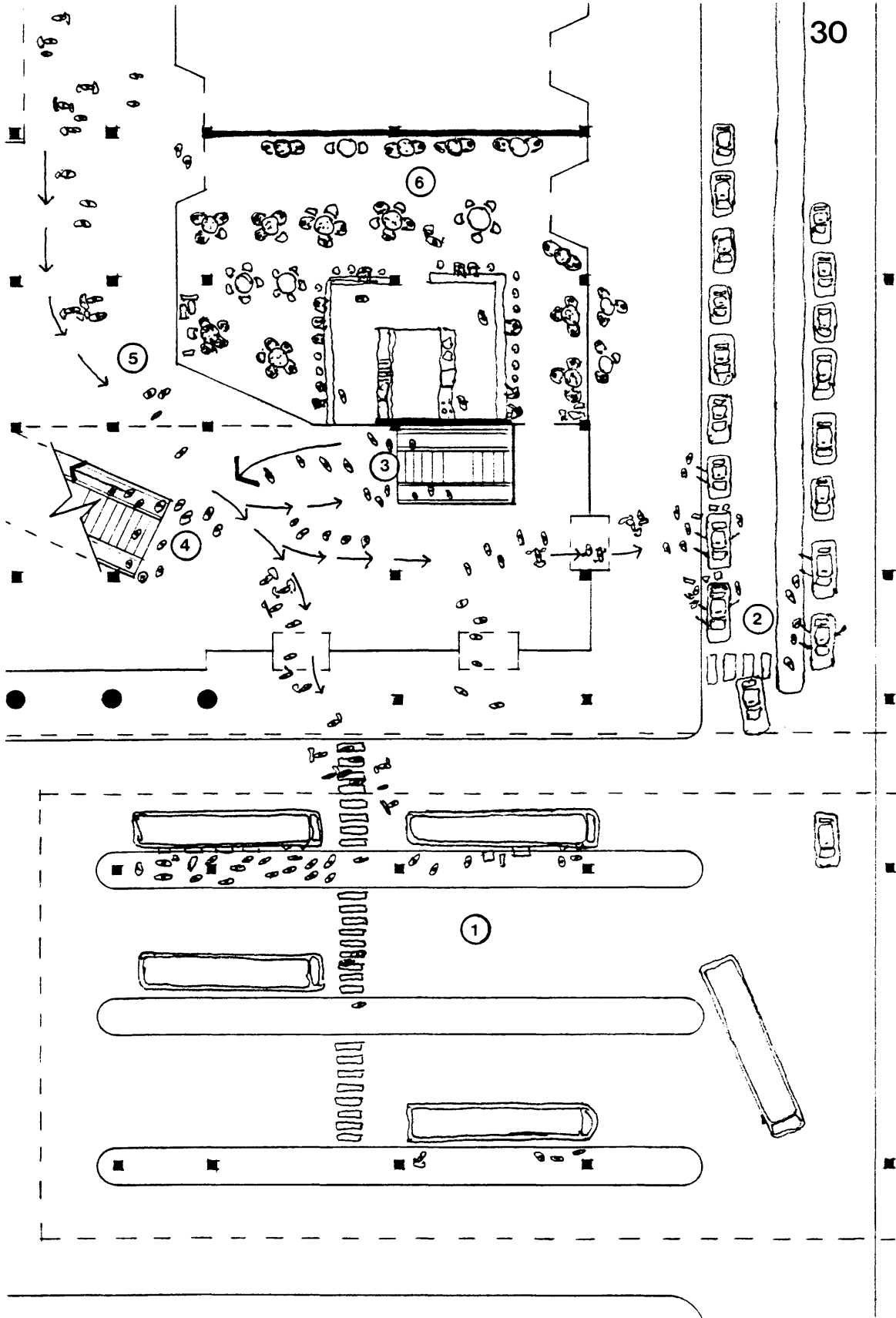

30

Departing Passengers

The enplaning roadway brings departing passengers to the third level, where the ticket and check-in counters are directly accessible. There is also access to this area from the parking levels by elevators. Almost this entire area is covered by a glass space frame. After checking-in passengers may head directly to the departures holding area, or can take a short time to visit shops and restaurants. Both options pass through the central arcade, eventually leading to the escalators and stairs in the waiting area. From this high vantage point, all three satellites are visible.

Once down at the second level, passengers can continue to the appropriate satellite concourse, passing passport control first then security. The 500 foot long concourse has moving walkways to reduce the walking distance to the satellite. Some additional concessions are located in the satellites. The concourse and satellite C is separated into international and domestic areas, the latter not requiring passport control.

FIGURE 31
Plan of ticket lobby
and path to arcade

1. Enplaning passenger access roadway
2. Ticket counters
3. Airline ticket offices
4. Passage to arcade
5. Central dome in arcade
6. Shops

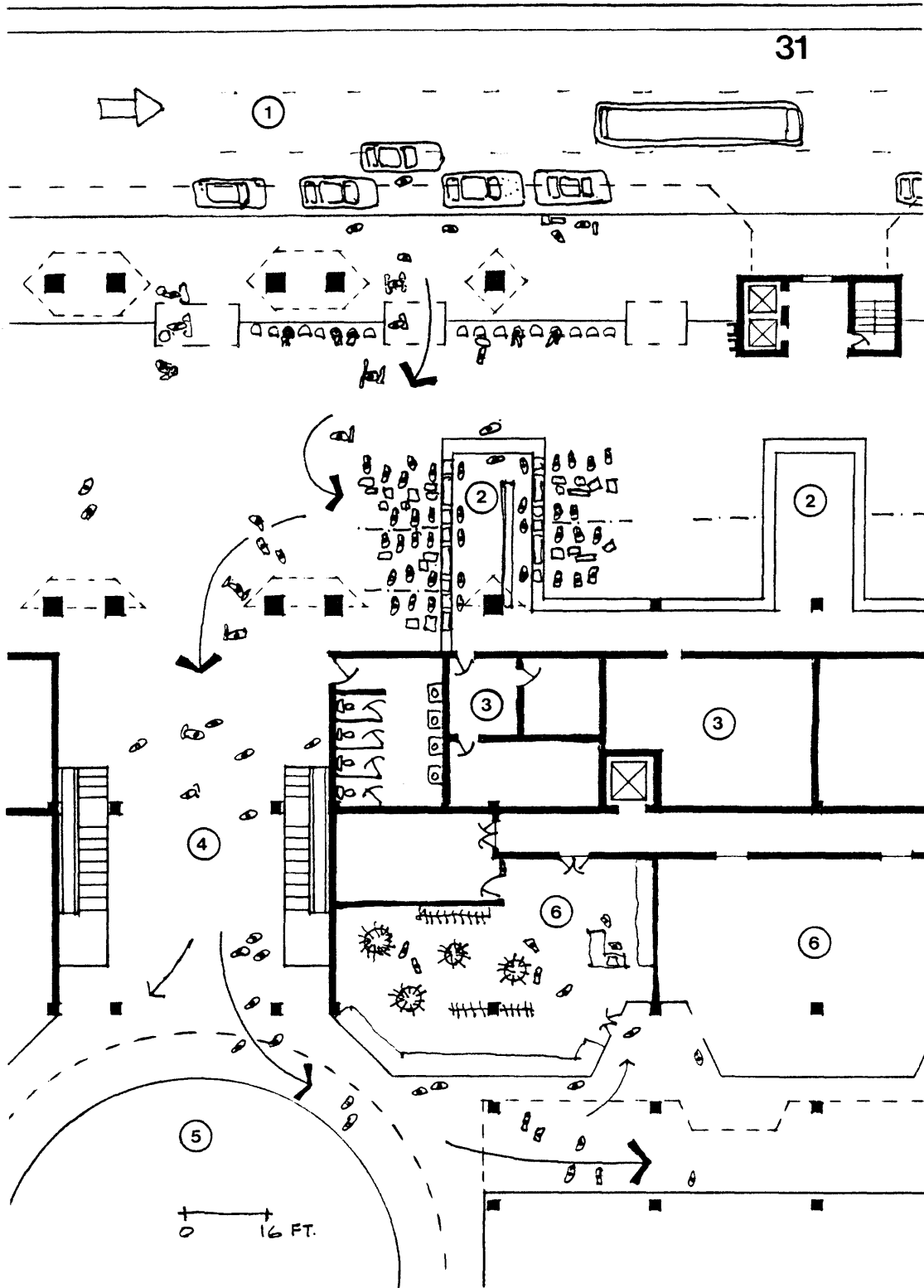

Transfer and Transit Passengers

Transit passengers are those that arrive on a flight wait some time then continue on the same flight. They can wait on the plane or go to the satellite where there are concessions, toilets, telephones and room to stretch their legs. Transfer passengers are those that arrive on one flight then continue on another one. They may have to change satellites but do not have to go through passport control, unless continuing on a domestic flight, or if they want to visit the rest of the terminal. Since passport control is usually a fairly quick operation, it is likely that passengers that have time will take advantage of the terminal facilities.

FIGURE 32
*Plan of concourse
junction to main
holding area*

1. *Departures
holding area*
2. *Passport Control*
3. *Access to
domestic flights*
4. *Concourses to
satellites*
5. *Security*
6. *Access to
arrivals lobby*

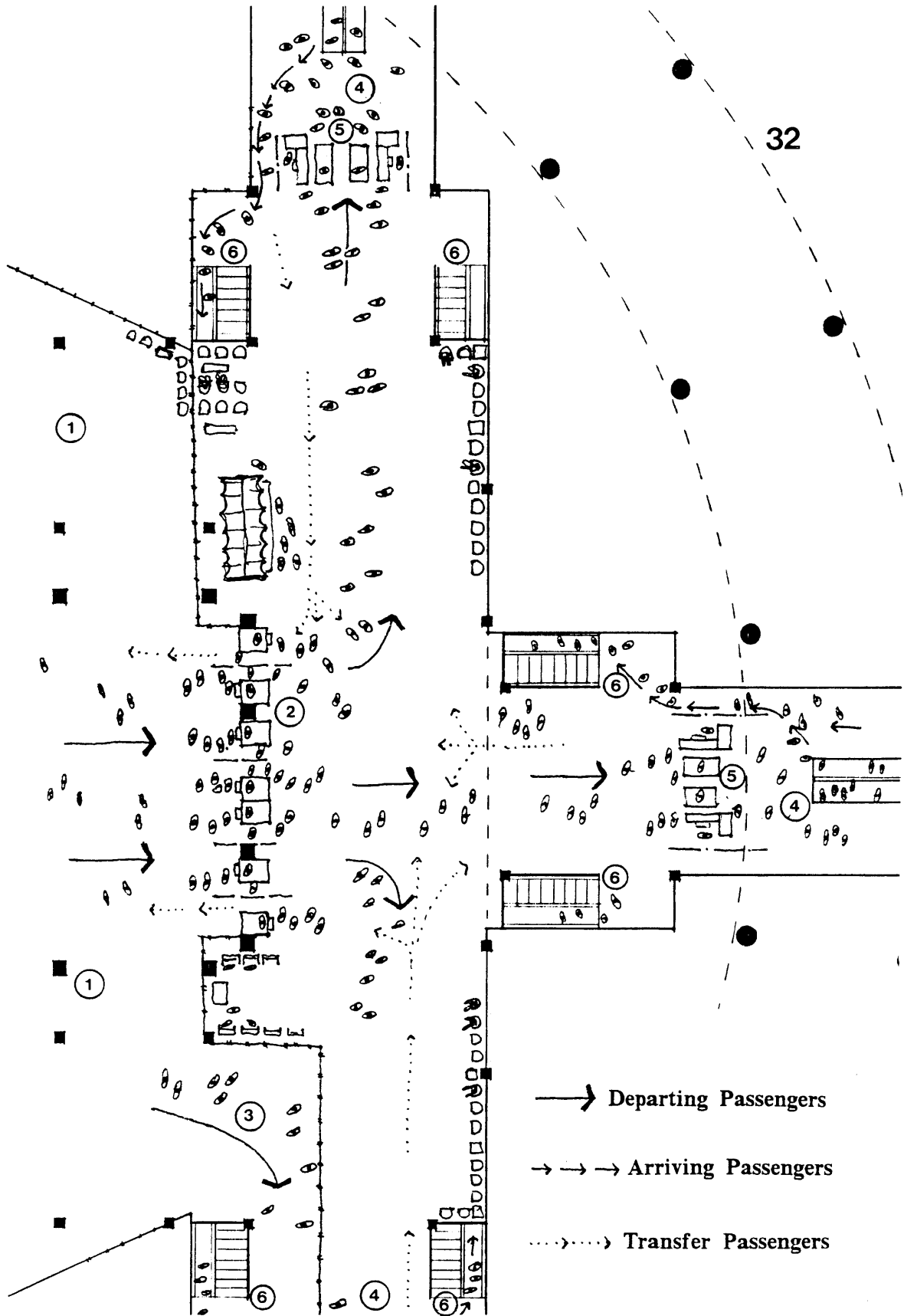

→ Departing Passengers

- - - - - Arriving Passengers

..... Transfer Passengers

Arriving Passengers

After deplaning, arriving passengers proceed through the concourse toward the main building. At the end of the moving walkway, there are escalators and stairs which lead down to the arrivals lobby, where passport control takes place. Then passengers would probably get a cart, and go to the appropriate baggage claim device. After picking up all checked baggage, customs must be cleared.

The doors immediately past the north and south customs counters lead directly to the point where greeters might be waiting, and where car rentals can be arranged. Otherwise, passengers would head west toward the bus terminal, train station, or hotel before leaving the customs area. In addition to the large taxi stand at this location, taxis would also be available at the north and south exits.

FIGURE 33
Partial plan of
arrivals lobby

1. Access from concourses
2. Arrivals lobby
3. Passport control
4. Baggage claim area
5. Baggage carts
6. Lost baggage and information counter
7. offices
8. toilets

FIGURE 34
Partial plan of
baggage claim area

1. Baggage claim devices
2. Customs
3. Greeters area
4. Inspection services offices
5. Car rentals and travel services
6. Offices
7. toilets

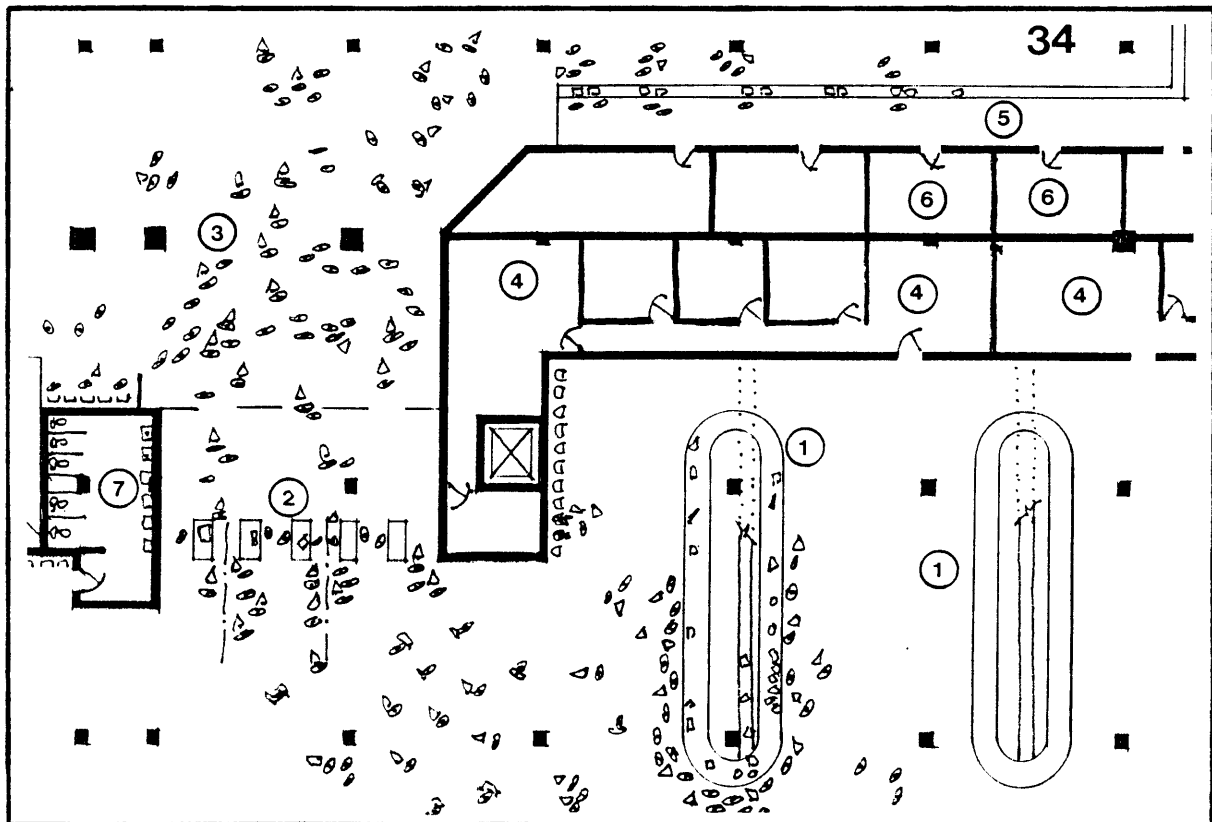
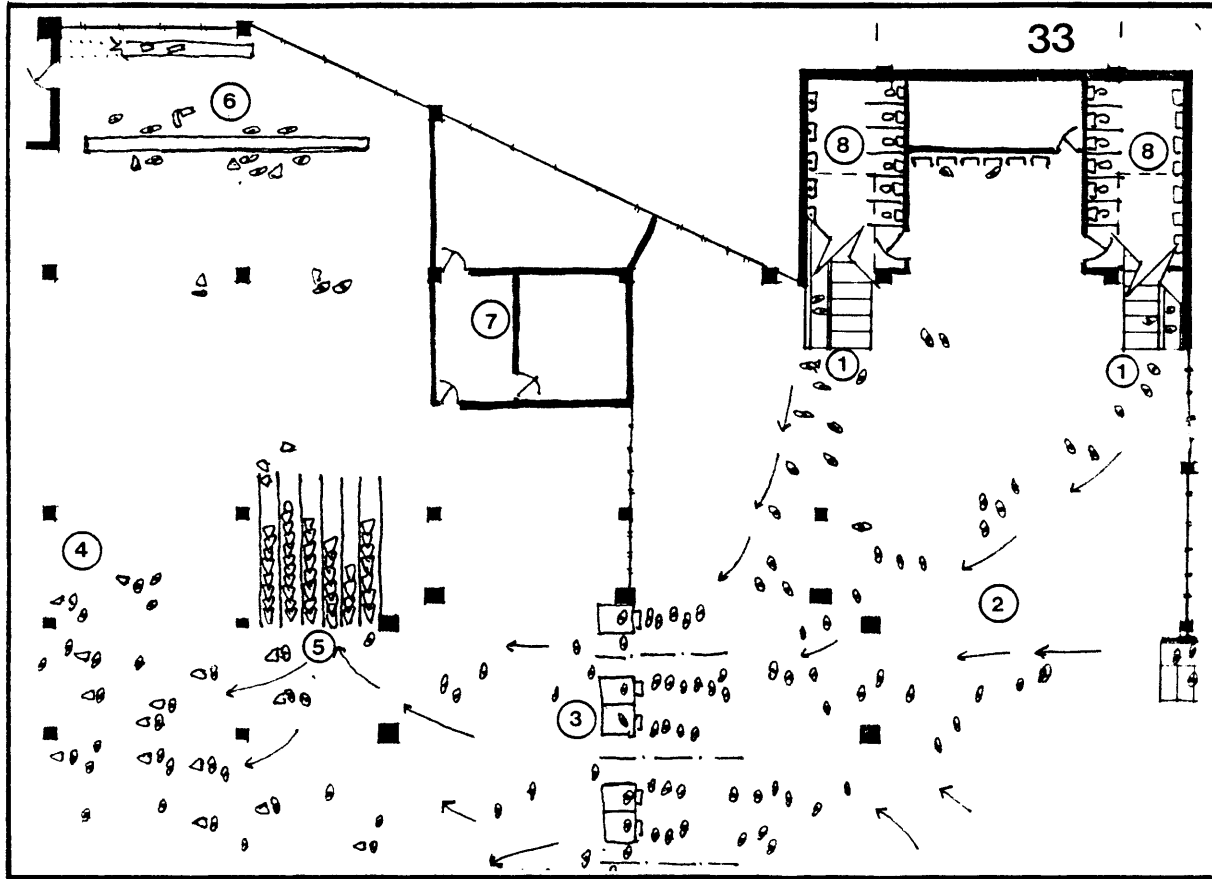

Hotel Access

Although the "main" entrance to the hotel is at ground level and accessible from outside the terminal, it is highly probable the most guests will use the internal entrances often. The street entrance provides access to the public and offers the most formal entry, with a tree-lined fountain court and an awning leading to the major lobby. The secondary entrances, with minor lobbies, are on every floor of the terminal building. The hotel can therefore be reached directly from the arcade at any of the four levels and easily from departures and arrivals access roadways.

Baggage Route

The routing of the baggage relies heavily on the fact that the departures and arrivals levels are separated by an intermediate floor. The facility on this floor accepts bags from the check-in counters above, placing them on a conveyor belt for sorting and loading onto baggage vehicles. These vehicles are then driven down the ramp to the aircraft on the apron area. Incoming bags take the exact reverse procedure to the baggage handling rooms, but are then loaded onto conveyors which carry them down to the baggage claim area. The design is such that steep angles are avoided.

Baggage for transfer passengers is sorted at the satellites, since there is plenty of room below the passenger area on the second floor.

APPENDICES

APPENDIX A: Summary of Program Development

This appendix summarizes the steps taken to develop a preliminary program from which to base a design. The purpose of this program was to give a rough estimate of the areas required to accommodate the expected passenger traffic. The method used also happens to include estimates of areas which are not part of the primary functions. Since the topic of this thesis was the influence these secondary uses on terminal building design their programmatic requirements were greatly increased, along with the inclusion of other secondary functions.

Tables A-1, A-2, and A-3 are the estimates of passenger traffic at Malpensa for the year 1999, based on projections by ItaloAirport. The type of traffic is broken down as follows:

- Alitalia Flights:
 - Domestic
 - International
 - Intercontinental

- All Other Airlines:
 - International
 - Intercontinental

For each category the figures are given for departing as well as arriving passengers. Table A-4 shows only the peak values, which were then used to generate an estimated building program. The Ralph M. Parsons Company, in 1975, wrote a report titled The Apron and Terminal Building Planning Manual for the Federal Aviation Administration, which covers estimates of area requirements for terminals. This reference along with Ashford and Wright's Airport Engineering, which also covers the Parsons method, was used as a model for the calculations. The Preliminary Program Development section which follows reflects the categories used by Ashford and Wright. The principle source of numeric information was tables from Parsons except where a page number from Ashford and Wright is given.

The requirements given here reflect the assumptions inherent in the schematic design by ItaloAirport. Since major reorganization of the functions has been performed many of the numbers no longer apply.

Table A-1: TYPICAL PEAK DAY, MALPENSA 1999: ALITALIA TRAFFIC

HOUR	Domestic Arrivals	Domestic Depart.	Domestic Total	Intern'l Arrivals	Intern'l Departs	Intern'l Total	Intern'l Arrivals	Interc'l Depart.	Interc'l Total	Alitalia Total
0	0	0	0	0	0	0	360	0	360	360
1	0	0	0	0	0	0	0	360	360	360
2	0	0	0	0	0	0	0	0	0	0
3	0	0	0	0	0	0	0	0	0	0
4	0	0	0	0	0	0	0	0	0	0
5	0	0	0	0	0	0	0	0	0	0
6	0	0	0	97	0	97	0	0	0	97
7	148	74	222	661	97	758	0	0	0	980
8	304	185	489	613	758	1371	247	0	247	2107
9	111	267	378	710	807	1517	494	247	741	2636
10	37	74	111	192	419	611	247	494	741	1463
11	74	37	111	388	192	580	630	247	877	1568
12	37	74	111	97	388	485	247	247	494	1090
13	156	37	193	355	97	452	1071	630	1701	2346
14	37	156	193	161	355	516	247	1071	1318	2027
15	37	37	74	161	161	322	0	247	247	643
16	74	37	111	289	289	578	0	0	0	689
17	74	74	148	382	258	640	0	0	0	788
18	148	111	259	289	285	574	0	0	0	833
19	156	111	267	382	386	768	0	0	0	1035
20	37	156	193	0	97	97	75	75	150	440
21	37	37	74	0	188	188	112	0	112	374
22	0	0	0	0	0	0	0	112	112	112
23	0	0	0	0	0	0	0	0	0	0
	1467	1467	2934	4777	4777	9554	3730	3730	7460	19948

Table A-2: TYPICAL PEAK DAY, MALPENSA 1999: OTHER PASSENGER TRAFFIC

HOUR	Intern'l Arrivals	Inern'l Depart.	Intern'l Total	Interc'l Arrivals	Interc'l depart.	Interc'l Total	Total Arrivals	Total Depart.	Total General
0	0	0	0	0	0	0	0	0	0
1	0	0	0	0	0	0	0	0	0
2	0	0	0	0	0	0	0	0	0
3	0	0	0	0	0	0	0	0	0
4	0	0	0	0	0	0	0	0	0
5	188	0	188	0	0	0	188	0	188
6	0	0	0	0	0	0	0	0	0
7	417	316	733	0	0	0	417	316	733
8	671	353	1024	217	0	217	888	353	1241
9	575	607	1182	217	0	217	792	607	1399
10	850	736	1586	383	217	600	1233	953	2186
11	988	753	1741	0	217	217	988	970	1958
12	514	1085	1599	217	0	217	731	1085	1816
13	515	578	1093	577	600	1177	1092	1178	2270
14	656	432	1088	0	577	577	656	1009	1665
15	289	578	867	217	0	217	506	578	1084
16	650	495	1145	0	217	217	650	712	1362
17	353	477	830	0	0	0	353	477	830
18	463	256	719	0	0	0	463	256	719
19	593	605	1198	0	0	0	593	605	1198
20	64	451	515	0	0	0	64	451	515
21	64	128	192	0	0	0	64	128	192
22	128	0	128	217	0	217	345	0	345
23	0	128	128	0	217	217	0	345	345
	7978	7978	15956	2045	2045	4090	10023	10023	20046

Table A-3: TYPICAL PEAK DAY, MALPENSA 1999: TOTAL PASSENGER TRAFFIC

HOUR	Domestic Arrivals	Domestic Depart.	Intern'l Arrivals	Intern'l Depart.	Interc'l Arrivals	Interc'l Depart.	Total Arrivals	Total Depart.	Total General
0	0	0	0	0	360	0	360	0	360
1	0	0	0	0	0	360	0	360	360
2	0	0	0	0	0	0	0	0	0
3	0	0	0	0	0	0	0	0	0
4	0	0	0	0	0	0	0	0	0
5	0	0	188	0	0	0	188	0	188
6	0	0	97	0	0	0	97	0	97
7	148	74	1078	413	0	0	1226	487	1713
8	304	185	1284	1111	464	0	2052	1296	3348
9	111	267	1285	1414	711	247	2107	1928	4035
10	37	74	1042	1155	630	711	1709	1940	3649
11	74	37	1376	945	630	464	2080	1446	3525
12	37	74	611	1473	464	247	1112	1794	2906
13	156	37	870	675	1648	1230	2674	1942	4616
14	37	156	817	787	247	1648	1101	2591	3692
15	37	37	450	739	217	247	704	1023	1727
16	74	37	939	784	0	217	1013	1038	2051
17	74	74	735	735	0	0	809	809	1618
18	148	111	752	541	0	0	900	652	1552
19	156	111	975	991	0	0	1131	1102	2233
20	37	156	64	548	75	75	176	779	955
21	37	37	64	316	112	0	213	353	566
22	0	0	128	0	217	112	345	112	457
23	0	0	0	128	0	217	0	345	345
	1467	1467	12755	12755	5775	5775	19997	19997	39994

Table A-4: PEAK VALUES of Passenger Traffic

DEPARTURES	PASSENGERS	TIME
Alitalia		
International	808	9
Domestic	267	9
Total	1582	14
Other Airlines		
International	1085	12
Intercontinental	1178	13
All intercontinental	1648	14
ARRIVALS	PASSENGERS	TIME
Alitalia		
International	710	9
Domestic	304	8
International + intercontinental	1426	13
Other Airlines		
International	988	11
Intercontinental	1092	13
All intercontinental	1648	13

PRELIMINARY PROGRAM DEVELOPMENT

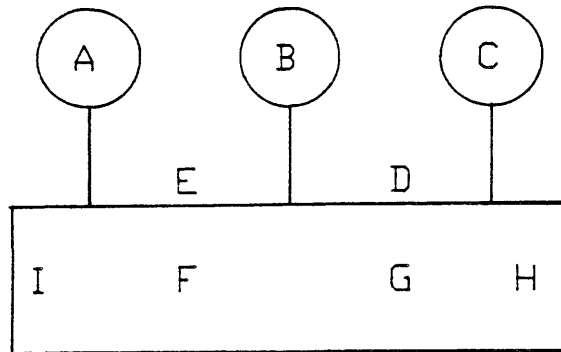

Preliminary schematic showing key to locations.

- A. Satellite:
9 gates, all airlines except Alitalia, for international flights.
- B. Satellite:
7 gates: 4 for 747's and 3 for DC-10 class aircraft.
all airlines including Alitalia, for intercontinental flights.
- C. Satellite:
9 gates, Alitalia international flight only.
- D. 1 gate for DC-9 class aircraft,
and 4 parking areas for ATR-42 aircraft to accessed by foot.
Alitalia domestic flights.
- E. 2 gates for DC-9 class aircraft, to be used for international commuter
service by airlines other than Alitalia.
- F. Airline ticket offices (ATO), lobby, baggage claim, etc. for airlines
other than Alitalia.
- G. ATO, lobby, baggage claim, etc. for Alitalia.
- H and I. Departure lounges, lobbies, waiting areas, and baggage claim for
remote aircraft location servicing charter flights and eastern
European flights.

PRELIMINARY PROGRAM CALCULATIONS

<u>Item Description</u>	<u>Location</u>	<u>Area (sq. ft.)</u>	<u>Source</u>
Airline Ticket Counters			4-5
Other airlines	F	2,200 (220 ft. long)	
Alitalia	G	2,800 (280 ft. long)	
Charters and Eastern Flights	H + I	1,400 (140 ft. long)	
Airline Ticket Offices and Support Space		4-6	
Other airlines	F	2,400	
Alitalia	G	3,100	
Charters and Eastern Flights	H + I	1,500	
Outbound Baggage Room			4-15, 4-16
Other Airlines	F	7,500	
Alitalia	G	10,500	
Charters and Eastern Flights	H + I	4,000	
Baggage Claim and Customs			
Other Airlines	F	43,600 (450 ft. device length)	4-31
Alitalia, international and intercontinental	G	56,800 (600 ft. device length)	4-31
Alitalia, domestic	G	4,300 (80 ft. device length)	4-21,23,24
Charters and Eastern Flights	H + I	25,500 (300 ft. device length)	4-31
Airline Operations and Support		4-6	
Other Airlines	F	13,000	
Alitalia	G	14,200	
Eastern European flights	H or I	3,400	
Departure Lounges			p.243, A+W
Other Airlines, international	A	24,300	
All intercontinental	B	23,700	
Alitalia international	C	24,300	
Alitalia domestic	D	3,700	
Other Airlines additional international	E	2,200	
Charter flights	H	13,500	
Eastern European Carriers	I	13,500	
Other Airline Space			p.244, A+W
Other Airlines	F	650	
Alitalia	G	710	
Eastern European Carriers	H or I	170	

<u>Item Description</u>	<u>Location</u>	<u>Area (sq. ft.)</u>	<u>Source</u>
Sub-totals			
Other Airlines		107,700	
Alitalia		132,300	
Eastern European Carriers		63,200	
SUB-TOTAL for all airlines		303,200	
Lobby and ticketing			4-7
Other Airlines	F	5,000	
Alitalia	G	6,000	
Charters and Eastern European	H + I	4,000	
Lobby waiting area fot departure		4-8	
Other Airlines	F	4,700	
Alitalia	G	5,700	
Charters and Eastern European	H + I	7,100	
Lobby for baggage claim			p.245, A+W
Other Airlines		included in (4)	
Alitalia, international and intercontinental		included in (4)	
Alitalia domestic	G	8,100	
Charters and Eastern European		included in (4)	
Food and Beverage		5,600	4-25
Other concessions and services	6,700	4-26	
Other rental areas		3,400	p.246, A+W
Other circulation space		212,200	p246, A+W
SUB-TOTAL		571,700	
HAVC and other mechanical		85,800	p246,A+W
SUB-TOTAL		657,500	
Structure		32,900	p.246,A+W
<hr/>			
TOTAL ESTIMATED AREA		690,000	

APPENDIX B: Airport terminal types

There are three generally recognized categories for terminal buildings (DeNeufville), they are:

1. Centralized, with either (a) finger piers or (b) satellite subterminals linking passengers and aircraft;
2. Linear or 'gate arrival', in which aircraft are parked close to the ground access;
3. Open-apron or 'transporter', using buses or special vehicles to carry passengers between the terminal and the aircraft.

In addition to these 'pure' concepts there are many examples of hybrids incorporating more than one type. The selection of type is usually based on planning studies which take into account among other things the aircraft types, passenger mix, ground access, and the expected growth.

A brief explanation along with a flow diagram, showing the sequence of events for each type follows.

Pier Types of Terminals

The pier configuration began in the 1950's as a way separating the waiting areas for each flight, and placing them next the departure gate. Eventually, the additional advantages of separating the gates from the main terminal building were also realized. The building could remain quite small, better suited to accomodate people, while the piers could stretch out far enough to provide adequate room for the aircraft. This system can pose many problems, however. Walking distances down the pier can be rather long, and providing a moving walkway may be impossible since gates are positioned along the entire length of the pier. One popular solution is to use more than one pier, but this too can cause problems. The length of the main building may then depend on the distance required between the piers and there can be aircraft congestion on the apron. Transfer passengers, especially those that must proceed to a gate in another pier, probably tend to suffer most due to the long distances.

Expanding such an airport can be a problem if it has not been taken into account originally. If there is room to lengthen a pier, this could be done, but it may result in congestion in the main building or at the curbside. Another approach is to add piers, but unless specifically planned for, there is rarely enough room. None the less, because this type of terminal usually requires less total space and because functions are more concentrated in the main building, it can often be cost effective.

Examples of pier type:
Amsterdam, Schiphol
Chicago, O'Hare
London, Heathrow

FIGURE 35
Pier concept
source: Blankenship

FIGURE 36
Pier concept
Functional diagram
source: Blankenship

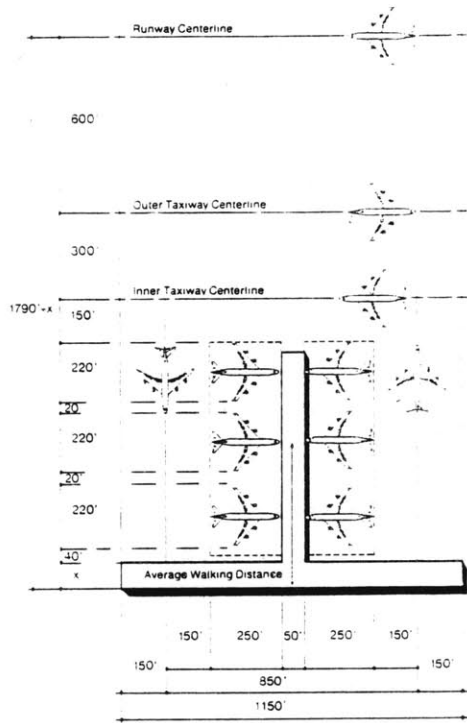

35

36

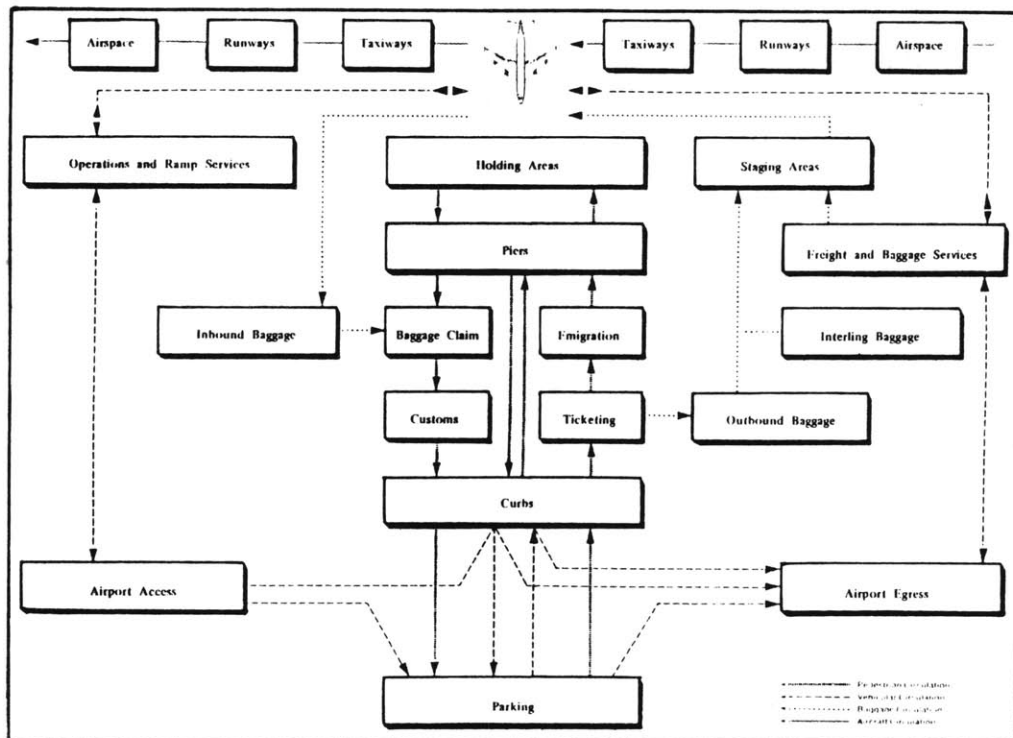

The Satellite concept for terminals

Satellite schemes were originally introduced to improve aircraft movement by placing the connection to the main building underground. Other advantages of this type, which almost always have people moving equipment to transport passengers to and from the satellites, include short walking distances and concentration of activities not only in the main building but in each satellite. This means that more shared facilities can be provided, requiring a smaller total area, and perhaps making economically feasible to provide concessions and other services close to the waiting areas. As with piers but to a lesser extent, a satellite system can make it difficult for transfer passengers.

Expandability is even more difficult than with pier concepts, since it is usually impossible to simply increase the size of a satellite (especially if it is circular, octagonal, hexagonal..). The only option left is the construction of an additional satellite, and then there must be a need for more than just one or two gates. This can also result in congestion in the main building or curbside.

Examples of satellite configuration:

- Seattle-Tacoma International Airport
- Tampa International
- JFK, TWA Terminal.

FIGURE 37
Satellite concept
source: Blankenship

FIGURE 38
Satellite concept
Functional diagram
source: Blankenship

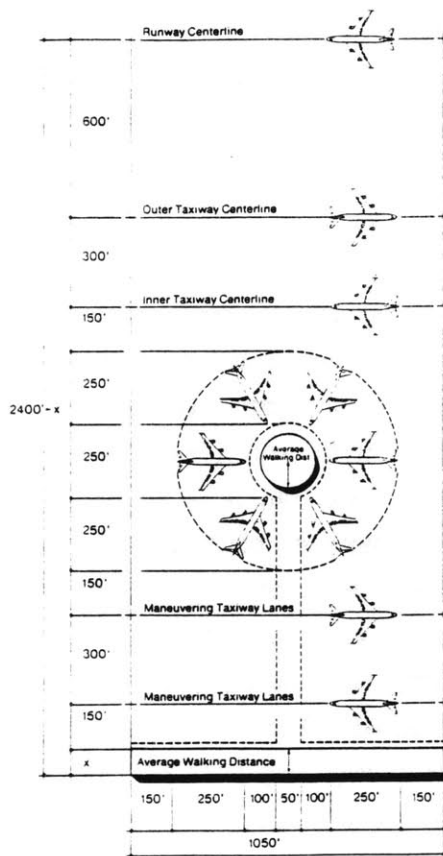

37

38

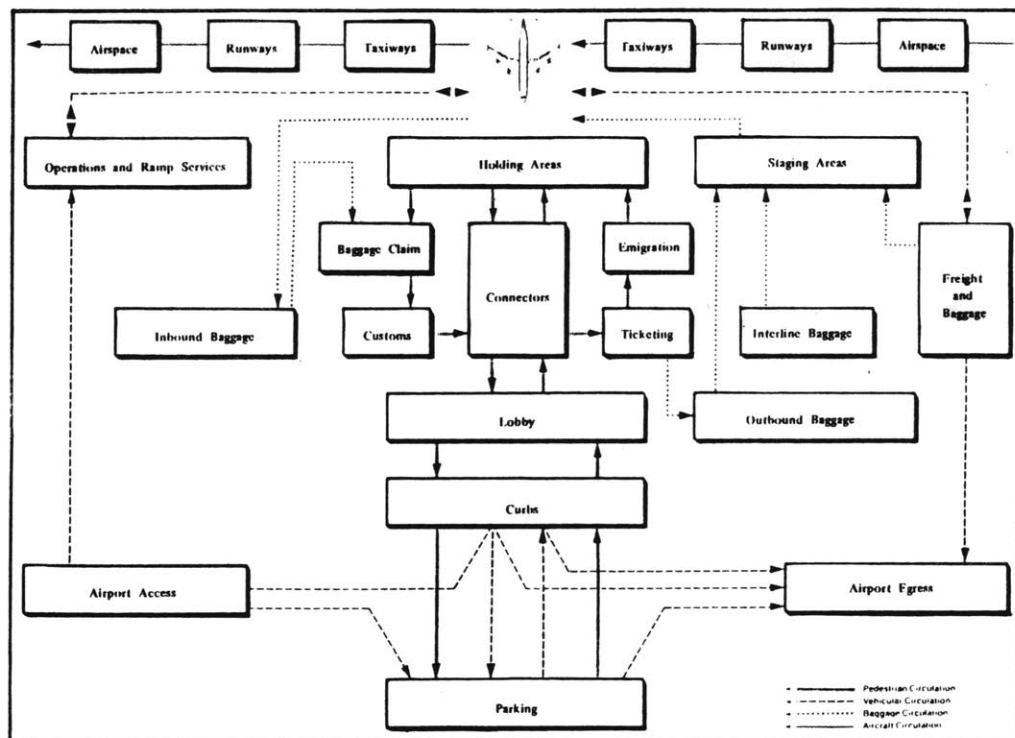

95

The Linear concept

The linear configuration is one where there is a direct relationship between each gate and the curbside. In this scheme, the distance between automobile and aircraft is minimized. The gates are simply positioned as close together as possible given aircraft requirements and the remaining functions for enplaning and deplaning are stretched out to approximately the same distance. The shape of the building can be bent in such a way as to reduce the length of the landside, but it is still an inherent problem. Another major problem is the duplication of almost all functions for each gate or small set of gates. For a linear type to work properly, there must be appropriate security (and customs) entrances and exits located at regular intervals. The transfer passenger will almost certainly have a very long walk or require some sort of other transportation such as a bus to get the next gate.

Linear types, however, lend themselves to easy expansion since the terminal can be made almost any length. Or if the buildings are bent, they can be repeated as required. Because of their simple design, construction costs can be very low, operating costs, however, are probably rather high.

Examples of linear concept:

Kansas City.

Dallas/Fort Worth.

FIGURE 39
Linear concept
source: Blankenship

FIGURE 40
Linear concept
Functional diagram
source: Blankenship

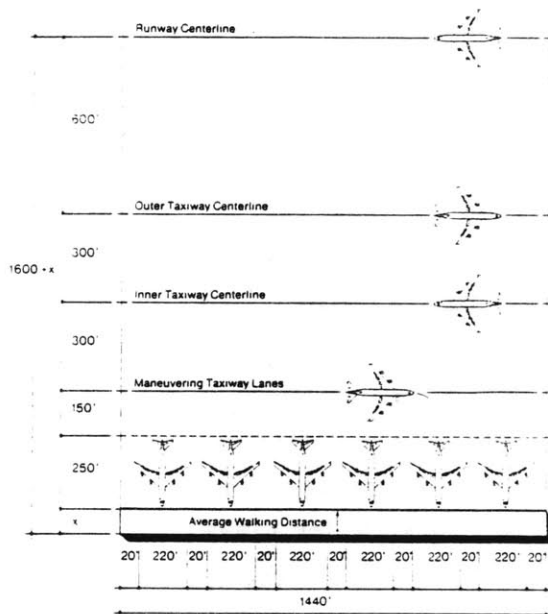

39

40

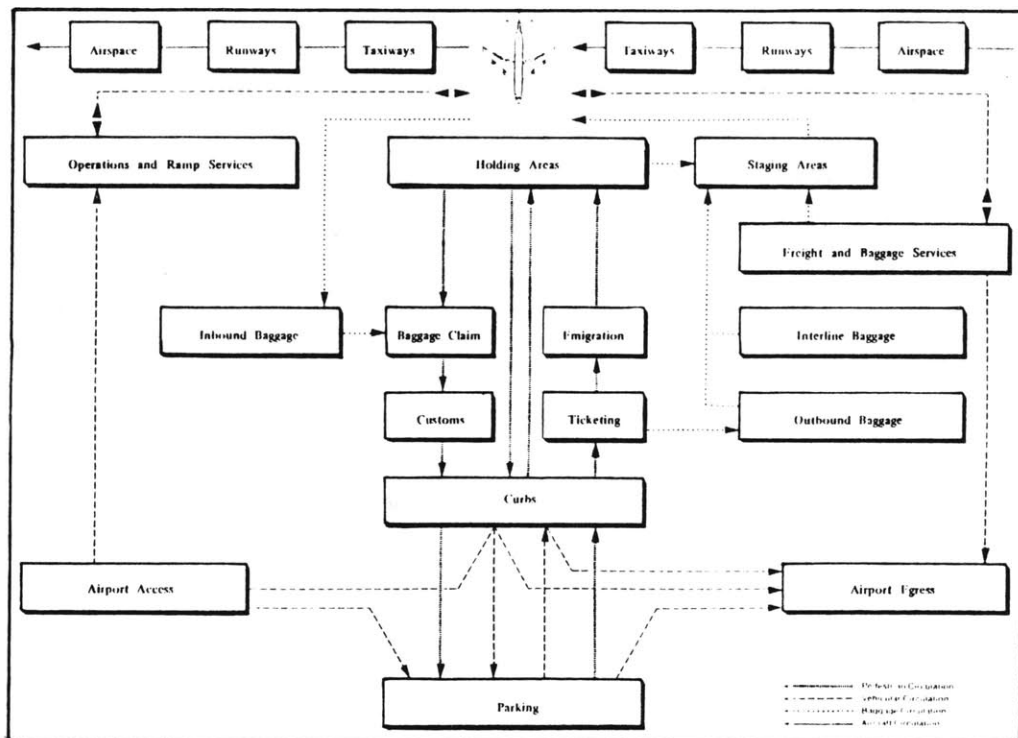

The Remote (Transporter) Type

The remote or transporter type of terminal building is almost non-existent in its pure form. The operational and maintenance costs of using mobile lounges to reach all the aircraft and the extra time involved in boarding them are usually too high to balance the benefits. Most of these systems are used at other types of airports to handle the peak traffic periods.

The main advantage is that this type offers extreme flexibility in coping with immediate, seasonal, as well as longer term changes. No special permanent provisions have to be taken to allow for future developments in the design of aircraft. Peak conditions can be better handled, by simply increasing the number of transporters used to serve each aircraft. And the terminal building itself can be rather small since it does not have to accommodate any or all of the aircraft. These result in a much smaller initial investment, but a considerably higher operational cost than other systems, but changes in demand, large or small, can be easily accommodated.

For all passengers, including transfers, the connection time from terminal to aircraft is longer, but the walking distances are greatly reduced. Finally, since the waiting areas are in the main building, more services and concessions can be provided, in a more concentrated place.

Examples of 'pure' transporter systems:

Washington, Dulles International
Montreal, Mirabel International

FIGURE 41
Remote concept
source: Blankenship

FIGURE 42
Remote concept
Functional diagram
source: Blankenship

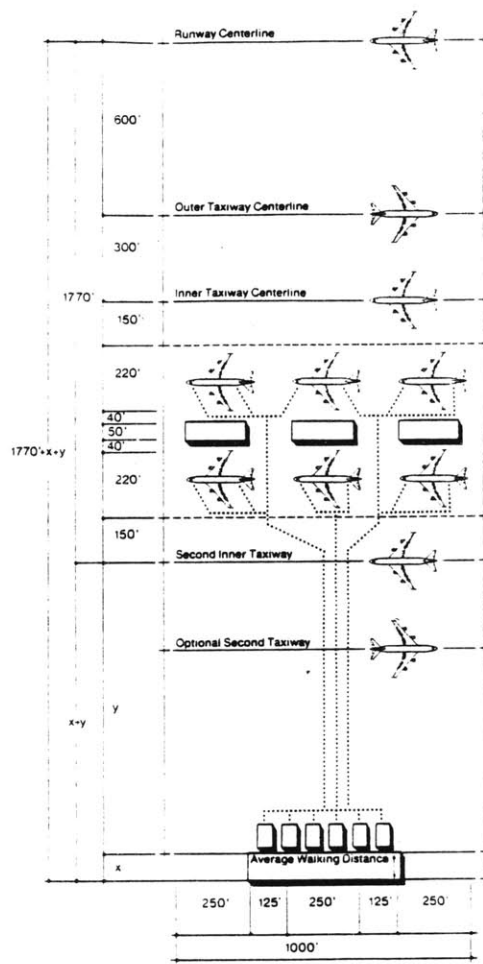

41

42

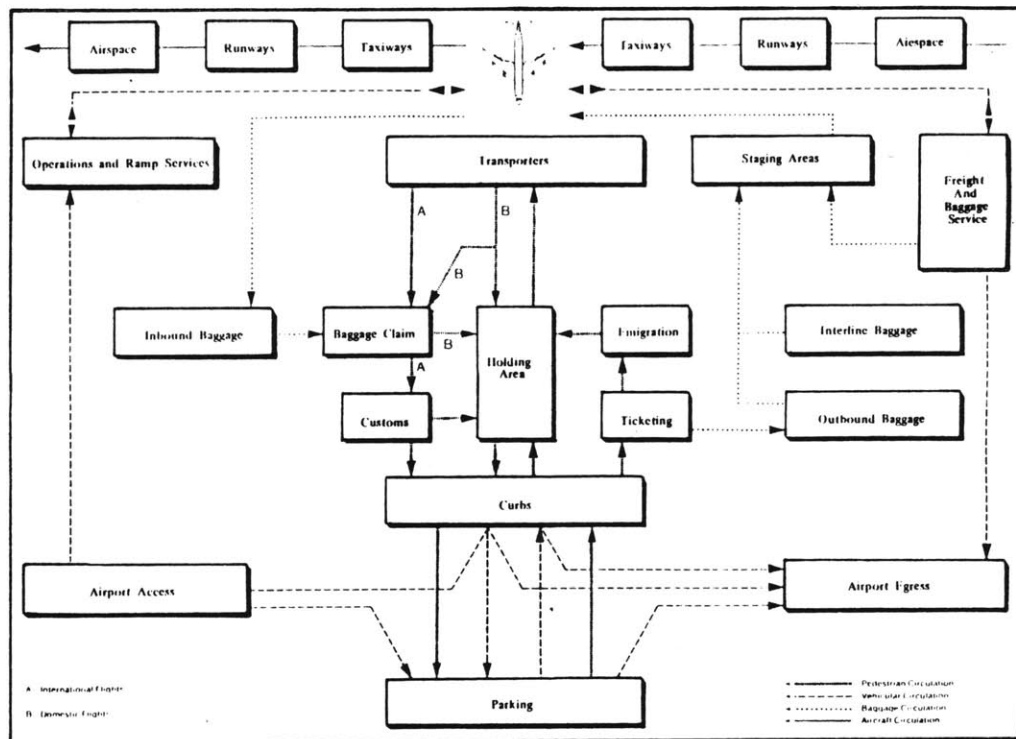

Appendix C: BIBLIOGRAPHY

- Allen, Roy. Great Airports of the World. Ian Allen Ltd., London, 1968.
- Allen, Roy. Major Airports of the World. Charles Scribner's Sons, New York, 1979.
- Allen, Roy. Major Airports of the World. Ian Allen Ltd., London, 1983.
- Ashford, Norman and Wright, Paul. Airport Engineering. John Wiley and Sons, 1979.
- Blankenship, Edward G. The Airport: Architecture - Urban Integration - Ecological Problems. Praeger Publishers, New York, 1974.
- Barr, Vilma and Broudy, Charles. Designing to Sell. McGraw Hill Book Co., New York, 1986.
- Brillembourg, Marie-Claire. Transfer Passenger Needs at Airports - Human Factors in Terminal Design. S.M.Arch.S. Thesis, M.I.T., 1982.
- De Neufville, Richard. Airport Systems Planning: A Critical look at the Methods and Experience. The M.I.T. Press, 1976.
- Funk, Susan K. A Terminal for Atlanta's Hartsfield international Airport. S.M.A.A and M.Arch.A.S. Thesis, M.I.T., 1979.
- Geist, Johann Friedrich. Arcades: The History of Building Type. The MIT Press, Cambridge, Massachusetts. 1983.
- Horronejff, Robert. Planning and Design of Airports. 1983.
- Lawson, Fred. Conferences, Conventions, and Exhibition Facilities. The Architectural Press, London, 1981.
- Mills, Marvin. "The Human Dimension in Airport Design". Architectural Record, Nov. 1974.
- Naar, Jon, and Russell, Beverly. "Peaceful Inspiration". Interiors, Mar. 1984.
- Ralph M. Parsons Co. The Apron and Terminal Building Planning Report. 1975.
- Ruconi-Clerici, Ignazio. Aren't Airport PLnners Forgetting About Transfers? S.M.C.E. Thesis, M.I.T., 1976.
- Woolley, David. "Airports and Their Equipment". Interavia, Sept. 1985.

OCT 21 1986

0780 AC