

BUILDING ON STEEP SLOPES:
An Exploration and Presentation of Building Strategies

by

William Fenn Roslansky
Bachelor of Science in Mechanical Engineering
Massachusetts Institute of Technology
Cambridge, Massachusetts, 1982

Submitted to the Department of Architecture in partial fulfillment of
the requirements of the degree Master of Architecture at the

MASSACHUSETTS INSTITUTE OF TECHNOLOGY
February, 1986

© William Fenn Roslansky 1986

The author hereby grants to M.I.T. permission to reproduce and to
distribute publicly copies of this thesis document in whole or in part

Signature of the author _____

William Fenn Roslansky, Dept. of Architecture
January 17, 1986

Certified by _____

Jan Wampler, Professor of Architecture
Thesis Supervisor

Accepted by _____

MASSACHUSETTS INSTITUTE
OF TECHNOLOGY

Julie Moir Messervy, Chairman
Departmental Committee for Graduate Students

Rotch

MAR 06 1986

BUILDING ON STEEP SLOPES:
An Exploration and Presentation of Building Strategies

by

William Fenn Roslansky

Submitted to the Department of Architecture on January 17, 1986 in
partial fulfillment of the requirements for the
Degree of Master of Architecture.

ABSTRACT

This thesis is an overview of the aspects of building on steeply sloped land. Problems of building, techniques for building, and the criteria for liveability are explored. Simplified, the underlying premise is that changing our environment in a positive way requires an understanding of what is to be changed, and what is to be added.

Building methods are enumerated, described, and their behaviour is explored on a range of slopes from 20° to 50°. From this study design break points and recommendations for use are determined. Issues particular to steep slope development such as geological impact and landscape preservation are examined as criterion for evaluating solutions. When slope angles exceed 20°, it becomes more sensible to disassociate structures from the ground. The consequences of cutting into a hillside v.s. disassociating the structure from the hillside are discussed.

Building on hillsides is a multidisciplinary problem. The thesis attempts to create a dialogue between engineering problems and architectural issues in order to understand when they do or don't reinforce each other.

Thesis Supervisor: Jan Wampler
Title: Professor of Architecture

ACKNOWLEDGMENTS

Many thanks to Jan Wampler who provided consistant, thoughtful advice throughout the process,

and to my fellow students in room 10-485; Sally, Victor, Jim, Cathy, Susan, Ariel, and Margaret, who helped make thesis "fun".

I would also like to remember Chris Hassig, who should have been here with us.

I deeply appreciate the time Michael Spexarth, Waclaw Zalewski, Ralph Thut, and Gary Hack spent in providing criticism and advice.

Warm thanks to my mother for editing the first rough draft.

TABLE OF CONTENTS

INTRODUCTION.....	7	Hybrids.....	85
Motivation.....	9	Cantilevers.....	87
Parameters And Method Of Study.....	10	BUILT EXAMPLES.....	89
STEEP SLOPE ISSUES.....	13	HOUSING ISSUES.....	95
Landscape Preservation.....	13	Light and Views.....	95
Density and Slope Steepness.....	17	Parking.....	109
Geology.....	21	Automobile Access.....	115
Water and Erosion Control.....	22	Pedestrian Access.....	121
BUILDING SYSTEMS.....	25	Community Space.....	129
Balanced Cut And Fill.....	31	Private Space.....	131
Cut And Fill With Retaining Walls.....	39	CONCLUSIONS.....	137
Stepped Sections.....	45	APPENDICES.....	141
Cut And Buttress.....	55	Foundation Types.....	141
Fill.....	63	Housing Types.....	149
Pier And Grade Beam.....	67	BIBLIOGRAPHY.....	157
Pole Structures.....	73		

INTRODUCTION

The intent of this thesis is to examine and present some of the available methods for building on steeply sloping land. The two major areas of interest are 1. What systems are available/appropriate for building given various angles of slope?, and 2. What are their characteristics and potentials?

By understanding some of the geologic and engineering problems involved, and the nature of the systems which form the solutions, a designer can take better advantage of the available technology. The engineering issues are concentrated under Building Systems, and address the how to and when can it be done questions. The architectural issues presented temper the building methods by applying issues of

liveability. Criteria for liveability are presented under Housing Issues. The intent is not to eliminate professionals by combining areas of expertise, but rather to catalyse a dialogue which will improve judgement and capability for developing difficult or sensitive sites.

The cost of building on a hill is high, so the maximum should be gotten out of the major moves. The thesis is concerned with establishing design break points, so that it can be useful as a decision making guide. Hopefully such a catalogue will enable designers to grapple more easily with some of the issues involved, and allow them to use the hillsides in a manner more sensitive to the nature of these lands.

The issue of landscape preservation

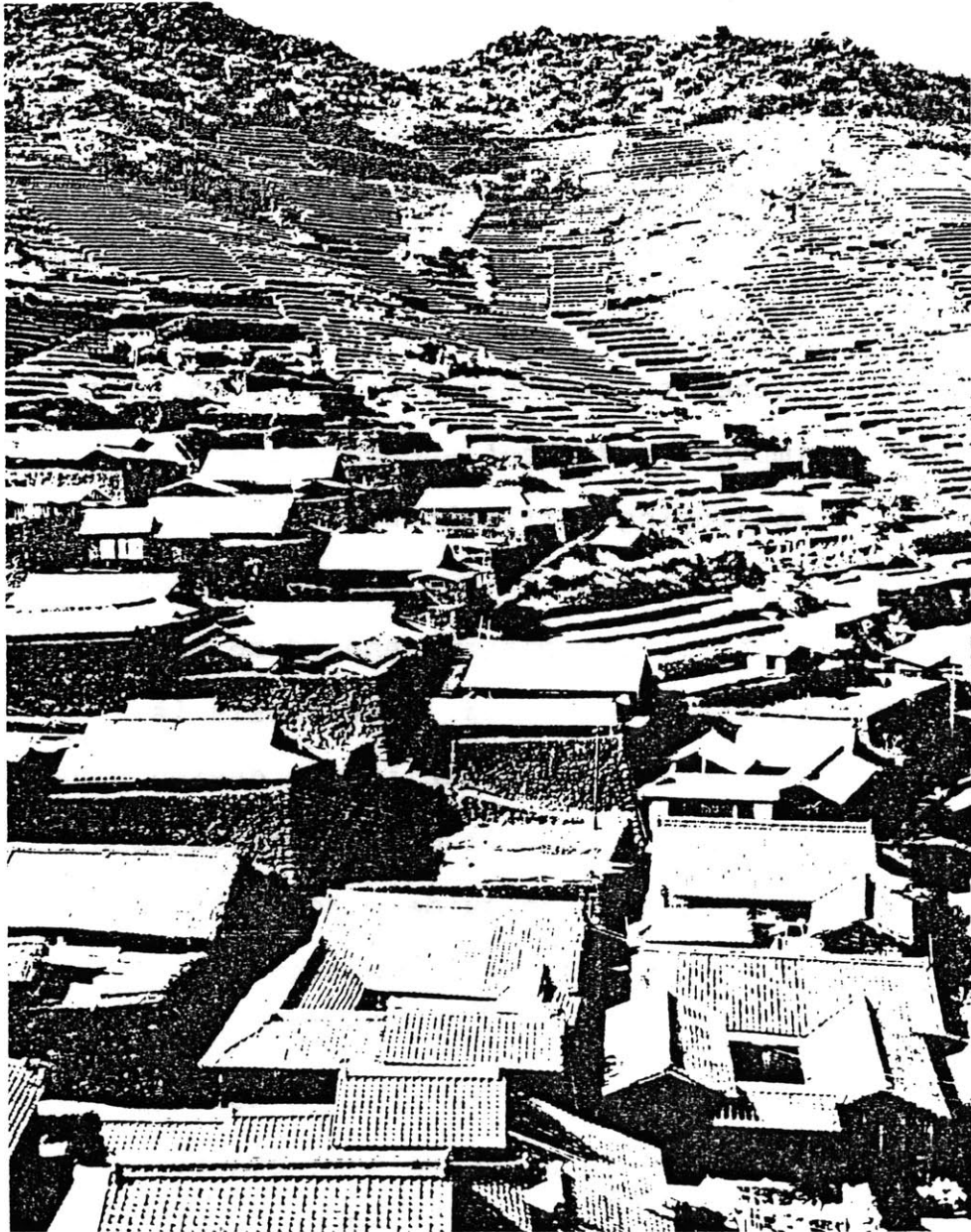

Figure 1. Houses on terracing land in Sotadamaru, Japan

is of particular interest. The repose of the topsoil on steeper hillsides is a fragile thing, to be treated with care. Can steep slopes be built on in a way which protects and enhances the landscape? It is certain that hills can be transformed into collections of flat areas without destroying the sense of landscape. One reference for this is terracing in Sotadama, Japan. Figure 1. What happens as the slope gets steeper? When should a hillside be built, or not built upon, and why? The vehicle for answering these and other questions, is found in trying to determine how to build on the hillsides.

MOTIVATION

In today's building climate, easily developed flat land is becoming a rarity. As the supply of land which is easy to build on decreases, difficult sites such as hillsides and wetlands become economically more viable due to rising land costs. Building on the hillsides also helps preserve the flat lands which are valuable agricultural resources. If these sensitive types of land are to be used, municipalities must adopt zoning rules, and Architects must think about how to best use specific sites. Putting the foundation in the ground the conventional way, starting with excavating footing trenches, can wreak great havoc on a piece of a steep land, scarring sites permanently, thus thwarting the good

intentions of the designer.

The ultimate goal is to use the land without destroying the landscape. Homeowners are willing to pay top dollar to build on view lots. The impact of such development on the very view these hilldwellers seek must be assessed.

Apart from the current demand for buildable land, people have sought to live on hillsides since the beginning of time. Cavemen found caves, feudal lords built defensible strongholds, and today people seek hills for the panoramic views and the sense of space. Perhaps this has something to do with the thrill of looking down a mountainside, or preferring a balcony seat at the theatre. Hillside houses range from half story changes in level to dizzying overhangs, and may be no place for an acrophobe!

PARAMETERS AND METHOD OF STUDY □

Available foundation types were identified as the basis for establishing the building systems which are likely to be used on slopes. The behaviour of these building systems was then examined on a range of slopes from about 20° to 50° . A set of issues relevant to housing or building on slopes were identified and used to evaluate the performance of the building systems on the various slope angles. These issues are dealt with only in so far as they are applicable to building housing on steep slopes, and thus are not exhaustively examined. The slopes are classified by inclination as shown in figure 2.

The program for the thesis is medium density housing, around 20 - 30 d.u./acre

(dwelling units/acre), with a parking space per unit ratio of 2.0. To help limit the scope of the thesis, elevator access was not included. The maximum walk up situation used was 4 flights of stairs. For the most part this thesis deals with stable slopes due to the extreme and unique problems associated with unstable slopes.

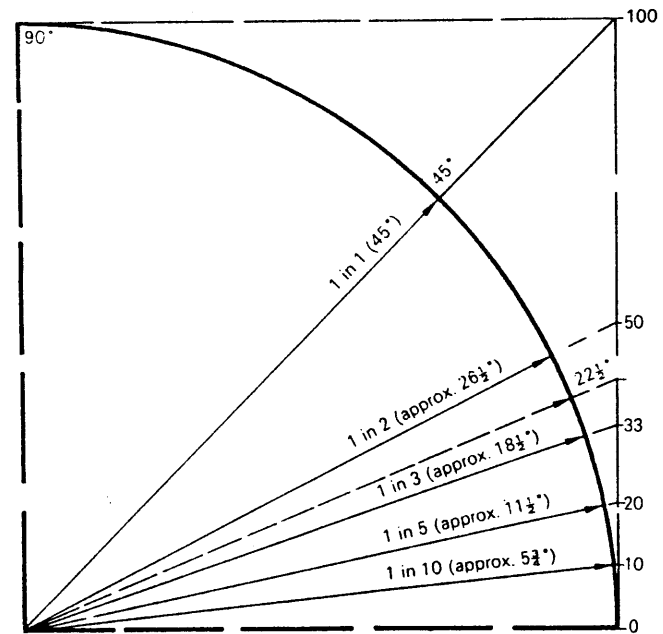

Gradient	(45°)	Angle	Classification and use
1 in 1	100	45°	Very steep (38-42° \angle repose: rock embankment)
1 in 2	50	approx. 26½°	
1 in 3 1 in 4.5	33 22	approx. 18½°	Steep (max. slope: grade IV agricultural land)
1 in 5	20	approx. 11½°	
1 in 10	10	approx. 5¼°	Moderate (max. slope: pedestrian ramps, prams, etc.) (max. slope: forest roads)
1 in 20	5	approx. 2¾°	
1 in 60	1½	approx. 0.43°	
			Gentle (max. slope housing without special provisions)

Figure 2. Slope Classification Chart
(Abbott and Pollit, p.135, 1972)

STEEP SLOPE ISSUES

LANDSCAPE PRESERVATION

Building on steep slopes is likely to be at odds with preserving landscapes. Three factors cause the principle damage to the land. These are building access roads, installing infrastructure (in particular fresh water and sewage), and setting foundations. Hillsides are prone to erosion and their natural beauty is a hard act to follow, as well as being difficult to recreate once it has been destroyed.

A first minimum criterion for landscape preservation at the building or lot scale, is whether the hillside is damaged in a way that promotes erosion or landslip. Are embankments overly steep?

Is there sufficient groundcover to protect the topsoil? Is there enough topsoil to grow groundcover?

Perhaps the most difficult criterion for landscape preservation which can be applied is whether the house fits in with and enhances the hillside? Of course the visual appeal of a structure can be subjective to the point of uselessness, but it does provide some direction. One contention is that the house should tuck into, or have repose on it's site. Then again, maybe a building can provide a counterpoint to the hillside? Perhaps it's silhouette should reflect the outline of the hill, perhaps it should be light and airy, or, if the slope is steeper, to reflect the fall away feeling of the land?

A building which tucks into the land must somehow blend into the hill. The

objective is to try and develop some interchange between the euclidian forms of the buildings and the natural, informal vegetation and landform. One of the more successful techniques for making the house seem a normal and smooth outgrowth of it's hillside environment, is to treat it as a concentration in a continuous system of retaining walls and terraces. Schindler and Wright's work both contain good examples of this. Schindler's projected house for W.J. Delahoyde in Los Angeles illustrates how the house can connect to it's hill and street surroundings through the use of retaining walls. Figure 3. As housing density rises, however, above 10-15 units per acre, it is very hard to fight the image of landscape between houses rather than houses in the landscape. Another approach is to bury

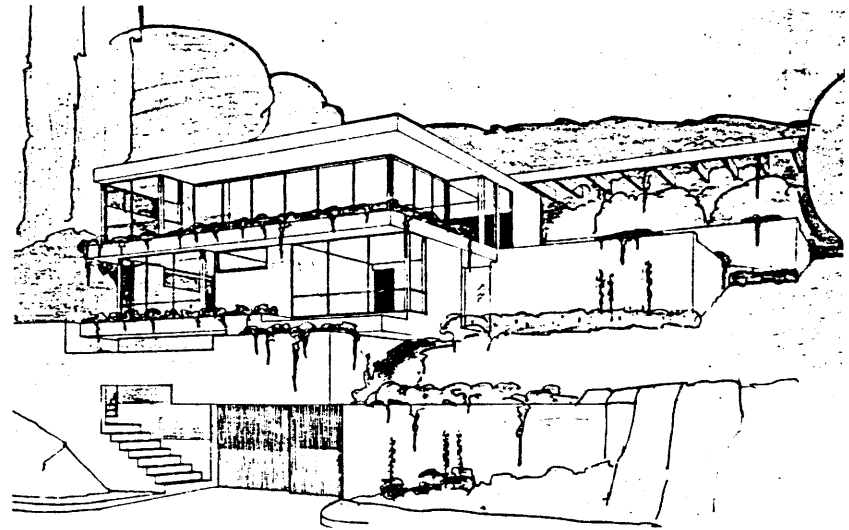

Figure 3. Projected house for W.J. Delahoyde
Arch: R.M. Schindler, L.A., Cal. 1935
(Gebhard, p.135, 1968)

the house. There may be energy saving advantages with this approach, but there are also constraints on large excavations when the slope is steep. A building which provides a counterpoint to the hill, usually does so in an effort to obtain a good view. Many houses like this may destroy whatever view there is.

Gruen Associates suggests these as some important problems for hillside housing:

- 1.) The location, design, and care of open space.
- 2.) The treatment of cut and fill slopes.
- 3.) Architectural harmony between houses, and houses and hill.
- 4.) The preservation of the hill

These problems can be restated as landscape design which pertains to the space between buildings, architectural design which is the houses, and maintaining a dialogue or connection between the two in order to ensure harmony of the whole. The preservation of the hill character is the most important problem here, and is the sum total of the

others. The special qualities of living on a hill are easily lost under the heel of development. Understanding of the hill's character is not enough.

Developers, architects, and engineers must have conviction that preservation is a goal worth fighting for.

Maintaining planting areas, and cluster housing are two obvious, partial answers to this problem. The vegetation should be planned and allowed for, because it is the material which will protect most of the hillside from erosion, and give visual relief from the built landscape. Vegetation systematically mixed with the housing claims the housing as part of the hill. Hillside seem to be ideal locations for the practice of cluster zoning, since it is inherently easier to concentrate building on the less steep,



Figure 4. Brutal transformation of a hillside.
(Bronson, p.95, 1968)

stabler areas, leaving difficult ground untouched. (1) The affect of the cluster housing is to sidestep the problem by concentrating the housing in one area,

leaving larger spaces as open landscape. Untouched land can be set aside as a public landscape, or "scenic easements."

(1)
Hillside Studies and Legislation Across
The United States

DENSITY AND SLOPE STEEPNESS □

On a large scale, the scale of a valley or a mountain, landscape preservation is achieved by limiting density. There are two arguments for this.

Visually, an untouched hillside can have great natural beauty. A certain number of houses can be added to a hillside before it might be said to be "covered by houses", and thereby rendered unattractive. The judgment of how many is too many is completely subjective, depending on the viewer, the architectural quality of the houses, the particular landscape, etc. There is some median number of houses that a majority might agree upon. The townspeople of any given locality must decide what this density is.

Practicing standard subdivision techniques on hillsides can result in abominable landscapes such as the one illustrated in figure 4.

Secondly, safety is affected by density in two ways, both of which can lead to catastrophic slope failure depending on the specific geology. Safety is integrally related to the geologic stability of a site. The added weight of a building can overburden a marginally stable hillside, increasing the risk of slope failure. A group of buildings built close together may work in concert to increase this risk. By controlling density this risk is reduced. Building on slopes can also cause disastrous erosion problems, which can undermine huge tracts of land, roads, or buildings. Natural drainage patterns are disturbed, both

underground and on the surface. Improper drainage can easily destroy a sound foundation. This problem is exacerbated by high density because of increased runoff. (see below)

Extensive work has been done in the area of limiting density on steep slopes. An example of zoning guidelines for limiting density is shown in figure 5. This graph shows density decreasing as a function of slope, and dropping to zero at 22° or a gradient of 40%. As the lot size increases, the density drops off. Guidelines vary from place to place. No land over 19° (35%) should be permitted to be developed except at the specific discretion of the City. (1) Grading controls are particularly important. For

more information the reader is referred to the publication "Hillside Studies and Legislation Across The United States". Zoning can and has been enacted which identifies areas that may have stability problems, but the best bet is to consult a geologist for each site.

In both developing guidelines for a region, and building on a specific site, the advice of a geologist or geotechnical engineer is crucial. His is the task of seeing what cannot be seen, the inside of the hill, and making a judgement about how and if a building can be secured on it.

(1)
Duncan and Jones, 1969

SLOPE/AREA DIAGRAM

BASED ON SOIL & TOPOGRAPHIC CONDITIONS

VILLAGE OF ROSLYN

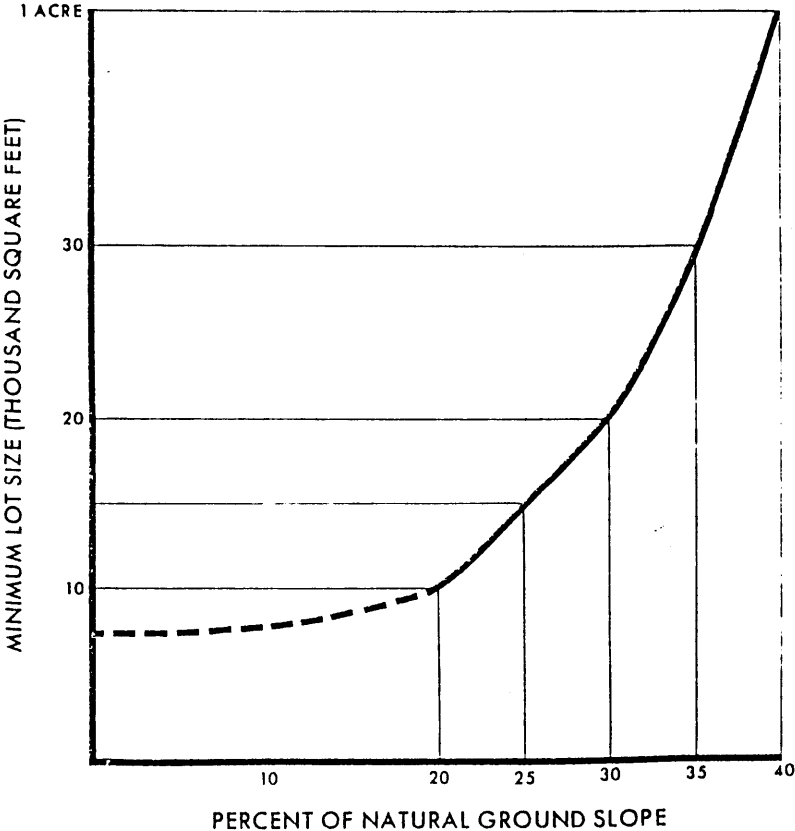

Figure 5. Zoning to limit density on steep slopes. (Frederick P. Clark Associates, 1972)

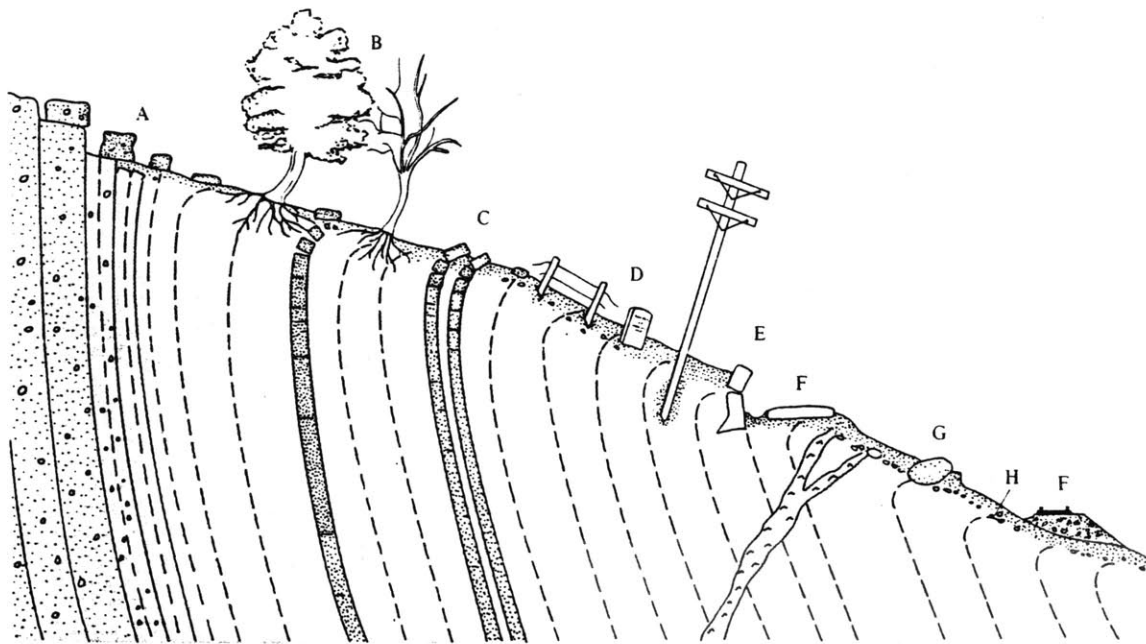

FIGURE 2-31. Evidences of creep. (A) Moved blocks; (B) trees with curved trunks concave upslope; (C) downslope bending and drag of rock layers, fragments present beneath soil elsewhere on the slope; (D) displaced posts, poles, and monuments; (E) broken or displaced retaining walls and foundations; (F) roads and railroads moved out of alignment; (G) turf rolls downslope from creeping boulders; (H) stone-line at base of creeping soil. (A) and (C) represent *rock creep*; all other features are due to *soil creep*. (After C. F. Sharpe, "Landslides and Related Phenomena.")

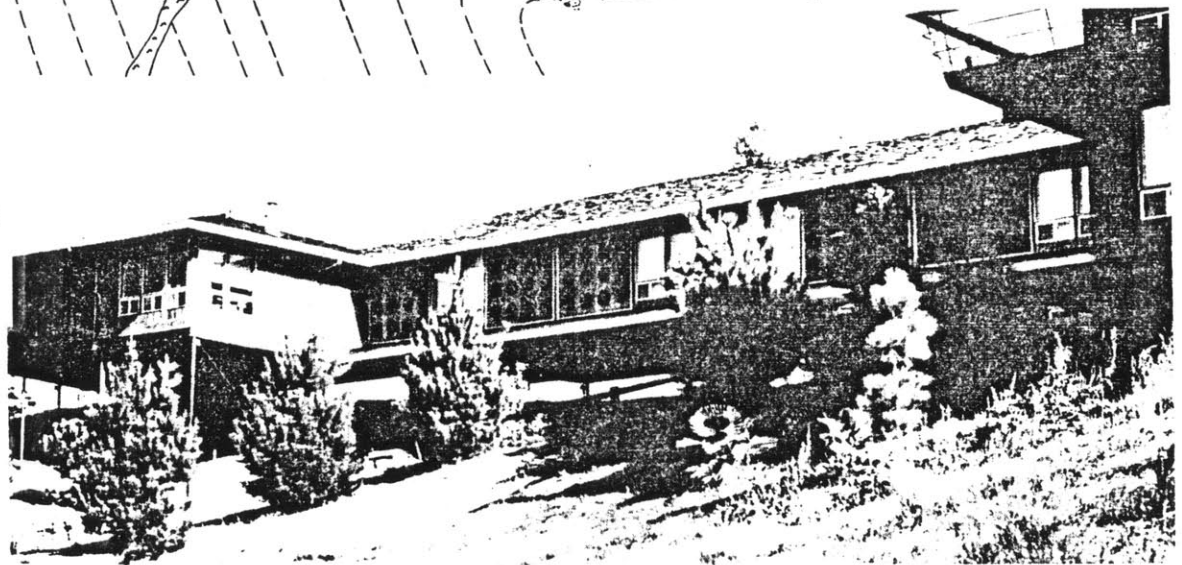

FIGURE 2-32. Residence bridging a swale mantled by creeping soil, Los Altos Hills, California. The creeping soil is up to 3 m (10 ft) thick beneath the structure, which is supported by steel columns. (Arthur D. Howard.)

Figure 6. (Howard and Remson, p.45, 1978)

Figure 7. (Howard and Remson, p.45, 1978)



The choice of foundation system depends heavily on the geology of the site. Geology is characterized by the soil(s) present; rock, clay, sand, ..., and the process by which those soils came to be there. Their history determines whether hillside soils will be stable, marginally stable, or unstable. Most hillsides are in the marginal range of the stability continuum, meaning that there is a limit of safety for building. This is due to forces such as gravity perpetually acting to flatten the hills down. A slow process of change is everpresent. Repercussions of even a small act can spell disaster by accelerating the rate of change. Rock is the most stable possibility, though even rock may have

fracture mechanisms which will cause collapse. Signs reading "Beware Falling Rock Zone" warn travelers daily of this type of danger. The stability of hillsides tends to get worse as the angle of incline increases. A very good synopsis of geology and mechanisms of slope failure is available in Abbott and Pollit (1980). It is important to understand the geology before any changes are made to a site.

As an example of how understanding the geology can be addressed in a design to provide safety, the reader is referred to figure 6 which illustrates characteristics of a creeping soil. A response sensitive to the presence of a creeping soil is shown in figure 7. The house hovers above the site allowing the soil to creep freely downhill. No common

intervention would survive the soil movement in such a situation.

WATER AND EROSION CONTROL

Dealing with water is one of the most important safety issues for a hillside building project. Geologic stability can be closely dependent on soil water content and water movement. Water moves down a hill in two ways, by flowing over the surface, or by slowly seeping subterraneously. Erosion control is mostly concerned with protecting the soil from the action of surface water. Surface water is characterized by its' quantity and flow velocity. Quantity is generally controlled either by containment (storm drains), or diversion. Retention is also important in general, but may be difficult

on steep hill sites. Velocity is controlled by reducing the angle of incline and/or increasing the roughness of the surface over which the water is flowing. Large stones in a runoff channel slow down flow more than the smooth walls of a concrete culvert.

Since houses and driveways are impermeable to rain, runoff will be concentrated near the buildings, increasing the potential for erosion. Once the erosion process has begun on a steep hill, it can be very difficult, and perhaps impossible to stop. Slope failures are much easier to prevent than to repair.

Foundation walls disrupt the flow of underground water, and if not provided with adequate drains, can act as dams, causing the build up of large hydrostatic

pressures, which may crack walls, topple walls, and aid in pushing buildings down the hill. Figure 8. The worst situation occurs when catastrophic failure is induced, such as landslip. A good foundation does not cause an excessive change in the pressure distribution of the hill. Draining away subterranean water prevents this danger. This process is the same for retaining walls. Without proper drainage, large overturning forces develop due to a combination of soil and hydrostatic pressure. Perforations or weep holes in retaining walls allow water to flow through. Water flowing under retaining walls promotes slope failure.

Generally it is beneficial to get water off the hill, but it is equally important that there be enough water for the vegetation to grow, which is vital for

holding the soil in place. Native plants may be the best choice for erosion control since they are adapted to climatic extremes.

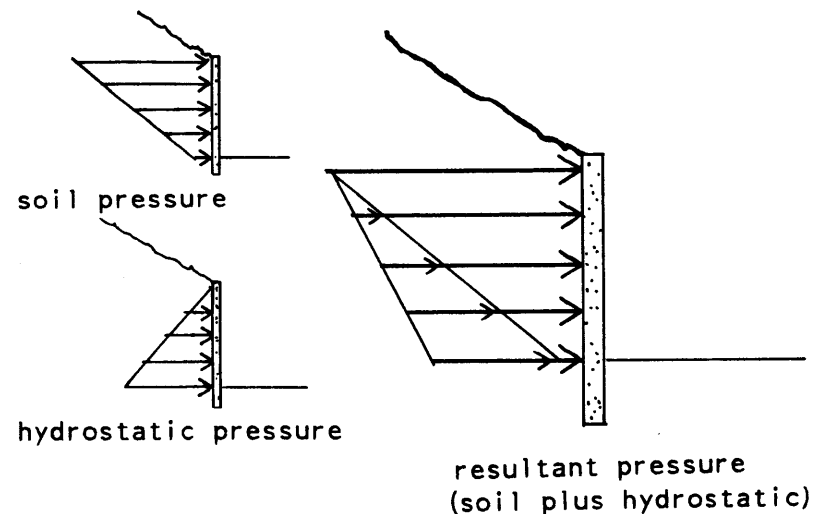

Figure 8. Build up of hydrostatic pressure.

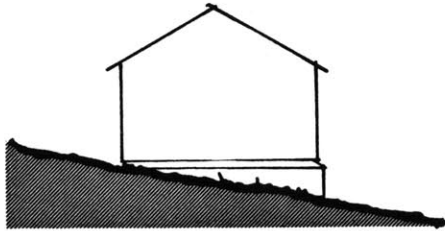

Figure 10. Progressively buried plinth
(slopes under 10°)

BUILDING SYSTEMS

Building systems for hillsides are presented in figure 9. The matrix of Building Systems v.s. slope angle is organized in two parts: the first five approaches primarily alter the hill, while the last two, Pier and Grade Beam, and Pole, can be used to prop an existing design up off the hill. Some gross limits imposed by geologic incompetency are indicated, and impossible diagrams are omitted. An exhaustive survey of building methods v.s. the great variety of geologic situations is beyond the scope of an architecture thesis.

Approachs to building on hillsides fall into three basic categories; altering the slope to suit an existing design, propping an existing design up off the

hill, altering a design to fit onto a slope, or any combination of the three. Altering the slope yields savings in design time, because an existing flatland design can be readily employed.

Propping an existing design up off the hill is a very common solution on slopes shallower than 10° . It can be as simple as adding several extra courses of masonry, or as complex as building a platform on which the house is placed. Often the building is placed on a plinth, which becomes progressively buried as it moves into the hill. Figure 10. The plinth resembles a wedge which makes up the difference between the hill angle and the horizontal base of the house. As the slope gets steeper, past an angle of 20° , the advantages of simply altering the hillside become much less attractive.

Figure 9. Building Systems v.s. Slope Angle

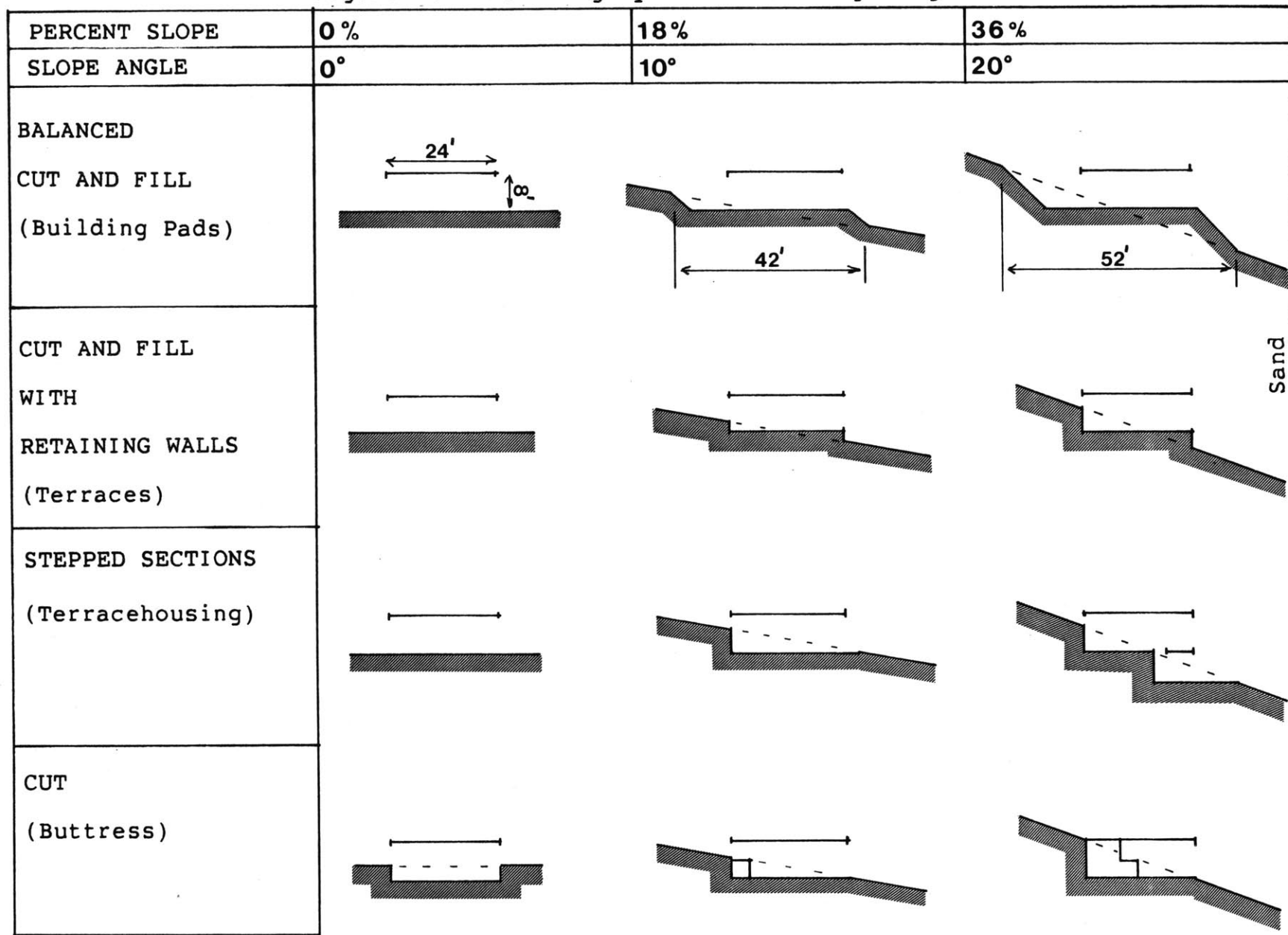

Sand

58%	84%	119%	∞%
30°	40°	50°	90°

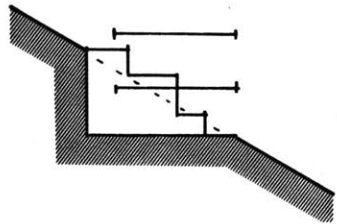
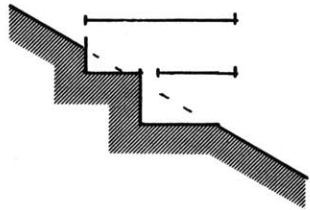
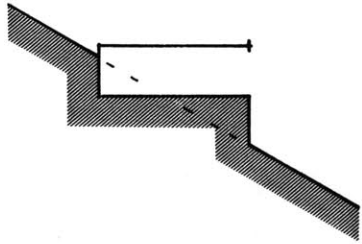
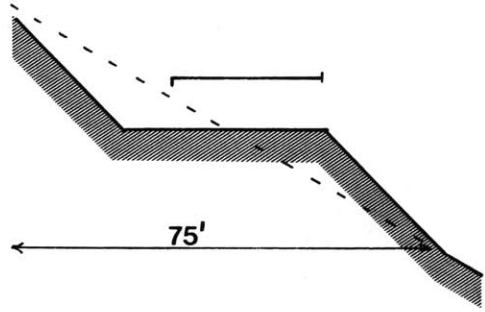

Clay

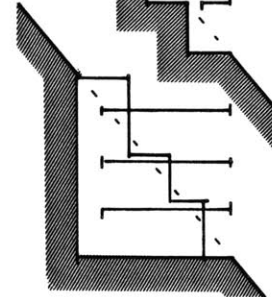
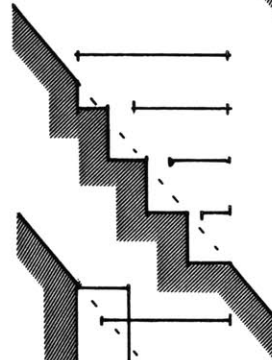
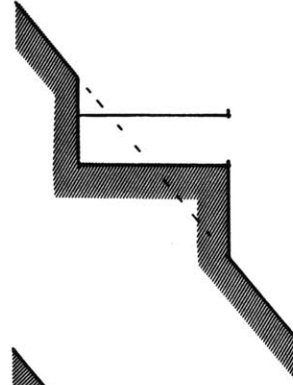
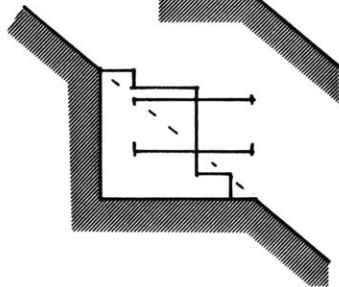
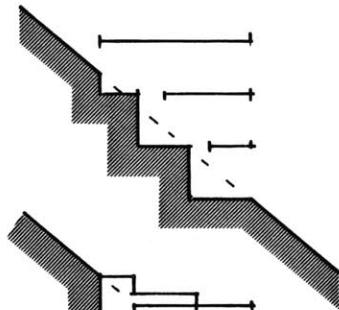
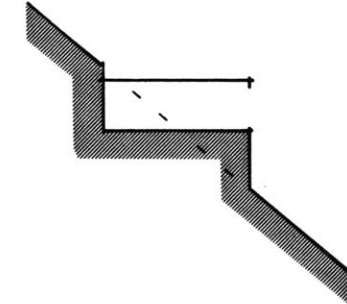

Solid Rock

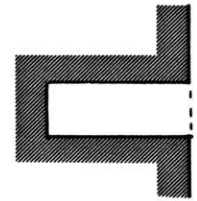

Figure 9. Building Systems v.s. Slope Angle (continued)

PERCENT SLOPE	0%	18%	36%
SLOPE ANGLE	0°	10°	20°
FILL			
PIER AND GRADE BEAM			
POLE STRUCTURES (Propped Up)			

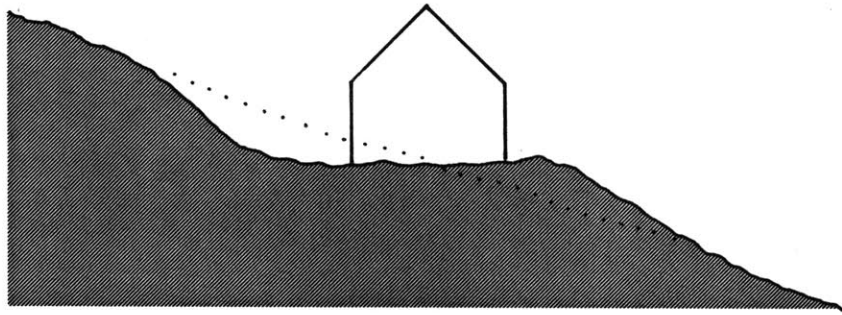

Figure 11. Cut and fill building pad

BALANCED CUT AND FILL

The simplest and cheapest alteration of a slope is the cut and fill building pad. Figure 11. A level shelf is cut into the hill, the grade change being taken up in the form of steep embankments, uphill and downhill of the shelf. This method is limited to slopes of at most 30° by the natural angle of repose of the particular soil(s) present. (1) Figure 12. This angle of repose can be extended a little by special treatment of embankment surfaces. Normally a cut slope may be as steep as 45° whereas fill slopes are limited to 26° dependent on soil type.

Construction of the cut and fill pad

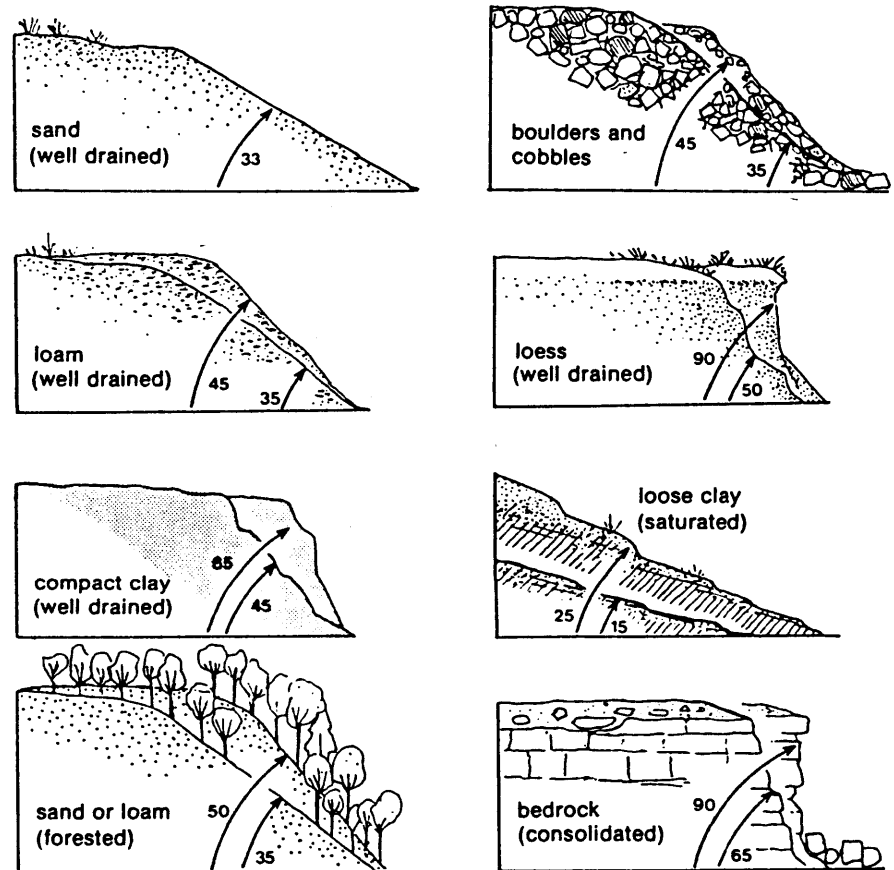
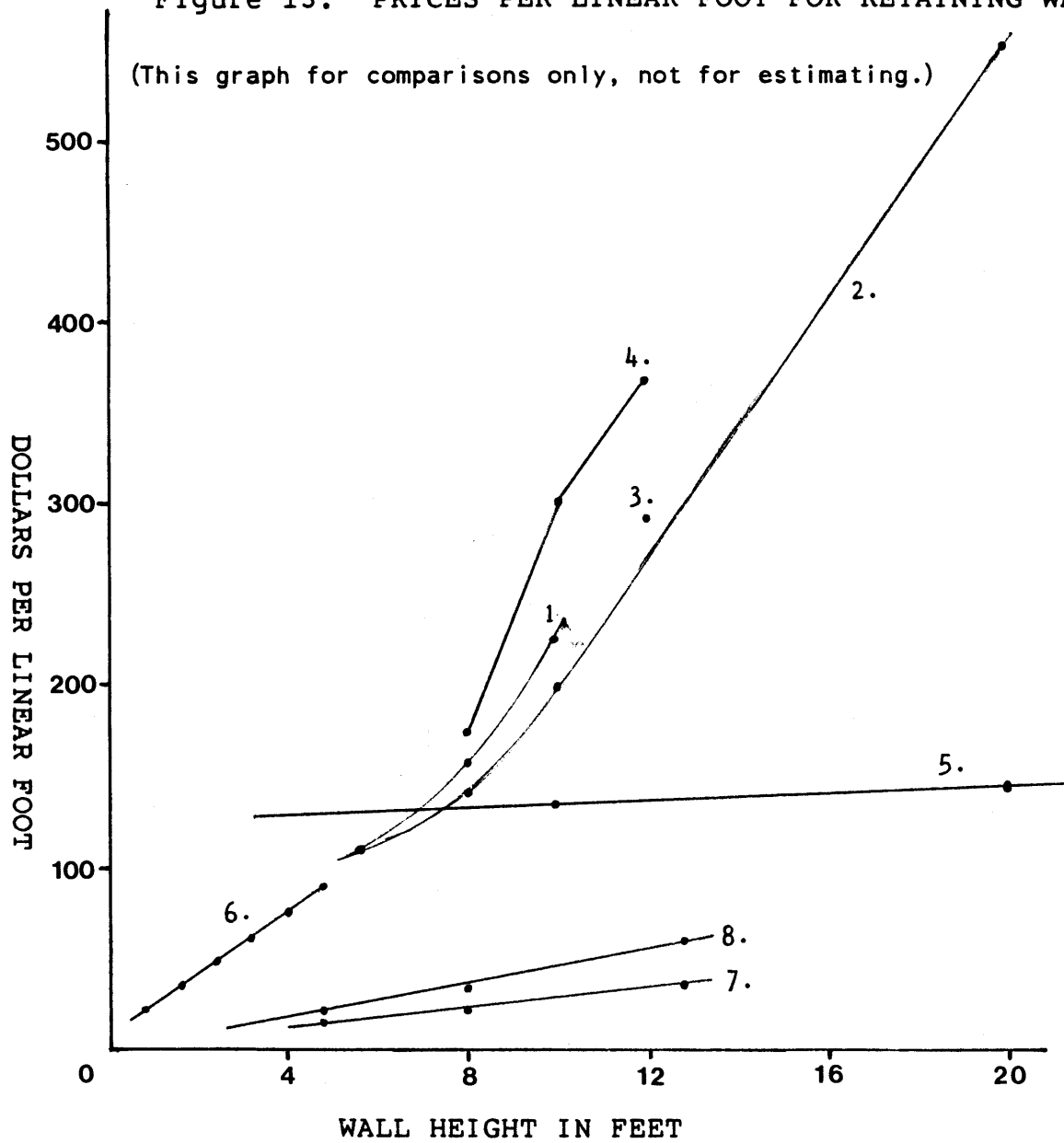

Figure 12. Angles of repose for various types of slope materials. (Marsh, p.208, 1983)

(1) Maximum grade for unmown planted banks is 50 - 60%, (27° - 30°), Lynch and Hack, p.456, 1984

Figure 13. PRICES PER LINEAR FOOT FOR RETAINING WALLS

(This graph for comparisons only, not for estimating.)



1. Gravity concrete with vertical face

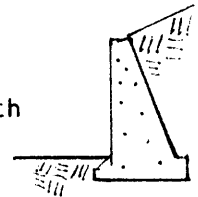

2. Concrete cantilever

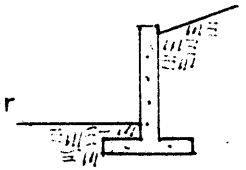

3. Concrete cribbing

4. Galvanized steel bin wall

5. Wood deck

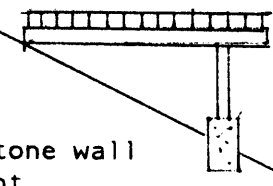

6. Decorative stone wall
6' max. height

7. Cut

45°

8. Fill

45°

begins to get difficult at a slope of 9°, above which many pieces of mechanical equipment cannot operate freely. (1) This inaccessibility contributes to higher costs. As the slope gets steeper, the volume of soil involved increases and the extent of the excavation increases. On a 30° hill, half of the land affected is left in an unuseable condition as steep banks, leaving half as level ground. This conservative estimate is based on artificially increasing the angle of repose of the soil to 45°. Figure 13 illustrates the low construction costs of this simplest cut and fill method with other methods for establishing horizontal levels on a hill.

Typical sections from the City of

(1) Simpson and Purdy, p. 78, 1984

Brea, California's Hillside Policy study indicate that slopes up to 20° can be dealt with quite effectively at lower densities, (figure 14) though they discourage the use of building pads because they do not promote overlooking which provides uphill houses with an unobstructed view.

Visually a slope transformed into building pads can be detrimental to the overall landscape of a hillside, because the "alternating sequences of flatland and uniform banks results in monotony and blandness." Figure 15. The resulting regularity clashes with the natural contours of a hill. It is at the point where new fill meets existing landscape that problems arise. (1) Care should be

(1) Gruen Associates, p. 22-23, 1965

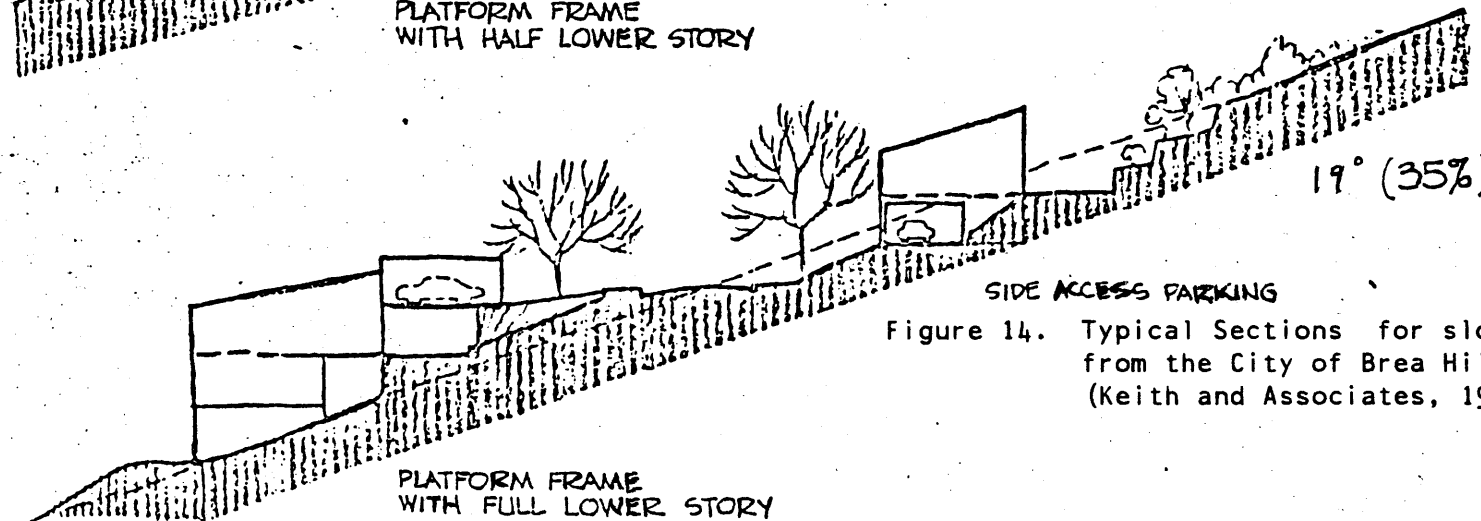
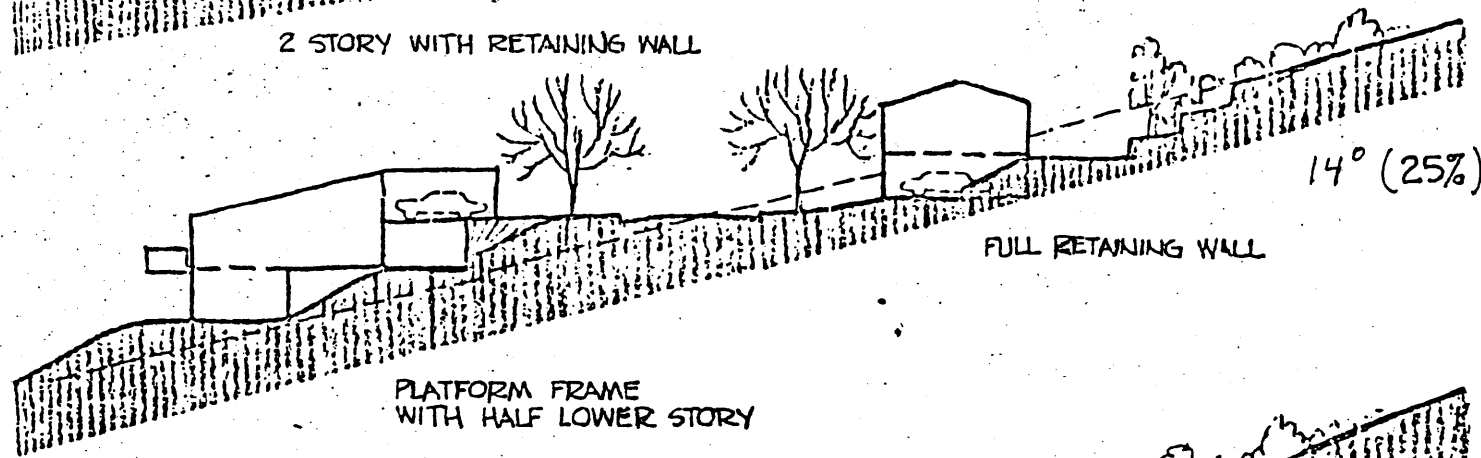
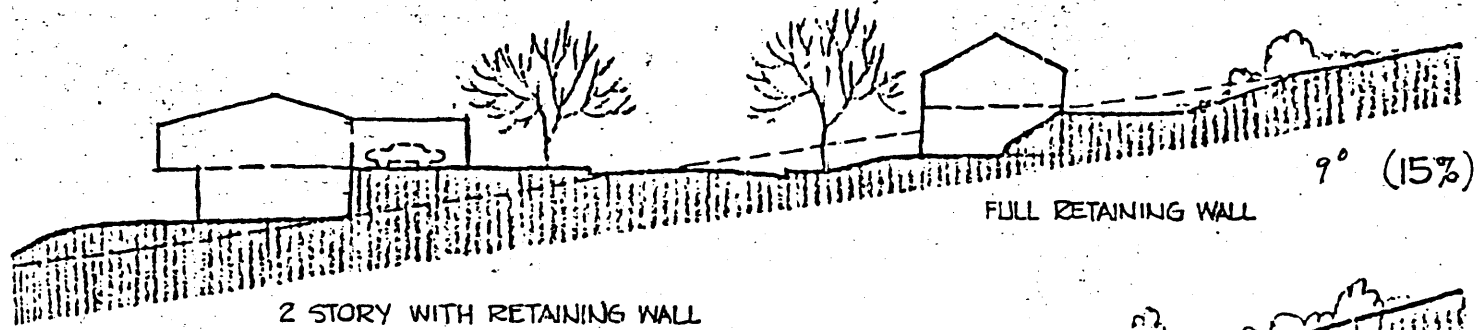
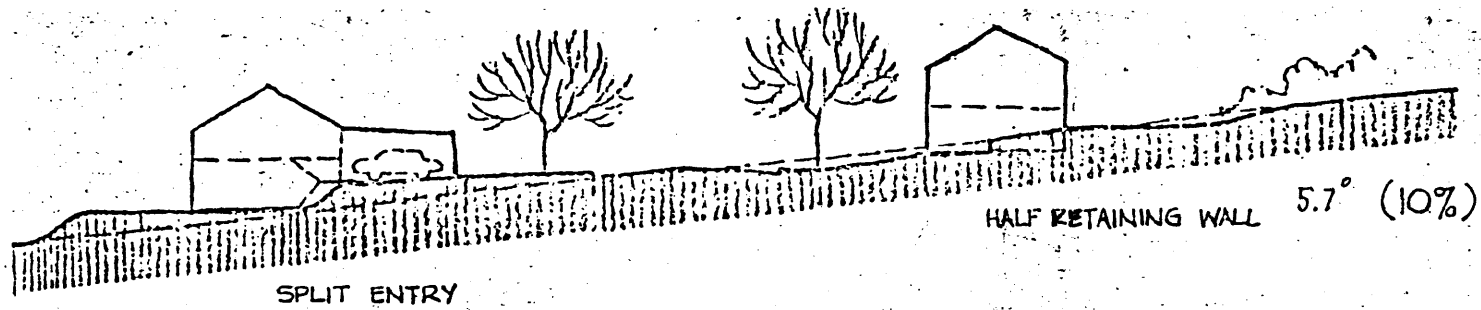

Figure 14. Typical Sections for slopes under 20° from the City of Brea Hillside Policy (Keith and Associates, 1975)

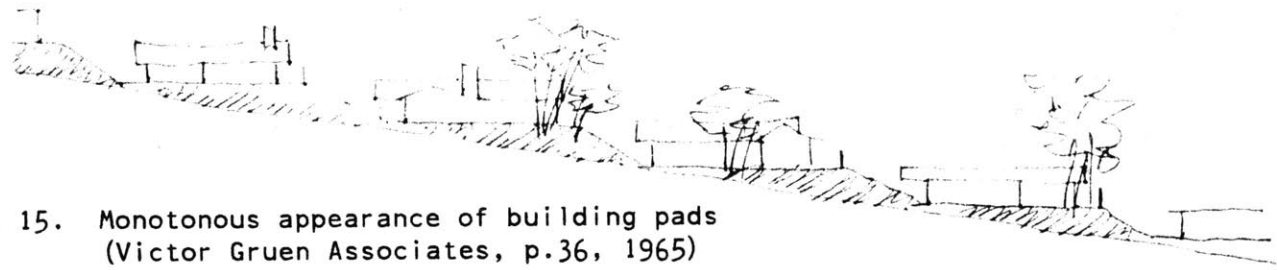

Figure 15. Monotonous appearance of building pads
(Victor Gruen Associates, p.36, 1965)

taken to disturb the existing landscape as little as possible and to blend in the cuts and fills.

This pad system requires changing the grade of large areas of the hillside, and obliterates much of the existing vegetation. Selected trees can be preserved, despite grade changes, but the techniques required can be costly and are usually awkward. Figure 16. Care must be taken to avoid erosion of newly made steep banks, which could be detrimental to neighbouring areas both uphill and down.

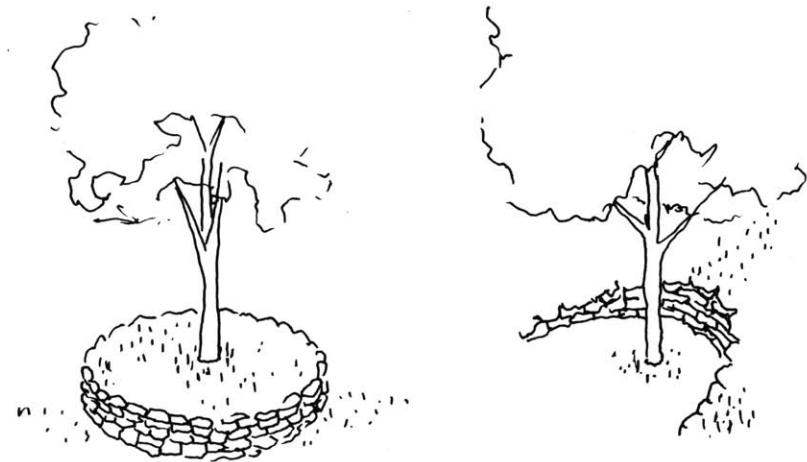

Figure 16. Technique for saving trees despite regrading, requires an area equal to the projected crown of the tree.

Access in this kind of a system is akin to that in standard subdivisions. Public rights-of-way are generally no steeper than 10%, with notable exceptions in California. The orientation of roads on steeper slopes will be generally along, or at a diagonal to the contours. This implies a need for long steep driveways to access individual sites, and an overall low density. Curbside parking will increase the density to around 12 d.u./acre. See appendix figure 86. The low cost of creating a building pad may be offset by the high cost of the access road being divided among fewer buildings.

The pad method gives the freedom of orienting the house regardless of the contours, so good solar access should be possible. The slope of the "level" part of the pad is under 10', so daylight

should be available on four sides of the house and on all levels. The system requires a liberal amount of space on all sides of the house so privacy should be easy to preserve. As the slope gets steeper, overlooking problems are minimized by long embankments between houses.

In general this method requires a radical change to hill contours. The problems associated with this system are exacerbated greatly as the slope gets steeper, making this a minimal solution to building on steeper slopes.

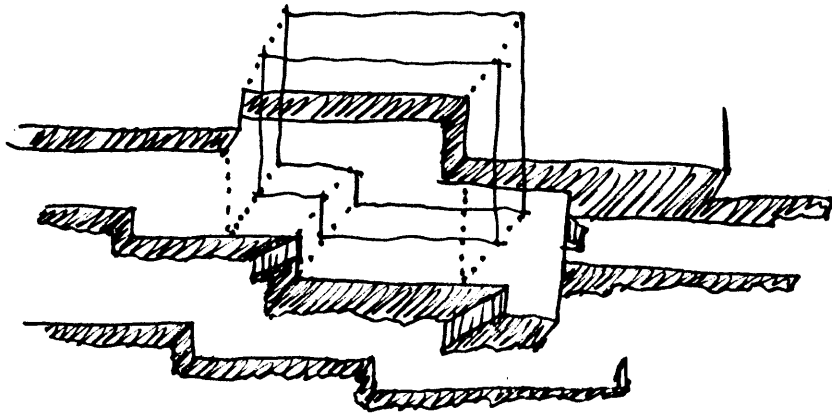

Figure 17. House as outgrowth of retaining walls and terraces.

CUT AND FILL WITH RETAINING WALLS □

A logical development of the pad method is to use retaining walls instead of banks to take up the grade changes. The construction cost of building retaining walls is generally much higher than a pure earth moving operation. The use of terraces in conjunction with retaining walls makes the site planning more sensitive to the contours of the hill because a smaller area is affected. This means that more of the hillside vegetation can be preserved. Since less of the hill is affected, maintenance costs will be substantially reduced. (1)

It is easier to establish relationships between terraces than

between pads because the terraces can be built closer together. This means the site can be denser and more complex.

Banks can be used in conjunction with terraces to provide an interchange between builtform and landform. This will help make the building a part of the hill landscape.

The ground levels and foundation walls inside the building are akin to terraces and retaining walls outside. This makes possible inside - outside relationships and other continuities along the contours. The house can become an outgrowth of the retaining walls and terraces. Figure 17. This concept of building generates a house whose interior reflects it's nature of being built on a hill. A variety of terraces can appear in the house in the form of level changes.

(1) Victor Gruen Associates, p.49, 1965

This provides added richness in section compared to letting the basement or lowest level take up the change in grade. (Which is another option with this system.)

As with any cut and fill method, the filled area will be more prone to settling than the cut area, since the cut area has had more time and pressure to consolidate. Careful compaction may solve this problem or it may be possible to site the building exclusively on the cut area, leaving the filled area for use as outdoor space. Bearing can also reach down through the fill to undisturbed ground. Other solutions to this problem include terraces made either only by cutting, or only by filling. These will be discussed later.

Figure 18.

Terracing with retaining walls will provide more flat useable space on a given

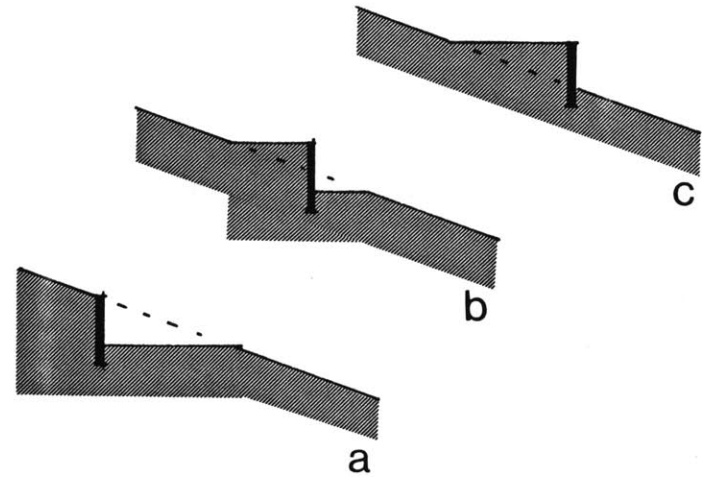

Figure 18. Three basic configurations of retaining walls.

amount of sloping ground than the building pad method because the long embankments are no longer needed to absorb the change in grade. The increased amount of useable space will help offset the cost of the retaining walls, especially if land value is high.

The unit cost for retaining walls takes a jump at around 4' and another at around 8'. The savings on useable land gained by using retaining walls are dubious if walls higher than about 8' are required. (1)

A unit cost analysis of retaining walls shows that at a slope of about 20° the cost of building a retaining wall begins to rapidly outstrip the cost of propping up a horizontal platform off the

hillside. Figure 19. Though these numbers are for outdoor space, they should be reasonably proportional to indoor construction, and provide a ballpark figure indicating when a designer should begin considering an alternative to a totally cut and fill system. The 20° intersection point on figure 19 coincides with the 8' tall retaining wall on figure 13. Curiously, this is also close to the height of one story. If one were to build a 24' wide house, a standard width using two 12' x 2" x 12" joists end to end, and assumed the back wall was completely buried, this would also correspond to a slope of about 20°. It would seem that a different system is appropriate at angles steeper than this. The logical next step is the stepped foundation.

(1) Victor Gruen Associates, p.49, 1965.

Figure 19. UNIT COST ANALYSIS OF SLOPE ALTERATIONS TO DETERMINE BREAK EVEN ANGLE

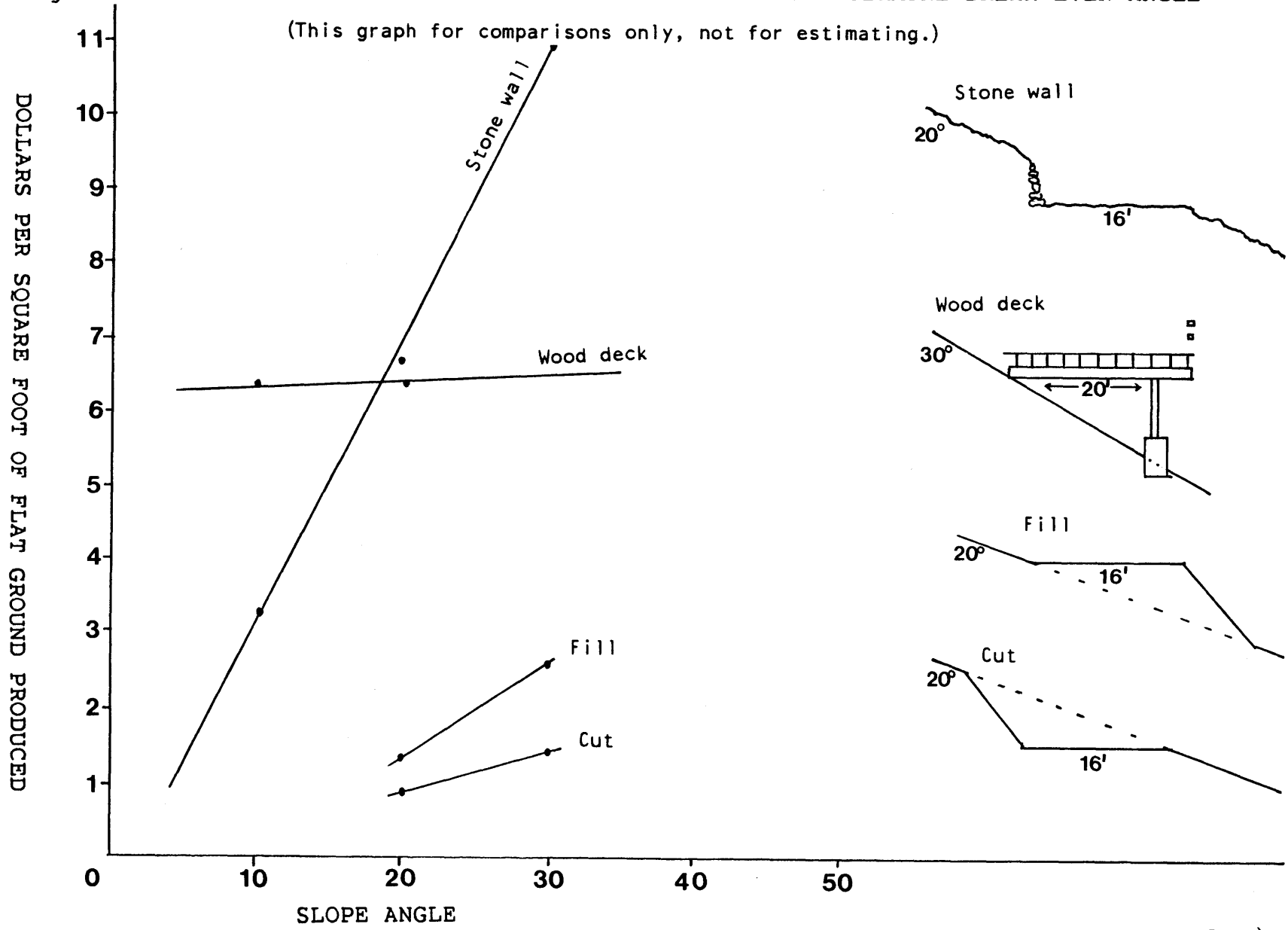

(All values taken from 1985 Means Cost Data)

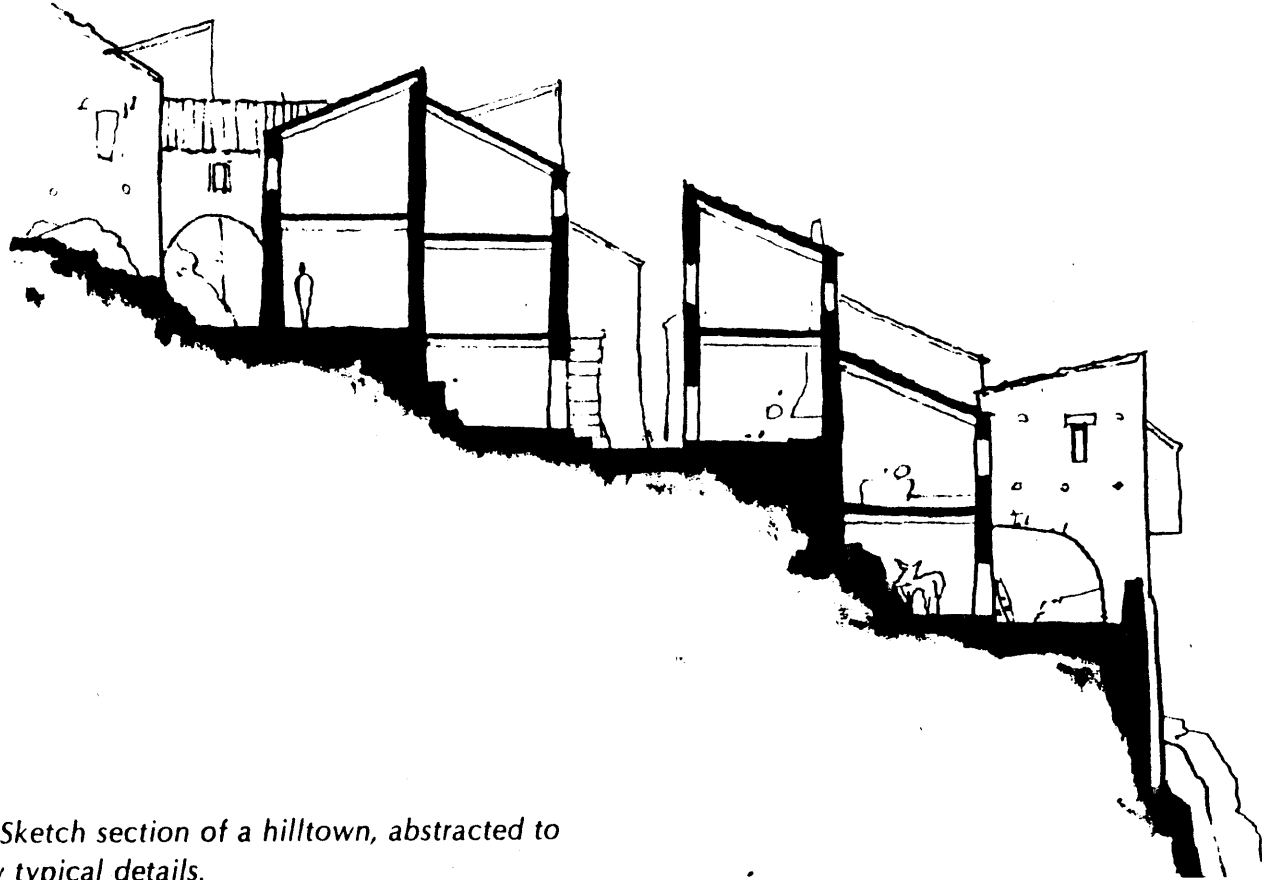

Sketch section of a hilltown, abstracted to show typical details.

Figure 20. Masonry bearing walls dictate slipping vertical volumes.
(Carver, p.118, 1979)

STEPPED SECTIONS

Stepping the section means splitting it's volume into two or more parts and offsetting them vertically. This vertical slippage can take place as a level change in a room, along a wall as in typical Spanish masonry construction (figure 20), or perhaps most easily along an access zone. The sliding zone can be of varying width when used as an access. The two most common widths are 3' and 6' as shown in figure 21. Six feet is half the run of a standard flight of stairs in a house with a floor to floor height of 9'. The split in the section can be an opportunity for visual, acoustic and physical connections between different levels. It can also serve as an organizer for the building.

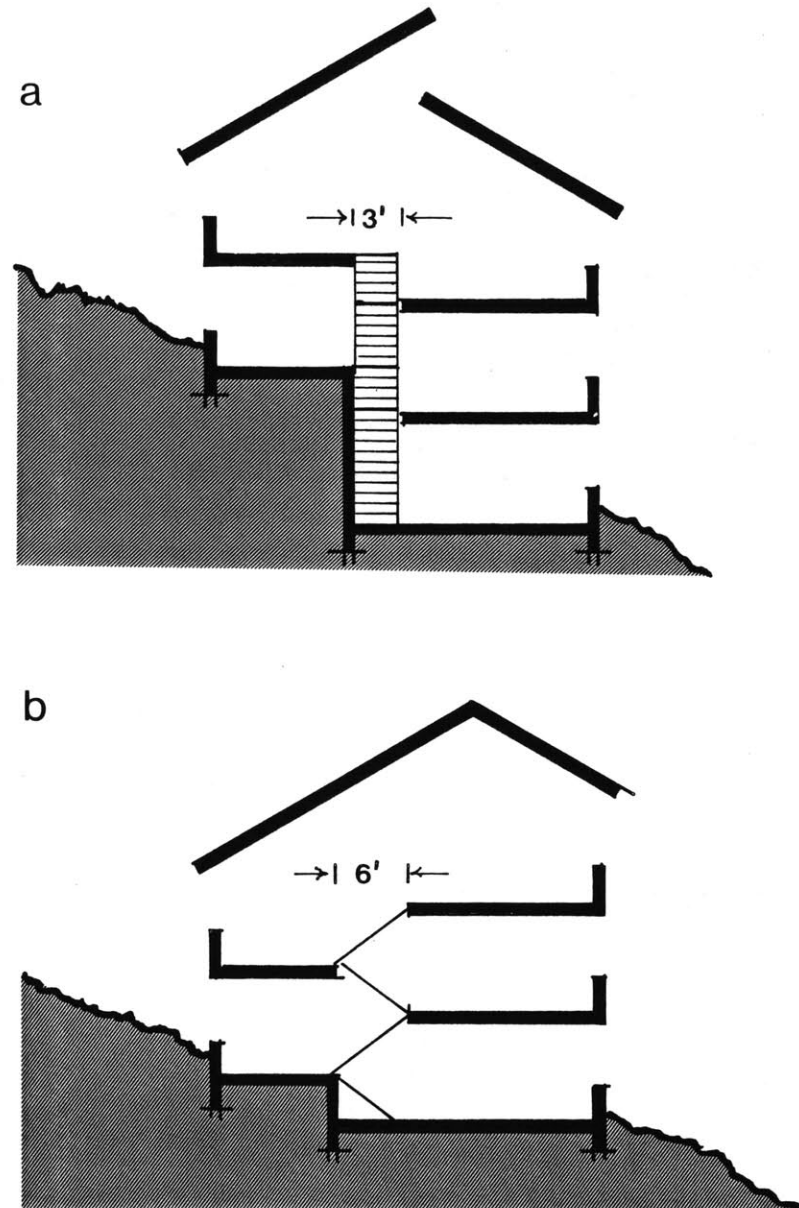

Figure 21. Access used as sliding zone to slip volumes vertically.

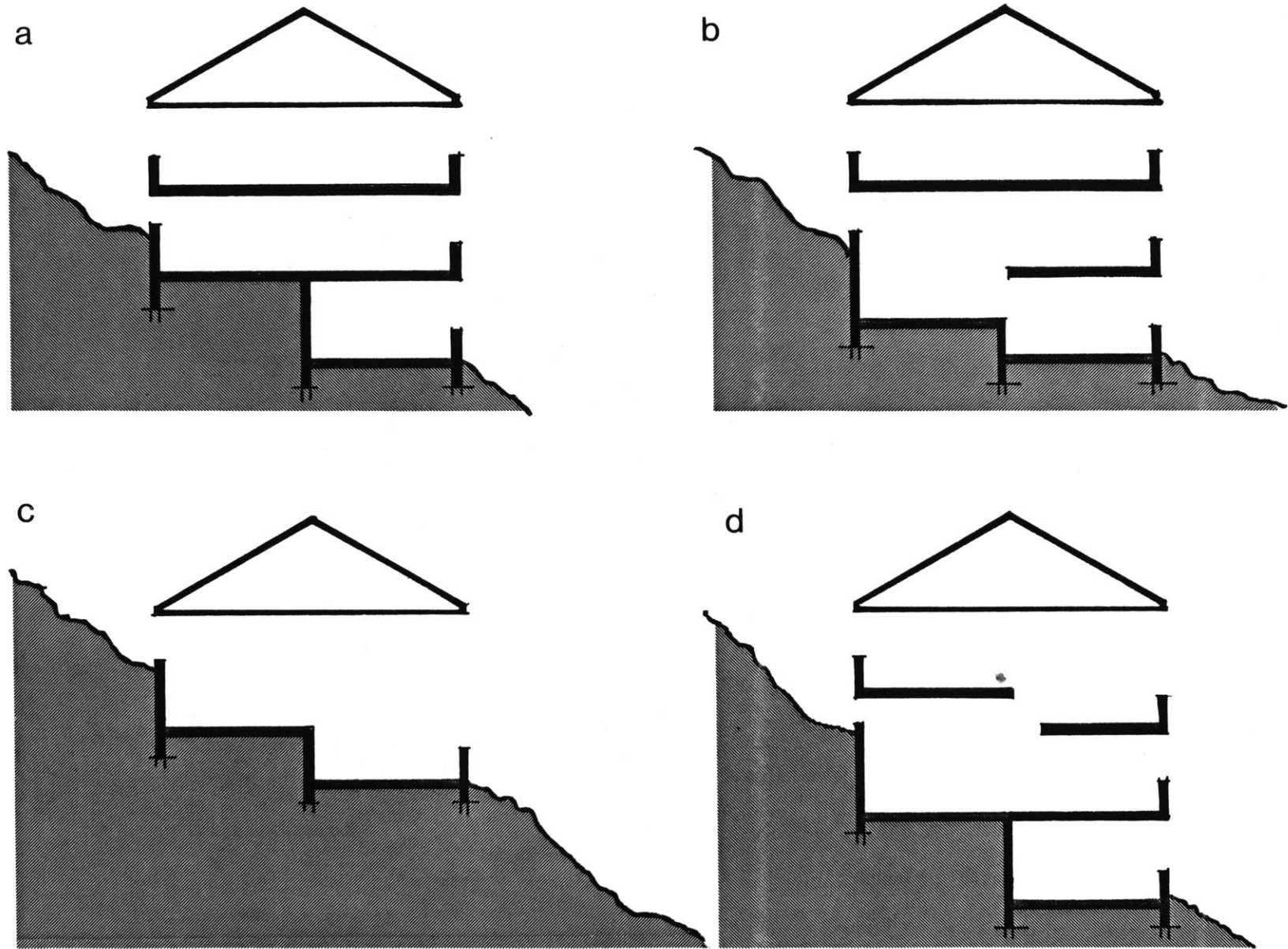

Figure 22. Variations of stepping sections.

A stepped section can be effective for lighting the backside of the hillside house, which tends to become buried as the house is set deeper in the hill. Figure 56. Though this buried condition may be appropriate for some uses, such as furnace rooms, it may result in other unfortunate spaces that need light. Furnaces do not require much space in a modern house. The need for spaces without windows is generally low, though some spaces may be successful without them. The approach of zoning spaces by their need for daylight is certainly a valid approach, and is commonly used in many apartment buildings. The slope is an opportunity, however, of making housing which does not resemble apartment buildings.

Stepping the section generates several basic variations at the ground

level. Figure 22. While many of these variations may allow lighting of the backside of the house, they may conflict with a desire to have single level floors. Single or through level floors might be desirable in elderly housing for example. There are several ways of providing through levels despite changes in section where the building meets the ground. The easiest situation is when the section is stepped by a full level as in figure 22a. Light can also be admitted by adding ceiling height along the back wall which will allow high windows to be installed. Figures 22 b,c,d. Figure 22d shows a method of resolving the split level section which creates a tall space on the second story with a view out over the hill.

The size of the steps in a section

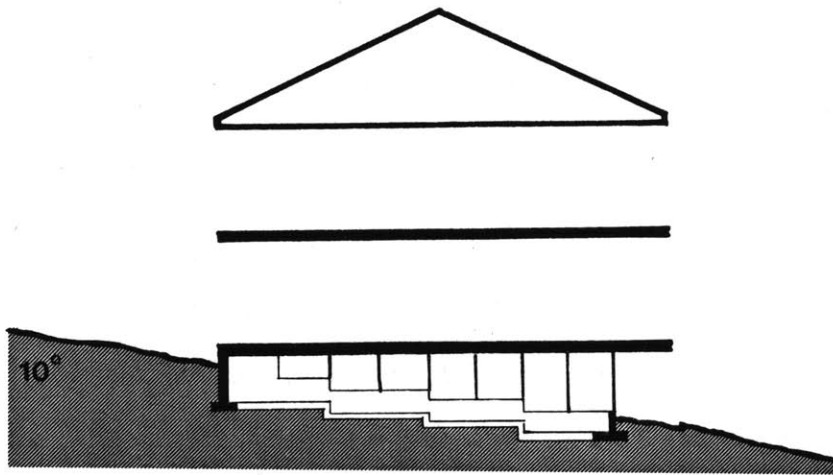

Figure 23. Modular stepped footings and split level house.

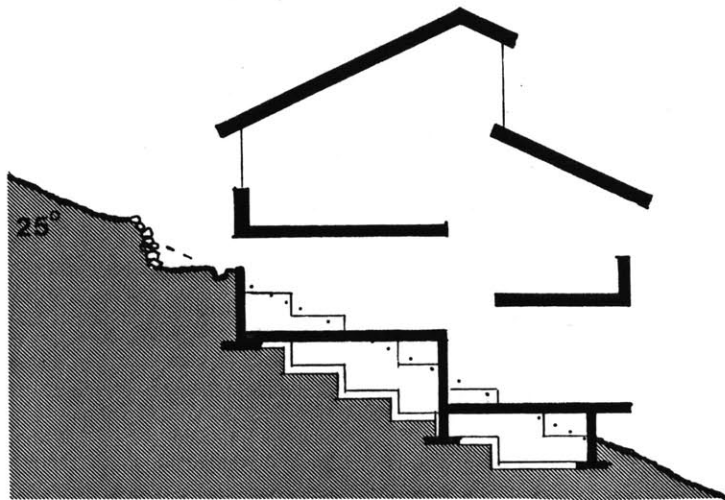
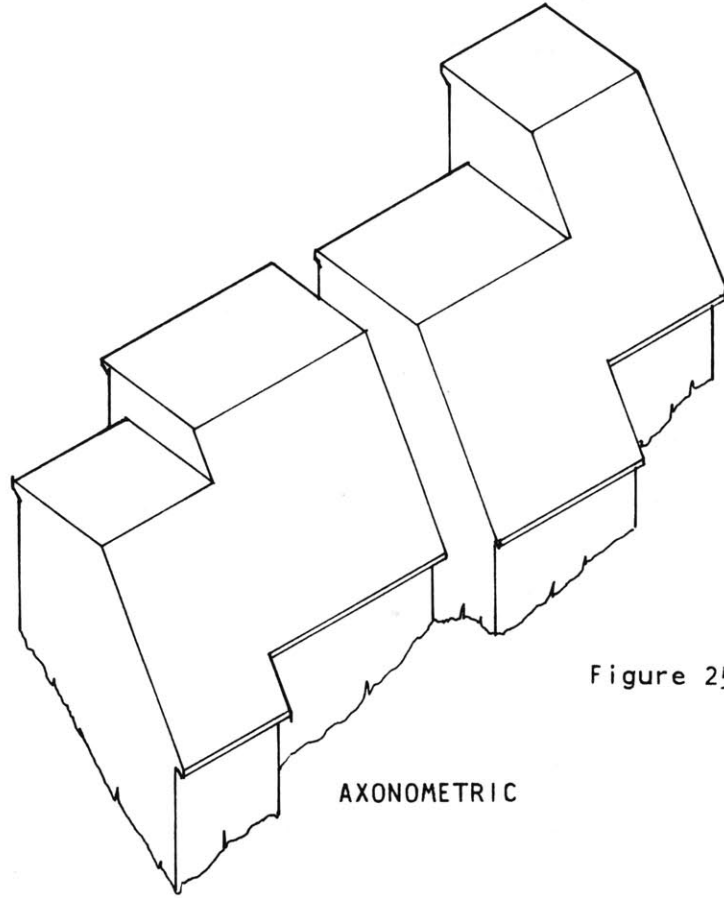

Figure 24. Modular stepped footings with single level house.

can vary from 6" to over a story in height. The modular stepped footing used by Spexarth is an appropriate way of building in small changes of level. (see appendix) It allows the floor to be closely fit to the contours of the hill. The result might be a series of small interior level changes, ranging in size from 6" to 24". The system can be used to create a split level house on slopes under 30°. Figure 23. On slopes of about 10° and under, it is possible to establish a single level house, with the odd underneath space left as slack, or as a progressively buried plinth. Figure 24. A secondary system must be introduced to take up the slack between the footing and the floor levels.

Perhaps the biggest advantage of this system is that it allows for on site



AXONOMETRIC

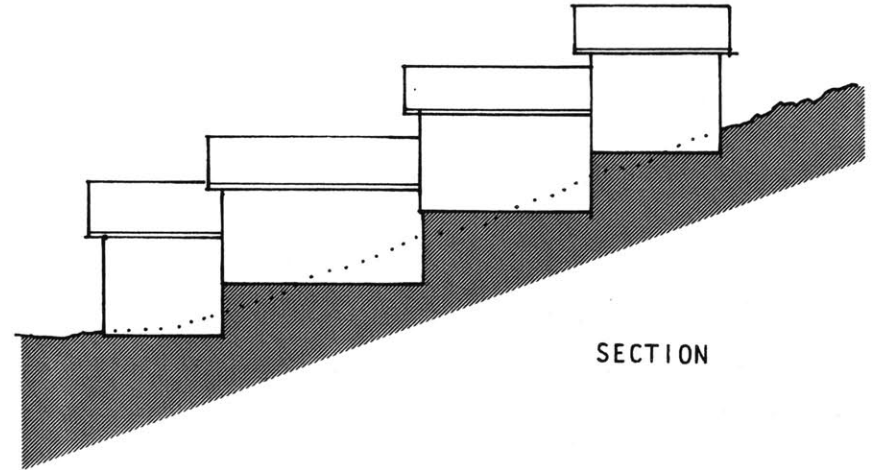

SECTION

Figure 25. Ranch house stepped up the hill.

alterations. This means the design need not be tightly tailored to the site.

Half level steps can be used to get light in without losing the sense of the larger space. Steps of this size are

compatible with a method for adapting a standard single story ranch house design to a hillside site. The ranch house is basically segmented along it's length with the pieces stepping up the hill. Figure 25. (1) Part of the appeal of a single

(1) suggested by Professor Waclaw Zalewski

story ranch house is that the ceiling of every room is the bottom of the sloping roof. These spaces are more interesting than the boxlike spaces typically generated in multi-storied buildings. If the typical ranch house is stepped up the hill room by room, the room-roof relationship is retained, the living pattern and room layout remain the same, and the access or corridor is transformed into a series of stairs and landings. This could be a very appropriate form for low density housing, and an interesting twist on a standard living pattern. This stepping technique can also be used emanating downwards from the access.

It also provides a method of orienting the house perpendicular to the contours without requiring large excavations, thus passing the criterion of

minimizing change to the hillside. Since the bulk of the house would be up the hill, the street could have a more open feeling. Zero lot line housing might also be adapted in this way. The modular stepped footing would be very compatible with this system. Expressing the stepped nature of the house can be very effective. Figure 26.

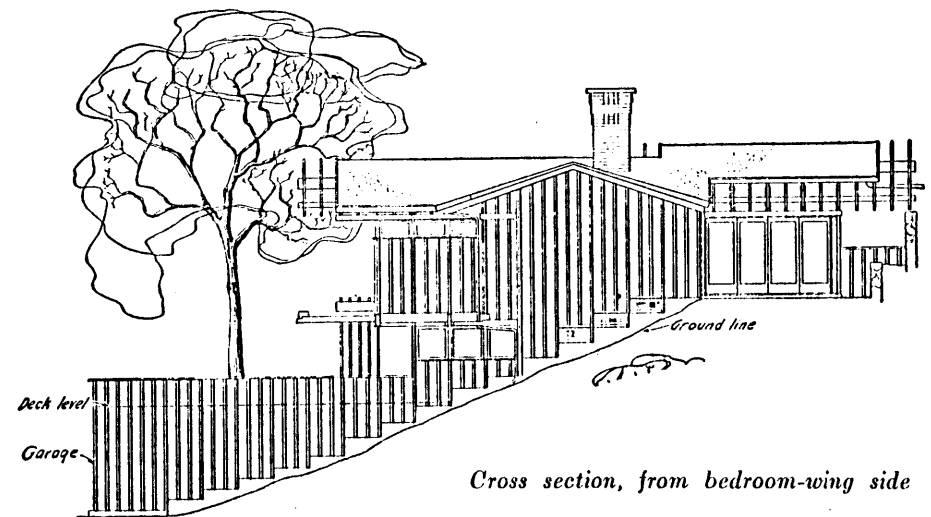

Figure 26. External expression of stepped footings. Designer Harwell Hamilton Harris. (Sunset Ideas for Hillside Homes, p.20, 1961)

The option of stepping by whole floors begins to be useful around 25° - 30° . This may result in the small lowest level being lit on one side only, or in the floors beginning to terrace up the hill and being lit generally on three sides only. Terracing floor by floor up the hill generates the Terracehousing form which has been used frequently in Europe, consisting of apartment flats stepping up the hillside. Figure 27. (1)

When a house is oriented perpendicular to the hill contours, it is possible to step the bottom of the house while leaving the top floors unstepped. (Many municipalities have 35' height limits which will restrict this). The

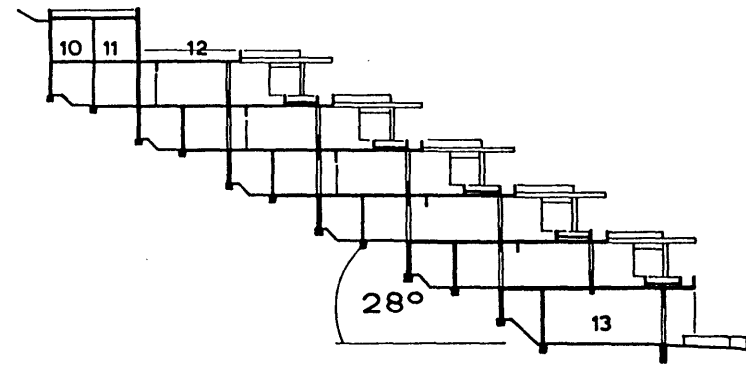

Figure 27. Terracehousing
(Riccabona and Wachberger, p.14, 1972)

full top floor provides lots of space and the possibility of entering the main uppermost living area on a single level from the car or street access. Figure 28. This is a typical situation in the rim type house which is built "over the edge" on the steep part of a slope, next to a flat shoulder. This type of siting leaves the flatter part of the site for yards and access. Building perpendicular to the contours leaves the long sides of the

(1)
See bibliography for references
to Terracehousing

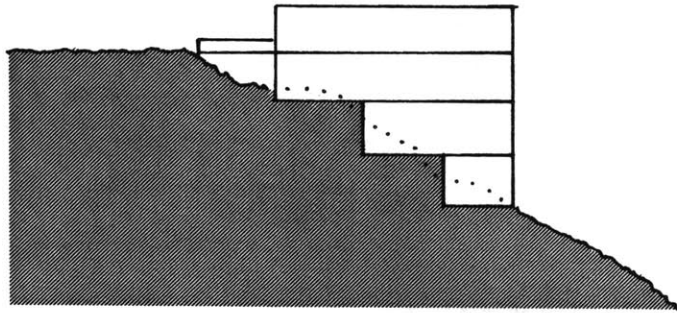

Figure 28. Entry on a single level from uphill.

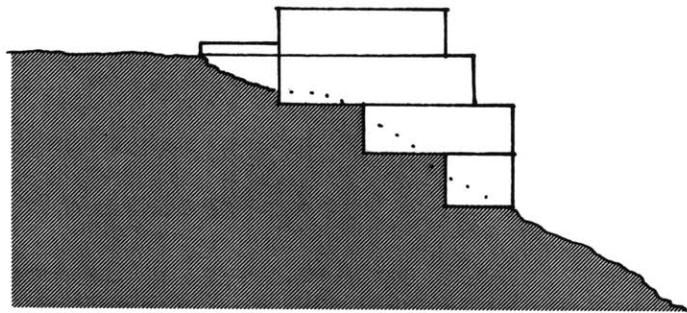

Figure 29. Stepping down mass of house to avoid tall, blank downhill wall.

house open to light. Visually the downhill end of the house may be quite tall against the hill. Stepping the downhill mass of the house down can soften this intrusion. Figure 29.

Stepped sections are intrinsically more sensitive to steeply sloping sites because they respond internally by splitting levels, which reduces the need to change the hill. The use of a split level house means a large reduction in excavation over a pure cut approach such as in the buttress system. Accordingly there is less fill to be hauled off the site, or stabilized on site. The shorter retaining walls are less expensive and easier to engineer than the taller counterfort type of the buttress system. The shallower excavation may also be less disruptive to subsurface water flow.

In general, split and multi-level houses are considered desirable. In fact, they can be found built on completely flat sites. It makes sense to take advantage of the need for multiple levels in the house generated by the sloping nature of the site.

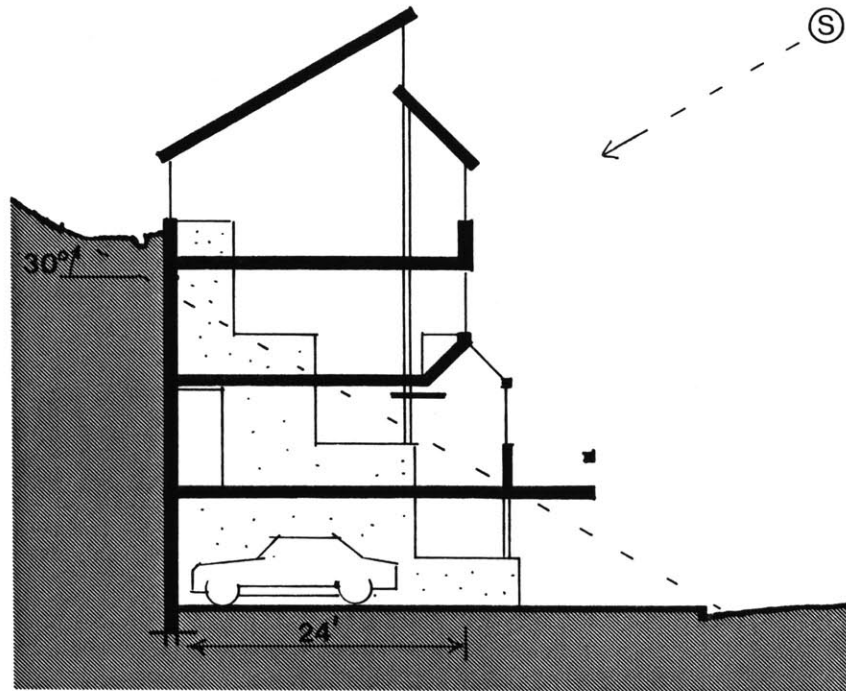

Figure 30. Technique for lighting a single aspect house.

This method consists primarily of making a major cut into the hill and supporting the hill with large counterforts or buttresses. It requires a radical change of the hill and, as the slopes get steeper, a large scale intervention to prevent slope failure.

This system might be necessary if one needed to maximize flat space at the toe of a hill or if one had a building site uphill of the access road. In both these cases, the major motivators for using this system are providing parking, and access to a front door(s) at a distance not too far removed from the street. In most cases the use of this type of system will mean that the front door is at least one flight up from the street.

Lighting the buried edge is always a problem with this system. Figure 30. If one wall with no windows is satisfactory to inhabitants, space planning is simple with this system, and it can be seen as one half of a double loaded corridor apartment building.

The possibility of using the buried edge of the building for light and access exists. A 6' to 8' wide zone separating the building from the hill will provide plenty of room for light wells, elevators, and bathrooms. The resulting spaces, lit indirectly from the side or from above could be quite nice. This system might also be useful for bringing in light on a difficult North facing slope.

The buttress system tends to generate a vertically organized building, resulting in a potentially large number of stairs to

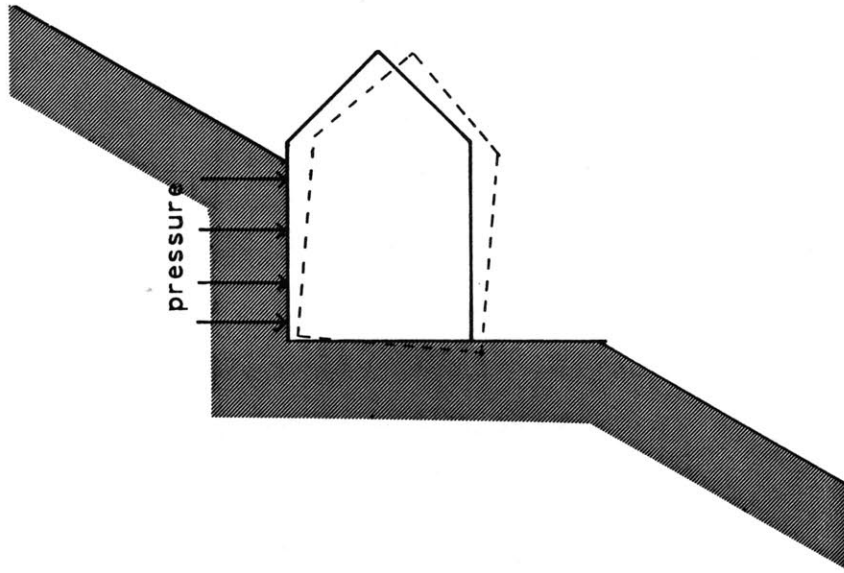

Figure 31. Tendency to pop out of hill due to soil pressure.

reach one's front door. This vertical organization will also generate a tall downhill elevation which may tend to be out of scale with adjacent streets.

Large cutting operations will generate a great deal of soil that may need to be trucked out. Simply spreading, or stockpiling soil on slopes will invariably lead to erosion problems, as well as killing vegetation needed to maintain soil stability. Some municipalities have regulations requiring disposal of cut soils as related to slope steepness.

It may be possible that a structure like this might be popped out of the hill by high soil pressures. Figure 31. The

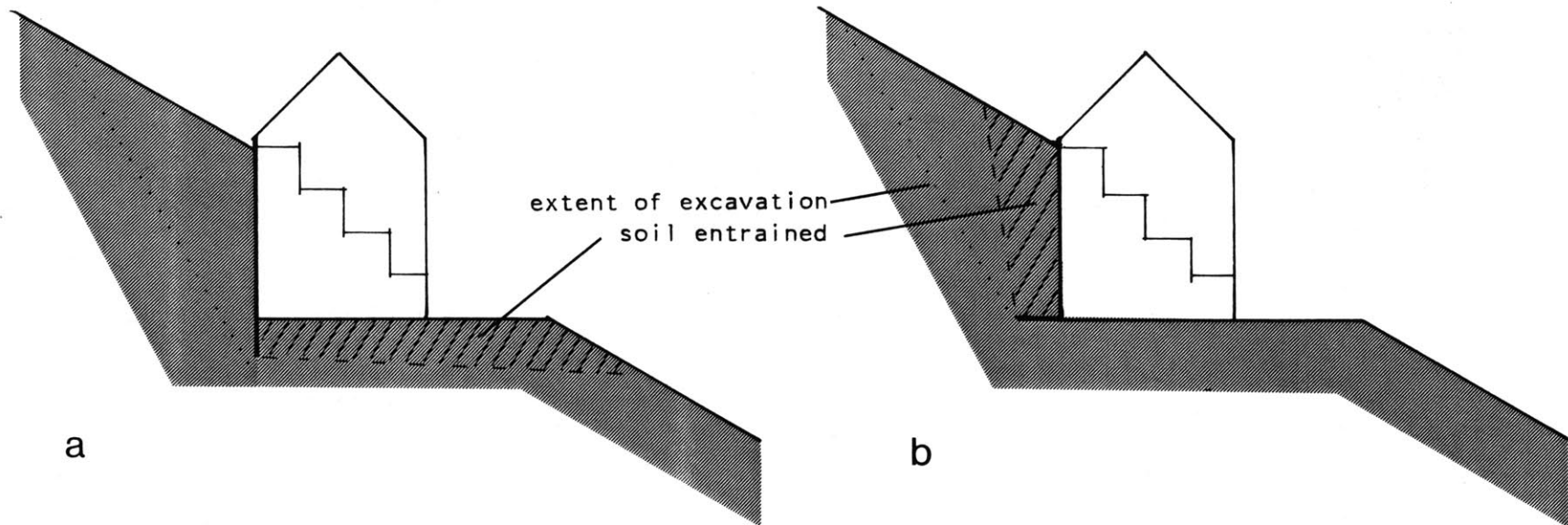
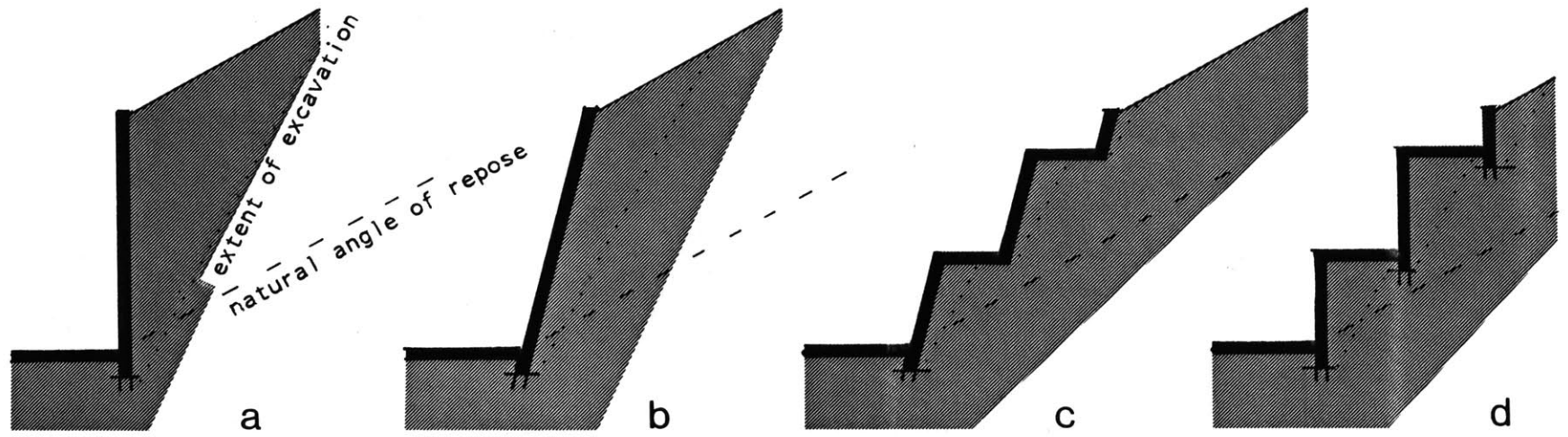

Figure 32. Two possible ways of entraining soil mass to increase foundation stability.

technique might still work if surrounding soil was entrained, made part of the structure, by the foundation somehow.

Figure 32. Two possible techniques are suggested here, but a geotechnical engineer would have to be consulted.



- A.) Vertical wall holds up hill by brute force.
 B.) Inclined wall increases soil angle of repose.

- C.) Stepped, inclined wall reduces pressure further.
 D.) Vertical steps make this a cousin to Terracehousing.

Figure 33. Methods for increasing stability of tall retaining wall.

A modification of the vertical back wall can greatly improve its stability and reduce its cost! (1) In this modification, the back wall leans into the hill. Figure 33b. The behaviour

of a leaning back wall is to increase the angle of repose of the soil, as opposed to simply holding the soil up which is what the vertical back wall does, by dint of brute engineering. Figure 33a. A further modification is to step the tall back wall into the hill which brings the angle of

(1) Suggestion by Waclaw Zalewski

the wall even closer to the angle of repose of the soil. Figures 33c,d.

Architecturally, this sloping back wall provides a space between the back of the building and the face of the hill, providing an opportunity to bring light in. This opportunity is created by separating the tasks of forming a back wall for the building and holding back the hill. The extra space captured can also be used for living, making this a cousin to the Terracehouse. Added advantages of this separation of hill support and closure are that the space can be used to collect seepage from the hill, or as a place to run utilities, sewerage, etc.

It is not clear what the requirements and cost of backfilling and compacting backfill on a buttress project would be. Advantage might be taken of this

backfilling/excavation dilemma to provide level outdoor space uphill of the structure since the soil would have already been greatly disturbed. Figure 34. This uphill area would be quite removed from the street and very private. It would also serve to protect the house from minor landslides on the slope above.

One intriguing aspect of using a buttress system is the opportunity and challenge to make the buttress into an exciting architectural element within the building. It might take on many shapes and could be perforated to a small extent for openings. The buttress would also provide a large amount of thermal mass.

A limiting constraint of a buttress system may be the spacing required between the buttresses. If this spacing is less than 15', it could prove difficult to work

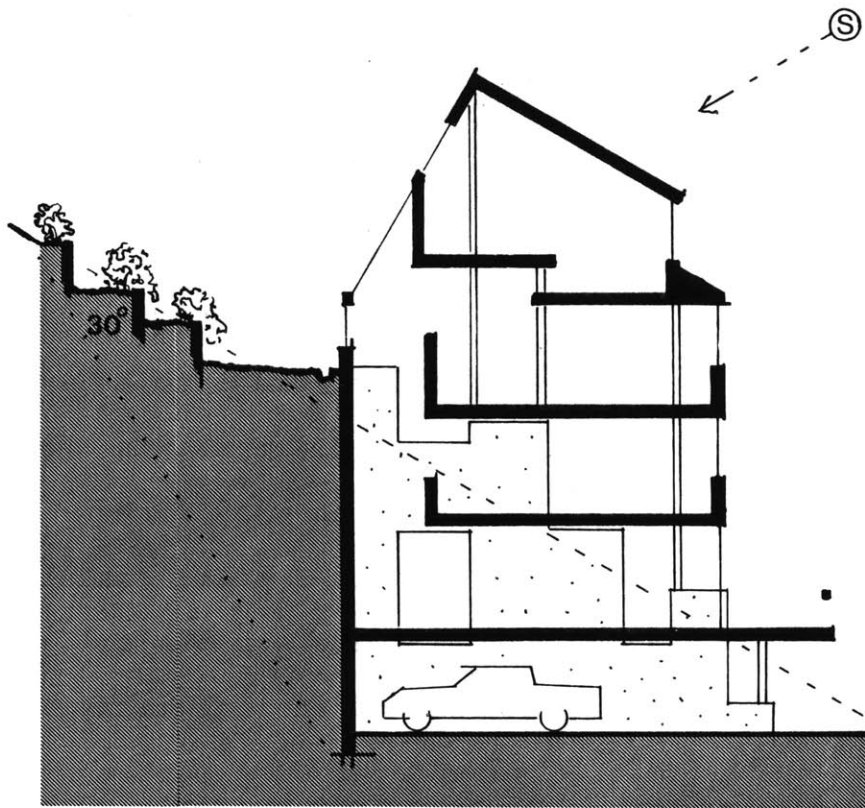

Figure 34. Establishing space uphill of the house on disturbed soil. Buttress can become an exciting architectural element.

with. A system of horizontal ribs will add some design flexibility by increasing the distance between buttresses. The resulting dark 2' to 3' zone could be used for closets, bathrooms, etc. Figure 35. The buttresses should definitely be of fireproof construction.

On shallower slopes, up to about 20° (36%) a cut system can be used to build earth sheltered buildings. Above this slope, second floor windows may become buried, and the energy saving benefits of earth sheltering begin to diminish relative to the value of getting daylight in.

The buttress method has several advantages and disadvantages. Radical changes to the hill are expensive, difficult to build, and the long term, even the short term stability may be

questionable, depending on geology. The process of digging a large hole on some slopes may cause massive undermining, thus construction of buttresses is limited to slopes of perhaps 30° .

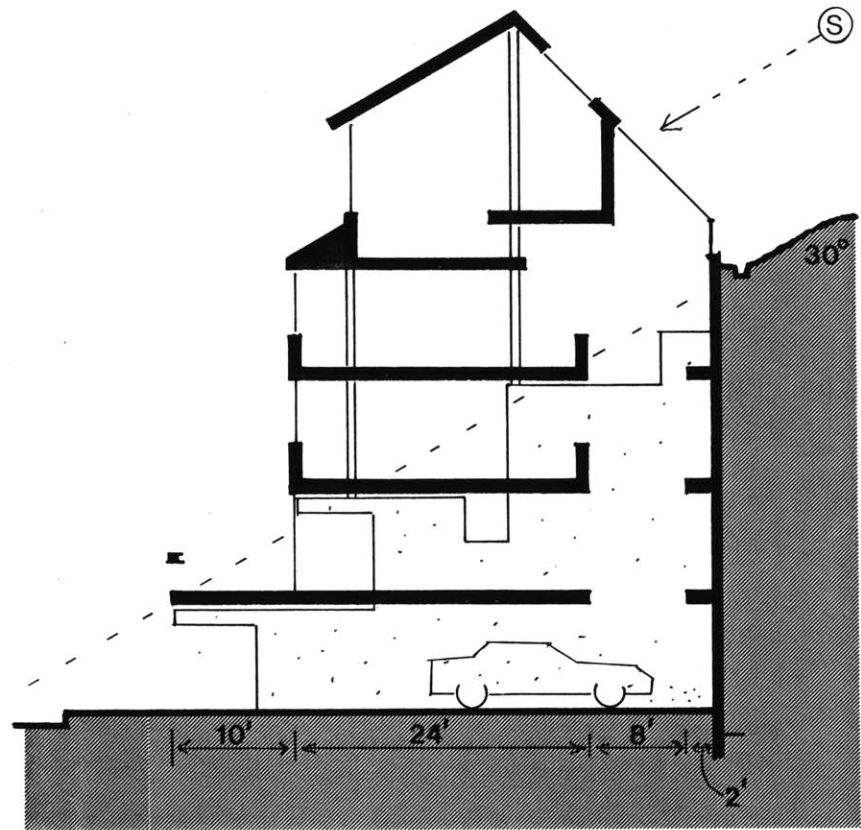

Figure 35. Horizontal ribs increase buttress spacing and provide 2' of storage space. 8' zone for light, access, plumbing.

FILL

This building system consists of hauling in compactible soil, and using it to build up level ground. It is similar to the Pad method previously discussed, except that there is a minimum of cutting into the slope. It is an expensive system due to costs of delivering fill to the site and compacting it. The fill can be left to assume its natural angle of repose or contained with a retaining wall. The use of retaining walls will limit the amount of the hill which is affected. Equally important, the use of the retaining wall will limit the quantity of fill which is required. The cost of the fill is thus reduced while the cost of the retaining wall is added on. To minimize cost shallower fill volumes should be

used.

Generally there must be road access for the large trucks in which the fill is typically delivered. These trucks require a large space for turning around, which may be a limiting constraint on steeper slopes.

This system is rarely used exclusively. It is often used in conjunction with other systems, usually to provide access for automobiles. It is primarily used as part of a cut and fill operation.

On shallower slopes this system might be used to create a building pad whereas on steeper slopes (over 20°) it is more likely to be used as part of a stepped foundation. The value of using this system on slopes steeper than 20° or maybe 30°, is questionable both because of costs

and problems with stability. On flatter slopes this system can be used to raise the elevation of buildings.

A major advantage of this system is that it allows close control of the fill. This may be important for drainage and or soil compactibility. It also has an advantage over a cut and fill system in that there is no need to stockpile large amounts of fill which tend to clutter up the site. This avoids all the problems of erosion control during construction. The vegetation is also saved from being buried under piles of fill.

Another advantage of a fill system is that it may obviate the necessity of bringing heavy equipment out on the slope. The soil can be delivered by crane, chute, or conveyor. Compacting can be done by hand, and concrete can be pumped. This

approach would be quite sensitive to the issue of landscape preservation. On large scale projects it might be quite costly.

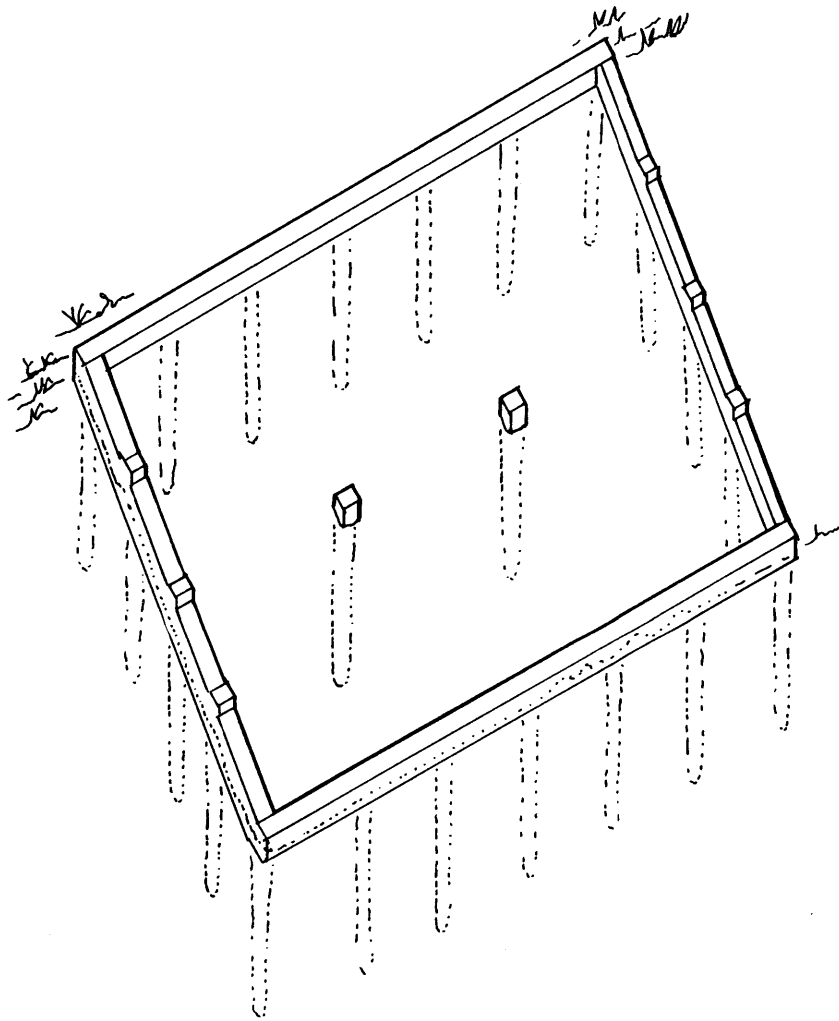

Figure 36. Pier and Grade Beam Foundation

PIER AND GRADE BEAM FOUNDATION □

- "This type of foundation links a poured concrete perimeter footing to the ground with a matrix of grade beams and concrete piers, some up to 20' in depth. The resulting grid grips the hillside like the roots of a giant tree. Slopes in excess of 45° can be built on with this kind of foundation. And in areas where there are landslides, expansive soils or earthquakes, a pier and grade beam foundation may be required by local building code."- Figure 36. (1)

The holes for the piers must be drilled. The process of drilling the pier holes generates a certain amount of fill which may need to be trucked out. On

(1) Michael Spexarth, FHB #16, p.35

steep slopes, the drill rig is tied off (to a tree or perhaps a large stake) at the top of the slope and winched up and down the slope like a yoyo. The rig itself is heavy (often about 12 tons), and tends to squash and shift the first several feet of topsoil downward. One must therefore consider the access route of the drill rig. It is advantageous to keep the drill rig, and any other heavy equipment for that matter, off the site, but this is generally impossible. The drill rig is usually confined mostly to the area which the house will cover. Areas around the house, along with their vegetation, can be left untouched. (1)

(1) Truck mounted drill rigs can operate on slopes up to 30 degrees and do less damage to the slopes than the tractor or crawler mounted auger which can operate on a slope up to 45 degrees.

This type of foundation is not level, but approximates the contours of the hill. A secondary system, such as a stud wall, is often used to make the transition to the horizontal, (not unlike a progressively buried plinth). This system is used commonly in California.

The underlying reasons for using Pier and Grade Beam foundations are that they eliminate most of the costs of cutting and filling, and hauling soil to and from the site. Much of the construction is done by hand, so excessive destruction of the slope caused by excavation equipment is avoided. As discussed earlier, alterations of slopes steeper than 20° to 30° may prove extremely difficult, as well as creating a potentially hazardous situation. For the most part, it is easier to preserve the natural state of

the site.

Pier and Grade Beam foundations can be built on slopes of up to maybe 50° in sturdy soil. (1) Thus they offer great opportunity and flexibility on the more difficult, steeper slopes. The building system does not extend up into the house, and thus imposes few restrictions on the architectural design. The use of a grade beam makes the foundation compatible with a system of bearing walls or point loads over piers. The house can have either a stepped section or through levels.

A system which would work well with a Grade Beam foundation is a series of wooden bents, as used in traditional timber framing. Wooden bents could be

(1)

Estimate based on personal correspondence with M. Spexarth.

made which were taller on the downhill side. They could easily negotiate the change in grade, and merge a traditional, well understood, building system with a new foundation type. Figure 37. The value of adapting an established building system is that the builders already understand it. They will be more comfortable with a new technology if it encompasses something which they are already familiar with.

Downslope sites are less difficult than upslope sites. Spexarth's rule of thumb is that a foundation on a downslope will cost twice as much as a foundation on level ground and an upslope site will cost three times as much. This may be partly due to the fact that building materials are easier to move downhill than uphill.

Both the Pier and Grade Beam

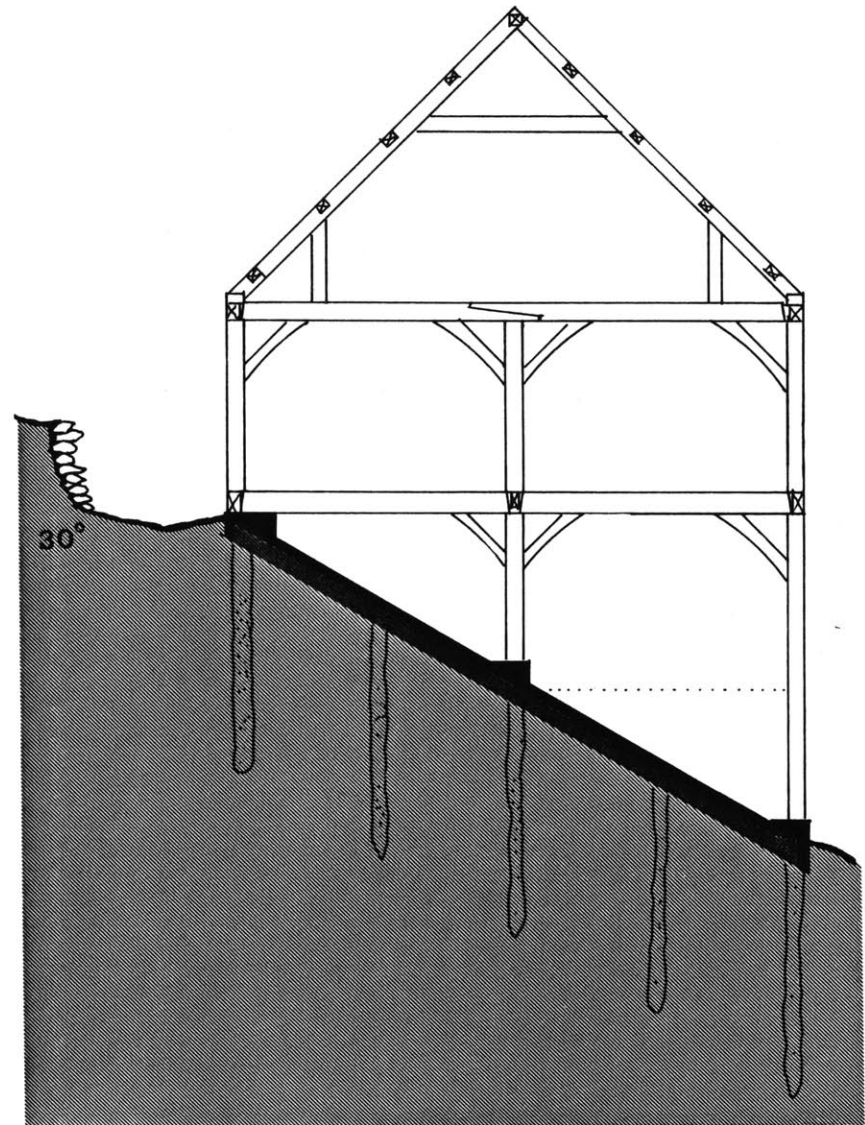

Figure 37. Traditional timber framing would work well with a pier and grade beam foundation.
(Timber frame after Benson, T., F.H.B. #16, p.38, 1983)

foundation and the next to be discussed
Pole foundation system disassociate the
horizontal levels of the living space
unapologetically from the hillside. This
behaviour inherently has less of an impact
on the hillside.

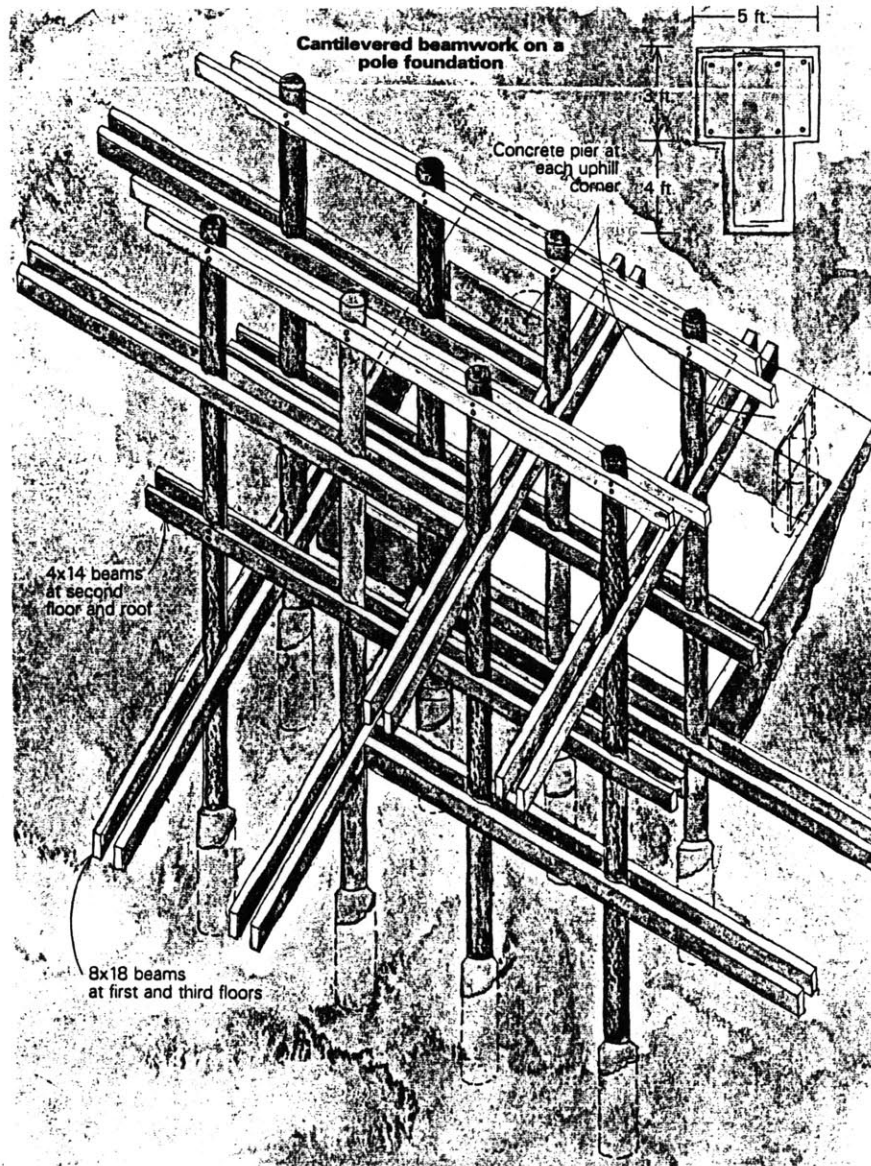

Figure 38. Pole structure
(Arch: Charles Miller, F.H.B. #15,
p.29, 1983)



This building system consists of a grid of poles set directly in the ground. The poles are set in a manner similar to the one used in setting telephone poles. Figure 38. The living space is then suspended from this artificial forest. Poles offer great flexibility for building on hills. They can negotiate slopes at least as steep as 45° (10 in 10). The steepness of the slope which can be built upon is a function of the pole length and the buckling strength of tall poles. The steeper the slope, the taller the poles. Poles can be obtained in excess of 100' in length.

There is much freedom in both the horizontal and vertical dimensions, thus making the system very Corbusian in

nature. The plans and the sections can be very free from the structure. The freeform and whimsical designs which can be constructed using this system attest to this flexibility. Figure 39. Using poles, a horizontal platform can be easily established, relatively independent of slope steepness or contour irregularities. The elevations of the floor levels can be adjusted, simply by attaching the crossbeams higher or lower. A large number of different levels are possible. Cantilevering the main crossbeams provides low cost options for more living space and/or outdoor decks.

The walls are not load bearing in this system, so some shear resistance must be built in to resist wind loads. (1) The

(1) Fine Homebuilding #15, p.32-33, 1983.

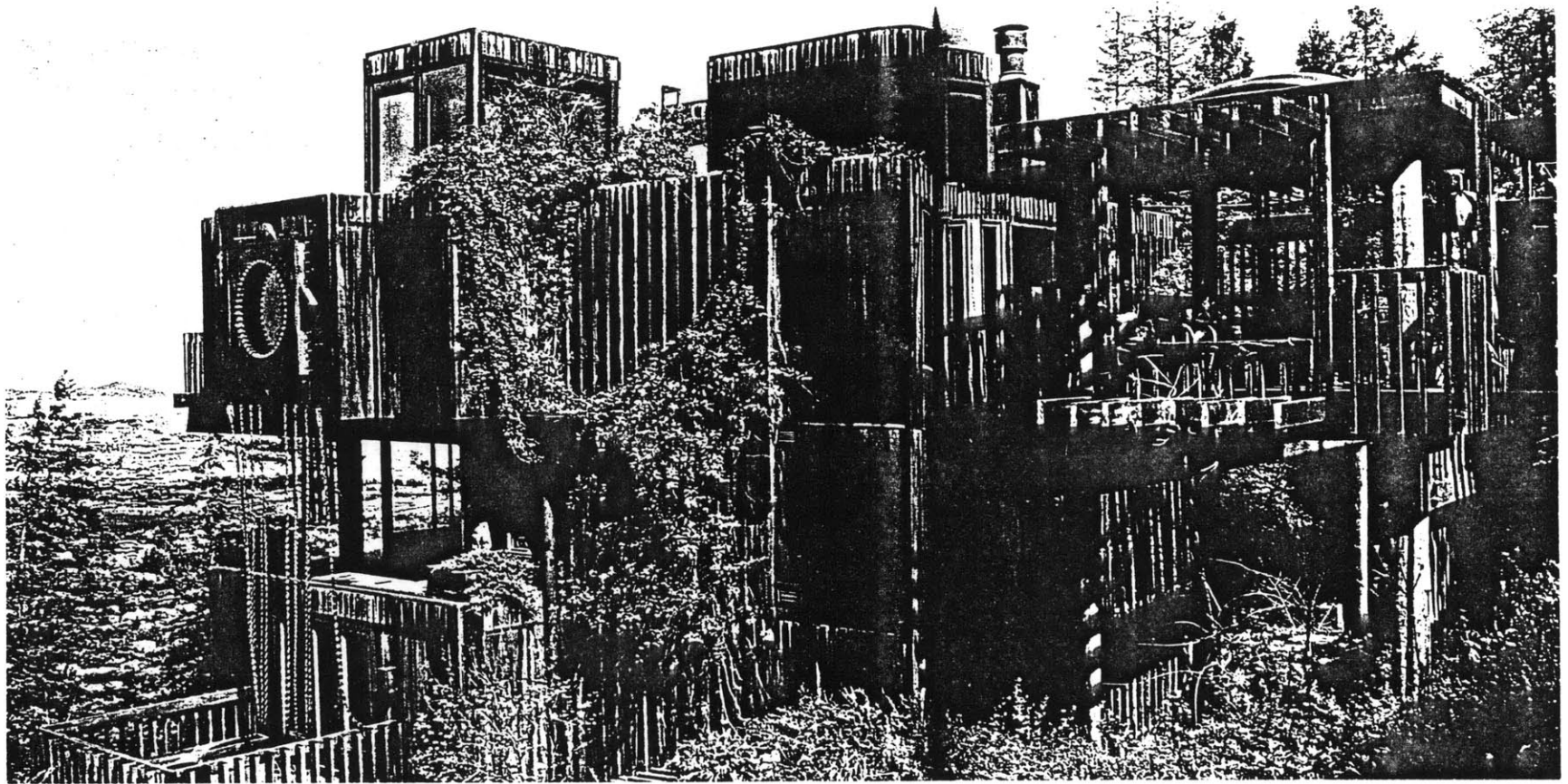

Figure 39. Pole foundations enable freeform design.
(Arch: Charles Miller, F.H.B. #15,
p.26-7, 1983)

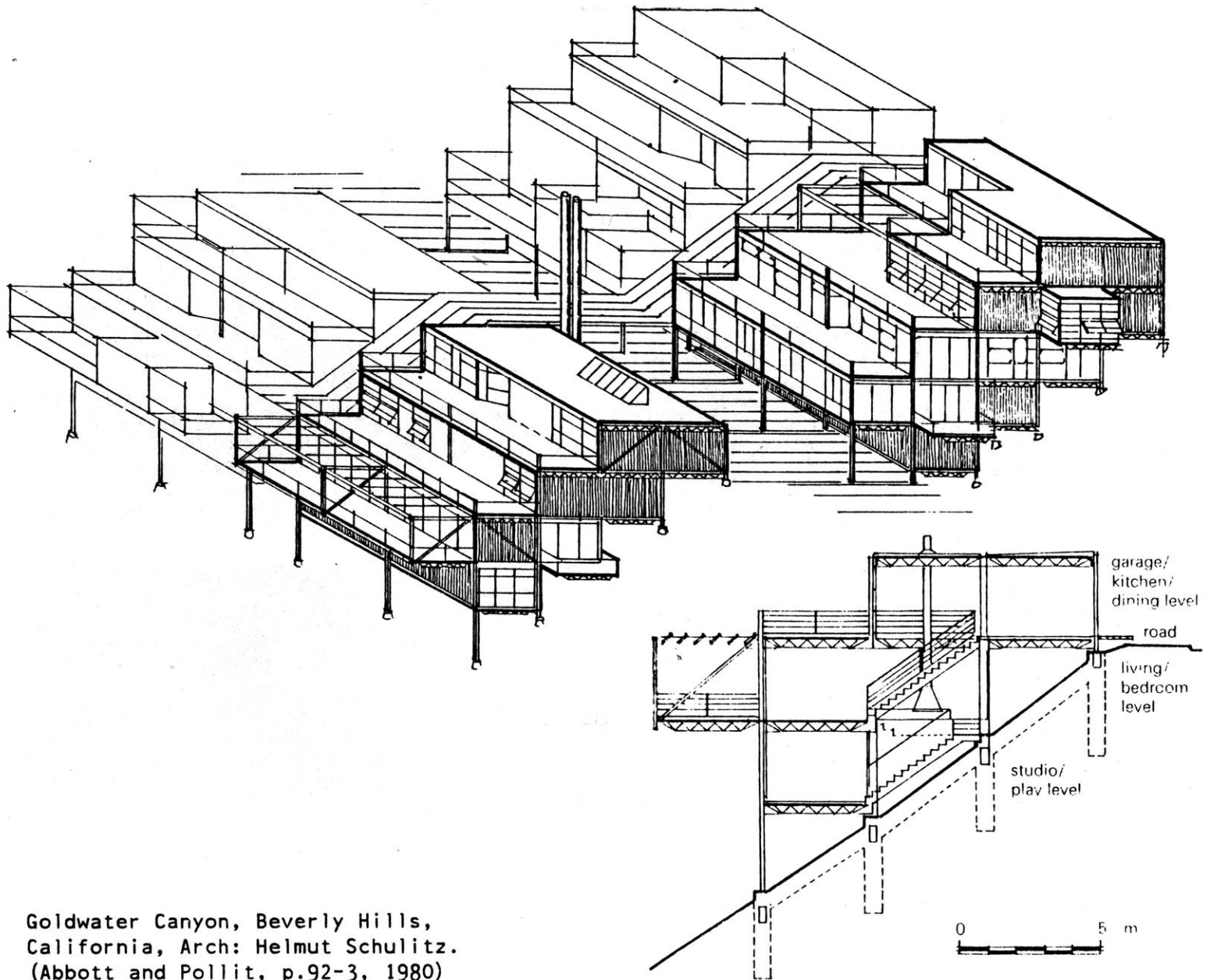

Figure 40. Goldwater Canyon, Beverly Hills, California, Arch: Helmut Schulitz. (Abbott and Pollit, p.92-3, 1980)

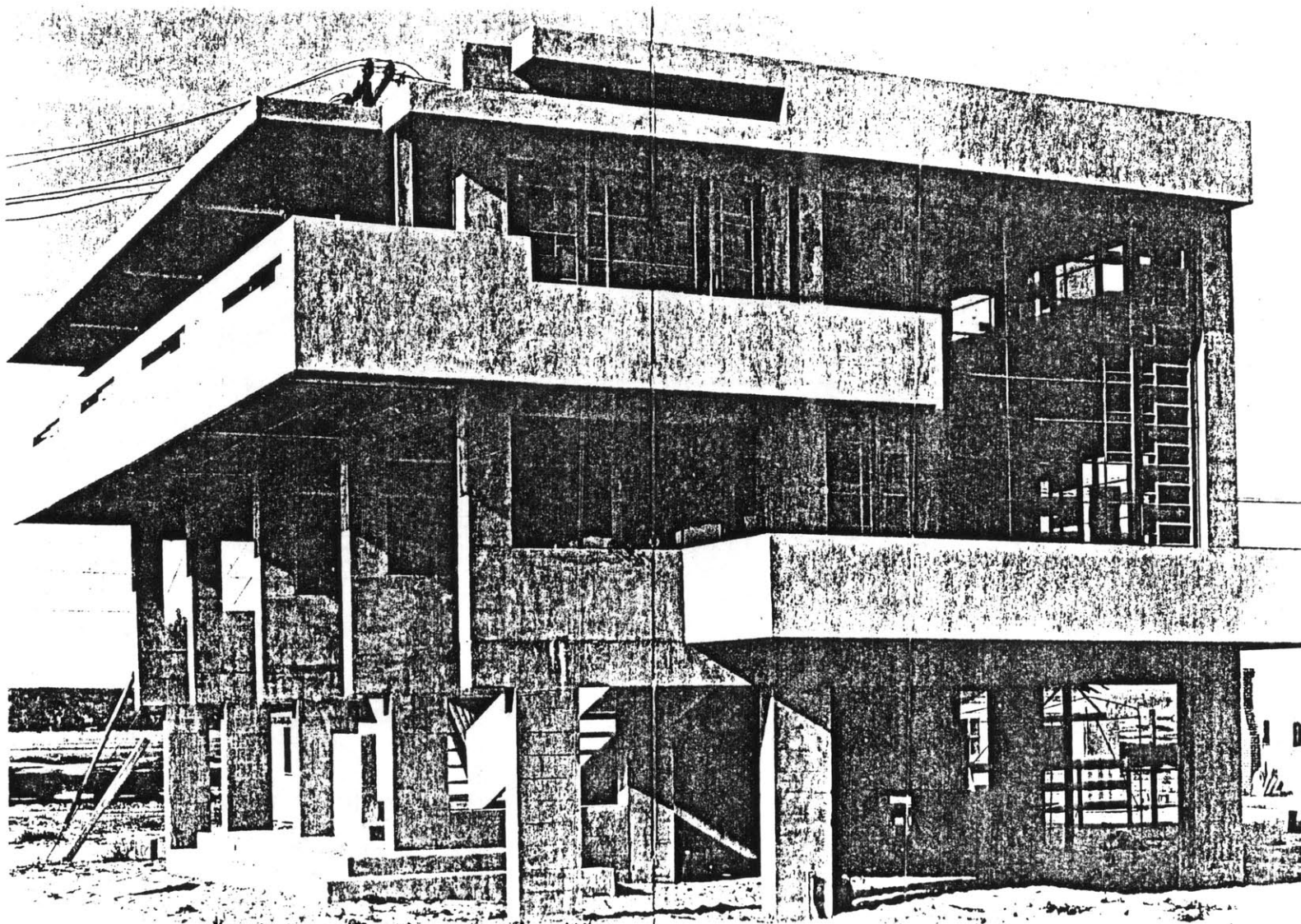

Figure 41. Concrete frames can easily negotiate grade changes. Beach house for Dr. P. Lovell. Newport Beach, 1925-6, Arch: R.M. Schindler (Gebhard, p.84-85, 1972)

embedded poles may provide quite a bit of wind resistance, but possibly not enough to avoid uncomfortable sway. (1)

A three dimensional design grid can be used to design pole structures. This Goldwater Canyon housing project shows the possibilities of such a grid and it's compatibility with prefabricated construction. Figure 40. Note that this structure is actually a hybrid of Pier and Grade Beam below ground, with a pole structure above.

A poured concrete pole structure might easily grow into a series of concrete bents or frames, among which floor levels would be supported.

Schindler's Beach House for Dr. Phillip

(1)

For a more complete discussion of pole building the reader is referred to Merrilees, 1980.

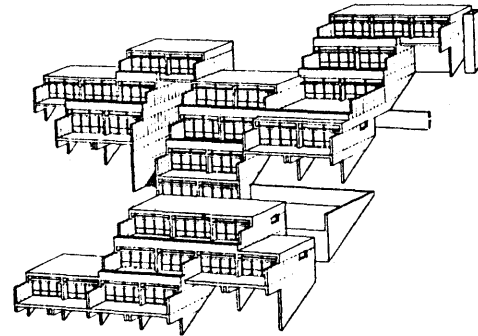

Figure 42. Bulkheads support housing
Arch: Erwin Muhlestein, Switzerland
(Riccabona, p.39, 1972)

Lovell illustrates this possibility in a situation where the building needed to be off the ground because of it's location. Figure 41. There is good potential here for use on hills. This system would also work with a grade beam foundation. If the concrete frames were solid, they would behave like bulwarks, giving shear resistance to brace structures on the hill. Bulwarks would require excavation and perhaps conventional footings. Figure 42 shows them in a housing application.



Figure 43. Bulkhead house
Arch.s: Nees, Beutler, Gyax, Basel,
Switzerland.
(Wolff, p.65, 1965)

Figure 43 shows them used to prop up a house. Bulkhead walls are oriented transverse to the contours causing a minimal change to drainage patterns.

The possibilities which arise out of mixing trusses or box beams with pole foundations are endless and intriguing. Where the cantilevered beam can add 8' of extra space, the cantilevered truss can add a hair-raising 20'! The ease with which cantilevers can be added to pole structures makes the provision of private open space straightforward.

A pole foundation is probably the least expensive method for steeper hillside applications, although it still costs more than a conventional foundation built on level ground. (1) Some sources

(1) Hillside Homes, p.11, 1961.

report that pole structures built on level ground can be much cheaper than conventional buildings. This may not hold true for up to code residential buildings.

It is also possible to use pole foundations in a systematic way at higher densities. Poles come in a variety of types including concrete and steel, but wood is by far the most common. Poles can be set on piers, poured in place with concrete, set on footings placed below ground, or set directly in the ground. (When using wooden poles precautions must be taken to discourage rot.) Another advantage of a pole foundation is that it is mechanically flexible, and thus can accommodate limited settling. It is quite possible that a pole foundation can be designed to allow for vertical adjustment, should settling prove to be too uneven.

The problem of rotting with wooden poles, is a major disadvantage of this system. Treatments available can increase lifespans of directly embedded poles to perhaps 80 years. Research is constantly going on due to the popularity of this system in many areas. The difficulties involved with replacing a rotted pole in the confined space of an under house crawlspace have yet to be fully explored. There may be a distinct long term advantage in using a more permanent material such as concrete below grade, and switching to the cheaper and more workable wood above grade. Miller (1983) recommends keeping the poles inside the house to protect connections and wood from water damage.

The progression from public to private spaces may be upside down in pole

structures downhill of the access. One can enter a living space on the top floor, and find the bedrooms to be downstairs, rather than upstairs.

The internal flexibility of a pole system, along with its' disassociation from the slope, make it very responsive to the specific issues of building housing on slopes. By its nature freestanding, the problems of lighting a buried uphill wall are less likely to occur, especially if the house is separated from the parking structure. Methods of access to free standing structures on slopes include bridges, stairs, ramps, or paths.

Since horizontal access is desirable, a downhill pole house, connected by bridge to the parking area makes good sense. It can become a "built promonotory" if it is of large size, running transverse to the

contours. (1)

The bridge can be used at an angle to negotiate some level change, allowing direct entry into upper living spaces, as well as leaving green space to serve as a buffer between the street and the house. This space can be developed as a garden. Figure 44. The pedestal house in Portland, Oregon is a rare case of a bridge being used structurally to brace a pole building to the hill. Figure 50s. This house is extremely disassociated from the hill. It is possible that the driven piles on which it is supported were driven by a crane suspended pile driver, thus keeping all major equipment off the steep and fragile part of the hill.

The characteristic of a pole structure to stand off of the hill makes

(1) See Giamportone, and Zalewski

it more compatible with being built downhill of the access road, especially on sites steeper than 20' (44%). The setback and parking access requirements of uphill sites create deep cuts which are contrary to the nature of a pole system. A pole system set on top of a full concrete foundation would be of questionable value since standard framing techniques would be possible, and probably cheaper.

Separating the parking from the house frees up the problem of building on a steep slope because the car is constrained to the access road, whereas the house may be better off away from it. Figure 45. This separation of elements helps avoid a need for large horizontal cuts in the slope which quickly become difficult, dangerous, and expensive as their size increases. Freed from the car, the house

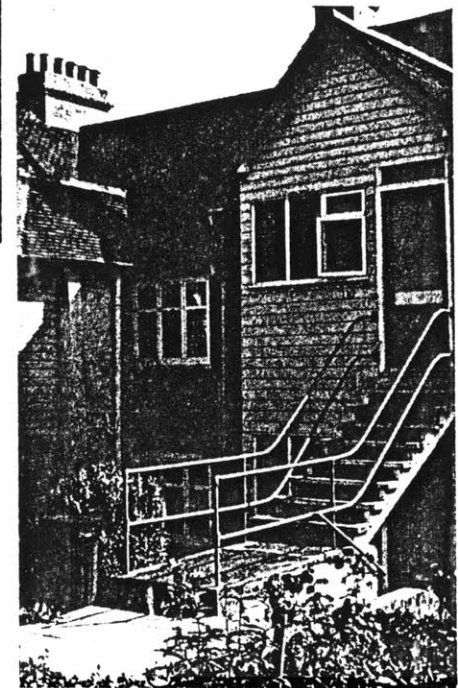
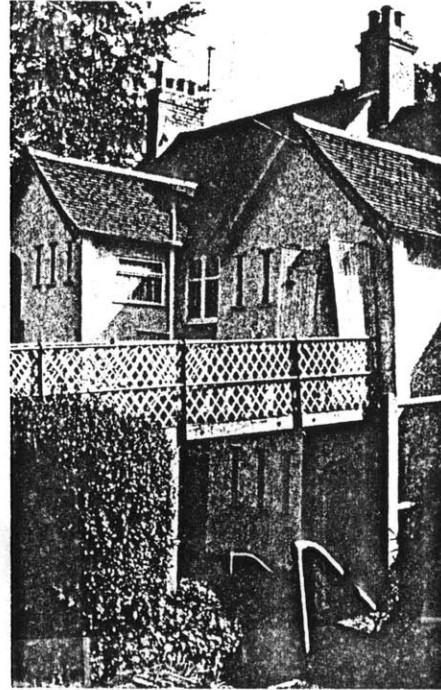

Figure 44. Bridges negotiate level changes to downhill houses, leaving room for gardens. (Simson and Purdy, p.104, 1984)

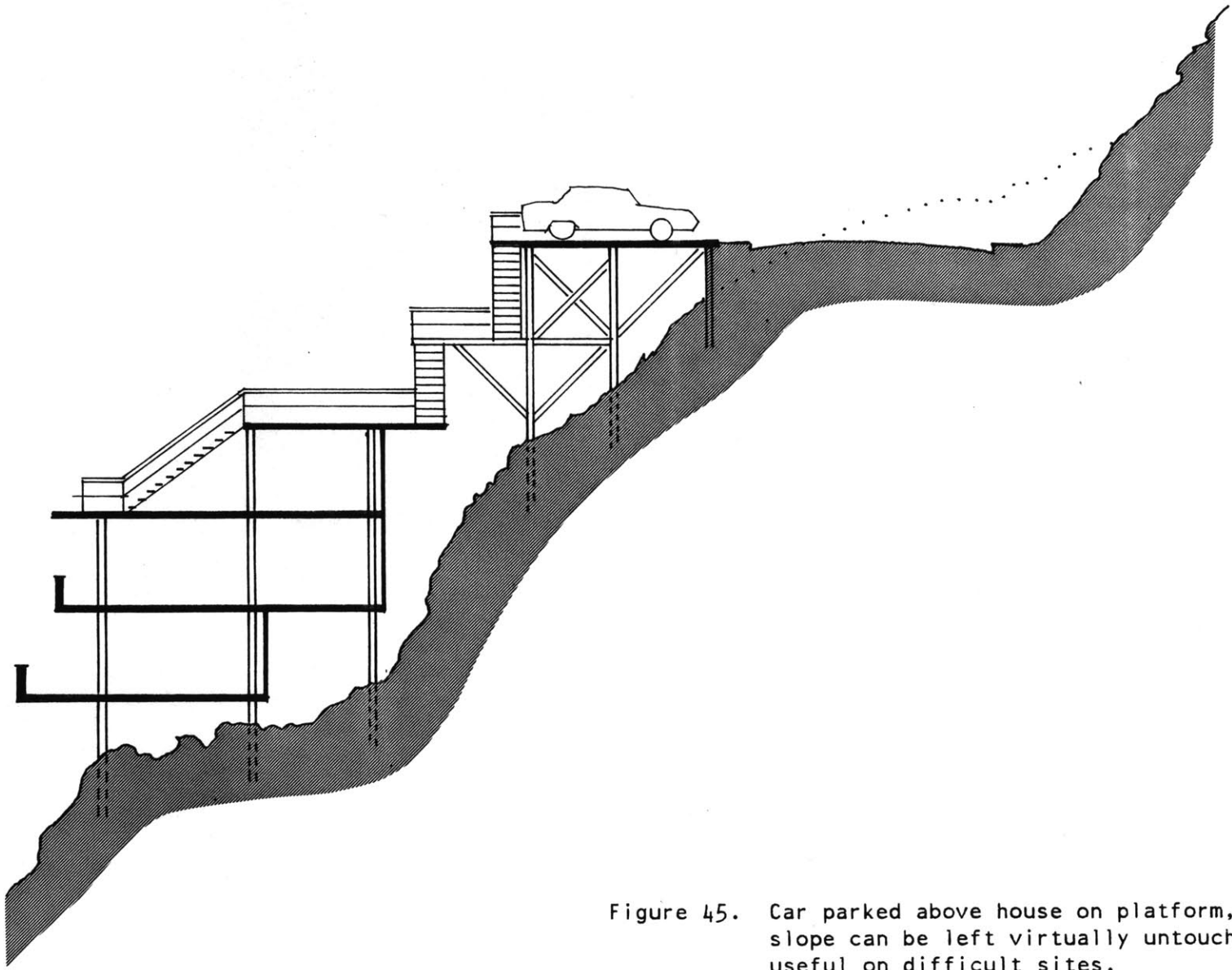

Figure 45. Car parked above house on platform, slope can be left virtually untouched, useful on difficult sites.

can move down the slope to a more suitable location. This possibility would be very useful on a very difficult slope. The disadvantage of moving the house off downhill of the access is that it generates the problem of lugging groceries down to the house and garbage up to the street. Sewage must be pumped, or discharged downhill. An uphill house can also be separated from the parking.

Figure 66.

Disassociation from the ground also means these structures can be used where the ground is difficult to attach to, due not only to steepness, but also to irregular profiles, wetness, marshiness, or fragility. Pole structures are built all along the East Coast of the U.S. Built on sand dunes, they allow movement of the sand. Built over water, they allow

for tidal changes in water level. Built in flood plains, they provide protection from disaster. They are even used in the antarctic to prevent melting of the permafrost.

The disassociation of the structure from the ground means the pole structure

will have a minimal effect on the landscape. Pole structures can be built on top of a site and barely affect the vegetation. Under this Japanese teahouse, poles are used to build over and preserve a special and difficult to build on area. Figure 46. Needless to say, existing drainage patterns will be minimally affected. The silhouette of a pole structure can have great variation, becoming an interesting addition to the hillscape, instead of an intrusive block.



Figure 46. Section of Kinkakuji teahouse, early seventeenth century. (Bring and Wayemburgh,, p.36, 1981)

HYBRIDS

Many building sites will suggest a hybrid solution composed of two or more of the systems described above. For example an excavation might be made for a basement/mechanical room poured with concrete, which would then serve as an anchor for a pole structure further downhill. A parking area uphill of the basement might be established using the fill removed from the basement excavation. This system makes sense because poles, which can easily negotiate grade changes are used downhill, while the digging is confined to an area closer to the road accessible to big equipment. The variations are endless and are a result of the decision maker(s) use of common sense, as well as respect for the land.

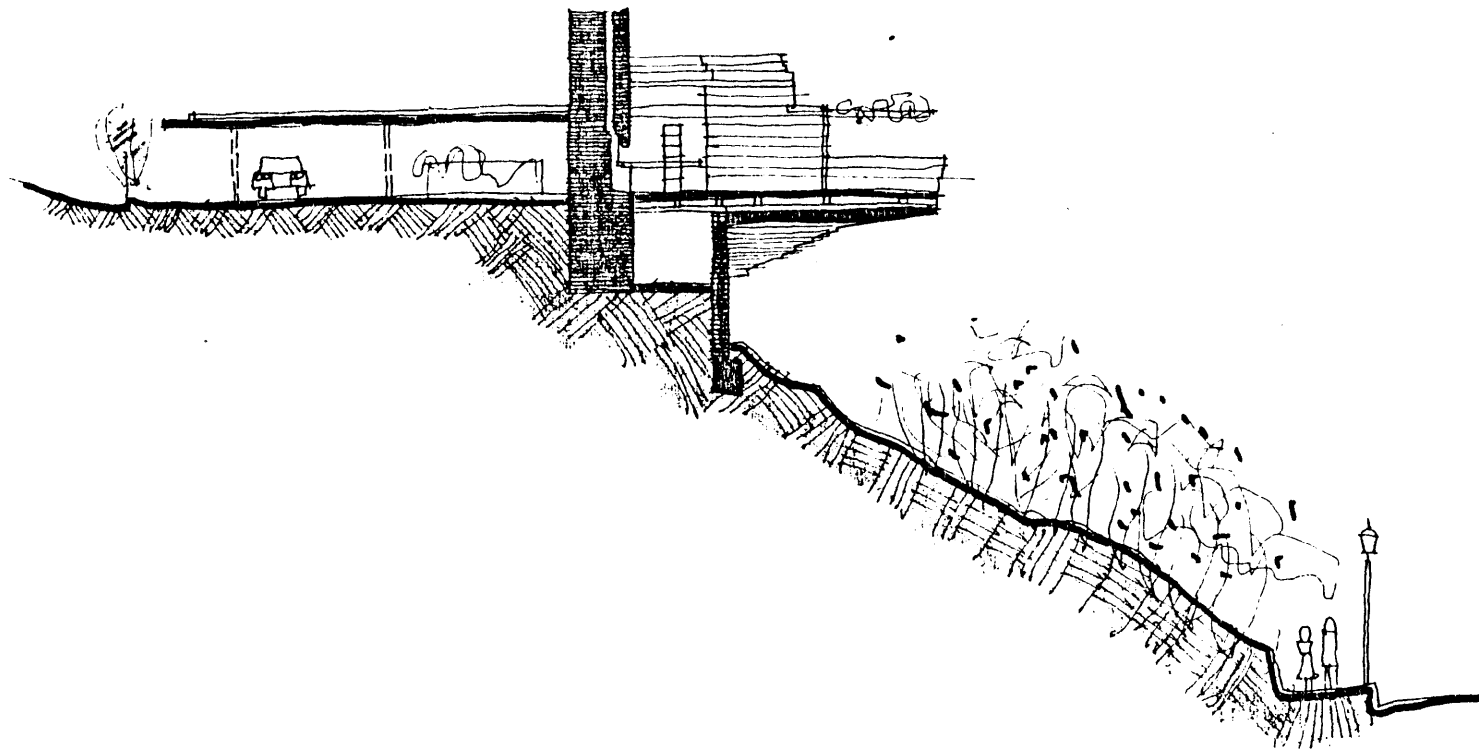

Figure 47. Sturges House by Frank Lloyd Wright,
saves flat land for access and yard.
Brentwood Heights, California
(Abbott and Pollit, p.94, 1980)

CANTILEVERS



The cantilever is another important option in building on steep slopes, primarily because it needs nothing underneath it. It is easily used for small subsidiary spaces such as porches, or baywindows. Cantilevering with reinforced concrete or trusses extends this option to house size moves. Figure 47. Wright's Sturges house is built on the rim of the hill, leaving flat space for yards and parking. These wooden structures of Cuenca, Spain illustrate a smaller size cantilever with a much larger drop below! This building is really grabbing for space. Figure 48. The potentials of cantilevering trusses can also spark the imagination. Figure 49.

These cantilevered homes and rim

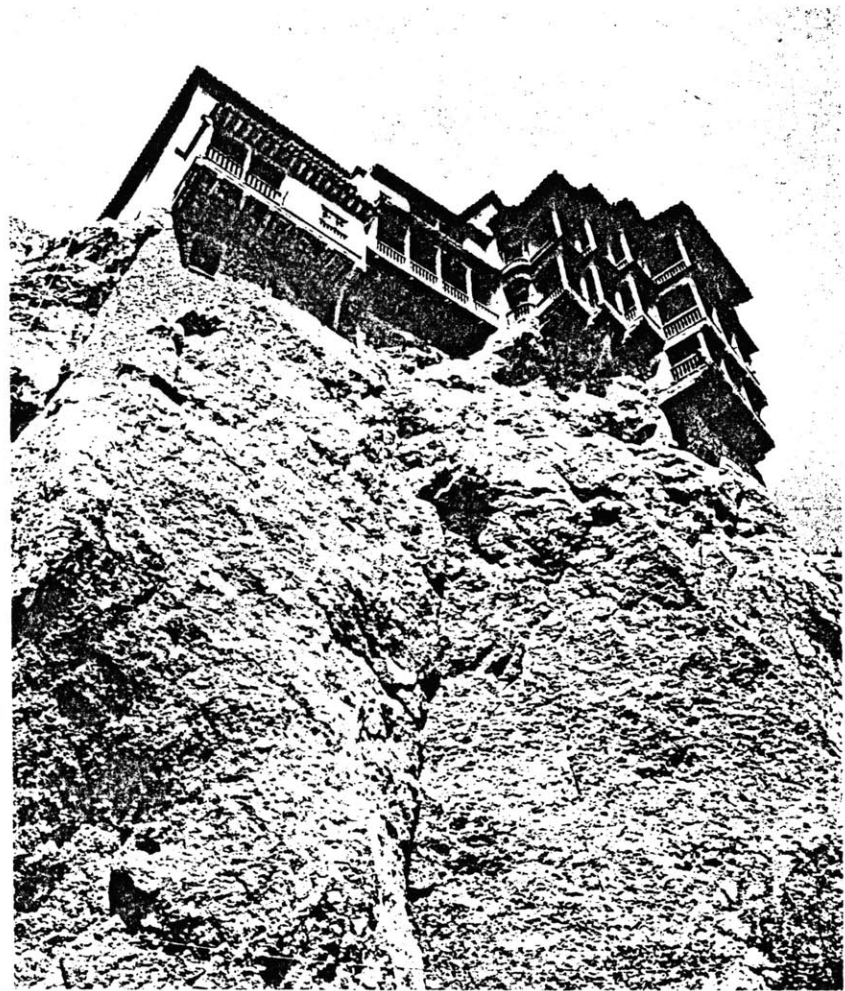
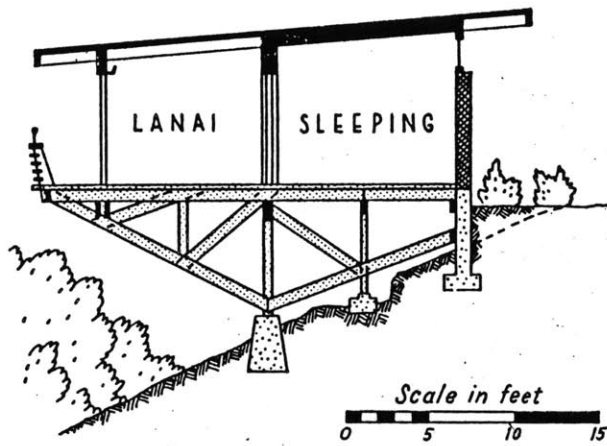
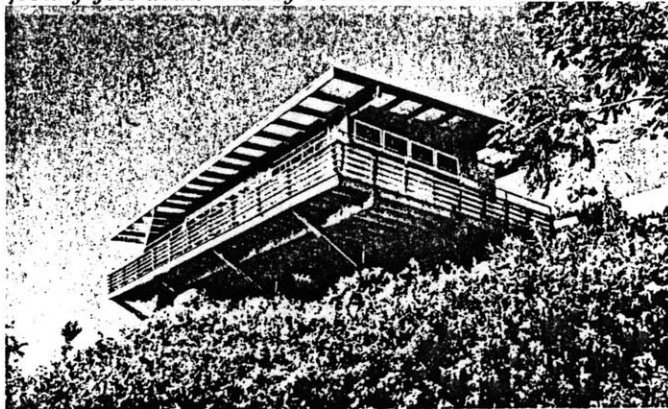

Figure 48. Cantilevered timber structure from Cuenca, Spain.
(Carver, p.76, 1981)



Inverted rough lumber truss supports the house shown in photos at left. Heavy concrete foundation on street side goes down 4 feet. Second foundation footing goes down under peak of truss. Third footing goes down midway between other two.



Honolulu house showing bridge-like underpinnings. Drop of 17 feet from deck edge, now masked by landscaping, appears much less.

Figure 49. Cantilevered wooden truss postures precipitously on this hillside.
Arch: Alfred Preiss, Honolulu
(Sunset Ideas for Hillside Homes, p.53, 1961)

houses call a great deal of attention to themselves, vying with the trees for views and light. They make a statement of being bold enough to, and enjoying, living up in the air.

BUILT EXAMPLES

A range of buildings are presented in figure 50. They are organized from left to right by increasing inclination. Buildings disassociated from the ground are toward the top of the page, while buildings cut into the ground are along the bottom of the page. Some patterns can be seen emerging from this array. Though many of these examples are houses, the patterns of building are similiar to housing.

At 10° a pole type foundation, actually concrete piers, (Figure 50a) is used only on difficult sites, in this case a marshy one. A stepping house can be used transverse to the contours. Figure 50b. Buried edges are already becoming a problem. Figure 50c.

At 15° buildings are beginning to disassociate from the ground. Figure 50e is a pole structure used to bridge over a steep part of an Oregon resort condominium. Figure 50f is a large, expensive, cut-in intervention accessed from uphill.

By 20° almost all buildings are propped off the ground in some way, and one sees the Terracehousing type beginning to be used. Figure 50k. The transverse stepping technique is still in use until about 25°, when stepping by floors becomes practical. Figures 50g,i.

At 30°, pole structures (figures 50l,m), grade beams (figure 50o), and cantilevered trusses (figure 50n) take over. The cut and terraced house in figure 50k is built on solid rock. It is reminiscent of the Spanish and Italian

DISASSOCIATED FROM GROUND

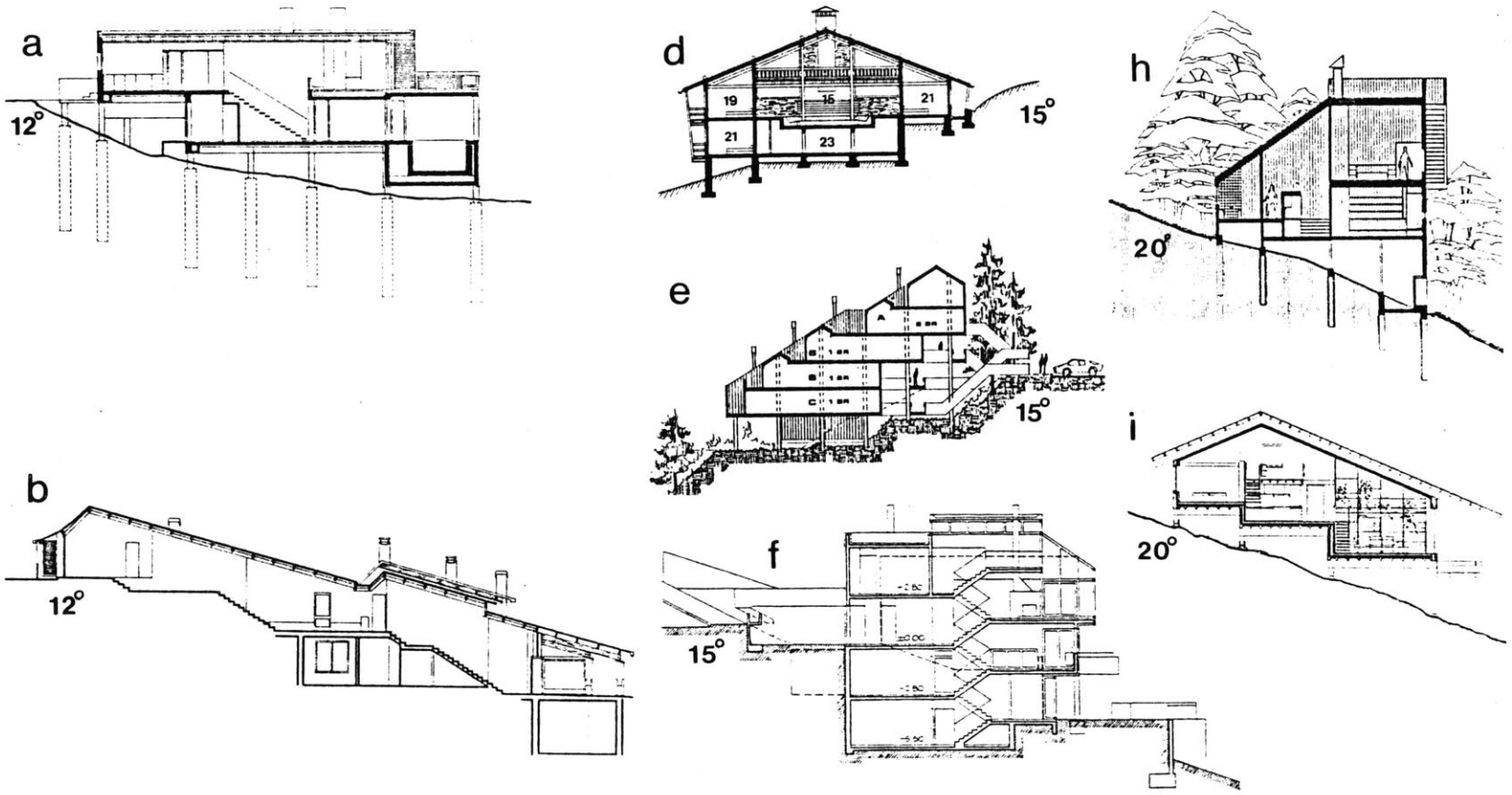

BUILT INTO GROUND

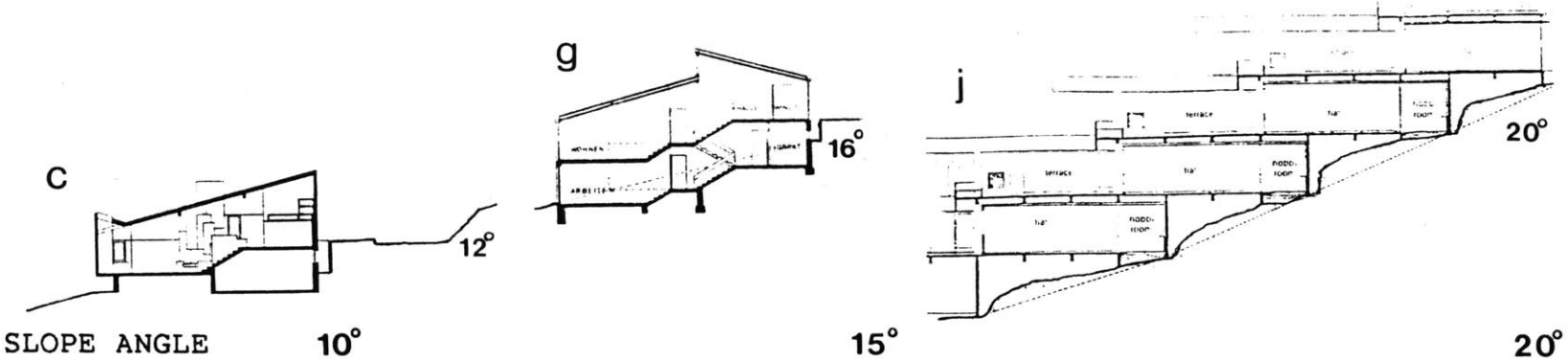

SLOPE ANGLE 10° 15° 20°

Figure 50. PATTERNS IN BUILT EXAMPLES

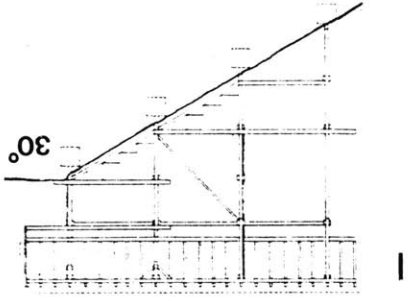
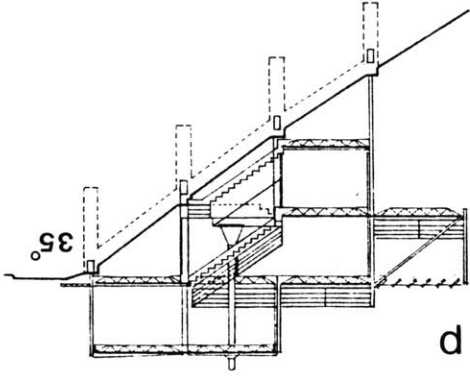
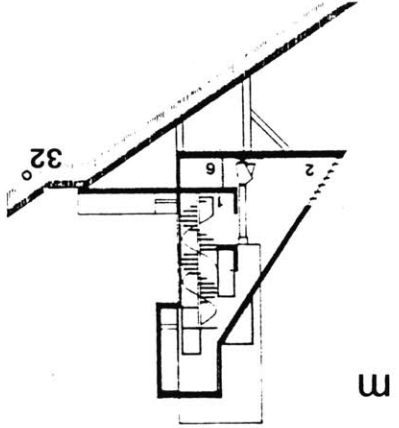
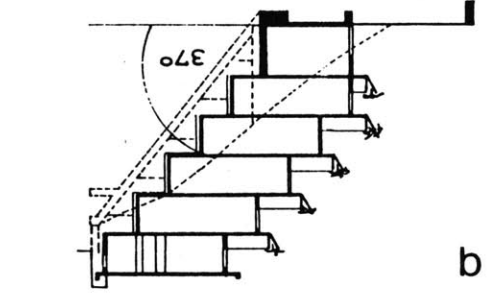
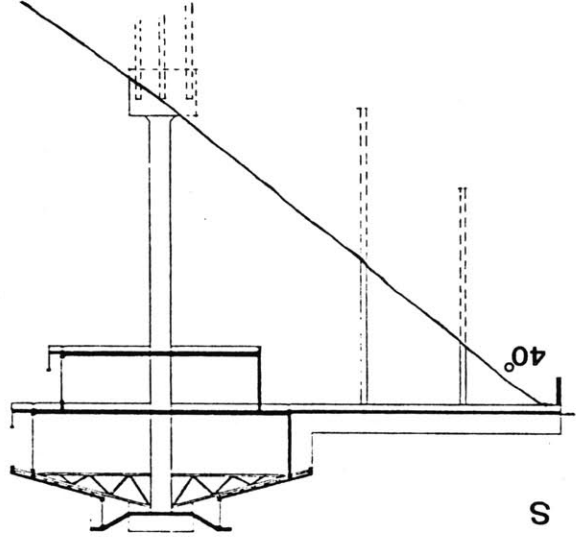
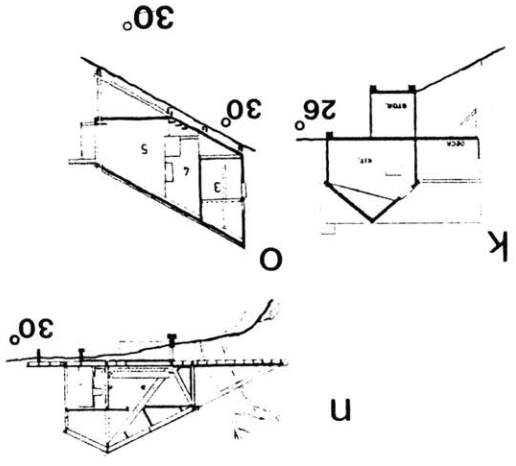
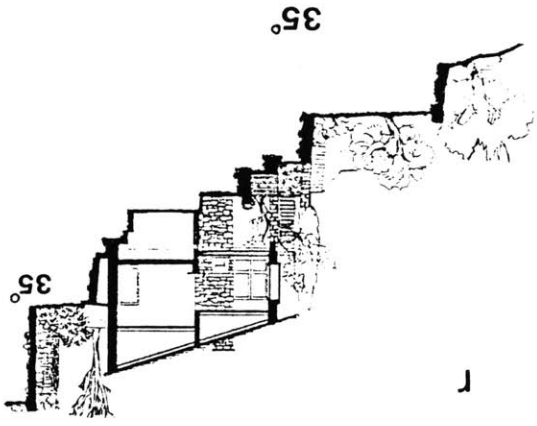
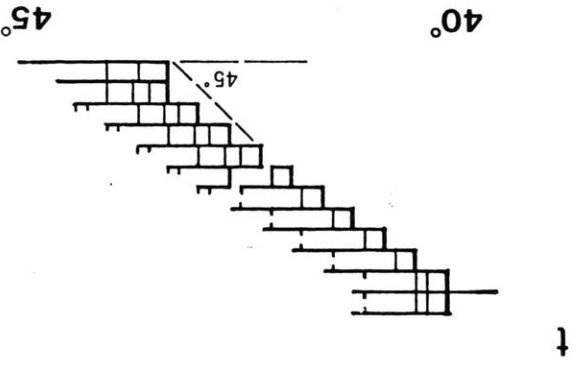

rock based hilltowns.

Generally only pole structures, grade beams, and Terracehousing can be used at 35°.

At 40° to 45°, Terracehousing is practically the only workable housing type, and rapidly becomes a large scale , building sized intervention. Pole structures and grade beams can still be used but with difficulty. The pedestal house is the "uppermost" expression of a pole foundation.

References for Figure 50

SOURCE	ARCHITECT / DESIGNER, LOCATION
a. Wolff, p.52	Franz Kiessling, Starnberg, Switzerland
b. Wolff, p.87	Roberto Menghi, Comersee, Italy
c. Wolff, p.67	W. Aebli and B. Hoesli, Walensee, Switzerland
d. Wolgensinger, p.14	Christian Durupt, Meribel-Les-Allues, France
e. Abbott and Pollit, p.166	Campbell, Yost, Grube and Partners, Oregon
f. Wolff, p.71	Peter Walser, Stuttgart, Germany
g. Wolff, p.78	Kurt Gelhaar and D. Hoor, Hamburg, Germany
h. Wolff, p.63	McCue Boone Tomsick, San Francisco, Cal.
i. Wolff, p.102	Lothar Gutz and Partner, Heidleberg, Germany
j. Abbott and Pollit, p.142	Dag Rognlien, Oslo, Norway
k. Wolff, p.53	The Design Company, Mill Valley, Cal.
l. Wolff, p.23	Manfred Kovatsch, Karnten, Italy
m. Wolff, p.110	Arley Rinehart, Denver, Colorado
n. Wolff, p.46	Wendell H. Lovett, Washington
o. Wolff, p.105	Carl Fahr, Bodensee, Germany
p. Abbott and Pollit, p.93	Helmut C. Schultz, Beverly Hills, Cal.
q. Riccabona, et.al. p.17	Fritz Stucky and R. Meuli, Zug, Switzzterland
r. Wolff, p.19	Renato Baldi, Sienna, Italy
s. Wolff, p.75	Zaik, Miller, Butler, Portland, Oregon
t. Riccabona, et.al. p.25	Anne-Tinne Friss and Mogens Friss, Norway

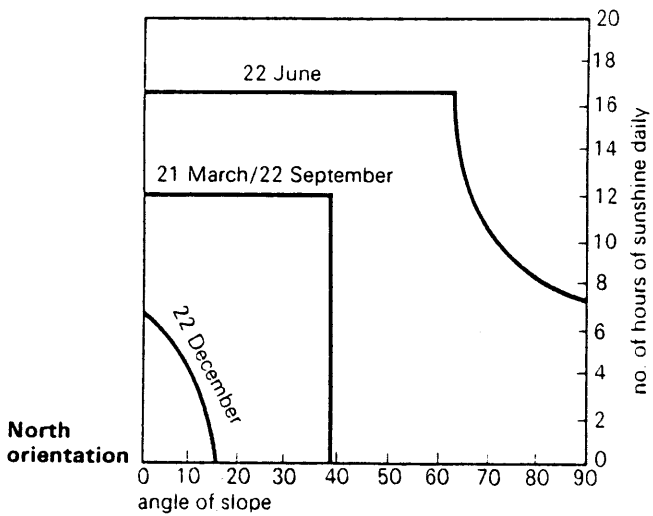
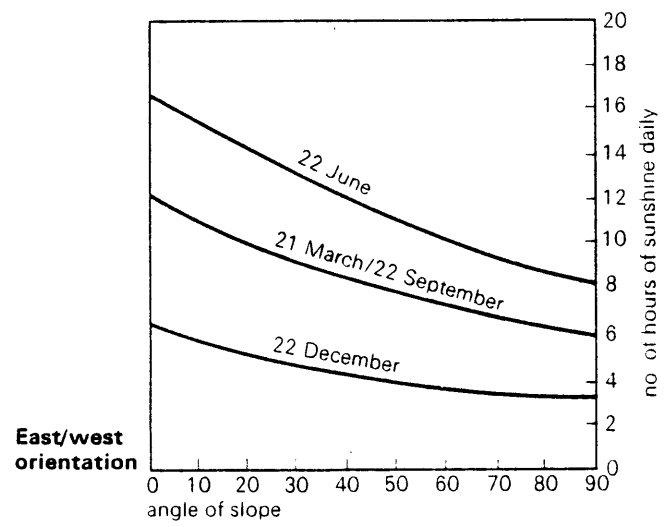
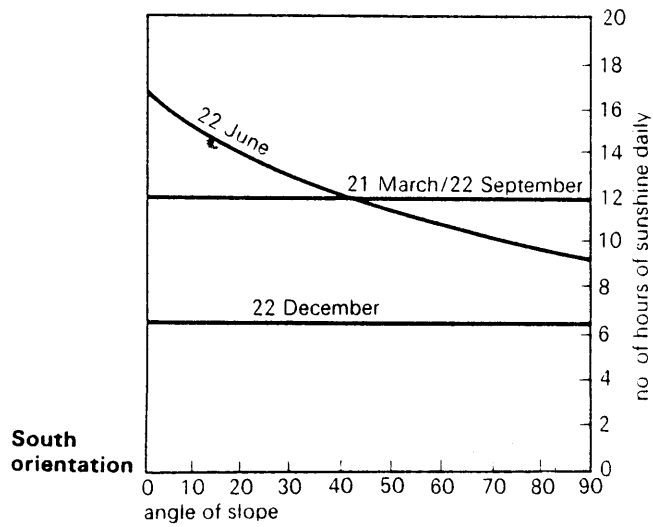

Figure 51. Slope Orientation v.s. Number of Hours of Sunshine Daily (Abbott and Pollit, p.219, 1980)

HOUSING ISSUES

LIGHT AND VIEWS

Two aspects of the general issue of lighting take on increased importance in hillside housing. One is solar access and the other is view access. Solar access refers to how much sunlight strikes the site during the day. It is affected by the orientation of large elements which cast shadows, such as rock outcroppings or other buildings. On a South facing slope, solar access is improved since the site is tilted up more perpendicular to the sun's rays. On even moderately steep North facing slopes solar access becomes difficult if not impossible. Figure 51 illustrates the effect of slope orientation on the number of hours of

sunlight a site might see during a day at the latitudes of the U.K. East and West orientations show a one third (33%) decrease in sunlight at midwinter on a 30° slope. This leaves enough light so that there is at least the possibility for getting a reasonable exposure. On a North facing 30° slope, or even a 20° slope, there would be no sunlight at midwinter. If the problems of buildings casting long downhill shadows on North facing slopes are considered as well, building on a North facing slope looks even gloomier.

Though solar access is difficult on North facing slopes, it is not completely impossible. "On North facing slopes a long sloping roof of no more than about 40° elevation (at the latitudes of the UK) can enable summer sun to reach most parts

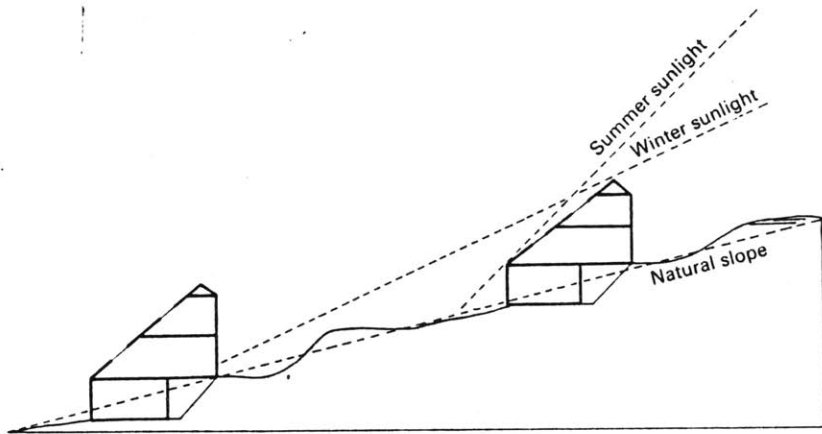

Figure 52. Some sunlight is possible on North facing slopes.
 (Simpson and Purdy, p.60, 1984)

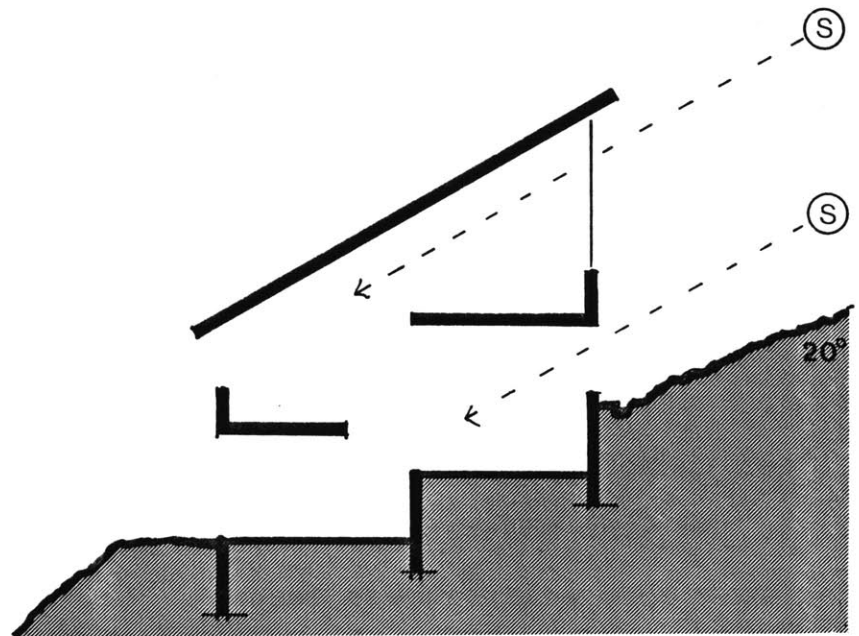

Figure 53. High South facing windows and clerestories are helpful on North slopes. Section stepped to accept light.

of North facing gardens." (1) Figure 52. Clerestories or high South facing windows are also effective on North facing slopes. Figure 53.

On a South facing hillside, a slope angle of 30° (Boston latitude) will decrease shadow lengths on the North side of the house. The spacing of buildings with regard to shadow lengths can be calculated for North and South facing slopes as illustrated in Figures 54a,b. (Many municipalities will limit building heights to 35'). Houses can respond in shape to the angle of incidence of the midwinter sun, in order to protect the sun access of other houses. Inside the house the sections can open up to the South to allow deep winter sun penetration and good

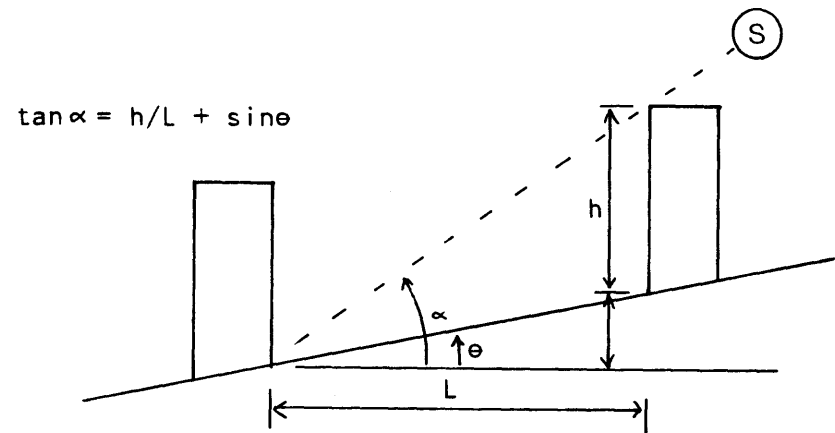

Figure 54a. Building spacing on North facing slopes.

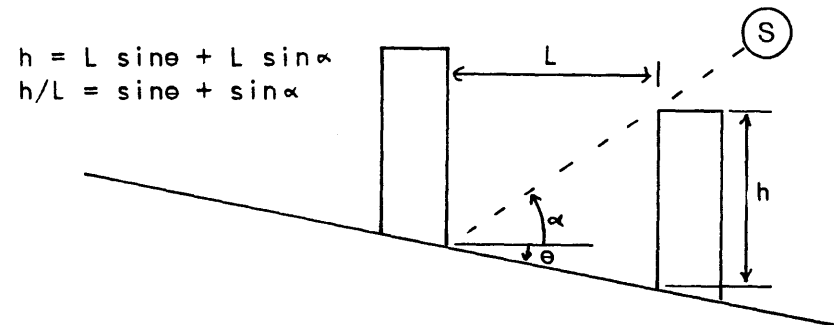

Figure 54b. Building spacing on South facing slopes.

- e = slope
- alpha = sun azimuth
- h = building height
- L = distance between buildings

(1) Simpson and Purdy, p.60, 1984

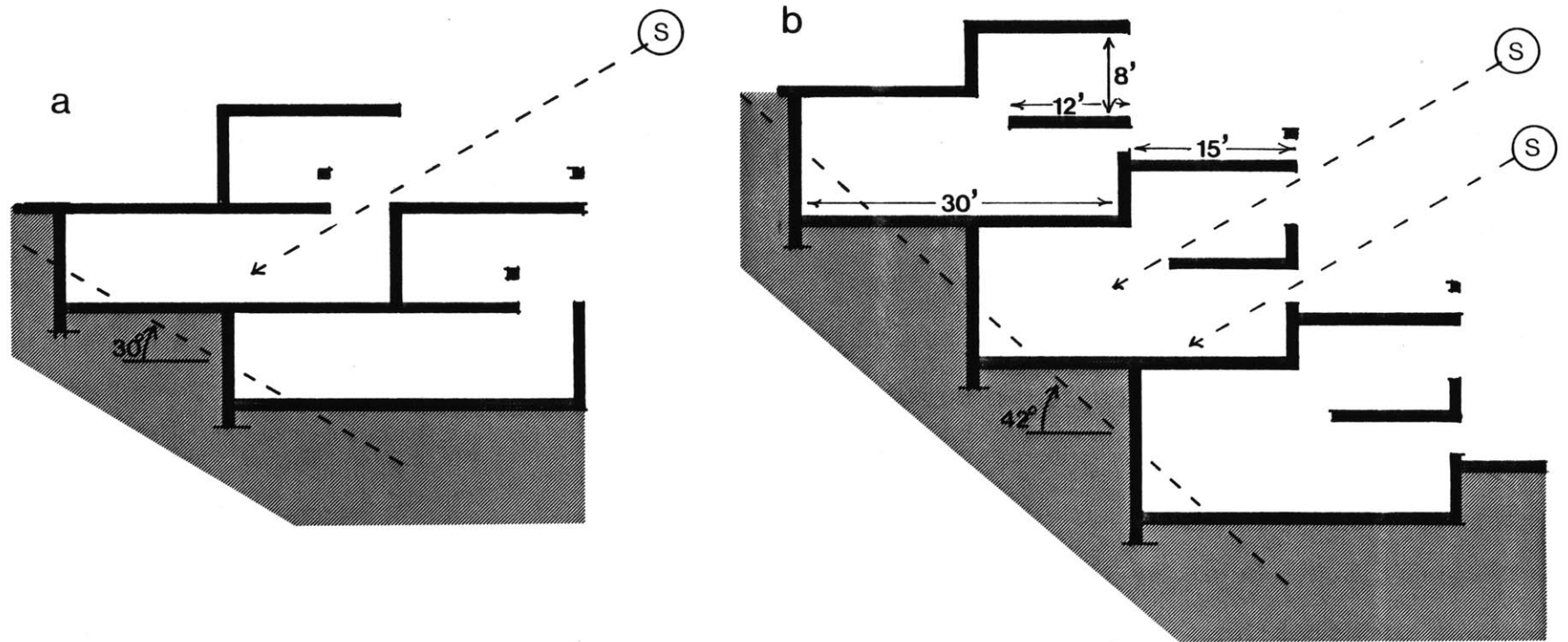

Figure 55. Section stepping to allow penetration of light.

sky access in the summer. Figure 55.

Indirect light from the sky will provide good summer illumination since the sky is a bright source of light.

The second aspect of this issue which takes on increased importance is lighting buried, or almost buried, edges. Some housing types characteristically tend to result in buried edges of buildings as the slope gets steeper. In a Terracehousing scheme, this is acceptable and the architect is limited to two or three lit sides. The lit perimeter can be increased in length and complexity to improve lighting.

In other situations the architect may want to fight for light access along the buried edge. There are several techniques for this. Stepping the section is one way of eliminating these dark buried edges.

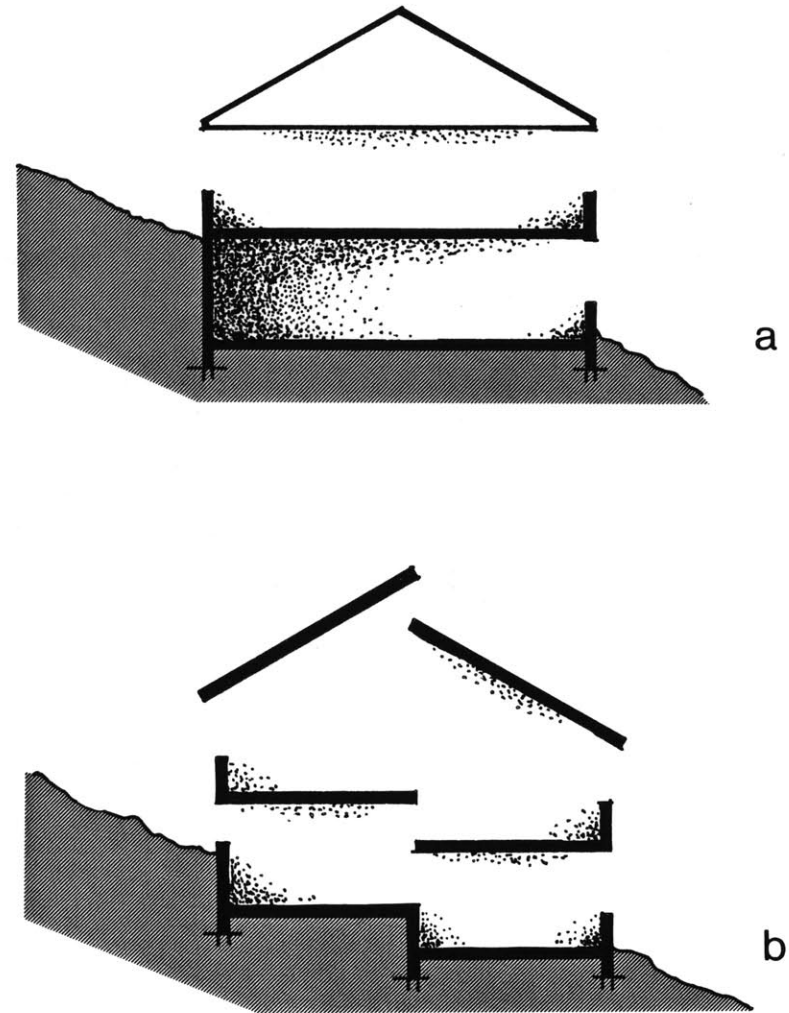

Figure 56. A. Back edge buried and dark. B. A stepped section provides space for a window.

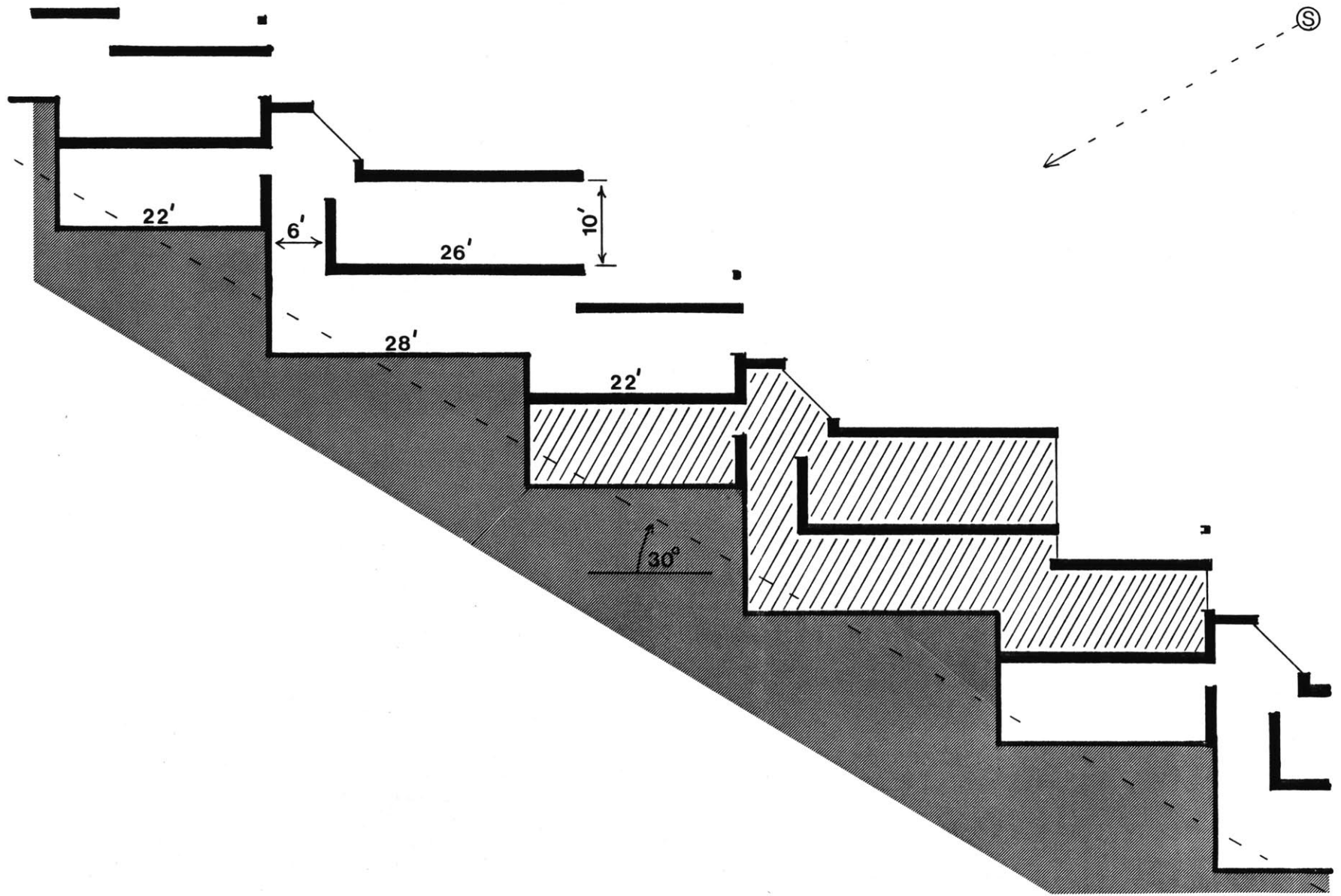

Figure 57. Lighting dark areas in Terracehousing.

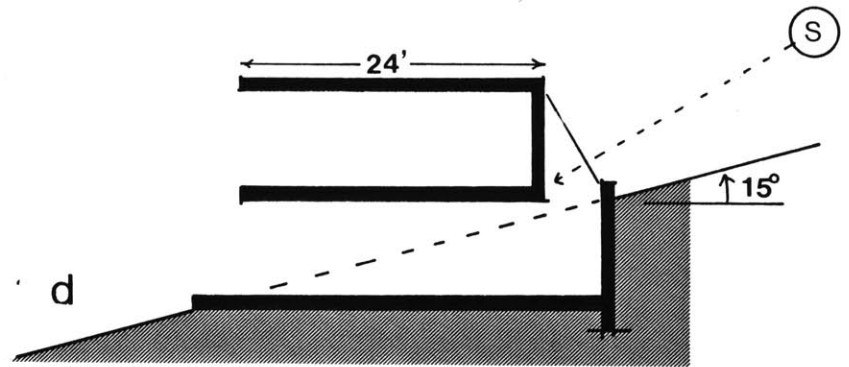
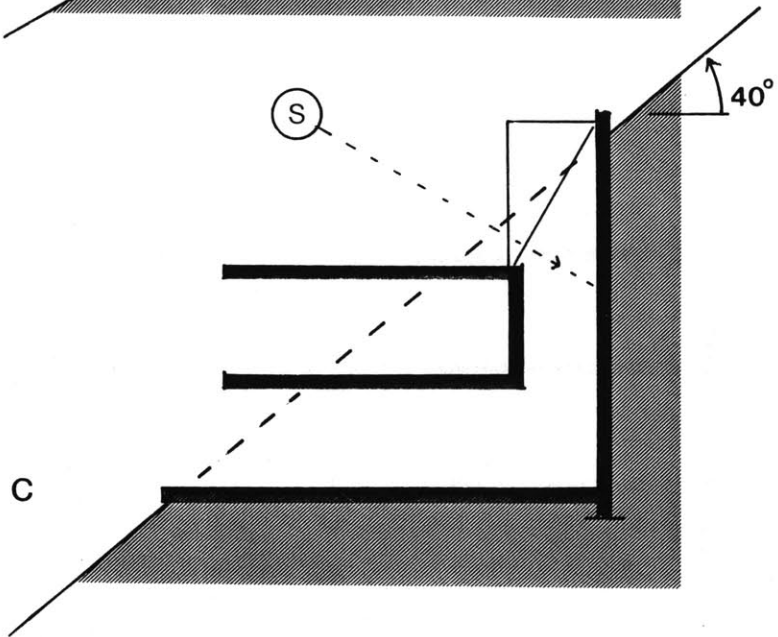
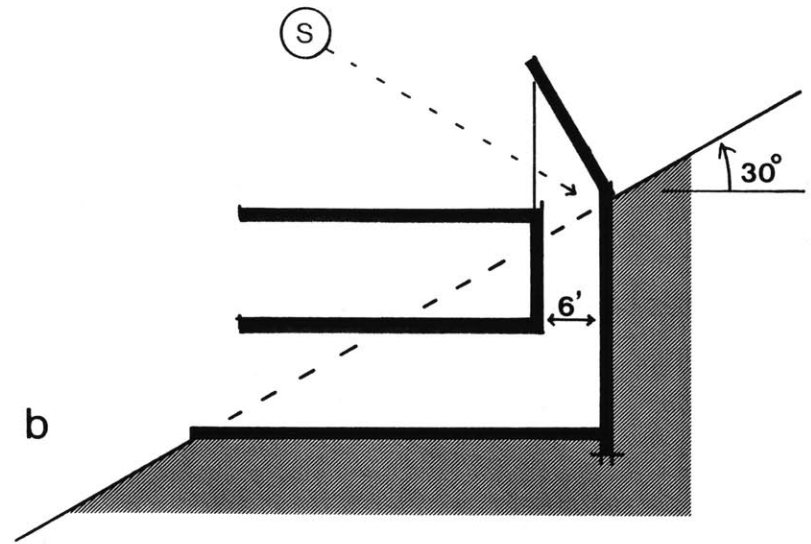
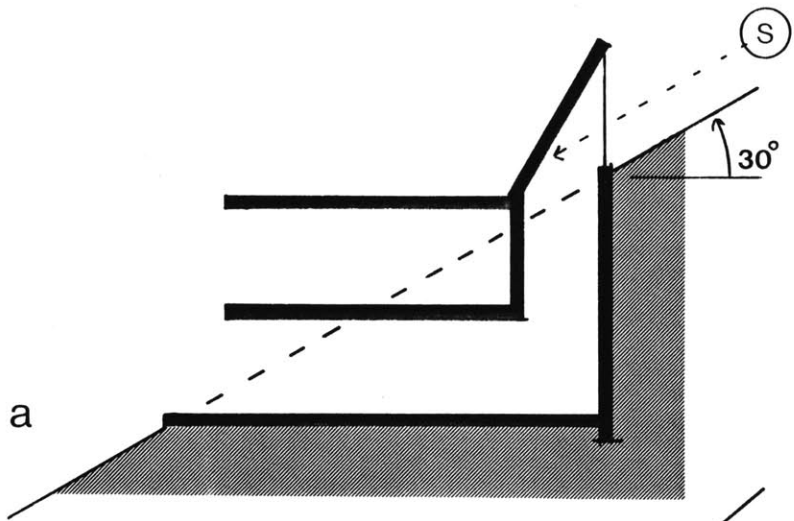

Figure 58. Four lightwell schemes for lighting buried edges.

Figure 56. On a larger scale, specialized sections can bring light deep into spaces. Figure 57. Another basic technique is to set the house apart from the hill. Figure 58. The space between the house and the hill becomes an opportunity for light access. This principle is used when large cuts are made in the hill, and is an underlying principle in the pole structures which are likewise set apart from the hill. On a smaller scale, a little horizontal shift allows light in. Figure 59. This approach can be used in many ways on both North and South facing slopes.

There are also several devices that work as short light shafts. Figure 60 a,b,c. Scheme B gives more light than A because the glazing is more perpendicular to the sky light source. On the second

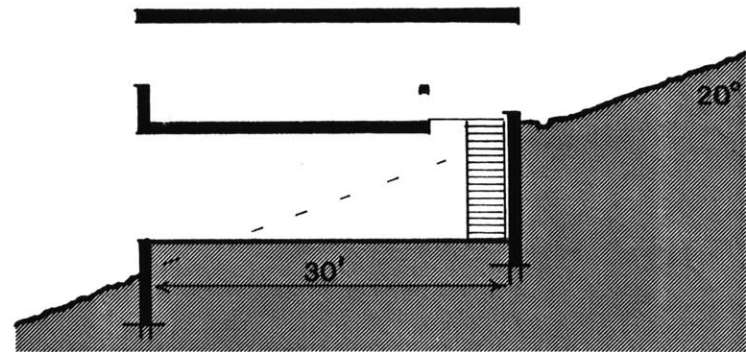

Figure 59. Horizontal shift to admit light to buried edge. Access used as a light source.

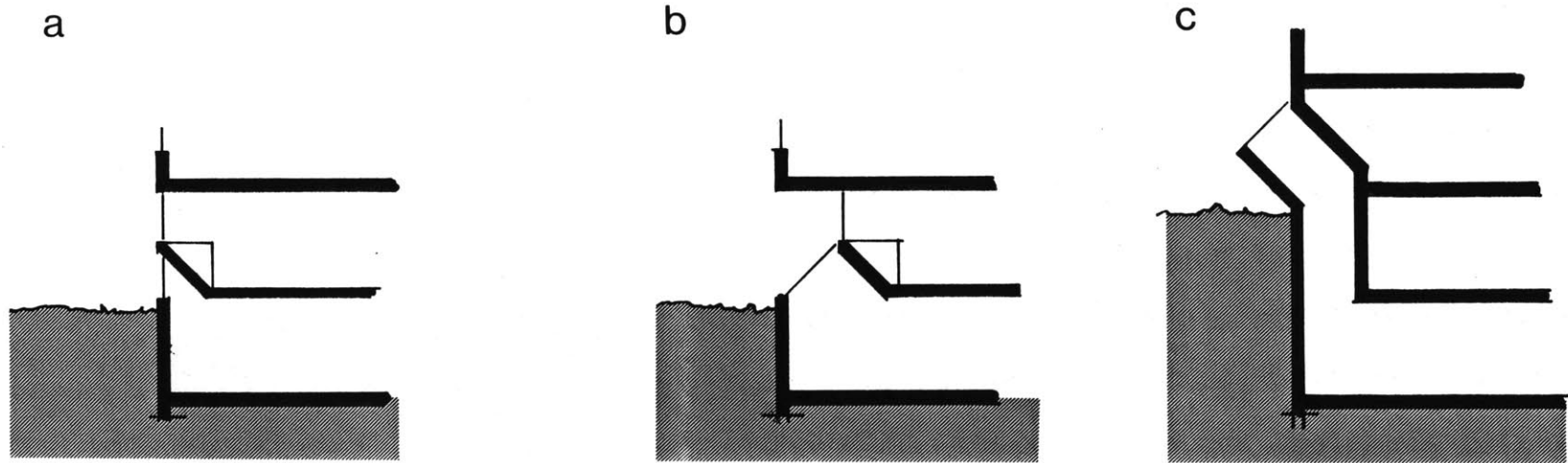

Figure 60. Light borrowing schemes for dark spaces.

floor a counter makes the space over the sloping surface of the light shaft useable. Scheme C is for a more deeply buried situation and uses up more second floor space. Scheme B can be built as a bay window, bulging out from the foundation and lit from above, as shown in scheme D. These types of solutions will

light small areas only on the order of 12' wide, dependent on particular sizes and configurations. (Some larger light shafts are shown in the section on Cuts and Buttresses.)

If the access is uphill from the house, privacy can be a problem with these types of lighting designs, as strangers

may be able to look down into one's living space. Figure 61 shows a way of combining plantings with a light well in order to preserve privacy. (1)

Privacy becomes an issue because people want to see out of their houses as well as having light come in. Overlooking of other people's yards is prevented by careful planning, and if necessary, screens or blinders can be remedially attached as a separate system. Jacques Blumer of Atelier 5 argues convincingly that in order for housing to work as a public system of spaces, the private spaces must be sacrosanct, so that people can withdraw if they wish. This means residents will truly have the whole range of choices, from public to very private.

(1) Hillside Homes, p.15, 1961.

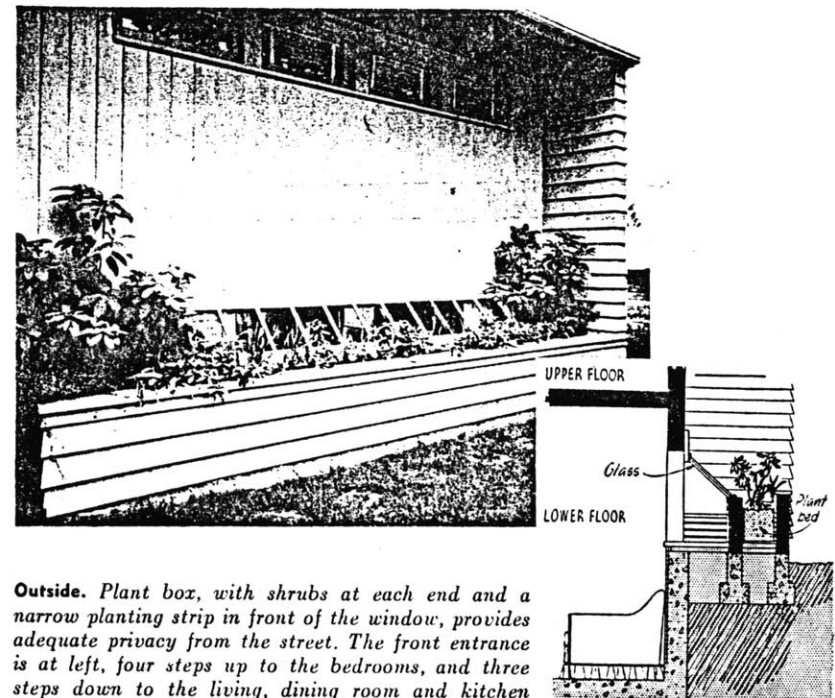

Outside. Plant box, with shrubs at each end and a narrow planting strip in front of the window, provides adequate privacy from the street. The front entrance is at left, four steps up to the bedrooms, and three steps down to the living, dining room and kitchen

Figure 61. Privacy v.s. light.
Arch: Galen Bentley, Seattle, Washington
(Sunset Ideas for Hillside Homes,
p.15, 1961)

Where one unit unavoidably looks down on another's private space, trellisses can be used to maintain privacy.

In Terracehousing, where one patio can overlook another, special consideration must be given to the edges of the patio. Figure 62. Plantings and suspended gardens are costly but their effectiveness may make them justifiable. Another problem which can arise on hillsides is that of overlooking roofs of other units. Figure 63. A sea of flat black asphalt can be particularly unattractive. A thin layer of turf on which unmown grass is grown such as was used at Halen, Switzerland by Atelier 5 will ease this problem.

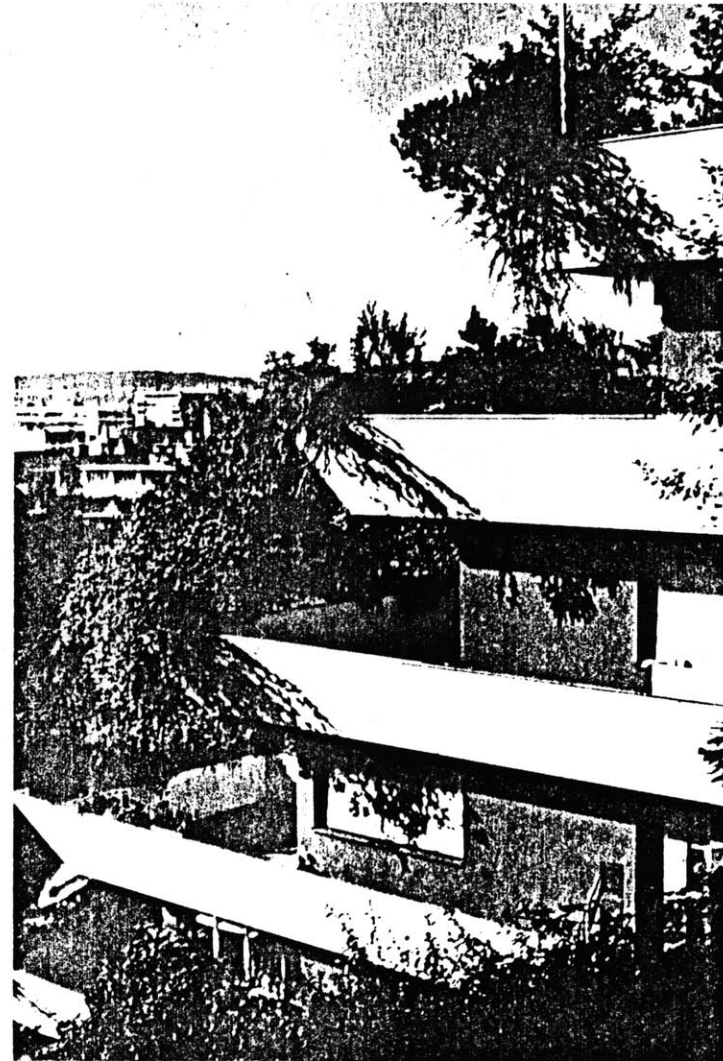

Figure 62. Detailing of patio edges to maintain privacy. Arch: Stucky and Meuli, Zug, Switzerland, 1961 (Abbott and Pollit, p.140, 1980)

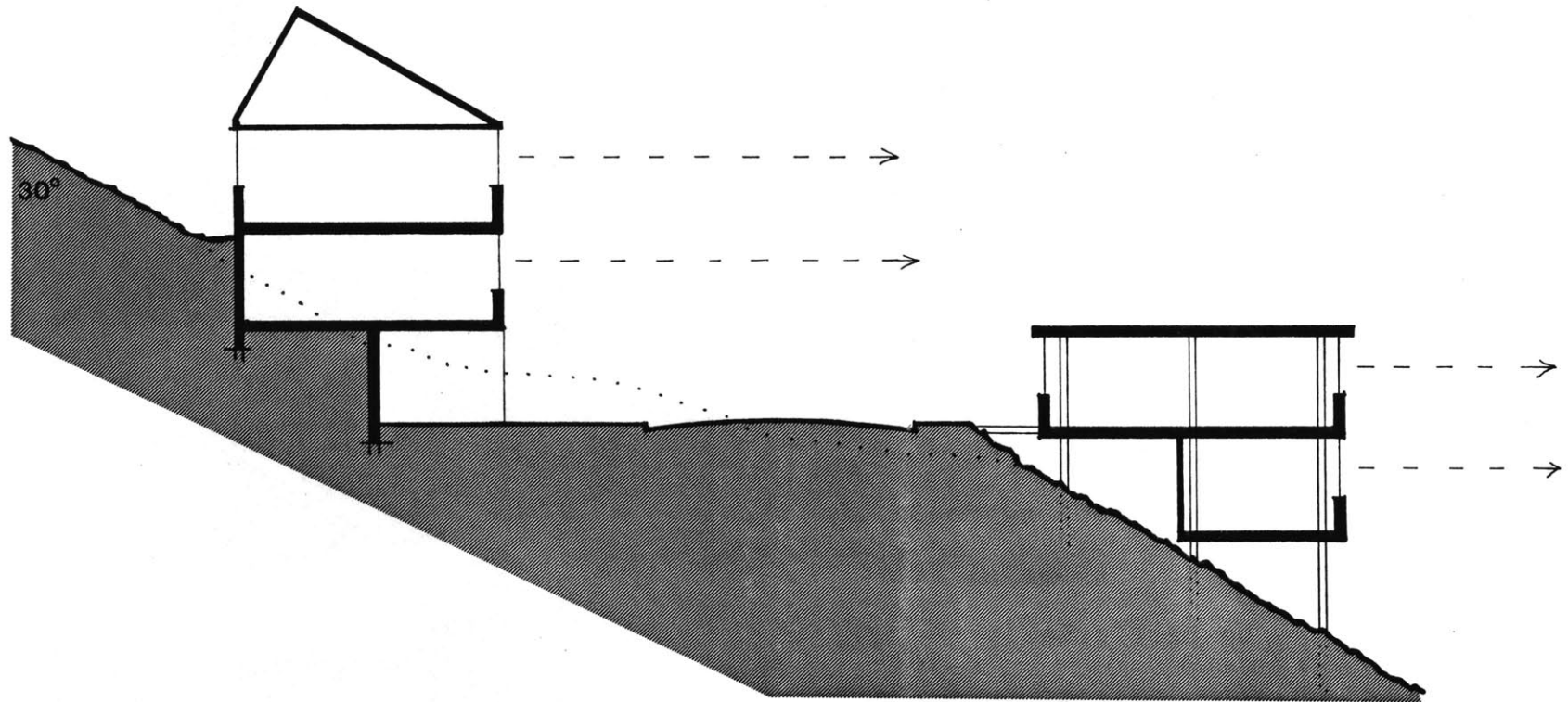

Figure 63. Flat roofs on downhill houses improve views for uphill houses. Grass can be grown on flat roofs to reduce visual impact.

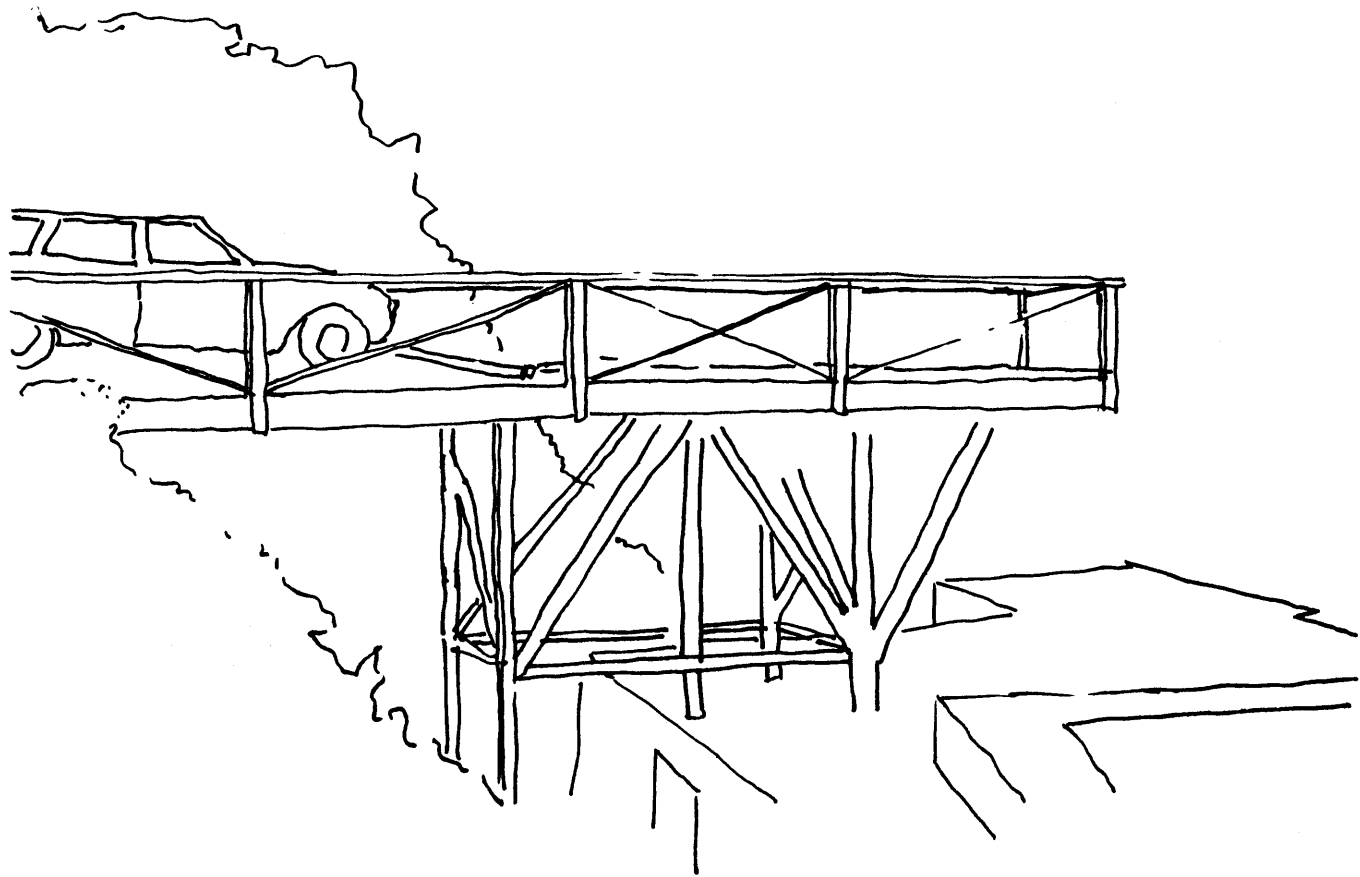

Figure 64. Platform for car above house.
(Planning and Landscaping,
Hillside Homes, p.6)

PARKING

One of the most restrictive problems of building housing on hillsides is the car. It is first of all very difficult to build the roads to bring the car to the site. Secondly it is difficult to store the car on the site. This is because a car requires large amounts of relatively horizontal surfaces to travel, turn, and park upon. Horizontal space is the least available item on a hill. Curbside parking is the simplest solution but it becomes restrictive as the slope gets steeper because it requires a 40' wide road. At a parking ratio of 2 cars per unit, curbside parking limits density to about 12 d.u./acre. (See appendix figure 86).

Offstreet garages are easily built

downhill of the road where cars can be supported on platforms propped up off the hillside. Figure 64. Uphill this becomes a problem because the required setbacks mean digging huge holes in the hill. The house must be set back a minimum of 10' so that the driver of a car can back halfway out and look both ways before backing out into the roadway itself. Adding another 20' for the car's length gives a 30' setback from the edge of the right-of-way.

Because of the need for parking, houses uphill from the road will tend to be cut into the hill, while downhill houses will tend to be disassociated from the hill. This holds truer as the slopes get steeper.

A third parking scheme is the two car LIFO (two cars, last one in is the first one out), which has the small drawback

Figure 65. Housing organized around parking court.

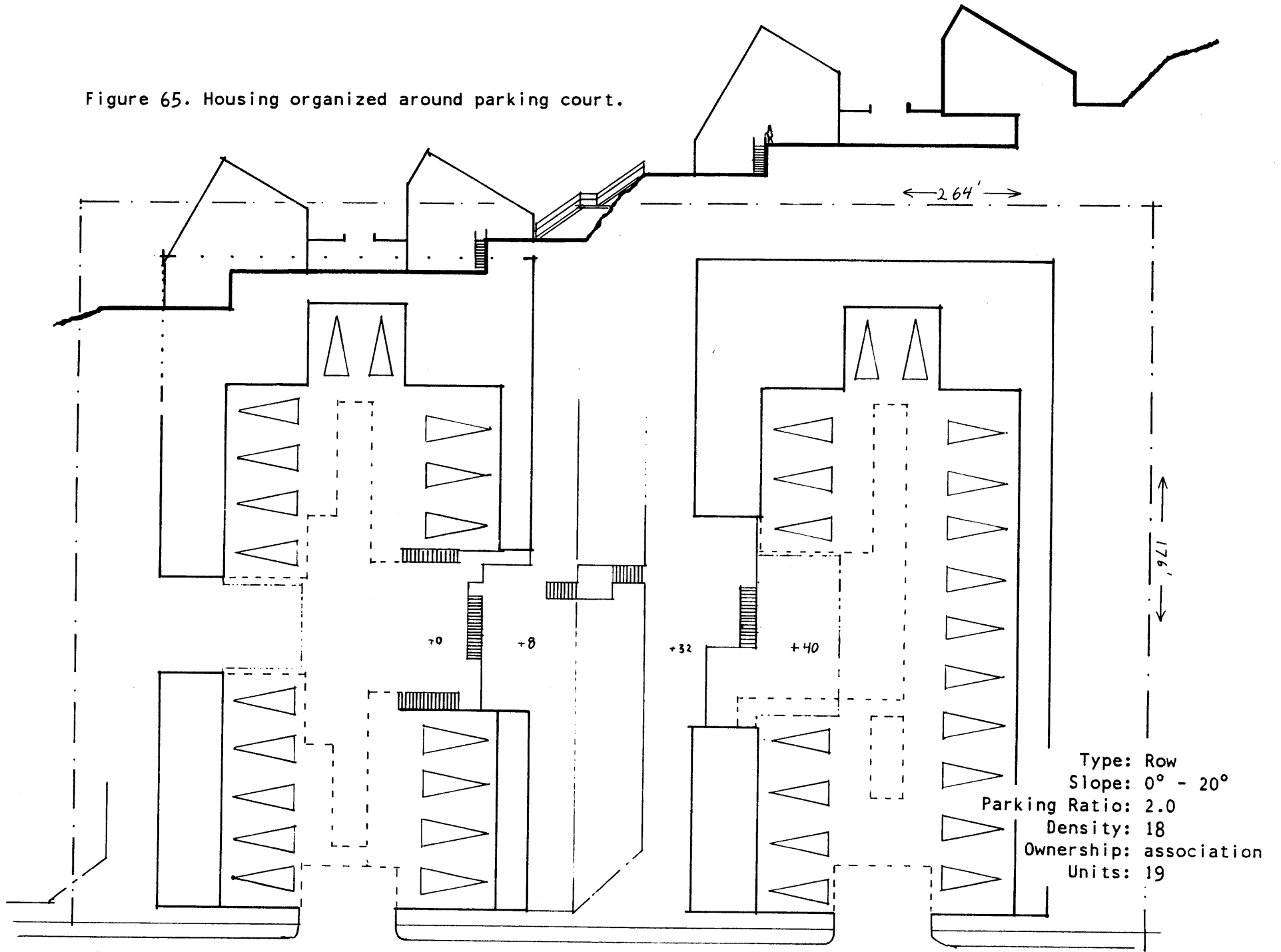

that one car is not as accessible as the other. (Someone may have to get used to sharing their sports car.) This system is much easier to use downhill than uphill and allows housing density to reach about 38 d.u./acre. (See appendix figure 92).

Housing can be organized around a parking court in a very urban way. This approach is very difficult on slopes steeper than 20°. Figure 65 illustrates one possible arrangement. With a parking ratio of 2.0, gross density can be 18 d.u./acre or if a parking ratio of 1.5 is acceptable, the gross density can be 24 d.u./acre. This assumes that every unit gets a 25' by 20' yard. The access road in this scheme deadends in the housing court and must be parallel to the contours.

Structured parking is also possible

but quickly becomes a massive intervention on slopes steeper than 20°. Structured parking, set deep into the ground can generate a large amount of fill which may be useful. At the toe of a hill structured parking can form a platform on which the housing can be built. In general on slopes steeper than 20°, the need for structured parking raises serious questions about the appropriateness of the project.

One interesting solution proposed by Atelier 5 is to put structured parking at the bottom of the hill and provide mechanical lift access. Space saved on parking can be used to increase density. This is a familiar pattern for highrise apartment buildings. On some sites it might be possible to place structured parking on the North side of the hill and

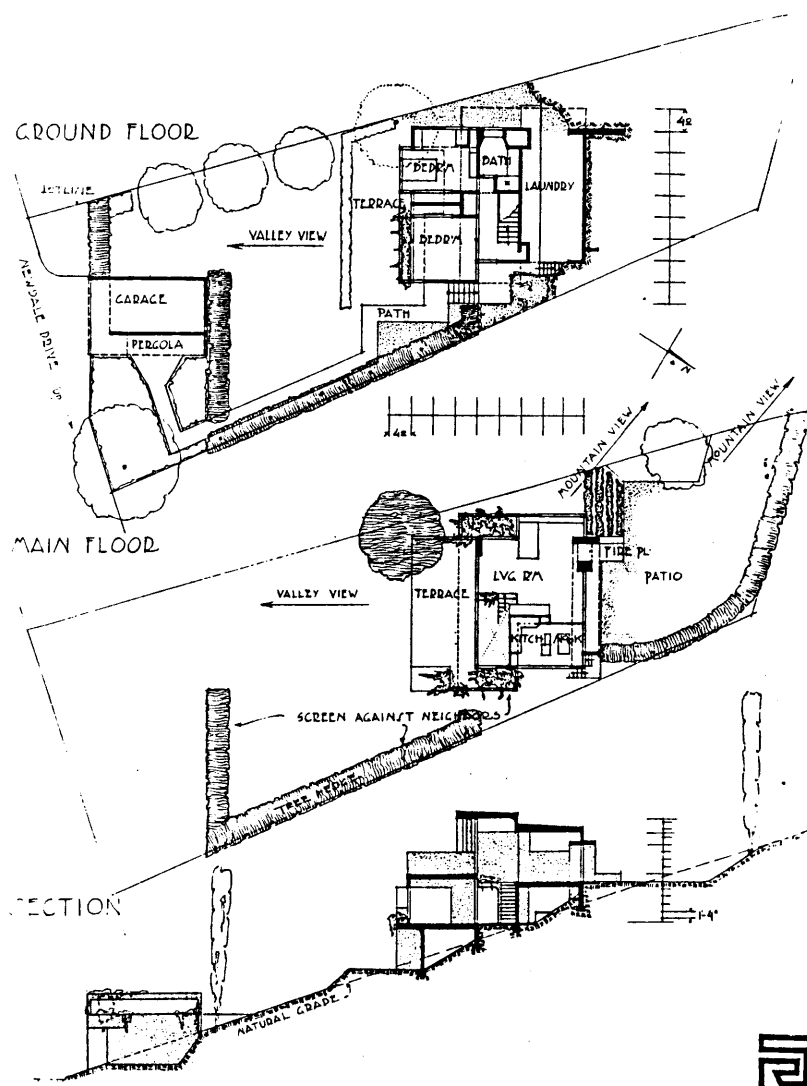

Figure 66. R.M. Schindler, House for R.F. Eliot, Los Angeles, 1936. (Gebhard, p.120, 1971)

provide mechanical access to housing on the South side. This would be an appropriate use of the land.

This avoids the problem of how to get the car up the hill. Not bringing the car to the house is a commonly used option in low and mid-density housing on slopes up to 30°. Figure 66.

Mechanical access systems must be carefully designed not to have the neighbour separating properties of an elevator. One method for avoiding this problem is to have a stop on every fourth or fifth level. People can disembark and walk down a few floors with their groceries, or maybe up one. When they go out again, they can still walk down with their garbage. This system promotes social interaction and obviates building many expensive elevator stops. A project

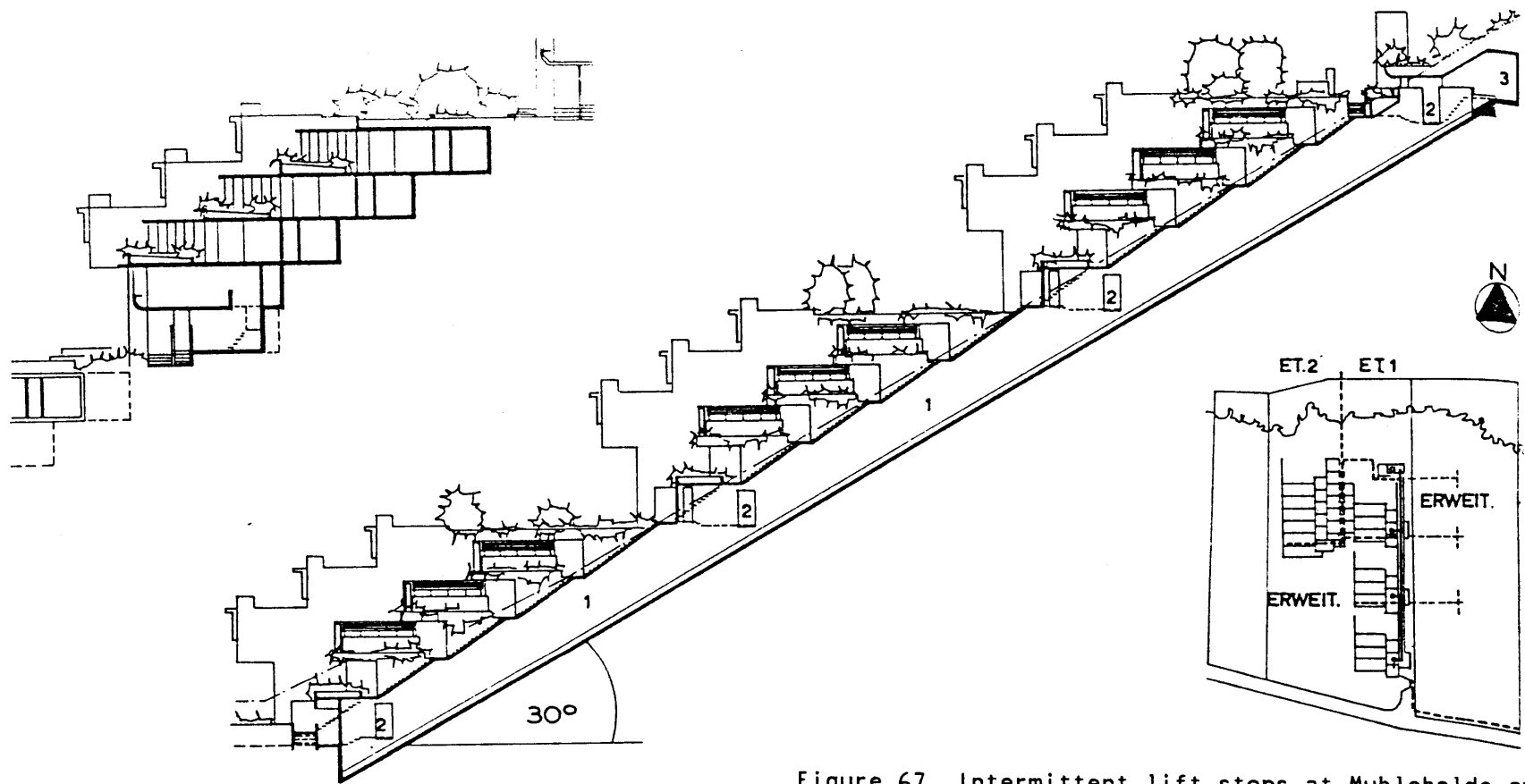

Figure 67. Intermittent lift stops at Muhlehalde am Bruggerberg. Arch: Team 2000, 1963-6 (Riccabona, p.28, 1972)

which works like this is Muhlehalde am Bruggerberg in Umiken, Switzerland. Figure 67. It would seem that if the American public, which is tightly attached

to parking within a stones' throw of their front door, can become accustomed to elevators, they could easily get used to a system like this.

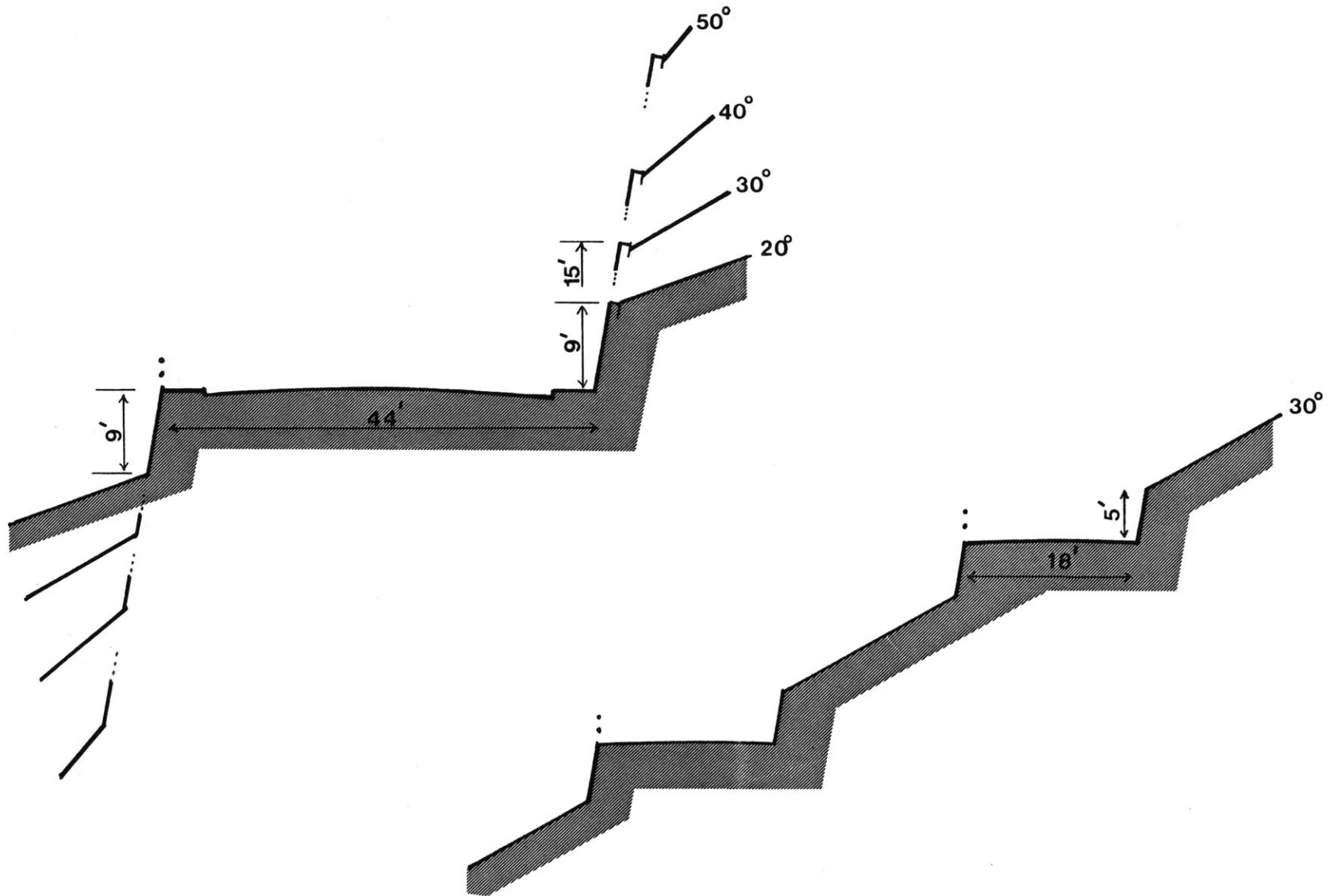

Figure 68a. Road building on steep slopes.

Figure 68b. Example of split roadway, note smaller retaining walls.

AUTOMOBILE ACCESS



Countless solutions to the access problem exist, and fall into two basic categories. One is automobile access and the other is pedestrian access.

Access by car is unhindered until the slope reaches an angle of 6° . Above this, with few exceptions, a road cannot go directly up a hill. As it becomes necessary to move parallel to the contours, the standard subdivision access patterns remain generally the same. One difference is that as the slope gets steeper the garages and parking will tend to hug the street. The houses may or may not follow suit. Sections from the City of Brea's Hillside Policy illustrate configurations up to 20° . Figure 14. Note that the downhill car can enter

perpendicular to the contours and street, parking close to the house. The uphill car must come up a driveway at a diagonal to the contours. This takes up more space, reducing uphill densities.

Road construction is a costly and difficult part of building on hillsides. Using the 44' right-of-way needed for a collector road in figure 70, one sees that a road can be established on a 20° slope by building an 9' retaining wall on both the up and downhill edges. Figure 68a. As the slope gets steeper, matters only get worse. This illustrates the major obstacle to access on a steep slope, and is a good reason for not building in many areas. As slopes get steeper guidelines for access show narrower streets, single loaded on the downhill side, thus avoiding massive cuts into the uphill slope.

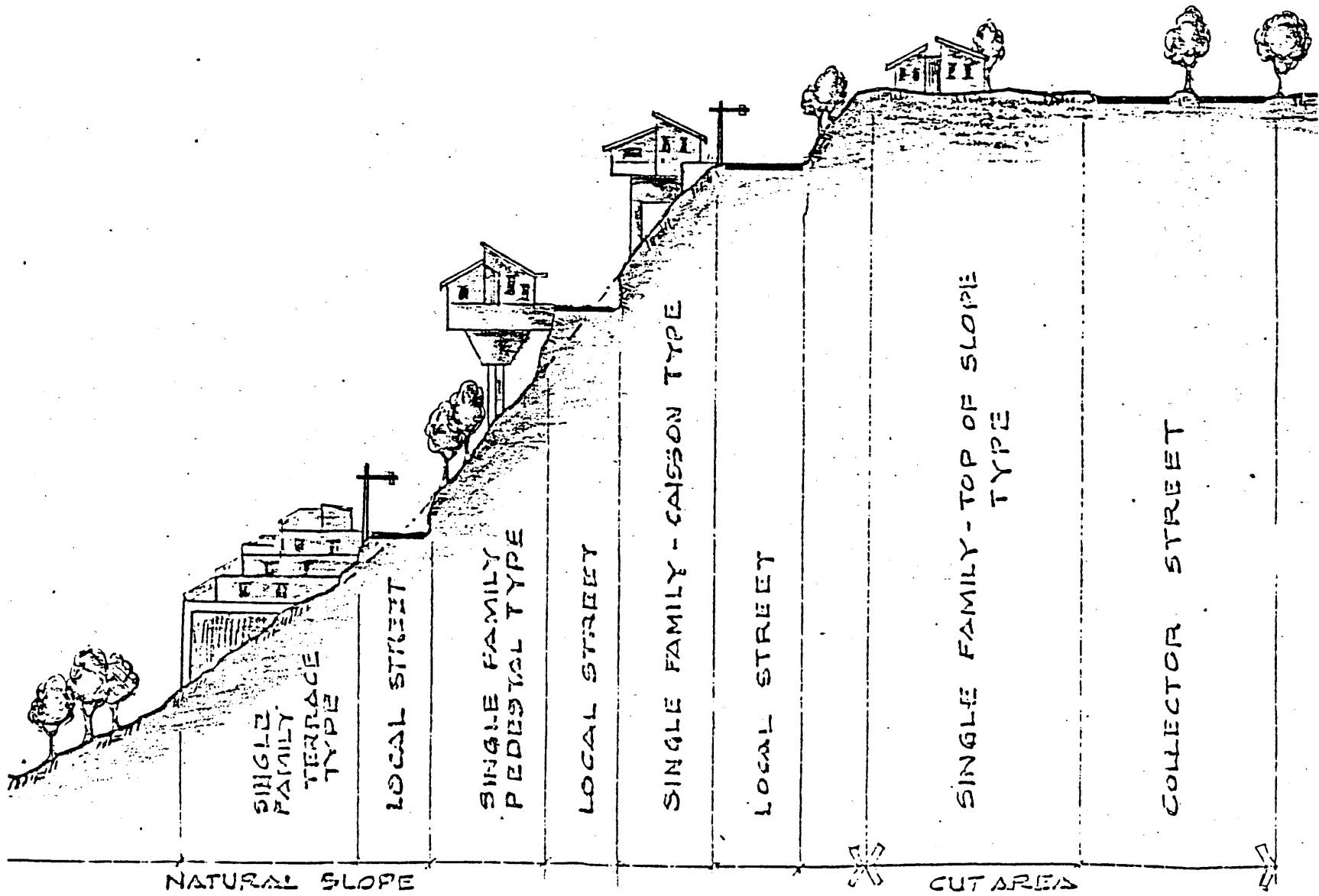

Figure 69. Typical section for extreme slopes.
 (Keith and Associates, 1975)

Figure 69. Note that the three housing types shown on this extreme slope are Terracehousing, pedestal or pole, and caisson (pier).

Cul-de-sacs can be problematic on hillsides, especially if they are long enough to require a 60' turn around space for fire trucks. This is a very large intervention on a 20° hill (same size as the parking court in the previous section), even if the turnaround is reduced to the bare minimum of 50'. The following is a list of proposed maximally reduced standards for development from the Village of Roslyn Hillside Development Guidelines.

Cul-de-sacs - serving six or less units,
20' wide min.

Cul-de-cacs - serving more than six
units, 22' wide min.

Local streets - serving abutting
properties, 24' wide min.

Turning radius at the end of a
cul-de-sac, 50' not 60'

Street grades of 20% for short distances

These types of reduced minimum standards help the problem, but do not solve it.

Hillside Policy for the City of Brea provides these graphic guidelines for various street widths. Figure 70. Note that they take advantage of the opportunity to separate the lanes of the street. It is also recommended that all parking be off street and in no case should a parking lane be provided. This

Collector (no frontage development)*		<u>Maximum Grade</u> 12 %
Local (Sidewalk one side only)		15 %, or 20 % ** for max. length of 600 ft.
Cul-de-sac or loop street		15 %, or 20 % ** for max. length of 600 ft.
premise: Major Thoroughfare (no frontage development)		<u>Maximum Grade</u> 10 %

* Plus additional requirements for any pedestrian rights-of-way; 53 ft. Pavement on 59 ft. R/W where left turns are required.

Figure 70. Diagrams for minimizing impact of streets on hillsides.
(Keith and Associates, p.28, 1975)

is due to the excessive cost and difficulty in building a road wide enough to accomodate on street parking.

Separating the elements which make up the street is an important option. These elements are the two driving lanes, and the sidewalk(s). These elements can then be stepped up the hill to minimize the need for large cut and fill shelves. This method will require more space on the hill, but will probably be cheaper to install, as it requires smaller retaining walls. Figure 68b. It's long term stability is more certain.

Maximum recommended grades for driveways are similiar to ramps, a useful coincidence since they may thus double as pedestrian access. Post, et al. (1978) conclude that the most cost-effective gradient here is 7°, their criteria being

achievement v.s. road safety. (1) Driveways of up to 11° (20%) are possible but not recommended.

On a house by house scale, not bringing the car to the house, means added freedom in placing the house. This method works for houses both uphill, and downhill of the road, though it is more useful for a house downhill from the road. In this case, the car is left on a platform near the road. This allows access to very steep or irregular slopes. Access to a house downhill from the parking area is by way of bridges, ramps, and stairs. An uphill house is usually accessed by stairs.

Also see Simpson and Purdy for pedestrian and vehicle access.

Figure 71. FOOT ACCESS v.s. SLOPE ANGLE

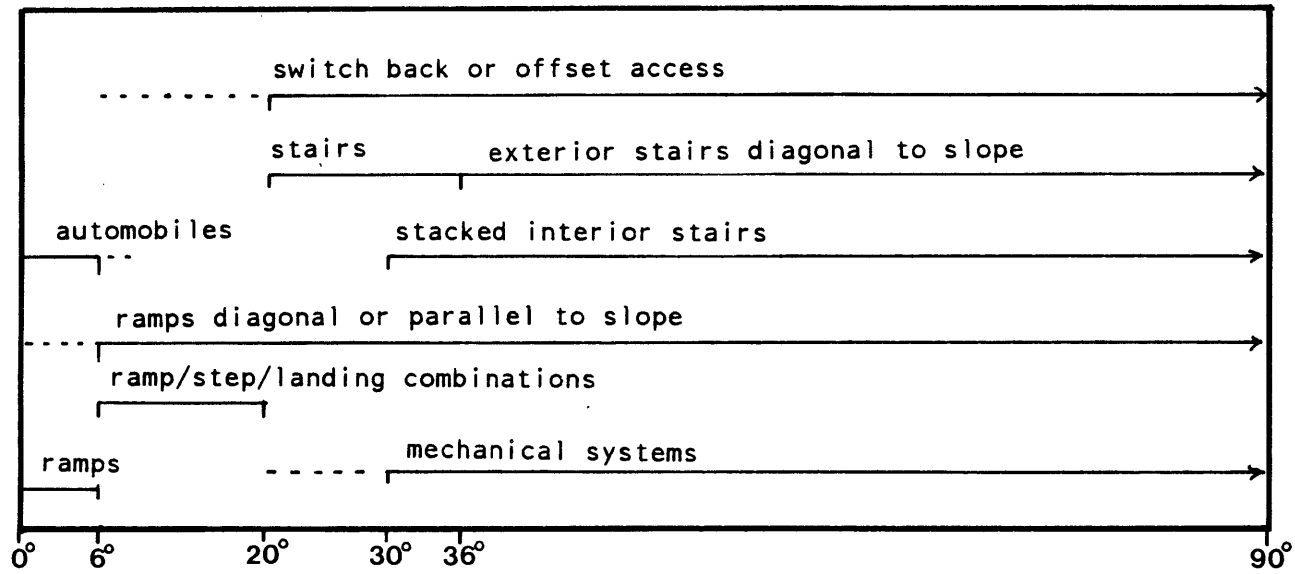

PEDESTRIAN ACCESS



Optimally, pedestrian access is predominantly horizontal and often is placed parallel to the contours if the slope is steep. For pedestrian access in a direction transverse to the contours, various techniques can be used depending on slope angle and density. Figure 71. Up to about 6° , a simple ramp can be used straight up the hill. (1) Transverse access steeper than this requires the use of steps and landings. A system can consist of many combinations of steps, ramps, and landings. These examples from Swansea shown in figure 72 illustrate a

(1)

Architectural Graphic Standards provides these figures:

- max. ramp residential = $7^\circ 8'$ or 1 in 8
- max. ramp public = $5^\circ 43'$ or 1 in 10
- max. ramp handicapped = $4^\circ 53'$ or 1 in 12

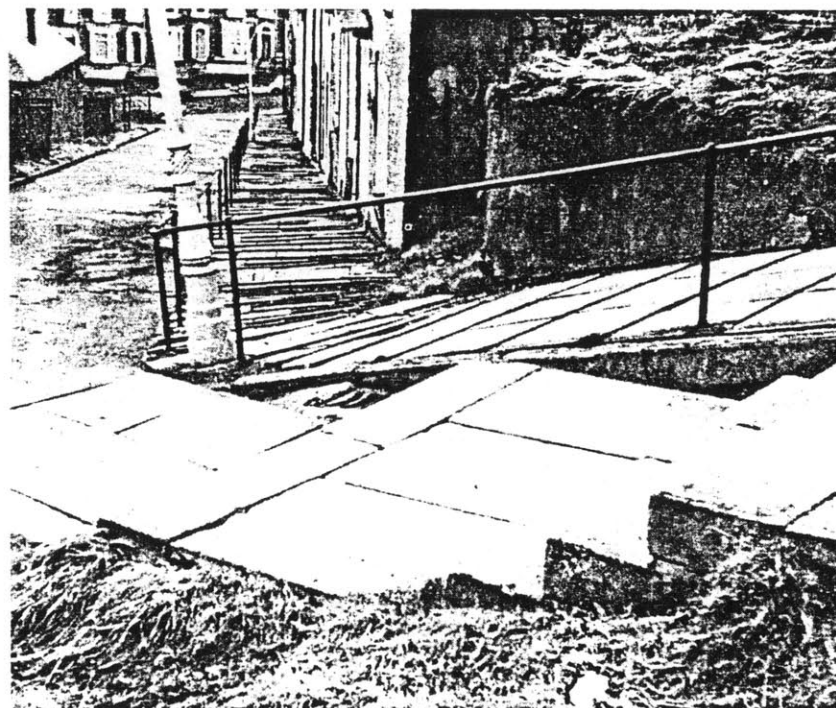

Swansea, South Wales: (*bottom left*) combination of ramp and steps with 'landings' at the front door entrances; (*above*) raised paving slabs in the ramp—laid across the line of the fall—give a degree of security when walking up or down. The combination of two methods of negotiating the slope have advantages for young and old alike

Figure 72a. Pedestrian access in Swansea, South Wales.
(Abbott and Pollit, p.53, 1980)



(Above and left) a steep hill visually lessened in gradient by a combination of materials and gently sweeping slopes (Minehead, Somerset, England)

b

c

Figure 72b,c,d,e. Pedestrian access in Swansea, South Wales.
(Abbott and Pollit, p.53, 1980)

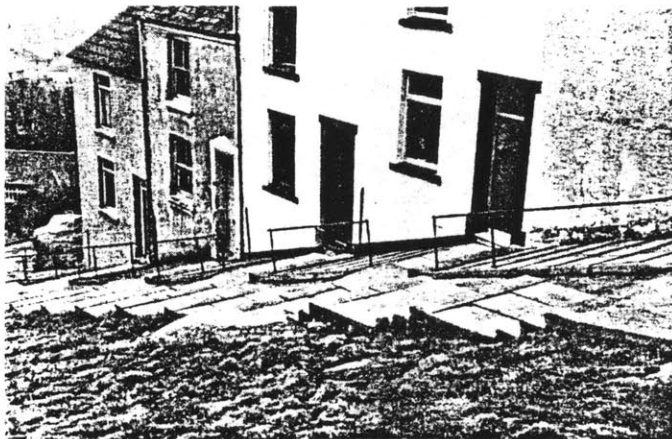

d

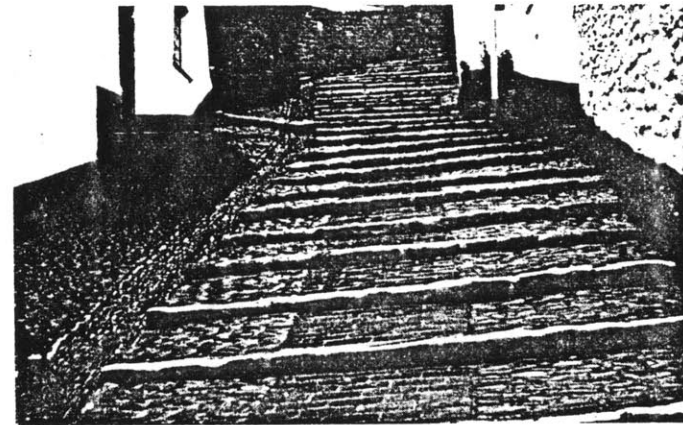

e

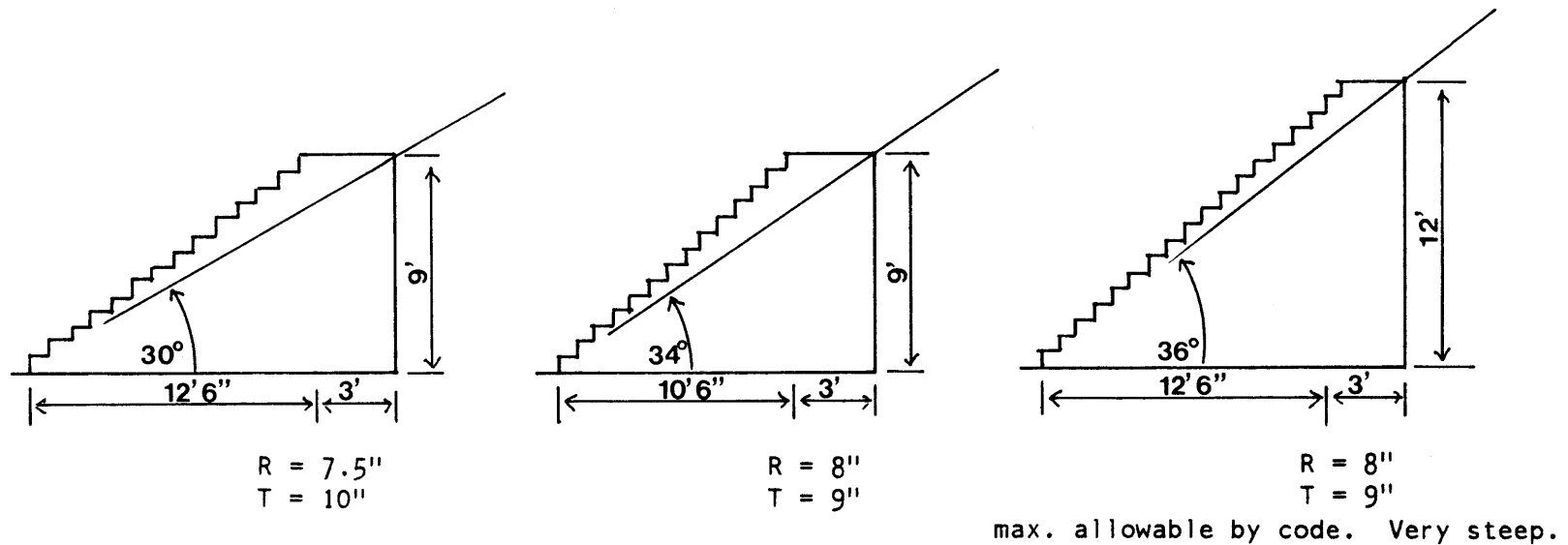

Figure 73. Stair and landing systems.

few possibilities. Ramps can be used on slopes steeper than 6° if switchbacks are used or if the ramps are placed at a diagonal to the contours.

Houses sited at a slight diagonal to the contours generate walkways and paths which are also diagonal to the contours. This generates an easy pedestrian access

system. (1) Pedestrian access need not rigidly follow automobile access.

The maximum slope negotiable by a stair and landing system is about 36° . This limit is set by building codes. Figure 73. This would consist of 12' (rise) sets of stairs and 3' landings. This would be exhausting to climb! A

(1) Simpson and Purdy, p.37, 1984.

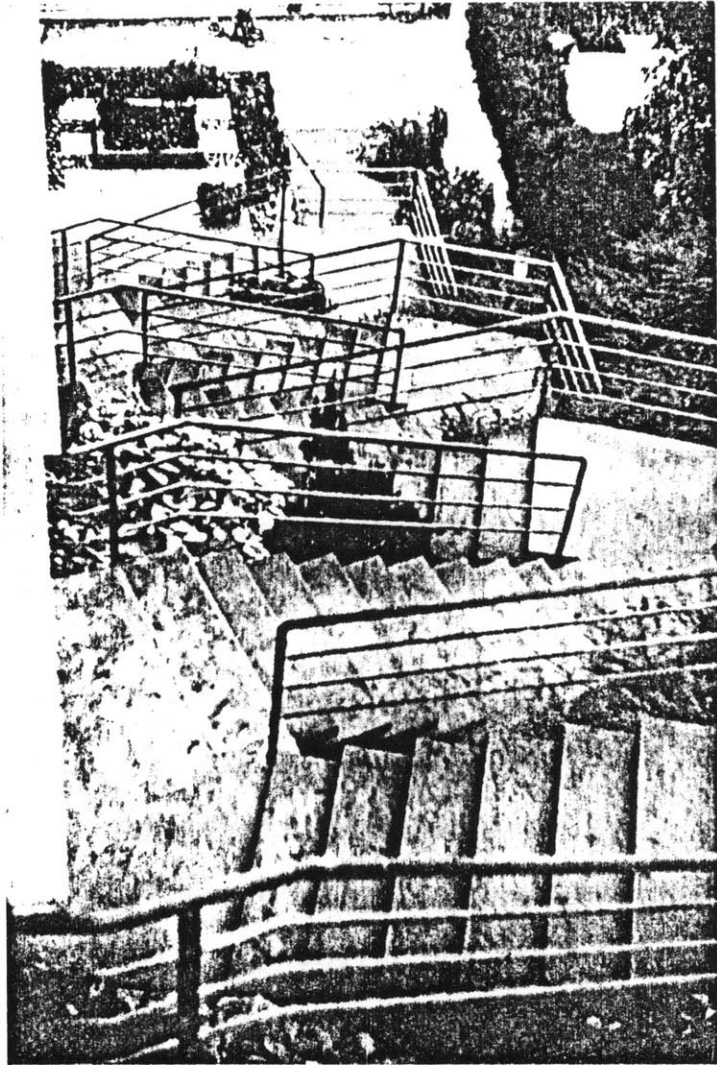

Figure 74. Switchback stairs with landings at half levels. Arch: Stucky and Meuli, Zug, Switzerland, 1961 (Abbott and Pollit, p.140, 1980)

switchback system with landings at half levels would be much easier to negotiate, and more comfortable to walk down than a long straight shot. Figure 74.

A constructed access path may be more advantageous than a path cut into the hill. Figure 75. Theoretically, on slopes steeper than 20° it would be cheaper. Certainly on slopes steeper than

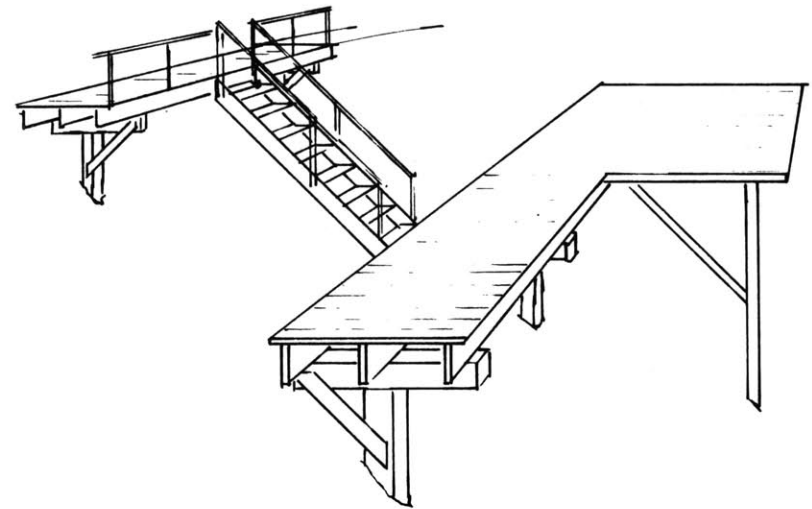

Figure 75. Access path constructed as opposed to being cut into the hill.

Eight apartments, each on a single floor, are divided among four separate buildings of unequal size. Grouped around a central garden court, they are well planned for maximum privacy, but as a result have fewer windows and somewhat less cramped layouts than the Landfair Apartments.

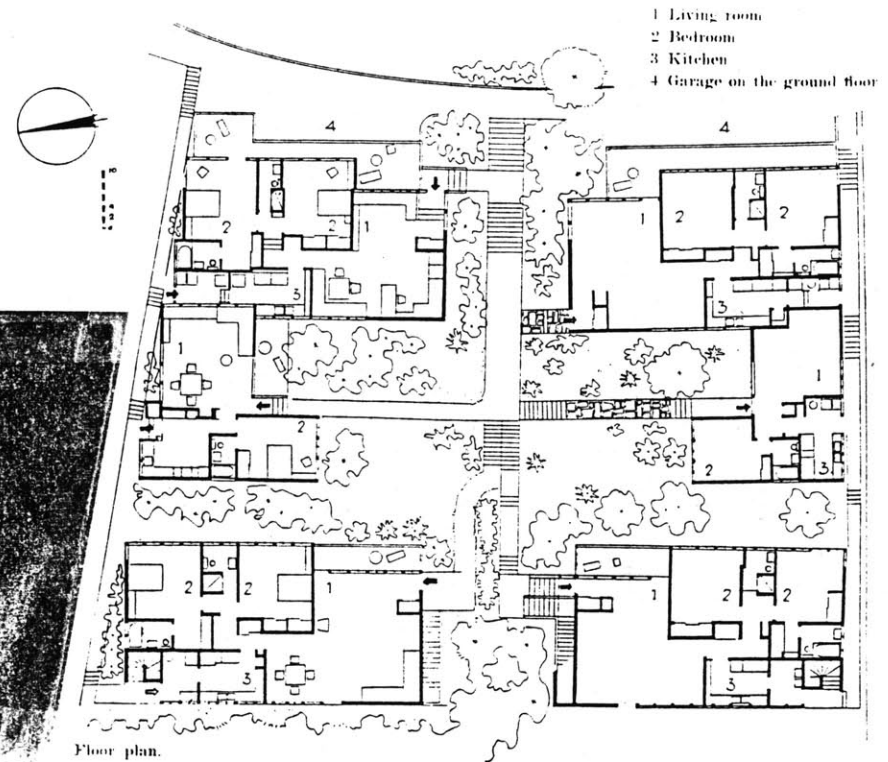
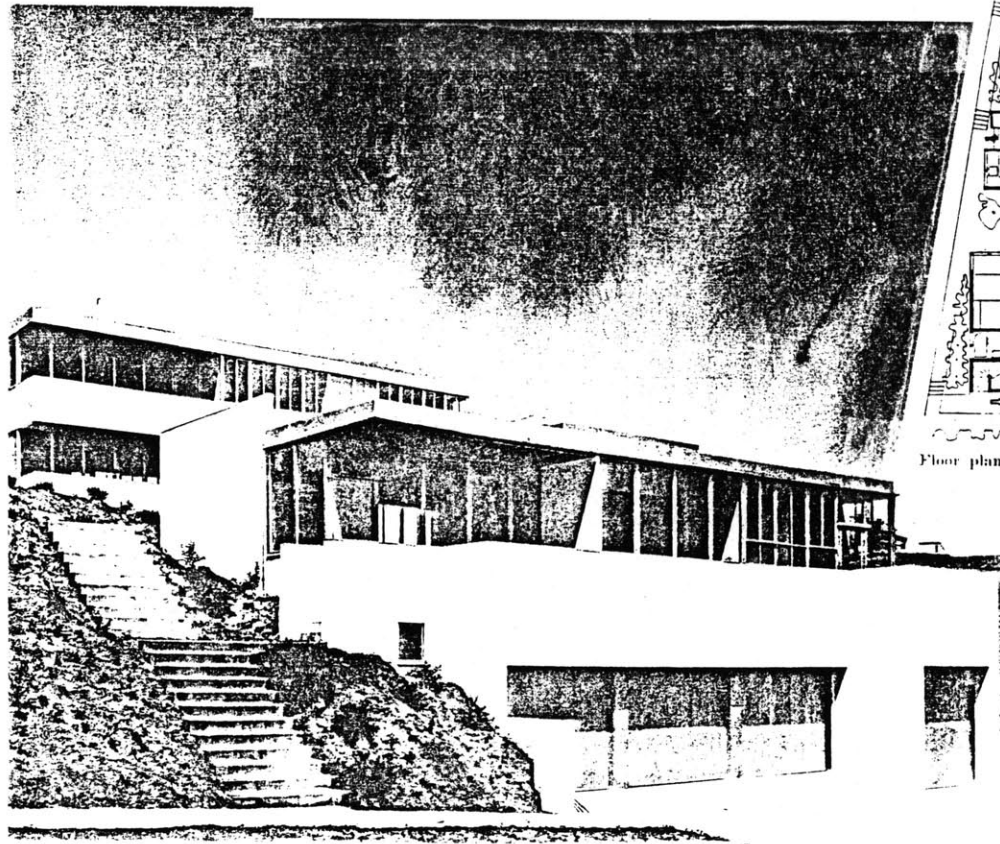

Figure 76. Access combined with gardens.
(Drexler and Hines, p.84, 1982)

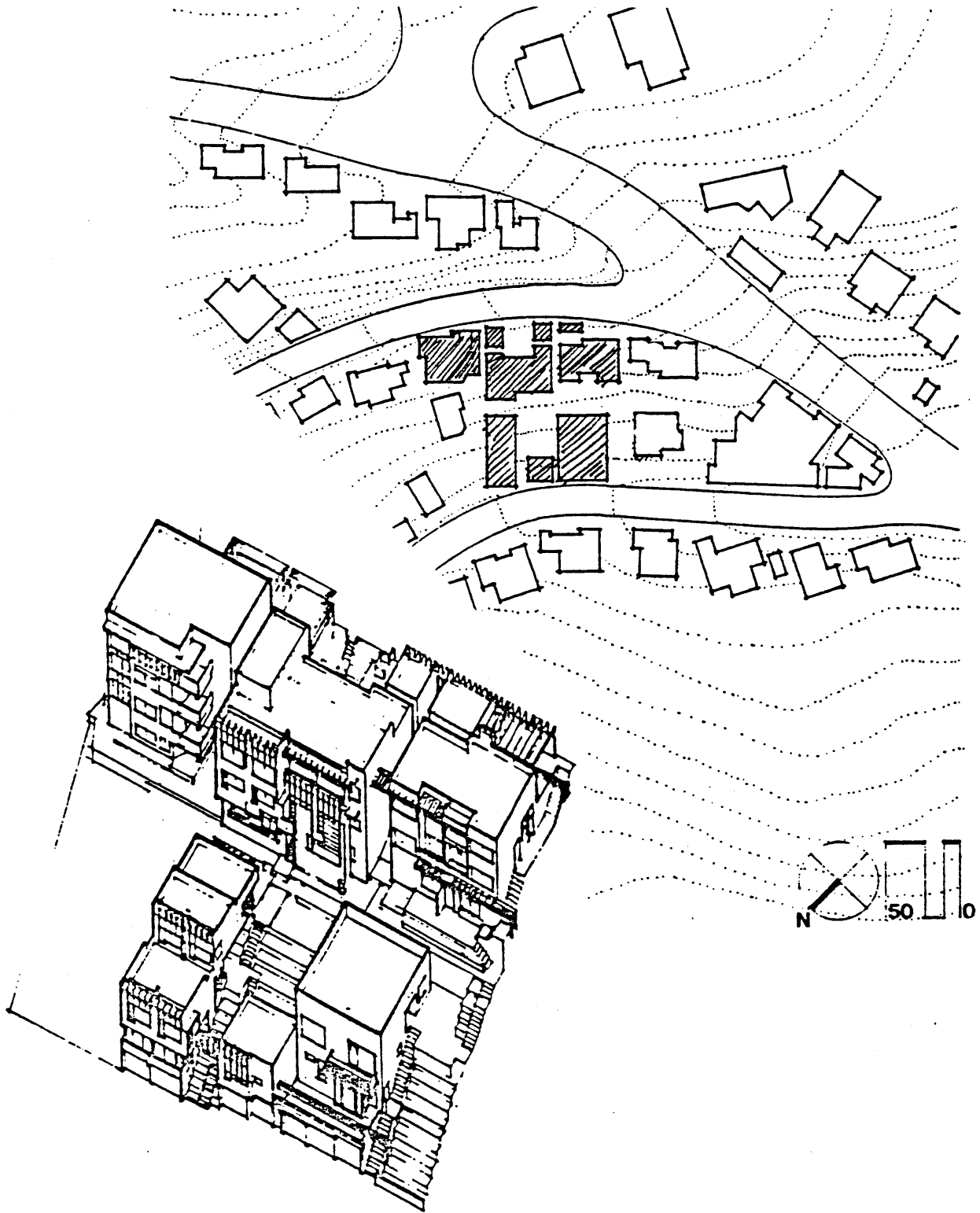

Figure 77. Access and community space form public framework. (Schindler, Sachs Apts.)

30° it will cause less damage to the land by avoiding erosion problems. The nature of the system is to disassociate itself from the hill, thus becoming useful on difficult terrain.

Access can be combined with yards and gardens to generate pleasant spaces between houses. Figure 76. Schindler did this in his Sachs Apartments in Los Angeles, CA. Combining access and community space helps generate a public framework which gives a project some internal identity. Figure 77.

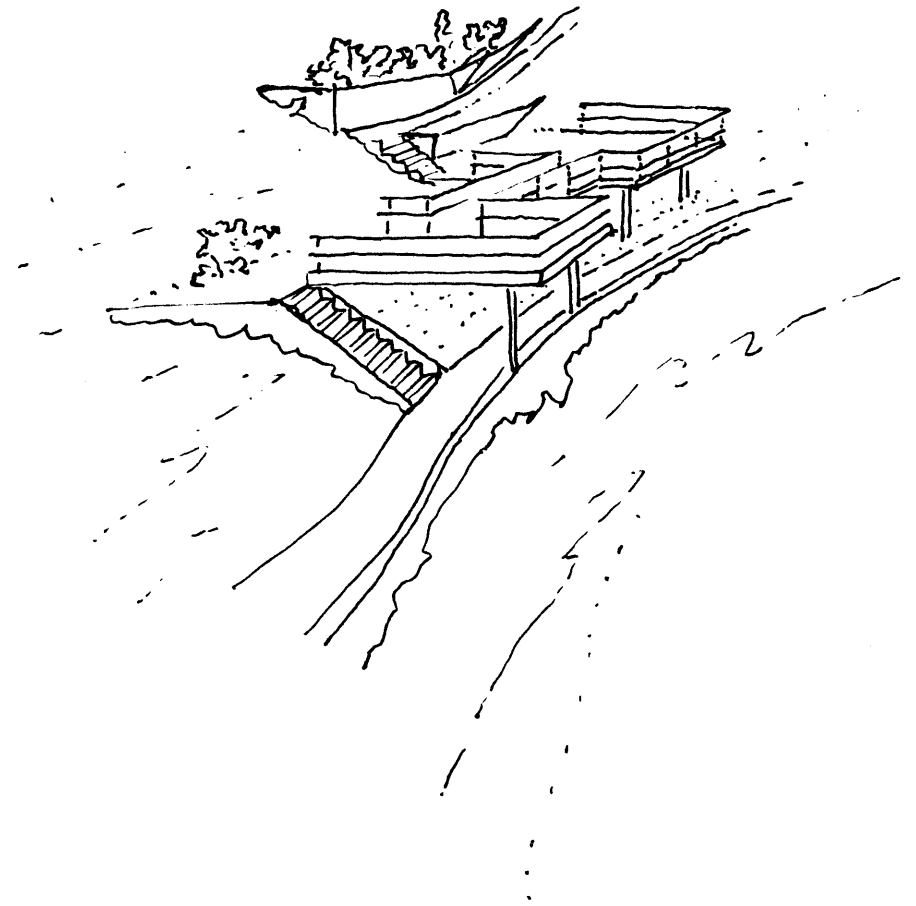
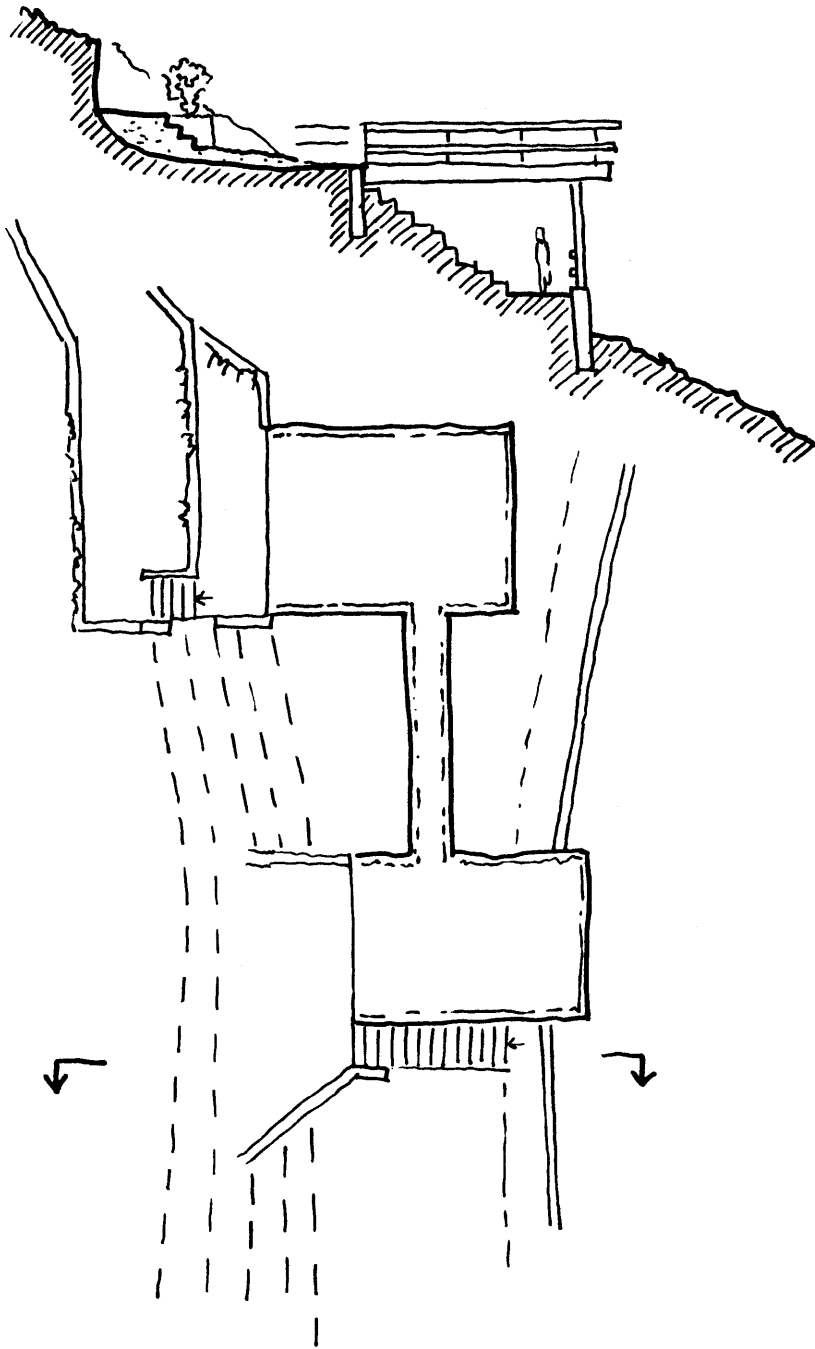

Figure 78. Decks combine with stairs to form access.



Community space is difficult to provide on hills because it generally needs to be large, say 25' wide, and the space wants to be on level with the street so that it is easily accessible from the public way. This is difficult because of the need to minimize road widths on steep slopes. It may be possible to use the street as a public space, as in a Dutch woonerf, but generally this will not be possible because of traffic. (1)

Playgrounds and community space must be made part of the public access system in some new way which is still accessible to parents with baby carriages.

Terracing and/or decks may be

combined with the access to create a public network which provides play space and includes landscaped areas. Figure 78. On hillsides special attention must be given to edges which children may be prone to falling off of. Some thought should also be given to the possible dangers of sledding in the wintertime.

(1) Lynch, and Hack, p.203, 1984.

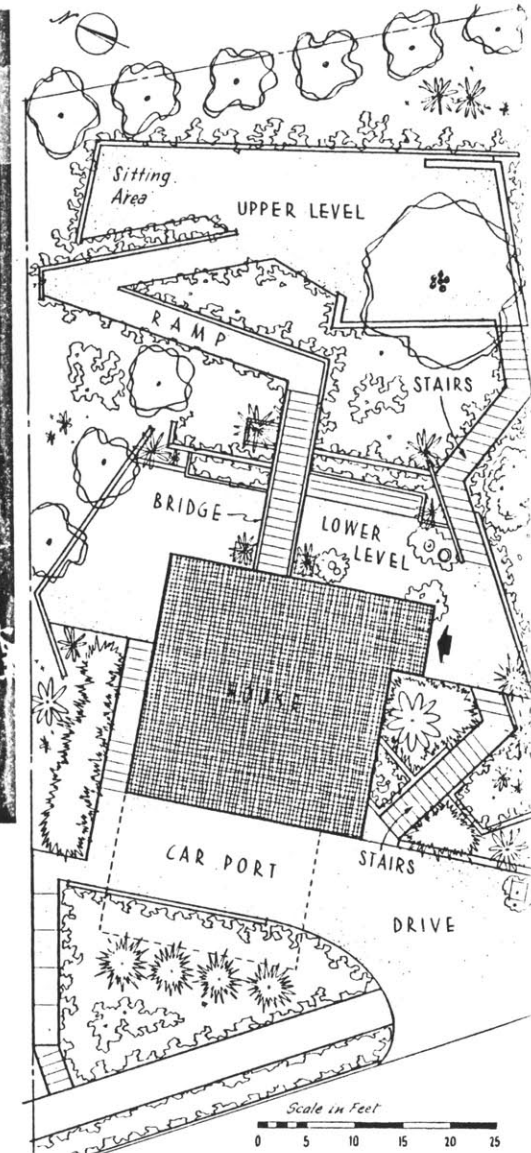
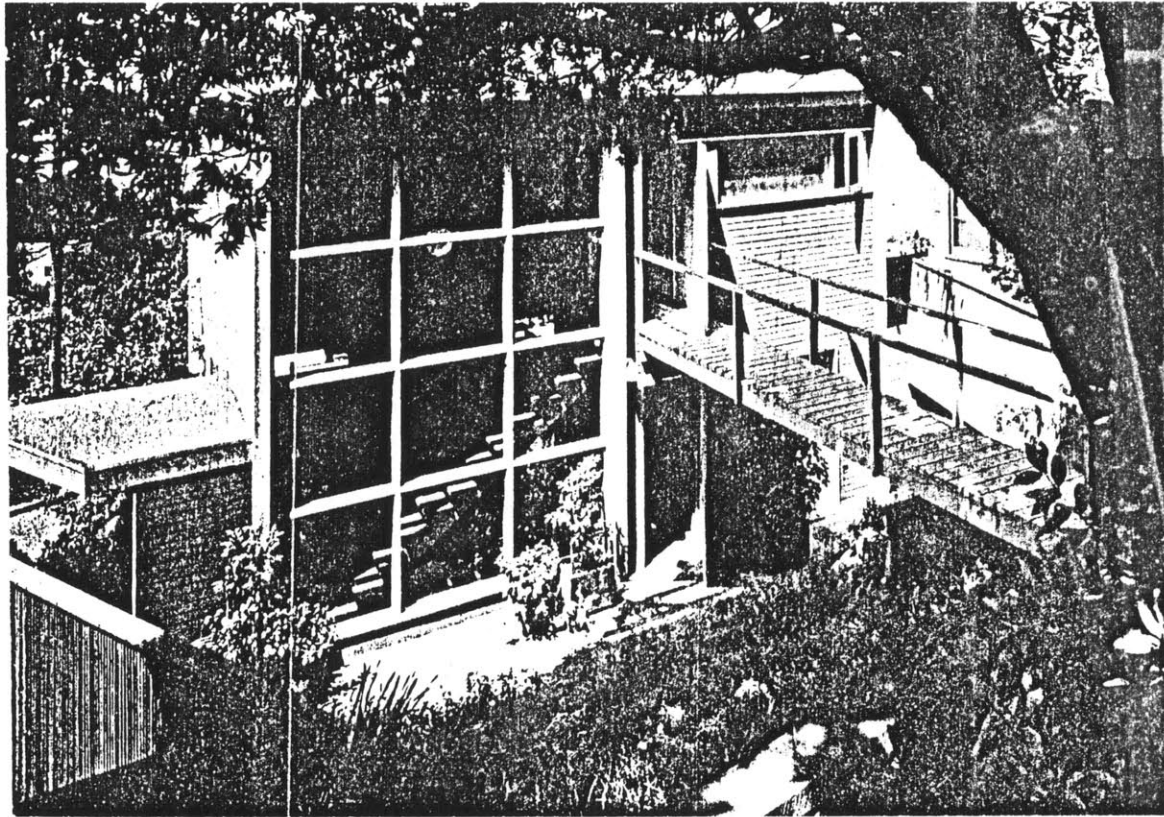

Figure 80. Bridge to uphill terraces.
 Arch: Henry Hill
 (Sunset Ideas for Hillside Homes,
 p.36-37, 1961)

PRIVATE SPACE

On slopes steeper than 20° it becomes expensive and difficult to have outdoor space which is terraced into the hill. Much of the outdoor space may be in the form of balconies, decks, and platforms. Combining decks with small terraces gives adults access to the hill for gardening and landscaping, and will provide children with a wider range of play surfaces. Children will quickly get bored playing on a deck and will want to get out to roam the hillside.

Freestanding buildings uphill of the road will have two sloping side edges and one uphill edge for private use. Using the house to build a flat uphill space will allow access to the hill for future gardening and landscaping. The need for

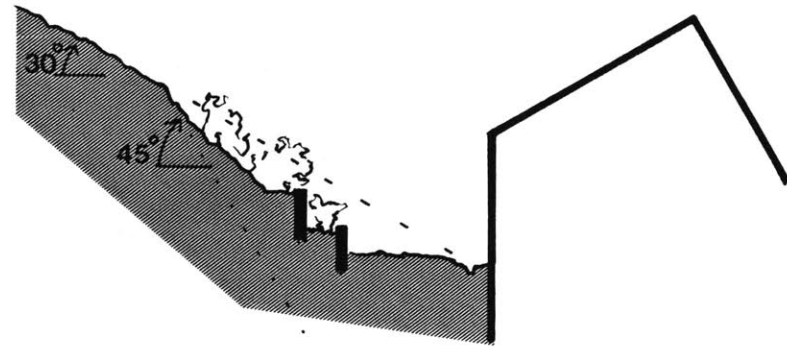

Figure 79. Private space uphill of houses. Disturbed ground provides opportunity to build terraces uphill of the house.

backfilling uphill of the house may provide an opportunity for creating a flat terrace since the ground has already been disturbed. Figure 79. If an oblique space is necessary to allow light in, a bridge can connect the house to uphill decks and terraces. Figure 80. Spaces uphill of the house will be very private due to their remoteness from the street.

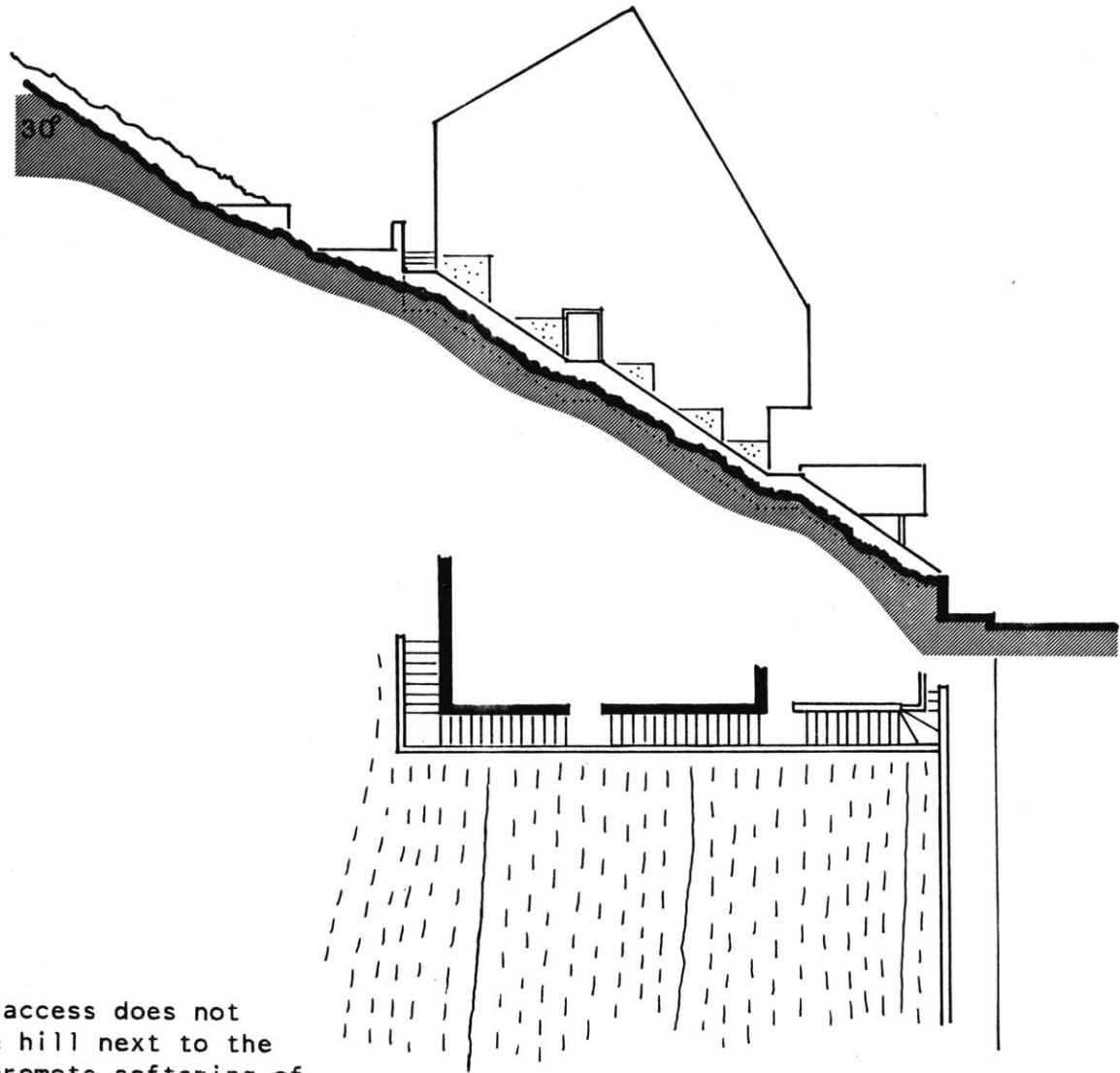

Figure 81. A singular uphill access does not promote use of the hill next to the house. Does not promote softening of the house-hill union over time. Cannot be prepared in sections if decay occurs. Evenly spaced contours are erosion prone.

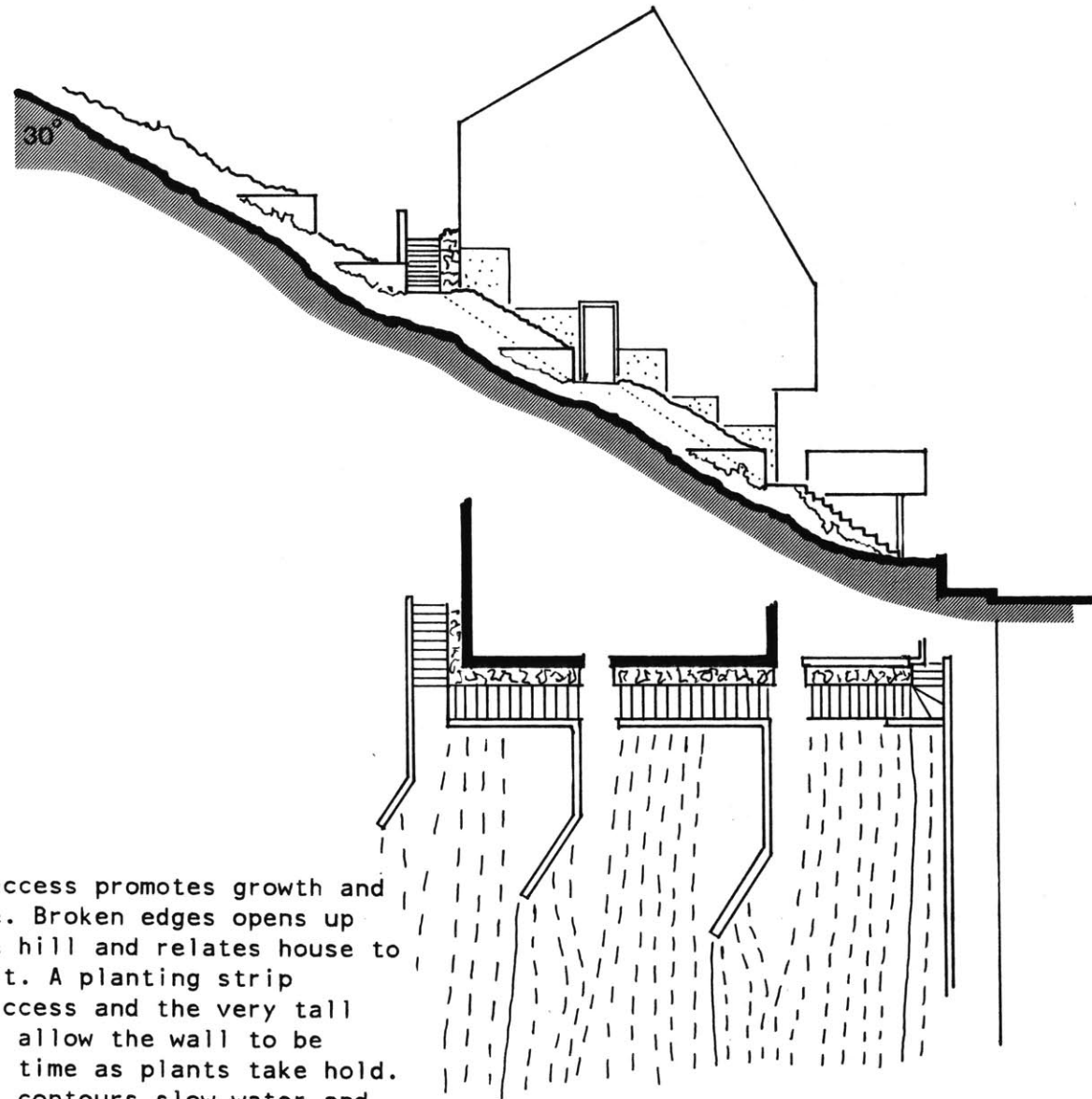
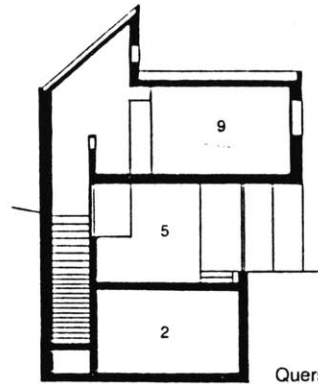
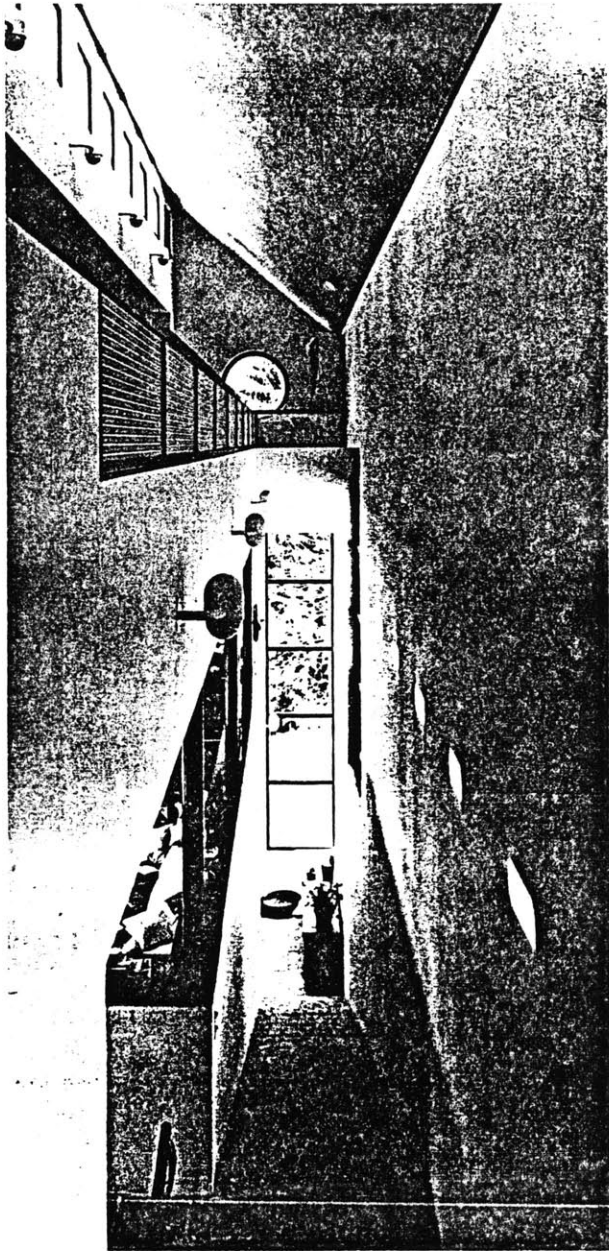
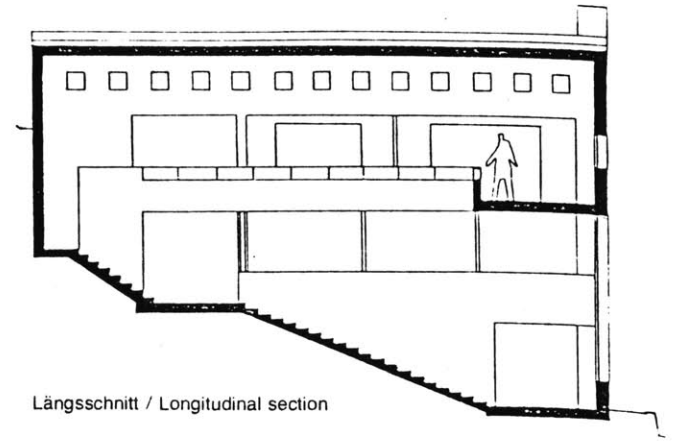

Figure 82. This uphill access promotes growth and use over time. Broken edges opens up access to the hill and relates house to land beside it. A planting strip between the access and the very tall end wall will allow the wall to be softened over time as plants take hold. Variations in contours slow water and discourage erosion.



Querschnitt



Längsschnitt / Longitudinal section

Figure 83. Uphill - downhill access serves as an organizer for this house.
Arch: Luigi Snozzi, Tessin, Switzerland
(Wolff, p.92, 1975)

The spaces beside and between houses can also be used and developed as attractive green space, and should not be forgotten. It also may provide access to the uphill side of the house. A singular approach to these edges transverse to the contours may not promote use of the hill, nor will it promote softening of the hill-house union over time. Figure 81. Smooth continuous slopes may promote erosion. Figure 82 illustrates possibilities for opening up to the hill. Small retaining walls are used to create some landform and access, which might lead to a future deck. Variations in contour will slow overland water flow and discourage erosion. Planting space next to the house allows for future softening of the hill-house edge.

Houses which are downhill from the

road on slopes steeper than 20° will need to have a larger amount of constructed outdoor space than houses uphill of the access. Constructed outdoor space, such as decks which can be suspended above the ground, reduce the need to walk all the way down to ground level to relax. This is more desirable for adults than for children. Children generally prefer to run freely in, out, and around the house. Houses disassociated from the ground don't promote the required inside-outside continuities.

In buildings where stair access to the downhill is desired, the stair can become an important architectural event. In this house by Architect Luigi Snozzi located in Tessin, Switzerland, the stairwell acts as an organizer and a light source. Figure 83.

CONCLUSIONS

The natural forces at work on a hillside; rain, gravity, wind, and others, are slow, powerful, and by nature inexorable. Man's intrusion into this play of forces can easily catalyze and accelerate the collapsing process of hillsides. (1) Understanding the geology of the hill, and working in a way which takes advantage of and/or works with the properties of the soil is a minimum start to building sensibly on a hillside.

By their nature hills are more difficult and more expensive to build on than level ground. They are geologically less stable than level ground. They are in a perpetual state of slowly falling

(1) Geology in Environmental Planning, p.16, 1978

down, be it through the rapid collapse of a landslide, a slowly creeping soil, or the imperceptible chemical weathering of subterranean rocks. They have been falling down for millennia, so that what remains of them is by default relatively stable. They will remain in good shape if left alone. The less the slope is changed, the fewer problems will arise. The retention of natural topographic features is an important principle. These include swales, streams, slopes, ridge lines, rock-outcroppings, vistas, natural plant formations, and trees. (1) Disregarding these features is likely to result in trouble inherited by future occupants.

There is a wide range of elements to

(1) Duncan and Jones, 1969

use in building landscape; concrete walls, dry laid stone walls, rock gardens, plantings and many more. Using a variety of elements makes it easier to add, change, or repair the landscape in the future. The landscaping can thus be more responsive to the hill over time, as opposed to a system where every form is rigid, like reinforced concrete for example. It is inherently difficult to hold the hill in one exact place, unless it is solid rock. Interventions which can accomodate the changing nature of a hillside will last longer.

An important part of minimizing slope damage is considering how the project will be built. Keeping major equipment completely off steep slopes is the best solution if possible. This means using pumper trucks to deliver concrete to the

site so that the large heavy mix-trucks are kept at a distance. Excavating and backfilling is best done by hand, or at least with a minimum of equipment. Equipment with long arms or booms may be especially useful. On bigger projects, carefulness of the slope may tend to get lost in the shuffle. Erosion control during the construction process and preservation of vegetation should not be overlooked.

The foundation is strongly determined by the geology of the site. The type of foundation chosen to do the job may greatly influence the building system chosen by the Architect. On a hill, more of the foundation will be evident, so the Architect must work harder to understand the foundation system and thereby keep it under control.

Some foundations are built into the hill and must respect the nature of the hill and must respect the nature of the hill. These foundations are generally used on shallow and moderate slopes, up to 20°. On the steeper slopes, in excess of 20°, structures which are disassociated from the hillside are generally more suitable. Pole structures and Pier and Grade Beam foundations will have the smallest impacts on a slope. The other methods are not ruled out immediately, but their use on steeper slopes is best when reconsidered from the point of view of minimizing changes to the slope. This means that the design is best tailored to the slope, and tailoring of the slope minimized. A result of disassociating the structure from the hill is that the building may become disassociated from anything that one associates with home or

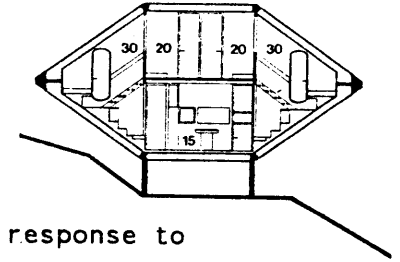

Figure 84. Disassociated form, a response to freezing climate.
Arch: Maurice Hindie, Faraya, France
(Wolgensinger, p.42, 1981)

ground. Figure 84.

There is a way to build upon almost any hillside, but the greater the difficulty, the greater the cost will be. Some situations will be best left alone. Knowing how to build a project may be the same as knowing not to. In the drive to determine how to accomplish the goal, it is easily forgotten that one has the option of not doing it at all, or perhaps doing it in another way, or on a different site. The desire to build on slopes and preserve the natural landscape is rife with internal conflict. Building on the steeper slopes, 20°+, must be done minimally with lots of care.

APPENDICES

FOUNDATION TYPES

The available building systems for hillsides begin with the foundations, which are specified and designed by the geotechnical engineer. Foundations fall into two basic types, deep and shallow. The use of a deep foundation indicates that the surface ground provides insufficient bearing to support the weight of the building. The foundation reaches down into the ground to provide bearing. Shallow foundations indicate competent bearing is available at the surface.

SYSTEMS USING SHALLOW FOUNDATIONS:

CONVENTIONAL FOUNDATION: STEM WALL WITH SPREAD FOOTINGS

The stem wall with spread footings is the most common foundation system in use in this country. This system can be used to create flat buildable places on hillsides through a process of cut, fill, or cut and fill. The spread footing distributes the weight of the structure on the soil. Its' size depends on the weight of the building and the competency of the soil to bear that weight. Typical dimensions for a spread footing in residential construction, on good bearing soil, is 8" high by 16" wide. Typically in New England, the frost line extends to a depth of about four feet down. The

spread footing must be placed below the frost line or else the foundation will heave. In New England, the stem wall is often referred to as the frost wall.

To install a spread footing a trench about 4' wide and 5' deep must be excavated. This is a large amount of excavation and on a hillside this can become a serious erosion problem both during and after the construction phase. This type of foundation is expensive due to the difficulty of excavating on slopes. Temporary and permanent retaining walls may be required. Retaining walls should extend through filled areas so footings can rest on undisturbed soil. (1)

(1) Sunset Ideas for Hillside Homes, p.10, 1961.

STEPPED FOUNDATIONS

On a hillside, it may be necessary to step the footing to accomodate the slope. This system is standardly used on stable soils with a slope of between 2 in 10 and about 5 in 10. (1) The steps in the footings should generally be limited to drops of 2 ft. This helps prevent horizontal shearing of the stem wall. Larger vertical drops can be used, but they will require stiffer, bigger, and thus more expensive stem walls. The stepped footing approximates the contour of the slope. In climates where freezing is not a problem, stepped footings do relatively little damage to the hill, primarily because they require limited

(1) Spexarth, p.63, 1983, F.H.B. #26

excavation.

The top of the stem wall can be either horizontal, or step down with the footing. If the stem wall steps down, a secondary system such as wood studs is used to make up the difference to the horizontal.

MODULAR STEPPED FOUNDATION WITH A MODIFIED SPREAD FOOTING

The best description of this system is that of Michael Spexarth. (1) Spexarth, a contractor in California, simplifies the construction of the stepped footing by using modular forms. The forms have two degrees of freedom, which allow them to conform easily to changes in

contour. They can slip vertically for shallow contour changes, or horizontally for large contour changes. Figure 85. Spexarth prefers to use 2 ft. by 8 ft. panels. He works in a climate where there is no freezing. In New England larger panels would be necessary to reach below the frost line.

The spread footing and stem wall are poured monolithically in this system. This is a modification of the conventional system. The resulting inverted T shape foundation wall is stiffer than if stem wall and footing are poured sequentially. This system has several basic improvements over other stepped footings. The modular forms allow greater flexibility in building the formwork to follow the contours of the hill, thus reducing excavation. The use of a modified spread

(1) Fine Homebuilding #26, p. 63-65, 1985

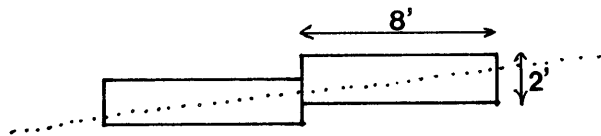

VERTICAL SLIPPING
shallow contour changes

Figure 85. Use of formwork components in modular stepped footings to negotiate grade changes.

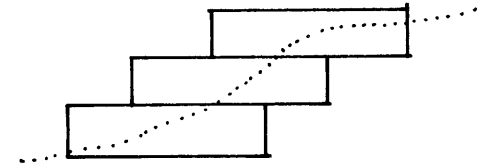

HORIZONTAL SLIPPING
large contour changes

footing allows the entire foundation to be poured at one time, with these advantages; the concrete trucks only come once, the monolithically poured foundation is stiffer than a conventionally poured foundation, and the fussy work of building a formwork to fit a complicated footing is avoided.

SYSTEMS USING DEEP FOUNDATIONS:

PILES, POLES, PIERS

Deep foundations come in two basic types, friction types and deep bearing. The friction type rely on friction forces between the piling and the soil to provide adequate bearing for the weight of the building. The deep bearing type uses the length of the piling to reach competent bearing stratum.

Piles are generally driven to the required depth. This process may engender instability in some hillside geologic formations due to the vibrations caused by pile driving. (Some soils will be improved by this process but generally not on hills.) Piles which are set in dug or drilled holes are called poles. Piers are

poured in place concrete.

The extra fill generated on site due to drilling is considerably less than the the mounds generated from digging the trenches for a conventional foundation. The extra fill must still be properly dealt with. Drilling, or digging, individual holes does much less damage to tree roots and natural drainage routes than trenching for a conventional foundation. (1)

POLE FOUNDATIONS

A pole foundation is probably the least expensive method for a hillside application, although it still costs more than a conventional foundation built on

(1) Miller, C., FHB #15, p.27, 1983.

level ground. (1) Poles offer great flexibility for building on hills. They can negotiate slopes at least as steep as 10 in 10 (45 degrees). There is much freedom in the vertical dimension. Using poles, a horizontal platform can be easily established, relatively independent of steepness of slope. The elevations of the floor levels can be adjusted, simply by attaching the crossbeams higher or lower. A large number of different levels can be established. Cantilevering the main crossbeams provides options for more living space and/or outdoor decks. The walls are not load bearing in this system, though some shear resistance must be built

in to them in order to resist wind loads.

(1)

Poles come in a variety of types, concrete, steel, but wood is by far the most common. Poles can be set on piers, poured in place with concrete, set on footings placed below ground, or set directly in the ground. (Precautions must be taken to discourage rot.) Another advantage of a pole foundation is that it is mechanically flexible, and thus can accomodate some settling. It is quite possible that a pole foundation can be designed to allow adjustment of floor levels, should settling prove to be too uneven.

(1) Hillside Homes, p.11, 1961.

(1) Moore, T.B., FHB #15, p.32-33, 1983.

PIER AND GRADE BEAM FOUNDATION

- "This type of foundation links a poured concrete perimeter footing to the ground with a matrix of grade beams and concrete piers, some up to 20 ft. in depth. The resulting grid grips the hillside like the roots of a giant tree. Slopes in excess of 45 degrees can be built on with this kind of foundation. And in areas where there are landslides, expansive soils or earthquakes, a pier and grade beam foundation may be required by local building code.

As a rule pier and grade beam foundations need more reinforcing steel than conventional foundations, and require special concrete mixes. On the other hand, they usually call for less formwork

than perimeter foundations do." (1) This type of foundation is not level, but approximates the contours of the hill. A secondary system is used to make the transition to the horizontal as with a stepped foundation. The holes for the piers must be drilled. This system is used primarily in California.

Truck mounted drill rigs can operate on slopes up to 30 degrees and do less damage to the slopes than the tractor or crawler mounted auger which can operate on a slope up to 45°. Downslope sites are less difficult than upslope sites. Drill rigs can commonly require as much as 30' of overhead space for operating. This may necessitate the trimming and/or removal of some trees. Spexarth's rule of thumb is that a foundation on a downslope will cost

(1) Michael Spexarth, FHB #16, p.35, 1983.

twice as much as a foundation on level ground and an upslope site will cost three times as much. Spexarth also warns that drilling produces a lot of extra soil which must be either removed or stabilized.

In a freezing climate space must be left between the grade beam and the ground to prevent frost heave. The use of a grade beam makes the foundation compatible with a system of bearing walls, or point loads over the piers.

HOUSING TYPES



Housing Types are presented in order of increasing density. Since this corresponds to a decreasing angle of slope incline, one can assume that density goes down as slope angles get steeper. These housing types are presented as part of an exploration of how existing housing types can be used on hillsides. Systems using elevators do not substantially increase density because density is more directly limited by parking. (This assumes a parking ratio of 2.0.) At the toe of a hill, or on slopes under maybe 15°, structured parking will substantially increase density.

Figure 86.

Maximum density with building pads.
TYPE: detached
SLOPE: 0°- 30°
PARKING RATIO: 2.0
DENSITY: 12 d.u./acre (net)
OWNERSHIP: fee simple

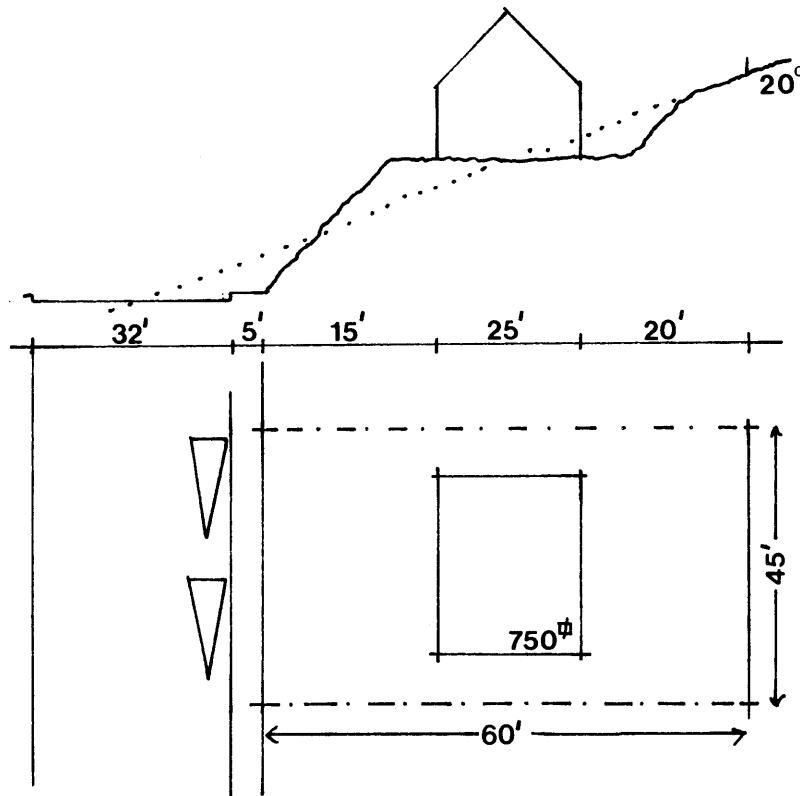

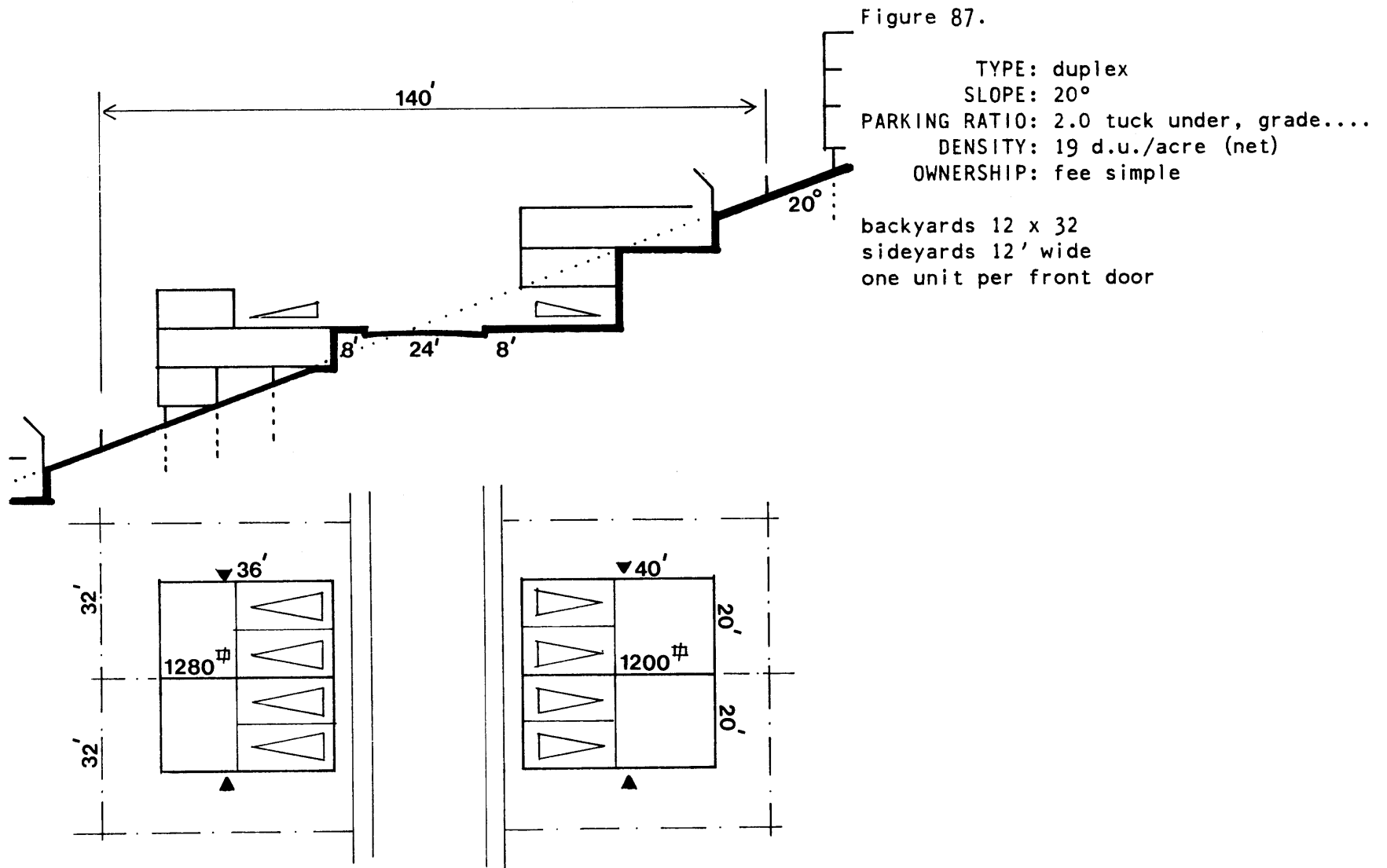
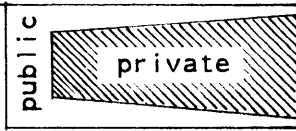
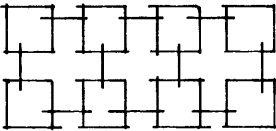
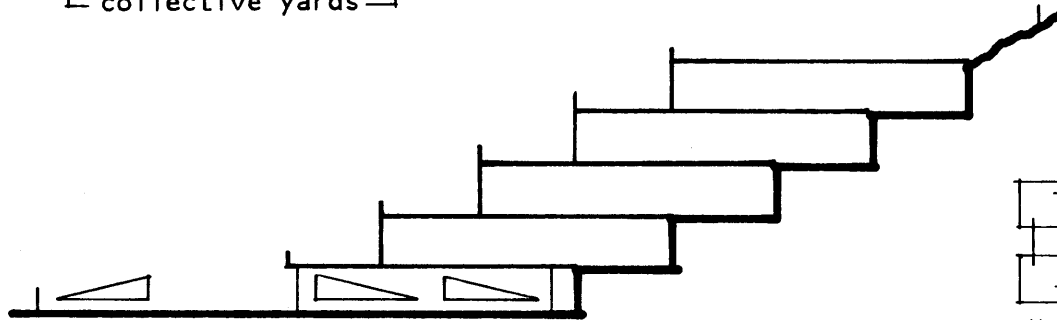
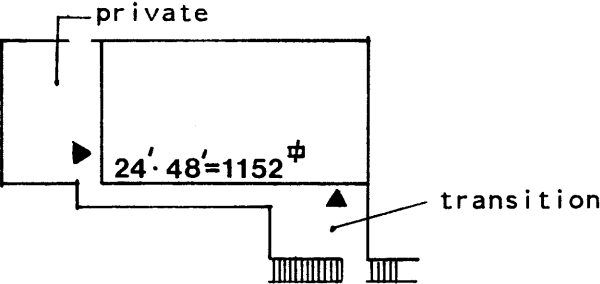
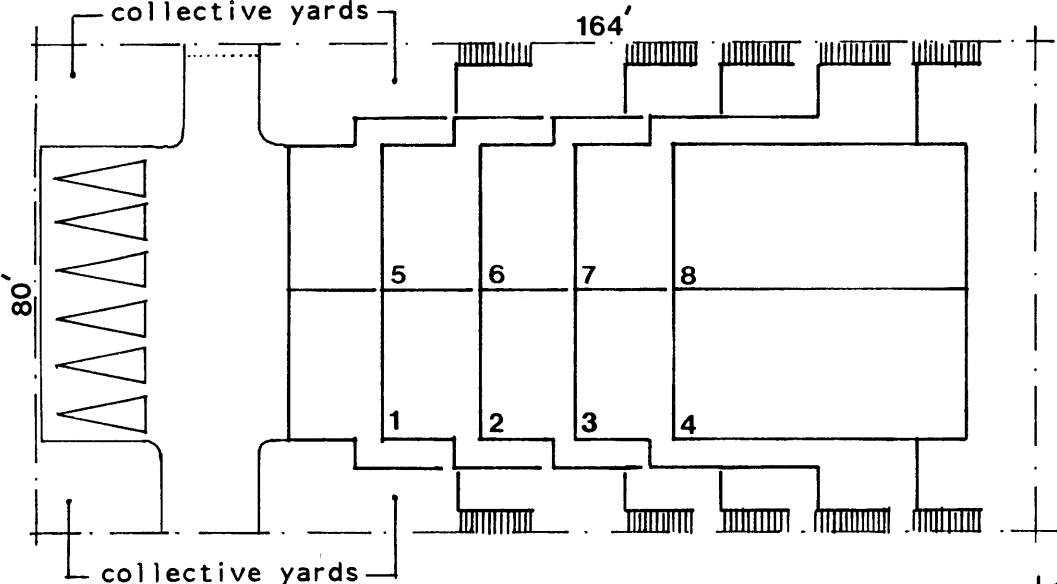
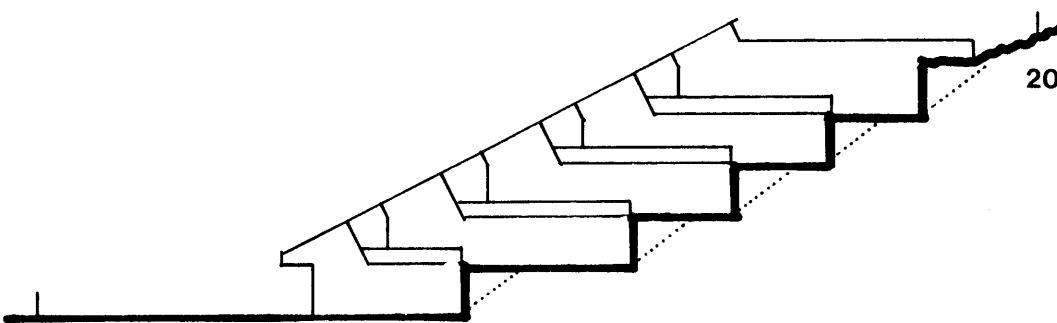

Figure 88.

TYPE: Terracehousing
SLOPE: 20°
PARKING RATIO: 2.0
DENSITY: 26 d.u./acre (gross)
OWNERSHIP: association

2 lit edges each unit
2 outdoor areas each unit
4 flights walk up max.
community space provided



Neighbor pairs

Figure 89.

TYPE: rowhouse
SLOPE: 30°
PARKING RATIO: 2.0
DENSITY: 26 d.u./acre (net)
OWNERSHIP:

backyards 12 x 32
one unit per front door

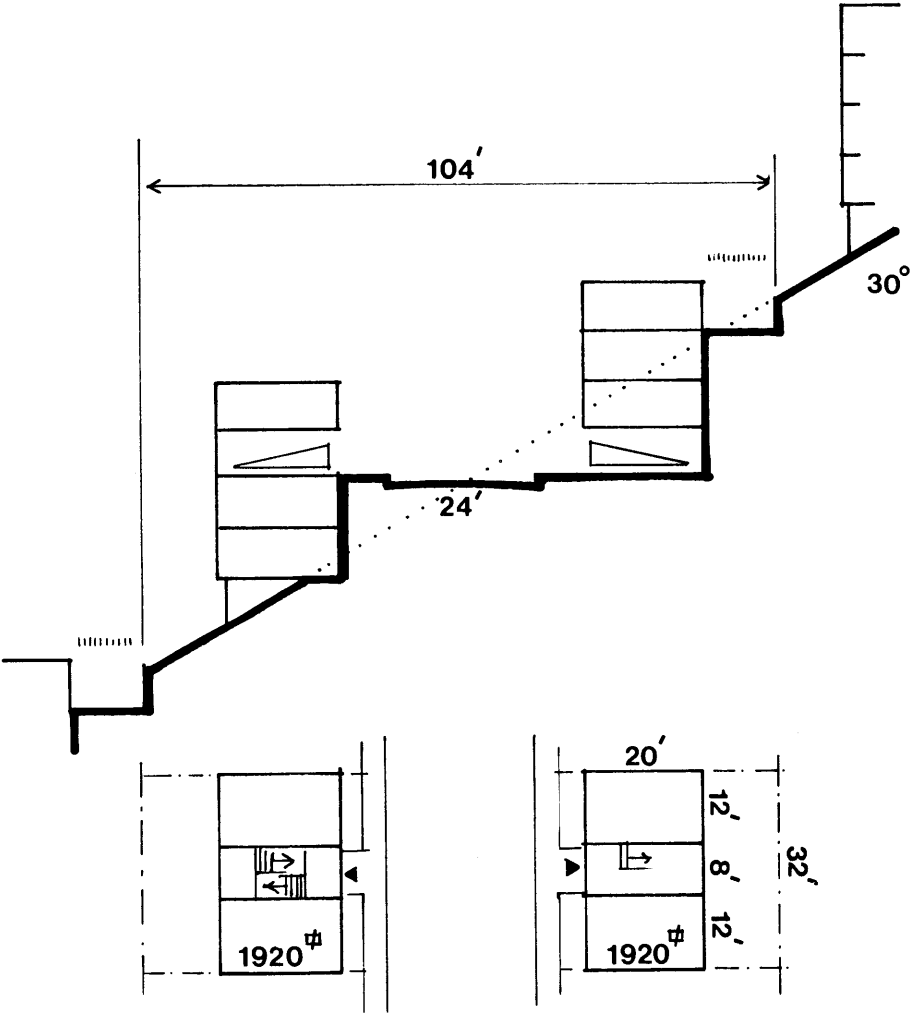

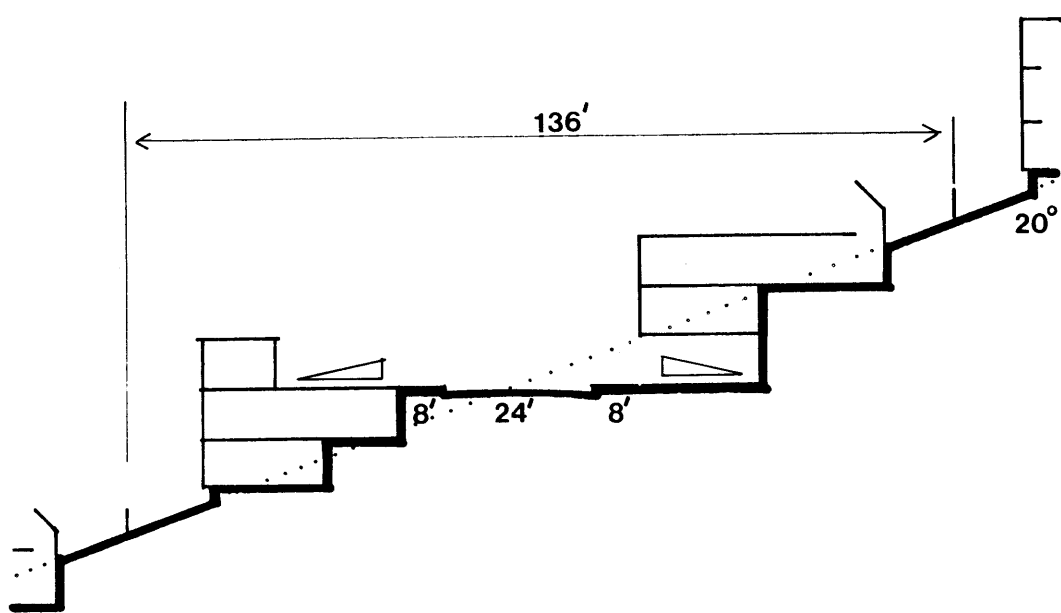

Figure 90.

TYPE: rowhouse
 SLOPE: 20°
 PARKING RATIO: 2.0
 DENSITY: 27 d.u./acre (net)
 OWNERSHIP: fee simple

backyards 12 x 24
 one unit per front door
 lots 24 x 48, 24 x 56

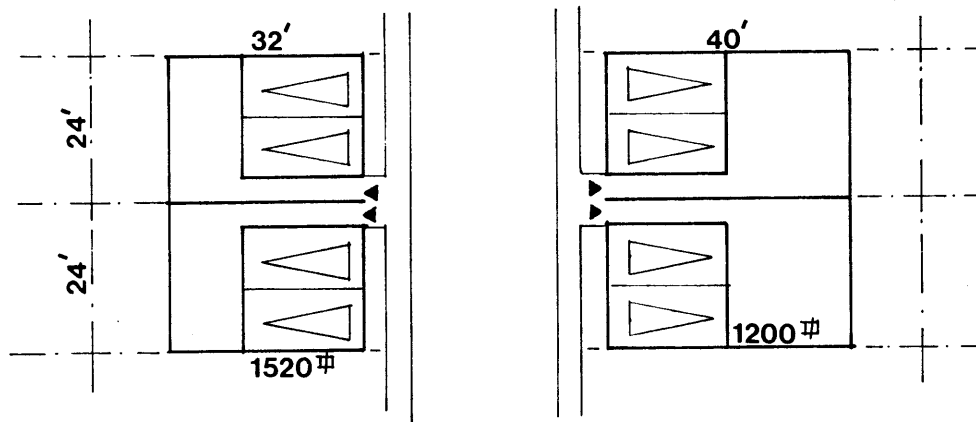

Figure 91.

TYPE: rowhouse
SLOPE: 10°
PARKING RATIO: 2.0 two car lifo, garage
DENSITY: 33 d.u./acre (net)
OWNERSHIP: fee simple

backyards 16 x 20
one garage could be swing space

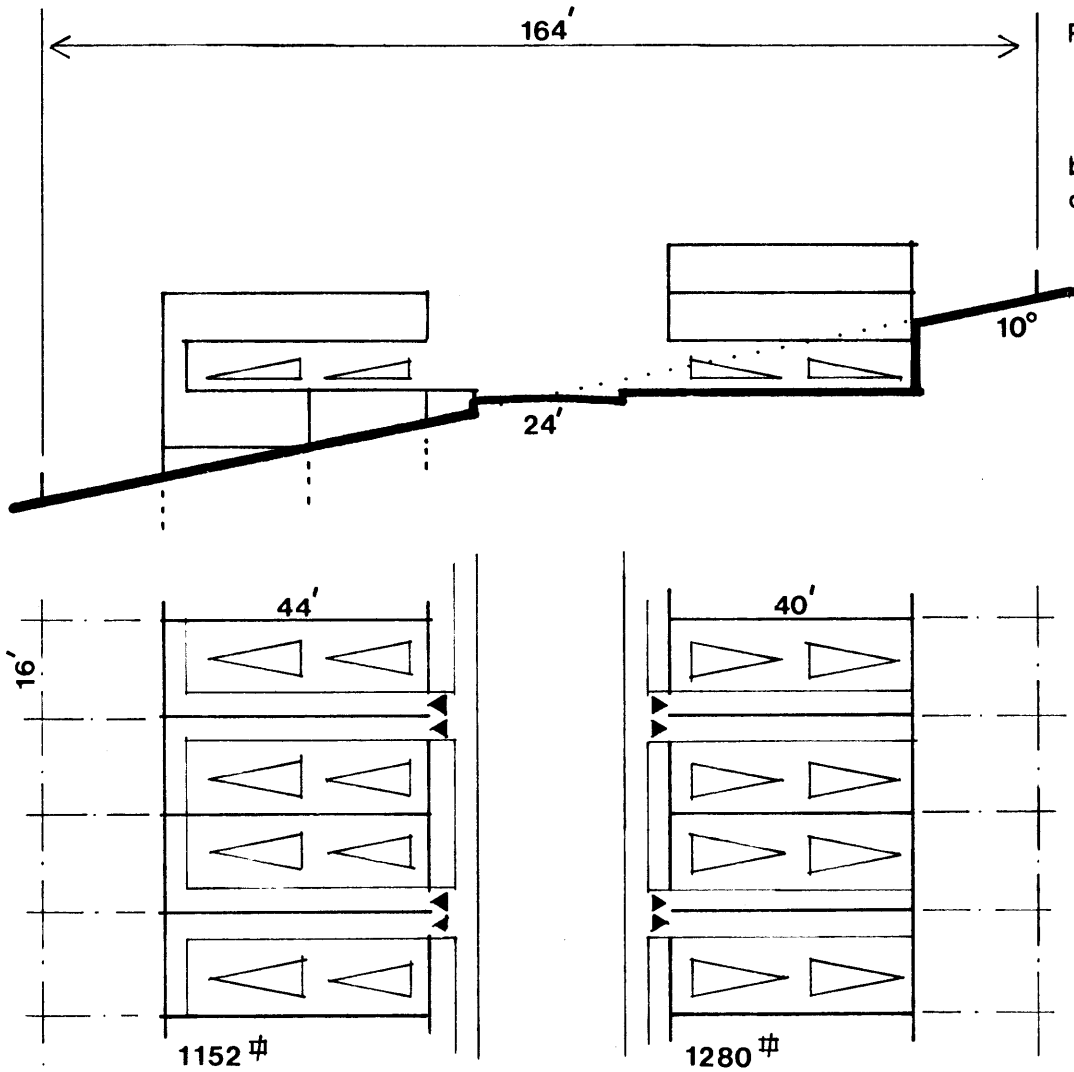
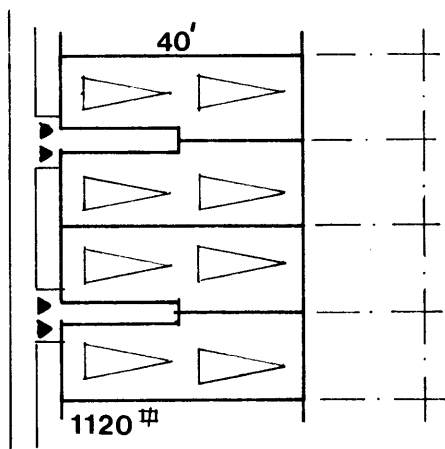
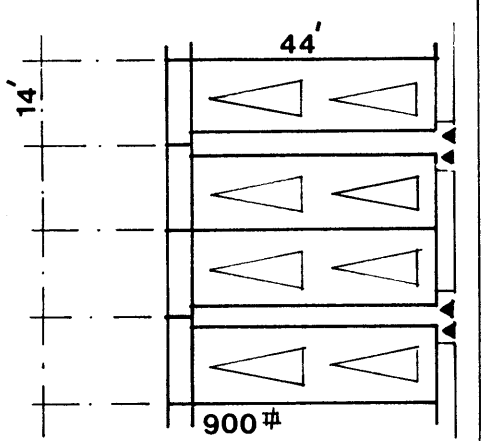
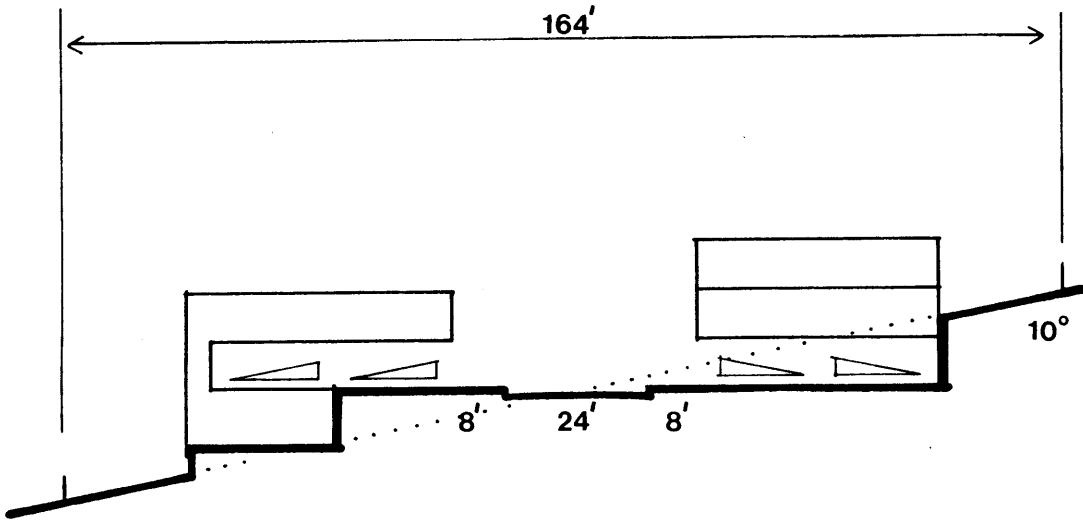

Figure 92.

TYPE: rowhouse
SLOPE: 10°
PARKING RATIO: 2.0
DENSITY: 38 d.u./acre (net)
OWNERSHIP: fee simple

backyards 14 x 20
two units per front door
one garage could be swing space



BIBLIOGRAPHY

Abbott, D. and Pollit, K., HILL HOUSING, A COMPARATIVE STUDY, Granada Publishing Ltd. 1980

Ando, T., BUILDINGS PROJECTS WRITINGS, Rizzoli, N.Y., 1984

Barr, R. J., "Foundations on Hillside Sites", Fine Homebuilding #16, The Taunton Press, Cn., 1983

Bell, F. G., editor, FOUNDATION ENGINEERING IN DIFFICULT GROUND, Butterworth and Co. Ltd., 1978

Benkert, K., TERRASSENHAUSER AM HANG, Deutsche Verlags - Anstalt, Stuttgart, 1974

Bowles, J. E., FOUNDATION ANALYSIS AND DESIGN, McGraw - Hill, Inc., 1977

Bring, M., and Wayemburgh, J., JAPANESE GARDENS DESIGN AND MEANING, McGraw - Hill, Inc., 1981

Bronson, W., HOW TO KILL A GOLDEN STATE, Doubleday and Co. Inc., N.Y., 1968

Carver, N. F., ITALIAN HILLTOWNS, Documan Press Ltd., Kalamazoo, Mich., 1979

Carver, N. F., IBERIAN VILLAGES, Documan Press Ltd., Kalamazoo, Mich., 1979

Chewning, J. A., HILLSIDE STUDIES AND LEGISLATION ACROSS THE UNITED STATES, The Cincinatti Institute, Cincinatti, Ohio, 1974

Clark, Frederick P., Associates, VILLAGE OF ROSLYN HILLSIDE DEVELOPMENT, Planning Consultants, Rye, N.Y., 1972

Drexler, A., and Hines, T.S., THE ARCHITECTURE OF ROBERT NEUTRA, The Museum of Modern Art, N.Y., 1982

Duncan and Jones, HILLSIDE DEVELOPMENT POLICIES: PACIFICA CALIFORNIA, prepared by Duncan and Jones, Urban Planning and Design Consultants, Berkeley, Cal., 1969

Eckel, E. B., ed.: "Landslides and Engineering Practice", Highway Research Board Special Report. #29, NAS-NRC Publ. 544, National Academy of Sciences, Washington, D.C., 1958

Gebhard, D., SCHINDLER, The Viking Press., N.Y., 1972

Giamportone, K. F., INHABITING THE HILLSIDE: PROJECTIONS / PROCESS, M.I.T., M.Arch. Thesis, 1984

Gruen, Victor, Associates, VERDE VILLAGE: CONSTRUCTION METHODS, 1965

Howard, A. D., and Remson, I., GEOLOGY IN ENVIRONMENTAL PLANNING, McGraw - Hill Book Co. Inc., U.S.A., 1978

Jackson, J.B., "Nearer Than Eden". in the collection THE NECESSITY FOR RUINS AND OTHER TOPICS, 1980

Keith and Associates, HILLSIDE POLICY: CITY OF BREA., Brea, Cal., 1975

Kovacs, W. D., and Yokel, F. Y., "Soils and Rock Anchors for Mobile Homes. A State-of-the-Art Report". U.S. Dept. of Commerce. National Bureau of Standards. Building Science Series 107, Oct. 1979

Lobeck, A. K., GEOMORPHOLOGY: AN INTRODUCTION TO THE STUDY OF LANDSCAPES, McGraw - Hill Book Co. Inc., N.Y. and London, 1939

Lynch, K. and Hack, G., SITE PLANNING, The M.I.T. Press, Cambridge, Ma., 1984

Marsh, W. M., LANDSCAPE PLANNING, ENVIRONMENTAL APPLICATIONS, Addison Wesley Inc., Reading, Ma., 1983

McCOY, E., FIVE CALIFORNIA ARCHITECTS, Reinhold Publ. Corp.,
N.Y., 1960

Merrilees, D., and Loveday, E., Revision by Wolfe, R., LOW - COST
POLE BUILDING CONSTRUCTION, Garden Way Publishing, Charlotte,
Vt., 1980

Miller, C., "Steep - Site Solution", Fine Homebuilding #15, The
Taunton Press, Newtown, Ct., 1983

Moore, T. B., "Pole House in the Treetops", Fine Homebuilding
#15, Taunton Press, Newtown, Ct., 1983

Nattel, G. M., THE CLASSIFICATION AND ANALYSIS OF TERRACE HOUSES
AND THE RATIONALIZATION OF THEIR DESIGN PROCESS, M.I.T., M. Arch.
A.S. Thesis, 1979

Riccabona, C. and Wachberger, M., TERRASSENHAUSER, (Entwurf und
Planung #14) Munchen, 1972

Simson, B. J., and Purdy, M. T., HOUSING ON SLOPING SITES: A
DESIGN GUIDE, Construction Press, N.Y., 1984

Spexarth, M., "Pier and Grade Beam Foundation", Fine Homebuilding
#16, The Taunton Press, Newtown, Ct., 1983

Spexarth, M., "Stepped Foundations", Fine Homebuilding #26, The
Taunton Press, Newtown, Ct., 1985

Sung, A., ON THE EDGE, M.I.T., M.Arch. Thesis, 1983

SUNSET IDEAS FOR HILLSIDE HOMES, ideas compiled from Sunset
Magazine, Lane Book Co., Menlo Park, Cal., fourth printing, 1961

Wolff, R., HAUSER AM HANG, Verlag Georg. D. W., Callwey, Munchen,
1975

Wolgensinger, B., HAUSER IN DEN BERGEN, Wasmuth, Tubingen, 1981

Woodbury, R. B. in Hodge, C., and Duisberg, P., eds., "Aridity and Man", American Association for the Advancement of Science, Publ. #74, 1963

Zalewski, W., BUILDING ON SLOPES: AN APPROACH, M.I.T., 1970