

AN AQUARIUM FOR BOSTON

by

DONALD S.C. TSAO

B. Arch., University of Hong Kong

(1958)

SUBMITTED IN PARTIAL FULFILLMENT OF THE REQUIREMENTS  
FOR THE DEGREE OF MASTER OF ARCHITECTURE AT THE  
MASSACHUSETTS INSTITUTE OF TECHNOLOGY, MAY 1960

Signature of Author .....

Department of Architecture, May 9, 1960

Accepted by .....

Chairman, Departmental Committee on Graduate Students

314 Harvard Street  
Cambridge 39  
Massachusetts  
May 9, 1960

Dean Pietro Belluschi  
School of Architecture and Planning  
Massachusetts Institute of Technology  
Cambridge 39  
Massachusetts

Dear Dean Belluschi:

In partial fulfillment of the requirements for the degree of Master of Architecture, I would like to submit my thesis entitled " An Aquarium for Boston " .

Respectfully,

-----  
Donald S.C. Tsao

## ACKNOWLEDGEMENTS

I would like to take this opportunity to express my sincere gratitude to those who have given me help in preparing this thesis, especially those at the Department's Thesis Committee:

Dean Pietro Belluschi

Prof. Lawrence B. Anderson

Prof. Herbert L. Beckwith

Prof. William H. Brown

and also to:

Dr. Christopher W. Coates, Curator, New York Aquarium

Mr. Harmon H. Goldstone, Architect of New York Aquarium

Mr. Walter D. Stone, Director, Franklin Park Zoological Gardens.

## THESIS ABSTRACT

- a. Title: AN AQUARIUM FOR BOSTON
- b. Name of Author: Donald S.C. Tsao, B.Arch., University of Hong Kong, 1958
- c. Submitted for the degree of Master of Architecture in the Department of Architecture on May 9, 1960

d. Abstract:

Boston at present has no public aquarium. The old Boston Aquarium operated by the City of Boston was closed down some four years ago. It was a free aquarium and the City could not meet the operating costs. The building was also old and inadequate. In keeping with Boston's being a centre for culture, education and recreation, a new aquarium is here proposed. Examples in other cities have shown that aquariums can be self-supporting by charging admissions. The new one will charge admissions and be operated by the Metropolitan District Commission of the Commonwealth of Massachusetts. The site chosen for the aquarium is located at Columbus Park, facing the Old Harbor of Dorchester Bay. The aquarium will exhibit a wide variety of species in fresh and salt waters maintained at different temperatures.

## TABLE OF CONTENTS

TITLE OF THESIS	i
LETTER OF SUBMITTAL	ii
ACKNOWLEDGEMENTS	iii
THESIS ABSTRACT	iv
TABLE OF CONTENTS	v
CHAPTER I GENERAL CONDITIONS	1
CHAPTER II SCOPE AND AIM	2
CHAPTER III DEFINITION & PURPOSE OF AN AQUARIUM	3
CHAPTER IV THE PARTS AND WORKING OF AN AQUARIUM	5
CHAPTER V THE OLD NEW YORK AQUARIUM	17
CHAPTER VI THE PROJECTED NEW YORK AQUARIUM	22
CHAPTER VII THE NEW YORK AQUARIUM	25
CHAPTER VIII THE LILY ACKERLAND FLEISCHMANN MEMORIAL AQUARIUM	29
CHAPTER IX THE STEINHART AQUARIUM	32
CHAPTER X THE VANCOUVER PUBLIC AQUARIUM	36
CHAPTER XI THE FRANKFURT EXOTARIUM	42
CHAPTER XII THE OPEN-AIR AQUARIUMS	53
A. THE MARINELAND, FLORIDA	53
B. THE MARINELAND OF THE PACIFIC	57
C. THE MIAMI SEAQUARIUM	61
CHAPTER XIII THE NAGASAKI AQUARIUM	65
CHAPTER XIV THE SITE FOR THE BOSTON AQUARIUM	73
CHAPTER XV THE PROGRAM FOR THE BOSTON AQUARIUM	76
CHAPTER XVI REPORT ON DESIGN	83
BIBLIOGRAPHY	xi
LETTERS	xiii

## CHAPTER I    GENERAL CONDITIONS

Boston at present has no public aquarium. The old Boston Aquarium operated by the City of Boston at Marine Park was closed down some four years ago. The City was not able to provide for the necessary running expenses of the Aquarium as it was a free aquarium and no admission was charged. The building itself was also old and inadequate, its location was not convenient for the public, and its neighborhood had been decaying.

In keeping with the City's being a centre for culture, education and recreation, a new aquarium for Boston is here proposed. Examples in other cities have shown that an aquarium can be self-supporting or meet most of its running expenses by charging admissions. The aquarium is to be operated by the Metropolitan District Commission of the Commonwealth of Massachusetts to serve the metropolitan area of Boston. Admissions will be charged. The Commission has under its operation at present, the Franklin Park Zoological Gardens.

## CHAPTER II SCOPE AND AIM

A thesis for a new aquarium for Boston was proposed by Henry A. Olko in 1953. It was for a small aquarium forming part of the Museum of Science at Science Park. Several examples of aquariums had been investigated. The present thesis is for a more independent aquarium with a more extensive coverage of species in a different and freer setting.

The complicated operation of an aquarium calling for its own research facilities and staff, the lack of building and parking spaces at the Science Park, and the time necessary for a visit fully appreciating the exhibits justify its being a separate establishment.

As new aquariums have been built since the last seven years, new examples as well as some others not previously investigated will be included.

By studying problems concerned with the design of aquariums and examples, the aim is to create an appropriate architectural conception for this building type and to provide materials for future reference.

### CHAPTER III DEFINITION AND PURPOSE OF AN AQUARIUM

An aquarium is a place where aquatic animal and plants are kept for exhibition and study or any other purpose. Anything, plant or animal, that lives wholly or partly in water can be fittingly displayed in an aquarium. The main exhibits in an aquarium are usually fishes.

In warm regions there are aquariums with large open air tanks filled with sea water having sometimes stadium seating around for visitors viewing shows performed by specially trained mammals; in cold regions almost all the tanks in an aquarium have to be kept indoors. In the second case the tanks are usually more numerous in number and smaller in size. The former resembles a circus and the latter, an indoor zoo or museum in character.

An individual tank is also referred to as an aquarium. New words "seaquarium" and "oceanarium" are coined to mean the large sea water tank or the building or structure containing such.

The purpose of an aquarium is manifold. To students, the



exhibits substitute direct observation for book knowledge. To the general public, it is a place of recreation as well as a source of knowledge. It is an attraction for tourists and a place for serious study and research for scientists. An aquarium sometimes helps to solve fishery problems and to keep specimens in an aquarium under the best possible condition requires research into their habits of feeding, diseases, and psychological behaviour.

An aquarium usually also publishes pamphlets and booklets of scientific or general informational interests.

## CHAPTER IV THE PARTS AND WORKING OF AN AQUARIUM

### a. Classification of Water

To keep a wide variety of aquatic specimens from various climatic regions of the world requires different kinds of water at different temperatures. Water is first classified as fresh or salt water. Within each kind it is then classified according to temperatures. It may be classified principally into warm, temperate or natural, and cold. The temperature of warm water varies from about 70°F to 80°F, temperate 45°F to 72°F and cold, 35°F to 50°F.

### b. Terminology of Tanks

Tanks containing specimens for direct exhibition to the public are termed exhibit tanks. They usually have a glass side facing the public. Reserve tanks are tanks in the service area behind the exhibit tanks for keeping exhibit specimens in reserve, sick specimens and food for the specimens.

Tanks in which the supply water is stored are termed as reservoirs or supply tanks. Gravity tanks refers to

tanks at higher level than the reserve and exhibit tanks to which they feed by gravity. Gravity tanks and reservoirs may sometimes be combined. Filter tanks are tanks with filtering materials.

### c. Water Circulation Systems

To ensure a healthy living condition for the specimens, the water used must be kept clean and maintained at the temperatures wanted.

In an open system water is pumped from the reservoir to the gravity tank which feeds water to the exhibit tanks and the reserve tanks. Water discharged from the exhibit tanks and the reserve tanks is drained away.

In a closed system the water discharged is not drained away but recirculated. The discharged water is passed through one or more filter tanks to the reservoir. Two types of filter tanks are generally used. One type filters away all undesired impurities in the water and the other contains coarser grained filtering material filters away larger particles of impurities only. The

remaining impurities are made to deposit in the reservoir by sedimentation. In the second case, two sets of reservoirs are needed for each separate system. While water is being supplied by one reservoir, the water in the other is made to deposit its impurities. Two sets of filter tanks are necessary. As one is being cleaned, the other is working to maintain a continuous circulation of the water.

The reservoir in the open system ensures a continuous supply of water in case of a supply failure, but it can be of much smaller capacity than one used in a closed system. In either system, a duplicate set of pumps is provided to meet the emergency of a breakdown of the other set.

For heating or cooling of the water, heating coils or cooling coils, or other heating or cooling equipments are introduced into the water circulation system.

For each kind of water, one system, whether open or closed is necessary, but usually more than one systems are used to limit water contamination in case of a

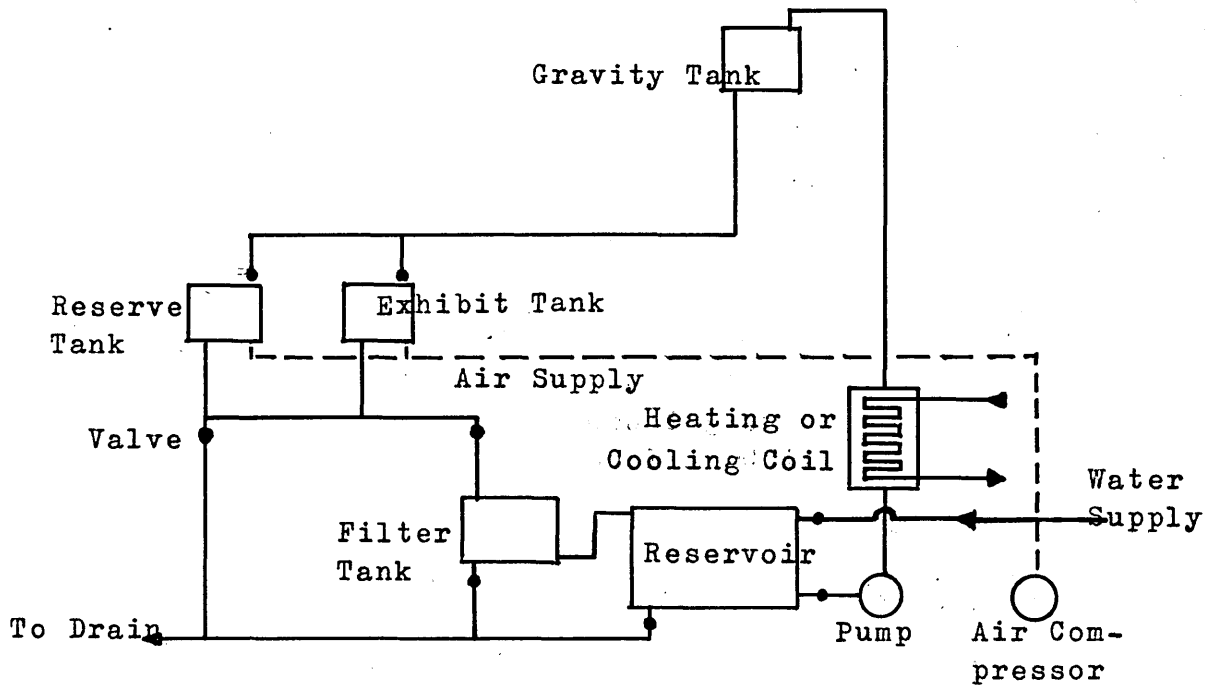

Diagram of a Closed System with Heating or Cooling

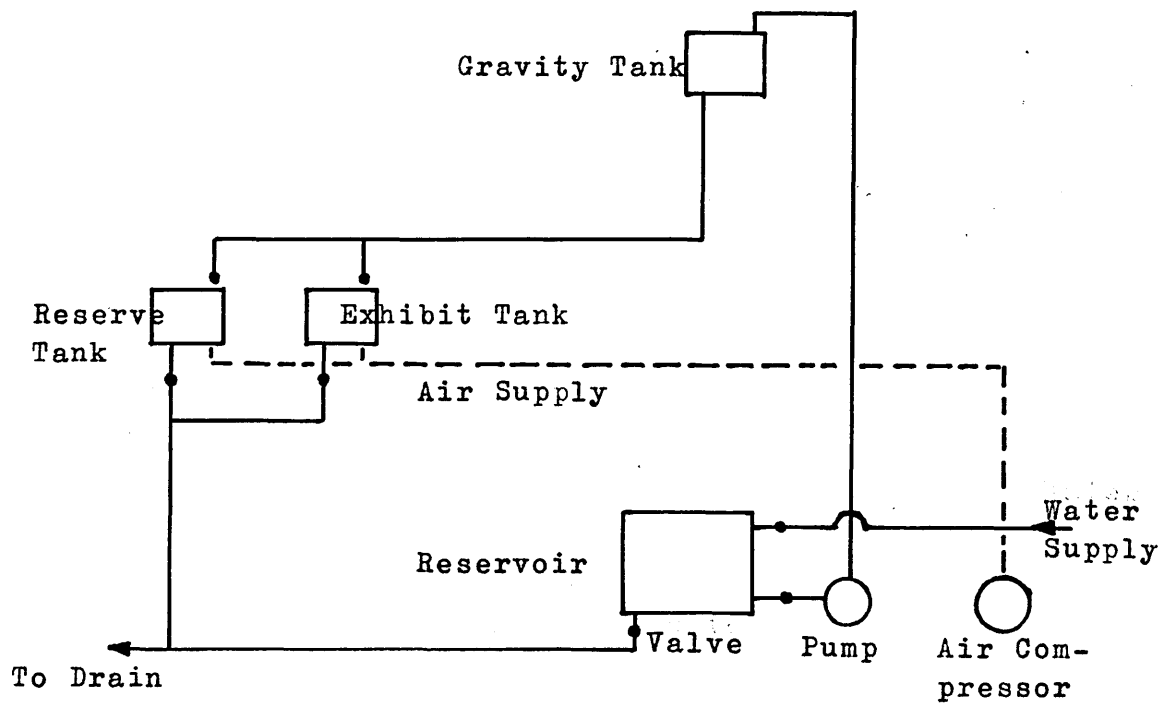

Diagram of an Open System without Heating or Cooling

specimen disease.

Small individual tanks of 10 to 20 gallons may have a small filtering system attached to it to form a complete water circuit in itself. Water in the tank is made to circulate through the filter by means of a supply of compressed air. A forced circulation is occasionally necessary by means of a pump. The time interval is usually several weeks, between forced circulations.

#### d. Water Aeration

In order for animal species to survive in the water, the water must have a supply of dissolved oxygen. To aerate the water, a current of compressed air is passed through it in the exhibit and reserve tanks, or the water is sprayed in fresh air at points in the water circulation system.

#### e. Balanced Aquaria

A balanced aquarium is a tank in which plant specimens are introduced to provide oxygen in the water for animal specimens. It has however been found that an aquarium can

never be really balanced.

#### f. Proportioning of Tanks

The ideal proportion between reserve tanks and exhibit tanks is believed to be one to one and that between the combined capacities of reserve tanks and exhibits and the revcoirs to be one to four. However as it is difficult and expensive to provide space for a large volume of water, a good practical standard is believed to be three to four for the former and one to one and a quarter for the latter.

#### g. Sources of Water Supply

Fresh water supply, besides from unpolluted natural sources, are usually taken from the city main. If the city water is chlorinated, the water must be passed through a dechlorination tank first. The best salt water supply is from areas of the sea where the water is unpolluted. Salt water can also be made from marine salt by adding fresh water to it, but it is expensive.

#### h. Water Data

Each cubic foot of water equals about 7.5 gallons and weighs 62.5 lbs. The critical angle of reflection is  $\sin^{-1} 1/1.33$  , from water to air.

#### i. Construction of Tanks

Large tanks are constructed of reinforced concrete while small ones up to about 4'x 4'x 5' have been made from painted masonite at the New York Aquarium. The tanks are framed by steel angles externally.

The bottom of exhibit and reserve tanks are usually covered with sand or gravel for fishes to rub their skin, besides giving a good appearance.

The viewing side of the exhibit tanks is usually double-glazed to avoid condensation. As water exerts a heavy pressure on the sides of a tank, the largest single piece of glass used with a head of water of about 5' behind it is only about 4' high x 6' wide and  $1\frac{1}{2}$ " thick. Laminated plate glass is preferred as it does not shatter suddenly.



The top of the exhibit tank is usually left open or just covered with a net, as the critical reflection angle of water to air is small, people standing beside the tank are not able to look through the water into the service room behind.

Metal in contact with water produces poison to the fish; contact of metal with water in tank construction is therefore to be avoided.

#### j. Piping

In order to avoid water poisoning, asbestos-cement, pitch-fibre, hard rubber, vinyl plastics and other synthetic and chemically inert materials have been used for aquarium piping.

#### k. Lighting

The exhibition hall in which exhibit tanks are viewed through a glazed side should be kept dark enough so that the exhibits could be viewed clearly without reflection from the glass. As the tanks are being lit from the service area behind, they are seen as bright objects in

a dimly lit room. Too great a brightness contrast however is unpleasant and causes eye strain. The best brightness in ordinary viewing would be in the neighborhood of two to one, the object viewed twice as bright as its background. A contrast of five to one are considered to be good and ten to one allowable.

The exhibit tank is best lit from the top front. Lighting from the sides causes nervous disturbance to the fish specimens which are only used to light coming from above. With most of the light coming from the top front of the tank, there is no undesirable silhouetting of the fishes when they swim to the front of the tank as would in the case of light coming from the central top.

As direct sunlight is not necessary for the aquatic species and natural skylight is difficult to control and insulate against cold and heat, artificial lighting is essential. Any special species requiring sunlight can be given artificial ultra-violet rays. Warm fluorescent light is preferred to others in that they produce little heat, consumes little current and gives better light

distribution. The use of artificial light discourages the growth of blue algae.

Salt water tanks need a light source of higher intensity. There are more suspended particles in sea water. Besides biological reasons, the water therefore should also be clean for reasons of lighting.

#### l. Laboratory

In an aquarium a laboratory is essential. It is the place where the composition of the water and its temperature are checked and controlled. It is also a place for research and control of specimen diseases and nutrition.

Basic facilities include work benches, sinks, glass aquaria, tanks, culture tables and scientific equipments such as microscopes, water still, colorimeter, pH meter, incubator and temperature equipment.

#### m. Hatchery

Some aquariums maintain a small hatchery which is usually some tanks in or connected to the service area for exhibit and reserve tanks.

#### n. Collection of Specimens

Besides a small number from the hatchery, some aquariums maintain their own collecting staff and have private trucks, railway cars or boats. Some aquariums obtain specimens from professional collectors or other aquariums by exchange.

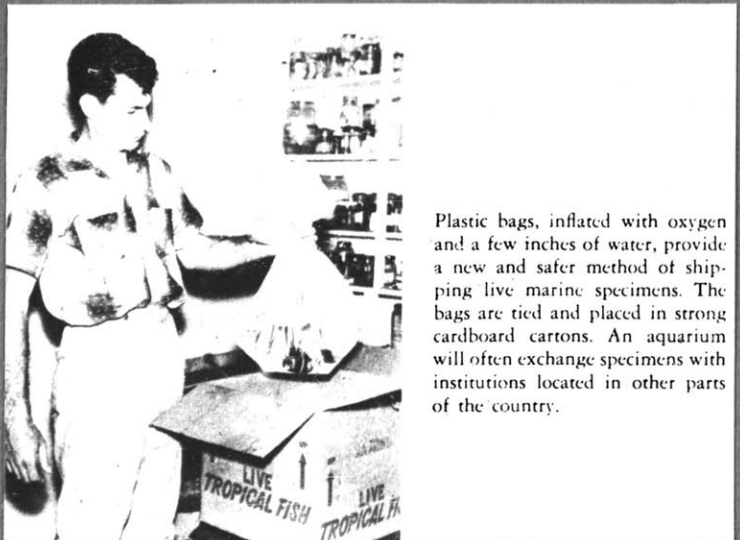

Plastic bags, inflated with oxygen and a few inches of water, provide a new and safer method of shipping live marine specimens. The bags are tied and placed in strong cardboard cartons. An aquarium will often exchange specimens with institutions located in other parts of the country.

## CHAPTER V THE OLD NEW YORK AQUARIUM

### a. General

The old New York Aquarium was situated at the Battery Park which was easily reached by elevated, surface and subway lines. The Aquarium was established by the City in December, 1896, and in 1902, its management was transferred to the New York Zoological Society. The Aquarium was closed in 1941 for tunnel construction.

### b. Tanks

The Aquarium had seven large floor tanks or pools, and 88 exhibit tanks with 22 large reserve tanks containing specimens not on exhibition. In a section devoted to small tropical fresh water fishes, there were 75 small tanks of 4 to 2- gallons. The largest pool was 37 feet in diameter and 7 feet deep.

Before the ever increasing pollution of the harbor by sewage was serious, it was possible to exhibit in the floor pools with seals, sea-lions, manatees and porpoises

with supply of sea water from the harbor. Later the pools were used for fresh water fishes.

**c. The Building**

The building was circular in form, with a diameter of 205 feet. It was originally erected as a fort by the Government.

**d. Mechanical Equipment and Water Systems**

The Aquarium had heating and cooling equipments for controlling the water temperature. The aeration of water was done by a supply of compressed air. The City's water supplied the Aquarium with flowing fresh water and a closed salt water system was employed with an underground reservoir of 100,000 gallons. The same salt water was used since 1907 except for small additions. The pipes from salt water tanks to the reservoir were chiefly lead lined iron pipes later replaced by rubber piping.

**e. The Laboratory**

The laboratory was at times used by specialists in the universities and high schools of the City for marine

biological investigations.

f. The Library

The library had about 1000 volumes of works relating to fishes, fish-culture, fishery industries and aquatic life in general. There was also a collection of pamphlets on these subjects.

g. The Hatchery

The hatchery, maintained chiefly as a fish-cultural exhibit, produces at times several millions of young food and game fishes, which are afterwards deposited in New York State waters.

h. The Collecting Boat

The boat used was a power and sail vessel 35 feet long and had a water compartment for carrying fishes alive and berths for four men.





Interior OLD NEW YORK AQUARIUM



Collection Boat OLD NEW YORK AQUARIUM

## CHAPTER VI THE PROJECTED NEW YORK AQUARIUM

### a. General

After the closing of the old New York Aquarium, plans were underway for the construction of a new aquarium at Seaside Park in Coney Island. The project contains besides exhibition spaces and work areas, a restaurant, an auditorium for school and lecture use, and a library. The main building consists of five major halls connected by overhead passage and a gallery which is also an exhibition area. The halls will contain species in salt and fresh waters from tropical, temperate and arctic regions. To pass from one hall to the other, visitors will ascend and descend a staircase. There will be ramps and staircases for passage to outdoor pools, restaurant and auditorium. The Aquarium will call for the handling of 1,500,000 gallons of water.

### b. Cost Estimates

The estimate in 1957 for the site which contains 12 acres of land was \$1,000,000, and the building, \$8,000,000. It was hoped that once the Aquarium is built, it will be self-supporting by making admission charge. Free admission how-

ever be offered to school groups properly accredited and accompanied by their teachers.

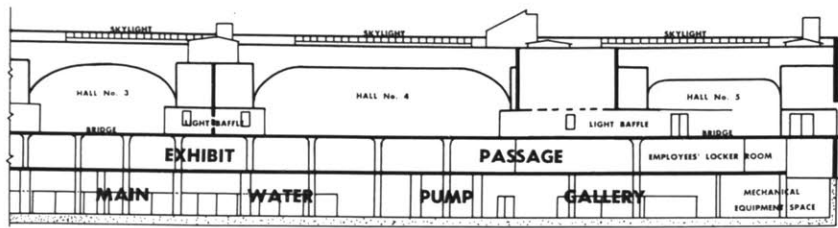

**LONGITUDINAL SECTION**

**PLANS**

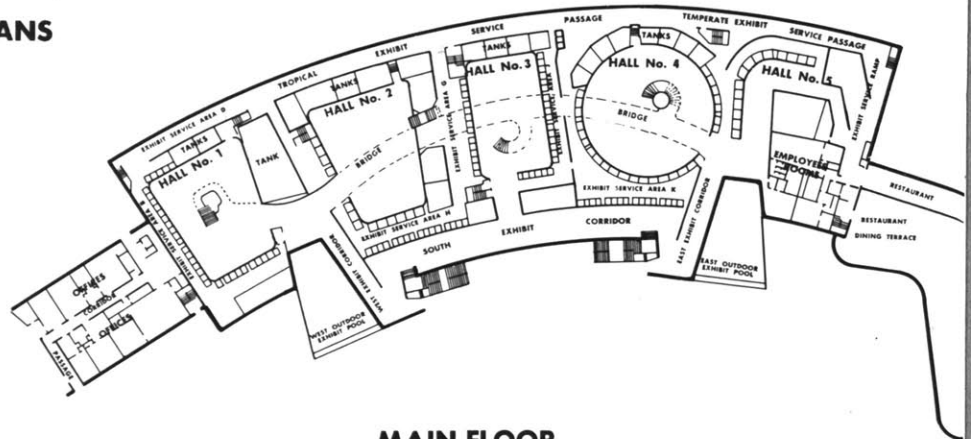

**MAIN FLOOR**

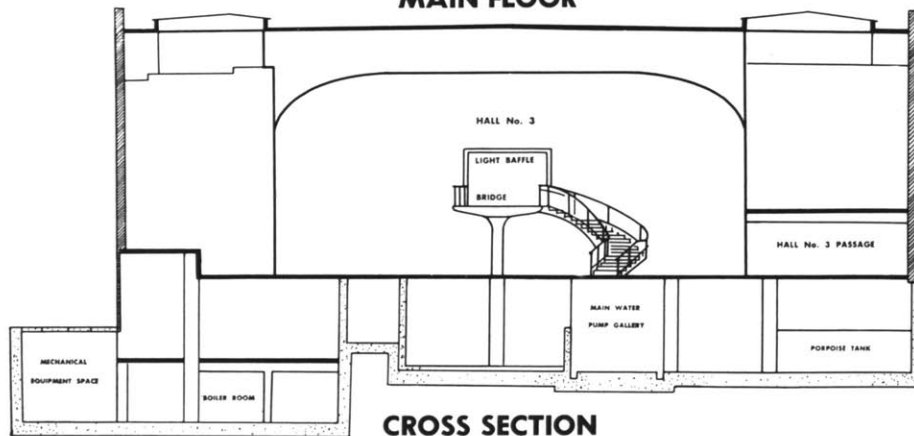

**CROSS SECTION**

**GROUND FLOOR**

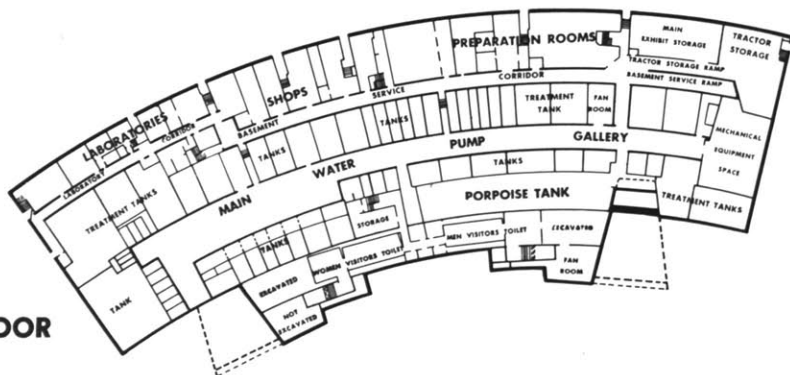

## CHAPTER VII THE NEW YORK AQUARIUM

### a. General and Cost of Building

As money was not available for the whole project, part of the building of the projected New York Aquarium was built as the first stage of the building program. It was decided however, after the completion of the first stage that the rest of the project be abandoned, as the tall big halls were considered too expensive and money would not be available. The cost of the first stage was 1,500,000 dollars.

A restaurant was built at the roof of the building and the offices are housed at the basement at the place where the reservoirs would be according to the original project.

### b. Admission and Opening Hours

The Aquarium is open daily in summer from 10 a.m. to 10 p.m. In winter it is closed on Mondays and Tuesdays except holidays, and open from 10 a.m. till 5 p.m. The admission for adults is 90 cents and children from 5 to 16 years, 45 cents.

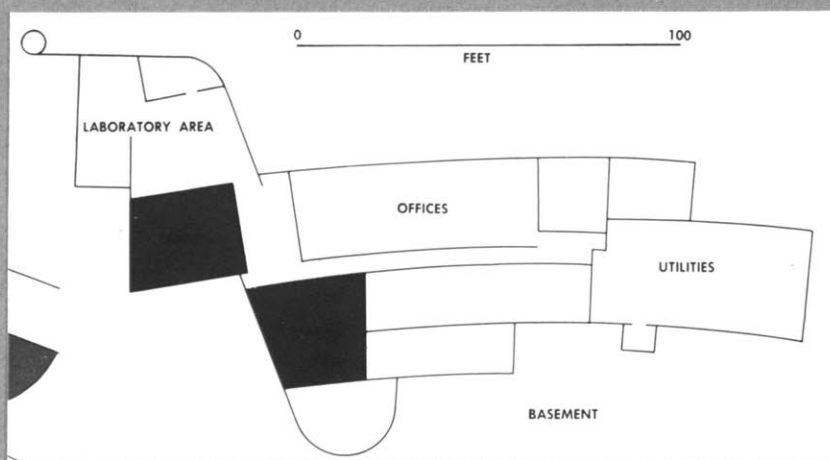
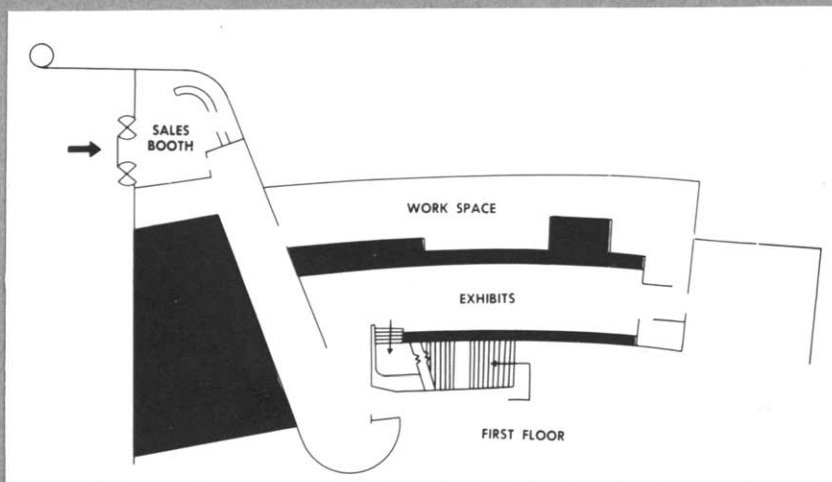
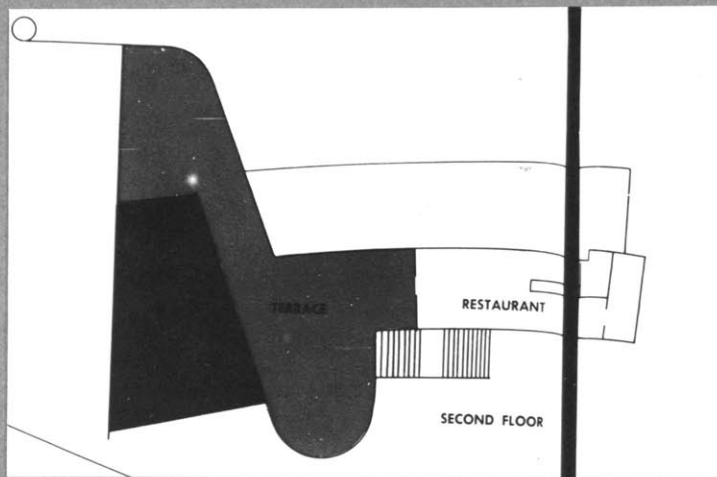

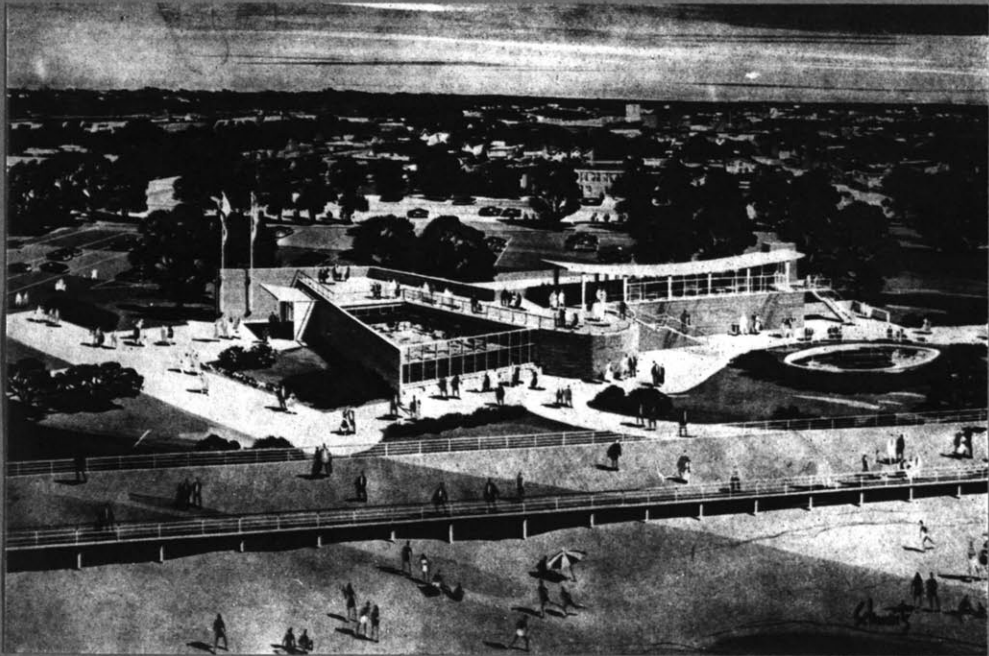
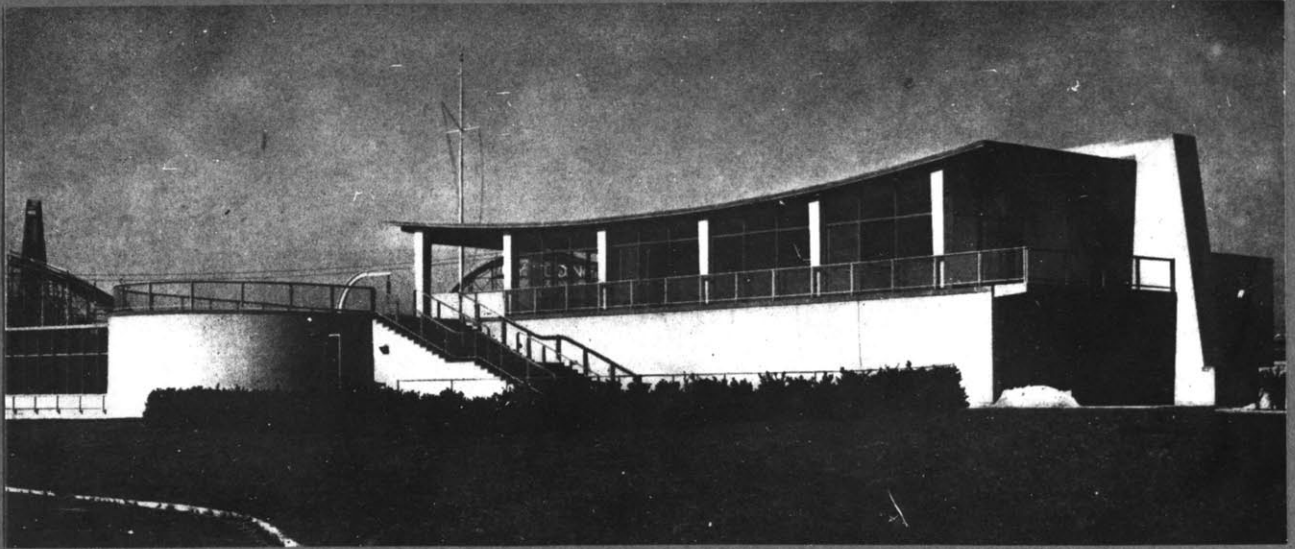

NEW YORK AQUARIUM



Slanting Glass  
of Exhibit Tank  
for Reduction  
of Reflection



Small Exhibit Tanks

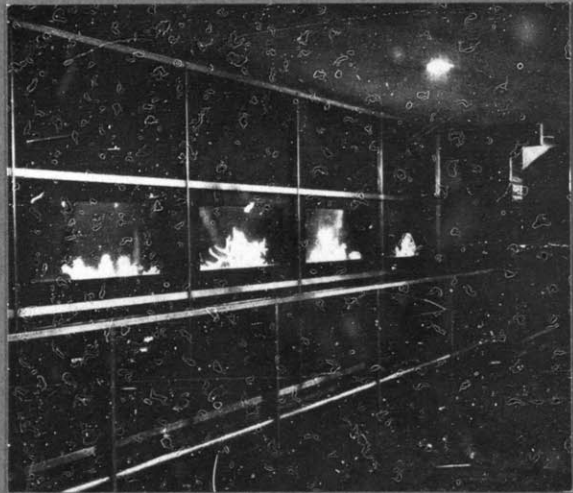

Laboratory

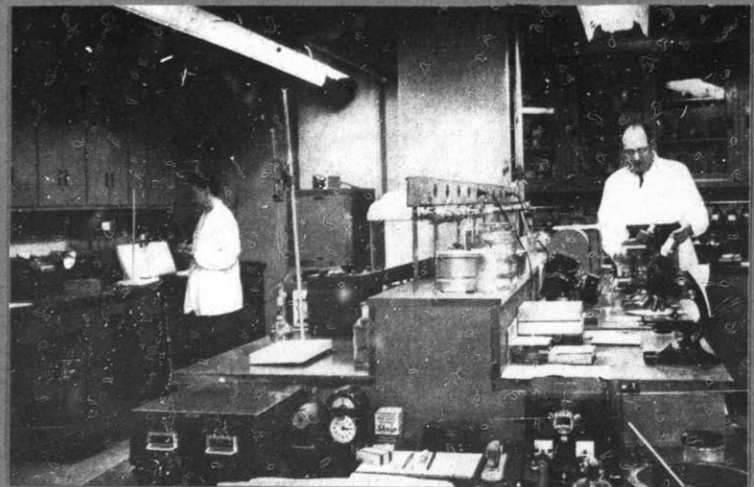

NEW YORK AQUARIUM

## CHAPTER VIII THE LILY ACKERLAND FLEISCHMANN MEMORIAL

### AQUARIUM

This is a small aquarium of domestic scale in Cincinnati, Ohio. It exhibits fresh water native and tropical fishes in two separate rooms. It won the Gold Medal Award of the Architects Society 1950 competition. It has a combined open and closed water system with water supply from the city main. Plastic piping is used.

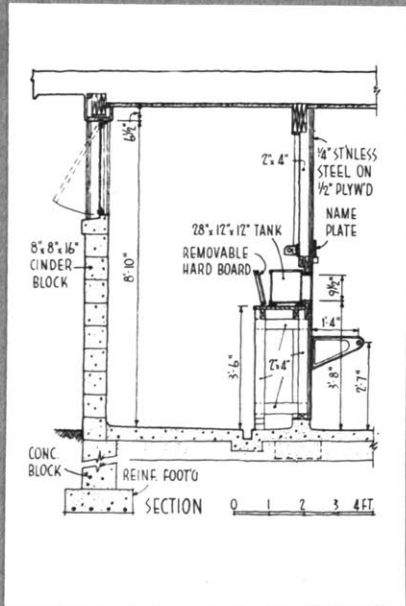
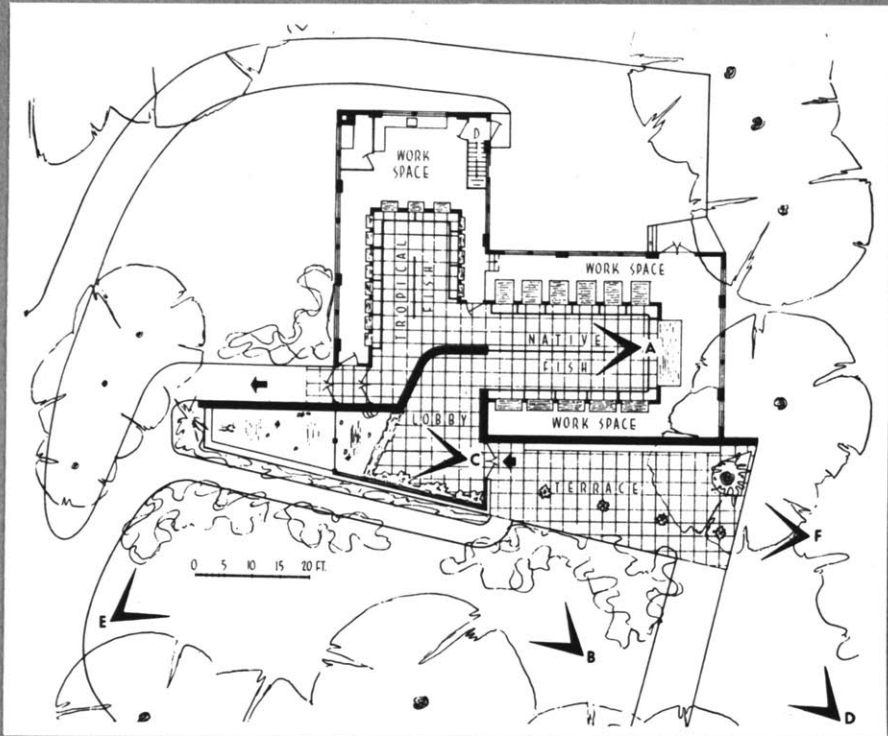

A

LILY ACKERLAND FLEISCHMANN MEMORIAL AQUARIUM

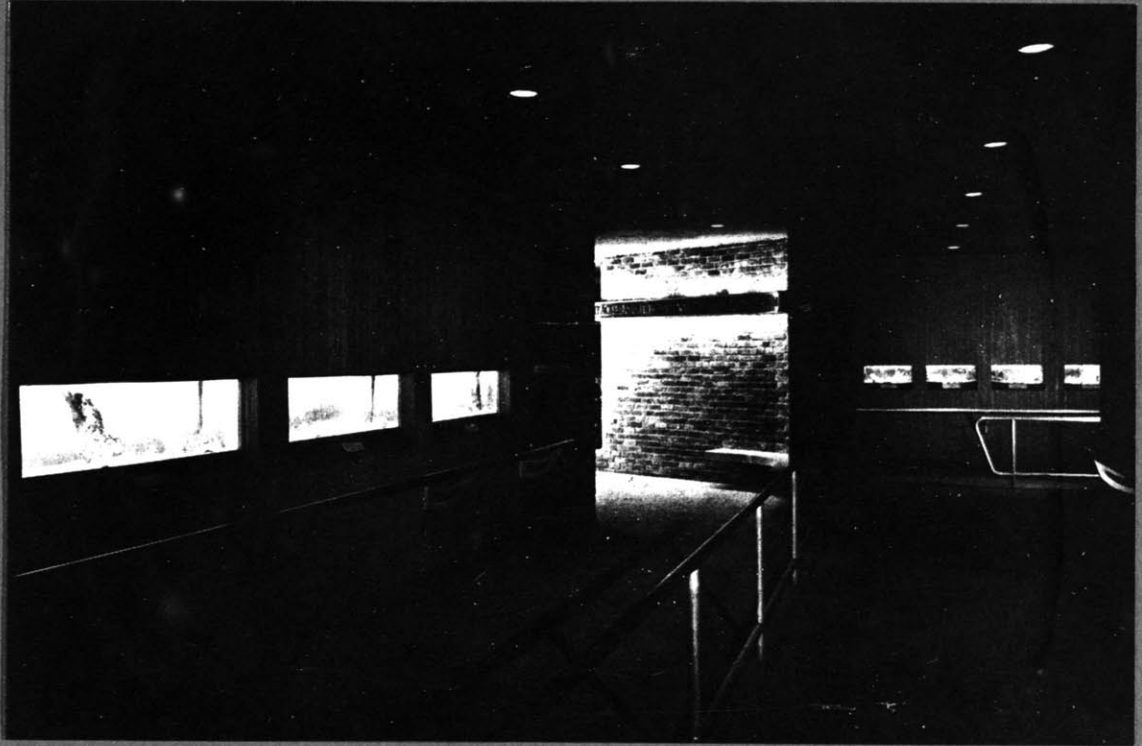

B



C

## CHAPTER IX THE STEINHART AQUARIUM

### a. General

The Steinhart Aquarium at Golden Gate Park, San Francisco, was opened in September, 1923. It is a free aquarium under the management of the California Academy of Sciences, and the City of San Francisco supplies the funds necessary for maintenance. The Academy has in the Park also a Science Museum and a Planetarium. In addition to its service to the visiting public, the Aquarium function as a centre of research in various lines of aquatic biology.

### b. The Building and Its Operation and Tanks

The Aquarium is a reinforced concrete building. On the terrace approaching the Aquarium are three outdoor pools which usually have aquatic mammals such as seals, sea-lions, and otters. The piping is so arranged that the pools can be filled with either fresh or salt water. The central hall of the Aquarium has a large fresh water swamp in the middle with planting, fishes, amphibians and reptiles. The water in it is kept at approximately 78°F.

The building has 57 large exhibit tanks of reinforced concrete with  $1\frac{1}{2}$ " thick glass fronts. The sizes of tanks vary from approximately 500 to 1,400 gallons. They are divided into warm and temperate salt, and warm, temperate and cold water tanks. There are skylights over the tanks. The glass of the skylights is painted with a pale blue paint to produce an even lighting over the tanks and to reduce the growth of algae whose prolific growth constitutes a serious problem in keeping the Aquarium's tanks clean and its tank water clear.

A special room in the basement contains the mechanical equipment necessary to circulate the water, operate the air compressor, refrigeration unit and boiler.

Provision is made in case of emergencies. Air lines are run to each tank should the water supply be cut off.

Fish can live in the same water for a considerable time if air is bubbled through it. An auxiliary gasoline engine is installed to pump air in case the electric current should temporarily fail. There is someone on duty every hour of the day and night.

In the basement are located the offices, a library and a research laboratory.

#### **B. The Water Systems**

Closed water circulation systems are used. The reservoirs have a total capacity of 100,000 gallons. The suspended material in the water is allowed to settle in the reservoirs after the water is passed through a 6'x 6'x 5' filter tank having four feet of fine gravel and sand. Aeration of the water is done by means of a tube which, introducing water from the gravity to the exhibit and reserve tanks, is perforated above the water line in such a way that air is drawn in, although a current of compressed air is also available if wanted.

#### **d. Opening Time**

The Aquarium is open every day of the year from 10 a.m. to 5 p.m.



STEINHART AQUARIUM



## CHAPTER X THE VANCOUVER PUBLIC AQUARIUM

### a. General

The Vancouver Aquarium in British Columbia, Canada, was opened in June, 1956. It exhibits specimens from all over the world and specialize in salt and fresh water organisms of its surrounding area. There are 35 exhibit tanks of 10 to 60 gallons and 33 from 400 to 12,000 gallons. The water in the tanks are kept at constant temperatures varying from 75°F to icy cold. The Aquarium is open every day.

### b. The Water Systems

The large warm salt water tanks receive water from a closed system of 5,000 gallons in which the water is maintained at 75°F and continuously passed through a sand and gravel filter. The small warm salt water tanks are heated by individual electric heaters connected to thermostats maintaining temperatures between 70°F and 75°F. The water is clarified by subsand filters using air from a large compressor in the basement. As the water evaporates from these tanks, it is replaced by preheated water piped from a thermostatically controlled 300 gallons reservoir. Most of the

cold fresh water tanks receive a constant flow of water from the city main in an open system. The water is dechlorinated by a water purifier and filtered by a diatomaceous earth filter. As the city water comes from melting snow at the source of the Capilano River, the water temperature in the tanks is never over 50°F even in summer. Cold salt water is pumped from the sea for marine lives in the North Pacific. The sea water is uniformly cool and is pumped often enough to keep the water temperature from rising above 60 F in summer. It is a combination of open and closed systems. A refrigerating unit is however installed for the octopus specimens which are extremely intolerant of warmer temperature.

The way in which water is pumped from the sea is as follows: An asbestos-cement pipe of about 300 feet acts as a syphon from the lowest low tide level to a deep well in a pump house; this water is then forced by two pumps about 1150 feet up a slope to the Aquarium building (elevation 130 feet) where the water passes through a sand and gravel filter into 350,000 gallon reservoirs in the basement. From the reservoirs three pumps circulate the sea water

through the individual tanks where it flows back through the filter to the reservoirs. The sea water does not have contact with any metal as all pipes and fittings are of polyethylene plastic, hard rubber, or asbestos-cement.

#### c. Supply of Specimens

Local specimens are mainly collected by the Aquarium staff and others are from dealers and from other aquariums by exchange; but many of the common species are bred in the Aquarium and kept on reserve until needed for display.

#### d. Staff

The staff of the Aquarium consists of the curator, engineer, biologist-collector, biologist-technician, tropical aquarist, cold water aquarist, artist, secretary, cashier, caretaker and several part-time employees.

VANCOUVER PUBLIC AQUARIUM

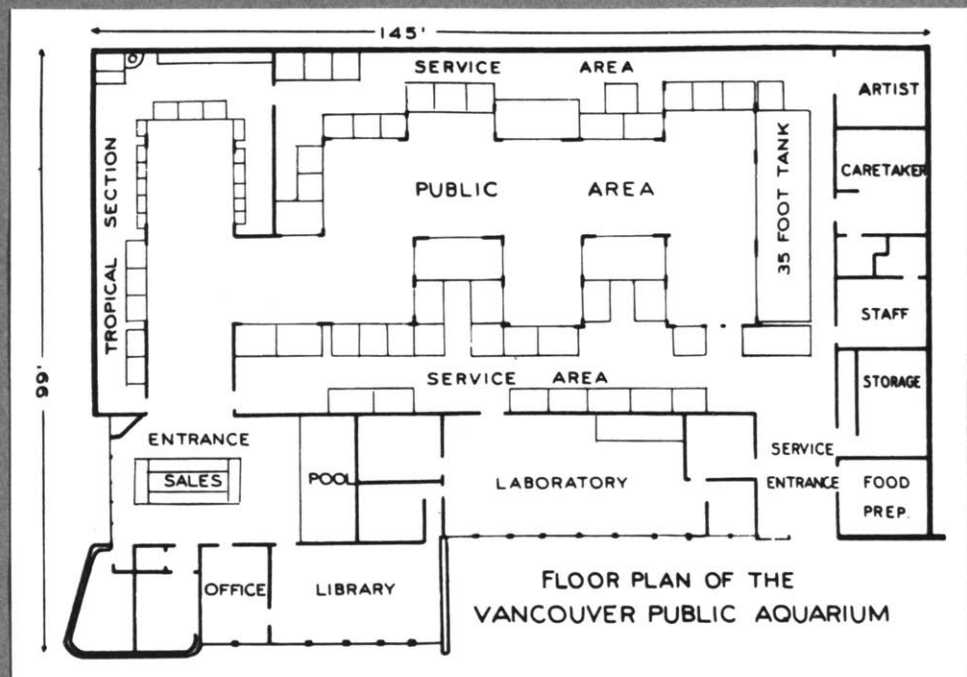
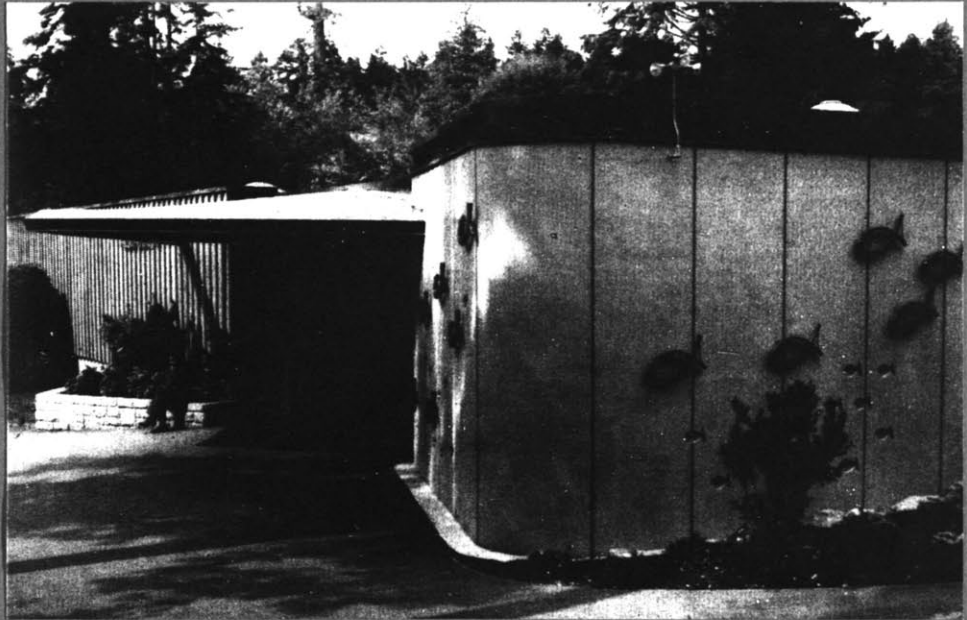

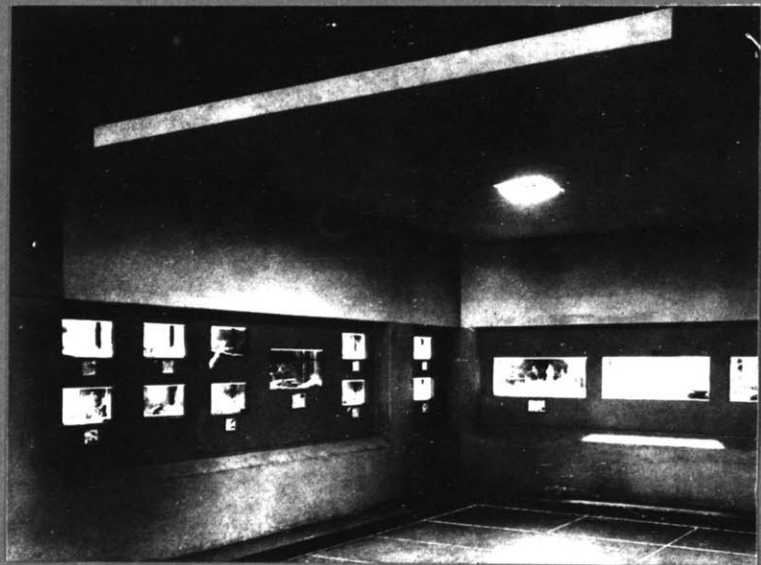

VANCOUVER PUBLIC AQUARIUM

Laboratory



Service Area

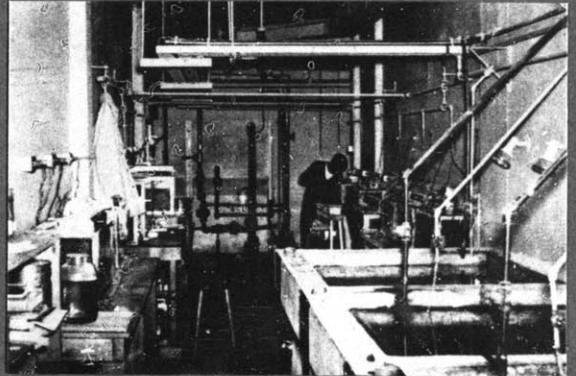

Pumps

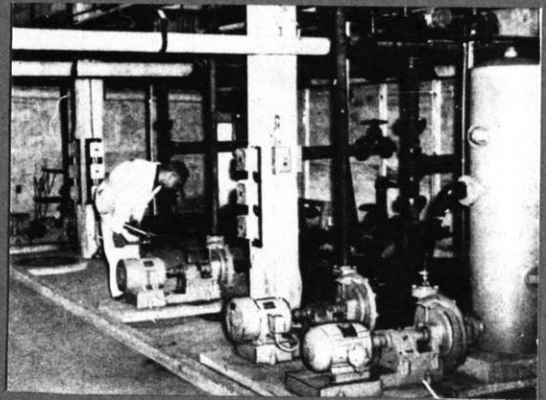

Public Space



## CHAPTER XI THE FRANKFURT EXOTARIUM

### ~~A. The Building and Tanks~~

The Frankfurt Exotarium in Frankfurt-on-Main, Germany, is a building having an aquarium and exhibition halls for reptiles and insects with two outdoor mammal pools. The building was built around the remains of an old aquarium which was destroyed by bombs during the Second World War, in March, 1944. It is in the Frankfurt zoological gardens.

The first hall after the ticket booth contains two large glass walled tanks having penguins from the South Pole in one, and tropical fishes, reptiles, birds and plants in the other. The tanks are partly filled with water and have landscaping above. Each tank has about 6,000 gallons of water.

In the aquarium, the exhibit tanks contain fresh water fishes, coral fishes from warm seas, turtles, North Sea animal in cooled water and seals. There are also two windows at the floor from which one can see the reservoirs containing about 275,000 gallons of water, in the basement.

#### b. The Mechanical Equipments

The Exotarium has 3 refrigerator units, 18 centrifugal pumps, 31 motors, 14 air heaters and ventilators, 60 temperature regulators and engine valves, 17 air-conditioning plants, 15 piping systems with a total length of about 23,000 feet, 2 large filtration units about 72 and 100 feet long, 5 pressure filters with a net weight of up to 20 cwt, 4 large deep reservoirs and 4 overhead gravity tanks for fresh and sea water with a capacity of about 300,000 gallons. In addition, it has a vast number of coal, gravel, peat, pumice and micro-filters.

All fresh water conduits are made of polyvinyl resin. Pumps, mixing valves, counterflow apparatus, and cocks are lined with this synthetic product or nylon. The sea water pipes are made of poly-ethylene, glass or perspex, with the cocks of nylon, and the pumps and pressure filters of acid-resistant ceramics. Neither sea water nor fresh water is allowed to have any contact with metal.

#### c. The Water Systems

The fresh water in the exhibit tanks which contain from



about 770 gallons to 5,950 gallons flows continuously to the preliminary and main filters where it is purified and conditioned before reaching the reservoirs where it has time for self-purification. From there it is forced by automatic centrifugal pumps to the gravity tanks which feed along two conduits to the exhibit tanks. One conduit carries the water in an electrically controlled counterflow apparatus of about 7 feet log, in which it is warmed to 85°F. By means of mixing valve and tubes, also electrically controlled, the water from the two conduits is then brought to the desired temperature, passed through a hydrometer and allowed to flow into the exhibit tanks. If the inflow of heated water should fail, an engine valve immediately cuts off any further inflow, and a rustproof heating coil built-in in the exhibit tank automatically come into operation to maintain the water in the tank at the desired temperature. A similar system is also used for sea water.

#### d. Admission Charges and Opening Hours

Originally it was intended that an entirely new building should be built outside the Zoological Gardens. However

in order to save money, it was built around the damaged aquarium inside the Zoological Gardens. This has resulted in the disadvantage that the building can be visited only if a admission ticket to the Zoological Gardens has been purchased and charge for admission cannot be properly related to the actual costs and exhibition value of the new building. In addition, it is also not possible generally for a visitor to take in and appreciate in a few hours or in one day a large Exotarium and the large Zoological Gardens. For this reason the management of the Gardens decided to vary the hours of opening of the Exotarium by not opening its door until later in the morning, and making it available for visitors in the evening when tickets have stopped being issued for admission to the Zoo. The Exotarium is open daily from 10 a.m. to 10 p.m. and the admission for adult is 1.00 DM and 0.50 DM for children from 2 to 14 years.

Key FRANKFURT EXOTARIUM

1. Pay Box
2. Entrance Hall
3. Climatic Landscapes
4. Polar Landscape with section of sea
5. Tropical Forest Landscape with section of a forest river
6. Entrance to public toilet
7. Filter and water circulation units for climatic landscapes, cooling and freezing units
8. Main Aquarium Hall
9. View of the deep cisterns in the basement
10. Independent tank for Coral Fish
11. North Sea Section
12. Service room for the marine exhibition
13. Mountain trout stream
14. Acclimatization room
15. Exhibition tank for Marine Section
16. Staircase to top floor
17. Ornamental fish
18. Fully automatic heating unit
- 19-20. Reptile Hall
21. Monitors
22. Giant snakes
23. Giant tortoises
- 24-26. Crocodiles
27. Insectarium
28. Exit
29. Revolving door side exit
30. Exotarium farmyard
31. Part of Machinery installation
32. Offices
33. Water reservoirs which take up the whole tower
34. Small zoo pond
35. Inside den of Sea Lion pond
36. Rainwater collecting tank in tower of Exotarium

# PLAN

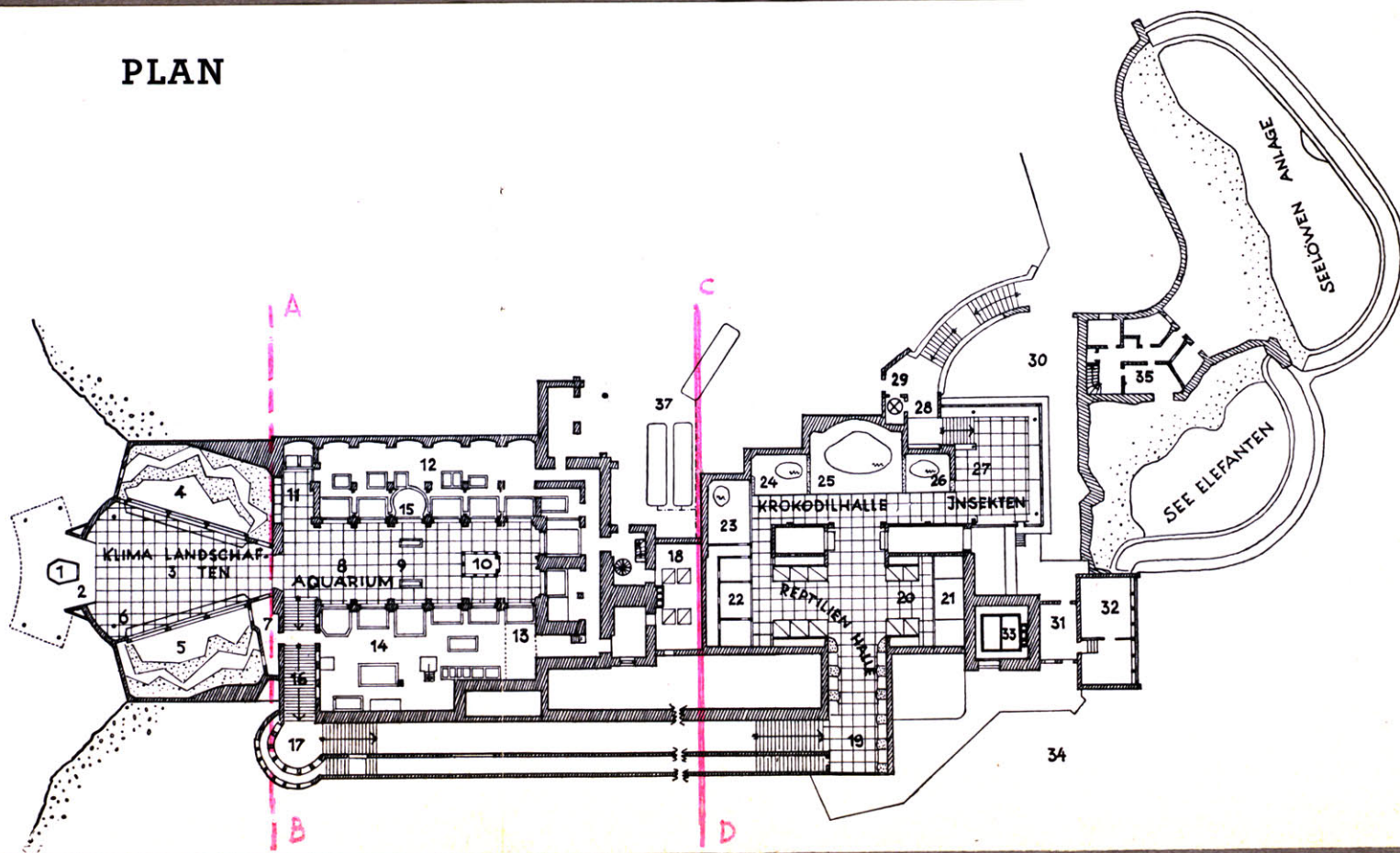

First Floor & Second Floor, Line AB directly under CD FRANKFURT EXOTARIUM

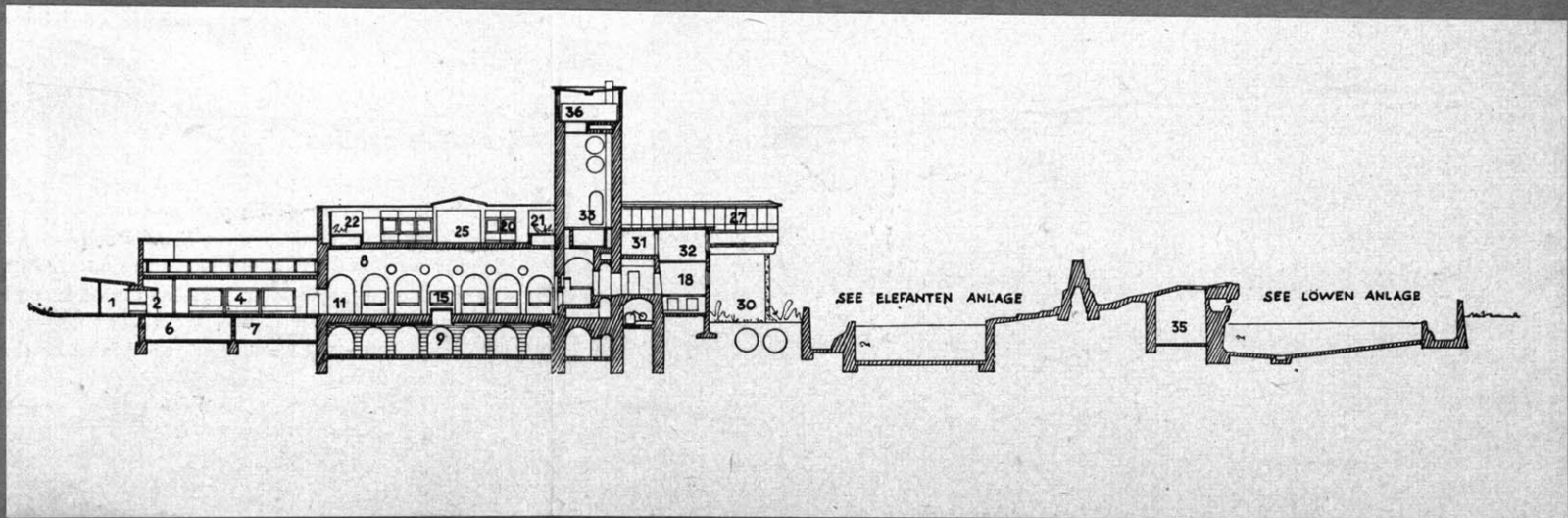

Longitudinal Section FRANKFURT EXOTARIUM

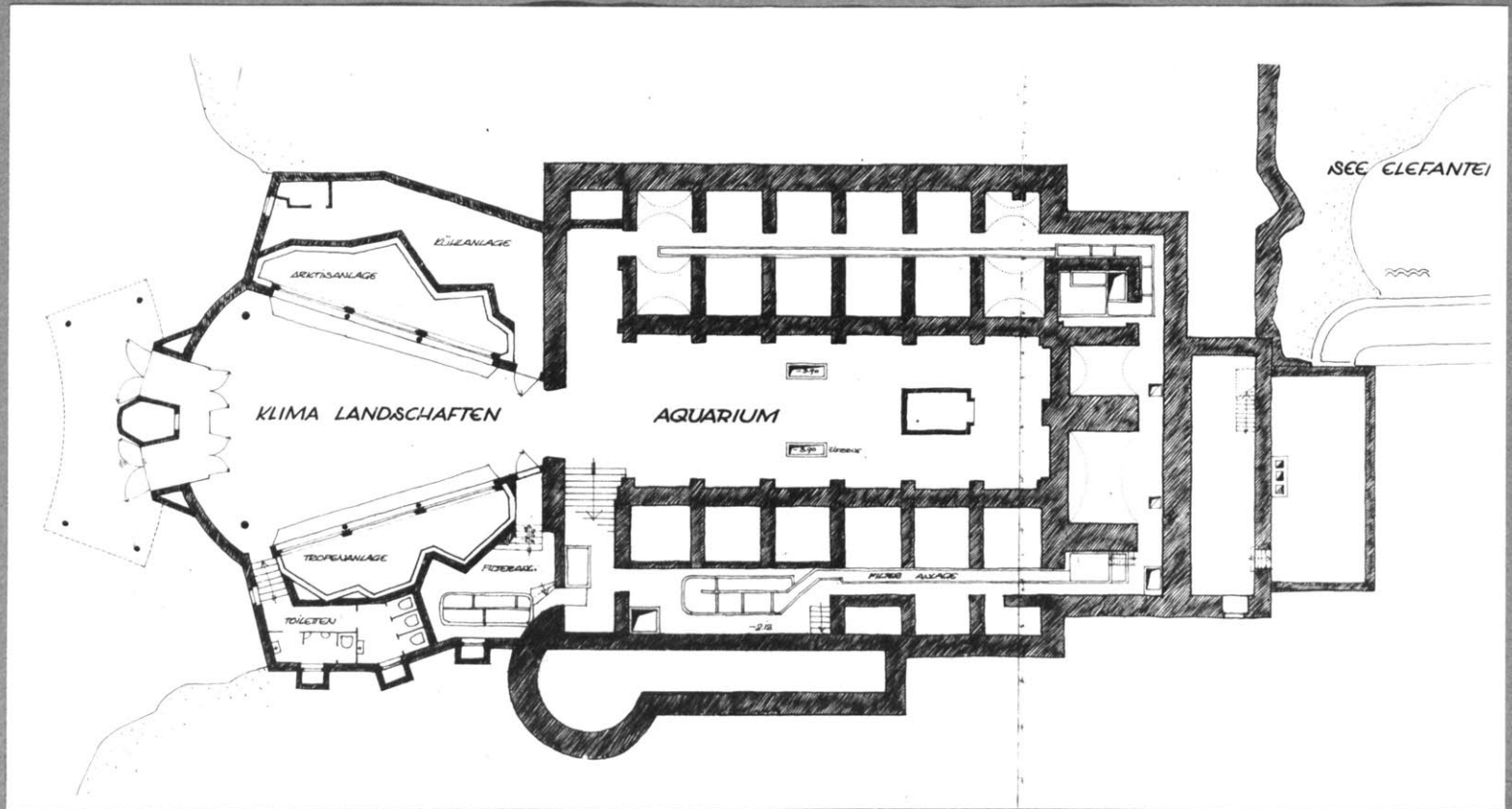

Basement FRANKFURT EXOTARIUM

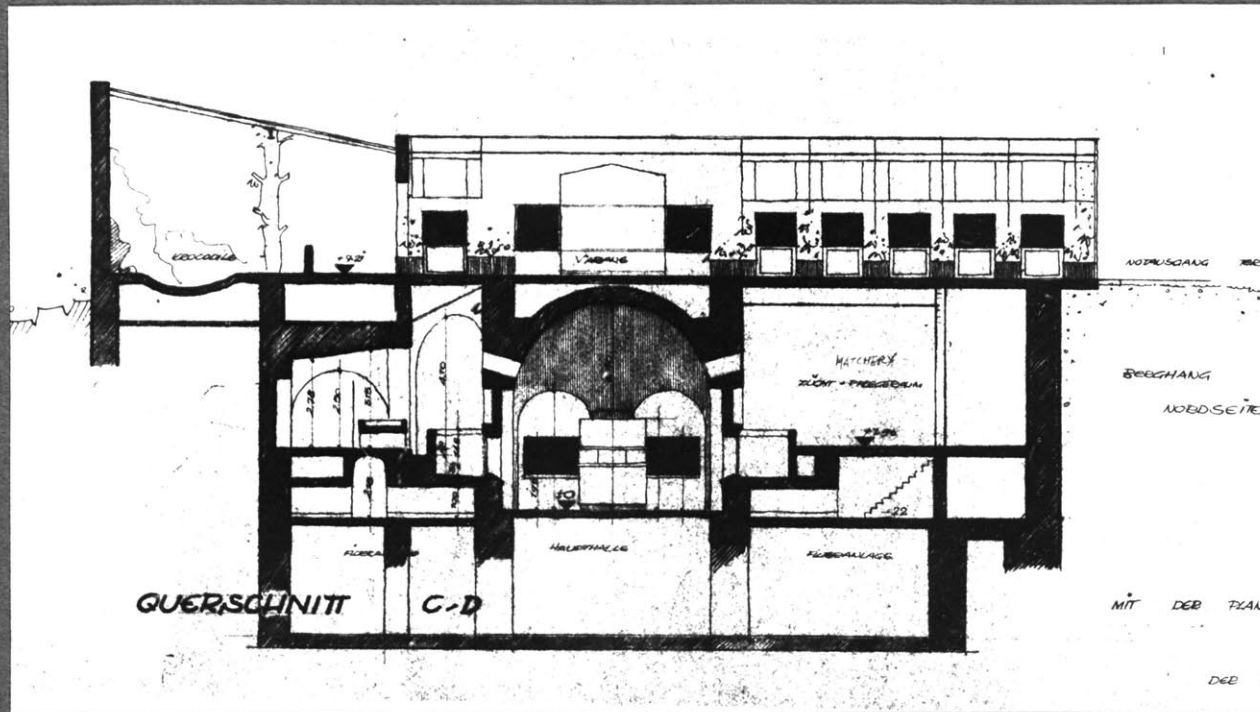

Cross-section FRANKFURT EXOTARIUM



Climatic Landscapes Room



Entrance





Aquarium Hall



Common Seal

## CHAPTER XII THE OPEN-AIR AQUARIUMS

The open-air aquariums in warm regions usually have in a large single tank a large number of different species. The large tanks are claimed to provide for the specimens an environment which closely resembles the natural one in the ocean. By keeping the animals well-fed, the effect of predators upon the total tank population is greatly reduced and is considered as negligible. The identifying of the species by the visitors however, may be difficult. The specimens cannot be successfully labelled and they may also swim away when visitors are looking at them. The small individual tanks are still considered good for close viewing or study especially the small and the delicate specimens. They can also be better taken care of, by being kept in small tanks.

### A. THE MARINELAND, FLORIDA

#### a. General

The Marineland in Florida operated by Marine Studio Inc. is one of the open-air aquariums with large outdoor exhi-

bition tanks. The Marineland was opened in June, 1938. It was closed down in 1942 because of the War and was re-opened in 1946.

b. The Tanks and Water Supply

The aquarium has a circular tank of 75 feet in diameter with a depth of 12 feet. It contains 400,000 gallons of sea water which is pumped from the ocean through underground pipes beneath the beach. Since the water seeps through the sand into the pipes, it is naturally filtered. The water is aerated before reaching the tank and part of the water discharged from the tank is recirculated after being passed through a filtration plant located nearby. Porpoises and some other species are contained in this tank. A ring of glazed windows are built along the side of the tank. Visitors may see divers going into the tank to feed the animals from these windows, while from the top of the tank, they may see porpoises leaping out of the water to take fish from the attendant's hand.

There is another tank of 100 feet long and 40 feet wide, with a depth of 18 feet containing 450,000 gallons of

water similarly supplied from the sea. This tank is heated during the winter to keep the water temperate from falling below 68°F. Specimens that are considered more dangerous, the sharks, rays, moray eels and barracuda, are contained in this tank. There are also windows around the perimeter of the tank and a diver also goes into the tank to feed the animals.

Small indoor exhibit tanks are also built by Marineland along a corridor.

A third tank, called the porpoise stadium, 40 feet x 100 feet x 5½ feet deep at the edges was constructed in 1954 for viewing performances by trained porpoises.

The tanks are cleaned about three times a year. The gravel bottom is removed from the tanks by means of water suction, and fresh gravel is placed in the tanks.

#### c. The Laboratory, Employees and Collecting Boat

The research laboratory accumulates scientific knowledge about specimens kept in the tanks. There are about 110 persons employed by Marineland. Its collecting boat is 46 feet in length and has a 10'x 11' tank in the boat.

MARINELAND, FLORIDA

Aerial View



Collecting Boat

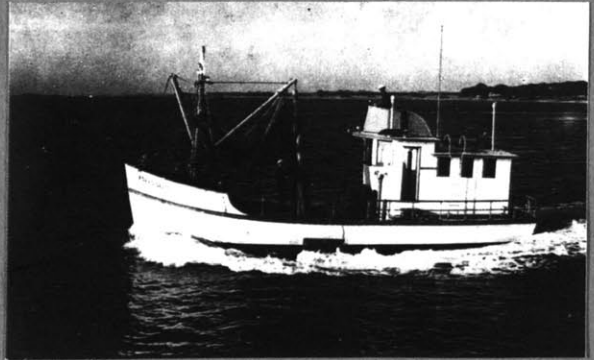

Pelicans & Porpoise



d. Opening Time, Admission, and New Specimens

The aquarium is open from 8 a.m. to 6 p.m. Admission for adults is \$ 2.20 and for children 6 to 11 years, \$1.10.

Recently the aquarium has procured young pilot whales.

They are now under training for future performance.

B. THE MARINELAND OF THE PACIFIC

a. Tanks

This aquarium in California is a three-ring sea circus consisting of three reinforced concrete tanks with stadium seating around two of the tanks. Three performing pilot whales are kept in the 80 foot diameter circular tank which is 22 feet deep, and holds 540,000 gallons. Other species native to the region are also kept in it. An oval tank of 50 feet x 100 feet has species of a migratory nature. These tanks have viewing windows around their perimeters and a diver goes into them to perform feeding as in the Florida's Marineland. The third tank, called a sea arena, is for staging performances by porpoises and sealions. The tank is 120 feet x 60 feet having a capacity of 500,000 gallons. The first two were constructed in

1954, and the third one in 1958. Besides the giant tanks, there are small indoor exhibit tanks, an outdoor harbor seal pool and a flamingo garden.

b. The Aquarium Structure and Water Supply

The tanks have around it reinforced galleries at different levels. Visitors reach the various levels by exterior ramps. The scheme involves the visitors several trips in and out of doors.

The sea water is drawn from the ocean by asbestos-cement pipe buried in the beach below the tide level. The pipe is perforated and absorbs the water into a sump. The water in the sump is then lifted 125 feet by two 100 hp pumps. After sand-filtering and chemical treatment to retard growth of algae and other plant life, the water is introduced into the giant tanks at the bottom through four jets that cause the water to rotate in the tank at velocities adequate to provide self cleaning. Asbestos-cement piping is used for all fresh and salt pipes buried in the ground and the large salt water lines inside the building are plastic, and special metals were used in the valves, pumps,

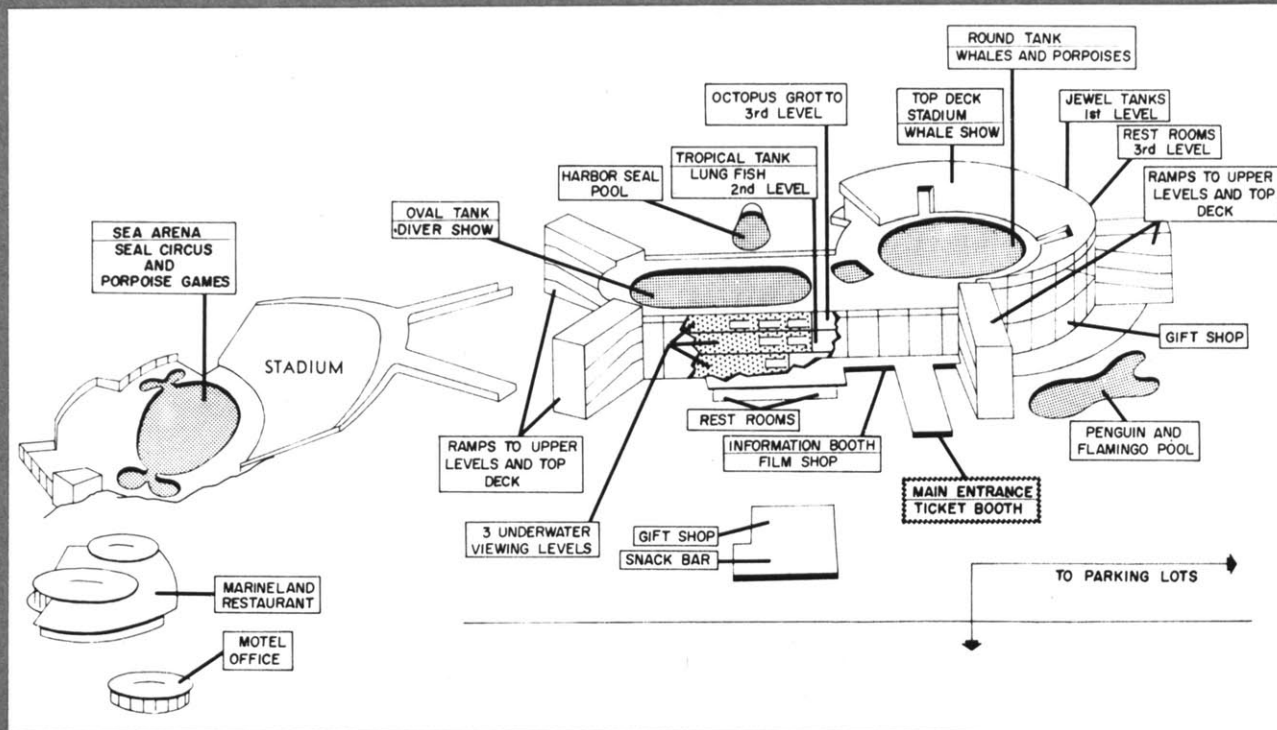

MARINELAND OF THE PACIFIC



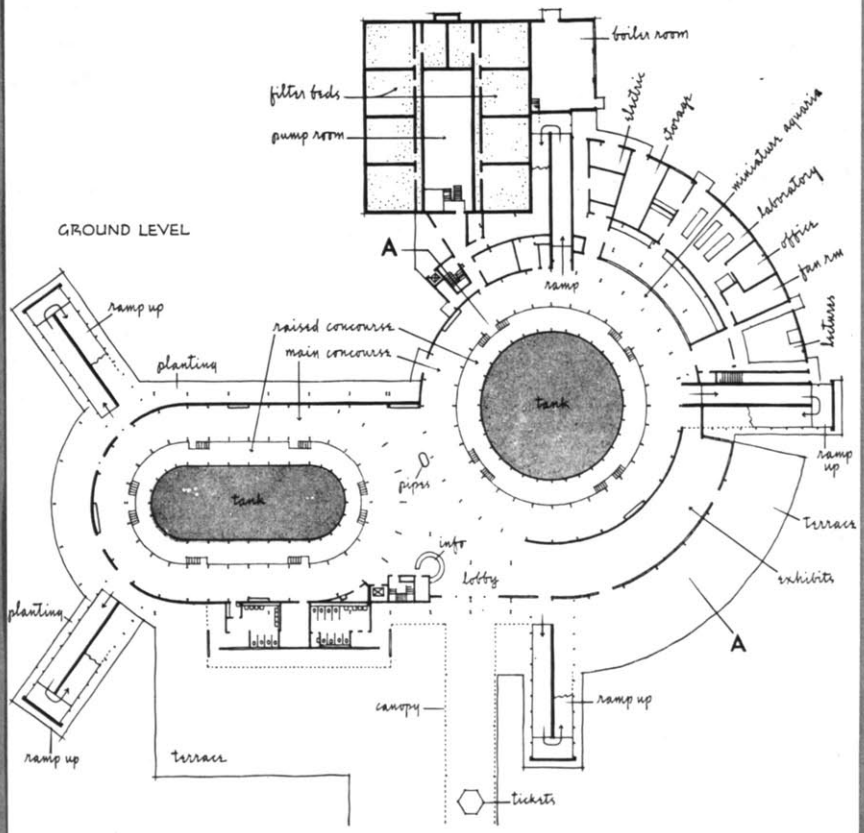
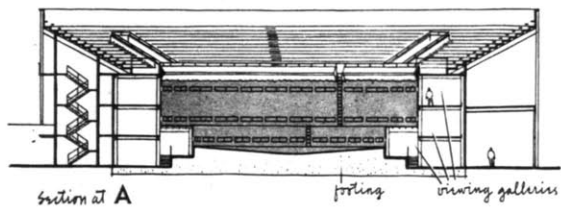
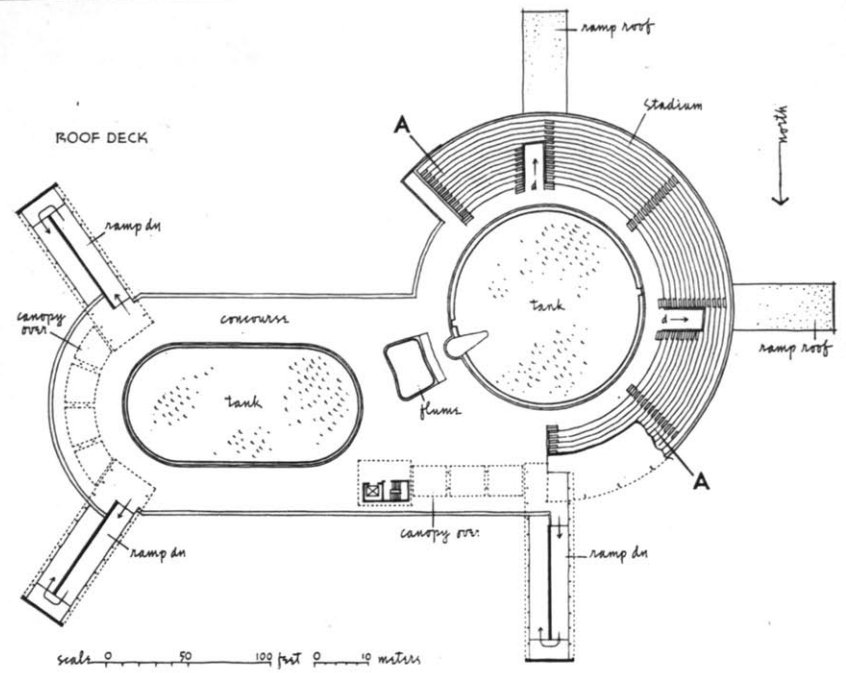

and heat exchangers.

The water temperature in the circular tank is allowed to fluctuate with the weather. In the oval tank the temperature is kept at 72°F by a hot water heat exchanger immersed in a supply tank adjacent to the filters. No heating is provided in the sea arena.

#### c. The Building Site, Opening Time and Admission

The building and grounds including a restaurant occupy a 70 acre site on the tip of a peninsula. The Marineland is open from 10 a.m. until sunset daily. Admission for adults is \$2.00 and children, 50 cents. There are 16 acres of free parking space.

#### C. THE MIAMI SEAQUARIUM

a. General Information was opened in September 1955.

This aquarium was opened in September, 1955. It is made up of six major elements: the 80 foot main tank, the 50 foot reef seaquarium, the 26 corridor aquariums, the 150 foot shark channel, the seashow arena and the lost islands where tropical tidal fish, iguana lizards and water birds

are kept for exhibition. 2,000,000 gallons of sea water is used for the whole Seaquarium.

b. The Tanks and Pools

The 80 foot diameter circular main tank is 17 feet deep and has a capacity of 602,000 gallons. The glass windows around it are in two rows. The windows are 20" x 42" each. The windows are double-glazed. The lower panes are 5/8" thick, and the upper panes are 3/8" thick. In this tank are kept porpoises, sharks, sting rays, turtles and a number of other species. The 50 foot reef seaquarium is circular tank of 17 foot depth containing 235,000 gallons of sea water and having its bottom covered with rocks and pieces of coral taken from the reefs fringing the Florida Keys. Many species of colorful reef fishes and game fishes are kept there. More than 100 big sharks are kept in the 750 feet long circular ring pool. The seashow arena is a large open-air tank for porpoise and seal performances.

c. Opening Time and Admission

The Seaquarium is open year round. Admission for adults is \$2.20, and children 6 to 14 years pay half price.

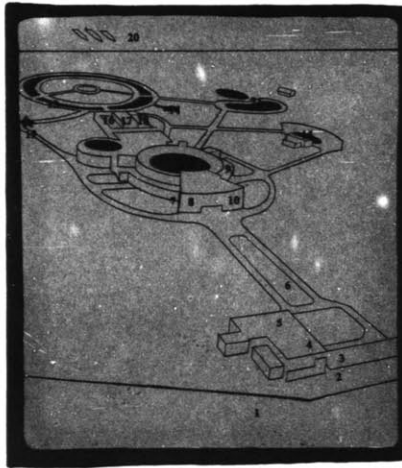

1. parking Lot
2. Front Entrance
3. Ticket Office
4. Rest Rooms
5. Gift Shop
6. Main Promenade
7. Ladies' Room
8. Film Shop
9. Corridor Wall Tanks  
(all around main tank)
10. Men's Room
11. Main Seaquarium Exhibit #1
12. Reef Seaquarium Exhibit #2  
(shark show)
13. Shark Channel Exhibit #3
14. Sea Cow Exhibit #4
15. Sea Show Arena Exhibit #5
16. Rest Rooms
17. Nautical Snack Bar
18. Rest Rooms
19. Lagoon
20. Boat Dock
21. Lost Islands Exhibit #6

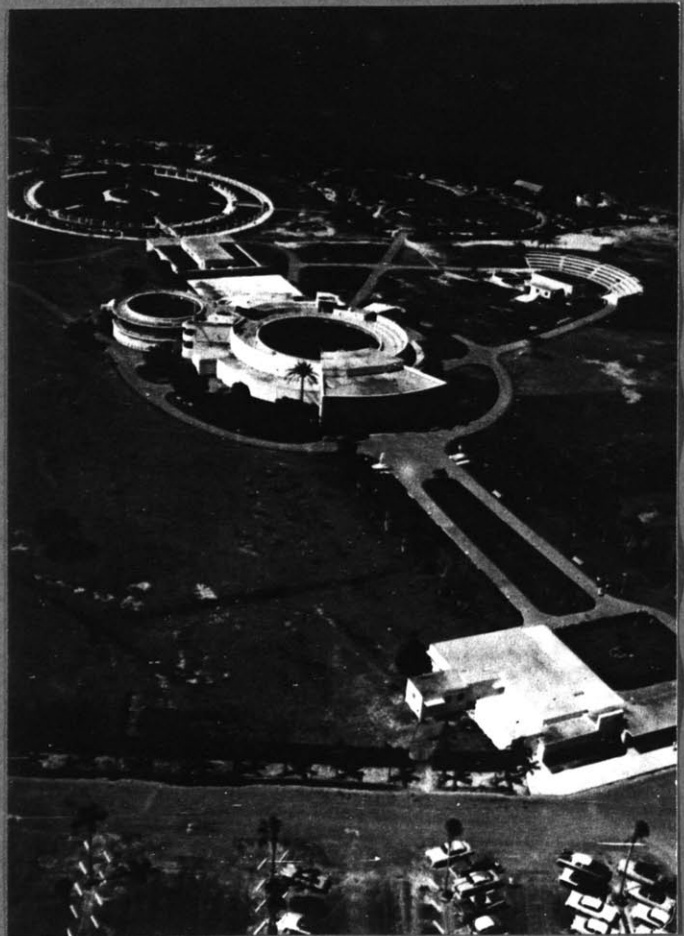

MIAMI SEAQUARIUM

MIAMI SEAQUARIUM

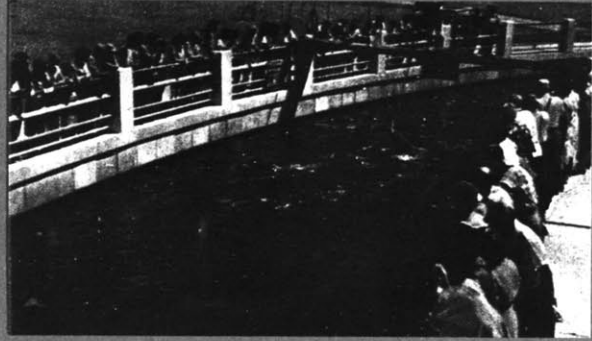

Shark Channel

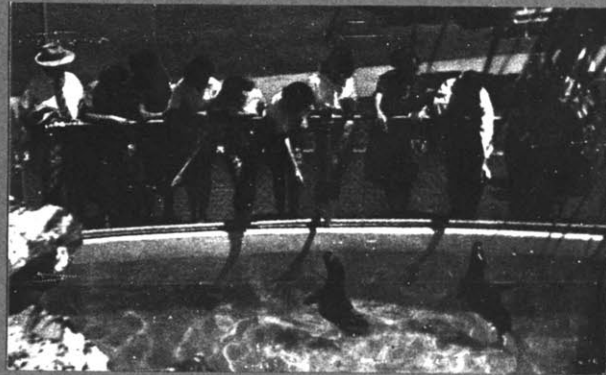

Harbor Seals



Corridor Tanks

### CHAPTER XIII THE NAGASAKI AQUARIUM

The Nagasaki Aquarium in Japan was opened in 1959. It is inside a park by the sea. The park is under construction and land is partly being reclaimed from the sea.

The building has a reinforced frame and native Goto stone walls. The water used vary in temperature from about 40°F to 82°F. Heating and cooling equipments are installed. There are both fresh and salt water exhibits.

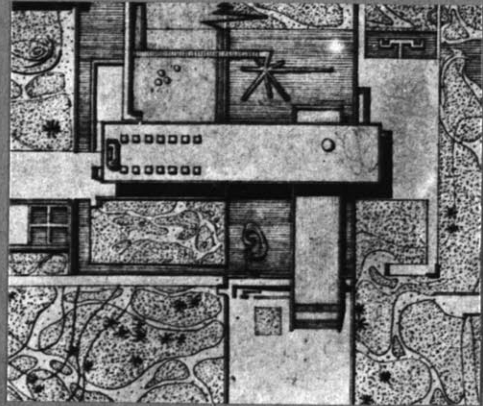

NAGASAKI AQUARIUM

Key NAGASAKI AQUARIUM

- |                            |                                   |
|----------------------------|-----------------------------------|
| 1. Boiler Room             | 25. Lockers                       |
| 2. Pump Room               | 26. Library                       |
| 3. Electrical Controls     | 27. Laboratory                    |
| 4. Fresh Water Filter      | 28. Terrarium                     |
| 5. Salt Water Filter       | 29. Ventilation                   |
| 6. Rest Room               | 30. Fresh Water Fish<br>Work Room |
| 7. Electricity Generator   | 31. Big Pool                      |
| 8. Refrigerating Room      | 32. Hall                          |
| 9. Tropical Fish Work Room | 33. Entrance Hall                 |
| 10. Public Area            | 34. Free Rest Room                |
| 11. Oceanarium             | 35. Public Area                   |
| 12. Public Area            | 36. Marine Fish Service<br>area   |
| 13. Men                    | 37. Dry Exhibits                  |
| 14. Women                  | 38. Open                          |
| 15. Hall                   | 39. Open                          |
| 16. Reception Room         | 40. Open                          |
| 17. Curator                | 41. Tea Room                      |
| 18. General Office         | 42. Kitchen                       |
| 19. Dark Room              | 43. Paint Room                    |
| 20. Guards                 |                                   |
| 21. Boys                   |                                   |
| 22. Dormitory              |                                   |
| 23. Bath                   |                                   |
| 24. Lockers                |                                   |



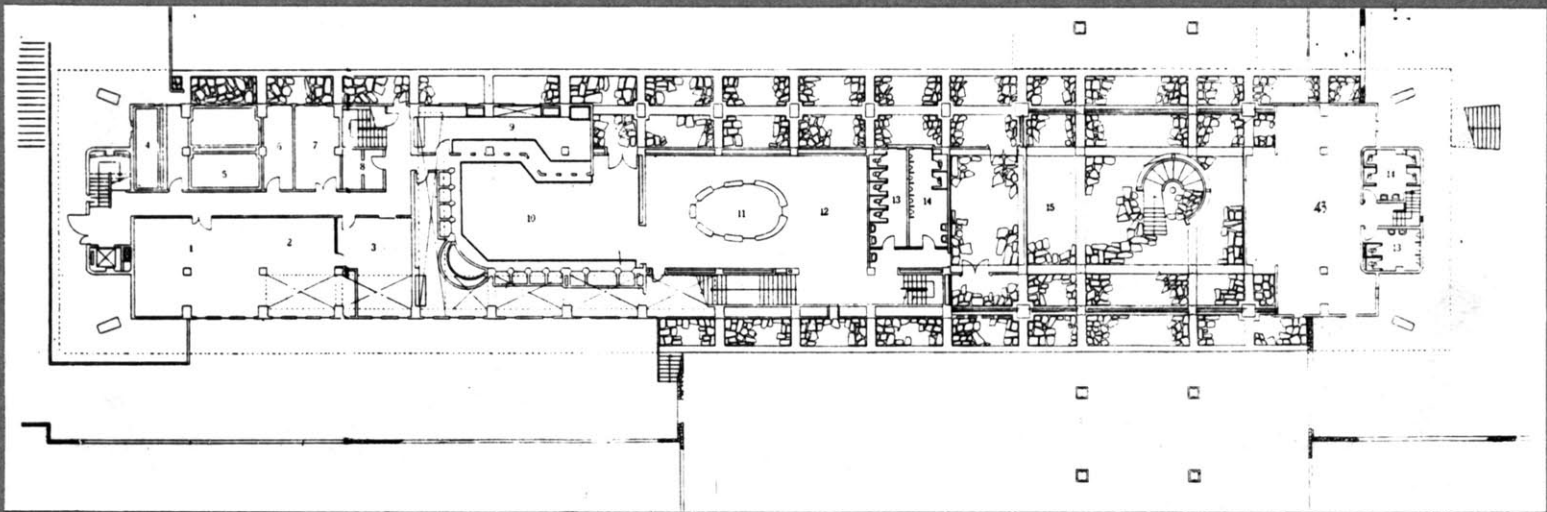

1st Floor NAGASAKI AQUARIUM

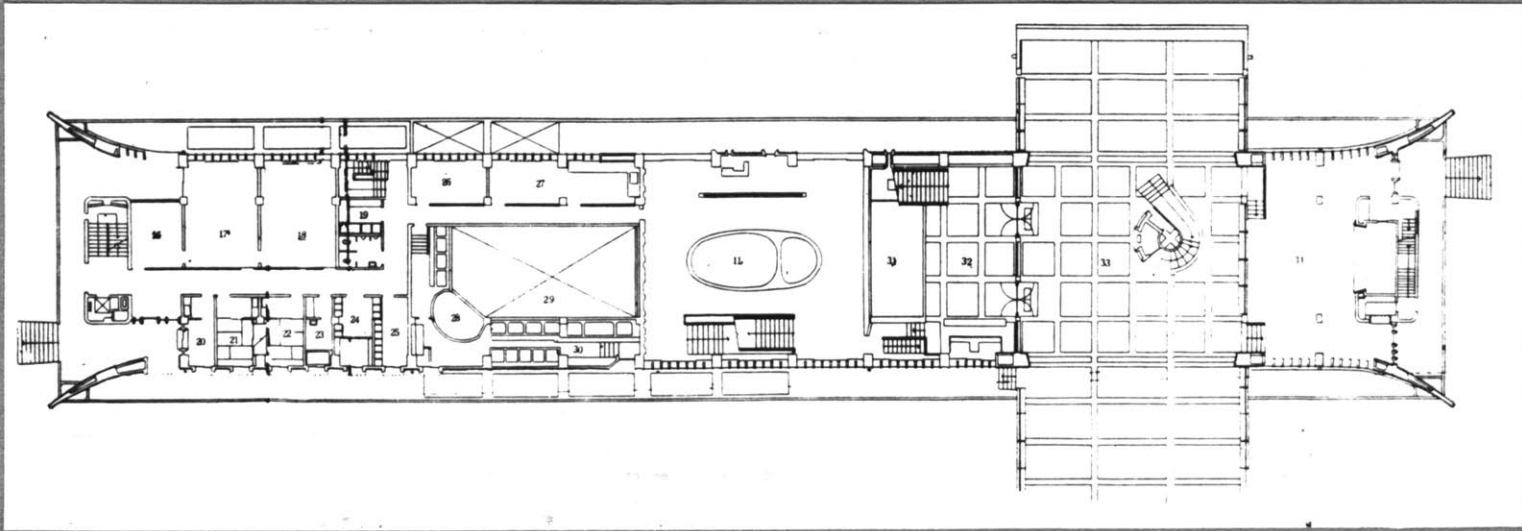

2nd Floor NAGASAKI AQUARIUM

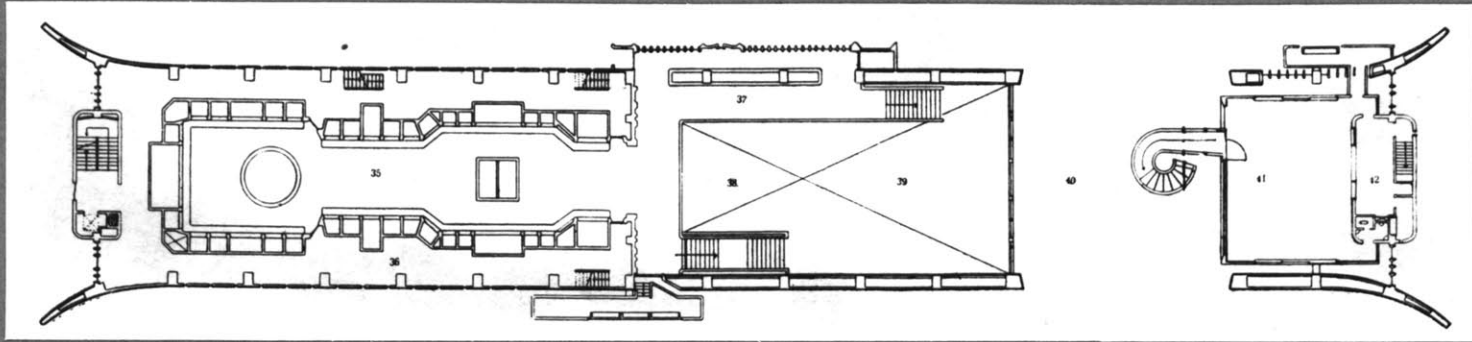

3rd Floor NAGASAKI AQUARIUM

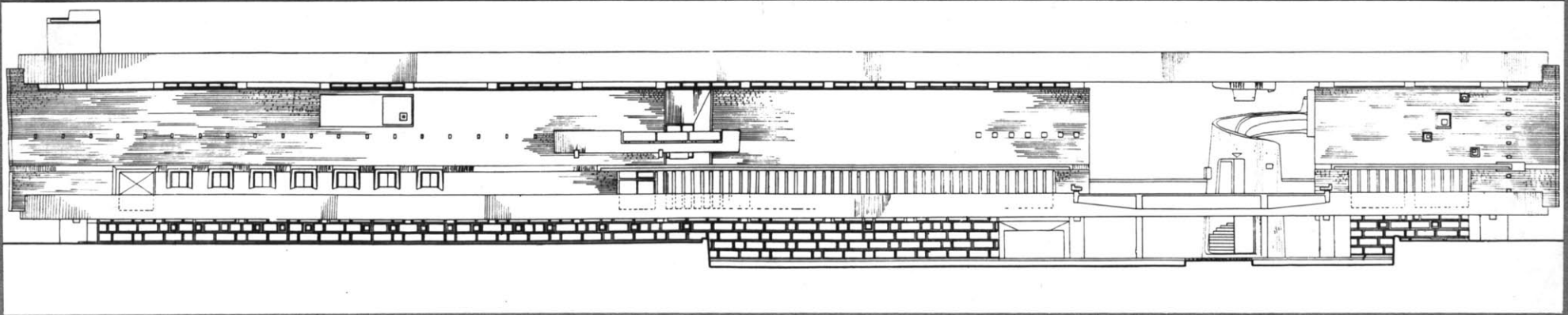
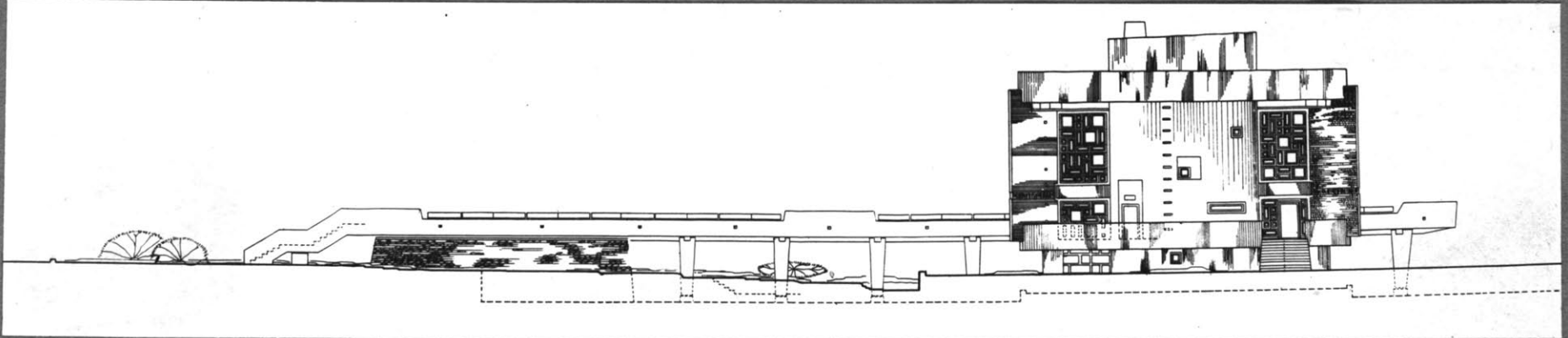

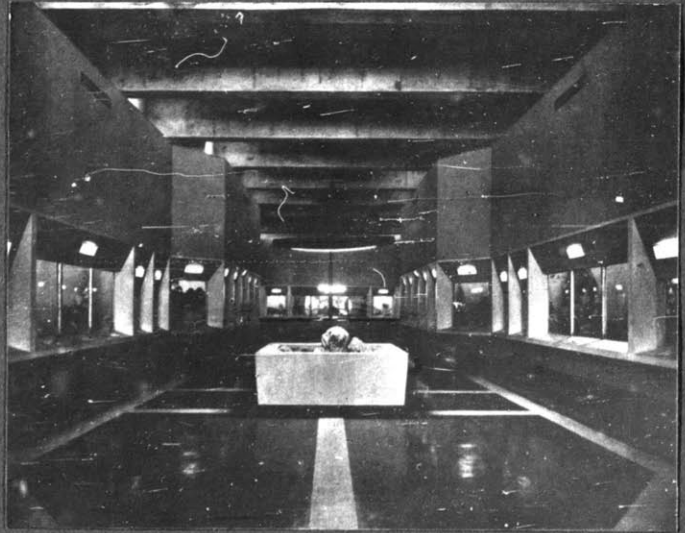

NAGASAKI AQUARIUM

#### CHAPTER XIV THE SITE FOR THE BOSTON AQUARIUM

The site chosen for the Aquarium is located at the southern end of Boston's Carson Beach which faces the Old Harbor in Dorchester Bay. The site includes part of the filled land adjoining the Columbus Park and part of the Park. The filled land is at present for sale and the value of the surrounding land at that area near the filled land is from 50 cents to one dollar per square foot.

The site is chosen because of its location by the sea. There are unpolluted natural sea water and beautiful views. The sea not only supplies the necessary salt water, but also provides access to boats delivering specimens or food supply for the animals. The open park and swimming beach provide added scenic attractions to the place.

The site is easily reached. There are a highway running pass the Park and a MTA subway station nearby.



Overhead View of Site



View of Site towards North-East



Bath-house and Beach North of Site



View of Site towards the East



## CHAPTER XV THE PROGRAM FOR THE BOSTON AQUARIUM

The Aquarium is to be a museum of living aquatic species with supplementary dry exhibits. Boston is a place of severely cold winters and hot summers. The exhibit tanks will be housed indoors for maintenance of water at different temperatures and comfortable viewing by visitors.

The Aquarium is assumed to have a maximum traffic of about 3,000 persons per day and 1,000 persons at one time. By studying the monthly attendances of the Museum of Science, the Museum's maximum traffic per day is estimated to be 1,200 persons. The average number of persons visiting the New York Aquarium after its completion, in 1957 was about 9,000 persons per day.

The Aquarium is to provide parking space for about 200 cars, assuming 400 coming by public transportation and the remaining 600 of the 1,000 coming by private cars with an average of 3 persons per car.

(1) Entrance hall with ticket booth, information desk, check room, stall for selling publications, etc., lavatories, and telephone booths

(2) Tanks

As species in the tanks will be changed, the kind of water in the tanks may also be changed. The following however gives the initial arrangement.

A. Fresh Water

a. Warm water

Exhibit Tanks

1/ 11x8x5 (dimensions of volume of water in feet)	3,300 gallons
2/ 6x5x5	2,250
9/ 4x4x3	2,430
10/ 3x2x2 $\frac{1}{2}$	1,125
20 glass tanks average 15 gallons each	300
	<u>9,405</u>
1 shallow floor tank for reptiles and amphibians	9,000
	<u>18,405</u>

Reserve Tanks

1/ 12x8x6	4,320
1/ 6x5x5	1,125
4/ 4x4x3	1,440
4/ 3x2x2 $\frac{1}{2}$	450
20 small glass reserve tanks	300
	<u>7,635</u>

Reservoirs

22,000

b. Temperate water

Exhibit Tanks

1/ 13x10x6	5,850
2/ 8x6x5	3,600
2/ 6x5x5	2,250
6/ 4x4x3	2,160
3/ 3x2x2½	337.5
10 glass tanks average 15 gallons each	150
	<u>14,347.5</u>

Reserve Tanks

1/ 12x8x6	4,320
2/ 8x6x5	3,600
1/ 6x5x5	1,125
4/ 4x4x3	1,440
4/ 3x2x2½	450
10 small glass reserve tanks	150
	<u>10,685</u>

Reservoirs 10,000

c. Cold water

Exhibit Tanks

1/ 11x8x6	3,300
3/ 8x6x5	5,400
5/ 4x3x3	1,800
12/ 3x2x2½	1,350
	<u>11,850</u>

Reserve Tanks

1/ 12x8x6	4,320
2/ 8x6x5	3,600
1/ 6x5x5	1,125
4/ 4x4x3	1,440
4/ 3x2x2½	450

**Reserve Tanks**

1/ 12x8x6	4,320
2/ 6x5x5	2,250
4/ 4x4x3	1,440
4/ 3x2x2 $\frac{1}{2}$	450
	<u>8,460</u>

**Reservoirs**

25,400

**B. Salt Water**

**a. Warm water**

**Exhibit Tanks**

2/ 13x10x6	11,700
1/ 11x8x5	3,300
1/ 8x6x5	1,800
1/ 6x5x5	1,125
4/ 4x4x3	1,440
10/ 3x2x2 $\frac{1}{2}$	1,125
	<u>20,490</u>

1 large floor tank for sharks, rays, etc.

38,600

69,090

**Reserve Tanks**

1/ 12x8x6	4,320
2/ 8x6x5	3,600
3/ 6x5x5	3,375
8/ 4x4x3	2,880
10/ 3x2x2 $\frac{1}{2}$	1,125
	<u>15,300</u>

**Reservoirs**

86,500

**b. Temperature water**

**Exhibit Tanks**

2/ 13x10x6	5,850
2/ 11x8x5	6,600
1/ 8x6x5	1,800
1/ 6x5x5	1,125
4/ 4x4x3	1,440
8/ 3x2x2½	900
	<u>17,715</u>

1 large floor tank for harbor seals and other species	38,600
1 large floor tank for sea lions	92,000
1 large floor tank for porpoises	100,000

**Reserve Tanks**

1/ 12x8x6	4,320
2/ 8x6x5	3,600
2/ 6x5x5	2,250
6/ 4x4x3	2,160
10/ 3x2x2½	1,125
	<u>13,455</u>

<b>Reservoirs</b>	164,000
-------------------	---------

**c. Cold water**

**Exhibit Tanks**

1/ 13x10x6	5,850
2/ 8x6x5	3,600
3/ 6x5x5	3,375
4/ 4x4x3	1,440

11/ 3x2x2½	1,237.5
	<u>15,502.5</u>
1 large floor tank for penguins	38,600
	<u>44,102.5</u>
<b>Reserve Tanks</b>	
1/ 12x8x6	4,320
2/ 8x6x5	3,600
1/ 6x5x5	1,125
5/ 4x4x3	1,800
8/ 3x2x2½	900
	<u>11,620</u>
<b>Reservoirs</b>	57,100

Both open and closed systems will be used for water circulation. The open systems are used for supplying water without heating or cooling. Most of the temperate water tanks will have supply from open systems as species living in the temperate climate usually can tolerate greater temperature change.

Total capacity of reservoirs is 364,000 gallons. Gravity tanks of total capacity 19,200 gallons are to be provided.

The total number of exhibit tanks excluding the small glass tanks is 125, approximating 138 in the Shedd Aquarium in Chicago.

- (3) Public area for viewing exhibit tanks
- (4) Service area for tanks
- (5) Mechanical equipments such as pumps, heating and refrigerating machines, air ventilators, and air compressors.
- (6) Meeting room for public and staff, about 600 s.f.
- (7) Lecture room about 2,200 s.f.
- (8) Library about 1,500 s.f. and work space
- (9) Cafeteria about 1,500 s.f. with kitchen about 400 s.f.
- (10) Laboratory about 600 s.f.
- (11) 3 offices for curator, assistants and secretaries about 400 s.f. each and waiting room of about 400 s.f.
- (12) Staff room about 400 s.f.
- (13) Staff lavatories and showers with lockers
- (14) Workshop for dry exhibits and maintenance
- (15) Gallery for dry exhibits
- (16) Storage rooms

## CHAPTER XVI REPORT ON DESIGN

The building is mainly of reinforced concrete because of its fire resistant quality, durability, ease of maintenance and flexibility offered to planning. It is also used for the construction of tanks. The large roof areas over the large floor tanks, and the main exhibition area are spanned by steel trusses for lighter construction. The ribs subdividing the exterior bays are of precast concrete units.

The skylights over the large floor tanks have baffles so arranged that most of the light will fall only directly over the tanks.

The circulation is planned on the basis that all the exhibits at different floors can be covered by the visitors in one continuous route.



## BIBLIOGRAPHY

1. Atz, James W. Functions of a Laboratory in a Public Aquarium. Parks & Recreation, 31 (9) : 525-529, 1948
2. Coates, C. W. Planning a Public Aquarium. Parks & Recreation, 31 (12) : 735-739, 1948.
3. Coates, C. W. and J. W. Atz Lighting the Tank in a Public Aquarium. Parks & Recreation, 32 (8) : 480-485, 1949
4. Kähler and Luckhardt Lighting in Architecture. English translation 1959, Reinhold Publishing Corporation
5. Olko, H.A. A New Aquarium for Boston. Thesis, M. Arch., M.I.T., 1953
6. Townsend, C. H. Guide to the New York Aquarium. New York Zoological Society, 1937
7. Chute, W. H. John G. Shedd Aquarium.
8. Amos, W. H. Marine Life. Nelson Doubleday, Inc. 1959
9. Zoological Gardens Frankfurt am Main Zoo Frankfurt Exotarium, English Edition. 1958
10. New York Zoological Society The New York Aquarium. 1957
11. New York Zoological Society The New York Aquarium on the Ocean Front. 1957
12. Newman, M. A. Guide to the Vancouver Public Aquarium. Vancouver Public Aquarium Association

13. California Academy of Sciences Guide to the Steinhart Aquarium. 1947
14. Miami Seaquarium Sea Wonders of the World. 1958
15. Waseda University Nagasaki Aquarium. (Japanese)
16. Oceanarium. Progressive Architecture, 36: 106-11, October, 1955
17. The Lily Ackerland Fleishmann Memorial Aquarium. Architectural Record, 110: 138-40, October, 1951
18. Vancouver Public Aquarium. The Royal Architectural Institute of Canada Journal, 33; 373-5, October, 1956



CITY OF BOSTON  
 PARKS AND RECREATION DEPARTMENT  
 33 BEACON STREET  
 BOSTON 8, MASS.

November 16, 1959

Mr. Donald Tsao  
 314 Harvard Street  
 Cambridge, Mass.

Dear Sir:

This will acknowledge your communication of November 16, regarding the thesis you are developing on an aquarium in Boston. The City of Boston Aquarium was closed some four years ago and there is no plans for the reopening of it in the immediate future. If an aquarium was to be constructed, it would be more or less metropolitan in character and would come under the jurisdiction of the Metropolitan District Commission. The Boston Aquarium proved, in recent years, to be an expensive undertaking due to the fact that it was almost impossible to obtain the proper type fish for exhibit and then the added expense.

New York City closed the aquarium at the Battery but have recently constructed a small one in Central Park. The Shedd Aquarium in Chicago is one of the finest in the world and is entirely operated from the proceeds of a special trust fund. The expense of operating an aquarium from city tax revenue in these days is almost an impossible task, and that is why I say that if one were to be built in Boston, it would be by the Metropolitan District Commission.

I would suggest that you write to Mr. John Maloney, Commissioner of the Metropolitan District Commission, 20 Somerset Street, Boston.

Very truly yours,

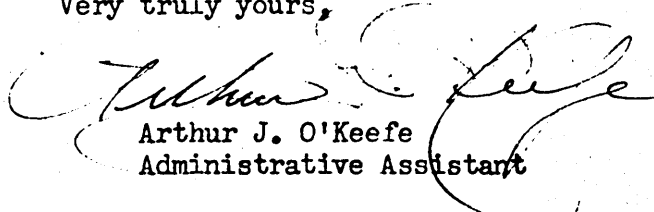
  
 Arthur J. O'Keefe  
 Administrative Assistant

AJO/e



*The Commonwealth of Massachusetts*  
*Metropolitan District Commission*

Franklin Park Zoological Gardens

Boston 21, Massachusetts

Walter D. Stone  
Director

December 7, 1959

Mr. Donald Tsao  
314 Harvard Street  
Cambridge, Massachusetts

Dear Mr. Tsao:

Your letter of November 26 to Commissioner John E. Maloney, has been referred to this office. Rather than attempting a detailed answer to your aquarium proposal in this letter, I would suggest you phone me at the Franklin Park Zoo. We could then arrange a meeting for discussion. Our phone number is JAmAica 2-2370.

Truly yours,

MET. DIST. ZOOL. GARDENS

  
Walter D. Stone  
Director

WDS:PE

STADT FRANKFURT AM MAIN  
DER MAGISTRAT

# ZOOLOGISCHER GARTEN

Postscheckkonto: 148518 Frankfurt a.M.  
Fernsprechananschluß: 20221  
Nebenanschlüsse: Direktion 3727  
Verwaltung 3730  
Tierabteilung 3728  
3937  
Exotarium 3732  
Werbung 3729

FRANKFURT A. M., den February 29, 1960  
Alfred-Brehm-Platz 16

## AIRMAIL

Mr. Donald Tsao  
314 Harvard Street  
Cambridge, Mass.  
U. S. A.

Ihr Zeichen:

Ihre Nachricht vom: **Dec. 22, 1959**

Unser Zeichen: **Z/rmr**

Im Antwortschreiben  
bitte angeben

Betr.:

Dear Mr. Tsao,

Unfortunately we still do not have received the blue prints for some groundplans of the Exotarium in order to send them to you for your studies.

We would like to mention in advance that you may use these plans only up to a limited extent as model for a new building as our Exotarium has been erected on the substructure of the old Aquarium which was built already in 1878. Therefore you will find quite a few compromises which were necessary as the old parts, vaults, and cisterns had to be used.

A detailed task about the Exotarium and its techniques has not yet been published. It would mean to write a voluminous book to answer all your questions in full length. We therefore have to content our-selves to send you a copy of our Exotarium-guide in English by separate mail. You will find summarized statements in there about the volume of the tanks, technical data etc.

The use of the statements about the receipts and expenditures is also very limited to you: the entrance fees can hardly be used since the costs for the maintenance of such a plant and the payment of the employees is entirely different in your country. One year after the re-opening of the Exotarium we had more than a million visitors. This high number of visitors can certainly not be kept permanently. The attraction of the latest novelty has brought the number of visitors up to this height. At present 2/3 of the people visiting the Zoological Gardens are also visiting the Exotarium. The total expenses and receipts amount to ca. DM 500.000.- yearly.

Yours faithfully

(Dr. B. Grzimek)

HARRISON & ABRAMOVITZ  
ARCHITECTS

630 FIFTH AVENUE, NEW YORK 20, N. Y

WALLACE K. HARRISON  
MAX ABRAMOVITZ

CHARLES H. ABBE  
MICHAEL M. HARRIS  
JOHN J. HEALY  
GEORGE S. JOHNSTON

January 13, 1960

Mr. Donald Tsao  
314 Harvard Street  
Cambridge, Massachusetts

Dear Mr. Tsao:

I am sorry it has taken me so long to answer your letter of January 1, 1960. I have been trying to relocate information re aquarium program which you requested in your letter, but we have been unable to find any trace of a program, and as I recall, there never was any written program set up. The only thing I can do to help you is to outline a program as I remember the requirements, and send you plans of the aquarium as it was laid out at the time of its inception.

At the moment, I can say this much: The requirements were for five halls or exhibition areas: two to be used for fresh water fish and two for salt water fish. The two fresh water would be for (a) Tropical fresh water, (b) Temperate fresh water. The two tropical salt water halls were for (a) Tropical salt water, (b) Temperate salt water. The fifth area was used for another exhibition; the type of exhibition has escaped my mind. Two outdoor pools were included for the exhibiting of porpoises, seals, sea lions, etc.

Provisions also had to be made for a reserve storage of water for every pool in the exhibition areas. Provisions for the various personnel, including the aquarist and the caretakers are essential; cafeteria and dining areas are necessary for both the public and the personnel. Carpenter and repair shops, and a laboratory for study and research were required.

There may be other information that I do not recall at the moment, but I would advise you to contact an aquarist of any of these large aquariums that have been built to get more detailed and better information. Dr. C. W. Coates, The Aquarium, Boardwalk at West 8th Street, Brooklyn 24, New York, has a great knowledge of these requirements.

I hope this information will be of help to you. If you have any specific questions, please do not hesitate to write to me.

Sincerely yours,  
HARRISON & ABRAMOVITZ

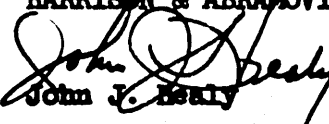
  
John J. Healy

JJH/nb

xvi

CALIFORNIA ACADEMY OF SCIENCES

GOLDEN GATE PARK : SAN FRANCISCO 18, CALIFORNIA

TELEPHONE BAYVIEW 1-5100

THE SCIENCE MUSEUM

THE ALEXANDER F. MORRISON PLANETARIUM

THE STEINHART AQUARIUM

January 15, 1960

Mr. Donald Tsao  
314 Harvard Street  
Cambridge, Massachusetts

Dear Mr. Tsao:

I have your recent letter requesting information about Steinhart Aquarium in connection with the preparation of your thesis on an Aquarium for Boston. Plans and specifications for the rehabilitation of Steinhart Aquarium were today submitted by the architect to the City of San Francisco. At a later date I can send you some copies of pertinent sections of the blueprints, if you so desire.

In the meantime, I am sending you a copy of our guidebook under separate cover. It is due for drastic revision when the rehabilitation is completed, but it may contain some information of the type you need in the front section.

Sincerely yours,



Earl S. Herald  
Curator of Aquatic Biology  
Steinhart Aquarium

ESH:pjc

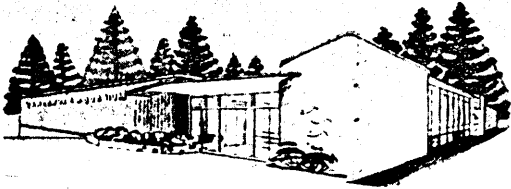

## VANCOUVER PUBLIC AQUARIUM ASSOCIATION

PRESIDENT: FRANK R. BUTLER  
CURATOR: M. A. NEWMAN

BOX 8, STANLEY PARK • VANCOUVER 5, B.C.  
MUTUAL 4-3433

February 9, 1960

Mr. Donald Tsao  
314 Harvard St.  
Cambridge, Massachusetts

Dear Mr. Tsao:

I am sending you a copy of our guide book in a separate envelope. It gives information which will answer most of your questions.

Sincerely yours,

Murray A. Newman  
Curator

MAN/hm





# MARINELAND OF THE PACIFIC

OWNED AND OPERATED BY OCEANARIUM, INC.  
PALOS VERDES ESTATES, CALIFORNIA  
TELEPHONE • FRONTIER 7-1571 • OREGON 8-2410

HENRY U. HARRIS  
*President*  
WILLIAM F. MONAHAN  
*Vice President  
& General Manager*

February 10, 1960

Mr. Donald Tsao  
314 Harvard St.  
Cambridge, Mass.

Dear Mr. Tsao:

In reply to your letter asking for Marineland information for the thesis you are writing on aquariums, we are enclosing a Marineland fact sheet and several photographs that may be useful to you. However, we are unable to supply you with plans of the oceanarium, or sections of it. If you require detailed information the architectural firm of Pereira & Luckman that designed Marineland may be able to help you. The address of the successors to this firm is:

/ Charles Luckman Associates  
9220 Sunset Blvd.  
Los Angeles, Calif.

Cordially yours,

Helen Danzis  
Public Relations Department

hd:s  
encs.

C O P Y

Willard Welsh & Col, Inc.  
REAL ESTATE  
45 Bromfield Street, Boston 8, Mass.

February 25, 1960

Mr. Donald Tsao  
314 Harvard Street  
Cambridge, Massachusetts

Dear Mr. Tsao:

This is to acknowledge your letter of February 19 on the subject of your proposed thesis on an aquarium.

We do not own the land that you refer to near Columbus Park, but we have been agents for the owners in recent years. I am afraid that I am not going to be able to provide you with some of the information which you desire, but I will try to suggest some thoughts on the matter.

With regard to a plan of the land, I think you may be able to satisfy yourself in this regard by referring to the Assessors Plan at Boston City Hall. We do not have topographical land plans and our surveys are not available for general distribution.

As you can see the land is largely level. Much of it is filled and the same is true of a great deal of the land in that vicinity. The site in which we are interested has approximately 900,000 sq. ft. of filled land and extends out to the waterfront on Dorchester Bay.

I am not at liberty to quote a price on this land at the present time since it is temporarily off the market, but I think that you will find sales of other land in the neighborhood have run from 50¢ to close to \$1.00 per sq. ft. during recent years. You should understand that prices vary substantially depending upon size of lot purchased, street frontage, availability of railroad siding, and so forth.

The Columbia Circle area does, of course, have the advantages of rapid transit and excellent highway approaches.

You can buy a topographical plan of the area Hammett's on Tremont Street in Boston quite inexpensively. General information relative to land sites in the City can normally be easily had of the Chamber of Commerce. I wish you success in your thesis.

Very truly yours,

Willard Welsh & Co., Inc.

Philip B. Gates

PBG/jm

# MARINE STUDIOS

MARINELAND

ST. AUGUSTINE

FLORIDA



14 March 1960

Mr. Donald Tsao  
314 Harvard Street  
Cambridge 39, Massachusetts

Dear Mr. Tsao:

While we would like to be able to comply with your request, this is quite a large order.

We have never endeavored to compile this information as the time and expense involved would be too great.

Enclosed is a brochure which may prove of some value to you.

Sincerely yours,



W. F. Rolleston  
Vice President & General Manager

WFR:lda

enclosure



*Marine Wonders*



# SEASIDE AQUARIUM

SEASIDE, OREGON

March 21, 1960

Mr. Donald Tsao  
314 Harvard Street  
Cambridge, Mass.

Dear Sir:

We have your letter of March 15th and will answer it to the best of our ability.

We are enclosing a booklet and pamphlet describing our aquarium. Our supply of fishes are all obtained along the Oregon Coast ocean and bays. We are sorry we are not at liberty to give you the number of employees and maximum traffic of visitors.

We sincerely hope the booklet will help you in preparing your thesis.

Yours very truly

SEASIDE AQUARIUM

By *Mrs. A. W. Ensor*  
Mrs. A. W. Ensor, Mgr.



Greater Miami's Fabulous

# SEAQUARIUM

EMerson 1-5471

RICKENBACKER CAUSEWAY • MIAMI

March 22, 1960

Mr. Donald Tsao  
314 Harvard Street  
Cambridge, Massachusetts

Dear Mr. Tsao:

Enclosed herewith is a copy of our Seaquarium guide book and one of our brochures which you requested in your letter of March 15th.

Our main tank is 80 feet in diameter with shell height 18 feet. The glass windows are 20 inches by 42 inches in size. There are two glass panes in each window. The lower glasses are each  $5/8$  inch thick while the upper glasses are  $3/8$  inch.

I hope this information will be of some help to you in preparing your thesis.

Sincerely yours,

MIAMI SEAQUARIUM

C. H. Ball  
Managing Director

CHB/vw  
Encs-Guide Book  
Brochure



NAGASAKI TOURIST PROMOTION COMPANY

3-3 Daiba-cho  
(4th Floor, Nagasaki Building)  
Nagasaki, Japan

April 2, 1960

Dear Mr. Tsao:

I am extremely sorry for this belated reply to your letter of January 26. On the other hand it is my pleasure to express my appreciation to you for your interest toward our aquarium, which is our pride and honor. Needless to say it is the biggest one in the East and is equipped with the most up to date equipment. The building too has all the modern cream of architectural science in the house at the same time it preserves the Oriental sedateness.

I have enclosed the translated literature and also the original booklet in Japanese. I sincerely hope they will meet your satisfaction.

It is my sincere hope that your thesis will be a successful one.

With my warmest personal wishes.

Very sincerely,

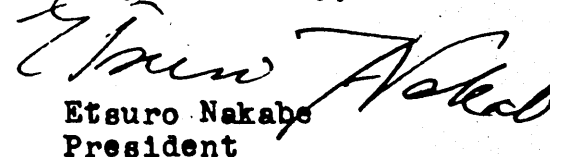
  
Etsuro Nakabe  
President

Mr. Donald Tsao 314 Harvard Street  
Cambridge  
Massachusetts  
U. S. A.



· JOHN · G · SHEDD · AQUARIUM ·

1200 SOUTH LAKE SHORE DRIVE  
CHICAGO 5, ILLINOIS

WALTER H. CHUTE  
DIRECTOR

April 20, 1960

Mr. Donald Tsao  
314 Harvard Street  
Cambridge, Massachusetts

Dear Sir:

We are sending herewith a pamphlet on the Shedd Aquarium. It will answer most of the questions in your letter. The Shedd Aquarium is exclusively an exhibition institution. We do not do any research; nor do we have lecture programs. We believe the function of a public Aquarium is to provide visual education by the continuous display of as many forms of aquatic life as are obtainable.

Shedd Aquarium is situated in Grant Park and the parking facilities, provided by the Park Department, are shared with other institutions.

Very truly yours,

*Walter H. Chute*  
Director

WHC/mod

Encl.

GOLDSTONE & DEARBORN • ARCHITECTS

1270 AVENUE OF THE AMERICAS, NEW YORK 20, N. Y. • CIRCLE 7-1237

HARMON H. GOLDSTONE, AIA  
EUSTIS DEARBORN, AIA

April 25, 1960

Mr. Donald Tsao  
314 Harvard Street  
Cambridge 39, Mass.

Dear Mr. Tsao:

I'm sorry that we have no photographs or plans  
available for you of the New York Aquarium.

Good luck with your thesis.

Very truly yours,

GOLDSTONE & DEARBORN

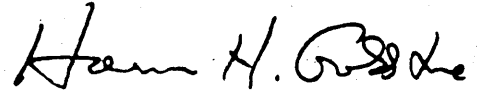

Harmon H. Goldstone

HHG:S



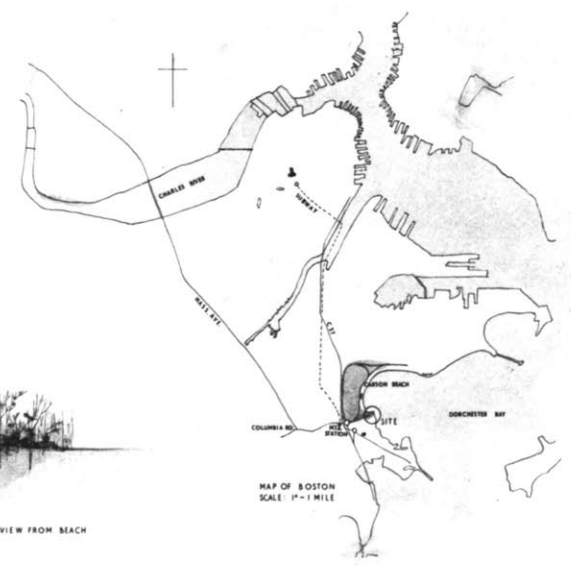
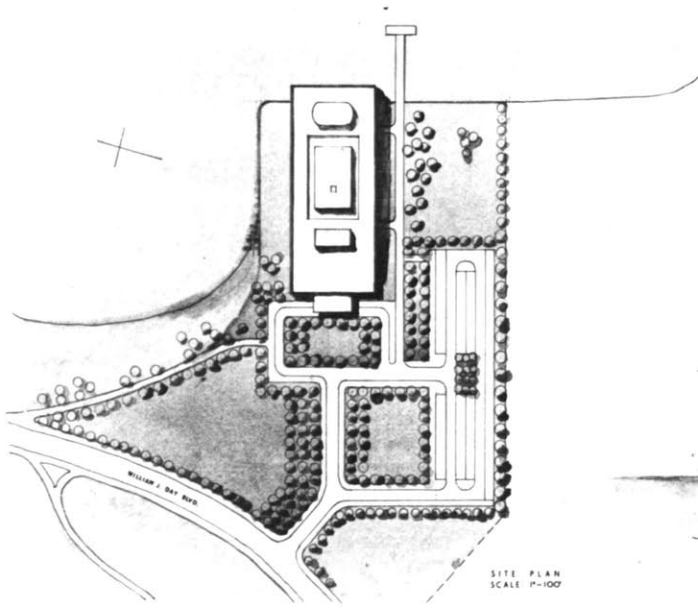

**AN AQUARIUM FOR BOSTON**  
 THESIS MAY 1960 TSAO

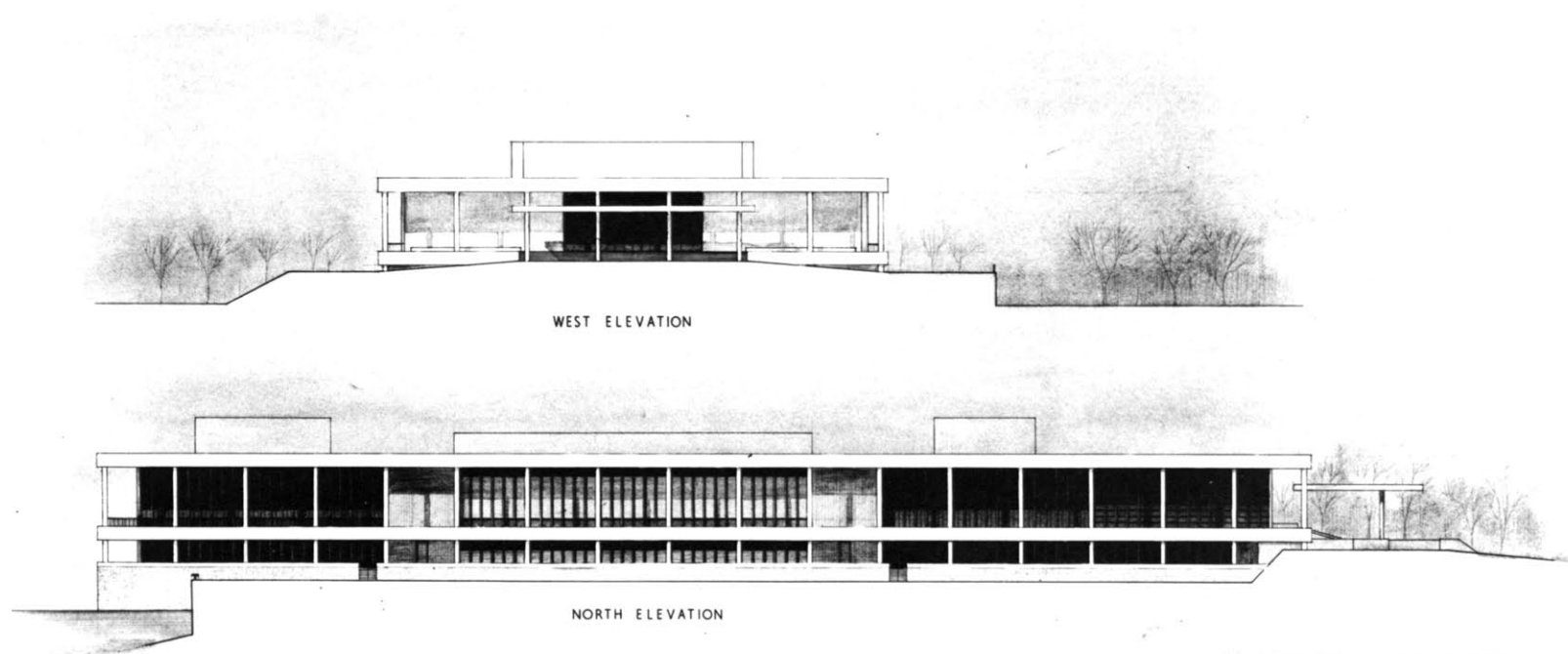

WEST ELEVATION

NORTH ELEVATION

AN AQUARIUM FOR BOSTON  
THESIS MAY 1960 SCALE 1" = 16' TSAO

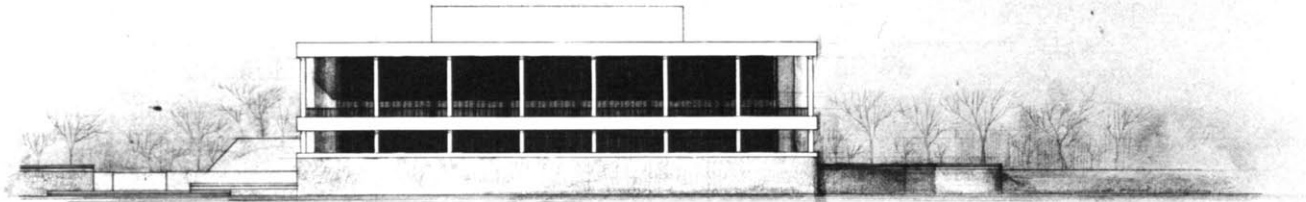

EAST ELEVATION

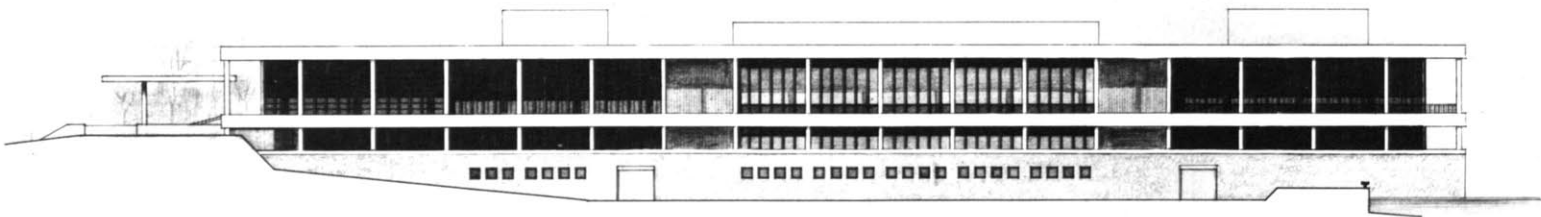

SOUTH ELEVATION

AN AQUARIUM FOR BOSTON  
THESIS MAY 1960 SCALE: 1" = 16' T.SAO

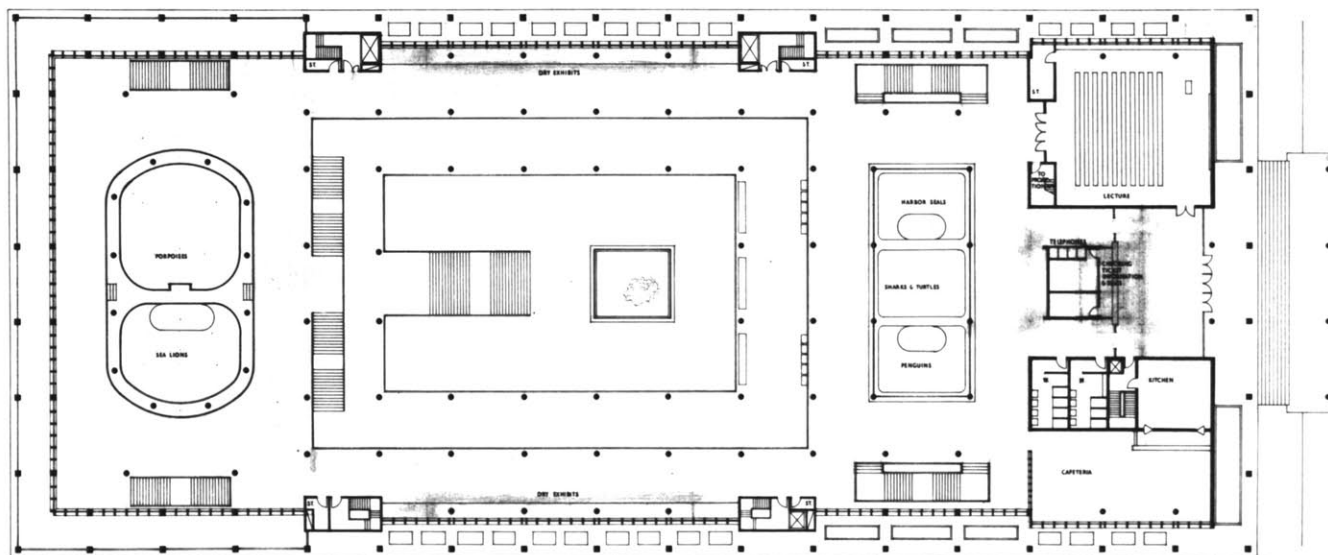

TOP FLOOR PLAN

AN AQUARIUM FOR BOSTON  
 THESIS MAY 1960 SCALE 1"=16' TSAO

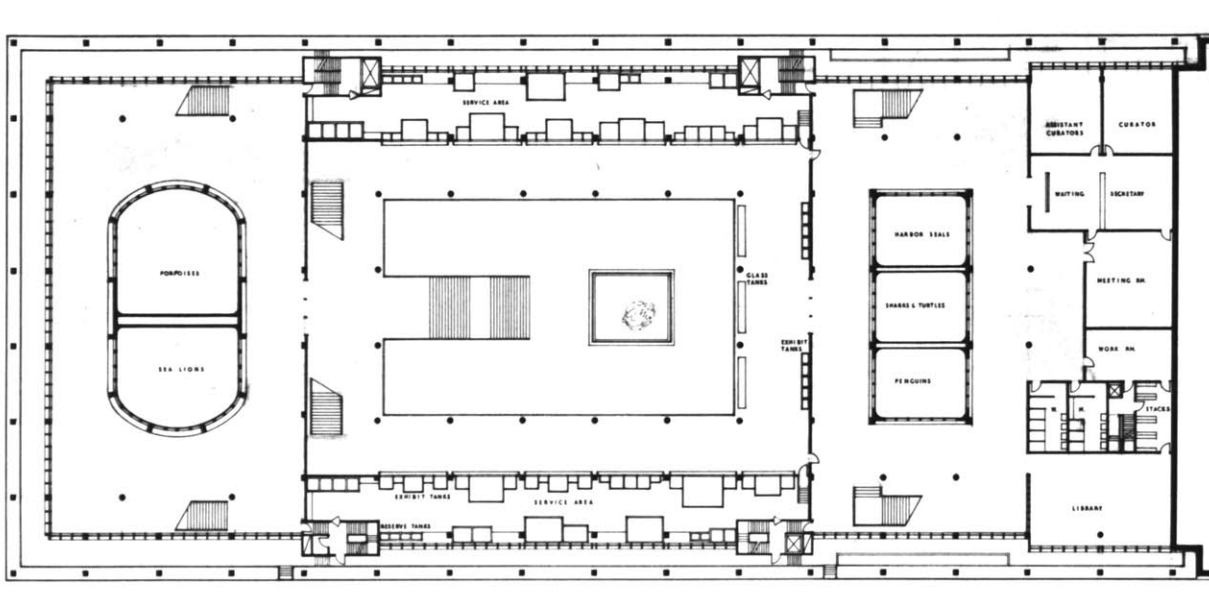

FIRST FLOOR PLAN

AN AQUARIUM FOR BOSTON  
 THESIS MAY 1960 SCALE: P-16' T5A0

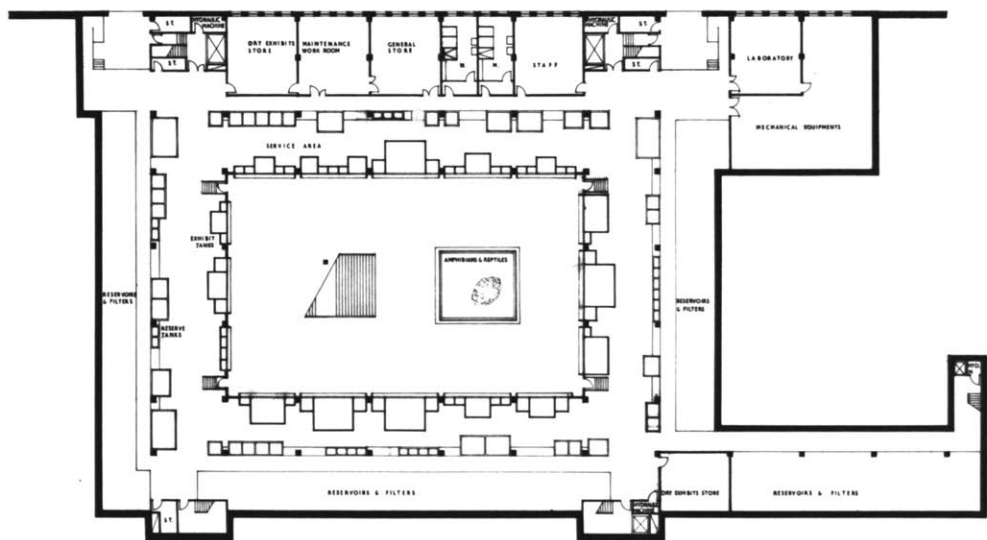

BASEMENT FLOOR PLAN

AN AQUARIUM FOR BOSTON

THESIS MAY 1960 SCALE: 1"=16' TSAO

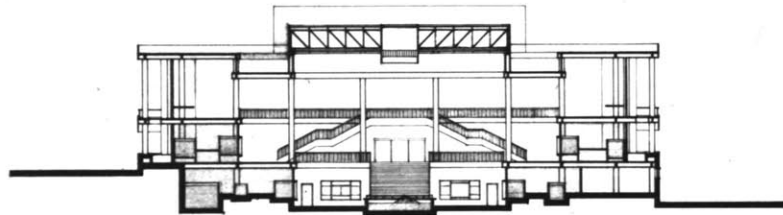

CROSS-SECTION

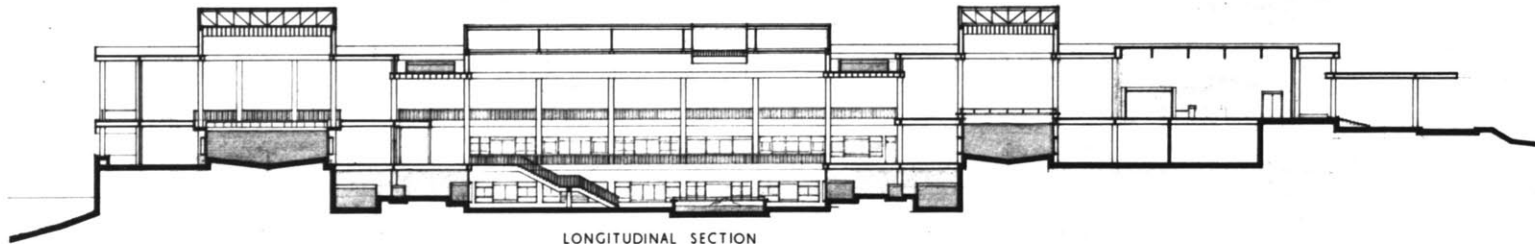

LONGITUDINAL SECTION

AN AQUARIUM FOR BOSTON  
THESIS MAY 1960 SCALE: 1" = 16' TSAO