



REINFORCED CONCRETE.  
MODULAR ROOF UNIT.

By

Shafik I. Rifaat.

B.Arch. Alexandria University, 1960.

SUBMITTED IN PARTIAL FULFILLMENT  
OF THE REQUIREMENTS FOR THE  
DEGREE OF MASTER IN ARCHITECTURE  
AT THE  
MASSACHUSETTS INSTITUTE OF TECHNOLOGY  
JULY 1962.

Signature of Author

Shafik I. Rifaat.

Signature of Thesis Supervisor

Prof. Eduardo F. Catalano.

Signature of Head of Department,

Prof. Lawrence B. Anderson.

July 27, 1962.

Pietro Belluschi, Dean  
School of Architecture and Planning  
Massachusetts Institute of Technology  
Cambridge 39, Massachusetts.

Dear Dean Belluschi :

In partial fulfillment of the requirements for the degree of Master in Architecture, I hereby submit this thesis entitled, " Reinforced Concrete Modular Roof Unit."

Respectfully,

---

Shafik I. Rifaat.

## ACKNOWLEDGEMENTS

I should like to thank the following  
for their advice and criticism during  
the course of this study

Professor Eduardo F. Catalano  
Massachusetts Institute of Technology

and

Professor Howard Simpson  
Professor Giulio Pizzetti  
Professor A. G. Harris.

TABLE OF CONTENTS

Page

Program . . . . .	.1
Introduction . . . . .	2
Objectives . . . . .	3
Structural System . . . . .	.4
Final study . . . . .	.7
Structural analysis . . . . .	.10
Design of different parts . . . . .	.13
Quality of spaces . . . . .	.25
Admittance of light . . . . .	.25
Ventilation . . . . .	.27
Acoustics . . . . .	.27
Thermal insulation . . . . .	28
Subdivision of space . . . . .	29
Construction . . . . .	30
Conclusion . . . . .	31

REINFORCED CONCRETE MODULAR ROOF UNIT.

By

Shafik I. Rifaat.

Submitted in partial fulfillment of the requirements for the degree of Master in Architecture in the Department of Architecture, on July 27, 1962.

Program.

THE USE OF REINFORCED CONCRETE :

Project C. Design of a MODULAR ROOF UNIT for schools, shopping centers, or other one-story buildings.

Span : from 30 to 40 feet.

Space defined by a peripheral low horizontal area, and a central high area of varied forms. Natural and / or artificial light.

## INTRODUCTION

---

Free education, to eradicate ignorance in the developing countries, is a must. In Egypt, there is an urgent and immediate need for primary schools. The number of students, between the ages 6-12 years, in need of primary education, who cannot find schools to accomodate them, are about 1,550,000 students. If we consider a primary school, that has six stages of education, with three classrooms per stage, and 35 students per classroom, then we will need approximatly 2,460 primary schools, each consisting of 18 classrooms, with a total number of 44,300 classrooms.

The aim of this thesis, is to direct the design and the development, of a - modular roof unit, spanning from 9-12 meters, ( 30 - 40 feet), a space defined by a peripheral low horizontal area and a central high one - to form a classroom, self-contained, flexible within itself, to allow and facilitate the teaching and other activities to take place, and to form a system of growth, of which this unit is the component.

## OBJECTIVES

The unit should be designed to suit the Egyptian environment. Both the simplicity of erection, and the lowering of the total cost, without affecting the quality, are essential. There should be maximum usage of natural resources, such as day-light for lighting, and natural air movement for cross-ventilation.

The following studies, have been a useful guide, to reach the final architectonic expression of this unit :

- 1- Structural system
- 2- Quality of spaces
- 3- Admittance of light
- 4- Ventilation
- 5- Acoustics
- 6- Weather insulation
- 7- Subdivision of space
- 8- Construction.

## 1- STRUCTURAL SYSTEM

Structural analyses, based on logical assumptions, have been studied, to attain maximum usage of the space enclosed, and to obtain best performance of the material, Reinforced Concrete. This is achieved through the geometrical arrangement of the surfaces, and the system of supports.

Assumptions :

- The continuity of surfaces is essential; the low horizontal area and the high one, should act together to reduce the stresses in the structure.
- The structure should be carried on four supports, to produce practical spans, and load distribution.
- The logical position of the four supports, is shown in figure -C-, where the columns can support both, the low horizontal area, and the high one, as well as reducing the moments and shearing forces , ( stresses ) , in the structure; as shown in the simple diagrams A, B, and C.
- The proportion of the cantilevers to the main span, should not exceed 1:3:1; this gives equal positive and negative moments under uniform distributed loading.

( Figure 2 , page 5. )



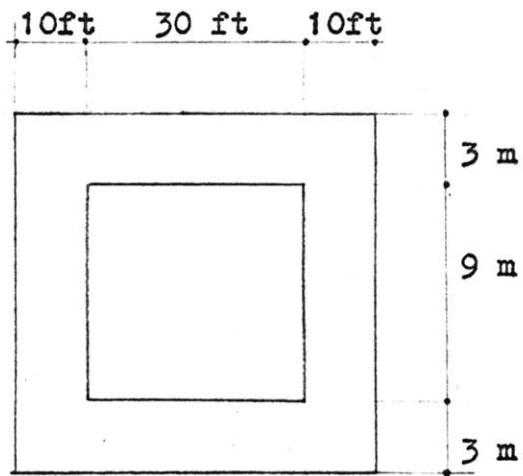

Figure 1

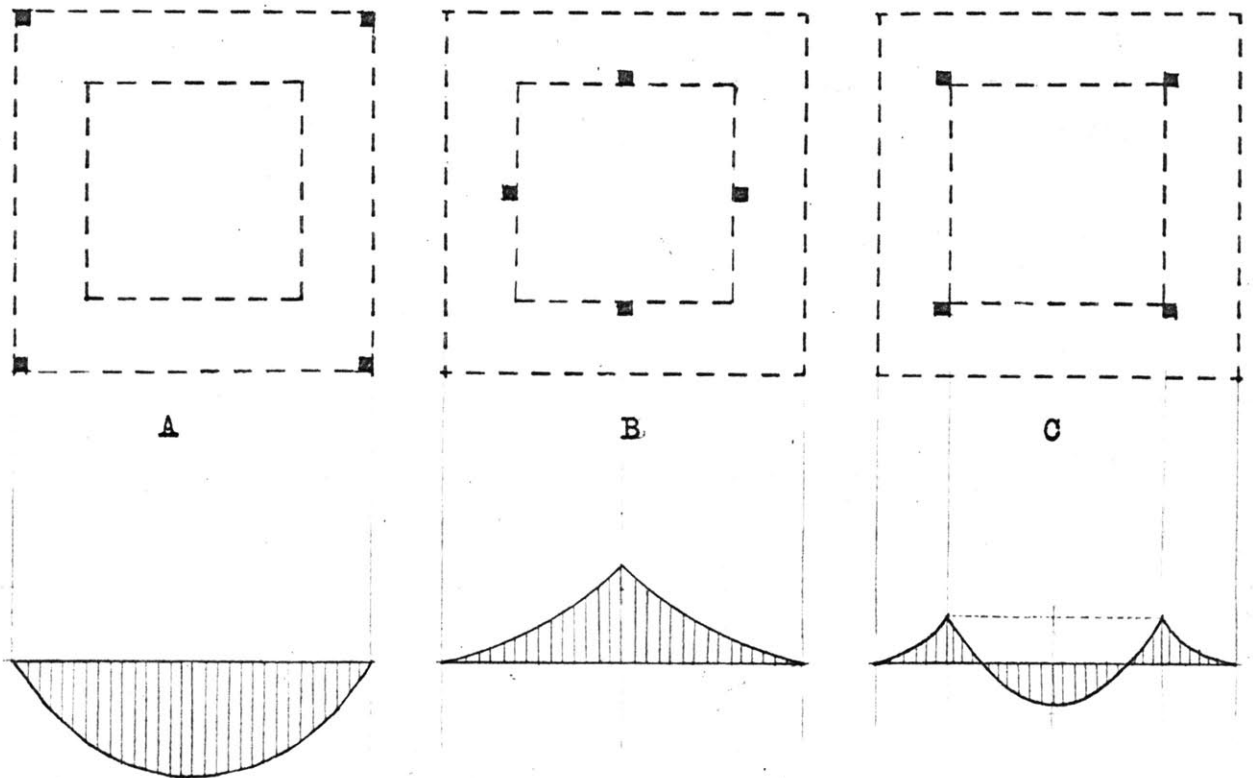
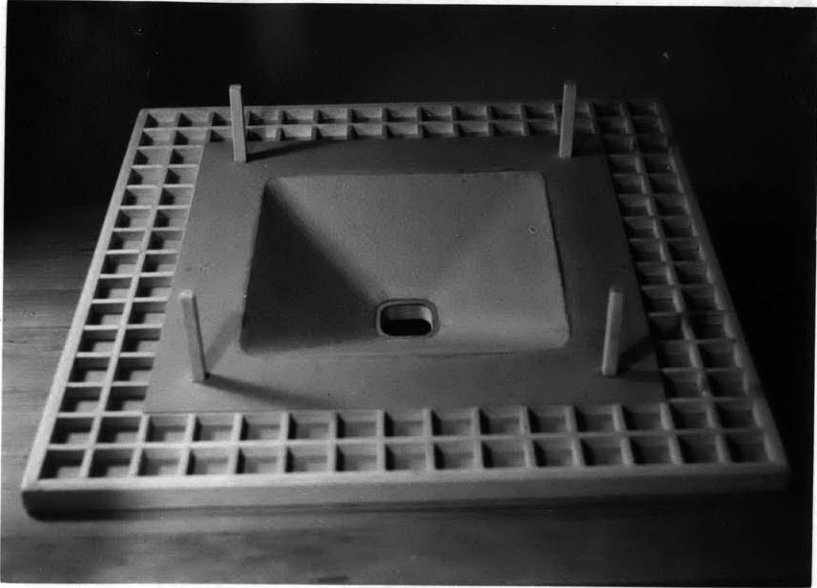
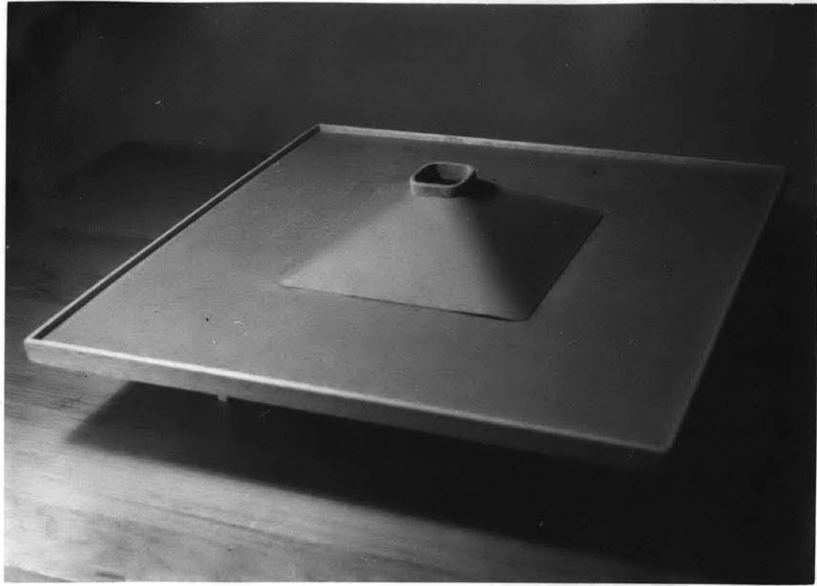
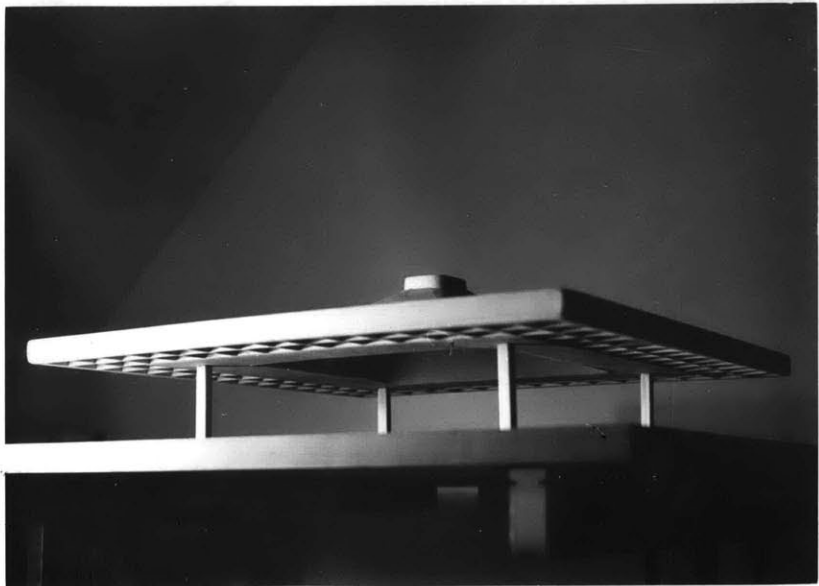

Figure 2



STUDY MODEL



## Final study

### General description :

- A folded plate structure, with the horizontal plate ABC and FGH forming the peripheral low area, and the inclined plate CD and EF forming the pyramidal major space. ( As seen in section on page 11 ).
- Parts AB and GH form a waffle system, of 1 meter (3feet) grid, with a depth of 25 centimeters ( 10 inches ).
- Parts BC and FG are a solid slab, of 1.80 meter ( 6 feet ) in width, and 25 centimeters in depth( 10 inches ).
- The structure is supported on four columns, located at a set-back of 80 centimeters,( 2 feet 10 inches ), from the four corners of the pyramidal roof.

### Structural behaviour :

The folded plate action will occur, as the pyramidal slab CD will act as a deep beam, to resist the inclined force  $F_i$ ; the horizontal slab ABC will act as a tie ring to resist the horizontal force  $F_h$ .

Both ABC and CD, as a folded plate will prevent the movement of point C.in space. ( Figure 20 , page 20 )

### Load distribution :

Assumptions of load distribution between the low horizontal

area and the high one, have been calculated in previous studies to determine the behaviour of the structure under different loading conditions.

The final load distribution is calculated in proportion to the deflections at points of maximum moments.

The horizontal slab ABC is directly supported on the columns, calculations of the deflections at points 1,2 and 3, are made to determine the load distribution between parts AB and BC. ( diagram 3 page 11 ).

Beam A will transfer the load it receives from part AB, to the columns, through the three cantilevers running over the column, and carrying beam A itself. ( diagram 13 page 18 ).

It is assumed here, that the solid slab ( flat beam ) BC, will carry 35% of it's own weight, plus the load it receives from part AB. This load is transferred directly to the columns. At the same time, part BC will resist the twisting moments of the cantilevers, hence reducing the negative moments at the edge C.

The positive moments between the columns, occurring at part BC due to 35% of the load, previously mentioned, will be reduced by the over-hangs at both sides. ( figure 15 on page 18 ).

The remaining 65% of the load from part ABC, plus the

vertical component of load from the pyramidal roof, will form reaction R at point C; this force R will be resisted by the folded plate action of ABC and CD. ( diagram 20 on page 20 )

The pyramidal roof slab has been designed, assuming that it is fixed at the base and two sides, with the high edge simply supported. The coefficient of load distribution has been obtained from the American Reinforced Concrete Codes.

The area of the cross-section of the column has been increased, to allow for a drainage pipe, with a diameter of 10 centimeters (.4 inches ).

A simple rectangular foundation is designed to function in poor soil conditions.

Structural analysis:

( Mathematical calculations of the preceeding text.)

Dimensions submitted are by the metric system.

Loading is by the ton.

m = meter.          cm = centimeter.      t = ton.          kg = kilogram.

1 m<sup>3</sup> of reinforced concrete = 2.4 t.

Loading :

Assuming a 25 cms waffle slab for cantilever AB.

6 cms slab	= 0.06 x 1.00 x 2.4	= 0.144 t
12 x 20 cms beam	= 0.12 x 1.00 x 0.20 x 2.4	= 0.056 t
live load		= 0.050 t
insulating material		= 0.050 t
		<hr/>
Total		= 0.300 t/m <sup>2</sup>

Assuming a 25 cms solid slab for BC.

25 cms slab	= 0.25 x 1.00 x 2.4	= 0.600 t
insulating material and live load		= 0.100 t
		<hr/>
Total		= 0.700 t/m <sup>2</sup>

Assuming an average thickness of 7.5 cms

for CD	= 0.075 x 1.00 x 2.4	= 0.180 t
--------	----------------------	-----------

Figure 4

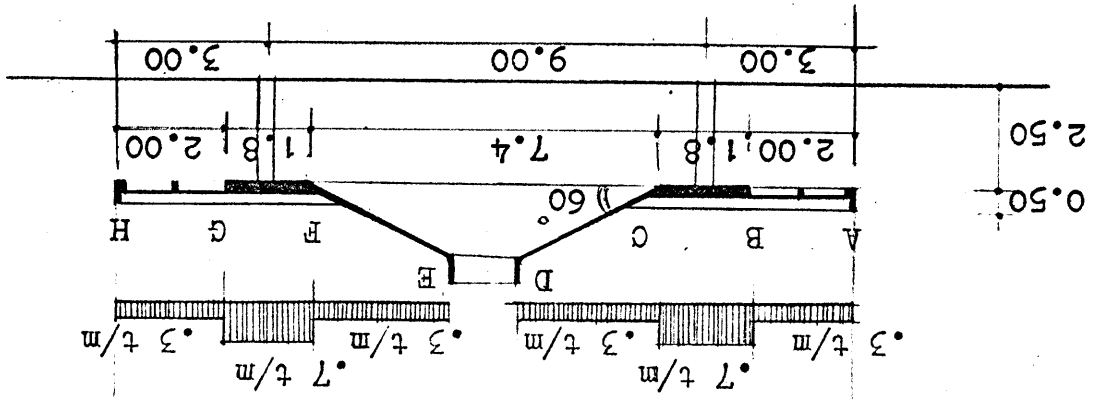
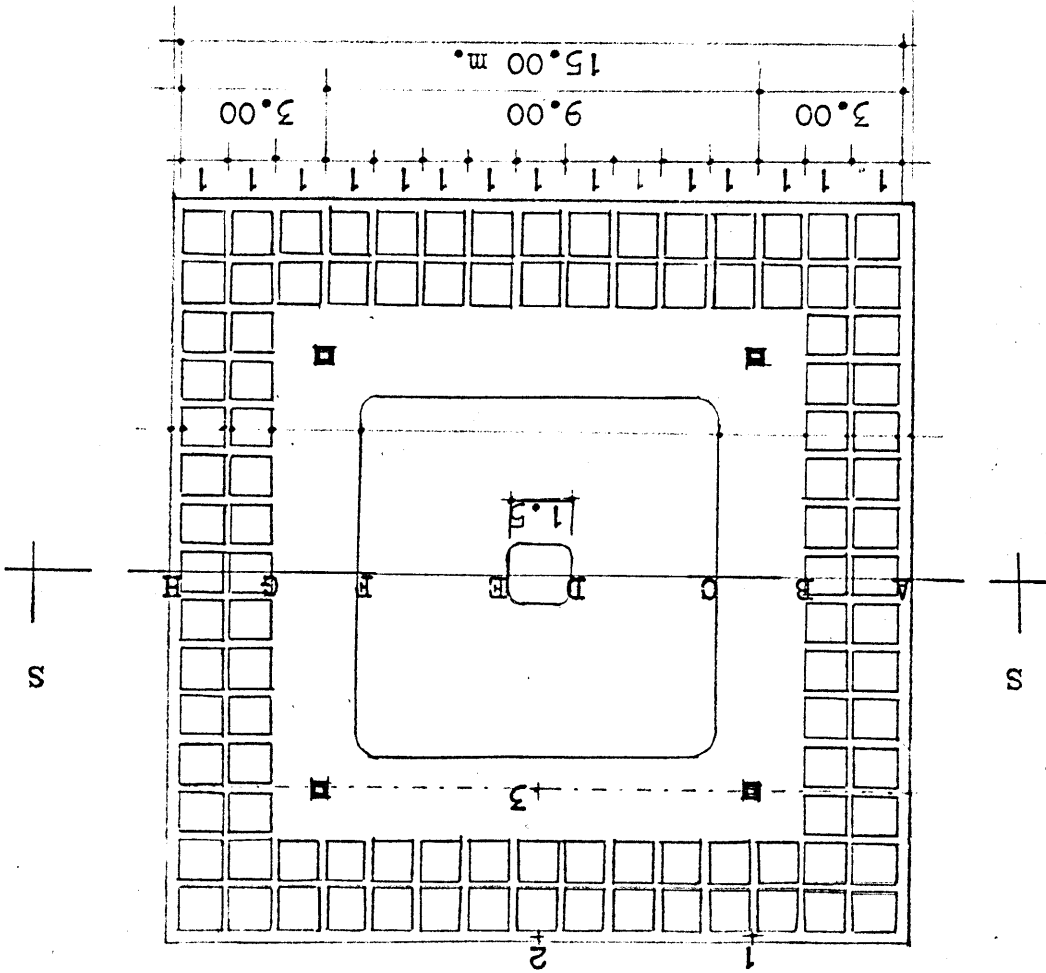

Figure 3



Insulating material and live load		= 0.100 t
		<hr style="width: 10%; margin: 0 auto;"/>
Total		= 0.280 t/m <sup>2</sup>
Horizontal projection		= 0.300 t/m <sup>2</sup>
( figure 4 page 11 ).		

Load distribution:

approximate distribution of load between A and BC, assuming points 2, 3 to have the same rigidity.

Load on point 2 = 0.300 x 1.0 = 0.3 t/m

Load on point 3 = 0.300 + 1.4 x 0.700 = 1.28 t/m

To calculate deflections at mid span of beams A and BC, points 2,3

$$\delta \text{ at 3} = \frac{5}{384} \times \frac{wl^4}{EI}$$

$$I \text{ at 3} = 180 \times \frac{25^3}{12} = 235,000 \text{ cms}^4$$

$$\delta \text{ at 3} = \frac{5}{384} \times \frac{1.28 \times 9^4 \times 10^4 \times 100}{235,000 \times E} = \frac{360}{E} \text{ cms.}$$

To get  $\delta$  at point 2

Load on three cantilevers supporting beam A

$$= 0.300 \times \frac{9.00}{2} = 1.35 \text{ t}$$

Load on one cantilever = 0.45 t

Deflection of end of cantilever at point 1

$$= \frac{0.45 \times 2^3}{3 \times EI}$$



$$\begin{aligned}
I \text{ cantilever} &= \frac{15 \times 25^3}{12} = 19,600 \text{ cms}^4 \\
\delta \text{ at 1} &= \frac{0.45 \times 2^3 \times 10^4 \times 100}{3 \times 19,600} = \frac{61}{E} \text{ CMS} \\
I \text{ at 2} &= \frac{25 \times 25^3}{12} = 32,700 \text{ cms}^4 \\
\delta \text{ at 2} &= \frac{61}{E} + \frac{0.3 \times 9^4 \times 10^4 \times 100}{32,700 \times E} = \frac{660}{E} \text{ cms.} \\
& \text{( figure page )}
\end{aligned}$$

Approximate distribution of load between A & BC

$$\text{Beam A} = \frac{360}{(360+660)} \times 0.3 \times 2.00 = 0.21 \text{ t/m}$$

Assuming that beam BC will gain more rigidity, being connected to rigid beam CD; then beam A will carry less load.

$$= 0.15 \text{ t/m}$$

Approximate distribution of load between BC & CD, assuming beam BC will carry 35% of the load, while beam CD will carry 65% of the load.

$$\text{Load on beam BC} = 0.35(0.7 \times 1.8 + 0.3 \times 2 - 0.15) = 0.60 \text{ t/m}$$

$$\text{Load on Cd from cantilever roof} = 0.65 \times 1.71 = 1.11 \text{ t/m}$$

Assuming distributed load on beam Bc to be triangular

$$P_{\text{max}} = \frac{0.60 \times 2}{1.8} = 0.66 \text{ t/m}$$

Design of different parts:

1- Design of cantilever slab: ( figures <sup>2</sup> page 14 )

$$\begin{aligned}
M_{x-x} &= 0.3 \times 2 \times 2.8 + 0.7 \times \frac{1.8^2}{2} \\
&\quad - 0.15 \times 4.8 - 0.66 \times \frac{1.8^2}{3} \\
&= 1.68 + 1.15 - 0.72 - 0.71 = 1.4 \text{ mt}
\end{aligned}$$

1- Design of cantilever slab

Deflections at 3&2

Figure 5

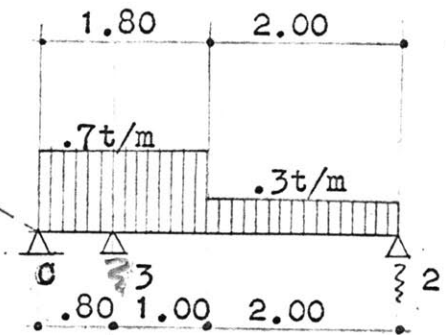

Load distribution

Figure 6

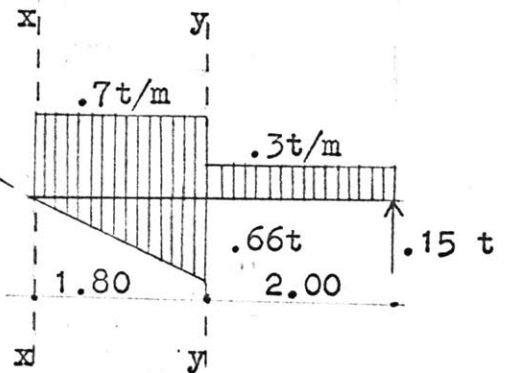

B.M.D.

Figure 7

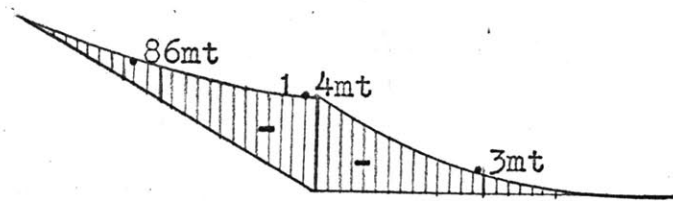

S.F.D.

Figure 8

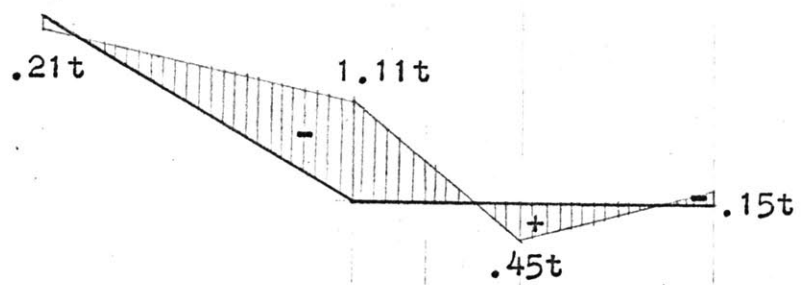

$$\text{Shear}_{x-x} = 1.8 \times 0.7 + 0.6 - 0.15 - 0.6 = 1.11 \text{ t}$$

Design of section x-x

$$d = 0.3 \sqrt{\frac{140000}{100}} = 11.2 \text{ cms}$$

$$t \text{ chosen } 25 \text{ cms} \quad A_s = \frac{140000}{1250 \times 23} = 4.85 \text{ cms}^2$$

$$\text{Chosen } 7 \phi \frac{3}{8} \text{ " } = 4.97 \text{ cms}^2$$

$$\text{Check of shear} = \frac{1110}{100 \times 23 \times 0.87} = 0.555 \text{ Kg/cms}^2$$

$$M_{y-y} = 0.3 \times \frac{2^2}{2} - 0.15 \times 2 = 0.30 \text{ mt}$$

$$\text{Shear}_{y-y} = 0.6 - 0.15 = 0.45 \text{ t}$$

Design of section y-y

$$d = 0.3 \sqrt{\frac{30000}{12}} = 15 \text{ cms.}$$

t chosen 25 cms.

$$A_s = \frac{30000}{1250 \times 23} = 1.04 \text{ cms}^2$$

$$\text{Chosen } 3 \phi \frac{5}{16} = 1.47 \text{ cms}^2$$

$$\text{or } 2 \phi \frac{3}{8} = 1.42 \text{ cms}^2$$

$$\text{Check of shear} = \frac{450}{12 \times 23 \times 0.87} = 1.88 \text{ Kg/cms}^2$$

2- Design of beam A: ( Figures , page 16 )

$$M_{-ve} = \frac{0.15 \times 2^2}{2} = 0.30 \text{ tm.}$$

$$M_{+ve} = 1.125 \times 4.5 - \frac{0.15 \times 7.5^2}{2} = 0.7 \text{ tm}$$

2- Design of beam A.

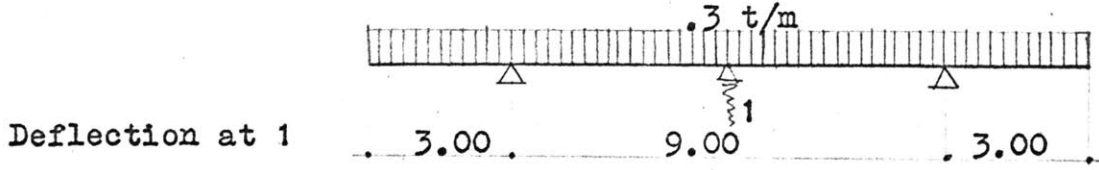

Figure 9

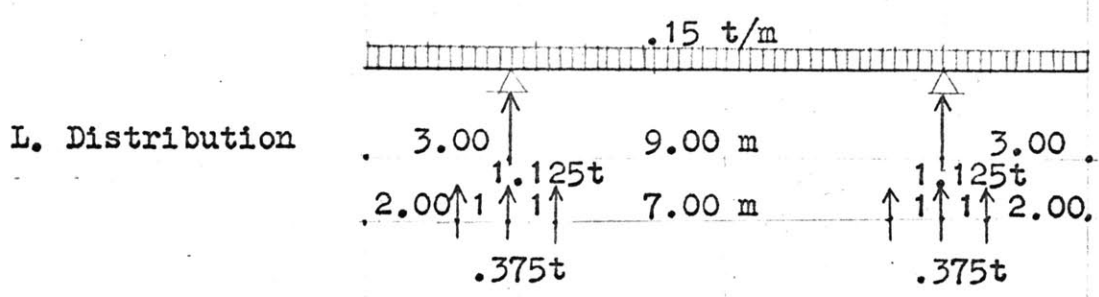

Figure 10

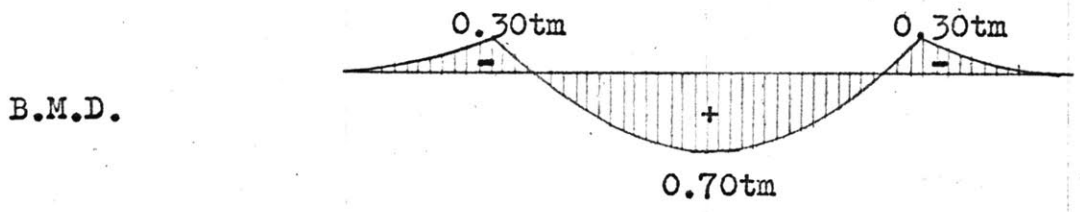

Figure 11

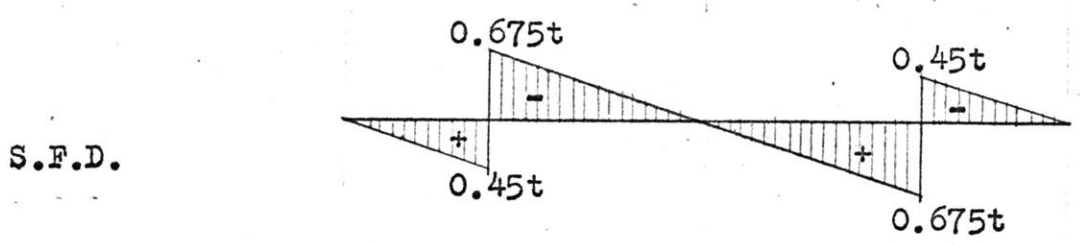

Figure 12

$$d = 0.3 \sqrt{\frac{70000}{25}} = 16 \text{ cms.}$$

t chosen 25 cms

$$A_s = \frac{70000}{1250 \times 22} = 2.55 \text{ cms}^2$$

Chosen 2  $\phi$  1/2" = 2.54 cms<sup>2</sup>

3- Design of three cantilevers supporting beam A:

( Figure 13, page 18 )

$$M_{-ve} = 0.375 \times 2 = 0.75 \text{ tm}$$

$$d = 0.3 \sqrt{\frac{75000}{15}} = 21 \text{ cms}$$

t chosen 25 cms.

$$A_s = \frac{75000}{1250 \times 21} = 2.8 \text{ cms}^2$$

Chosen 2  $\phi$  5/8" = 3.94 cms<sup>2</sup>

4- Design of beam BC: ( figures , page 18 )

$$M_{-ve} = 1.12 \times 2 = 2.25 \text{ tm}$$

$$M_{+ve} = \frac{-6.6 \times 5.5^2}{2} - 1.125 \times 7.5 + 4.45 \times 4.5$$

$$= -9 - 8.5 + 20 = 2.5 \text{ tm.}$$

3- Design of the three cantilevers supporting beam A.

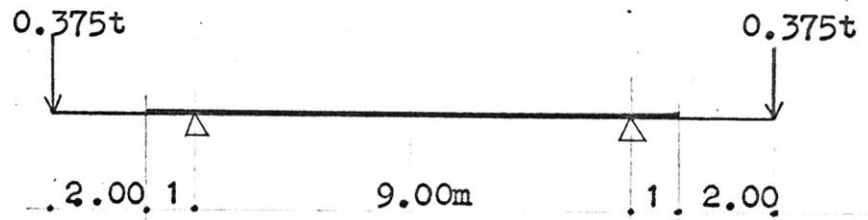

Figure 13

4- Design of beam BC.

L. Distribution

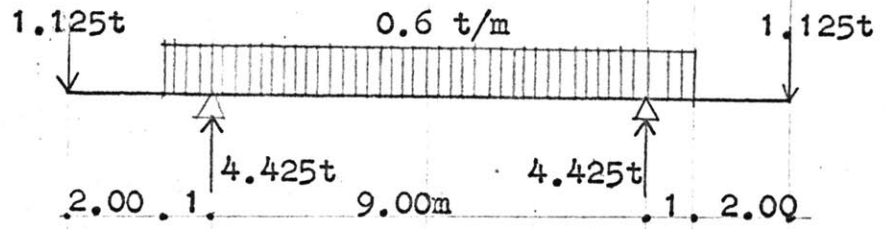

Figure 14

B.M.D.

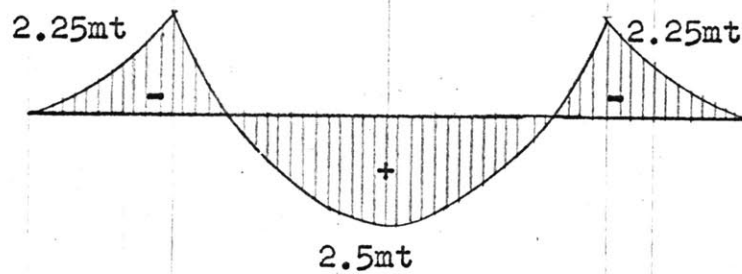

Figure 15

S.F.D.

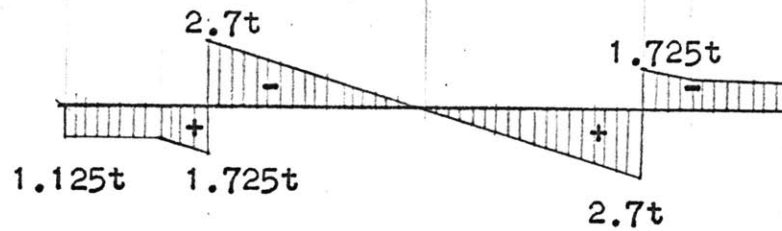

Figure 16

$$d = 0.3 \sqrt{\frac{250000}{180}} = 11.3 \text{ cms}$$

t chosen 25 cms.

$$A_s = \frac{250000}{1250 \times 21} = 9.5 \text{ cms}^2$$

Chosen 8  $\phi$  1/2"

5- Design of pyramidal roof : ( figure 19 page 20 )

$$W_1^i = 0.125 \times \frac{(1.5 + 7.4)}{2} \times \frac{3.35}{7.4} = 0.250 \text{ t}$$

$$W_2^i = \frac{0.25 \times 1.675}{2} = 0.210 \text{ t}$$

$$W_2^i = 2 \times 0.210 = 0.420 \text{ t}$$

$$W_2^h = 5 \times 0.210 = 0.470 \text{ t}$$

$$V_1 = 5 \times 1.11 = 2.475 \text{ t}$$

$$V_h = 2 \times 1.11 = 2.220 \text{ t}$$

$$F_1 = 0.250 + 0.420 + 2.475 = 3.145 \text{ t}$$

$$F_h = 0.470 + 2.220 = 2.690 \text{ t}$$

6- Design of CD, acting as a deep beam to resist  $F_1$ :

( Figure 20, page 20 )

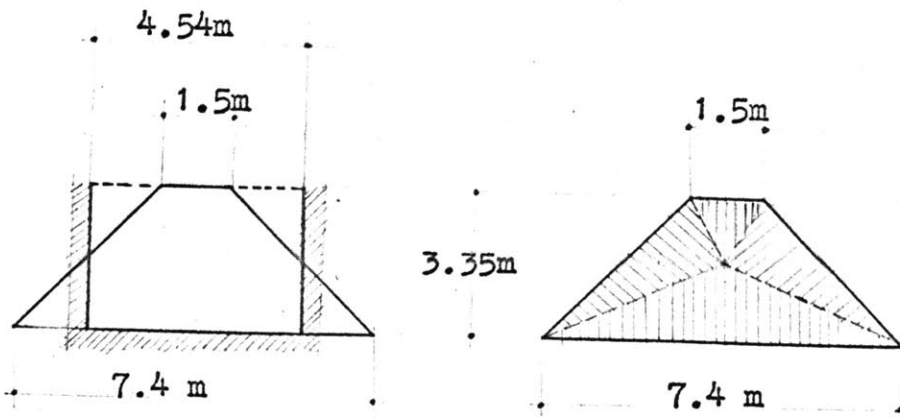

5- & 9- Design of pyramidal roof.

Figure 17

Figure 18

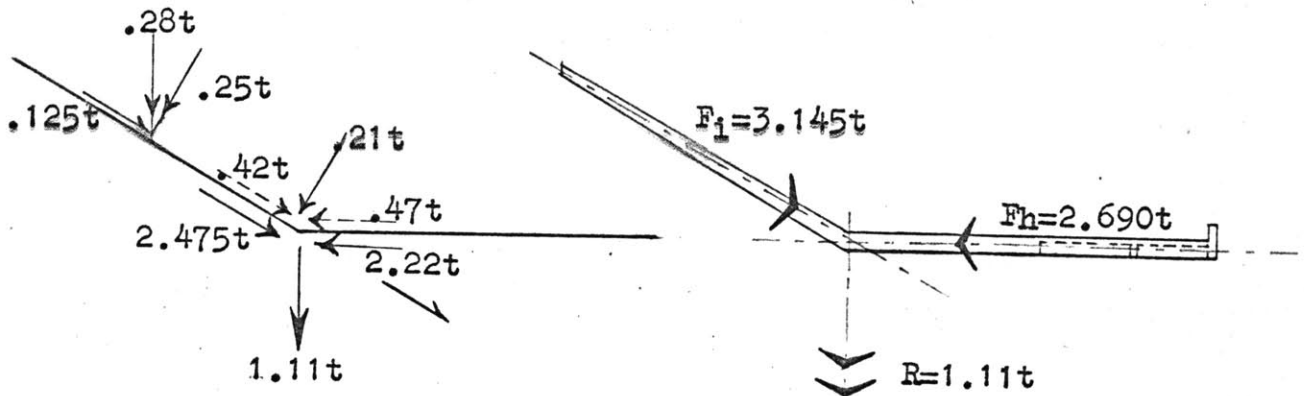

6- Design of CD. Figure 19

Figure 20

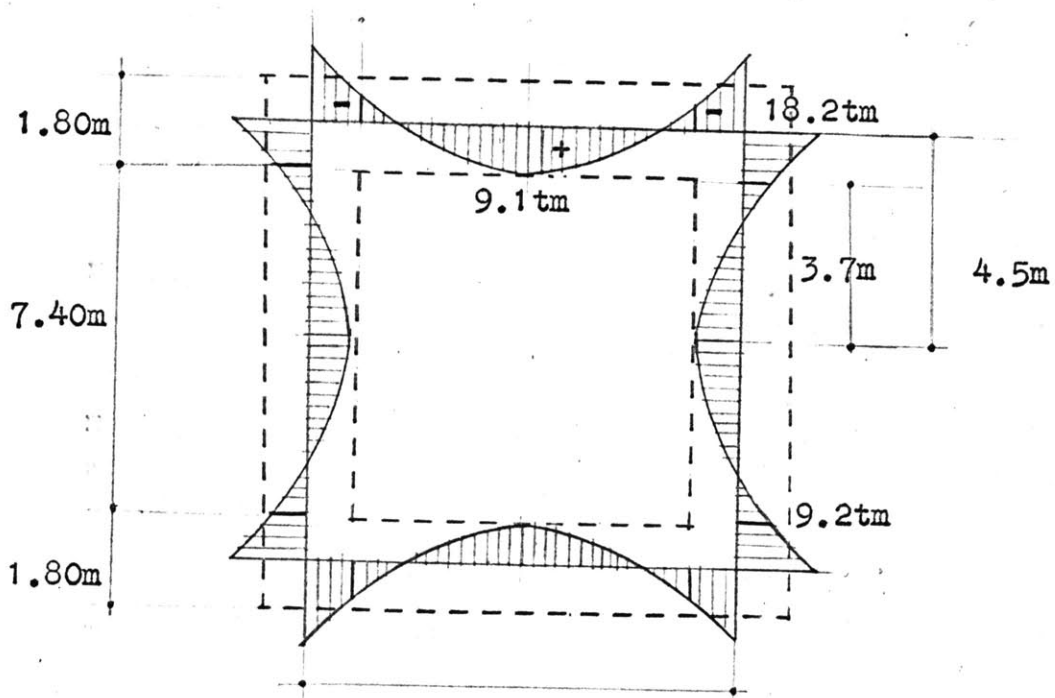

7- Design of tie beam BC.

Figure 21



$$M = 3.145 \times \frac{7.4^2}{8} = 21.5 \text{ tm}$$

$$A_s = \frac{2150000}{1250 \times 0.87 \times 3.35} = 6.6 \text{ cms}^2$$

Chosen 6  $\phi$  1/2" = 7.62 cms<sup>2</sup>

7- Design of tie beam BC : ( Figure 21, page 20)

$$M_{+ve} = \frac{2.690 \times 9^2}{24} = 9.1 \text{ tm}$$

$$M_{-ve} = \frac{2.690 \times 9^2}{12} = 18.2 \text{ tm}$$

$$A_{s+ve} = \frac{910000}{1250 \times 170} = 4.25 \text{ cms}^2$$

To get  $A_{s-ve}$

$$M'_{-ve} = \frac{3.7^2}{4.5} \times 27 - 9.1 = 9.2 \text{ cms}^2$$

$$A_{s-ve} = A_{s+ve} = \frac{920000}{1250 \times 170} = 4.25 \text{ cms}^2$$

Chosen 4  $\phi$  1/2" = 5.08 cms<sup>2</sup>

8- Design of diagonal edges :

$$P = \frac{0.3 \times 7.4^2}{4} = 4.1 \text{ t}$$

Taking one quarter of the load of the pyramidal slab.

$$M_x = M_y = \frac{4.1}{2} \times 0.8 = 1.64 \text{ tm}$$

$$A_s = \frac{164000}{1250 \times 22} = 5.9 \text{ cms}^2$$

$$\text{Chosen } 3 \phi 5/8'' = 5.94 \text{ cms}^2$$

9- Design of pyramidal slab : ( Figure 17 page 20 )

$$A/B = \frac{3.35}{4.45} = 0.75$$

$$M_A \text{-ve} = 0.061 \times 250 \times 3.35^2 = 175 \text{ Kg.m}$$

$$M_B \text{-ve} = 0.036 \times 250 \times 4.45^2 = 180 \text{ Kg.m}$$

$$M_A \text{+ve} = 0.036 \times 250 \times 3.35^2 = 105 \text{ Kg.m}$$

$$M_B \text{+ve} = 0.013 \times 250 \times 4.5^2 = 65 \text{ Kg.m}$$

$$d \text{ for } M_{\max} = 0.38 \sqrt{\frac{18000}{100}} = 5.5 \text{ cms}$$

$$A_s \text{ for } M_{\max} = \frac{18000}{1250 \times 8.5} = 1.8 \text{ cms}^2$$

$$\text{Chosen } 5 \phi 1/4''/\text{m} = 1.6 \text{ cms}^2$$

10- Design of column :

$$\text{Load per column} = \frac{1}{4} (0.3 \times (15^2 - 11^2) + 0.7 \times (11^2 - 7.4^2) + 0.3 \times 7.4^2)$$

$$= \frac{1}{4} \times 93.1 = 23.5 \text{ t}$$

$$P = f_c \times A_c ( 1 + N_x u )$$

$$23500 = 45x A_c(1+15x0.008)$$

$$A_c = \frac{23500}{45} = 425 \text{ cms}^2$$

$$\text{Chosen } 30 \times 30 \text{ cms} = 900 \text{ cms}^2$$

To allow for a drainage pipe of 10 cms ( 4 " ) diameter.

$$A_s = 435x0.004 = 1.74 \text{ cms}^2$$

Chosen 4  $\phi$  3/8 "

11- Design of foundation:

$$\text{Net load on soil} = 24.00 \text{ t}$$

$$f_{\text{all.}} = 0.8 \text{ Kg/ cms}^2$$

i- Design of plane concrete :

$$A = \frac{24.00}{8.0} = 3.00 \text{ m}^2$$

Chosen 180 x 180 x 40 cms depth

ii- Design of reinforced concrete footing :

Dimensions: 100 x 100 x 30 cms depth

$$f = \frac{24}{1.0 \times 1.0} = 24 \text{ tm}$$

$$M = 24 \times 1.0 \times \frac{0.35^2}{2} = 1.5 \text{ tm}$$

$$A_s = \frac{1.5 \times 10^5}{1030 \times 30} = 4.8 \text{ cms}^2$$

$$\text{Chosen } 7 \phi \frac{3}{8} = 4.97 \text{ cms}^2$$

Check of shear

$$Q = 24 \times 1.0 \times 0.35 = 8.4 \text{ t}$$

$$f = \frac{8400}{100 \times 30} = 2.8 \text{ Kg/cms}^2$$

( less than 4.0 )

Check of bond

$$q_{\text{bond}} = \frac{0.85 \times 8400}{30 \times 7 \times 3} = 11.0 \text{ Kg/cms}^2$$

( less than 12.0 )

## 2- QUALITY OF SPACES

The quality of the low horizontal space is different from that of the high one, since they accommodate different activities. The pyramidal high space - of 9 x 9 meters ( 30 x 30 feet ), is designed to house a major group activity, a class room of 30 - 40 students. The introduction of natural top light will allow the continuity of the low , and the high surfaces, a major point affecting the design.

The horizontal low peripheral space - of three meters ( 10 feet ) width - is designed on a one meter ( 3 feet ) grid; this will allow for the subdivision of the space, to house the minor activities, related to the major space, such as circulation, storage, offices, lavatory accommodations.

The low horizontal flat area, combines the pyramidal roof and the grid system, in a harmonious transition of surfaces.

## 3- ADMITTANCE OF LIGHT

Natural light :

Top light : day light is admitted in the structure, through a plastic dome, 1.5 x 1.5 meters ( 5 x 5 feet ), to diffuse the direct sun rays ; below it, is an aluminum grid, to provide uniform intensity of light , over the student's desks.

Side light : will be admitted only from two directions, perpendicular to the plain of the black-board .

Artificial light:

The artificial light is integrated within the structure, and is located in the same place where natural light is admitted, to maintain the same qualities of the space.

The light will fall indirectly, either through the aluminum grid, or reflected from the pyramidal slab, as seen in section. The structure allows the use of 1.2 and 0.6 meter ( 4 feet and 2 feet ) , fluorescent lamps.

Number of lamps needed  

$$K = \frac{h ( l + w )}{2lw}$$

( h, l and w are the dimensions of the room.)  

$$= \frac{10 \times 60}{2 \times 30 \times 30} = \frac{1}{3}$$

f = 0.3348  

$$D = fg \frac{F_1}{A} \quad \text{where } g = 0.60$$

50 = 0.3348 x (0.60)  $\frac{F_1}{200}$

$F_1 = 225,000$  lumens

14 lamps, of 200 watts each, will provide the required intensity, of 50 lumens per foot square, on the student's desks.

#### 4- VENTILATION

The natural flow of air is organized, to ventilate the space. The pyramidal roof will act as a hood, to collect the hot air, full of carbon dioxide, to be sucked out through the ventilating openings, in the uppermost central part. Cold fresh air, is let into the space either , through the side windows, or through controlled louvers at the floor level. This chimney action will speed up the air flow; also a fan could be used to control it, and to eliminate any undesirable thermal conditions, created by the plastic dome. No heating systems are required, on the contrary, heat insulation is needed.

#### 5- ACOUSTICS

No sound treatment is needed, because of the small dimensions of the room. Reverberation time is calculated for the class room, when empty and when full, in both cases, it is between the allowable limits of 0.6 and 1.4 seconds.

$$\text{Reverberation time} = \frac{0.49 V}{a}$$

$$\text{Volume of room} = 11,160 \text{ cubic foot}$$

Surfaces:

$$\text{Brick walls} = 615 \times 0.04 = 24.6$$

Reinforced concrete	= 1264 x 0.3	= 379.2
Glass	= 90 x 0.2	= 18.0
Wood	= 270 x 0.1	= 27.0
Cement floors	= 1170 x 0.02	= 23.4
		472.2
Chairs and tables	= 150 x 0.22	= 33
Chairs, tables and students	= 150 x 0.7	= 105
Class room empty	= 505.2	
Class room full	= 577.2	
Reverberation time when class room is empty		
	= $\frac{0.49 \times 11160}{505.2}$	= 1.08 sec
Reverberation time when class room is full		
	= $\frac{0.49 \times 11160}{577.2}$	= 0.98 sec

Double walls with 15 centimeters ( 6 inches ) , clearance, are used between the lavatory accomodations and the class rooms, to prevent any sound transmission.

## 6- THERMAL INSULATION

Heat insulation will be the main concern, since the weather is generally warm and sunny in Egypt most of the year round, with rain occuring for two to three months during the winter, and only in the northern part of the country.



Light weight aggregate, sand, white cement and gypsum are used in different percentages, according to the climatic conditions; more cement is to be used in wet weather, while more gypsum is to be used in dry weather. Both white cement and gypsum will form good reflecting surfaces, they will increase the amount of reflected light, and will decrease the amount of heat absorbed by the roof. This layer of light-weight concrete, will act as a thermal insulator, that protects the underlying reinforced concrete, from extremes of temperature, thus prevent cracking and leakage of water in cases of rain, also it provides a sloping surface for water drainage.

#### 7- SUBDIVISION OF SPACE

Partitioning : The low peripheral horizontal area, is designed on a one-meter grid. The beams to the interior measure 12.5 centimeters, to receive a 12 centimeter ( 5 inch ), half-brick wall. The beams to the exterior, measure 27 cms, to receive a 25 centimeter ( 10 inch ) one-brick wall, or a 15 centimeter cavity-brick wall.

The one meter module of partitioning , is a reasonable dimension for standard windows, doors, W.C.spacing, etc.

## 8- CONSTRUCTION

### Form work :

Durable materials are selected for the forms, to resist the wear and tear. Forms are to be erected, steel placed in position, concrete poured then left to dry, then the forms are to be dismantled and reused. This will speed the erection cycle, and will cut down the cost.

i- Waffle slab : Metal pans, 1 x 1 meter ( 3 x 3 foot ), 20 centimeters deep ( 8 inches ), are placed on wooden joists, leaving in-between a cavity, to form wedged beams of 12.5 centimeters ( 5 inches ), at the bottom, and 15 centimeters (6 inches ) at the top. This will facilitate pulling out of the metal pans after the setting of the reinforced concrete.

ii- Pyramidal roof : Consists of four half-cylinder surfaces, and four trapezoidal plate, all made of 3 x 3/4 inch hard wood boards, grooved and tongued, leaving a V shaped channel between the boards.

iii- Columns: Forms consist of square wooden shafts, 30 x 30 centimeters ( 12 x 12 inches ) and 240 centimeters ( 8 feet ) in height, with a 4 inch drainage pipe in the center.

iv- Footing : Simple rectangular wooden plated at four sides, and the plane concrete foundation at the bottom,

will form a casing for the footing.

Flooring :

The floor consists of three layers, ( from top to bottom ):

i- 5 centimeter (2 inch ) layer of cement, sand and fine aggregates. A grid pattern , 1 x 1 meter ( 3 x 3 foot ), of grooves is made to prevent the cracking of cement.

ii- 2 centimeter Damp-Proof Course of asphalt.

iii- 15 - 20 centimeter ( 6 - 8 inch ) plane concrete, of cement, sand and aggregates.

CONCLUSION

A Reinforced Concrete structural system, can be developed, to define an architectural expression, of enclosing different spaces for useful occupancy.

The new techniques of construction, and mass production systems, can be utilised to reduce the essential costs, and to facilitate the erection processes.

This study deals with new possibilities, that have broad applications, in the building industry in Egypt.

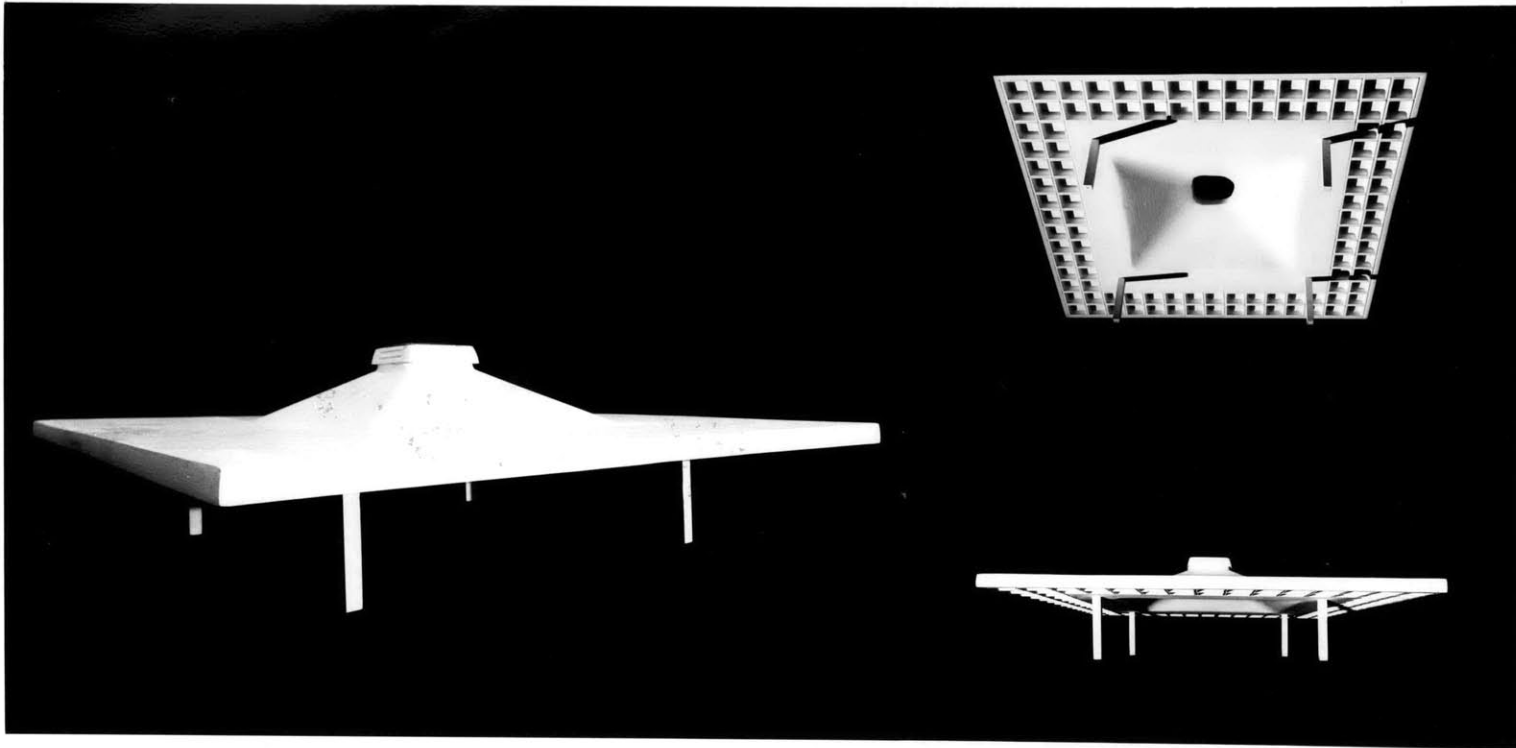

REINFORCED CONCRETE MODULAR ROOF UNIT  
MASTER OF ARCHITECTURE THESIS  
SHAFIK IBRAHIM RIFAAT

JULY 1962

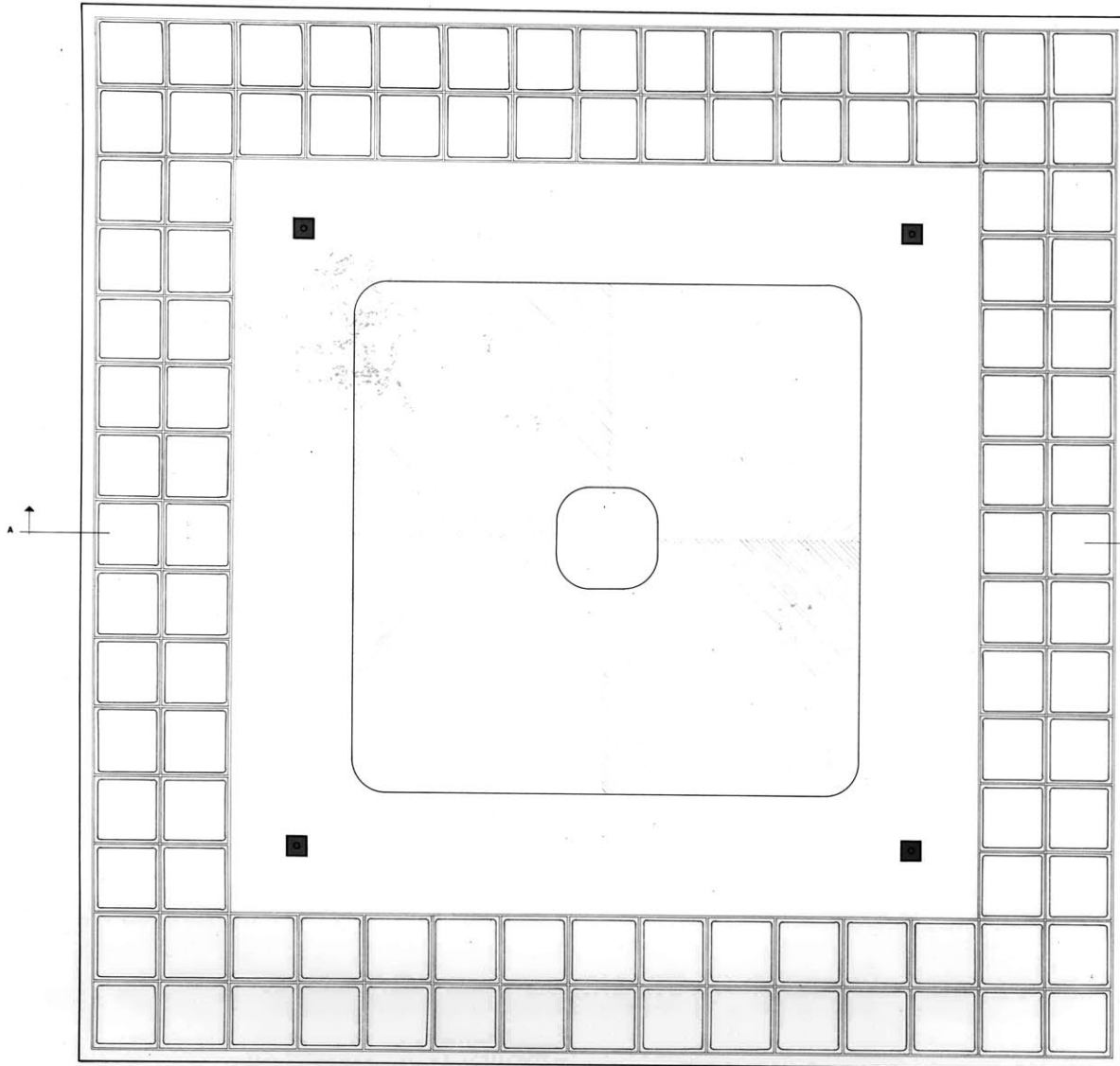

PLAN OF THE UNIT

REINFORCED CONCRETE MODULAR ROOF UNIT  
 MASTER OF ARCHITECTURE THESIS SCALE 1 : 25.  
 SHAFIK IBRAHIM RIFAAT JULY 1962.

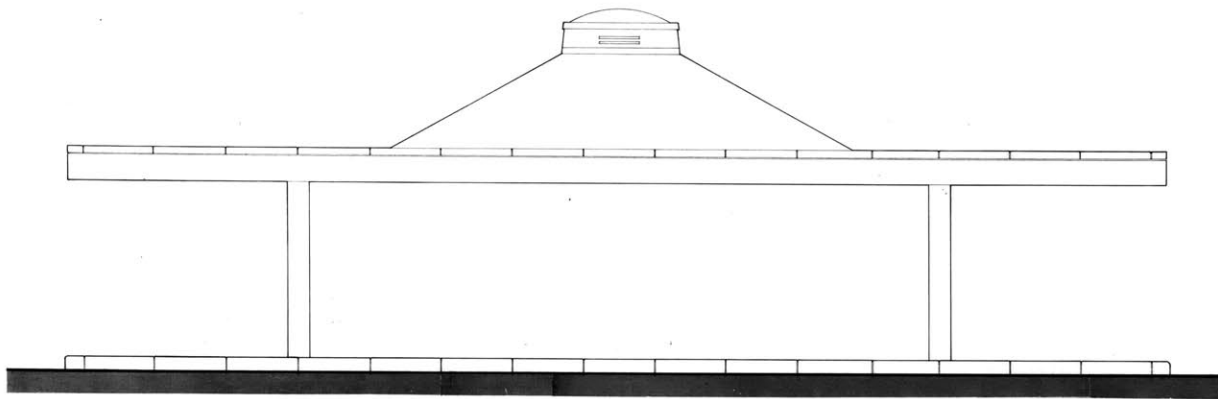

ELEVATION.

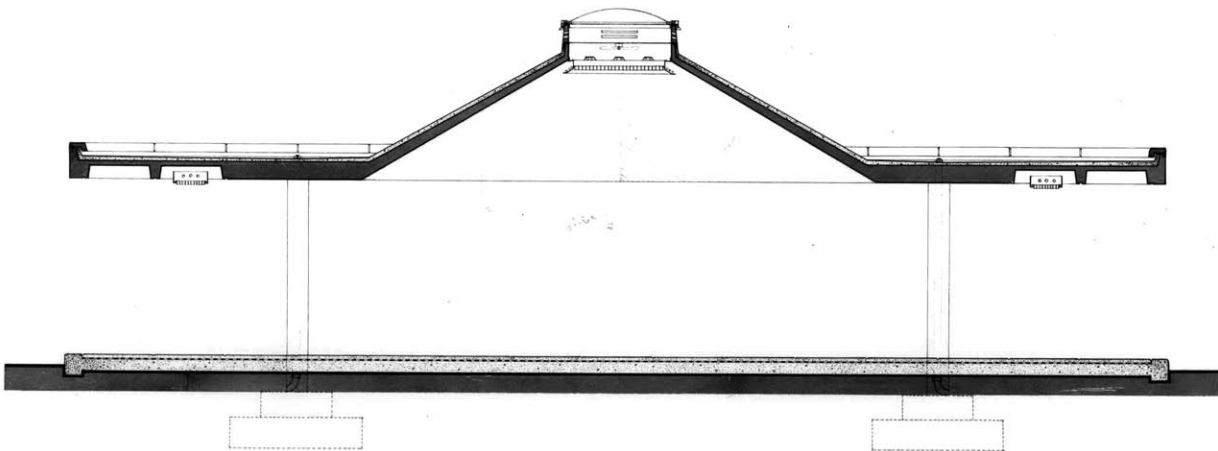

SECTION A-A.

REINFORCED CONCRETE MODULAR ROOF UNIT.  
MASTER OF ARCHITECTURE THESIS SCALE 1:25.  
SHAFIK IBRAHIM RIFAAT JULY 19 62.

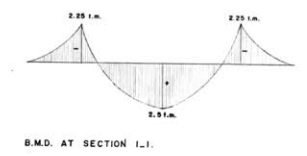
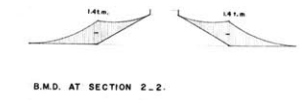
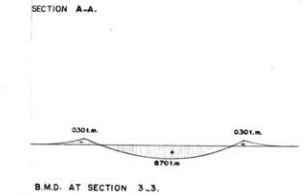
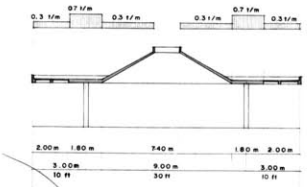
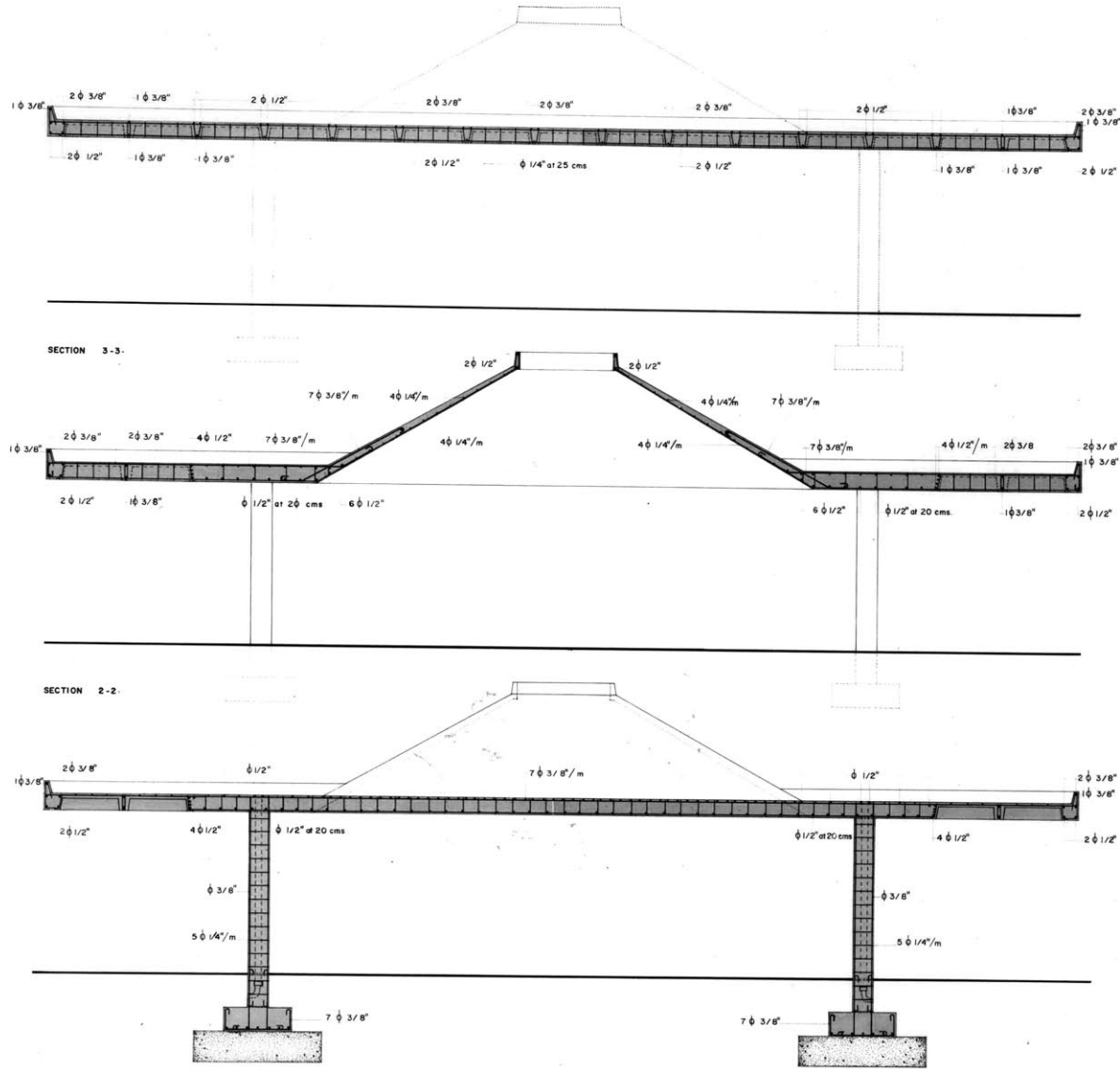

SECTION 1-1.

REINFORCED CONCRETE MODULAR ROOF UNIT  
 MASTER OF ARCHITECTURE THESIS  
 SHAFIK IBRAHIM RIFAAT  
 SCALE 1 : 25  
 JULY 1962

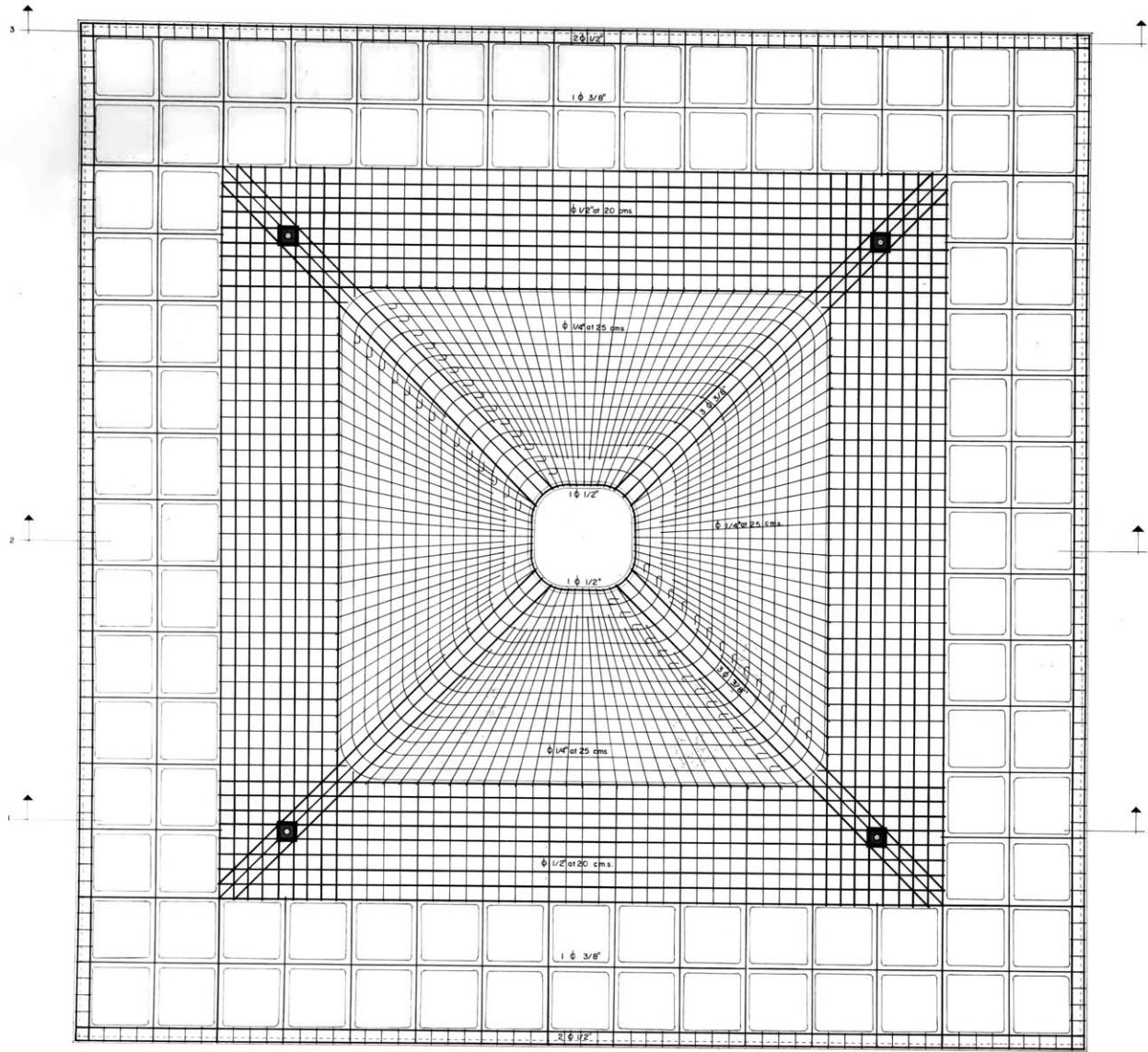

PLAN OF CEILING

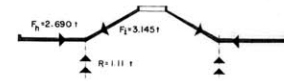

FOLDED PLATE ACTION TO RESIST FORCE R.

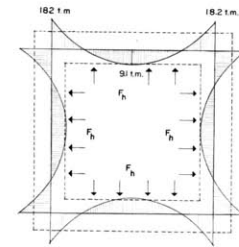

TIE BEAM ACTION TO RESIST HORIZONTAL FORCE  $F_h$ .

REINFORCED CONCRETE MODULAR ROOF UNIT  
 MASTER OF ARCHITECTURE THESIS SCALE 1 : 25  
 SHAFIK IBRAHIM RIFAAT JULY 1962



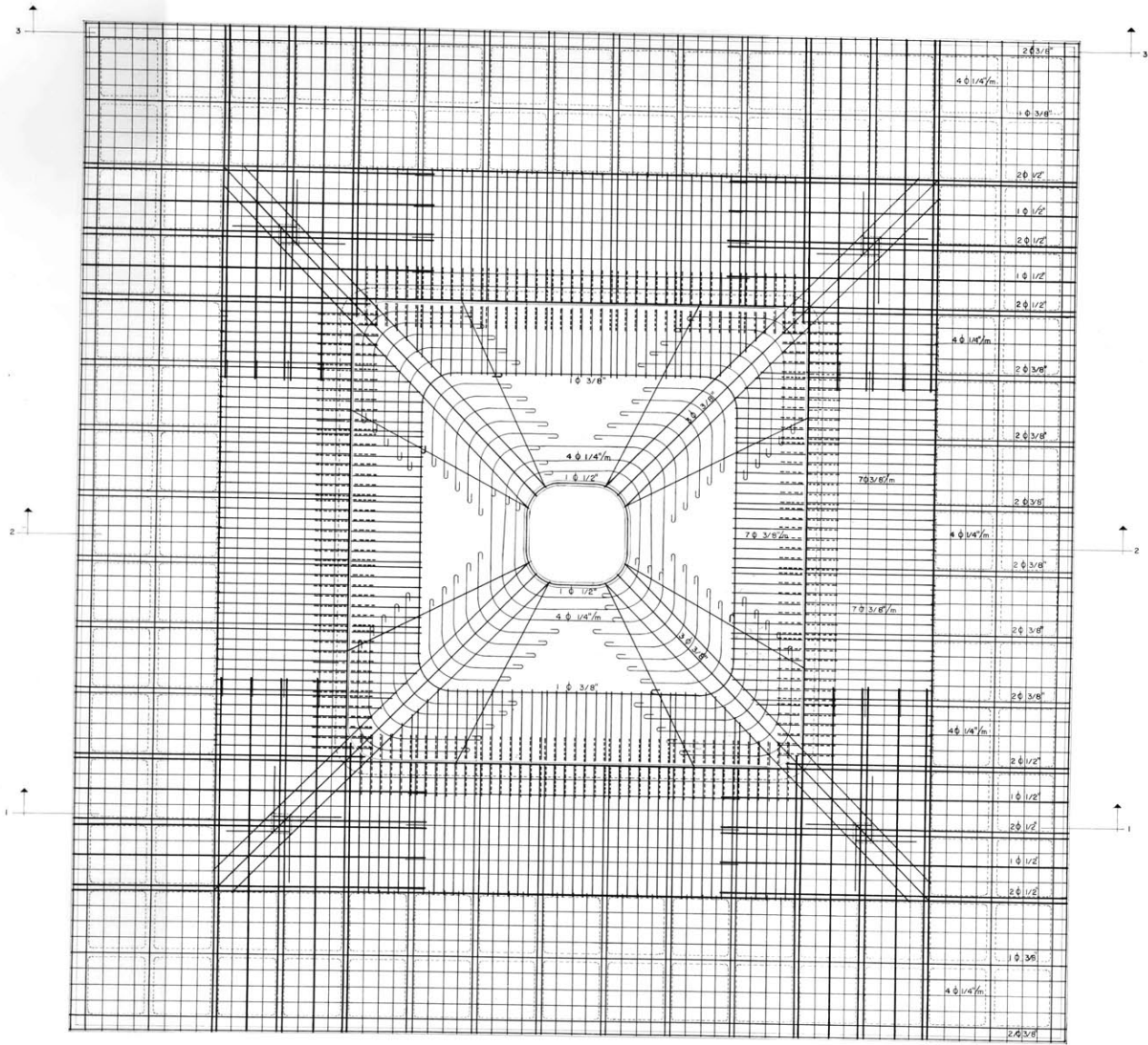

PLAN OF ROOF

REINFORCED CONCRETE MODULAR ROOF UNIT  
 MASTER OF ARCHITECTURE THESIS  
 SHAFIK IBRAHIM RIFAAT  
 SCALE 1 : 25  
 JULY 1962

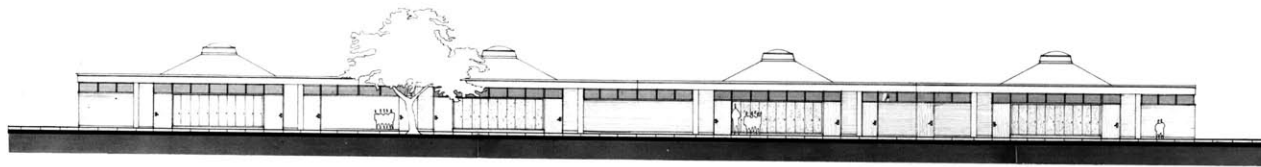

ELEVATION

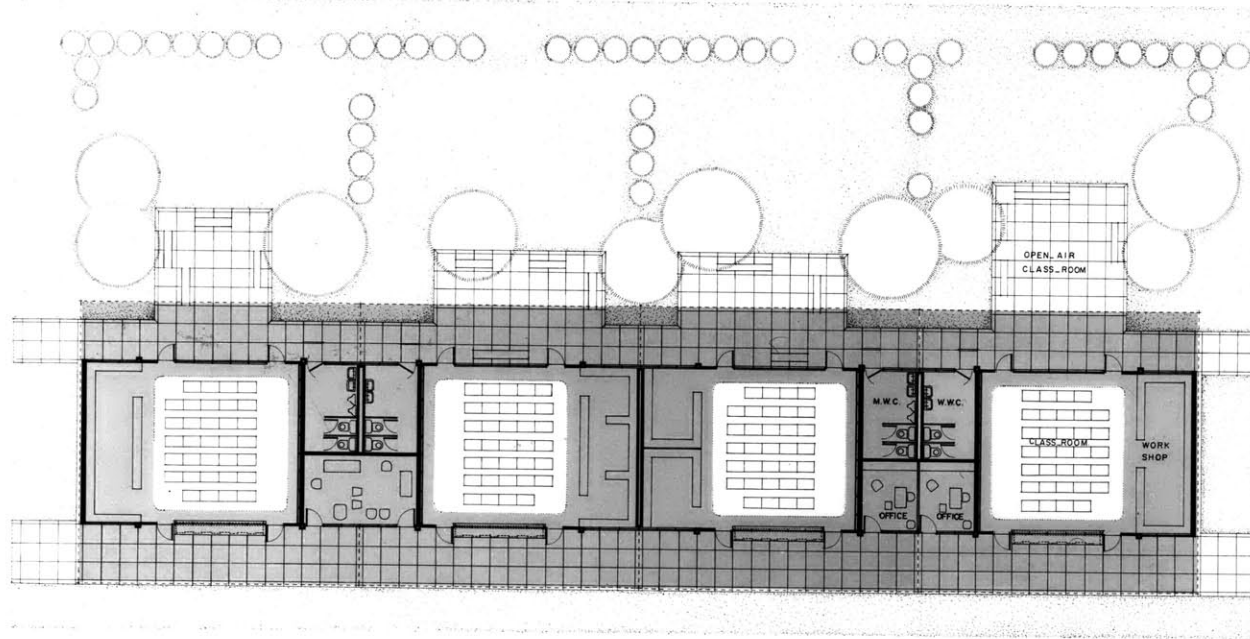

PLAN

REINFORCED CONCRETE MODULAR ROOF UNIT  
 MASTER OF ARCHITECTURE THESIS SCALE 1:25  
 SHAFIK IBRAHIM RIFAAT JULY 1962

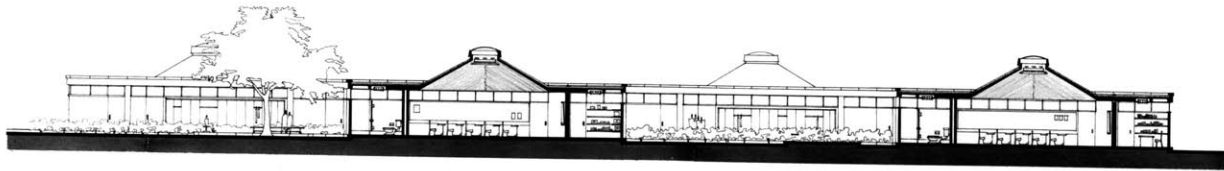

SECTION A-A.

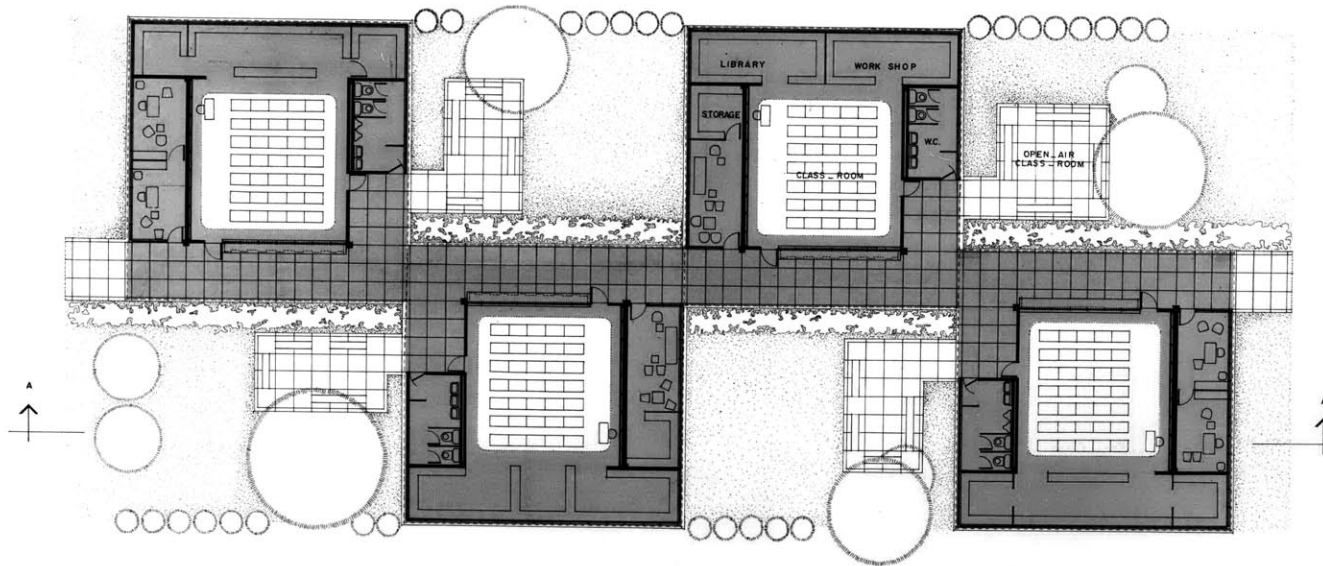

PLAN

REINFORCED CONCRETE MODULAR ROOF UNIT  
 MASTER OF ARCHITECTURE THESIS SCALE 1 : 25  
 SHAFIK IBRAHIM RIFAAT JULY 1962

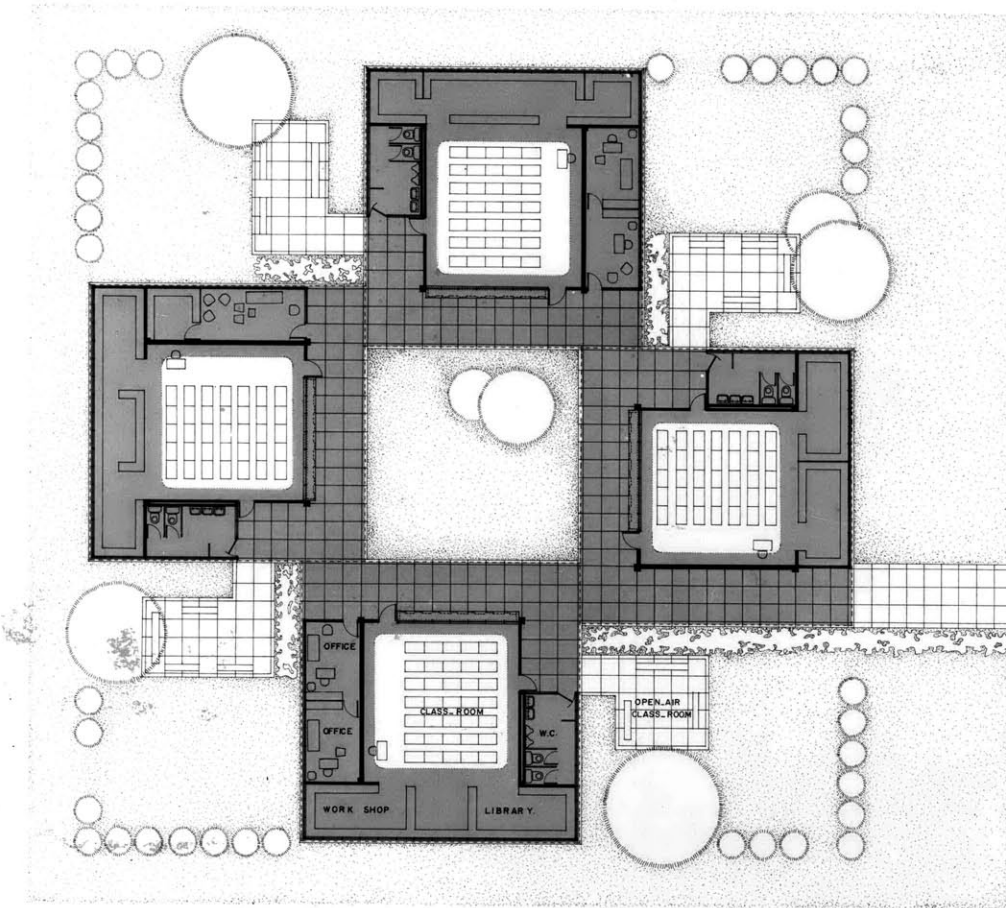

PLAN

REINFORCED CONCRETE MODULAR ROOF UNIT.  
MASTER OF ARCHITECTURE THESIS. SCALE 1 : 25.  
SHAFIK IBRAHIM RIFAAT. JULY 1962.