

INVESTIGATION ON THE RANGE OF APPLICABILITY OF
CONVENTIONAL CONSTRUCTION TECHNOLOGY TO A SPECIAL DESIGN

by

SUZANNE STEWART

B.F.A. Rhode Island School of Design
1971

Submitted in Partial Fulfillment
of the requirements for the
Degree of

Master of Architecture
at the
Massachusetts Institute of Technology
September 1980

© Suzanne Stewart 1980

The author hereby grants to M.I.T. permission to reproduce and distribute publicly
copies of this thesis document in whole or in part.

Signature of Author.....
Department of Architecture
May 21, 1980

Certified by.....
Waclaw Zalewski, Professor of Structures
Thesis Supervisor

Accepted by.....
Professor Maurice K. Smith, Chairman
Departmental Committee for Graduate Students 1

Rotch
MASSACHUSETTS INSTITUTE
OF TECHNOLOGY

SEP 25 1980

LIBRARIES



Room 14-0551
77 Massachusetts Avenue
Cambridge, MA 02139
Ph: 617.253.2800
Email: docs@mit.edu
<http://libraries.mit.edu/docs>

DISCLAIMER OF QUALITY

Due to the condition of the original material, there are unavoidable flaws in this reproduction. We have made every effort possible to provide you with the best copy available. If you are dissatisfied with this product and find it unusable, please contact Document Services as soon as possible.

Thank you.

The images contained in this document are of the best quality available.

Special Thanks
to
Waclaw Zalewski, advisor
Ed Allen, reader
Barry Zevin, reader

Investigation on the Range of Applicability
of Conventional Construction Technology to a
Special Design

by

Suzanne Stewart

Submitted to the Department of Architecture on May 21, 1980, in partial fulfillment of the requirements for the degree of Master of Architecture.

ABSTRACT

This thesis explored the architectural possibilities of a three dimensional steel truss, concrete double Tees, and the industrialized construction of a shell form. All of these systems seem unlikely coverings for the free form plan of the building. The goal was to use standard parts available from the construction industry to create unusual forms. All the above systems proved to be very stiff. Pushing the various systems to their architectural limits demonstrated the qualities possible within each system.

Thesis Supervisor: Waclaw Piotr Zalewski
Title: Professor of Structures

The purpose of this thesis is to explore the architectural possibilities of industrialized building systems. Three long span two-way systems were investigated individually. Each system was made to respond to the same floor plan and intended functional characteristics of the building in order to compare the character or personality of each system. The three systems are: a three-dimensional (3-D) steel truss, a concrete double Tee and a shell or surface structure.

THE BUILDING PLAN

I chose to explore the roofing possibilities of a building design that had evolved from a previous design studio. Because one major edge of the site is a barren parking lot, the streetscape at this intersection is very weak and needs a strong building edge for the street contour. Therefore, the building was pushed as far as possible into the odd corner of the lot. The particular part

of the building that is the basis of the study is a mixture of many convergent angles. It presents the greatest challenge to an orthogonal building system testing the limits of a system's architectural or formal capabilities.

THE BUILDING CHARACTER

The building is a public gateway to the park which sits beyond it. The building protects the park from a busy city street, announces its presence to passersby, and its character invites the public to enter. It is not just another city building; it is the park building, "the gazebo" pushed to the front. The roof expresses this park atmosphere to the street. Because the building is also part of the cityscape and is a public enterprise, it doesn't want to be small and intimate on the street side. Instead, it wants to say "everyone belongs here." A grand public scale that retains an everyday comfortableness - something akin

4 INTRODUCTION

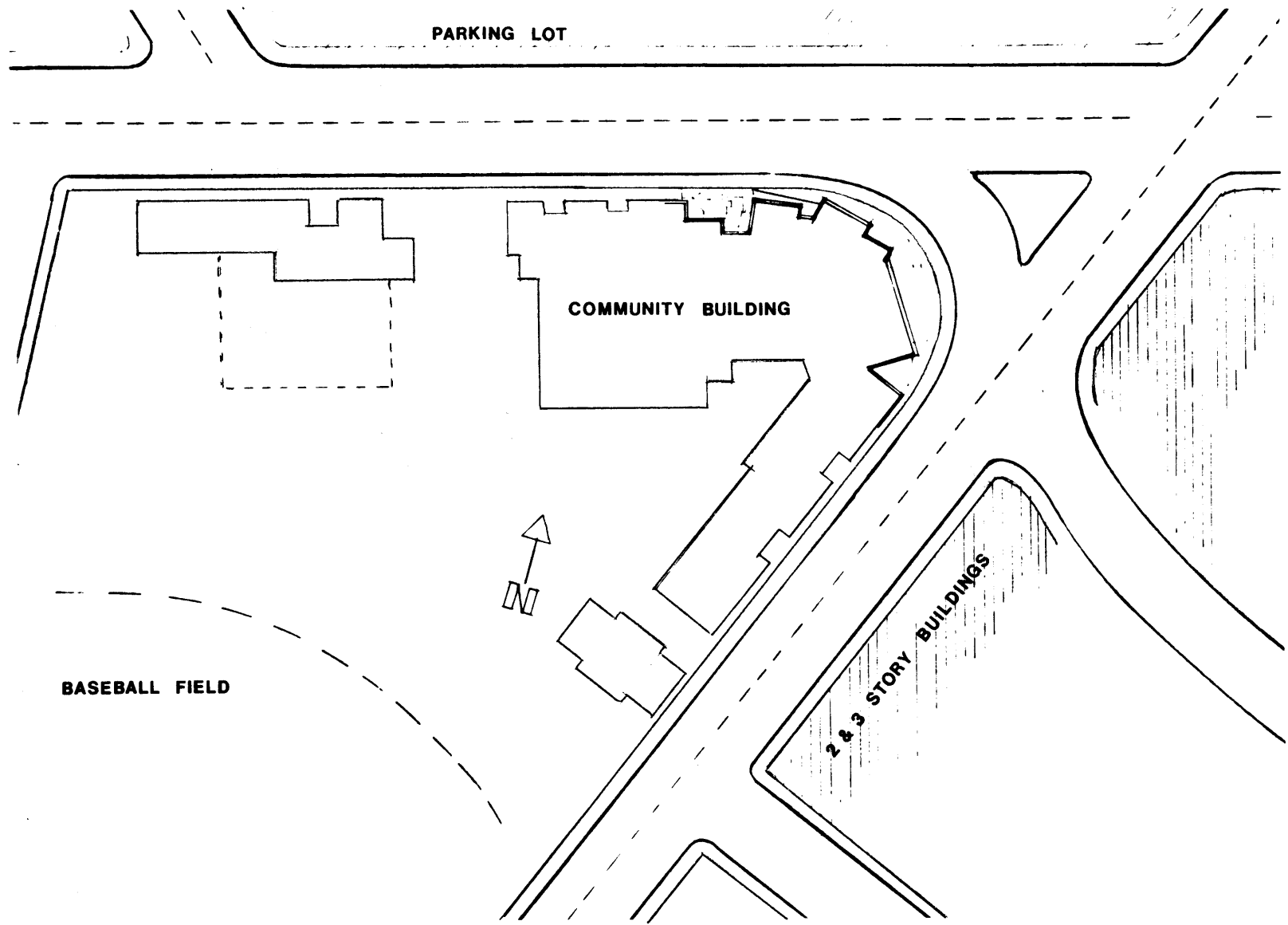

site plan

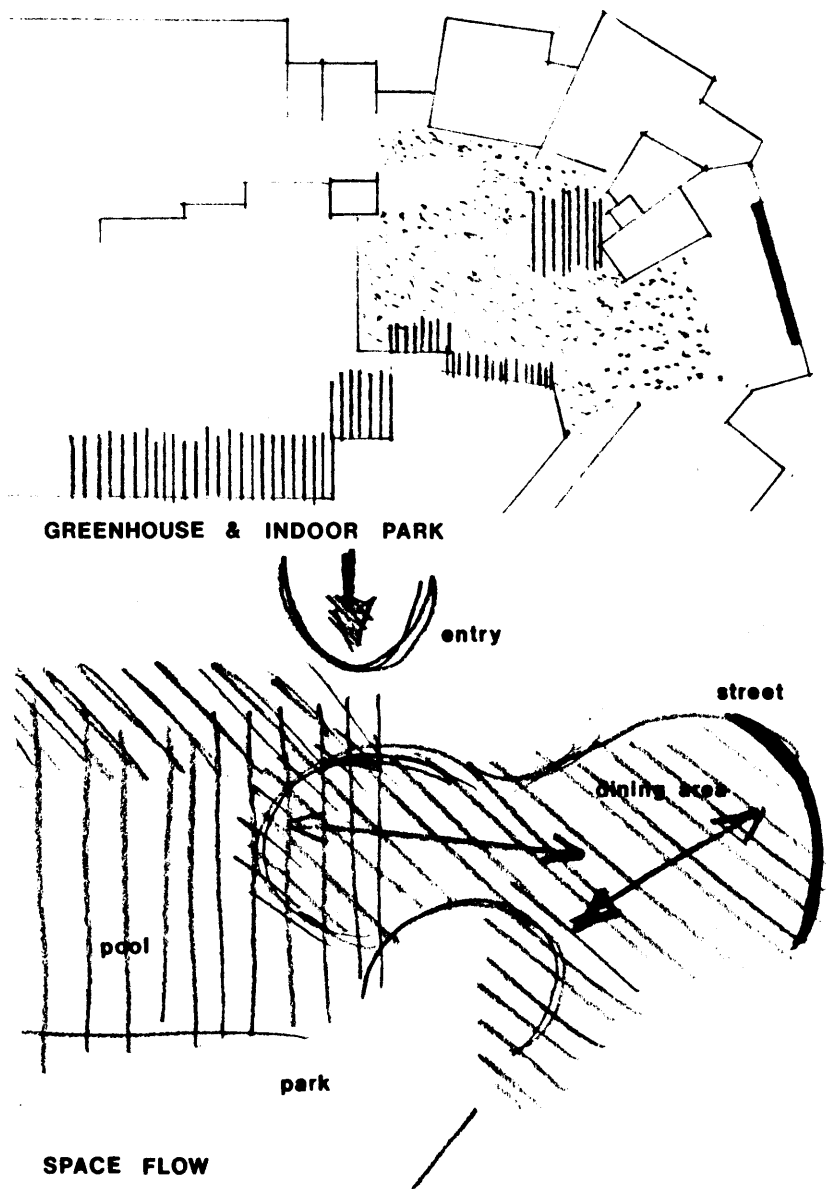

to a post office - belongs here.

THE BUILDING PROGRAM

This is a community building. It combines a medical clinic with athletic facilities and communities services. The emphasis is on health. The pool and the park beyond are the centers of attraction. The waiting rooms of the three floor clinic all face onto the pool. The central public space of the building revolves to give a multitude of views of the park and the pool. This central space and the pool will function as greenhouses and with their south-facing windows will become an indoor park during winter.

The dining room is an extension of central public space and is the elders' lunch room. The dining room floor steps down towards the pool casually extending the eating area into a more public space. Alternatively these steps function as an ascending seating area of a small theatre.

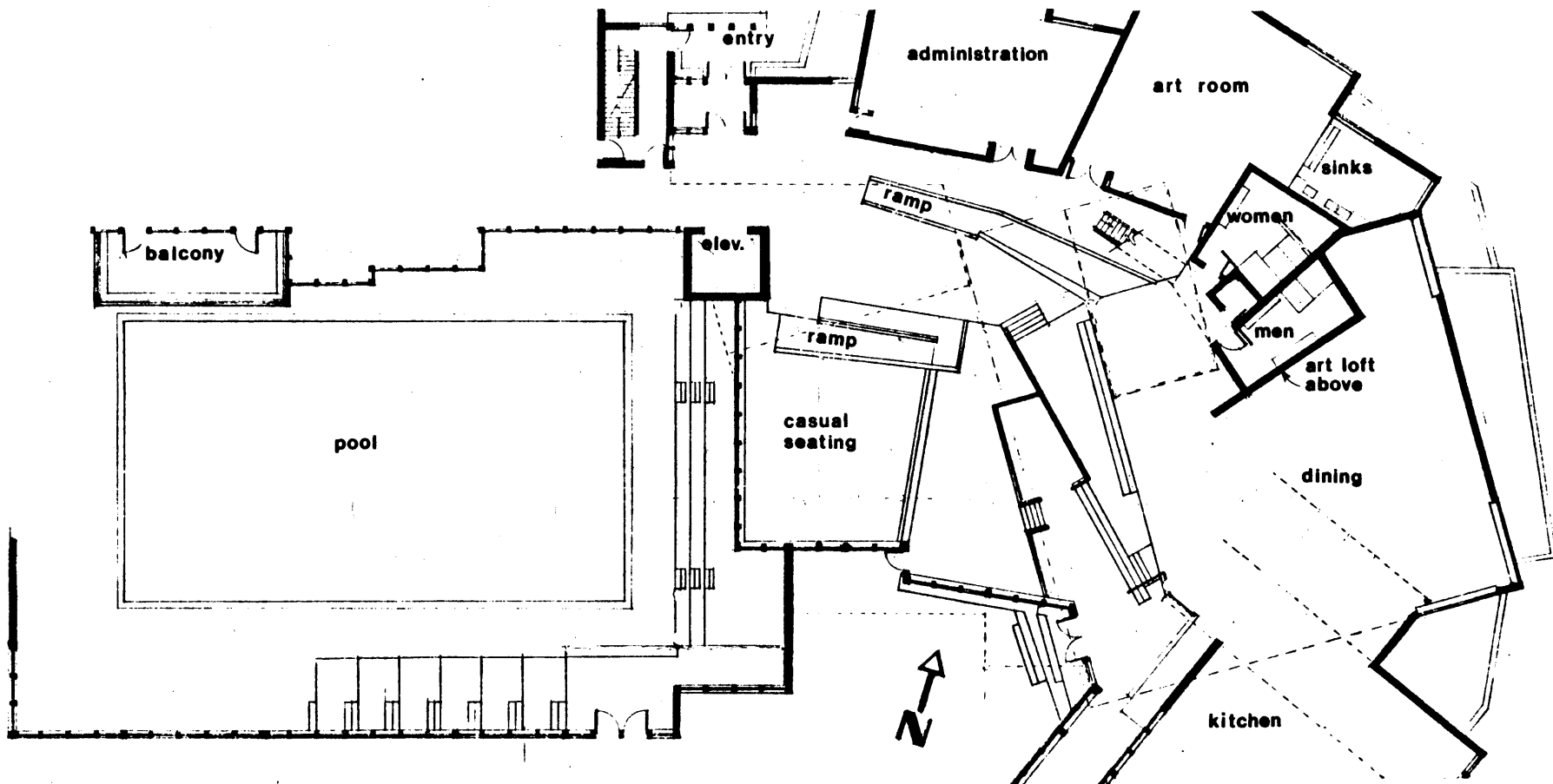

(The daily ongoing performers are the swimmers in the pool.)

Extending from the dining room is a wing containing the kitchen and other separate rooms for community services. Just outside the art room is a stair

which leads to an artist's loft over the restrooms. The loft, a balcony area overlooking the public space, imparts added flexibility to the art room and allows access to southern light and the roof.

plan

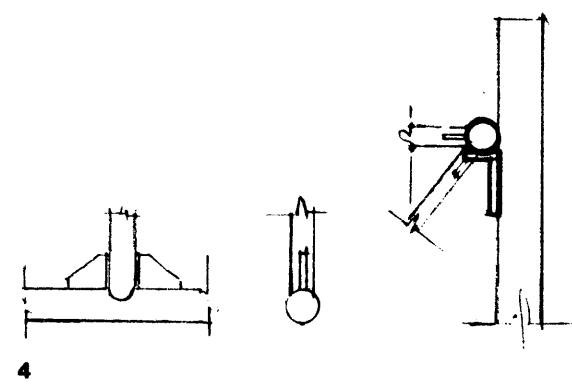
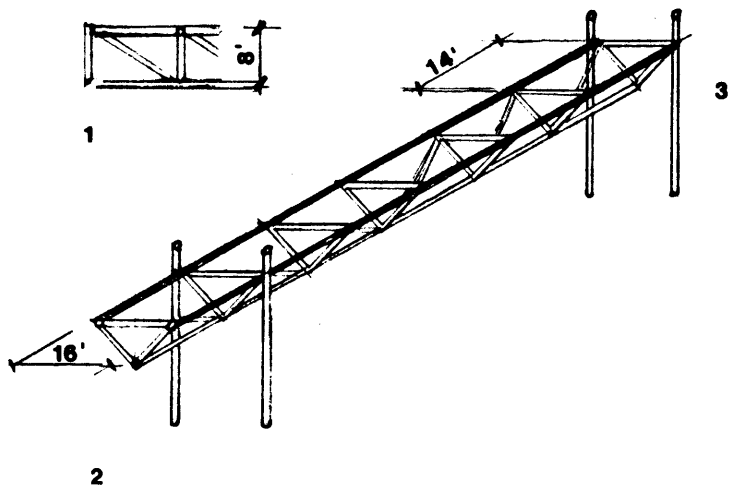

THE SPANNING ELEMENT

Physical Components:

economic spanning range - 50 feet to 150 feet

steel pipe structure with welded connections

depth - 8' (1), width - center to center with columns is 16' (2)

cantilever - 14', one bay (3)

supported by steel columns, welded connections (4)

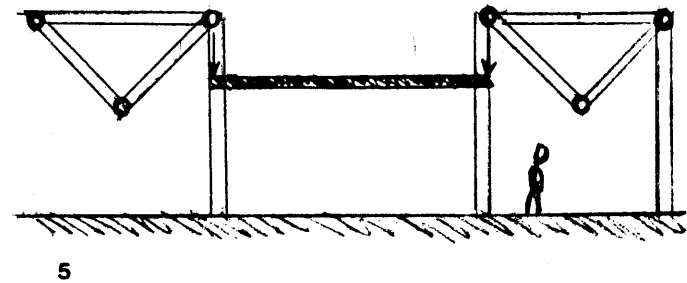

top two chords support load (A secondary system can be hung between two trusses supported by these chords.) (5)

8 THREE DIMENSIONAL TRUSS

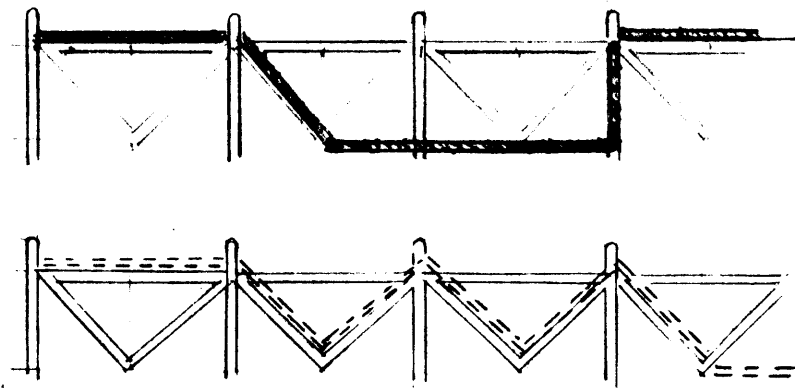

6

roof enclosure - insulated steel decking or glass (The enclosure can follow straight line across top chords or can follow diagonals.) (6)

Character:

light, airy, skeletal

large enough for a person to stand

in (7)

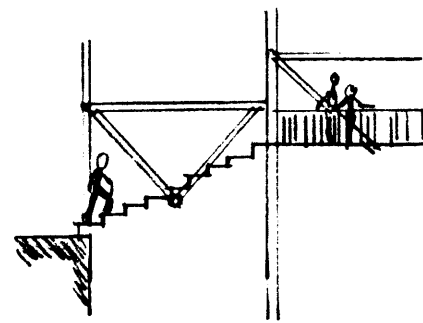

7

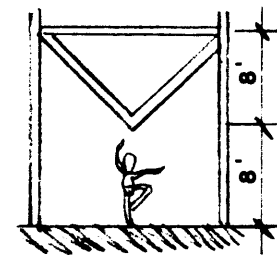

8

3-dimensional, spatial depth
scale of truss dictates that its
lower chord not be placed lower
than 8' ceiling height to avoid
being oppressive to those people
standing below it (8).

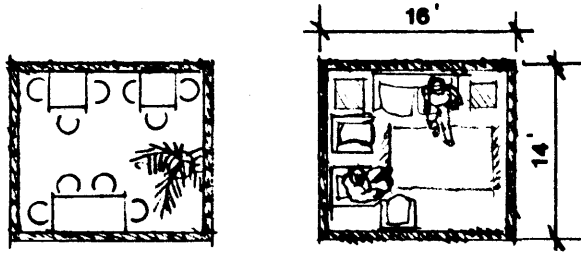

9

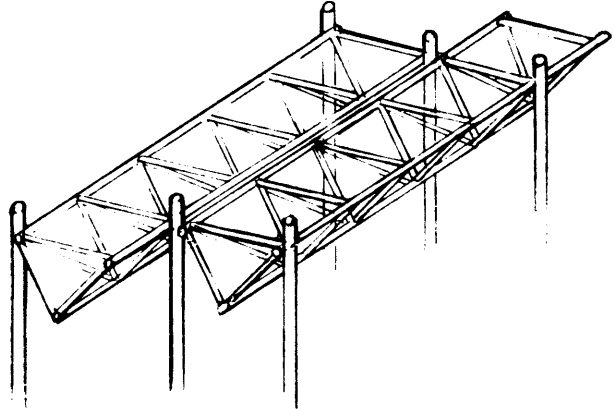

10

one 14' x 16' bay equals the size of a living room or dining area for several tables (9)

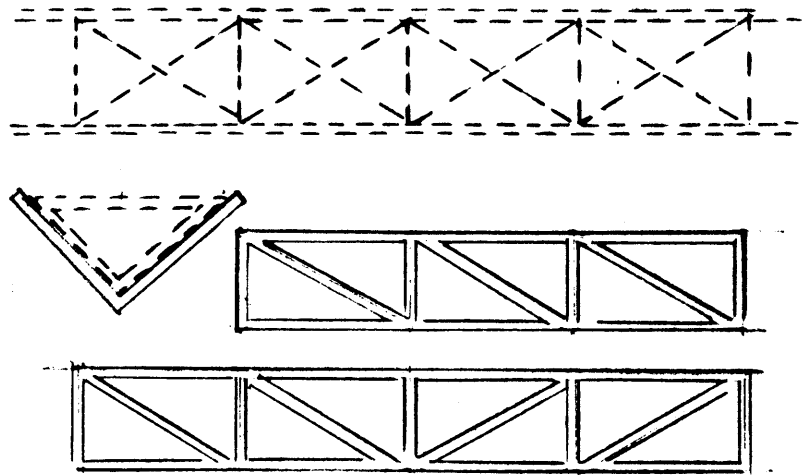

11



Industrialization:

Each truss is designed individually to meet its different loading conditions. (10) However, the trusses will all appear to have the same size members because the tubes are beefed up on the inside. Thus, a template can be used for assembling the trusses quickly in the factory. Longer or shorter trusses can be produced from this. (11)

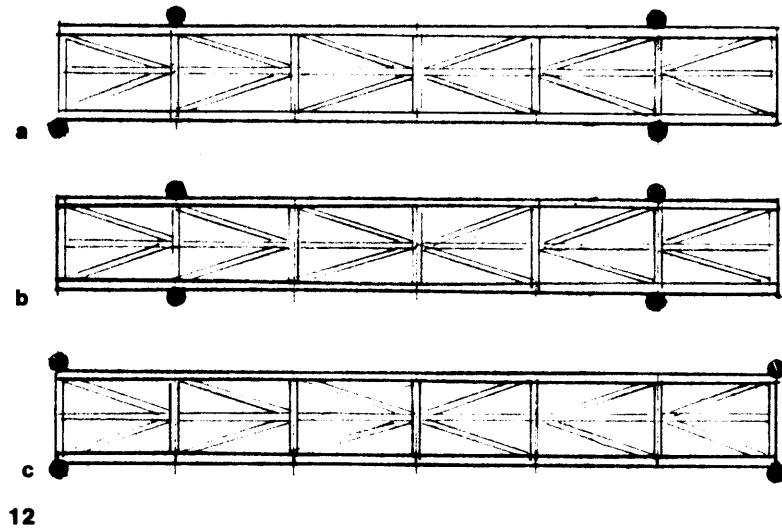

THE SUPPORTING COLUMNS

The columns must be placed at 14 ft. intervals. They can be placed at the end of the truss (12a), with a cantilever at each end (12b), or with an uneven cantilever (12c). This allows lateral displacement of adjoining trusses.

In plan, the columns can create spaces or zones or can emphasize directional changes in the flow of space (13).

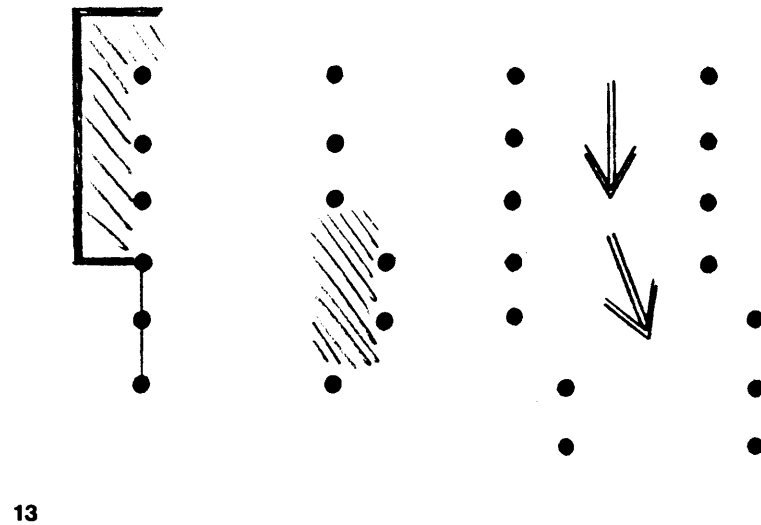

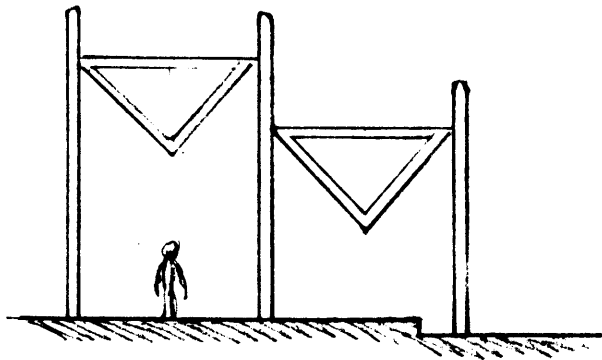

14

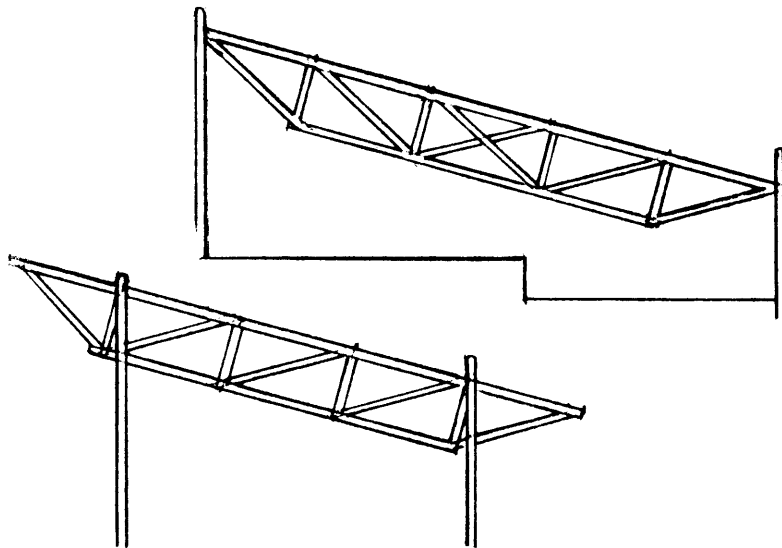

15

The trusses can be placed at any height along the column. The roof can step vertically allowing clerestories for light penetration or creating "room" size spaces for use on the roof top during good weather (14). The trusses can also slant for a sloped roof (15).

INFILL SYSTEM

Open web joists have been used as the roofing system for the series of rooms strung like beads on the exterior of the building. The skylight, like a newel post of a stairway, is the focal point around which the beads move (16). Part of one 3-D truss forms the skylight.

Open web joists will also be used as the infill system (dotted area on plan (16)). The exposed joists will continue the light, airy, skeletal quality of the 3-D trusses. A contrast will exist in scale (size of joists vs. size of trusses) and in density (number of joists per area vs. number of trusses per area).

The balcony emphasizes movement around another "newel post," the elevator (17). The lower roof of infill parallels the orthogonal direction of the pool (18).

3-D truss, infill system

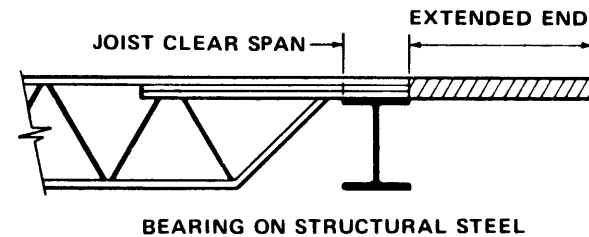
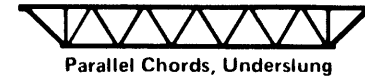

19

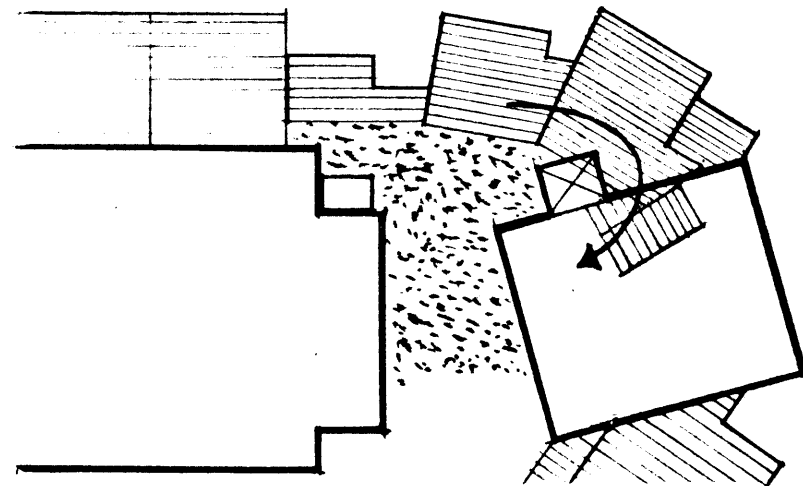

16

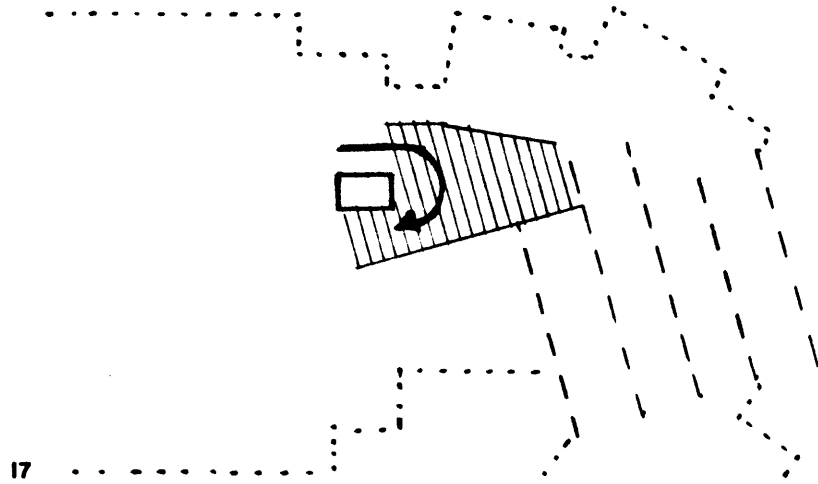

17

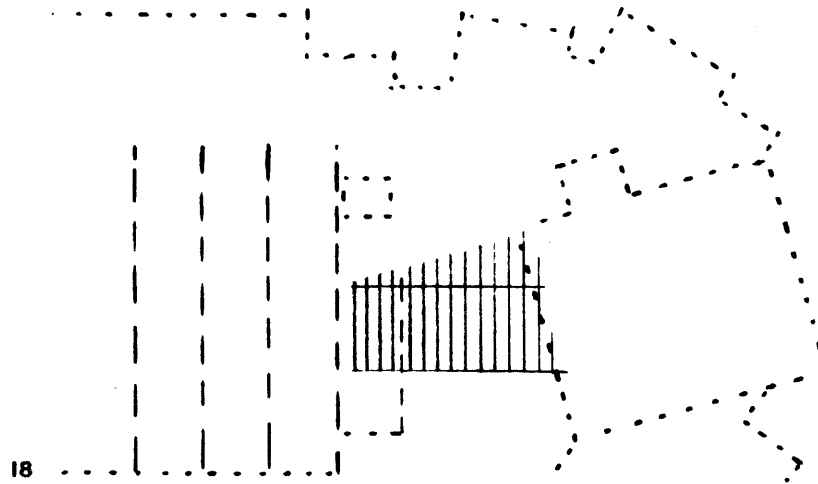

18

The joists must end at the column line because the open web joists have little cantilever capability (19). It is difficult to indicate with these structural elements an overlap of space flows from two different directions. Thus, the two directions come together abruptly. To soften this the balcony floats between its two outer walls allowing a flow of space up to the clere-story from the room below.

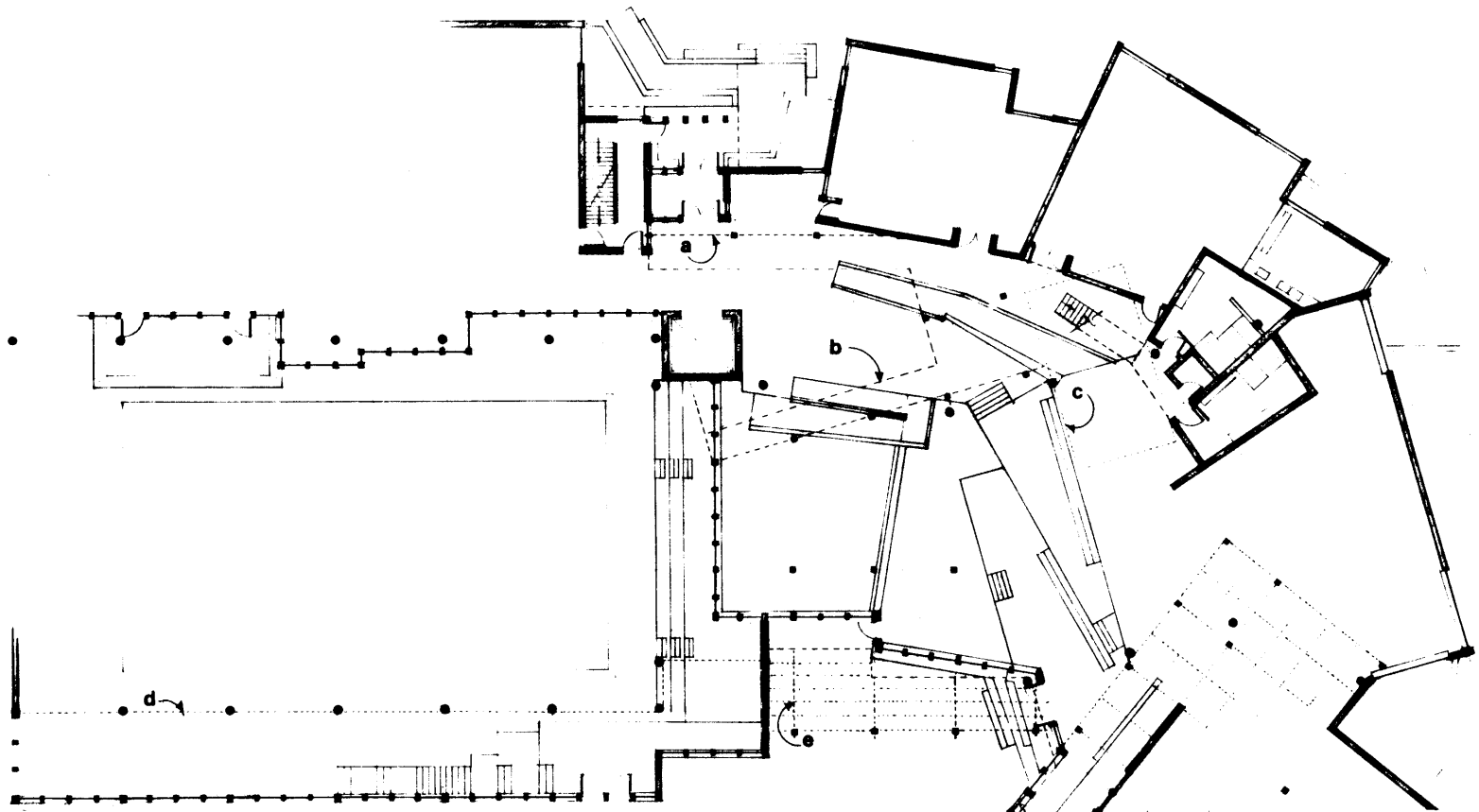

- (a) line of clerestory at upper level giving light to space below
- (b) balcony at second story level (It comes from clinic, turns around elevator and looks out over pool.)
- (c) skylight over stair to art loft
- (d) column line follows inside edge of

glass-roofed greenhouse (Insulated garage-type doors are hung between the columns closing off the glassed area at night to prevent heat loss in pool area.)

- (e) exposed trusses support lattice shading device outside

plan

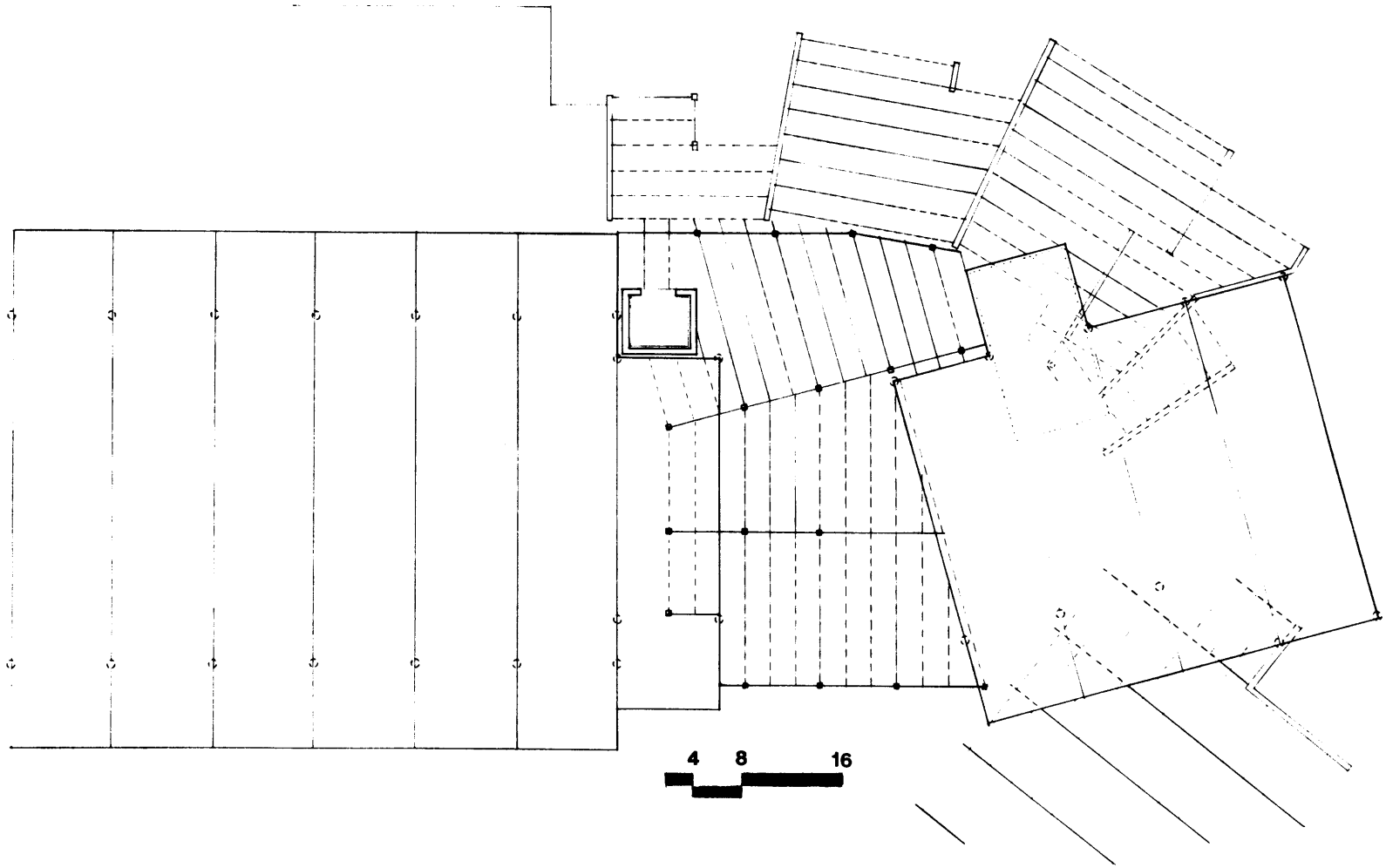

16 structural roof plan

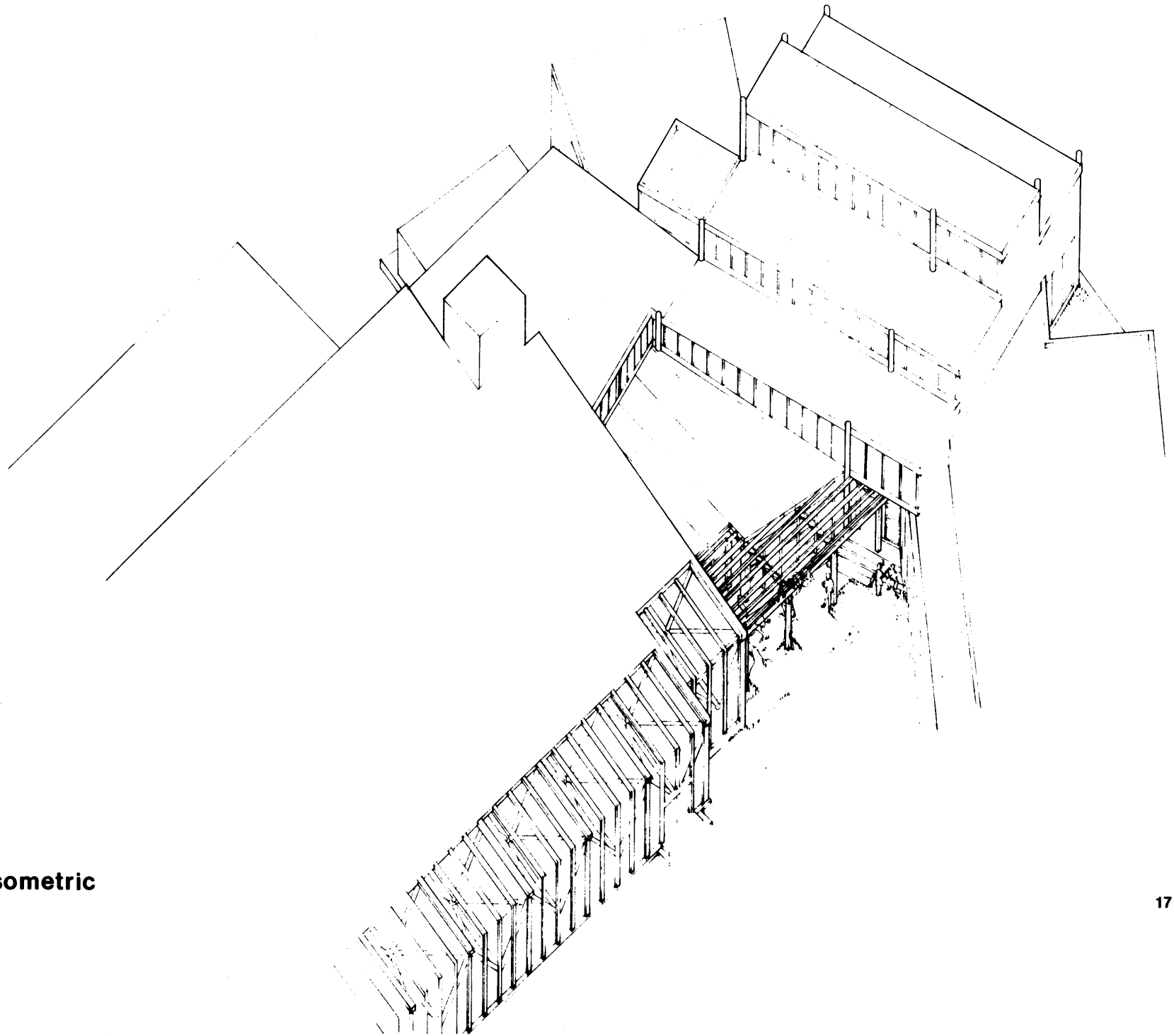

isometric

CONCLUSION

Because the 3-D truss is so orthogonal it seemed that the infill system must also be orthogonal in order to be effective visually. A free flowing cast-in-place concrete roof could perhaps resolve all the direction changes easily. However, I could not envision it standing juxtaposed to the rigid trusses without the two systems detracting from one another.

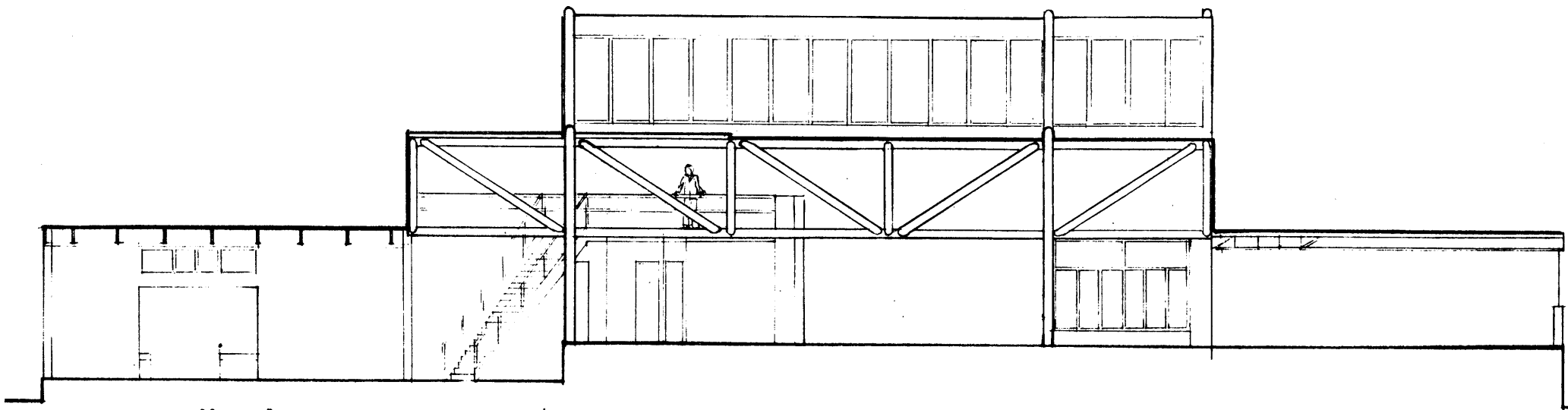

section A

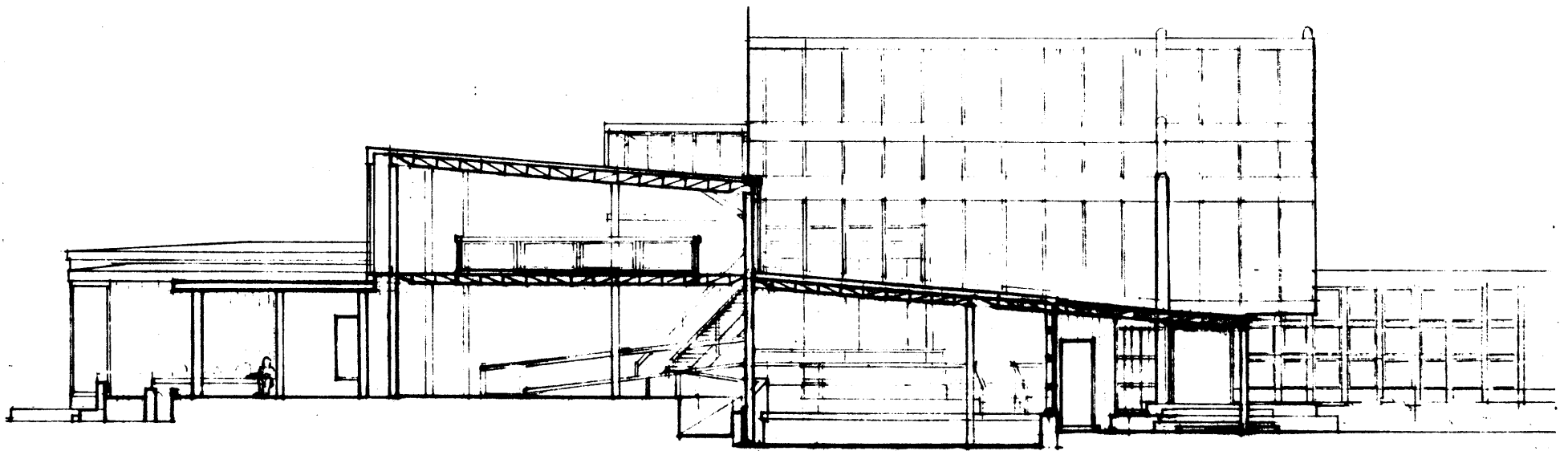

section B

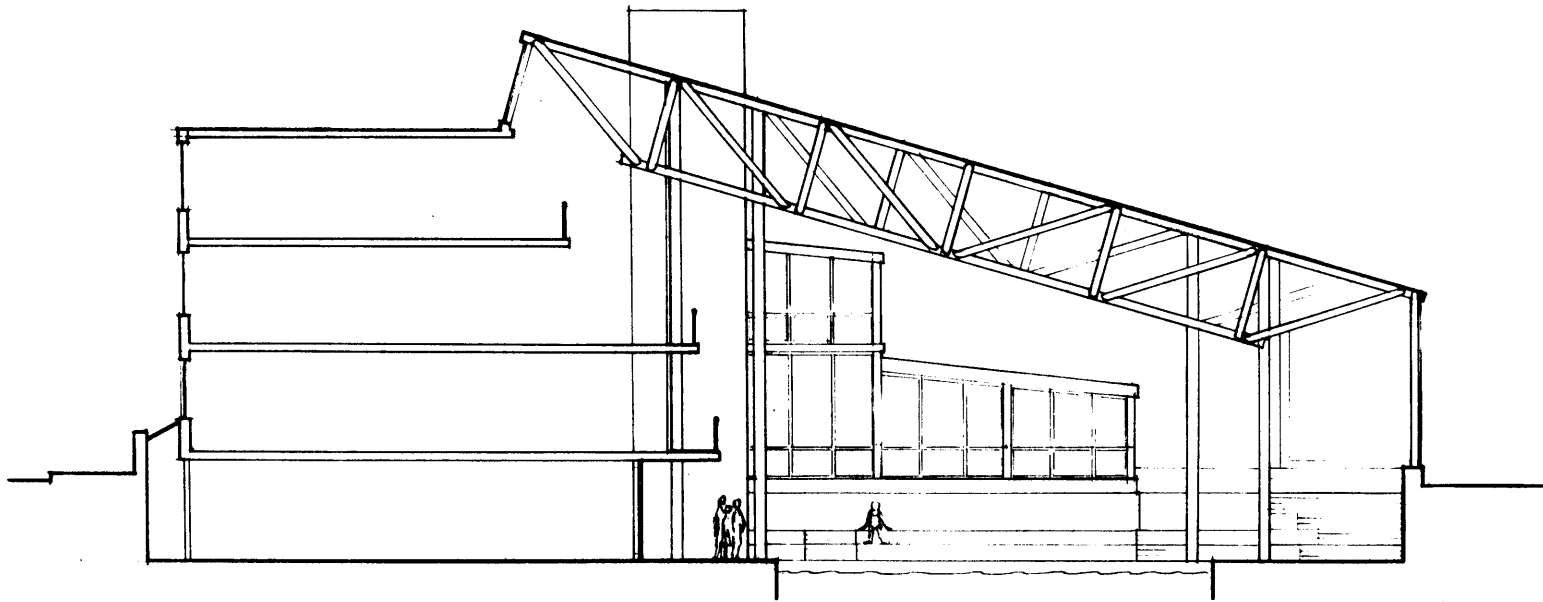

section C

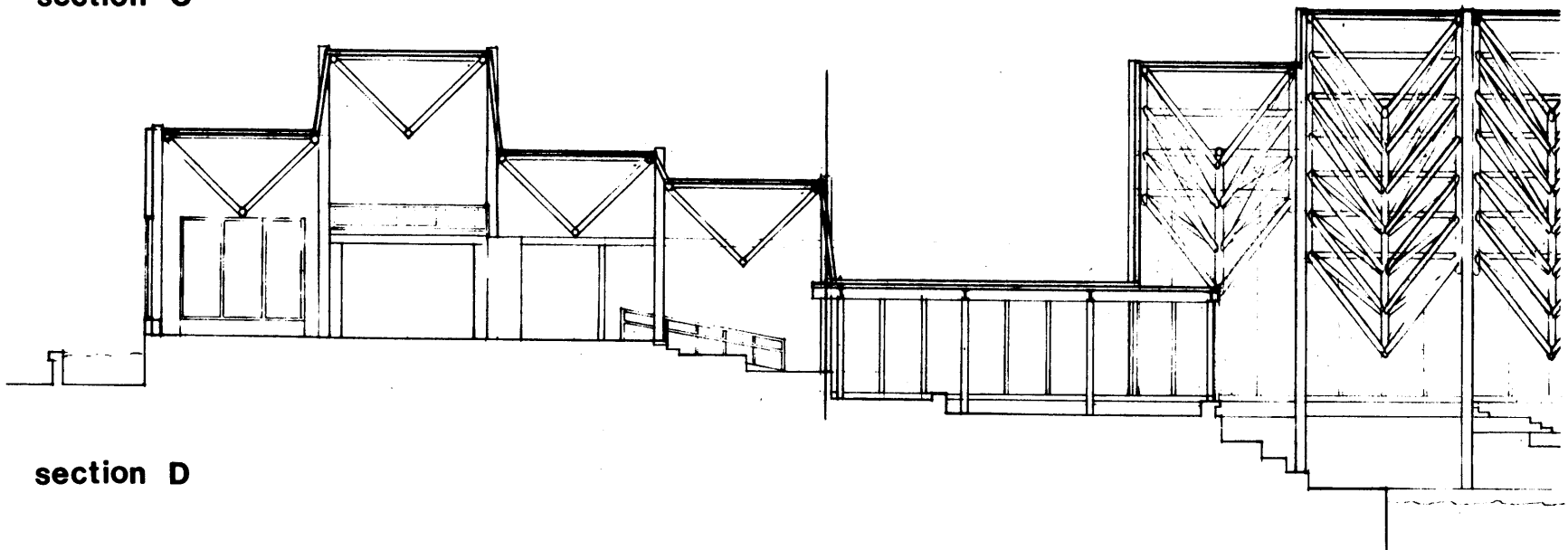

section D

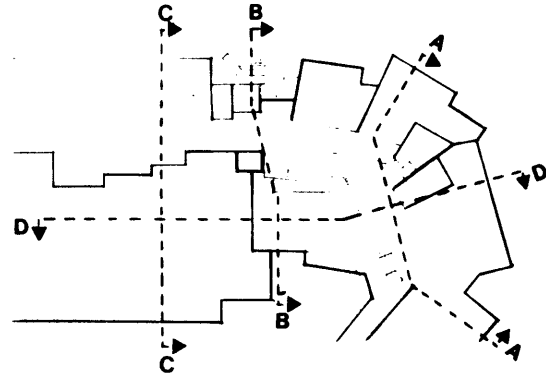

SECTION KEY

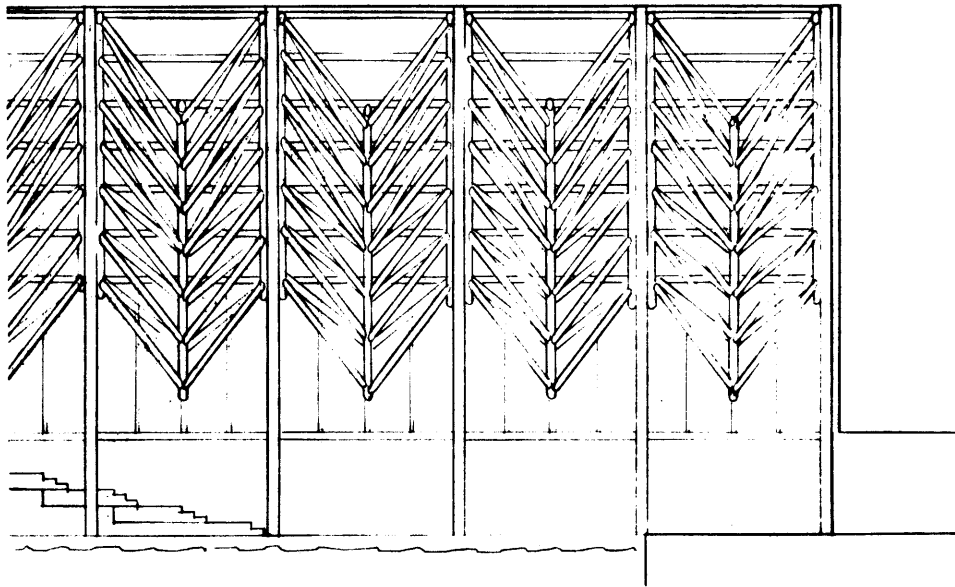

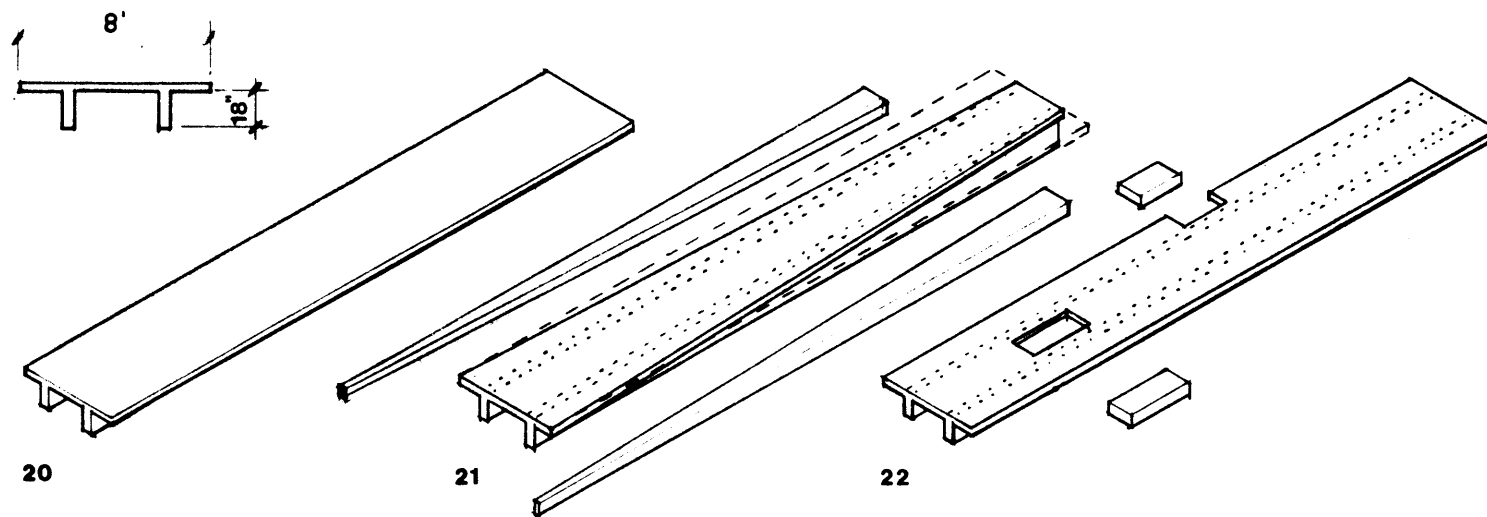

THE SPANNING ELEMENT

Physical Components:

economical spanning range - 40 ft.
to 120 ft.

width of Tee, 8 ft.; depth of ribs,
18 in. (for 50 - 60 ft. span),
(20)

supported by concrete beams, depth
2 ft.

piers (1 ft. 6 in. x 3 ft.) every
16 ft. - every 2 Tees

roof enclosure is inherent in Tee
itself

Tees can be angled at their edges
by inserting forms into mold dur-
ing casting process as long as
structural ribs remain intact (21)
holes for skylights or other pur-
poses made by forms in casting
process also (22)

CONCRETE DOUBLE TEE

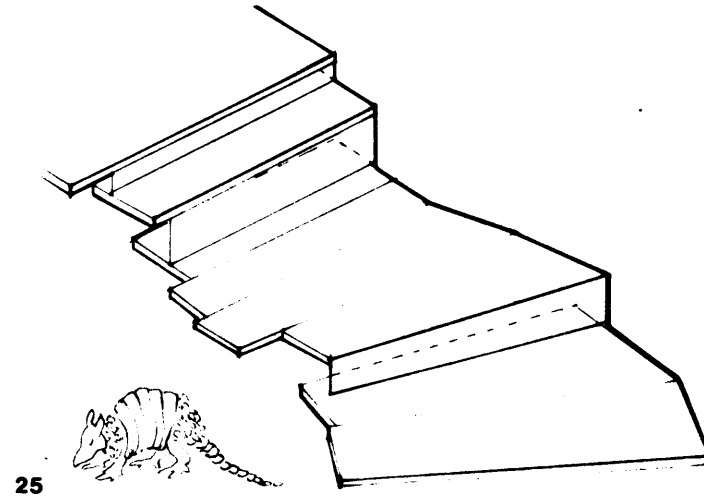
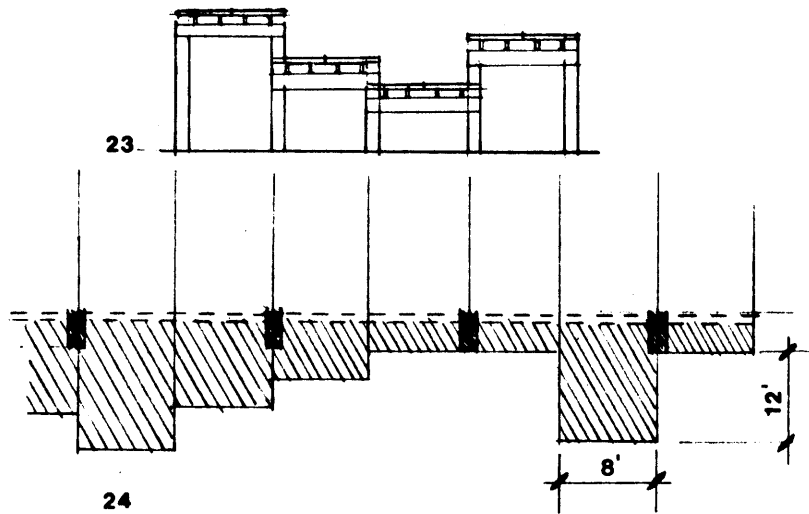

Personality:

The tee itself is uninteresting. Articulation of detail is possible through emphasis of the supporting elements, the columns and beams. It lends itself to heavy, cave-like spaces. Moreover, most light must enter through walls or other infill roofing systems.

Because the piers occur every 16 ft., the roof can step vertically at those intervals (23).

The Tees can cantilever and thus allow space to flow beyond the piers. This creates opportunities for more intimate scale zones (24)

Tees can be shifted laterally, vertically and can turn radially. They can be thought of as the outer scales of an armadillo - adjusting themselves to the odd movements of the body (25).

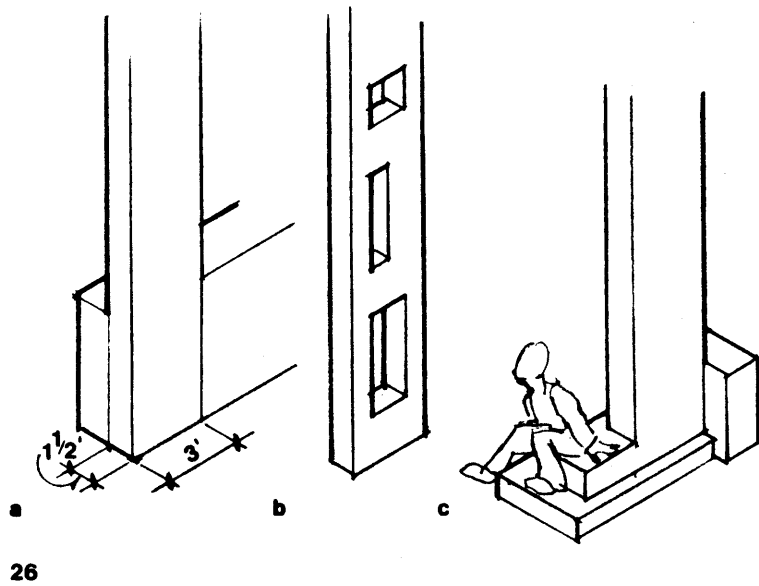

26

Industrialization:

The same mold is used irrespective of length and type of inserts, the concrete beams and piers are standard.

PIERS

- give partial wall definition (26a)
- can be decorative (26b)
- can appear to grow out of the floor with "roots" providing natural places for people and plants (26c)

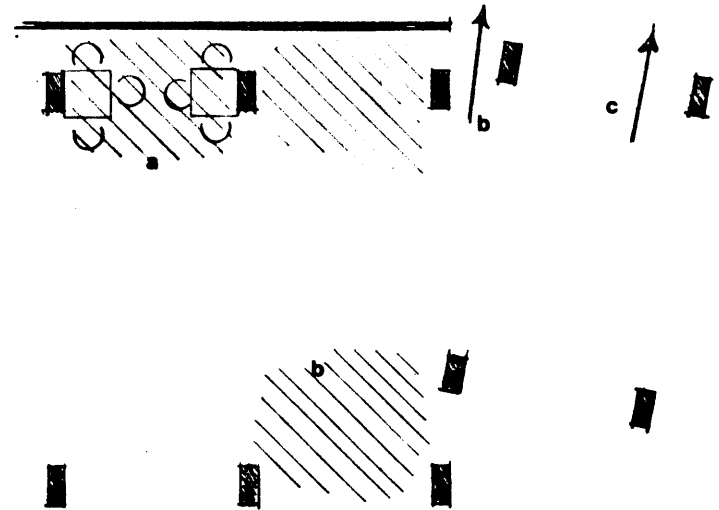

27

- create bays - smaller zones off the main space (27a)
- when two families of piers come close together they create special places: gateway or larger bay (27b)
- allow directional views out to park (27c)

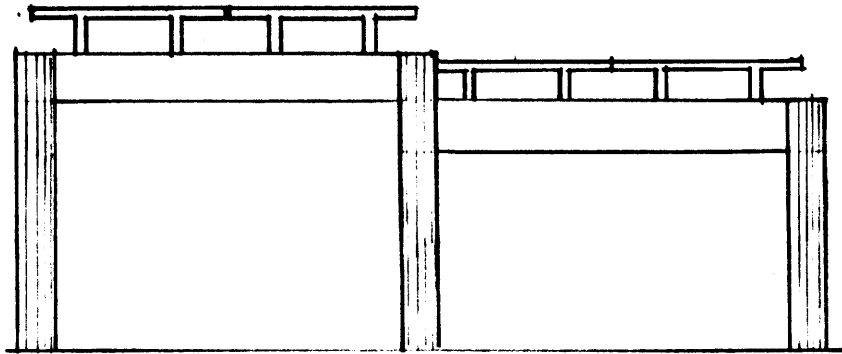

ELEVATION

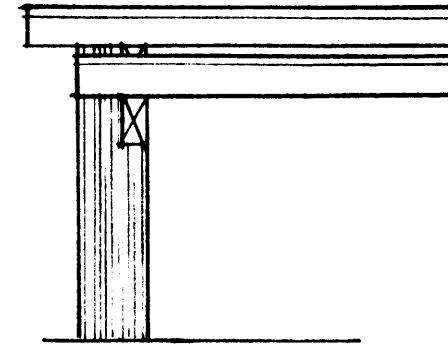

SECTION

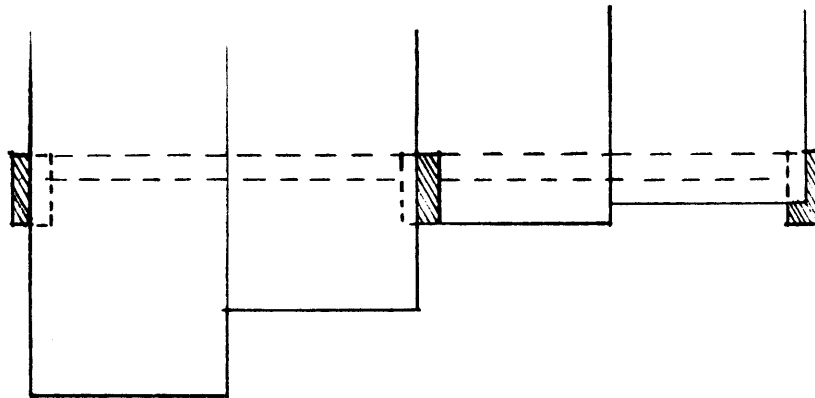

PLAN

Two beams come into same pier at different levels and create step in roof line.

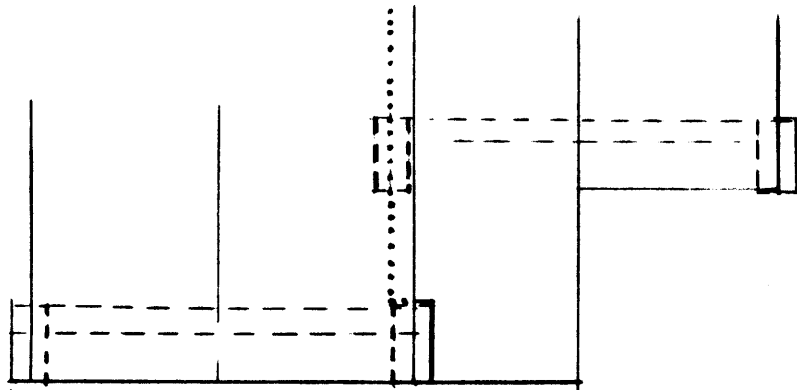

PLAN

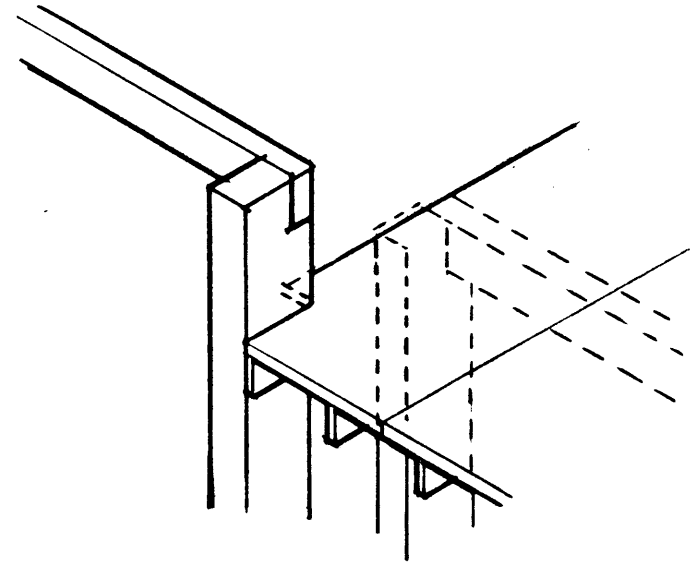

ISOMETRIC

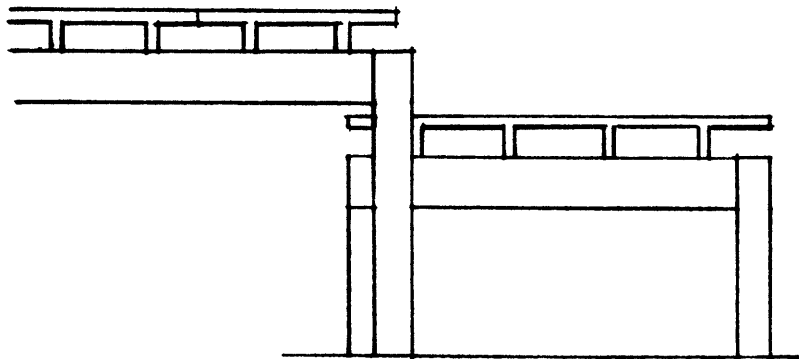

ELEVATION

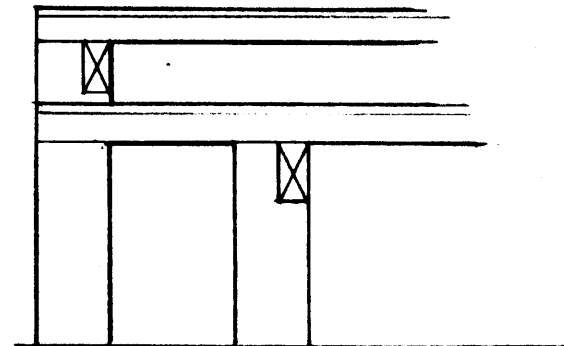

SECTION

Different sets of piers don't line up.
Beams and Tees step down and pier line
shifts laterally.

The isometric drawing shows how the Tee
is precast with its corner cut out so
that the pier can come up through it.

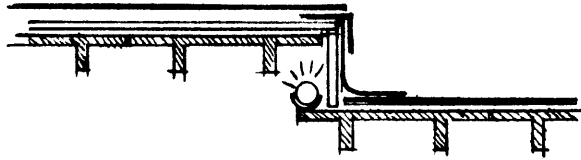
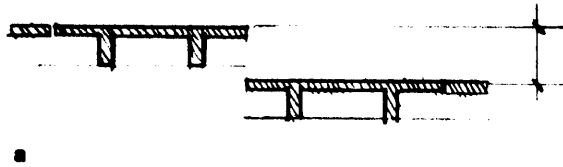

28

b

When Tees step down there must be at least a 3 ft. height difference to fit in a small clerestory window (28a). Roof flashing and window framing consume approximately 2 ft. of space leaving 1 ft. for window glass. However, small stepping may be desired and it will provide opportunity for indirect artificial lighting (28b).

28

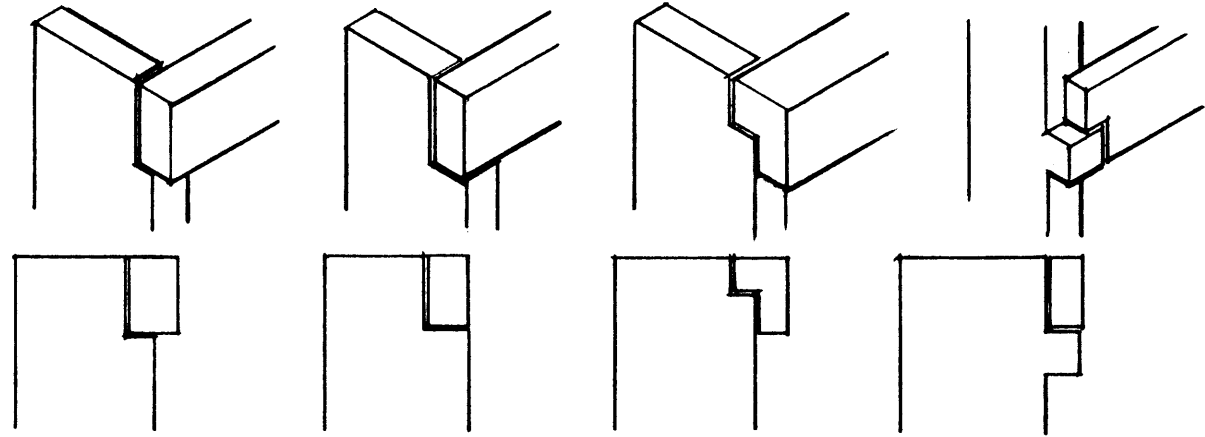

29

Beams can rest on piers in several ways (29). The post and beam system lends itself to an additive secondary system. The greenhouse will be constructed of another framing material, possibly wood (30). The trellis will be similar and will fan out slightly echoing the fanning of the Tees behind it.

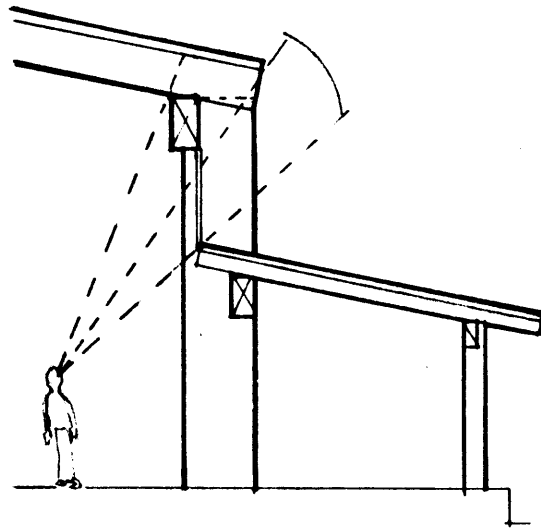

30 SECTION

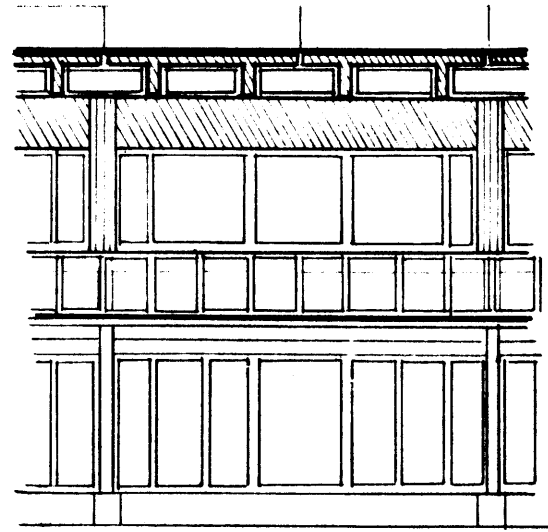

ELEVATION of greenhouse

Tees let light in only from edges (skylight, greenhouse, trellis and clerestories). Infill panels riding on beams between the ribs can be glass or solid material. In this position, due to the massive beams and piers, the glass would afford only indirect light without views to the sky. In this particular system of

massive support structure, any use of glass near the roof edge must be carefully considered with respect to the angle of vision of the users. The greenhouse can be framed into the concrete piers at a sufficiently low height to allow good clerestory windows.

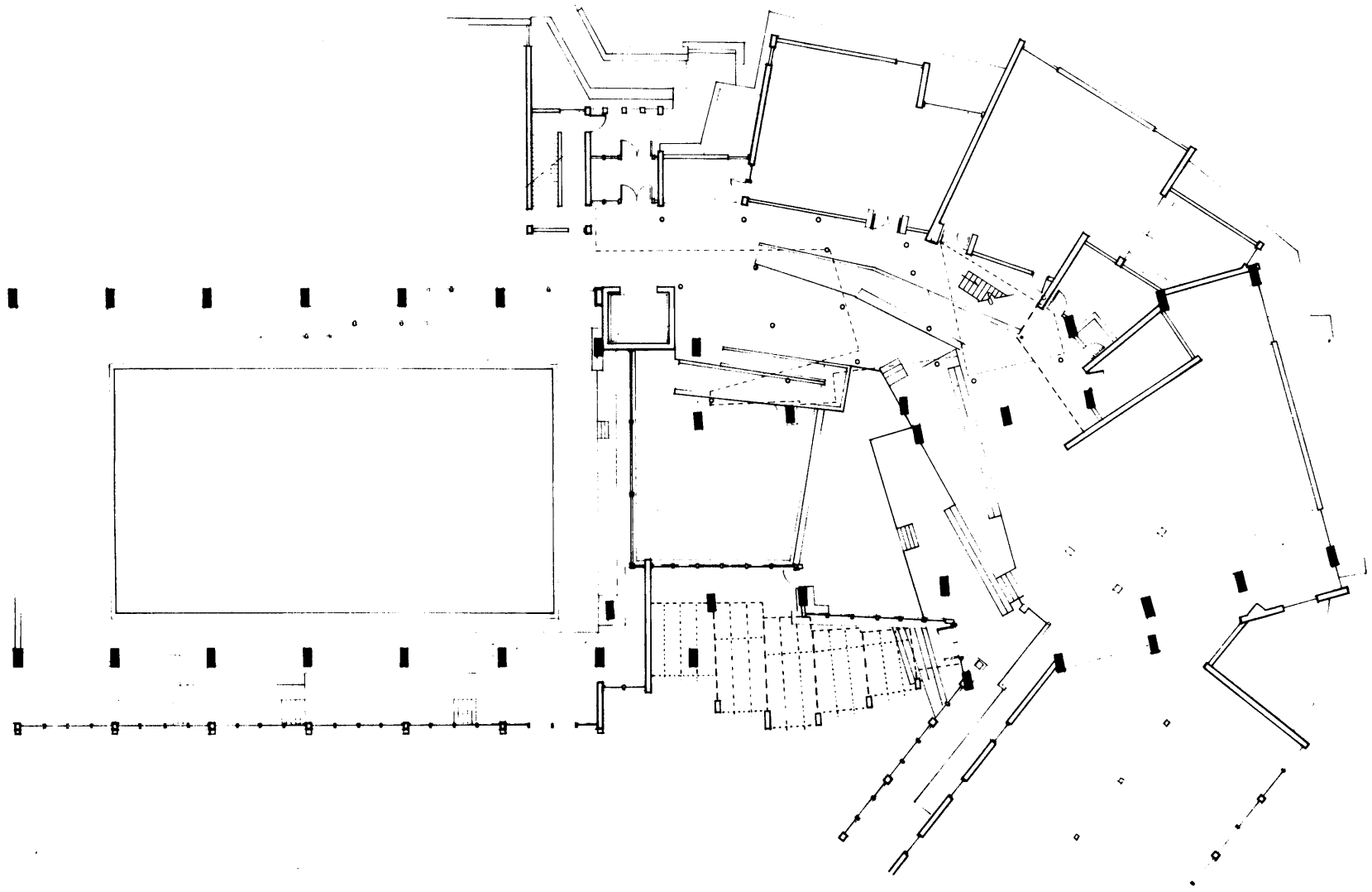

plan

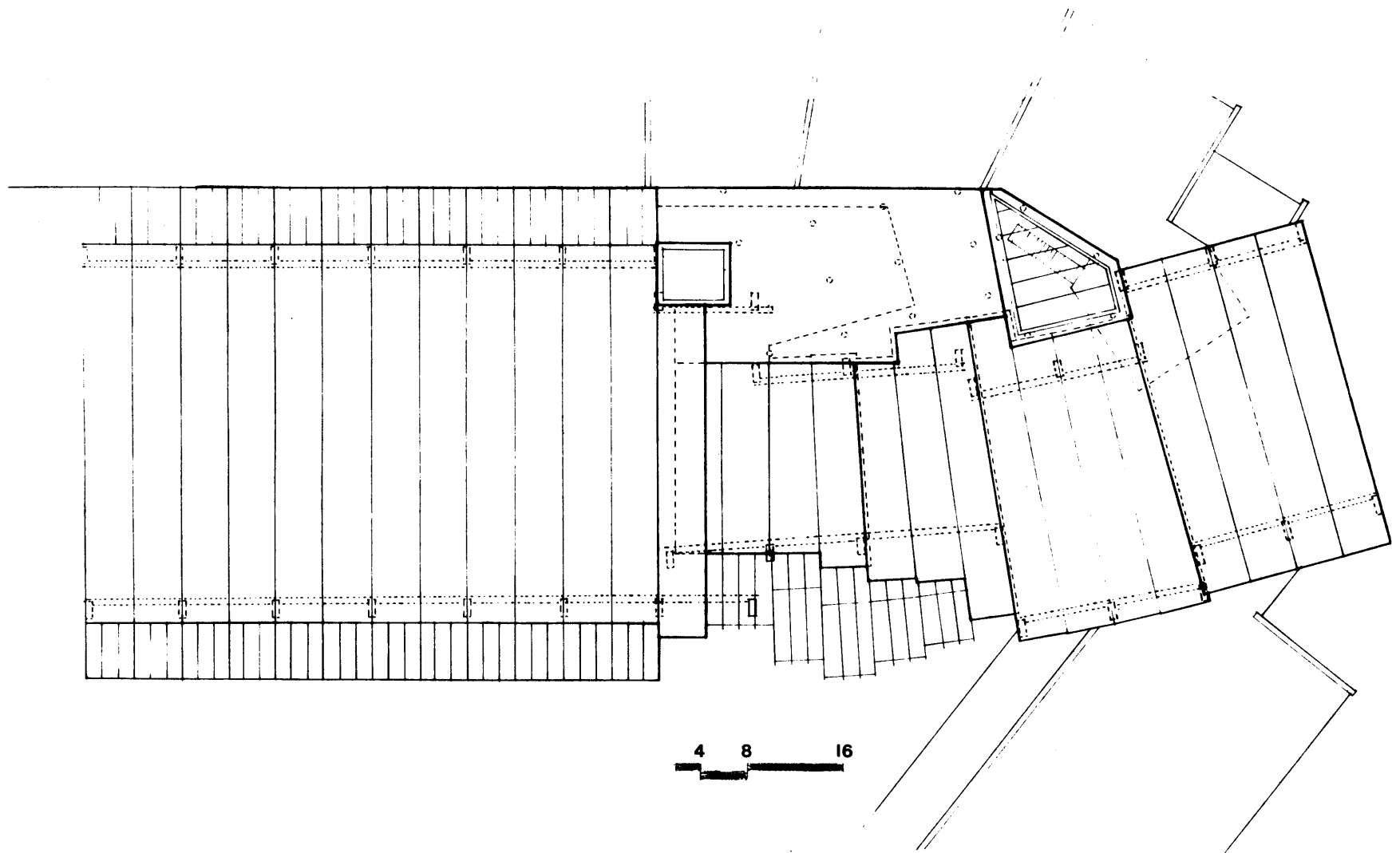

32 structural roof plan

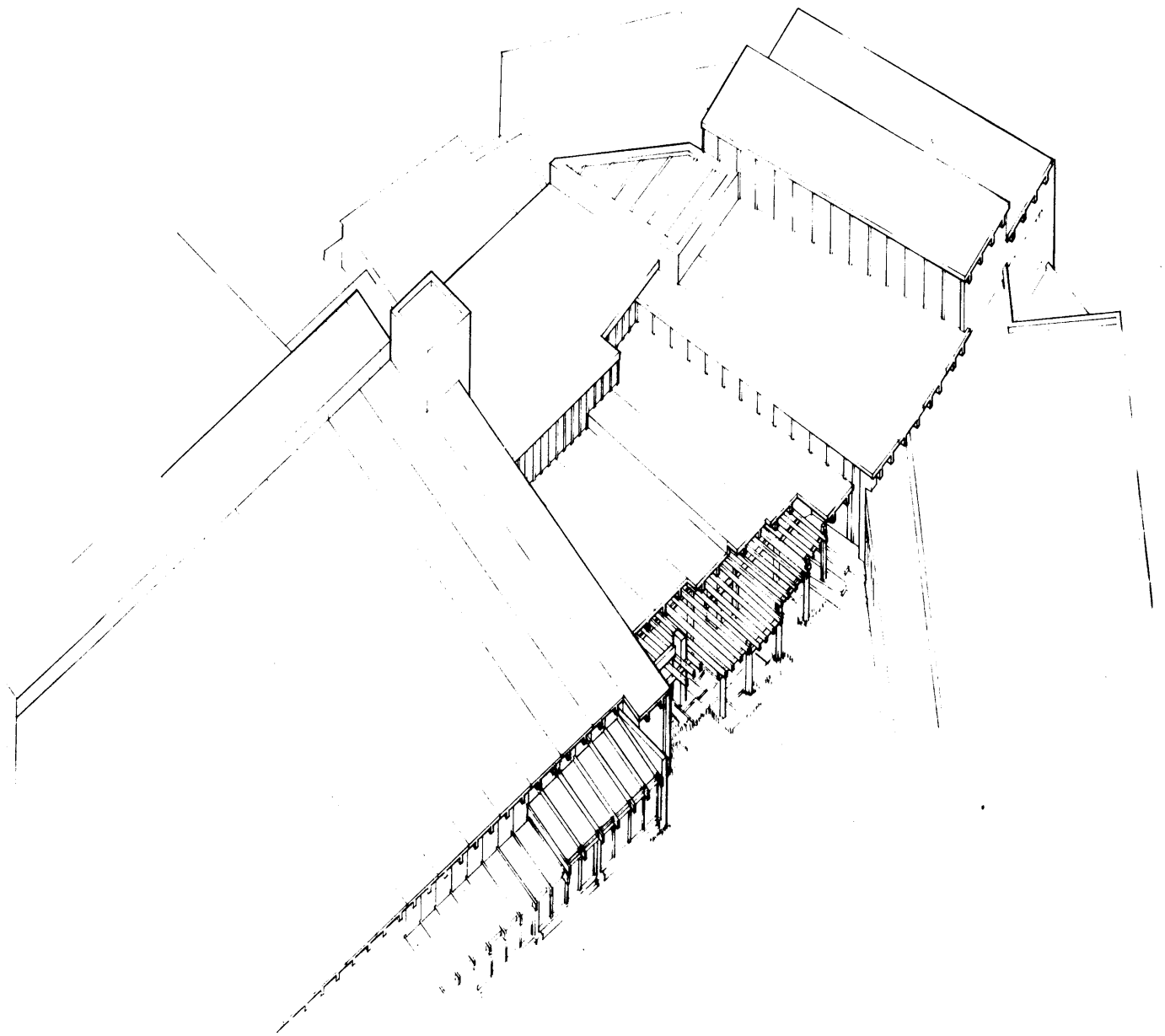

isometric

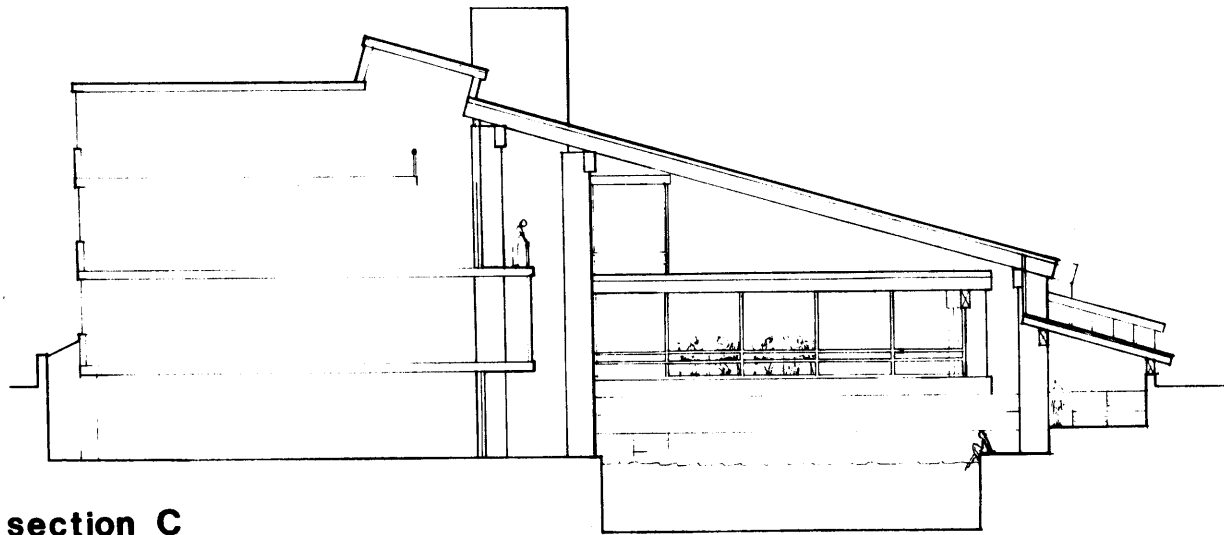

section C

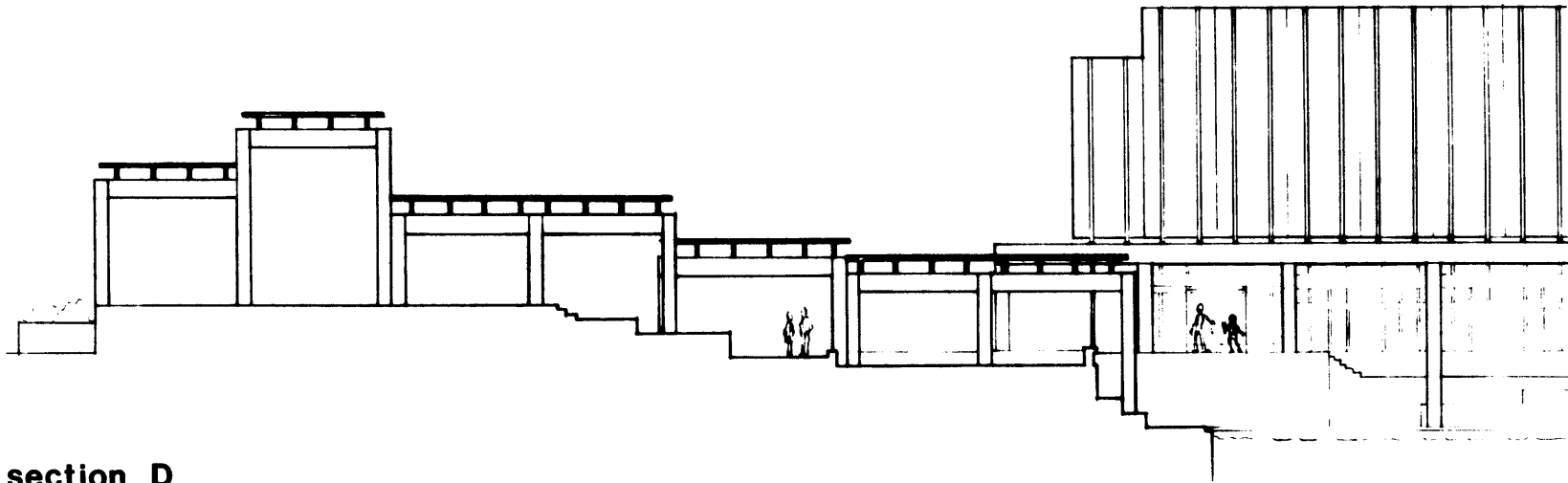

section D

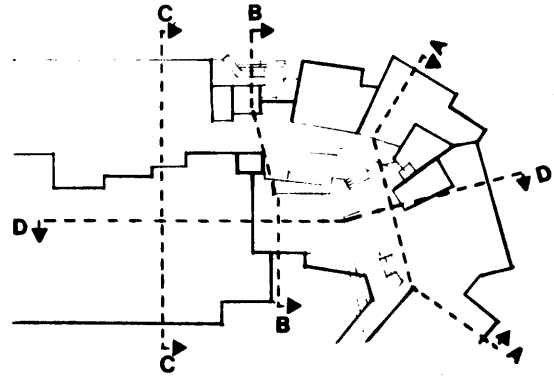
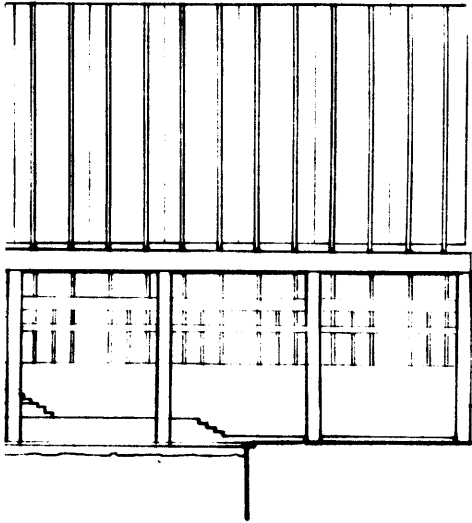

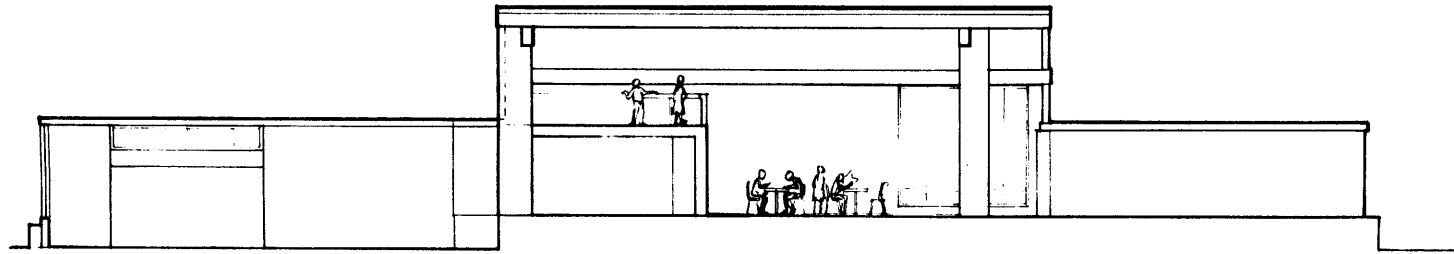

section A

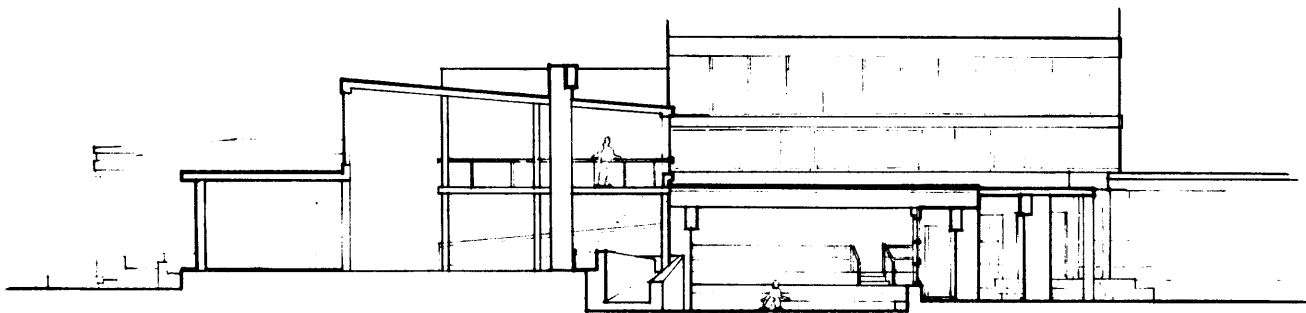

section B

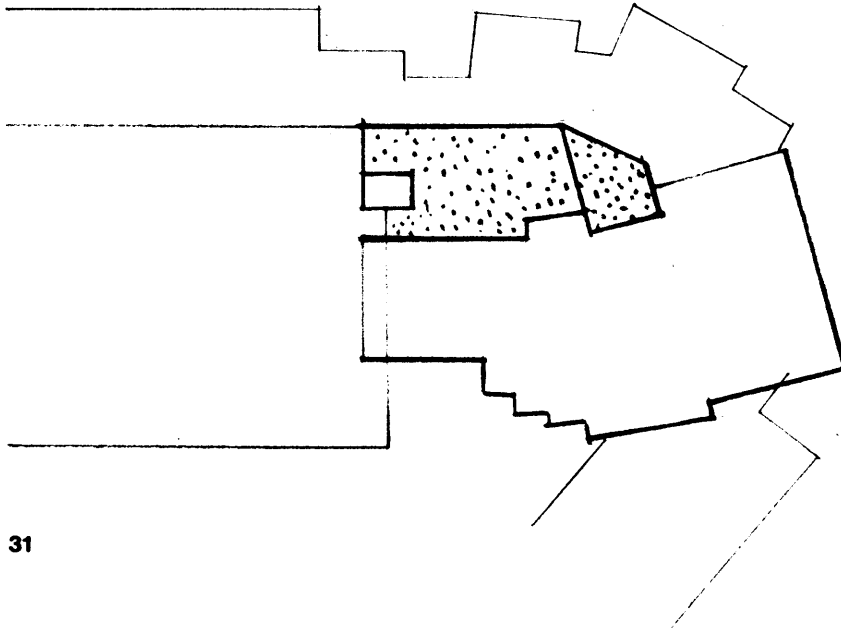

31



32

INFILL SYSTEM

The Tees lend themselves to turning the angle between the pool and the dining room. Due to the extensive application of the Tees, the area covered by an infill system is reduced to the skylight and balcony area (31).

The infill system will be cast-in-place concrete and can be envisioned as a larger protective plate of the Tees fanning out from below it (envision the armadillo).



33

The grid of the columns of the cast-in-place system follows the direction of the dining hall (32) while the edges of the roof slab mimic the changing directions of the Tees (33) and, as are the Tees, is dominated by the direction of the pool.

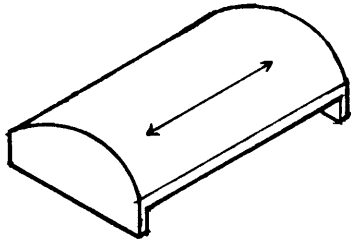

34

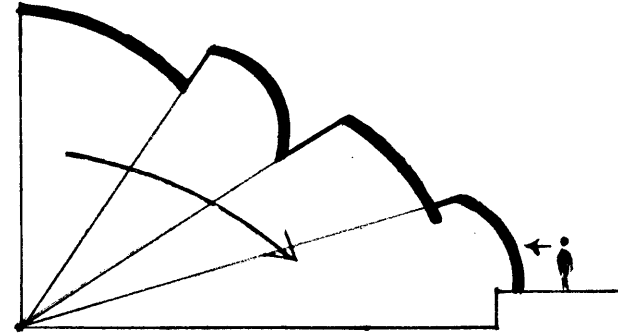
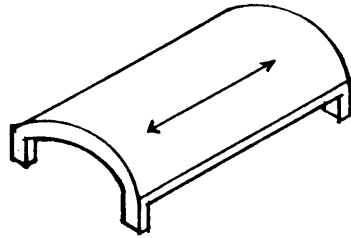

35

This chapter describes an evolution of a solution of the construction of an envisioned curved structure using an industrialized building system.

The third roof was envisioned as a surface structure consisting of four shells spanning between two ribs or walls (34). The shells were positioned to

catch the north light and have a gently illuminated curved ceiling over the pool. The clerestory windows unfold successively as if fanning out from a central point (35). All the shells have slightly different radii of curvature due to this idea.

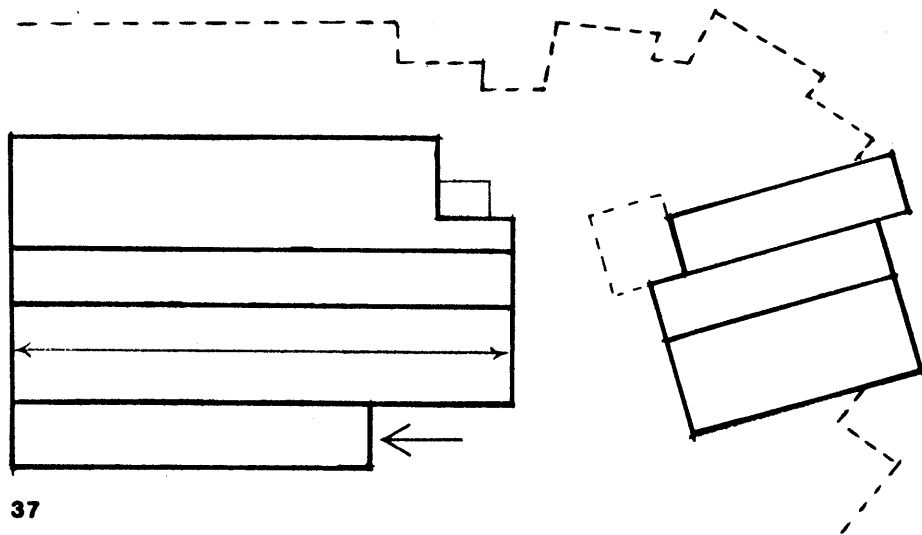

37

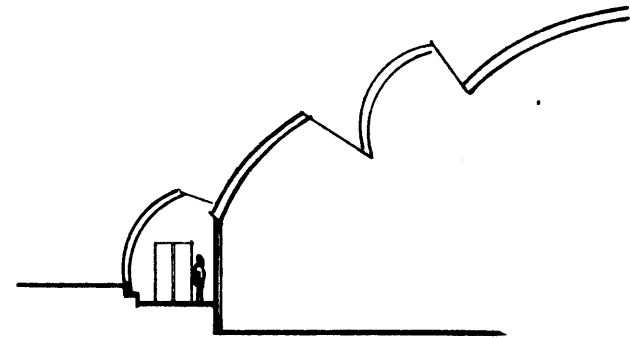

38

SHELL CHARACTER

The span of the system is now parallel to the pool contrasting with the two earlier systems which spanned the pool perpendicularly (37). This contrast enabled me to see that the first two systems hadn't altered the plan very much as there weren't any directional confrontations. With the shell roof, entry from the park side of the pool is very uncomfortable. The last shell is shortened so that the door can be at its end

wall. Rather than face an impenetrable mountain form, one now enters from the "side of the hill" that has been cut away (38).

Other shifts can be made in this direction. In the dining area - one shell is shifted out to the street to respond to the skylight. At the street edge an opportunity is now found to

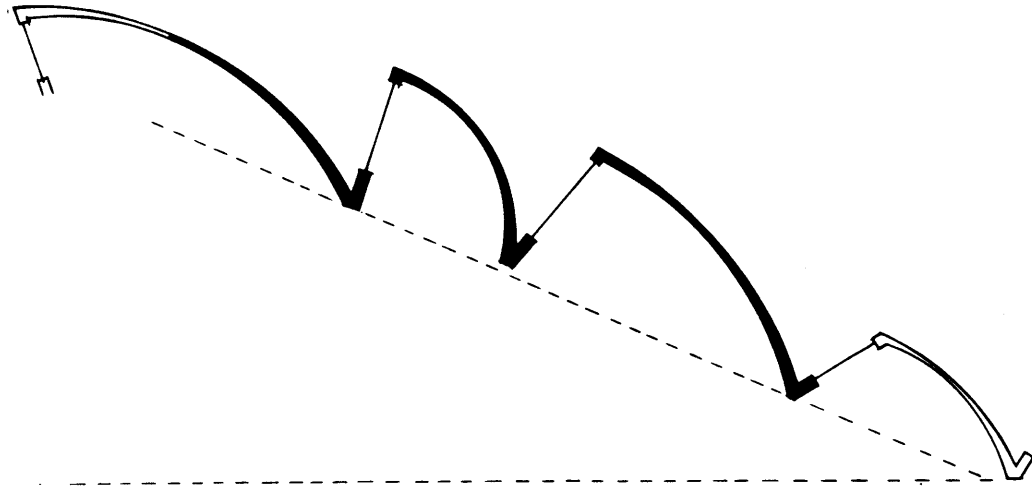

SECTION THRU POOL ROOF

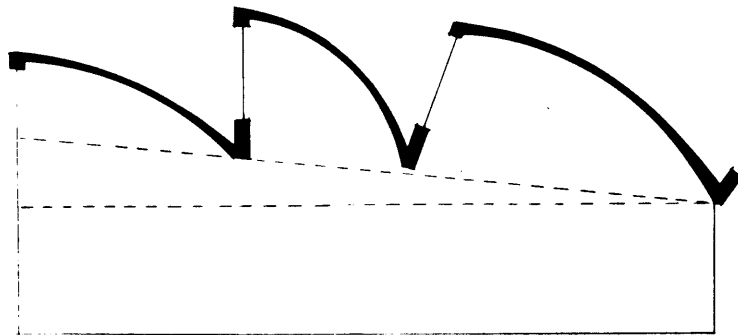

SECTION THRU DINING ROOM ROOF

CONSTRUCTION OF THE SHELL

The shell form desired has four unequal curves, all at different angles with different sized clerestory windows. However, this section remains constant throughout and is repeated even in the dining area roof with just a slight angle change of the whole configuration.

This could be built as an extruded process. The form would be built on scaffolding resting on wheels. It would be rolled along while the roof was built in slip-form fashion (39). This involves much on-site-labor and is not practical in the U.S.A.

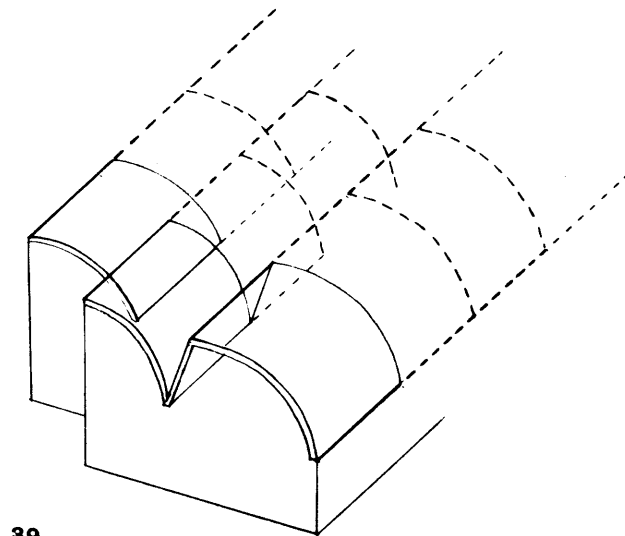

39

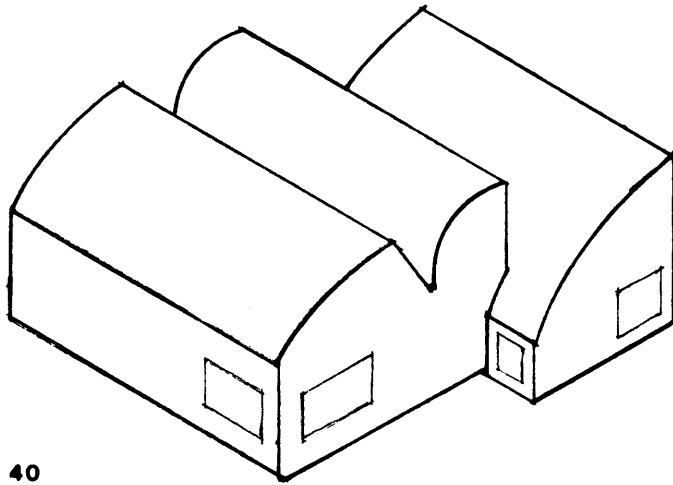

40

create a smaller intimate space because of this (40). In this system there are no columns to create smaller zones. The end walls or structural ribs every 30 ft. are the only elements to touch the floor. Because of the longer intervals it is more difficult to find opportunities for creating small scale spaces.

The ribs every 30 ft. in pool area can be made into walls dividing up the greenhouse edge of the pool into smaller "rooms." The roof supports at the park

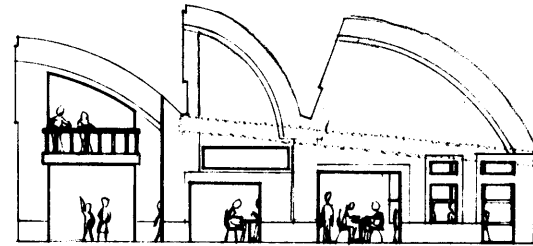

ELEVATION "screen" wall

side of the dining area can be made more into a wall and with the roof can emphasize the light well of the skylight. The rest of the wall can become a screen with large holes cut into it for passageways and windows.

Now the dining area with soft north light and a wall (with many holes for views) between it and the park changes its character totally. It is more of an inward, self-contained space.

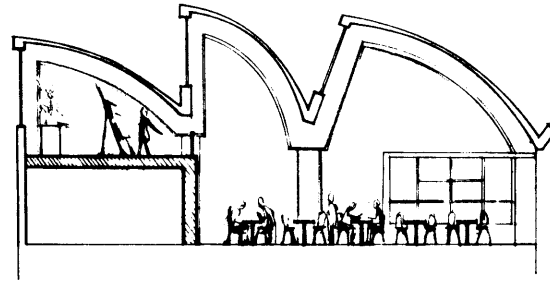

section A

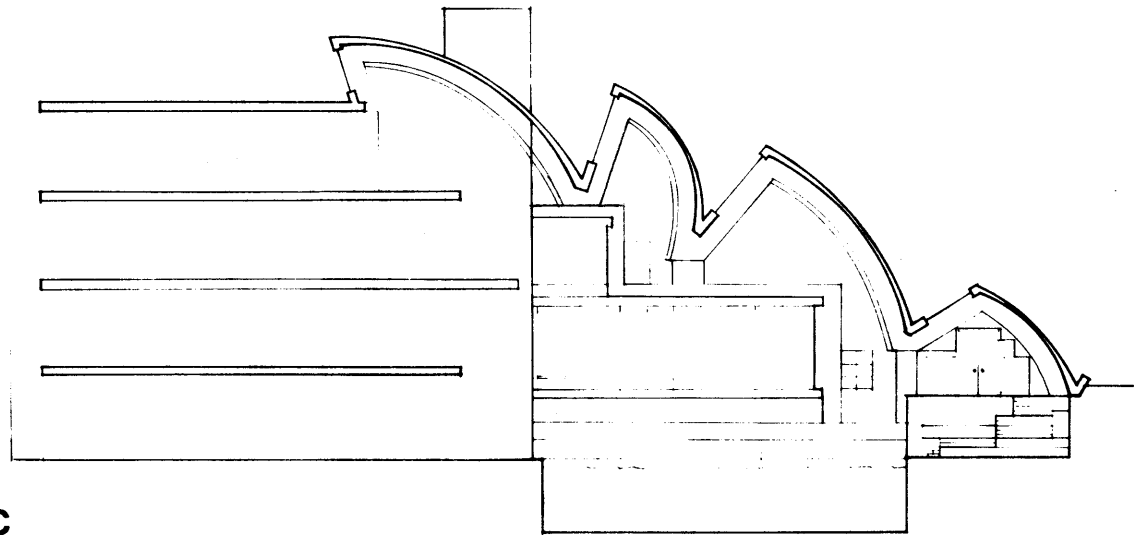

section C

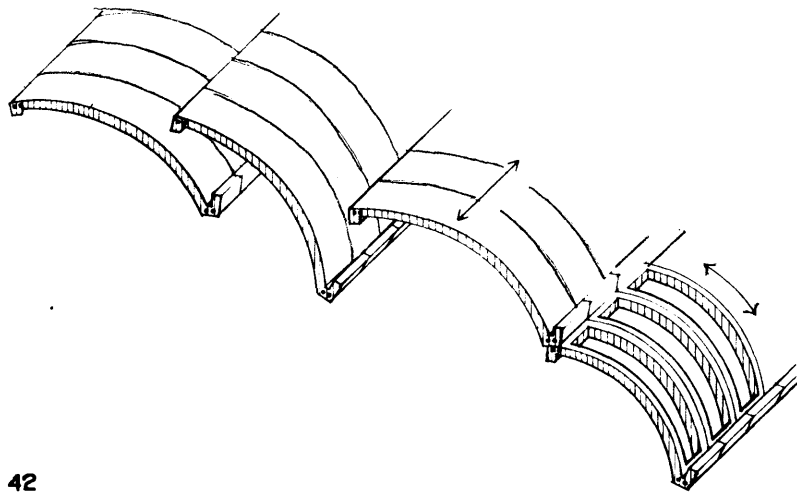

42

INDUSTRIALIZATION OF THE SHELL FORM

OPTION ONE

This system is based on a roof system by Waclaw Zalewski.

Description:

Each shell is made from the same pre-cast section 5 ft. wide made in factory. The sections are post-tensioned together on site. Sections rest on structural ribs located every 30 ft. Ribs may be precast standard pieces or custom made.

Limitations:

Due to expense of mold each shell will have the same section. The multicurved roof will be composed of several shells all of the same diameter (42).

The last shell (closest to park) can be made of sections that are actually more like concrete frames than shells. In this way they can accommodate large

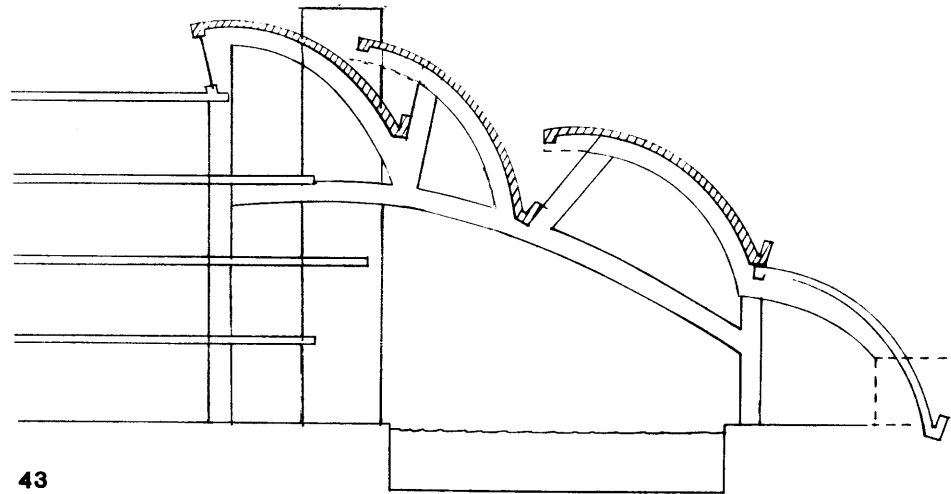

windows for the greenhouse. No longer acting as shells they would span from the shell next to it to the ground. This is possible.

The shell sections can be arranged so that the roof gives the appearance of unfolding and having different size curves in its composition. However, this is very awkward and doesn't really work for the clerestory win-

dows. Also, the rib structure must now support a variety of levels of shells and looks unattractive as well as becoming a very costly item to construct (43).

Conclusion:

The constant section of the shell pieces constrained the roof so much that the original idea is lost.

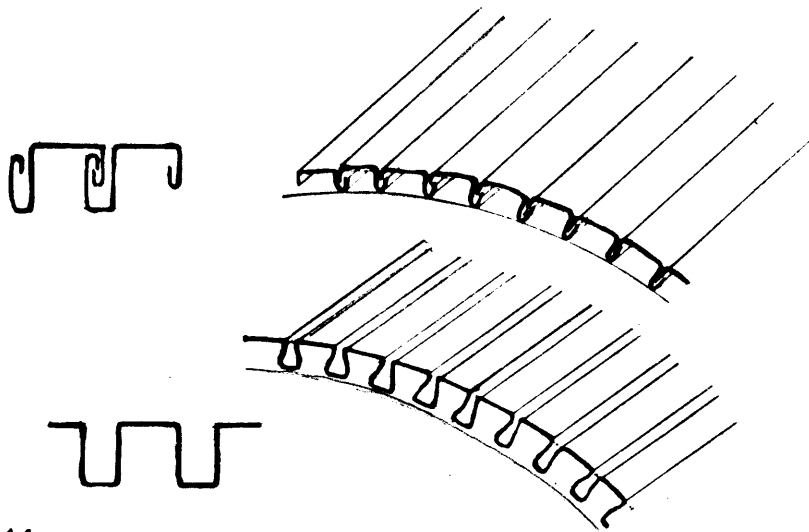

44

OPTION TWO

This system also credited to Waclaw Zalewski.

Description:

The roof enclosure is corrugated metal (a) and spans 6 ft. between light-weight structural ribs (b). These are custom formed at factory and determine the shape of the roof curve and can be made of metal or wood.

These ribs in turn sit on concrete precast channels which span 30 ft. (c). These are the "gutters" of the original shell structure. The reinforcing ribs have now become standard concrete posts and beams (d) as ribs can now rest along a single beam line.

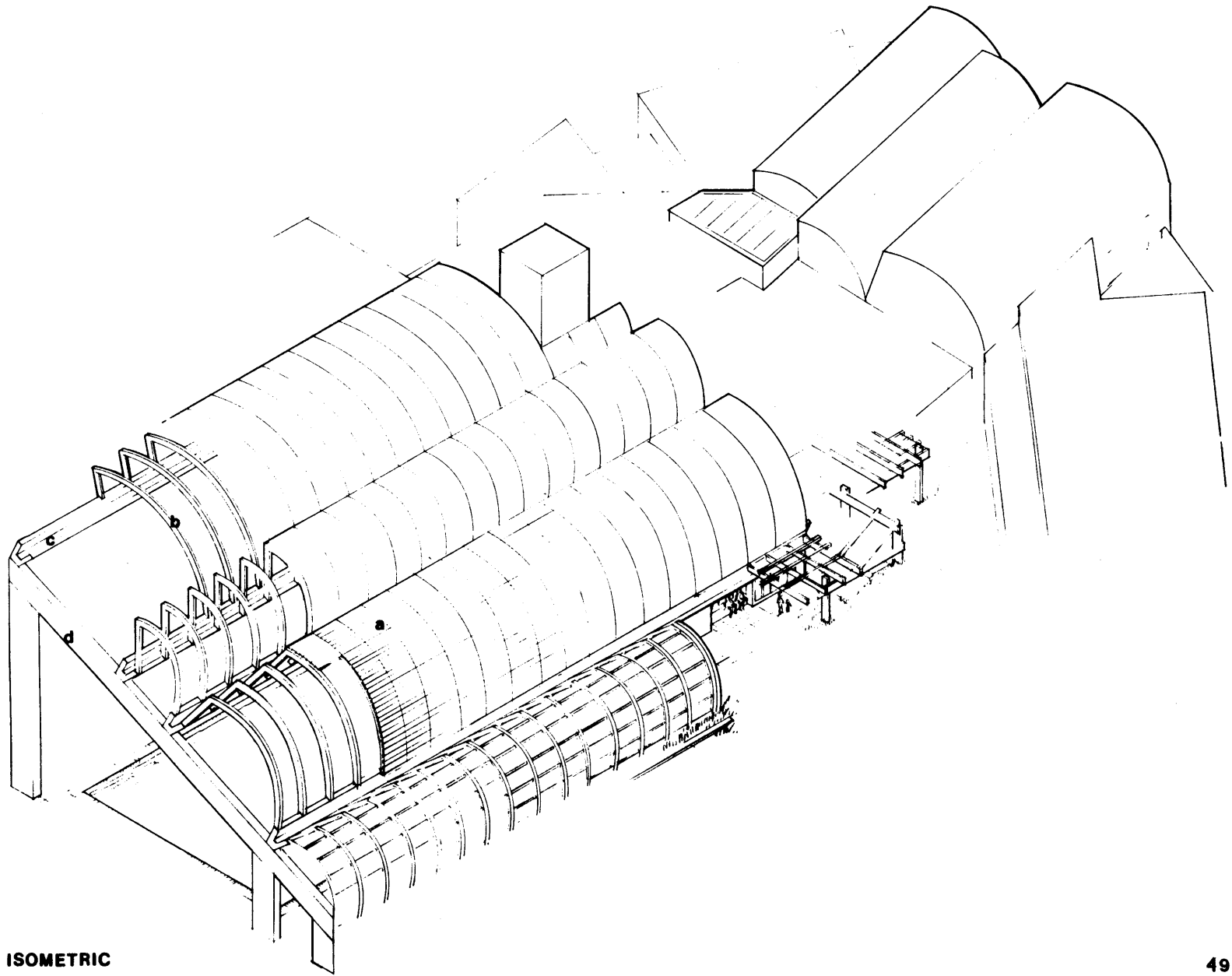

ISOMETRIC

CONCLUSION

All custom parts are made in factory and are relatively light weight. The enclosure is now separated from the roof structure and doesn't determine the curve itself. It can form any curve due to its corrugations (44). The shell is only being simulated as an idea for a quality and feeling of space.

The quality of a surface structure - smooth and uncluttered - is now gone. The system in the second option will have some of the light, airy qualities of the truss and some of the heavier qualities of the support systems of the Tees, and yet it is an enclosure that is less determined by its supports.



plan

This exercise explored the architectural possibilities of a three dimensional steel truss, concrete double Tees, and the industrialized construction of a shell form. All of these systems seemed unlikely coverings for the free form plan of the building. My goal was to use standard parts available from the construction industry to create unusual forms. All these systems proved to be very stiff. Pushing the various systems to their architectural limits demonstrated the qualities possible within each system.

- Angerer, F. Suface Structures in Building. Rienhold Publishing Corp., N.Y., 1961.
- Banham, R. Guide to Modern Architecture. London Architectural Press, London, 1962.
- Blaser, W. Struktur und Textur. Krefeld: Scherpe, 1976.
- Diamant, R.N. Industrialized Building. Ilffe Books, Ltd., London.
- Fleig, K., ed. Aalto. Praeger Publishers, N.Y., 1975.
- Gatz, K. Modern Architectural Detailing, vol. 1-5. Reinhold Publishing Corp., N.Y., 1967.
- Gubitosi and Izzo. Eduardo Catalano, Buildings and Projects. Rome, 1978.
- Hornbostel, C. and Bennett. Architectural Detailing. Reinhold Publ. Corp., N.Y., 1952.
- Hornbostel, C. and Hornung, W. Materials and Methods for Contemporary Construction. Prentice-Hall, Inc., N.J. 1974.
- Huntington. Building Construction. John Wiley and Sons, N.Y., 1941.
- Pevsner, N. Sources of Modern Architecture. Oxford University Press, c. 1968.
- Schodek, D. Structures and Buildings. Harvard Graduate School of Design, unpublished, 1976.
- Scully, V. Modern Architecture. G. Braziller Co., N.Y., 1974.
- Standard Steel Joist Institute, Open Web Steel Joists, catalogue--G & H series.
- Sweet's Catalogue Service. Architectural Catalogue File. F.W. Dodge Corp., McGraw Hill, 1972.
- Torroja, E. The Structures of Eduardo Torroja, F.W. Dodge Corp., N.Y., 1958.
- van Ettinger, J., ed. Modern Steel Construction in Europe. Elswier Co., N.Y., 1963.

BIBLIOGRAPHY