



# MIT Open Access Articles

## *Exergy analysis of incremental sheet forming*

The MIT Faculty has made this article openly available. **Please share** how this access benefits you. Your story matters.

<b>Citation</b>	Dittrich, M. A. et al. "Exergy Analysis of Incremental Sheet Forming." Production Engineering 6.2 (2012): 169–177. CrossRef. Web.
<b>As Published</b>	<a href="http://dx.doi.org/10.1007/s11740-012-0375-9">http://dx.doi.org/10.1007/s11740-012-0375-9</a>
<b>Publisher</b>	Springer Science + Business Media B.V.
<b>Version</b>	Author's final manuscript
<b>Citable link</b>	<a href="http://hdl.handle.net/1721.1/78370">http://hdl.handle.net/1721.1/78370</a>
<b>Terms of Use</b>	Creative Commons Attribution-Noncommercial-Share Alike 3.0
<b>Detailed Terms</b>	<a href="http://creativecommons.org/licenses/by-nc-sa/3.0/">http://creativecommons.org/licenses/by-nc-sa/3.0/</a>

# Exergy Analysis of Incremental Sheet Forming

M.A. Dittrich<sup>1</sup>, T.G. Gutowski<sup>1</sup>, J. Cao<sup>2</sup>, J.T. Roth<sup>3</sup>, C. Xia<sup>4</sup>, V. Kiridena<sup>4</sup>, F. Ren<sup>4</sup>, H. Henning<sup>5</sup>

<sup>1</sup>Laboratory for Manufacturing and Productivity, Massachusetts Institute of Technology, 77 Massachusetts Avenue, MA 02139 Cambridge, USA, T. Gutowski: gutowski@mit.edu, M.A. Dittrich: mdittric@mit.edu

<sup>2</sup>Dept. of Mechanical Engineering, Dept. of Civil and Environmental Engineering, Northwestern University, 2145 Sheridan Rd. Evanston, IL 6020, USA

<sup>3</sup>Mechanical Engineering Faculty, Penn State Erie, The Behrend College 5091 Station Road Erie, PA 16563 Erie, USA

<sup>4</sup>Ford Research and Innovation Center, MI 48124 Dearborn, USA

<sup>5</sup>Institut für Fertigungstechnik und Werkzeugmaschinen, Gottfried Wilhelm Leibniz Universität Hannover, An der Universität 2, 30823 Garbsen, Germany

## Abstract

Research in the last 15 years has led to die-less incremental forming processes that are close to realization in an industrial setup. Whereas many studies have been carried out with the intention of investigating technical abilities and economic consequences, the ecological impact of incremental sheet forming (ISF) has not been studied so far.

Using the concept of exergy analysis, two ISF technologies, namely single sided and double sided incremental forming, are investigated and compared to conventional forming and hydroforming. A second exergy analysis is carried out with the purpose of examining the environmental impact of different forming technologies from a supply chain perspective. Therefore, related upstream activities (die set production, aluminum sheet production and energy conversion and supply) are included into the exergy analysis. The supply chain is modeled with a newly developed Simulink blockset.

The results of both analyses suggest that ISF is environmentally advantageous for prototyping and small production runs.

**Keywords:** incremental sheet forming, exergy analysis, degree of perfection

## 1 Introduction

Sheet metal forming processes are used in diverse industries, e.g. aero, automobile and medical. Recently, these industries have shown an increasing demand for small lot production, tailor-made parts and prototypes. Whereas solutions for flexible machining already exist, for instance production centers, sheet metal forming is still characterized by processes that are economically advantageous for large batch production only. Above all, high cost and time for the development and production of dies limit conventional

sheet metal forming processes to large production runs [1]. Due to the problems in small lot production, aerospace industry frequently replaces forming processes by machining processes in order to eliminate the need for costly die sets. As a consequence, up to 95% of the material is machined away [2], which has both a negative financial and environmental impact.

In order to overcome the limitations of conventional drawing processes, alternative sheet metal forming techniques like single sided (SSIF) and double sided incremental forming (DSIF) have been developed. These processes use one or two numerically controlled tools that form the sheet material according to a programmed tool path (Fig. 1).

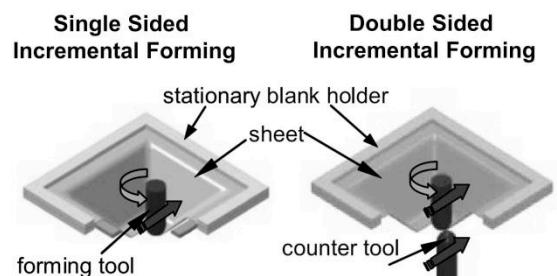

Fig. 1 Single and double sided incremental forming [3]

Advantages of the technology are high process flexibility, relatively low hardware costs and enhanced formability [1, 3 – 5]. Compared to conventional sheet metal forming, ISF enables production of even complex shapes without costly die sets. Considering that the delivery time for prototyping dies can be up to 10 weeks [6a], a die-less forming process leads to a significant lower time-to-market. Applications for which ISF would be especially useful include prototyping and small-lot production for automobile, aerospace and biomedical industries [4, 7]. In recent years, there have been many studies on technical improvements of ISF. An

overview can be found in [3, 4]. Nevertheless, most of these studies focus on the higher flexibility and technical advantages rather than on the environmental effects of ISF.

Aiming to investigate the environmental effects, three different samples are made from aluminum and steel sheets by SSIF while forces, tool displacements and electric energy consumption are measured. Afterwards, power measurements of DSIF are conducted in order to evaluate the performance of both forming modes. The concept of exergy analysis is introduced and process efficiencies of SSIF and DSIF are determined and compared to sheet hydroforming and conventional forming with cast iron and plastic die sets.

After this, the system boundaries are drawn around the entire supply chain, enclosing all upstream activities that are related to the forming process and the material production. The results are used to relate the environmental impacts of ISF, hydroforming and conventional forming from a supply chain perspective. Additionally, potential CO<sub>2</sub> reductions are estimated.

## 2 Experimental Setup

The experiments are carried out on one of the first SSIF/DSIF machines developed at the Ford Research and Innovation Center in Dearborn, Michigan. The machine is based on two hexapods with 6 degree of freedom each. Additionally, the machine has a platform to enable movements in z-direction.

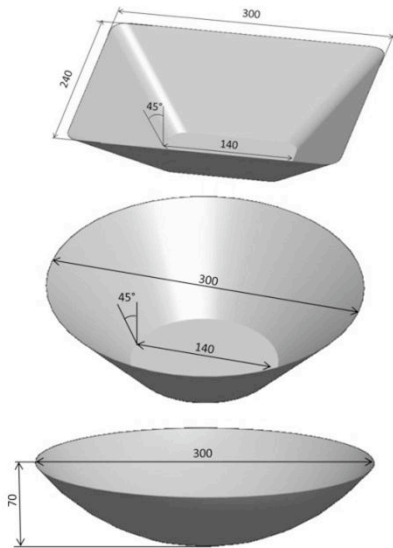

Fig. 2 Sample parts: box, cone and dome

Fig. 2 shows the three samples formed by SSIF. The aluminum alloy AA6022 and deep drawing quality (DDQ) steel are used as sheet materials (700 mm x 700 mm x 1 mm). Before forming, the sheets are greased with an oil-based lubricant. The forming styluses have a tool tip diameter of 10 mm. A circular tool path with an appropriate vertical step size in z-direction of 0.5 mm and a tool speed of 50 mm/s are chosen. The process forces are measured with a piezo-electric sensor, which is mounted to the tool center point. Using a three-phase power analyzer, the electricity inputs to the machine are measured.

## 3 Results

In case of SSIF 480 W are required for idle running (controller, power supply, relays etc.), 80 W for the positioning of the tool tip and 0–50 W for the actual forming process. The power measurements of DSIF result also in a consumption of 480 W for idle running, since the machine has just one control unit for both hexapods. The electric power required for positioning and forming increases to 160 W and 0–100 W, respectively. Fig. 3 summarizes the results.

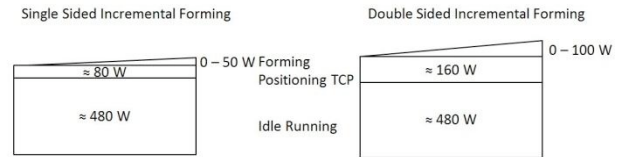

Fig. 3 Results power measurements of SSIF and DSIF

Using the measured forces, tool displacements and time data, the mechanical work requirements at the tool ( $W_{tool}$ ) can be calculated with Eq. 1.

$$W_{tool} = \int_{t_0}^{t_1} \vec{v} \cdot \vec{F} dt \quad \text{Eq. 1}$$

Table 1 gives an overview about  $W_{tool}$  and the measured electric energy consumptions ( $W_{in,SSIF}$  and  $W_{in,DSIF}$ ) of different samples and forming modes. Whereas  $W_{SSIF}$  and  $W_{DSIF}$  depend mostly on the processing time,  $W_{tool}$  is largely determined by material properties. It can be observed that  $W_{tool}$  is very small compared to the electric energy input. Over the entire forming process approximately just 16–22% of the total electric energy input is caused by the tool displacement and forming. The remaining electricity input is related to idle running processes.

Table 1 Electric energy consumption of SSIF and DSIF and mechanical work at the tool

Material	Energy Requirements					
	AA6022 (Thickness: 1 mm)			DDQ Steel (Thickness: 1 mm)		
Energy	$W_{in,SSIF}$ [MJ]	$W_{in,DSIF}$ [MJ]	$W_{tool}$ [MJ]	$W_{in,SSIF}$ [MJ]	$W_{in,DSIF}$ [MJ]	$W_{tool}$ [MJ]
Box	1.4	1.7	0.014	1.5	1.7	0.027
Cone	1.3	1.6	0.014	1.4	1.6	0.019
Dome	1.1	1.3	0.011	1.1	1.3	0.027

One way to calculate the process efficiency is to divide the minimum work required to form the sheet ( $W_{min}$ ) by the electric energy ( $W_{in}$ ).

$$\eta_f = \frac{W_{min}}{W_{in}} \quad \text{Eq. 2}$$

In a first approach  $W_{min}$  is approximated with  $W_{tool}$ . In case of forming the aluminum samples with SSIF and DSIF,  $\eta_f$  is estimated as 1% and 0.8%, respectively. More accurate results can be achieved when  $W_{min}$  is estimated by finite element analyses.

## 4 Exergy Analyses

Every manufacturing system has inputs, like energy and working materials, and outputs, like finished parts. Additionally, each system creates entropy and waste streams, which are dismissed to the environment. The concept of exergy analysis can be used to characterize and accumulate work, heat and material streams entering and leaving manufacturing systems [8a, 9 – 11]. An exergy balance can be formulated for every manufacturing system as follows:

$$B_{in} + B_{W,in} + B_{Q,in} = B_{out} + B_{W,out} + B_{Q,out} + B_{loss} \quad \text{Eq. 3}$$

The exergy of the aggregated materials entering and leaving the system are represented by  $B_{in/out}$ . The components  $B_{W,in/out} = W_{in/out}$  and  $B_{Q,in/out} = \left(1 - \frac{T_0}{T}\right) Q_{in/out}$  show the exergy flows accompanied with work and heat, respectively. Any work required beyond the minimum requirements is lost and expressed by  $B_{loss}$ . For this analysis, all exergies  $B$  are calculated in respect to the reference state  $T_0 = 298.15$  K and  $p_0 = 101.3$  kPa.

The first step in any system analysis is to identify the system boundaries. Depending on the enclosed control volume, results may differ substantially [9]. Here, we investigate this process for two different control volumes.

### 4.1 Control Volume: Forming Machine

The control volume of the first analysis is depicted in Fig. 4.

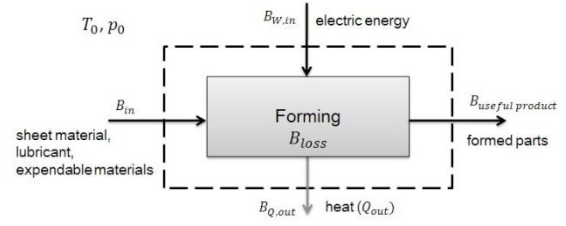

Fig. 4 Control volume: forming machine

Based on Eq.3 an efficiency measure termed *degree of perfection* can be established [11]:

$$\eta_p = \frac{B_{useful products}}{B_{in} + B_{W,in} + B_{Q,in}} = 1 - \frac{B_{loss}}{B_{in} + B_{W,in} + B_{Q,in}} \quad \text{Eq. 4}$$

Since the degree of perfection considers all material streams, it is possible to compare incremental forming to other forming technologies like hydroforming or conventional forming, now.

Forming processes are irreversible and most of the mechanical work applied for deformation is converted into thermal energy [12a]. Similar to subtractive processes, forming does not significantly alter the exergy of the material output compared to its inputs. As a result, the exergy of the sheet material entering the process equals approximately the exergy of the formed part. Using standard exergy tables [11], the exergy of the used aluminum and steel sheets ( $B_{useful product}$ ) can be estimated as 43 MJ/part and 27 MJ/part, respectively.

The electric energy consumption of conventional forming varies from 350 kJ/part to 800 kJ/part [6b]. In the following, we will assume an average energy consumption of 575 kJ/part. Typical hydroforming machine capacities range between 140 kW and 300 kW. Cycle times vary from 15 s up to 45 s [14]. Since the sample parts have a moderate depth and are relatively small, a medium sized press (250 kW) and cycle times of 15 s are assumed, which results in an electric energy consumption of 3.8 MJ/part.

The term  $B_{in}$  includes the exergy of the sheet material input, the lubricant and any expandable material.

Lubricants for sheet metal forming are mostly based on oleic acids [6c, 15]. Since the remaining components of a lubricant, which are additives to improve specific properties, can vary, it is presumed that the lubricant used in this study consists of oleic acid only. The exergy of oleic acid can be calculated as 41 MJ/kg. Approximately 65 g of lubricant are applied per part in the experiment. In case of DSIF both sides of the sheet are greased. Thus, the exergy

of the lubricant entering the process can be estimated as 2.7 MJ/part for SSIF and 5.3 MJ/part for DSIF, respectively. Experiments carried out by Rao [16] showed that 22.5 – 25.4 g/m lubricant were required to ensure a stable production in conventional deep drawing of aluminum alloys. So, the exergy embodied in the lubricant ranges from 0.45 to 0.51 MJ/part. In this study, it is assumed that sheet hydroforming requires the same amount of lubricant as conventional forming.

Some explanation is needed about including the exergy of the die sets for conventional forming and hydroforming, which is usually amortized over many parts in mass production. However, we investigate small batches in this analysis. Consequently, the exergy contribution of the required die sets must be considered as part of the expendable materials. Typical materials for prototyping die sets are cast iron and several plastics [6a, 12b, 17]. Here we ignore the contribution of possible fillers and use only the exergy values of the plastics. The exergy of cast iron and plastics (like epoxies) can be estimated as 8.2 MJ/kg and 33 MJ/kg, respectively. In this study, the die size depends only on the part dimensions. In reality, die set dimensions are also influenced by several machine tool parameters, like stroke length or working area. Additionally, it is presumed that the decision about the die set material does not affect the die set dimensions. Due to similar dimensions and forming loads for the sample parts, it is supposed that the required die set material is the same for all three parts.

Table 2 Required die set material and accompanying exergy

Required Material [cm ]	120670
Required Gray Cast Iron [kg] (Density 7.8 g/cm )	941
Exergy Cast Iron Die Set ( $B_{die\ set}^0$ ) [MJ]	7716
Required Plastic [kg] (Density 1.21 g/cm )	146
Exergy Plastic Die Set ( $B_{die\ set}^0$ ) [MJ]	4818

Since hydroforming requires just one half of the die set, the required plastic and the accompanied exergy of dies for sheet hydroforming are approximated as 50% of the values for conventional forming.

In general, die sets cannot be used after a certain amount of parts produced, but it is also possible that the number of produced parts is smaller than the actual lifespan. In this case, the die sets are scrapped, even though more parts could be formed. The lifespan of plastic dies is limited to low piece numbers, whereas cast iron dies can have series capabilities [6a]. In the following the lifespan of plastic die sets is set to 200 parts. The dies are replaced by new ones after the lifespan is reached. A critical point is the definition of the destroyed exergy. It could be argued that the exergy of scrapped die sets is lost. However, especially cast iron

die sets can be recycled very easily and are therefore a useful resource. According to Ashby [19a, b], cast iron and plastic have typically recycling rates of 80% and 0%, respectively. So, the net contribution of input exergy per part from die sets can be calculated as follows:

$$\Delta B_{die\ set} = \frac{B_{die\ set} \cdot (1 - \text{recycling rate})}{\text{produced parts}} \quad \text{Eq. 5}$$

Remaining expendable materials, like tooling for incremental forming or hydraulic oil losses, have very small exergies per part and can be ignored. According to Dahmus et al. [13], the environmental impact of the machine tool construction is amortized over numerous products and many years. Thus, the exergy contribution per part is negligible. Fig. 5 shows the sum of all exergy inputs over the number of produced aluminum samples. The calculations show that the exergy input of incremental forming methods is significantly lower than the exergy input of conventional forming or hydroforming in case of very small production runs. Conventional forming with cast iron die sets becomes advantageous as soon as more than 250 parts are produced. Although hydroforming requires just one half of the plastic die set, its exergy input is higher than the one of conventional forming with cast iron die sets.

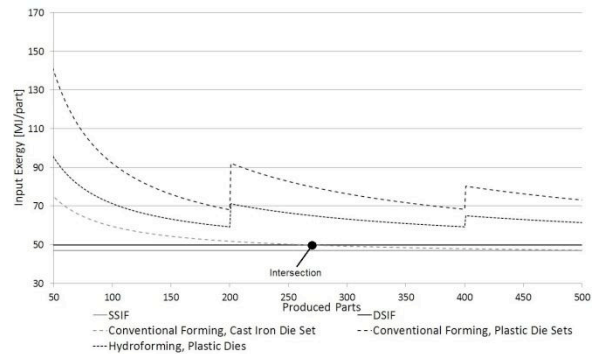

Fig. 5 Exergy inputs over the number of produced aluminum parts; control volume: forming machine

In order to understand which inputs are responsible for the exergy entering the system, it is useful to break the exergy inputs down. Fig. 6 presents the fractions of average exergy inputs for the sample parts formed by different technologies. The production run is set to 200 parts. In case of SSIF and DSIF the exergy entering the system accompanying the lubricant accounts for a higher contribution than the electric energy. Thus, the exergy of lubricants is not negligible. One can observe that the exergy accompanying the die set contributes a significant fraction of the exergy input in case of conventional forming and hydroforming. It becomes also clear that the exergy of the sheet material dominates the exergy inputs of the forming processes.

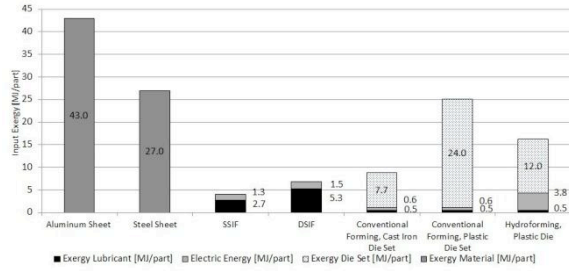

Fig. 6 Comparison of exergy inputs for different forming technologies; batch size: 200 parts; control volume: forming machine

Using the degree of perfection (Eq. 4), the efficiencies of SSIF and DSIF for forming the aluminum parts can be calculated as 91% and 86% respectively. The efficiencies of conventional forming and hydroforming depend, as well as the exergy input on the number of produced parts. In case of a production run of 200 parts conventional forming with cast iron die sets and plastic die sets has an efficiency of 83% and 63%, respectively. The efficiency of hydroforming can be calculated as 73% for this example.

The calculation of efficiencies with the degree of perfection gives an interesting insight. The efficiency of SSIF and DSIF forming the steel samples decreases to 89% and 86%, respectively, although the electricity input stays almost constant and the mechanical work at the tool roughly doubles. This result shows that the degree of perfection depends strongly on the exergy of the sheet material.

#### 4.2 Control Volume: Supply Chain

To this point, the analysis has been limited to material and energy streams that are connected directly to the forming

process, but in order to understand and evaluate the impact of the different technologies on the environment entirely, it is necessary to expand the control volume. The new boundaries encompass the entire supply chain including material processing systems (aluminum production and die set manufacturing) and power supplying systems (power plants and coking). Since nearly all input materials are primary energy resources, the results of this analysis are comparable to the results of a general embodied energy analysis (see [18b]). Due to the high complexity of system modeling, the second analysis is limited to forming of aluminum samples. Exemplary, the supply chain for conventional forming with cast iron die sets is depicted in Fig. 7. The gray shaded inputs and outputs are neglected in this analysis.

The following exergy analysis of aluminum sheet forming is carried out with a newly developed Simulink blockset. The data for the modeled subsystems can be found in [11, 13, 18 – 32]

Fig. 8 gives a graphical representation of the exergy inputs over the number of produced parts. In contrast to the previous exergy analysis, this analysis suggests that a break-even between conventional forming or hydroforming and AISF is not reached within typical prototyping batch sizes. The analysis of the new control volume causes hydroforming to be advantageous compared to conventional forming with cast iron die sets for production runs up to 200 parts. This result emphasizes the importance of a holistic analysis in order to estimate the true impact of different technologies.

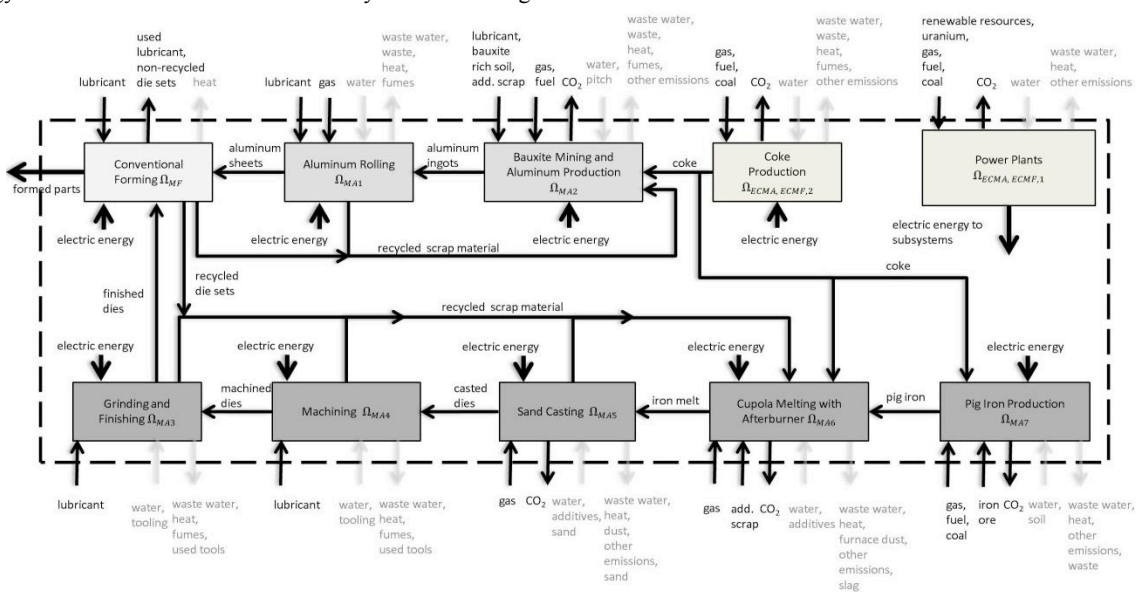

Fig. 7 Control volume of the supply chain for formed aluminum parts with a conventional press and cast iron die sets

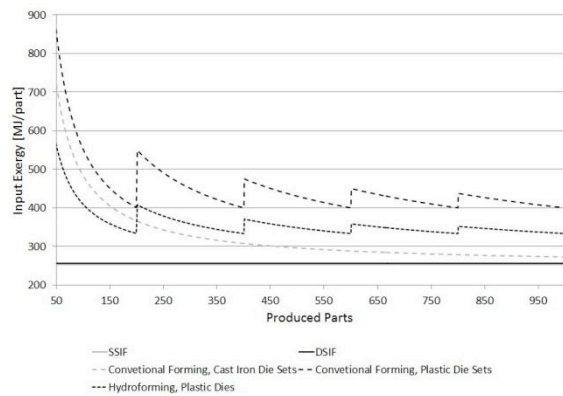

Fig. 8 Comparison of forming related exergy inputs (without aluminum production); control volume: supply chain

Compared to the calculated values in the preceding analysis the exergy input increases for all technologies. This has two reasons, which are closely related to inefficiencies of upstream activities. First, the electric power supply has an assumed efficiency of about 39.1%. Second, the upstream energy intensive activities for material processing systems are included. Particularly, cast iron and plastic production are two very energy intense production processes.

An exergy breakdown (Fig. 9) clarifies that the exergy input related to the aluminum production dominates the total exergy entering the system. In case of ISF it accounts for 96 – 98% of the input exergy. The different fractions of fuel and non-fuel inputs for cast iron and plastic die sets derive from different starting positions of the supply chain models. While the production of cast iron die sets is modeled from cradle to gate, the modeled plastic die set production uses already some basic materials, like benzene or n-heptane. These basic materials have a higher chemical exergy than iron ore. So, the non-fuel exergy input of the die set production is bigger for plastic die sets.

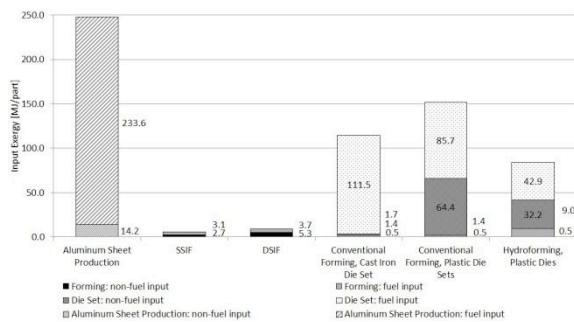

Fig. 9 Comparison of exergy inputs for different forming technologies; batch size: 200 parts; control volume: supply chain

The efficiency of the supply chain is calculated with the degree of perfection (Eq. 4). The efficiencies of SSIF and DSIF are 17%. In case of a 200 part production run conventional forming and hydroforming have efficiencies of 11 – 12% and 13%, respectively. Responsible for the different efficiencies are mainly the exergy inputs required for the die set production. It becomes clear that the use of ISF enhances the efficiency of the entire supply chain for typical prototyping batch sizes.

So far, only the efficiencies of forming processes producing the sample parts have been compared. In reality many prototyping parts are more complex, have more geometrical features or higher surface quality requirements, which causes, in case of incremental forming, a much longer forming time. Aiming to investigate how the results are affected by a longer processing time, a sensitivity analysis is carried out. The details can be found in [33]. The analysis suggests that DSIF is advantageous for prototyping and producing very small batch sizes, like 300 parts or less, from an exergetic point of view.

## 5 CO<sub>2</sub> Emissions

The developed blockset can also be used to estimate CO<sub>2</sub> emissions of the supply chain. The simulation shows that CO<sub>2</sub> emissions from the electricity production for DSIF (0.2 – 0.3 kg CO<sub>2</sub>/part) are not meaningfully higher than for SSIF (0.2 kg CO<sub>2</sub>/part). The CO<sub>2</sub> emissions of the ISF supply chain are dominated by the emissions of the aluminum production (15.9 kg CO<sub>2</sub>/part).

The emissions resulting from the die set production are calculated as 1578 – 1848 kg CO<sub>2</sub> per cast iron die sets and 1102 – 1305 kg CO<sub>2</sub> per plastic die set.

It can be seen that significant CO<sub>2</sub> reductions are possible by shifting from conventional to incremental forming in case of small production runs.

## 6 Conclusion and Outlook

Using the concept of exergy two analyses with different control volumes were carried out aiming to compare incremental forming, conventional forming and hydroforming technologies in case of small production runs. The first exergy analysis showed that the exergy of the material input dominated the electricity input. Particularly, the exergy of the sheet material contributed a significant fraction to the total exergy input. Consequently, the degree of perfection resulted in relatively high values. Moreover, it became clear that different sheet materials can cause varying efficiency results, when the degree of perfection is used as an efficiency measure. An additional finding was that the exergy of the lubricant accounted, in case of

incremental forming, for a higher fraction of the total exergy input than electricity.

A second control volume was analyzed aiming to investigate the impact of different forming technologies from a supply chain perspective. Since the input materials were mostly primary fuels, the analysis was comparable to a general embodied energy analysis.

Although the results may vary with different assumptions, this study indicates that ISF is advantageous for prototyping and small production runs up to 300 parts from an environmental perspective. However, both analyses reveal that several areas of potential improvements exist. The use of less lubricant as well as the reduction of electricity consumption for idle running would result in a higher efficiency. Developments towards a shorter forming time, like improved tool path or enhanced tooltip movability, can also reduce the electricity input.

## 7 Acknowledgements

The authors gratefully acknowledge the support of the U.S. Department of Energy, Award DE-EE0003460, technical contact Dr. Debo Archbhaumik.

## References

- [1] Attanasio, A.; Ceretti, E.; Giardini, C.; Mazzone, L.: *Asymmetric two points incremental forming: Improving surface quality and geometric accuracy by tool path optimization*, Journal of Material Processing Technology 197, 2008, pp. 59 – 67
- [2] Heinz, A.; Haszler, A.; Keidel, C.; Moldenhauer, S.; Benedictus, R.; Miller, W.S.: *Recent development in aluminum alloys for aerospace applications*, Mater. Sci. Eng. A280, 2000, pp. 102 – 107
- [3] Jeswiet, J.; Micari, F.; Hirt, G.; Bramley, A.; Dufloy, J.; Allwood, J.: *Asymmetric Single Point Incremental Forming of Sheet Metal*, CIRP Annals – Manufacturing Technology Volume 54, Issue 2, 2005, pp. 88 – 114
- [4] Cao, J.; Reddy, N.V.: *Incremental Sheet Metal Forming: A Review*, Proceedings of Indo-US workshop on Smart Machine Tools, December, 2008
- [5] Park, J.J.; Kim, Y.H.: *Fundamental studies on the incremental sheet metal forming technique*, Journal of Materials Processing Technology 140, 2003, pp. 447 – 453
- [6] Schuler GmbH: *Metal Forming Handbook*, Springer Verlag, 1998 a) pp. 137 – 139 b) p. 200 c) p. 184

- [7] Allwood, J.M.; King, G.P.F.; Dufloy, J.: *A structured search for applications of the incremental sheet-forming process by product segmentation*, Proc. IMechE Vol. 219 B, 2004, pp. 239 – 244
- [8] Gyftopoulos, E.P.; Beretta, B.P.: *Thermodynamics: Foundations and Applications*, Dover Publications, Inc., 2005, a) pp. 400 – 414, b) p. 606
- [9] Gutowski, T.G.; Branham, M.; Dahmus, J.B.; Jones, A.; Thierez, A.; Sekulic, D.P.: *Thermodynamic Analysis of Resources Used in Manufacturing Processes*, Environ. Sci. Technol., 2009, pp. 1584 – 1590
- [10] Branham, M.; Gutowski, T.G.; Jones, A.; Sekulic, D.P.: *A Thermodynamic Framework for Analyzing and Improving Manufacturing Processes*, IEEE International Symposium on Electronics and the Environment, May 19 – 20, 2008
- [11] Szargut, J.; Morris, D.R.; Steward, F.R.: *Exergy Analysis of Thermal, Chemical and Metallurgical Processes*, Hemisphere Publishing Corporation, 1988
- [12] Lange K.: *Handbook of Metal Forming*, McGraw-Hill Book Company, 1985
- [13] Dahmus, J.B.; Gutowski, T.G.: *An Environmental Analysis of Machining*, Proceedings of IMECE2004, ASME International Mechanical Engineering Congress and RD&D Expo, November 13 – 19, 2004, Anaheim, California USA
- [14] Matwick, S.E.: *An Economic Evaluation of Sheet Hydroforming and Low Volume Stamping and the Effects of Manufacturing Systems Analysis*, Master of Science in Engineering Thesis, Massachusetts Institute of Technology, Cambridge, MA., February 2003
- [15] Nachtman E.S.; Kalpakjian, S.: *Lubricants and Lubrication in metalworking Operations*, Marcel Dekker Inc., 1985, pp. 223 – 247
- [16] Rao, K.P.; Wei, J.J.: *Performance of a new dry lubricant in forming of aluminum alloy sheets*, Wear 249, 2001, pp. 86 – 93
- [17] Tschaetsch, H.: *Metal Forming Practice – Processes, Machines, Tools*, Springer Verlag, 2006, pp. 158 – 169
- [18] Ashby M.F.: *Materials and the Environment, Eco-Informed Material Choice*, Elsevier Inc., 2009 a) p.302 b) pp. 290 – 291
- [19] Smil, V.: *Energy in Nature and Society – General Energetics of Complex Systems*, The MIT Press, 2008
- [20] Baniszewski, B.: *An Environmental Impact Analysis of Grinding*, Bachelor of Science in Mechanical Engineering at the Massachusetts Institute of Technology, June 2005



- [21] Buzoverya, M.T.; Yankovskii, A.S.; Budnik L.G.; Laptsev, A.; Maryasov, M.F.: *Analysis of Expenditures on Heat and Energy Resources in Pig-Iron Production*, Metallurgist Volume 29, Number 12, pp. 378 – 379, DOI: 10.1007/BF0074290
- [22] Capman, P. F.; Leach, G. and Slesser, M.: *The energy costs of fuels*, Energy Policy, 1974, pp. 231 – 243
- [23] Green, J.A.S.: *Aluminum Recycling and Processing for Energy Conversion and Sustainability*, ASM International, 2007
- [24] Hammond, G.; Jones, C.: *Inventory of Carbon & Energy, Version 1.6a*, University of Bath, UK, available from: [www.bath.ac.uk/mech-eng/sert/embodied/](http://www.bath.ac.uk/mech-eng/sert/embodied/). Accessed 23 January 2011
- [25] Jones, A: *The Industrial Ecology of the Iron Casting Industry*, Master of Science in Engineering Thesis, Massachusetts Institute of Technology, Cambridge, MA., May 2007
- [26] Koc, M.: *Hydroforming for advanced manufacturing*, CRC Press, 2008
- [27] Thiriez, A: *An Environmental Analysis of Injection Molding*, Master of Science in Mechanical Engineering at the Massachusetts Institute of Technology, May 2006
- [28] Wall, G.: *Exergy Conversion in the Swedish Society*, Resources and Energy 9, 1986, pp. 55 – 73
- [29] Wall, G.: *Exergy Conversion in the Japanese Society*, Energy Vol. 15, No. 5, 1990, pp. 435 – 444
- [30] Worell, E.; Martin, N. and Price, L: *Energy Efficiency and Carbon Dioxide Emissions Reduction Opportunities in the U.S. Iron and Steel Sector*, Environmental Energy Technologies Division, 1999
- [31] Valero, A.; Valero, A; *Exergoecology: A thermodynamic approach for accounting the Earth's mineral capital. The case of bauxite-aluminum and limestone-lime chains*, Energy 35, 2010, pp. 229 – 238
- [32] Schubert, P.B.: *Die Methods, Design, Fabrication, Maintenance and Application*, Industrial Press Inc. 1966, pp. 383 – 390
- [33] Dittrich, M.A.: *Exergy Analysis of Sheet Metal Prototyping Technologies*, research report, Leibniz University Hannover, 2011