



Room 14-0551
77 Massachusetts Avenue
Cambridge, MA 02139
Ph: 617.253.2800
Email: docs@mit.edu
<http://libraries.mit.edu/docs>

DISCLAIMER OF QUALITY

Due to the condition of the original material, there are unavoidable flaws in this reproduction. We have made every effort possible to provide you with the best copy available. If you are dissatisfied with this product and find it unusable, please contact Document Services as soon as possible.

Thank you.

The images contained in this document are of the best quality available.

CONTENTS

Abstract

	page
CHAPTER 1 EXPEDITION	1
CHAPTER 2 ECOLOGICAL CHARACTERISTICS	
2.1 - Wind	10
2.2 - Slope	15
2.3 - Soil	19
2.4 - Geology	23
2.5 - Vegetation	26
2.6 - Rainfall	31
2.7 - Runoff	34
2.8 - Grade	38
2.9 - Temperature	40
2.10 - Humidity	44
2.11 - Evaporation	45
2.12 - Archaeology	47
CHAPTER 3 SETTLEMENT PLANNING	
3.1 - Buildable Land	53
3.2 - Arable Land	70
3.3 - Settlement Size	89
3.4 - Orientation	91
3.5 - Form of a Settlement	91
3.6 - Building Height	95
3.7 - Distance between Buildings	97
3.8 - Power	99
3.9 - Organic Waste Treatment	103
3.10 - Building Materials	105
3.11 - The Roof	110
3.12 - Closure	115
CHAPTER 4 BUILT PRECEDENT	
4.1 - Cave	123
4.2 - Mountain	125
4.3 - Hill	131
4.4 - Mesa	137
4.5 - Canyon	141
4.6 - Plain	148
4.7 - Precedent Summary	163

	page
CHAPTER 5 TWIN COVE	169
BIBLIOGRAPHY	182
LIST OF ILLUSTRATIONS	187

Abstract

Building an Equilibrium with the Desert

David Craig Rogers

Submitted to the Department of Architecture on May 12, 1978 in partial fulfillment of the requirements for the degree of Master of Architecture.

A fundamental reference for building design is the land on which we build. A thorough understanding of the land is a study in ecological planning. The reference is not an aesthetic of relating built form to nature but it is the equilibrium of natural forces.

The more extreme the climate or the more limiting the conditions then the more fragile or vulnerable is the entire ecosystem to disturbance. This is precisely the problem involved with building for man's needs in the drier regions of the Southwest.

The purpose of this thesis is to examine the range of ecological characteristics of this region as a basis for guiding the design of built environments. The ecological characteristics include a categorized range of site conditions found in a designated area of south central Arizona.

This information is translated into settlement design decisions through a process of mapping, text and illustrations. Since settlements have existed and thrived for thousands of years in desert lands similar to this region, a survey of these same design decisions is conducted over a range of topographic sites.

In conclusion a settlement is designed on a site identified as most appropriate for building and cultivation with a partial understanding of this desert and the precedent of millennia.

Thesis Supervisor: _____

Maurice Smith
Professor of Architecture

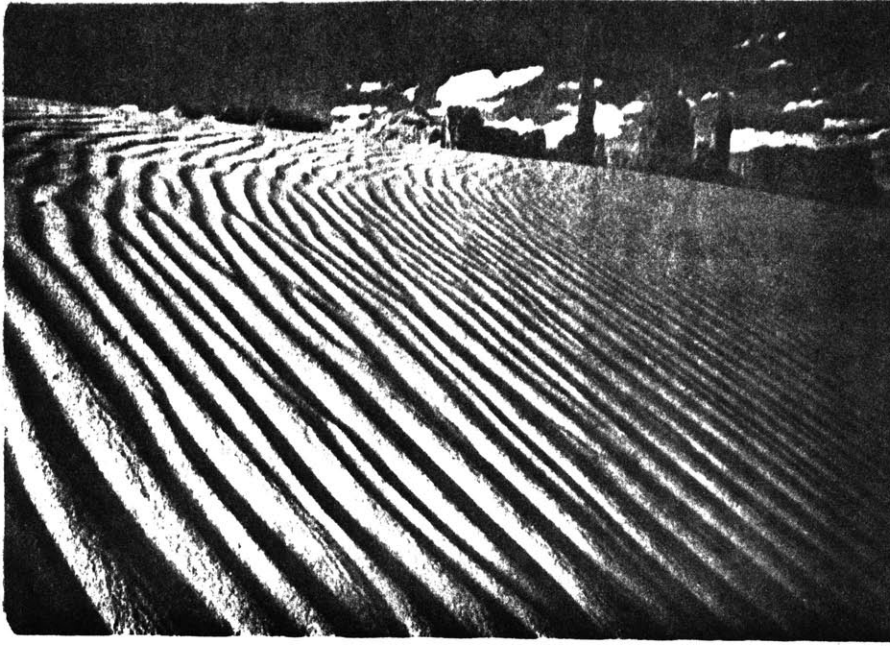

Emerging from our canvas shroud, dust billows from the upper canopy into the cool motionless air of the morning. The silence is breathless. The dark disintegrates before and above us as streams of color streak across a few wisps of cloud in the deep everpresent blue. The morning air is cool in this valley plain. Gentle downslope night winds have pooled cool air from the mountain slopes into the valley. In the dim light our tents blend into the landscape as an extension of a few small mesquite or remnants of last evening's shadow.

This desert is not a windswept barren dune of sand, Rather it is like eighty percent of desert areas on the earth, a desert of adequately armed and defensible plants among stone, gravel, sand and shallow soil. Rarely is there a place especially here, north of Phoenix, where the horizon is not ringed with peaks. The desert floor is fill or alluvium washed down from many mountains' mass forming a hard packed sandy clay for at least 100 feet below the surface.

The landscape like the morning is streaked with concentrated color of flourishing growth along arroyos amidst the evenly separate or clustered creosote bush, cacti and grass. This morning at the foot of our climb we have stopped to study a few for each is an unique balance of conditions from the specifics of climate to the stone surrounding it. Sites appear to be chosen where the soil is most suitable, the roots stretched in all directions to lay claim to the watershed of the surrounding ground. Most have succulent stems which store water from their last unpredictable ration. Leaves are vestigial or completely absent because too much water would evaporate from them. The stems are green with chlorophyll to perform the function of leaves and are often coated with wax. Above, intricate screens cover the entire stem. Screens which are strong and singular emphasize their protective function from animals only too glad to use their

succulence. Screens thin and often dense separate the stem from the hot dissicating air by thick mats of needles providing direct shade to the stem's surface. We resume our ascent up the progressively steeper and stone strewn terrain.

As we near the edge of a ridge a silhouette of a saguaro raises its arms in the fiery glow of dawn. First there is one then a dozen saguaros appear with green trunked paloverde spread out between. The slope has not changed appreciably, certainly not the altitude and yet these saguaros, giant sentinels towering forty feet over us and weighing up to six tons surround us. Yet they are obviously, in

BARREL CACTUS

Longitudinal Section

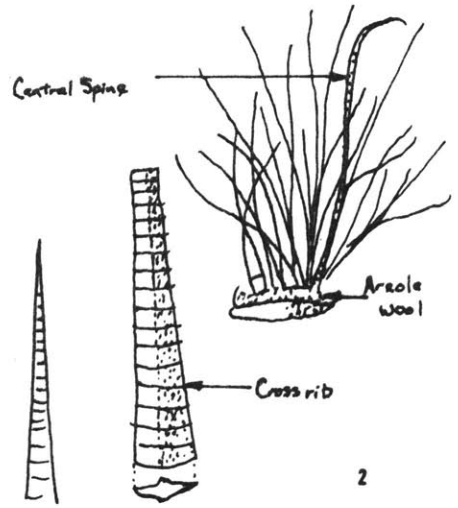
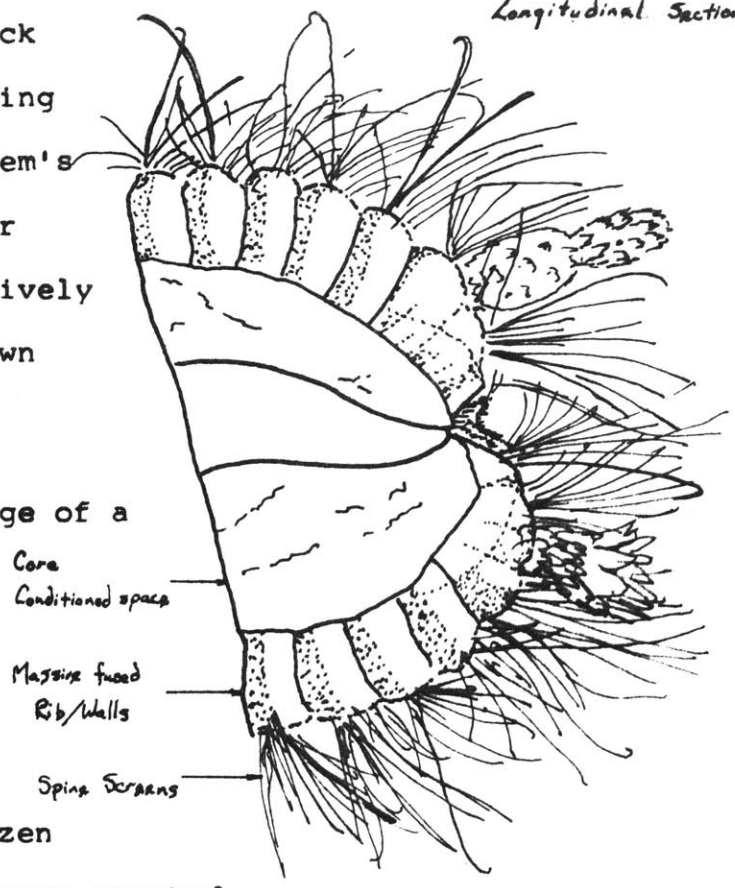

everything except size, quite like most other cacti. The waxy green skin is tender covered by pads of thick needles. It is the ground under our feet which offers the first clue. Though the gravel and stones may look even less hospitable than the sandy clay, rain that falls here soaks into the ground, rather than immediately off it. From the towering height of the saguaro we might expect long roots penetrating many times its height into the ground. But water on this gravel seldom penetrates deep into the parched surface. With a slight slope the water penetrates only eight to twenty inches, appropriately the depths of the saguaro's roots. Shallow as they are, they are deep enough to prevent evaporation and extend up to ninety feet in radius. Correspondingly with their basic understanding of water flow their roots on a slope are predominantly perpendicular to the slope. The saguaro's water system is then fully able to take advantage of the torrential downpours when these roots are bathed in water. A full ton of water may be taken up after a single storm, the accordion-like pleats of the trunk unfolding as water is absorbed. Carefully in his cistern, the saguaro can easily manage through many months of drought. His astounding height is not achieved by layering but rather by rigid verticle reinforcement within a flexible mass. The reinforcement, long circular wood rods joined in a cylinder by a wooden fabric are as long as the saguaro is tall and are as ~~imm~~ immune to decay as cypress. As expected, his strength and

superiority does not go unnoticed. A saguaro often acquires numerous small caves first excavated by a woodpecker and then abandoned. I would presume the initial advantage is the cooling effect of the moist mass within the hole for the woodpecker before the saguaro heals the wound into a complete pocket of hard scar tissue. These abandoned dwellings become favorite sites for wrens, elf owls and numerous other birds, dark and sheltered from the sun and heat by the trunks' mass. Truly the saguaro is an instructive teacher of balance in the desert.

As our path steepens we follow for a moment a dry arroyo lined with cottonwood. Away from its edge and up slope we find ocotillo waving their red tipped fronds in the wind. Here at 4500' the saguaros stop as abruptly as they began. The air becomes cooler now because of altitude, a rise of a thousand feet verticle being approxiamately equal to travelling six hundred miles north. The characteristic tree is now the evergreen oak with yucca and agave in clusters along the ground.

Glancing down and over the slopes beneath us a question occurs to me. Why has no one ever built here? In fact not just here for between the highlands of Prescott and the valley plain of Phoenix very little human activity occurs. Why is that true? The air is cooler here. The rain falls more often here than in the valley. Compared to the valley vegetation thrives. Besides the views over canyons, up mountain slopes,

out and across valleys are incredible. Is it just because of the ease with which development occurs over flat land rather than on these slopes? Yet, there must be something more basic ~~which~~ will not allow the throngs of Phoenicians to extend themselves to this place.

Our chosen climb rises now before us, long slabs of granite broken ever so discreetly by the cracks which will allow a route up. Fifteen hundred feet above us we can just see the outline of Arizona pine, rising at least one hundred feet to cast thick deep shadows onto a needle carpet floor. We sit down on a pile of stones to study possible routes. We discuss the advantage of taking the first pitch along a ridge rather than in an adjacent crevasse. I am studying the pile of stones we just sat on. For it is not just any pile but a long row of piled stones. We have decided on a route. Maybe it is the remains of an old stone border wall to someone's property. We resume walking up the slope to the base of our climb. Then there is another row of stones and another not high but quite the same as the first and perpendicular to the slope. Maybe someone has built here.

Halfway up the cliff I pause to study a yellow patch of lichen glistening in the sunlight. The lichen seems so insignificant yet it flourishes here on this precipice. Requiring only a hint of moisture the rootless plant tenaciously hangs on to smooth granite as nothing else can,

eventually providing the sustenance for the next larger plant. The remains of these plants washed away with the gravel and sand of broken granite become the humus of the soil, the all important ingredient to allow larger plants and food to be grown. Turning out to the distance, I notice the way two parallel arroyos branch to form interlocking fingers of cottonwoods with the 'line' of saguaros. The lazy spiral of a hawk drifting up past me intercepts my view.



We have joined the spiral in a Diamant. As we climb, banked into a comfortable thirty degree turn, paloverde trees and creosote bushes in the desert below us change from discrete plants to dots in assymetric patterns. We will be exploring a region of south central Arizona encompassing 4500 square kilometers. Soaring between thermals and updrafts we will begin to understand the movements of the winds, the pattern of air currents determined by the force and direction of the wind and the shape of the obstacles which it encounters. From varying heights of 1,000 to 10,000 feet AGL we will map the delicate topography, soil gradations, vegetation and dry drainage system tracteries.

Gaining speed and altitude, spiraling at 500 feet per minute, a geometrical transformation alters our perception of the land beneath us. The land is now a texture allowing a broad vision of the changes between the desert and highlands. Interlacing the transition lie gentle slopes, mesas, steep canyons, bajadas, plateaus and high peaks. To the south Lake Pleasant formed by the damming of the floodwaters of the Agua Fria and Calderwood Butte projecting just north of the valley plain of Phoenix. To the east the New River Mountains and Brooklyn Peaks rise high above the mesas and canyons between them. To the west lies the Bradshaw Hieroglyphic mountains where we may soar a lee wave up to five times the height of the summits above the adjacent valley. With the right wind our airfield is Cordes Junction, to the north.

5 Statute Miles

MAP 1 North Central Arizona

Topographic Scale 1:250,000

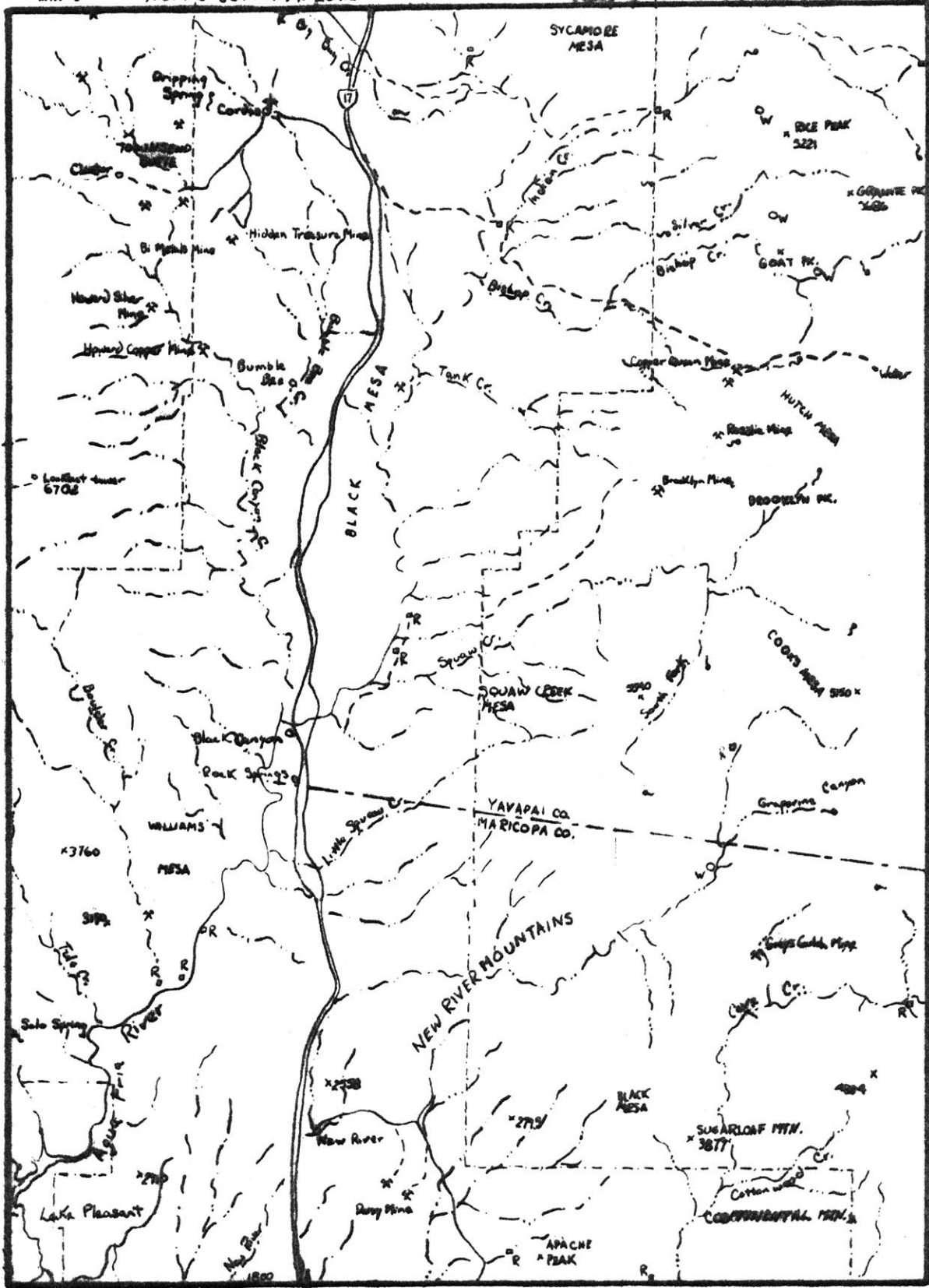

WIND 21

Wind data for Arizona is not especially abundant existing in quantity only for the U.S. Weather Services offices in Winslow, Flagstaff, Prescott, Tucson, Phoenix and Yuma. For this region a wind map has been drawn from experiences gained and related by soaring. The map indicates the following major wind regions:

- W - Westerly
- B - Bubble
- MV - Mountain/Valley winds
- MV & C - Mountain/Valley and Canyon winds

The occurrence of prevailing westerly winds at this latitude especially towards higher altitudes can be explained by the global coriolis effect. The natural rotation of the earth causes an apparent force to be exerted on the atmosphere which deflects the air towards the right in the northern hemisphere. At 30° north latitude there exists a permanent high pressure area due to the pile up of air caused by the deflection of air moving northward from the equator. Due to this high pressure area the air circulates clockwise around the high producing the prevailing westerlies. Old sailors knew of the latitudes between 20° and 35° as dangerous and unpredictable, of frequent calms and erratic winds. They named them the horse latitudes, analogous to the wild temperament of a young colt.

5 Statute Miles 0

Wind

MAP 2

KEY

- W - Westerly
- B - Bubble
- MV - Mountain-Valley winds
- C - Canyon winds

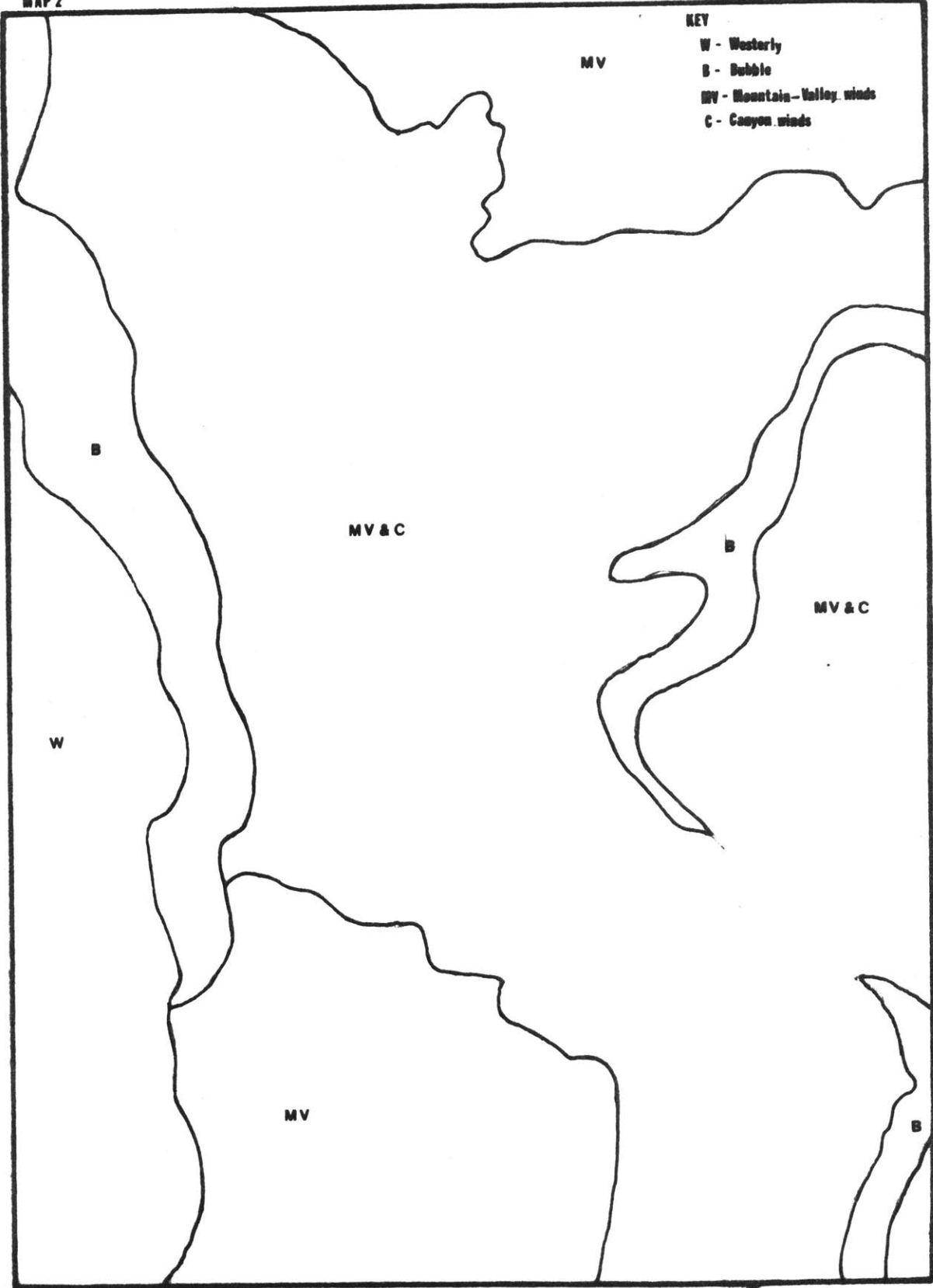

A Bubble or mountain wave is analogous to water running over a log in a river. First the water flows up over the log comparable to the ridge lift over a mountain range. Then it flows down making a trough, then up, and continuing in a diminishing succession of crests and troughs. These relatively stationary waves are similar to a mountain wave with accompanying updrafts and downdrafts as illustrated below.

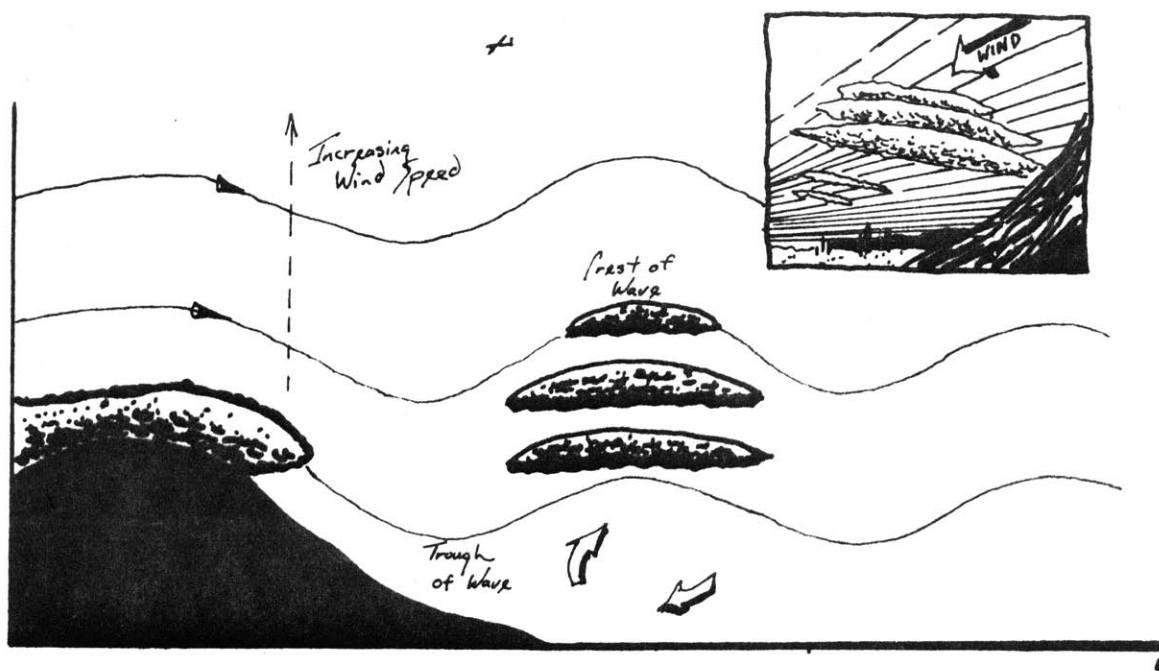

Prevailing winds can be expected to be East for summer and winter in the lowlands to the south in this region. For the mountains and mesas the prevailing directions should be to the southwest in the summer and to the southeast in the winter.

Mountain/Valley and Canyon winds can be distinguished by their relative scales of width. Wind direction is greatly

affected by differential heating of the slopes and valleys, high or low land. Usually if no large scale weather disturbances are present and the winds in the free atmosphere are light the surface wind will blow upslope during the day. At night downslope or downvalley winds are induced by the rapid radiational cooling of the air overlying the mountain slopes compared to the slow cooling of the air over the valley. Deep narrow canyons can be the windiest as they often increase wind speed by channelling. Normally daytime upslope winds are two to three times stronger than the night downslope winds. Due to the rugged and widely varying terrain of this region, stagnant winds for extended periods are unlikely.

A further characteristic of this region and of most deserts are sandstorms which are quite common in late winter and spring. At a wind speed of 12 mph, sand travels by bounding usually less than four feet off the ground.

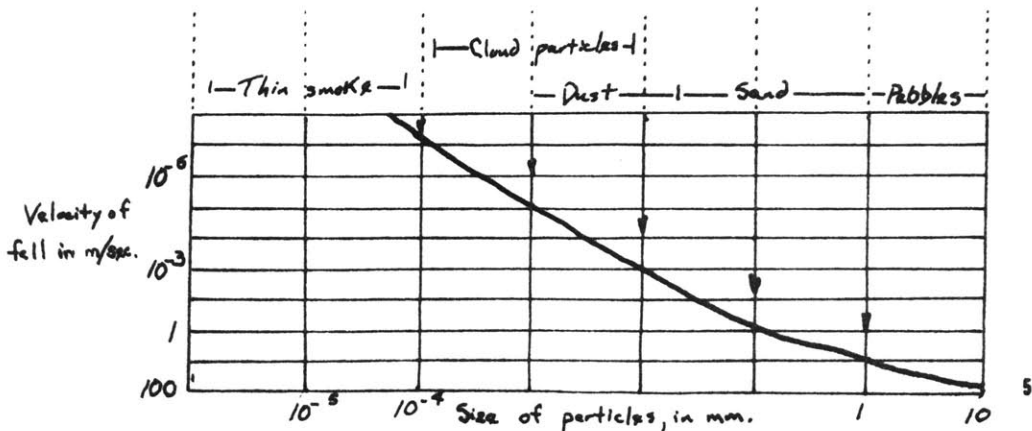

Although the prevailing wind directions offer the best clues for the hardest sandblasting in these storms often the fine luustrine, ancient lake, dust is so thick , visibility being less than arm's length that there is no direction from which the sand or dust does not enter.

SLOPE

The major incident energy domains are illustrated on map 3. The region was divided into 68 domains corresponding to one of eight compass points as the primary slope orientation. Corresponding to these orientations each slope will receive differing average amounts of solar insolation. The insolation will vary due to both the inclination of the slope as well as its orientation. Considering the two extremes of east and west slopes, the east slope will receive insolation from the sun when the temperature is coolest while the west slopes will receive the sun when the temperature is already warm. As evident from the following graphs the south orientations receive the most insolation from the sun in December, one of the underheated months. During the overheated periods, east and west orientations receive the most insolation. For 32°N latitude the insolation in btu/ft²/day:

	January 21st	June 21st
North	150	504
NW&NE	166	924
W&E	604	1152
SW&SE	1236	858
South	1668	444

Sol-air temperature is the temperature of the outside air plus the local heating caused by insolation on a surface. Using these temperatures and the insolation for varying orientations and a desired temperature range of 69° to 80°, approximately 63% of the year requires shade

MAP 3

Slope Orientations

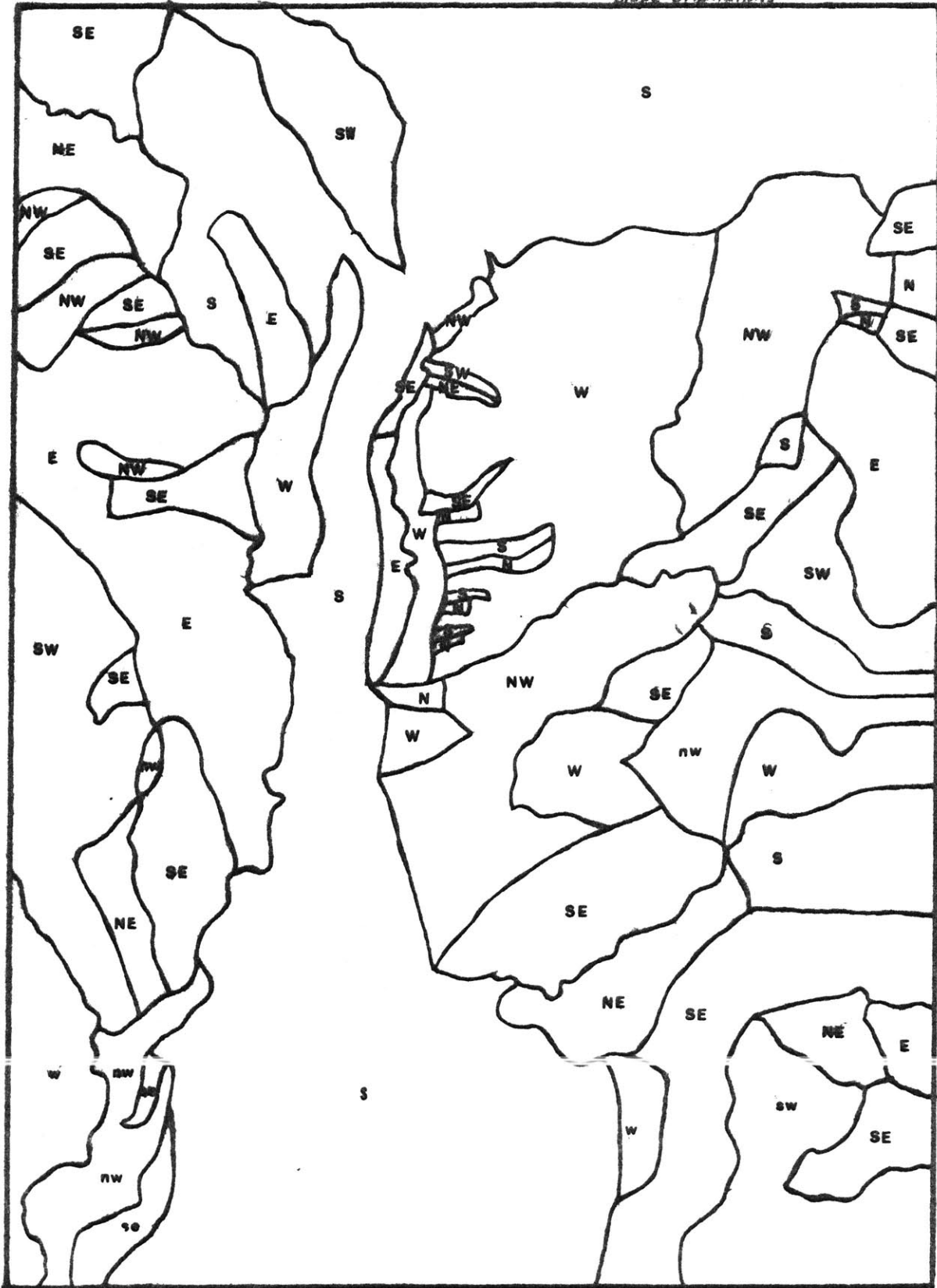

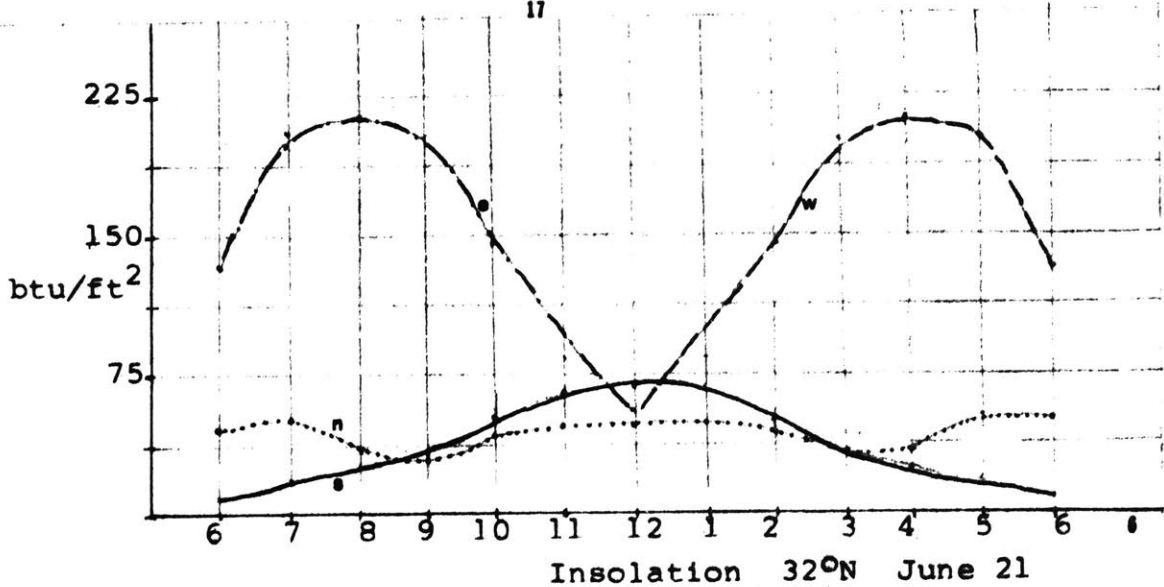

from insolation. The west and southwest orientations provide this insolation in the overheated months when temperatures are highest, while the east and southeast orientations provide insolation in the morning when it is coolest. A southeast orientation (25° East of South) provides the optimum orientation. Sites located above the transition zone, on the mesas or on the mountains would benefit from a slight southerly shift to 20° East of South.

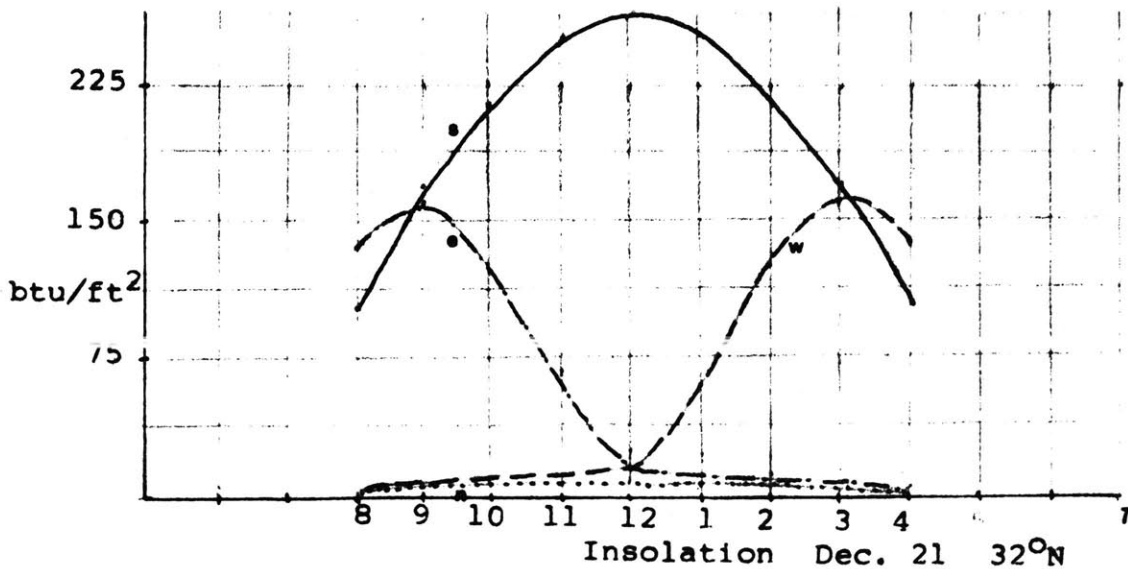

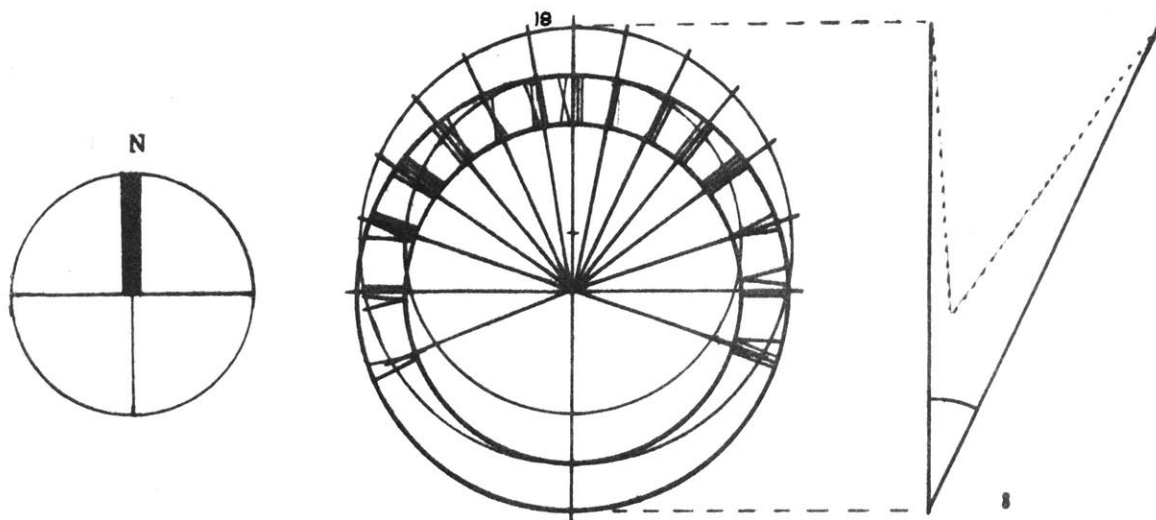

Sundial construction

The sky of the desert is usually cloudless and clear. At night it is a deep blue (600 to 650 ft.-lamberts). Sunrises and sunsets are spectacular and bright, 1,000 to 1,500 ft.-lamberts or more often more than twice the brightness of the sky in the temperate zones. This area receives an average of 80% of the possible sunlight as measured by smoothed isolines based on data from black bulb type sunshine recorders. Such a constant and dazzling presence is without equal in importance for understanding the balance of the desert. Perhaps the construction of a sundial is the first step.

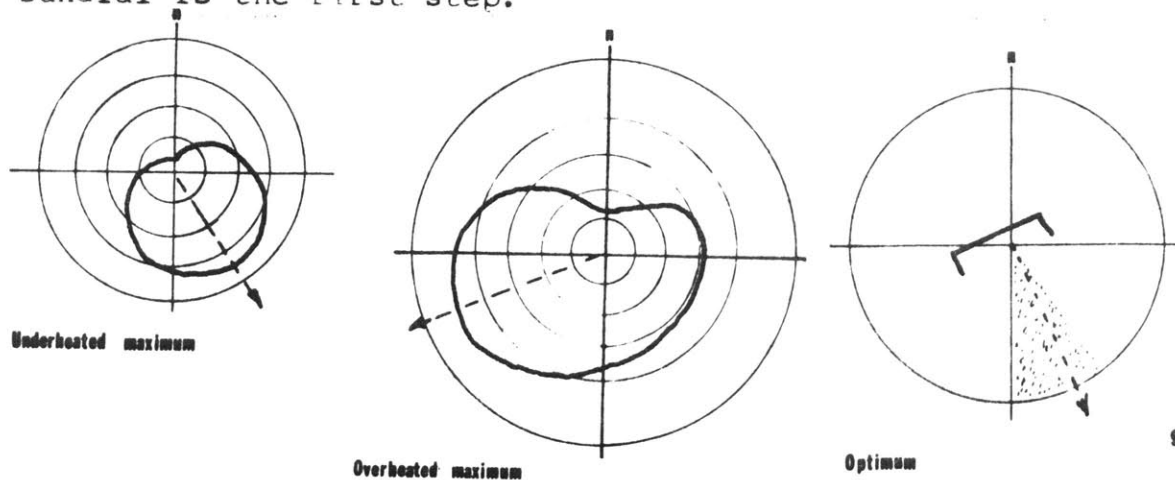

SOIL 2.3

Soil is formed by four major factors - climate, parent rock material, relief and vegetation. Under extreme arid condition one can expect to find soils only in isolated places. On the large scale this would be an oasis or on the small scale beneath an isolated bush. Those soils existing primarily on steep slopes or extended consolidated rock are called lithosols, where the bedrock is resistant to weathering and carries little to no vegetation.

In the less extreme arid lands of which this region is a part there is frequently an upward movement of soil moisture creating a leaching of soluble mineral salts such as calcium carbonate (CaCO_3) and calcium sulfate. These soils are known as pedocal illustrated in figure 10 . Often since this soil contains less than 1% organic matter, a hard caliche surface crust of lime and gypsum may appear. Both dry farming and irrigation of the soil are intended to reverse this leaching process allowing the mineral nutrients in the soil to become available in a form useable by vegetation.

Referring to the soil map, the following designations have been used:

- B - Basalt, igneous Grumsol from upland plains & mtns.
- G - Granite soil from mountains and foothills
- M - Mixed soil, primarily Reddish Brown
- DA - Alluvium from valley floors and side slopes,
Calcisol
- VA - Alluvium from valley plains and slopes, Red
Desert - Calcisol



Soil

MAP 4

KEY

- B - Basaltic, Grumusol
- G - Granitic
- M - Mixed
- DA - Valley floor Alluvium
- VA - Red Desert Alluvium

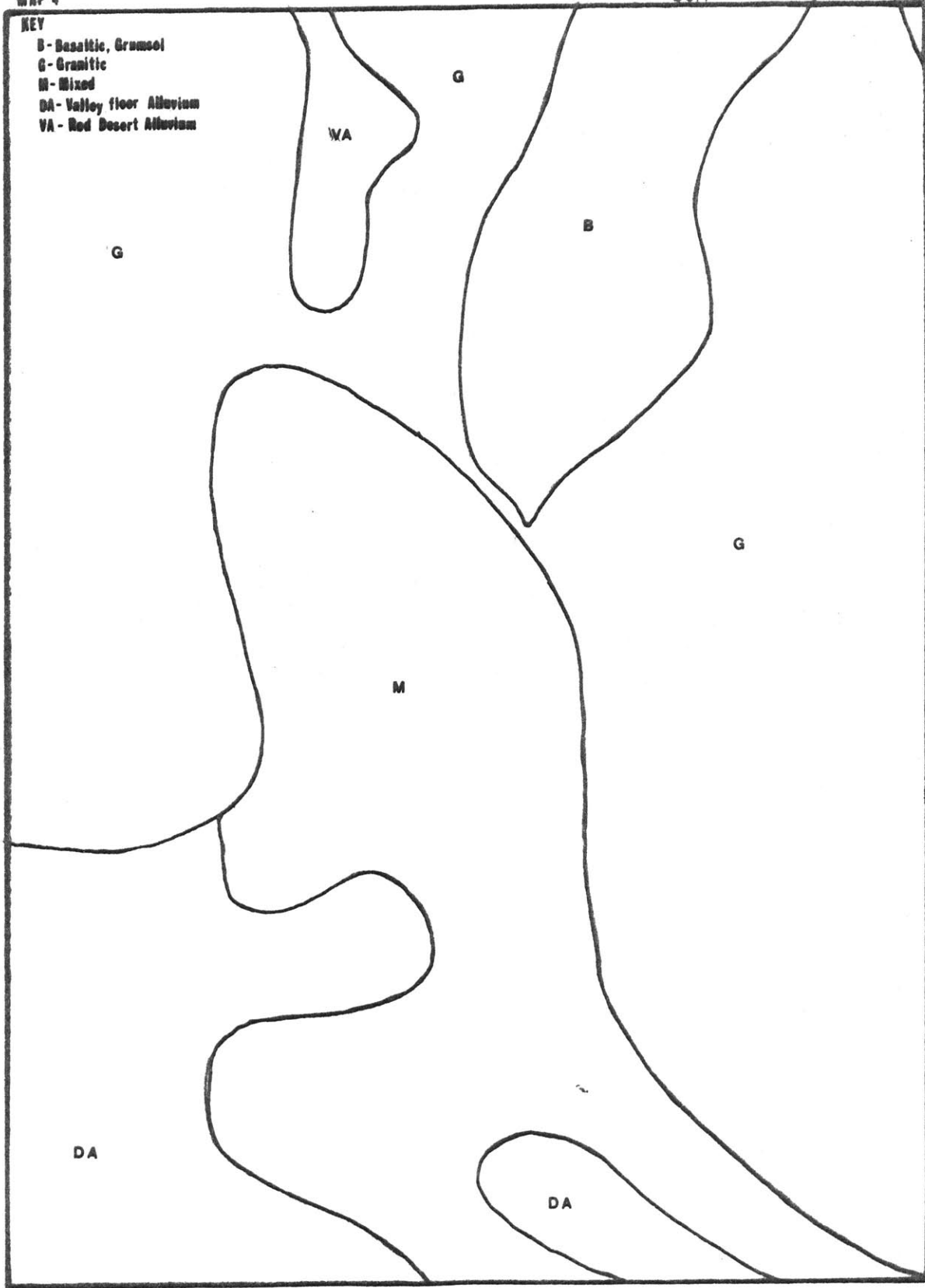

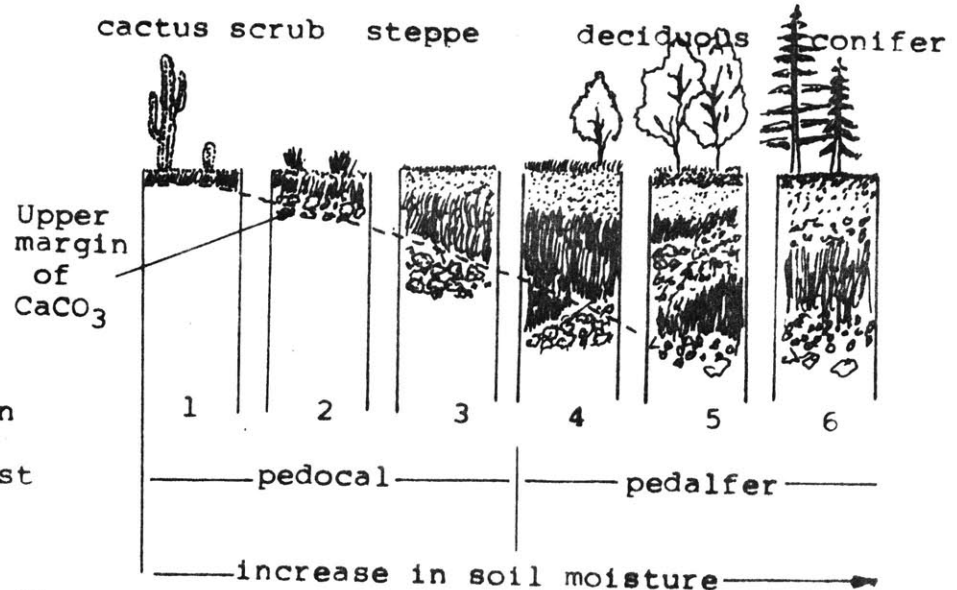

The Reddish-Brown soils are the most abundant in this region. These soils

have a reddish brown to red surface color and an even consistency. These soils

which have high inherent fertility appear under short grass vegetation at elevations above the lower valleys.

The Red Desert- Calcisol soils occurring in the southern portions of the site have a surface color which ranges from light pinkish-gray to reddish brown or red. The upper subsoil often is a deeper red than the surface and is compact. The lower subsoil is pink to light gray, rich in lime and mineral nutrients. When irrigated these soils are highly productive.

Igneous soil in this region is known as Grumsol. Grumsols are reddish-brown or brown clay soils weathered on volcanic rocks. These soils are fertile, containing few soluble salts or alkali. This soil contains a high percentage

- 1 Sierozems
- 2 Brown semi-desert soils
- 3 Chestnut-brown soils
- 4 Chernozems
- 5 Grey-Brown Podzolic soil
- 6 Podzols

of clay of the expanding lattice type. During the dry season, the soil shrinks severely and then upon wetting during the rainy season, July and August or late winter, they swell. These soils also have the unique property of churning to depths of twenty to forty-eight inches. After a rain, water first fills the cracks in the soil causing lateral expansion to occur in the vicinity of the crack and ultimately forcing the surface soil down into the crack, the churning motion.

GEOLOGY 24

The soil and rock fragments covering the earth's surface are its rug or regolith. In regions of consistent rainfall this regolith is concurrently consistent with a fine texture of curved hills fashioned by downslope motions of creeping clay. In the desert this continuity does not exist. Here the regolith is thin and coarse causing the slopes to occur in a consistently coarse texture. The slope angles are steep because the forces required to move larger particles are greater.

Even in deserts the most geologic work is done by water and not by wind. Even though most streams disappear soon after they originate by evaporation, the typical violent storms accompanied by flash floods will move heavy loads of sediment suddenly and quickly. In the flood the side-slopes are undercut causing steep ridges between slopes and a flat alluvium floor. The result is a steep sided box canyon.

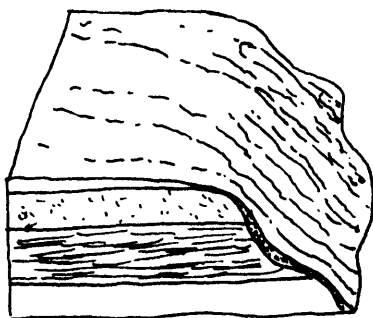

Moist climate

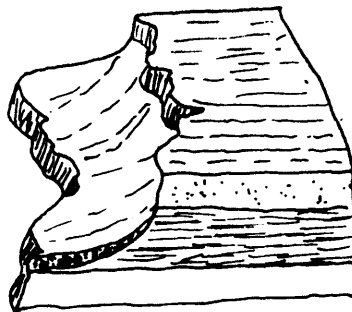

Dry climate

The desert lands are sculpted quite differently from lands with more rainfall. Mountain slopes in an arid land continually erode a slope or rocky pediment which builds up between alluvial fans. This pediment is eventually the successor of the mountain by uneven periods of erosion by dissecting branches of arroyo. Wind, the force most effective and prevalent in shaping the intricacies of desert sands, has much less of a contribution to shaping this region. Only when the mountains have submerged will the winds prevail.

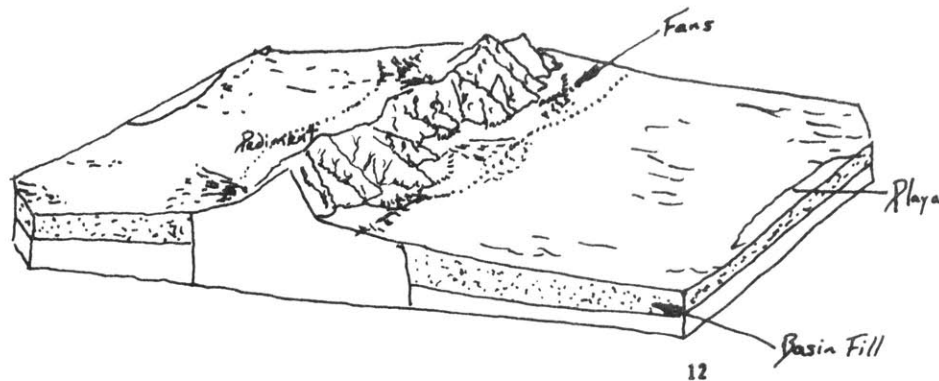

The divisions of the geologic map include:

- F - Flood plains and low terraces
- A2 - Terraces and Alluvial Fans
- A1 - Folded Gravels
- Va - Faulted Volcanic Rocks, Basaltic flows, Tuffs and interbedded alluvium
- G - Granitic and other crystalline rocks, locally including red rhyolite
- M - Metamorphic Rocks, including shist, gneiss and greenstone

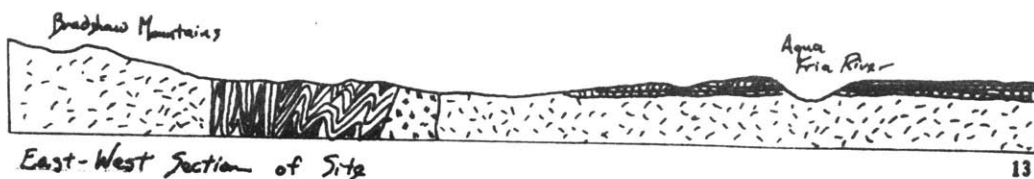



MAP 5

Geology

- KEY**
 F - Floodplain
 A2 - Terraces, Alluvial Fans
 A1 - Folded Gravels
 Va - Volcanic
 G - Granitic
 M - Metamorphic



VEGETATION 2.5

Aridity mummifies a landscape by slowing down the rates of change just as the dry sand and desiccating air preserved the Egyptians and Peruvians for thousands of years. After two or three years a saguaro seedling is only a few millimeters high and after ten not even an inch. Similarly the communities of this region are comprised of those relatively few plants and animals which have adjusted physiologically to the harsh environment. To disturb any part of this environment, to remove even one of the dominant species can throw the entire plant and animal community out of balance and destroy its relative stability for unusually extended periods.

The environment can be characterized by as many variables as are measureable, each variable complicating the analysis of its effect. Frequently temperature and moisture are chosen to evaluate the response of vegetation to gradients of these factors. However it is evident that a study of a mountain down its slope will show increases in temperature, decreasing moisture, finer soil texture as well as a change in wind, humidity and exposure.

Since greater topographical diversity creates greater diversity in microenvironments it is expected that the diverse transition zone will contain a more complex pattern of vegetation than either the lower desert, basin and range or upper mesas, the mesa-canyon complex.

DISTRIBUTION OF PLANTS DUE TO SLOPE,
EXPOSURE AND COLD AIR DRAINAGE

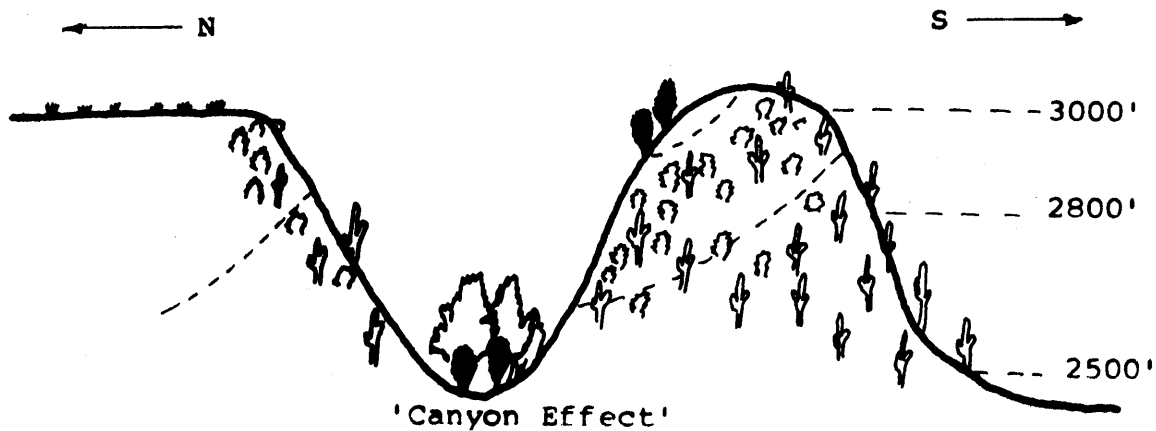

The Canyon Effect is an illustration of the diversity created by local topography. At 2800 feet similar soil characteristics, slope angle and rainfall will produce quite different vegetation depending on orientation. North facing slopes retain more water and are cooler than south slopes primarily because of insolation. Species such as jojoba, false paloverde or octotillo which are typical of higher altitudes will occur on the north slopes while species of lower elevations, saguaro, paloverde and bursage will grow on south slopes. Due to the displacement of warmer air upslope, the collection of runoff and increased shade allow distinctly riparian species, like cottonwood and

- ↓ Saguaro
- Jojoba
- Scrub Oak
- ☁ Cottonwood
- ☼ Grass

scrub oak, usually growing at elevations above 4500 feet are found at the canyon bottoms. The saguaro's upper limit is reached where freezing temperatures throughout a 24 hour period occur.

The lower limit occurs from the decrease in moisture occurring when silt and clay increase in proportion to rock and gravel.

The Vegetation map

Map 6, is divided into

5 categories:

O - Desert Scrub

Y - Grassland

B - Woodland

P - Chaparral &

Mountain Brush

G - Coniferous Forest

Desert Scrub, creosote bush, bursage, acacia, occur in sandy and fine textured soil often with caliche. Chaparral & Mountain Brush - palo verde, cactus - occur in coarse textured gravel or

LAND FORMS & SOIL CONDITIONS	BASIN-AND-RANGE PROFILE	VEGETATION TYPES
<u>Leading Mountain Slope</u> Shallow, Rocky or Gravelly Soil With Good Drainage No Subsurface Water		<u>Yucca-Agave-Sotol</u> Yuccas, Agaves Ocotillo, Sotol Turpentine Bush Prickly Pears False Mesquite
<u>Upper Bajada</u> Coarse-Textured Rocky, Well-Drained Soil Partly Underlaid by Rock Bench No Subsurface Water		<u>Palo Verde-Cactus</u> Palo Verde, Saguaro Ocotillo, Ironwood Prickly Pear, Cholla Ephedras, Brittle Bush Jojoba, Bur Sage
<u>Lower Bajada</u> Sandy and Fine-Textured Soil often with Caliche Hardpan No Subsurface Water		<u>Creosote Bush</u> Creosote Bush Bur Sage White thorn Cat Claw Acacia
<u>Bottom Land</u> Fine-Textured Soil with Poor Drainage and Low Salt Content Subsurface Water Available		<u>Mesquite</u> Mesquite, Cat Claw Saltbush, Lygium Juniper
<u>Salt Flat</u> Similar to Bottomland but with High Salt Content		<u>Willow-Cottonwood</u> Willow-Cottonwood Amaranth, Bortanomy
		<u>Saltbush</u> Saltbush, Grassweed Pickleweed

MAP 6

Vegetation

- KEY
O - Desert Scrub
Y - Grassland
B - Woodland
P - Chaparral
G - Coniferous Forest

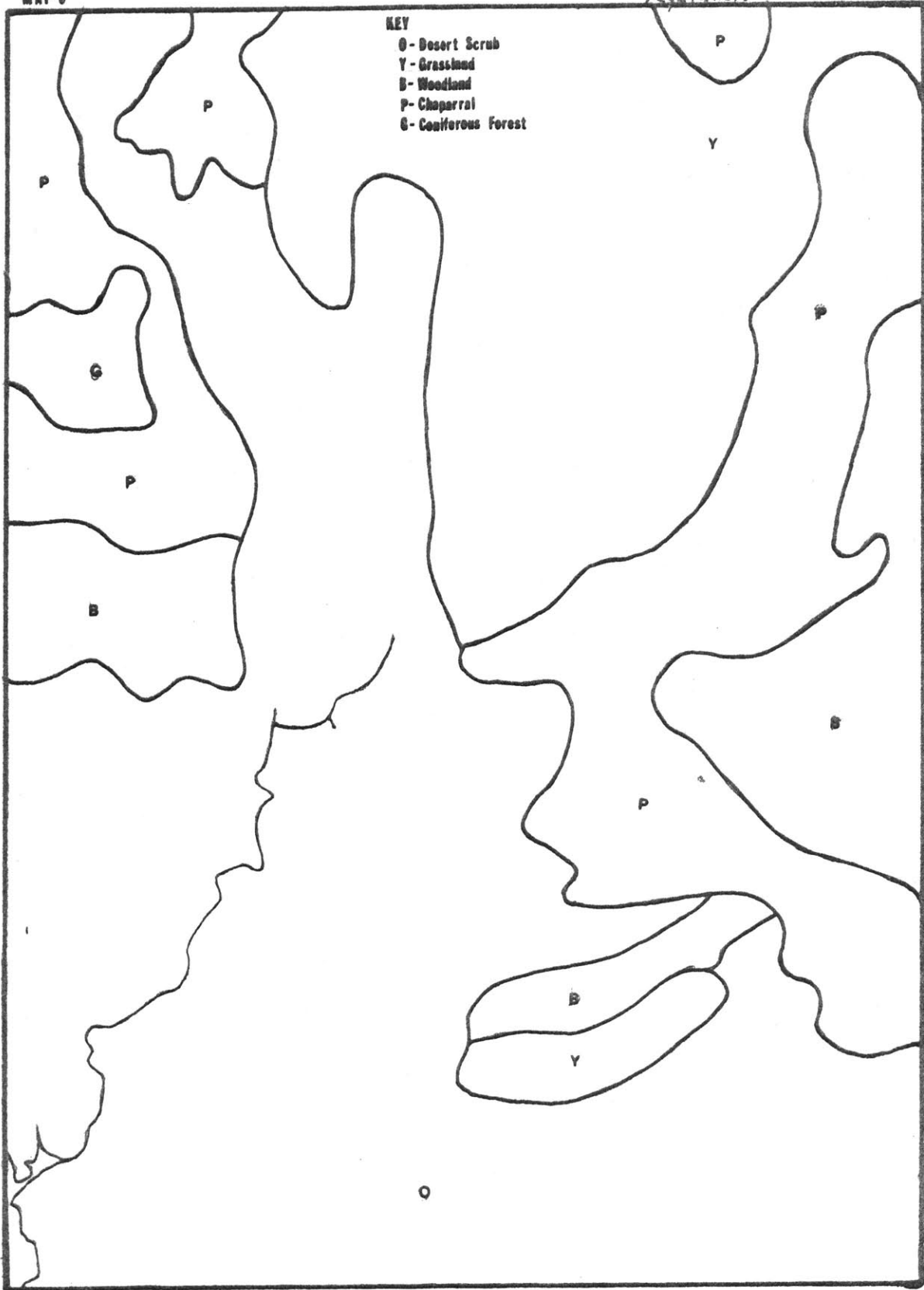

rock. Woodlands occur from locally modified water availability. These include varying densities of Populus, Salix, Fraxinus (broad leaf deciduous trees) and in drier washes at higher elevations: Prosopis, Aciacia, Chilopsis (narrow leaf trees). The Coniferous Forest is primarily composed of Arizona pine, similar to the more widely known ponderosa pine, at elevations above 6500 feet.

A study conducted by a group of botanists in this region reinforces the expectation of diversity in the transition zone with the following data:

		Subshrubs	shrubs	Succulents
Basin&Range	Desert Scrub	16	22	18
Transition		51	29	19
Mesa-Canyon	Grassland	16	5	5



RAINFALL 26

The distinction of desert is due to rainfall. The range is usually stated as less than fifteen inches but more accurately when the total evaporation exceeds precipitation. Most deserts occur in the high pressure latitudes from 25 to 30 degrees. Extension of deserts from these latitudes is due to the shape of the land. Mountain ranges force moist air to rise and condense thereby shadowing the leeward side. The strong north-south extension of the Sonoran Desert exists because of this action, the moist air from the Pacific which rises before the coast range of California shadows the land to the east.

Four main factors favor precipitation: moisture, mountainous terrain, convergence or air flow from the south and thermal heating. The existence of moisture is not enough. There must always exist some mechanism mechanical or dynamic to cause air to rise and cool sufficiently for condensation and cloud formation to occur. As the coastal

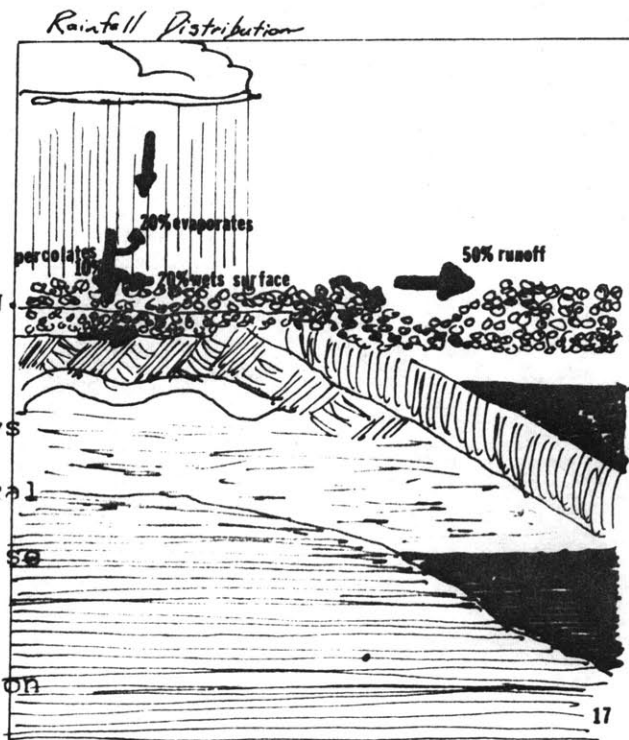

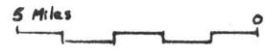

MAP 7

Rainfall in inches/year

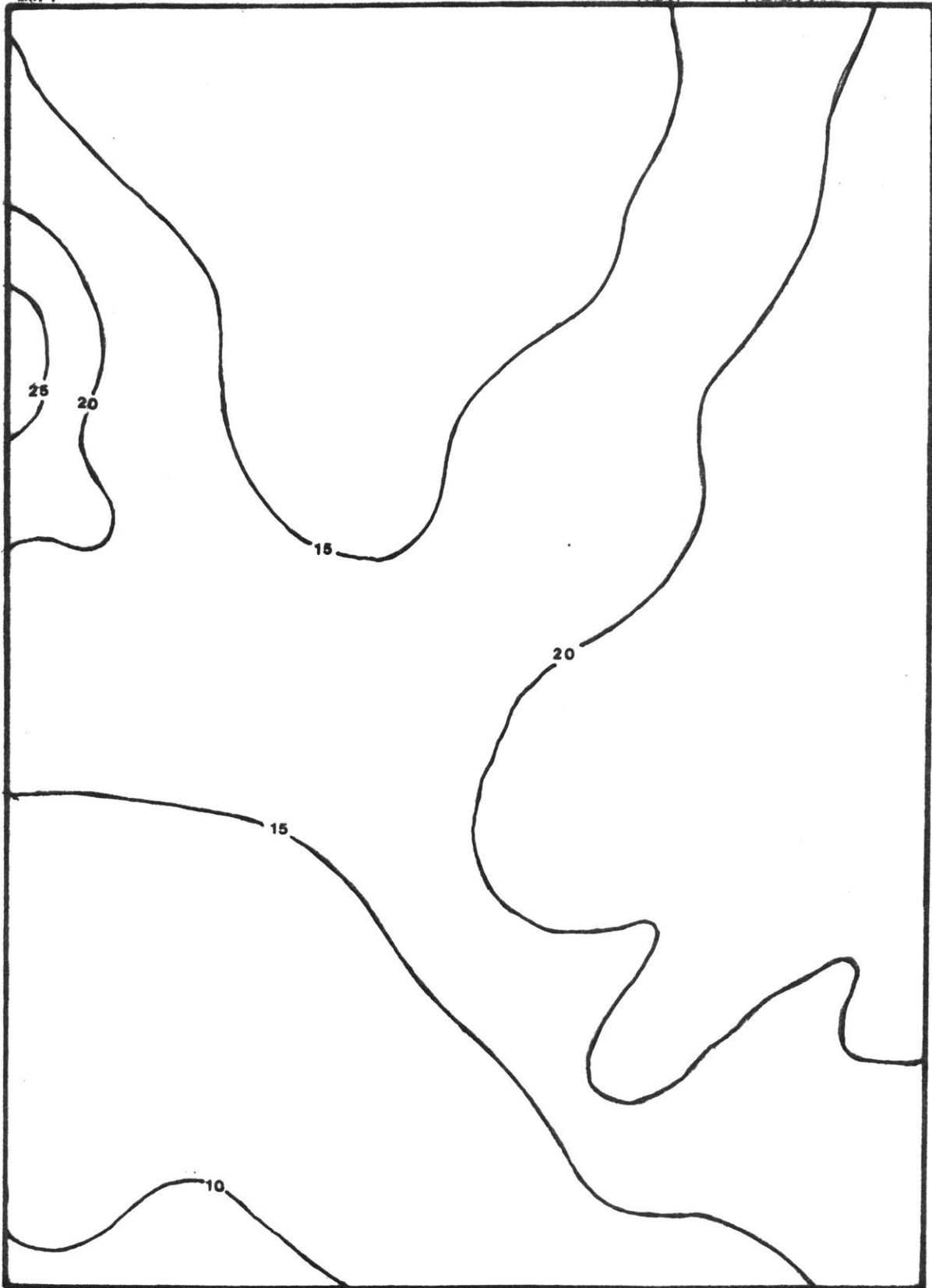

continental range blocks rainfall to the east so precipitation is usually heaviest on windward slopes of mountain ranges (west of the Brooklyn Peaks). The nature and intensity of precipitation depends a great deal on the temperature difference between the earth's surface and the rising air. When the ground is hotter than the overlying air a thermal of rising air occurs which peaks with a cloud formation. This thermal convection combined often with general air mass convergence or intense upslope flow is associated most often with showers or thunderstorms.

When rain falls on the desert most of it eventually is evaporated into the atmosphere. On the average usually ten percent first percolates in to the soil, usually from five to twenty inches in depth. Twenty percent wets the surface of the ground and twenty percent evaporates almost immediately. The remaining fifty percent leaves the area as runoff. Factors which bear on the extremely variable rates of water movement after rainfall include: rainfall intensity and duration; magnitude and velocity of streamflow; point of entry into the groundwater reservoir, including the hydraulic gradient; and permeability of subsurface rock materials.

RUNOFF 2.7

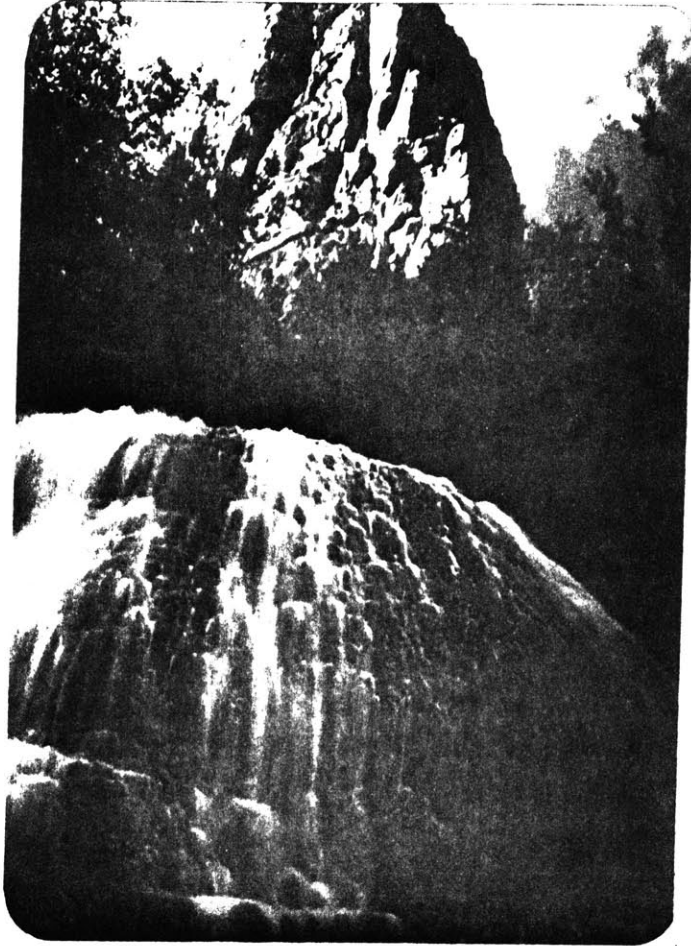

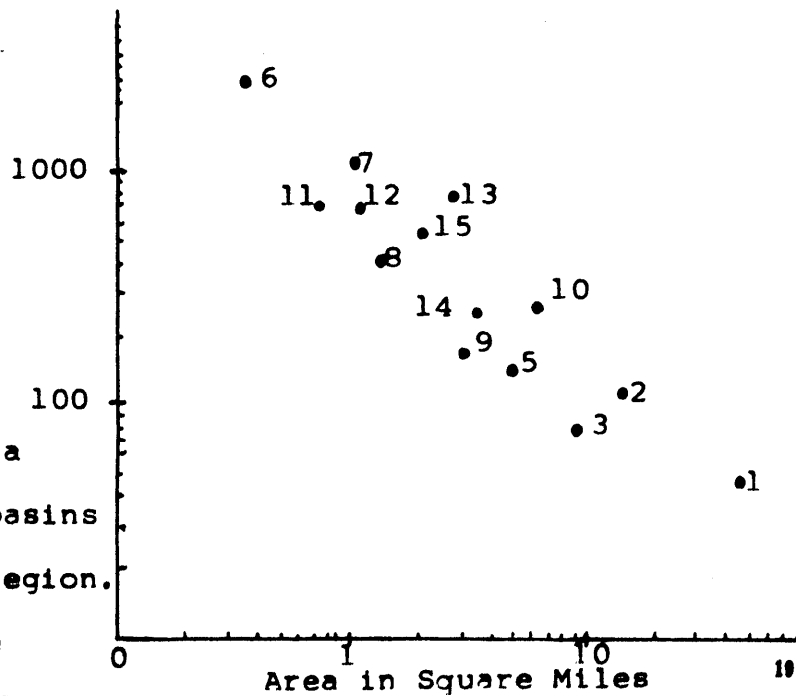

This graph is a comparison of the basins identified in the region. Evaluation of these fifteen basins exhibits

a range of runoff as a percentage of estimated precipitation varying from 4.3% to 249.4%. In the table following which summarizes data of the basins, the area is in square miles; the elevation for highest and

Drainage Basins

1. Bishop Creek
2. Tank Creek
3. Lousy Canyon
4. Larry Creek
5. Soap Creek
6. Unnamed Wash
7. Daisy Mountain A
8. Daisy Mountain B
9. Daisy Mountain C
10. Cline Creek
11. Daisy Mountain E
12. Wild Burro Mesa - North Basin
13. Wild Burro Mesa - South Basin
14. Coles Wash
15. Unnamed wash, SW of 14

mouth of a basin; the type is the type of drainage; D-dendritic, T-trellis, P-parallel, first given is dominant; the runoff is in acre-feet per year; Ppt. is estimated mean annual precipitation in inches per year; and % is the runoff as a percentage of estimated precipitation.

MAP 8

Drainage Basins - Springs (or)

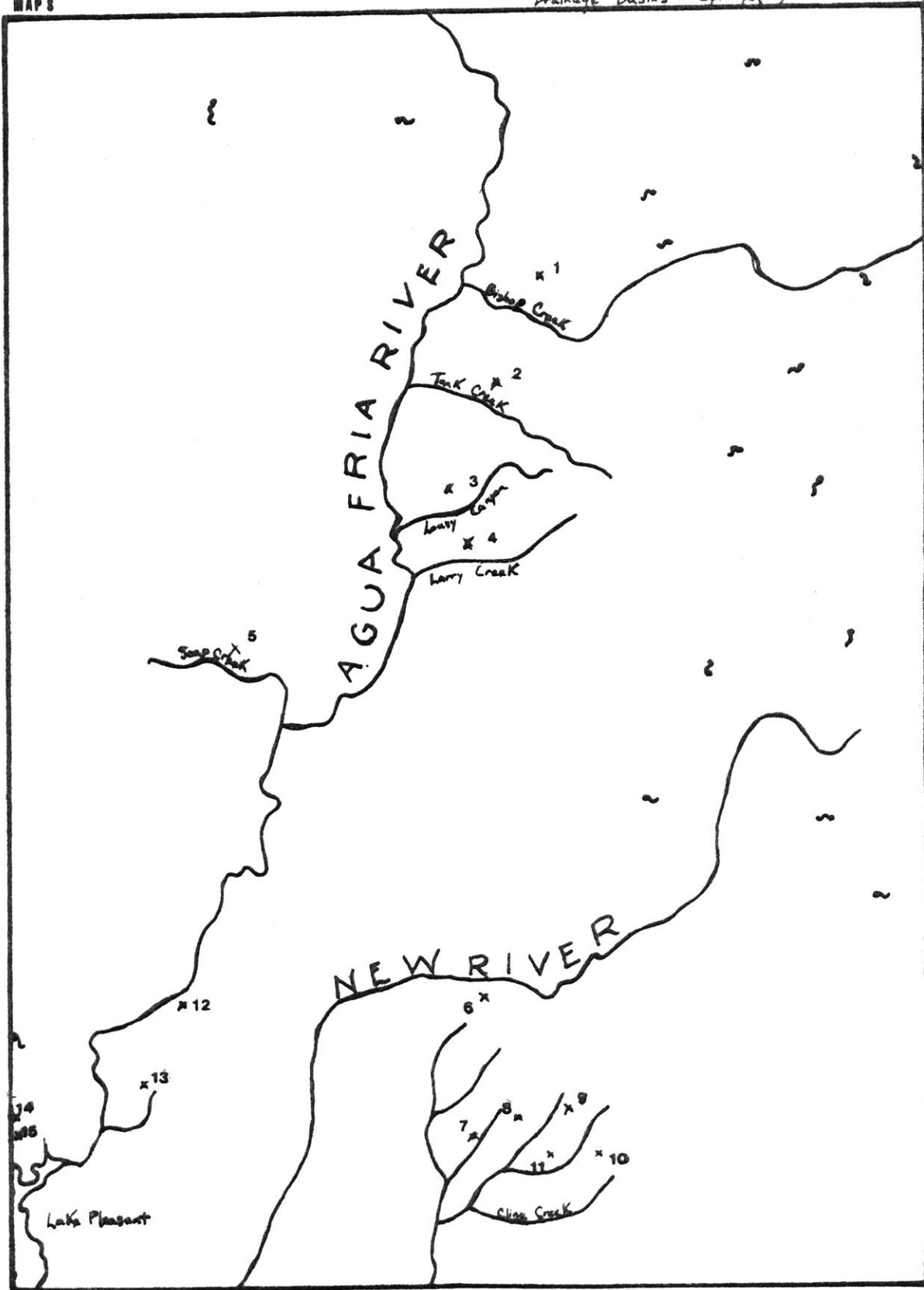

Basin	Area	Ele.	Type	Runoff	Ppt.	%
1	45.6	6814 3200	D	2098 1205	20	4.3
2	14.3	4840 2780	D	1575	18	11.4
3	8.6	4042 2400	D	-	16	-
4	9.0	4055 2260	D	653	17	7.9
5	4.8	5450 2000	T,D	656	17	15.0
6	.3	3500 2575	D	626	16	249.4
7	1.0	3000 2190	P,D	1145	16	129.3
8	1.3	3480 2140	P,D	528	16	46.8
9	3.1	4250 2310	D	494	16	18.8
10	6.4	4690 2230	D	1649	16	30.2
11	.7	3320 2245	D	506	16	83.7
12	1.1	2857 1720	D	737	14	89.9
13	2.7	2997 1690	T	2120	14	102.9
14	3.4	2030 1567	P	822	12	37.5
15	2.0	1930 1967	P,D	1064	12	82.7

GRADE 2.8

Percent grade for this region was mapped in five divisions:

- 5 - 60% slope and greater
- 4 - 30%- 60% slope
- 3 - 10%- 30% slope
- 2 - 5% - 10% slope
- 1 - Flat to 5% slope

To determine the relative slope, distance was measured between contour lines from a U.S.G.S. Topographic map. The relative continuities of these distances within an area allowed the site to be divided into fifty-one domains of the five slope ranges.



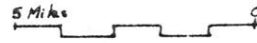

MAP 9

Grade

- KEY
- 5 - > 60%
 - 4 - 30% - 60%
 - 3 - 10% - 30%
 - 2 - 5% - 10%
 - 1 - flat - 5%

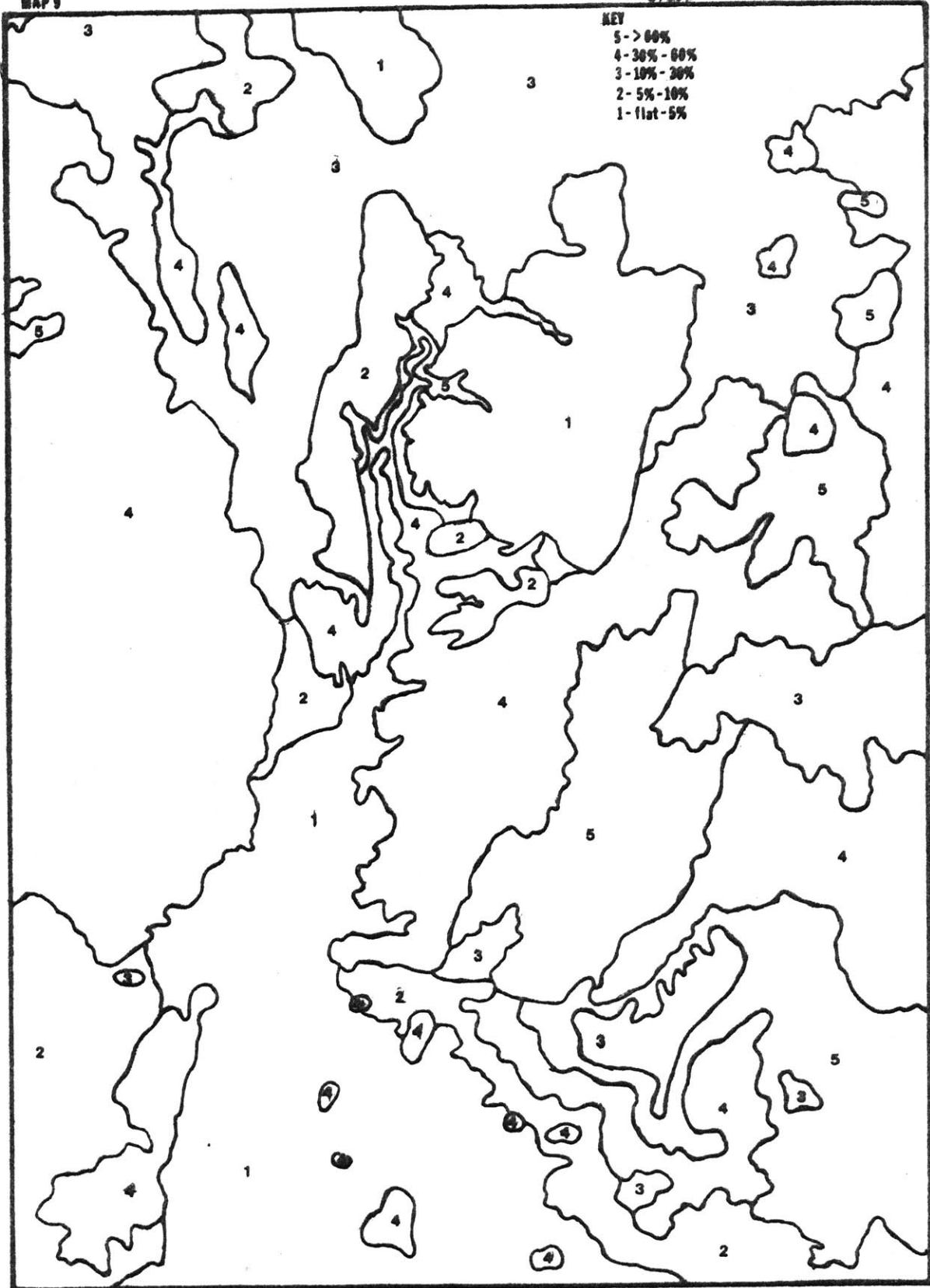

TEMPERATURE 2.9

The distributions of average maximum daily temperatures for January and July are shown on map 10. The dashed line is for January and the solid line is for July. Note how the isotherm lines progressively follow the path of the Agua Fria valley. The temperature of still air can be expected to drop an average of 3.5 degrees Fahrenheit (or 2°C) for each thousand feet of verticle ascent. This is due to the fact that the temperature of the air is primarily regulated by the surface of the Earth. Only 15 percent of the incoming solar radiation is

absorbed by the atmosphere. Eighty five percent of the atmospheric heating is caused by heating of the earth's surface below. Note the wide range in temperature between the average maximums and minimums for Jan. and July. For all

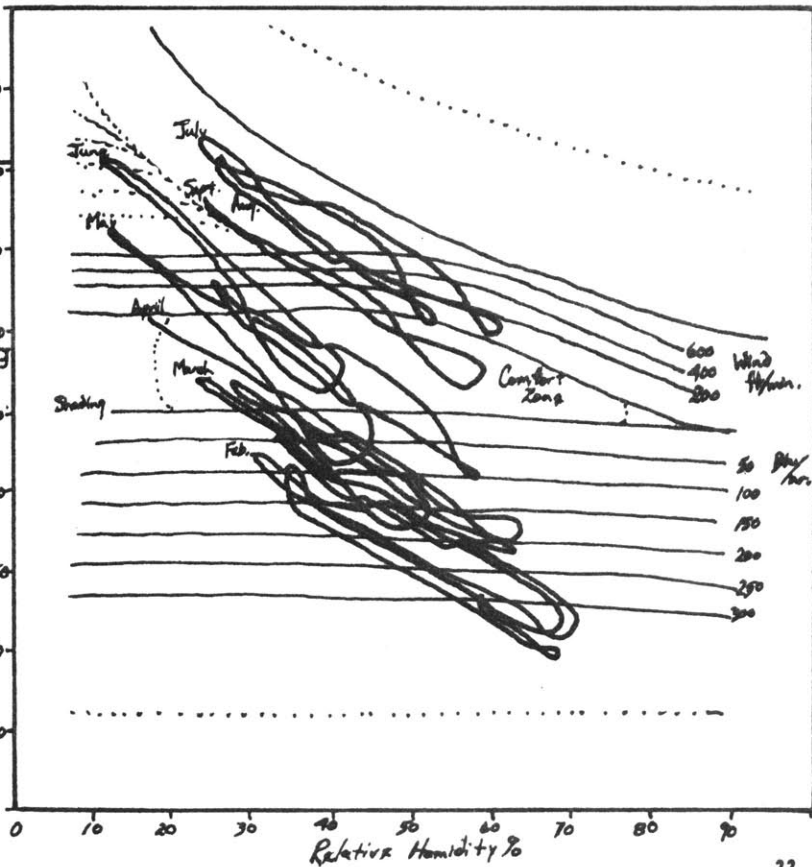

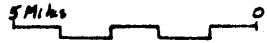

MAP 10

Average Maximum Daily Temperatures for January and July °F

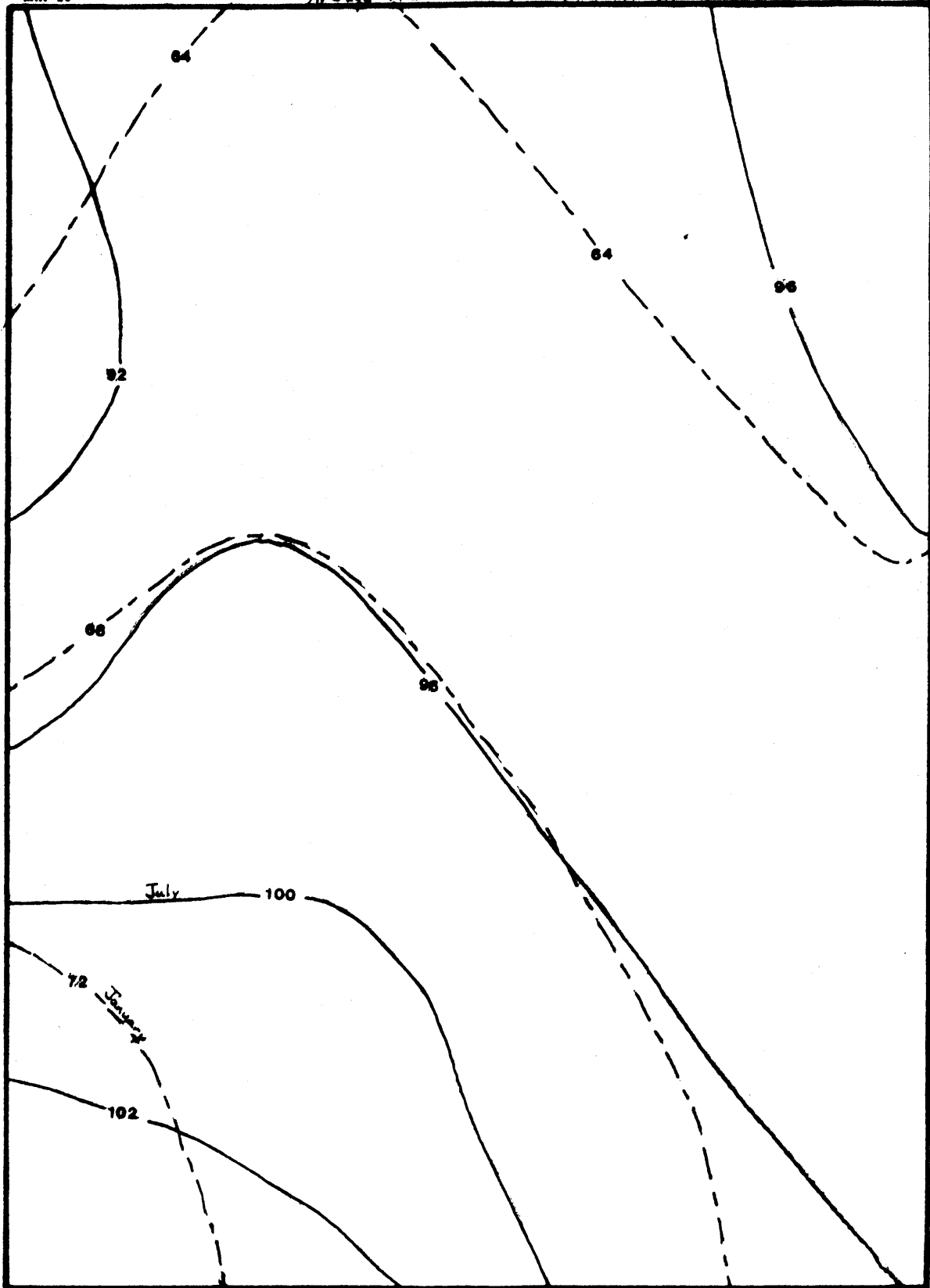

MAP 11

42
Average Minimum Daily Temperatures for January and July °F

5 miles

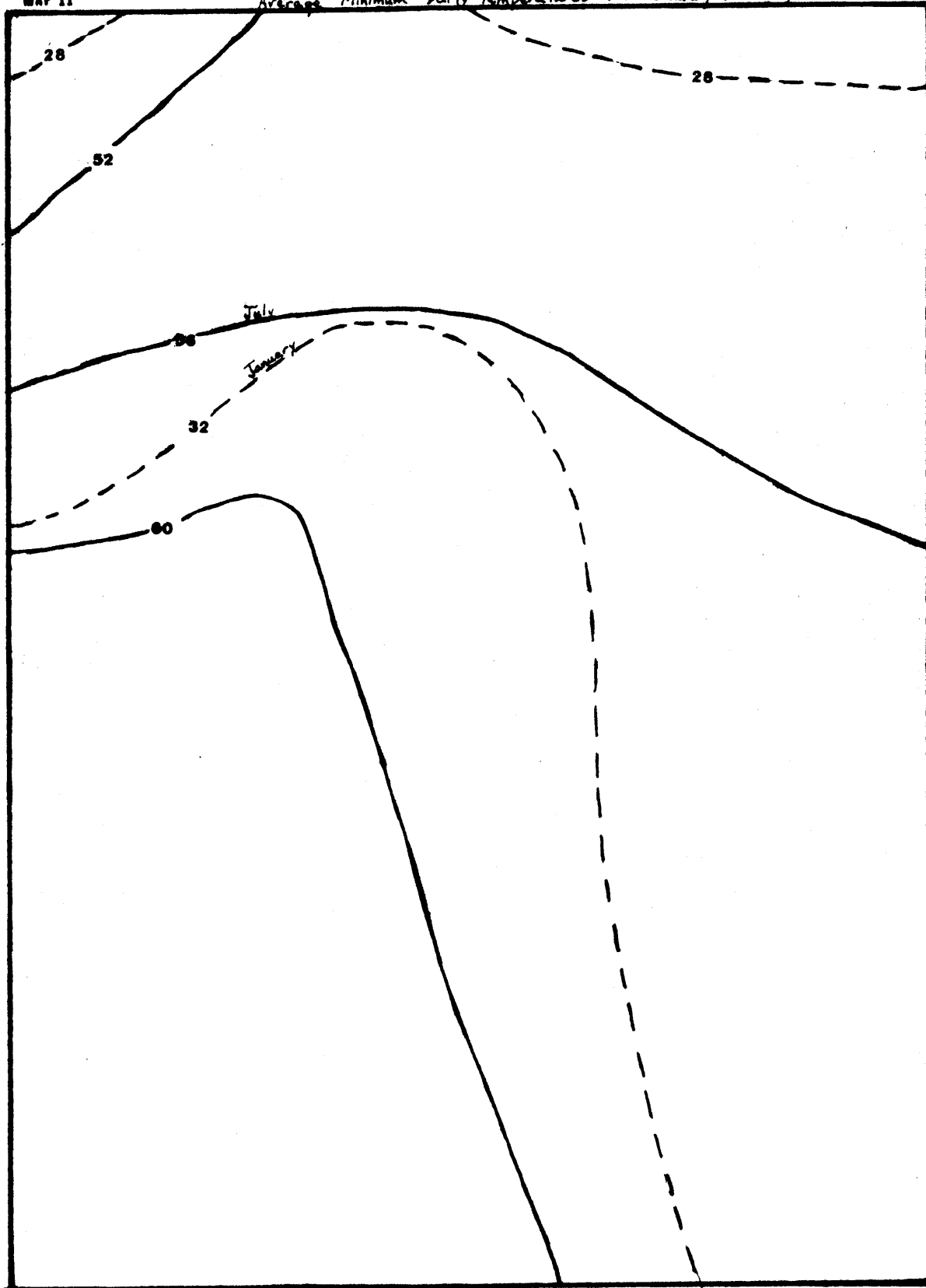

regions the diurnal temperature difference is high between 32 to 36 degrees in winter and 36 to 42 degrees in summer. In the winter the minimum difference occurs on the mesas while the maximum occurs in the valley plain. In the summer the maximum still occurs in the valley while the minimum occurs in the mountains.

At climatological stations all located above 1,000 feet elevation on slopes overlooking valleys it has been recorded that early morning temperatures in winter may be five to ten degrees higher than those recorded at nearby towns several hundred feet higher or lower. Due to their position on the slope they avoid the relatively cold air which drains off the mountains at night and yet are not high enough to be influenced by the normal decrease in temperature with increased elevation.

HUMIDITY 2.10

Annual Variation of mean Relative Humidity, Central Arizona

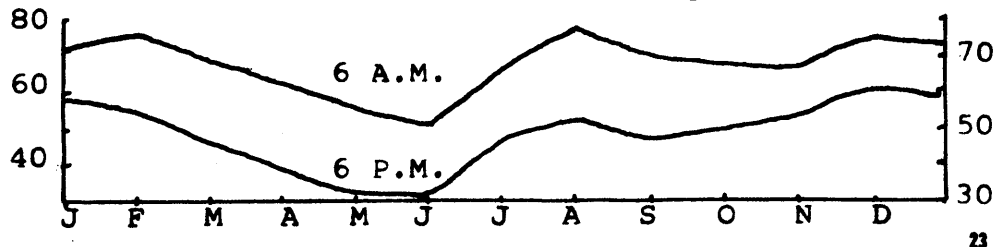

Relative humidity, usually expressed as a percentage is a function of moisture content and temperature of the air. If the moisture content is constant the relative humidity decreases as temperature rises. Therefore during a typical day the relative humidity will be at a maximum at sunrise and a minimum during early afternoon. In hot weather personal comfort increases with a decreasing relative humidity. To judge the combined effects of temperature and relative humidity, which usually change in opposite directions, the U.S. Weather Service has devised a temperature-humidity index (originally called the discomfort index):

$$\text{Temp.-Humidity index} = .4(T_{\text{air}} + T_{\text{wet bulb}}) + 15^{\circ}\text{F}$$

According to data of the Weather Service, most people feel uncomfortable when the index exceeds 79. Values above 86 are considered extreme.

Using the graph of relative humidity, map 10 - maximum daily temperatures and a psychometric chart to determine wet bulb temperature, the temperature-humidity index for

July can be determined:

		RH	Dry bulb	Wet bulb
July	6am	55%	60°F	57.5°F
			Temp-humidity index = 59.6	
	6pm	45%	102°F	83
			Temp-humidity index = 89	

EVAPORATION ^{2.11}

In 1915 the U.S. Weather Bureau established a network of stations around the country to measure the evaporation of water from what is known as the class A land pan. A land pan is 4 feet in diameter, 10 inches deep and is placed on a spaced timber platform so that the bottom of the pan is six inches above ground. A 3-cup totalizing anemometer with cups 2 feet above the ground is normally mounted on the supports of the pan.

Monthly evaporation from Bartlett Dam located just east of the study area a 33°49'N is a good indication of the evaporation from an open canal or cistern near the diameter of the pan or if a large open storage such as Lake Pleasant is estimated, reduce the land pan by 30 to 40 percent.

Average Evaporation in Inches, Bartlett

J	F	M	A	M	J	J	A	S	O	N	D
4.0	5.3	7.8	10.3	14.6	16.2	16.2	13.2	12.1	10.	5.7	4.5

Yearly Total 120.8 inches evaporation (rainfall 11.8"/yr)

Water Balance

- rainfall, inches
- pot. evapotranspiration
- actual
- water deficiency
- ||||| water surplus

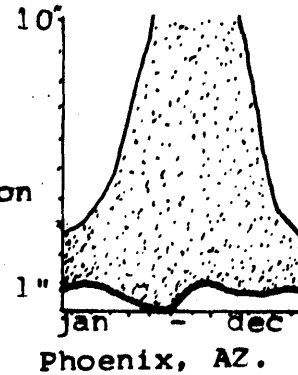

The effect of wind speed on evaporation is very noticeable. When a land pan at Davis Dam (in northern Arizona) was moved 1.5 miles north, up 129 feet to an exposed location where the wind speed was 250% greater the evaporation increased by 60%.

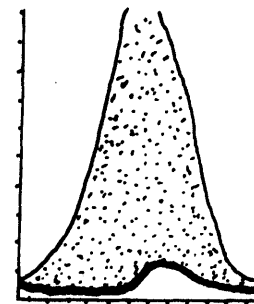

Winslow, AZ.

Potential evapotranspiration is defined as the total amount of water lost from the soil surface and through the stomata of plant leaves. This transpiration is effected by temperature, relative humidity, net radiation and wind velocity. A climatic water balance constructed using this data consists of a comparison of potential and actual evapotranspiration with precipitation usually on a monthly basis. The water surplus of Boston compared to the continual deficiency of water in the Arizona cities gives a visual description of the arid climate.

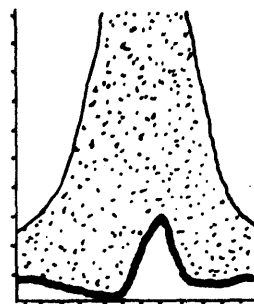

Tucson, AZ.

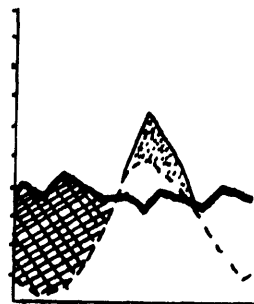

Boston, MA.

ARCHAEOLOGY^{2.12}

From a recent study by a group of archaeologists this region was last inhabited by a self-sustaining population approximately six hundred years ago. Further, a population had continually inhabited this region for one thousand four hundred years previous to that time. The following symbols represent the farming methods used on areas of this site.

- ≈ - Flood Plain
- ≡ - Linear Borders
- * - Terraces
- - Cleared Land
- [- Check Dam
- # - Waffle Gardens

Fields located in areas which are periodically flooded provides crops planted in such fields more water than would normally be received from rainfall and sheet flood alone. These fields were identified as flood plains by structure on adjacent areas, sherd or lithic (pottery) concentrations and the presence of petroglyphs on boulders.

The rows of piled rock which we happened to walk across enroute to our climb (pg. 6) were probably at one time agricultural terraces. Terraces are masonry walls or piled lines of rock located on and laying perpendicular to, a slope. The terraces serve the function of collecting and/or retaining soil in an attempt to create flat areas on a given slope which could then be used for farming. Terraces in this area are generally located on a slope of 30% with a range from 5%

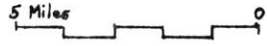

MAP 12

Prehistoric Farming Systems

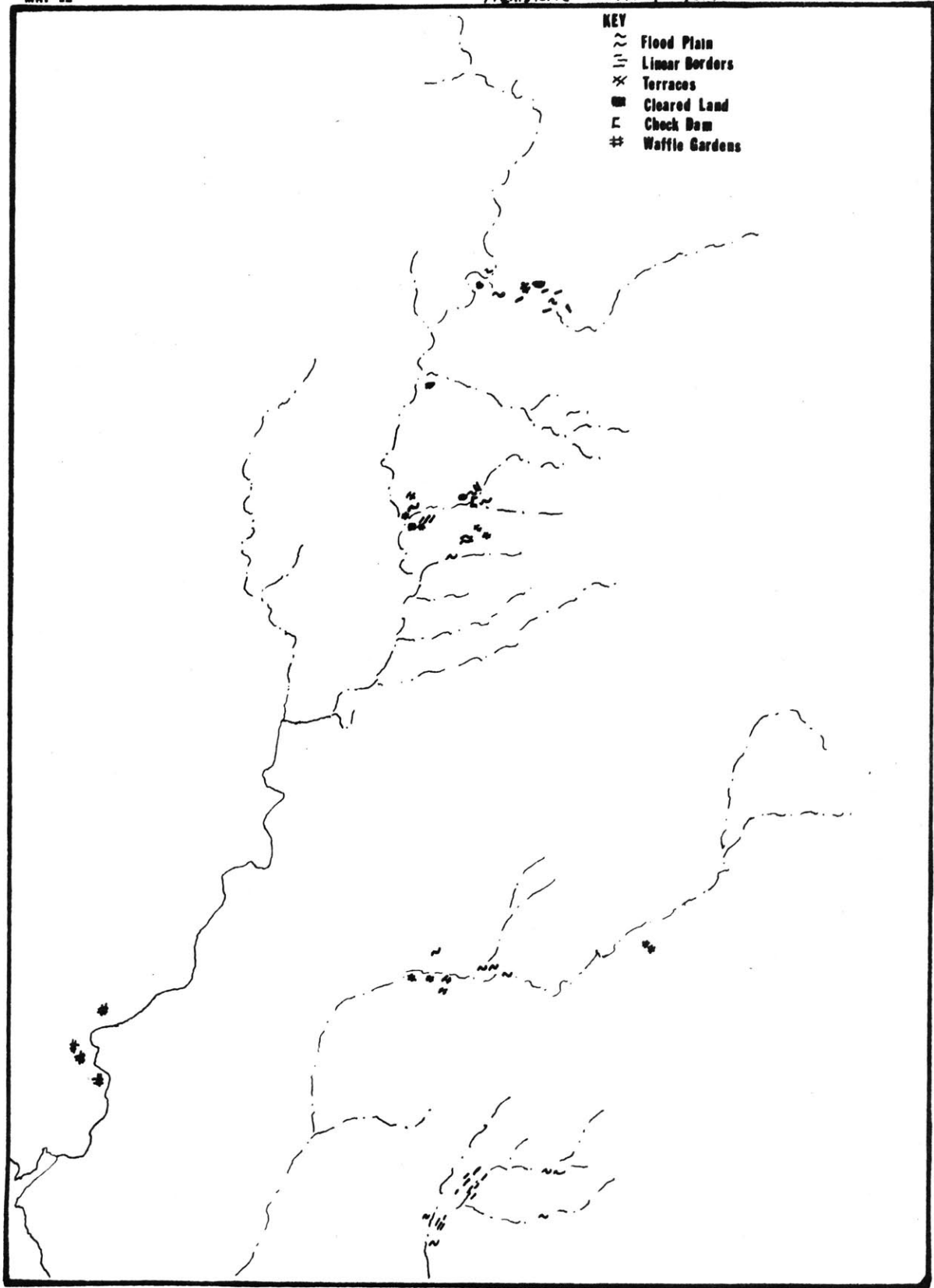

to 40%. The walls are generally constructed of unshaped boulders piled three to four courses high and average 20 meters in length. Terrace groups ranged from four to eighty-five separate walls.

Linear borders appear similar to terraces in appearance and structure but are functionally different. These walls are laid on an angle of perpendicular to the slope in an effort to prevent erosion and to redirect the flow of water.

Cleared land is identified by having had stones and boulders removed from them presumably to create open areas suitable for farming. Only areas with secondary evidence similar to that found at the floodplain sites were recorded.

Check dams are a type of terrace wall used in arroyos to slow or defer the direction of water flow out of the stream or to a backfill behind the dam which causes the stream to overflow its banks into surrounding fields.

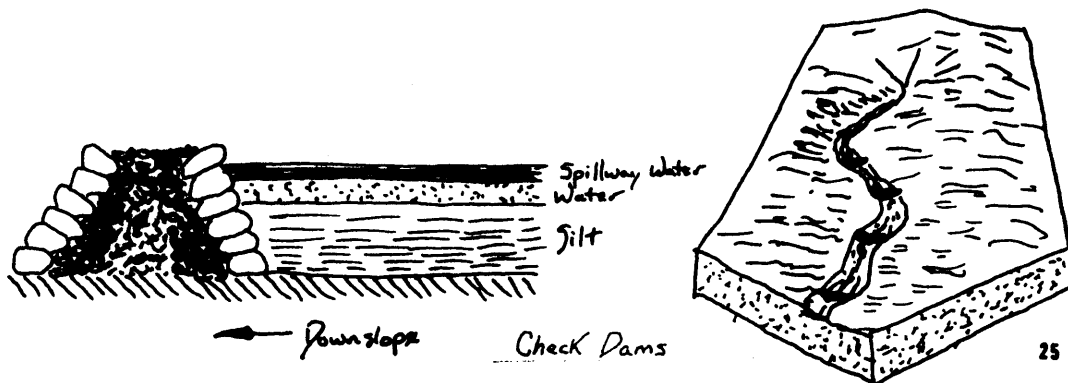

Hundreds of acres of waffle gardens were identified in the lower Agua Fria area. These are series of contiguous square borders of rocks on relatively flat gravel terrace of the Agua Fria. The system employs exclusive dry farming as their location is neither conducive to irrigation or watershed collection.

Accompanying the data of farming systems was the distance, and orientation to both the nearest water supply and the previous site of dwellings. In general for the mesa top region, a farming plot was located a short distance to the north or south of an arroyo, the water supply. Dwellings were to the east of a farming plot or to the south of the water supply corresponding to either flat land or the south slope. A diagram of this general site planning and the complete list of data for the mesa top follows.

Dimensions NSxEW	Slope(%)	(distances and direction to fields)	
		Dwellings(#)	Water
50x20	2	12 - SE 300m	S 200m
64x4	2	12 - S 450m	S 600m
55x50	4	11 -	S 600m
45x25	4	14 -	SE 700m
64x32	2	37 - N 800m	N 750m
30x25	2		N 700m
	2	10 -	S 300m
	8	60 - S 1.8km	W 20m
55x45	4	50 - W 750m	N 100m
62x30	2	12 - NW 1.1km	S 200m

Rims & Bottoms

Dimensions	Slope(%)	(distance and direction to fields)	
		Dwellings(#)	Water
NSxEW			
60x70	40	20	S 300m
70x45	20	50	S 800m
120x150	5	12- E 600m	S 200m
	30	50-NW 800m	N 350m
20x20	40	30- N 400m	N 25m
43x96	2	12-	S 300m
35x96	4	72	N 200m
3x42	20	37	N 100m
30x25	2	12- W 650m	S 100m
	30	10- E 700m	N 50m
13x48	8	50- N 100m	S 50m
35x25	2	72-SE 420m	N 50m
22x38	6	12- N 280m	S 25m
10x30	2	37- E 330m	S 10m
100x300	3	18- E 1.4km	N 25m
19x34	15	20- E 1.1km	N 450m
10x3	30	60-	E 100m
25x8	8	14- W 500m	S 300m
	2	12- E 80m	S 300m
	2	12- E 1km	S 200m

26

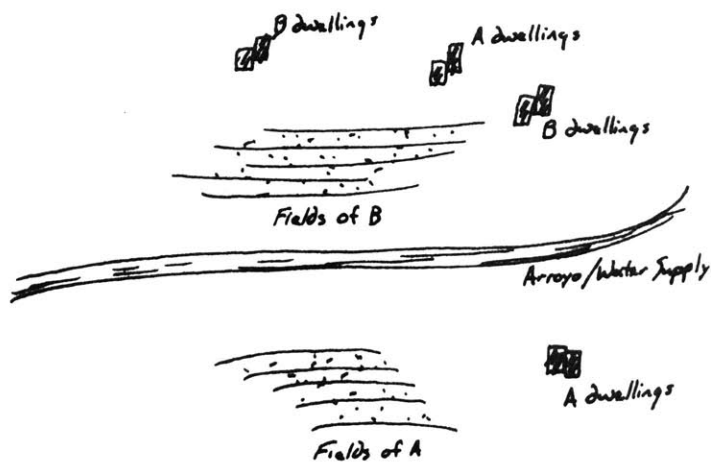

Typical Orientations - Dwellings/Fields/Water Supply

27

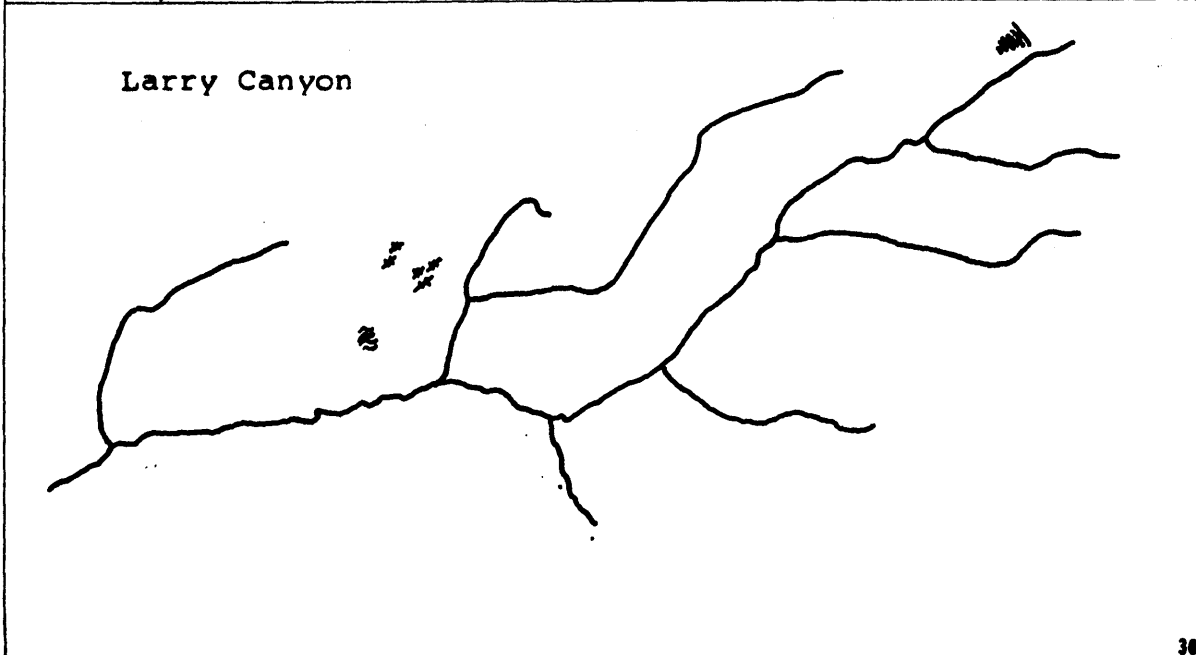
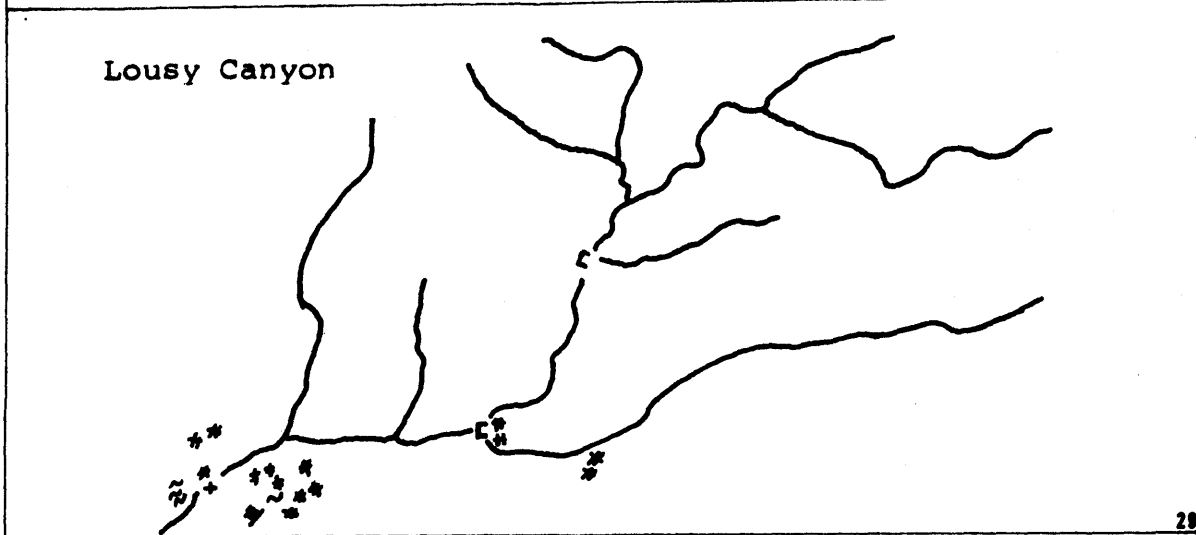
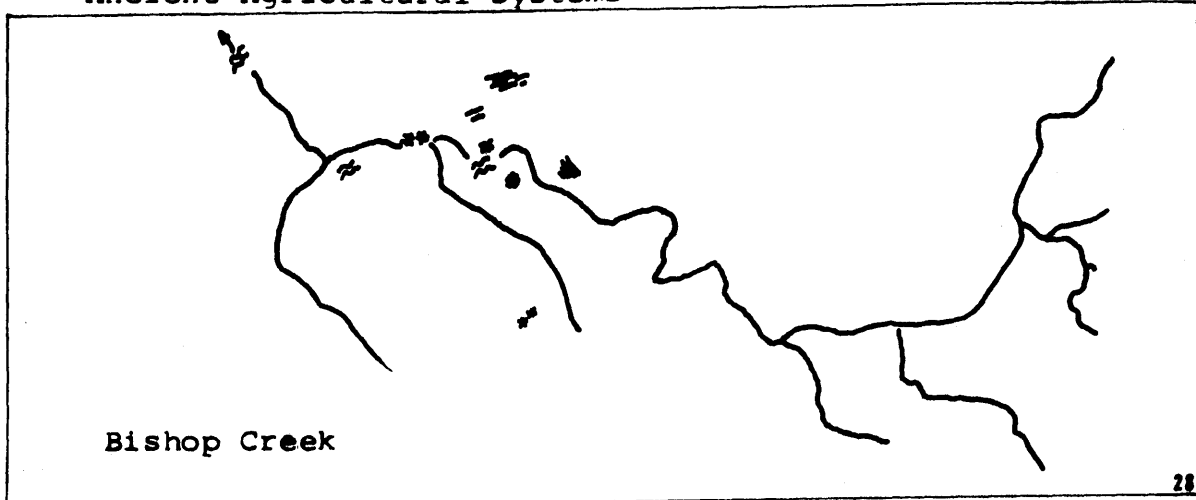

BUILDABLE LAND 3.1

When the initial planning of a new settlement or a single building takes place, the land which is possible to be built upon is NEVER the equivalent of a blank peice of paper ready for the free wheeling fantasies of a designer. Rather it is a reality of specifics exposed for a very long period to the effects of a multitude of modifying factors. Present and seldom accounted for is a product of geological, climatic, hydrological and precedential forces to assist in recoonition of a balanced response in design.

To determine the land of this region which is most suitable for building, each ecological characteristic thus far described will be evaluated and given a priority. Using these priorities the site will be progressively sieved through overlays of selected ecological characteristic maps. Even though the priorities determine the progressive range of possible buildable sites the final areas determined would be the same regardless of priority. It is the selection of determinants within the ecological characteristics which ultimately identify buildable sites.

The following determinants of the ecological characteristics are described in order of their priority for identifving buildable land.

1. SLOPE

The first priority selected for settlement planning is slope orientation. The ancient Greek word 'klima' means slope and was defined in order to denote different belts of the surface of the earth which had different weather conditions due to differences in solar radiation. A favorable slope orientation with regards to the essence of all climate, the sun, will determine local climatic condition within and without enclosed space. Using the optimum orientations of the angles between the south and southeast for this region, (section 2.2), the slopes of south and southeast will be identified as most appropriate for building.

2. WATER

The most prevalent characteristics of settlements in history have been natural defense such as the entrance to a pass and the existence of drinking water. Of least abundance and greatest need in this region is water. The prehistoric settlements in this area always existed within one mile of a water supply. That limit shall also be the criteria for site selection. The water supply shall include each major drainage basin and its primary network within this site in addition to existing springs.

MAP 14

South and Southeast Slopes within 1 mile of a water supply Point

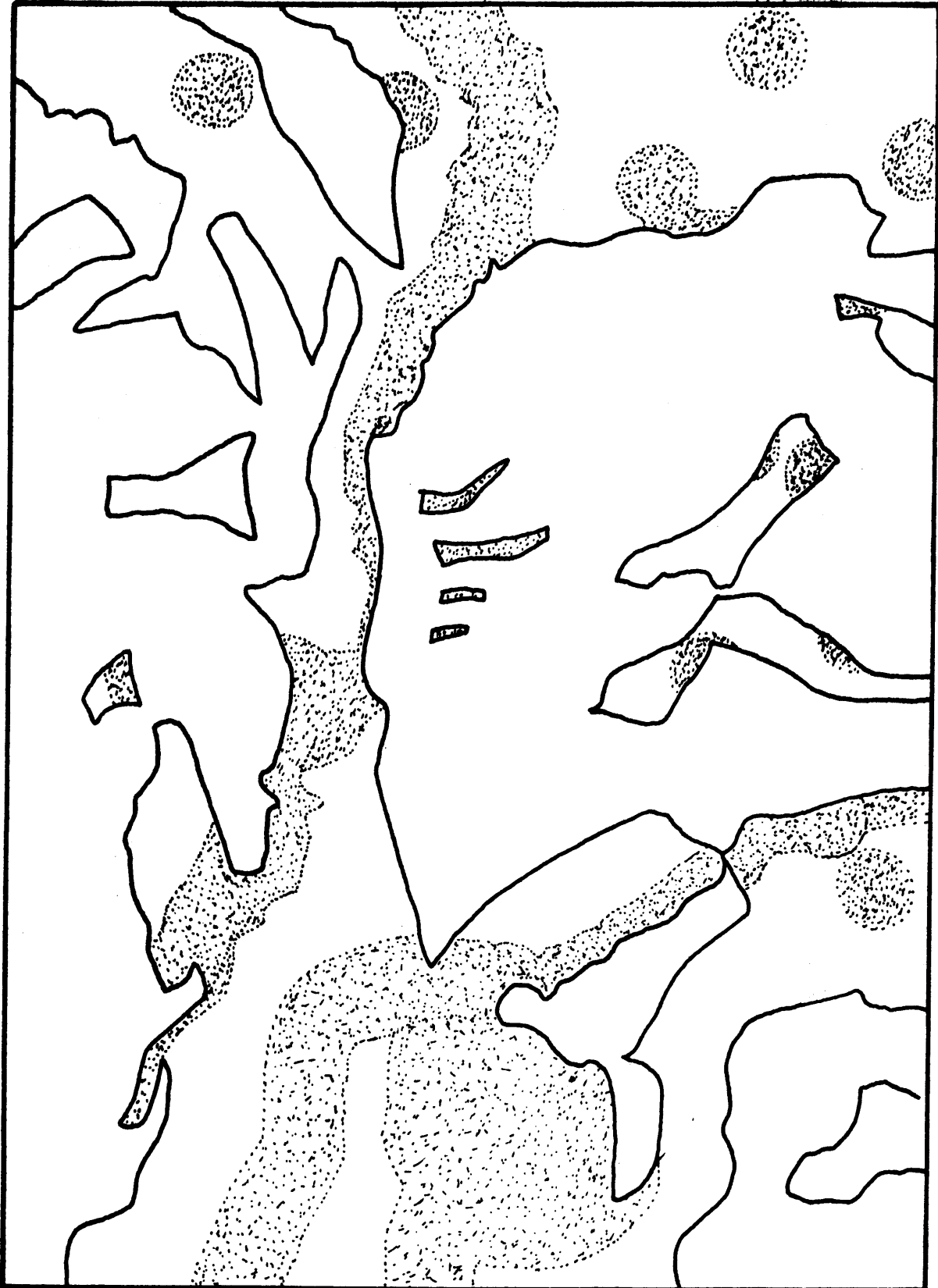

3. SOIL

The Grumsols of this region are the least stable for building. As explained these soils have the unique property of expanding, contracting and churning causing potential havoc to the entire building system. Expansive clay can exert pressures that exceed 30,000 pounds per square foot. It is unlikely that one can resist such pressures with non-yield construction. The regions of Grumsol will be eliminated as buildable land.

Secondly the skeletal lithosols indicating a thin layer of soil over consolidated bedrock would not be preferred for building sites. However, this soil was not identifiable as a domain at this scale.

The evaluation of bearing capacity, settlement, drainage, and actual soil content cannot be regionalized. The necessity for borings and tests to understand the specific ground where building is to occur is not feasible at a larger scale.

4. GRADE

Although grades above thirty percent are appropriate for mountaineers and potential rim guilds, the abundance of land with grades of thirty percent or less offers conditions of less energy intensity in terms of building and access. Domains of grade thirty percent or less will be selected as buildable.

MAP 15

Gravel regions eliminated - (not outlined) ----

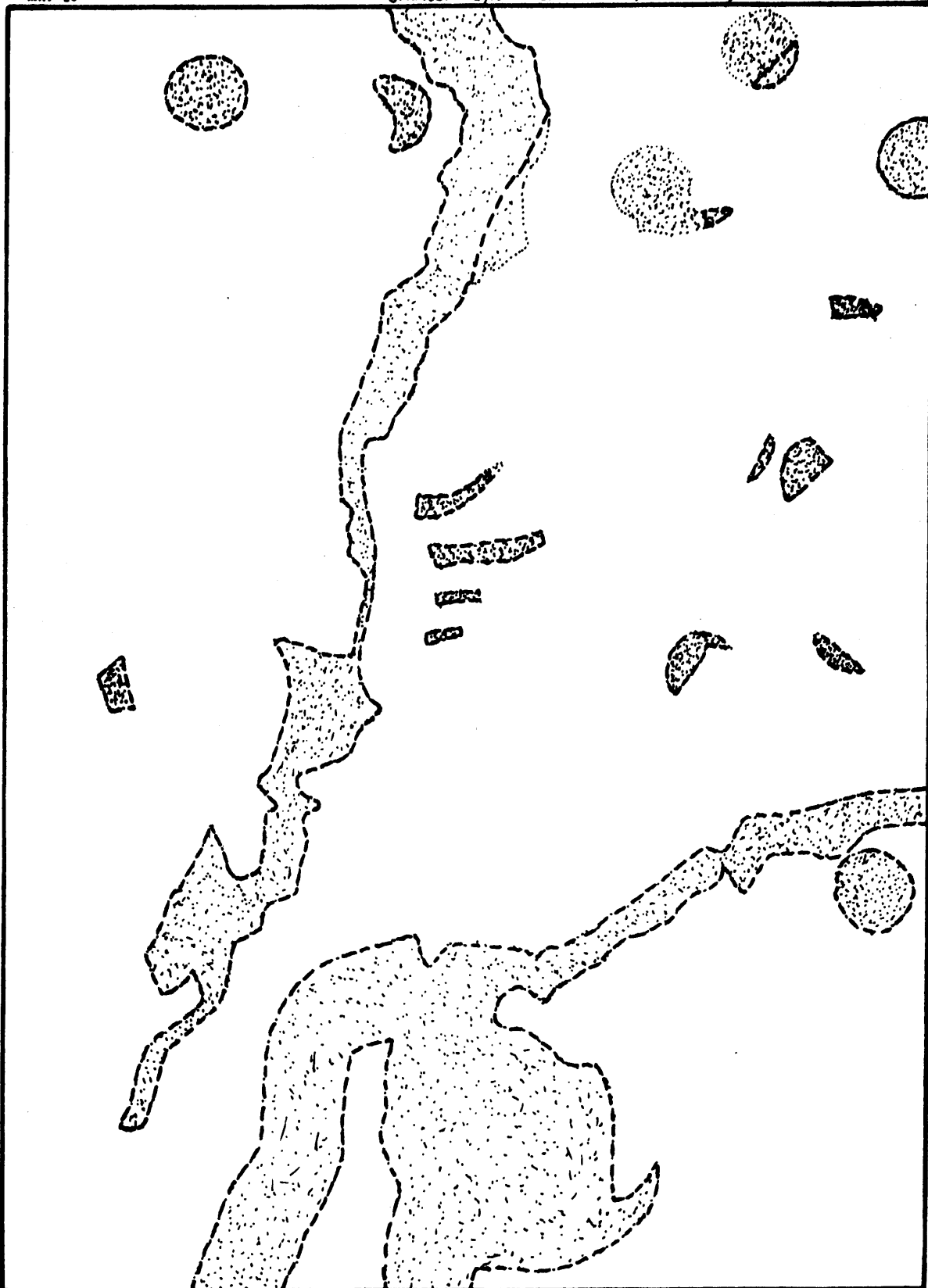

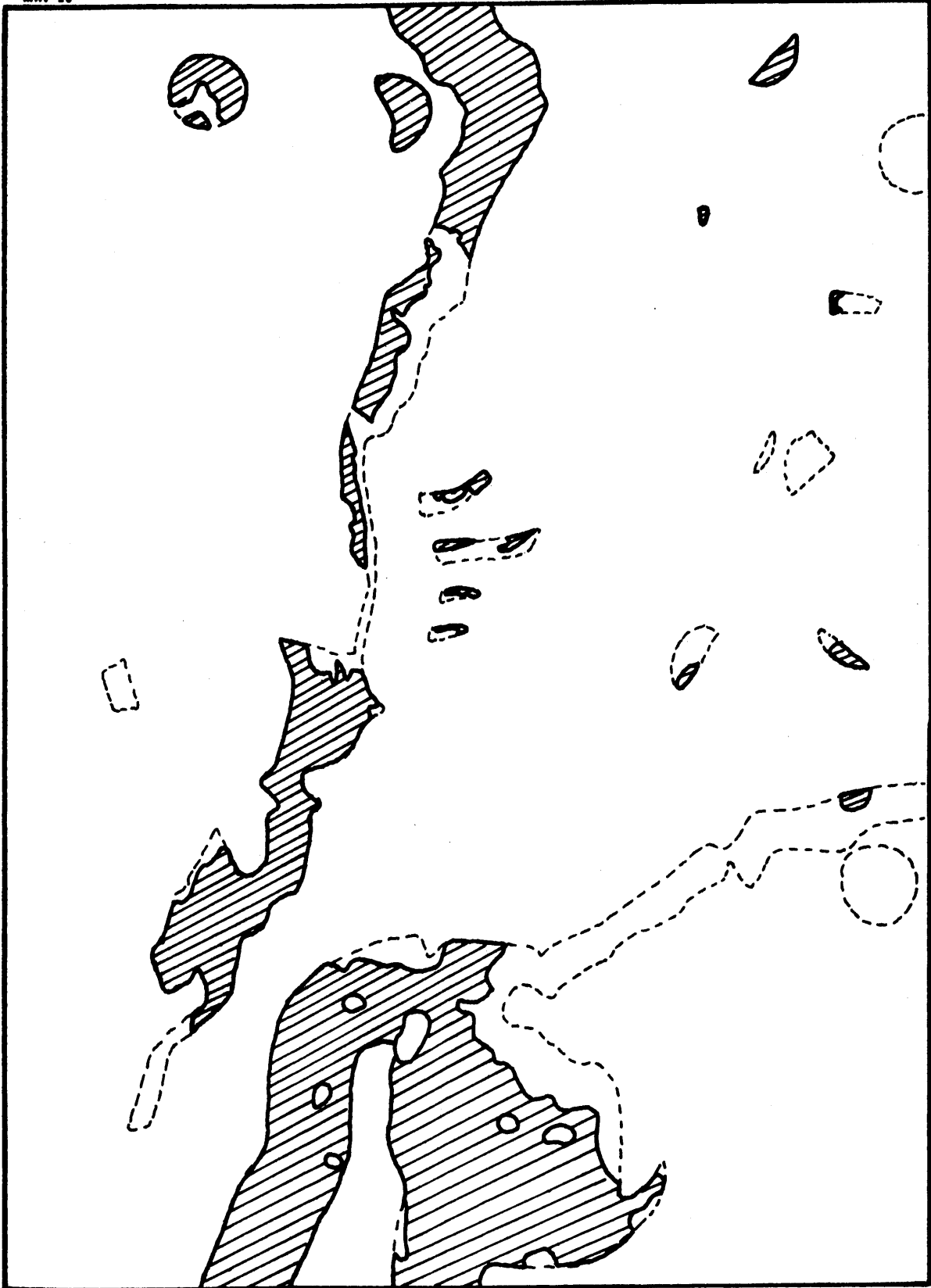

5. GEOLOGY

There are two primary methods for measuring the diggability of the ground. The first measures the sonic velocity of the earth. In this method a sound impulse is introduced into the ground with the time required for the sound to travel a fixed distance measured. The following table gives a comparison of relative diggability from this method. Velocities below 5,000 feet per second can be easily dug. Those above 5,000 will require blasting.

Air	1,100	feet per second
Topsoil	800 - 2,000	fps
Sand	1,500 - 4,000	fps
Clay or		
Soft Shale	3,000 - 7,000	fps
Water	5,000	fps
Sandstone	5,000 - 10,000	fps
Limestone	8,000 - 18,000	fps
Granite	10,000 - 20,000	fps

A second method is less applicable to this site due to the dryness of the soil. Electrical resistance of soil can also measure diggability but it is determined by particle size and moisture content rather than density.

Clay or saturated silt	1×10^4 ohms/cm
Sandy or Silty Clay	2.5
Clayey Sand or Saturated Sand	5.0
Sand	15.
Gravel	50.
Dry Sand or Bedrock	Over 500.

Though a large percentage of this region is comprised of granitic, sedimentary and volcanic rock, its depth

beneath the soil is highly variable and site specific. Therefore a buildable factor due to diggability at this scale is not reasonable.

The flow of a river especially the apparently dry banks of arroyos, dry river beds, which dissect this region are always variable and unpredictable. They are subject to erosion, overflows and flash floods, which can be common after a half hour deluge. The Floodplain is an organic part of the landscape, most frequently shaped and widened by the topography, gradient and annual discharge of a river or arroyo. Beyond the total destruction of a building on a floodplain, the construction can be difficult and expensive. Even if in this region the excavation is initially dry, the foundation will have to be watertight and be able to withstand hydrostatic uplift. Floodplains should be designated as non-buildable land.

There are no active faults in this area to particularly consider for earthquake stability however given the geological information, it is potentially more stable to build on soils with underlying consolidated rock than a less dense clastic rock, gravel, sand, clay or silt in decreasing preference. Further for increased stability, it is less wise to build across discontinuous strata, illustrated by the dividing lines called faults in a geologic section of the site. These faults, however, will not be used as buildable criteria in this analysis.

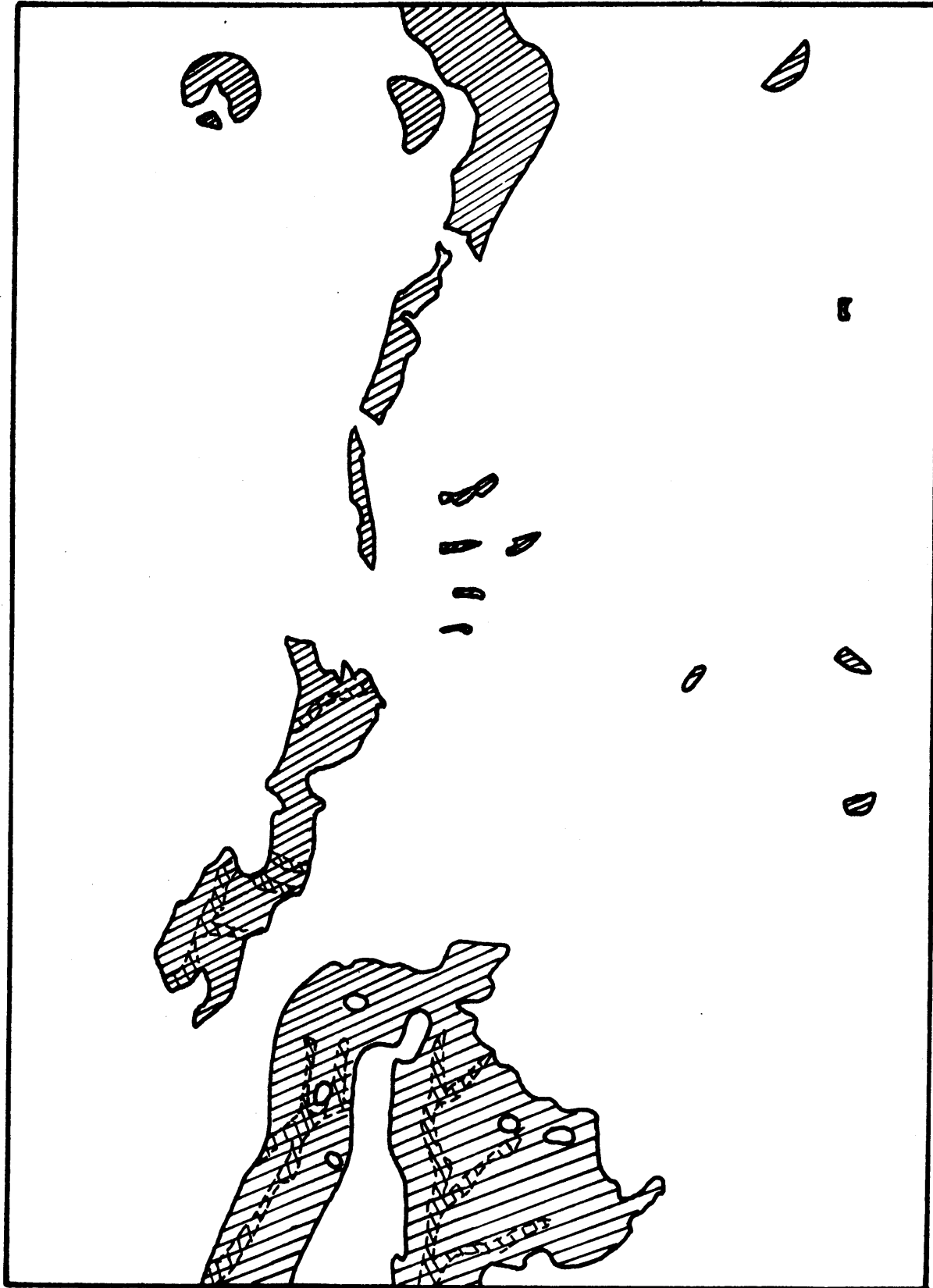

6. VEGETATION

Studies of ecosystems have led ecologists to enumerate certain ecological laws which aid with his ability to understand and manage our various ecosystems. These laws can be applied directly to the determination of buildable land within the desert biome. Briefly stated the most applicable laws are:

- a) Species diversity generally increase in ecosystems when progressing from drier regions to wetter regions and from colder to warmer regions.
- b) Species diversity in an ecosystem tends to produce stability. This implies a species diversity compatible with the environment.

As established in section 2.5 the transition zone of this region includes the most diverse vegetation. This area will be identified within the intersecting vegetation types as most suitable for building.

The following two criteria are included as the final part of this regional screening process as precedential determinants of buildable land.

7. PREHISTORIC FARMING SYSTEMS

The existence of a previous self-sustaining population within one mile of a site should give a potentially buildable

Transition Zone most suitable for building



site a higher priority.

8. OWNERSHIP

This set of information, least ecological was considered to be relevant and necessary information for the final sites to have a more reasonable possibility for acquisition in some form in order to build. Of the following divisions of ownership only land designated as a national forest, and owned by the National Forest Service should be considered not buildable.

B - State
Y - Bureau of Land Management
W - Private or Corporate
G - Forest Service

The following ecological characteristics were determined not suitable for screening buildable sites due to their relative consistency within the site. There are however criteria stated which could apply to an optimum building site within the region.

A. HUMIDITY

Using the U.S. Weather Service comfort index and the optimum level of 79 (see section 2.10), humidity should fluctuate to allow the sum of dry bulb and wet bulb temperatures to near 160.



MAP 19

Ownership

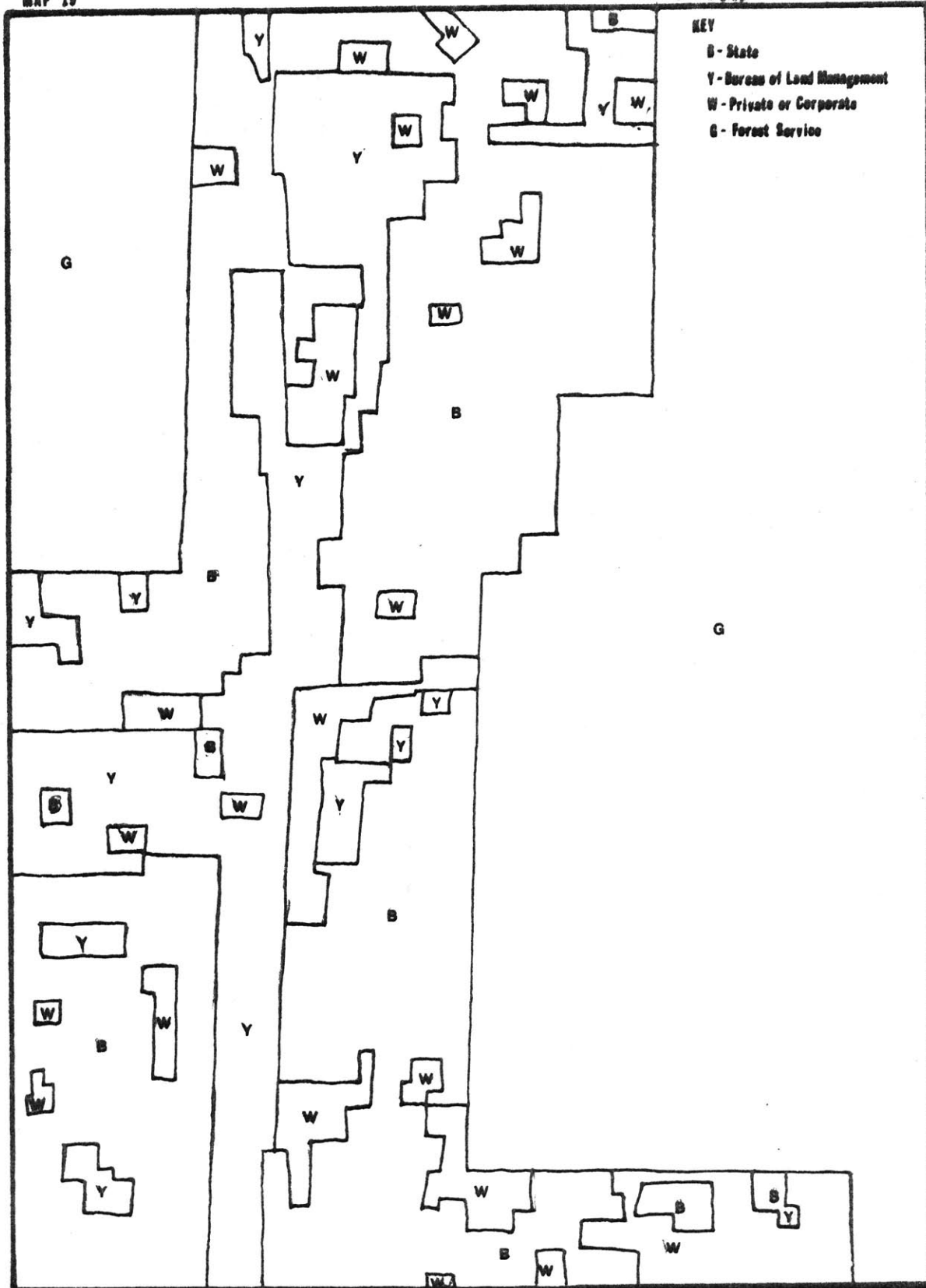

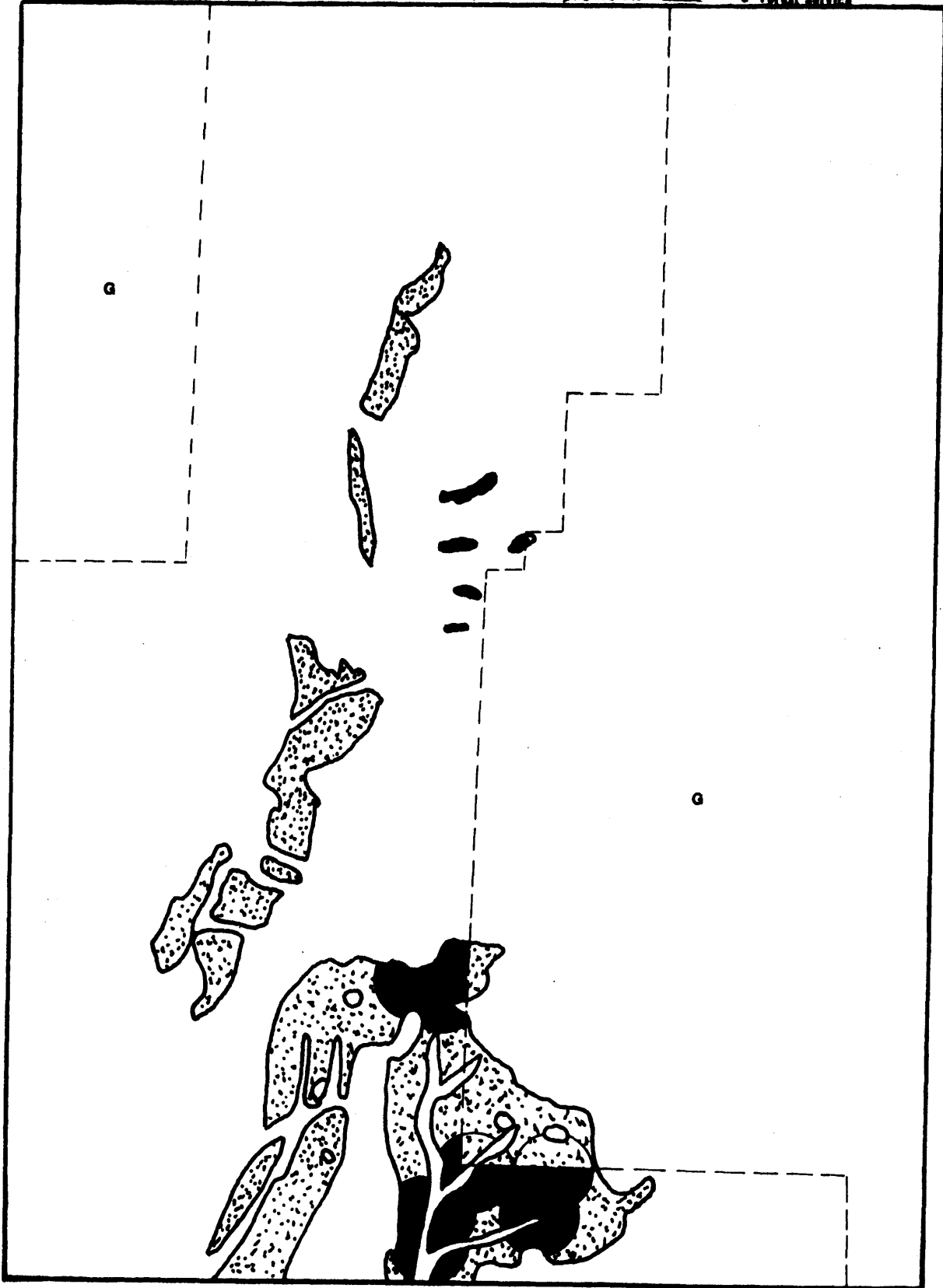

B. TEMPERATURE

Minimum temperatures should remain above freezing for vegetation and plumbing protection. Maximum temperatures should be nearest the summer comfort range of 70 - 82 degrees F.

C. RAINFALL

A third law established by ecologists states that productivity generally increases with an increase in available water providing there is sufficient energy to drive the system. Increased rainfall implies this increased productivity of a settlement if collection efficiency in different zones of rainfall is equivalent. Since the natural drainage basins and gradient of slopes which determine the volume of water available mismatch the areas of greatest rainfall, a criteria using rainfall and this law could be proven inconclusive for this site.

D. EVAPORATION

With the scarcity of water, a minimum of evaporation is obviously desirable. This is accomplished where the natural or built supply or storage is thoroughly protected from the air, sun and wind.

E. WIND

There are no identifiable areas within the site which

would have stagnant wind for extended periods of time. Stagnant wind conditions are to be avoided for both the lack of natural ventilation and the potential for inversions. Inversions, the lesser consideration, are caused by temperature increasing with altitude. Since air is a poor conductor of heat an inversion may persist for days or weeks keeping smog, which would be better initially prevented, from leaving an area where it is generated.

ARABLE LAND 3.2

Settlements have grown and prospered in arid regions primarily due to their ability to alter the natural inclinations of water for irrigation of cultivated crops. The most common source of water have been rivers that originated in areas of high rainfall and then cross arid land enroute to the sea. This water has been most often utilized by direct floodplain farming from overflows of periodic streamflows or diversion by dams within the stream. A particularly well developed example of this technique was performed by the Hohokam on the present site of Phoenix who dug hundreds of miles of canals to utilize the water of the Salt River.

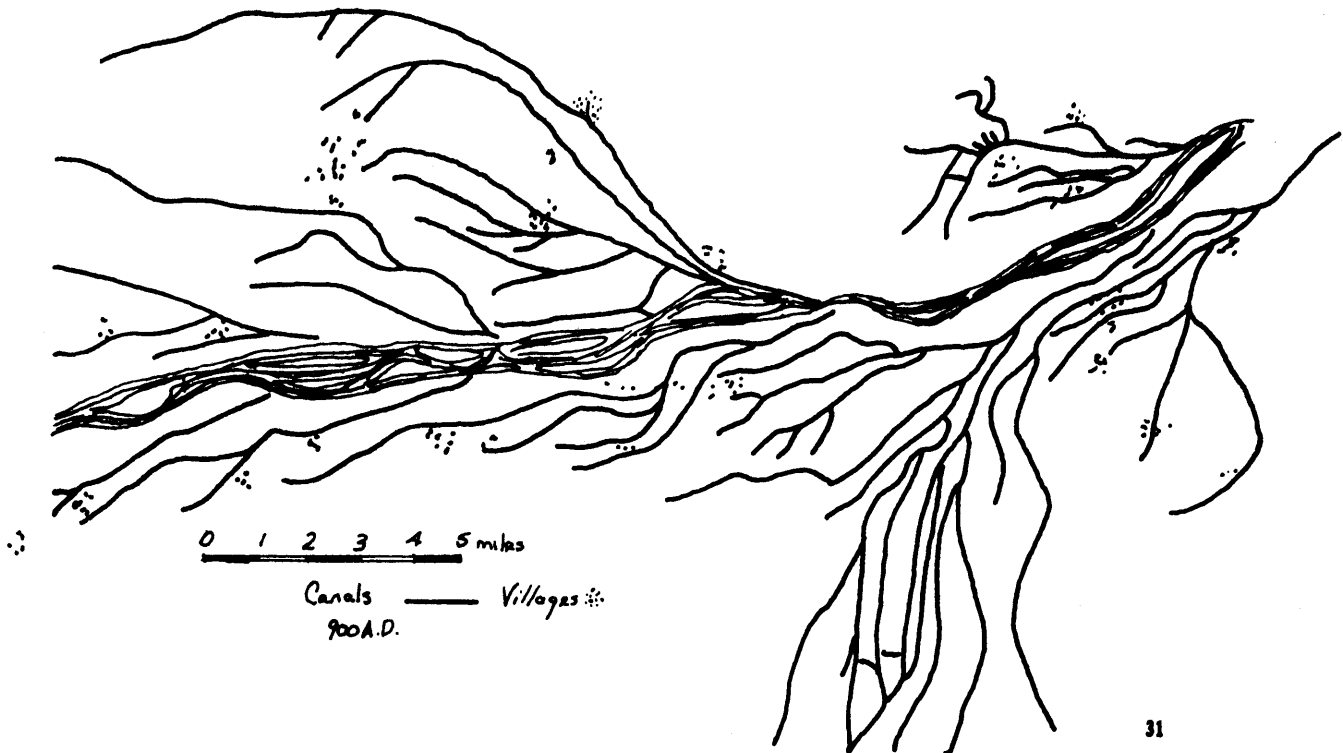

Another major source has been groundwater. Groundwater may originate in natural aquifers as illustrated in figure 33 at varying depths. This cross section is not of the site but of land in northeast Arizona. One crucial factor which may account for the lack of Phoenician expansion into this site is the lack of subsurface water in general north of bottom land (fig. 15) Some bottom land occurs in the

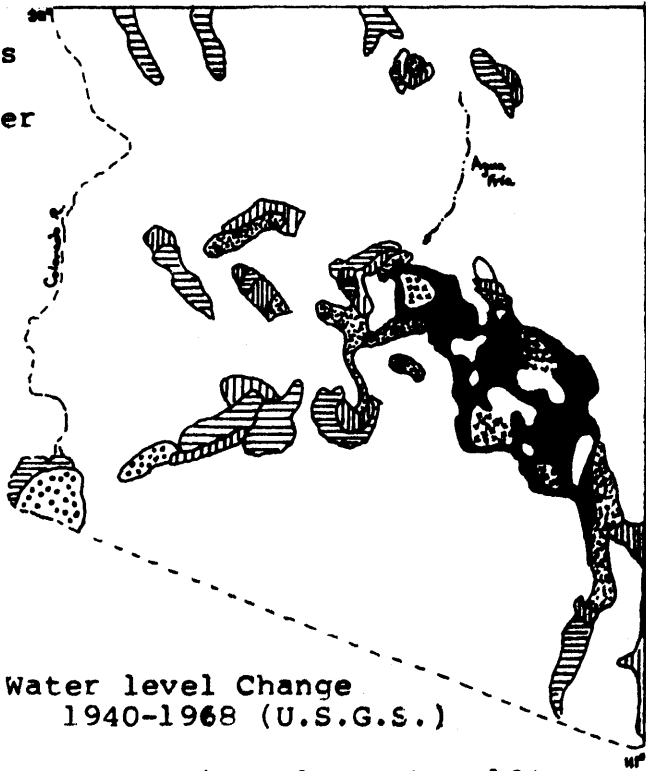

Water level Change
1940-1968 (U.S.G.S.)

	rise, less than 10'
	drop, less than 10'
	10-25'
	26-75'
	76-125'
	more than 125'

site adjacent to the Agua Fria and New Rivers accounting for the groundwater obtained at Black Canyon, New River and Rock Springs (map 1). A few innovative techniques for obtaining groundwater beyond surface depth at a minimum energy level can be seen in the deserts of Algeria and Morocco (figure 34). In central Arizona at the heart of bottom land country where Phoenix rose from the dust to become the ninth largest desert city in the world, groundwater levels have been dropping at alarming rates, some more than 125 feet, due to the continuing trend of pumping at a much higher rate than replenishment. Certainly if the ground does

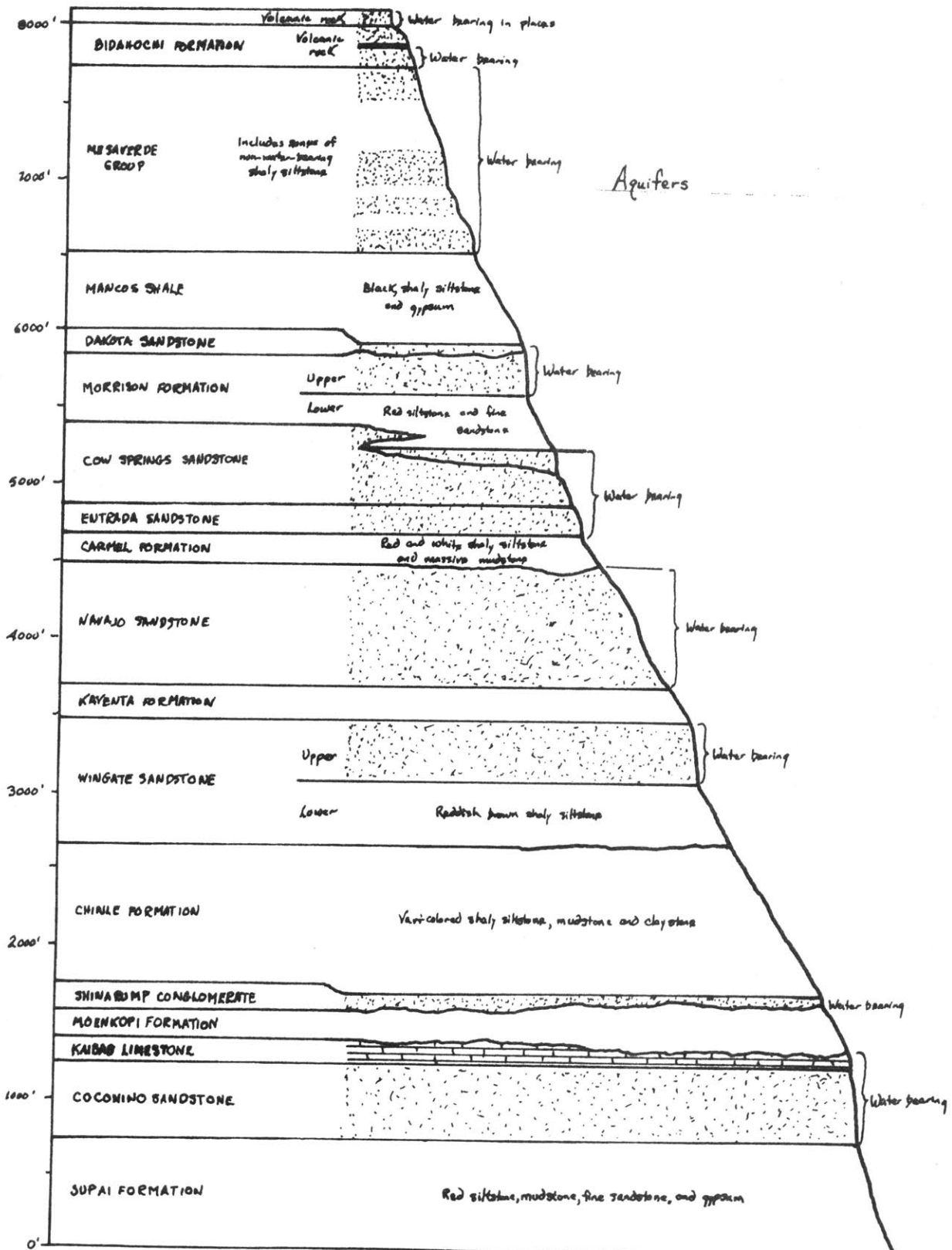

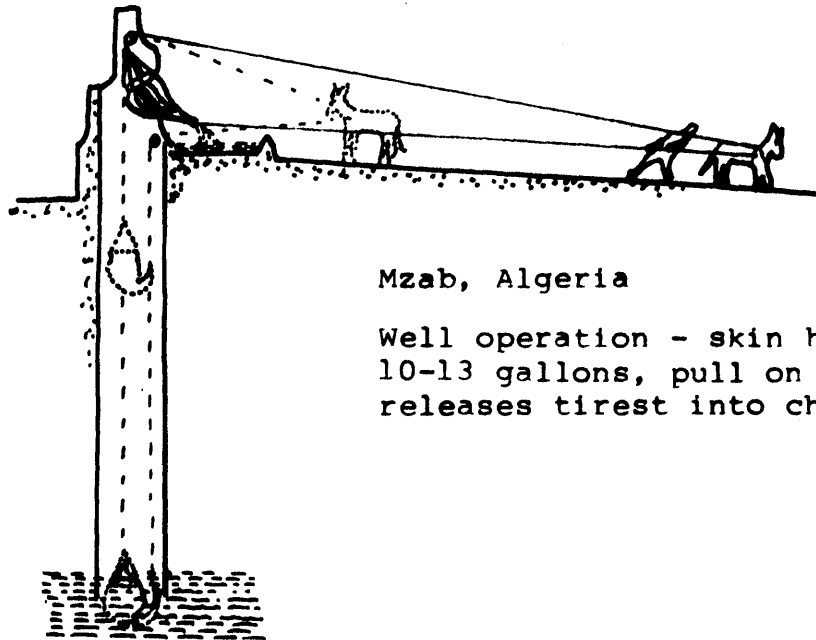

Mzab, Algeria

Well operation - skin holds
10-13 gallons, pull on cord
releases tirest into channel

not subside due to the
tremendous pressure differential
created the supply will simply
run out. In response to the
demand a water canal has been
under construction to bring the
Cororado River water more than
500 miles in open channels
through the desert to Phoenix
and Tucson. Despite wishful
thinking to the contrary
there is always some limit to
which groundwater pumping can
occur without depleting the
aquifer particularly where
replenishment occurs at a slow rate.

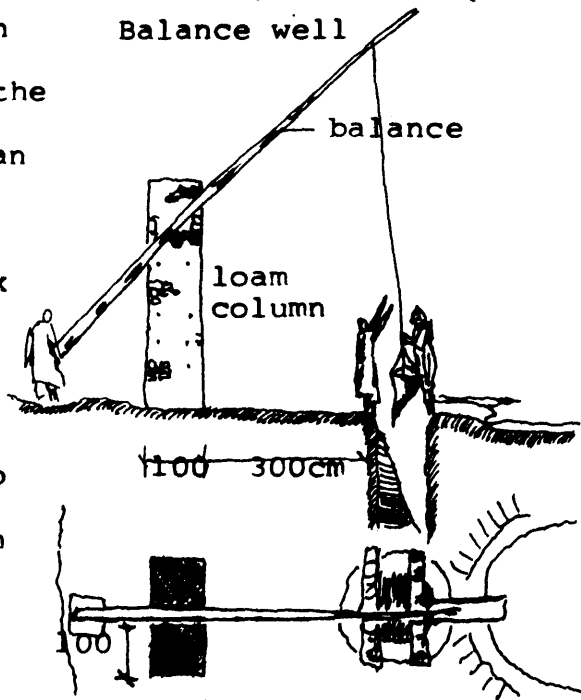
Lektaoua, Dra Valley Morocco
Balance well

An extremely critical problem in the use of irrigating water is the quantity of salt existing in the water which will build up within the soil or commonly to the root zone of plants inhibiting growth. For example, the sought river water of the Colorado contains over one ton of salt per acre foot. In order to conserve the available water and to prevent the buildup of salt a system of underground discharge and drainage above an impermeable layer can be used. Further the now saltier water can be reused by distillation in an evaporation pond.

One method to supply a quantity of potable water directly from runoff is to use a three strata filtration system as diagrammed in figure 36. The bottom stratum in contact with the natural soil would be an impermeable barrier such as dolomite clay or a polyethylene sheet. The next stratum 6 foot thick would consist of fine sand capable of passing a standard no. 20 sieve but retained in a no. 100 sieve,

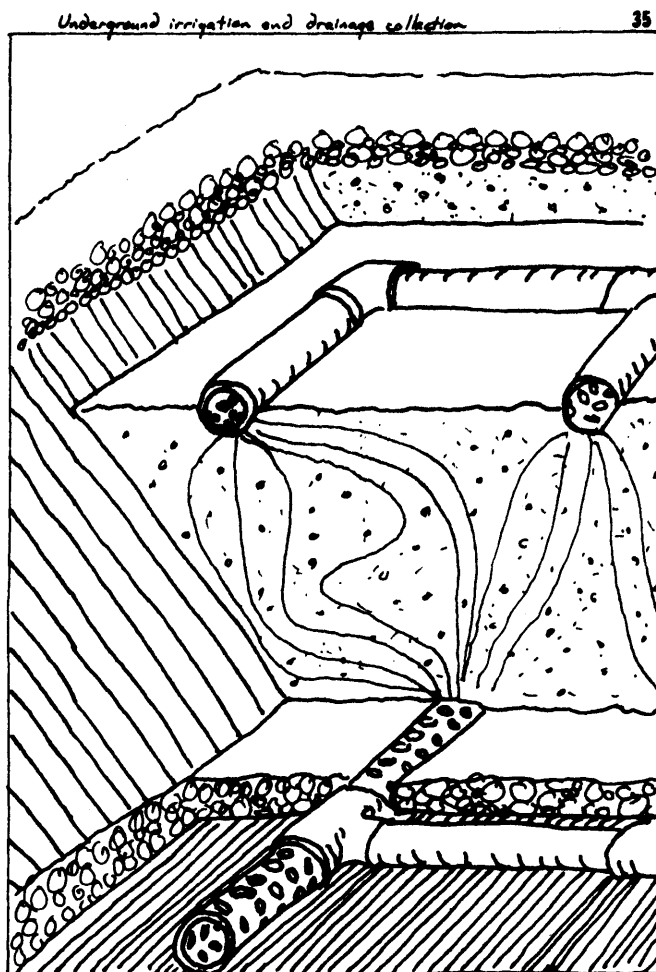

Typical plan-profile of strata for entrapment
filtration and storage of runoff for
production of potable water

if $a=4'$
capacity 70,000g

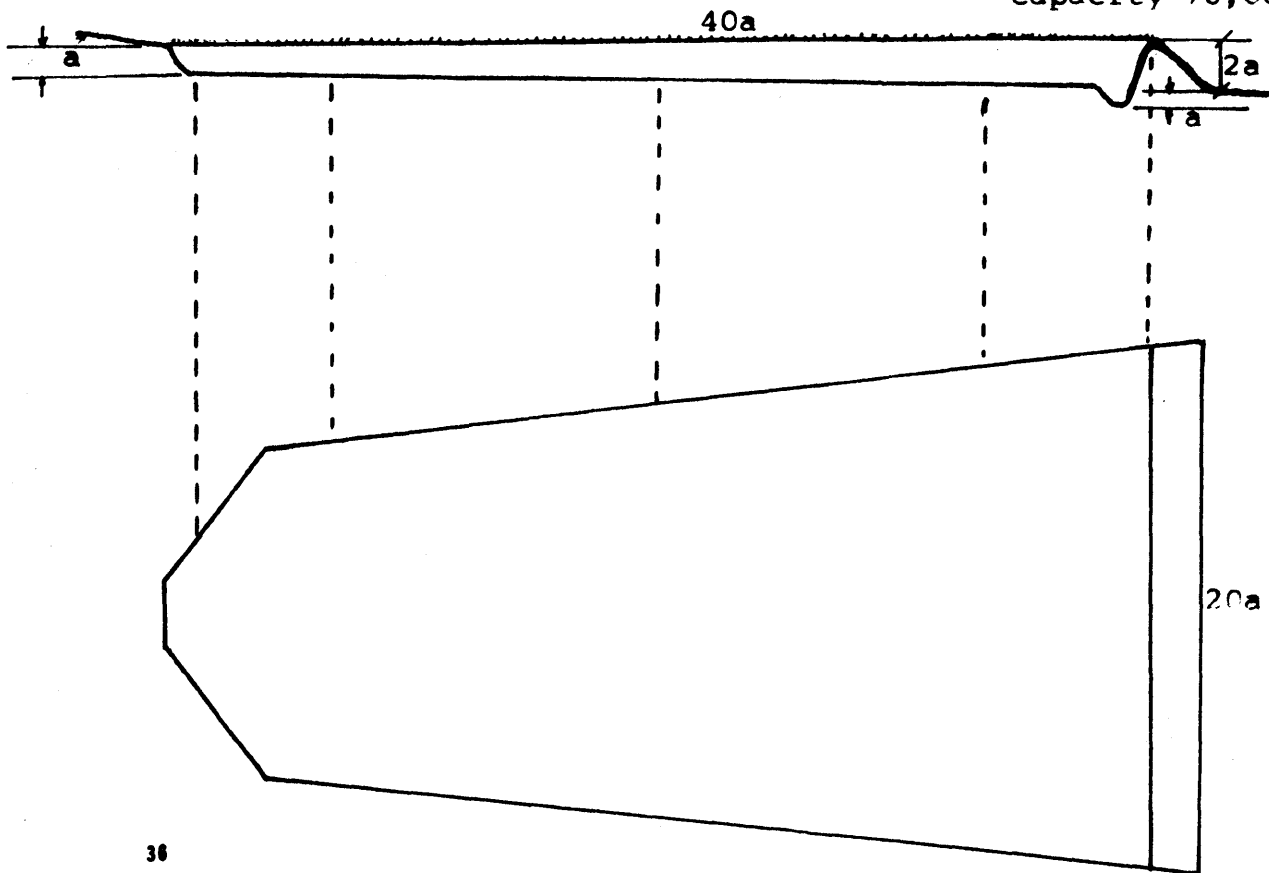

for filtration and storage. The top stratum 2 to 6 inches thick would consist of coarse aggregate to allow rapid infiltration and greatly reduce evaporation of water. This system installed in the Ramah Navajo reservation, located in west central New Mexico within the same latitudes as the evaluated region and equivalent climate, provides continual drinking quality water at the rate of 1 gallon per minute continually, with a maximum outflow between three and six gallons per minute.

The qanats of Iran, invented about 3,000 years ago by

Persian engineers are an ingenious solution to obtain water in an arid area. They consist of underground tunnels located usually in the upper portions of an alluvial fan to intercept the water there and then carry it by gravity flow

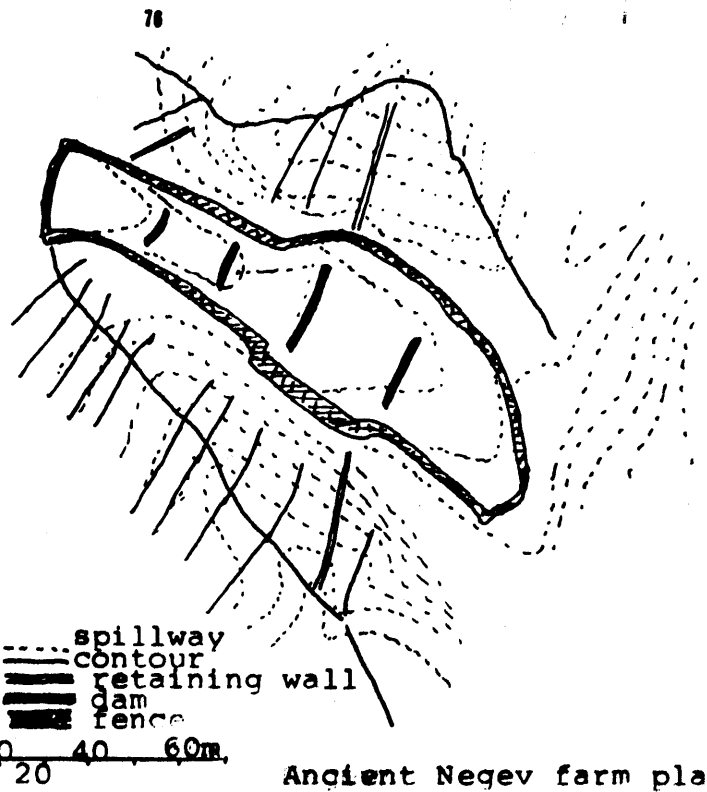

to lower elevations. The practice performed by numerous other countries to this day (Pakistan, Iraq, Syria, Sicily and Spain) is sound and can be constructed with small diameter pipe using a horizontal drilling machine.

Outdating the qanats by at least a thousand years is the principles of runoff farming. Extensive investigation into the Negev Desert of Israel has shown complex systems of diversions of water from large watersheds to terraces bordered by stone walls in the bottom of wadis (equivalent to arroyos). The system was usually designed to provide water to the upper fields first, excess water, if available, would then run over to lower lying fields. A diagram showing placement of dams and diversion walls is shown in figure 37.

As explained in more detail in section 2.12 runoff farming was also the principal method employed at various locations in this region.

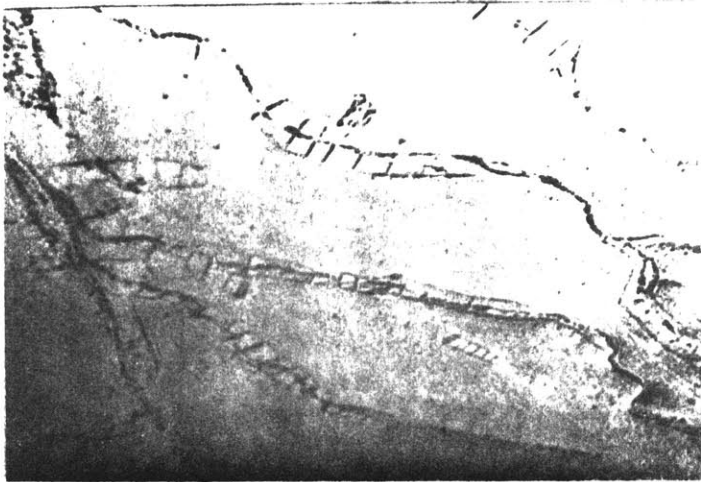

Runoff farming - Negev Desert, Israel

38

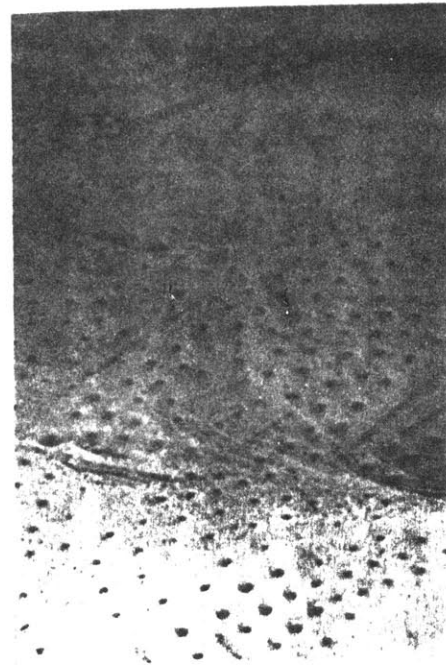

39

Figure 40 is a nomogram showing the effect of size, shape and stone cover on annual runoff in relation to annual rainfall. For watersheds (10 - 300) hectares, follow from the appropriate line in part A to the 'watersheds 5-20% slope' line in part B and then continue to part C. The upper portion of part C is natural cover, the lower, stone cleared. For microcatchments (less than or equal to 0.1 hectare), follow from the microcatchment line in part A to one of the three microcatchment lines in part B, and then to part C.

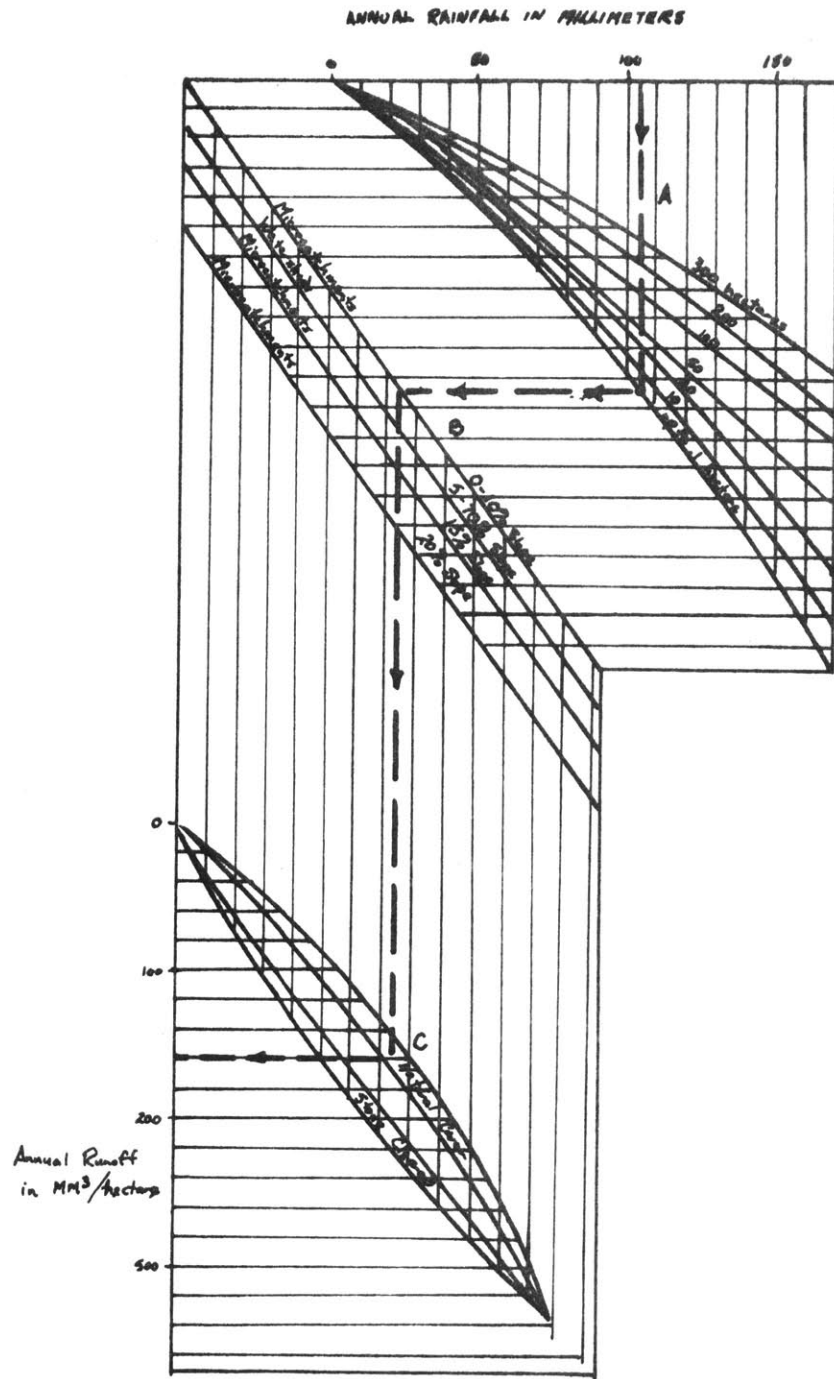

The Effect of Size, Shape and Stone Cover
for Runoff of a Catchment

All plants need light, air, water, food and support for their roots to produce harvests. In hydroponics, environmental conditions best suited for growth are sought. In replacing the earth for support by other growing media such as the simple household hydroponic trough, figure 41 the plants are nourished in solutions of water and

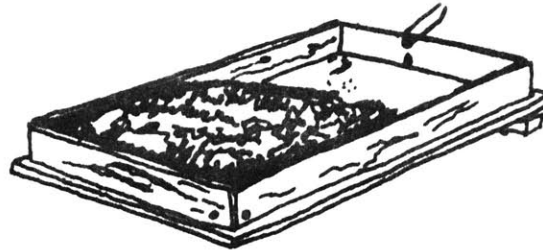

Simple Hydroponic trough

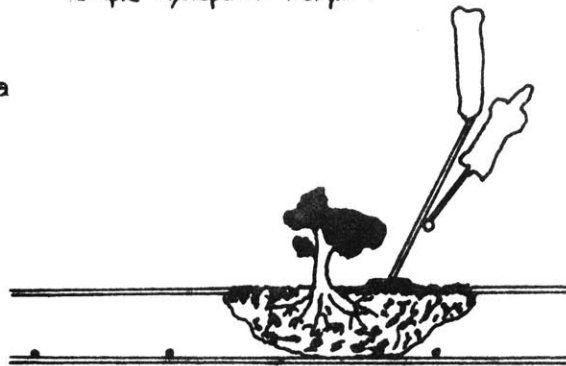

fertilizer. The illustration shows how the nutrient could be supplied, the fertilizer mixture being sprinkled evenly over the surface of the soil and then watered in. Once dissolved the nutrients can supply the plants' roots with food. An advanced variation of this technique employs high humidity greenhouses consisting of a combination of two 30 meter long, 6.9 meter wide half cylinders of polyethylene connected front and back by concrete tunnels. The greenhouse must be entered through air locks to avoid loss of the close to 100 percent humidity. A primary one-sixth horsepower centrifugal inflation blower maintains the small positive pressure of .01 to .02 psi depending on wind velocity required to keep the envelope taut. Two existing systems of this type have been installed, one in Puerto Penasco, Mexico

and the other in Abu Dhabi on the Arabian Gulf. Both produce vegetable yeilds from three to thirty-nine times the average yeild per hectare of U.S. field crops.

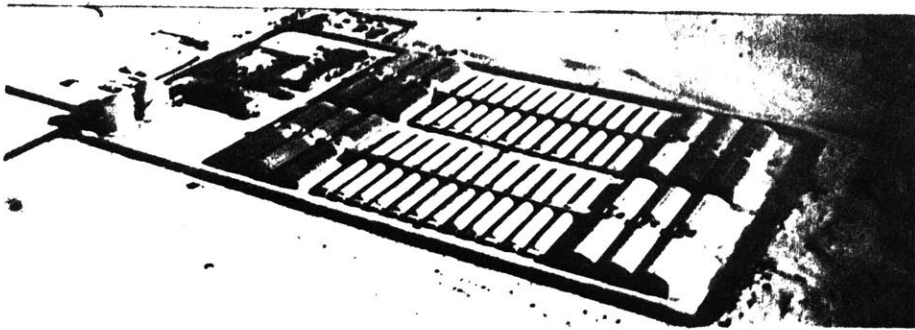

Abu Dhabi

42

The range of possible methods gives a basis for relating the characteristics of this region to the needs of arable land. Following the appropriate characteristics are given in a selected priority for determining the most suitable arable land in this region.

1. WATER SUPPLY

The most critical element for cultivated crops is the existence of water. Since there few sites in this region suited for groundwater pumping, a historically proven limited option for this region, existing runoff basins and

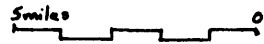

MAP 21

Land within one-half mile of a water supply

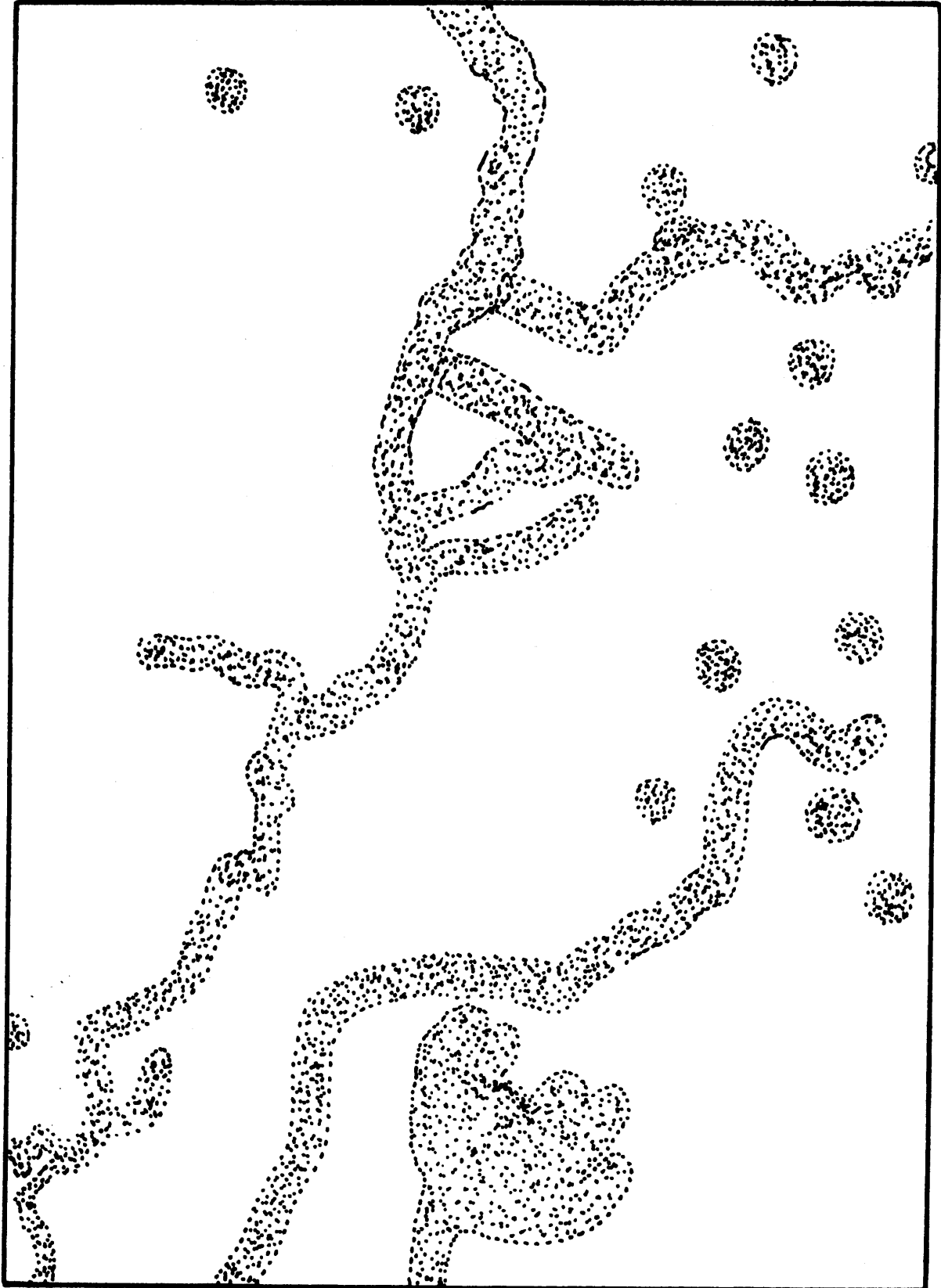

springs should be used to supply water. Using the regionally determined precedent set by the prehistoric farm plots, the maximum distance of arable land to this water supply will be one-half mile.

2. SLOPE

An influential selection criteria for arable land is the orientation of slope to the sun. Since the maximum yearly radiation is to the south, orientations of south, southeast and southwest are identified as most suitable.

3. SOIL

The Reddish Brown, Calcisol and Grumsols of this region are very fertile. The granitic soil will be eliminated as least fertile.

4. GRADE

Many of the methods discussed of supplying water to land for cultivated crops have a specific grade in which the method can be employed and a most efficient grade. For example, the tolerance ranges for irrigation and terracing respectively is .1 to 10 percent and 5 to 35 percent while their most efficient grades are 1 percent and 12 percent. Grades of less than 30 percent will be selected as most efficient arable land.

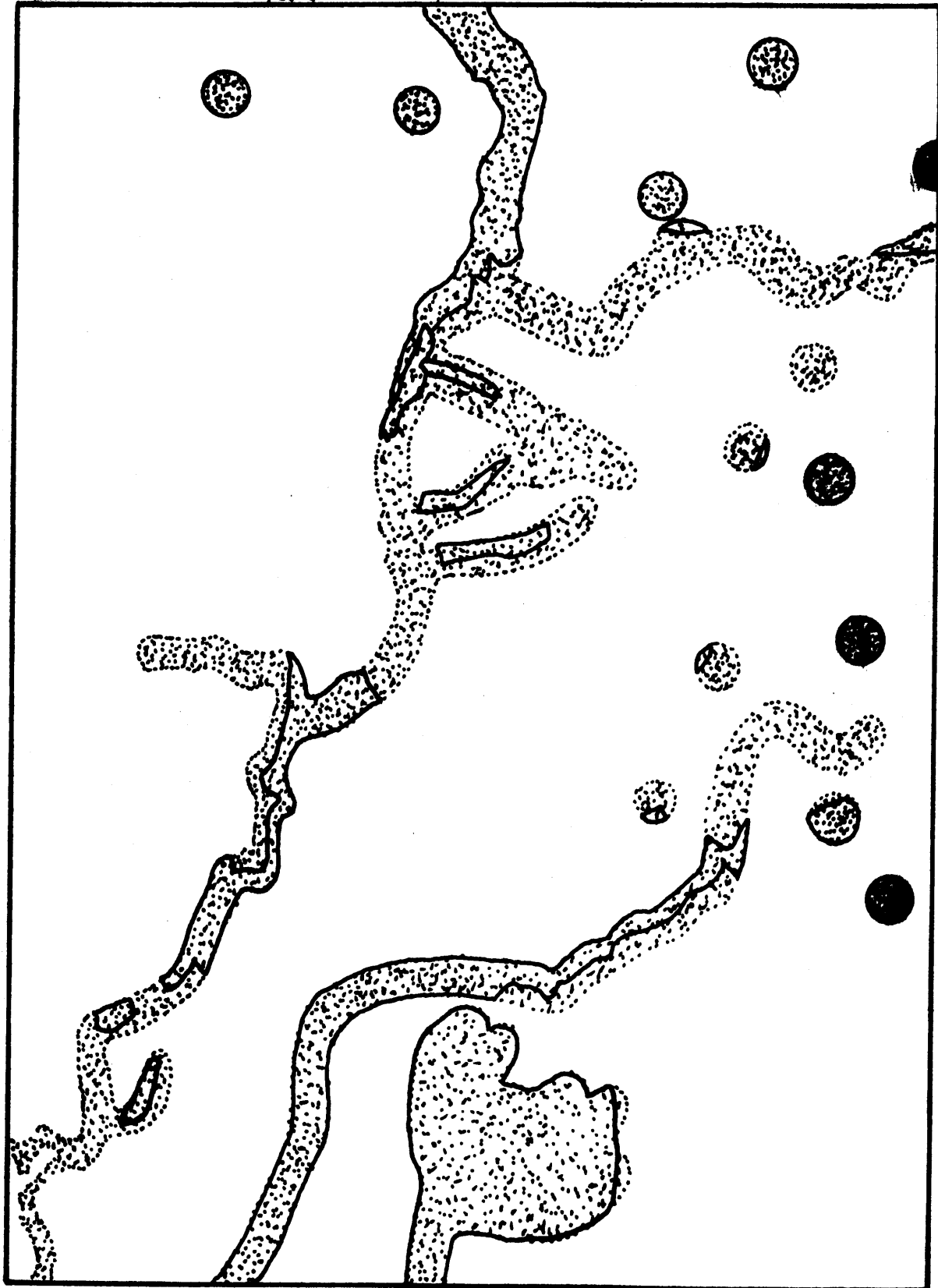

MAP 23

84

Granitic soil eliminated

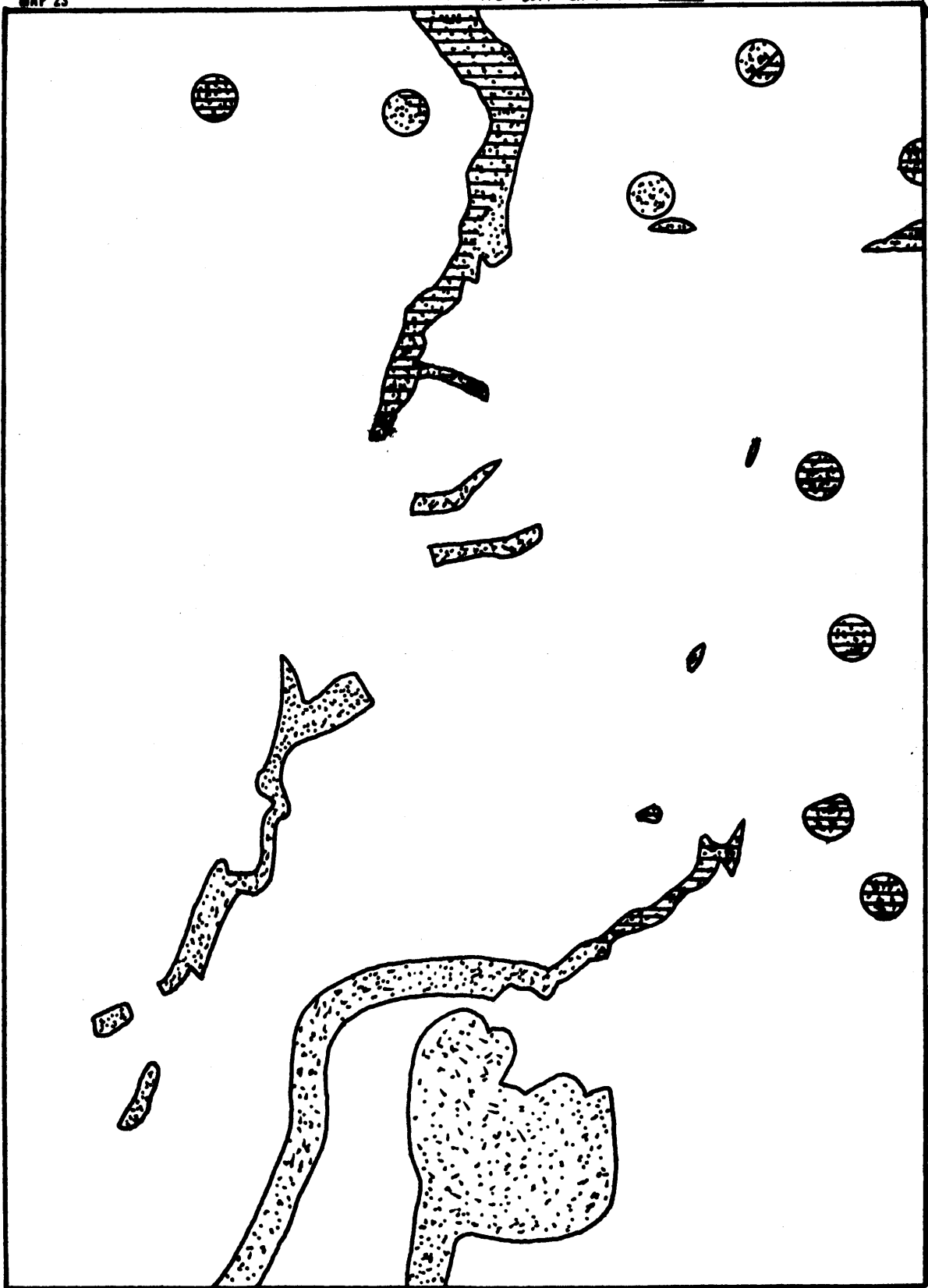
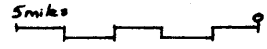

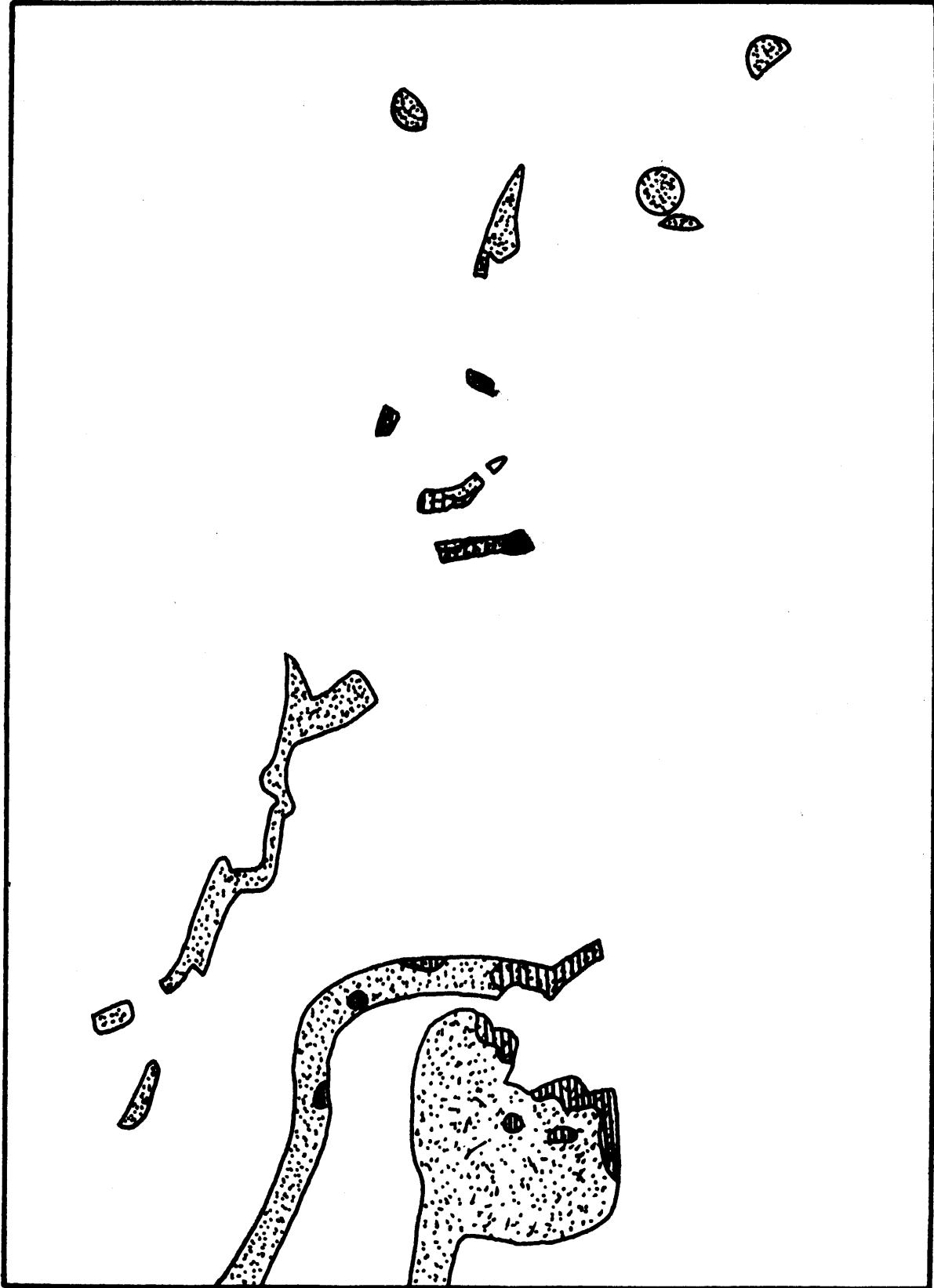

5. VEGETATION

The difficulty of providing adequate radiation exposure and clear ground in the areas of coniferous forest designates this area as least arable.

6. GEOLOGY

Areas of this region which have a predominance of granitic or metamorphic rock have the least probability of allowing adequate drainage and water retention for an arable site.

7. BUILDABLE LAND

The information of potential building sites should be included as a final sieve in selecting sites for arable land. The precedent limit of 1 mile was set by the maximum distance between the prehistoric farming plots in this area and the adjacent dwellings. This range will select the arable lands within one mile of buildable land.

The characteristics of rainfall, temperature and humidity are not suitable for determining arable land because of their consistency. The importance of low surface wind velocity though critical for decreasing evapotranspiration, cannot be evaluated for site selection at this scale.

MAP 25

87

5 Miles 0

Granitic or metamorphic rock

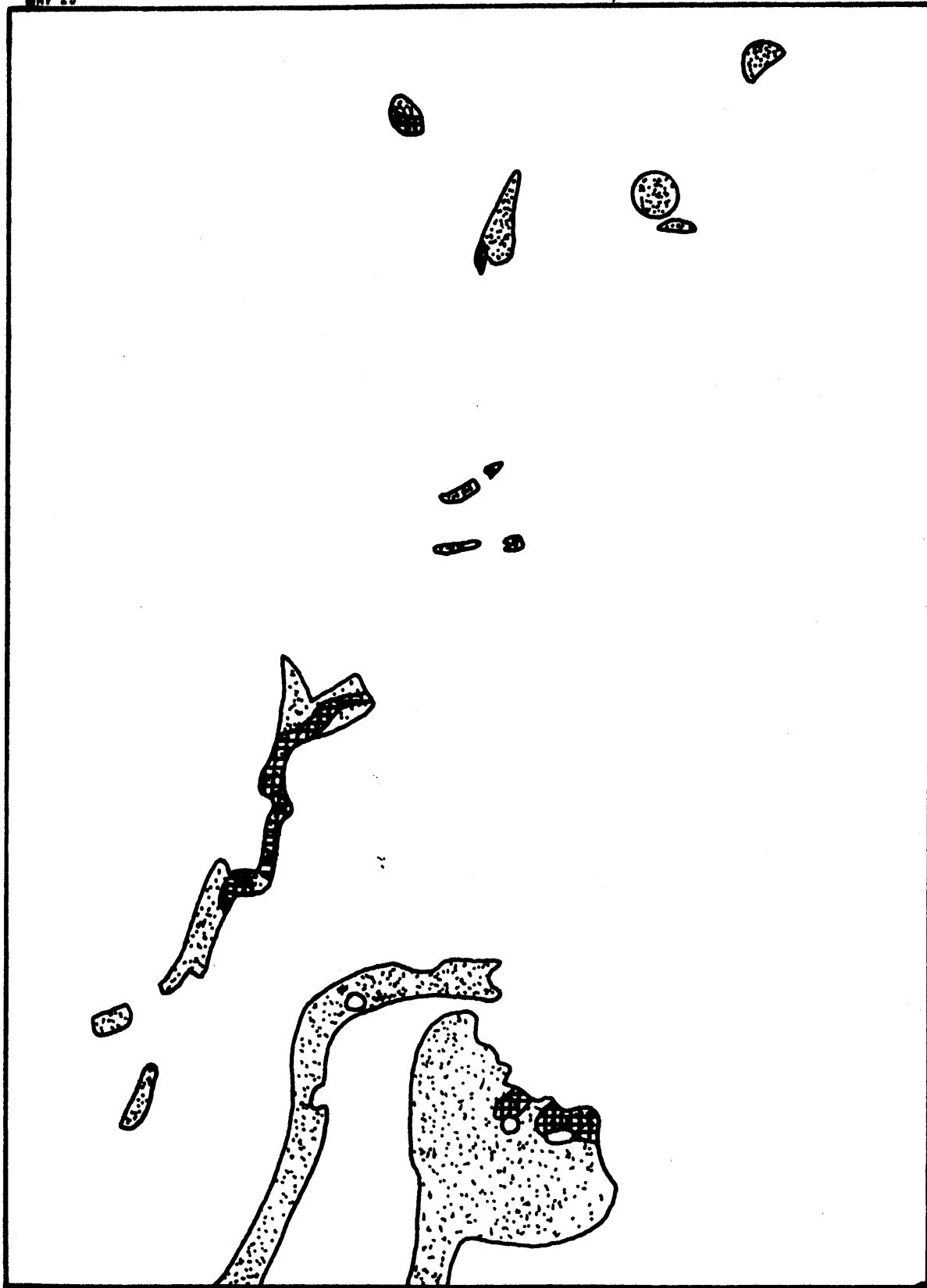

MAP 26

Arable Land

Arable Lands within 1 mile of Buildable Land

5 Miles

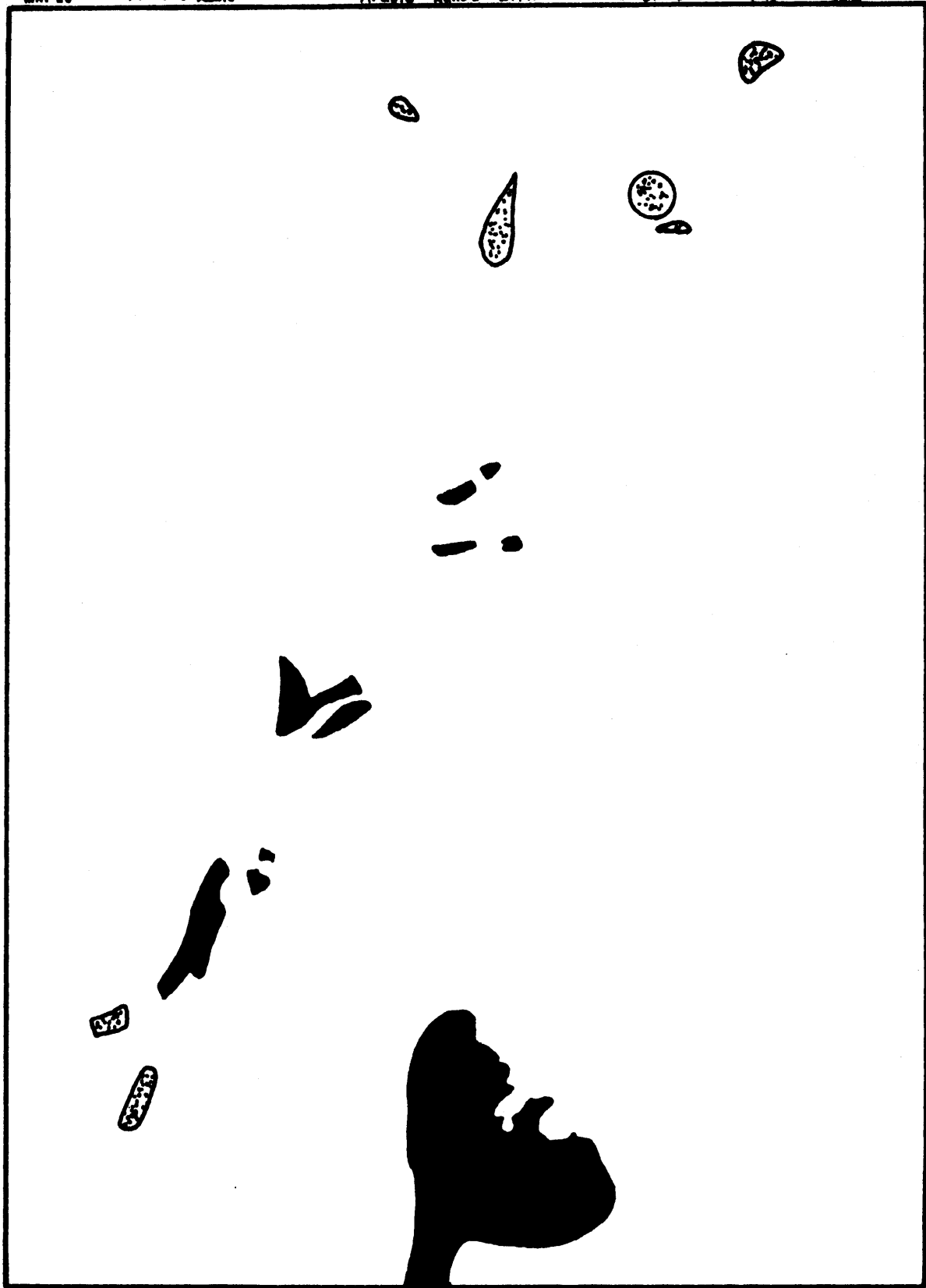

SETTLEMENT SIZE 1.3

The size of a settlement should be determined by evaluating the specifics of the scarcest resource for a buildable site. A resource is defined for this study as the means to meet a need of a population. The singular needs considered here are those of human comfort, food and water. The range of human comfort used is the range given by Olygay's bioclimatic chart (see figure 22) and the comfort index (section 2.10). Average dry weight food intake is defined as one-half pound. Average water intake and use is given as three gallons per day. Of these needs, food and water are the most critical and since food does not exist in any abundance in this region naturally and must be cultivated by water or imported, the scarcest resource is water.

The drainage basin data for this region from table in section 2.7, gives yearly surface runoff for basins in this region. Next to the continual use of the same body of water which is next to impossible to achieve, the most ecologically balanced means of water supply is partial use of surface runoff. Using approximate percentage length of tributaries of these basins as the percentage of runoff from the basin total, the available water can be determined for sites adjacent to these tributaries.

Water is used both for human drinking, washing, cleaning

cooking and the cultivation of crops. Since a potential settlement should be planned to supply its own food, water must be provided for both uses. Since the average hectare can produce twenty thousand pounds of produce per year with runoff of 5,520 cubic meters of water (1,458,660 gallons) the relative need of water between crop production to human use is approximately fifty to one. Using these two variables, a maximum settlement size can be determined for a specific location along a tributary of one of the drainage basins identified in this region. From this data I constructed an equation for determining settlement size:

$$\text{SETTLEMENT SIZE} = S = \frac{\frac{R \cdot T}{F \cdot W_h} + W_p}{Y}$$

where S = settlement size, number of citizens
 W_h = water required per hectare in gallons per year
 F = food required for one citizen per year in lbs/year
 Y = yeild per hectare in lbs/year
 W_p = water required for one citizen per year, gal./year
 R = basin runoff in gallons per year
 T = length of tributary, percent of basin drainage

For example using the drainage of Larry Creek (page 36, map 8), the total yearly runoff from this drainage basin is 21,200,000 gallons per year.

$$S = \frac{21,200,000 \cdot 1}{\frac{362 \cdot 2 \cdot 1,458,860}{20,000} + 3 \cdot 365}$$

$$S = 420 \text{ citizens}$$

ORIENTATION 3.4

The orientation of a settlement is primarily determined by the slope of the land. In situations where the land is nearly flat or the slope of the topography is variable it is defined as the direction parallel to the major water flow. The optimum slope orientations for buildable land previously discussed in section 3.1 are best utilized by orienting the predominant mass or axis of building perpendicular to this slope. Since any access is obviously easier along the contour of a slope than at any angle to it, this orientation coincides with the building orientation. The orientation for unbuilt space defined within the settlement for a particular use other than access would also be best oriented with its long axis perpendicular to this optimum slope, offering the optimum climatic conditions for the greatest amount of defined unbuilt space.

FORM of a SETTLEMENT 3.5

The resulting form or pattern of a settlement given primary orientation and access depends on the physical constraints of the land to be built upon. The specific building materials used will define a range of forms comprising the elements of the building not necessarily evident in the form of a settlement. These constraints can be understood by the major patterns of organization

which exist in this region as examples of form in balance. The terrain is the expression of the geological character, the vegetation and the surface geometry of the earth's crust.

The geological character of a region is a three dimensional process of change comprised of igneous, sedimentary and metamorphic rock. The surface of any area is either in the process of erosion or deposition. Alterations from this sequence are unconformities, such as overlapping contrasting stratta, folds or faults caused by tectonic activity. Geological formations apparent in this region include:

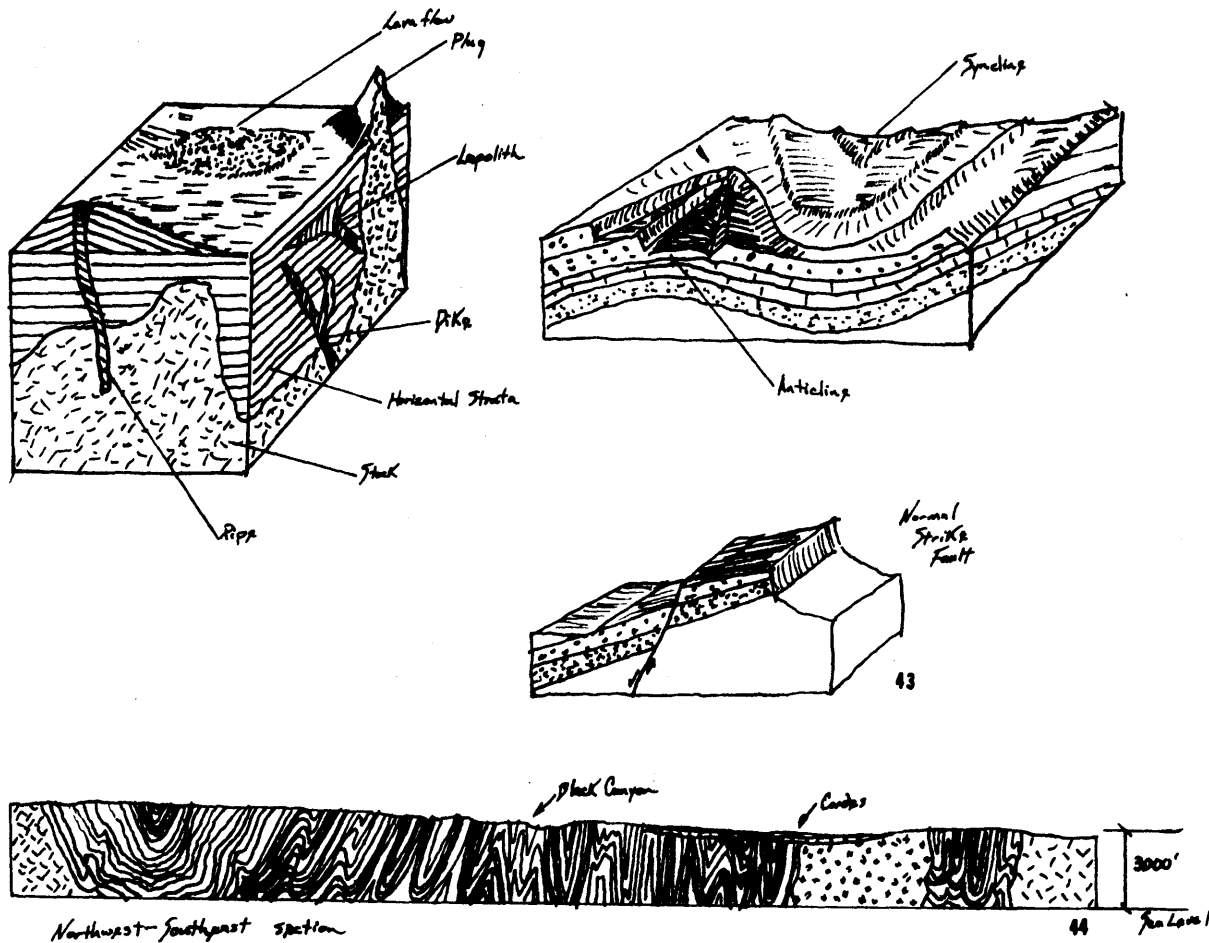

An apparent vegetation pattern exists in the interlocking edge of the mixed cactus - paloverde association as it intrudes upward along ridges and south facing slopes among species of the jojoba - false paloverde - ocotillo association, which finger downward along drainage ways.



Landscape consists of hilltops, slopes and valleys. In plan crests can be either rounded or elongated and parallel or randomly distributed giving rise to four possible distribution patterns. The two sectional viewpoints contribute the other dimension describing hills as peaks, ridges or plateau. Slopes vary in length and can be described in plan by their dendritic pattern. This region's drainage patterns as identified in section 2.7 are dendritic, trellis, and rectangular. Dendritic is the most common indicating flow through uniform materials. The trellis pattern indicates flow responding to the strikes or contours of a tilted bed of strata. Thirdly the parallel pattern is characteristic of outwash areas of low topography where the main stream may indicate a fault.

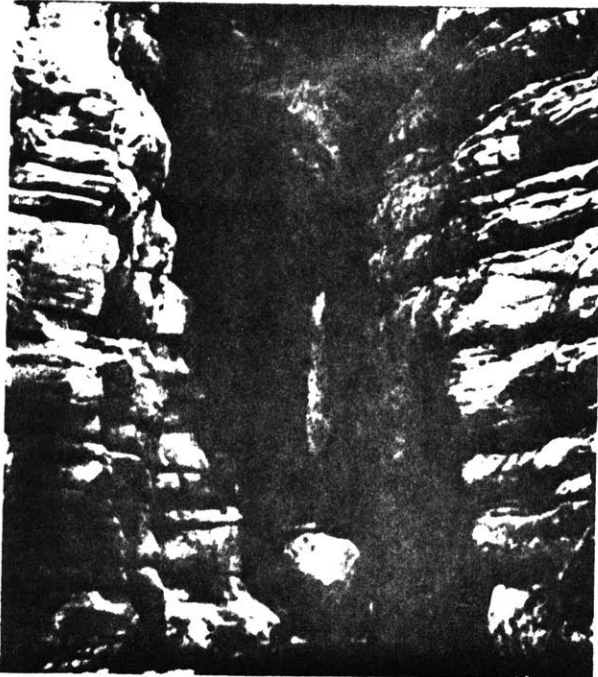

Mesa Edge / Canyon Falls

46



Aerial of Agua Fria

47

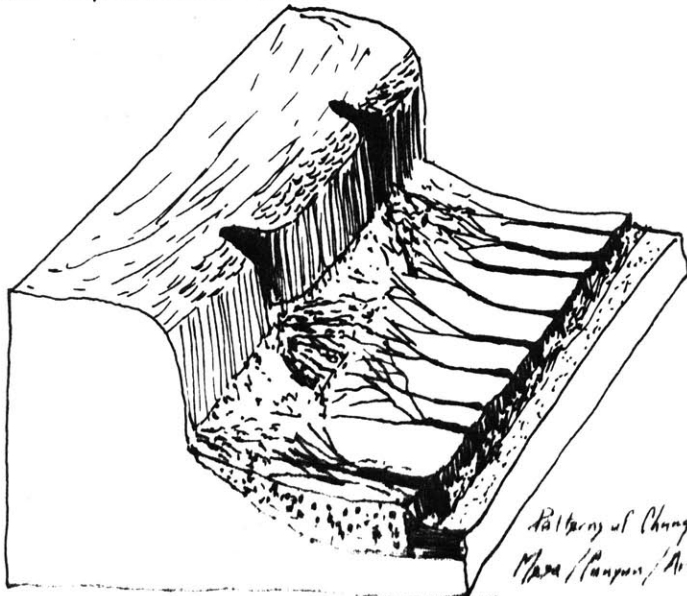

48

Pattern of Change
Mesa / Canyon / Arroyo

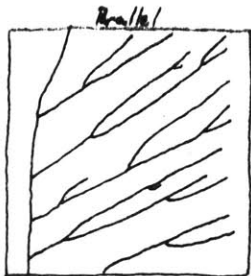
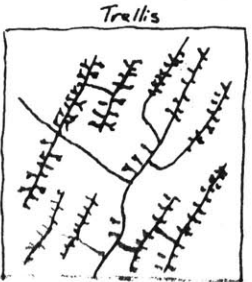
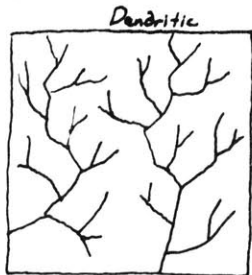

48

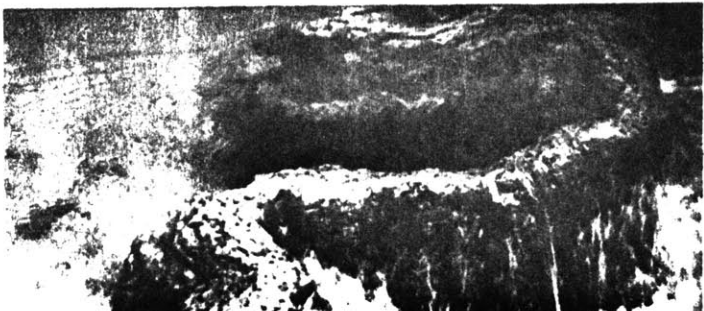

Enclosing River Path

50

BUILDING HEIGHT 11

A single building will be defined as the enclosed space, primarily protected from the weather, distinct from another enclosed space by the continuous unenclosed space, primarily exposed to the weather between them. This avoids the confusion of noting a set of separate buildings, which have common walls, floors or roofs but which require entering a street or continuous unenclosed space to enter an adjoining building, as one building.

Building height should be first understood in terms of the changes which occur with increased height. Due to the effect of less pressure resistance, wind can be expected to increase dramatically with altitude. An increase of 10 mph from ground level to thirty feet above ground level is common. With the increase in wind speed potential building ventilation and evaporation is increased. The effect of increased evaporation suggests the wet dwelling spaces protected from the wind or near the ground. Increased ventilation suggests a dry, open structure to use the cooling effect of the wind or to channel the increased wind speed to lower levels. Even if there is no wind the existence of a connection between the higher and lower elevation will cause draft due to the difference in pressure.

Secondly, temperature within a building will increase with height. A typical stratification of temperature levels

in a single level dwelling at this site may be from seventy degrees at ten feet below ground level to 140 degrees in an unvented space of light construction 10 feet above the ground. Note that the earth temperature at ten feet has the least variation providing maximum temperature of less than seventy degrees. (Why is it that the majority of all homes

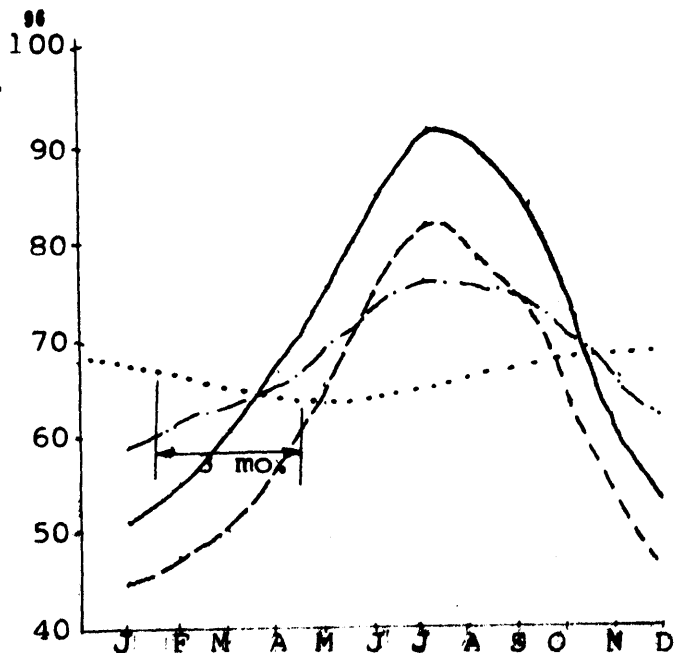

————— Phoenix mo. air temp. 33°26'N, 1117'ele.
 - - - - - Cordes mo. air temp. 34°18'N, 3771'ele.
 Earth temp. 10' deep av. central Arizona
 - · - · - est. air temp. in a court 10' deep

in Phoenix are built without use of the ground or even basements? The developers are responding to their initial first costs involved in building and selling slab on grade homes not the life cycle cooling costs of an owner.)

Additionally heat stratifies within an enclosed room. While low ceiling heights or ceiling fans bringing hot air down to use levels are advantages in cold climates, high ceilings and upper vents or clerestory windows are an advantage in this region to allow the hot air to rise away from use levels.

Shade from solar radiation is an important factor for 67% of the year. The levels near the ground have the greatest

potential for shade due to natural vegetation and topography. Besides the direct shade is the cooling effect vegetation has on air blowing into a dwelling, due to the heat removed by evaporation. Spaces above the average height of vegetation (approximately 3 feet) must rely on either the building's own screens or overhangs or the shade from a nearby building.

Minimizing energy loss through ease of access is another criteria for determining building height. While normal minimum energy settlements have built average maximum heights of three stories, the natural highs of existing topography can increase the maximum perceived height by thousands of feet.

Distance between Buildings 37

Shade for a building can be determined for any particular time by the altitude and azimuth of the sun. One condition to provide the maximum shade for a group of buildings is to put them entirely in the ground. The dimensions of a court would determine building distance if separated and no distance if interconnected. Underground building is quite appropriate for this site given the primary advantage of low soil moisture, water being the most devastating and costly aspects of underground construction. The most balanced form of this condition providing maximum density of material to all sides except from 0 to 30 degrees in section towards the south or southeast is achieved by

building or locating a cave.

In portions of the site where underground construction is not feasible due to ground conditions location in a canyon, valley or hollow in the natural topography can provide a similar advantage. On a flat site where underground construction is also not possible or adequate, the

building itself or adjacent buildings must provide the shade.

Decreasing radiation penetration by depth, adjacent buildings or partially built space in section or in plan, possibly only allowing a distance to afford a walking access creates the advantage of cool exterior environment in addition to decreased gain of interior spaces. An important consideration in the design of a narrow access space is the wind channelling effect

caused by long stretches of a single passage. Obstructions at both ends or alternatively a passage with frequent minor deviations in direction will decrease this effect.

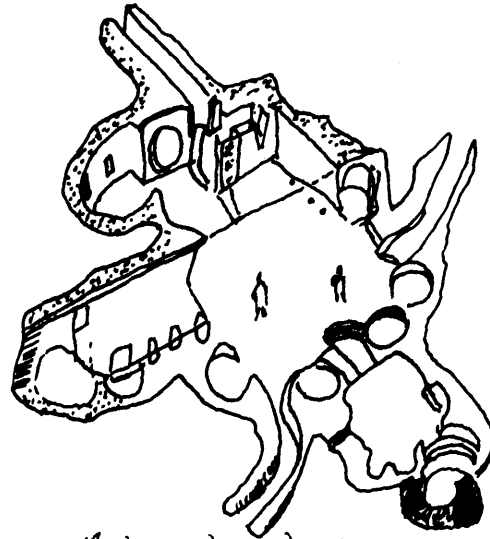

Macedonia, underground city

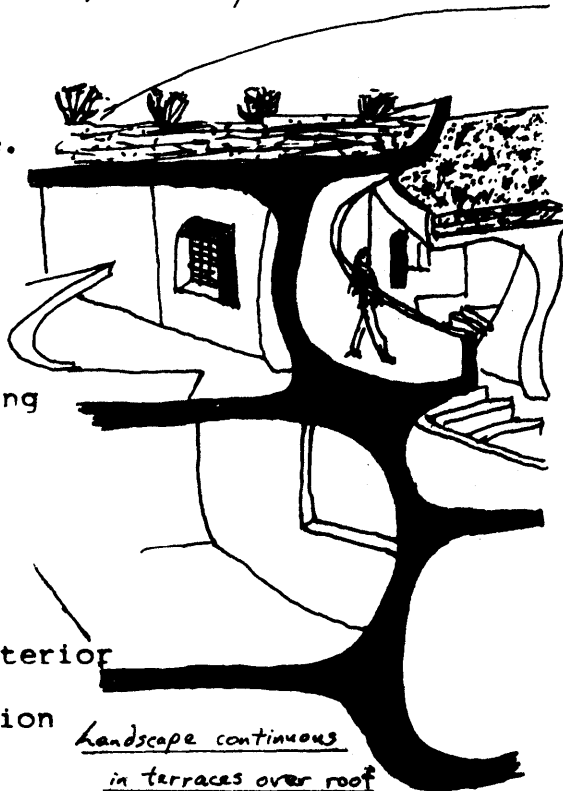

Landscape continuous

in terraces over roof

Concrete cast over
carved earth

POWER

Power is the rate of work.

In physics the language is equivalently stated as the energy transferred per unit of time.

The sun is the essence of all power on the earth. All sources can be traceable to the sun. The most prevalent source of power to do anything on this site is the sun. The winds created by differing pressures caused by the sun's heat and the rotation of the earth, probably caused by the sun at one point in time, are a second force.

An evaluation of wind speeds in locations at airports bordering this site reveals an average wind of less than 10 miles per hour.

From a theoretical maximum power extractible from the wind $P = .59KA V^3$

- K = .5 density of air, 53×10^{-7}
- A = Area of turbine in $ft.^2$
- V = Velocity in mph
- P = kilowatts

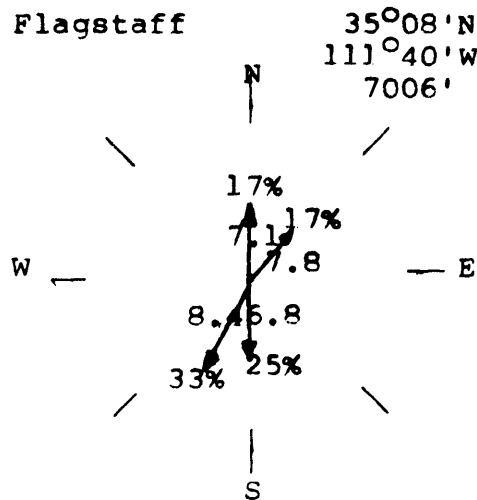
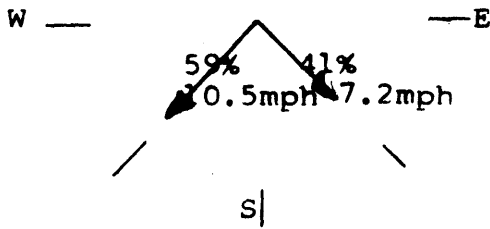
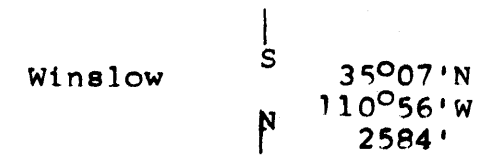
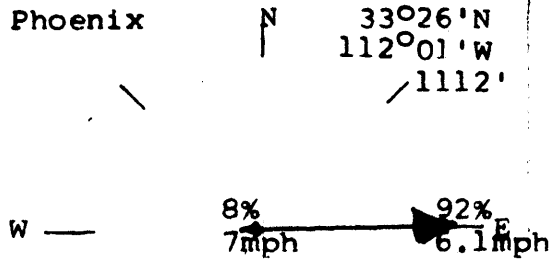

Maximum power from various diameter
windmills (kw)

mph	6ft.	10ft.	12.5ft.	25	50
10	.028	.121	.38	1.5	6.0

Equivalently a 6 foot blade could supply enough wattage for 4-60 watt bulbs. Obviously an average wind of six to seven mph will not supply much power.

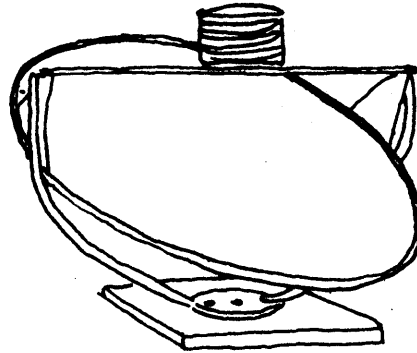

55

Solar radiation is collected simply and cheaply by plants used in photosynthesis but the process is not very efficient in terms of the incoming energy converted. A more efficient use is the application of the energy as heat or more rarely into a direct conversion to electricity. The energy may be focused to create high temperatures or at low temperatures by allowing the materials to heat up which are exposed to it.

(A solar furnace in the French Pyrenees focuses radiation by moveable mirrors to temperatures above 3000°C. On a smaller scale a parabolic cooker or reflector oven does the

Water Pumping

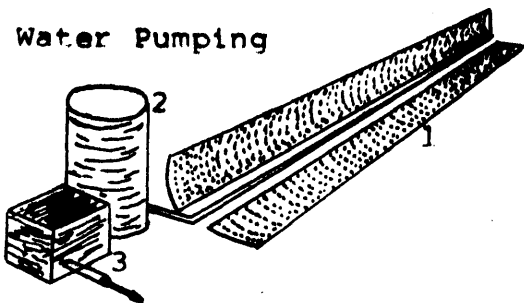

1. Double-Cusp Collectors
2. Hot Water Storage
3. Turbine/Pump

same by a fixed panel or set of panels. Similar geometries with more extensive application include fixed paraboloid cusps, hemispherical bowls and a variety of combined mirrors and lenses to focus radiation at a common point

56

or set of points along a line. This focus is often directed to a pipe carrying water which when heated will provide hot water or steam. This hot water or steam can be stored or used directly to drive a turbine. The turbine, the least efficient link in the process (20-33%) can in turn drive a water pump as a means of transferring water to a higher location of use or as a potential source of energy. As a means for supplying electrical power the turbine would drive a generator, 90% efficient. The type of concentrators used in this application would be of the high temperature type, either the hemispherical

Refrigeration

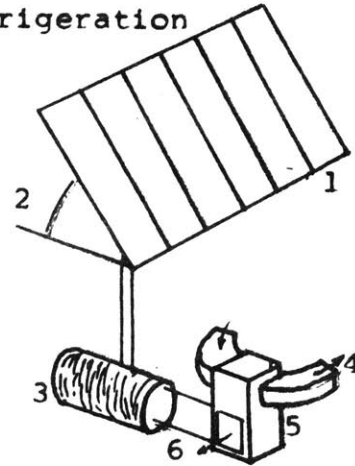

1. Solar collectors
2. Angle equals lat. for max. summer gain
3. Heat storage
4. Refrigeration
5. Gas-Absorbtion
6. Excess heat

57

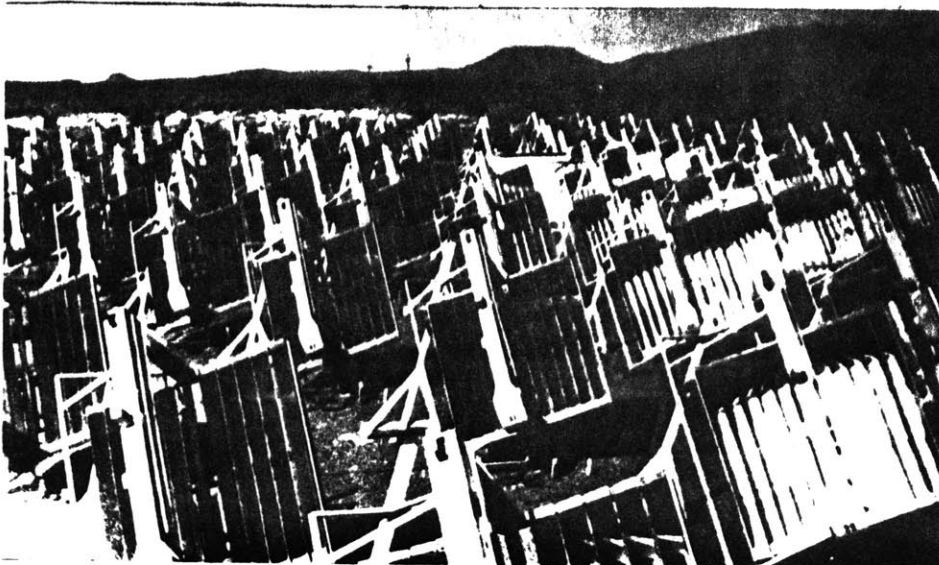

Field of Heliostats New River, Arizona

58

bowl or a field of heliostats focusing on boilers. Aside from these concentrating collectors' complexity of construction and maintenance is their requirement for transferring heat through a turbine before generating electricity. One alternative is to provide fixed concentration of radiation onto a silicon cell to produce

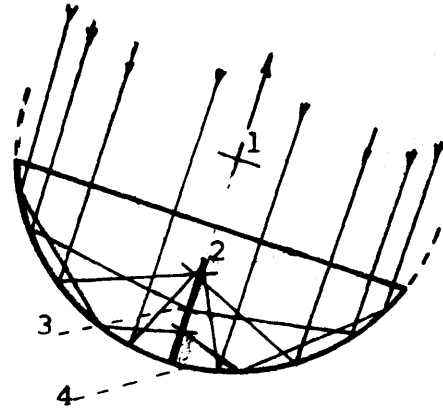

Hemispherical Bowl Collector

1. Center of Curvature
2. Paraxial focus
3. Absorber
4. Spherical mirror

both electricity and hot water. The size and installation would be comparable to the flat plate collector. The installation and size of such units, (such as now made by QED Energy Systems, Cambridge), is similar to flat plate collectors offering the dispersal of collection and distribution more in balance with the diffusion of the source and its ultimate users. The illustration of a gas absorption refrigeration system includes flat plate collectors which could easily be replaced by the hot water produced by the heat transfer from a silicon cell. The refrigeration system would not be intended for space conditioning, which is completely achievable in this region by passive design, but rather for food preservation.

Organic Waste Treatment .,

The annual rainfall on one square yard of this region in a wet year may be enough to flush one standard toilet once. Considering that only a proportion of that rainfall is collectable, averaging 10 percent, consider then the square footage required to supply one toilet flushing once a day for a year. Just for that purpose and assuming there will be no water lost in storage it would require 29,486 square feet of land. Surely in a region of scarce water the notion of pumping algae from production lakes to ceramic food receptacles in individual dwellings is no less ridiculous than mixing one part excreta with one hundred parts precious, clean water to have it transported to energy intense treatment facilities which then unsuccessfully try to separate the two.

The supply to a settlement of 3 gallons of water per person each day, section 3.3, interrupts the water cycle by the human need to drink and clean with water. As an additional vehicle to transport excreta this minimum requirement of 3 gallons is more than tripled to 10 gallons of water per person each day.

The most viable alternative which duplicates the ultimately mandatory life cycles is the composting or humus toilet. A human produces about two and one-half pounds

of excreta per day, two pounds urine and $\frac{1}{2}$ pound feces. Water makes up 75 percent of the feces and 94 percent of the urine while total solids of about $\frac{1}{4}$ pound are contributed equally between feces and urine. In a composting toilet neither the aerobes which produce a low quantity

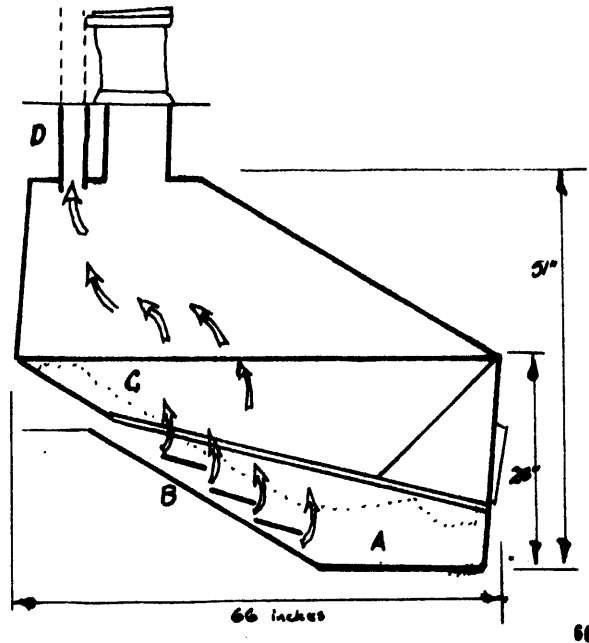

of methane or the pathogens can survive while better adapted bacteria expand to convert the excreta to a low grade fertilizer. As a fertilizer it has been shown to have a nitrogen-phosphorous-potassium ratio of 20-12-14. In contrast to the sudden shock of chemical fertilizer, the nutrients in the compost are primarily in the form of bacterial protoplasm, released slowly to plants as the bacteria breakdown. The illustrated aerobic toilet is designed by Enviroscope Inc. A is the waste deposit on the initial bed, 9 ft^3 peat, 3 ft^3 earth; partial removal required three or four times a year. B is the slope which prevents packing and ensures aeration. C is the air drawn through the base of the decay bed to increase decomposition of humus. D is an electric fan which draws evaporated liquid and gases out a vent.

Building Materials 3.10

The design of a building should always occur with a full understanding of the specifics of the actual land the building will be built upon. The actual loads of the building, the actual soil properties and the actual structural properties of the materials used should be concurrent with the design. It has been said that without water there is no need for soil mechanics. True as this is, problems of wind erosion, compaction difficulties and bearing capacities do occur and standards for this region such as the eighteen inch frost line and a low estimate of three thousand pounds per square foot soil bearing capacity will not be sufficient.

Further if a builder investigates the properties of the earth which he will build on he may be encouraged to get down into it more often. The most convenient and ecologically balanced building materials for a site of land in this region is the land of the site. The continuing cool temperatures of the earth, section 3.6, and the ability to use the earth in place as walls, roofs, and partitions in combination with injections of stabilizing material such as lime or cement only begins to examine its inherent qualities.

Earth has long been used as both the entire building, such as caves found or excavated and as a unit or continuous masonry material. Adobe the common term for building earth

was originally used in arid climates primarily because of the lack of rain and a predominance of sun made it very durable. Excavations at the site of smelters for King Solomon's mines in North Africa revealed the use of

adobe bricks in construction. The word adobe is Spanish and it comes from similar sounding words in Arabic meaning to smooth or mix. Some of the earliest dwellings in the southwest U.S. were pit houses which took

advantage of a natural depression in the earth, banked up excavated material and roofed over with brush and timber.

Wattle or jacal construction was the refinement of the pit house, posts and brush embedded into the ground woven with twig mesh and then plastered with earth. Rammed earth or pise' wall

construction uses a form in which to pack the mud.

Presently adobe is most commonly understood as a sun-dried or fire baked brick usually measuring 10"x4"x14" and weighing 35 to 40 pounds. Additives such as cement may increase strength to 100 to 150 pounds per square inch

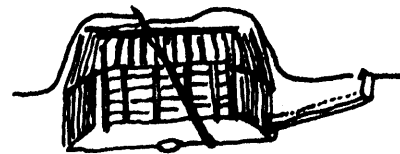
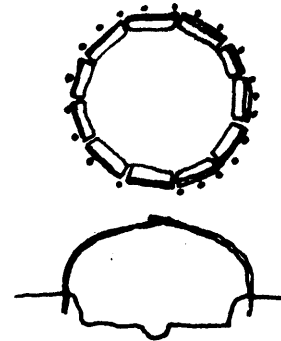
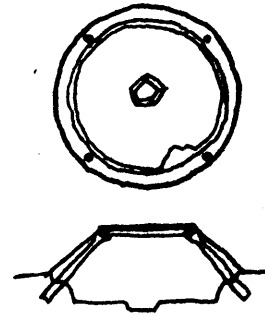

Pit Dwellings

while 5% to 15% asphalt to waterproof the adobe will weaken it slightly. Due to the high content of caliche, gravel and sand in this region locally manufactured concrete is also an option. Calcium carbonate, CaCO_3 makes up 79% of caliche while quartz, SiO_2 makes up the remaining composition. Naturally the most abundant and appropriate formwork for the concrete is the earth from which it is made. Paolo Soleri's workshop in Scottsdale, Arizona and a house in Flagstaff (figure 83), provide some excellent examples of the flexibility and continuity which earth forms provide concrete. By piling earth up as an accentuation or continuance of a strata formation or igneous intrusion the csts can become in both form and surface a continuation of this ground.

The relative stability of ground temperatures ten feet below the surface give strong indications of the effect which increasingly dense materials will have on the normal forty degree daily air temp. fluctuation for dwellings above grade. Inside and outside daily wall temperatures were

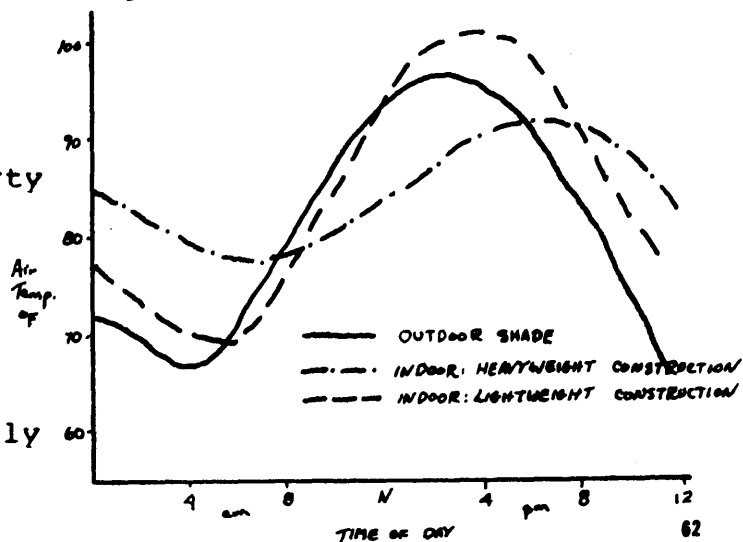

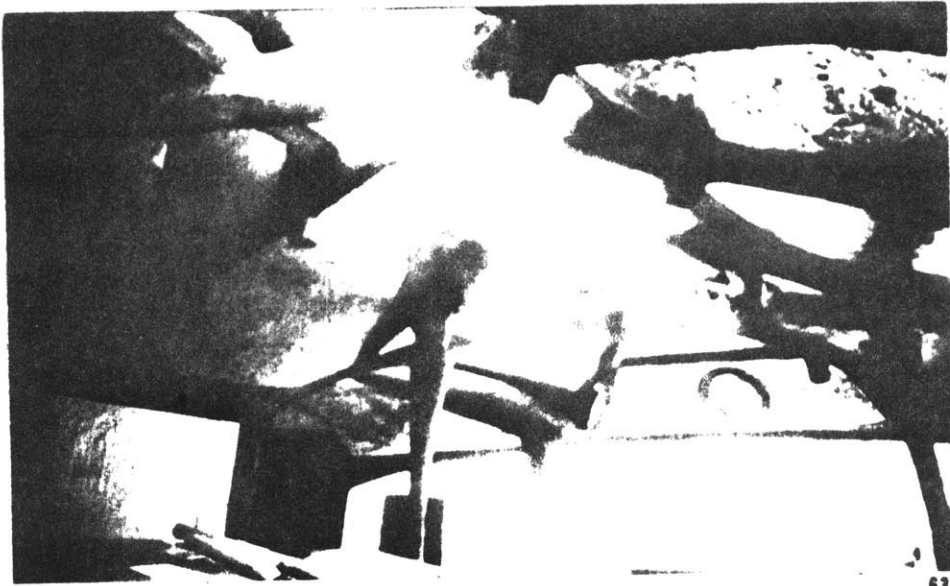

Earth formed concrete ribs; Dwelling in Flagstaff, Arizona

temperatures were recorded for solid concrete walls of .5, 1 and 2 feet in thickness. The graphs illustrate the expected response. A comparison of light weight construction with heavyweight masonry construction and outdoor shade illustrate that for the latter portion of the day an occupant of a light construction dwelling would be 5 degrees cooler outside in the shade than inside. The graph also shows that while a massive material stabilizes air temperature it also retains it suggesting a combination of dense

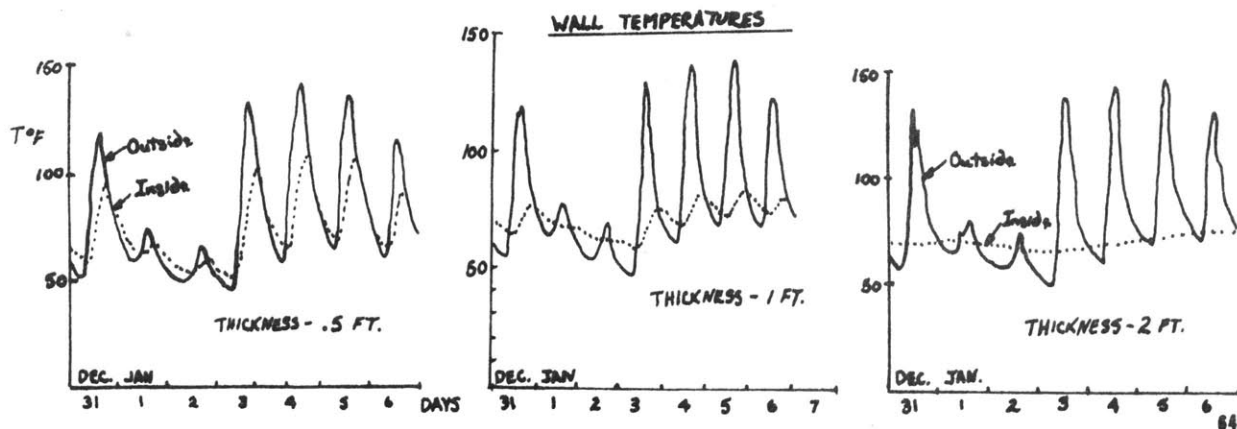

construction for day use and light construction for use between 8 p.m. and 8 a.m. Heavyweight construction not only consists of dense material such as earth, concrete and unit masonry but it also includes insulation which will be most effective in providing additional thermal damping if it is applied to the outside of a wall.

Translucent gypsum sheeting used at the Acoma pueblo (New Mexico, not distant from this site), for many centuries is probably one of the most stable glazing materials yet in its local absence, glass is the most appropriate. Certainly plastics, including paint are primarily not suitable as a building element in this region due to the relatively rapid photochemical decay which they will undergo in continued exposure to sunlight.

The ROOF 3.11

A flat roof is among the most stable roof structures for it provides the least outward thrust on a set of supports or walls. Pitched roofs shed frequent water and potentially heavy snow loads, neither condition occurring in this region. The flat roof also provides the advantage in that it can be used as a useful space. In being horizontal the roof is also the surface which in comparison with any vertical orientation receives the most solar radiation in the year and of primary concern, the maximum radiation levels in the hottest months of April through August. An exception for roof pitching would be in the desire to collect heat for hot water or gas absorption cooling; the optimum would equal the latitude for maximum gain in the summer.

To decrease the amount of solar radiation heating the air and the mass of a building, numerous roof configurations have been devised. The first, previously discussed, is an increased mass and insulation. A second means is to create a passage for air to flow either under the roof or between two separate roofs. This principle of roof cooling lies under the assumption that convection transfers heat to a space and therefore air movement under a heated surface should convect to it away. Designs such as 4 and 5 of figure 3.11, although convecting some additional heat away by an

air passage , the roof will primarily avoid heat gain by their thermal mass. The expense of providing an otherwise useless space between two separate roofs is therefore an unreasonable investment. Obviously a useable space with its own roof will shade a lower roof and provide less heat transfer to its space.

As suggested in the previous section this upper space might be constructed of lightweight material which while providing shade to the massive day space below would only be used at night when it would cool relatively

quickly. Still this does not solve the situation of an upper floor in a multistory construction or a single story where the space adjacent to the roof is used in the day. In this condition high ceilings and upper clerestory windows or upper wall ventilation will often provide the necessary comfort at use level.

Due to the heat storage capacity of water another means of creating thermal mass in a roof is to install ponds or bags of water continuously across the roof's surface. The sections (figure 66) are of a house built and tested first in Phoenix and then built in Atascadero, CA., which has a

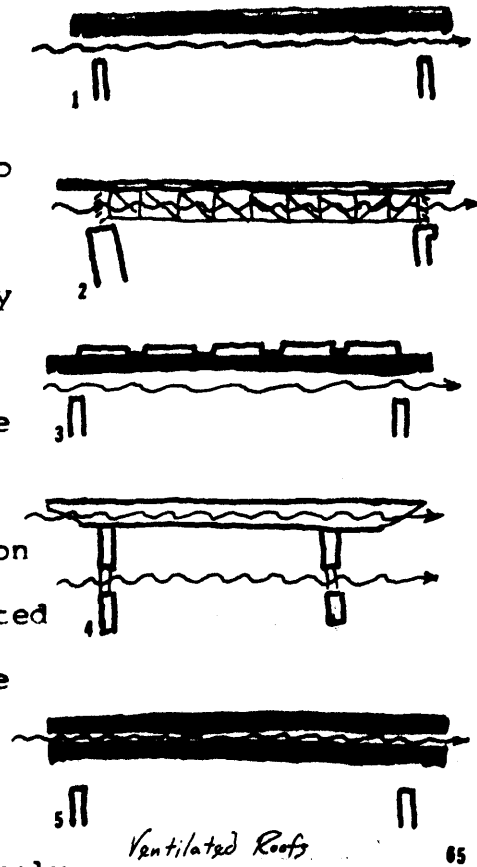

climate similar to this region. The roof provides a year-round balanced temperature between 66°F and 74°F with no supplementary heating or cooling with outside temperatures ranging from 100°F to 26°F . The indoor temperature at the 5 foot level indoors cycles less than 4°F with a daily outdoor range of 32°F .

Three feet of earth would be required to equal the thermal mass of the 8.5 inch water pond. The advantage of this roof over the three foot earth cover lie in the relative ease

with which the ponds can be covered with a 8'x12' moveable insulation panels for summer daytime protection (or winter night storage) and then mechanically slid bak for summer night radiation cooling (or winter day radiation collection).

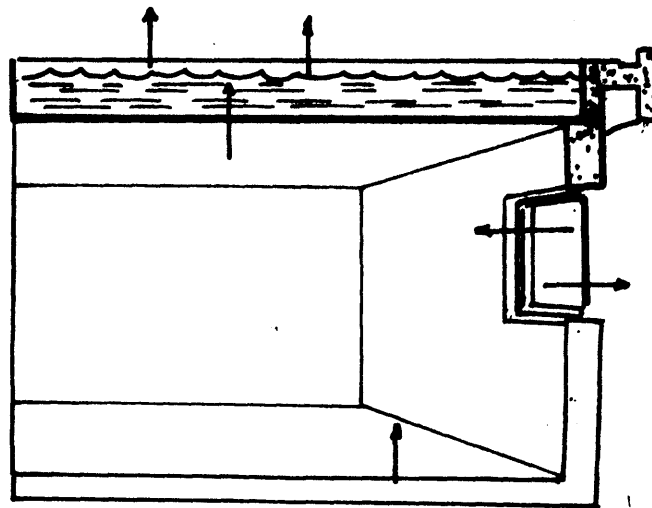
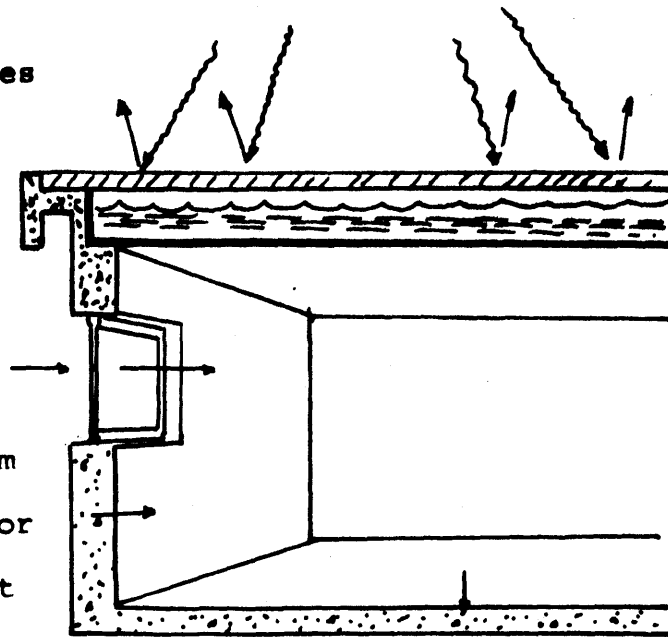

Sections of Atascadero dwelling

A tensile element such as wood or steel is required to build a flat roof. Since these tensile materials are less prevalent on the site than the materials which act in compression, roofs of these materials should be given priority. In order to

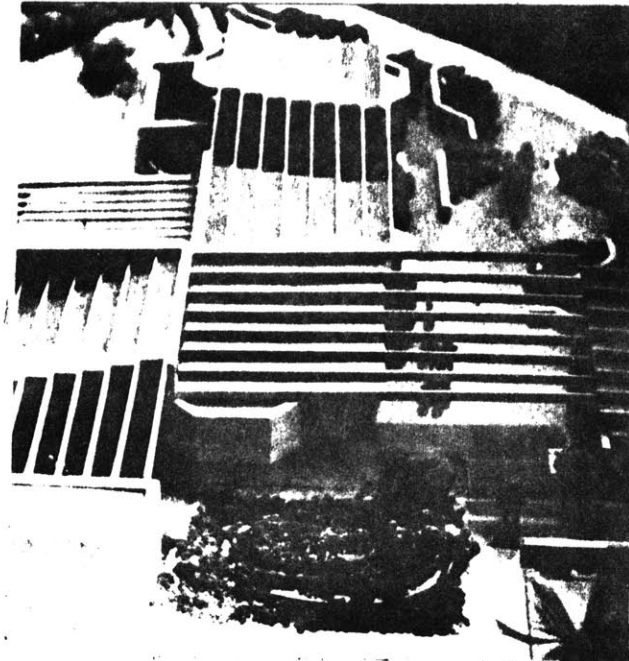

Model illustrating moveable insulating roof panels

67.

attain comparative strength, compressive materials need to take advantage of curves which offer this continuous strength. The barrel vault, ribbed vault, dome, groined vault and corbeled roof with their endless variations all work under compression.

In underground excavation it makes considerable amount of sense to build in curves. There is a simple relation between the curvature of a shell, the stress acting in a shell and the pressure that is acting on the shell from the outside. The form of the relationship is expressed in figure 8. From this relationship one can see that a soil cement, consisting of lime injected into a soil with adequate clay content will make a very acceptable shell, spanning at least twenty feet. If the excavation is deep enough the soils will arch by themselves.

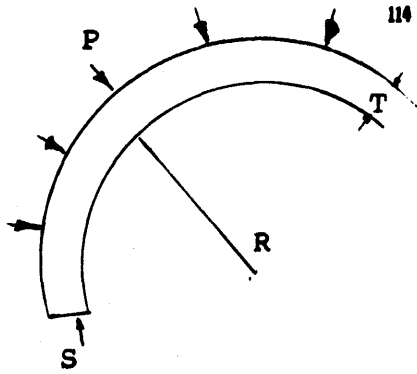

R= radius of curvature
 S= shell stress
 T= shell thickness
 P= pressure

$$1/R = P/ST$$

11

Even though a curved roof will receive the same aperture of solar radiation as a flat roof, the radiation will be distributed over the larger curved surface area, sustaining a lower roof surface temperature.

Just as air flow over a wing creates less pressure on the upper surface and therefore lift, a curved roof will create more suction/uplift pressure and a greater wind speed than a flat roof. The greater uplift pressure is usually adequately compensated for by the normally heavy masonry used in its construction. The greater wind speed over a curved roof than over a flat roof determines a decrease in surface temperature of the curved roof due to an increase in air convection of heat.

CLOSURE 3.12

A primary objective of closure in this region is to prevent direct sunshine from coming in contact with the interior for two-thirds of the year. This can be provided by shading the walls, openings and roof surface. This does not mean that the framing materials of wood and steel can compensate for the thermal mass required to stabilize temperature. However these relatively slender materials can be most effectively used on the exterior of a building to intercept the first rays of the sun while not storing the radiation for extended periods. Frequently when the shading devices are constructed out of dense material, cool night air becomes unfortunately heated by the shading devices before entering the structure.

Different types of glazing for an opening can vary the amount of solar heat transfer. If regular

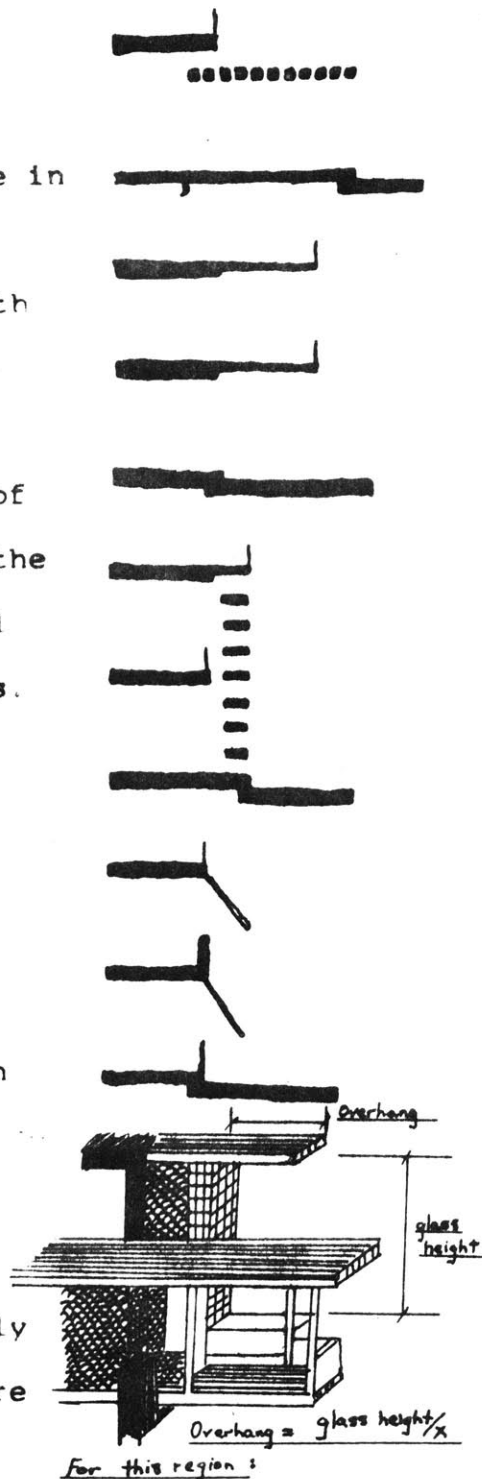

single pane glass is 100 percent transmission, double glazing is 73 percent, heat absorbing is 68 percent, double heat absorbing is 51 percent and glass block is 50 percent.

Every opening in a structure decreases its thermal mass which stabilizes interior temperature. It is appropriate therefore to have as few openings as possible and only in the directions allowing increased comfort to the interior. The one-third of the year requiring heat dictates an uninterrupted path of radiation from zero to thirty degrees altitude towards the optimum orientation, southeast. Allowing this radiation to strike on a masonry surface provides an extended period for use of this heat.

The second primary location for opening is within the interior of a building. A common court approach allows increased interior exposure to an enclosed outdoor space.

This allows heat to be absorbed by a body of water or vegetation within the court, lowering by increased humidity the dry bulb temperature of the air. The higher stored heat of the water body then

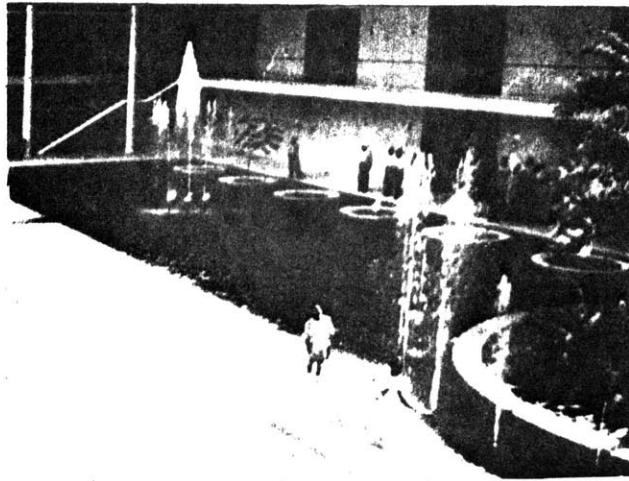

Interior Court Fountains
U.S. Embassy Delhi, India

aids in convection of hot air from the inside out through the court opening. The drawback to this approach is that the internal court allows a much greater radiation gain than would occur with a continuous

roof. In addition the water used to store heat and encourage convection will be rapidly evaporated to the dry air. The internal court approach offers a dramatic enclosed space with operable windows or ventilation

paths provides decreased internal heat gain and a decreased loss of humidity from a court pool or a fountain which decreases the interior dry bulb temperature.

In the months of May through October air movement in the interior of a dwelling increases comfort. In Egypt, North Africa, Pakistan and Arabia the principle of drawing a prevailing breeze from a large shaft, wind tower or wind wall has been long known as a basic ventilation method for this climate. It was known to the ancient Egyptians as found in the houses of Tell el-Amarna and as represented in the wall paintings of the tombs of Thebes.

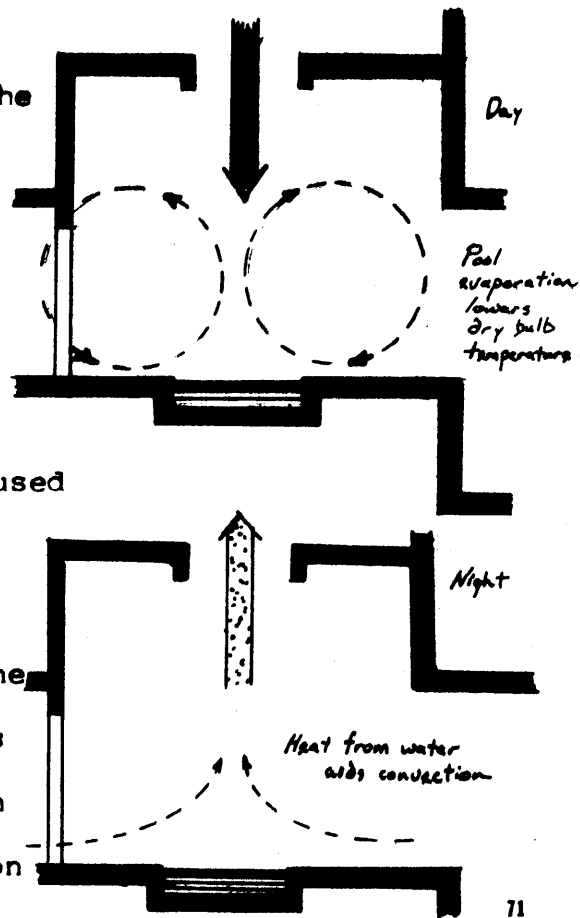

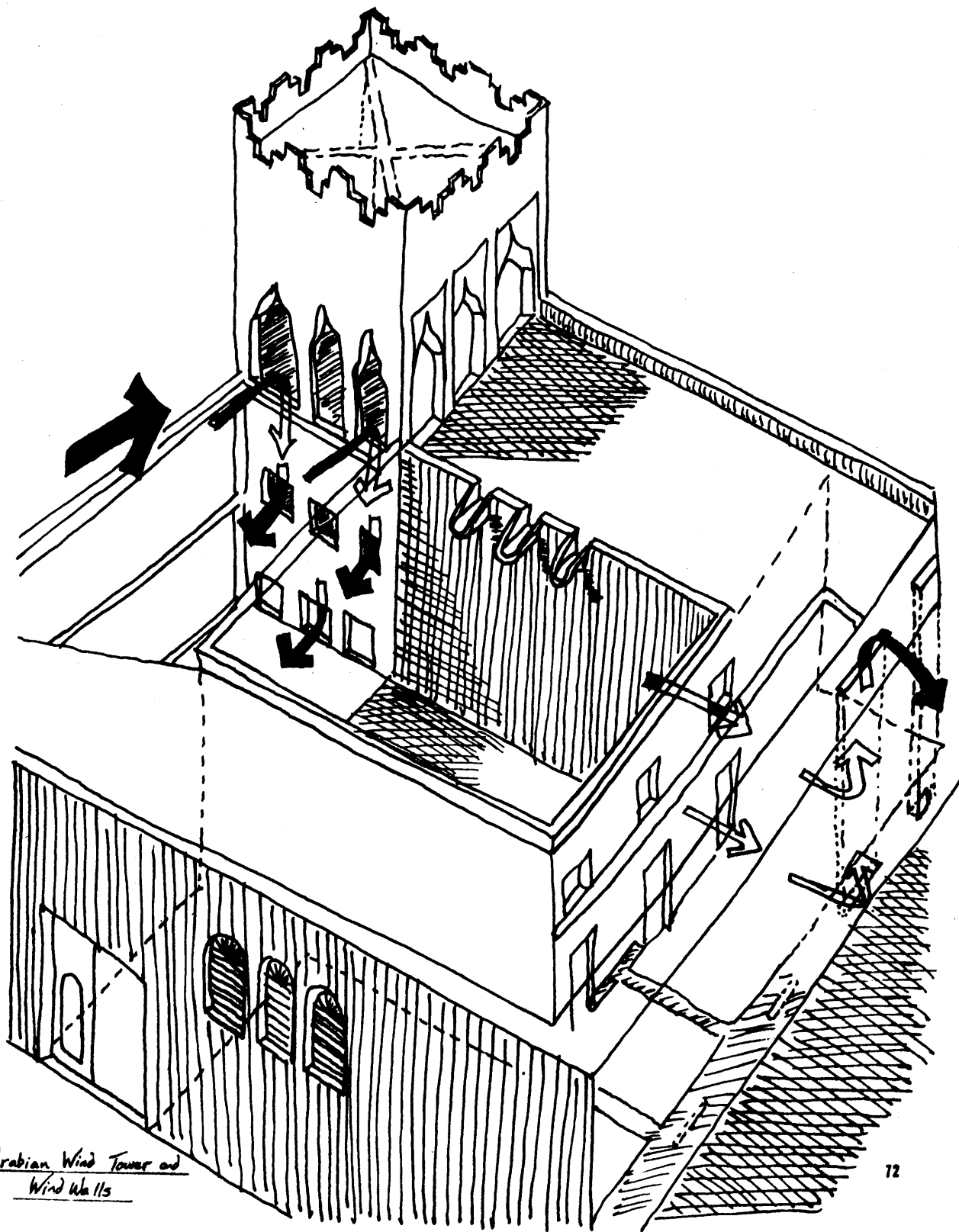

Arabian Wind Tower and
Wind Walls

The house of Neb-Amun 1340 BC places a hall in the middle of the house with two vents, one to windward and the other to leeward to balance the flow. An improvement over this design exists in the Qa'a of Muhibb al-Din 1350 AD where a shaft to



House of Neb-Amun

windward is balanced by high windows in an elevated space in the center of the building. ⁷³

To design such natural ventilation systems requires knowledge of the prevailing winds in the months ventilation is needed the most. This would be east for the south lowlands of this region and southwest for the mesas and the mountains. The area of exit ventilation should be greater than the inlet shaft area to allow a slightly negative pressure to exist within the house increasing air movement even with no wind. Due to the high quantity of dust in the air a replaceable low density filter should be included in the air inlet. Further just as the night air will heat up, passing across dense louvres or a shading device, air passing over a hot roof or down a hot shaft will provide hotter slower moving air than the wind.

Closure is also essential in providing protection from the wind especially in regard to the inevitable raging dust and sand storms. A few governing parameters

for dimensions of enclosed space is in order. Even though the larger particles which are the most abrasive will increase in density near ground level, the dust will penetrate everywhere, and it is best to estimate the relative protection offered by eddies from the main flow. Any enclosed space is best oriented with its short dimension perpendicular to the storm winds. The maximum length of this space should not exceed three times this short dimension. Retractable sun shades and sliding panels can provide increased protection to glazing, court or enclosed space. A space potentially facing the prevailing direction adjacent to a single story dwelling can be protected by a barrier the size of this dwelling up to twenty

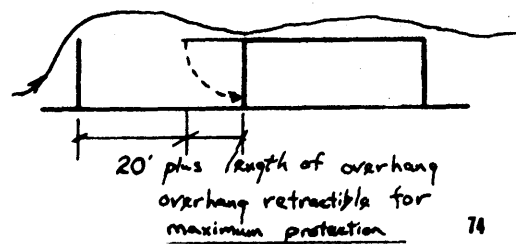
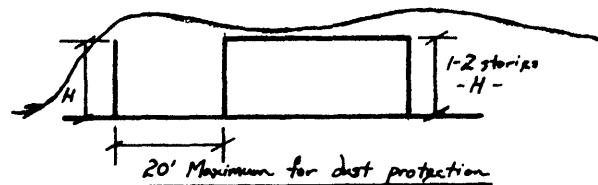
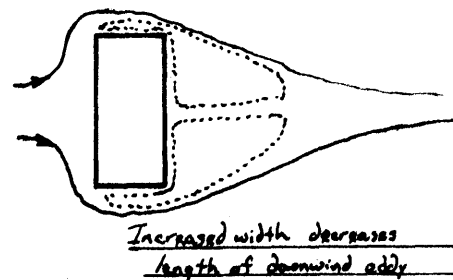
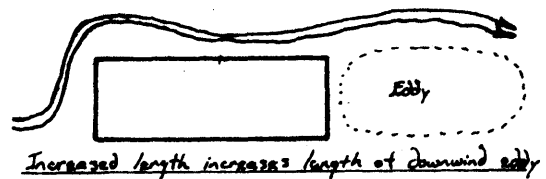
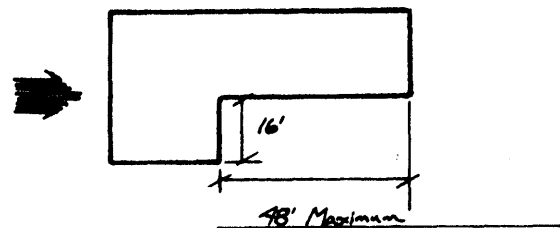
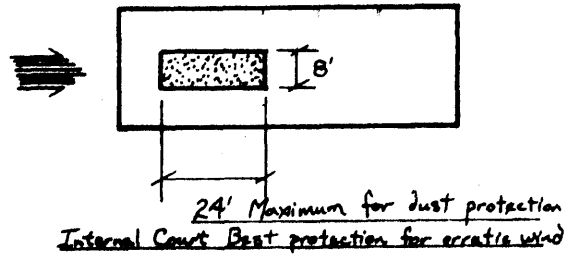

feet away. Overhangs will extend this range.

Closure provides the major third purpose of letting in light to see and seeing out. Light from above is usually the most flexible and can be conveniently provided by the need for clerestory ventilation. For openings at eye level, screens provide a subdued contrast between the darkness of the interior and the bright light. The glare is increased at ground

level by the light reflecting off a typically light colored surface, indicating that the screen should be a finer mesh near the ground. The actual shape of the bars of the screen will also affect the

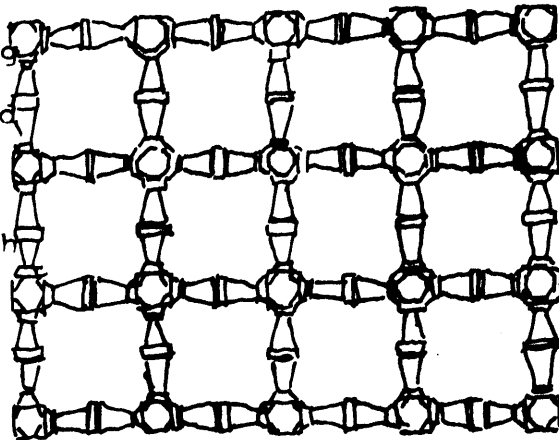

light quality. A square or object with flat sides will reflect a large band of light in comparison to a round object. Therefore it is not surprising to find that many Arab screens are of turned wood with a large mesh in the upper part and a close mesh at the bottom.

Typical Arab Screens

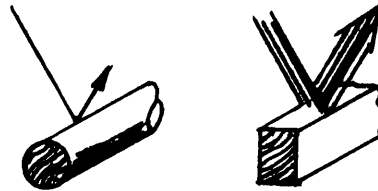
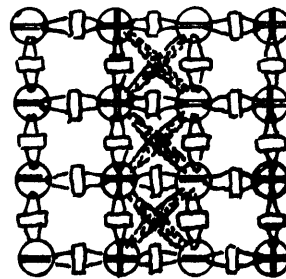

Light Reflectance

With a partial understanding of this land and its climate and methods with which we can build with this understanding it is inexcusable to overlook the precedents of builders who have lived in climates and lands quite similar to this region for thousands of years.

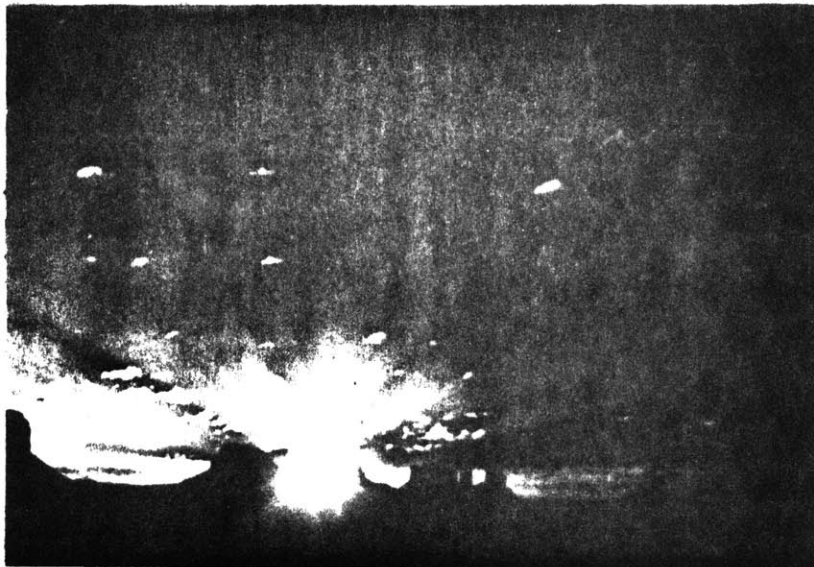

BUILT PRECEDENT 4.1

Fifty kilometers southwest of the Gabes oasis in southern Tunisia over two thousand dwell in an intricate network of tunnels and caves of carved sandstone known collectively as Matmata. A narrow passage of three to six feet in width angles down twenty to thirty feet past grain and animal chambers to a central court open to the sky of forty to two hundred feet across. The crater equivalent to a street is the collective space of up to 100 dwellings which are entered along its perimeter. Being totally of the earth the village at a distance becomes



11

almost invisible, a continuous camouflage among the curves of the landscape.

SIZE: 2,000 residents

COLLECTIVE SPACE: 20' deep, 40' across to 30' deep, 200' across

BUILDING HEIGHT: 20'

BUILDING MATERIAL: Sandstone

ROOF FORM: Dome

In a limestone cliff near Camp Verde in northern Arizona a five-story, twenty room apartment has been continuously among the most comfortable and prestigious dwellings in the southwest. Located eighty to one hundred and thirty feet above the dry river bed below, the dwellings, known as Montezuma's Castle, are thoroughly shaded by a forty foot overhang and alternatively receive winter sunshine uninterrupted in the months when it is needed the most. Straight roof beams support evenly sized branches which when covered with mud plaster become monolithic with the mud covered limestone walls. Potable water is supplied from a sink hole in the limestone strata which supplemented the floodplain fields along the arroyo below.

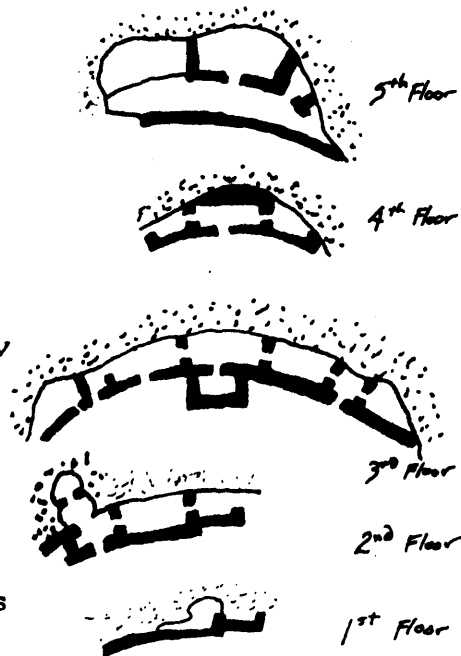
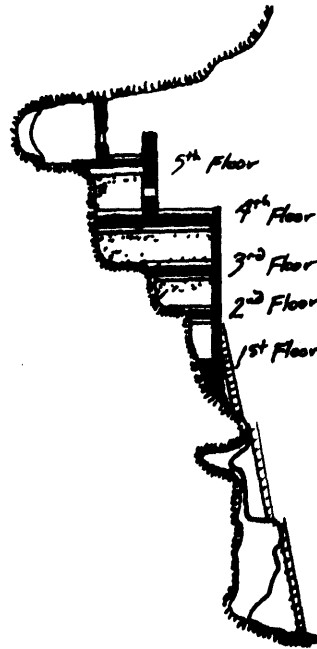

MONTUZUMA'S CASTLE

SIZE: 20 rooms/ 60 residents
FORM: Curves of cave
WATER SUPPLY: Spring, arroyo
ARABLE LAND: Floodplain of arroyo
ORIENTATION: South
BUILDING HEIGHT: 50'
BUILDING MATERIAL: Sandstone, mud, wood
ROOF FORM: Flat; Cliff overhang
SHADING: Cliff overhang

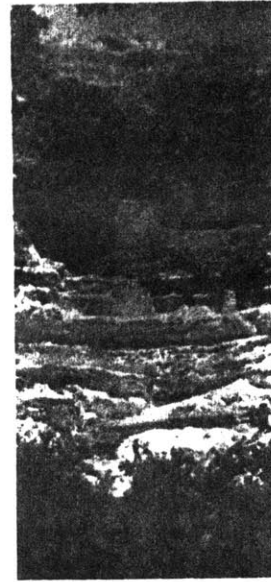

79

Mountain 4.2

The mountain villages of the arid land of Morocco are built primarily of stone. There are no ceremonial gates or walls surrounding the villages for their strategic location is a formidable defense in itself. The one to three story dwellings are built directly from the material of the slopes, often becoming a continuous succession of terraces which are barely separated by narrow largely covered alleyways. The long axis of a building is commonly along the contours of a slope with variations in the terrain guiding the particular placements and interconnections of alleys within the village. The stone for walls is laid up with a mortar of clay or lime and earth tapering to a minimum dimension of 50 centimeters. These walls bear pounded earth floors over wood beams or entirely wooden floors. Wall openings are rare and of small dimension which are usually closeable by wooden shutters rotating in wooden frames or more recently by forged iron trellis work. The wall is then

finished by a protective overhanging layer of palm branches held in place by stone.

AIN LEON

LOCATION: Middle Atlas mountains of Morocco, 20 km. SW of Azrou in the region of Ait-Mouli

FORM: Both slopes of a winding river valley

WATER SUPPLY: Mountain brook

ARABLE LAND: Lower end of valley along river

COLLECTIVE SPACE: Courtyards off alleys - 9.3 m^2 , market square

DISTANCE BETWEEN BUILDINGS: alleys - 3-4 meters

BUILDING HEIGHT: 2 story - 6.4 meters

BUILDING MATERIAL: Stone, clay plaster, loam, wood, slate.

ROOF FORM: Flat

WINDOW:WALL RATIO: 1:14

SHADING: Overhangs, screens

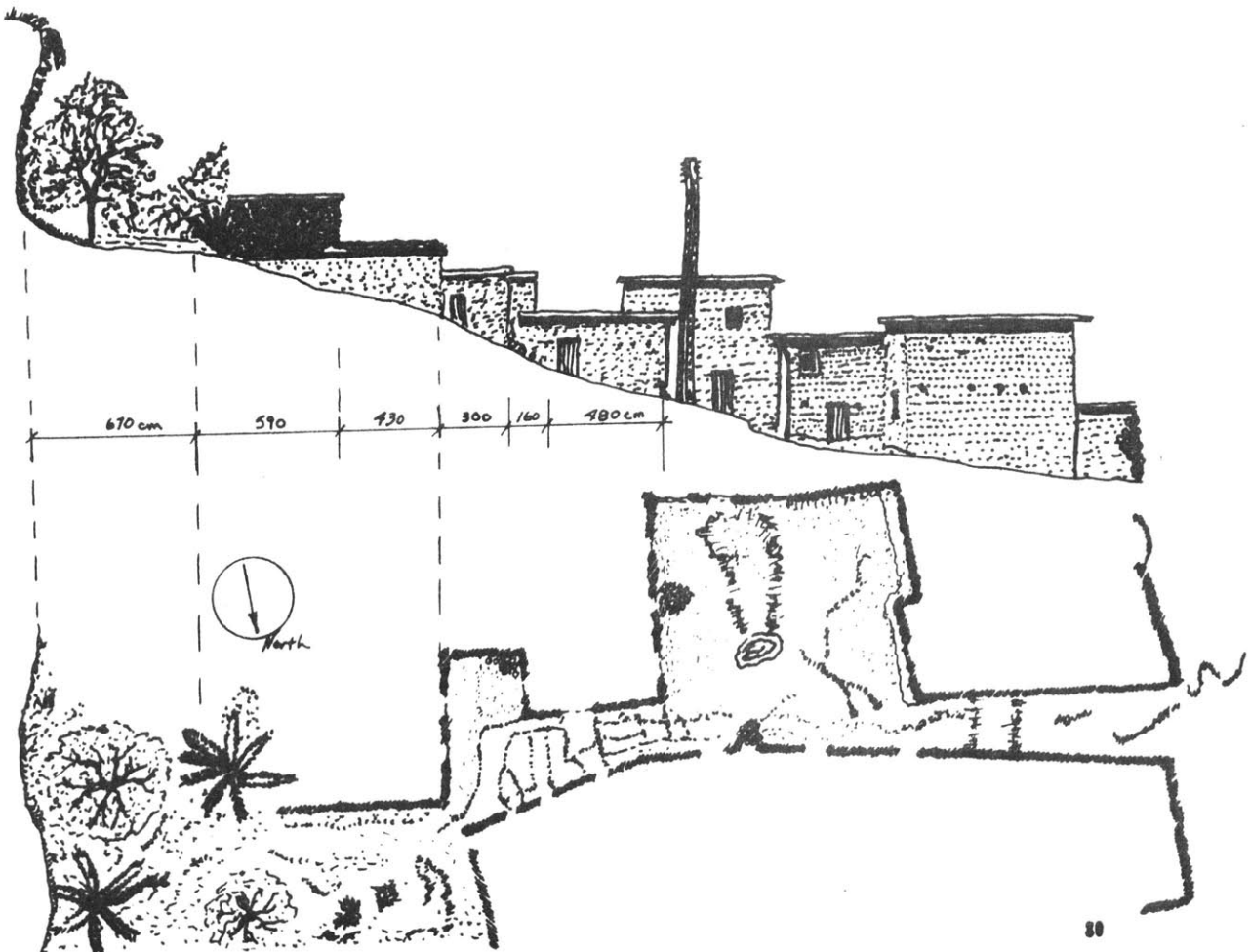

OUBIHA VALLEY

LOCATION: Southern Morocco near Marrakech

SIZE: 50 dwellings

FORM: Horizontal layers of rectangular dwellings parallel to the slope contours

ORIENTATION: Long axis parallel to slope

COLLECTIVE SPACE: Interior courts 10'x30'

DISTANCE BETWEEN BUILDINGS: 6'

BUILDING HEIGHT: 2 story

BUILDING MATERIALS: walls rubble and earth, roof mud and thatch

ROOF FORM: Flat

WINDOW:WALL RATIO: 1:8

SHADING: Thatch roof overhang



TIZI-N-TICHKA PASS

LOCATION: High Atlas mountains Morocco; pass links stone desert to Marrakech

SIZE: 100 dwellings

FORM: Linear, horizontal follows contours

ARABLE LAND: Terraces below village, South

ORIENTATIONS: South, long axis of settlement E-W

COLLECTIVE SPACE: front yard to uphill edge of each dwelling

DISTANCE BETWEEN BUILDINGS: 0 - 20'

BUILDING HEIGHT: 2 story

BUILDING MATERIALS: Stone, clay plaster, wood, mud, thatch

ROOF FORM: Flat

WINDOW:WALL RATIO: 1:8

SHADING: 2-3' thatch overhang



LOCATION: High Anti-Atlas Morocco
SIZE: 50 dwellings
FORM: Horizontal layers decrease up slope
WATER SUPPLY: River at base of slope
ARABLE LAND: Grains grown on both banks of river
ORIENTATION: South
BUILDING HEIGHT: 1 - 3 story
BUILDING MATERIAL: Stone, clay, mud, wood
ROOF FORM: Flat with parapets
WINDOW:WALL RATIO: 1:40



AIT. ABDARAHIM

LOCATION: Valley of Dades, NE of Boumalne, morocco

SIZE: 100 inhabitants

FORM: Irregular collection of structures, high N edge

WATER SUPPLY: Well

ARABLE LAND: S of settlement

ORIENTATION: Long axis E-W

COLLECTIVE SPACE: Courts, threshing floors to S

DISTANCE BETWEEN BLDs.: Alley 5'

BUILDING HEIGHT: 3 floors av.

BUILDING MATERIAL: Loam, wood

ROOF FORM: Flat terrace

WINDOW: WALL RATIO: 1:15, S wall

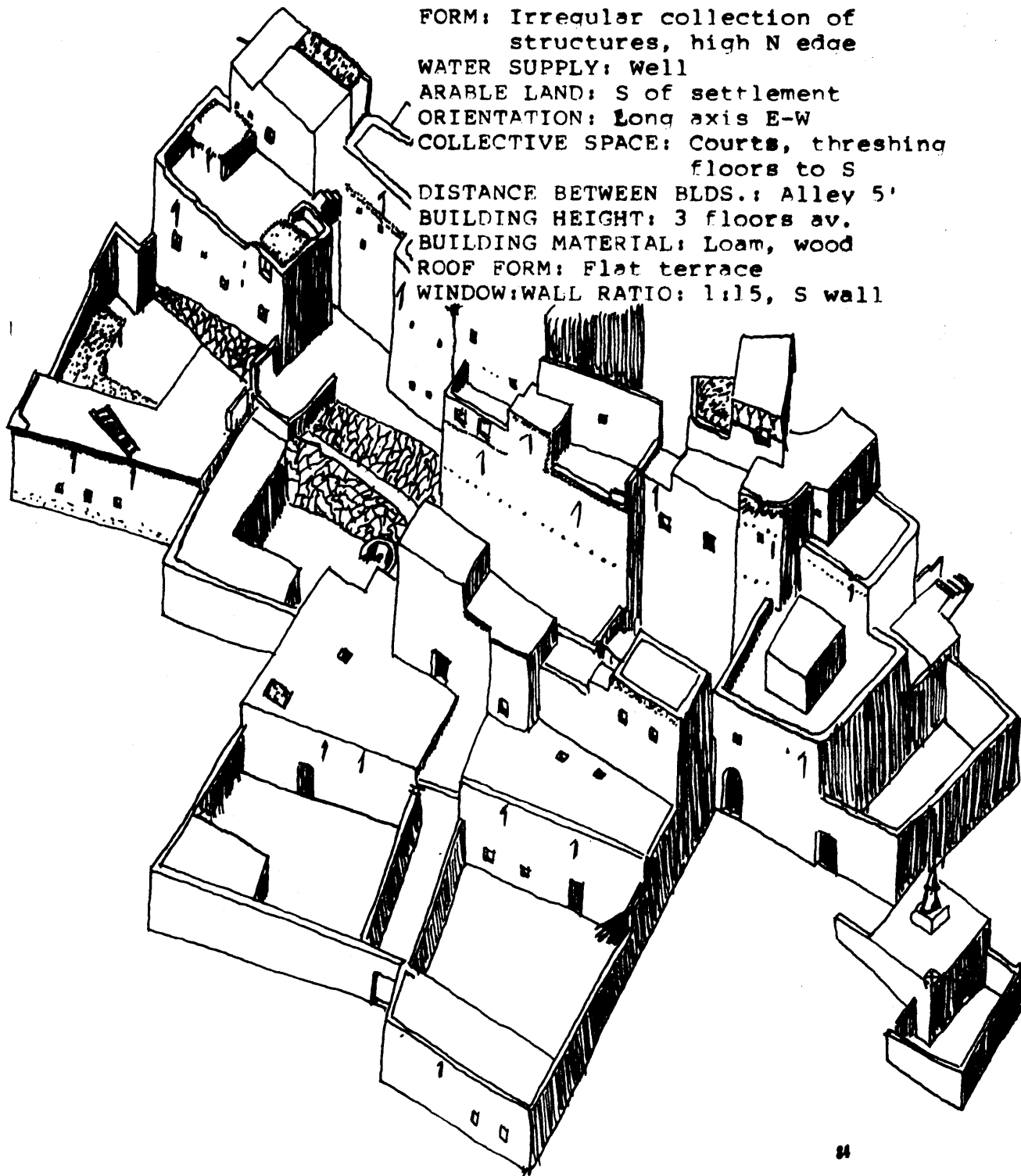

Hill 4.3

Around a hill in a valley of southern Tunisia, tribes of mountain cave dwellers sought to rebuild their caves of stone. The resulting barrel vaulted stone structures known as ghorfas were built in horizontal and vertical rows, defining a large oval courtyard to their center. The vaults rose to seven stories with an average of three; straiways provided by stones projecting from the front walls. One rectangular opening is provided per bay with storage spaces always at the lower level. A perimeter wall surrounding the structures provided a second edge allowing expansion to occur within the central plaza.



COLLECTIVE SPACE: Central court, 150 ft.²
 DISTANCE BETWEEN BUILDINGS: 15'
 BUILDING HEIGHT: 3 story av.
 BUILDING MATERIALS: stone, clay plaster, wood lintels
 ROOF FORM: Barrel vault

Between the high Atlas and Anti-Atlas mountains of southern Morocco, Ait Benhaddou surrounds the southern edge of a hill. The lower wall of the city protects the more than fifty kasbahs and ksars from the occasional torrential floods. Between the river bed of the Asif Mellah and the lower wall are rock grids of farming plots irrigated by runoff from the usually dry river bed. Within the city are endless mazes of dark, mysterious streets varying in width from five to fifteen feet, often becoming completely enclosed tunnels interdispersed with light wells.

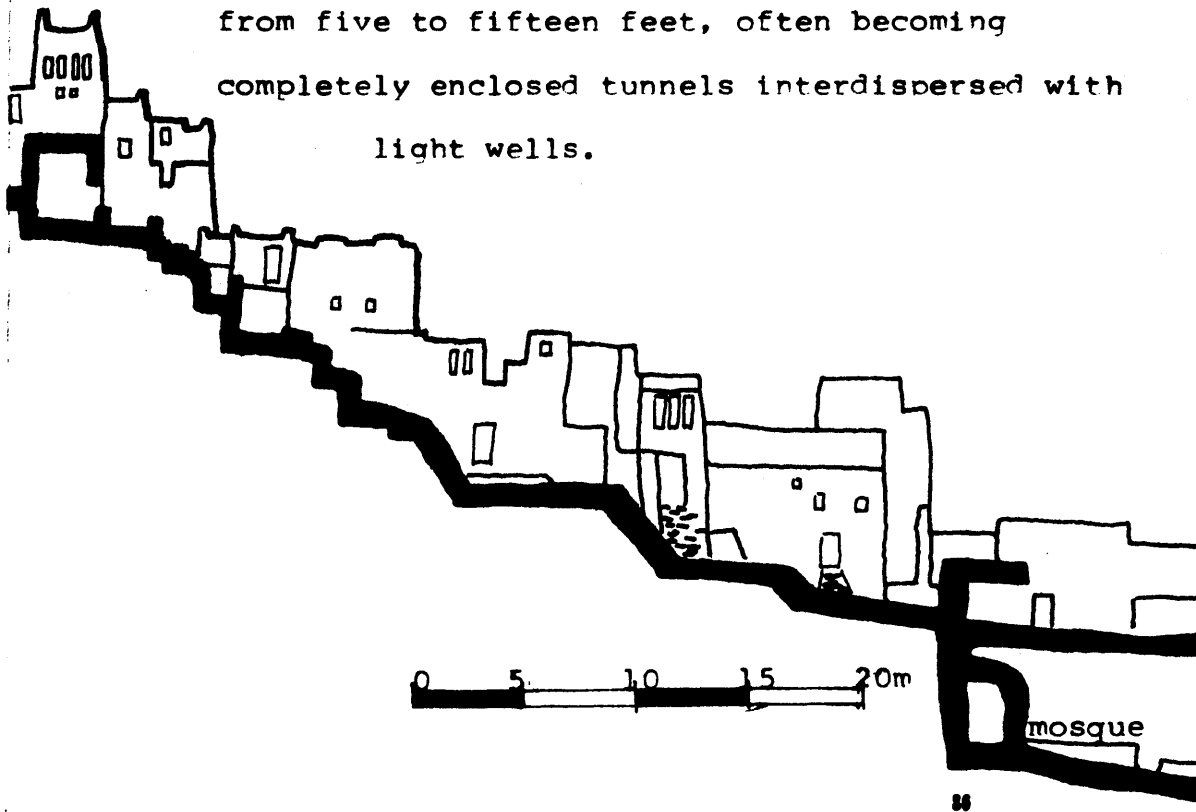

AIT BENMADDOU

LOCATION: Near oasis of Quarzaate, east end of valley
SIZE: 50 buildings
FORM: Series of kasbahs interconnected by ksars follow slope
WATER SUPPLY: Wells, runoff
ARABLE LAND: Gridded plots S of wall to river bed
ORIENTATIONS: Parallel to river bank; SW,S,SE
COLLECTIVE SPACE: Alley intersections
DISTANCE BETWEEN BUILDINGS: 10' av.
BUILDING HEIGHT: 40'
BUILDING MATERIALS: Red mud bricks, palm trunks
ROOF FORM: Crenellated towers, flat terraced roofs
WINDOW:WALL RATIO: 1:20 exterior walls

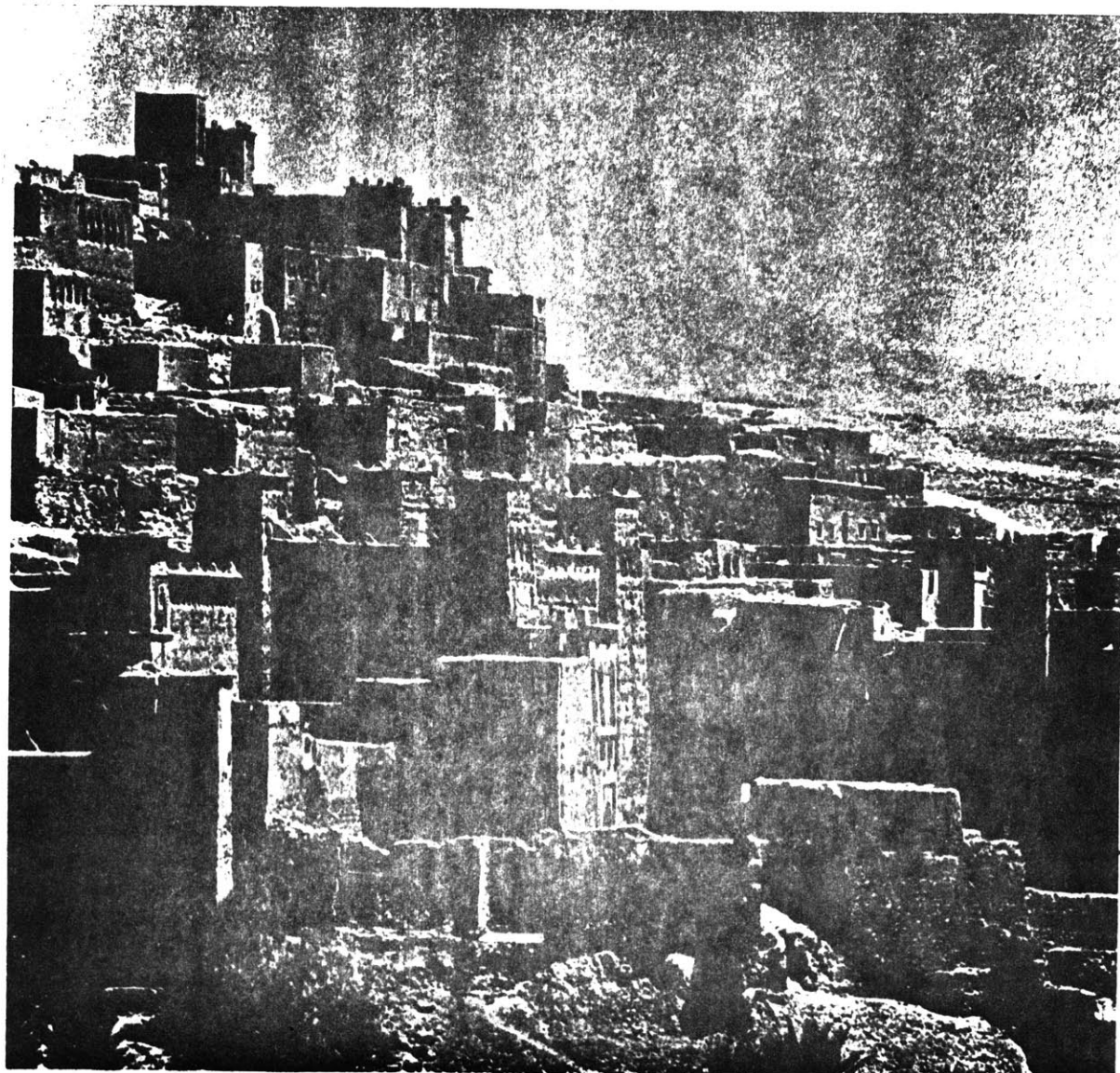

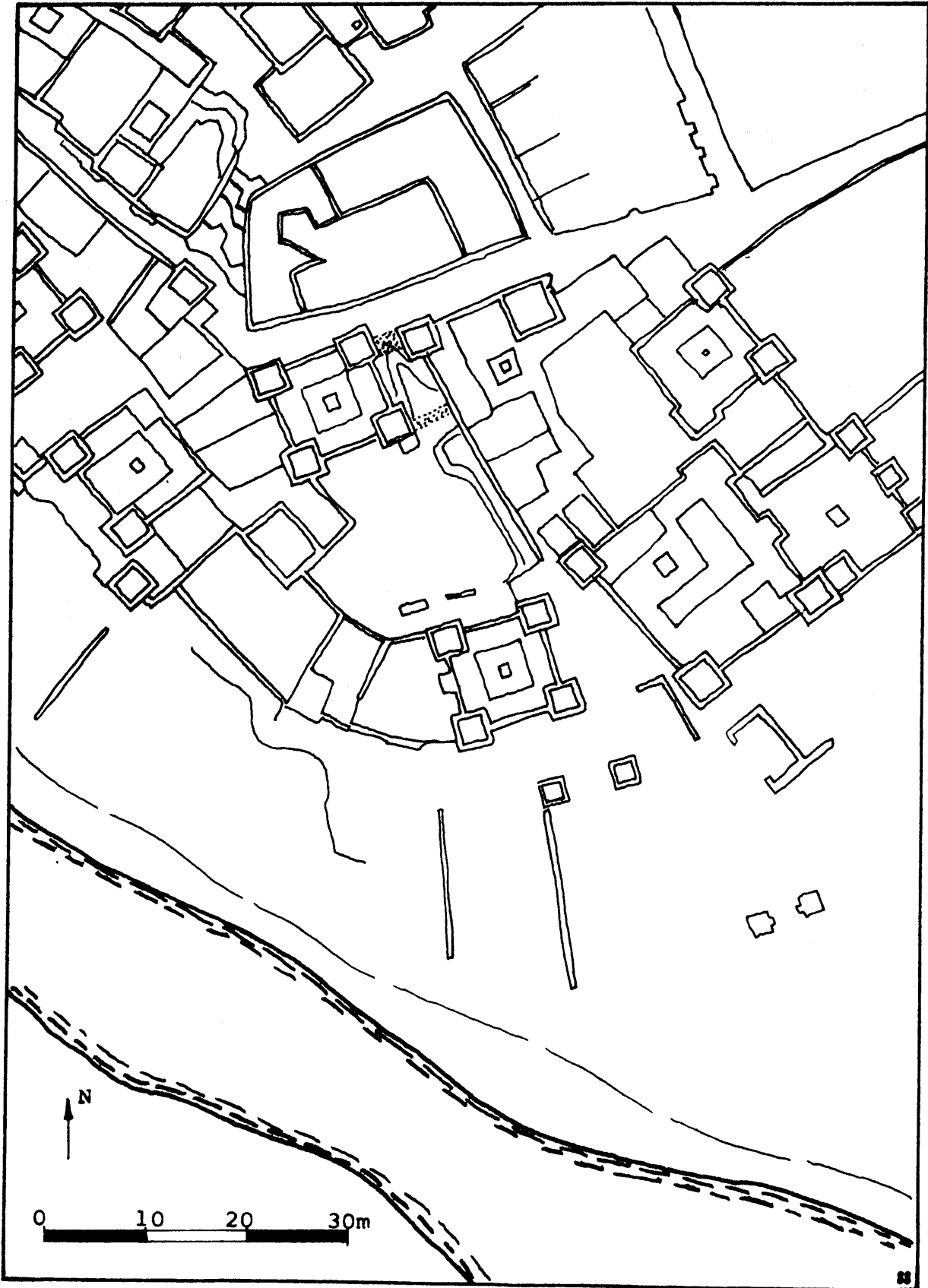

In the western part of the Thar desert in Rajasthan, Jaisalmer stands alone built entirely out of sandstone on a hill. Built originally as a fort to protect the Royal Palace and its prosperity as a trading center at the crossroads of caravan routes, the city now surrounds the triangular, higher and older city. The compact housing surrounding the fort is inside an irregular polygonal wall built primarily on the northeast of the hill to receive the least gain from the sun

while still receiving the morning sun. Arable land is located to the southeast of the hill along Garisar lake which supplies

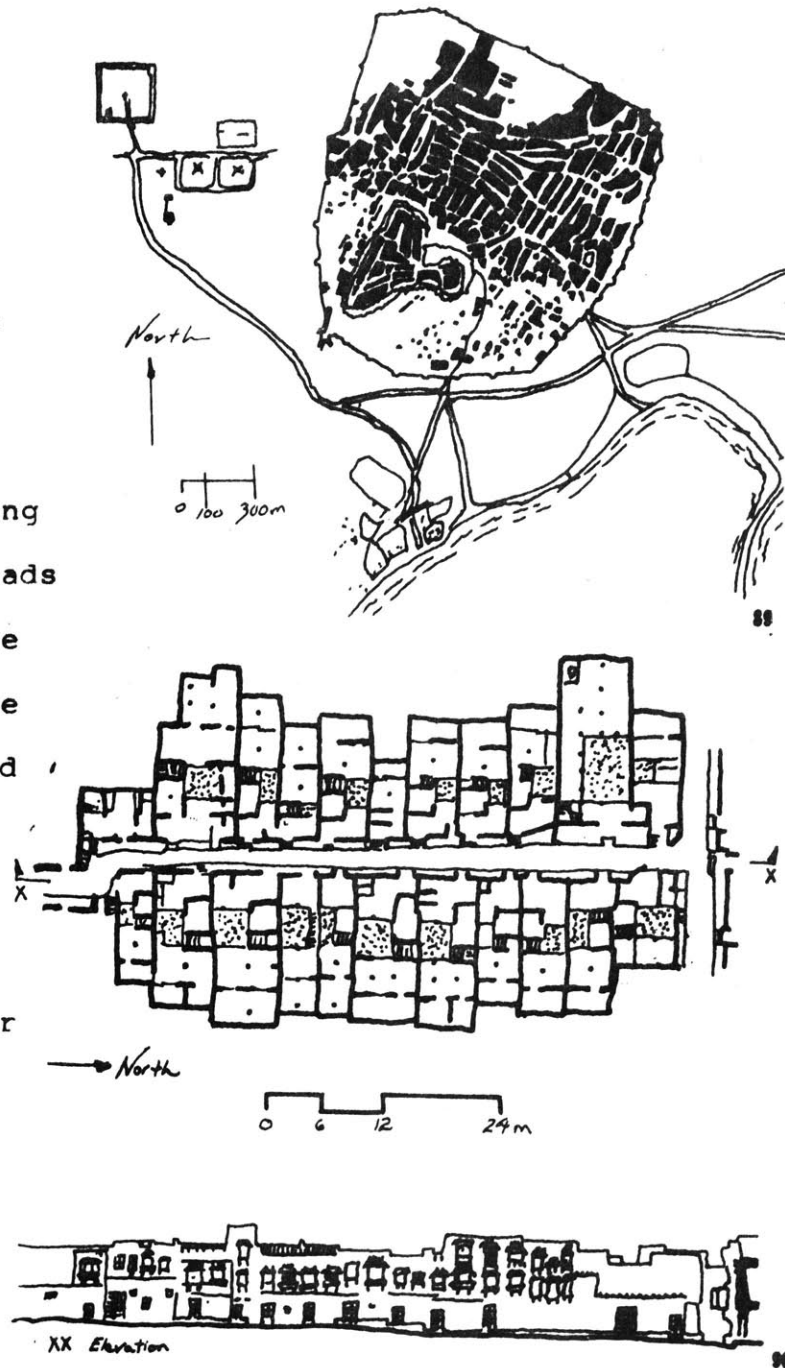

potable water. Compactly built of mass-carved columns, brackets, balconies, screens and three dimensional windows, the housing which reaches up to seven stories creates a cool order and harmony within a varying grid of narrow (2-4 m) streets.

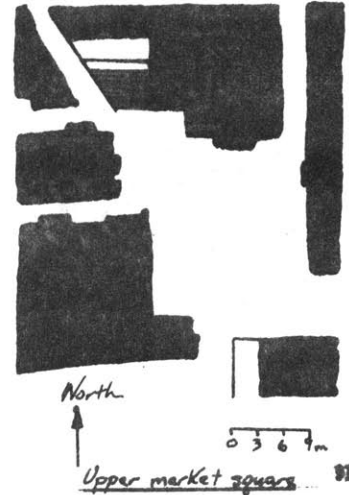

Jaisalmer

LOCATION: India, Rajasthan, 26°N

SIZE: 1,812,500 m²

FORM: Compact clustering inside irregular polygon

WATER SUPPLY: Garisar lake, groundwater salty

ARABLE LAND: Near lake

ORIENTATION: NW-SE, NE-SW streets

COLLECTIVE SPACE: 2 market squares, upper 20m²

DISTANCE BETWEEN BUILDINGS: 2-3 meters

BUILDING HEIGHT: 3 stories av.

BUILDING MATERIALS: Yellow sandstone, clay plater

ROOF FORM: Flat terrace

WINDOW:WALL RATIO: 1:16 exterior city wall

SHADING: Panel overhangs, screens

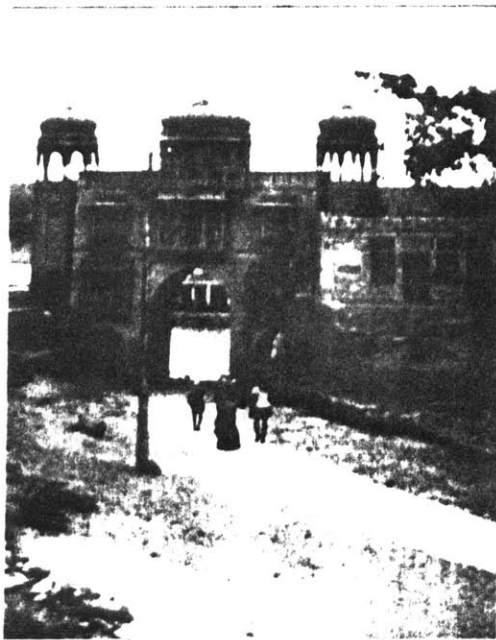

Main Entrance

92

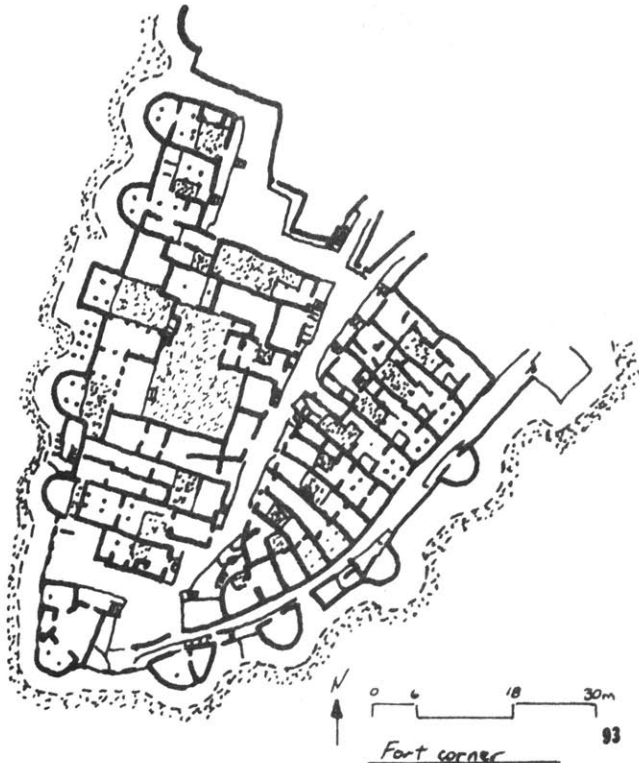

Fort corner

93

Mesa

137

Overlooking the plains of Tunisia fifty miles south of Tunis a series of plateaus jut out into the landscape. On the plateaus a range of rectangular and barrel vaulted stone structures were built on their heights. The generally single level structures built entirely out of stone enclosed interior courts averaging forty feet square and are interconnected by winding narrow passages. The flat roofs, barrel and groin vaults are usually accessible for food and fabric drying. The groin vaults indicate an entry within a block.

TAKROUNA

SIZE: 100 dwellings
ARABLE LAND: Orchards
and fields below
COLLECTIVE SPACE: 40 ft²
DISTANCE BETWEEN BLDs: 10'
BUILDING HEIGHT: 1 story
MATERIALS: Stone
ROOF FORM: Flat, barrel
and groin vaults
WINDOW: WALL: 1:20 exterior
1:10 interior





The oldest continuously inhabited settlements in the U.S. are located on the edge of mesas. The first is Acoma located fifty miles west of Albuquerque. The settlement is basically three parallel rows of terracing rectangular bays extending 1,000 feet in an east-west direction. The lower bays used for storage are inaccessible from the ground and can be entered from the second level. The levels progressively become smaller in length and height in the second and third stories, the wall facing north becoming verticle.

Adobe covered rubble comprises the first floor supporting adobe covered brick walls of the second and third levels with the floor layers of spanning timbers, branches and adobe.

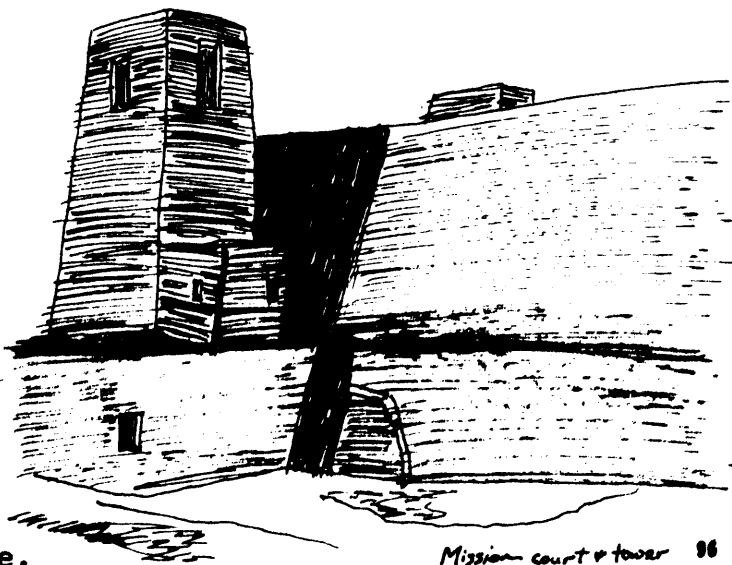

Mission court & tower 96

Verticle walls separating the structures often extend above the roofline two or four feet defining an open terrace on the upper levels. The more recent addition of the mission extends the limits of the rubble stone and wood beams to a sixty foot height and forty foot span while its orientation and material becomes a continuous extension of the mesa edge.

ACOMA

LOCATION: 50 miles W of Alburquerque, 35°N Lat., 7000' ele.
 SIZE: 200 dwellings, 1,000' E-W
 FORM: 3 parallel rows, groups within rows, modular tiers
 ORIENTATION: Axis a few degrees off E-W, tiers exposed S
 COLLECTIVE SPACE: Streets between rows, Kivas
 DISTANCE BETWEEN BUILDINGS: 20' av.
 BUILDING HEIGHT: 1st-12'-15', 2nd-8'-9', 3rd-8', av. 1 story
 BUILDING MATERIALS: Adobe covered rubble & brick
 ROOF FORM: Flat terraced

On First Mesa in northeast Arizona is the second; the continuously inhabited settlement of Walpi. Atop the jutting escarpment, the settlement of 800 Hopi among the 7,000 along three measas has flourished in continual balance with the water and the land. Rectangular rooms defining several plazas in parallel with the mesas rise vertically at the very edge of the cliff as an extension of its earth and sandstone. Beds of clay between sandstone blocks form walls which are plastered inside and out with a small space always left unfinished. Cottonwood beams often brought from fifty miles distant are placed two feet on center across the side walls. Poles, then sticks and finally trampled mud is applied with

drainage slopes and spouts to collect the water. One corner of the room is left open for a chimney of stacked pots without bottoms. The ceremonial and intensely ritualized kivas are the exception in plan, section and size. They are most often located around one or more plazas as the terrain permits. They are often the largest and the smallest enclosed spaces spanned by arching the blocks and building deeper into the mesa. Entry to a kiva is most always from above, reinforcing the curved or circular plan where there are no corners or niches to suggest a preferred orientation or inequality of presence.

WALPI

LOCATION: First Mesa, NE Arizona

SIZE: 800

FORM: Rectangular rooms parallel to mesa

WATER SUPPLY: 3 springs

ARABLE LAND: base of mesa

ORIENTATION: streets at angle to prevailing wind, NE-SW

COLLECTIVE SPACE: plazas, kivas

BUILDING HEIGHT: 3 story av.

BUILDING MATERIAL: Sandstone, wood, mud

ROOF FORM: Flat terraces

WINDOW: WALL RATIO: 1:10

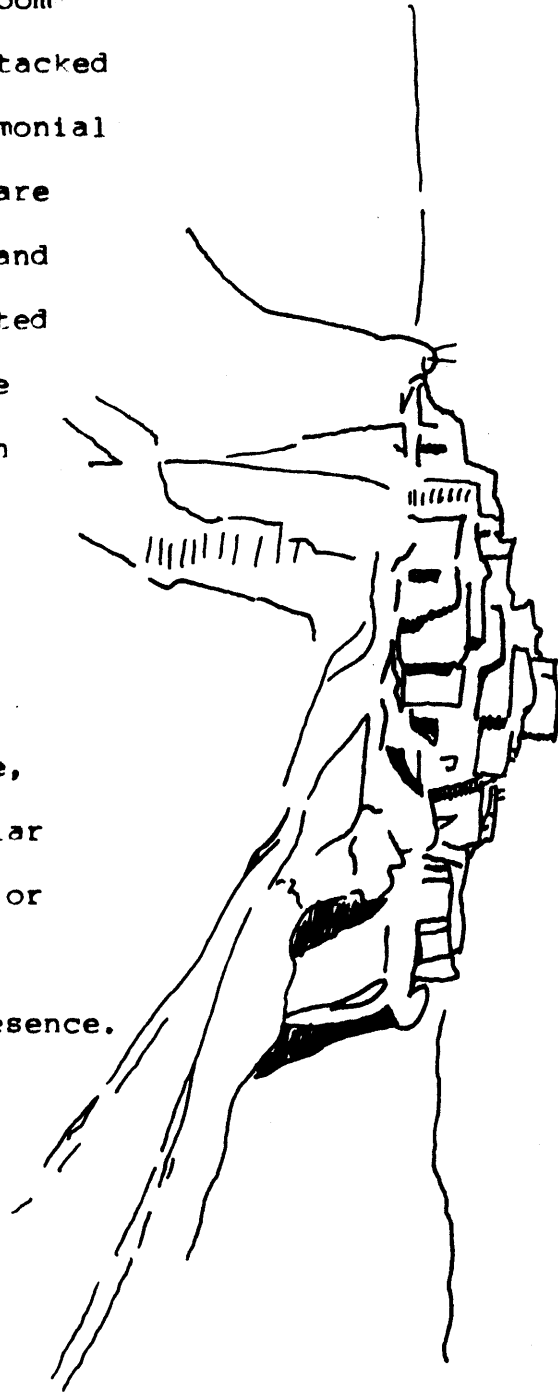





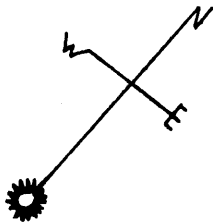

Canyon 4.5

One thousand years ago in an Algerian valley seven towns were founded and built in a total span of forty years. The peninsular plateaus and islands of the valley of the Mzab in Algeria were selected and built according to the ability of the surrounding land of the valley and the sporadic wells to support a maximum population. Dwellings were built of stone, mud and palm wood in repetitive patterns emphasizing variations in internal and external wall surface renderings with river silt and openings of semicircular arches and small rectangular windows. Public or commercial buildings which defined a plaza or market place were an addition of typical dwellings with continuous arcades surrounding the ground level perimeter of

Mzab Valley, Algiers



- Winter town 
- Necropolis 
- Summer town 
- Dam, barrage 
- Trunk road 
- Minor road 

the plaza. Walls of dwellings on the southern slopes of the towns always were built open to the sun while non-south slope dwellings were built with central courts. The towns are also seasonal as most of the town migrates every summer to the cool floodplain of the valley below to set up temporary shelters under the shade of the 180,000 date palms. Here in the floodplain dams were constructed to create surface and subterranean water for the 3000 deep wells of the valley and the irrigation of crops.

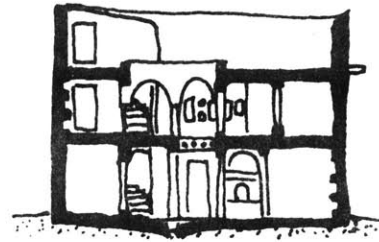

0 — 5m

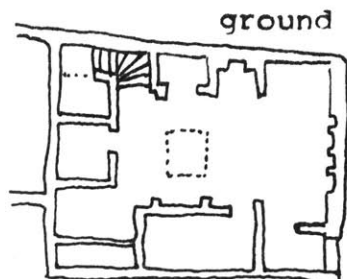
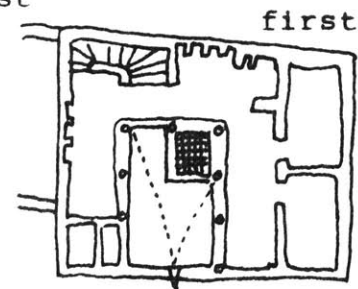
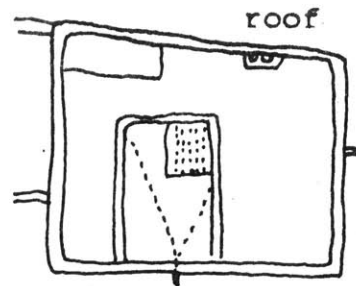

SIZE: 7 towns, 38,000 largest, 2,000 smallest
 FORM: Peninsular or island
 WATER SUPPLY: Wells, cisterns in dwellings
 ARABLE LAND: Floodplain of valley
 ORIENTATION: S & E facing slopes primary
 COLLECTIVE SPACE: plazas
 DISTANCE BETWEEN BUILDINGS: 3 m. av.
 BUILDING HEIGHT: 9 m. av.
 BUILDING MATERIALS: Stone, mud, palm wood
 ROOF FORM: Flat terraces
 WINDOW: WALL RATIO: 1:100 NW wall; 1:4 S wall

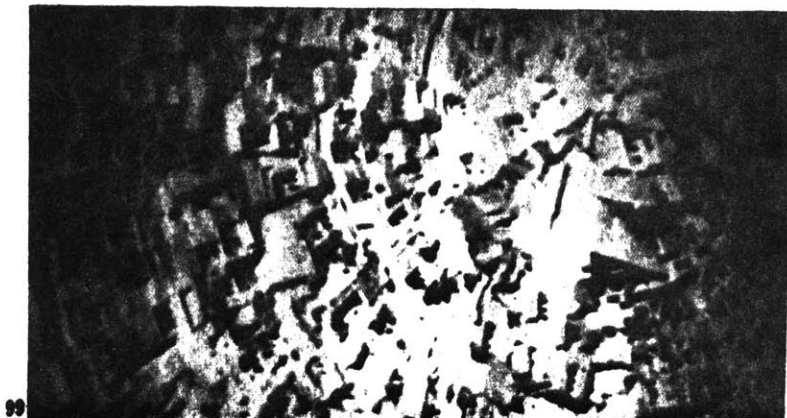

Radial streets of the canyon island city of Ghardaa, Mزاب Valley

Mزاب, Algeria
 well-house

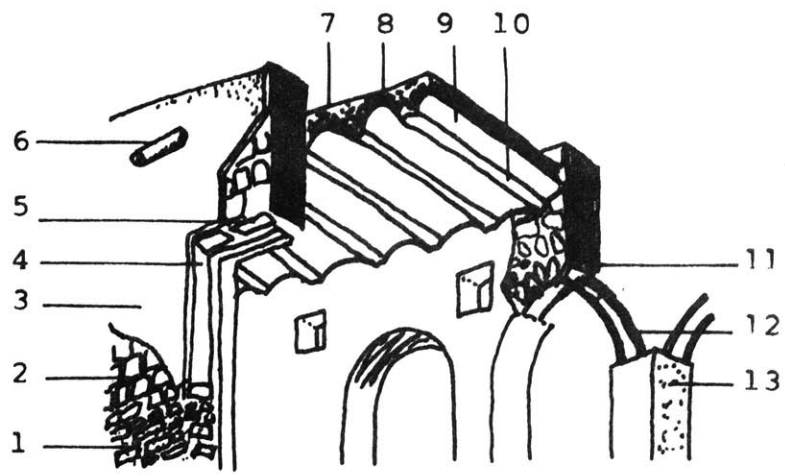

- 1- Masonry foundation and plinth
- 2- Mud block wall (15x15x35cm)
- 3- Rendering colored or natural
- 4- Reveal with smooth rendered finish
- 5- Double palm wood lintel
- 6- Baked clay gargoyle
- 7- Roof covering, timchent
- 8- Stone vaults
- 9- Internal rendering often blue
- 10- Split palm branch, 2m span
- 11- Stone block arch
- 12- Tied and centered palm nervures
- 13- Rendering

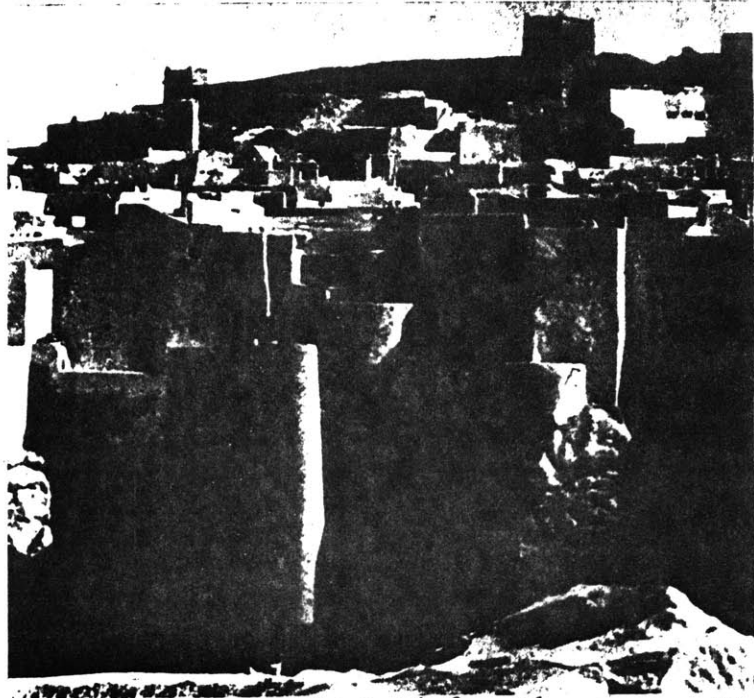

Northwest wall Bura Nura

One hundred feet from the cliffs of Chaco Canyon in northwestern New Mexico a curved terrace was built along a southern slope facing southeast. During the next one hundred and fifty years the curve was completed into a semicircular terraced crescent with exposures to the south, southeast and southwest. Growing to a total height of twenty-nine feet with an average depth of thirty-seven feet, the population at the pueblo's peak is estimated at 1,200. Less than fifty years after the completion of the crescent the pueblo was abandoned. As the settlement was clearly sited for both its slope and availability of water so it would not be surprising to suspect the elimination of their water supply. A probable ultimate cause could have been the resident's clearing of forest land in the upper canyon for lumber

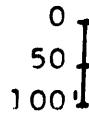
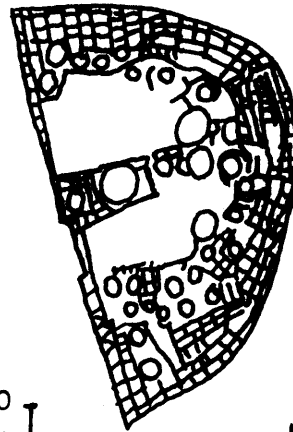

Pueblo Bonito
36°N
5000' ele.

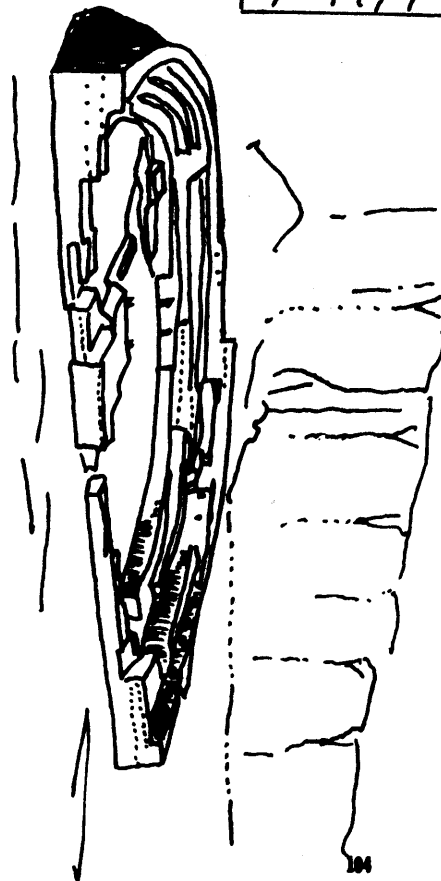

creating erosion and runoff to drastically increase. And as runoff increases, return to a groundwater aquifer will decrease; the consequently dry wells of the pueblo would allow few alternatives.

PUEBLO BONITO

LOCATION: Middle NW New Mexico, 36°N. Lat., ele. 5000'
 SIZE: 1,200 in 800 rooms; 300' across, 120' from opening to
 outside of curving walls on north
 FORM: Crescent with tiers, semicircular plan
 WATER SUPPLY: Wells
 ARABLE LAND: Land to S of settlement
 ORIENTATION: S, highest building in crescent faces SE
 BUILDING HEIGHT: 1st-10.3', 2nd-9.4', 3rd-9.4', total-29.1'
 BUILDING MATERIALS: Rubble adobe for wall core, sandstone finish,
 Pine beams, mud floors
 ROOF FORM: Flat Terrace

Arcosanti is a settlement of students, craftsmen and builders working together for the past six years under the direction of Paolo Soleri to create an autonomous city of concrete and steel rising twenty-five floors above a canyon near Cordes Junction, Arizona. Presently all structures rise no more than 3 stories with the most habitable spaces during the full year existing adjacent to the ceramic and metal apses, surrounded partially by

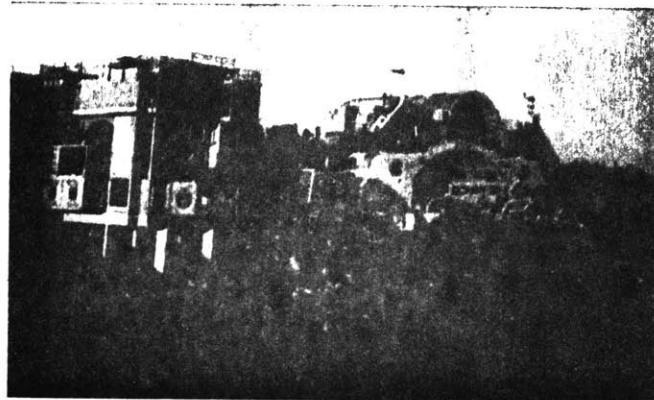

earth with their openings facing south and east. The present designs diagram enormous heat storage, wind channelling, access, greenhouse and common spaces with few details of how these collective spaces actually operate. The response of residents to the present designs is that the technology is not yet ready to make the design a reality. Unavoidably the propositions of immense singular forms to enclose a multitude of centralized community utilities and useable spaces creates an unending demand for high energy, complex solutions. The problem as presented to provide a self-sufficient, ecologically balanced, awe-inspiring environment for two thousand needs to be first understood in terms of the low energy simplicity with which the awe-inspiring canyon settlements of Pueblo Bonito and the valley of the Mzab were built a thousand years ago. And yet, the megastructure Arcosanti is not built; only contrasting clusters of low energy structures, the evidence of a slow and continual redesign, have been and may continue to be, built.



LOCATION: Cordes Junction, AZ., $34^{\circ}18'N$, $112^{\circ}10'W$, 4000' ele.
SIZE: Permanent 40, proposed 2000 on 1% of Cosanti preserve
 860 acres or 8-9 acres
FORM: Partial pyramid section, one-third circle plan, present
 growth around $\frac{1}{2}$ spheres-apses
WATER SUPPLY: Spring, cisterns collect runoff from structures
ARABLE LAND: Proposed use of S canyon wall beneath city as
 multiple greenhouses
POWER: Solar collection, wind
ORIENTATION: SE,S,SW; E-W axis parallel to canyon
COLLECTIVE SPACE: Ceramic apses, entry vaults, proposed open
 void within pyramidal structure
DISTANCE BETWEEN BUILDINGS: 25' av.
BUILDING MATERIALS: Concrete, wood, steel
ROOF FORM: Reinforced concrete gable - proposed 25 story hldq..
WINDOW:WALL RATIO: 1:3 - present built space
SHADING: None present

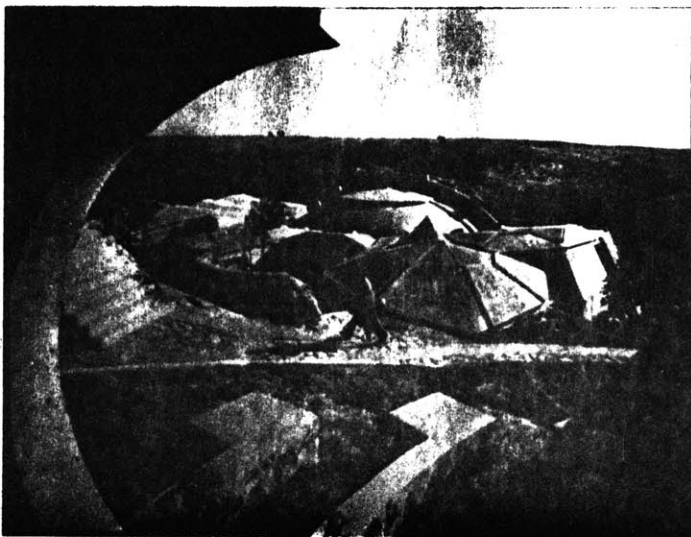

107

Dwellings surrounding Ceramics Apsa



108

Plain 4.8

In the plains of southern Morocco, the typical response to the desert environment has been the ksar. The ksar is a village built of loam within perimeter fortification walls and high crenelated towers. One entrance facing east leads into a narrow main street of the village usually oriented east - west. Nearest the entrance are the most collective spaces of the mosque, a bathhouse and/or koran school. Secondary streets or side alleys connect the main street at right angles and provide the entrance route into the ksar house. The house usually has a base of 150 to 250 meters square. It is built on a stone foundation of 80 centimeters in height with 50 centimeters projecting above the grade as a damp course. Sun baked loam bricks, (40cmx20cm x 10 cm.),



or monolithic loam packed into wood forms, 80-90 cm. high continue the bearing walls up two stories to a parapet at roof level. Flat floors and the roof are constructed with wood beams and mud, the standard length of available wood determining the usual 2.5 to 3 meter depth of rooms. The number of central columns which support a ceiling around a square courtyard opening in the ksar house indicates the size of a house. The smallest of four columns determines a courtyard of 6 meters square while the very large 12 to 16 column house determines courtyards of 50 to 100 meters square.

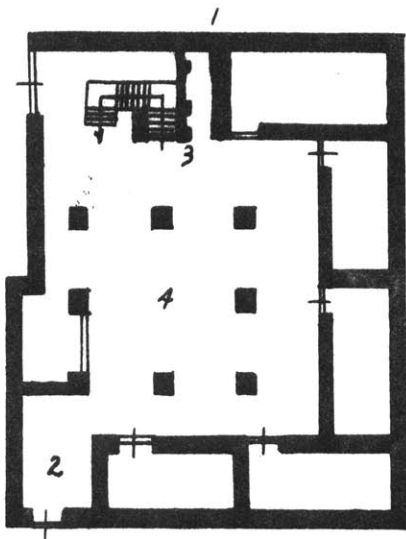

1. Neighboring dwelling
2. Hall
3. Toilet
4. Patio

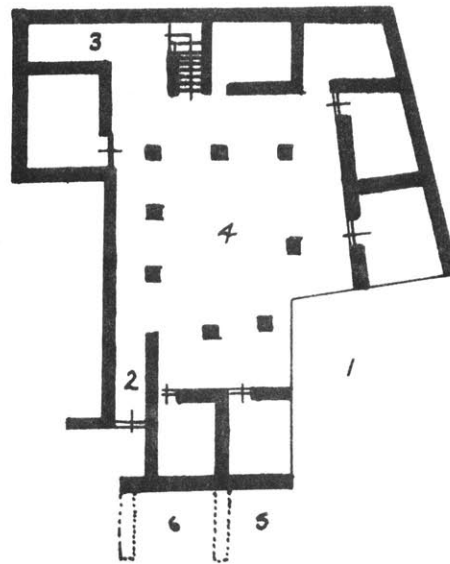

1. Neighboring dwelling
2. Hall
3. Toilet
4. Patio
5. Alley
6. Room above Alley

Ksar dwellings - Figuig

FIGURE

LOCATION: Valley of Zousfana, Morocco
 SIZE: 7 ksar, 40 residents
 FORM: linear
 WATER SUPPLY: Balance well
 ARABLE LAND: Irrigated oasis, lower than bldgs.
 ORIENTATION: South
 BUILDING HEIGHT: 9.5 m
 BUILDING MATERIAL: Loam, wood
 ROOF FORM: Flat terrace
 WINDOW:WALL RATIO: 1:18

COVERED PART
 OF ALLEY
 BUILDING

North

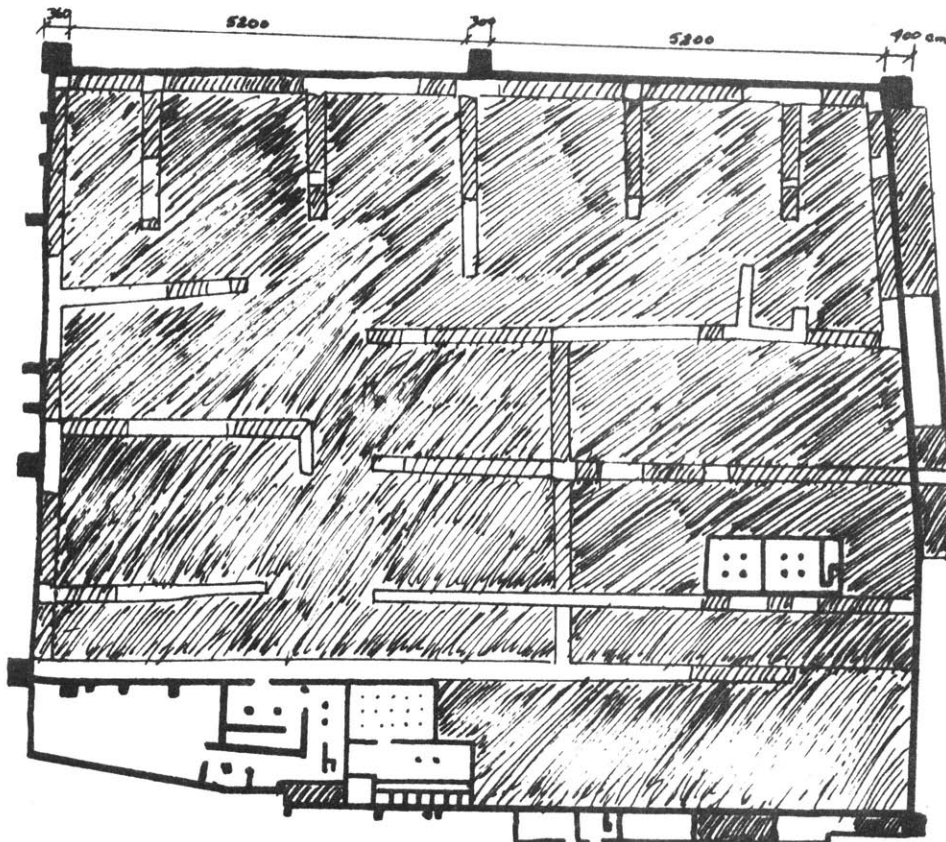

Ait Ben Mohammed Plan

AIT BEN MOHAMMED

111

LOCATION: Past Zagora, near valley of Dra, edge of Sahara
 SIZE: 20,000, 120x95m, 111 dwellings, 98 dwellings/hectare
 WATER SUPPLY: hundreds of balance wells
 ARABLE LAND: 300,000 date palms, walled fields around ksar
 ORIENTATIONS: Alley E-W most important, doors E-W
 COLLECTIVE SPACE: Bathhouse, Koran school, mosque, entrance
 DISTANCE BETWEEN BUILDINGS: 2 m alley
 BUILDING MATERIALS: loam, wood
 ROOF FORM: Flat terraced
 WINDOW:WALL RATIO: 1:40

AIT ATTO

LOCATION: Ziz Valley, region past Rich
SIZE: 70x70 m, 20 dwellings
FORM: Square plan double enclosing wall
ORIENTATION: Main alley E-W
COLLECTIVE SPACE: Mosque inside gate
DISTANCE BETWEEN BUILDINGS: alley 2m
BUILDING HEIGHT: 2 story
BUILDING MATERIAL: red loam, wood

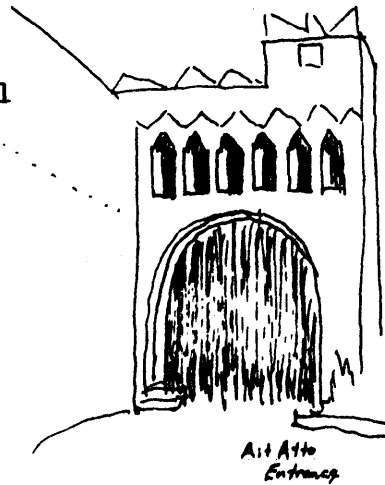
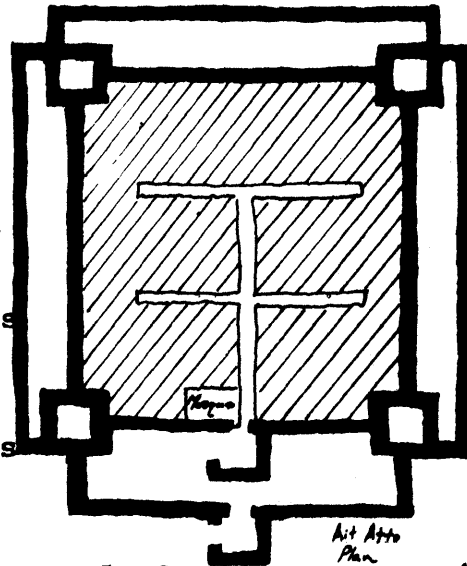
Ait Atto
EntranceAit Atto
Plan**EL HARTE**

LOCATION: Dades Valley not far from
Boulmalne
SIZE: greatest width 44m, least
26m, length 115m; 42 dwellings
110 dwellings/hectare
FORM: bent C, not rectangular
WATER SUPPLY: well, Dades river
ARABLE LAND: Olive trees, date palms
COLLECTIVE SPACE: entrance, mosque,
koran school

DISTANCE BETWEEN BLDs.: 2-3m
ORIENTATION: Parallel to river, open end of C
to SE, long axis NE-SW, alleys parallel to axis
BUILDING HEIGHT: 2 story av.
MATERIAL: Loam, wood
ROOF FORM: Flat terraced
WINDOW: WALL RATIO: 1:40

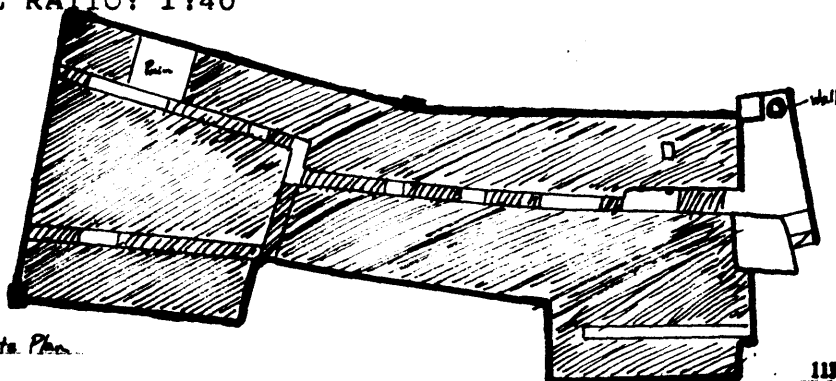

El Harte Plan

OULED LIMANE

152

LOCATION: Valley of Ziz
SIZE: 100x125m, 107 dwellings,
 86 dwellings/hectare
ORIENTATION: SW entrance, main
 street SW-NE
COLLECTIVE SPACE: Square 400 cm²
 Bathhouse 3m², Koran school 3m²
DISTANCE BETWEEN BLDs.: 2.5-3m
BUILDING HEIGHT: 9.6m av.
MATERIALS: Loam, wood
ROOF FORM: Flat terraced
WINDOW:WALL RATIO: 1:25

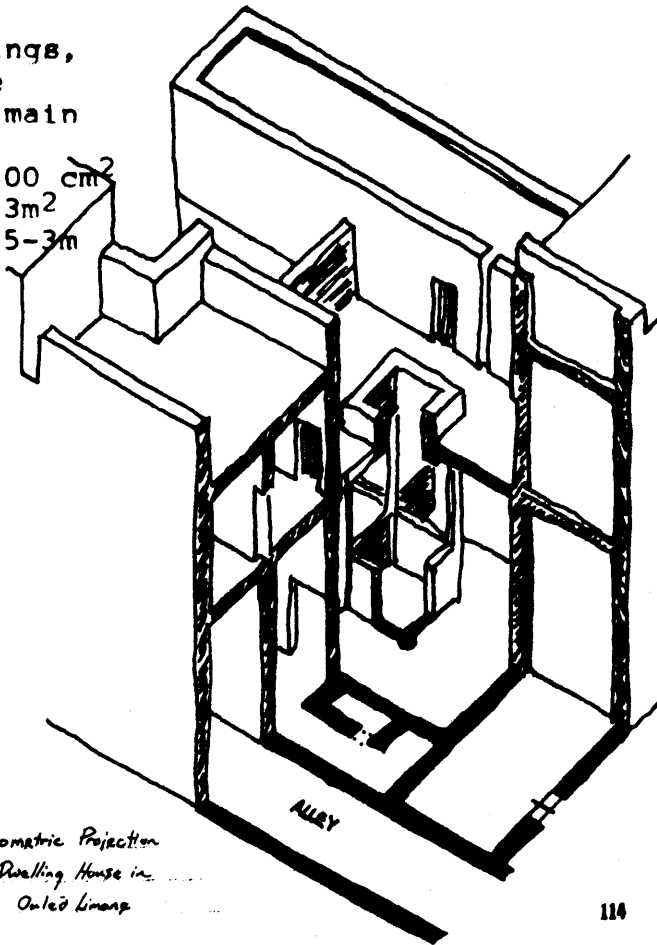

*Isometric Projection
 Dwelling House in
 Ouled Limane*

114

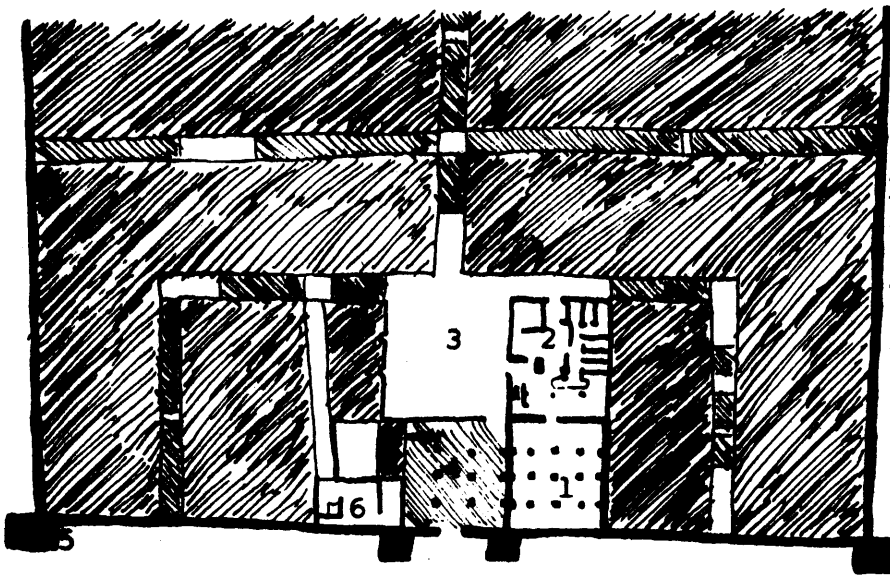

- 1. Mosque
- 2. Bathhouse
- 3. Square
- 4. Entrance
- 5. Tower
- 6. Stock



covered alley houses

Partial Plan Ouled Limane

115

TINERHIR

LOCATION: West end Valley of Dades
FORM: perimeter ring around oasis
ARABLE LAND: Amid the forest of palms
 interior to settlement
ORIENTATION: circular around oasis
COLLECTIVE SPACE: oasis
DISTANCE BETWEEN BLDS: 2m
BUILDING HEIGHT: 3 story
BUILDING MATERIAL: red loam, rubble
ROOF FORM: Flat with terraces
WINDOW:WALL RATIO: 1:18
SHADING: wood screens, shutters

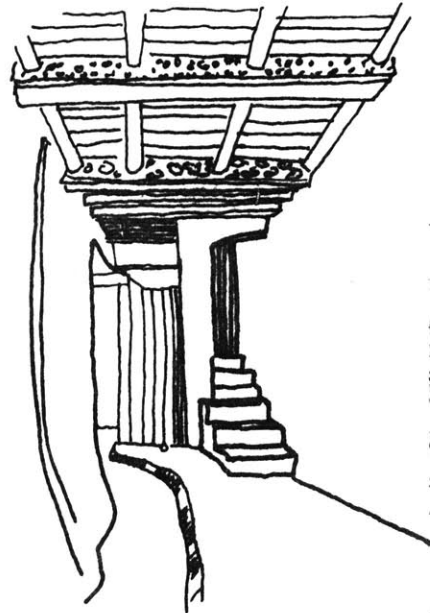

Tinerhir

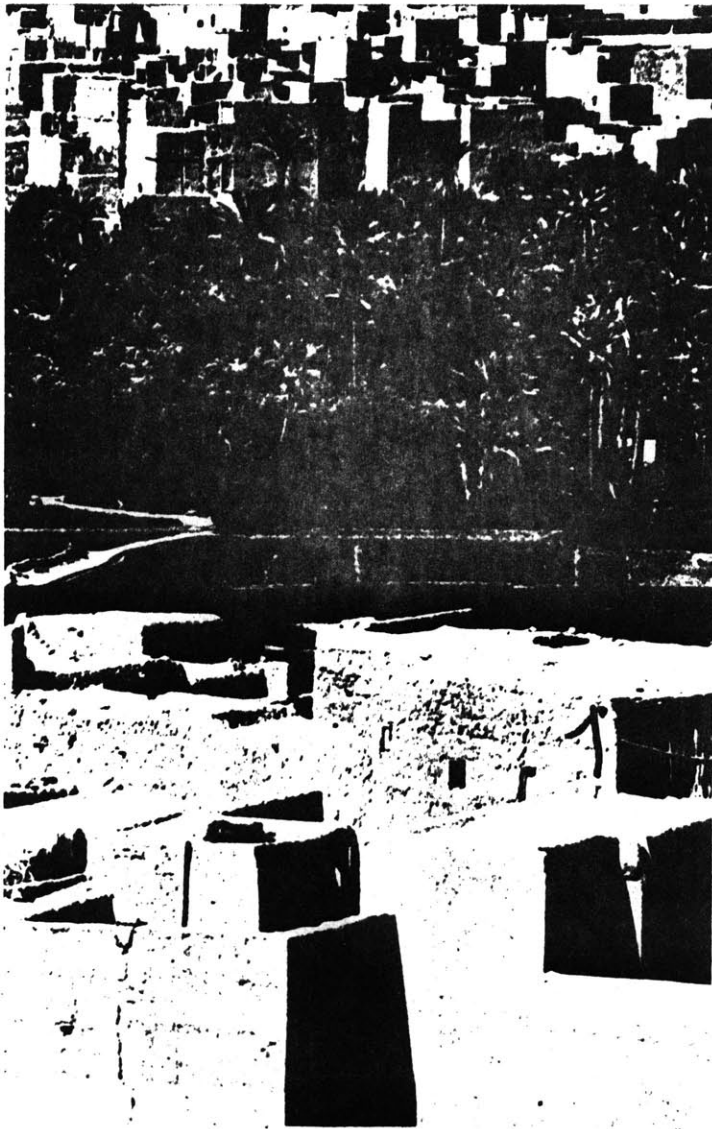

116

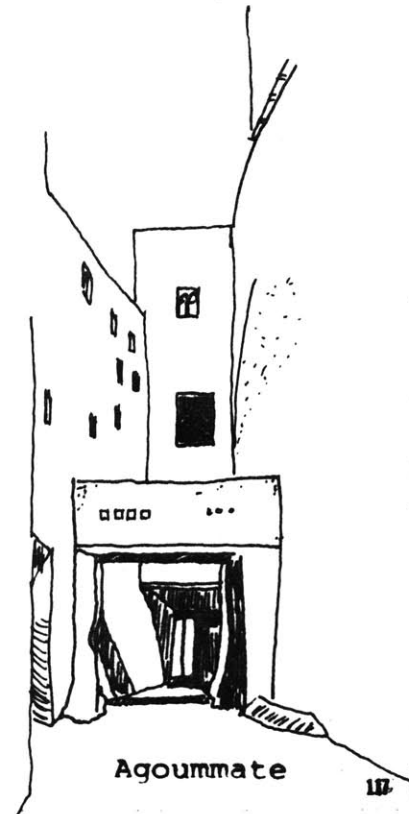

Agoumate

117

TADOUA

-  Roof above 1 story
-  Roof above 2 stories
-  Roof above 3 stories
-  Roof above 4 stories
-  Roof above 5 stories
-  Alley
-  Well
-  Steep Slope
-  Rock
-  Ovens

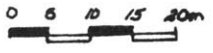
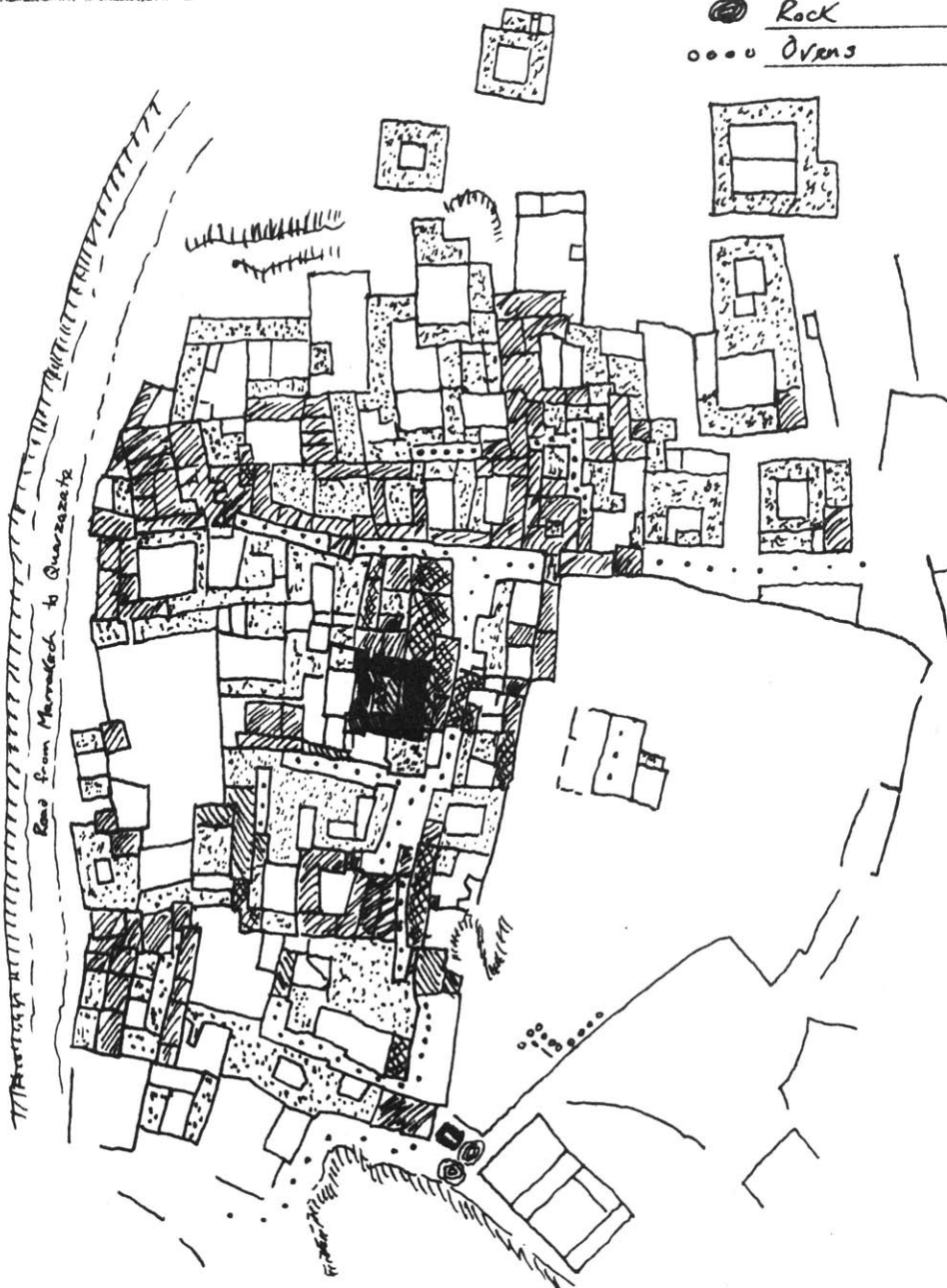

TABOULA

LOCATION: 30 km from Quarzazate, edge of Sahara

SIZE: 200 dwellings, 120m N-S, 75m E-W

FORM: Expansion around tigrament/castle to center

WATER SUPPLY: 1 well

ARABLE LAND: South of village are fields, village site
chosen on land not suitable to farm

ORIENTATIONS: Mountains to NW; largest open defined space SE;
access road on W & N ; highest building adjoins open
space to S, SE or E

COLLECTIVE SPACE: Entrance on E & S ; alley intersection $50m^2$
width 2x normal alley dimension; 80% of defined interior
courts adjoin another interior court; only courts
adjoining an alley are those of collective buildings -
mosque, koran school near E entrance

DISTANCE BETWEEN BUILDINGS: 1.5 - 2.5 meters

BUILDING HEIGHT: 1-5 stories, 2 average, 2%-5 story, 5%-4,
10%-3, 38%-2, 45%-1

BUILDING MATERIALS: Loam, wood, clay plaster

ROOF FORM: Flat terraced

WINDOW:WALL RATIO: 1:20

SHADING: Wood screens, panels, shutters, overhangs for
interior courtyard balconies

The medina of Morocco developed not from the gradual enlargement of ksars and small villages but from the presence of a foreign ruler confirming authority. Not surprisingly the medina is divided into districts; the kasba palace of the sultan, the mellah quarter for the Jewish, the ville nouvelle of the French or Spanish, the bidonville shanty town and the native village. The primary organization of the medina is found in the native village which has a mosque or mosques as clear centers. Main streets radiate from the center to main gates in a city wall flanked by the medinas leading shops. Right angles and clear coordinates for streets hardly exist at all beyond the radial

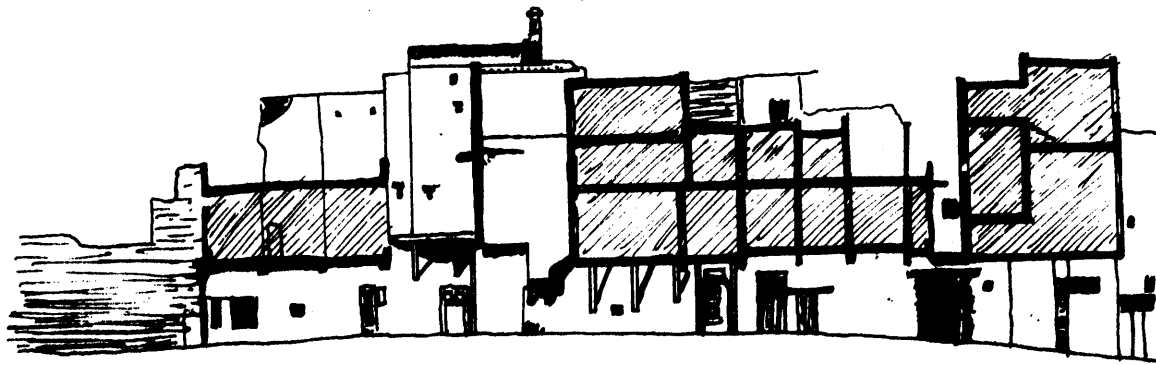

Section commercial alley Derb Rabat et-Tben, Fes

119

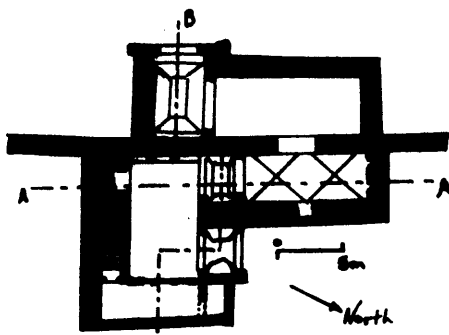

Marrakech towngate Bab el Dabagh

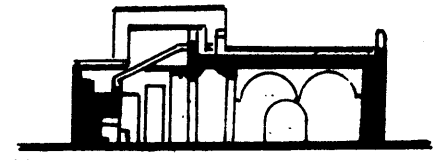

AA



120

pattern. Similar to the ksars the streets are narrow with most dwellings only open on one of four sides and rising an average of two stories with few differences in height. Fes el-Bali the typical Arab medina, is constructed of fired brick while the medina of Rabat is built of stone and Marrakech primarily of loam.

FES

LOCATION: central Morocco

SIZE: 250,000, 15/dwelling

FORM: Radial concentric

WATER SUPPLY: 2 rivers, wells

ARABLE LAND: gardens SW of city

POWER: electricity, coal

ORIENTATION: main streets E-W

COLLECTIVE SPACE: streets, mosques

DISTANCE BETWEEN BLDs.: alley width 2.2m

BUILDING HEIGHT: 3 floor av.

MATERIAL: Brick

ROOF FORM: Flat

WINDOW:WALL RATIO: commercial 1:3,
residential 1:10

SHADING: overhangs, shutters, screens

Streets-medina of El Jadida

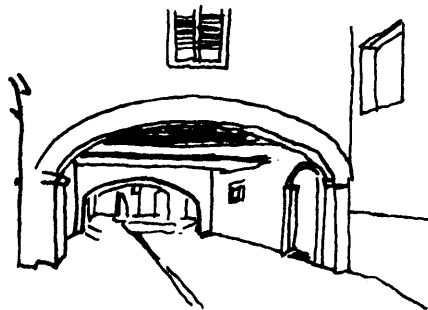
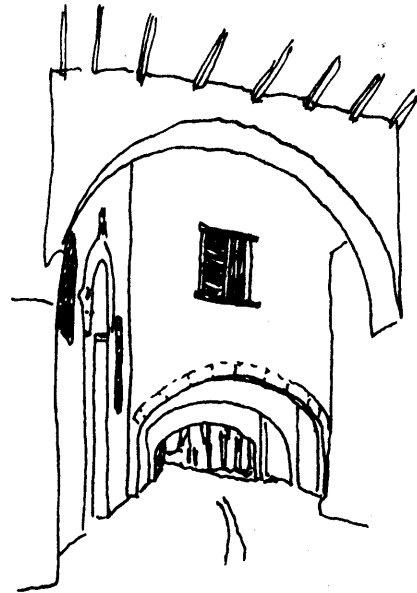

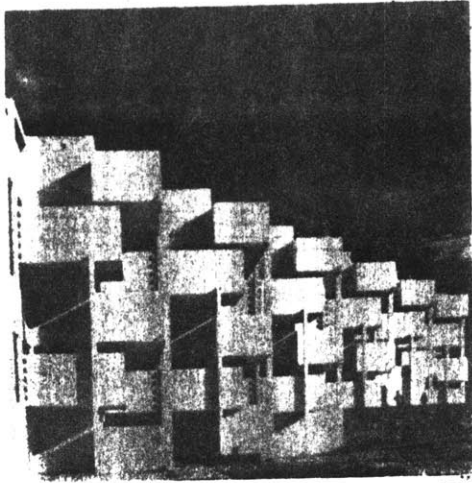

122

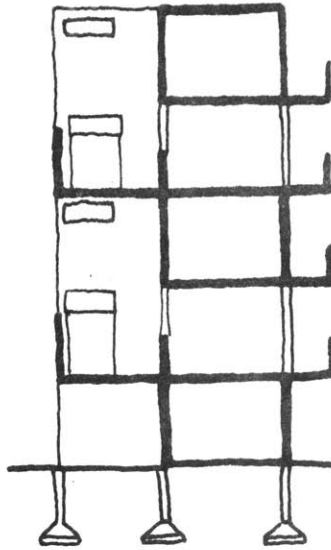

Apartment Casablanca (1951 Andrez Skider, ATBAT)

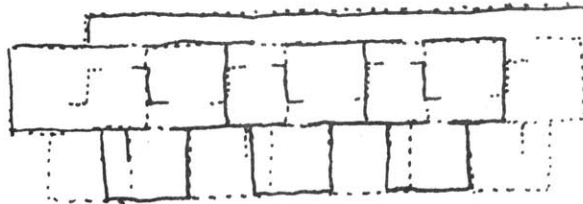

123

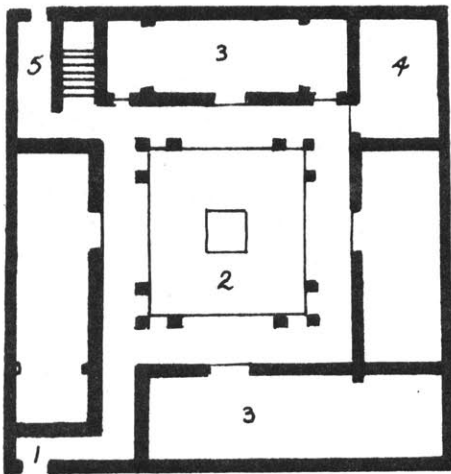

Typical medina townhouse, Morocco

- 1. entrance
- 2. patio
- 3. rooms
- 4. kitchen
- 5. waste closet

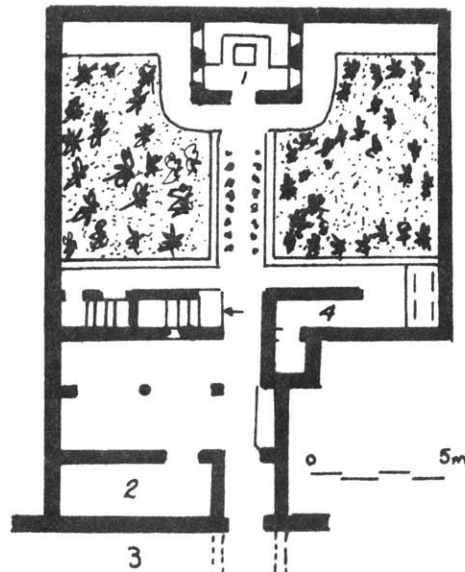

Riad in Rabat, Morocco

- 1. Pavilion
- 2. Kitchen
- 3. Alley
- 4. Waste closet

The new cities of Australia's inland northern territory and the southwestern U.S. are examples of attempts to compress thousands of years of adaptation to this climate into air conditioned frame structures. The ease of mobility into these lands has allowed the temperate region dwelling and street patterns to be transferred without alteration into a drastically different environment. Defined open space in relation to built space is far too large for spaces interior or exterior to benefit from the extensive, repetitive dwellings. Roads, even local ones used for light traffic only are extremely wide with sidewalks and typically yellow and dry attempts at lawns separating the structures. Dwellings are typically built on grade concrete slabs with 2x4 stud wall and gable roof framing to shed non-existent rainfall and allow immense heat gains from expansive glass areas usually curtained in a last ditch attempt to lower cooling bills. Developers/architects in their flurry to



Tennant Creek, Australia

LOCATION: Tennant Creek, Northern Territory Australia
 SIZE: 200 dwellings
 FORM: rows parallel to main street
 WATER SUPPLY: wells
 ORIENTATION: main road N-S
 COLLECTIVE SPACE: store
 DISTANCE BETWEEN BUILDINGS: 120' access road, 20' adjacent
 BUILDING HEIGHT: 15'
 BUILDING MATERIALS: Wood frame, plywood frame, steel decking
 ROOF FORM: Gable
 WINDOW:WALL RATIO: 1:4

attract the dense populations of the east and midwest U.S.
 seek to further minimize basic differences by building
 large lakes and ponds amidst 'continental villas' (figure 116)
 which evaporate more water in one year than falls in ten.

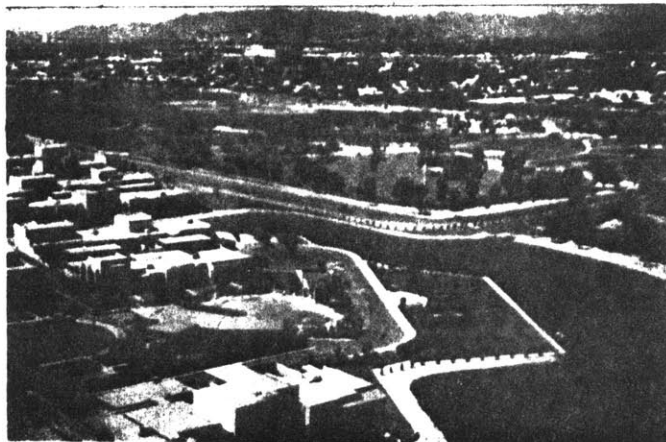

Continental Villas East - Scottsdale, Arizona

Bariz is a new city built six kilometers north of an ancient Bariz at an oasis in the western desert of Iran. Initiated fifteen years ago under the direction of Hassan Fathy, the city was designed to respect the traditions of cities built and continuously inhabited in the region for 1,600 years. Fathy references his designs to the neighboring city of Bagwat built entirely of material found on the site and the ruin of old Bariz with its traditional patterns and structures, narrow winding streets and houses oriented inwards. Since there are no plans of old Bariz or of any other village or town in the region, Fathy chose the similar image of a

Plan - Bariz, Iran



Tunisian desert village to organize the site plan of the new Bariz.

SIZE: 250 families

FORM: squares of neighborhoods with NE corners cut in a response to contour

WATER SUPPLY: well capable of irrigating 1,000 acres

ORIENTATION: major streets E-W & N-S, diagonals NW-SE

COLLECTIVE SPACE: 16'x22' alley openings

DISTANCE BETWEEN BLDs.: alley 6'

BUILDING HEIGHT: 2 stories

MATERIAL: stoccoed brick

ROOF FORM: Flat, vaults

WINDOW:WALL RATIO: 1:8

SHADING: wood screens

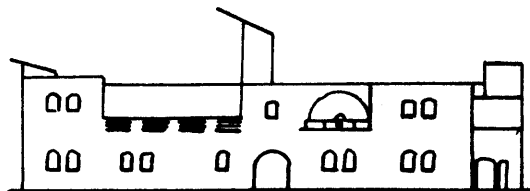
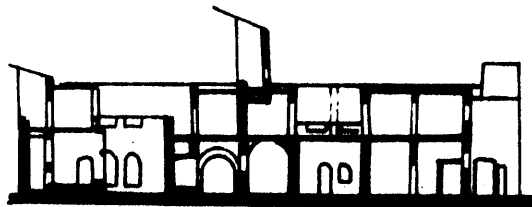
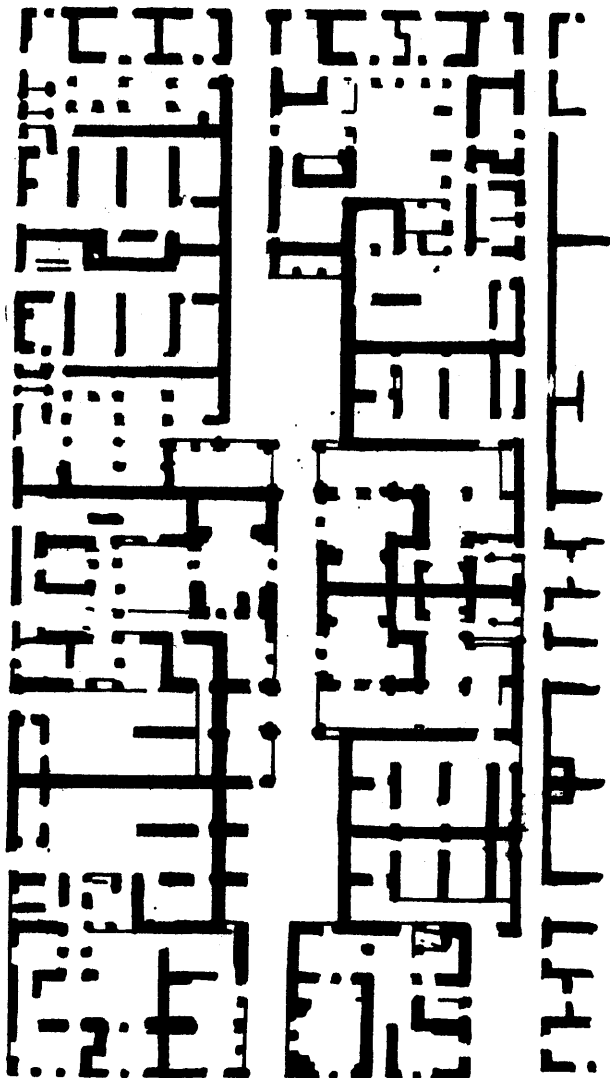

Precedent Summary 4.7

The following table is a summary of the desert settlements researched. Their characteristics are abbreviated as follows:

- SIZE:** Population estimate or number of dwellings x4
- (W) **WATER SUPPLY:** W-well; R-runoff; S-stream or open body of water; C-cistern
- (A) **ARABLE LAND:** one of 8 compass points from settlement
- (O) **ORIENTATION:** of 8 compass points perpendicular to main street or axis
- (C) **COLLECTIVE SPACE:** ~~Average~~ circulation intersection size, ft²
- (D) **DISTANCE BETWEEN BUILDINGS:** Average, ft
- (H) **BUILDING HEIGHT:** Average, story or ft.
- (M) **BUILDING MATERIAL:** Primary - W-wood, L-loam, B-brick, S-stone, C-concrete
- (R) **ROOF FORM:** Primary - F-flat, V-vaulted, G-gable
- (WW) **WINDOW:WALL RATIO:** Average maximum on a single exposed wall
- (S) **SHADING:** Primary - S-screens, D-shutters, C-curtains, O-overhang
- PREDOMINANT:** Decisions most frequent among all settlements presently occupied and past their bicentennial (*)

	Size	W	A	O	C	D
1. Matmata*	2,000	W	-	up	1000	0
2. Montezuma	60	S	S	S	-	0
3. Ain Leuh*	-	SE	S	S	100	11.5
4. Ourika Valley*	50	-	SE	SE	300	6
5. Tizi-n-Tichka*	100	-	S	S	360	10
6. Zaouia Ahansal*	50	S	S	S	-	-
7. Ait Abdarahim*	100	W	S	S	60	5
8. Metameur*	-	-	-	-	150	15
9. Ait Benhaddou*	200	W,R	S	S	120	10
10. Jaisalmer*	40,000	S	SE	NE	215	8.2
11. Takrouna*	400	-	N	E	40	10
12. Acoma*	800	-	-	S	500	20
13. Walpi*	800	S	S	SE	-	-
14. Mزاب*	72,000	W,C	all	all	-	9.8
15. Bonito	1,200	W	S	S	-	-
16. Arcosanti	2,000	S	S	S	509	25
17. Fiquiq*	40	W	-	S	-	6
18. Ait Ben Mohammed*	20,000	W	-	S	43	6.6
19. Ait Atto*	80	-	-	E	43	6.6
20. El Harte*	168	W,S	all	SE	67	8.2
21. Ouled Limane*	428	-	-	SW	79	8.9
22. Tinerhir*	-	S	all	all	-	6.6
23. Tadoula*	800	W	S	S	538	6.6
24. Fes*	250,000	W,S	SW	S	97	7.2
25. Tennant Creek	800	W	-	all	2400	40
26. Phoenix	800,000	W,S	SW	all	3600	40
27. Bariz	1,000	W	-	S	352	6
PREDOMINANT*		W	S	S	232	9.9

	H	M	R	WW	S
1. Matmata*	20'	S	V	-	-
2. Montezuma	50'	S	F	-	O
3. Ain Leuh*	21'	S	F	1:14	S
4. Ourika Valley*	2 story	S	F	1:8	O
5. Tizi-n-Tichka*	2 story	S	F	1:8	O
6. Zaouia Ahansal*	2 story	S	F	1:40	-
7. Ait Abdarrahim*	3 story	L	F	1:15	-
8. Metameur*	3 story	S	V	-	D
9. Ait Benhaddou*	24'	L	F	1:20	-
10. Jaisalmer*	3 story	S	F	1:16	S
11. Takrouna*	1 story	S	V	1:20	-
12. Acoma*	15'	S	F	-	-
13. Walpi*	3 story	S	F	1:10	D
14. Mzab*	29.5'	S	F	1:50	-
15. Bonito	29.1'	S	F	-	-
16. Arcosanti	250'	C	G	1:3	O
17. Figuiq*	31.2	L	F	1:18	-
18. Ait Ben Mohammed*	2 story	L	F	1:40	-
19. Ait Atto*	2 story	L	F	-	-
20. El Harte*	2 story	L	F	1:40	-
21. Ouled Limane*	31.5'	L	F	1:25	-
22. Tinerhir*	3 story	L	F	1:18	D
23. Tadoula*	2 story	L	F	1:20	D
24. Fes*	3 story	B	F	1:10	D
25. Tennant Creek	14'	W	G	1:4	C
26. Phoenix	14'	W	G	1:2	C
27. Bariz	2 story	B	F	1:8	S
PREDOMINANT*	3 story	S	F	1:20	D

The predominant decisions most frequent among all settlements researched presently occupied and past their bicentennial are:

- Water Supply** - Wells and therefore groundwater supplies most potable water.
- Arable Land** - Arable land is primarily to the South of a settlement.
- Orientation** - Settlements are primarily oriented with their major axis perpendicular to the South.
- Collective Space** - The average size of intersections of internal circulation paths is 232 ft.²
- Distance Between Buildings** - The average distance between buildings is 9.9 feet.
- Building Height** - The average maximum building height is three stories.
- Building Material** - All settlements are built primarily of masonry; the primary masonry material is stone.
- Roof Form** - All roofs are either flat or vaulted; flat roofs are most common.
- Window;Wall Ratio** - Windows are on the average one-twentieth of exterior exposed wall areas.
- Shading** - The most common shading devices are shutters and doors.

The comparable decisions derived in this thesis through analysis of the ecological characteristics of the site in north central Arizona are:

- Water Supply** -- Runoff of drainage basins should supply potable water and determine settlement size for there is no groundwater available.

- Arable Land** - Arable land should exist within one mile of buildable land.
- Orientation** - Settlements should be oriented to 25 degrees east of South. Sites located above the transition zone, on the mesas or the mountains should be oriented 20 degrees east of South.
- Collective Space** - The optimum size for collective space or circulation intersections was not determined.
- Distance Between Buildings** - The distance between buildings should be narrow; the minimum should allow walking access.
- Building Height** - Dwelling spaces should be located close to the ground to decrease evaporation and increase natural shade. Some built connection should exist to higher levels to benefit from the increased ventilation provided by the wind. Underground construction should be used when possible to benefit from the low and stable earth temperatures. Building height should be low to allow a minimum of required energy for access within a building. Enclosed spaces should have high ceilings and upper ventilation to allow the hotter air to rise away from use levels.
- Building Material** - The most convenient and ecologically balanced building materials for use in this region are the earth and rock existing at the site.
- Roof Form** - Vaults and domes are most appropriate to this site due to the prevalence of compressively strong masonry material. Since there is little need for shading frequent rain or snow or collecting solar energy for space heating, a pitched roof is not suitable. The more simple flat roof should be the secondary roof structure. The flat roof also allows the enclosed water pond roof system to provide yearly internal temperatures between 66°F and 74°F.

Window:Wall Ratio - It is appropriate to have as few openings as possible and only in directions allowing increased comfort to the interior. Prevailing winds of east, southwest and southeast depending on location of a site in the region determine openings for direct ventilation. Maximum beneficial gain in the winter months to the southeast determines openings for space heating. High temperature air at ceilings and the need for even quality of natural space lighting determines openings around the edge of a roof.

Shading - Shading devices should be constructed of materials with low heat storage capacity. Shading should be designed for particular opening heights and orientations. Screens provide a subdued contrast between the darkness of an interior and the daylight. Finer screen mesh near the ground and the use of curved bars for a screen will decrease glare and increase the quality of entering light.

TWIN COVE

Larry Creek is an intriguing east-west branch of the Agua Fria River. Rising 800 to 1000 feet above the creek, canyon walls of a thirty percent average slope envelope the basin. Fingers of Perry Mesa, on the north, interlock the abrupt slope of the canyon edge in east-west and north-south side canyons and hollows.

The site (figures 129-131) was selected for a settlement of 400 people determined by the following criteria:

1. Buildable Land; 3.1; Map 20
2. Arable Land; 3.2; Map 26
3. Settlement Size 400; 3.3 pg.90
4. Orientation South-Southeast; 3.4
5. Location near canyon edge to increase ease of access and increased perceived building height; 3.6
6. Location in hollow or natural land protection form; 3.7

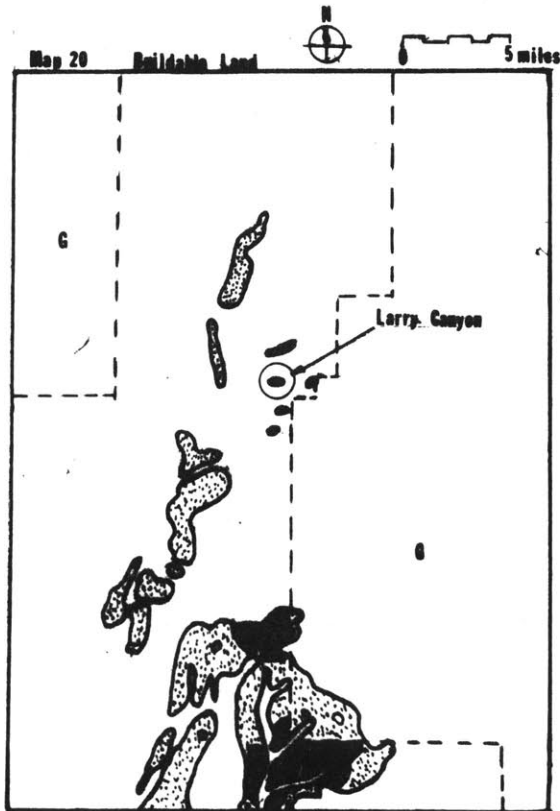

KEY
 [Stippled Box] Buildable
 [Solid Black Box] Most Buildable
 G National Forest

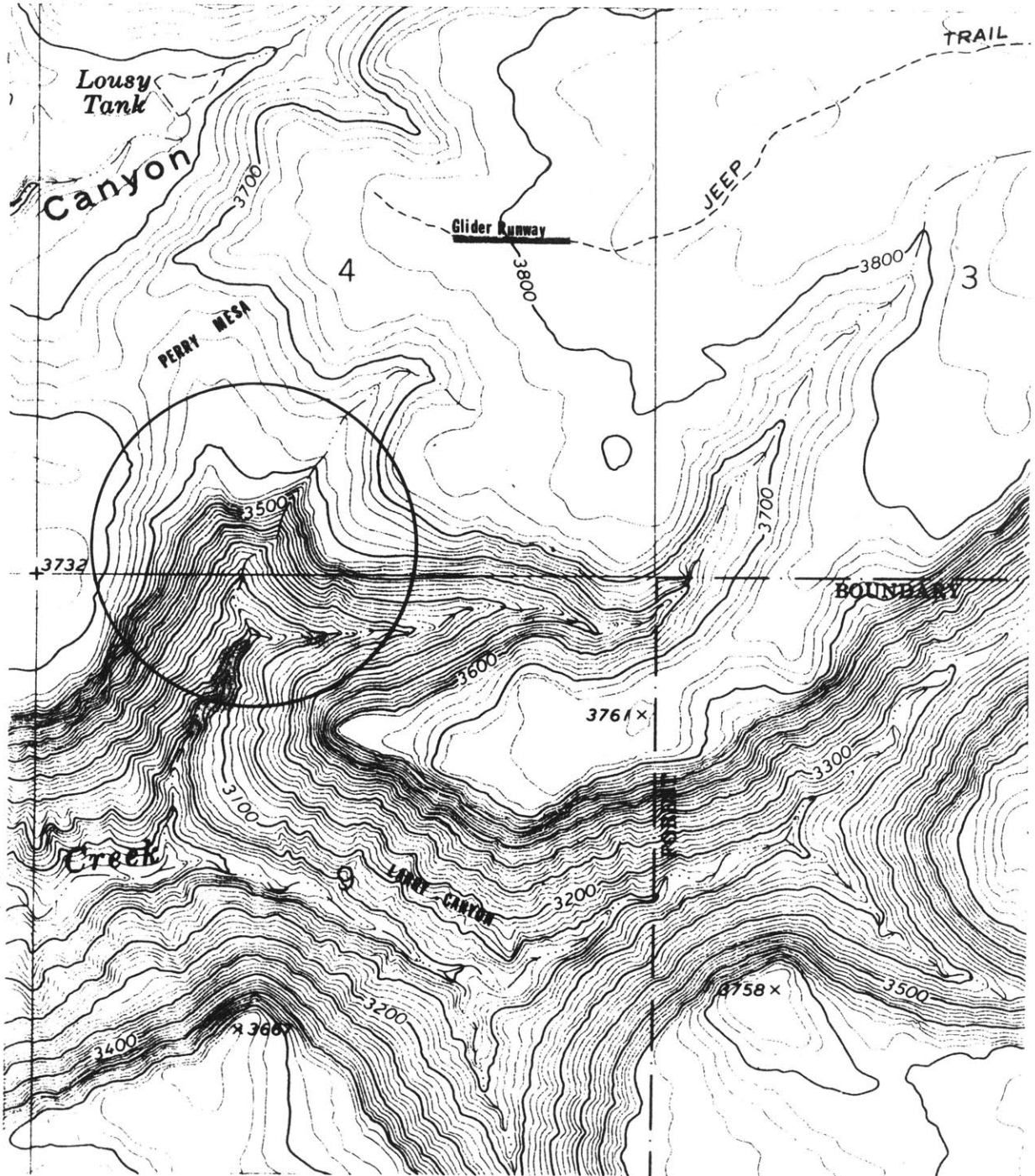
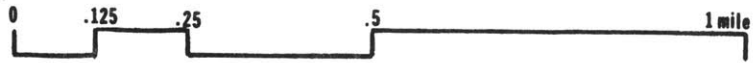

Site of Twin Cove Larry Canyon, Arizona

0 100 500 ft. 1000
- Contour interval 20 Feet -

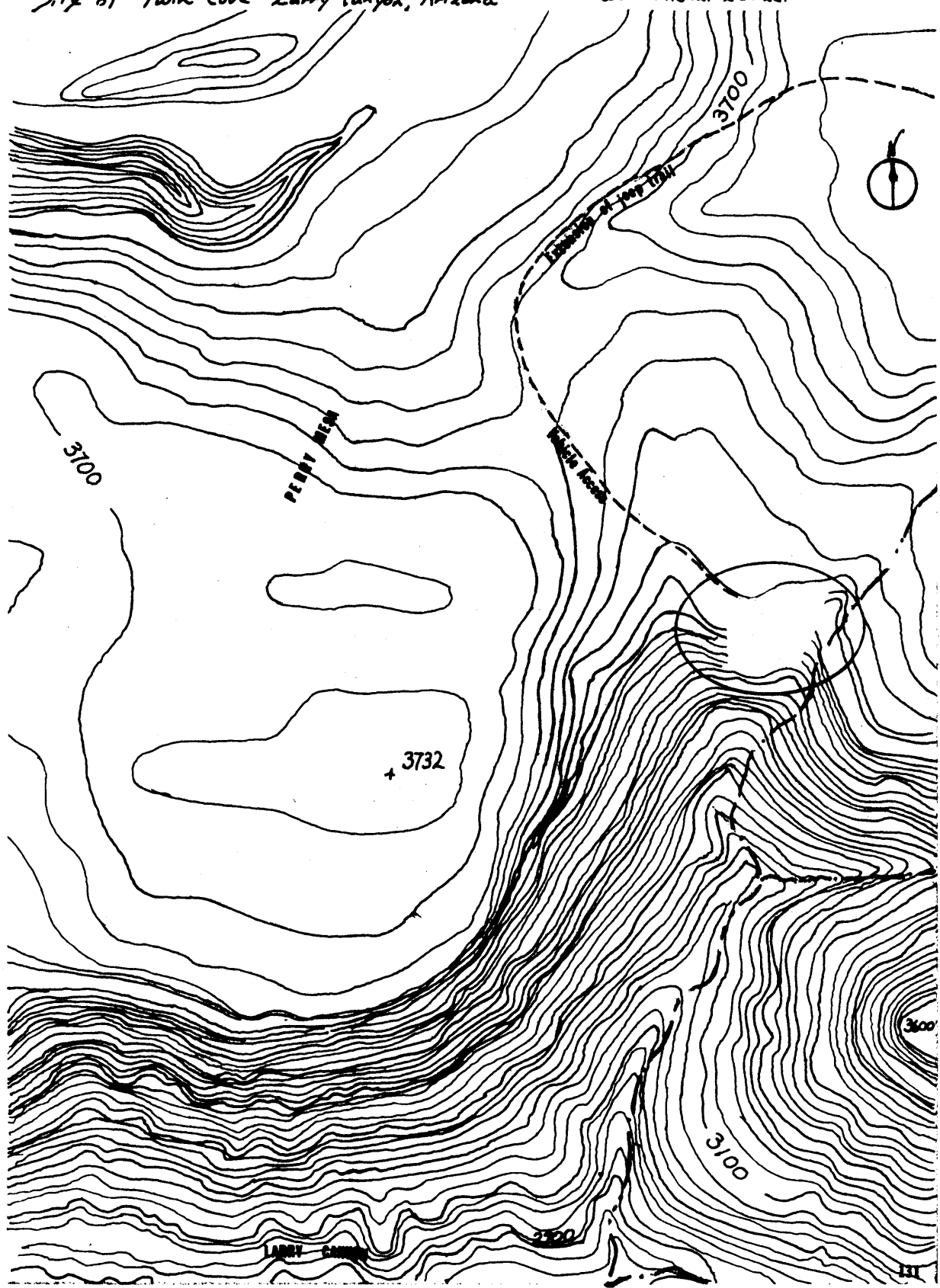

The site was then studied in terms of its natural drainage extensions (figure 132) as a means of predicting the most protected and secure sites from flooding and the ease of water transport, storage and supply.

Using the methods of building appropriate to this site and region as summarized in the precedent summary, the site plan was then constructed. The crucial design elements are:

- 1) Major building and access parallel to contours and oriented between south and southeast
- 2) Main streets average 10 feet in width, less than five percent slope; indicated on figure 134 by the dotted lines
- 3) Minor streets primarily are stairs averaging five feet in width with side entrances and labyrinthian private entry paths
- 4) High humidity vegetable and grain greenhouses constructed primarily of reinforced fiberglass panels and earth, terraced adjacent to Cove Creek (figure 135)

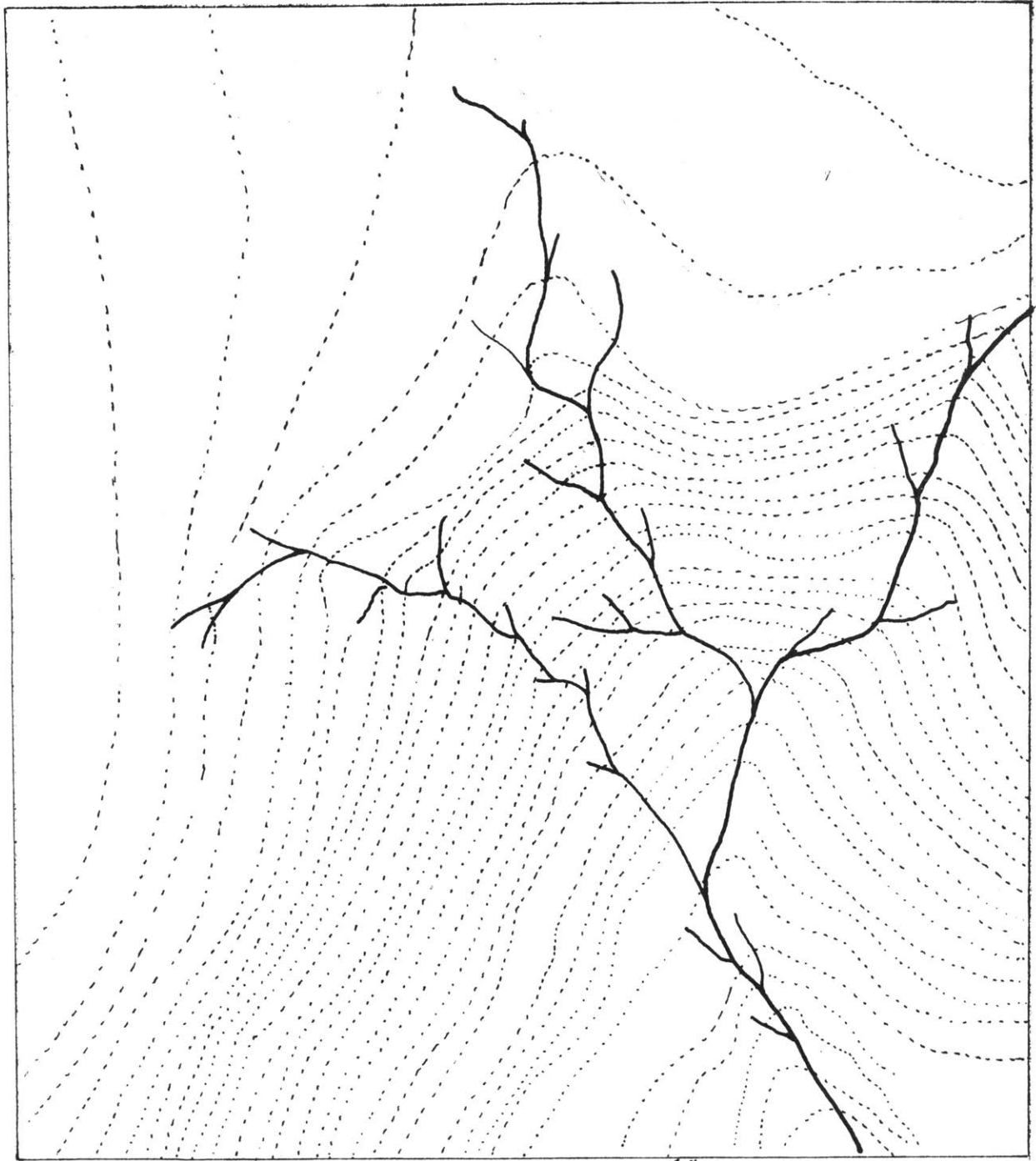

Extensions of natural drainage

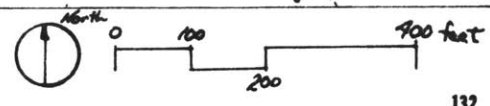

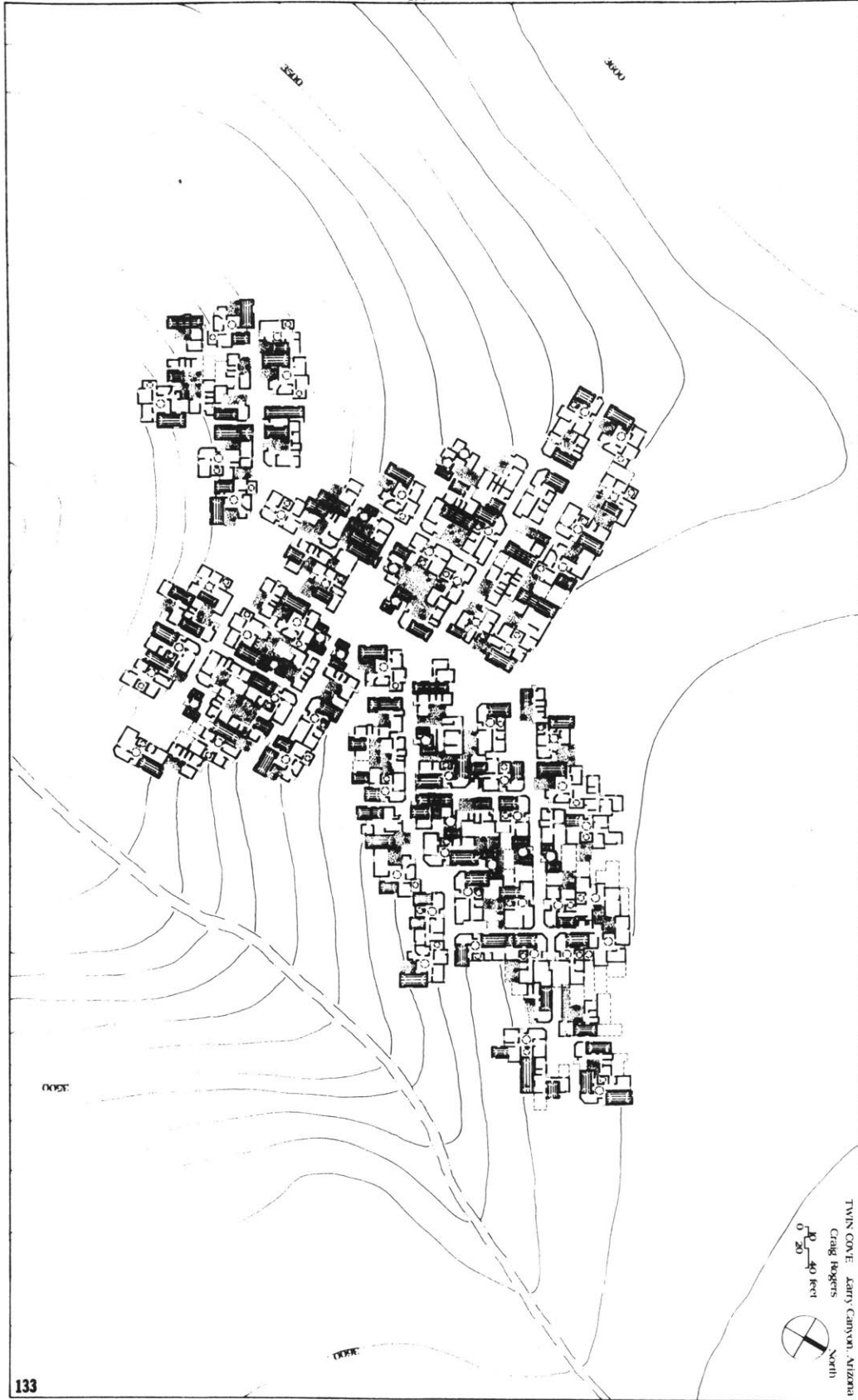

TWIN COVE, ASHLY CANYON, ARIZONA
Craig Rogers
0 20 40 feet

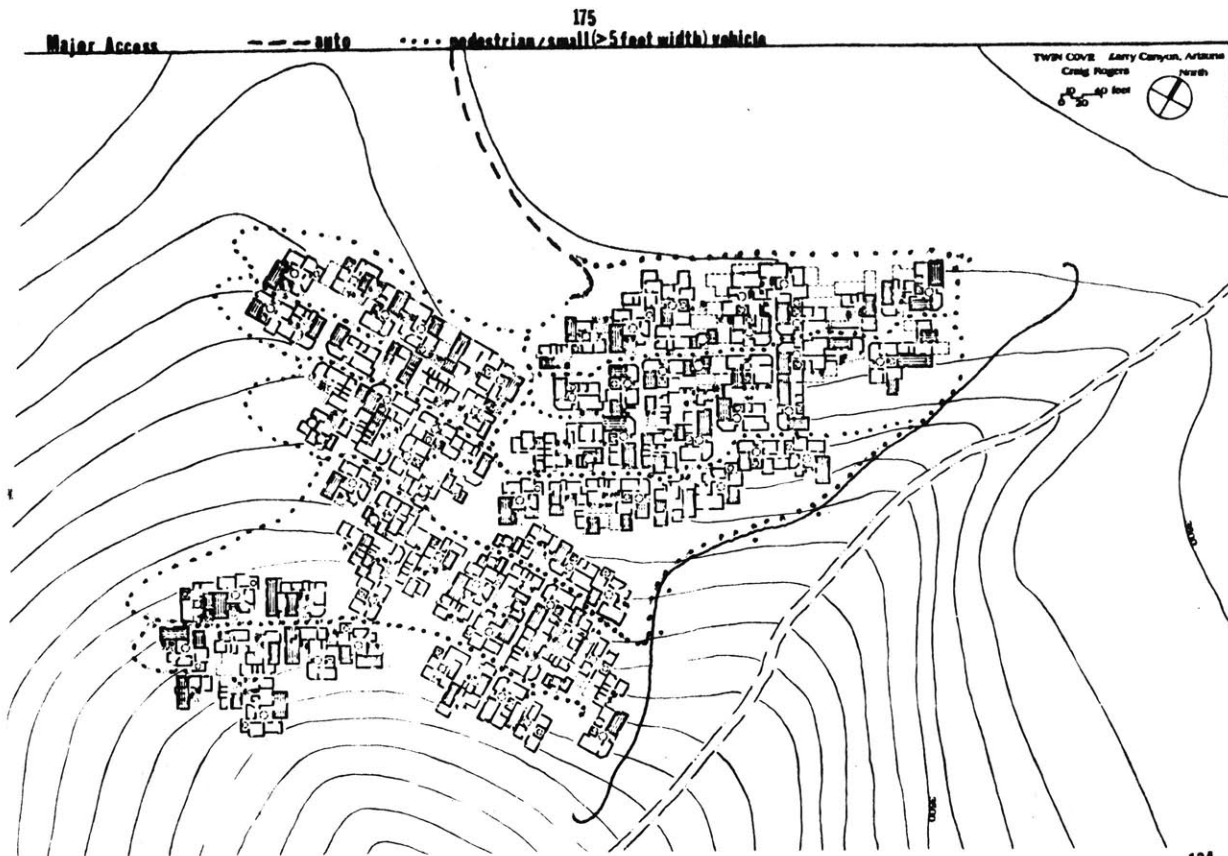

- 5) A wall is constructed partially paralleling the creek to provide additional protection for potentially large floodwaters
- 6) The highest ground provides central access and is the landscape intersection of the south and southeast orientations
- 7) Intersections of direction, major and minor streets and the exterior edges provide the larger defined collective spaces. The central collective spaces are frequently bordered by arcades.
- 8) The primary building material is the rock and earth of the site

- 9) Fifteen separate dwelling plans with location specific variations are defined primarily by self-stable masonry walls of combined 2 feet, 4 feet, 8 feet, 16 feet and 24 foot edges
- 10) Domes and vaults provide the high spaces needed for comfort and ventilation and can be built entirely of masonry. The domes usually located the wind catcher for controllable ventilation near their peak and a fountain or waterfall near their base
- 11) Flat roofs are constructed with moveable insulating panels sealed water heat transfer ponds
- 12) Open courts are frequently adjacent to one another and become central especially in the interior of the settlement

Figure 135 identifies two sections of the plan which are illustrated at the scale of one inch equals eight feet. The numbers on the illustrations refer to:

- 1) Wind Catcher
- 2) Wind Outlet
- 3) Fountain
- 4) Closeable Metal Screens
- 5) Moveable Insulation Panels

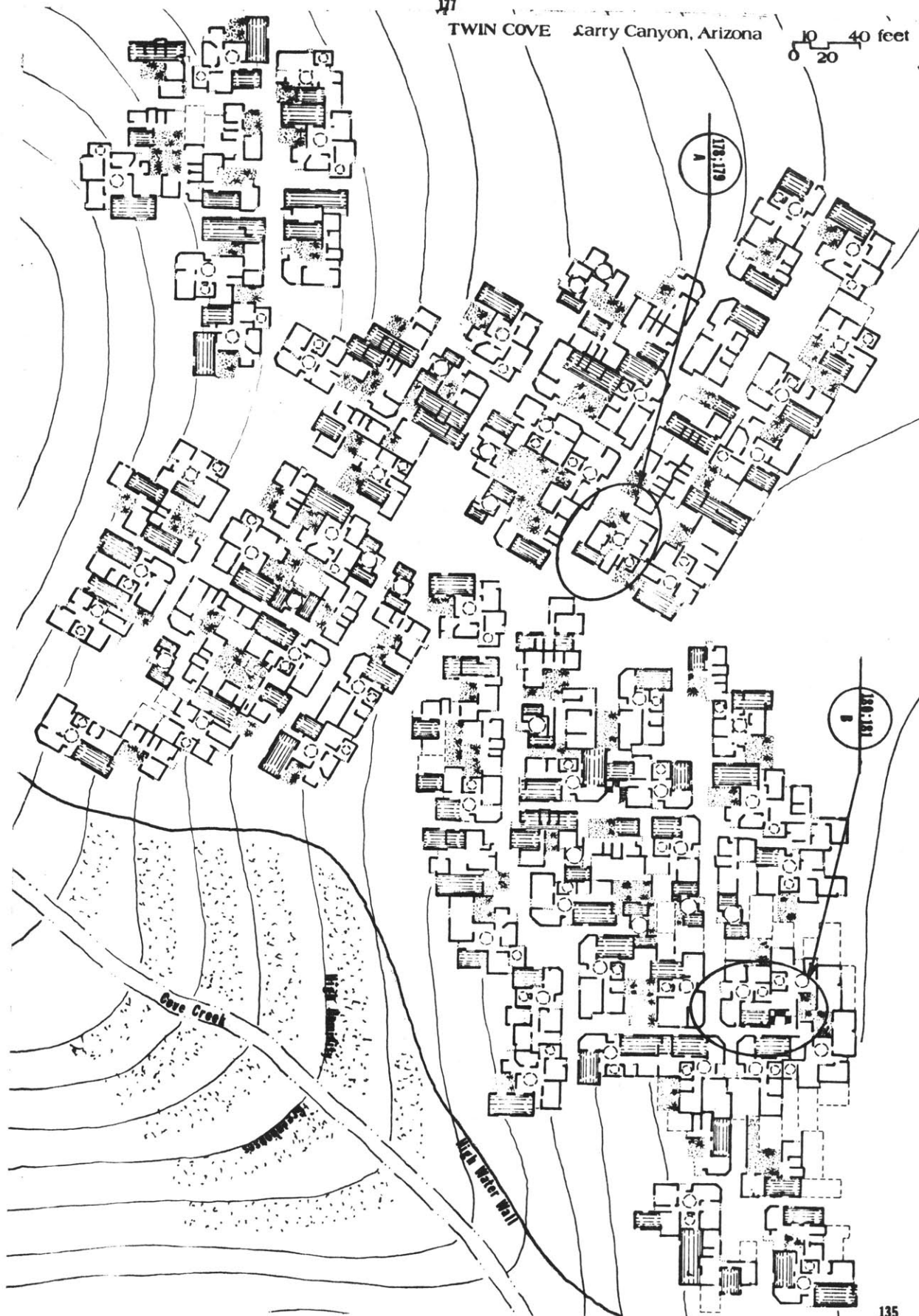

TWIN COVE



178 Central Plaza Building

0 2 4 8 feet

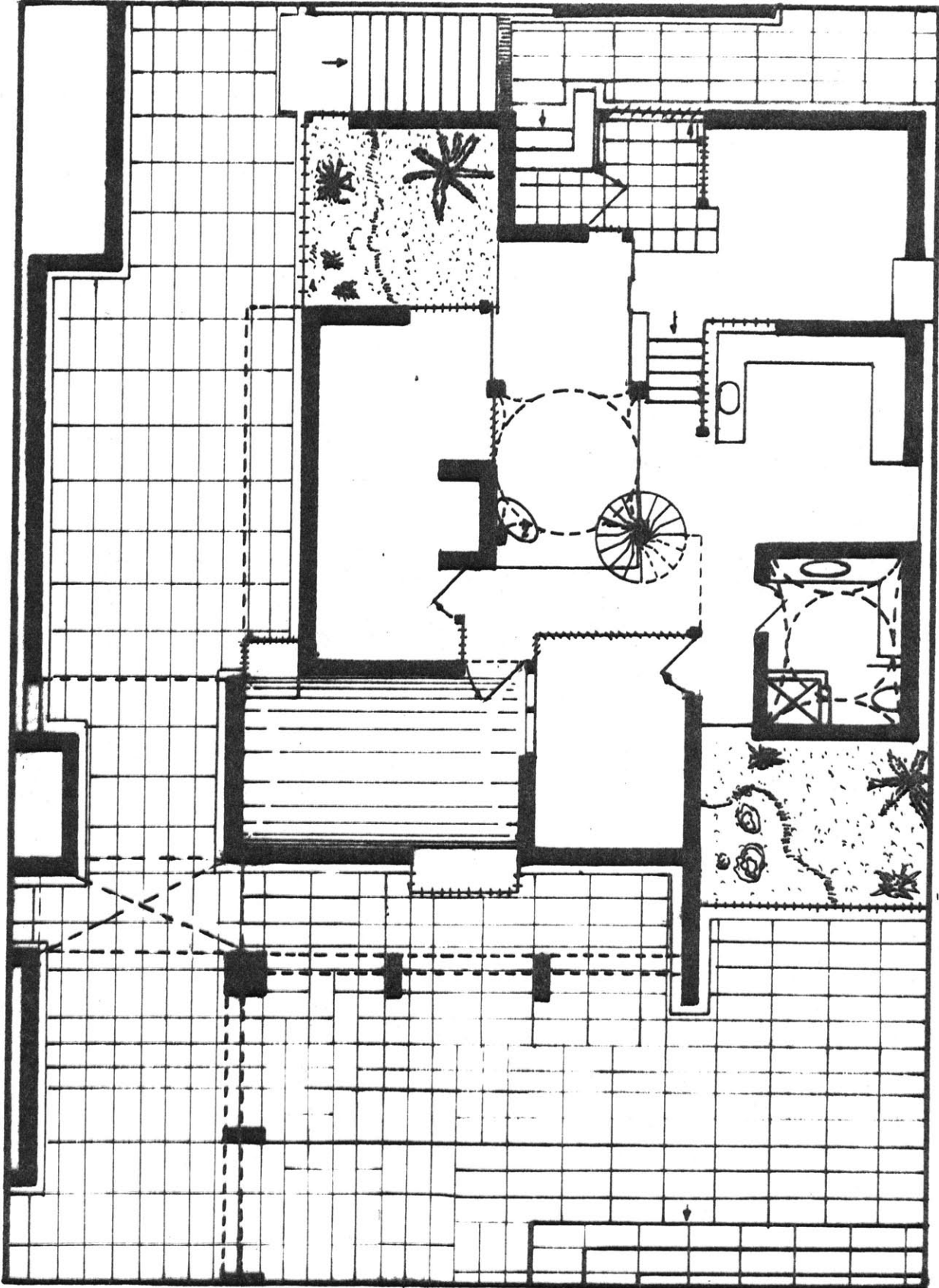

TWIN COVE



179 Sectional Axonometric - Central Plaza Dwelling

0 2 4 8 feet

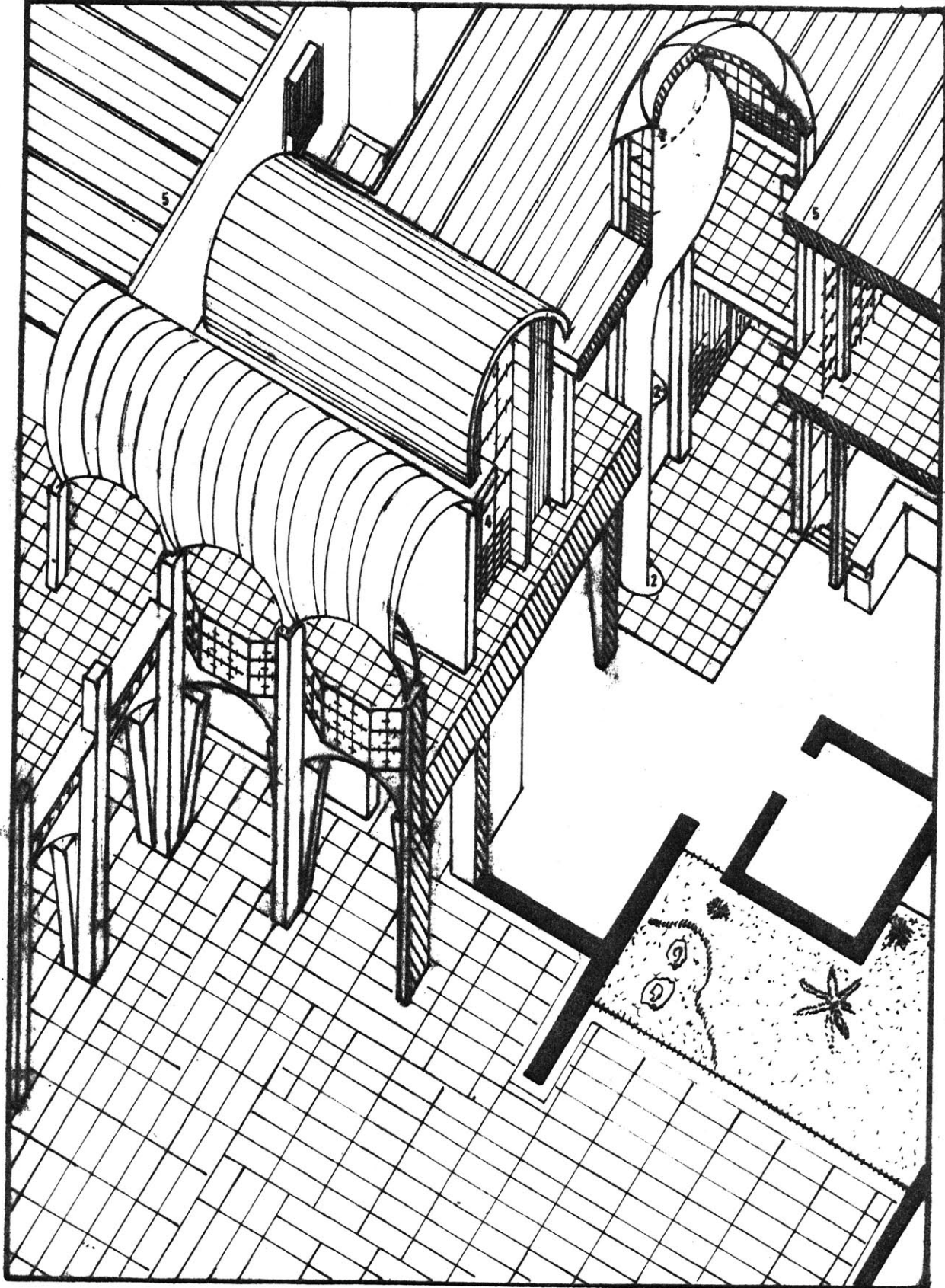

TWIN COVE

North

189
0 Plan - Interior Drawings

0 2 4 8 feet

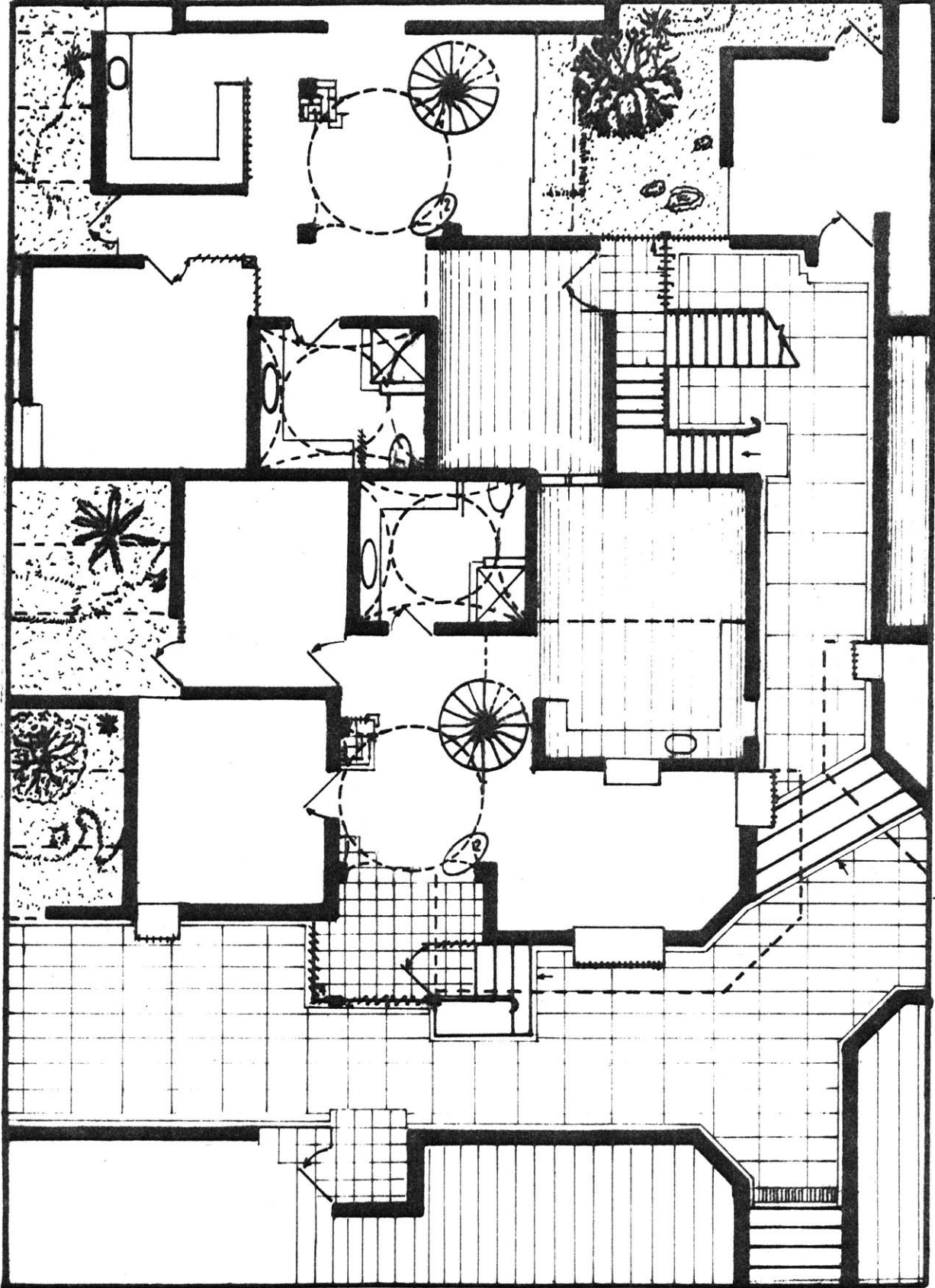

TWIN COVE



161
6

Axonomic - Interior Buildings

0 2 4 8 feet

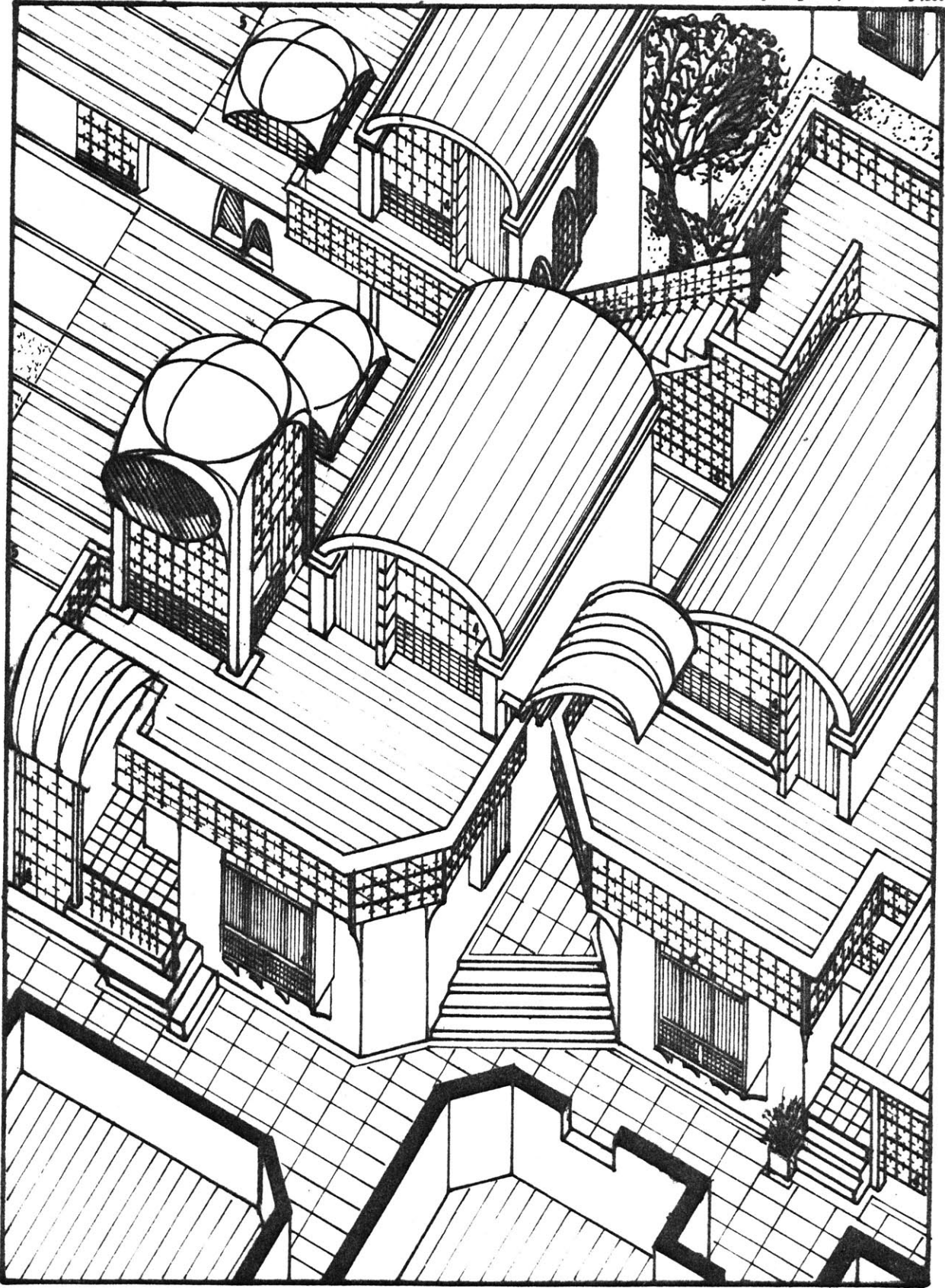

Bibliography

DESERTS

1. Allan, Leslie; Promised Lands - Subdivisions in Deserts and Mountains, Inform Inc., 1976
2. Amiran, David; Coastal Deserts, Univ. of Arizona Press, 1973
3. Carter, George; Man and the Land, Holt, Rinehart and Winston, 1964
4. Donald, I.; "Engineering Properties of Soils in Arid and Semi-Arid Environments" in Proceedings of the Symposium on Soils and Earth Structures in Arid Climates; Adelaide, Australia, 1970, Simmons LTD. 1971
5. Dregne, H.; Soils of Arid Regions, Elsevier Scientific Publishing Co., 1976
6. Hodge, Carle; Aridity and Man, American Association for the Advancement of Science, 1963
7. Hodge, Carle, editor; Urbanization in Arid Lands, Symposium, Dec. 26,27 1970, Icaalsals pub. no. 75-1, 1974
8. Kelso, Maurice; Water Supplies and Economic Growth in an Arid Environment, Univ. of Arizona Press, 1973
9. McGinnies, William, editor; Deserts of the World, Univ. of Arizona Press, 1968
10. McGinnies, William, editor; Food, Fiber and the Arid Lands, Univ. of Arizona Press, 1971
11. Walton, Kenneth; The Arid Zones, Aldine Publishing Co., 1969

ARIZONA

1. 'Arizona Highways', Dec. 1977, May 1975, Aug. 1975, May 1976

2. Boyle, Bernard; Materials in the Architecture of Arizona,
College of Architecture, Arizona State Univ., 1976
3. Central Arizona Project, Environmental Impact Statement
Central Arizona Project, NTIS Technical Report
4. Cross, Jack, editor; Arizona, Its People and Resources ,
Univ. of Arizona Press, 1960
5. Gummerman, George, et.al.; "The Hydrology of Prehistoric
Farming Systems in a Central Arizona Ecotone",
Lyndon Johnson Space Center, 1975
6. Parachek, Ralph; Desert Architecture, Darr of Arizona, 1967
7. Soleri, Paolo; The Bridge Between Matter and Spirit is
Matter Becoming Spirit, Anchor Press, 1973
8. Vroman, Adam; Photographer of the Southwest, 1916
9. Woddin, Ann; Home is the Desert, Collier Books, 1964

BULDING PROCESS

1. Center for Housing and Environmental Studies, Cornell Univ.,
New Building Block, Cornell Univ., 1968
2. McHenry, Paul; Adobe: Build it Yourself, Univ. of Arizona
Press, 1973
3. Paduart, A.; Shell Roof Analysis, CR Books Ltd., 1966
4. Prestressed Concrete Institute; Architectural Precast
Concrete, Prestressed Concrete Institute, 1973
5. Texas, Univ. of; "the Use of Earth Covered Buildings",
Proceedings of a conference held at Fort Worth,
Texas July 9-12, 1975

BUILT REFERENCES

1. Gatz, Konrad, ed.; Modern Architectural Detailing , Vol. 5,
Van Nostrand Reinhold Co., 1972

2. Fitch, James, ed.; Folk Architecture of the East Mediterranean, Columbia Univ. Press, 1966
3. Goldfinger, Myron; Villages in the Sun, Praeger Publishers, 1969
4. Gardi, Rene; Indigenous African Architecture, Van Nostrand Reinhold Co., 1973
5. Greenlaw, Jean-Pierre; The Coral Buildings of Suakin, Oriel Press, 1976
6. Kuitermann, Udo; New Directions in African Architecture, Studio Vista Ltd., 1969
7. MacNeish, R.S. et.al.; The Prehistory of the Tehuacan Valley, Vol. 1 : Environment and Subsistence, Univ. of Texas Press, 1967
8. Nijst, A., et.al.; Living on the Edge of the Sahara, Govt. Printing Office, the Hague, 1973
9. Oliver, Paul, ed.; Shelter in Africa, Praeger Pub., 1971
10. Roche, Manuelle; Le Mzab, B. Arthaud, France, 1970
11. Sabikhi, Ranjit; "Towns and Cities of Rajasthan", in 'Marg' magazine, Dec. 1964
12. Saini, Balwant Singh; Architecture in Tropical Australia, Lund Humpheries, 1970
13. Schoenauer, Norbert; Court-Garden House, McGill Univ. Press, Montreal, 1962

CLIMATE

1. CIB Steering Group S4, Colloquium; Teaching the Teachers on Building Climatology, Stockholm, 1972
2. Conway, Carle; The Joy of Soaring, Soaring Society of America, 1969
3. Eagleman, Joe; Visualization of Climate, D.C. Heath, 1976
4. National Oceanic and Atmospheric Administration, Climates of the United States, Water Information Ctr. Inc., 1974

5. Sellers, William; Arizona Climate, Univ. of Arizona Press, 1974

ECOLOGICAL PLANNING

1. Knowles, Ralph; Energy and Form, MIT Press, 1974
2. Knowles, Ralph; Owens Valley Study, Univ. of S. California, 1969
3. March, Lionel; The Architecture of Form, Cambridge Univ. Press, 1976
4. Mcfarland, Margaret; "Land-Use Allocation System", Toledo-Lucas County Plan Commission, 1976
5. MIT Lab of Architecture and Planning; "Housing for the Pequannock Watershed", 1976
6. Olygay, Victor; Design With Climate, Princeton Univ. Press, 1963

ENERGY IN BUILDING DESIGN

1. Anderson, Bruce; the Solar Home Book, Cheshire Books, 1976
2. Argonne Labs, "Solar Energy Concentration", NTIS Technical Report
3. ASHRAE Handbook of Fundamentals, 1975
4. Caudill, William; A Bucket of Oil, Cahners Books, 1974
5. Danz, Ernst; Sun Protection, Fredrick Praeger Pub., 1967
6. Duffield, Chistopher; Geothermal Technoecosystems, Office of Arid Land Studies Univ. of Arizona, 1976
7. Earle, Alice; Sundials and Roses of Yesterday, MacMillan Co., 1902
8. Egan, David; Concepts in Thermal Comfort, Prentice-Hall, 1975
9. Harper, Peter; "Radical Technology", Undercurrents Ltd., 1976

10. Heeschen, Conrad; "Modelling the effects of alternatives in natural energy systems in a small agriculturally community", M. Architecture Thesis MIT, June 1977
11. Meinel, Aden; Applied Solar Energy: An Introduction, Addison-Wesley Pub., 1977
12. Steadman, Philip; Energy, Environment and Building, Cambridge Univ. Press, 1975
13. Stromberg, R.; "Passive Solar Building - A Compilation of Data and Results", Sandia Labs, Albuquerque, 1977
14. Twardowski, M.; Soleil et architecture, Arkady, 1967

GEOLOGY

1. Corey, "Soil and Rock Strata to Trap, Filter and Store Water for Rural Domestic Use", NTIS Technical Report
2. Gilluly, James; Principles of Geology, WH Freeman & Co., 1959
3. Legget, Robert; Cities and Geology, McGraw Hill, 1973
4. Mitchell, Colin; Terrain Evaluation, Longman Group Ltd., 1973
5. Skinner, Brian; Physical Geology, John Wiley and Sons, 1977

LANDSCAPING

1. Clouston, Brian, ed.; Landscape, Design with Plants, Institute of Landscape Architects, 1977
2. Institution of Structural Engineers; Design recommendations for multi-storey and underground car parks, Institution of Structural Engineers, 1976
3. Kelly, Kathleen & Schnadelbach, R.; Landscaping the Saudi Arabian Desert, Delaney Press, 1976
4. McGinnies, William; "Guayule: A Rubber Shrub for Arid and Semi-Arid Regions", Office of Arid Land Studies Univ. of Arizona, 1975

illustrations

1. Monument Valley, NE Arizona, photo
2. Barrel cactus section
3. Diamant glider, photo
4. Wave diagram, after Conway, op.cit.
5. Dust particle diagram, Gilluly, op.cit.
- 6.& 7. Insolation on N,S,E & W walls, insolation data ASHRAE
8. Sundial
9. Insolation diagrams, Olygay, op.cit.
10. Soil diagram, Dregne, op.cit.
11. Box Canyon, Skinner,op.cit.
12. Pediment erosion diagram , Skinner ibid.
13. Geologic section of site, U.S.G.S., 1913 survey
14. Plant distribution on slopes, Gummerman, op.cit.
15. Basin and Range profile, McGinnies, Food, Fiber...,op.cit.
16. Saguaro and cholla cactus, photo
17. Rainfall distribution diagram
18. Havasu Creek, N. Arizona, photo
19. Drainage Basin runoff, Gummerman, op.cit.
20. Table of drainage basins, Gummerman, ibid.
21. Mountain slopes of central Arizona, photo
22. Comfort Chart for Phoenix, AZ., Olygay, op.cit.
23. Humidity for Central Arizona, Sellers, op.cit..
24. Water Balance diagrams, Eagleman, op.cit.
25. Check Dams, Hodge, Urbanization in ..., op.cit.
26. Archaeological data for region, Gummerman, op.cit.
27. Orientation diagram for ancient villages using data, ibid.
- 28.&29&30. Ancient Agricultural Systems, Gummerman, ibid.
31. Hohokam ancient canal system, Parachek, op,cit.
32. Water level change in Arizona, U.S.G.S. map
33. Aquifers in NE Arizona, Cross, op.cit.
34. Well in Algeria - Oliver, op.cit.; well in Morocco - Nijst, op.cit.
35. Underground irrigation and drainage, Kelly, op.cit.
36. Potable water collection, Corey, op.cit.
37. Ancient Negev farm plan, Hodge, Urbanization...,op.cit.
- 38.& 39. Runoff farming Negev, McGinnies, Food...,op.cit.
40. Nomogram, McGinnies, ibid.
41. Hydroponics, Harper, op.cit.
42. Abu Dhabi, Arizona Highways, May 1976
43. Geologic formations, Skinner, op.cit.
44. Geologic section, supra note 13
45. Interlocking of ocotillo and cactus along drainageways
46. Havasu canyon, N. Arizona, photo
47. Aerial photo of Agua Fria
48. Drainage patterns, Mitchell, op.cit.
49. Patterns of change, ibid.
50. Enclosing river bath, Havasu Creek N. Arizona
51. Temperature graph using temperatures from Sellers,op.cit.
52. Macedonia, "Use of Earth Covered Buildings", op.cit.
53. Landscape continuous over roofs, concrete cast over carved earth

54. Wind diagrams from data of Sellers, supra note 23
55. Parabolic cooker
56. Double-cusp water pumping, Meinel, op.cit.
57. Refrigeration, ibid.
58. Field of heliostats, New River, Arizona, photo
59. Hemispherical Bowl Collector, Meinel, supra note 56
60. Aerobic toilet, from literature of Enviroscope Inc., MA.
61. Pit Dwellings, Parachek, op.cit.
62. Heavyweight/lightweight construction, supra note 38
63. Ceiling of dwelling designed by Soleri, Flagstaff, AZ.
64. Wall Temperatures, Stromberg, op.cit.
65. Ventilated roofs
66. Sections of Atascadero dwelling, supra note 64
67. Model showing moveable insulating panels for roof ponds
68. Shell forces, supra note 52
69. Overhangs/Shading data from Egan, op.cit.
70. Interior fountains U.S. Embassy Delhi, supra note 38
71. Court pool convection from Saini, op.cit.
72. Arabian Wind Tower, supra note 35
73. House of Neb-Amun, supra note 9
74. Eddy diagrams from data of Saini, op.cit.
75. Arab screens, article on Hassan Fathy in Architecture
d' Ajourd 'him, Fevier 1978
76. Sunset over Monument Valley, NE Arizona
77. Matmata, Goldfinger, op.cit.
78. Section and plans of Montezuma's Castle
79. Montezuma's Castle, photo
80. Ain Leuh, Nijst, op. cit.
81. Ourika Valley, Goldfinger, op.cit.
82. Tizi-n-Tichka Pass, ibid.
83. Zaouia Ahansal, Nijst, op.cit.
84. Ait Abdarahim, ibid.
85. Metameur, Goldfinger, op.cit.
86. Section Ait Benhaddou, Morocco, Global Architecture#10
87. Ait Benhaddou, Goldfinger, op.cit.
88. Plan Ait Benhaddou, supra note 86
- 89.- 93 Jaisalmer, Kulbhushan Jain
94. Takrouna, Goldfinger, op.cit.
95. Acoma plan, Knowles, Energy and Form, op.cit.
96. Acoma mission court
97. Walpi pueblo
98. Mzab Valley plan, Oliver, op.cit.
- 99-101 Mzab, ibid.
- 102,103 Mzab, Roche, op.cit.
104. Pueblo Bonito, supra note 95 and 61
105. Arcosanti from south rim of canyon
106. Arcosanti design as of 1977
107. Arcosanti, dwellings surrounding ceramics apse
108. Doubletree workshop, Scottsdale, AZ.
109. Ksar alley, Morocco, Nijst, op.cit.
- 110.- 115 ksars, ibid.

116. Tinerhir, Goldfinger, op.cit.
- 117-121. Morocco, Nijst, op.cit.
122. Casablanca apartments, Kuitertmann, op. cit.
123. Plan and section of Casablanca apts. Saini, op.cit.
124. Typical medina townhouses, Nijst, op.cit.
125. Tennant Creek, McGinnies supra note 38
126. Continental Villas East, Scottsdale, Arizona
127. Bariz, plan, supra note 75
128. Bariz partial plan along alley, ibid.
129. Buildable Land, Map 20 page 67
130. U.S.G.S. Topographic map, Joes Hill, Arizona
131. Site of Twin Cove Larry Canyon, Arizona
132. Extensions of natural drainage, Larry Canyon
133. Twin Cove site plan
134. Major Access Twin Cove
135. Identified enlargement sections on site plan
136. Central Plaza Dwelling
137. Sectional Axonometric, Central Plaza Dwelling
138. Plan Interior Dwellings
139. Axonometric Interior Dwellings