

Units 1119

THE EDGE OBSERVED: *Island Landscape for a Marine Biology Facility*

by
GERALDINE A. STRINGER
Bachelor of Arts
Dunbarton College
Washington, D.C.
1971

SUBMITTED TO THE DEPARTMENT OF ARCHITECTURE
IN PARTIAL FULFILLMENT OF THE REQUIREMENTS OF THE DEGREE OF
MASTER OF ARCHITECTURE AT THE
MASSACHUSETTS INSTITUTE OF TECHNOLOGY

Signature of author
Geraldine A. Stringer
Department of Architecture
May 8, 1987

Certified by
Fernando Domeyko-Perez
Associate Professor of Architecture
Thesis Supervisor

Accepted by
Julian Beinart
Chairman
Departmental Committee for Graduate Students

© Geraldine A. Stringer 1987
The author hereby grants to M.I.T. permission to reproduce and to distribute publicly copies of this thesis document in whole or in part.

MASSACHUSETTS INSTITUTE
OF TECHNOLOGY

JUN 08 1987

LIBRARIES

Roten

ABSTRACT

THE EDGE OBSERVED: Island Landscape for a Marine Biology Facility

by Geraldine A. Stringer

Submitted to the Department of Architecture on May 8, 1987 in partial fulfillment of the requirements for the Degree of Master of Architecture

This thesis explores the concept of edges through observation and design. The intent of the observation/design is to understand and to illustrate possibilities for design that will enrich the experience of the built environment. For a building to start having reciprocal relationships with inside and outside territories, its structure and skin configurations must not be only one sided containments, but begin to engage in two-sided dialogues between interior and exterior spaces.

The possibility of overlap between individual parts, between the relationship of inside and outside and between the object and the ground it occupies is observed through Japanese vernacular buildings and their gardens and through the buildings and canals of Venice. Plans, sections and photo images are used as a way to become conscious of the characteristics that help make these places a total assemblage, with pieces in a coherent relationship to one another and to their site.

The design of a Marine Biology Facility on an island affords an opportunity to test out and explore the observation studies. The island exists in a landscape context that has clearly defined edge conditions. A harmony is sought that interprets the natural landscape and transforms it in such a way that there is a reciprocity and interaction with the built. Orientation, views and landscape considerations all provide generators for an architectural response that engages the built world and the natural world in a tensioned relationship that defines the edge zones.

Thesis Supervisor: Fernando Domeyko-Perez
Title: Associate Professor of Architecture

Dedicated to the memory of my father



A boundary is not that at which something stops but, as the Greeks recognized, the boundary is that from which something begins its presencing.

Heidegger

TABLE OF CONTENTS

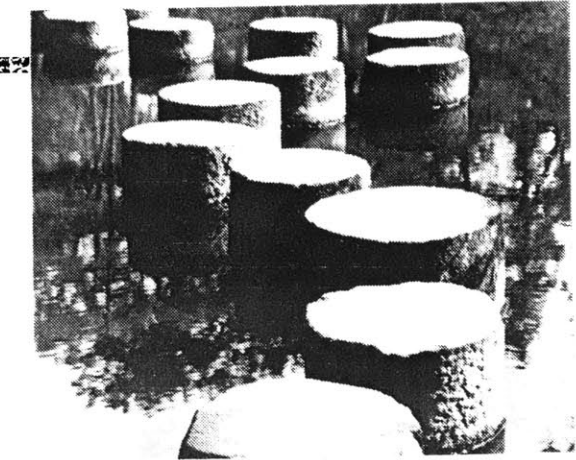

ABSTRACT

INTRODUCTION	1
OBSERVATION: Landscape Edge	5
OBSERVATION: Japanese Edge	13
OBSERVATION: Venice Edge	19
CLIMATE ISSUES	25
ISLAND/SITE	29
PROGRAM	39
DESIGN: Site	41
DESIGN: Building	49
BIBLIOGRAPHY	70

INTRODUCTION

This thesis has as a focus the observation and analysis of certain building edge and landscape conditions, and a second focus on the use of those observations as a design reference. Japanese vernacular buildings and gardens and the canals and buildings of Venice have been chosen for study because of their particular edge characteristics. The building edge to natural landscape relationship, the building edge to built landscape relationship, and the building edge to water relationship are the conditions that are of interest to this study.

Instead of designing simply an envelope to enclose and shape space, the building elements can be used in "their capacity as interfaces shared by, and therefore defining, the interaction between adjoining spaces." Seen as a two sided edge, the possibilities are there for the building enclosure to not only define the limits of space as well as creating distance for that space, but to set up occasions for the passage between and through the enclosure. "This dialectical capacity to integrate, as well as divide man's inhabited spaces...makes experiential the relationships between man's two archetypal worlds of being and belonging - inside and outside.

In Japanese buildings and gardens the conjunction of structure and nature was essential to the spatial expression of the building. There is a definite relationship to the landscape that is accomplished by the extension of architectural patterns from the inside to the outside, defining space through an ordered and continuous movement, progressing from the built interior out to the linking rhythms of rocks and plants in the landscape. The buildings and waterway canals of Venice will be observed for their clearly defined perimeter walls and for their wall to water relationships. The continuity of public movement, the definition of street/public edge and interior/private edge is precisely handled through material use. One knows that water, land and space are being held in check by a tension at the foundation-like wall system.

Because the program calls for a Marine Biology Facility on an island, the chosen reference edges are seen as informative to the design process. The goal is to acquire an attitude about edges and landscape, not a duplication of the observed conditions.

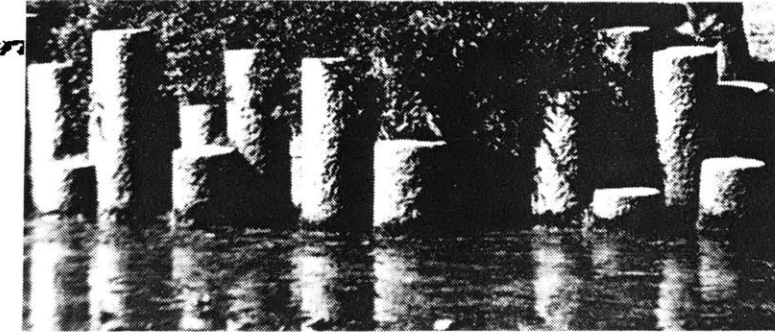



A further reason for choosing to study references that have a coherent relationship to their site is the hope that what is learned from them will have an influence on the design. As University of California, Berkeley design professor Marc Treib has written, "...industrial society tends to favor strong statements upon the face of the land whether by intention or benign lack of consideration." The design of the alienated building object, standing in contrast to its landscape setting, is reality in architecture today but one that it is hoped will be avoided in this design project. Many buildings seem to have only meagre transitional planting as a landscape/site planning approach, so it is hardly surprising that so many stand isolated as discreet entities without an organizing relationship either to neighboring buildings or to the landscape.

Architect/author Christopher Alexander has said that "...unless the building is oriented toward the outside, which surrounds it, as carefully and positively as toward its inside, the space around the building will be useless and blank - with the direct effect, in the long run, that the building will be socially isolated, because you have to cross a no-man's land to get to it." It is this dialectic of inside/outside edge and the concurrent issue of siting the building that I plan to address in this thesis.

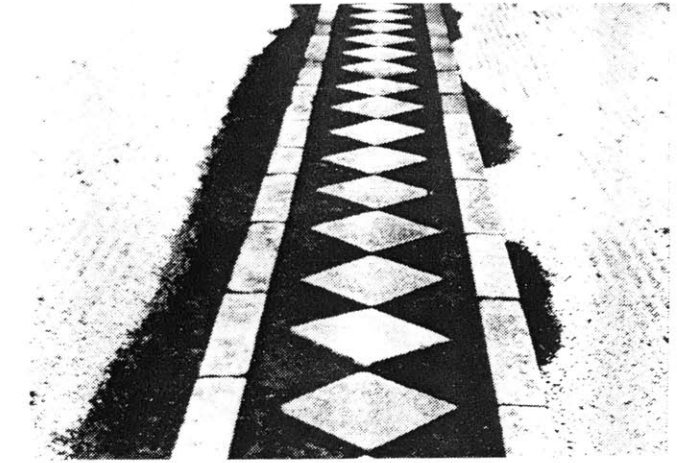

OBSERVATION: *Landscape Edge*



Study the examples of works left by the past masters and, considering the desires of the owner of the garden, you should create a work of your own by exercising your tasteful sense.

Tachibana Toshitsuna
Sakuteiki, ca. 1100

It has been said that landscape has as one of its functions the forming of a continuous ground upon which cities and other structures may appear. If the compositional elements of the natural context are understood, that is the character, structure and form, then it would follow that interactions with the landscape would be expressive of their locality and achieve a harmony with their surroundings.

"We must learn to exercise sensitivity toward the terrains we deal with and to make sure that we do not destroy their spirit." Tadahiko Higuchi believes that the spatial composition of terrain has great significance in the lives of the people who interact with a given site. It is the task of the designer then to consider the form, scale, materials and textures of the natural landscape and to interpret these sensitively in the development of built interventions. The designer ought to continually assess the impact

of the project on the site and throughout the process attempt to achieve a harmony between natural and built.

As theorist Norberg-Schulz states the problem, it is one of establishing a 'friendly' relationship with the site; the nature of the site must be understood so that it can be 'revealed and cultivated'. This does not mean, however, to leave things as they are found, but to transform and interpret a setting "into a place where human life may take place." Human activity gives form and order to spatial structures and allows man to reside, hopefully, at ease with his surroundings. If the built world has been regulated by the natural order of a place then those spaces will be unified and in harmony with the setting.

Natural 'Islands'

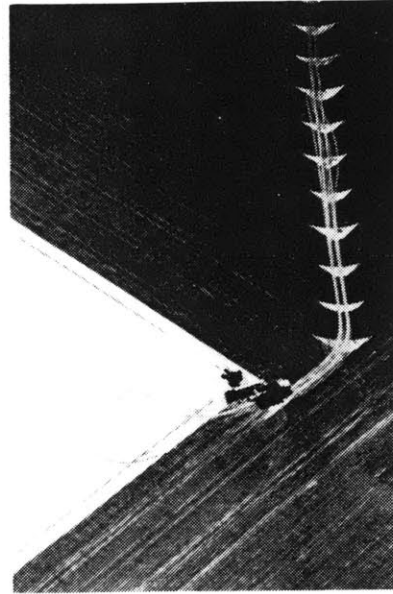
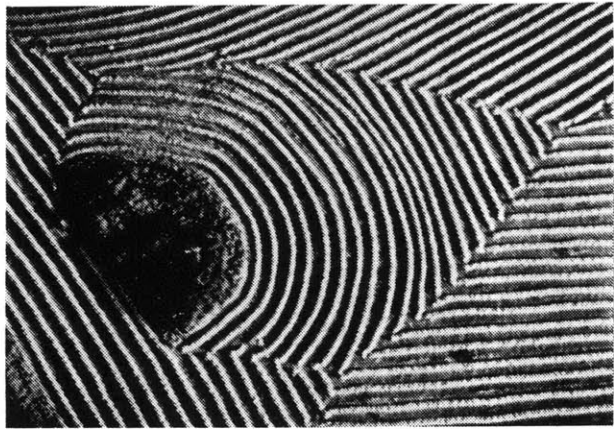

Path/Edge thru Landscape



The inside-outside relationship, a primary aspect of formal space, implies a degree of extension and enclosure. As stated previously, the extension of interior architectural patterns into the landscape outside gives the Japanese building a definite and precise relationship to the ground. There is a subtle movement from dark to light, from higher to lower and from built textures to natural textures. Architect Norman Carver submits that the Japanese insistence on natural finishes, color and textures helps to establish a continuity from architecture to nature. The action of architectural rhythms through an ordered movement from interior to exterior is an expression of space linking easily with the landscape.

Japanese landscape philosophy is enormously conscious of the importance of edges: how buildings meet the land, the setting up of zones of transition from outside to in, and a reciprocity and interaction between the built and natural form that seeks a harmony. A Japanese garden is a celebration of that which is elemental; it is an analysis of the world in which we live.



Extension into Landscape



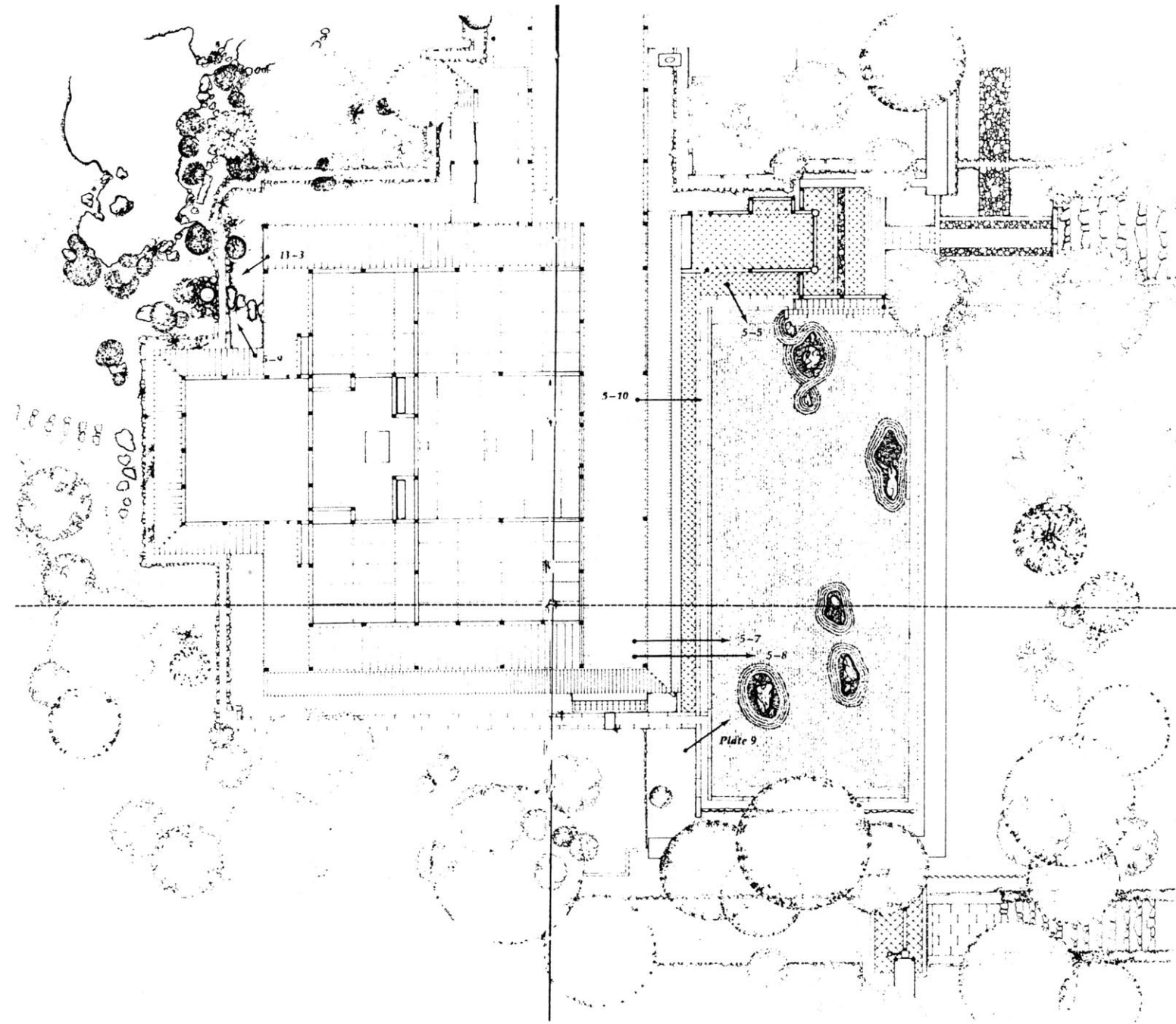

Ryoanji: Building/Garden Plan

Scale, m: 0 1 5



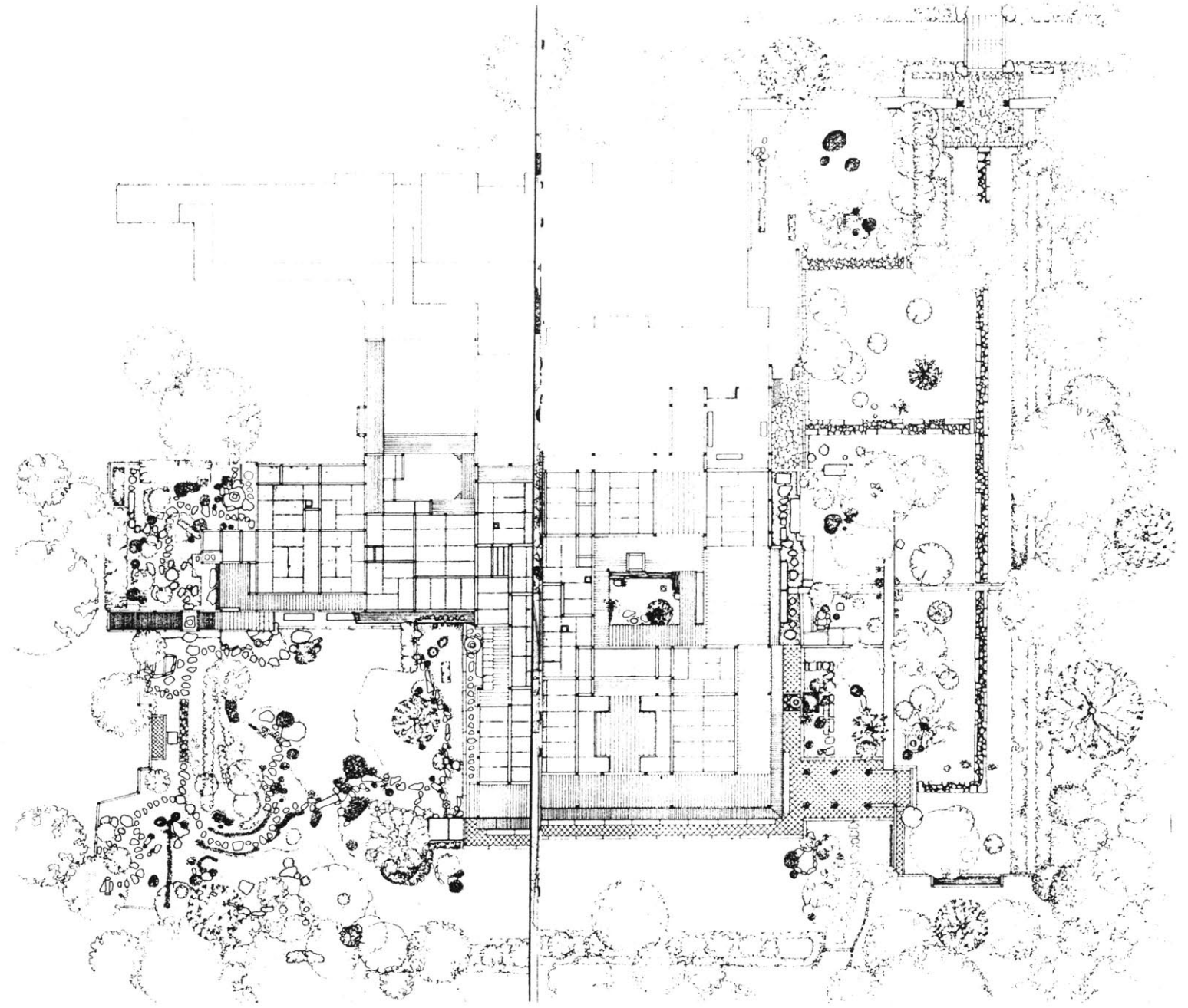

Kohoan: Building/Garden Plan

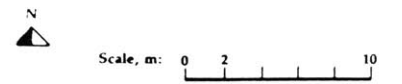



Scale, m: 2 10



Ginkakuji: Building/Garden Plan

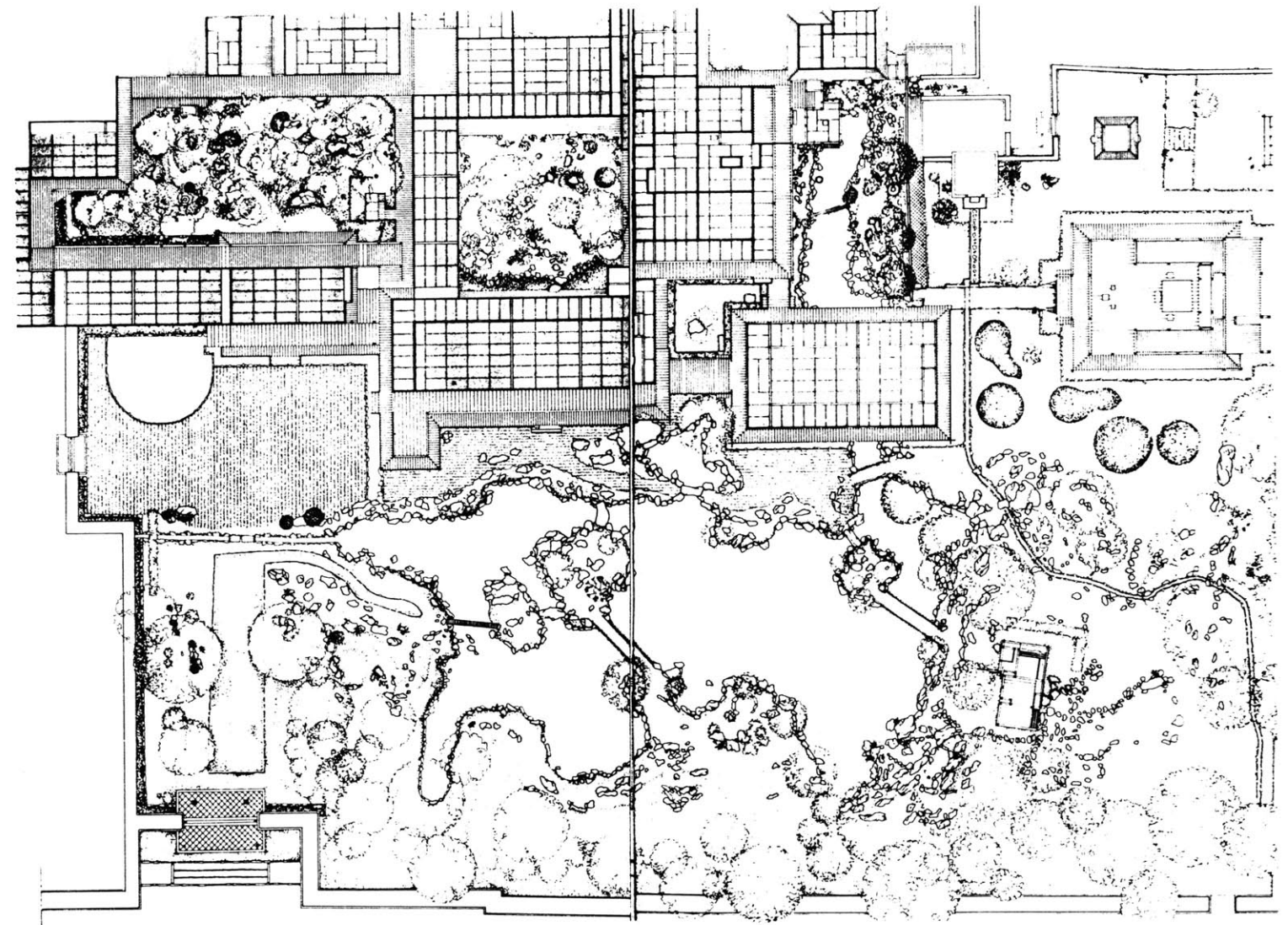

Sambo-in: Building/Garden Plan

Scale, m. 0 2 10



OBSERVATION: *Japanese Edge*

The examination of buildings from the Japanese vernacular is very compelling because these images are so rich in their articulation of a layering of structural elements. Structure defines formal spatial relationships through rhythmic progressions that continue out to the landscape. One observes a range of elaborations moving from interior to exterior developed by a series of planes and patterns that define space and create a sense of movement. Functional elements such as windows, grills, rails and fences reflect the primary structural pattern at a reduced scale. The additional architectural elements create an interplay that adds harmony to the space and helps to make the building edge a place of depth and interest.

Christopher Alexander writes that when properly designed, an edge can be a "realm between realms..." If the building walls are treated as spaces, zones that have some dimension and volume, then the connection between interior and exterior is increased and there is the possibility for movement from one side of the edge to the other, as well as the possibility for activity to take place within the realm of the edge itself.

The tensioned relationship of the defining elements can create a zone in which variety and contrast are allowed to happen and where the character of the building may be expressed. The interior and exterior may share characteristics at this in-between realm that produces an integration and the possibility for an exchange between territorial extremes - window and door openings, for instance. This edge boundary then, depends greatly on its formal articulation.

Japanese vernacular buildings, then, are clearly a resource for observing the thickening of the walls and the ways in which these three-dimensional transitions can help to connect the building to the world around it.



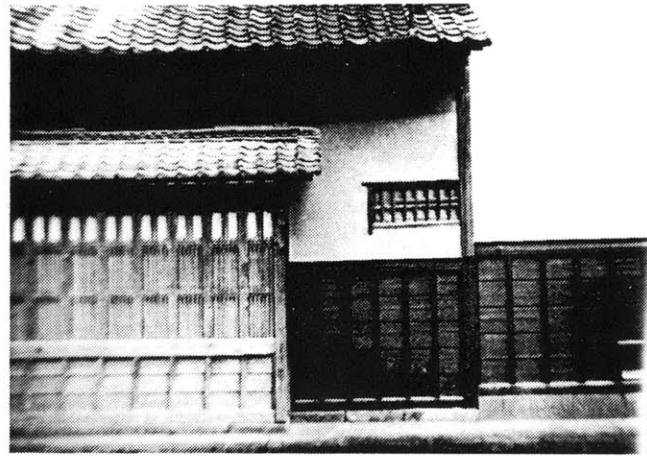

Roof Edge

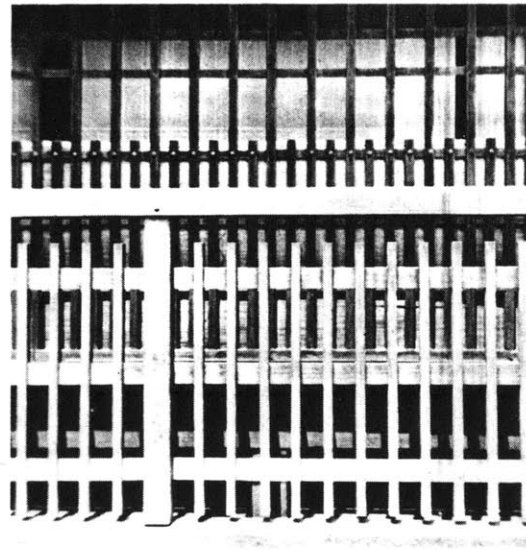

Screened Edges

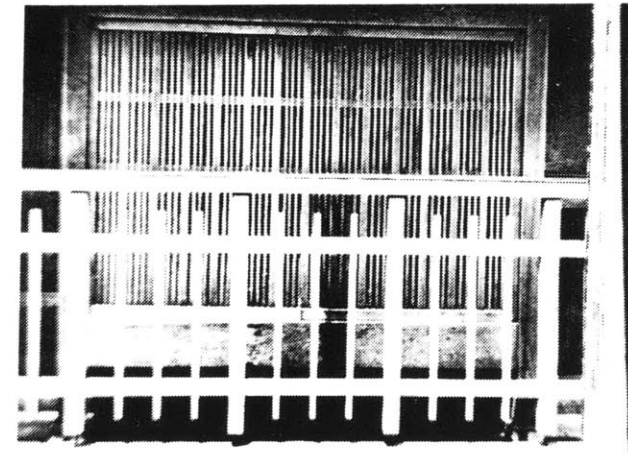
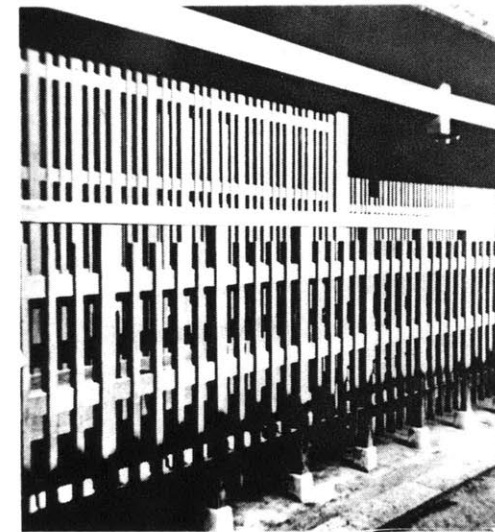
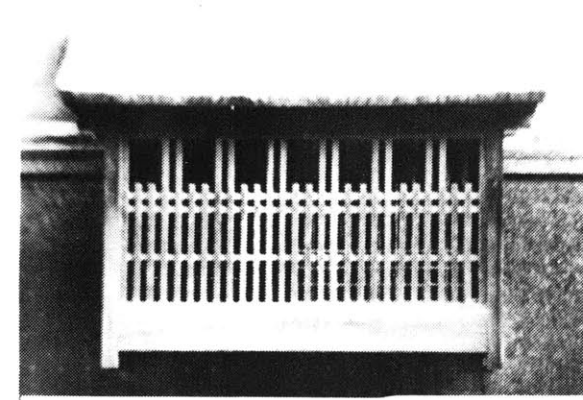

Building Edge

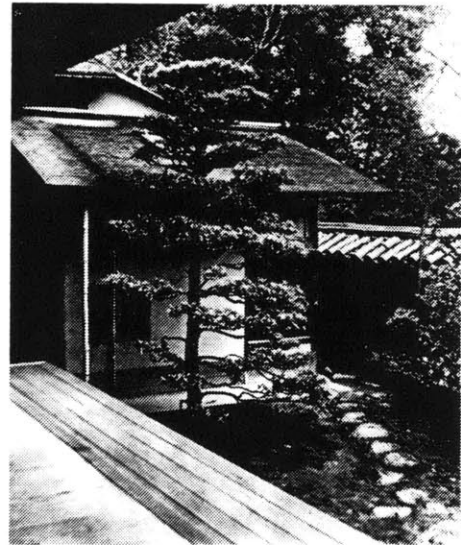
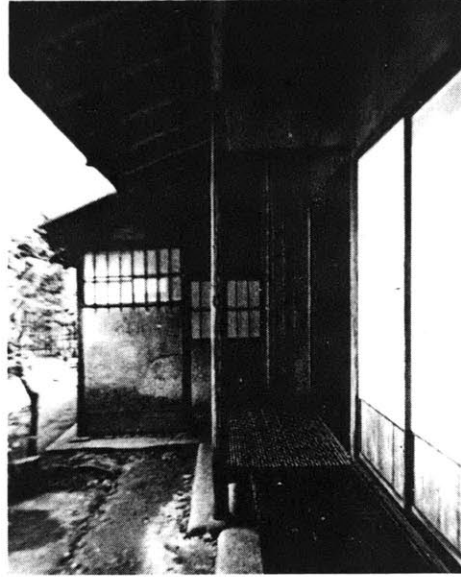
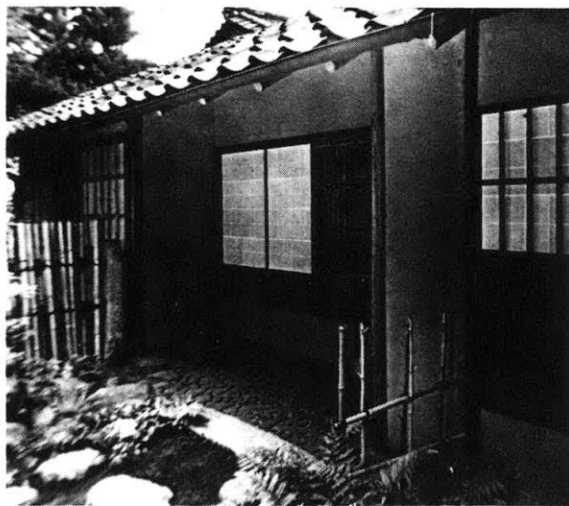
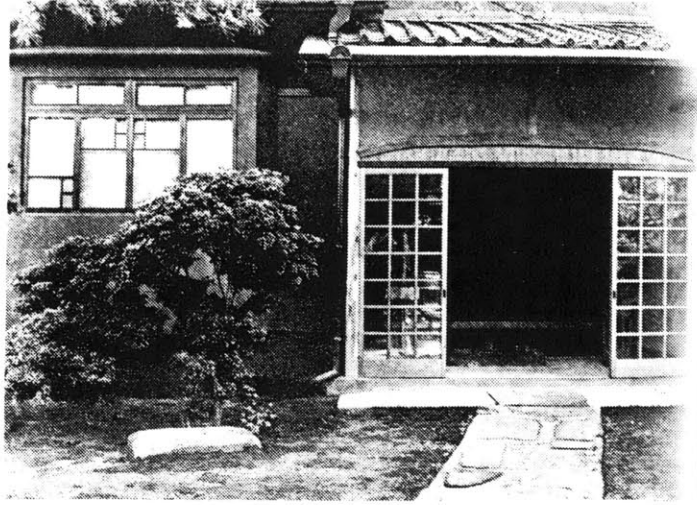

Window Grills/Screens

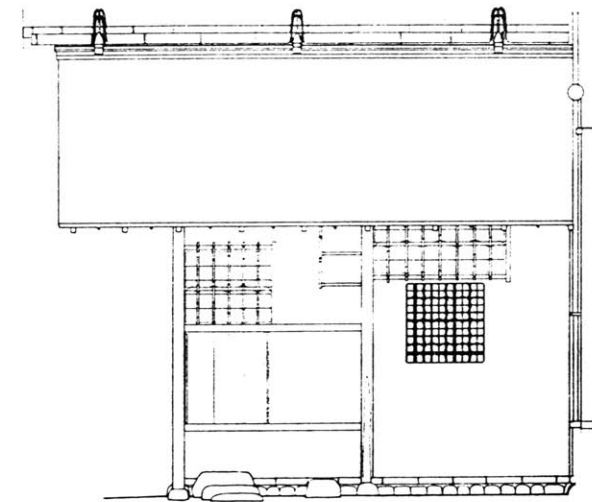
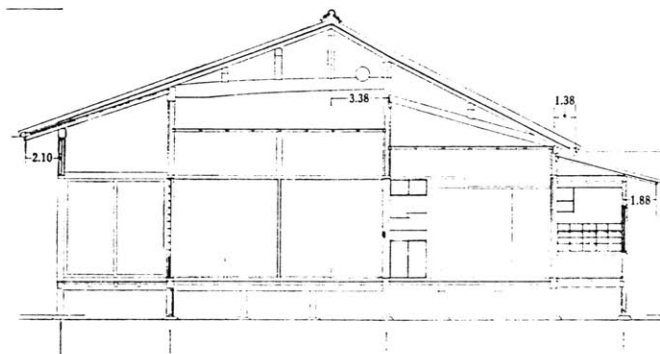
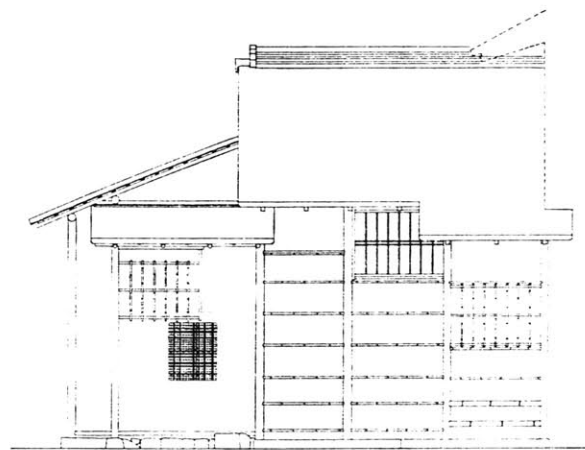
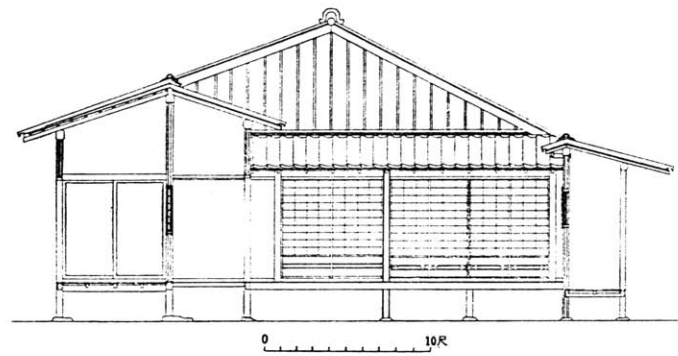
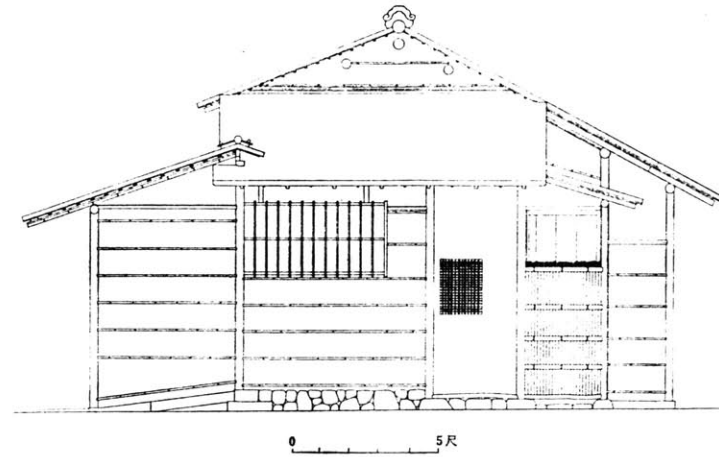
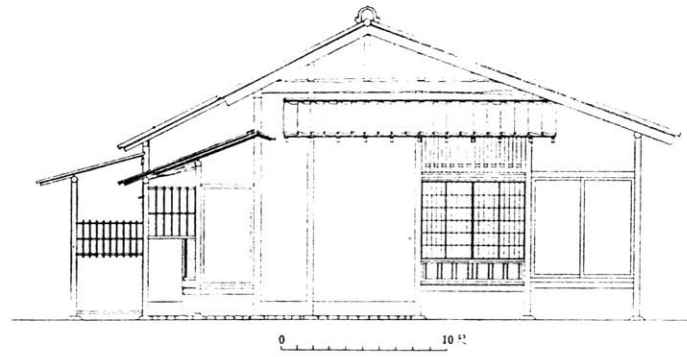

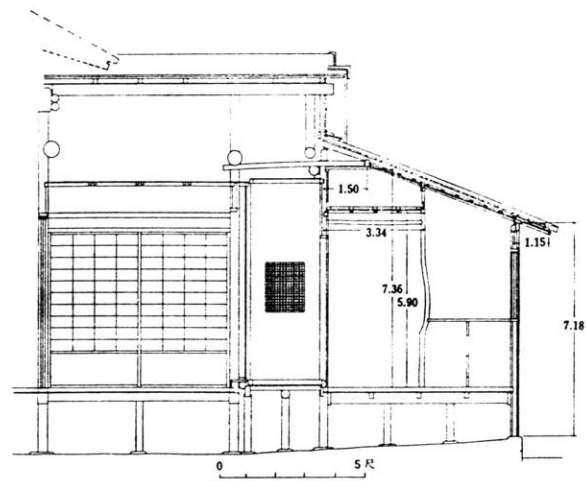
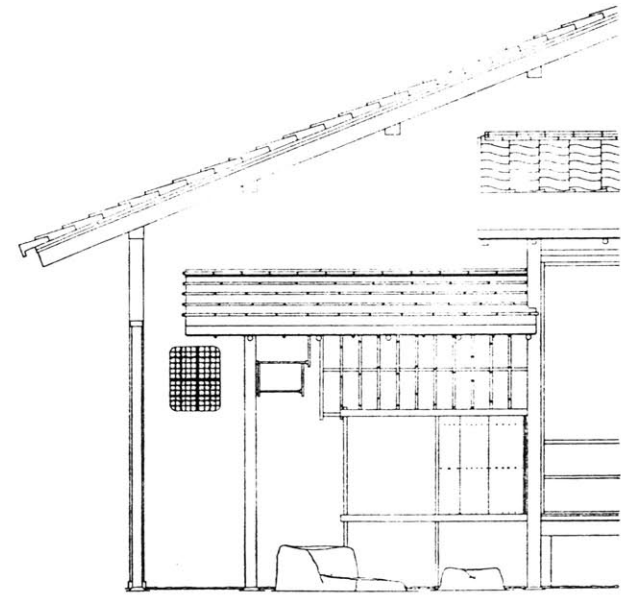
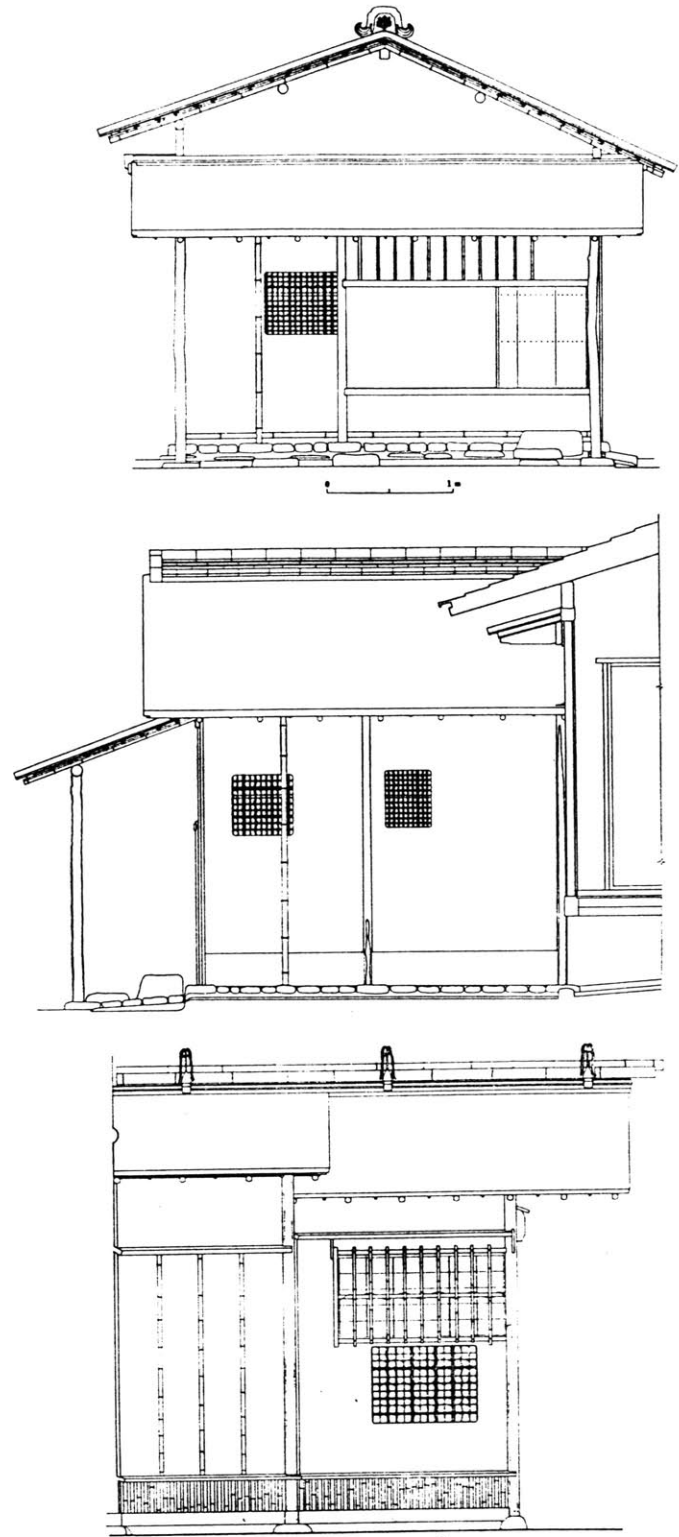

OBSERVATION: *Venice Edge*

If, as has been written, architecture comes into being when the perception of a total environment is understood and visible, then it seems natural to suppose that the man-made place has a direct relationship to the natural environment as a point of departure. The understanding of the natural context allows the genius-loci, the structure and character of the landscape, to come through and be concretized or expressed in the properties of built interventions. Norberg-Schulz states that "this is done by means of buildings which gather...the place and bring them close to man...To belong to a place means to have an existential foothold..."

I believe that Venice is a place in which a natural environment has localized a settlement and that architecture has been the means for emphasizing those qualities of place that were present. The natural context has been transformed through built form and organized space. Buildings define the edges of the island as well as establishing the direct figural relationship between sky, earth and water.

The character of the built environment is partially expressed by means of static masses of heavy

masonry walls. These walls do not suggest repose, however, as the constantly rippling water creates a contrast and increases the perception of space and light. Space is further enhanced by urban paths and squares that are created and contained by the walls of the surrounding buildings.

In Venice, one finds a continuity of public movement that is defined by the containing walls and as one moves through the spaces finds that the buildings separate to give vistas out to the watery landscape beyond. Movement is reinforced by the bridging of canals to facilitate continuity of the path.

The wall to water relation and the wall to interior space relation creates a tension that emphasizes the containing quality of the masonry wall systems. Inside and outside have distinct identities at the private building scale. Public buildings however, express a transition from exterior to interior through the use of loggias, collonades and recessed portals. In Venice, it is possible to feel both located and centered while experiencing an openness to the landscape beyond.



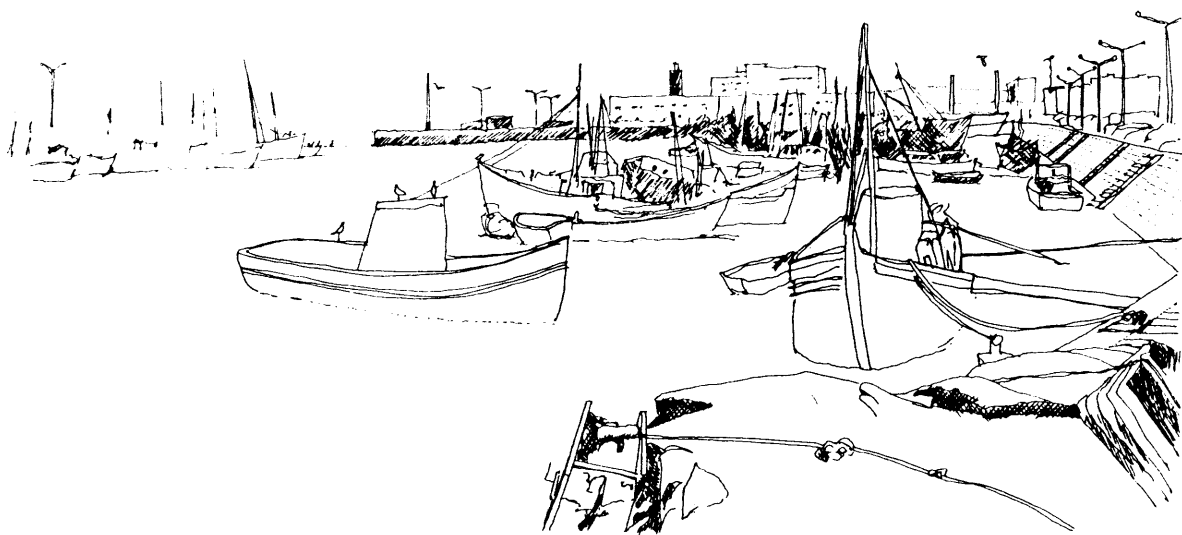

Harbor Edge: water and land in tension

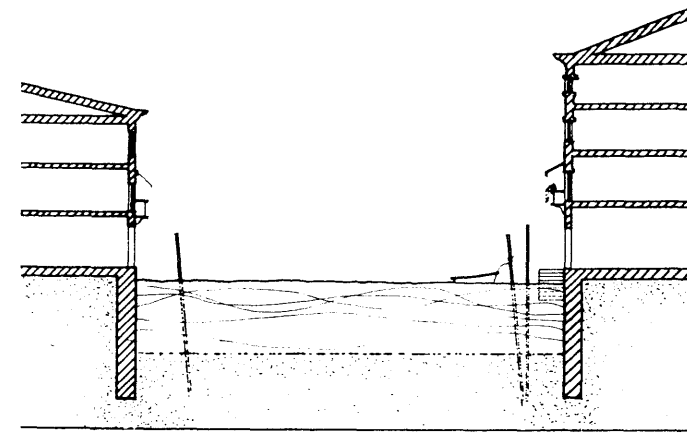

Water to Wall Relation

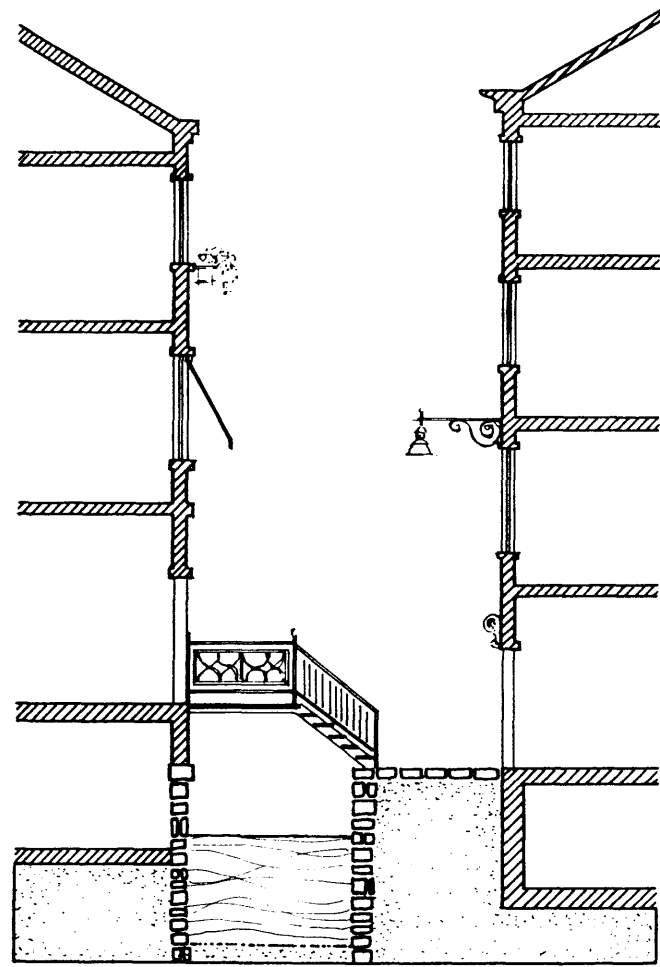

Retaining Walls: separation of water and land

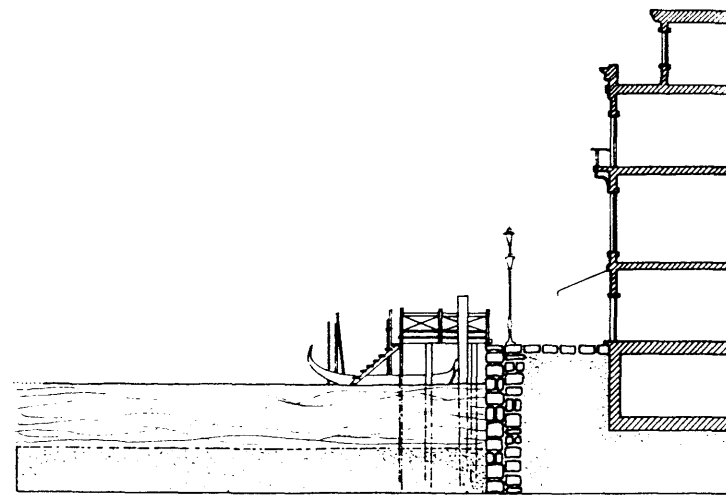

Built Landscape to Water Relation: moving out and over

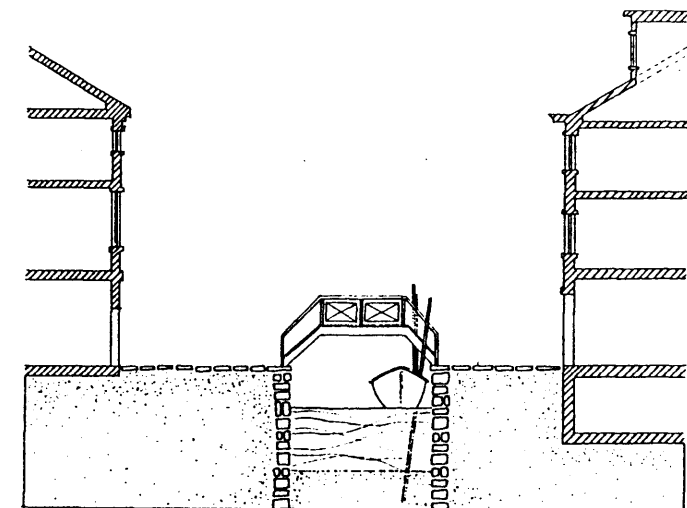

Continuity of Pedestrian Movement



*"Particularly significant are the centers suggested by the landscape itself, that is, those places where the world so to speak gathers itself. Natural centers obviously play a decisive role in determining the choice of a "here" for human settlement, and therefore ought to be given some attention."
Norberg-Schulz*



CLIMATE ISSUES

The site for this project is an island located in Lake Worth in West Palm Beach, Florida. The climate of coastal south Florida presents an environment in which sunshine averages 66% of the possible daylight hours and in which three-fourths of the year's temperatures fall within the 65% to 85% range, which produces a typical warm climate with small yearly temperature variations. The effects of temperature are magnified by humidity however. The average annual rainfall of 60 inches combines with ocean and undrained lowland evaporation to produce an unpleasantly high humidity during the majority of the year. Because of the effects of solar radiation, it is an appropriate design decision to utilize the natural moderating influences of shading and wind to produce environments that can come within the comfort range during the overheated months. Olgyay suggests that shading is needed 88% of the year, while wind is required 62% to reduce temperatures and humidity.

The majority of adverse solar loading occurs when the low angle sun from the east or west penetrates window openings and heats up a building's interior. The high mid-day sun causes only minor wall

exposure with the major radiation falling on horizontal surfaces, but positive roof insulation and use of light colored roofing material, if possible, minimizes this effect and makes the roof surface efficient in the reflection of radiation. Shading is an obvious solution to reduce the solar impact on east and west sides. Architectural solutions, wide roof overhangs and screening devices for instance, are advisable and may be enhanced by the careful use of vegetation. High canopy trees provide shade while allowing breezes to pass below, overly dense or low trees may prevent air movement and trap humidity.

The need to improve climate conditions in the Hot-Humid areas also dictates a usage of energy-consuming climate control systems for a significant part of the year. It is appropriate to reduce the over-all need for energy-consuming systems by improving the microclimatic conditions through solutions in architecture, site planning and landscape design. These solutions will help to reduce the impact of solar radiation as well as lessening the effects of high humidity.



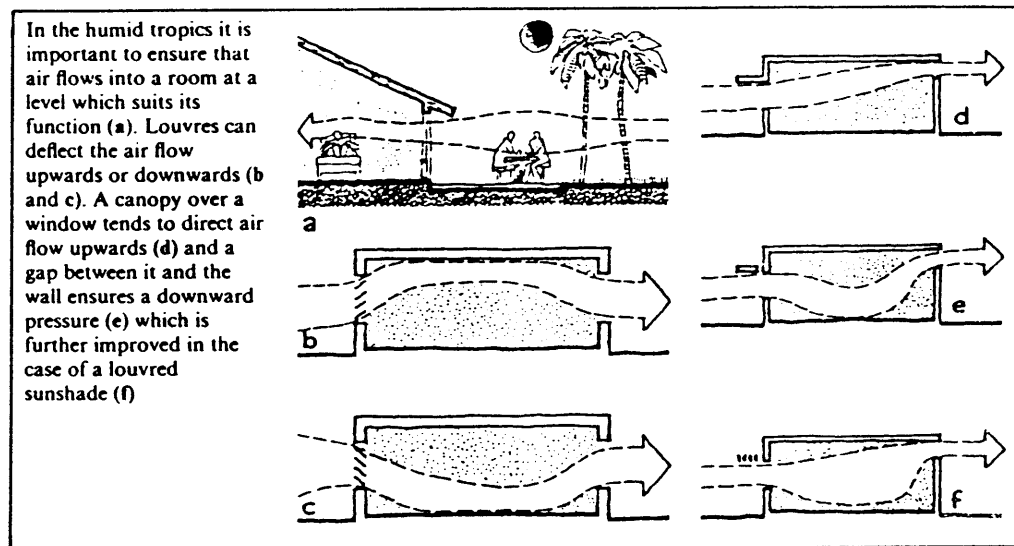
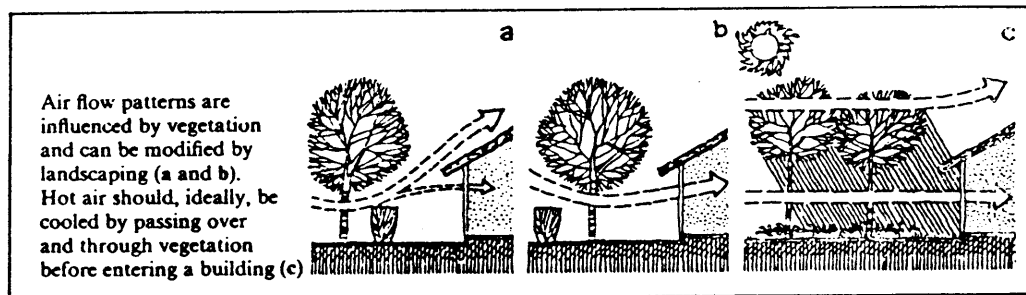
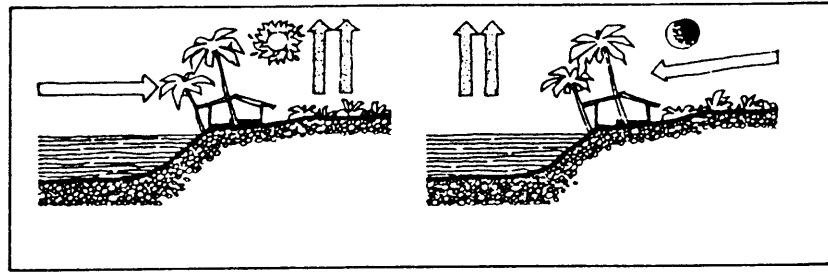



*Palm Beach Context: Climatic response thru architecture;
covered walkways, loggias, wide roof overhangs*

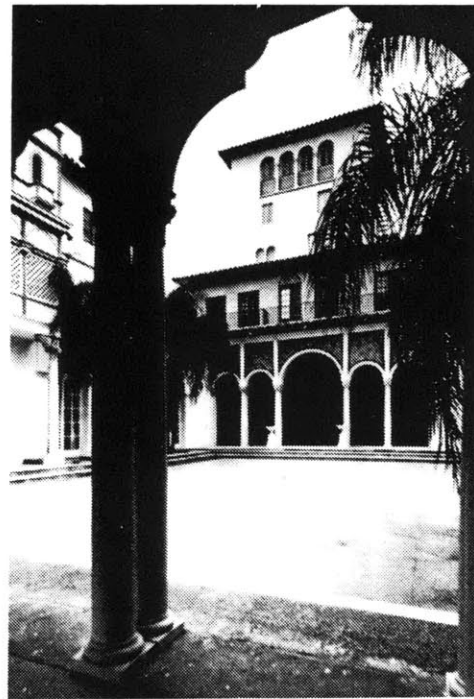

ISLAND / SITE

"...some unsuspected isle in far-off seas..."

Robert Browning

There is something appealing about an island. It beckons to us from across the water and there is often a sense of romance and escape associated with these bits of land because they are set apart from the rest of us geographically. They may take on 'sacred' qualities because they are perceived to be so removed from the 'profane' world of the mainland. Indeed, through history there have been cultures that have used islands for religious and ceremonial purposes, investing them with a meaning, that combined with their visual qualities, make the islands inevitable objects of attention. Philosopher Mircea Eliade suggests that such sacred places are not chosen by man, but are discovered by him through a process of revelation. The sacred place acts as a 'center' to orient man and as a place of identification in its capacity as a spatial structure.

Islands generally have a high degree of visibility because they are free-standing and set apart from the main body of land (providing, of course, that they are visible from the mainland). They may stand out in contrast to their background vistas and be

"endowed with prominence of spatial location." 1
The surrounding waters of an island gather its image and so reflect back the "height of the sky and the depth of the earth."

These waters generate a very particular kind of spatial configuration which must be seen as a distinctive natural place. The theorist Norberg-Schulz writes that "the island thus, is a place par excellence, appearing as a clearly defined figure." The edge of an island forms a precise definition which as Norberg-Schulz contends, functions as the primary structural elements for that landscape. These edges define both the surrounding water and the adjoining land.



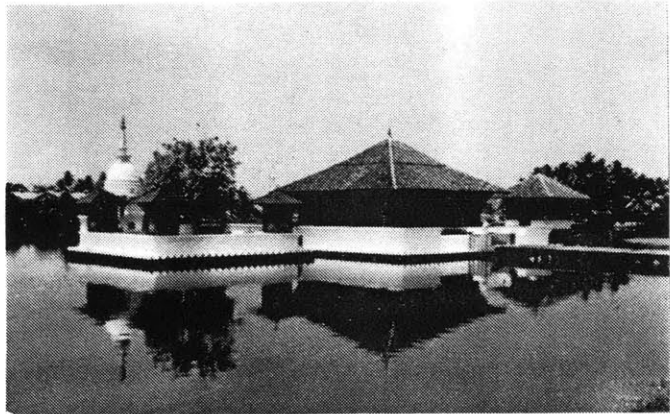

Geoffrey Bawa: Island site for Buddhist temple

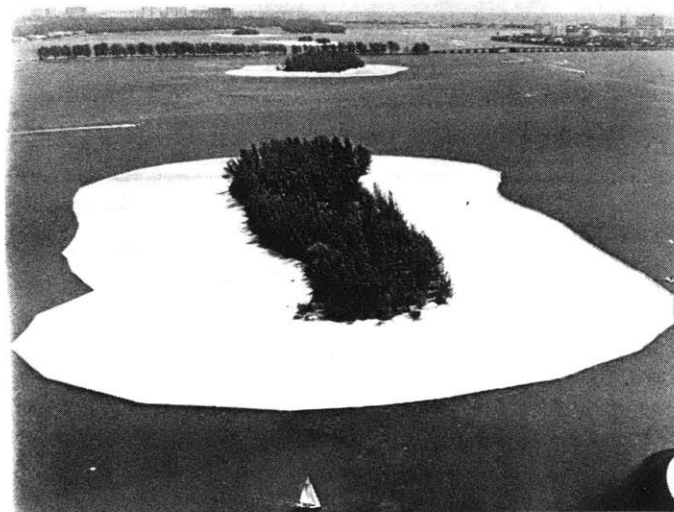

Christo: Surrounded Islands

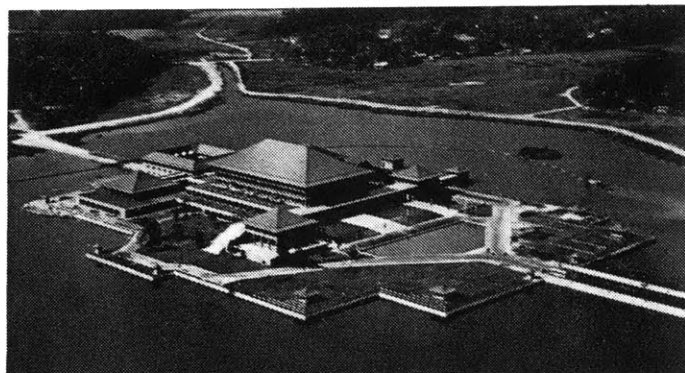

Geoffrey Bawa: Island site for Parliament buildings

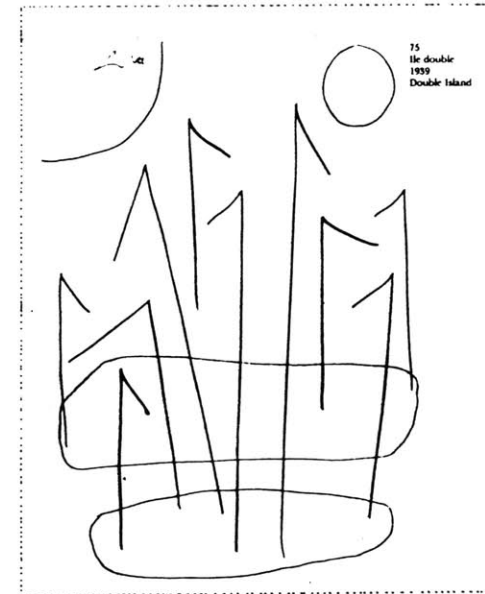

Klee: Double Island

If landscape can be said to have certain character and spatial structure, then the island site for this project is an element within the Focus-Center-Goal category of Japanese spatial/landscape researcher Tadahiko Higuchi's classification system. The island, which can be seen from the opposite shores, has qualities of visibility in short and middle distance views. Its 70 densely wooded acres, lying in Lake Worth at the apex of the ship channel and the tongue of the Atlantic, have a definite physical presence for those nearby on land or water.

The primary spatial definitions are given by the jungle-like, lush forest vegetation covering most of the land mass, and by the directional extension of the island's topography. The surface relief is characterized by two low hills that take up the dominant south-west to north-east movement of the landscape and continue it out and down to sandy stretches located at the outer edges of the thickly treed interior. The material substance of the surface is primarily textured by sand, but one only senses this at the water's edge where the beaches are visible and accessible. The surface relief of this island is less prominent than the spatial effect of the dense vegetation, which consists of nearly impenetrable stands of Australian pine, by a species of palm and by low tropical bushes.

Inlet Island, as it is known, was created in 1918 by the placement of spoil from the original excavation of the channel between Lake Worth and the ocean.

By 1923 it consisted of 47 acres and it continued to grow for a number of years as it served as a spoil site for deepening and enlarging the Port of Palm Beach's turning basin and entrance channel as well as for dredging the Intracoastal Waterway. The only formal inhabitants of the island are the officers assigned to the existing Coast Guard station which was built in 1936 on the southeastern edge of the island. Occupying 3.5 acres, it consists of a barracks, boathouse and docks. The original buildings are still standing, their exteriors looking much as they did 50 years ago.

The mainland to the west is of an industrial character, with the Port of Palm Beach, Florida Power and Light, sugar and molasses storage tanks and numerous shipping berths and boating marinas located along the water's edge. Singer Island to the north-east is primarily residential, with a mix of low single family houses and a strip of high rise condominium construction on the ocean edge. Private boat docks and marinas line the Lake's edge. Palm Beach Island on this northern end is residential, with many of the houses built in a predominantly Mediterranean vernacular style. Many of the homes also have small boat docks extending into the Lake.

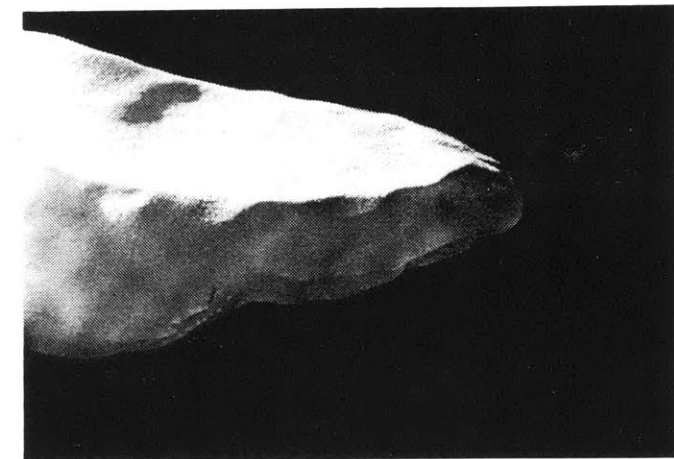

Islands

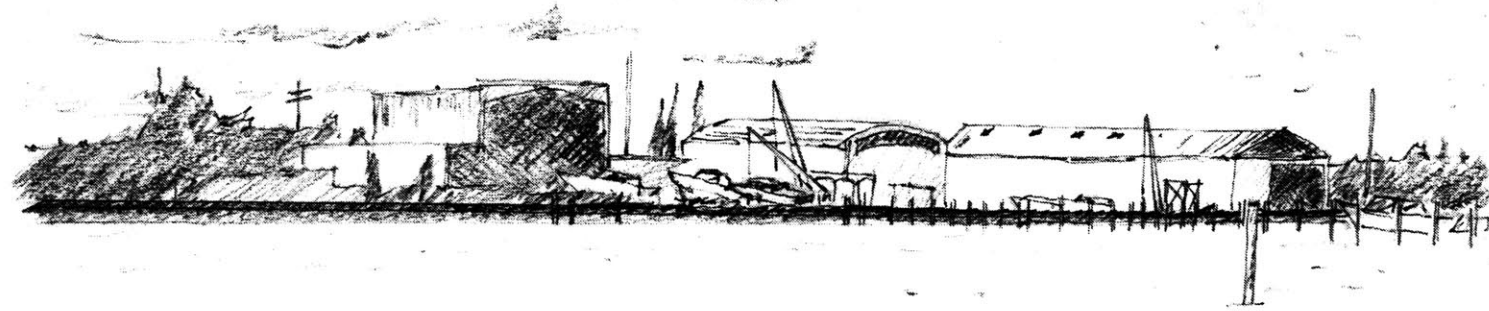

INDUSTRIAL EDGE:

Strength of the horizontal as one views across the water. Layering of horizontals from water to edge under dock, to land edge, to horizontal roof edges, to flat under-edge of clouds; punctuated by verticals of cranes, pilings and some trees.

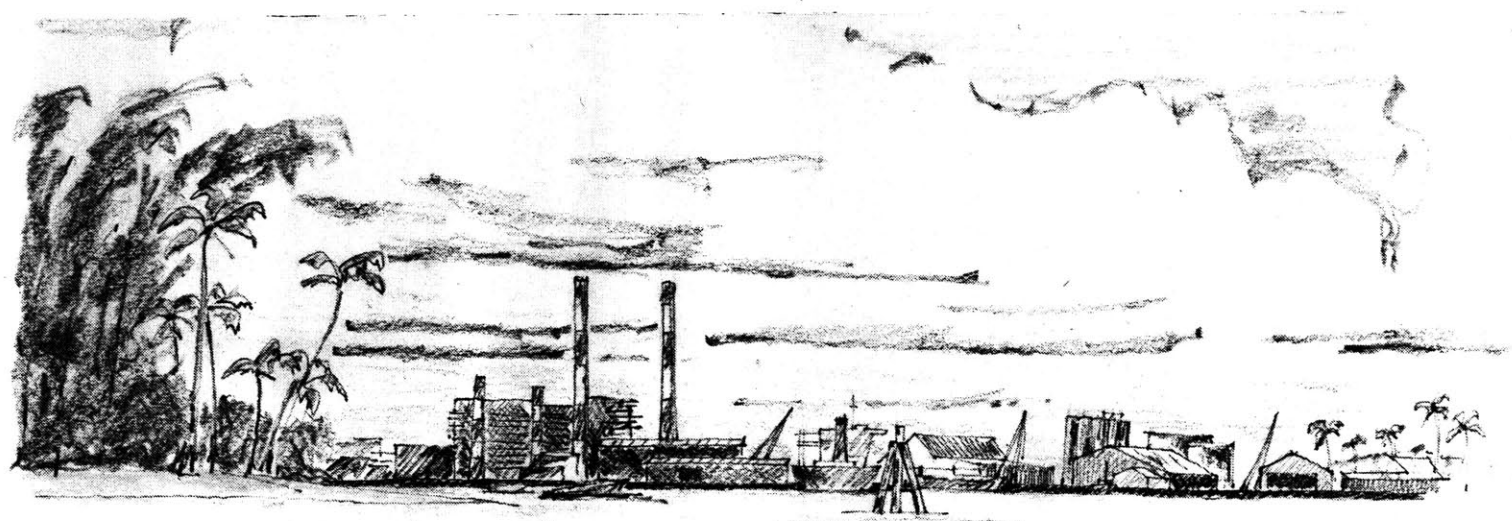

INDUSTRIAL EDGE:

Horizontals punctuated by vertical stacks, cranes, pilings and palm trees.

The overwhelming feeling of the landscape which adjoins the site area is one of horizontality. This is expressed by the flatness of the terrain, which only rises 5 to 10 feet above sea level in this immediate area. The surrounding water and the docks reinforce the strong horizontal movement as one sites across Lake Worth and out to the horizon at the Atlantic Ocean. The island itself punctuates this by its vertical rising above the Lake to 25 feet above sea level. The sheer amount of the land mass and its blanket of tall trees give it a strong figural quality in its environment. It takes on qualities of Center or Goal as one views it from the shore or from a boat at some distance from the island. The industrial landscape contributes to the vertical movement, with the addition of cranes, tall exhaust stacks and large liquid container tanks. Although somewhat dispersed, these elements do tend to 'gather' the industrial place into a total image that expresses its local character.

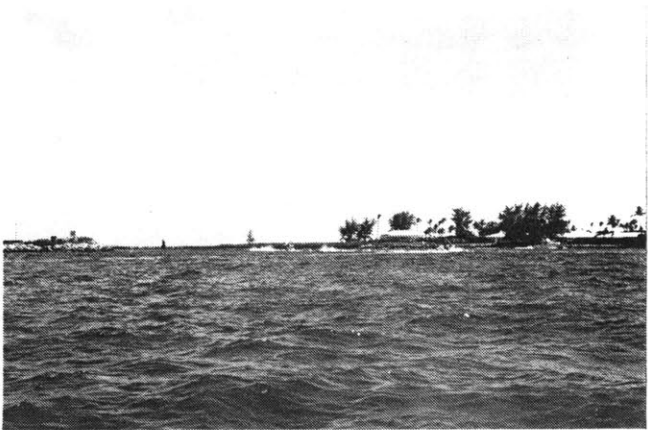

View toward Ocean and Inlet

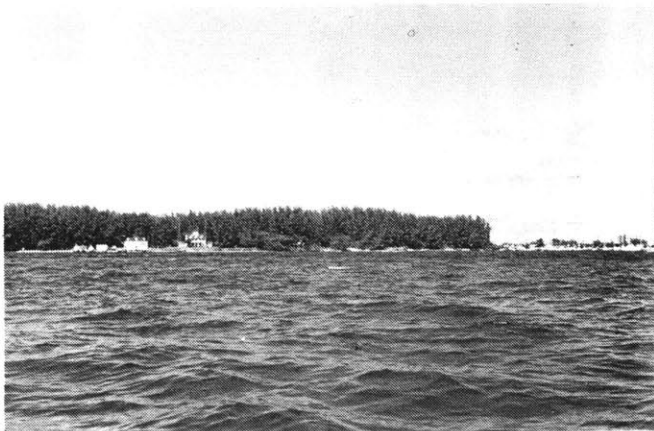

View toward Coast Guard Station

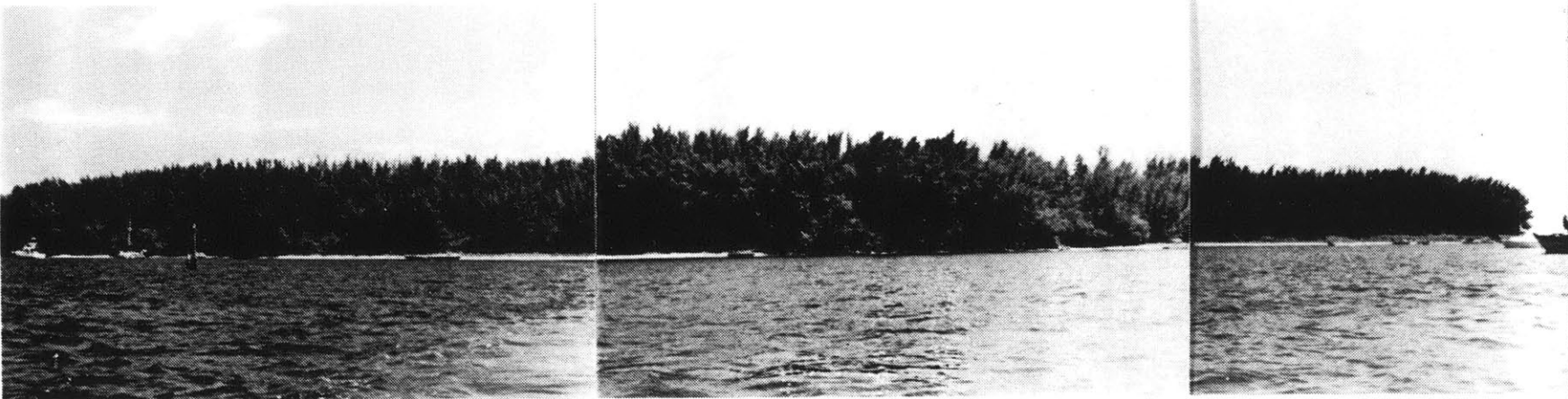

Island Site



Sketch looking at northern end of Island thru Riviera Beach Bridge

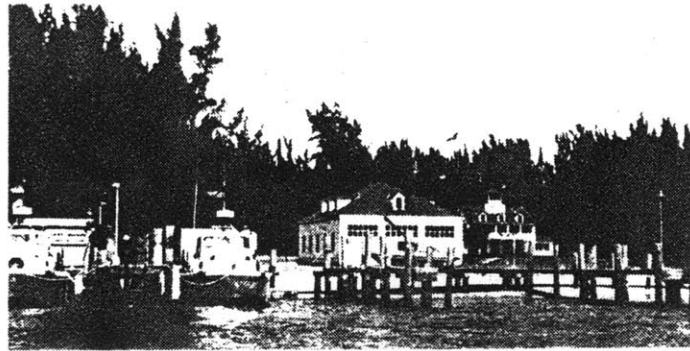
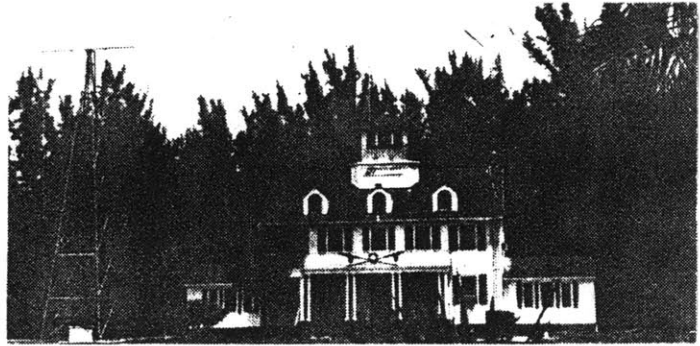

EXISTING COAST QUARD STA.
50 year old vernacular
wood frame buildings.
Layered horizontals sharply
defined by vertical wall
of Australian pines.

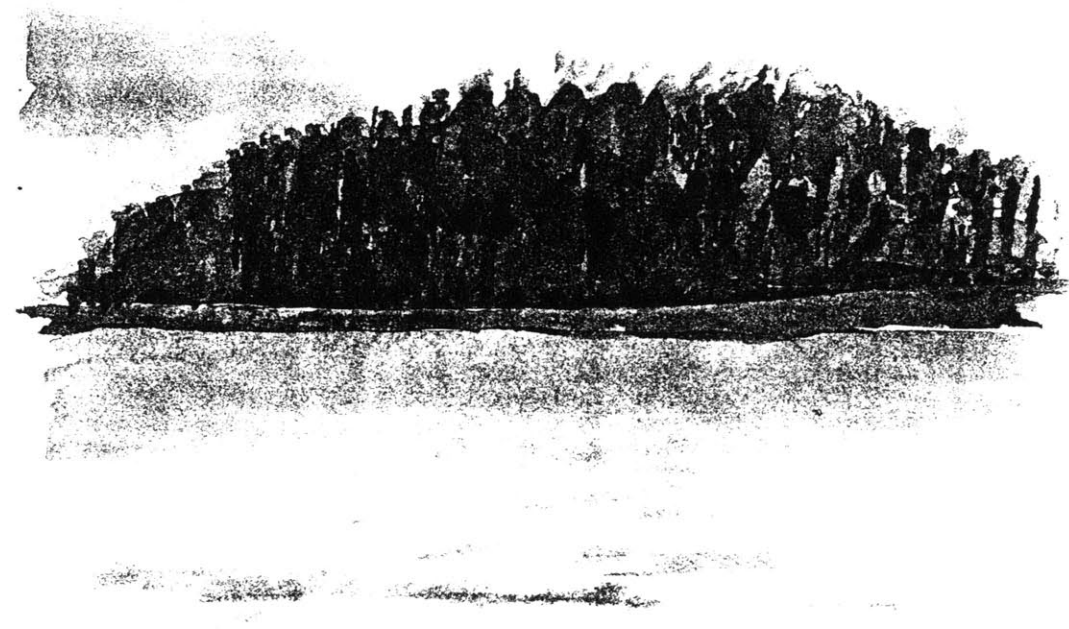
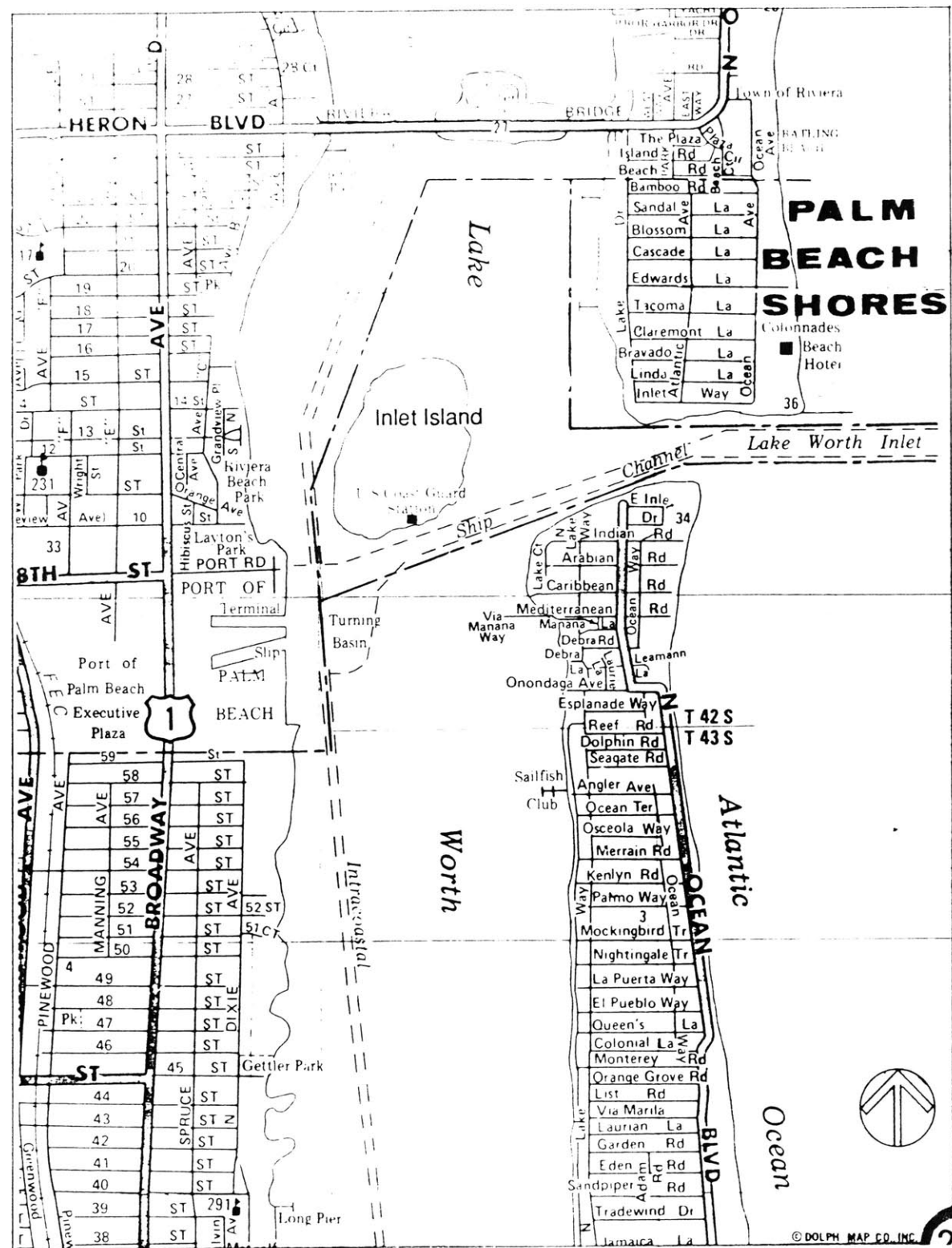

watercolor sketch of Island

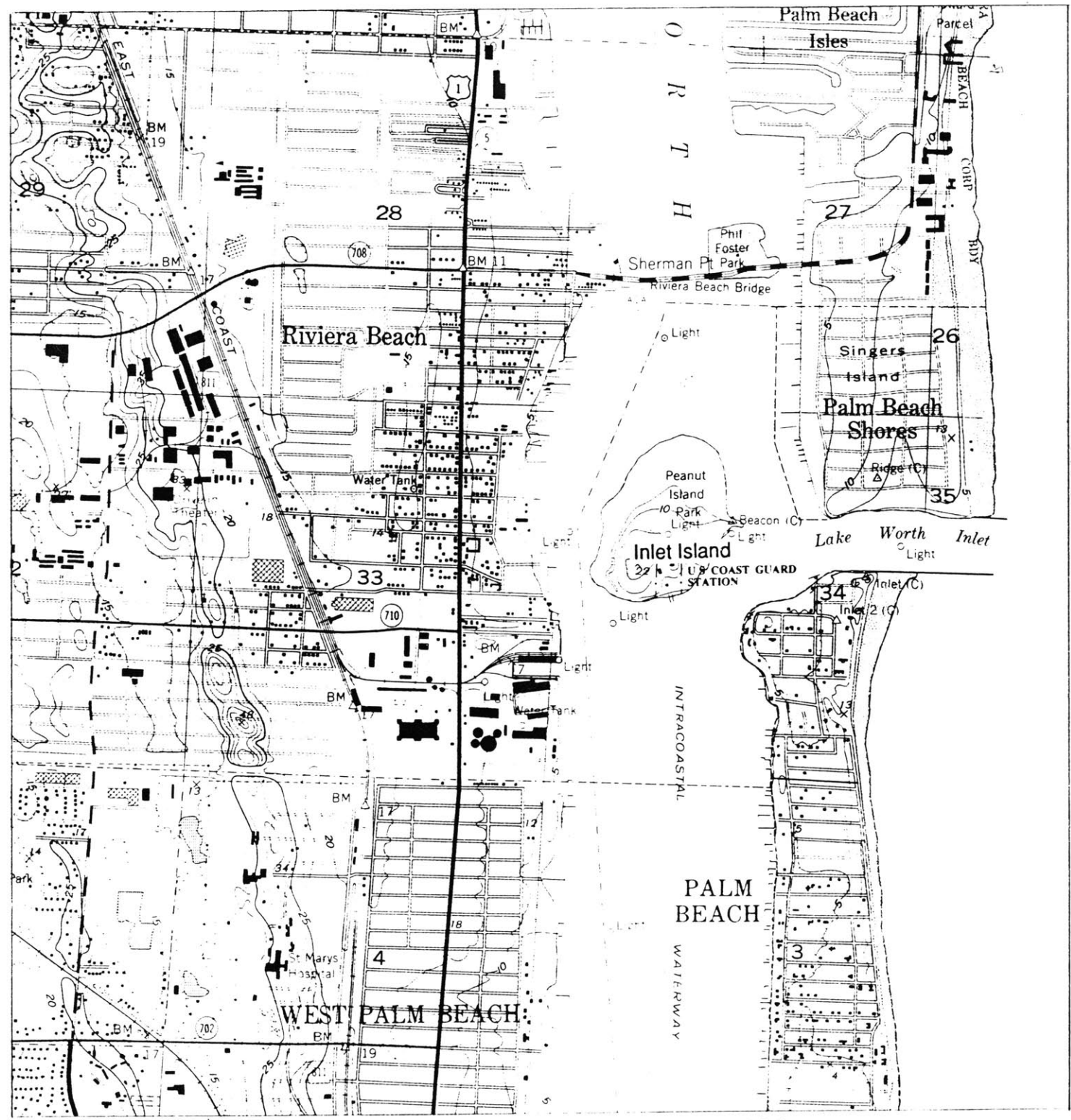

PROGRAM



ADMINISTRATION total: 4300 sq.ft.

Offices	1900
Sponsored Programs	300
Public Information	600
Conference Room	300
Development	150
Xerox/Mail	1000

DOCKING FACILITY total: 5400 sq.ft.

Shipping & Receiving	1000
Marine Resources & Living Material Supply	800
Machine and Electronic Shop	900
Carpentry Shop & Boat Repair	1700
Instrumentation Development	1000

LAB BUILDINGS total: 17,020 sq.ft.

5 buildings at total: 68,030 sq.ft.

Laboratory (28 at 395 sq.ft. - large Lab building)	11,060
Reception/Waiting Area	460
Secretarial	320
Meeting/Conference Rooms (3 at 670 sq.ft.)	2010
Lounge/Kitchenette	670
Coffee Lounge	320
Chemical Preparation & Storage (2 at 325 sq.ft.)	650
Refrigeration & Autoclave (2 at 360 sq.ft.)	720
Large Microscope Room	320
Photolab & Dark Room	190
Graphics/Xerox	250
First Aid	50

LIBRARY total: 27,935 sq.ft.

Offices/Work Rooms	1750
Reading Rooms (2)	2650
Archives Center/Xerox	1600
Conference Room/Kitchenette	525
Study Rooms (12 at 50 sq.ft.)	600
Group Study Room/Typing	300
Storage	2600
Audio-Visual	400
Stacks	17,510

CONFERENCE CENTER - MARINE RESOURCES & POLICY total: 29,500 sq.ft.

Lobby /Arrival	1600
Offices	500
Guest Rooms (30 double occupancy rooms)	10,800
Dining Room/Kitchen	6500
Lounge/Sitting Room	600
Meeting Rooms (5)	2875
Lecture Rooms (3)	3800
Auditorium (200 people)	2800

DESIGN: Site

Observing the physical language of the area surrounding the site begins to give a reading of what elements an intervention might consist of. The horizontality is an enormously strong force and one that must be acknowledged in some way. Since the physical fabric of the opposite shores is so antithetical, the character of the Program pieces will be a synthesis of those forms; both the industrial and the Mediterranean vernacular will be transformed for use in the buildings.

The site itself is probably best described in Norberg-Schulz' terminology as belonging to the 'Romantic Landscape' genre. He describes that landscape as one in which the forces of nature are present through changes of weather, through the presence of water as a dynamic element, through a "multitude of different places" and because the sky is generally inaccessible due to the denseness of the tree canopy which filters light and produces shadow. The island has a strong directional movement going from south-west to north-east. This is reinforced by the island's edges or shores as well as by the topographic features of the hill contours.

The project site lies next to the Coast Guard station to its west, and continues up the windward side of the higher of the two hills. The southern edge of the island is seen as most desirable for development of the Facility for several reasons. Its immediate access to and from the existing ship channel means that an alternate large boat access need not be considered. At this location, the proximity to the industrial edge is seen as an appropriate relationship. (This channel and the Intracoastal Waterway to the west of the island act as waterway 'streets' for ship and boat traffic) Climate considerations were also a factor in the choice of site. On this side of the island, the site receives the prevailing breezes directly as they blow across the lake from the Atlantic. It has views toward the ocean as it turns its side to the glare of the sun setting low in the western sky. A portion of the site is also able to receive shading by vegetation from the evening sun. While the site is protected by the rest of the island from the harsh winter winds that can blow from the north-west, it is somewhat exposed to hurricane winds, should they come from the south-west or south-east, although there is landmark protection provided by the northern tip of Palm Beach Island and by the land mass of the mainland.

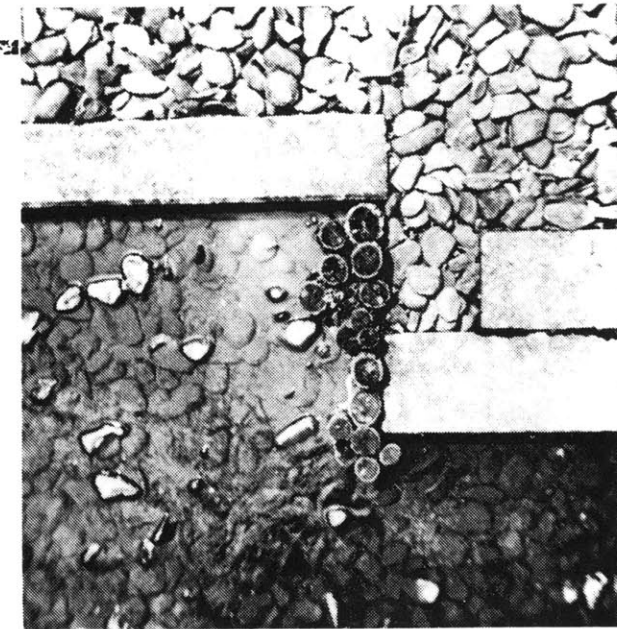

Directional Movements

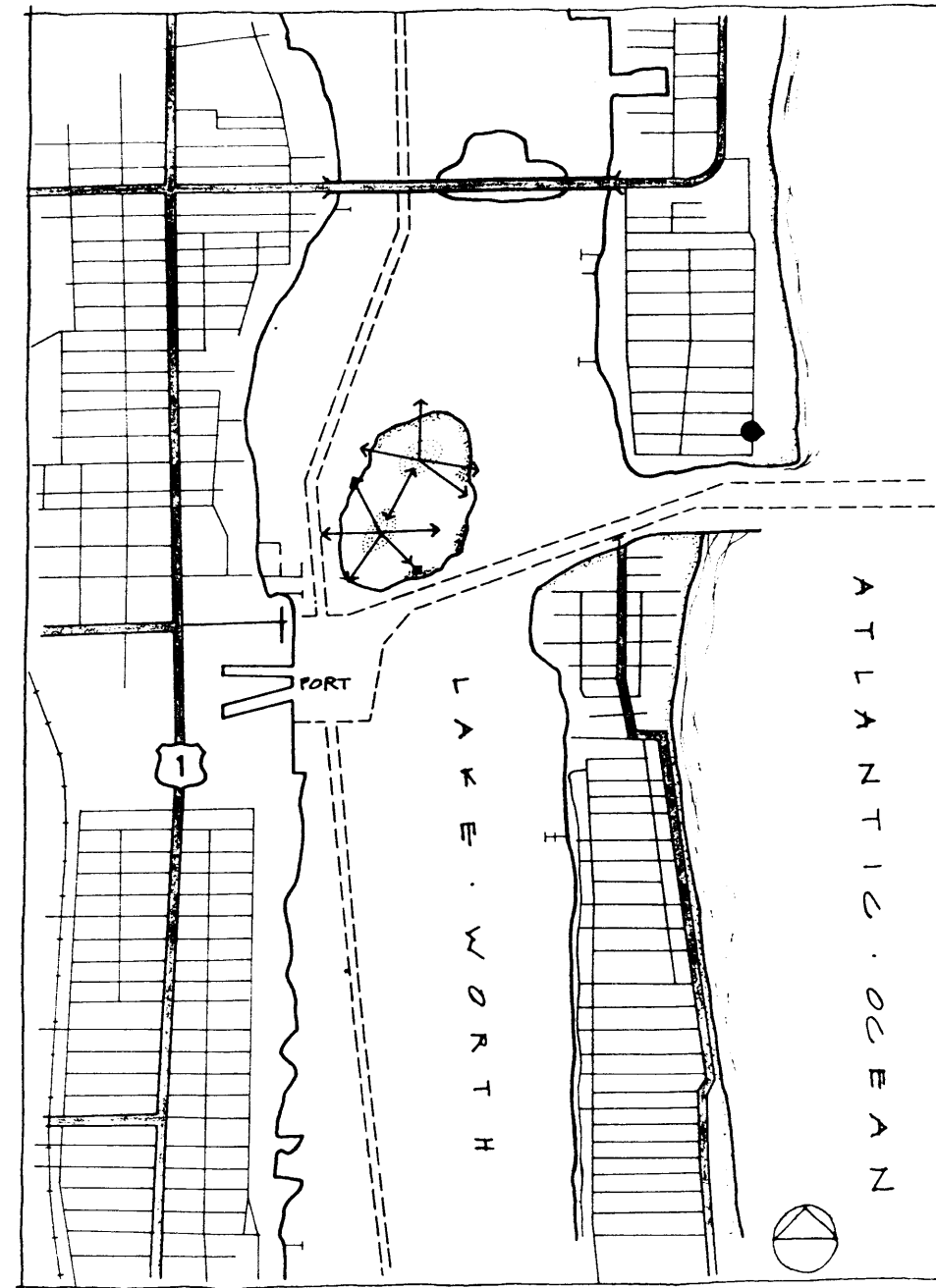
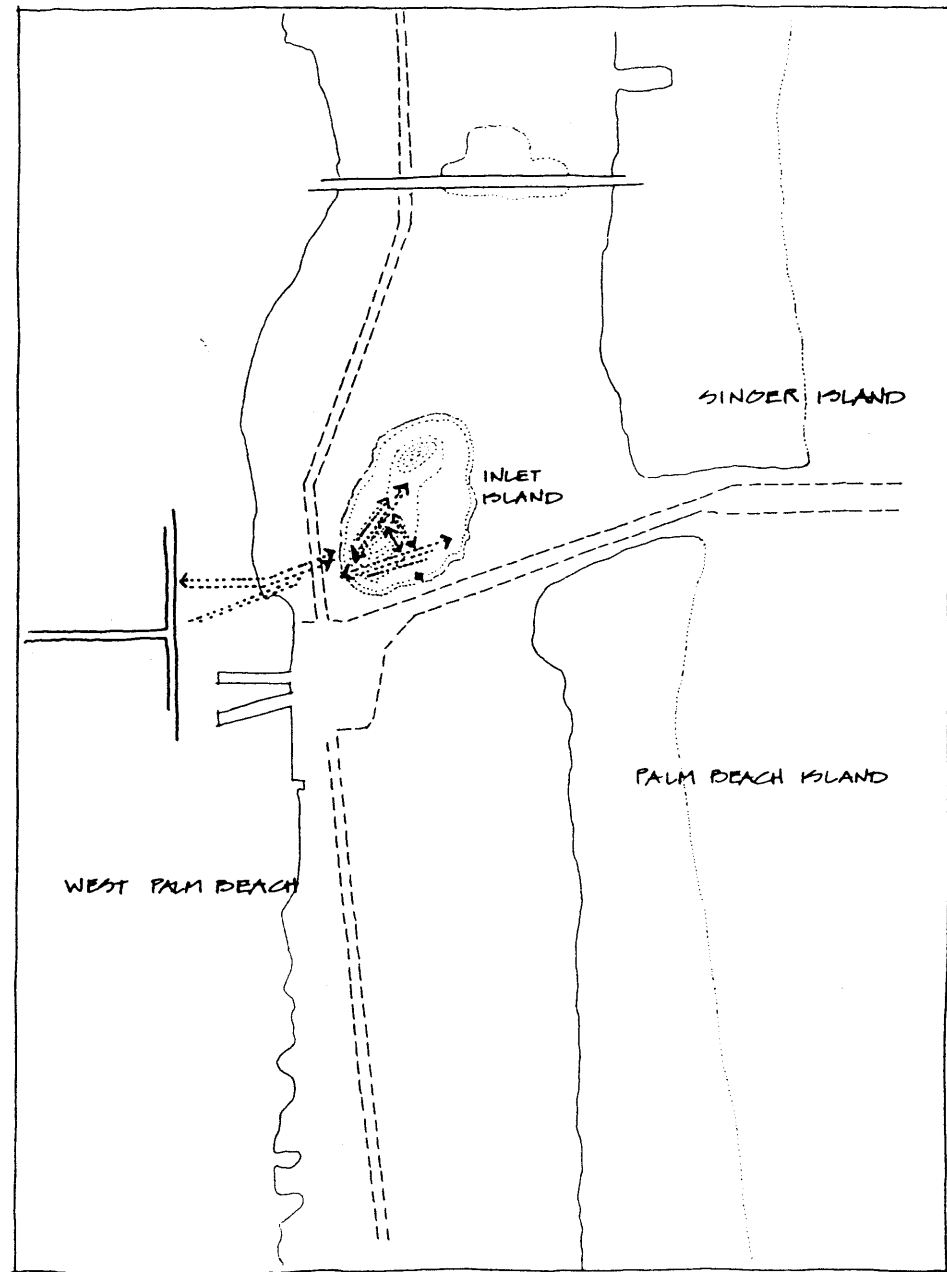

This point on the island is the most advantageous for accessing from the mainland. A main traffic artery is easily directed through a section of the industrial block and across the Lake. Since the Intracoastal waterway must be maintained for large pleasure craft, the proposed bridge will be of the swing type to allow higher craft through. Boats under 15 feet will be able to pass directly under the bridge. (Lake Worth has 4 draw bridges in constant use spanning it now from West Palm Beach to Palm Beach Island) The bridge is a necessity to service the Facility and for workers and scientists to gain access. There will be a pedestrian walkway leading from a parking area on the mainland across the bridge and connecting to a system of wooden deck paths and fishing docks, a rustic comfort area and a bike path. The continuity of this 'promenade' will move up the length of the island to public boat docking at its northern end. The pedestrian way is an important access because at present, only boaters can take advantage of the park-like qualities of the island.

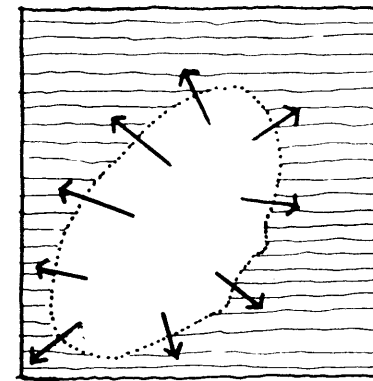

island

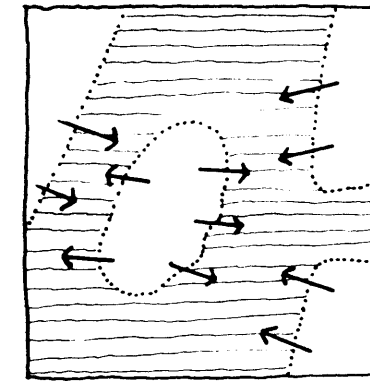

shoreline

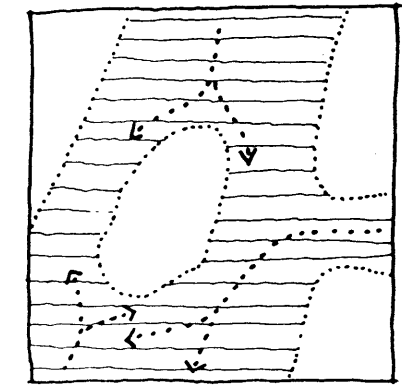

direction

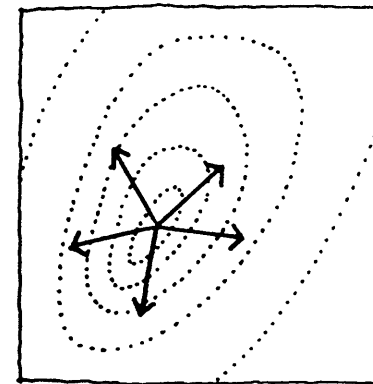

hill (plan)

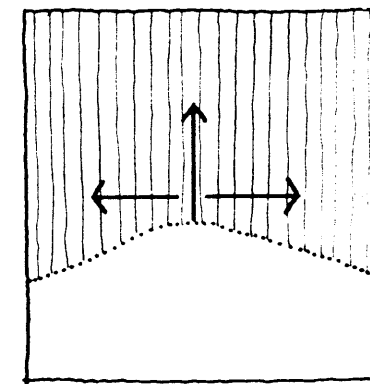

hill (section)

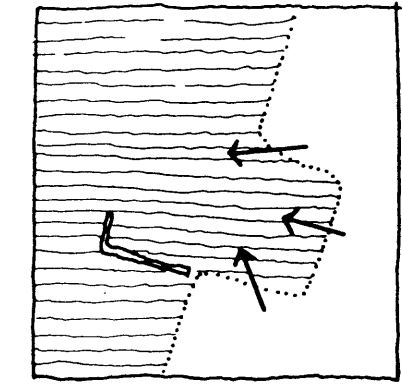

harbor

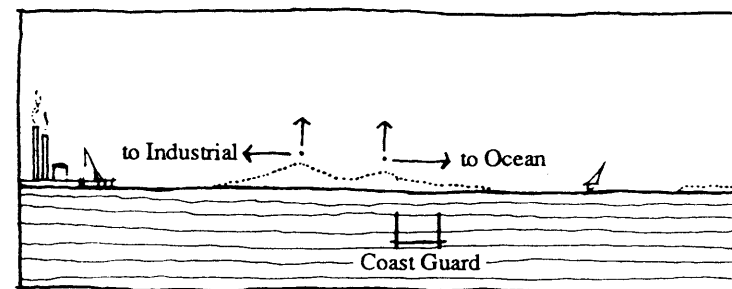

reference points

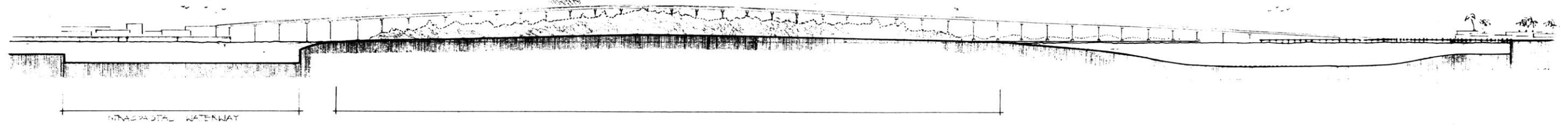

SITE SECTION 1
SCALE 1" = 100'
0 50 100 FEET

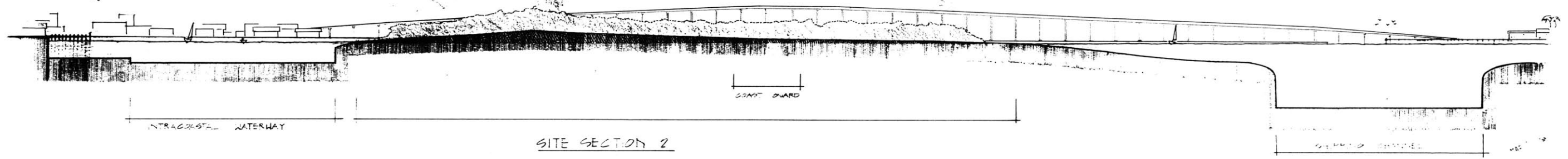

SITE SECTION 2

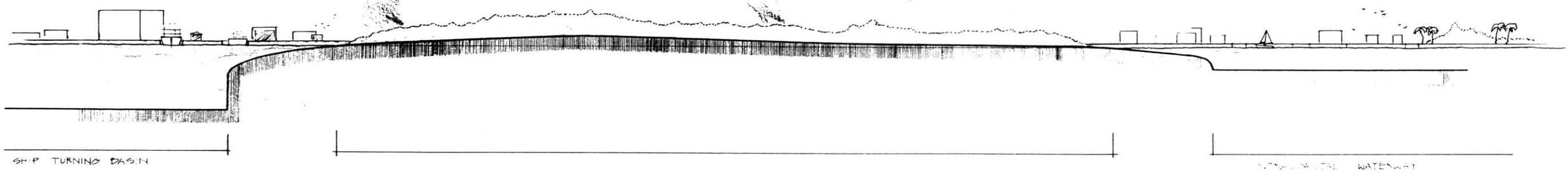

SITE SECTION 3
SCALE 1" = 100'
0 50 100 FEET

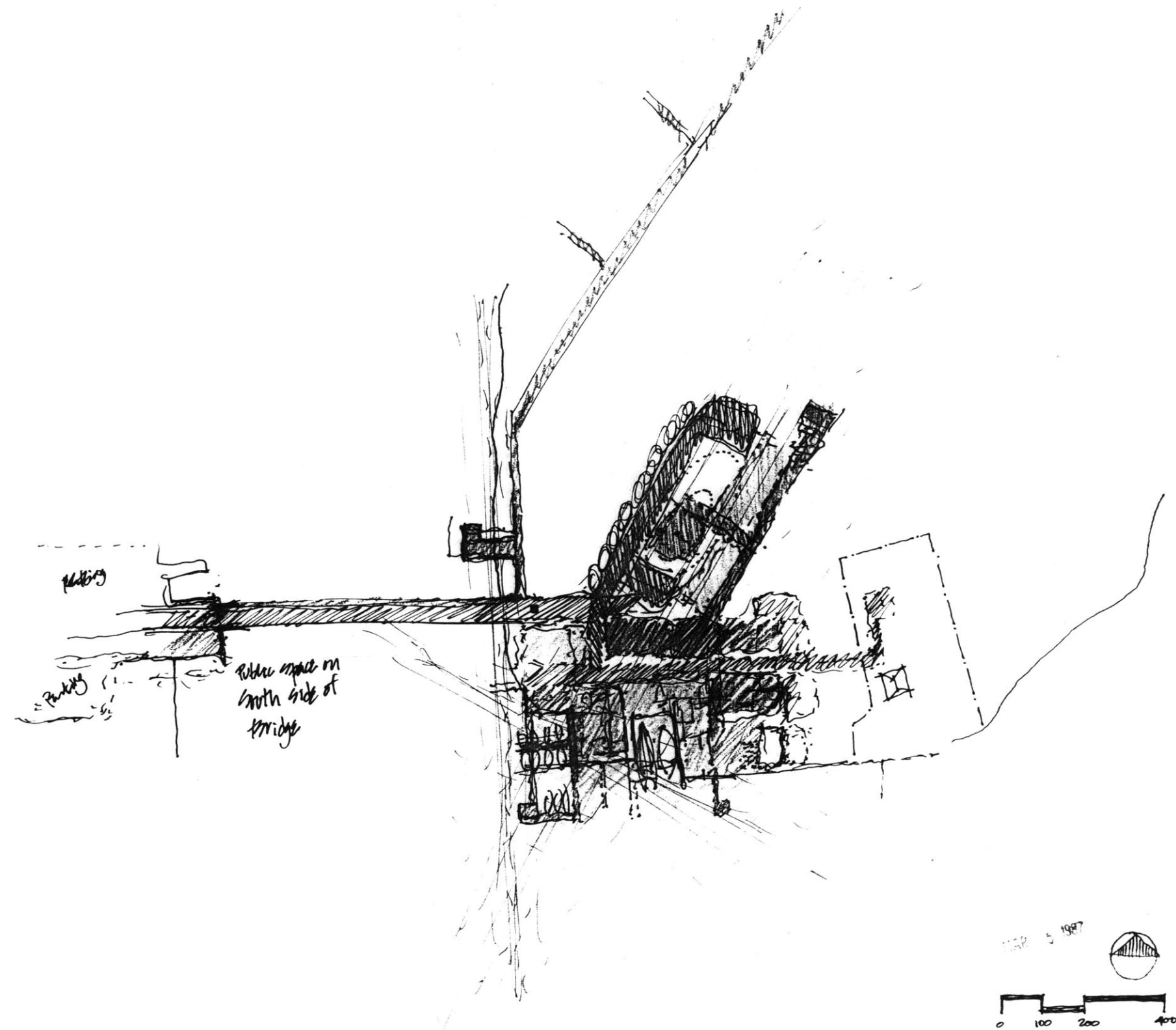



DESIGN: *Building*

As the proposed bridge approaches the island, a section of edge to the south if it 'gives way' to allow it to touch down on land. The sense of islandness is experienced on crossing as one views the edges, one built and one natural.

The Labs are located in a direct relationship to the water and begin to intensify the edge as the docks move out horizontally to connect with the life of the water world. The docks and work areas are constructed in two ways. There are concrete foundation walls that are land-based and define an edge that is connected to the former edge of the island. As a dock moves out over the water, it is perceived as water-based and therefore becomes pier-like and is constructed of concrete piers.

A 'perambulatory' pedestrian system, consisting of covered walkways, takes up the directional movements present on the docks. The orthogonal direction is an extension of the mainland's grid, while the dominant movement is a reflection of the island's own strong directionality. This direction continues up the hill following the landscape. Program pieces have some connection to the

'perambulatory'. In some instances buildings replace the function of covered walks with loggias that define the edge of the building at that point. As the walk moves up and through the landscape, it defines areas of horizontality that are stopping places where it is possible to view out to the ocean, back toward the terraced gardens, or at its end to sit in the sun at poolside.



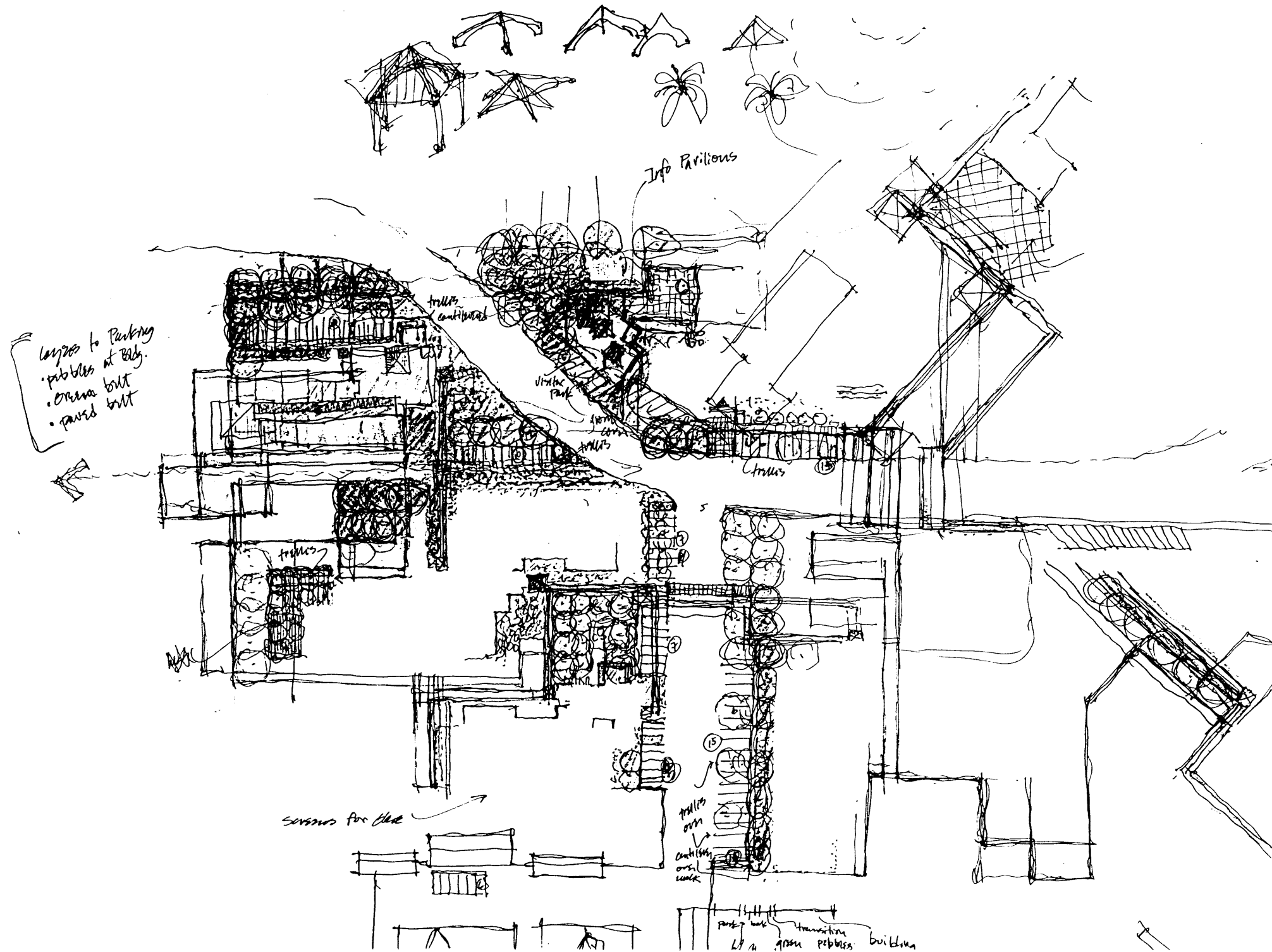

The primary structural system of the Lab buildings are concrete 'veins' formed to create a thick zone that on the interior side is used for work tables that span the 'vein', for exhaust hoods and for service and mechanical tubes and pipes. This area is also the threshold zone for entry into the individual Labs. Alternating with the service zone is an opening that allows for natural ventilation up and out through the monitor roof during the months when it is cooler and there is relatively little humidity. 'Veins' on the outside edge of the Labs are for the movement back and forth of the secondary closure system. Their position within the wall will change depending upon the orientation of a particular building.

The Lab buildings are organized so that the pedestrian movement will shift slightly after entering and then, with views out through the open and light 'connector' piece, will continue out towards the water. A secondary 'street' accesses the Labs with the pavilion-like Meeting Rooms drawing one through and out to the water or landscape. At the second level, this 'street' is defined by a clerestory monitor.

Sun and glare is regulated by a system of operable shutters that can be slid across the window surface as needed. They are attached away from the window so that air can circulate through. A non-structural concrete shelf spans between the primary structure walls and acts as a shading device for the window below.

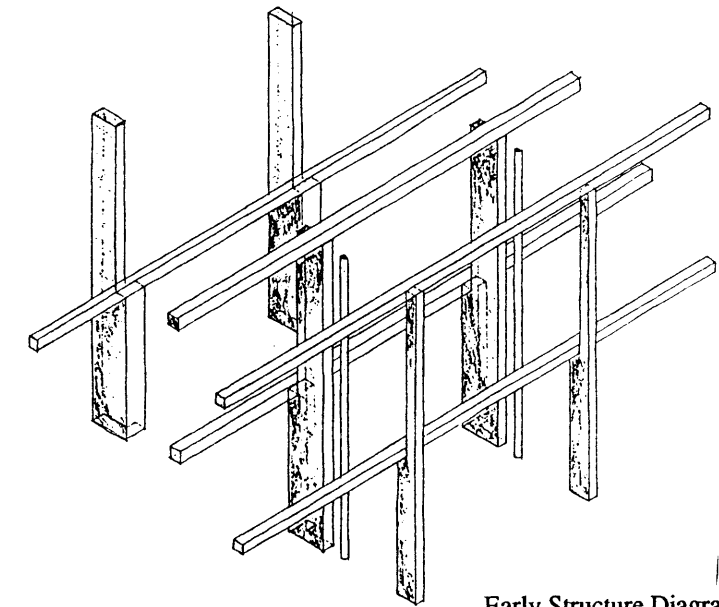
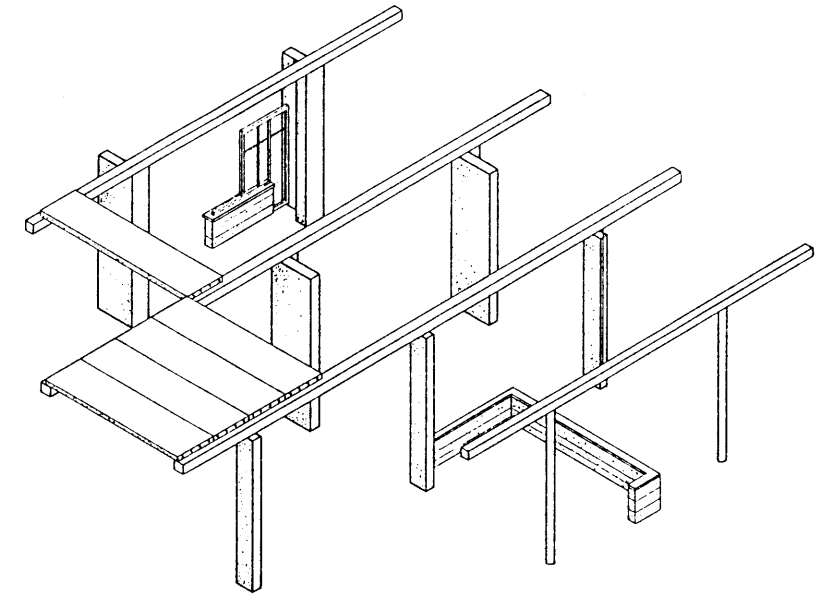

Early Structure Diagrams

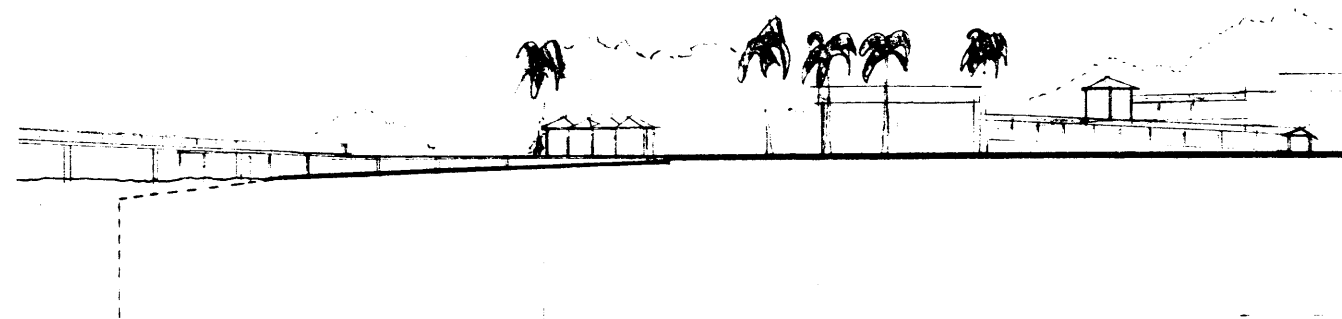

VISITOR
INFO

ADMINIS

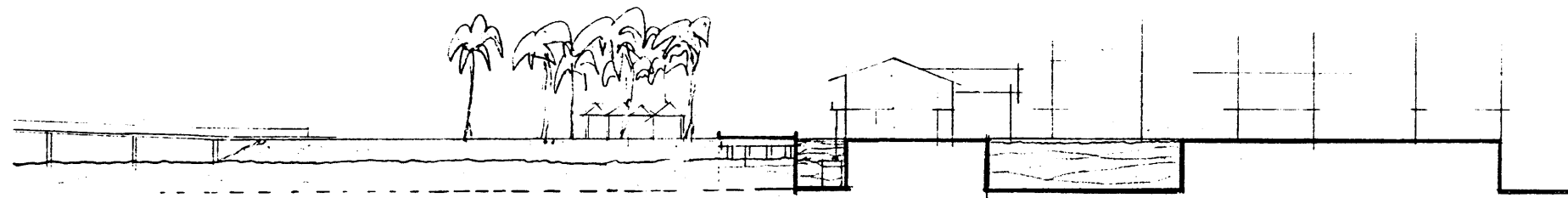

Early Site Sections



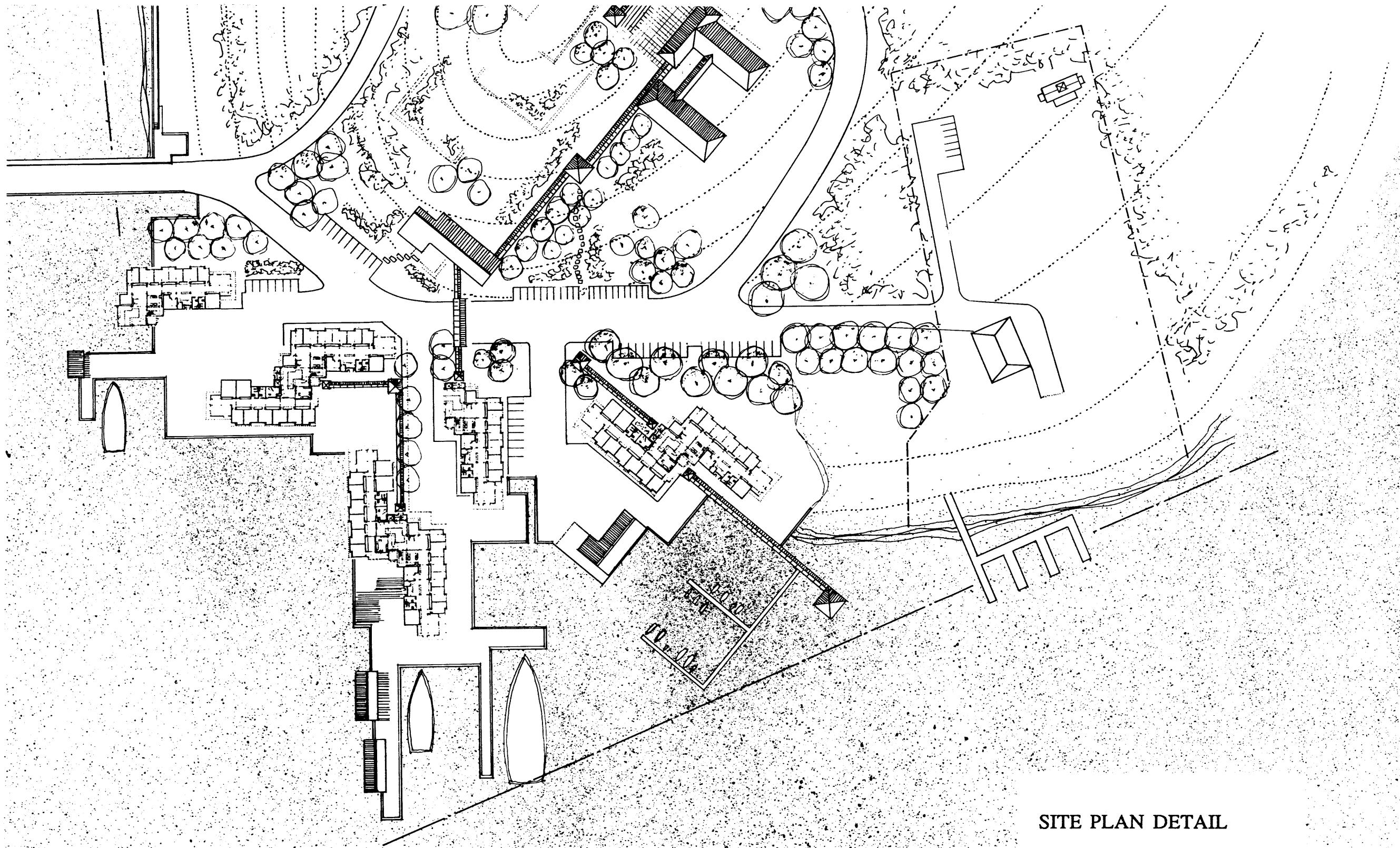

SITE PLAN DETAIL



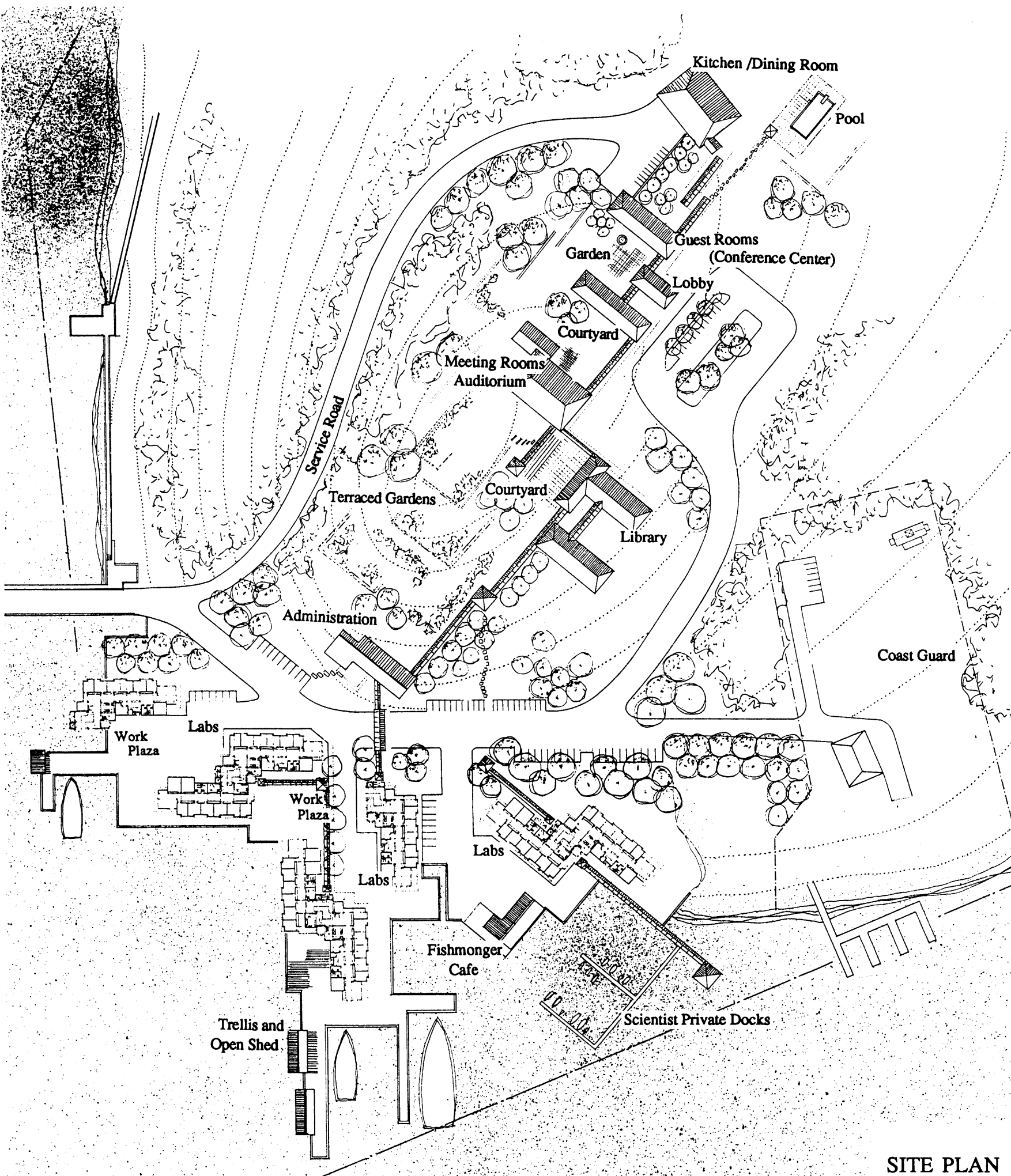

SITE PLAN

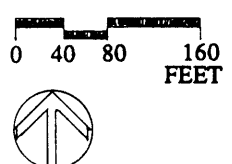

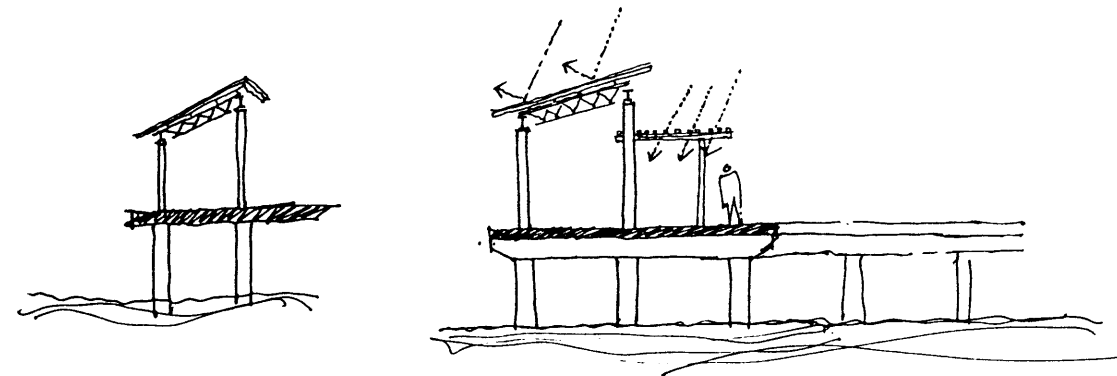

Trellis and Open Shed at Dock Edge

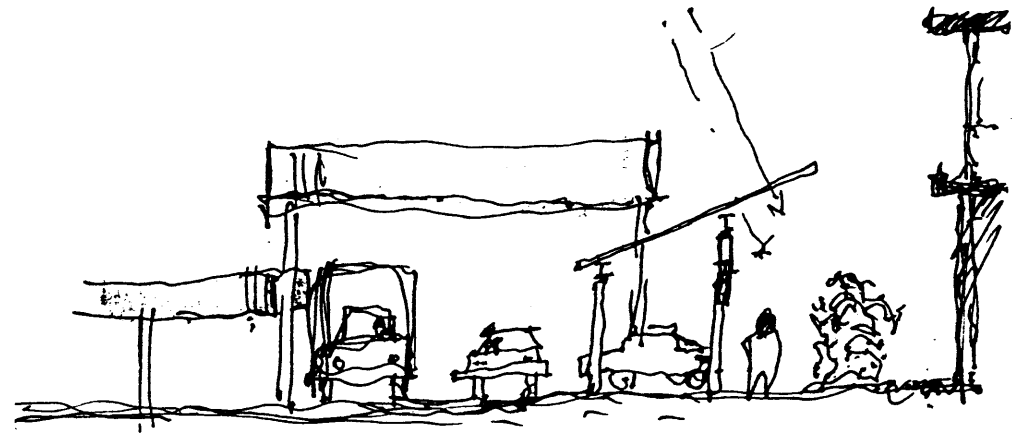
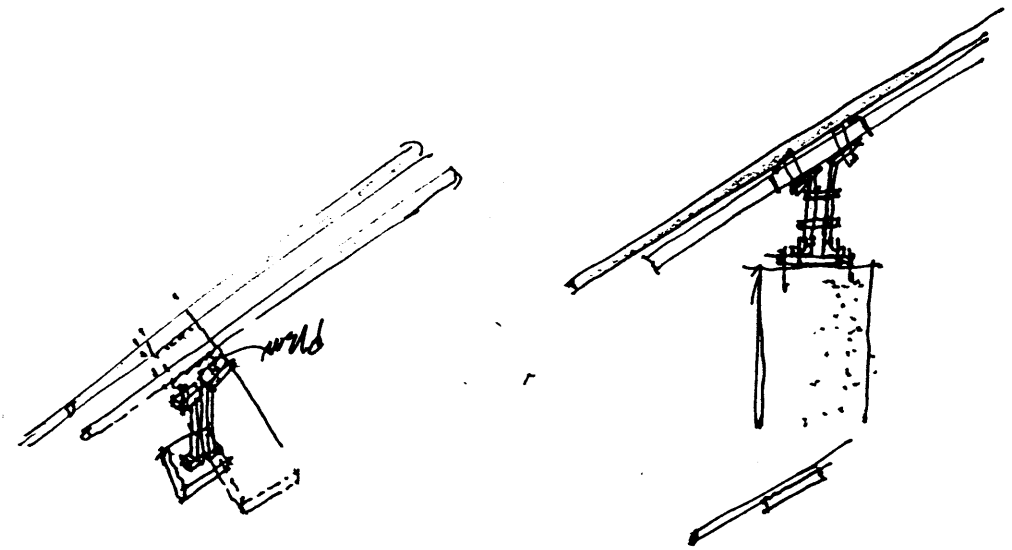

Trellis Detail over Parking Areas

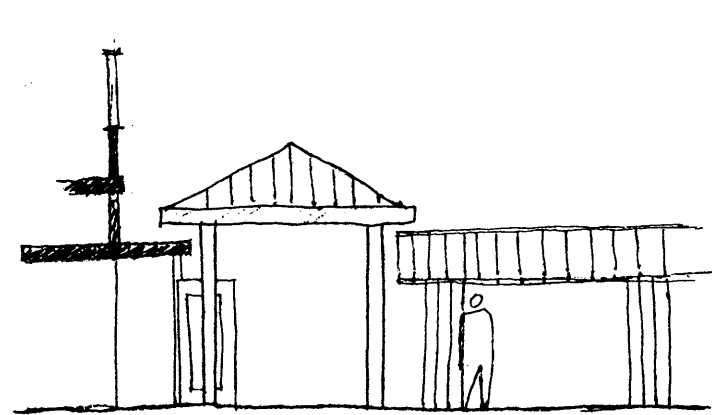

Perambulatory

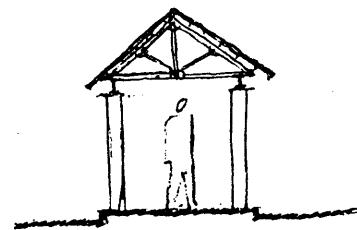

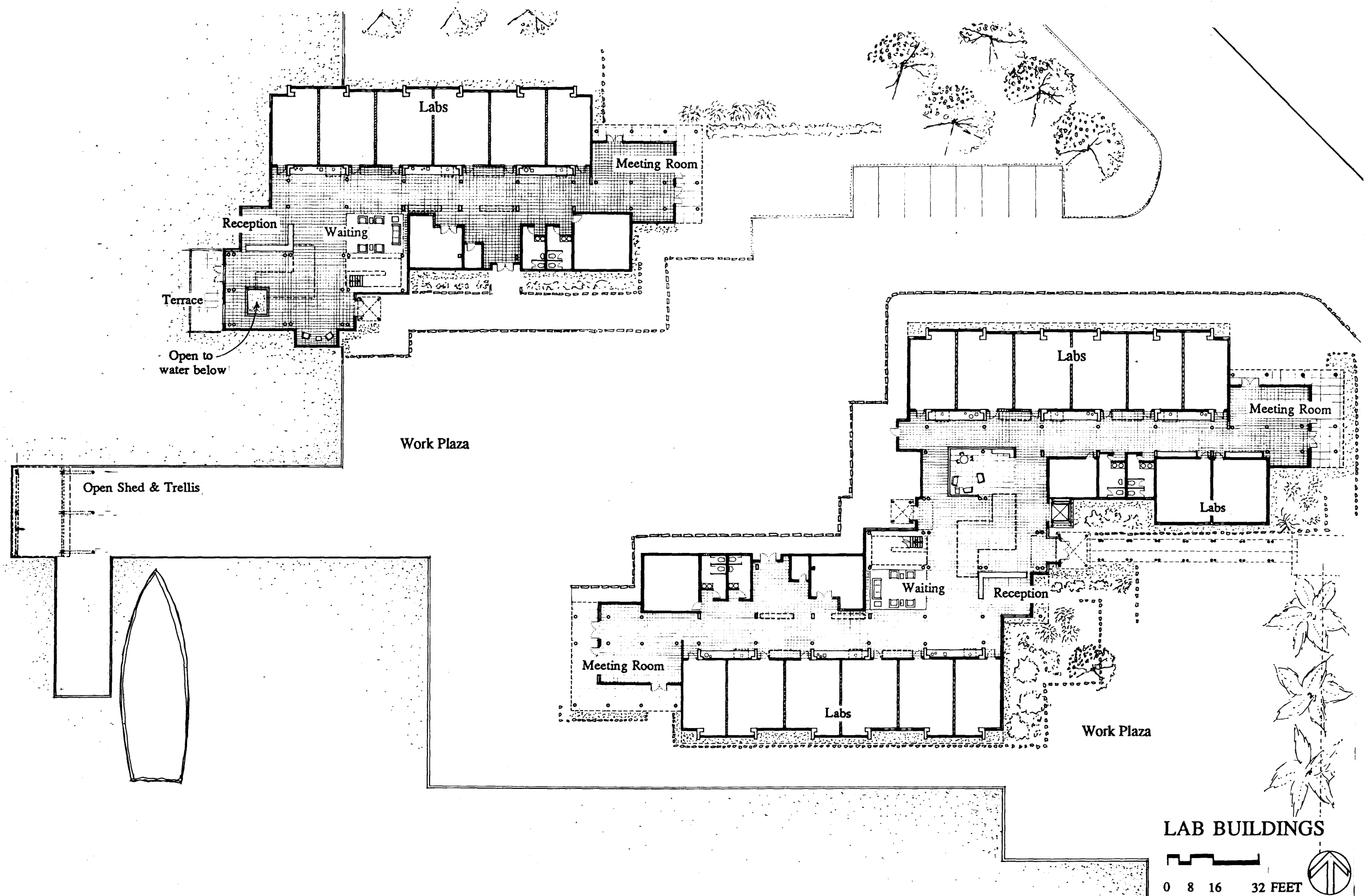

LAB BUILDINGS

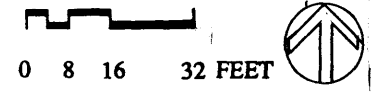

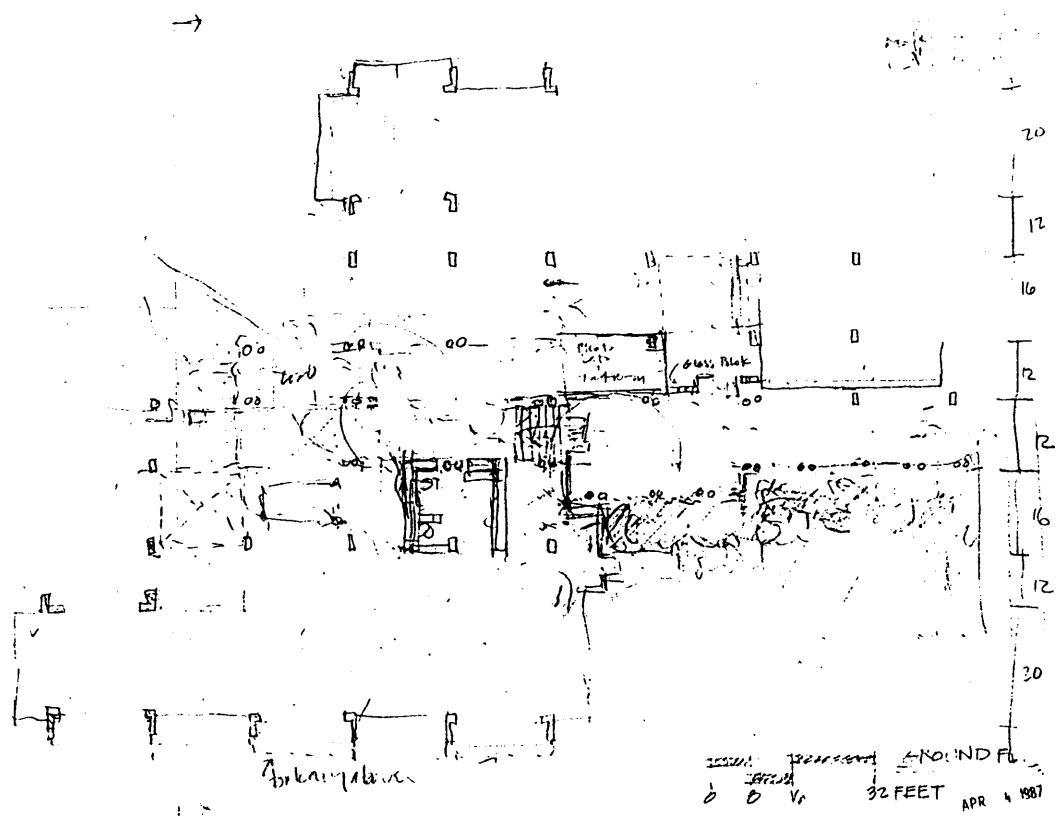

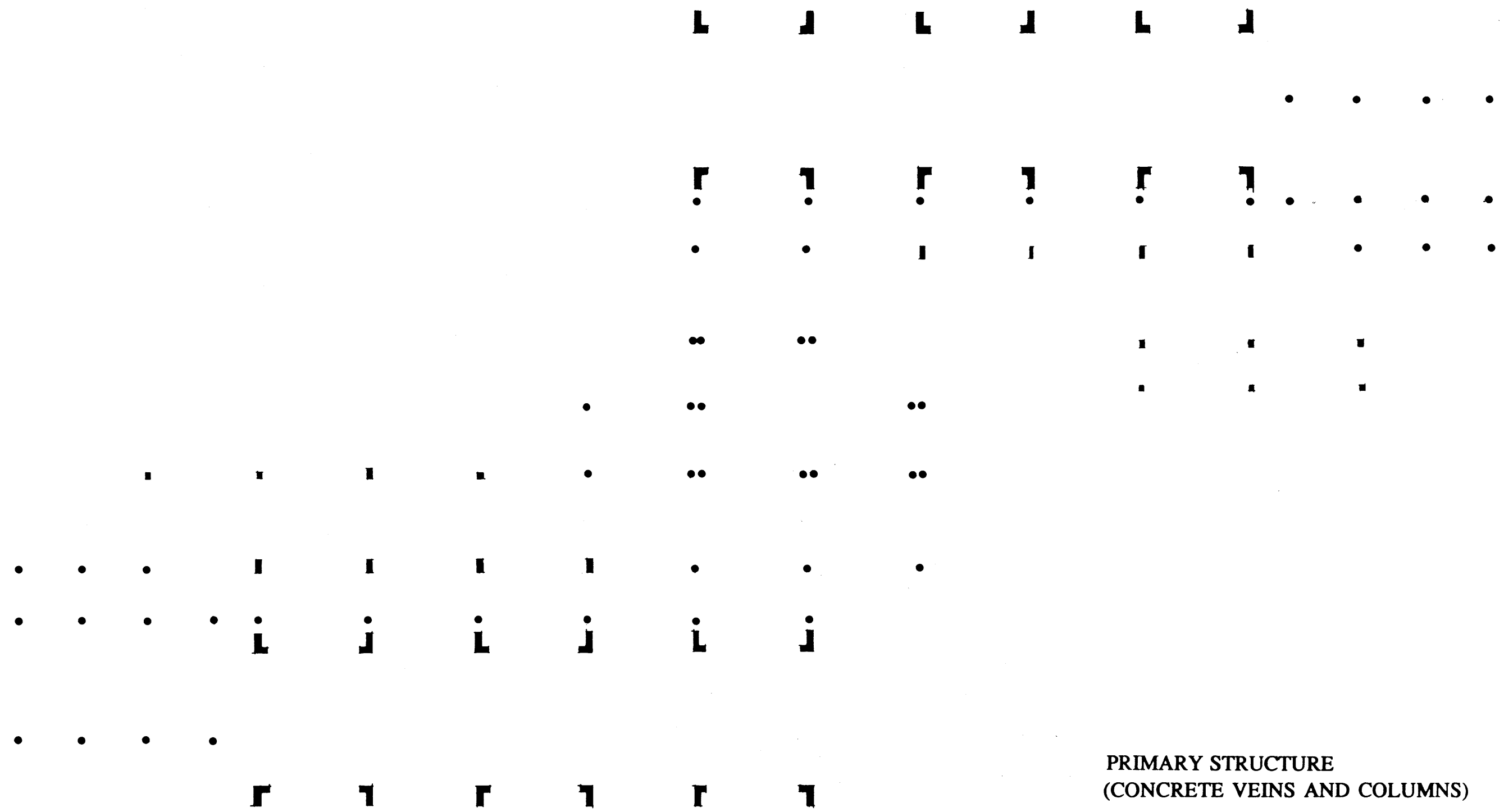

PRIMARY STRUCTURE
(CONCRETE VEINS AND COLUMNS)

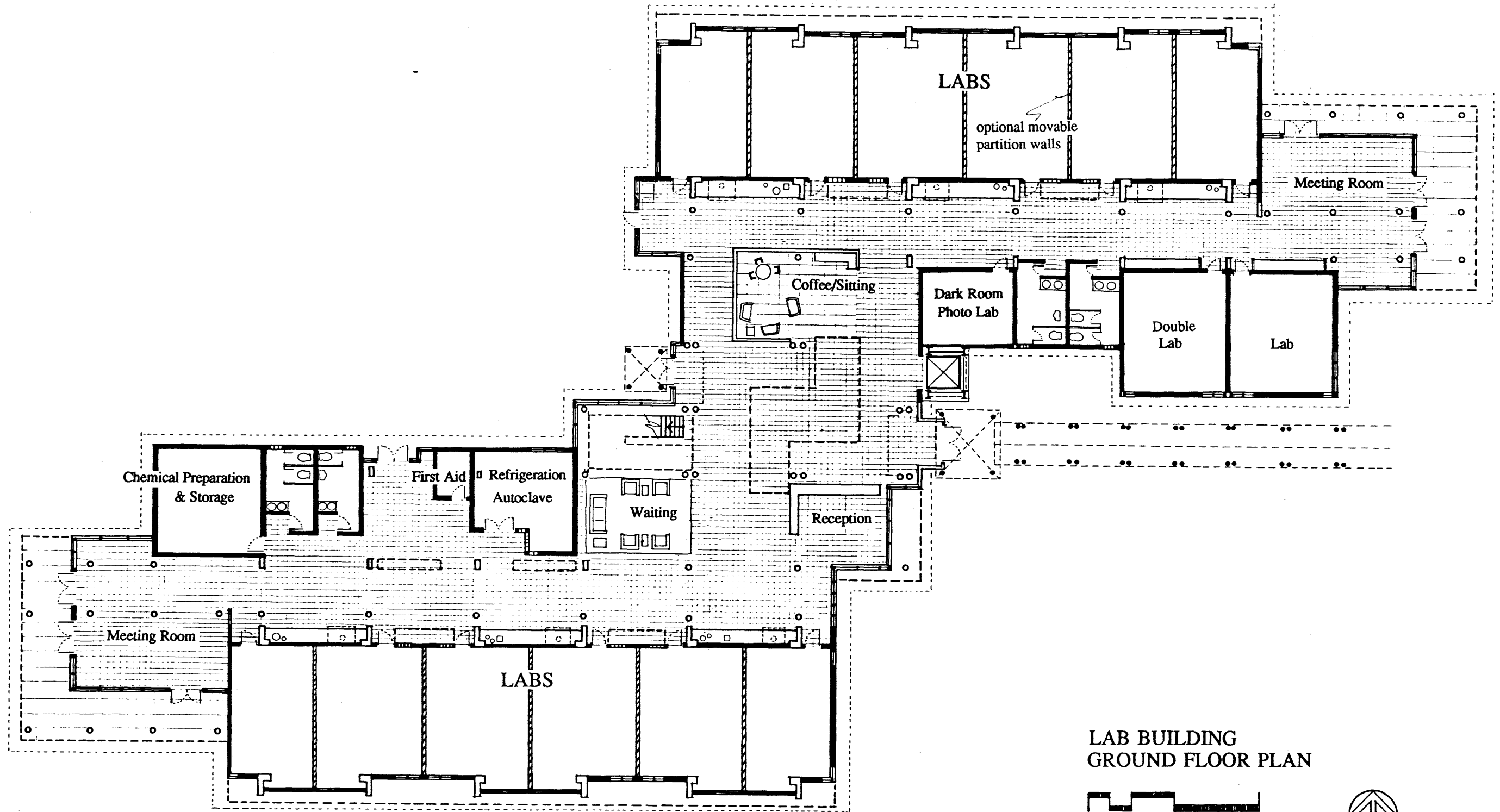

LAB BUILDING
GROUND FLOOR PLAN

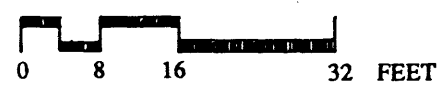

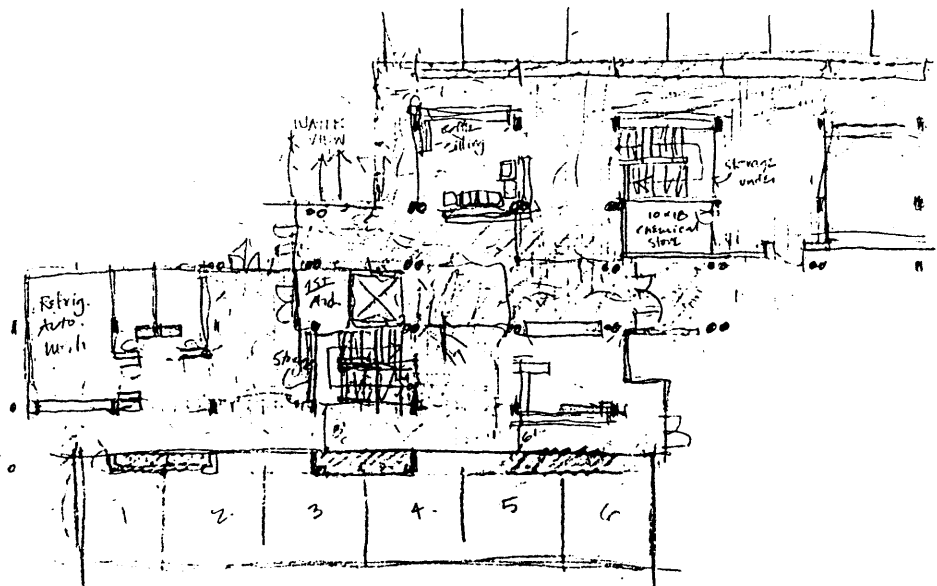
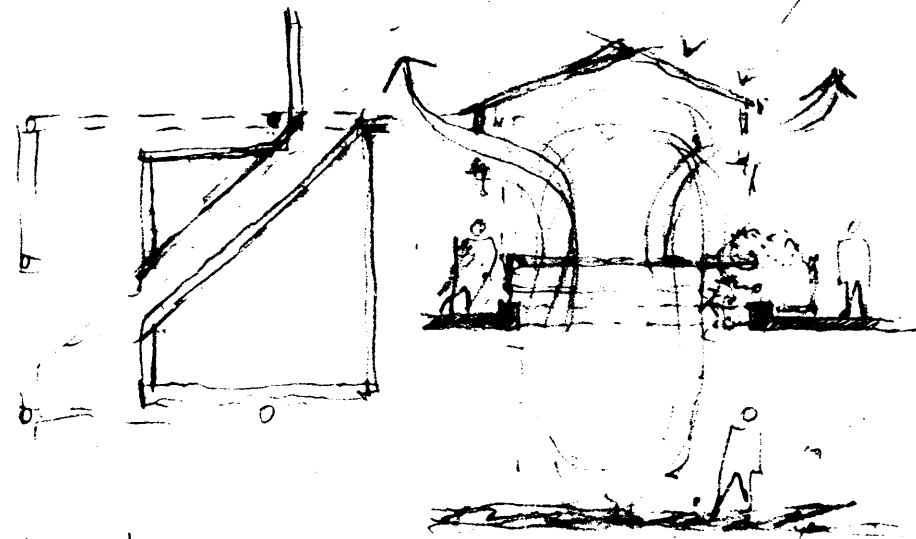

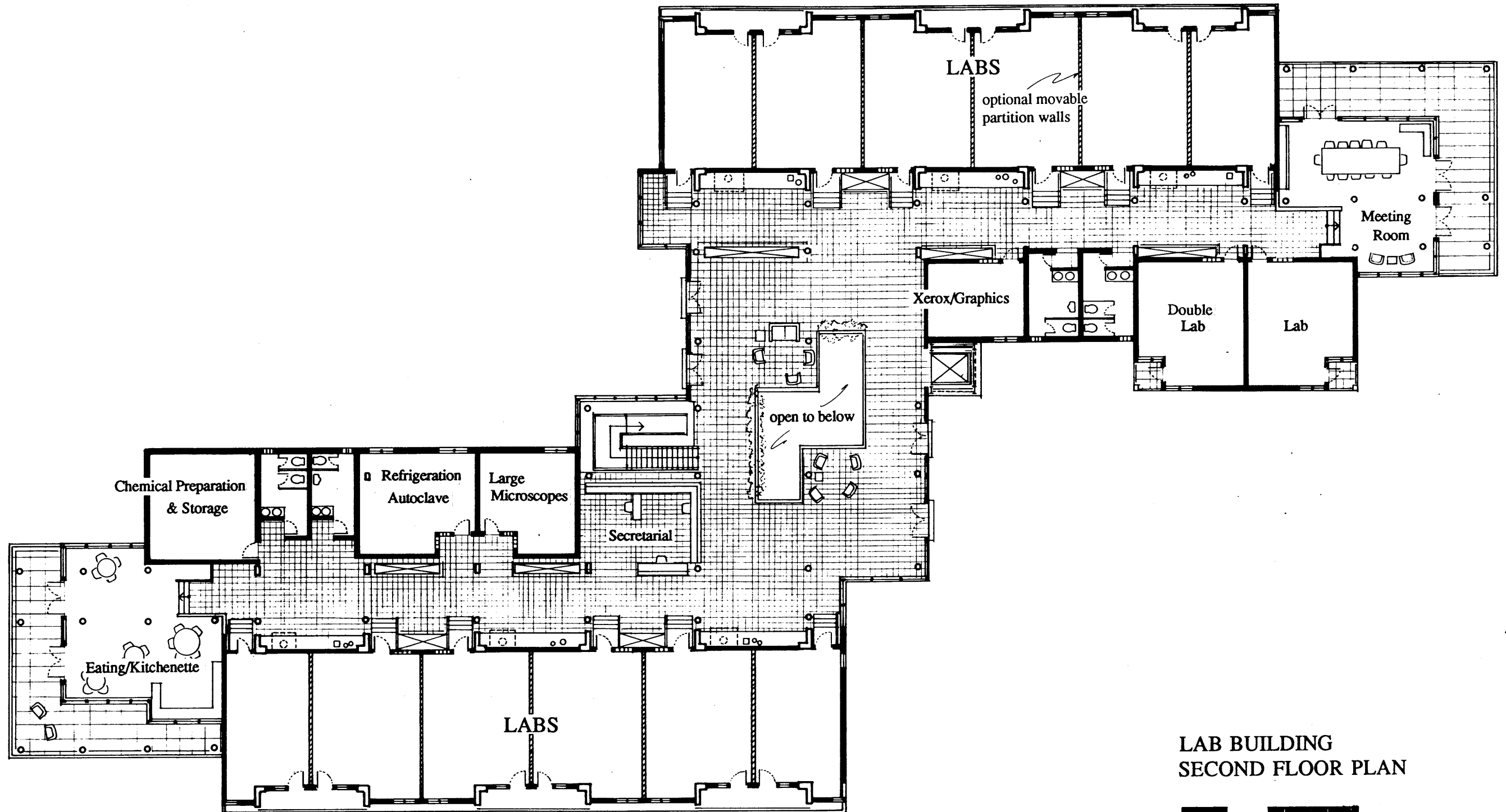

LAB BUILDING
SECOND FLOOR PLAN

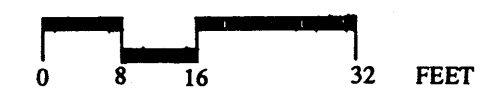

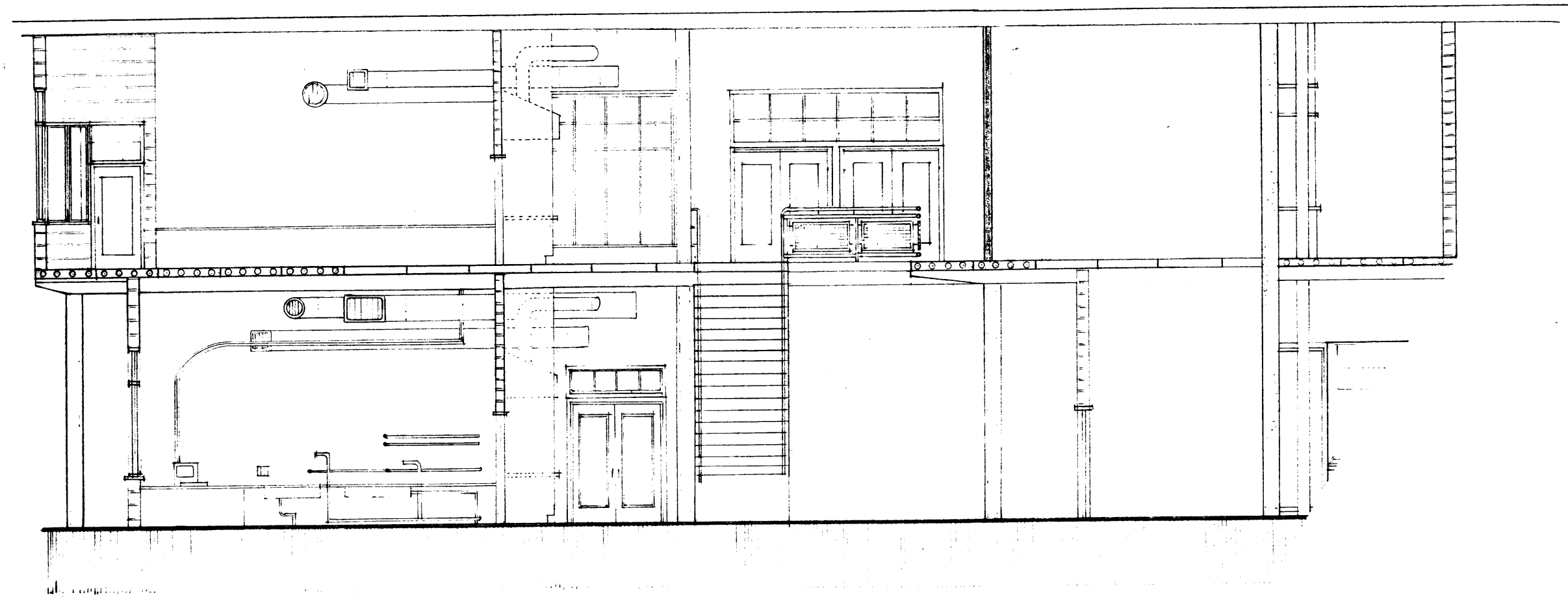

EARLY SECTION

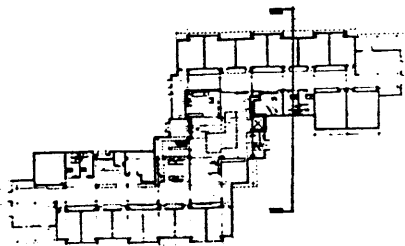
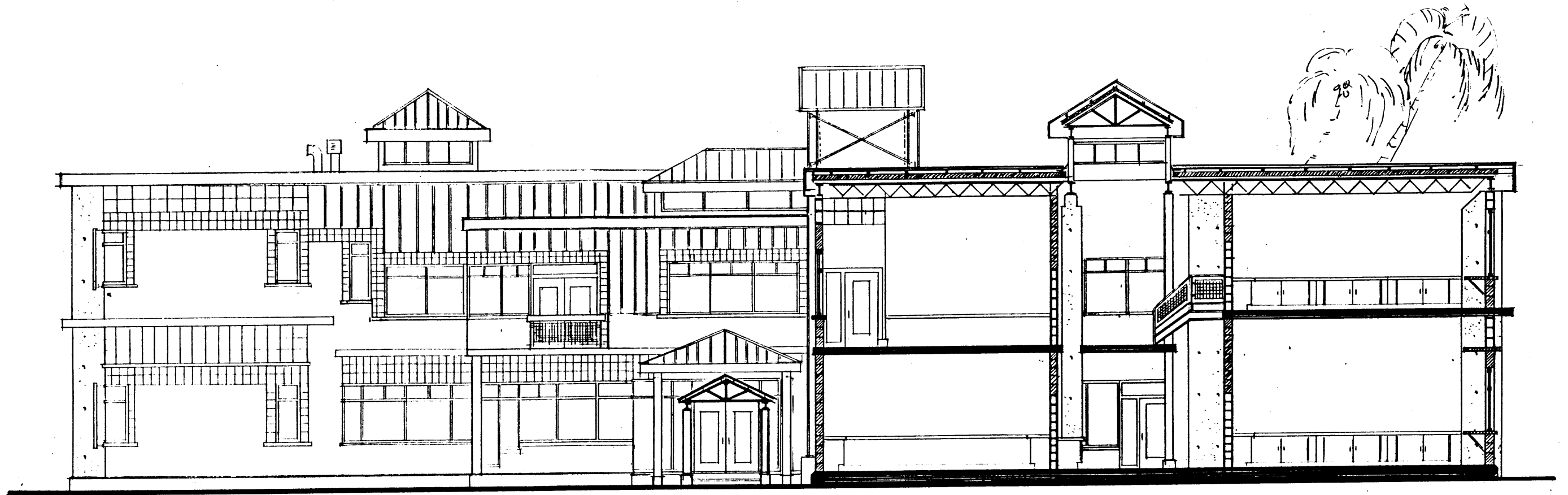

SECTION



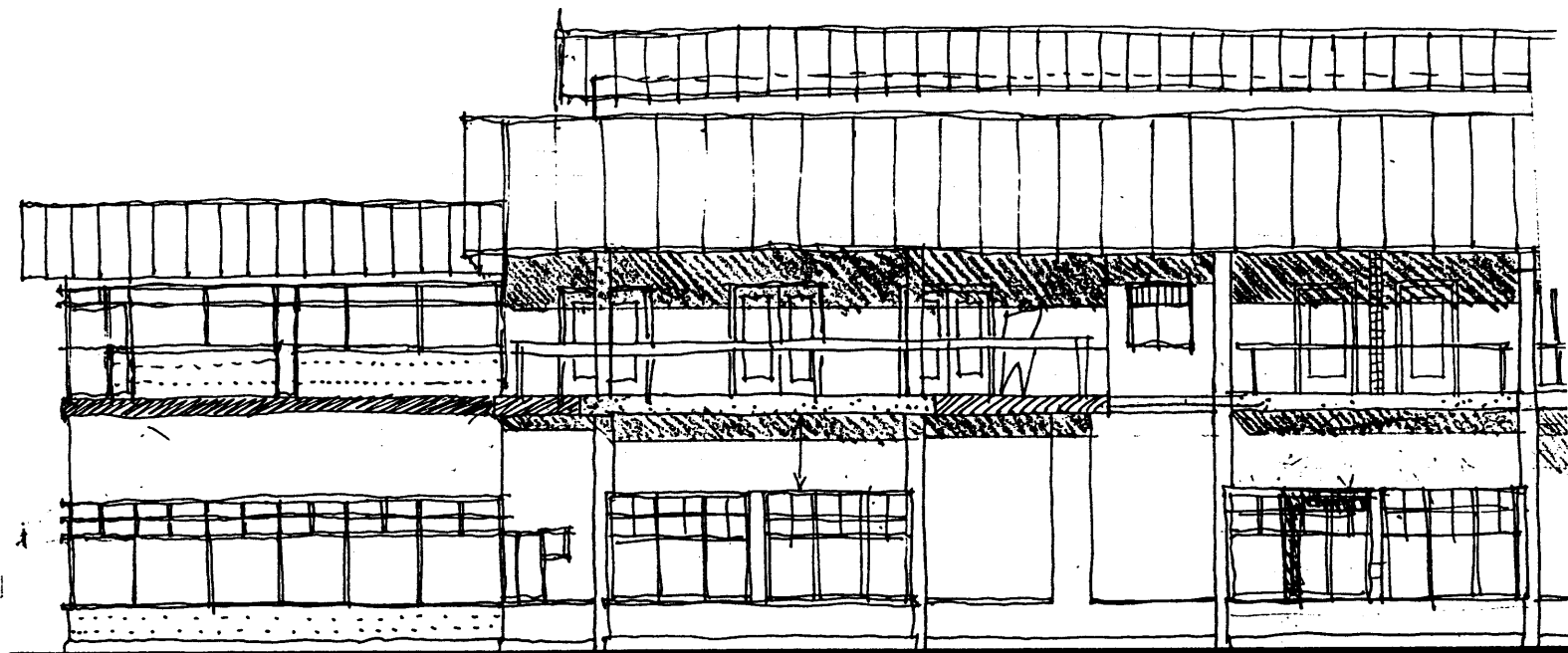

Early Elevation Study

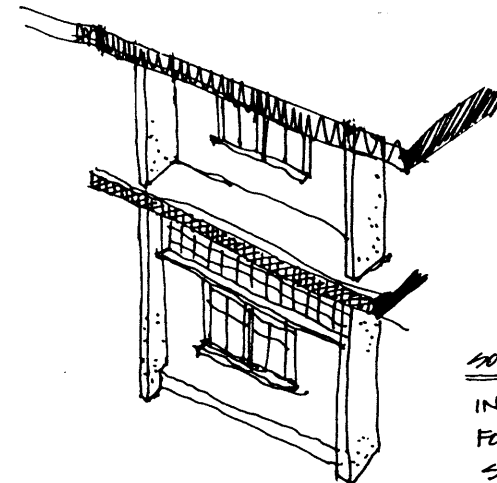

SOUTH ELEVATION
INFILL MOVES BACK AND
FORTH WITHIN PRIMARY
STRUCTURE ALTERNATELY

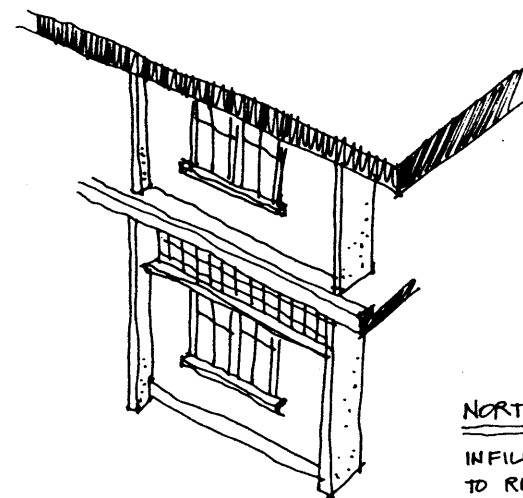

NORTH ELEVATION
INFILL MOVES FORWARD
TO RECEIVE LIGHT

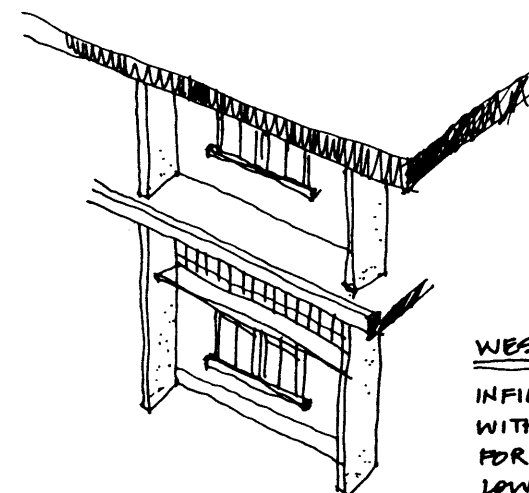

WEST ELEVATION
INFILL MOVES BACK
WITHIN PRIMARY STRUCTURE
FOR SHADING FROM
LOW SUN

Elevation Diagrams

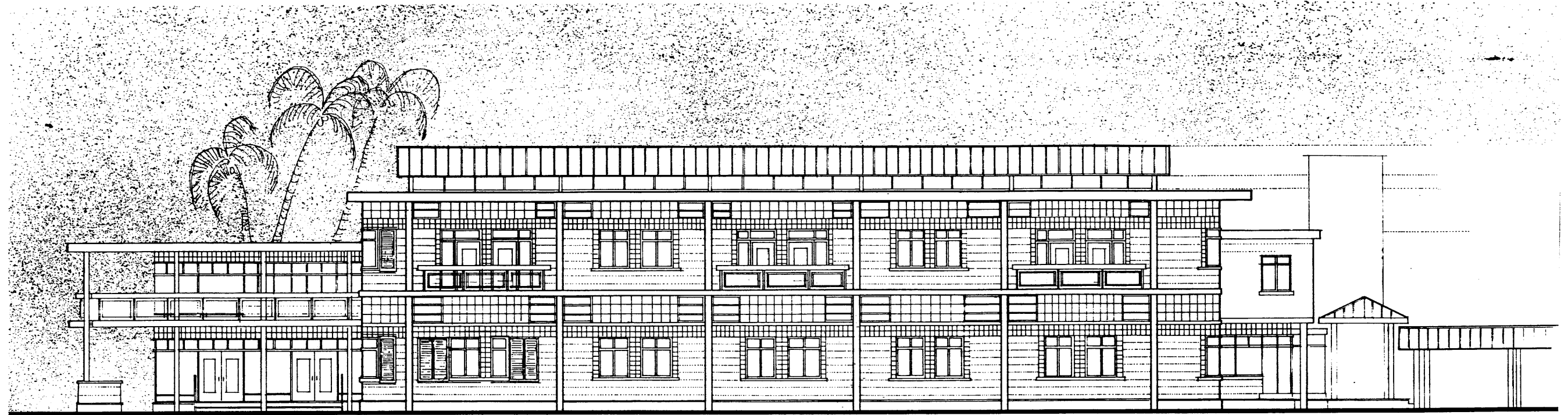

ELEVATION (SOUTH)

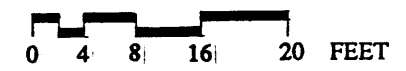

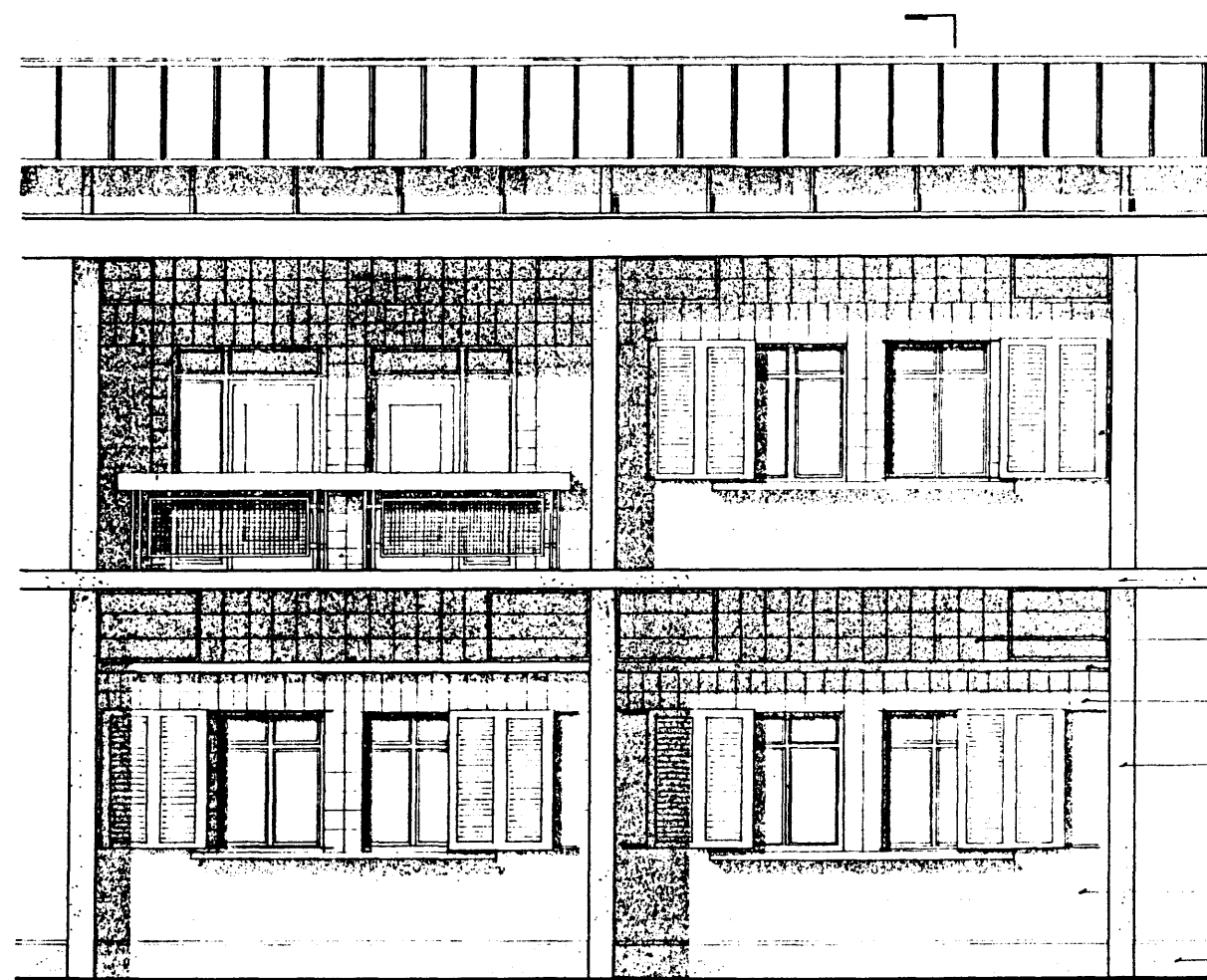

- OPERABLE SHUTTERS

FLOOR SLAB

GLASS BLOCK

LIGHT SHELF

TILES

PRIMARY STRUCTURE
(CONCRETE)

CMU

CONCRETE BASE



South Elevation Detail

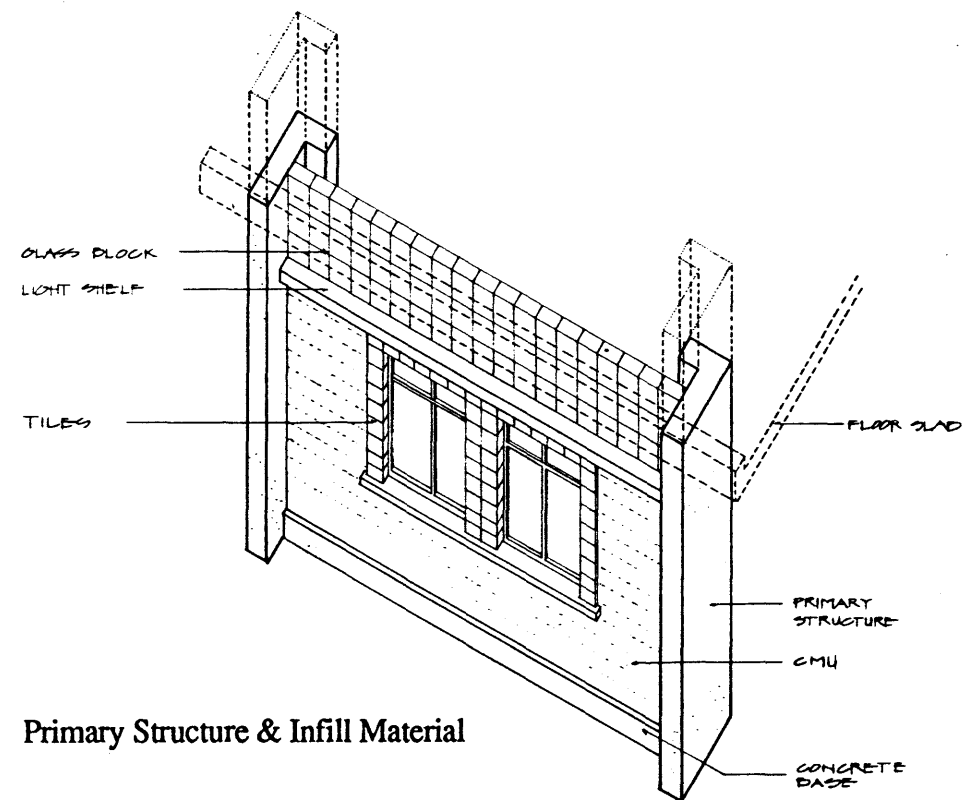

Primary Structure & Infill Material

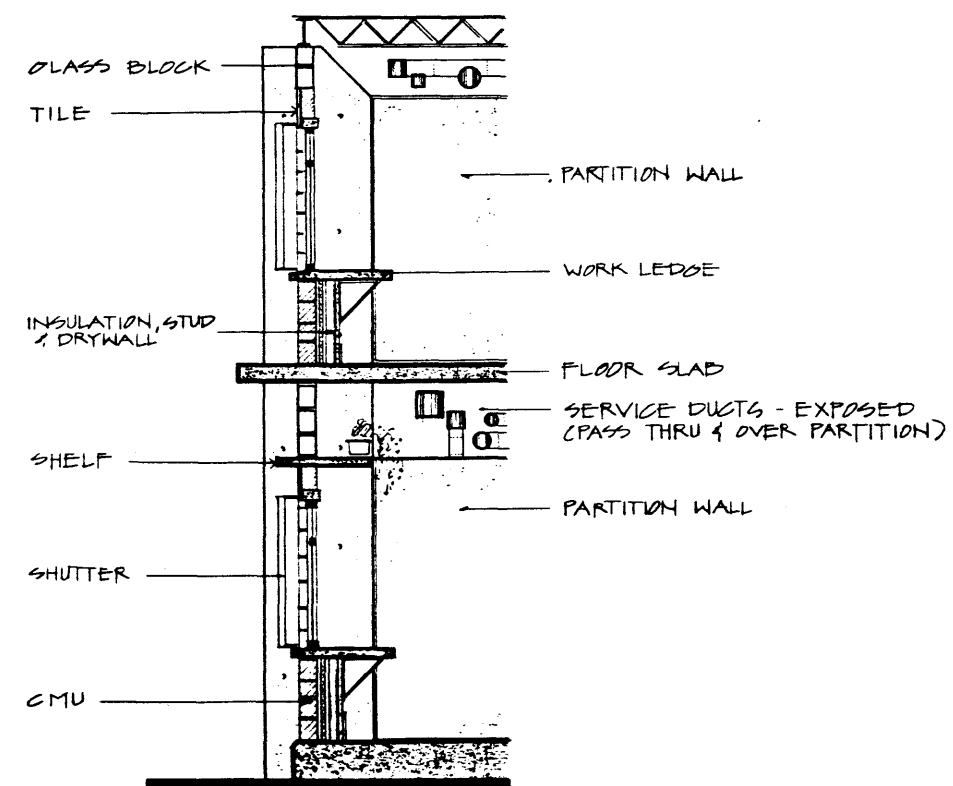

GLASS BLOCK

TILE

PARTITION WALL

WORK LEDGE

INSULATION, STUD
& DRYWALL

FLOOR SLAB

SERVICE DUCTS - EXPOSED
(PASS THRU & OVER PARTITION)

SHELF

PARTITION WALL



SHUTTER

CMU

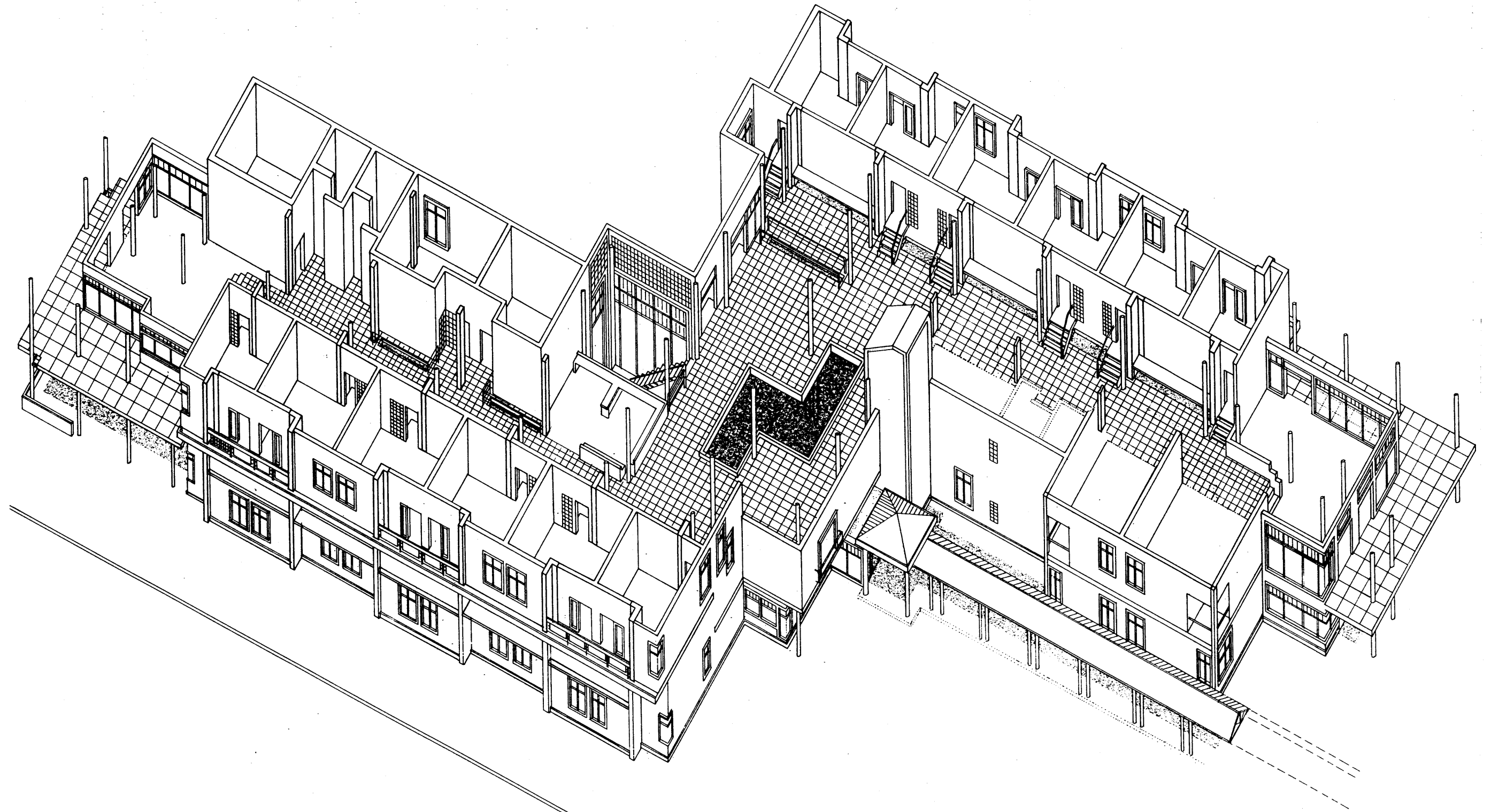
Wall Section

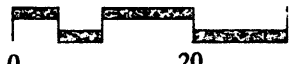

AXONOMETRIC



0 20 FEET

BIBLIOGRAPHY

Christian Norberg-Schulz; The Concept of Dwelling; on the way to figurative architecture, Rizzoli, New York, 1985.

Christian Norberg-Schulz; Genius Loci: Towards a Phenomenology of Architecture, Rizzoli, New York, 1979.

Gaston Bachelard; The Poetics of Space, Beacon Press, Boston, 1964.

Jiro Hirada; The Lesson of Japanese Architecture, Charles T. Branford Company, Boston, 1954.

Norman F. Carver; Form and Space in Japanese Architecture, Shokokusha Publishing Co., 1955.

Wohl and Frontiero; 'Thresholds: Landscape, City and Building Edges', M.Arch Thesis, MIT Department of Architecture, 1986.

Henry Plummer; 'Realm of the Landing, Reciprocal Form and Spatial Dialectics at the Threshold', Reflections: The Journal of the School of Architecture, vol. 2, no.1, University of Illinois, Urbana-Champaign, 1984.

Matthew Longo; 'Reciprocal with the Landscape', M.Arch Thesis, MIT Department of Architecture, 1985.

Marc Treib; 'Inflected Landscapes', Places, vol.1, no.2, The MIT Press, Cambridge, MA, 1984

Gary O. Robinette, Editor; Landscape Planning for Energy Conservation, Van Nostrand Reinhold Company, New York, 1983.

Teiji Ito; The Japanese Garden: An Approach to Nature, Yale University Press, New Haven, 1972.

Christopher Thacker; The History of Gardens, University of California Press, Berkeley, CA, 1979

Tadahiko Higuchi; The Visual and Spatial Structures of Landscapes, The MIT Press, Cambridge, MA, 1983.

Bring & Wayembergh; Japanese Gardens: Design and Meaning, McGraw-Hill Book Company, New York, 1981.

Donald W. Curl, Mizner's Florida, MIT Press, Cambridge, MA, 1984.

Brian B. Taylor; Geoffrey Bawa, A Mimar Book, Concept Media Ltd., Singapore, 1986.

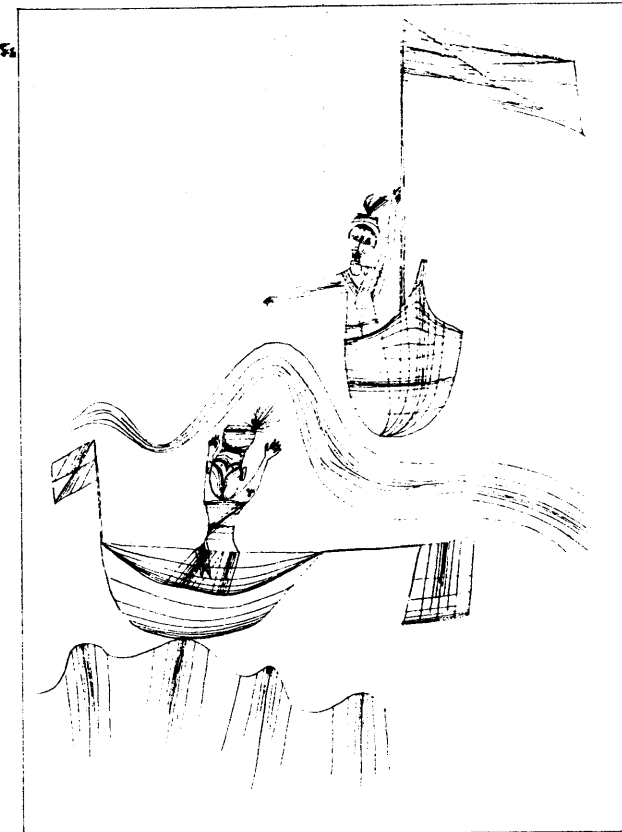

Klee

