

# IMPLICATIONS OF CONSTRUCTION TECHNIQUES ON THE PERFORMANCE OF SLURRY WALLS

by

**PHILIP MICHAEL IANNACCONE**  
B.S. Civil and Environmental Engineering  
University of California, Berkeley, 1998

*Submitted to the Department of Civil and Environmental Engineering  
In Partial Fulfillment of the Requirements for the Degree of*

MASTER OF ENGINEERING  
In Civil and Environmental Engineering  
at the  
MASSACHUSETTS INSTITUTE OF TECHNOLOGY  
June, 1999

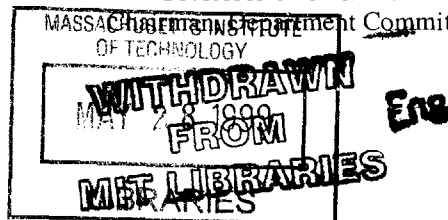
*©1999 Philip Michael Iannaccone. All rights reserved.*

*The author hereby grants to M.I.T. permission to reproduce and to distribute publicly paper  
and electronic copies of this thesis document in whole and in part.*

Signature of Author .....  
Department of Civil and Environmental Engineering  
May 17, 1999

Certified by .....  
Jerome J. Connor  
Professor of Civil and Environmental Engineering  
Thesis Supervisor

Accepted by .....  
Andrew J. Whittle  
Professor of Civil and Environmental Engineering  
Department Committee on Graduate Studies



# **IMPLICATIONS OF CONSTRUCTION TECHNIQUES ON THE PERFORMANCE OF SLURRY WALLS**

by

**PHILIP MICHAEL IANNACCONE**

*Submitted to the Department of Civil and Environmental Engineering at the  
MASSACHUSETTS INSTITUTE OF TECHNOLOGY*

*On May 17<sup>th</sup>, 1999*

*In Partial Fulfillment of the Requirements for the Degree of  
MASTER OF ENGINEERING*

*In Civil and Environmental Engineering*

## **ABSTRACT**

It is not possible to have underground structures just appear in place. The process of placing them there changes the very environment they were designed to interact with. This thesis examines the possible interactions between construction and performance of slurry walls.

The path from idea to realization of large facilities or infrastructure projects involves many stages and people. The coordination and exchange of information, concepts, and assumptions from person to person during these projects can play a critical role. Many times drawings and plans made by design engineers give little thought to the construction process or how the product will come to be. Some structures like the proposed self-anchored suspension bridge to replace the Oakland Bay Bridge are not even stable until complete. Such plans are given to contractors, who are left to fill in the blank. The "then a miracle happens" step needs to occur by some means.

Thesis Supervisor: Jerome J. Connor

Title: Professor of Civil and Environmental Engineering

# ***ACKNOWLEDGMENTS***

---

This page is reserved to pay tribute to the many people who have supported and encouraged me on the way to this milestone and all the ones previous.

I would like to thank:

Professor Connor for his effort in serving as advisor, for finding time even with his many other students, and for allowing me to take a geotechnical view of a structural problem.

Charles Helliwell for his insights and comments through out the year and time spent editing this thesis.

Lisa Grebner from Modern Continental for her valuable advice on the term project.

Stephen Taylor from Hatch Mott MacDonald for taking me to see the tallest cantilevered slurry wall ever constructed.

SigEp and the Educational Foundation grant for their generous hospitality this past year. If all living groups could be as supportive and proactive, the college community would be much stronger.

My family for their patients, enthusiasm, and moral support.

# **TABLE OF CONTENTS**

---

## **CHAPTER 1**

<b>INTRODUCTION .....</b>	<b>8</b>
1.1 UNDERGROUND WALLS .....	8
1.2 CASE HISTORIES.....	8

## **CHAPTER 2**

<b>SLURRIES .....</b>	<b>11</b>
2.1 STABILITY OF DRY EXCAVATIONS .....	11
2.2 DRILLING HISTORY .....	13
2.3 COLLOID CHEMISTRY .....	15
2.4 TYPICAL SLURRY SPECIFICATIONS.....	16

## **CHAPTER 3**

<b>CONCRETE .....</b>	<b>21</b>
3.1 COMPOSITION.....	21
3.2 REINFORCEMENT.....	22
3.3 BONDING.....	23

## **CHAPTER 4**

<b>CONSTRUCTION PROCESS .....</b>	<b>25</b>
4.1 PANEL SECTIONS AND ARRANGEMENTS.....	25
4.2 EXCAVATION.....	28
4.3 SLURRY CONTROL.....	30
4.4 PLACEMENT OF REINFORCEMENT CAGE AND CONCRETE.....	30

**CHAPTER 5**

**TROUBLESHOOTING ..... 32**

- 5.1 PROBLEMS ..... 32
- 5.2 SEDIMENTATION..... 32
- 5.3 INFILTRATION AND ALTERATION..... 33
- 5.4 CONCRETE MIXING ..... 33
- 5.5 BONDING STRESS REDUCTION..... 36

**CHAPTER 6**

**COMPARISON ..... 39**

- 6.1 REASONS FOR CONCERN ..... 39
- 6.2 STIFFNESS DESIGN FOR DEFLECTION..... 39
- 6.3 TENSION LAP SPLICE DESIGN..... 41

**CHAPTER 7**

**CONCLUSION ..... 43**

**REFERENCES ..... 45**

# **TABLE OF FIGURES**

---

FIGURE 1.1 – Plan View of the Post Office Square Garage..... 9

FIGURE 2.1 – Assumed Failure Planes Through Soil..... 12

FIGURE 2.2 – Filter Cake Formation ..... 13

FIGURE 2.3 – Caving Soil Deposits..... 14

FIGURE 2.4 – Different Particle Orientations ..... 16

FIGURE 2.5 – Marsh Funnel for Measuring Viscosity..... 17

FIGURE 2.6 – Densities of Typical Drilling Fluids..... 18

FIGURE 2.7 – Standard Filter Press Apparatus ..... 19

FIGURE 2.8 – Paper Strips for Measuring pH..... 19

FIGURE 2.9 – Calibrated Glass Measuring Tube ..... 20

FIGURE 3.1 – Rebar Designations ..... 22

FIGURE 3.2 – Free Body Diagram of Rebar ..... 23

FIGURE 4.1 – Schematic of Construction..... 25

FIGURE 4.2 – Typical Panel Sections ..... 26

FIGURE 4.3 – Sequence for Alternating Placement of Sections..... 27

FIGURE 4.4 - Sequence for Successive Placement of Sections ..... 27

FIGURE 4.5 – Operation of Clamshell Bucket ..... 28

**FIGURE 4.6 – Excavation Using a Dragline ..... 29**

**FIGURE 4.7 – Placement of Concrete Through Tremie Pipe..... 31**

**FIGURE 5.1 – Concrete Compressive Strengths..... 34**

**FIGURE 5.2 – Modulus of Elasticity..... 35**

**FIGURE 5.3 – Bond Stress Curves for Different Amounts of Bentonite ..... 37**

**FIGURE 5.4 – Bond Stress at a Slippage of 0.25 mm ..... 37**

**FIGURE 6.1 – Sketch of a Lap Splice..... 41**

# **CHAPTER 1**

---

## **INTRODUCTION**

### **1.1 Underground Walls**

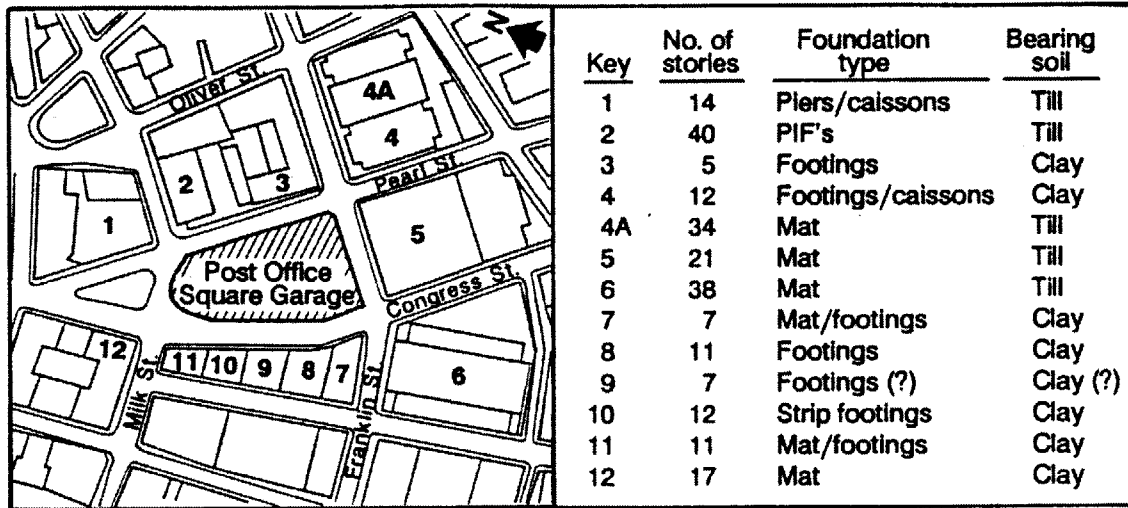
Walls define the spaces in which we live. Architects use walls and dividers to craft these spaces with the purpose of altering our mood, generating a sense of privacy, and to please our aesthetic palette. Walls below the subsurface, which rarely get seen, are no less important. Underground walls meet many needs; they are construction aids, permanent structures, and treatment barriers just to name a few. Slurry walls are a specific type of underground wall, which are constructed while the surrounding ground is held open with a dense fluid. This method of construction has accelerated projects and made nearly impossible ones feasible. Two noteworthy examples from the Boston area are the Post Office Square Garage and the Central Artery Tunnel project.

### **1.2 Case Histories**

The underground parking garage located in the financial district, on an area known to locals as Post Office Square, was designed to hold 1400 automobiles on seven below grade levels. The garage was built using an innovative sequence called top-down construction. In this method the structure is assembled from the surface down as excavation proceeds. On a more typical project the excavation would have been



completed first then the structure erected up from the bottom. Slurry walls, which were installed to a depth of 80-feet on the project site served as excavation support, braced by floor slabs, and became the permanent walls of the garage. The street level of the structure is a public park. A plan view of the project is sketched below mapping out the numerous other building around the site, which were put at risk.



**Fig 1.1** Plan View of the Post Office Square Garage (Schoenwolf, 1992)

The Central Artery Tunnel is a considerably larger project when compared to the above garage, but none the less dependant on the performance of slurry walls.

“It (slurry wall construction) is the single most important construction technique on this gigantic project, and it’s the primary tool the designers are using to help the project keep its most important promise to the people of Boston: Keeping the city open for business and traffic moving during more than a decade of construction.”

[www.bigdig.com](http://www.bigdig.com)

The lofty goal of this project is to replace the elevated highway structures built through downtown Boston in the 1950’s with a modern underground tunnel with greater traffic capacity. A series of linear parks and gardens will take the place of

the dilapidated interstate roadways, reuniting communities and neighborhoods divided decades ago. Much of the tunnel is being built as cut and cover sections through the city. The slurry walls are required to hold open these corridor excavations, support the still operational highways, and prevent damage to adjacent high-rise buildings due to movements or watertable drawdown.

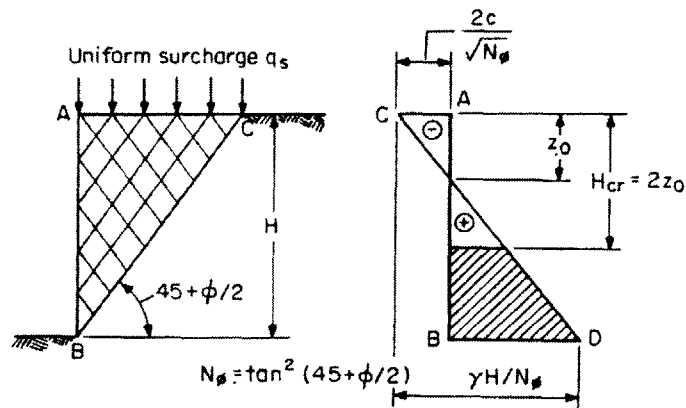
### **2.1 Stability of Dry Excavations**

Clearly these walls carry a large responsibility, but do they need to be constructed under a dense fluid? In order to demonstrate that in many cases it will be needed, one can examine the stability of a dry trench. By generalizing soil into cohesionless and cohesive families two such dry trenches will be used as examples.

A vertical cut in cohesionless soils, such as clean dry sand, simply is not stable. In fact if the face is unprotected the slope will only be stable if the angle  $\beta$  from horizontal is less than the angle of friction  $\phi$  of the material. Often the factor of safety for a slope is written as the ratio of the tangents of these angles.

$$FS = \tan(\phi)/\tan(\beta)$$

Cohesive soils such as saturated clays can support vertical cuts in the short term to a limited depth. By applying the techniques of limit theory an expression for this critical depth can be written. If a failure plane is assumed to exist at an angle of 45 degrees, the critical height will be:



**Fig 2.1** Assumed Failure Planes Through Soil (Xanthakos, 1994)

$$H_{cr} = (4c - 2q_s)/\gamma$$

$H_{cr}$  = Maximum stable depth of trench

$c$  = Cohesion factor

$q_s$  = Uniform surcharge

$\gamma$  = Unit weight of soil

(Xanthakos, 1994)

The stability at this critical depth depends on the ability of the soil to carry tensile stresses. If cracks propagate from the surface to some depth less than  $z_0$  where the soil is no longer in tension, the maximum unsupported height will be reduced.

If one reexamined the same trench after it had been filled to the surface with a fluid, and assuming that this fluid remained in the trench with out flowing into the surrounding soil, a new stability can be calculated in a similar manner. By adding a hydrostatic pressure against the face of the active wedge, the critical depth would become:

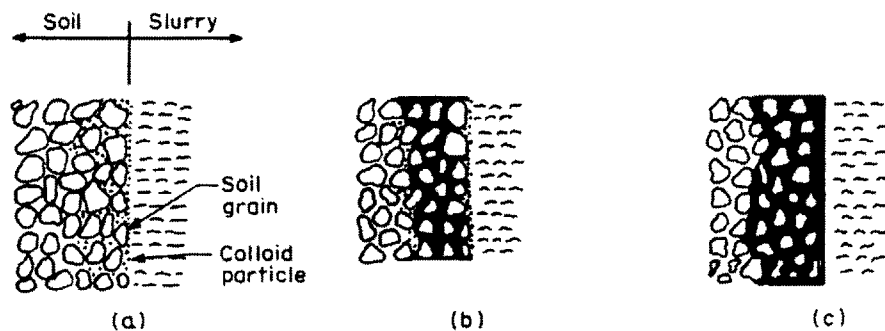
$$H_{cr} = (4c - 2q_s)/(\gamma - \gamma_f)$$

Where  $\gamma_f$  is the density of the slurry. Clearly as the density of the fluid increases and approaches that of the soil removed from the trench the maximum depth also increases. (Xanthakos, 1994)

## 2.2 Drilling History

The need for slurries first became apparent in the drilling industry. In the oil trade as in many other types of business, time is money, and anything that could accelerate a process directly impacts the bottom line. At some time between 1887 and 1901 when drilling fluids first became standard practice, they “had a greater effect on rate of penetration than any of the other controllable variables in the rotary drilling process.” (Chilingarian, 1983) The beginning of this time period is marked by the award of a United States patent to Chapman in 1887 for the use of clay, grain, and cement suspensions to create a lining within the borehole.

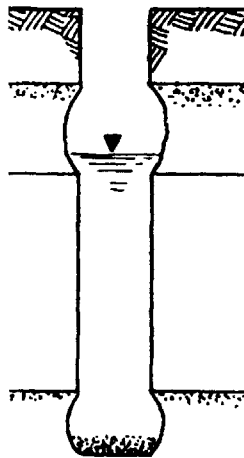
The formation of this lining allows the slurry to apply a hydrostatic fluid pressure to the interface and prevent any further loss of slurry. The zone of soil lining the face, which is transformed into the barrier, is referred to as the filter cake. The process by which the filter cake is formed is depicted below.



**Fig 2.2** Filter Cake Formation (Xanthakos, 1994)

Slide (a) shows the initial infiltration of the slurry suspension into a granular soil due to a pressure gradient and electrokinetic forces. The colloid particles will deposit within the void spaces as seen in slide (b). The accumulation of particles will act as a filter causing more and more clay or other suspended material to be deposited. As this process continues the voids become packed with solid material and the permeability drops until a seal is completed along the cut surface. This completed filter cake is shown in the last slide. (Xanthakos, 1994)

The use of these types of slurries did not become popularized until 1901 with the extremely successful Lucas well in Spindletop, Texas. This well produced about 80,000 bbl of oil per day, but was almost never completed. Captain Anthony F. Lucas originally abandoned a well at the location due to difficulties proceeding through soft formations which tended to cave and collapse in a manner similar to the one depicted below.



**Fig 2.3** Caving Soil Deposits (Xanthakos, 1994)

Another drilling attempt was made with the help of the Hamill brothers. This time clay slurry was used to seal the wall of the borehole. The drilling slurry was mixed by leading a herd of cattle through a surface pit dug in clay. For many years after

prospectors continued to manufacture the slurry in a similar manner hoping to have the success of Lucas's well. (Chilingarian, 1983)

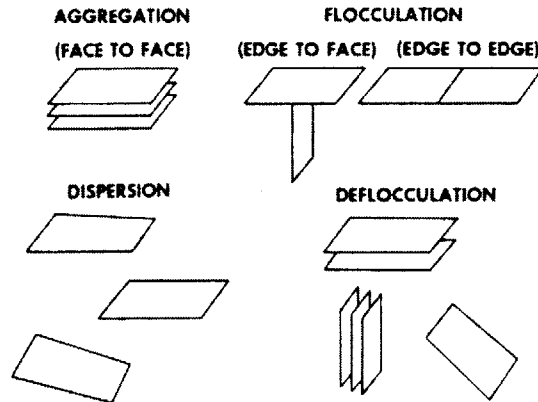
### **2.3 Colloid Chemistry**

Clay particles differ from sand grains in that they have considerably larger specific surface area. That is to say that for a given amount of mass there is a greater amount of surface area. This property of clay particles makes them more susceptible to chemical and electrical effects. The difference in SSA is due to the difference in size and shape of the particles. Sand grains are larger spherical particles while clay minerals are smaller platy shaped particles. Clay particles while considerably larger than atoms or simple molecules are still much too small to see with the human eye alone. Particles of this size,  $10^{-7}$  to  $10^{-3}$  cm, are classified as colloids. Colloids differ from other particles in that their behavior is influenced more strongly by surface forces, than with mass related forces. When colloid sized particles are mixed with water they form suspensions. The microscopic particles in these mixtures undergo Brownian motion, a perpetual random movement caused by irregular collisions with molecules in the surrounding fluid.

Bentonite, which is added to water to make most slurries, is a clay composed of montmorillonite. These particles are typically 1000 angstroms by only 10 angstroms thick which gives the clay an extraordinary specific surface area of approximately 800 m<sup>2</sup>/gram. Water can be adsorbed to this surface area until individual crystal sheets are separated. The volume of adsorbed water often called the double layer is essentially trapped around the clay to balance out any charge. Clay particles possess negative surface charges which would be balanced by the presence of ions. If water is made available to these ions the water will hydrate the ions along with the surface of the clay particle. (Lambe, 1969)

Any physicochemical effects such as a change in pH or salt concentration will affect the manner in which the double layer balances surface charge and in turn impact

the properties of the clay. One such behavioral change, which is of particular importance for slurries, is flocculation.



**Fig 2.4** Different Particle Orientations (Chilingarian, 1983)

Flocculation is a state of particle orientation in which clusters of particles exist. Such clusters form when double layers reduce to a point when close range attractive forces are able to hold particles together. Because of this phenomenon and others, it is crucial to plan and control the chemistry of all slurries used through detailed specifications.

## **2.4 Typical Slurry Specifications**

Slurries have advanced quite a bit from the time of Chapman's patent and driving cattle in and out of surface pits. In order to engineer the optimum slurry for wall construction a number of properties are generally specified.



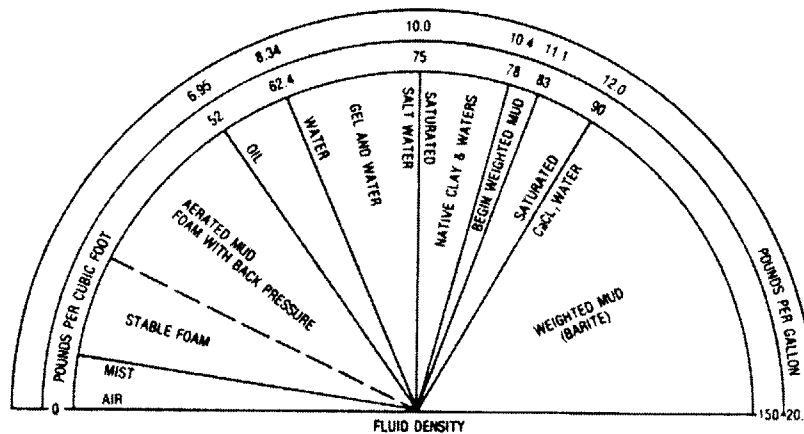
Viscosity, the ability to resist shear stress, can both aid and impede the construction of slurry walls. On one hand, fluid slurry is needed for easy of pumping, while on the other hand thick slurry is desirable to suspend cuttings and prevent accumulation of sediment at the base of the trench. Viscosity of slurry is dependent on the percentage of bentonite present and the amount of agitation applied to the slurry. Bentonite slurry is thixotropic, it has the reversible property of easy flow while being mixed and a gel behavior after being left at rest. The viscosity can be measured by the use of a Marsh funnel as described in the American Petroleum Institute's specification 13A and RP 13B.(Millet, 1992) For this test the viscosity is recorded as the amount of time required for a quart of slurry to flow out of a funnel, such as the one seen below.(Reese, 1985) A viscosity of 40 Marsh seconds has been stated as a suitable value for the construction of slurry walls.(Millet, 1992)



**Fig 2.5** Marsh Funnel for Measuring Viscosity (Chilingarian, 1983)

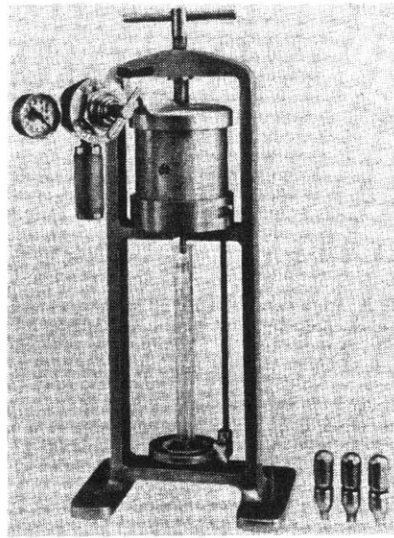
Density is another property in which tradeoffs need to be judged. The greater the unit weight of the slurry, the greater the increase in stability for the excavated

trench. However as the unit weight approaches that of the concrete to be placed the tremie process will be hindered. A chart displaying various types of slurries and their densities is located below. Bentonite slurries used for construction of underground walls typically fall in the range between 65 lb/ft<sup>3</sup> and 75 lb/ft<sup>3</sup>.



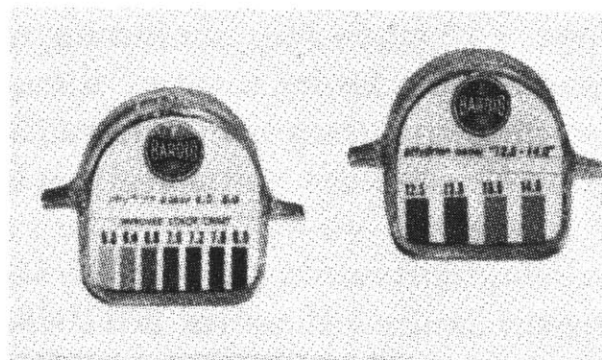
**Fig 2.6** Densities of Typical Drilling Fluids (Chilingarian, 1983)

Filtrate loss not only gives insight into the amount of fluid required at the construction site but also indirectly is a measure of trench stability. Filtrate loss is controlled by the thickness and by the rate of filter cake formation. This will play a critical role in repairing and reformation of filter cake after abrasion from excavation equipment. Filtrate loss can be measured by a standard filter press test as described by API Test PP131B. The apparatus for running such a test is shown in the photograph on the top of the following page. Typical values yielded from this test on bentonite slurries are 15 cm<sup>3</sup> to 30 cm<sup>3</sup>.(Millet, 1992)



**Fig 2.7** Standard Filter Press Apparatus (Chilingarian, 1983)

The pH of the slurry, which can easily be influenced by the surrounding environment, has a large effect on the behavior of clay particles. For this reason the pH should be monitored regularly using pH paper, shown below, or an electric meter. Ideally the pH should remain in a range of 6.5 to 10. If allowed to become too basic the particles will flocculate and fall out of suspension.(Millet, 1992)



**Fig 2.8** Paper Strips for Measuring pH (Chilingarian, 1983)

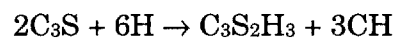
Sand content in the slurry is used as an indicator for the degree of contamination. The amount of sand or any cuttings trapped in the slurry for that matter should be kept to a minimum prior to pouring the concrete. If detritus is present, it may interfere with the flow of concrete or become mixed in with the concrete. Sand content can be measured by passing a standardized volume of slurry through a no. 200 screen and recording the amount of material remaining on the sieve. A special calibrated cup for measuring sand volume is seen below.(Reese, 1985)



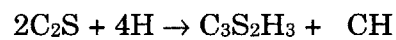
**Fig 2.9** Calibrated Glass Measuring Tube (Chilingarian, 1983)

### **3.1 Composition**

Concrete is a conglomerate of different materials. Fundamentally these materials are rock or other hard fragments called aggregate which are embedded in a binding agent. Aggregate is generally subdivided into coarse aggregate, or gravel, which are particles that will not pass through a No.4 sieve, and the smaller fine aggregate, or sand. The binding agent is the product of chemical reactions between cement and water. Cements are finely crushed calcium silicate minerals. The basic form of this hydration reaction is written below.



or



Where: C = CaO

S = SiO<sub>2</sub>

H = H<sub>2</sub>O

(Mehta, 1993)

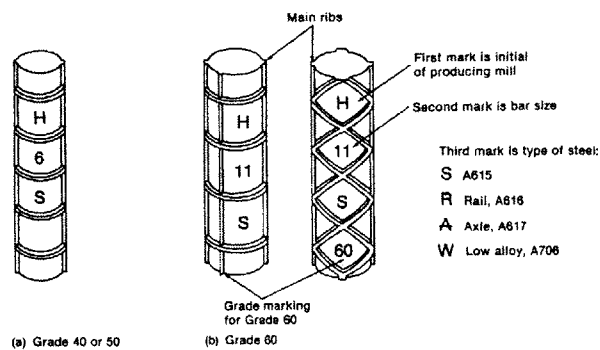
Very often admixtures are also included in concrete. Any compound other than cement, water, or aggregate is classified as an admixture. Some common

admixtures include fly-ash and organic surfactants. They are added to improve the workability, resistance to certain chemical attacks, or adjust the rate of hydration among other things.

### 3.2 Reinforcement

As a material, concrete is excellent for handling compressive stresses. However, its brittle nature prevents it from carrying significant tension. Steel on the other hand behaves wonderfully in tension. Reinforcement is generally made of steel tendons placed within the concrete mass in the locations of expected tensile stresses. These reinforcing bars are commonly abbreviated as rebars. With this design engineers can create a composite building material with the low cost and freedom of shape which concrete provides with out sacrificing the ability to withstand tension. It is not a new idea. Straw has been added to mud bricks for thousands for years for the very same reasons.

Depending on the capacity desired to be carried by the steel within the concrete mass, varying amounts and different sizes of rebar can be specified. Bars are given numbers based on their diameter. The number is equal to the eighths of an inch in the diameter. A No.5 bar has a diameter of  $5/8^{\text{th}}$  in.

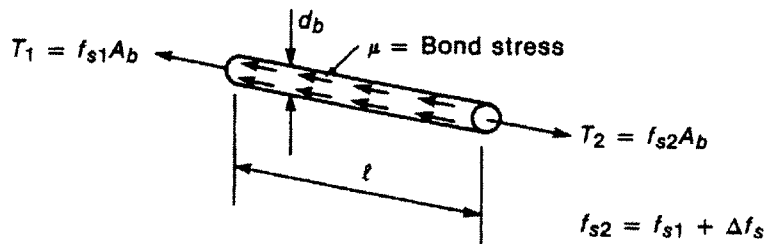


**Fig 3.1** Rebar Designations (MacGregor, 1997)

Due to site, equipment, transportation, and manufacturing constraints a maximum bar length exists. One often finds this length to be 60 feet.(Xanthakos, 1994) As a result of this limitation splices often become a necessity when constructing reinforced concrete structures. The development and transfer of tensile stress from one bar to another in splices, where a direct mechanical connector is not used, is dependent on the bonding between the steel and concrete.

### 3.3 Bonding

With the exception of inertial and self-weight forces, all loads are applied the surface of the concrete mass as opposed to the steel reinforcement. Yet the steel is designed to carry the tensile stresses; this requires a transfer of load from the concrete to the reinforcement through a bond. It is possible to find an expression for the average bond stress developed by representing a segment of a bar by the free-body diagram presented in fig 3.2.



**Fig 3.2** Free Body Diagram of Rebar (MacGregor, 1997)

By stating that the bar is in static equilibrium a force balance can be undertaken to relate the average bond stress to the stresses observed at either end of the segment.

$$\Sigma F = 0$$

$$\Delta f_s \pi (d_b)^2/4 = \mu_{avg} (\pi d_b) l$$

and  $\therefore$

$$\mu_{avg} = \Delta f_s d_b/4l$$

Where:  $\Delta f_s$  = The difference of the two bar end stresses

$d_b$  = diameter of the bar

$\mu_{avg}$  = average bond stress over the segment

$l$  = length of the bar segment

(MacGregor, 1997)

Proper design of reinforced concrete sections will maximize the capacity of a section and protect against a rapid failure. This is accomplished by limiting the amount of steel placed so that it will yield just before the concrete reaches its compressive strength. Yielding of the reinforcement leads to a ductile failure as opposed to a rapid failure with concrete crushing or steel pull out.

Clearly bonding plays an important role in this performance. Enough length must be supplied to fully develop a stress to yield the bar. From the above equation for the average bond stress one can set  $\Delta f_s$  equal  $f_y$ , the yield stress. Starting from the end of the bar, the bond stress is summed over the surface area for the length required to reach the yield stress of the steel, this distance is the development length.

$$l_d = f_y d_b/4\mu$$



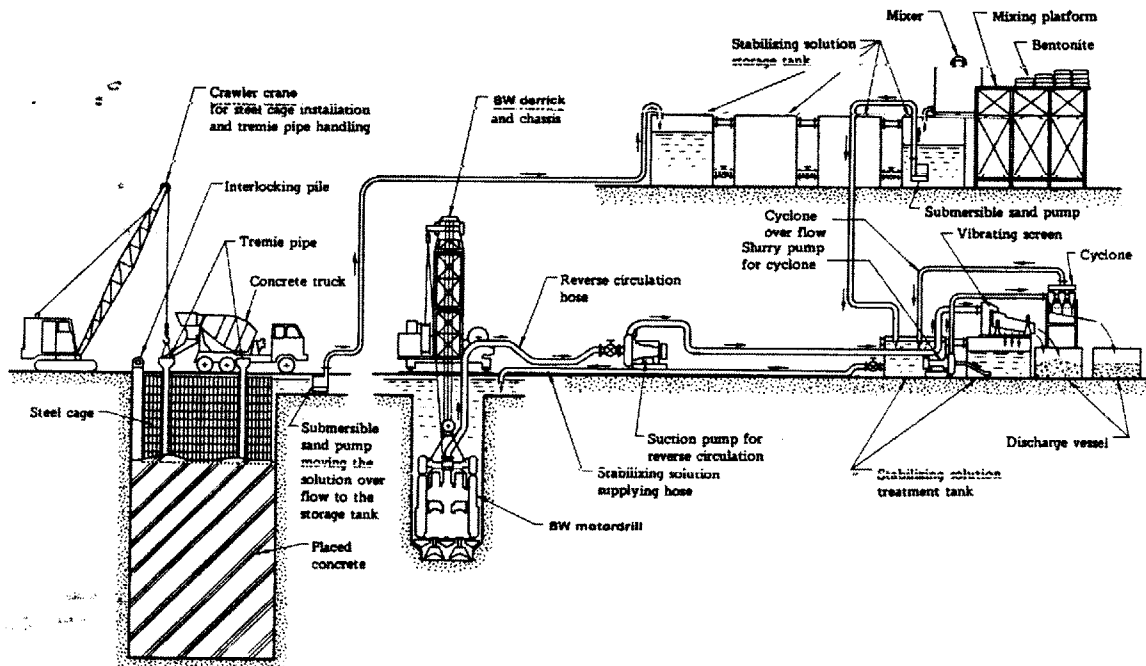
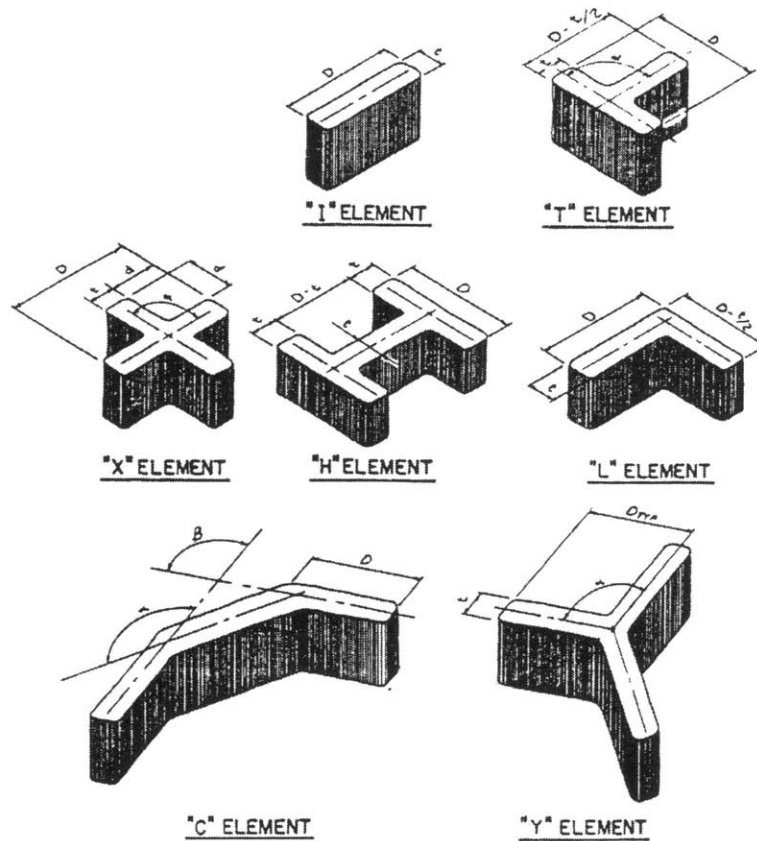


Fig 4.1 Schematic of Construction (Xanthakos, 1994)

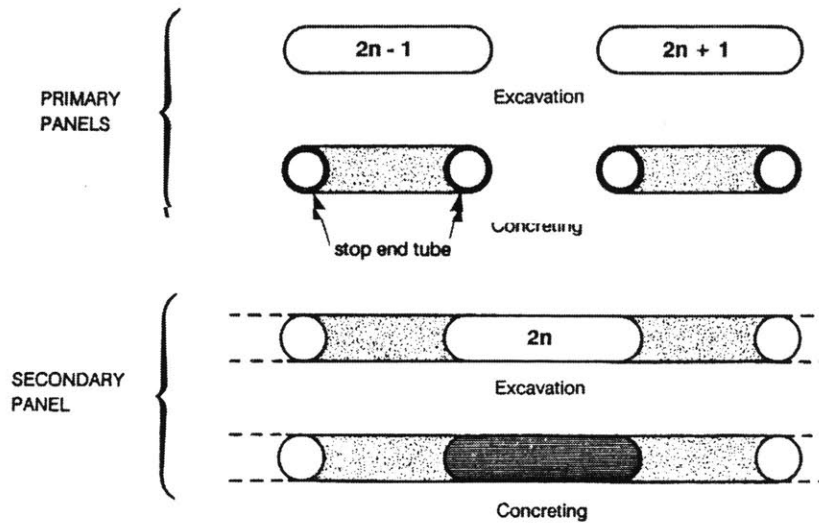
### 4.1 Panel Sections and Arrangements

Slurry walls when used to hold back the tremendous weight of earth, can be subjected to great bending moments. In order to take advantage of the versatility provided by concrete, to flow and fill complex volumes, a variety of different sections can be constructed. This allows one to create different wall shapes and required rigidity. Some of the more common section shapes are shown on the next page. However, one is really only limited by the capabilities of the excavation equipment.

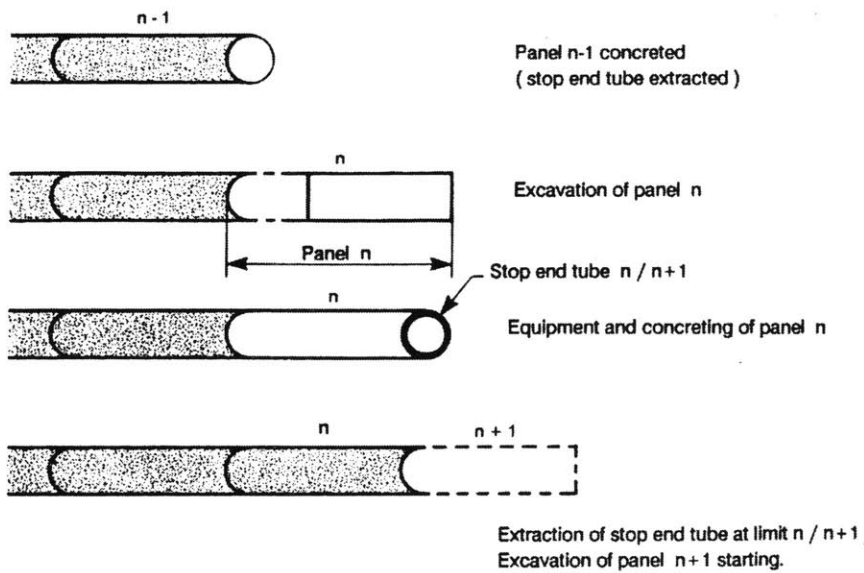


**Fig 4.2** Typical Panel Sections (Tamaro, 1992)

Working on panels a few at a time is safer than having the entire trench open at one time. Another reason for using panels as opposed to continuous trenching is to allow all of the trades to work simultaneously. Earlier stages of construction will be performed at the front of the construction progression, followed by the later stages. These panels can be placed in an alternating or successive order. The two typical sequences are depicted on the following page.



**Fig 4.3** Sequence for Alternating Placement of Sections (Vanel, 1992)

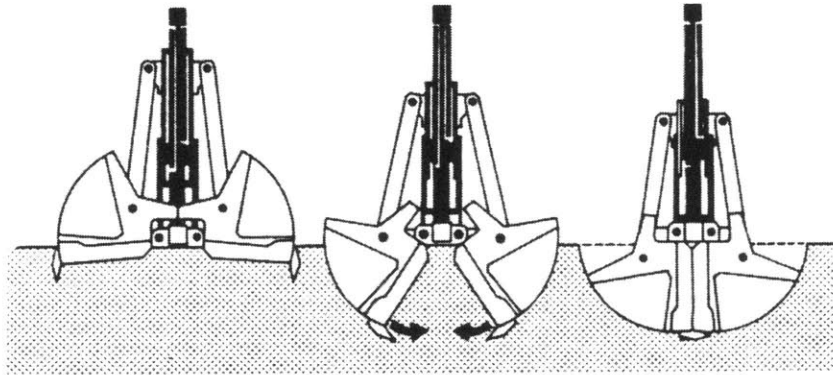


**Fig 4.4** Sequence for Successive Placement of Sections (Vanel, 1992)

## 4.2 Excavation

Excavation proceeds to the desired depth with the aid of guide walls. Guide walls are temporary walls built at grade or to a shallow depth with the purpose of restricting the machinery performing the excavation from deviating off the planed alignment. Some of the more common types of excavation equipment are described in the following paragraphs.

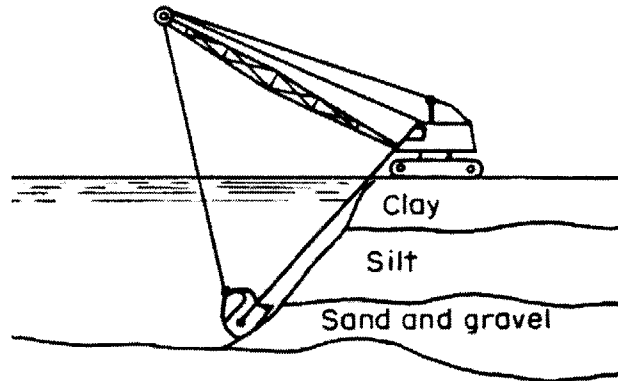
Clamshell buckets use their hydraulic powered clamps to grab and hoist up semi-circular chunks of soil from the excavation. The buckets themselves are very heavy to overcome the drag and buoyancy associated with the slurry, and curved to carve rounded ends at the joints.



**Fig 4.5** Operation of Clamshell Bucket (Hajnal, 1984)

Backhoes seen on many construction sites for placement of utilities consist of a bucket attached to the end of an articulated arm. This equipment is readily available; however, depth is limited by the reach of the backhoe arm.

Dragline and saw operations inch their way along the alignment of the trench removing material along a slope via a belt-driven system.



**Fig 4.6** Excavation Using a Dragline (Xanthakos, 1979)

Chisels and percussion type tools strike rock or hard ground to chip away or loosen material that other equipment would have difficulty with. This type of work is slower and more costly than excavation through other soils. Cuttings are removed from the trench via circulation of the slurry.

Milling or rotary-type equipment advance down into the soil by scraping away material with spinning teeth. Many of these machines pull the cuttings up within the slurry suspension through the drilling stem.

The decision of which excavator or combination of machines to be used on a project is based on a number of factors. The equipment with the lowest cost of operation that can meet the required tolerances, excavation rates, and handle the soil present will be chosen. Possible obstructions such as boulders or utilities will also influence the decision. Clearly an accurate and thorough site analyses will help in the decision.

### **4.3 Slurry Control**

Many of the excavating machines described in the previous section either deliver or remove slurry to the trench to facilitate cutting rate. For example some drilling equipment pulls slurry along with excavated material up the drill stem while others use a slurry injection to jet away soil. In any event contaminated slurry pumped from the trench is passed through a vibrating screen to remove the larger rocks and clumps of soil. The remaining discharge moves to the cyclone for the removal of finer particles before it is delivered to storage tanks. Fresh slurry is supplied to the trench as needed from this tank.

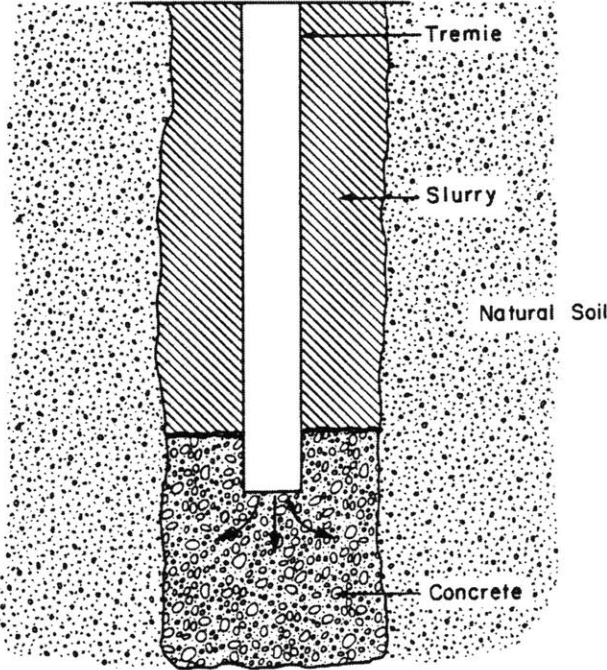
The size of hoses and power of pumps used for the collection, circulation, and cleaning of the slurry must be able to accommodate the density and viscosity of the fluid, along with any debris and total volume of slurry required.

### **4.4 Placement of Reinforcement Cage and Concrete**

Reinforcement cages if set into the trench would penetrate into the base of the excavation under their own weight, for this reason they are suspended by a crane. The cage is released once the surrounding concrete has had a chance to setup and support the rebar. Care must be taken however to ensure that any deformations due to suspending the cage from the pick points will not deflect the bars out of their original design tolerances.

Once everything is in place the concrete can be poured using a tremie process. In this method the concrete is pumped or allowed to flow under its own weight through a pipe passing through the slurry to the bottom of the trench. From there the concrete will flow outwards filling the trench. As this proceeds the pipe is raised at a rate slow enough to maintain a slight amount of embedment within the fresh concrete. The slurry will be displaced upward by the difference in densities. To

ensure a smooth displacement process a density ratio between concrete and slurry of at least 1.7 should be used. (Xanthakos, 1994)



**Fig 4.7** Placement of Concrete Through Tremie Pipe (Reese, 1985)

## **CHAPTER 5**

---

## **TROUBLESHOOTING**

### **5.1 Problems**

Some concerns in building slurry walls have been pointed out in earlier chapters. This chapter is devoted to problems worthy of further investigation. Four such problems will be investigated.

### **5.2 Sedimentation**

As seen from the previous chapter there are many types of different excavators. These machines will produce different surface characteristics at the bottom of the trench. It has been found that in theory, as long as the plan area remains the same, the shape of the base is independent of the wall's bearing capacity. In practice however a more erratically contoured base may be more difficult to clean. During the excavation process cuttings and other materials will fall out of the slurry suspension and collect at the base. Concrete placed by the tremie process, more than likely, will not push through these soft sediments. As a result such walls can settle to an extent that may jeopardize the project.

To protect against such a failure, the base of the excavation needs to be cleaned before concrete is placed. Pressurized air is blown across the base to kick-up the



sediment back into the slurry or it is vacuumed up with a hose to the slurry circulation system. Hopefully this will leave only the firm bearing layer that the concrete was designed to make contact with.

### **5.3 Infiltration and Alteration**

Before slurry walls are built, or even designed, a site investigation is performed to determine the engineering properties of the surrounding soils that will have an influence on the desired construction. The usefulness of bentonite slurries in underground construction is the transformation of the cut face soils into the filter cake material. Unfortunately as a side effect the soil which is closest and eventually in contact with the slurry wall now has considerably different properties from those used to design the wall. Will these altered properties hinder the performance of the slurry wall?

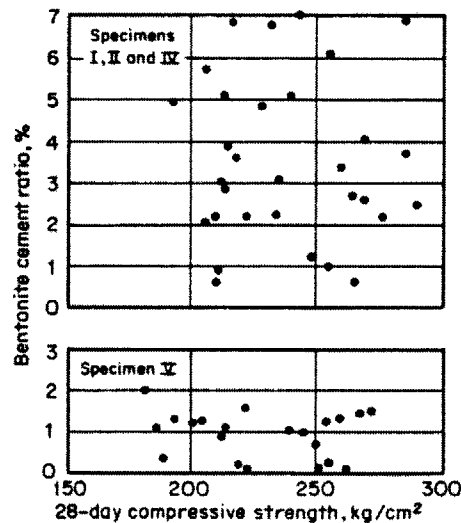
One such property of particular importance is the shear strength. A reduction of the interface shear capacity would lead to an over estimation of skin friction generated by the soil-wall contact. Similar concerns have been raised for drilled piers constructed under slurry and a number of investigations have been performed. Tests run in the laboratory have shown as much as 20% to 30% reductions of interface friction. More relevant field load tests of real sections, however, have not shown any reduction. Upon recovery of the tested piers it was observed that a significant amount of soil was found clinging to the sides of the pier, implying a failure surface outside the zone of filter cake infiltration. (Reese, 1985)

### **5.4 Concrete Mixing**

The flow of fluid is a complicated and difficult to control behavior. Due to turbulence, improper concrete consistence, or any number of other poor construction practices, a mixing of the slurry into the concrete will occur. Aside from the obvious

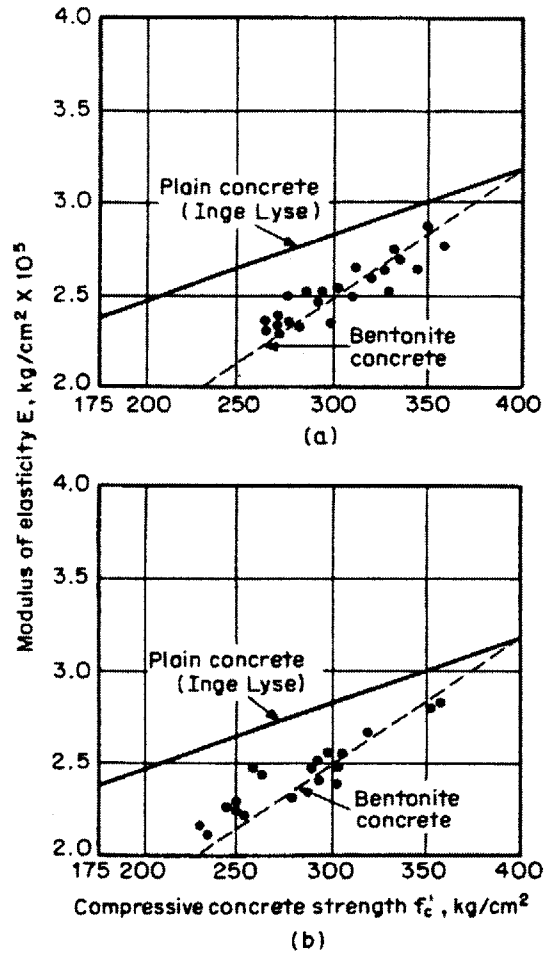
problem with formation of large-scale pockets due to cuttings or other material becoming enveloped within the concrete, are there concerns with the quality of the concrete? The presence of the inevitable minor amount of bentonite in the concrete will cause a deviation from the anticipated behavior.

Increases in the water-cement ratio, which may occur under the slurry, will lower the strength, however, the water-cement ratio for a concrete mix under slurry should never be specified for strength but rather for flowability. This is especially true for slurry construction where the use of vibrators and compactors is difficult. The ability to flow easily and fill in and around rebar, blockouts, and corners greatly outweighs the benefits of higher strength. The actual addition of bentonite to concrete by mixing with slurry has not distinguished a trend in compressive strength in either direction, as seen by the data below. Favorable curing conditions with in the damp ground may have compensated for some of the reducing factors.



**Fig 5.1** Concrete Compressive Strengths for Different Amounts of Bentonite  
Data from Ikuta et al. (Xanthakos, 1994)

The modulus of elasticity on the other hand has displayed a clear reduction with the presence of bentonite. So for the same strength which is independent of bentonite as seen earlier a different modulus will exist.



**Fig 5.2** Modulus of Elasticity for Different Compressive Strengths

Data from Ikuta et al. (Xanthakos, 1994)

In many situations only the strength of the concrete will be specified in construction documents. From this strength the design engineer may use a formula based on strength similar to the ones on the following page to estimate the modulus of elasticity.

$$E_c = w_c^{1.5} 33f_c'^{0.5}$$

or

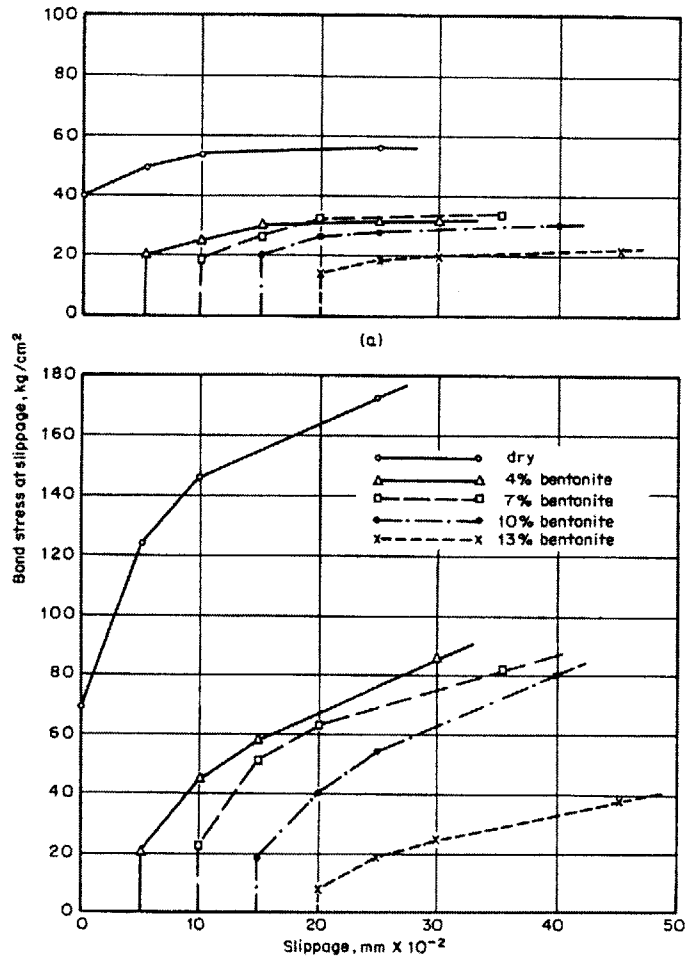
$$E_c = 57,000 \sqrt{f_c'}$$

(Metha,1993)

For the purposes of slurry wall design this equation will give a non-conservative value. The modulus of elasticity, an input parameter for finite element models and pre-solved elastic solutions will be too high. Walls designed in this manor may not have the required rigidity to prevent excessive deflections. Movement is critical because if the wall moves the active wedge of soil behind wall also moves, undermining adjacent structures or snapping fragile utility lines.

### **5.5 Bonding Stress Reduction**

Bentonite aside from being used to make slurries is popular as a cheap lubricant. As explained in previous sections during the tremie process the upward movement of concrete is supposed to expel slurry from the top of the trench. However, bentonite or other contaminants may cling to or become trapped under bars and splices, preventing the fresh mix from making full contact. The extent, by which this lubricant coating will prevent adhesion and friction, can be determined from pullout tests. Presented on the next page are data taken from the Japanese Concrete Journal. There is a marked decrease in bond stress development for the bars cast under slurry with increasing concentrations of bentonite.



**Fig 5.3** Bond Stress Curves for Different Amounts of Bentonite  
 Top Graph for Plain Bars and Bottom for Deformed Bars (Xanthakos, 1994)

Concrete sample	$u$	
	Deformed bars	Round plain bars, kg/cm <sup>2</sup>
Dry	$0.35f'_c - 0.50f'_c$	45-55
Bentonite, 4%	$0.17f'_c - 0.20f'_c$	21-22
7%	$0.13f'_c - 0.18f'_c$	16-43
10%	$0.09f'_c - 0.19f'_c$	20-33
13%	$0.07f'_c - 0.18f'_c$	11-18

**Fig 5.4** Bond Stress at a Slippage of 0.25mm (Xanthakos, 1994)

It should also be noted that bonding conditions become even worse at the higher elevations of the walls. The more volume of concrete beneath a bar, the larger amount of bleeding water will passing having a chance to accumulate around the bar.

## **CHAPTER 6**

---

## **COMPARISON**

### **6.1 Reasons for Concern**

Assuming an idealized placement with out the influence of construction is a dangerous design practice. From the descriptions of problems and data presented in chapter five some design comparisons will be undertaken. The purpose of the comparisons is to gage the sensitivity of changed properties and determine if there is a need for concern.

### **6.2 Stiffness Design for Deflection**

For simplicity, a unit length of a slurry wall will be represented as a cantilevered beam with a uniform lateral soil-load equal to  $q_0$ . This soil pressure will be assumed to equal:

$$q_0 = 0.4 \gamma L$$

Using an elastic solution to solve for the deflections along the length of the beam, an expression can be written for the maximum displacement, which will occur at the top of the wall.

$$v = (q_0/24EI)(x^4 - 4L^3x + 3L^4)$$

$$v_{\max} = q_0L^4/8EI$$

(Popov, 1990)

If the wall's geometry is described by a thickness of 30-inches and a height of 20-feet with a rectangular cross section, the bending moment of inertia for a unit length can be written as:

$$I = bh^3/12$$

From the data presented in section 5.4 the modulus of elasticity can be determined given the compressive strength. For the purpose of the example lets say a compressive strength of 4000 psi had been specified. For normal construction a value of  $5.7 \times 10^8$  lbs/ft<sup>2</sup> would be appropriate, but for slurry construction this must be reduced to  $4.9 \times 10^8$  lbs/ft<sup>2</sup>.

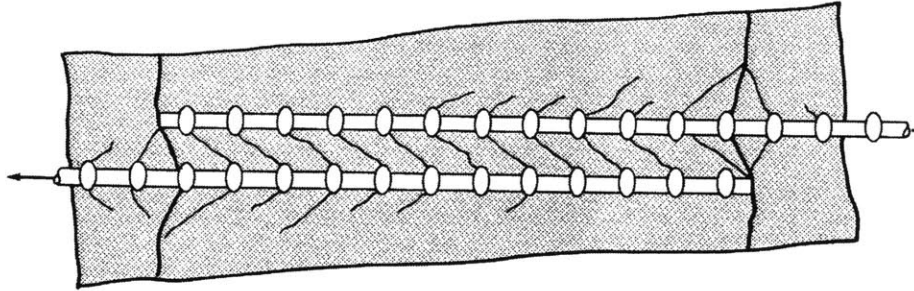
Combining these formula one can compare the movement predicted by idealized placement versus the actual movement that would be observed.

<u>v ideal</u>	<u>v actual</u>
0.31"	0.36"

This is a difference of approximately 15%.



### 6.3 Tension Lap Splice Design



**Fig 6.1** Sketch of a Lap Splice (MacGregor, 1997)

In order to prevent sudden failure and promote ductile behavior bars must be allocated enough length to fully develop their yield stress. Based on the theoretical equation presented in section 3.3 for development length and the data presented in section 5.5 a minimum length can be specified. For the purposes of this example a No.7 and grade 60 bar in 4000psi concrete will be examined.

Bonding:

$$\mu \text{ dry} = 0.40 f'c = 1600 \text{ psi}$$

$$\mu \text{ 10\% bentonite} = 0.15 f'c = 600 \text{ psi}$$

Bar properties:

$$f_y = 60,000 \text{ psi}$$

$$d_b = 0.875 \text{ in.}$$

Development length:

$$l_d = f_y d_b / 4\mu$$

$$l_d \text{ dry} = 8.2 \text{ inches}$$

$$l_d \text{ 10\% bentonite} = 21.9 \text{ inches}$$

The ACI code gives minimum overlap lengths for tension splices. For No.7 bars and larger in normal weight concrete:

$$l_d/d_b = f_y \alpha \beta / 20 \sqrt{f_c}$$

(MacGregor, 1997)

Here the term  $\mu$  has been replaced with a function of  $f_c$  and bond reduction factors  $\alpha$  and  $\beta$  have been applied. The bar location factor,  $\alpha$ , is a factor of safety for horizontal bars cast above 12 inches or more of concrete. For such bars there is the danger of water migrating up-wards as the concrete cures and collecting on the underneath side reducing interface contact. For this example the bar location factor will be dropped, to focus on the coating factor  $\beta$ . This is a term to account for the reduced bonding for bars, which have been coated in epoxy for corrosion protection. However, it can be modified to suit the needs of reduced bonding for slurry construction. In order to be afforded the same factor of safety for development length an equivalent code  $\beta$  factor for splices constructed under slurry should equal almost three. Obviously this is much too high to be practical, and the designer should minimize number of splices or place them at locations other than those expecting to see high stresses. When unavoidable, mechanical connectors or welds can be used to splice bars.

## **CHAPTER 7**

---

### **CONCLUSION**

In the end it is the contractors responsibility to construct what the engineer has designed. However if these designs do not allow for construction, the project does not even have a chance at success. One such unfortunate project was a 25-foot high earth retaining wall in South Africa. The soil behind the wall was compacted using a vibrating smooth-wheeled towed roller to get the density required for future development. The wall however was only designed to resist the weight of this dense material not the densification process itself. As a result the wall failed in bending at the base, even with what the engineers had thought was a conservative factor of safety.(Ingold,1985) Problems with this wall did not arise from applying standard reinforced concrete theory incorrectly to slurry construction, such as the ones pointed out in this paper. They were a result of neglecting the high-energy input of compaction. However, this is just one more step in construction worth of investigation.

In general an understanding of the construction process is needed to design effectively and to maintain an acceptable level of safety for our society. This understanding only comes with continued education. As contractors pressured by the bottom line try and experiment with new and innovative construction techniques, engineers and educational institutions need to keep up. Engineers are awarded the respect due to someone with the responsibility of protecting the public but this respect comes at a cost. Effort must be spent to investigate all plausible risks associated with a project.

In part, the motivation behind this thesis topic was to serve as a reminder of a number of fundamental lessons beyond the technical insights presented. It was hoped that the astute reader would make the connection between the few specific examples and how the construction process in general fits into the more global path from idea to project realization. The consideration given to this construction step in the path is crucial because it is coupled and interrelated with other steps, specifically design. Incorporating contingency plans to mitigate risks associated with a project is a goal of all designers. However, much of the risk comes about from the construction process. An educated handling of this risk can be gained by consulting with contractors during and throughout design. If nothing else, the author would hope that a realization of the importance of communication and foresight would be taken away from this thesis.

## ***REFERENCES***

---

Boyes, R., 1975. Structural and Cut-Off Diaphragm Walls. John Wiley & Sons, New York, USA.

Central Artery/Tunnel Project, web page, [http://www.bigdig.com/thtml/gw\\_sw.htm](http://www.bigdig.com/thtml/gw_sw.htm), 1999.

Chilingarian, G.V. and Vorabutr, P., 1983. Drilling and Drilling Fluids. Elsevier Science Publishing Company Inc., New York, USA.

Hajnal, Marton, Regele, 1984. Construction of Diaphragm Walls. John Wiley & Sons, New York, USA.

Ingold, T.S., 1985. "A Retaining Wall Failure Induced by Compaction," Failures in Earthworks. Thomas Telford Ltd., London, England.

Lambe, T.W. and Whitman, R.V., 1969. Soil Mechanics. John Wiley & Sons, New York, USA.

MacGregor, J.G., 1997. Reinforced Concrete: Mechanics and Design. Prentice Hall, Upper Saddle River, USA.

Mehta, P. and Monteiro, P., 1993. Concrete: Structure, Properties, and Materials. Prentice Hall, Englewood Cliffs, USA.

Millett, Perez, and Davidson, 1992. "USA Practice Slurry Wall Specifications 10 Years Later," Slurry Walls: Design, Construction, and Quality Control. American Society for Testing and Materials, Philadelphia, USA.

Popov, E.P., 1990. Engineering Mechanics of Solids. Prentice Hall, Englewood Cliffs, USA.

Reese, L.C. and Tucker, K.L., 1985. "Bentonite Slurry in Constructing Drilled Piers," Drilled Piers and Caissons II. American Society of Civil Engineers, New York, USA.

Schoenwolf, Whitman, Abbott, and Becker, 1992. "Post Office Square Garage Project: A Case History of Instrumented Slurry Wall Performance," Slurry Walls: Design, Construction, and Quality Control. American Society for Testing and Materials, Philadelphia, USA.

Tamaro, G.J. and Poletto, R.J., 1992. "Slurry Walls: Construction Quality Control," Slurry Walls: Design, Construction, and Quality Control. American Society for Testing and Materials, Philadelphia, USA.

Vanel, P., 1992. "Making Diaphragm Wall Joints Watertight with the CWS System," Slurry Walls: Design, Construction, and Quality Control. American Society for Testing and Materials, Philadelphia, USA.

Xanthakos, P.P., 1979. Slurry Walls. McGraw-Hill, New York, USA.

Xanthakos, P.P., 1994. Slurry Walls as Structural Systems. McGraw-Hill, New York, USA.