

**Visual - Haptic Interactions in Multimodal  
Virtual Environments**

by

Wan-Chen Wu

B.S., Mechanical Engineering  
National Taiwan University, 1996

Submitted to the Department of Mechanical Engineering  
in partial fulfillment of the requirements for the degree of

Master of Science in Mechanical Engineering

at the

MASSACHUSETTS INSTITUTE OF TECHNOLOGY

February 1999

© Massachusetts Institute of Technology 1999. All rights reserved.

Author .....  
Department of Mechanical Engineering  
January 4, 1999

Certified by .....  
Mandayam A. Srinivasan  
Principal Research Scientist, Dept. of Mechanical Engineering  
Thesis Supervisor

Accepted by .....  
Ain A. Sonin  
Chairman, Department Committee on Graduate Students

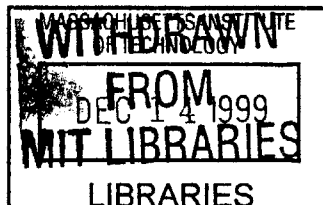

ENG

# Visual - Haptic Interactions in Multimodal Virtual Environments

by

Wan-Chen Wu

Submitted to the Department of Mechanical Engineering  
on January 4, 1999, in partial fulfillment of the  
requirements for the degree of  
Master of Science in Mechanical Engineering

## Abstract

Human perceptual abilities play a crucial role in the optimal design of virtual reality and teleoperator systems. This thesis is concerned with the human perception of virtual objects that can be touched and manually explored through a stylus, in addition to viewing them graphically. Two sets of psychophysical experiments were designed and conducted to investigate (1) the relative importance of force and torque feedback in locating virtual objects purely haptically and (2) the effect of 3D perspective visual images on the visual and haptic perception of size and stiffness of virtual objects.

In the first set of experiments, a novel hardware arrangement consisting of two force-reflecting haptic interfaces connected by a common stylus was used in conjunction with a new haptic display algorithm called ray-based rendering. The ability of subjects to identify the location of a thin plate orthogonal to the stylus was tested under several conditions ranging from reflecting only the force at the stylus tip to full force and torque feedback. The results show that it is important to display both force and torque if the objects whose location needs to be identified can lie anywhere within the haptic work space.

In the second set of experiments, virtual slots of varying length and buttons of varying stiffness were displayed to the subjects, who then were asked to discriminate their size and stiffness respectively using visual and/or haptic cues. The results of the size experiments show that under vision alone, farther objects are perceived to be smaller due to perspective cues and the addition of haptic feedback reduces this visual bias. Similarly, the results of the stiffness experiments show that compliant objects that are farther are perceived to be softer when there is only haptic feedback and the addition of visual feedback reduces this haptic bias. These results demonstrate that our visual and haptic systems compensate for each other such that the sensory information that comes from visual and haptic channels is fused in an optimal manner.

Thesis Supervisor: Mandayam A. Srinivasan

Title: Principal Research Scientist, Dept. of Mechanical Engineering

## Acknowledgments

Thank God. He never leaves me unattended.

Thank Srini for instructing me into this interesting field, and his patient guidance. He is such a knowledgeable advisor.

Thank my family for their constant love and support. Especially thank Dad for comforting and encouraging me when I was depressed and giving me advice about school work and everyday life; thank Mom for being my faithful prayer always; and thank Sis, Wan-Hua, for her accompanying my parents when I could be there.

Thank my colleagues in Touch Lab: Alex, Cagatay, Chih-Hao, Josh, Mandy, Raju, Suvranu and Tim, for their kind help and friendship.

Thank all the brothers and sisters who ever prayed for me in my life. Everything is impossible without them.

# Contents

<b>1</b>	<b>Introduction</b>	<b>10</b>
1.1	Hardware and Software Development in VEs . . . . .	10
1.2	Multisensory Perception in VEs . . . . .	12
<b>2</b>	<b>Haptic Exploration of Virtual Objects Using a Stylus</b>	<b>14</b>
2.1	Point and Ray Based Collision Detection Procedure in VEs . . . . .	14
2.2	Force and Torque Considerations . . . . .	15
2.3	Rendering for Side Collision . . . . .	16
2.4	Experiment . . . . .	19
2.4.1	Experimental Design . . . . .	19
2.4.2	Experimental Setup . . . . .	21
2.4.3	Experimental Results . . . . .	21
2.5	Stylus Extension . . . . .	23
2.5.1	Virtual Stylus . . . . .	23
2.5.2	Smoothness Loss and Improvement . . . . .	24
<b>3</b>	<b>Size Discrimination Experiments</b>	<b>27</b>
3.1	Experimental Goal . . . . .	27
3.2	Experimental Design . . . . .	27
3.2.1	Apparatus . . . . .	27
3.2.2	Slots . . . . .	28
3.3	Experimental Procedure . . . . .	31
3.3.1	Experiments with Both Visual and Haptic Cues . . . . .	31

3.3.2	Experiments with Visual Cues Only . . . . .	32
3.3.3	Experiments with Haptic Cues Only . . . . .	32
3.4	Experimental Results . . . . .	33
3.4.1	Experiments for Side-by-Side Slots with Both Visual and Haptic Cues . . . . .	33
3.4.2	Experiments for Rear-and-Front Slots with Visual and Haptic Cues . . . . .	34
3.4.3	Experiments for Side-by-Side Slots with Visual Cues Only . .	34
3.4.4	Experiments for Rear-and-Front Slots with Visual Cues Only .	34
3.4.5	Experiments for Side-by-Side Slots with Haptic Cues Only . .	35
3.4.6	Experiments for Rear-and-Front Slots with Haptic Cues Only	35
<b>4</b>	<b>Stiffness Discrimination Experiments</b>	<b>44</b>
4.1	Experimental Goal . . . . .	44
4.2	Experimental Design . . . . .	44
4.2.1	Apparatus . . . . .	44
4.2.2	Spring Buttons . . . . .	44
4.3	Experimental Procedure . . . . .	47
4.3.1	Experiments with Both Visual and Haptic Cues . . . . .	47
4.3.2	Experiments with Haptic Cues Only . . . . .	48
4.4	Experimental Results . . . . .	49
4.4.1	Experiments for Side-by-Side Buttons with Both Visual and Haptic Cues . . . . .	49
4.4.2	Experiments for Rear-and-Front Buttons with Both Visual and Haptic Cues . . . . .	49
4.4.3	Experiments for Side-by-Side Buttons with Haptic Cues Only	49
4.4.4	Experiments for Rear-and-Front Buttons with Haptic Cues Only	49
<b>5</b>	<b>Discussion on Size and Stiffness Discrimination Experiments</b>	<b>54</b>
5.1	Size Discrimination Experiments . . . . .	54
5.1.1	The Performance when Only Visual Cues were Provided . . . .	56

5.1.2	The Performance when Only Haptic Cues were Provided . . .	56
5.1.3	The Performance when Both Visual and Haptic Cues were Pro- vided . . . . .	59
5.2	Stiffness Discrimination Experiments . . . . .	62
5.3	Conclusions . . . . .	67
<b>6</b>	<b>Future Work</b>	<b>70</b>
6.1	Real Environment Experiments on Haptic Perspective . . . . .	70
6.2	Improvement Work on the (Extended) Stylus . . . . .	70
6.3	Human Experiments on the Extension of Stylus . . . . .	71
6.4	The Expansion of 5 DOF to 6 DOF . . . . .	71
6.5	Application of the Idea of Extending Stylus to Other Areas . . . . .	71

# List of Figures

2-1	(a)Point-based rendering (b)Ray-based rendering. . . . .	15
2-2	The illusion of torque resulting from ray-based rendering implemented on a single PHANToM. . . . .	16
2-3	The setup for reflecting forces and torques using two PHANToMs. . .	17
2-4	Rendering for side contact. . . . .	18
2-5	The collision detection model. . . . .	18
2-6	The calculated force R is realized through the applied forces F1 and F2. 19	
2-7	The stimulus for experiment. . . . .	20
2-8	The experimental setup. . . . .	21
2-9	Experimental results. . . . .	22
2-10	The extension of the physical stylus by adding a virtual one at the tip (or tail). . . . .	23
2-11	The cause of vibration. . . . .	25
2-12	Suggested solutions for minimizing vibration with virtually extended stylus. . . . .	26
3-1	The PHANToM. . . . .	28
3-2	Experimental setup. . . . .	29
3-3	The configuration of the slot sets (mm). . . . .	30
3-4	The perspective display parameters for the slot sets (mm). . . . .	30
3-5	The visual cues in size discrimination experiments for the S-S case. .	32
3-6	The visual cues in size discrimination experiments for the R-F case. .	33
3-7	The screen instructions for the haptic cues only condition. . . . .	34

3-8	The average results for side-by-side slots with visual and haptic cues.	38
3-9	The average results for rear-and-front slots with visual and haptic cues.	39
3-10	The average results for side-by-side slots with visual cues only. . . . .	40
3-11	The average results for rear-and-front slots with visual cues only. . . . .	41
3-12	The average results for side-by-side slots with haptic cues only. . . . .	42
3-13	The average results for rear-and-front slots with haptic cues only. . . . .	43
4-1	The configuration of the button sets (mm). . . . .	45
4-2	The perspective display parameters for the button sets (mm). . . . .	46
4-3	The 3D graphics shown for visual and haptic cues experiments. . . . .	48
4-4	The 2D top-view shown for haptic cues only experiments. . . . .	48
4-5	The results for side-by-side buttons with visual and haptic cues. . . . .	50
4-6	The results for rear-and-front buttons with visual and haptic cues. . . . .	51
4-7	The results for side-by-side buttons with haptic cues only. . . . .	52
4-8	The results for rear-and-front buttons with haptic cues only. . . . .	53
5-1	The expected result corresponding to perfect discrimination in both S-S and R-F cases. . . . .	55
5-2	The results when only visual cues were provided. . . . .	57
5-3	The results when only haptic cues were provided. . . . .	58
5-4	The results when both visual and haptic cues were provided. . . . .	59
5-5	The results for the side-by-side case. . . . .	60
5-6	The results for the rear-and-front case. . . . .	61
5-7	The expected results corresponding to perfect discrimination perfor- mance. . . . .	62
5-8	The results when only haptic cues were provided (with 2D visual cues). . . . .	63
5-9	The results when both visual and haptic cues were provided (with 3D visual cues). . . . .	64
5-10	The results for the side-by-side case. . . . .	65
5-11	The results for the rear-and-front case. . . . .	66
5-12	Fusion of sensory data in the size discrimination experiment. . . . .	68



# List of Tables

3.1	Slot sizes used in the experiments. . . . .	29
3.2	Slot sizes shown on the screen. . . . .	31
3.3	The results for each subject for side-by-side slots with visual and haptic cues. . . . .	35
3.4	The results for each subject for rear-and-front slots with visual and haptic cues. . . . .	36
3.5	The results for each subject for side-by-side slots with visual cues only.	36
3.6	The results for each subject for rear-and-front slots with visual cues only.	37
3.7	The results for each subject for side-by-side slots with haptic cues only.	37
3.8	The results for each subject for rear-and-front slots with haptic cues only. . . . .	38
4.1	The stiffness variation of the buttons. . . . .	46
4.2	The results for each subject for side-by-side buttons with visual and haptic cues. . . . .	50
4.3	The results for each subject for rear-and-front buttons with visual and haptic cues. . . . .	51
4.4	The results for each subject for side-by-side buttons with haptic cues only. . . . .	52
4.5	The results for each subject for rear-and-front buttons with haptic cues only. . . . .	53

# Chapter 1

## Introduction

### 1.1 Hardware and Software Development in VEs

Virtual Environments (VEs), referred to as Virtual Reality in the popular press, are computer generated environments with which users can interact in real-time. These environments can be multimodal and immersive as well and can be used to perform tasks that are dangerous, expensive, difficult or even impossible in real environments. Some of the application areas for VEs include Industry, Education, Medicine, Entertainment, and Marketing. The research work described in this thesis was conducted using a desktop VE system consisting of a computer monitor for visual display and a force reflecting haptic interface (PHANToM) to enable the user to touch and feel virtual objects. Since the use of haptic interfaces in perceptual experiments is quite new, a brief review of haptic machines and display software is described below (see also Srinivasan, 1995; Srinivasan and Basdogan, 1997).

One of the first force-reflecting hand controllers to be integrated into VEs was at the University of North Carolina in project GROPE (Brooks et al., 1990). Around the same time, two haptic interfaces were built at MIT: the MIT Sandpaper, a force-reflecting 2-DOF joystick able to display virtual textures (Minsky et al., 1990); the Linear Grasper, which consisted of two vertical parallel plates whose resistance to squeezing was determined by two motors controlled by a computer (Beauregard and Srinivasan, 1997). In Japan, desktop master manipulators were developed in Tsukuba

(Iwata, 1990; Noma and Iwata, 1993). At the University of British Columbia 6-DOF, low-inertia and low friction hand controllers were built by taking advantage of magnetic levitation technology (Salcudean et al., 1992). The haptic interface we used in this research, PHANToM, was designed at the MIT Artificial Intelligence Laboratory (Massie and Salisbury, 1994). It is a low-inertia device with three active degrees of freedom and three additional passive degrees of freedom, which can convey the feel of virtual objects through a thimble or a stylus.

Since haptic interfaces for interacting with VEs are quite recent, the software for generating and rendering tactual images is in the early stages of development. The development of efficient and systematic methods of rendering in a multimodal environment is essential for a high-quality simulation. The methods for point-based touch interaction with virtual objects was first developed by Salisbury et al. (1995). A constraint-based god-object method for generating convincing interaction forces was also proposed, which modeled objects as rigid polyhedra (Zilles and Salisbury, 1995). Haptic display of deformable objects was also accomplished in the same year (Swarup, 1995). Compact models of texture, shape, compliance, viscosity, friction, and deformation were then implemented using a point force paradigm of haptic interaction (Massie, 1996).

At the MIT Touch Lab, several haptic display algorithms and the associated rendering software have been developed. To display smooth object shapes, a haptic rendering algorithm called “Force Shading” was developed (Morgenbesser and Srinivasan, 1996). It employs controlled variation in the direction of the reflected force vector to cause a flat or polyhedral surface to be perceived as a smooth convex or concave shape. To facilitate rapid building of specific virtual environments, a tool kit called “MAGIC” has been developed (Hou and Srinivasan, 1998). It provides the user with virtual building blocks that can be displayed visually and haptically. The user can select primitive shapes such as cylinders, spheres, cubes and cones; move them and change their size, stiffness, and color; combine several primitive shapes to form a new, more complex object; save the scene for future use. Besides, a new haptic rendering software called “HapticC-Binder” was developed to enable the user

to interact with general polyhedral objects (Basdogan and Srinivasan, 1996). All the haptic rendering software discussed above uses so called “point-based” method (see Srinivasan and Basdogan, 1997, for a review). In this procedure, the probe is simply modeled as a point, and the force applied depends only on the depth the point penetrates into the objects.

A “ray-based” rendering procedure was later proposed (Basdogan et. al., 1997), in which the probe is modeled as a line segment. The ray-based haptic interaction technique handles collisions of objects with the side of the probe in addition to those with its tip, and therefore can provide additional haptic cues for conveying the existence and properties of objects. To implement this new rendering methodology, some modification of hardware setup became necessary due to the need for the reflected resultant force to be located at any point along the stylus. Two PHANToms were attached to the two ends of a stylus so that both force and torque could be reflected to the user. In the next chapter, we describe an experiment that was designed and carried out to investigate the influence of force and torque on human perception of virtual object location under purely haptic feedback.

## 1.2 Multisensory Perception in VEs

Over the past few years, the topic of multisensory perception in virtual environments has aroused the interest of many researchers owing to a wide variety of applications of VEs. With recent advances in haptic interfaces and rendering techniques (Srinivasan and Basdogan, 1997), we can now integrate vision and touch into VEs to study human perception and performance. Compared to the experiments in the real world, the VE technology enables better control over the stimuli needed to gain insight into human multimodal perception. In particular, understanding the sensory interactions between vision and touch can have a profound effect on the design of effective virtual environments.

Ample evidence based on real world experiments has shown that visual information can alter the haptic perception of spatial properties like size, range, location, and

shape (reviewed by Heller and Schiff, 1991). For example, it is known that for spatial information, we rely more on the visual cues than kinesthetic ones when the visual information conflicts with the haptic information. However, it is not clear under what conditions this is true. For example, previous research studies have shown that visual and haptic modalities not only work in competition, but sometimes the combined information from the two can improve the human perception of objects properties (Heller, 1982; Manyam, 1986).

In studies concerning multimodal perception in VEs, it has been shown that vision and sound can affect the haptic perception of stiffness (Srinivasan et al., 1996; DiFranco et al., 1997). In the study investigating the relationship between visual and haptic perception, strong dominance of visual position information over kinesthetic hand position information resulted in a compelling multimodal illusion (Srinivasan et al., 1996). Spring stiffnesses that were easily discriminable under purely haptic conditions were increasingly misperceived with increasing mismatch between visual and haptic position information, culminating in totally erroneous judgments when the two were fully in conflict. In the study on perceptual interactions between sound and haptics, it was shown that sharper impact sounds caused many subjects to overestimate the stiffness of the object they were tapping, but this illusion was not uniformly strong for all the subjects (DiFranco et al., 1997).

In Chapters 3 to 5 of this thesis, our investigation on the influence of perspective visual cues on the human perception of object properties has been described. The role of 3D perspective graphics in multimodal VEs is important since it is a natural representation of a wide field visual scene, but involves nonlinear transformation of object geometries and therefore could result in a variety of perceptual illusions. Two separate sets of experiments were designed and conducted to investigate the effect of 3D visual perspective on the visual and haptic perception of object size and stiffness. The motivation behind each experiment is explained, along with the details of the experimental design and the results obtained.

## Chapter 2

# Haptic Exploration of Virtual Objects Using a Stylus

### 2.1 Point and Ray Based Collision Detection Procedure in VEs

The conceptual differences between point and ray based haptic rendering is illustrated in figure 2-1. In the middle of the figures are the visual images displayed to the subjects. On the left, the type of collision detection and the associated force computation method is shown. In point-based rendering, the end-effector of the haptic interface is represented as a point cursor and the force reflected depends only on its depth of penetration into the sphere. But in ray-based rendering, the collision of the whole stylus, tip as well as side, with virtual objects is taken into account. The force as well as torque reflected depends on the depth of penetration of both the plane below contacting the tip of the stylus and the cube above contacting its side. The figures on the right indicate that only pure force is reflected back in the case of point-based methods, whereas both force and torque can be reflected back in the case of ray-based rendering.

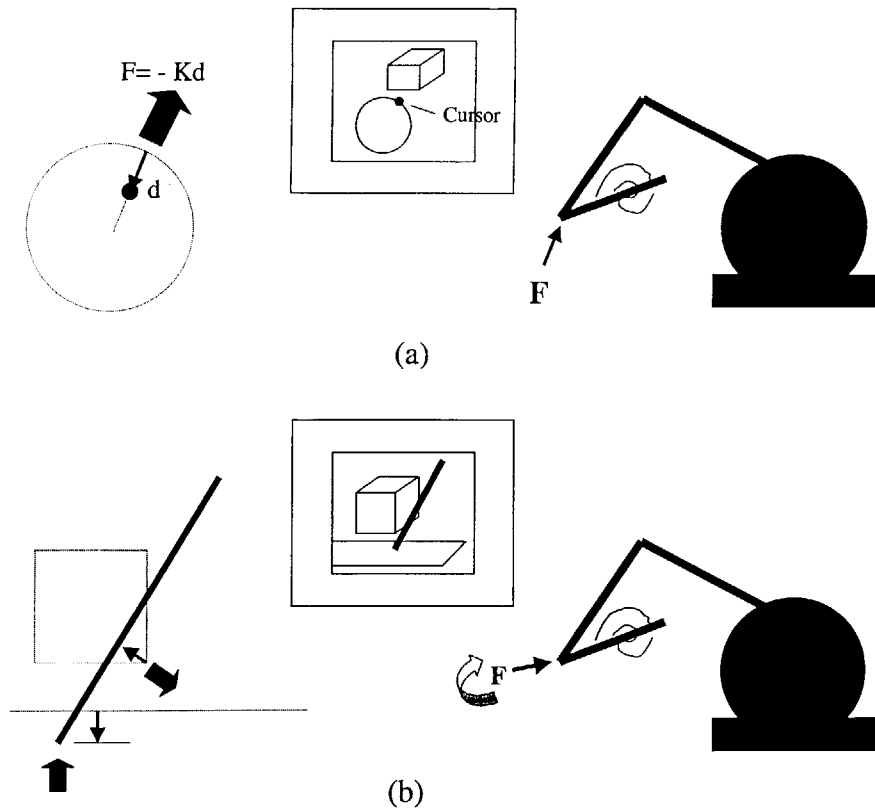

Figure 2-1: (a)Point-based rendering (b)Ray-based rendering.

## 2.2 Force and Torque Considerations

Irrespective of the capabilities of the rendering algorithms to capture only force or force and torque to be reflected, with the use of a single PHANToM device only a resultant force can be displayed to the user. In spite of the absence of torque, we felt an illusion of side collisions even when a single PHANToM was used in our preliminary experiments. A similar experience has been reported by Hancock, 1996. This illusion may be explained as due to our ability to perceive invariants during active explorations with the hand in a specified geometric environment. For example, as shown in figure 2-2, several straight lines representing the successive positions and orientations of the stylus can intersect at only one point whose position in space is invariant, that may be how we can perceive the existence of the cube vertex even in the absence of torque feedback.

In order to sort out the roles of force and torque in perceiving location of contact with objects, we connected two PHANToMs with a common stylus (figure 2-3). The

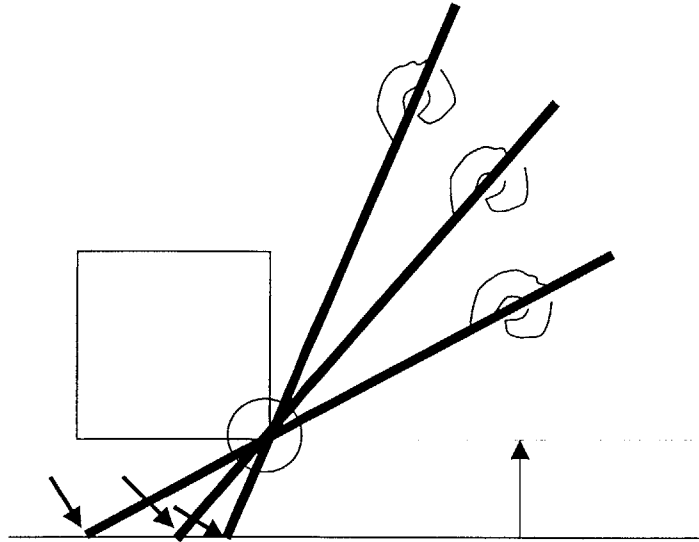

Figure 2-2: The illusion of torque resulting from ray-based rendering implemented on a single PHANToM.

resulting device was capable of reflecting back force and/or torque to the user.

## 2.3 Rendering for Side Collision

A simplified haptic environment was designed specifically for investigating side collisions with this improved hardware setup and is shown schematically in figure 2-4. The virtual object contacting the stylus is always a vertical plate below the stylus. The plate is assumed to be infinitesimally thin and without friction so as to eliminate any cues other than a vertical contact force in detecting the position of the plate. The collision detection model is as shown in figure 2-5: it is only necessary to detect whether the point on the stylus with the same  $z$  position as the plate (point H) is below the top of the plate. If so, an appropriate force proportional to the depth of penetration is calculated ('R' in figure 2-6), and the corresponding forces ( $F_1$  and  $F_2$ ) whose resultant is R are sent from each of the PHANToMs. The algorithm used for



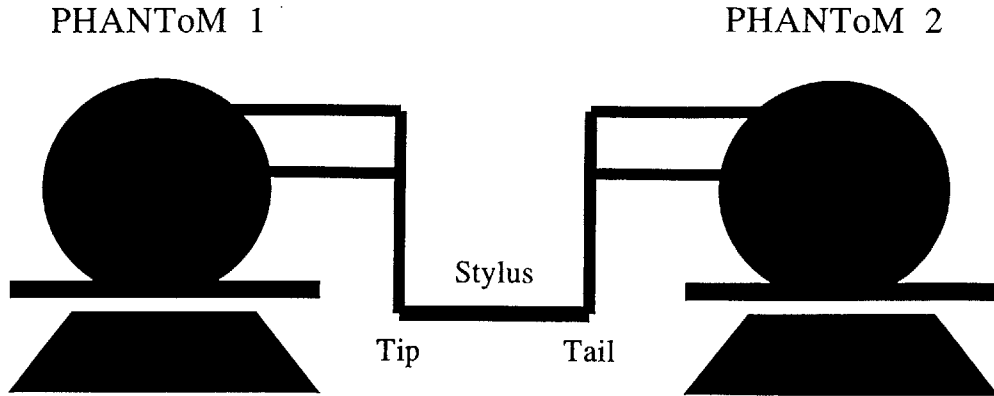

Figure 2-3: The setup for reflecting forces and torques using two PHANToMs.

detecting collision and calculating the reaction force  $R$  is given below.

Get tip and tail coordinates	$(X1, Y1, Z1) = GetPos(PHANToM1)$
	$(X2, Y2, Z2) = GetPos(PHANToM2) + (0, 0, L)$
↓	
Find the point H with the same	$Zh = Zp$
Z coordinates as the plate	$Yh = Y1 + (Y2 - Y1)(Zh - Z1)/(Z2 - Z1)$
↓	
Check if point H is lower	
than the plate top	$IF((d = Yh - Yp) < 0)$
↓ Yes	
Calculate force R from	$R = -STIFFNESS * d$
depth d by Hooke's Law	

Because of the simplicity of the haptic environment and the rendering method, very high update rates (up to 17000 updates/sec) were achieved and led to a high quality of the feel of contact between the stylus and the vertical plate.

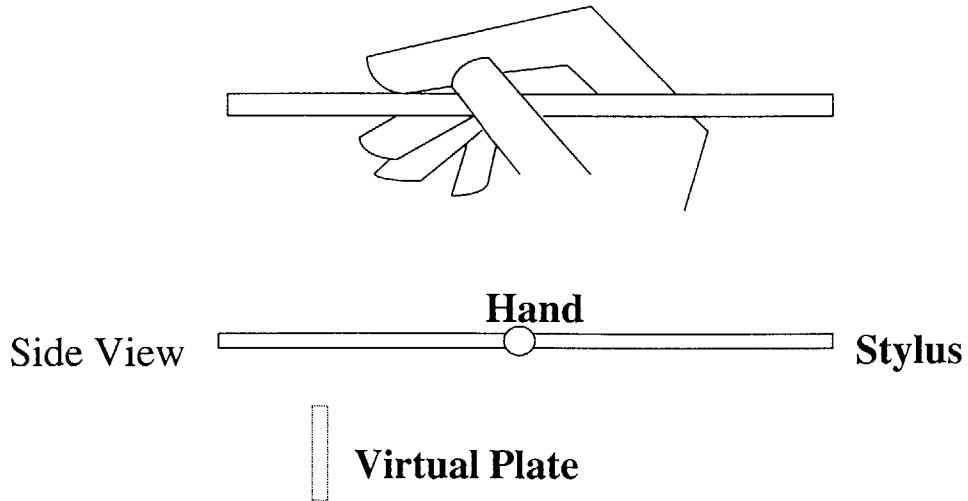

Figure 2-4: Rendering for side contact.

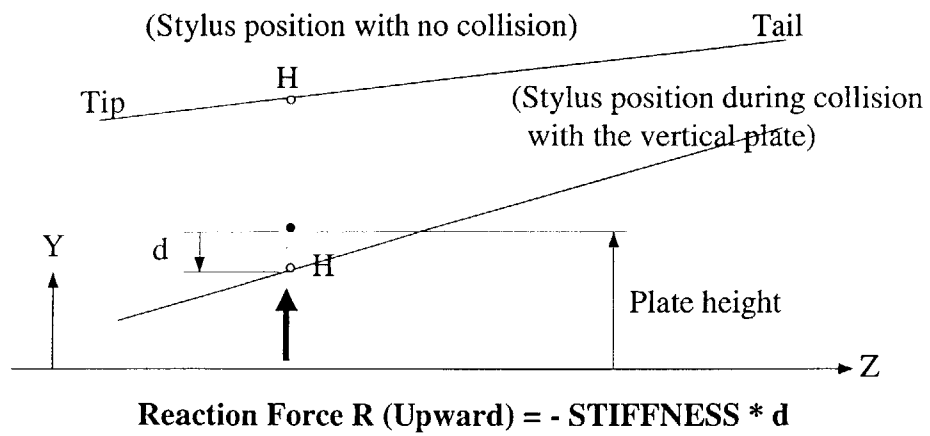

Figure 2-5: The collision detection model.

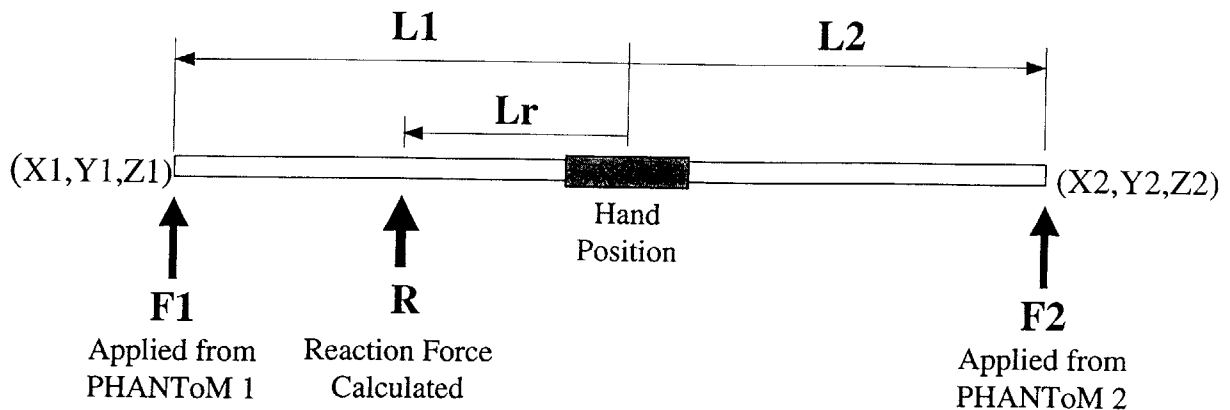

Figure 2-6: The calculated force  $R$  is realized through the applied forces  $F1$  and  $F2$ .

## 2.4 Experiment

An experiment was run using this rendering model to test the role played by forces and torques in object position detection.

### 2.4.1 Experimental Design

The stimulus is still the virtual vertical plate, but the position of the plate is varied as front, middle, and back, as shown in figure 2-7. Four kinds of force displays were considered: tip force, pure force, pure torque, and force with torque.

The tip force condition is identical to using only one PHANToM connected to the front tip. The force is of the same magnitude as the calculated  $R$ , but is reflected at the tip with PHANToM 1 only. In the pure force condition, the forces reflected at the tip and tail with each of the two PHANToMs will result in a resultant force with the same magnitude as the calculated  $R$ , but is located at the grasp point so that there is no torque with respect to the human hand. In the pure torque condition, the forces reflected at the tip and tail will result in the same torque at the grasp point as that from the calculated  $R$ , but the resultant force with respect to the hand will be zero. In the force with torque condition, the forces sent at the tip and tail will result in the

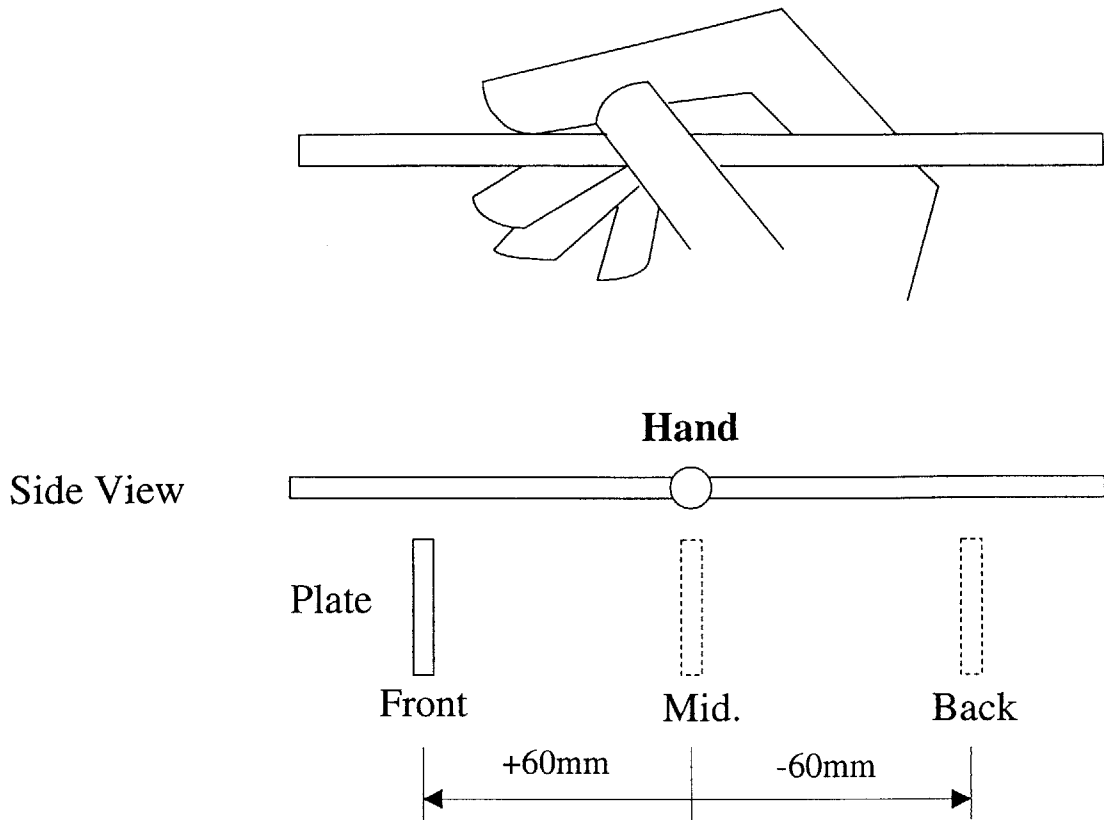

Figure 2-7: The stimulus for experiment.

same force magnitude and torque at the grasp point as that from the calculated  $R$ . These four conditions are listed below (The variables are defined in figure 2-6.).

Tip Force	$F1 = R$
	$F2 = 0$
Pure Force	$F1 + F2 = R$
	$L1 \times F1 + L2 \times F2 = 0$
Pure Torque	$F1 + F2 = 0$
	$L1 \times F1 + L2 \times F2 = Lr \times R$
Force+Torque	$F1 + F2 = R$
	$L1 \times F1 + L2 \times F2 = Lr \times R$

In this experiment, there were totally 12 conditions. 10 subjects participated in this experiment, with each stimulus repeated 20 times. Each time the subject explored the virtual plate with the stylus and judged the position of the plate by

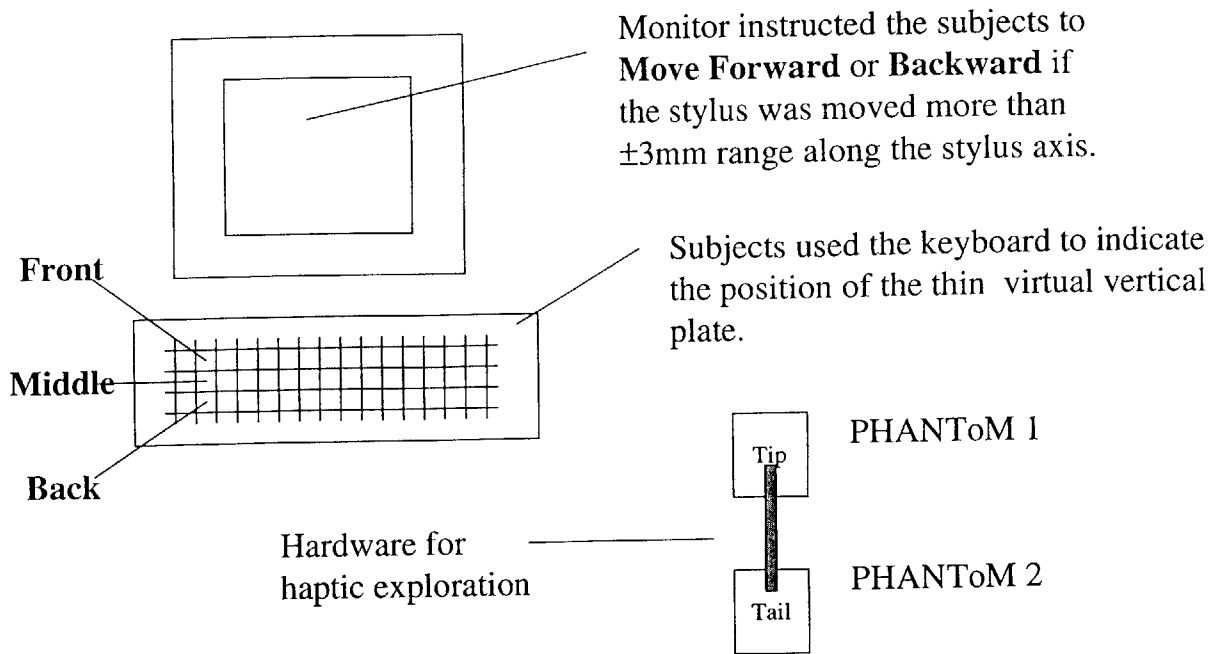

Figure 2-8: The experimental setup.

picking 'front', 'middle', or 'back' as the response.

## 2.4.2 Experimental Setup

The experimental setup is as shown in figure 2-8. Because all the 10 subjects were right-handed, the haptic device was placed on the right. The keyboard was for the subjects to indicate their response - 'front', 'middle', or 'back' - after they explored the virtual plate. To prevent the subjects from moving the stylus too far out along its axis with respect to its initial zero position, the monitor was programmed to display "Move Forward" or "Move Backward" if the stylus was moved out of a  $\pm 3\text{mm}$  range along the forward or backward direction.

## 2.4.3 Experimental Results

The results of the experiment are shown in figure 2-9. In the case of the tip force, the subjects almost always perceived the vertical plate to be in the front. It shows

**% Response**

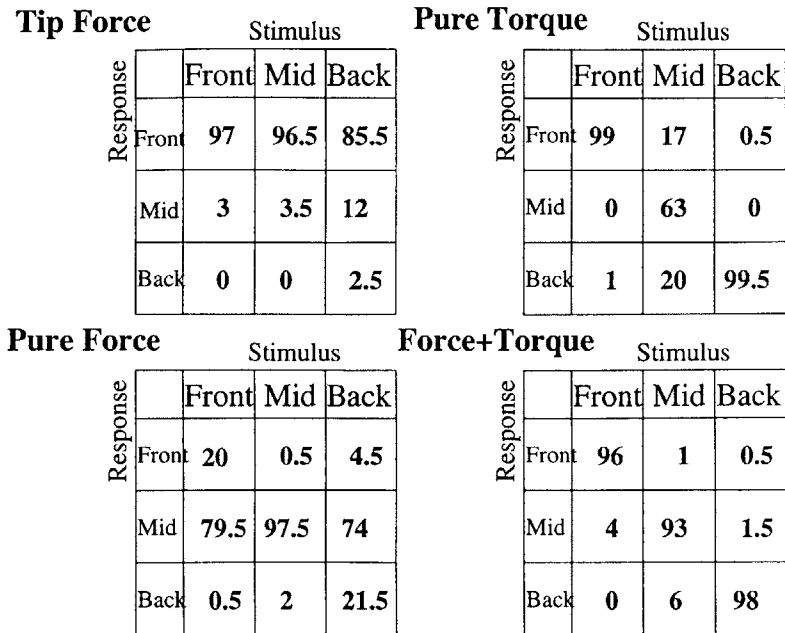

Figure 2-9: Experimental results.

that the illusion we mentioned in section 2.2 is only restricted to the cases when the virtual object is close to the tip. The display of ‘pure force’ caused the subjects to judge the vertical plate to be in the center in most of the trials. Although it seems to give very poor cues in judging object positions, in some cases the subjects did perceive the true position, as indicated by approximately 20% correct responses for the front and back positions. In the case of pure torque, the subjects could judge pretty well when the plate was in the front or back, but performance was poor when the plate was at the middle. In the force with torque case, the subjects judged all the three object positions extremely well.

From these results, we can see that torque plays a vital role in object position detection, and reflecting both forces and torques is important when the object is located anywhere along the stylus.

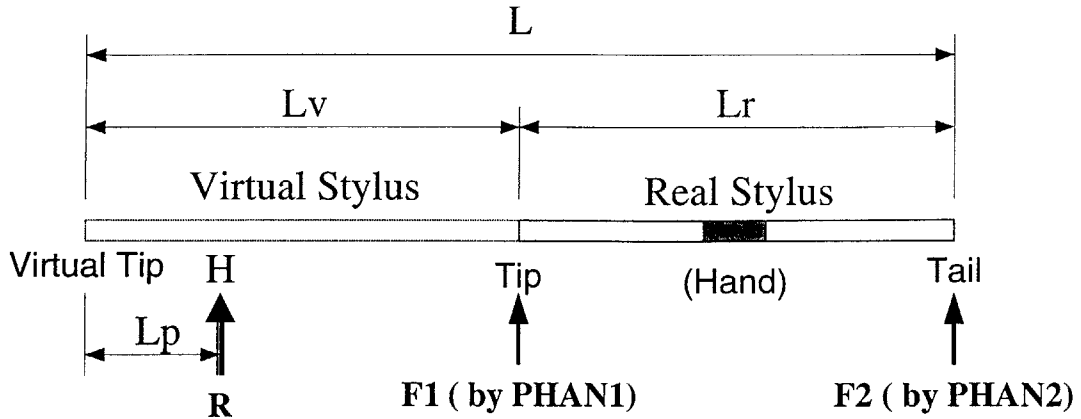

Figure 2-10: The extension of the physical stylus by adding a virtual one at the tip (or tail).

## 2.5 Stylus Extension

### 2.5.1 Virtual Stylus

When two PHANToMs are connected for force + torque feedback, due to the limited length of the stylus and a reduction of the haptic workspace, the reachable objects need to be located within a small region around the stylus. But with proper display of forces with the two machines, this limitation can be overcome by virtually extending the stylus.

The general idea of extension of stylus is shown in figure 2-10. The physical stylus of the PHANToM is extended by adding a virtual stylus to the tip (or tail). The collision detection algorithms are modified to include the virtual stylus. Then  $F_1$  and  $F_2$  are applied from each of the machines to result in appropriate forces and torques at the grasp point. The general algorithm is shown as below.

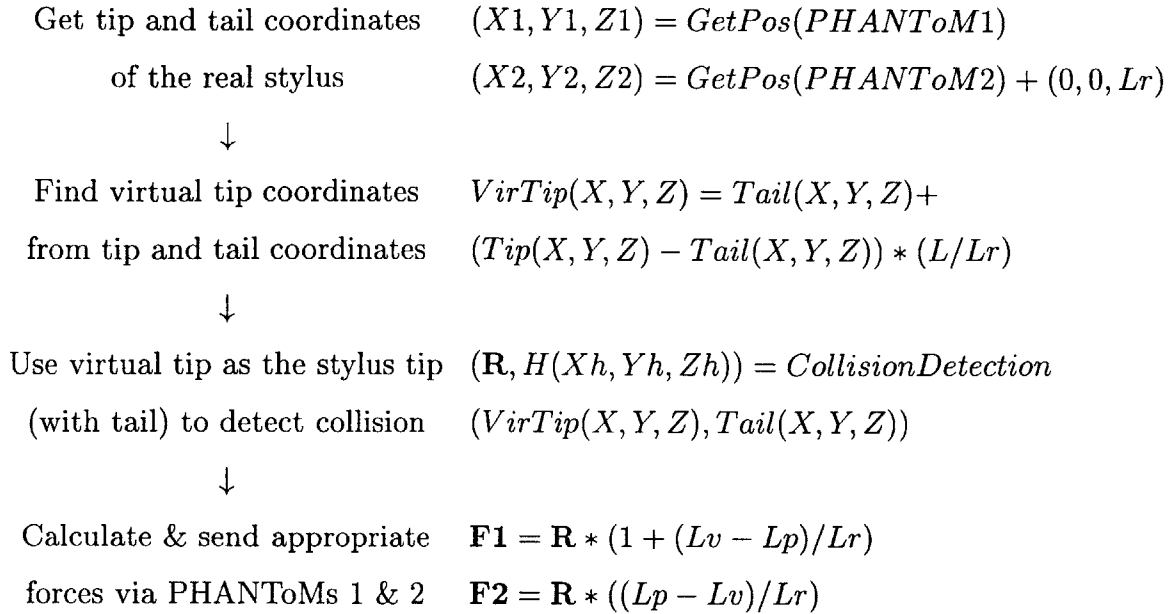

## 2.5.2 Smoothness Loss and Improvement

When reaching and touching the objects that are far away using the virtual extension to the stylus, sometimes there is loss of the original smoothness of contact, or even vibrations can occur. The reason, as shown in figure 2-11, is that it is more difficult to control the tip of the stylus when the tip is far away. Even when the hand moves very little, the point on the stylus near the virtual tip can transverse a large distance. If we use vertical plates with the same height as before, in the same time interval, the virtual stylus penetrates the object (A) much more than object B. But the force reflected back is not a smooth curve over time if it is updated with a frequency of about 1 kHz. Therefore, in the same time interval, according to the elastic law (force proportional to depth of penetration), the force increases due to contact with the farther object is larger and the force vs. time curve is steeper. Therefore, the force does not increase as smoothly for farther objects as for closer collisions.

Some methods to improve haptic rendering in this situation is shown in figure 2-12. The original case is shown in the top row. The force vs. time curve is steeper at the virtual tip when it collides with virtual objects. One way to solve this problem



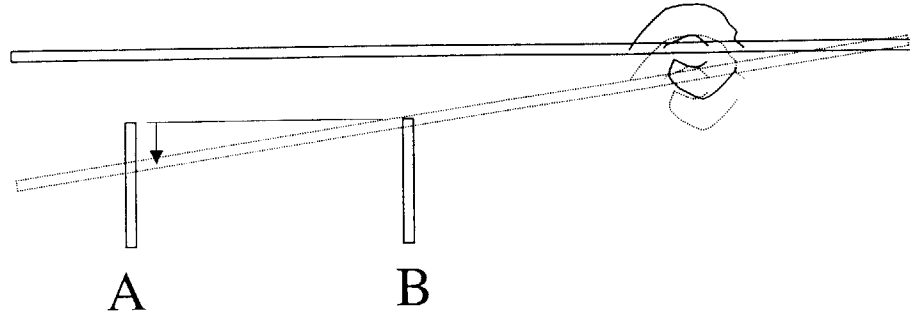

Figure 2-11: The cause of vibration.

is to increase the update frequency as shown in the second row. In this way, even though the slope of the force vs. time curve is still steeper, the force increase has more steps and therefore is smoother. The second way is to adjust the object stiffness depending on the distance of the objects (or collision point) to the hand position. The difference in the slopes of the force vs. time curves can then be reduced as shown in the third row in the figure. It should be noted that even with two real objects with equal stiffness, when contacted with a rigid stick, the force rate for the farther object will be higher than for the one closer to the hand. In addition to these two fixes, proper damping can be added instead of using pure elastic law, in order to smooth out the transients.

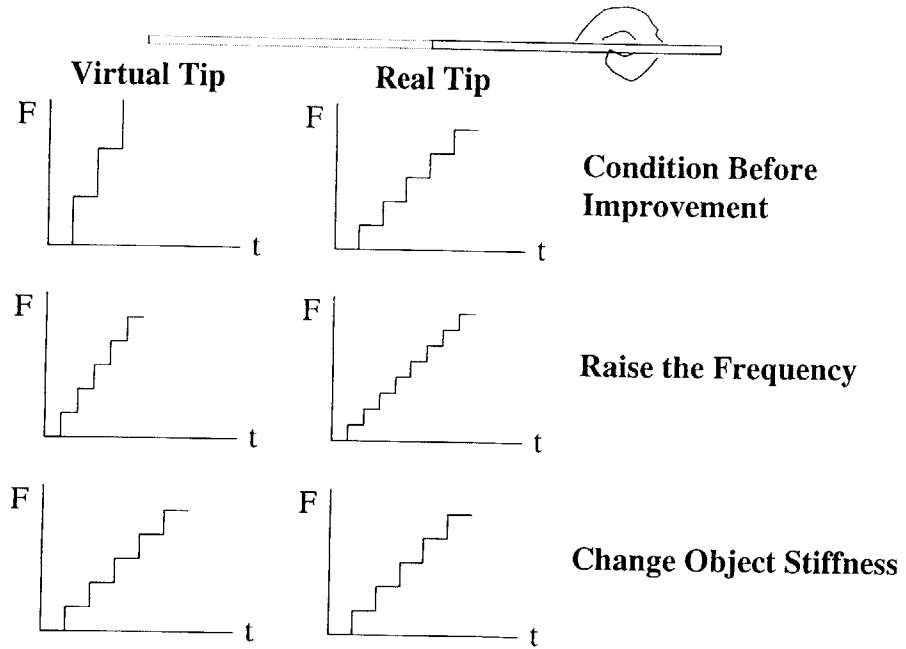

Figure 2-12: Suggested solutions for minimizing vibration with virtually extended stylus.

# Chapter 3

## Size Discrimination Experiments

### 3.1 Experimental Goal

Experiments were designed to test the effect of visual perspective on the visual and haptic perception of object size. Due to the visual perspective, objects that are farther from us appear smaller in 3D space. The purpose of these experiments is to investigate how well subjects allow for this nonlinear distortion during purely visual discrimination, the corresponding perceptual performance during purely haptic exploration of the objects, and the perceptual interactions when both visual and haptic displays are used.

### 3.2 Experimental Design

#### 3.2.1 Apparatus

These experiments were conducted with an A-Model (version 1.5) high resolution PHANToM haptic interface (figure 3-1) and an SGI workstation. The subject sat in a chair approximately 27 inches away from a 19-inch monitor. Since all the subjects were right-handed, the PHANToM was located to the right hand side of the subject and a black curtain was hung to prevent the subjects from viewing their hands during the experiments. The computer keyboard was located in front of the subject for

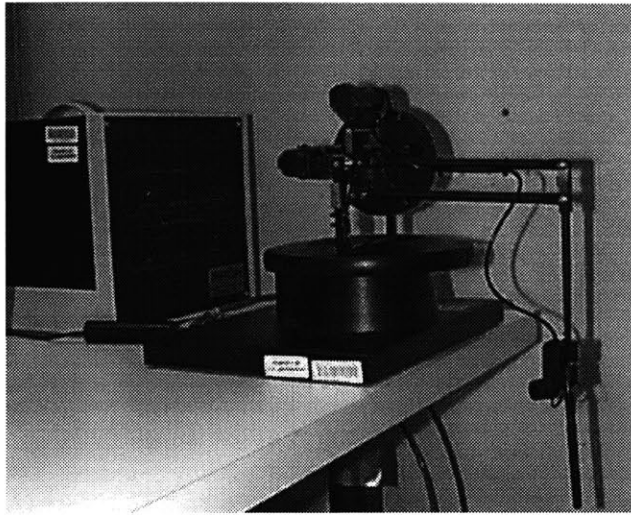

Figure 3-1: The PHANToM.

recording their answers. The experimental setup is shown in figure 3-2.

### 3.2.2 Slots

The stimuli were a pair of virtual slots, which were placed either side-by-side (S-S) or rear-and-front (R-F). The slots in the haptic environment were  $4mm$  in width and  $3mm$  in depth, embedded on a virtual plate with dimension  $200mm * 100mm * 20mm$ . The length of the right (or front) slot was kept at  $30mm$ , referred to as the standard slot, with the length of the left (or rear) slot varying among increments of  $-20%$ ,  $-10%$ ,  $-5%$ ,  $+5%$ ,  $+10%$ ,  $+20%$ ,  $+30%$ , and  $+40%$  of the standard one, referred to as the variable slot. The details of variations in slot lengths are shown in table 3.1 and in figure 3-3. The slots were graphically displayed to the subjects using 3D OpenInventor, with the perspective visual display parameters as shown in figure 3-4 and the sizes shown on the screen under this condition are listed in table 3.2. Each pair of slots was displayed to the subjects at the same time and the length of the variable slot was altered from trial to trial in random order. However, the sequence of stimuli that were displayed to each subject was the same.

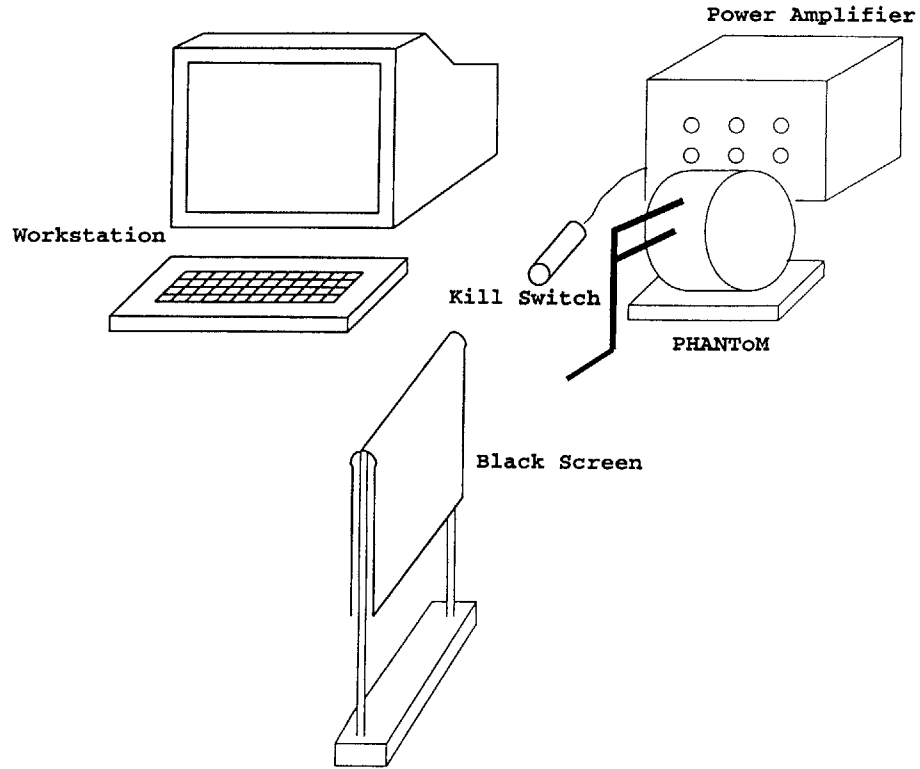

Figure 3-2: Experimental setup.

Variation Percentage	Side by Side (S-S)		Rear and Front (R-F)	
	Right(Std.)(mm)	Left(Var.)(mm)	Front(Std.)(mm)	Rear(Var.)(mm)
-20%	30.00	24.00	30.00	24.00
-10%	30.00	27.00	30.00	27.00
-5%	30.00	28.50	30.00	28.50
5%	30.00	31.50	30.00	31.50
10%	30.00	33.00	30.00	33.00
20%	30.00	36.00	30.00	36.00
30%	30.00	39.00	30.00	39.00
40%	30.00	42.00	30.00	42.00

Table 3.1: Slot sizes used in the experiments.

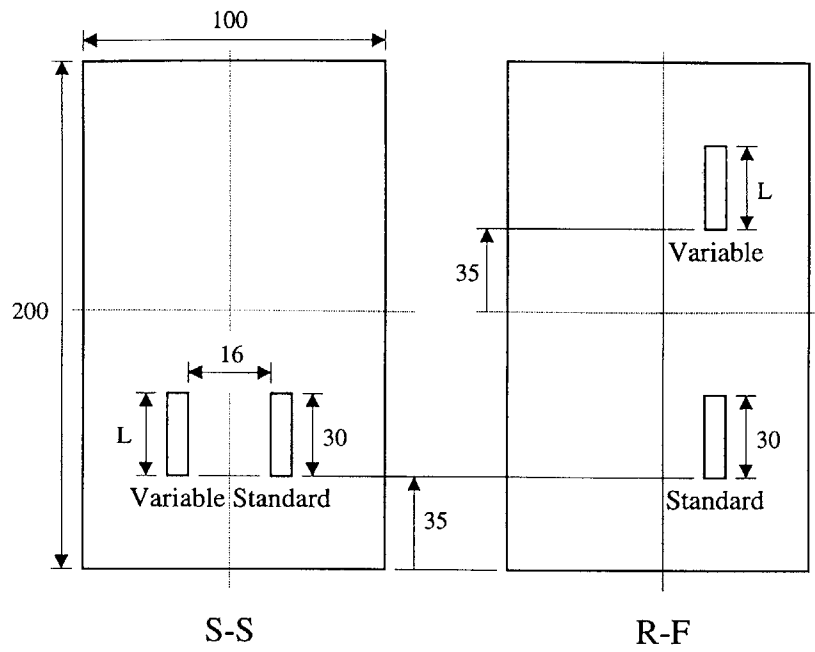

Figure 3-3: The configuration of the slot sets (mm).

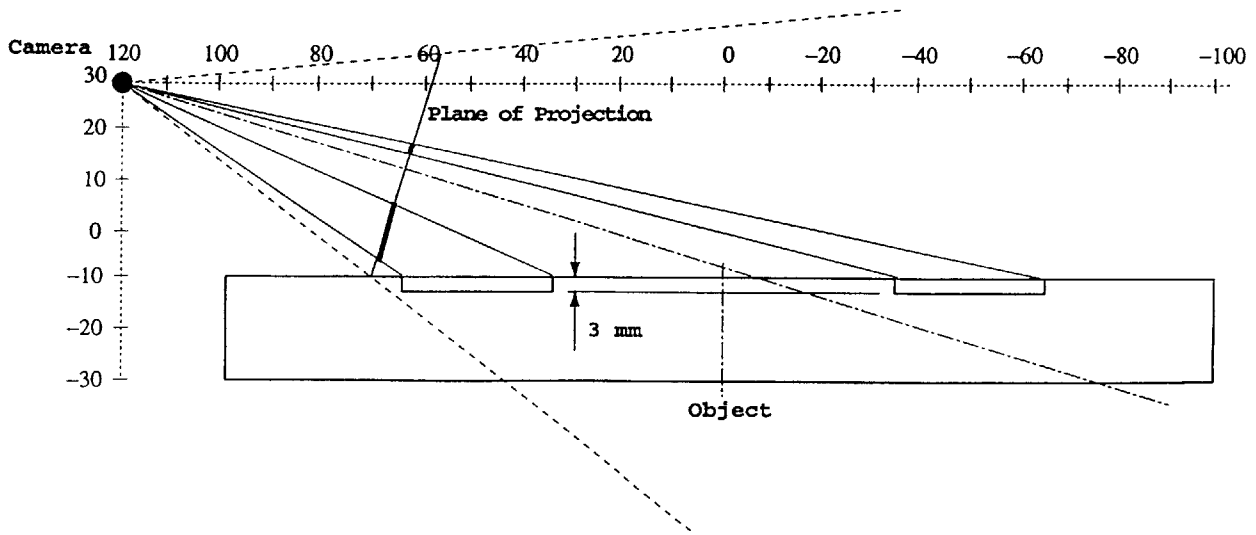

Figure 3-4: The perspective display parameters for the slot sets (mm).

Variation Percentage	Side by Side (S-S)		Rear and Front (R-F)	
	Right(Std.)(mm)	Left(Var.)(mm)	Front(Std.)(mm)	Rear(Var.)(mm)
-20%	63.46	54.11	63.46	10.34
-10%	63.46	58.93	63.46	11.46
-5%	63.46	61.23	63.46	12.00
5%	63.46	65.61	63.46	13.06
10%	63.46	67.70	63.46	13.58
20%	63.46	71.71	63.46	14.60
30%	63.46	75.49	63.46	15.58
40%	63.46	79.06	63.46	16.54

Table 3.2: Slot sizes shown on the screen.

### 3.3 Experimental Procedure

Ten right handed subjects (four females and six males) aged 18 - 30 participated in these experiments. None of them had any prior experience with the PHANToM. Before each session, the subject was asked to read the instructions for the experiment and sign a consent form for participating in the experiment. A practice session lasting 15 minutes was offered to make sure that the subjects understood how to use the PHANToM and felt comfortable with handling the stylus. At the start of each block of trials, the subject was asked to center the stylus of PHANToM to ensure the same starting position for each trial. At the end of the experiments, the subjects were encouraged to describe the strategy they used in performing the assigned task.

Each subject was required to attend three sessions over a period of 3 to 7 days, and participated in discrimination experiments under a total of 48 stimulus conditions (8 variations in the variable slot size, 2 slot pair configurations (S-S, R-F), and 3 display cases (visual, haptic, and visual + haptic) as described below), with 20 trials for each stimulus condition.

#### 3.3.1 Experiments with Both Visual and Haptic Cues

In the first session, each subject was asked to view the 3D perspective graphics on the screen (figures 3-5 and 3-6) and move the stylus to explore both the slots and judge which slot was longer. A visual cursor was displayed to help the subject navigate in

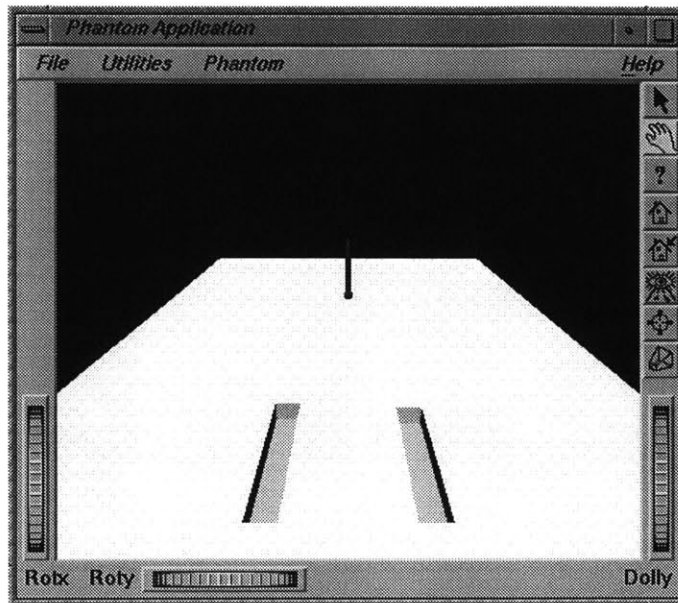

Figure 3-5: The visual cues in size discrimination experiments for the S-S case.

the 3D virtual world and explore the slots easily. The blocks of trials with S-S and R-F conditions were alternated to minimize any possible effect of training in biasing the results for one condition relative to the other. The answers input by the subjects to indicate which slot was longer were either “←” key for the left slot and “→” key for the right slot, or “↑” key for the rear slot and “↓” key for the front slot.

### 3.3.2 Experiments with Visual Cues Only

In the second session, the subjects were asked not to use the PHANToM, but to judge the length of the slots based only on the 3D perspective graphics display on the screen.

### 3.3.3 Experiments with Haptic Cues Only

In this session, each subject was asked to use the PHANToM again, but instead of showing the images of the slots, the screen only offered information on whether the stylus was on the left (or rear) or right (or front) side, as in figure 3-7, to help the



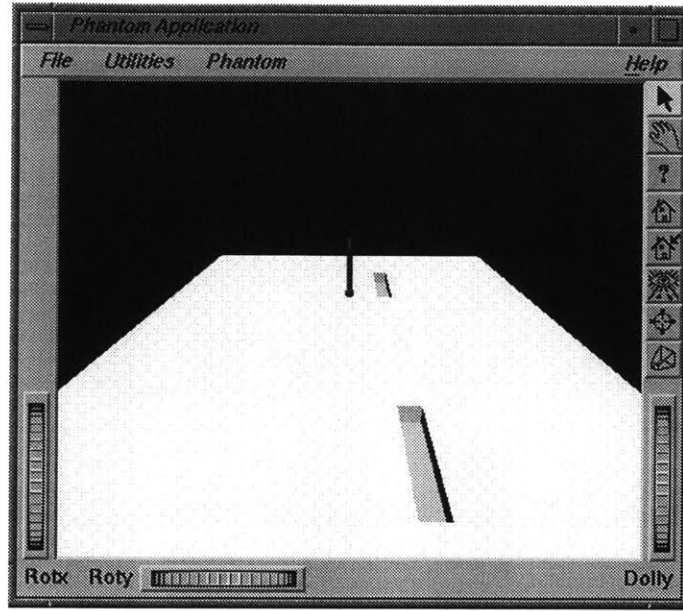

Figure 3-6: The visual cues in size discrimination experiments for the R-F case.

subjects with locating the slots. In this way, their judgment of the length depended only on haptic cues.

## 3.4 Experimental Results

We analyzed the results in terms of the percentage of trials in which the subject judged that the variable slot (the left one in S-S case and the rear one in R-F case) was longer.

### 3.4.1 Experiments for Side-by-Side Slots with Both Visual and Haptic Cues

The results for this experiment are listed in table 3.3. The values for each subject have been averaged over the 20 trials in each condition. The plot for the average over all the subjects and its range for 95% confidence in the results is shown in figure 3-8.

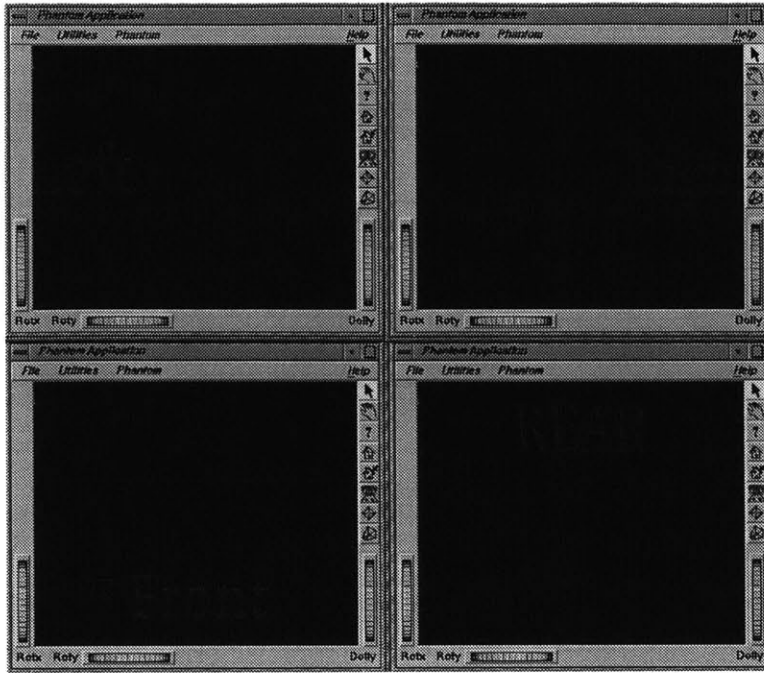

Figure 3-7: The screen instructions for the haptic cues only condition.

### **3.4.2 Experiments for Rear-and-Front Slots with Visual and Haptic Cues**

The results for this experiment are listed in table 3.4. The values for each subject have been averaged over the 20 trials in each condition. The plot for the average over all the subjects and its range for 95% confidence in the results is shown in figure 3-9.

### **3.4.3 Experiments for Side-by-Side Slots with Visual Cues Only**

The results for this experiment are listed in table 3.5. The values for each subject have been averaged over the 20 trials in each condition. The plot for the average over all the subjects and its range for 95% confidence in the results is shown in figure 3-10.

### **3.4.4 Experiments for Rear-and-Front Slots with Visual Cues Only**

The results for this experiment are listed in table 3.6. The values for each subject have been averaged over the 20 trials in each condition. The plot for the average over

%Response the Variable Slot perceived Longer(in %)								
S	-20%	-10%	-5%	5%	10%	20%	30%	40%
1	0	0	0	100	100	100	100	100
2	0	0	0	100	100	100	100	100
3	0	0	0	100	100	100	100	100
4	0	0	0	95	100	100	100	100
5	0	0	0	100	100	100	100	100
6	0	0	0	100	100	100	100	100
7	0	0	0	100	100	100	100	100
8	0	5	10	85	100	95	100	100
9	0	0	5	100	100	100	100	100
10	0	0	5	100	100	100	100	100
Av	0.0±0.0	0.5±1.1	2.0±2.5	98.0±3.4	100.0±0.0	99.5±1.1	100.0±0.0	100.0±0.0

Table 3.3: The results for each subject for side-by-side slots with visual and haptic cues.

all the subjects and its range for 95% confidence in the results is shown in figure 3-11.

### 3.4.5 Experiments for Side-by-Side Slots with Haptic Cues Only

The results for this experiment are listed in table 3.7. The values for each subject have been averaged over the 20 trials in each condition. The plot for the average over all the subjects and its range for 95% confidence in the results is shown in figure 3-12.

### 3.4.6 Experiments for Rear-and-Front Slots with Haptic Cues Only

The results for this experiment are listed in table 3.8. The values for each subject have been averaged over the 20 trials in each condition. The plot for the average over all the subjects and its range for 95% confidence in the results is shown in figure 3-13.

%Response the Variable Slot perceived Longer(in %)								
S	-20%	-10%	-5%	5%	10%	20%	30%	40%
1	25	35	45	80	85	100	100	100
2	5	10	40	80	100	95	100	95
3	10	30	50	85	100	100	100	100
4	0	0	5	30	40	80	90	100
5	0	0	0	5	30	55	80	100
6	0	5	15	55	80	100	100	100
7	5	10	10	20	15	45	60	80
8	5	15	20	50	25	70	65	90
9	0	5	5	30	45	65	90	85
10	5	0	25	25	25	55	75	95
Av	5.5±5.4	11.0±8.8	21.5±12.8	46.0±20.2	54.5±23.7	76.5±15.2	86.0±10.9	94.5±5.1

Table 3.4: The results for each subject for rear-and-front slots with visual and haptic cues.

%Response the Variable Slot perceived Longer(in %)								
S	-20%	-10%	-5%	5%	10%	20%	30%	40%
1	0	0	0	100	100	100	100	100
2	0	0	0	100	100	100	100	100
3	0	0	0	100	100	100	100	100
4	0	0	0	100	100	100	100	100
5	0	0	0	100	100	100	100	100
6	0	0	0	100	100	100	100	100
7	0	0	5	100	100	100	100	100
8	0	0	0	100	95	100	100	100
9	0	0	5	100	100	100	100	100
10	0	0	0	100	100	100	100	100
Av	0.0±0.0	0.0±0.0	1.0±1.5	100.0±0.0	99.5±1.1	100.0±0.0	100.0±0.0	100.0±0.0

Table 3.5: The results for each subject for side-by-side slots with visual cues only.

%Response the Variable Slot perceived Longer(in %)								
S	-20%	-10%	-5%	5%	10%	20%	30%	40%
1	0	10	5	55	75	95	100	95
2	0	0	0	25	60	100	100	100
3	0	0	0	15	25	75	95	100
4	0	0	0	10	15	45	100	100
5	0	0	0	0	10	60	95	100
6	0	0	0	5	50	85	100	100
7	0	5	25	95	90	100	100	100
8	0	5	0	0	30	45	70	95
9	0	0	0	0	0	5	50	70
10	0	5	0	25	35	90	100	100
Av	0.0±0.0	2.5±2.5	3.0±5.6	23.0±21.8	39.0±20.9	70.0±22.1	91.0±12.2	96.0±6.7

Table 3.6: The results for each subject for rear-and-front slots with visual cues only.

%Response the Variable Slot perceived Longer(in %)								
S	-20%	-10%	-5%	5%	10%	20%	30%	40%
1	0	5	15	70	75	100	100	100
2	0	0	0	30	25	80	100	100
3	0	5	20	75	75	95	100	95
4	15	25	55	85	80	95	100	100
5	0	5	20	55	90	100	100	100
6	0	5	15	65	90	100	100	100
7	0	10	50	50	75	90	100	100
8	0	0	0	100	95	100	100	100
9	10	30	50	55	90	90	95	100
10	5	5	20	55	55	85	90	95
Av	3.0±3.8	9.0±7.3	24.5±14.4	64.0±14.0	75.0±15.0	93.5±5.0	98.5±2.4	99.0±1.5

Table 3.7: The results for each subject for side-by-side slots with haptic cues only.

%Response the Variable Slot perceived Longer(in %)								
S	-20%	-10%	-5%	5%	10%	20%	30%	40%
1	5	15	40	70	85	95	100	100
2	0	10	35	65	80	100	100	100
3	15	35	60	80	90	100	100	100
4	10	55	50	80	65	85	90	100
5	0	0	5	35	40	70	95	100
6	0	5	25	80	90	100	100	100
7	0	25	20	55	70	90	95	95
8	0	5	0	0	30	45	70	95
9	5	5	45	35	75	75	90	95
10	5	45	55	65	60	90	95	100
Av	4.0±3.6	20.0±13.6	33.5±14.7	56.5±18.6	68.5±14.6	85.0±12.5	93.5±6.5	98.5±1.7

Table 3.8: The results for each subject for rear-and-front slots with haptic cues only.

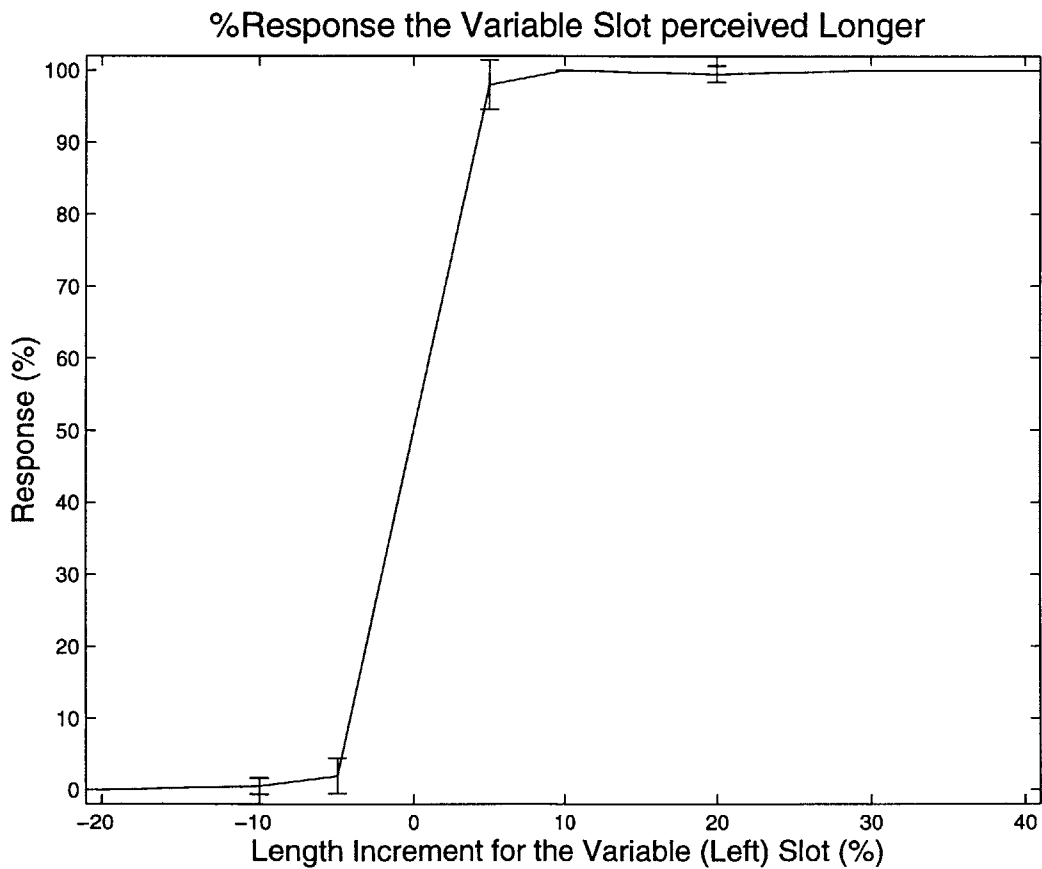

Figure 3-8: The average results for side-by-side slots with visual and haptic cues.

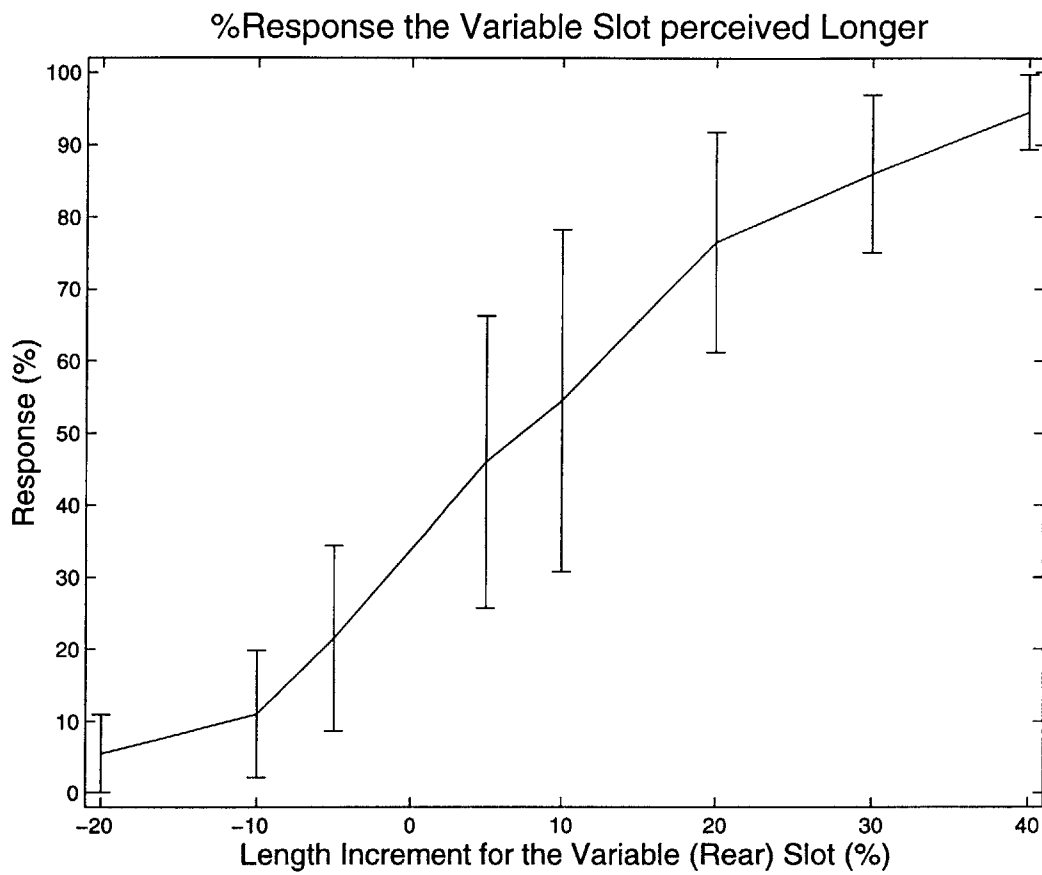

Figure 3-9: The average results for rear-and-front slots with visual and haptic cues.

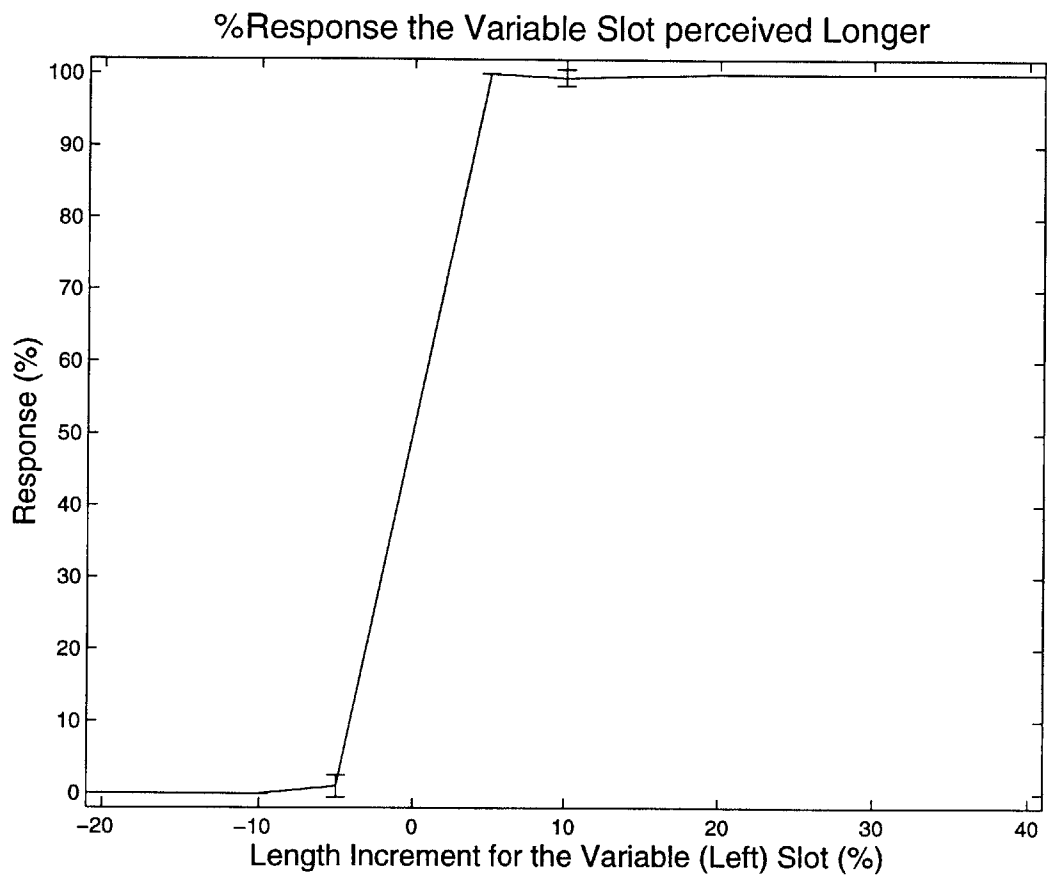

Figure 3-10: The average results for side-by-side slots with visual cues only.



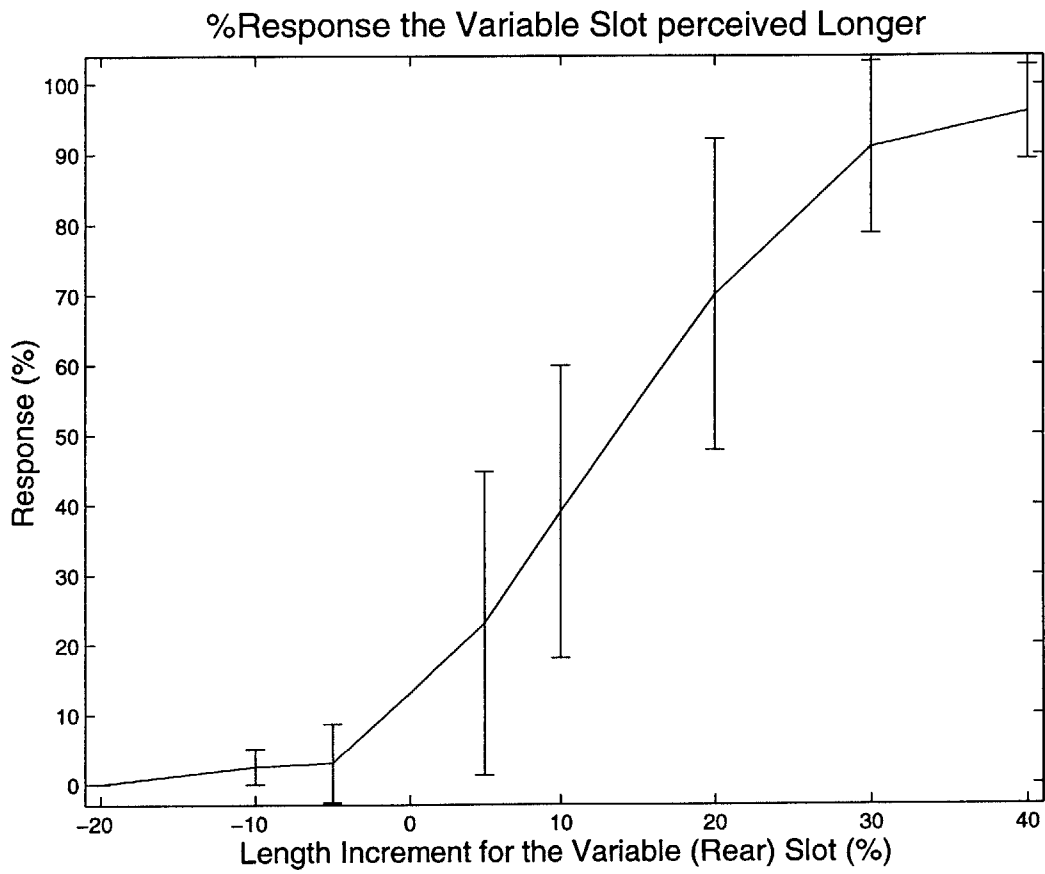

Figure 3-11: The average results for rear-and-front slots with visual cues only.

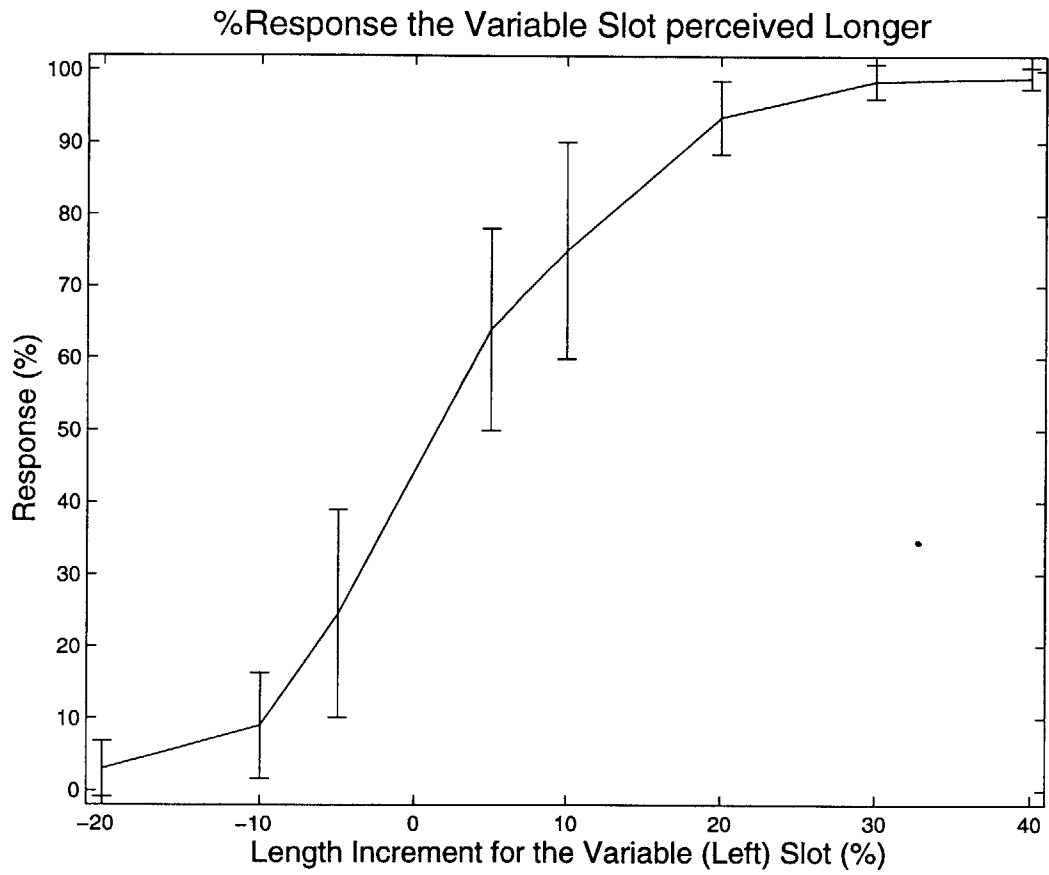

Figure 3-12: The average results for side-by-side slots with haptic cues only.

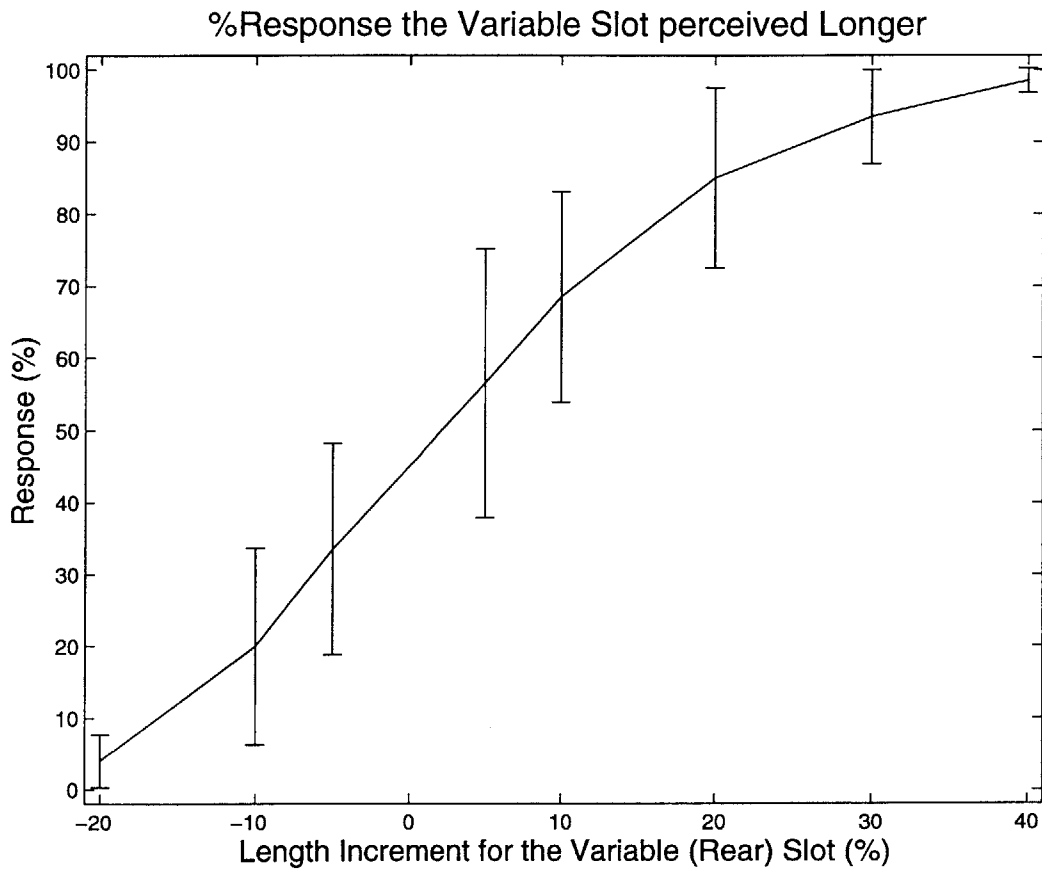

Figure 3-13: The average results for rear-and-front slots with haptic cues only.

# Chapter 4

## Stiffness Discrimination

### Experiments

#### 4.1 Experimental Goal

Experiments were designed to investigate the effect of visual perspective on the visual and haptic perception of object stiffness. Due to 3D perspective graphics, a compliant object that is farther from us appears to deform less than when it is nearer to us, under the same force. The purpose is to investigate if it would be perceived as softer/stiffer when its stiffness characteristics are explored via a haptic device with or without accompanying visual display.

#### 4.2 Experimental Design

##### 4.2.1 Apparatus

The experimental setup was the same as described in section 3.2.1.

##### 4.2.2 Spring Buttons

The stimuli were a pair of virtual buttons, which were placed either side-by-side (S-S) or rear-and-front (R-F) (figure 4-1). They were graphically displayed on a monitor

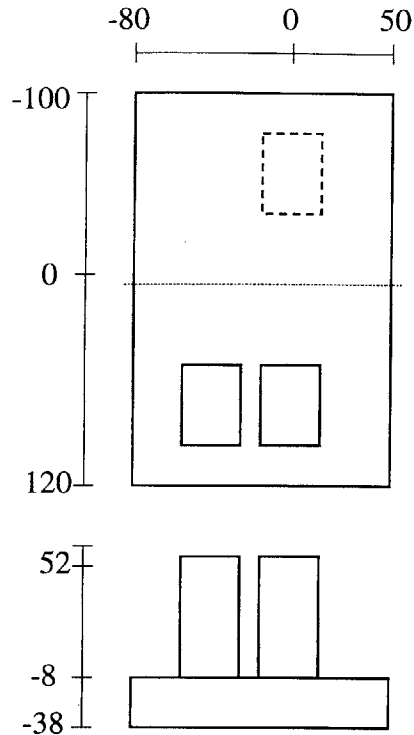

Figure 4-1: The configuration of the button sets (mm).

screen in perspective projection (figure 4-2). When the subjects pressed a virtual button with the stylus of the PHANToM, the button deformed the same amount as the displacement of the tip of the cursor. During the experiment, the stiffness of the left (or rear) button was kept fixed, referred to as the standard button; the stiffness of the right (or front) button, referred to as the variable button, varied as 0.7, 0.8, 0.9, 1.0, 1.1, 1.2, and 1.3 times that of the standard one. The details of variations in stiffness are listed in table 4.2.2. The stiffness of the variable button was altered from trial to trial in random order. However, the sequence of stimuli that were displayed to each subject was the same.

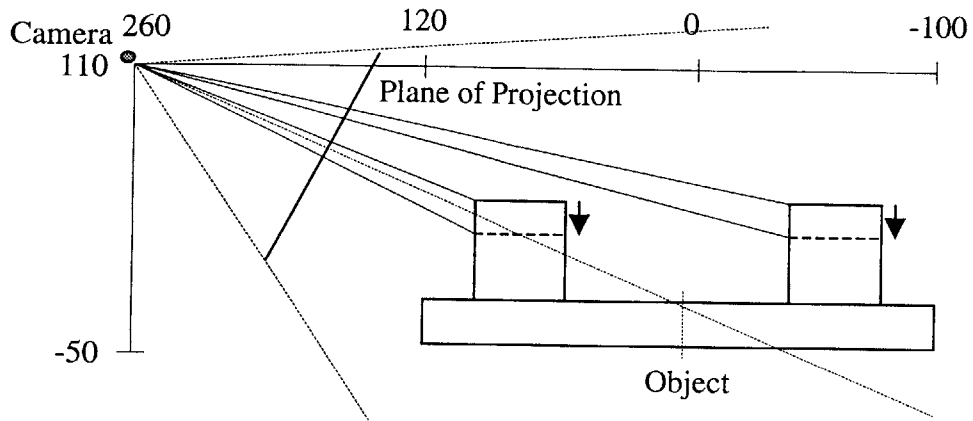

Figure 4-2: The perspective display parameters for the button sets (mm).

Stiffness Ratio	Side by Side (S-S)		Rear and Front (R-F)	
	Left(N/mm)	Right(N/mm)	Rear(N/mm)	Front(N/mm)
0.7	0.20	0.14	0.20	0.14
0.8	0.20	0.16	0.20	0.16
0.9	0.20	0.18	0.20	0.18
1.0	0.20	0.20	0.20	0.20
1.1	0.20	0.22	0.20	0.22
1.2	0.20	0.24	0.20	0.24
1.3	0.20	0.26	0.20	0.26

Table 4.1: The stiffness variation of the buttons.

## 4.3 Experimental Procedure

Ten right handed subjects aged 18 – 30 participated in these experiments. All of them had previously participated in several other experiments using the PHANToM. Because this experiment involved dynamically pressing virtual objects, their previous experience was beneficial in reducing any effects resulting from the unease in using the PHANToM. Before each session, the subject was asked to read the instructions for the experiment and sign a consent form for participating in the experiment. A practice session lasting 15 minutes was offered to make sure that the subjects understood the experimental procedure. At the start of each block of trials, the subject was asked to center the stylus of PHANToM to ensure the same starting position for each trial. At the end of the experiments, the subjects were encouraged to describe the strategy they used in performing the assigned task.

The subjects came to participate in the experiment only once for about an hour and a half within which there were two sessions as described below. As shown in table 4.2.2, there were totally 28 stimulus conditions (7 variations in the variable button stiffness, 2 button pair configurations (S-S, R-F), and 2 display cases (visual + haptic and haptic only)), with 12 trials for each stimulus condition.

### 4.3.1 Experiments with Both Visual and Haptic Cues

In the first session, the subjects were asked to view the 3D graphics on the screen (figure 4-3) and manipulate the stylus to judge which button was softer. A visual cursor was displayed to help the subject navigate in the 3D virtual world and explore the buttons easily. They pressed “1” on the keyboard to pick the left (or rear) one, or “2” to pick the right (or front) one, as shown on the screen. There were totally 10 blocks, with the odd numbered blocks representing the S-S case, and the even numbered blocks representing the R-F case.

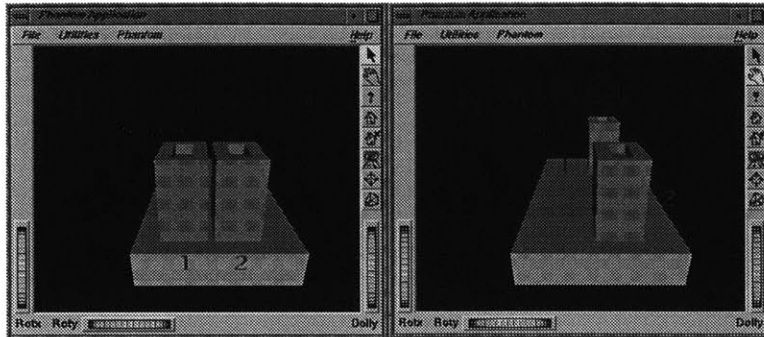

Figure 4-3: The 3D graphics shown for visual and haptic cues experiments.

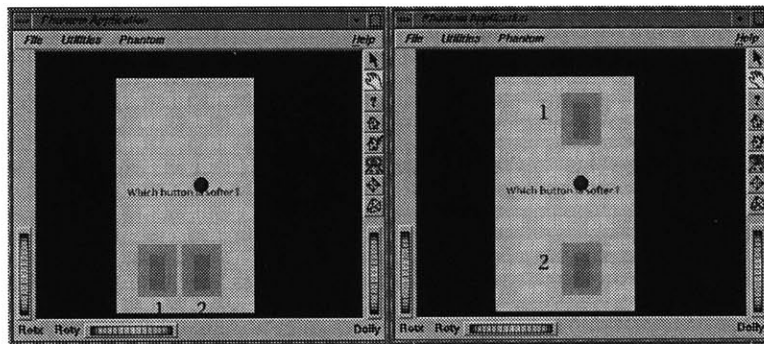

Figure 4-4: The 2D top-view shown for haptic cues only experiments.

### 4.3.2 Experiments with Haptic Cues Only

In the second session, the subjects were asked to view the top-view (2D) graphics on the screen (figure 4-4) and move the stylus judge which button was softer. They pressed either “1” (left, rear) or “2” (right, front) on the keyboard, as shown on the screen. In this session, the subjectd had no visual information about the compliance of the buttons, so it was a haptic cues only condition.



## **4.4 Experimental Results**

### **4.4.1 Experiments for Side-by-Side Buttons with Both Visual and Haptic Cues**

The results for this experiment are listed in table 4.2. The values for each subject have been averaged over the 12 trials in each condition. The plot for the average over all the subjects and its range for 95% confidence in the results is shown in figure 4-5.

### **4.4.2 Experiments for Rear-and-Front Buttons with Both Visual and Haptic Cues**

The results for this experiment are listed in table 4.3. The values for each subject have been averaged over the 12 trials in each condition. The plot for the average over all the subjects and its range for 95% confidence in the results is shown in figure 4-6.

### **4.4.3 Experiments for Side-by-Side Buttons with Haptic Cues Only**

The results for this experiment are listed in table 4.4. The values for each subject have been averaged over the 12 trials in each condition. The plot for the average over all the subjects and its range for 95% confidence in the results is shown in figure 4-7.

### **4.4.4 Experiments for Rear-and-Front Buttons with Haptic Cues Only**

The results for this experiment are listed in table 4.5. The values for each subject have been averaged over the 12 trials in each condition. The plot for the average over all the subjects and its range for 95% confidence in the results is shown in figure 4-8.

%Response the Variable Button perceived Softer(in %)							
	0.7	0.8	0.9	1.0	1.1	1.2	1.3
S1	100.00	100.00	75.00	33.33	0.00	8.33	0.00
S2	100.00	100.00	91.67	58.33	0.00	0.00	0.00
S3	100.00	100.00	100.00	75.00	0.00	0.00	0.00
S4	100.00	91.67	100.00	66.67	33.33	16.67	8.33
S5	100.00	100.00	100.00	6.67	0.00	0.00	0.00
S6	100.00	100.00	100.00	33.33	8.33	0.00	0.00
S7	100.00	100.00	100.00	66.67	0.00	0.00	0.00
S8	100.00	91.67	91.67	41.67	8.33	0.00	0.00
S9	100.00	100.00	91.67	33.33	0.00	0.00	0.00
S10	100.00	100.00	100.00	41.67	0.00	8.33	0.00
Ave	100.0±0.0	98.3±2.5	95.0±5.7	45.6±14.9	5.0±7.5	3.3±4.1	0.8±1.8

Table 4.2: The results for each subject for side-by-side buttons with visual and haptic cues.

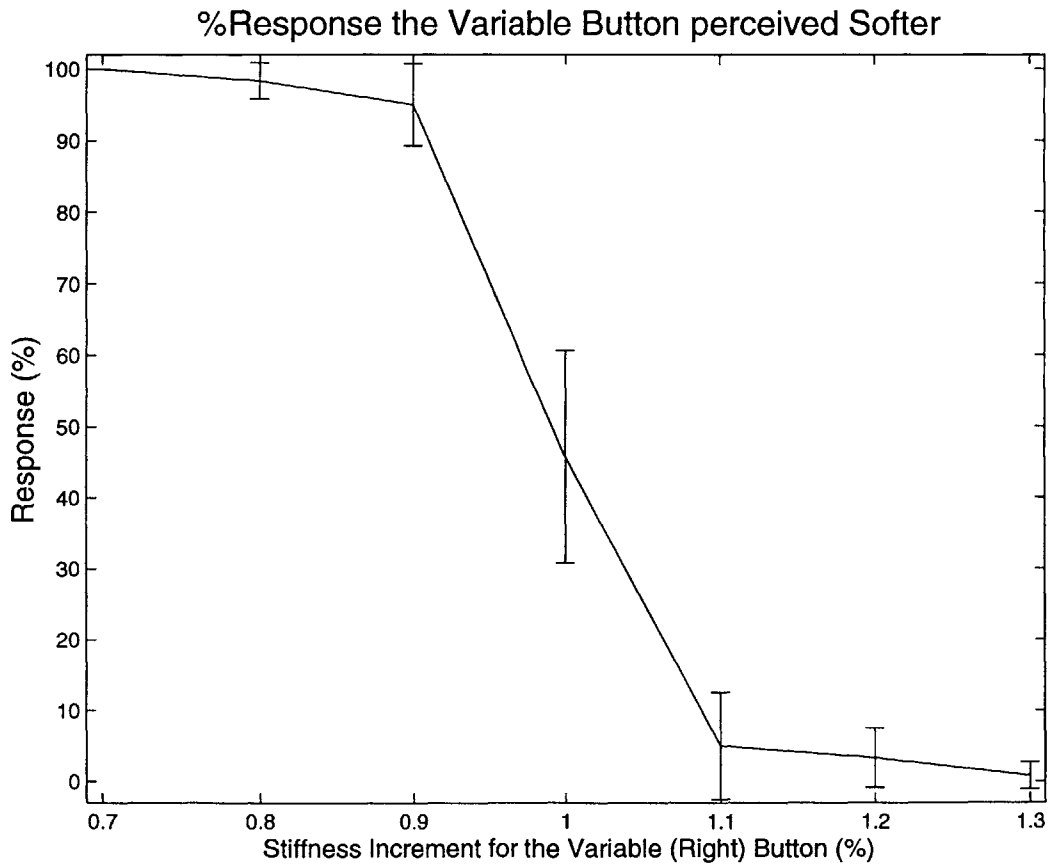

Figure 4-5: The results for side-by-side buttons with visual and haptic cues.

%Response the Variable Button perceived Softer(in %)							
	0.7	0.8	0.9	1.0	1.1	1.2	1.3
S1	100.00	100.00	91.67	66.67	25.00	0.00	0.00
S2	100.00	100.00	75.00	8.33	8.33	0.00	0.00
S3	100.00	100.00	91.67	50.00	16.67	0.00	0.00
S4	100.00	100.00	91.67	50.00	8.33	0.00	0.00
S5	100.00	100.00	83.33	33.33	0.00	8.33	0.00
S6	100.00	100.00	100.00	91.67	33.33	0.00	0.00
S7	100.00	100.00	100.00	41.67	8.33	0.00	0.00
S8	100.00	100.00	100.00	91.67	75.00	33.33	33.33
S9	100.00	100.00	91.67	41.67	0.00	0.00	0.00
S10	100.00	100.00	100.00	41.67	0.00	8.33	0.00
Ave	100.0±0.0	100.0±0.0	92.5±5.9	51.6±18.3	17.5±16.4	5.0±7.5	3.3±7.5

Table 4.3: The results for each subject for rear-and-front buttons with visual and haptic cues.

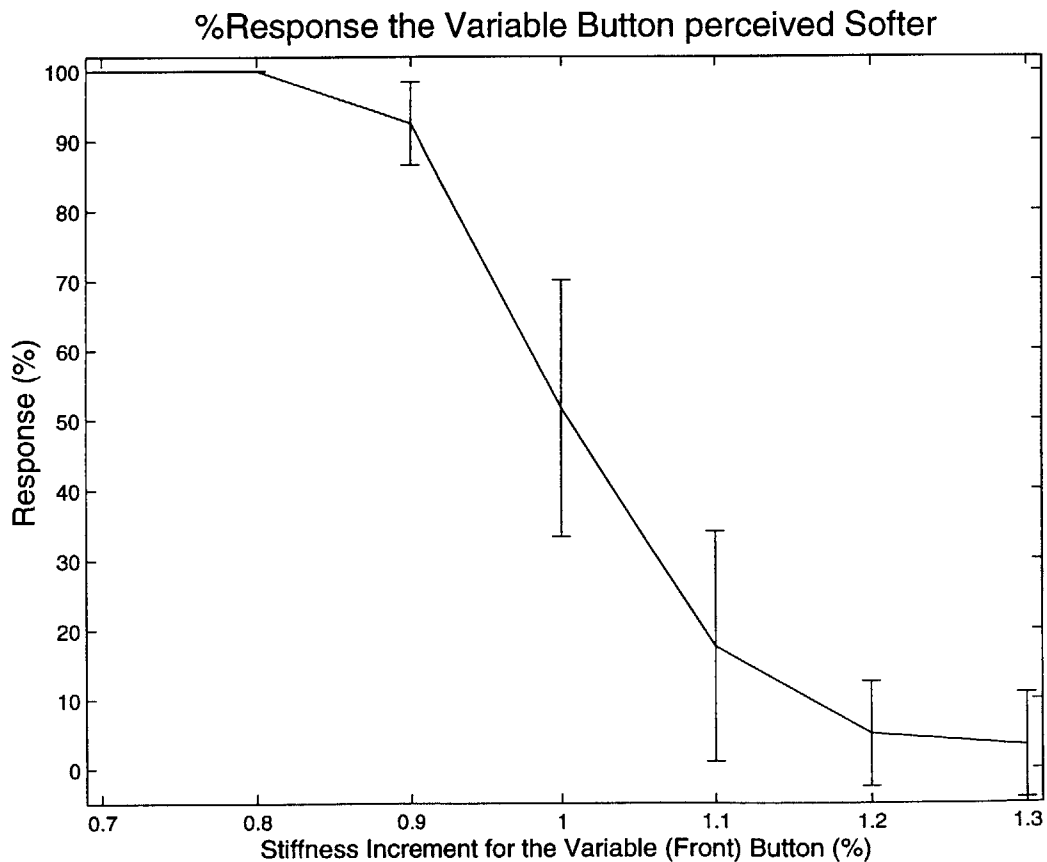

Figure 4-6: The results for rear-and-front buttons with visual and haptic cues.

%Response the Variable Button perceived Softer(in %)							
	0.7	0.8	0.9	1.0	1.1	1.2	1.3
S1	100.00	100.00	75.00	50.00	0.00	0.00	0.00
S2	100.00	100.00	91.67	33.33	0.00	0.00	0.00
S3	100.00	100.00	100.00	75.00	8.33	0.00	0.00
S4	100.00	100.00	100.00	83.33	25.00	8.33	8.33
S5	100.00	100.00	100.00	91.67	16.67	0.00	0.00
S6	100.00	91.67	58.33	16.67	8.33	0.00	0.00
S7	100.00	100.00	100.00	100.00	58.33	0.00	0.00
S8	100.00	100.00	91.67	58.33	58.33	8.33	8.33
S9	100.00	100.00	100.00	83.33	0.00	8.33	0.00
S10	100.00	100.00	58.33	16.67	0.00	0.00	0.00
Ave	100.0±0.0	99.1±1.8	87.5±12.3	60.8±21.9	17.5±16.4	2.5±2.8	1.6±2.5

Table 4.4: The results for each subject for side-by-side buttons with haptic cues only.

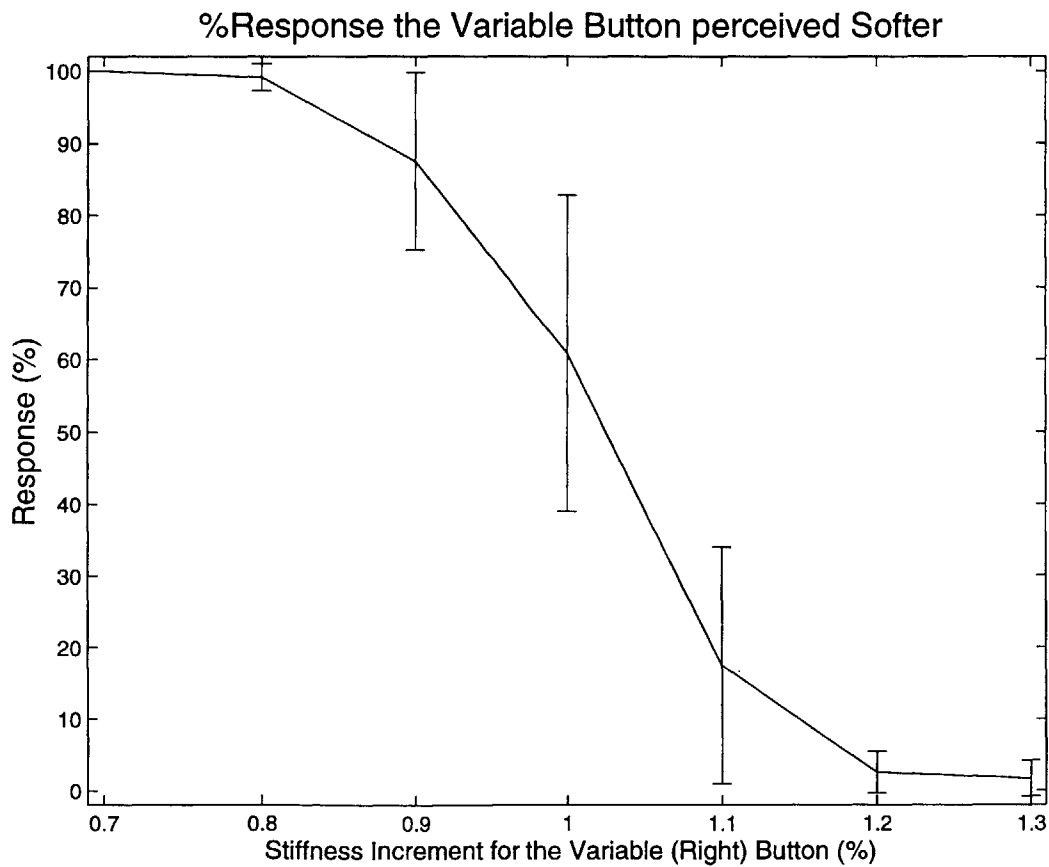

Figure 4-7: The results for side-by-side buttons with haptic cues only.

%Response the Variable Button perceived Softer(in %)							
	0.7	0.8	0.9	1.0	1.1	1.2	1.3
S1	100.00	91.67	33.33	8.33	0.00	0.00	0.00
S2	91.67	41.67	50.00	0.00	0.00	0.00	0.00
S3	100.00	100.00	100.00	91.67	41.67	0.00	0.00
S4	100.00	50.00	16.67	0.00	8.33	0.00	0.00
S5	100.00	91.67	8.33	0.00	0.00	0.00	0.00
S6	100.00	100.00	100.00	66.67	25.00	25.00	0.00
S7	100.00	91.67	58.33	0.00	0.00	0.00	0.00
S8	91.67	58.33	41.67	50.00	41.67	0.00	8.33
S9	100.00	91.67	41.67	8.33	8.33	0.00	0.00
S10	83.33	50.00	25.00	0.00	8.33	0.00	0.00
Ave	96.6±4.1	76.6±16.8	47.5±22.4	22.5±24.3	13.3±11.9	2.5±5.6	0.8±1.8

Table 4.5: The results for each subject for rear-and-front buttons with haptic cues only.

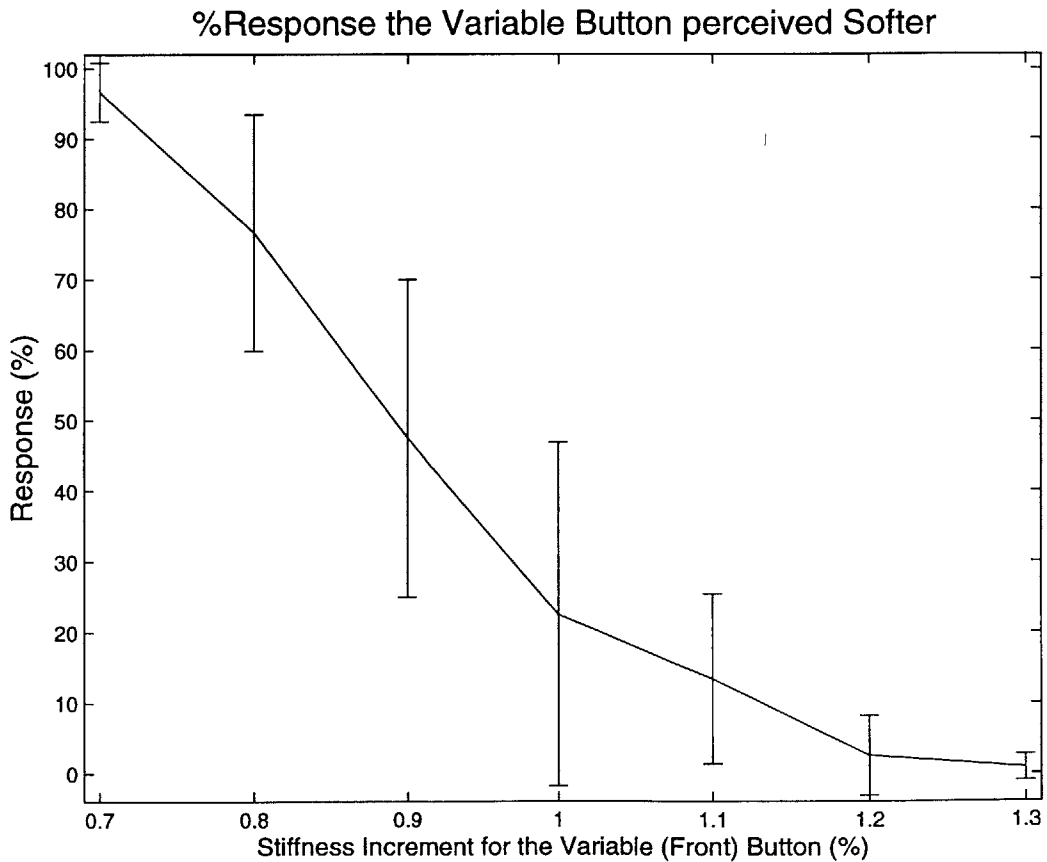

Figure 4-8: The results for rear-and-front buttons with haptic cues only.

# Chapter 5

## Discussion on Size and Stiffness Discrimination Experiments

### 5.1 Size Discrimination Experiments

From the results listed and plotted in section 3.4, we can see that in the experiments providing both visual and haptic cues, the subjects' ability to discriminate the slot lengths was very close to the expected results when the subject has perfect resolution without perceptual bias (as in figure 5-1) in the S-S case, with very small differences between subjects (figure 3-8). However, the subjects' performance was not so close to the ideal in the R-F case, with larger differences between subjects (figure 3-9).

In the experiments in which only visual cues were provided, the trend was even more obvious (figures 3-10 and 3-11): the average results in S-S case were even more close to the ideal, with very small differences between subjects, and the average results in R-F case deviated considerably from the ideal, with even larger differences between subjects.

In the experiments in which only haptic cues were provided, the results for both S-S and R-F cases were not close to the ideal, with approximately the same amount of deviation (figures 3-12 and 3-13).

These results are replotted in the following sections for comparison and discussion. The average values are shown by the solid curves and in some plots the range of data

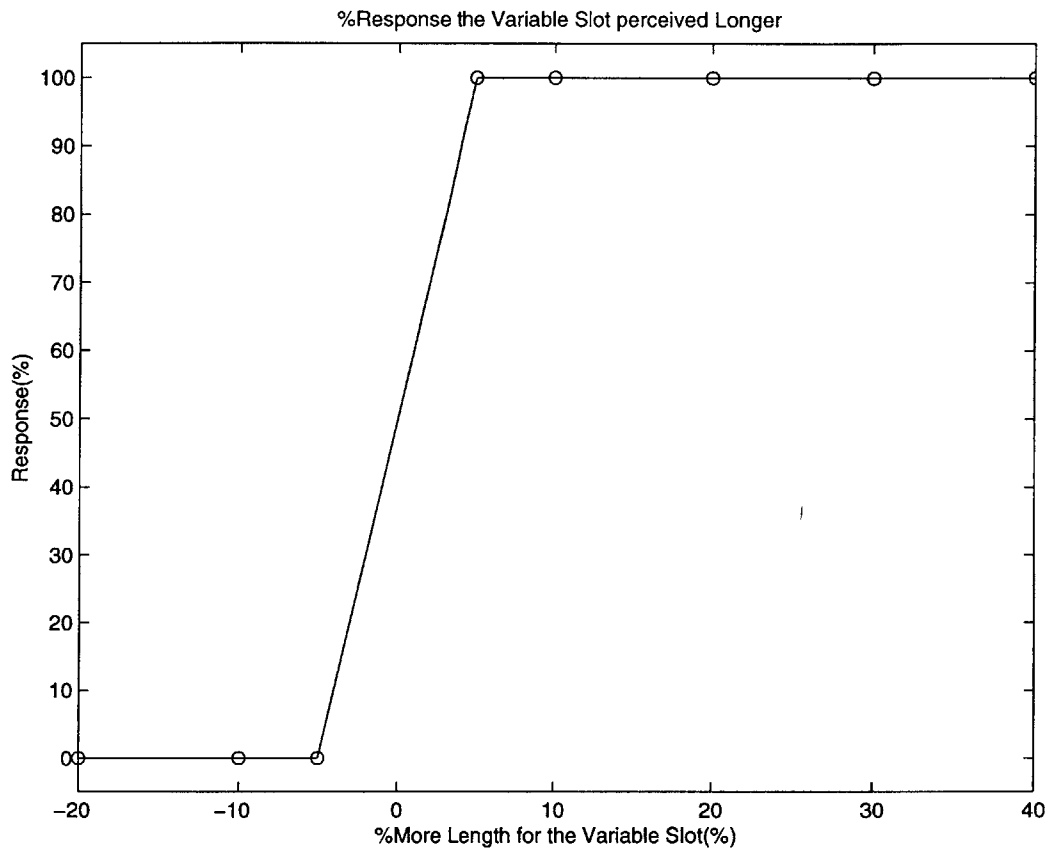

Figure 5-1: The expected result corresponding to perfect discrimination in both S-S and R-F cases.

for 95% confidence level are represented by the short vertical bars (plotted on only one side of the curves for clarity), with the ideal curve (figure 5-1) shown for comparison.

### **5.1.1 The Performance when Only Visual Cues were Provided**

We can see from figure 5-2 that under the visual cues only condition, the subjects' performance was very close to the ideal curve for the S-S configuration. However, the results deviate from the ideal curve for the R-F configuration and indicate the presence of a bias as well as a decrease in resolution. For example, the 50% response (i.e. PSE: Point of Subjective Equality) in figure 5-2 corresponds to the variable slot being about 14% longer than the standard slot. It means that when only visual cues were provided and the actual length of the rear slot was about 1.14 times the length of the front one, the two slots were perceived to be of the same size, i.e. a visual bias of 14%. This result clearly shows that farther objects are perceived to be shorter when only visual feedback is available. Moreover, the length increment of the variable slot that is discriminable from the standard one is  $> 22\%$  for longer variable slots (corresponding to 75% response) and  $< 6\%$  for shorter variable slots (corresponding to 25% response). By subtracting the visual bias of 14% at PSE, we can infer a visual resolution of  $\pm 8\%$ .

### **5.1.2 The Performance when Only Haptic Cues were Provided**

For the haptic cues only condition, the results do not show any haptic bias since the length increment for the variable slot is almost zero at the PSE for both S-S and R-F configurations (figure 5-3). However, the haptic resolution is, on the average, poorer than the visual resolution for each of the two slot configurations: about 5 to 10% for S-S and 9 to 14% for R-F.



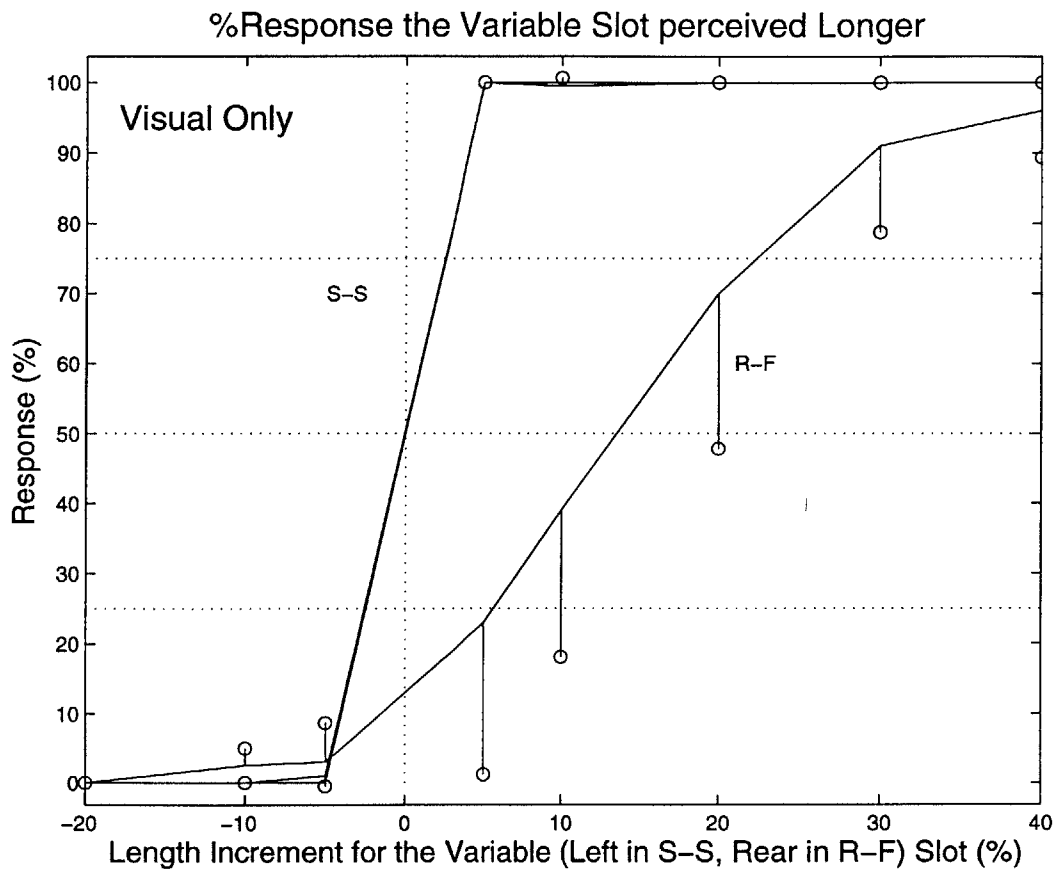

Figure 5-2: The results when only visual cues were provided.

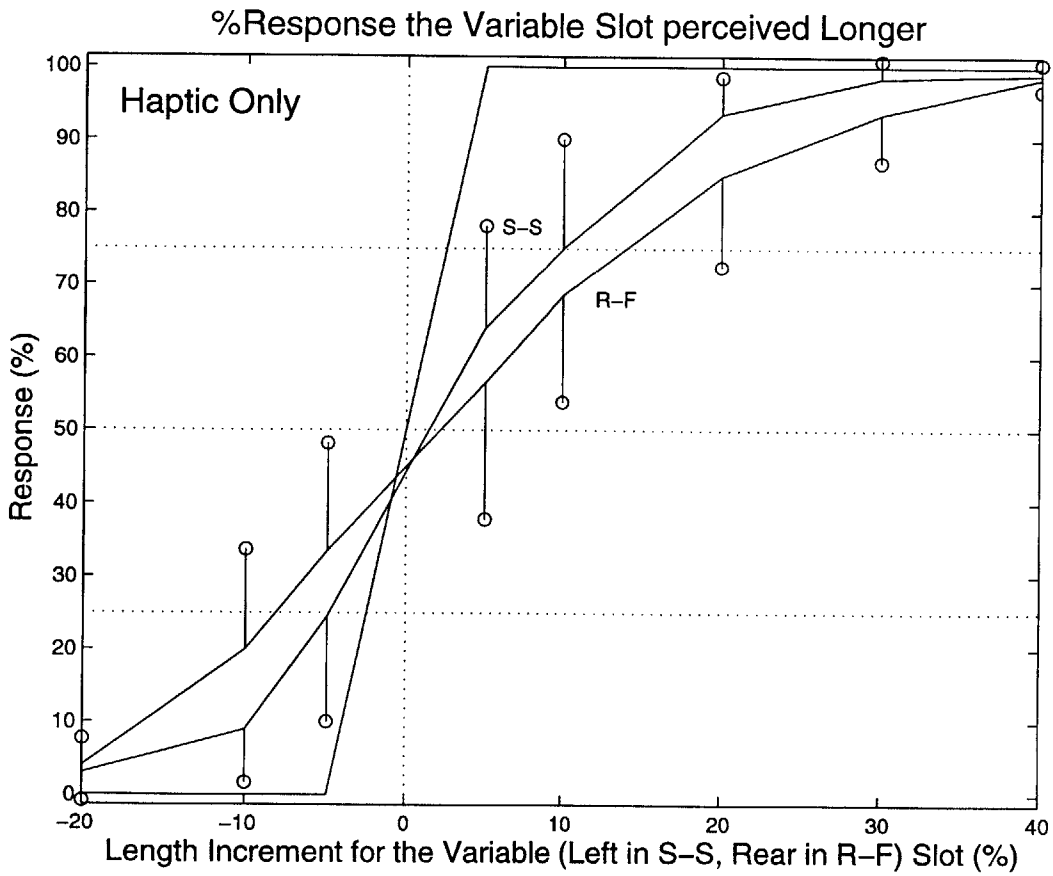

Figure 5-3: The results when only haptic cues were provided.

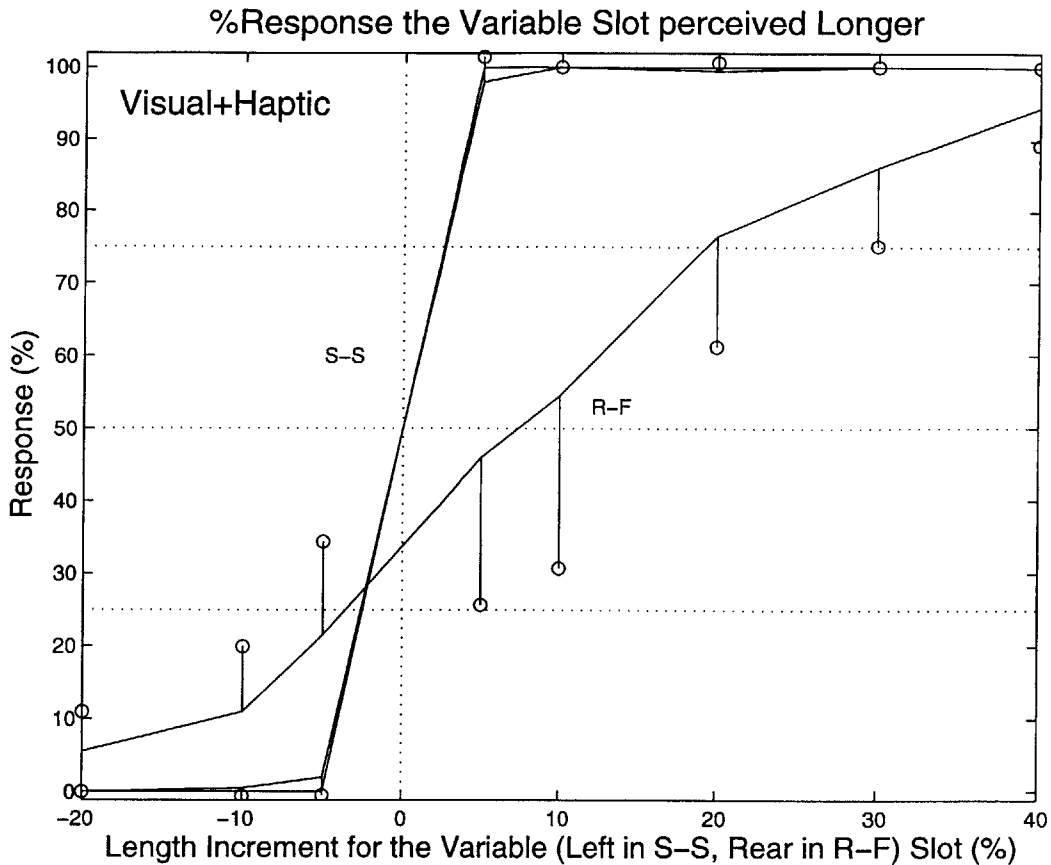

Figure 5-4: The results when both visual and haptic cues were provided.

### 5.1.3 The Performance when Both Visual and Haptic Cues were Provided

The results when both visual and haptic cues were provided (figure 5-4) suggest that there is some form of sensory fusion: the performance in S-S configuration is about the same as that for visual only case which is better than that for the haptic only case; the performance in R-F has a reduced bias of 8% compared to the visual only case, but a poorer resolution of around 12%. These results are better shown in figures 5-5 and 5-6, where the results for the visual + haptic condition are between the haptic only and visual only curves. In other words, visual and haptic modalities of our sensory system seem to work together along the direction of gaze (the direction in which the perspective effects are dominant) in perceiving object size.

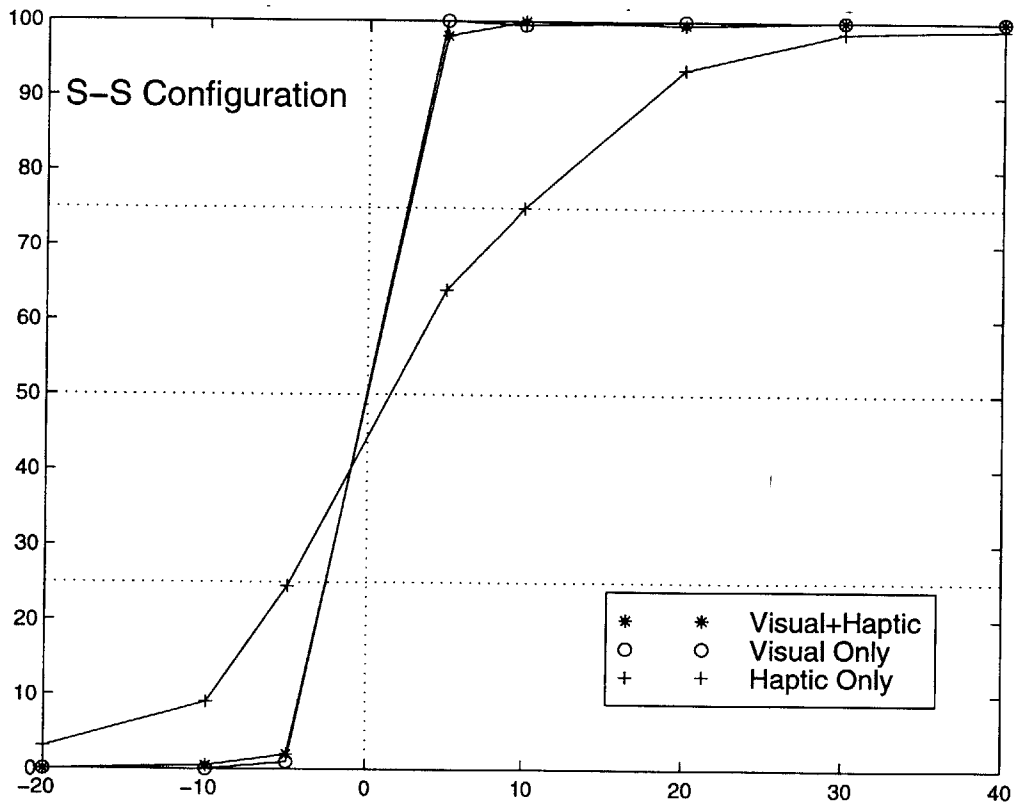

Figure 5-5: The results for the side-by-side case.

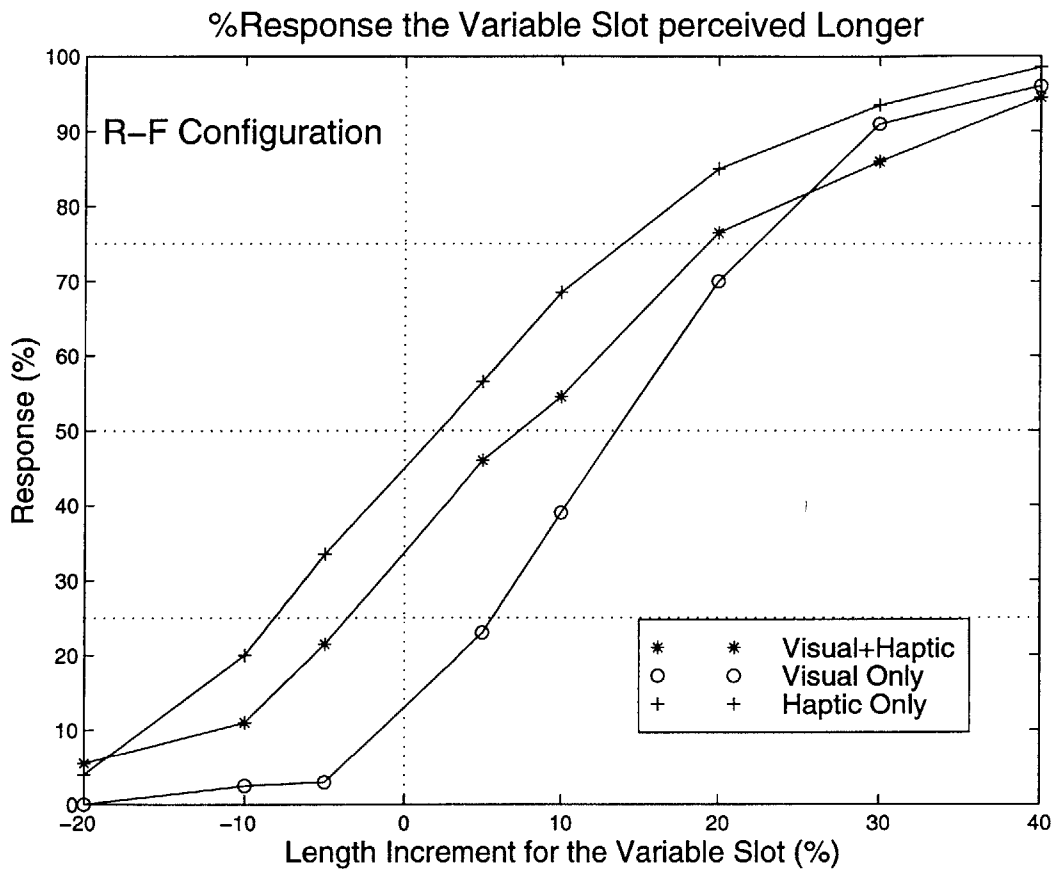

Figure 5-6: The results for the rear-and-front case.

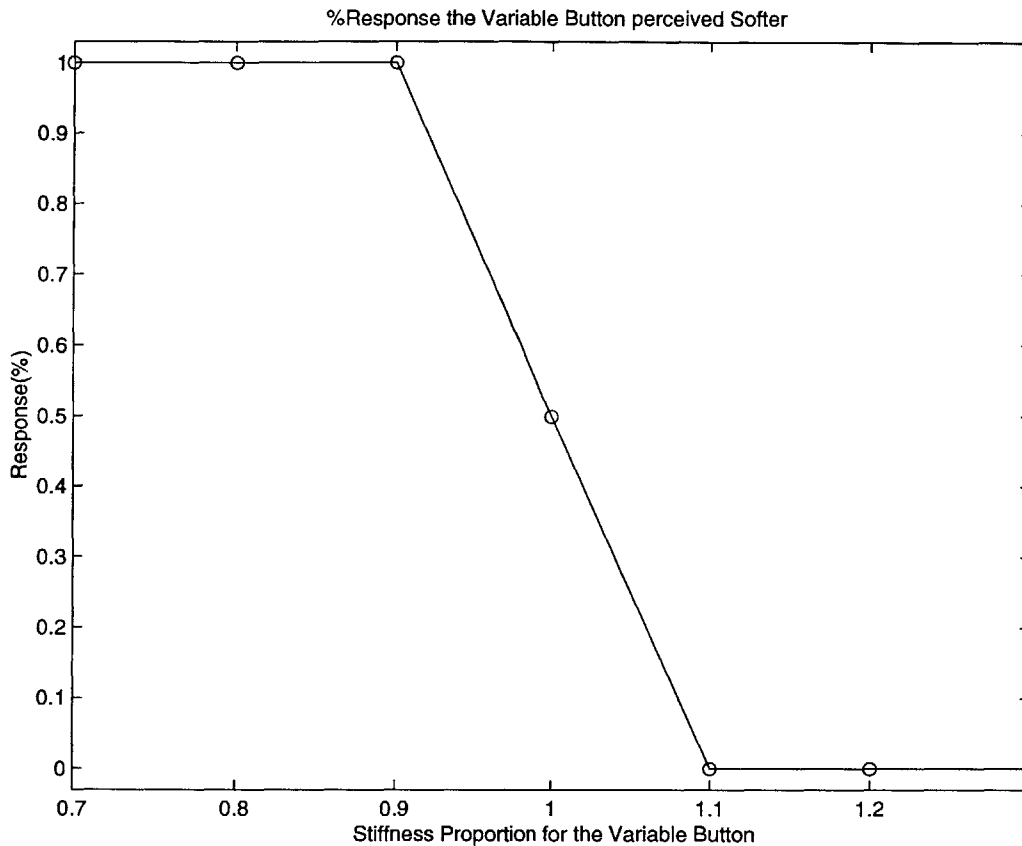

Figure 5-7: The expected results corresponding to perfect discrimination performance.

## 5.2 Stiffness Discrimination Experiments

The results described in section 4.4 are replotted in the following sections for comparison and discussion. The average values are shown by the solid curve and in some plots, the range of data for 95% confidence level are represented by the vertical solid bars (plotted on only one side of the curves for clarity). Where appropriate, the ideal curve (figure 5-7) is also shown for comparison.

In the stiffness discrimination experiments, when only haptic cues were available (HO condition), for the S-S configuration the bias is approximately zero and the resolution is about 6 to 8%. In the R-F configuration, the subjects felt the rear button to be haptically softer than the front one. This effect can be seen in the curve for the R-F configuration in figure 5-8: when the stiffness coefficient of the variable button (the front one) is the same as the standard one (the rear one), the rear button is perceived to be softer in about 80% of the trials. As determined by the PSE, the

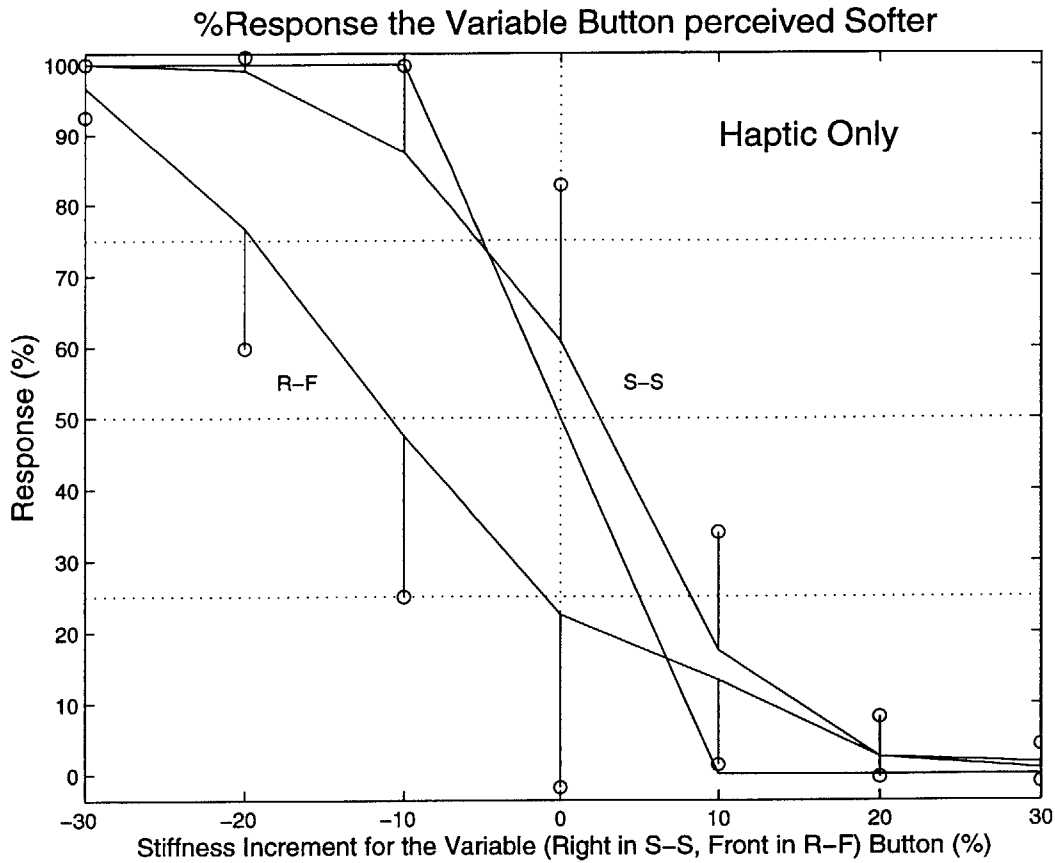

Figure 5-8: The results when only haptic cues were provided (with 2D visual cues).

haptic bias for the R-F configuration is approximately  $-10\%$  and the resolution is about  $10\%$  under the HO condition. This bias disappears and the resolution improves to about  $5\%$  for both S-S and R-F configurations when visual cues are added to the scene (see figure 5-9).

From figure 5-11, we can also see that the effect of the visual feedback on the R-F configuration is to shift the R-F curve to the right (i.e. reduction of bias) and make it steeper (i.e. better resolution). This results in the standard button (the rear one) being perceived as stiffer. It should be noted that there is no significant difference between the curves corresponding to S-S and R-F configurations when visual and haptic cues are both available to the subjects (figure 5-9).

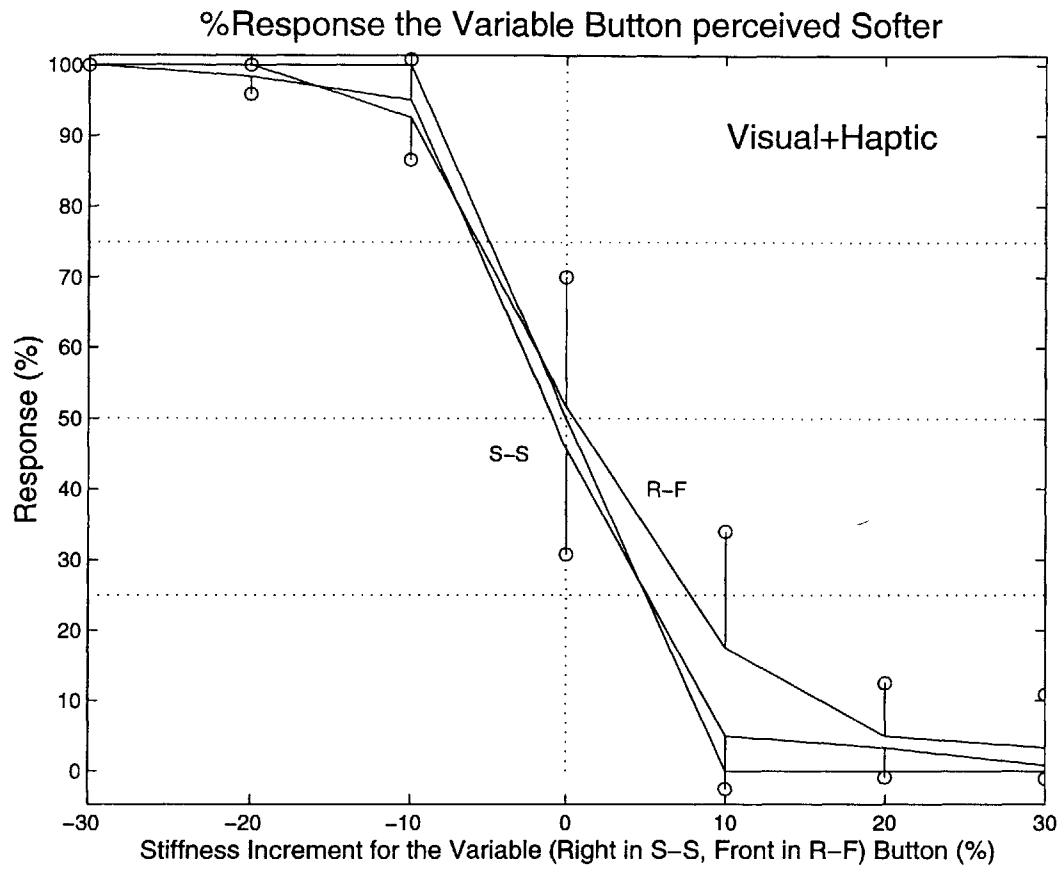

Figure 5-9: The results when both visual and haptic cues were provided (with 3D visual cues).



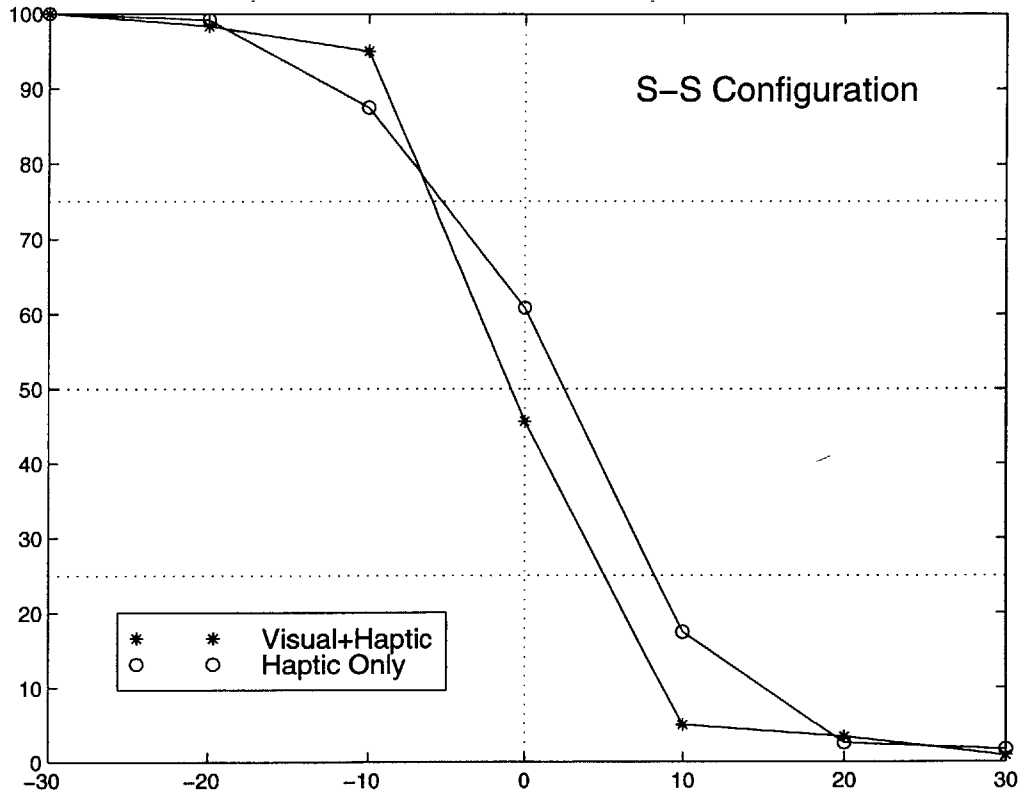

Figure 5-10: The results for the side-by-side case.

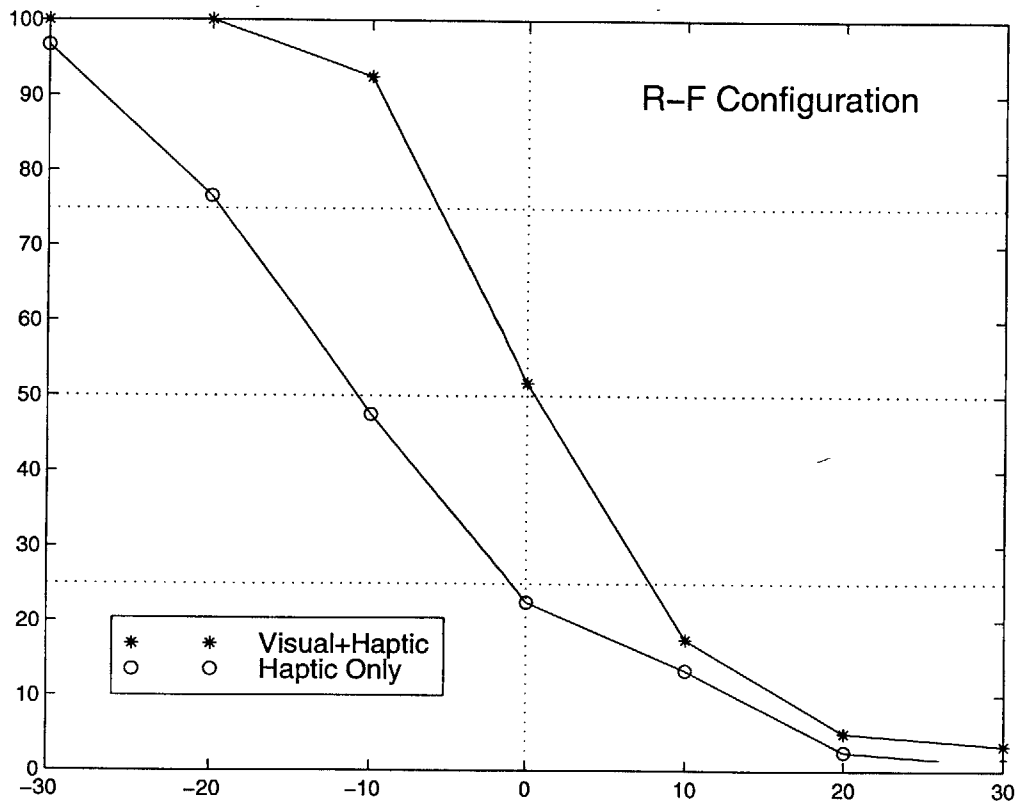

Figure 5-11: The results for the rear-and-front case.

## 5.3 Conclusions

The results of the experiments described here show that the 3D perspective visual displays in VEs indeed generate visual and haptic illusions due to biases in perception such that the farther objects are perceived to be (1) shorter in length when there are only visual cues and (2) softer when there are only haptic cues. However, when both sensory cues are provided, sensory data is fused such that vision and touch compensate for bias due to each other.

The results displayed in figure 5-6 can be interpreted in terms of the relative roles played by vision and haptics as follows. For each length increment of the variable slot, the difference in the response (%) between the visual + haptic case and the visual only case can be thought of as the effect of haptics on vision. Similarly, the difference in response (%) between haptic only and visual + haptic cases can be thought of as the effect of vision on haptics. Normalizing the sum of the values to 100%, we obtain the bar graph shown in figure 5-12. We only plot the range from  $-10\%$  to  $+20\%$  because it seems that outside this region, due to obvious differences in the lengths of slots, the judgment is not a typical compromise between the two senses. In figure 5-12, we can see that as the lengths of the two slots presented to the subjects get closer, the subjects rely more on haptic information which has no bias (figure 5-3).

In particular, the result that the farther objects are perceived to be softer when only haptic cues are present is interesting and perhaps suggests a new concept of *haptic perspective*. To ensure that this result was not an artifact of the robot arm (i.e. position and force errors due to the kinematics of the haptic device) or our experimental design, we performed three different tests, but the result did not change. The haptic device was rotated 90 degrees and the experiment was repeated for both S-S and R-F configurations. The calibration of the device was checked by hanging known weights and by measuring the displacement of the stylus. Force and displacement data showed perfect agreement. To further verify the results, the left and rear buttons were designated as the variable button and the experiments were repeated for S-S and R-F configurations, respectively. Based on the fact that these tests did not change the

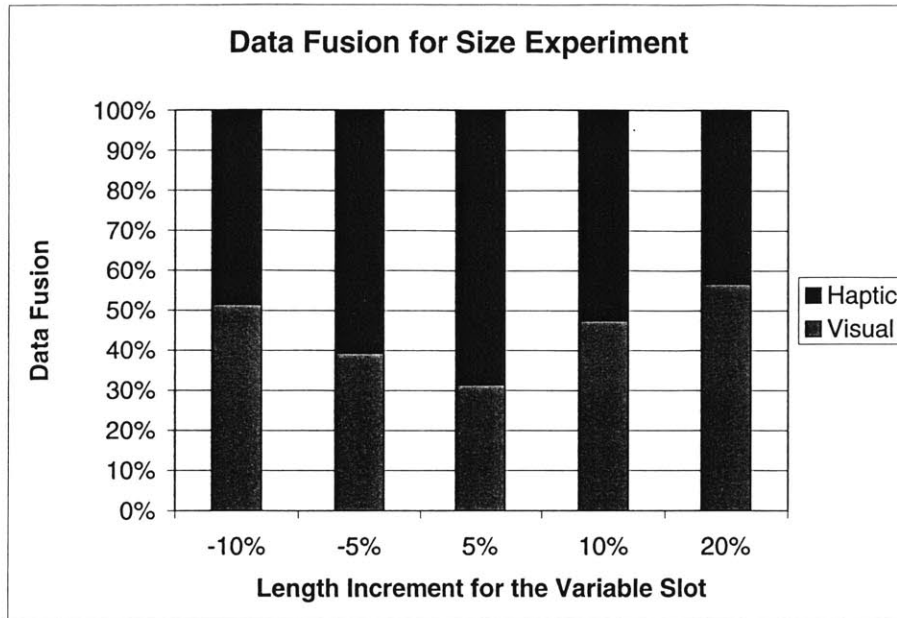

Figure 5-12: Fusion of sensory data in the size discrimination experiment.

result, we speculate that this perceptual illusion may be due to the human kinesthetic system. We observed that the subjects typically pressed each button one at a time and palpated it using vertical oscillatory up and down motion until they made a decision. During this process, only the wrist and elbow joints of the arm were active if the button was close to the subject. However, if the button was further away, the subjects extended their arm to reach the button and their elbow and shoulder joints were activated and thus contributed to the judgment of stiffness.

In these stiffness perception experiments, we did not observe any significant difference in the response of subjects for S-S and R-F configurations when visual and haptic cues were both provided to the subjects. We believe that there are two effects that contribute to the outcome. These effects cancel each other, leading to no observable difference between the curves: (1) Due to perspective effects, visually perceived deformation of a button that is farther from us is less than the closer one. Hence, the button that is farther from us is expected to be perceived as stiffer if only visual cues are available. (2) Due to the attributes of human kinesthetic system, we have also

seen that (see discussion above) the objects that are farther from us are perceived to be softer when there is no perspective cue in the visual scene. Hence, it seems that these two effects cancel each other and our sensory system successfully integrates the information coming from haptic and visual modalities, resulting in a practically unbiased perception.

# Chapter 6

## Future Work

### 6.1 Real Environment Experiments on Haptic Perspective

Many psychophysicists have been interested in human haptics research. The research work mentioned in Chapters 3 - 5 can also be done in the real environment with appropriate hardware setups. Then the results from experiments with real and virtual objects can be compared and both visual and/or haptic displays in VEs can be modified for more realistic interactions.

### 6.2 Improvement Work on the (Extended) Stylus

Inertia and/or friction need to be added to the (extended) stylus to make it approximate the real environment better. Human perceptual experiments in real and virtual environments can be conducted to improve the rendering quality in VEs.

## **6.3 Human Experiments on the Extension of Stylus**

Previously, some research has been done on the haptic perception by wielding a long rod or contacting objects using a rod (e.g. probing) (Carello et al. 1992; Chan, 1994). These experiments investigated the human capability to estimate distance and/or rod length. The results show that the inertia of the rod is an important factor. After adding inertia and other object properties to the stylus of a haptic interface through software, we can also conduct similar research on this topic in VEs. By comparing the results, we can modify the current VE displays to match the data obtained in real environments so as to have realistic VEs.

## **6.4 The Expansion of 5 DOF to 6 DOF**

In the ray-based rendering, with two PHANTOMs connected, the device can reflect appropriate 3D force and torque in two directions. But the feedback resulting from external torque in the axial direction cannot be applied with this setup. Dr. Iwata has suggested a method to overcome this limitation with a clever screw motion mechanism (Iwata, 1993). In addition, a corresponding rendering method needs to be developed to apply this technology.

## **6.5 Application of the Idea of Extending Stylus to Other Areas**

After the stylus is virtually extended with two haptic devices connected, the range of reach can be extended and VEs in which humans use long hand tools to touch farther objects can be constructed. The extension need not necessarily be linear, and other shapes such as a bent stick can be virtually created and appropriate forces can be applied using the two haptic devices. This enables many more possibilities concerning the shape of the tool, which will not be limited to a short stick. But using

shapes other than a straight stylus will result in torques in the axial direction and the technology mentioned in the section above needs to be developed first.



# Bibliography

- [1] C. Basdogan, C. Ho, and M. A. Srinivasan. A ray-based haptic rendering technique for displaying shape and texture of 3d objects in virtual environments. In *Proc. of ASME Winter Annual Meeting*, 1997.
- [2] G. L. Beauregard and M. A. Srinivasan. Sensorimotor interactions in the haptic perception of virtual objects. In *Touch Lab Report 5*. RLE Technical Report No. 607, 1997.
- [3] C. Carello, P. Fitzpatrick, and M. T. Turvey. Haptic probing: Perceiving the length of a probe and the distance of a surface probed, 1992.
- [4] T. Chan. Haptic perception of partial-rod lengths with the rod held stationary or wielded. In *Perception and Psychophysics*, number 55-5, pages 551-561, 1994.
- [5] S. Coren, L. M. Ward, and J. T. Enns. *Sensation and Perception*. Harcourt Brace, 1993.
- [6] J. D. Foley, A. van Dam, S. K. Feiner, and J. F. Hughes. *Computer Graphics: Principles and Practice*. Addison-Wesley, 1995.
- [7] Dennis Hancock. The sense of touch with a single phantom haptic device. In *Proc. of the 1st PHANToM User's Group Workshop*, 1996.
- [8] M. Heller and W. Schiff. *The Psychology of Touch*. Lawrence Erlbaum Associates, Publishers, 1991.

- [9] C. Ho, C. Basdogan, and M. A. Srinivasan. Haptic rendering: Point- and ray-based interactions. In *Proc. of the 2nd PHANTOM User's Group Workshop*, 1997.
- [10] A. I. Hou and M. A. Srinivasan. Multimodal virtual environments: Magic toolkit and visual-haptic interaction paradigms. In *Touch Lab Report 8*. RLE Technical Report No. 620, 1998.
- [11] H. Iwata. Pen-based haptic virtual environment. In *Proc. of IEEE Virtual Reality Annual International Symposium*, number 55-5, pages 287-292, 1993.
- [12] D. Kohn. Device brings new sense of purpose to tactile research. *The New York Times*, Dec 27, 1997.
- [13] T. H. Massie. Initial haptic explorations with the phantom: Virtual touch through point interaction. Master's thesis, MIT, 1996.
- [14] T. H. Massie and J. K. Salisbury. The phantom haptic interface: A device for probing virtual objects. In *Proc. of the ASME Dynamics Systems and Control Division*, number 55-1 in ASME, pages 295-301, 1994.
- [15] J. K. Salisbury, D. Brock, T. H. Massie, N. Swarup, and C. B. Zilles. Haptic rendering: Programming touch interaction with virtual objects. In *ACM Symposium on Interactive 3D Graphics*, 1995.
- [16] M. A. Srinivasan. Haptic interfaces. In N. I. Durlach and A. S. Mavor, editors, *Virtual Reality: Scientific and Technological Challenges*, chapter 4, pages 161-187. National Academic Press, 1994.
- [17] M. A. Srinivasan and C. Basdogan. Haptics in virtual environments: Taxonomy, research status, and challenges. *Computers and Graphics*, 21(4):393-404, 1997.
- [18] M. A. Srinivasan, G. L. Beauregard, and D. L. Brock. The impact of visual information on the haptic perception of stiffness in virtual environments. In *Proc.*

of the *ASME Dynamics Systems and Control Division*, number 58 in ASME, pages 555–559, 1996.

- [19] J. Wernecke. *The Inventor Mentor*. Addison-Wesley, 1994.
- [20] C. B. Zilles and J. K. Salisbury. A constraint-based god-object method for haptic display. In *IEEE International Conference on Intelligent Robots and System*, 1995.

5730-46