

Coordination and Sharing at the Interfaces

by

Vivian I-Wen Lin

A.B. Linguistics with Other Subjects (Folklore and Mythology)
Harvard University, 1994

M.A. Linguistics
School of Oriental and African Studies, University of London, 1995

Submitted to the Department of Linguistics and Philosophy
in Partial Fulfillment of the Requirements
for the Degree of

Doctor of Philosophy

at the

Massachusetts Institute of Technology
September 2002

© 2002 Massachusetts Institute of Technology
All rights reserved.

Signature of Author _____

Department of Linguistics and Philosophy
August 14, 2002

Certified by _____

David Pesetsky
Professor of Linguistics, Thesis Advisor

Accepted by _____

Alec Marantz
Professor of Linguistics
Head, Department of Linguistics and Philosophy

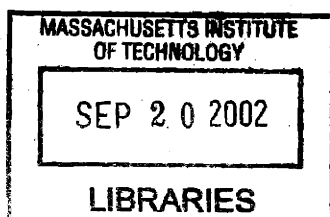

ARCHIVES]]

Coordination and Sharing at the Interfaces

by

Vivian I-Wen Lin

Submitted to the Department of Linguistics and Philosophy
on September 6, 2002 in Partial Fulfillment of the
Requirements for the Degree of Doctor of Philosophy
in Linguistics

ABSTRACT

This thesis examines properties of a type of coordinate structure that involves shared material (i.e., elements above the point coordination that c-command all of the conjuncts), what is referred to as a sharing structure. Following the work of Johnson 1996, sharing structures are argued to exist using scope and binding facts in Gapping contexts. The role that sharing structures play in a wide variety of syntactic phenomena is then investigated. A new theory of Gapping is proposed, in which sharing structures (or Small-Conjunct structures, as they are traditionally referred to within the context of Gapping) play a central role. It is claimed that Gapping is a deletion operation which must be triggered by a specific syntactic environment – namely, a sharing structure with particular morpho-syntactic features. Sharing structures are then used to investigate the relationship between the Coordinate Structure Constraint (CSC) and A-movement. Novel evidence is presented which reveal that A-movement exhibits CSC effects. It is shown that A-movement is similar to Quantifier Raising (QR) in the way that it obeys the CSC, and that both of these are unlike overt A'-movement. Finally, sharing structures are applied in the analysis of determiner sharing, a phenomenon first described by McCawley (1993), in which determiners on Noun Phrases (NPs) in initial conjuncts may be "shared" by corresponding, determinerless NPs in non-initial conjuncts, so long as a particular form of Gapping has taken place. Two previous analyses (Johnson 2000 and Lin 2000) are considered and revised, resulting in a new proposal regarding the syntax of Determiner Phrases (DPs), in which each determiner head (D) must be licensed by a functional head higher in the tree. It is argued that placing this new syntax of DPs in the context of sharing structures provides a simple account of the determiner sharing facts.

Thesis Supervisor: David Pesetsky

Title: Professor of Modern Languages and Linguistics

ACKNOWLEDGEMENTS

I feel extremely fortunate to have had the opportunity to exist, study, live, and breathe in the MIT Linguistics Department these past years. It is a remarkable place, and I've gained more than I can express from having spent time there. All of the following people (as well as many who I fear will not be listed – not because they are forgotten!) have made enormous contributions to my learning and my life at MIT:

First and foremost, I am indebted to the members of my thesis committee, Danny Fox, Kyle Johnson, Norvin Richards, and especially the chair of my committee, David Pesetsky. They have been great teachers. I thank Danny Fox for the power of his insight, and his unerring ability to see through to the core of any proposal. I thank Norvin Richards for his clarity and perception, and for always following through in pursuit of the predictions. When I began at MIT, Danny and Norvin were fellow students; they were as helpful and inspiring to me then as they are now. I thank Kyle Johnson for being willing to traverse the Mass Pike, and for being so generous with his time. His research has been a great source of inspiration to me, and I am grateful to have had the opportunity to work directly with him. I especially appreciate his always being so agreeable, even in disagreement. Finally, I thank David Pesetsky for the countless meetings, for his constant support, and for his lateral thinking. The seeds of this thesis were planted with his help years ago, and I would not be where I am today without him. To all of my thesis committee members, thank you for your patience and your encouragement.

This thesis has also benefited from my talks with other professors at MIT, as well as from the lessons I learned from them more generally. In particular, however, I would like to thank Alec Marantz for being willing to read and comment on earlier versions of this thesis. His insights always have an eye-opening effect on me, and I have learned much from him.

Because we are products of our experience, I would like to thank my first teachers in linguistics: Jill Carrier, Sam Epstein, Mark Hale, Susumo Kuno, Charles Reiss, and Höskuldur Thráinsson at Harvard University, and Wynn Chao, Monik Charette, Jonathan Kaye, Ruth Kempson, and Shalom Lappin at the School of Oriental and African Studies, University of London.

I would also like to express my thanks to Bert Vaux, who has taught me valuable lessons about teaching.

My time in the department has been greatly enriched by my fellow students. I would like to thank my classmates: Calixto Aguero-Bautista, Sveva Besana, Bridget Copley, Meltem Kelepir, Cornelia Krause, Jay Rifkin, and Sonny Vu. I look back on our first year together in Building 20 with much fondness. I would also like to thank certain students who helped make the department a real intellectual and social community for me: Allison Adler, Pranav Anand, Karlos Arregi, Teal Bissell, Marie-Claude Boivin, Benjamin Bruening, Marie-Hélène Côté, Justin Fitzpatrick, Elissa Flagg, Elena Guerzoni, Martin Hackl, Valentine Hacquard, Franny Hsiao, Michela Ippolito, Yoonjung Kang, Idan Landau, Ora Matushansky, Martha McGinnis, Jon Nissenbaum, Becki Norris, Isabel Oltra-Massuet, Orin Percus, Liina Pylkkänen, Andrea

Rackowski, Joey Sabbagh, Uli Sauerland, Philippe Schlenker, Hooi Ling Soh, Luciana Storto, Shoichi Takahashi, Michael Wagner, Maryann Walter, and Susi Wurmbrand.

One of the many advantages to being at MIT is the number of visitors we have in the department each year. I would like to thank the following people, who helped contribute to my education, and who have helped make the general linguistics community a more welcoming place for me: Artemis Alexiadou, Elena Anagnostopoulou, Maya Arad, Marlyse Baptista, Molly Diesing, Caterina Donati, Olga Fernandez, Utpal Lahiri, Alan Munn, Francesca Panzeri, Josep Quer, Anna Roussou, Shigeko Shinohara, and Kie Zuraw. Special thanks go to Rajesh Bhatt, Lisa Matthewson, and Roumi Pancheva.

Jen Purdy and Mary Grenham in Departmental Headquarters deserve thanks for helping to make my time at MIT go so smoothly.

I would also like to thank Benjamin Bruening, Ikuska Ansola-Badiola, Wayne O'Neil, Maya Honda, and Ken Hale (who is sorely missed), for adding so significantly to my experience of community at MIT.

My time at MIT was greatly enriched by certain non-linguistic pursuits that played a central role in keeping me balanced and sane. For this, my thanks go out to: the members of bowl-ling; the Frigid Designators and the captains of the team, Olafur Jonsson, Josh Flaherty, and Clare Batty; the MIT Women's Ice Hockey Club and my coaches, Tony, Reggie, and Lukas; chamber music impresario Jaemin Rhee; and my bands, Cahies, The Billy Club, and The Screen (a.k.a. Lo Lux).

Finally, a big thank you to those who helped make the finishing of this thesis possible: my fellow dissertators, whose camaraderie made the experience less lonely, and in particular, Elissa Flagg, my fellow night-shifter, without whom the very late nights in the department would have proven much less productive. I thank her for her support and the shared experience. Thanks also go to Joanne Lin, Jill Nebeker, and Ana Yook, for their enormous help in the non-linguistic parts of my life which couldn't be ignored while I was in the finishing stages. I am very lucky to have such caring and supportive people in my life, and I greatly appreciate the time and energy that they so generously gave to me.

This thesis is dedicated to my family: Mary and Bob, and Joanne and Jessica and Jeremy.

TABLE OF CONTENTS

<i>ABSTRACT</i>	2
<i>ACKNOWLEDGEMENTS</i>	3
<i>TABLE OF CONTENTS</i>	5
1. Introduction: Overview of the Thesis	7
2. Gapping: The Large versus the Small	9
2.1 The Large-Conjunct Approach	12
2.1.1 Problems for the Large-Conjunct Approach	12
2.1.1.1 Wide-scope Modal Sentences	13
2.1.1.2 Wide-Scope Negation Sentences	15
2.1.1.3 Cross-Conjunct Binding Sentences	16
2.1.2 Interim Summary: The Large-Conjunct Approach	17
2.2 The Small-Conjunct Approach	18
2.2.1 Evidence in Favor of the Small-Conjunct Approach	19
2.2.2 Potential Problems for the Small-Conjunct Approach	22
2.3 Summary: Sometimes Its Necessary to be Small	27
3. The Interpretation of Shared Structures at PF: Sharing and Gapping	28
3.1 Starting Point: The Siegel Puzzle	31
3.2 Gapping Generalizations	32
3.3 Dealing with Deletion	35
3.3.1 The Highest Head Generalization	37
3.3.2 The Chain of Deletion Generalization	40
3.3.3 XP-Deletion versus X-Deletion: An Alternative Approach	43
3.4 Triggers for Deletion	46
3.4.1 Deletion That May Be Triggered: Lasnik's Salvation By Deletion	46
3.4.2 Deletion That Must Be Triggered: Gapping in Shared Structures	50
3.5 The Siegel Puzzle: Recap and Resolution	55
3.6 Conclusion and Caveat	57
4. The Interpretation of Shared Structures at LF: A-movement and the CSC	59
4.1 A-movement and the Coordinate Structure Constraint	63
4.2 The CSC as a Constraint on Representations	64
4.3 CSC effects and A-movement	69
4.3.1 What the CSC Predicts	70
4.3.2 Evidence of Reconstruction: A Missing Reading	72

4.3.3 An Exception to the CSC Effect on A-movement	73
4.3.4 Johnsons's (1996) Puzzles.....	75
4.4 The CSC Effect and Other Constraints on Interpretation.....	78
4.4.1 The CSC Effect versus a Ban on Reconstruction	78
4.4.2 The CSC Effect versus Cross-Conjunct Binding: The Case of <i>a single NP</i>	80
4.4.3 The CSC Effect and the Epistemic Containment Principle	82
4.5 Conclusion	84
5. More Sharing and Gapping: Determiner Sharing	85
5.1 Determiner Sharing and Necessary T-sharing	87
5.2. Previous Small-Conjunct Approaches to Determiner Sharing	91
5.2.1 Johnson's (2000) Analysis of Determiner Sharing	91
5.2.2 Lin's (2000) Analysis of Determiner Sharing	97
5.2.3 Some Drawbacks of Johnson 2000 and Lin 2000.....	102
5.3 A New Determiner-Sharing Analysis: Extending Johnson 2000.....	103
5.4 Determiner Sharing Across Possessive Relative Clauses	106
5.5 Conclusion and Further Issues	109
6. Conclusion	111
BIBLIOGRAPHY	112

1. Introduction: Overview of the Thesis

This is a thesis about sharing. Specifically, it examines various properties of coordinate structures which involve *shared material*. The notion of sharing which will be relevant in the chapters that follow may be defined structurally:

(1) Sharing in Coordinate Structures

a. α_1 and α_2 share β if β c-commands both α_1 and α_2 .

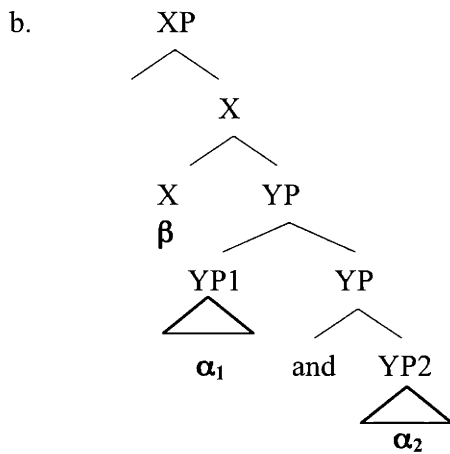

In this thesis, we will see that this seemingly modest structure provides a window into quite an array of syntactic issues. It will tell us something about how Gapping and ellipsis work. In particular, it will play a central role in a proposed theory of Gapping which treats Gapping as the result of a deletion operation that is triggered in a sharing structure. The structure in (1b) will also tell us something about movement (and A-movement, in particular). It will provide us with a tool for examining conditions on movement and on the interpretation of the results of movement. Finally, the structure in (1b) will also reveal to us something about the syntax of DPs. These seemingly disparate issues are all addressed in the following chapters, and are held together by a common thread, namely, the sharing structure in (1).

Throughout the chapters that follow, many of the effects that we will attribute to the sharing structure are effects which arise at the PF or LF interface; that is, we will be looking at the effects of how sharing structures are interpreted at PF and LF. We will begin in Chapter 2

with an examination of a construction which is traditionally referred to as Gapping, illustrated in (2). It is in the context of Gapping, and a debate in the literature regarding the size of Gapped conjuncts, that I present arguments in favor of the existence of the sharing structure schematized in (1b), following the work of Johnson 1996.

(2) Jessica ate an apple and Joanne, an orange.

In Chapter 3, I propose the start of a theory of Gapping, one which makes the sharing structure a crucial trigger for the operation which produces Gapping. It will be emphasized that, while Gapping relies on sharing structures, sharing structures do not necessarily entail that Gapping will take place. In Chapter 4, I turn to an issue raised by the sharing structure in (1) for the Coordinate Structure Constraint (Ross 1967), a constraint on movement out of coordinate structures. An examination of how certain sharing structures are interpreted after movement has taken place will lead us to a deeper understanding of how the Coordinate Structure Constraint affects interpretation. In Chapter 5, I examine a peculiar type of Gapping phenomenon known as *determiner sharing* (where "sharing" is being used in a descriptive way as part of the name of the phenomenon). Again, the sharing structure will play a central role in our analysis, which will provide us with a tool for studying the syntax of DPs, and the organization of clausal architecture, more generally.

I will discuss assumptions required by my proposals as the need arises in the chapters that follow.

2. Gapping: The Large versus the Small

As it was first described by Ross, "Gapping" is a rule which "operates to delete indefinitely many occurrences of a repeated main verb in a conjoined structure" (Ross 1967: 250). The Gapping rule was hypothesized to derive sentences like (1b) from (1a):

- (1) a. Jessica ate an apple and Joanne ate an orange.
b. Jessica ate an apple and Joanne, an orange.

Any syntactic analysis of structures such as (1b) will necessarily include hypotheses regarding two central features: (1) the size of the conjunct containing the gap (henceforth *gapped conjunct*), and (2) the mechanism responsible for producing the gap. In the discussion that follows, I adopt a practice common in the literature and classify approaches to Gapping according to the size property, dividing them into two groups: one which hypothesizes that gapped conjuncts are actually much larger than they appear on the surface (in fact equal in size to their ungapped counterparts – the *Large-Conjunct Approach*); and one which hypothesizes that gapped conjuncts are smaller than their ungapped counterparts (the *Small-Conjunct Approach*). (For further discussion along these lines of previous analyses of Gapping, see Wilder 1987, Hartmann 2000.) Various proposals regarding the mechanism which produces the gap – including PF deletion/ellipsis, base generation of a null element, and overt ATB movement – will be discussed in the context of the Large-Conjunct versus Small-Conjunct Approaches.

Proponents of the Large-Conjunct Approach to Gapping commonly argue that large-conjuncts alone are needed for the analysis of Gapping (see, in particular, the discussions in Wilder 1987: 62–68 and Hartmann 2000: 32–51 and subsequent chapters); that is, they deny the possibility of a Small-Conjunct Approach to Gapping.¹ The aim of this chapter is to argue against this view by showing that the Small-Conjunct Approach provides the correct analysis for a subset of Gapping constructions.

¹ Proponents of the Large-Conjunct Approach to Gapping do not necessarily deny the existence of small-conjunct structures. For example, Hartmann (2000: 34–37) argues that small-conjunct structures may be needed for certain

In the following sections, I use standard terminology to refer to different parts of the Gapping construction: *gap* refers to any missing material in a conjunct; *remnant* refers to any element which remains in a gapped conjunct; and *correspondent* refers to elements in non-gapped conjuncts which correspond (syntactically/semantically) to remnants in gapped conjuncts.

- (2) { Jessica } ate { an apple } and { Joanne } { — } { an orange }
 { CORRESPONDENT1 } { CORRESPONDENT2 } { REMNANT1 } { GAP } { REMNANT2 }

According to Ross's original description of the Gapping rule, Gapping produces sentences that are missing finite verbs. In this chapter, I make a slight departure from this characterization and include sentences that are missing finite auxiliaries or modals (but which still retain their verbs) in the discussion of Gapping:²

- (3) a. **Canonical Instance of Gapping**
 Jill watched the hockey game and Jori ~~watched~~ the luge race.
- b. **Further Instance of Gapping: Missing Tense**
 Jill will referee the hockey game and Jori ~~will~~ time the luge race.

Thus, for the purposes of this chapter, "Gapping" will be used as a descriptive term for the types of sentences illustrated in (3a) and (3b). As we will see in the discussion that follows, the Large-Conjunct and the Small-Conjunct Approaches actually categorize the data in (3) differently. In particular, the Large-Conjunct Approach treats both (3a) and (3b) as the results of Gapping.³ Since our aim is to argue for the existence of small-conjunct structures, we proceed by showing

cases of DP-level coordination. However, Hartmann maintains that Gapping is restricted to large-conjunct structures.

² Strike-through indicates elements which are not pronounced. Use of this typographic convention is not meant to imply a particular analysis, e.g., that gaps contain underlyingly present lexical material which is then subjected to a deletion process; rather, it is used as a way to unambiguously indicate the gap's lexical content. I alternate freely between using strike-through and dashes, and sometimes use nothing at all to indicate gaps.

³ Note that Hartmann (2000), who argues for a Large-Conjunct Approach to Gapping, suggests an even further expansion of the range of Gapping data: because she proposes that Gapping is a rule which specifically targets a particular feature hosted by C° (at least in German), she views sentences with only C missing in non-initial conjuncts as possible Gapping constructions.

that the Large-Conjunct Approach is wrong to extend the treatment of sentences like (3a) to sentences like (3b).⁴

Before beginning the discussion of the structure of Gapping, a few disclaimers are in order. First, as has been well documented throughout the literature, a number of pragmatic, semantic, and phonological factors interact to constrain Gapping (e.g. Bolinger 1958, Hankamer 1973, Kuno 1976, Sag 1976, Sag et al. 1985). I will assume that such constraints are capable of being satisfied in the examples being discussed. For notational convenience, I will also assume that coordination is asymmetric, not flat.⁵ In particular, I adopt a structure which has been argued for by Munn (1987), among others, where coordination is represented as a head, and conjuncts are either complements of the coordinate head, or adjuncts (4). (On the structure of coordination, see Progovac (1998a, b) and references cited therein.)

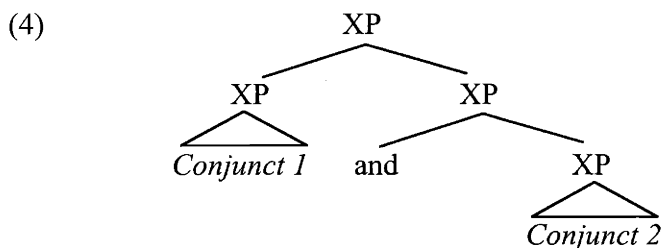

The discussion is organized as follows. In Section 2.1, we will consider the Large-Conjunct Approach to Gapping. In Section 2.1.1, we will see three different types of data that are problematic for the Large-Conjunct Approach. The problem faced by the Large-Conjunct Approach is summarized in Section 2.1.2. In Section 2.2, we will see how the data which are problematic for the Large-Conjunct Approach may be accounted for using a Small-Conjunct Approach (Section 2.2.1), though the Small-Conjunct Approach is not without its own potential problems (Section 2.2.2). We conclude with a summary in Section 2.3.

⁴ In Chapter 3, we will adopt a stricter use of the term "Gapping," using it to refer only to those constructions in which elements are missing because they have undergone some kind of deletion process. At this point in the discussion, however, this level of detail is premature.

⁵ This assumption is not crucial for any of the discussion that follows, though it does provide a natural account for binding possibilities between different conjuncts (see Chapter 4, FN 16). This is not to say that the particular structure of coordination does not matter; whatever structure is adopted may play a role in the analysis of one of the features we will examine more closely in Chapter 4 (namely, asymmetric A-movement). The ramifications and consequences of this particular assumption will not be pursued here, however.

2.1 The Large-Conjunct Approach

Large-Conjunct Approaches to Gapping suggest that gapped conjuncts match in size with their ungapped counterparts. Thus, material to the left of the coordination is hypothesized to sit in one conjunct, and material to the right of the coordination is hypothesized to sit in an equally large and separate conjunct of its own. Some kind of ellipsis mechanism (e.g. failure to Spell-Out, Wilder 1997; base generation of a null element, Williams 1997; prosodic reduction at PF, Hartmann 2000) then applies to prevent some of the material in the right-hand conjunct from being pronounced.

- (5) **Large-Conjunct Approach** (e.g. Neijt 1979, van Oirsouw 1987, Wilder 1997, Hartmann 2000)

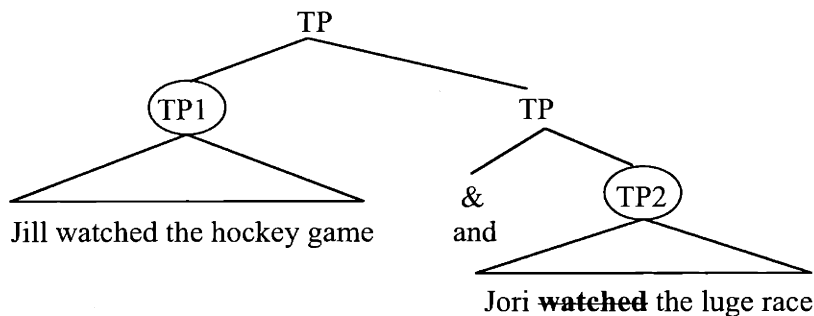

2.1.1 Problems for the Large-Conjunct Approach

The main obstacles facing a Large-Conjunct analysis of Gapping come from binding and scope facts. In the structure posited under a Large-Conjunct Approach (5), no element sitting to the left of the coordination (i.e., in the first TP conjunct) c-commands any element sitting to the right of the coordination (i.e., in the second TP conjunct). The Large-Conjunct Approach therefore predicts that an element in the first TP conjunct will not be able to bind an element in the second TP conjunct; similarly, an element in the first TP conjunct will not be able to take

scope over an element in the second TP conjunct.⁶ These predictions are challenged by examples which have been observed and discussed by a variety of researchers (e.g. Siegel 1984, 1987, Oehrle 1987, McCawley 1993; see also the discussion in Johnson 1996, 2000 and Lin 2000):

(6) **Problematic Data for the Large-Conjunct Approach**

- a. **Wide-Scope Modal** (Siegel 1987: ex. 7a)
Ward can't eat caviar and Mary eat beans.
- b. **Wide-Scope Negation** (based on Oehrle 1987)
Mrs. J can't live in Boston, or Mr. J anywhere near LA.
- c. **Cross-Conjunct Binding** (McCawley 1993: ex. 15a)
No one;'s duck was moist enough, or his; mussels tender enough.

I discuss each of these data points in turn.

2.1.1.1 Wide-scope Modal Sentences

In a wide-scope modal sentence, a modal element is interpreted as having wide scope over two (or more) conjuncts. The wide-scope modal sentence (6a), repeated below, has only a wide-scope modal reading in which the negated modal, *can't*, takes scope over both conjuncts, as paraphrased in (7b):

(7) **Wide-Scope Modal**

- a. Ward can't eat caviar and Mary eat beans.
- b. It can't be the case that Ward eats caviar while Mary eats beans.⁷ ¬CAN(A&B)

⁶ These predictions rest on the assumption that QR of an element out of one of the TP conjuncts is blocked. (If this were not the case, than an element could be raised via QR out of a single TP conjunct to a position high enough to c-command elements in the other conjunct(s).) Although it may be tempting to attribute this blocking effect to Ross's Coordinate Structure Constraint, which states, "In a coordinate structure, no conjunct may be moved, nor may any element contained in a conjunct be moved out of that conjunct" (Ross 1967: 89, ex. 84), we will see in Section 2.2 that the CSC does not block movement out of a single VP conjunct (discussed in greater detail in Chapter 4). This suggests that the CSC cannot provide the account for the blocking of QR out of a single TP conjunct. Whatever the source of the blocking effect may be, it will not affect the argument being presented in this chapter, which rests on the fact that TP-level coordination exhibits different properties from VP-level coordination.

⁷ I have paraphrased (7) using *while*, which implies a simultaneity of events. Although I believe that this "simultaneity" reading does exist (and is perhaps the most salient one available), temporal simultaneity of events is

The wide-scope reading of (7a) contrasts with the *distributed modal reading*, the only reading possible when the modal is pronounced in each conjunct:

(8) **Distributed Modal**

a. Ward can't eat caviar and Mary can't eat beans.

b.

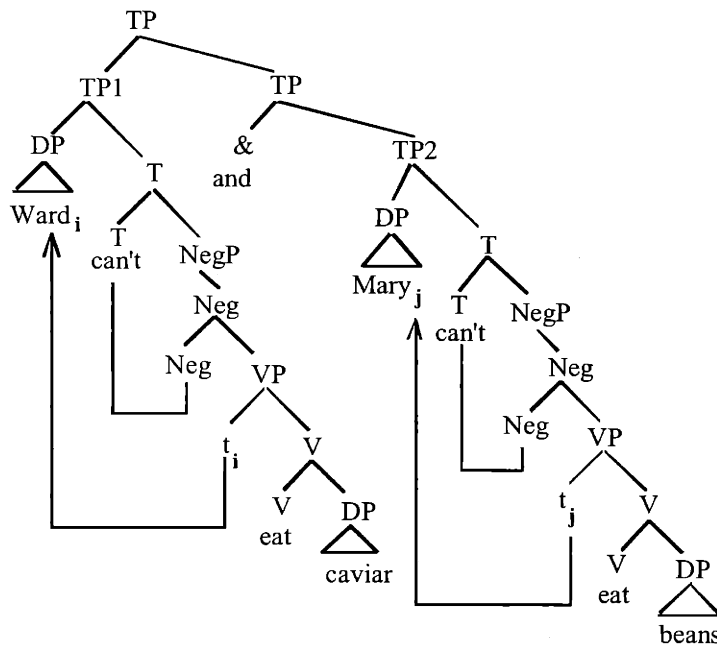

Under a Large-Conjunct approach, (7a) would be analyzed as conjoined TPs (or possibly CPs) – in other words, as being derived from (8). But (7a) and (8a) do not mean the same thing.

Proponents of the Large-Conjunct approach must therefore explain why the second instance of *can't* hypothesized to be present in the second conjunct of (7a) cannot be interpreted as if it were present.

not required. E.g., it is possible to say the following, even though the two event being talked about could not take place at the exact same time: *Your ancestors from a century ago can't have won the lottery, and your descendants expect to claim it (along with the interest) a century later.* (I thank David Pesetsky for bringing this scenario to my attention.)

2.1.1.2 Wide-Scope Negation Sentences

According to DeMorgan's Law, when disjunction appears under the scope of certain operators, including negation, the resulting construction has identical truth conditions to one which can be represented with conjunction: $\neg(A \vee B) = \neg A \ \& \ \neg B$ (see Vainikka 1987, Higginbotham 1991, among others, for discussion). The crucial property to pay attention to is the scope of the operator – negation, in the cases we will discuss – relative to the disjunction. Negation must take scope over the entire disjunction in order for the equivalence to hold. I will refer to sentences having this structure as *wide-scope negation* sentences, and I will refer to their interpretation as *neg-over-or* interpretations. *Neg-over-or* interpretations contrast with the interpretation of structures in which disjunction takes higher (or highest) scope – *wide-scope or* sentences. The *neg-over-or* and the *wide-scope or* interpretations can be distinguished using an entailment diagnostic discussed in Vainikka 1987: a *wide-scope or* sentence (10) may entail only one or the other of its disjuncts (either (9a) or (9b)), while a *wide-scope negation* sentence (11) entails both/all of its disjuncts ((9a) and (9b)).

(9) **Disjuncts**

- a. Sarah didn't skate on Saturday.
- b. Samantha didn't skate on Sunday.

(10) **Wide-Scope *or***

Sarah didn't skate on Saturday, or Samantha didn't skate on Sunday. $\neg A \vee \neg B$
 \neq Sarah didn't skate on Saturday AND Samantha didn't skate on Sunday.

(11) **Wide-Scope Negation**

Sarah didn't skate on Saturday, or Samantha skate on Sunday. $\neg A \ \& \ \neg B$
 $=$ Sarah didn't skate on Saturday AND Samantha didn't skate on Sunday.

The *wide-scope or* sentence must consist of TP- (or CP-) sized conjuncts. Each clause has its own instance of tense and negation, and since neither negation takes scope over (i.e., c-commands) *or*, the *neg-over-or* reading is not available.

(12)

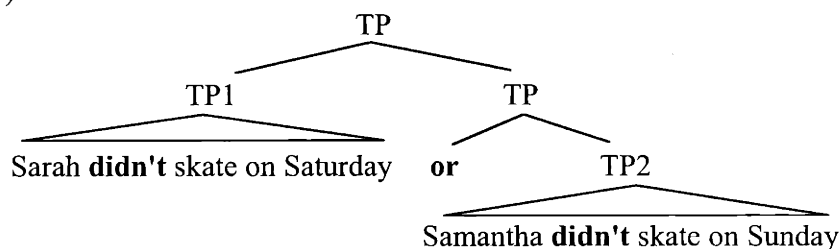

In order for the neg-over-or reading to be possible in (11), *or* must be under the scope of negation. However, under a Large-Conjunct approach, (10) would be treated as the underlying source of (11). Given the apparent inability of negation to take scope over the disjunction in (12), the Large-Conjunct approach is left with the problem of explaining how negation is able to take scope over the disjunction in (11).

2.1.1.3 Cross-Conjunct Binding Sentences

In a cross-conjunct binding sentence, a quantifier in the first conjunct is able to bind a variable in the second subject.

- (13) a. No player_i's jersey was big enough, or her_i socks, long enough.
b. Not every student_i bought a hat, and her_i brother a sweatshirt.
(based on examples in McCawley 1993, Johnson 1996)

Given standard assumptions about binding, the first subject *not every student* in (13b) must c-command the second subject *her mother* in order for binding of *her* to take place. The ungrammaticality of (14) shows us that when TPs are coordinated, a quantifier in the first conjunct is unable to raise to position high enough to bind into the second conjunct (illustrated in (15)).

- (14) a. * No player_i's jersey was big enough, or her_i socks were long enough.
b. * Not every student_i bought a hat, and her_i brother bought a sweatshirt.

(15)

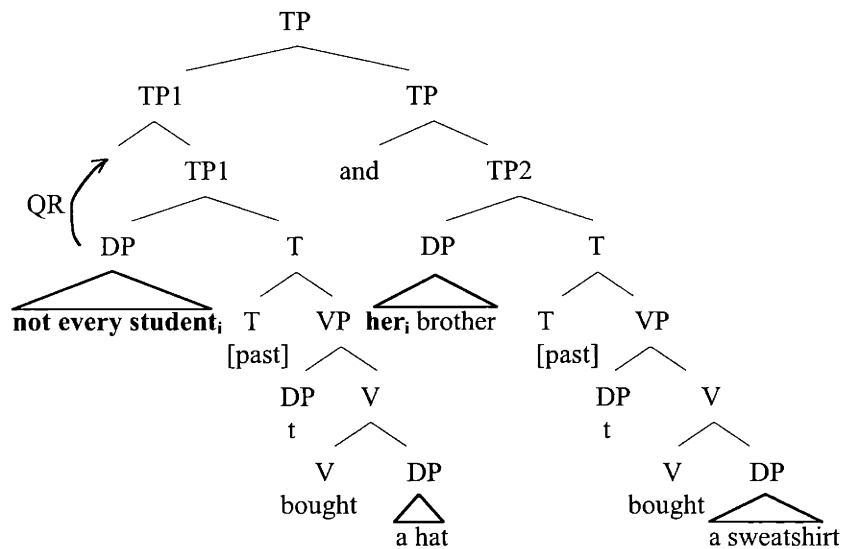

Under a Large-Conjunct Approach, the sentences in (13) would be analyzed as conjoined TPs, leading to the wrong prediction that they should be ungrammatical, just as their ungapped counterparts (i.e., their hypothesized underlying sources) are ungrammatical.

2.1.2 Interim Summary: The Large-Conjunct Approach

We have seen that a particular approach to Gapping, the Large-Conjunct approach, suffers from a major shortcoming: without additional stipulations or special machinery, the Large-Conjunct approach predicts that Gapped structures will, with respect to scope and binding, behave exactly like their ungapped counterparts. But we have seen evidence that Gapped structures may exhibit different behavior, in the context of wide-scope modal sentences, wide-scope negation sentences, and cross-conjunct binding facts. It is precisely this difference between Gapped versus ungapped sentences which has led some researchers to argue for a small-conjunct approach to Gapping.

2.2 The Small-Conjunct Approach

In a small-conjunct structure, some of the material in the initial part of the sentence sits outside (i.e., above) the conjoined material. Thus, for example, in the Small-Conjunct Approach to Gapping advocated by Johnson (1996), sentences with simple verb gaps are analyzed as consisting of a single, shared T node which sits above coordinated VPs.^{8,9} According to Johnson (1996), who assumes that verbs move overtly to T in English, Gapped verbs are the product of overt across-the-board (ATB) movement of the verbs to the single T node. Since Johnson also assumes the VP-internal Subject Hypothesis (e.g., Koopman and Sportiche 1985, 1991; Kitagawa 1986; Fukui and Speas 1986; Kuroda 1988), each coordinated VP may host its own overt subject. Johnson therefore needs to provide an account for the surface positions of subjects in Gapped sentences (i.e., the fact that the first subject appears to the left of elements in T, while the second subject remains to the right of T). He suggests that the first subject undergoes A-movement to Spec-T in order to satisfy the EPP requirement of the single T node (Johnson's (1996) "independent A-movement," which I refer to as *asymmetric A-movement*); meanwhile, the second subject is proposed to remain in situ.¹⁰

⁸ In this paper, I generally ignore the distinction between "big V" (V) versus "little v" (v) heads, utilizing them both only when necessary within a single tree. Assuming that v is responsible for licensing external arguments (see, e.g., Chomsky 1995, Kratzer 1996, Collins 1997, Marantz 1997), the structures being discussed would be more accurately described as vP-level coordinate structures.

⁹ Johnson (1996) does not discuss details of the structure of coordination, since they are not crucial to his analysis. For expository purposes, he presents coordination as a flat structure. When discussing his proposals, I translate his flat coordinate structures into binary branching structures, in keeping with the assumptions I have made regarding the structure of coordination. Nothing in the text hinges on this difference, however.

¹⁰ See Siegel 1987 for a different instantiation of the Small-Conjunct Approach to Gapping. Adopting (with minor adaptation) the Generalized Categorical Grammar framework of Bach 1983, Siegel analyzes Gapped sentences – more specifically, wide-scope modal sentences – as the product of VP-level coordination with the tensed auxiliary or modal being added outside the conjuncts, similar to the structure proposed in Johnson 1996. In contrast to Johnson 1996, however, Siegel invokes Bach's (1984) Right-Wrap Rule (essentially a linear re-ordering rule which places the tensed auxiliary or modal to the immediate right of the first subject) in order to account for the surface word order. Asymmetric A-movement thus constitutes one of the truly novel aspects of Johnson's (1996) Gapping proposal.

(16) a. Lynne scored one goal, and Nicole, two goals.

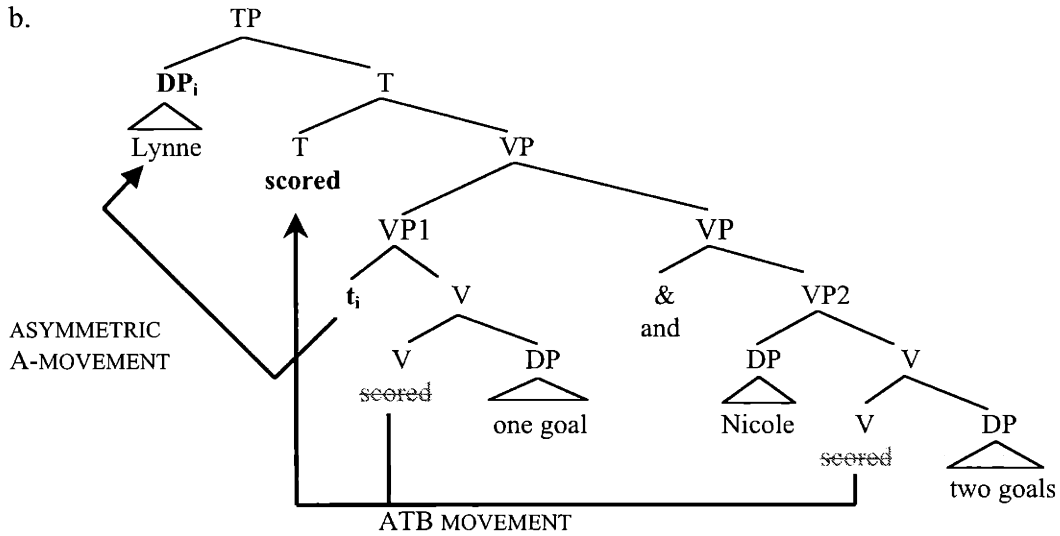

Johnson (1996, 2000; see also Lin 2000) uses the counterexamples to the Large-Conjunct Approach discussed in Section 2.1.1 as arguments in favor of small-conjunct structures. In contrast to the Large-Conjunct Approach, the Small-Conjunct Approach makes the correct predictions regarding scope and binding in Gapped structures.

2.2.1 Evidence in Favor of the Small-Conjunct Approach

Consider first the case of wide-scope modals. Recall that the Large-Conjunct Approach runs into difficulty because it posits ellipsis as the only source of difference between (17a) and (17b), raising the question of why (17a) and (17b) do not mean the same thing:

- (17) a. Alicia can't drop-pass on the right and Wendy can't shoot from the left.
 b. Alicia can't drop-pass on the right and Wendy ~~can't~~ shoot from the left.

A small-conjunct structure provides a simple solution to the conundrum. (17b) is analyzed as VP-level coordination under a shared T. Assuming that negation and the modal are generated

above both conjuncts, the wide-scope reading follows naturally.¹¹ In contrast, (17a) must consist of (at least) TP-level coordination, in order for each conjunct to be large enough to accommodate each instance of *can't*. The difference in underlying structures (correlating with the presence of one versus two modals-plus-negation) explains the difference in interpretations.

(18) Small-Conjunct Structure of (17b): Wide-Scope Modal

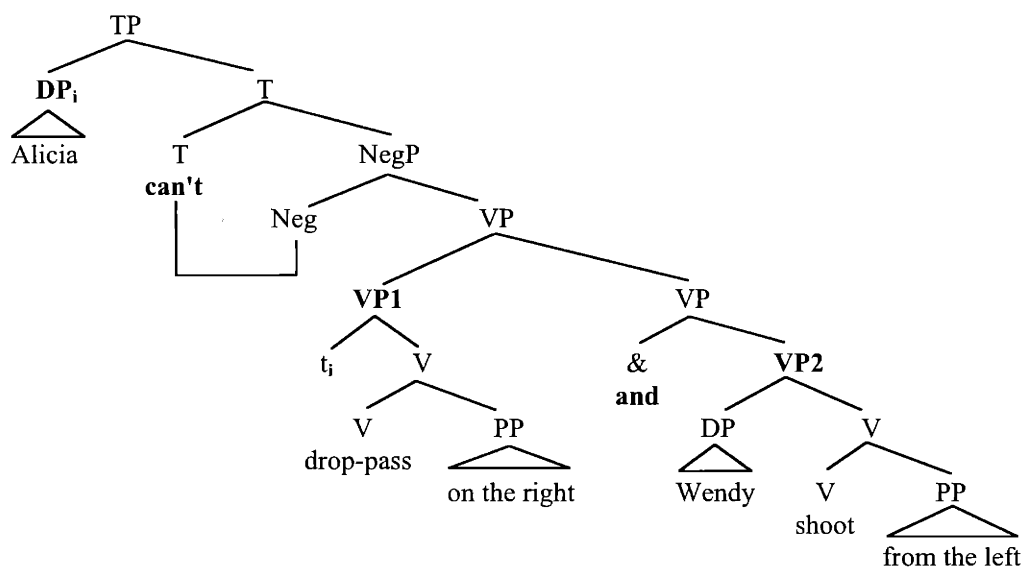

Similarly, a small-conjunct structure provides a natural account for the availability of the neg-over-*or* interpretation in Gapping. Since negation is base-generated in a position above the disjunction, negation is able to take scope over *or*.

(19) a. Sarah can't skate on Saturday, or Samantha skate on Sunday.

¹¹ I assume that auxiliaries and modals are base-generated (or eventually end up) in T.

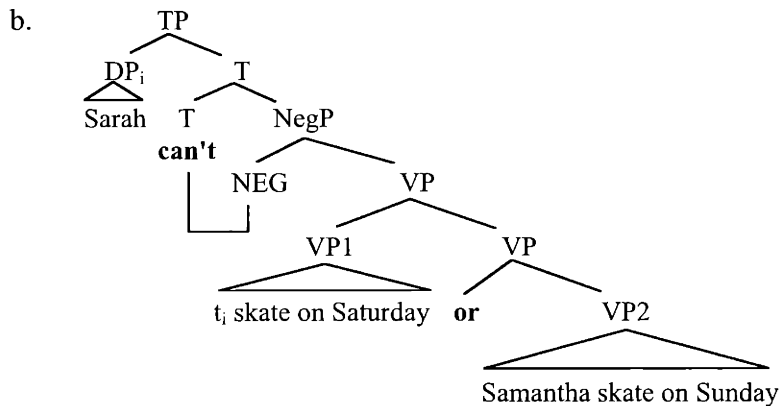

Cross-conjunct binding sentences provide more evidence in favor of the small-conjunct structure; additionally, they provide evidence for a crucial component of Johnson's small-conjunct analysis: asymmetric A-movement of the first subject out of the first VP-conjunct. The asymmetric A-movement neatly explains the possible binding relation between the first subject and the second subject in Gapping sentences. It is precisely this movement to a position above the coordination which allows the first subject to take scope over the second subject – something which is not available in a large-conjunct (e.g., TP-level) coordinate structure. (We will return to the nature of asymmetric A-movement, and in particular, the questions it raises regarding the CSC, in Chapter 4.)

(20) a. Not every girl_i bought a hat and her_i brother a sweatshirt.

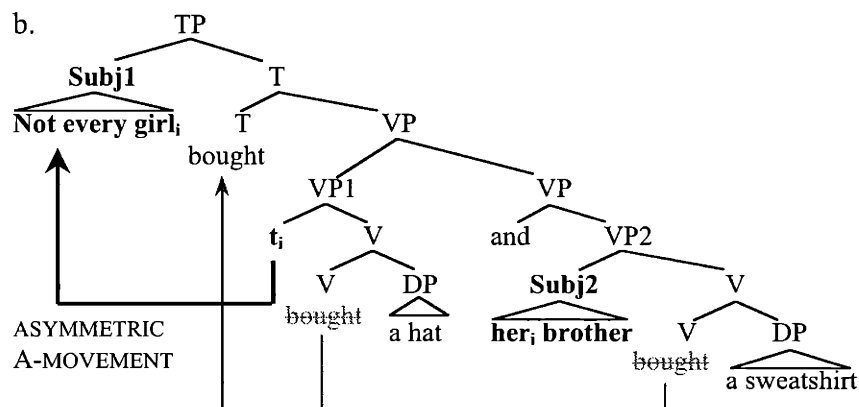

We have seen that the Small-Conjunct Approach fares better than the Large-Conjunct Approach with respect to wide-scope modals, wide-scope negation, and cross-conjunct binding in Gapping contexts. In each of these cases, scope and binding facts fall out straightforwardly as a result of the hypothesized small-conjunct structures. A number of the more unusual aspects of Johnson's small-conjunct analysis have not gone unchallenged in the literature, however. In the next section, I review some of the more common arguments which have been raised against this type of Small-Conjunct Approach.

2.2.2 Potential Problems for the Small-Conjunct Approach

Two key elements of Johnson's (1996) Gapping proposal are: 1) asymmetric A-movement of the first subject to Spec-T, and 2) overt ATB-movement of Gapped elements (either heads or phrases). The first element pivots around the issue of conjunct size, and in particular, the consequences of coordinating below T. The single T node has an EPP feature (e.g. Chomsky 1995: 232) that needs to be satisfied, and asymmetric A-movement of the first subject out of the first conjunct into Spec-T is the proposed solution to this need. As Johnson himself notes, the acceptability of asymmetric A-movement appears to violate the Coordinate Structure Constraint.¹² In order to reconcile the apparent existence of asymmetric A-movement with the CSC, which predicts that asymmetric A-movement should result in ungrammaticality, Johnson suggests that A-movement (of the first subject) is, for an as-yet ill-understood reason, simply not subject to the CSC.

Johnson's evidence relies on an analysis of ECM constructions which involves A-movement of embedded subjects to a higher position in the tree (for case-marking purposes). In particular, two types of ECM constructions are claimed to reveal this A-movement overtly: constructions involving particle verbs such as *made out* (21a) and constructions involving root-level adverbs such as *for some time* (21b). The reasoning proceeds as follows: if an embedded subject appears to the left of a verb particle or root-level adverb on the surface, then it must have

¹² There also exists an interesting set of exceptions to the CSC involving asymmetric A'-extractions, e.g., *What kind of music can you listen to and still get your work done?* (Goldsmith 1985: 136, ex. 6e). Because asymmetric A'-movement is only licensed when specific semantic conditions are met (for discussion, see Goldsmith 1985, Lakoff 1986, Culicover and Jackendoff 1997, Postal 1998, among others), I assume it is a phenomenon distinct from asymmetric A-movement.

undergone overt A-movement into the matrix clause. Johnson uses the grammaticality of the sentences in (22) as support for his claim that the CSC does not apply to A-movement out of the first conjunct of coordinate structures.

- (21) a. Mary made him_i **out** [t_i to be intelligent].
 b. Rocky has believed him_i **for some time** [t_i to be patient].
- (22) a. Mary made Reggie_i **out** [XP [XP t_i to be intelligent] and [XP Lukas to be kind]].
 b. Rocky has believed Reggie_i **for some time** [XP [XP t_i to be patient] and [XP Lukas to be encouraging]].
 (based on Johnson 1996: ex. 70)

Unfortunately, Johnson's effort to resolve the conflict between asymmetric A-movement, on the one hand, and the CSC, on the other, is not entirely persuasive. First, as Bernhard Schwarz has pointed out to me (p.c.), Johnson's interpretation of the ECM data is not unequivocal. In order for the ECM sentences to show what Johnson hopes for them to show, we must assume that the XPs in (22) are "small" – as small as they appear to be on the surface.¹³ However, there is nothing which forces this particular structural analysis. A large-conjunct analysis of the ECM sentences in (22), along with Gapping (and/or ellipsis, more generally), easily produces the same results:

- (23) a. [TP Mary made Reggie_i **out** [t_i to be intelligent]] and [TP ~~Mary made~~ Lukas_j **out** [t_j to be kind]].
 b. [TP Rocky has believed Reggie_i **for some time** [t_i to be patient]] and [TP ~~Rocky has believed~~ Lukas_j ~~for some time~~ [XP t_j to be encouraging]].

Thus, as long as Gapping is an option, the ECM data do not provide an independent argument that A-movement is not subject to the CSC.

Johnson's (1996) solution for the conflict between asymmetric A-movement and the CSC also runs into conceptual difficulties. On the one hand, Johnson wishes to maintain the absolute validity of the CSC, suggesting in particular that the CSC should correctly be grouped together

¹³ What I have labelled "XP" in (22), Johnson labels "IP," presumably non-finite IP/TP clauses.

with other movement-related constraints (see, e.g., Johnson's criticism of Zoerner's (1995) reformulation of the CSC; Johnson 1996: 26, FN 21). He invokes the CSC as the source of the ungrammaticality of sentences with asymmetric A-movement out of non-initial conjuncts.

(24) **CSC-violating Asymmetric A-movement**

a. * [TP **Nicole**_i scored_j; [VP₁ Lynne scored_i; one goal] and [VP₂ **t**_i scored_j; two goals]]. (cf. (16))



b. * Mary made **Lukas**_i out [XP [XP₁ Reggie to be intelligent] and [XP₂ **t**_i to be kind]].



(based on Johnson 1996: ex. 70)

On the other hand, asymmetric A-movement out of initial conjuncts must be exempted from the CSC. Johnson offers no explanation for why the CSC may be violated in some cases, but not others.

In Chapter 4, I consider another possibility, namely, that the CSC is not actually being violated in the case of asymmetric A-movement. I argue for an updated version of the CSC that treats it not as an autonomous constraint, but as a consequence of a particular way of interpreting coordinate structures. Furthermore, I show that asymmetric A-movement behaves exactly as predicted, given this revised understanding of the CSC. In doing so, I undermine one of the most obvious objections to the Small-Conjunct Approach to Gapping: that it results in "extensive" violations of the CSC (Hartmann 2000: 155).^{14,15}

Returning to the second key element of Johnson's (1996) analysis of Gapping, let us consider the use of overt ATB movement as the primary mechanism for producing Gaps. As originally described, Johnson proposes to capture main verb Gapping via overt ATB movement of the verbs to T. However, requiring overt V-to-T movement in English challenges the well-supported conclusion that (lexical) verbs do not move overtly to T in English (as compared to,

¹⁴ In the remaining discussion in this chapter, as well as in Chapter 3, I assume that asymmetric A-movement does exist. The reader is asked to withhold any skepticism regarding asymmetric A-movement until Chapter 4.

¹⁵ Another question generated by the combination of VP-level coordination and asymmetric A-movement is how the second subject (or any non-initial subject) receives case. Johnson adopts Zoerner's (1995) proposal that the head of the coordination is able to assign (or license the assignment of) case. See Chapter 5, FN 20 for an alternative suggestion.

e.g., French; Pollock 1989). In addition, ATB head-movement cannot easily account for larger gaps, such as that in (25):

- (25) Christine wanted to learn how to shoot a wrist shot, and Jeanie ~~wanted to learn how to shoot~~ a slap shot.

In fact, the conclusion Johnson draws regarding the use of overt ATB movement is more complicated. In order to capture certain readings involving reconstructed adverbs, Johnson hypothesizes that Gapping may also involve overt ATB movement of larger constituents which he labels "Polarity Phrases" (PolP).¹⁶ According to Johnson, PolP contains T and V in English: PolP–T–V. Any phrase which wants to be a remnant must first scramble out of PolP before PolP undergoes overt ATB movement. And since the two (or more) PolPs undergoing ATB movement need a target to land on, Johnson also needs additional functional heads above the point of coordination. The result is a large number of functional heads needed in the tree, for which there is no independent evidence.

In the example derivation (26), coordination takes place at the "AgroP" level. In the second conjunct, the subject and object remnants *his guests* and *beans* scramble out of their VP (and containing PolP) by moving to Spec-Agro2. In the first conjunct, the object *caviar* moves to Spec-Agro1. The two PolPs undergo overt ATB movement, producing the Gapped lexical verb *eat*. The subject of the first conjunct, *Ward*, moves to Spec-Agr (presumably, the equivalent of the EPP feature on T is present on AgrP in Johnson's model). The T and Pol heads *can* and *n't* undergo head movement out of the ATB-moved PolP to Agr.

(26) **Sample Structure**

(Johnson 1996: 62, ex. 149)

- a. Ward can't eat caviar and his guests ~~can't eat~~ beans.

¹⁶ The specifics of Johnson's analysis are quite intricate, and will not be presented here. Refer to Johnson 1996: 54–65 for details.

b.

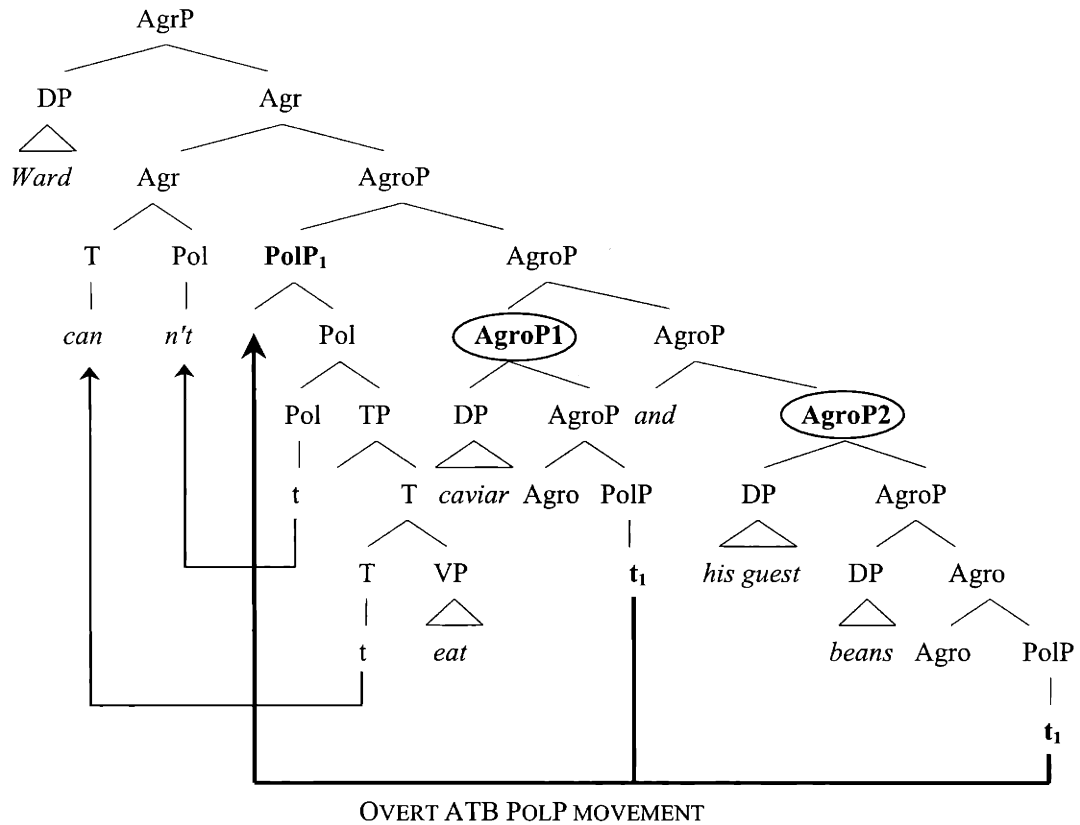

With the proper combinations of overt ATB and non-ATB movement, Johnson is able to handle most Gapping cases. In addition, by attributing the Gapping effect to ATB movement, which only occurs in coordinate contexts, Johnson's theory captures the dependency of Gapping upon coordination (cf. VP-ellipsis, which may take place outside of coordinate structures). Furthermore, Johnson's approach to Gapping encompasses Hankamer's Major Constituent Condition (1973, 1979), a descriptive generalization constraining the size of remnants. Among other things, remnants must be maximal projections. Since, in Johnson's analysis, remnants must move out of PolP in order to remain outside of the Gap, remnants will be maximal projections – that is, things which are subject to movement.¹⁷

Despite the advantages of Johnson's proposal, its use of overt ATB movement results in a number of word order problems that necessitate the adoption of many extra functional heads. I therefore offer a different analysis of the Gapping mechanism. My proposal relies on small-

conjunct structures and asymmetric A-movement, but does away with overt ATB movement (and its consequent need for extra functional heads) as the means for producing gaps.¹⁸ I present my proposal for Gapping in Chapter 3.

2.3 Summary: Sometimes Its Necessary to be Small

In this chapter, we have seen two basic approaches to the analysis of Gapping: the Large-Conjunct Approach and the Small-Conjunct Approach. Wide-scope modal sentences, wide-scope negation sentences, and cross-conjunct binding sentences provided evidence in favor of the existence of small-conjunct structures. Note that we have not presented any arguments against the existence of large-conjunct structures. All we have shown is that the Small-Conjunct Approach fares better than the Large-Conjunct Approach in the analysis of a subset of Gapping constructions; and to the extent that the analyses presented are correct, this constitutes evidence in favor of the Small-Conjunct Approach.

¹⁷ I leave as an open question whether the possibility of head movement within a Johnson-style approach to Gapping may lead to results that violate the Major Constituent Condition.

¹⁸ Note that asymmetric A-movement is an almost inevitable product of small-conjunct coordination and the VP-internal Subject Hypothesis (cf. FN 10). As such, this particular aspect of Johnson's proposal should be generalized to any Small-Conjunct Approach to Gapping. In contrast, the second key element of Johnson's proposal, overt ATB movement, is not a necessary consequence of the Small-Conjunct Approach.

3. The Interpretation of Shared Structures at PF: Sharing and Gapping

In the previous chapter, we saw that the assumption of small-conjunct structures provides a natural account for a class of sentences: wide-scope modal sentences, wide-scope negation sentences, and cross-conjunct binding sentences. What these three types of sentences have in common is a feature I call *necessary T-sharing* (Lin 2000): the requirement that a single T appear in the structure above coordinated VPs. This T (as well as the rest of the structure sitting above coordination) is "shared" by the conjuncts, and determines the temporal properties (e.g., the time of evaluation) for each conjunct.¹ For the examples discussed, T-sharing is "necessary" because coordination below the shared T yields the structure that is crucially needed for a left-peripheral element – a modal operator, negation, or a variable binder, in our examples – to take scope over the conjuncts.

From a Large-Conjunct perspective, it looks as if T-sharing sentences are missing elements in non-initial conjuncts. It was in consideration of this perspective that I grouped T-sharing sentences together with canonical instances of Gapping at the start of Chapter 2. However, nothing actually needs to Gap (i.e., be elided) in T-sharing sentences (1).

(1) T-Sharing Sentences, Nothing Gapped

a. Wide-Scope Modal

Alicia_i can't [_{VP1} t_i drop-pass on the right] and [_{VP2} Wendy shoot from the left].

b. Wide-Scope Negation

Sarah_i didn't [_{VP1} t_i skate on Saturday], or [_{VP2} Samantha skate on Sunday].

c. Cross-Conjunct Binding

Not every girl_j will [_{VP1} t_j purchase a hat] and [_{VP2} her_j brother buy a sweatshirt].

As we will see in this chapter, Sharing and Gapping are two different things: "Sharing" describes a particular type of syntactic structure which involves material above the point of

¹ See Chapter 2, FN 7.

coordination that is relevant for the interpretation of each conjunct (henceforth *shared material*); and "Gapping," it will be argued, is a deletion operation which applies within sharing structures.

The analysis of Gapping as the result of a deletion process has a long tradition, starting with Ross (1967) himself (see van Oirsouw 1987 for a historical overview of this approach). Because most deletion approaches to Gapping have attempted to unify it with other types of ellipsis phenomena, one common mode of argument against a deletion approach to Gapping is to show how Gapping differs from other ellipsis processes, and how the deletion proposal fails to correctly account for these differences (see Levin 1979, Johnson 1996, 2001 on differences between Gapping and VP ellipsis, and arguments for why Gapping cannot be reduced to a VP-ellipsis based approach). Of particular importance for our proposal is the fact that Gapping is restricted to coordinate structures, while VP ellipsis and Pseudogapping are not (Jackendoff 1972, Hudson 1976).

(2) **Non-Coordinate Structures**

a. **VP Ellipsis – OK**

- i. Bruce back-checked quickly. Brenda did too.
- ii. Bruce back-checked quickly after Brenda did.

b. **Pseudogapping – OK**

- i. (First) Bruce stopped the right-wing player. (Then) Brenda did, the left-wing player.
- ii. Bruce stopped the right-wing player after Brenda did, the left-wing player.

c. **Gapping – Ungrammatical**

- i. *(First) Bruce stopped the right-wing player. (Then) Brenda, the left-wing player.
- ii. *Bruce stopped the right-wing player after Brenda, the left-wing player.

The deletion proposal offered here differs from many other deletion proposals by claiming that the deletion operation responsible for Gapping is dependent upon a particular structural configuration, one which relies upon coordination.² It makes no attempt to equate the deletion mechanism proposed for Gapping with that of other deletion processes, in particular, VP Ellipsis

² But cf. Williams 1997 (a base-generation approach to Gapping), and Ackema and Szendrői (to appear), whose theory of Dependent Ellipsis is based upon Williams' (1997) Coordinate Ellipsis. These theories actually build coordination into the definition of what can license base-generated null heads (i.e., Gaps).

and Pseudogapping. These other forms of ellipsis are treated as independent of Gapping, most notably because their licensing environments do not depend upon sharing (or upon coordinate structures, more generally). I will further suggest that, while these other forms of ellipsis are not dependent upon a sharing configuration, they are not barred from occurring in a sharing configuration, either. Thus, these other forms of ellipsis (Pseudogapping, in particular) may interact with small- and large-conjunct structures to produce sentences which look like Gapping sentences. Separating out some of the ways in which different deletion phenomena may interact with small- and large-conjunct structures is another one of the aims of this chapter.

In addition to proposing a theory of Gapping in this chapter, I will also examine more closely the interaction between Sharing and Gapping. I will show that, due to the possibility of different heights of coordination, as well as the availability of alternative deletion processes, such as VP Ellipsis, a sentence which is traditionally called a Gapping sentence may actually be given distinct parses. This fact is relevant for us because it alerts us to something which we will need to control for when discussing the properties of small-conjunct, and in particular T-sharing, structures.

The starting point for the discussion is a set of sentences discussed by Siegel (1984, 1987) which I refer to as *The Siegel Puzzle*. One desideratum for our theory of Gapping will be to provide an account for facts of the Siegel Puzzle, which is presented in Section 3.1. We will use the Siegel Puzzle as a means of framing our discussion. In Section 3.2, I introduce some generalizations regarding the patterns of deletion and interpretation in Gapping. In Section 3.3, I present a particular instantiation of the deletion operation which is applied in Gapping, and provide evidence in favor of the Gapping generalizations given in Section 3.2. In Section 3.4, I speculate on the nature of the Gapping operation, and in particular, on the reason for why Gapping takes place. We return to the Siegel Puzzle in Section 3.5, and end with conclusions and a caveat in Section 3.6.

3.1 Starting Point: The Siegel Puzzle

Siegel (1987) presents the paradigm in (3) (see also Siegel 1984, Oehrle 1987 for similar facts):

- | | | | |
|-----|----|---|---|
| (3) | a. | John can't eat caviar and Mary eat beans. | WIDE-SCOPE MODAL ONLY |
| | b. | John can't eat caviar and Mary can't eat beans. | DISTRIBUTED MODAL ONLY |
| | c. | John can't eat caviar and Mary, beans. | WIDE-SCOPE OR DISTRIBUTED
(Siegel 1987: 56, ex. 7–9) |

(3a) has only a wide-scope modal reading, which can be paraphrased as *It can't be the case that John eats caviar while Mary eats beans*. (3b) has only a distributed modal reading (what Siegel calls a *narrow scope* reading). (3c) is ambiguous; both the wide-scope and the distributed modal readings are possible.³ Crucially, the ambiguity of (3c) tells us that small-conjunct structures by themselves are unable to account for the entire range of interpretations and surface structures seen in the Siegel Puzzle paradigm. The possibility of having either of the two modal readings suggests that (3c) has two different underlying sources: (3a) for the wide-scope modal reading, and (3b) for the distributed modal reading. A large-conjunct structure will therefore be required for the distributed modal reading of (3c).⁴ Furthermore, some kind of ellipsis mechanism will be needed to derive the surface (i.e., pronounced) form (3c) from (3a) and (3b). The question arises: What is the mechanism for producing the Gaps?

- | | | |
|-----|----|---|
| (4) | a. | Wide-Scope Modal (Small-Conjunct Structure)
John can't eat caviar and Mary eat beans. |
| | b. | Distributed Modal (Large-Conjunct Structure)
John can't eat caviar and Mary can't eat beans. |

³ Oehrle (1987) points out that the two readings of sentences like (3c) can be brought out with different prosodies. In the case of the wide-scope modal reading, the sentence is uttered as a single intonational phrase, marked by having only one nuclear accent that appears on the final constituent, and by having no pause between the conjuncts; in the case of the distributed modal reading, the sentence is read as two intonational phrases, each conjunct containing its own nuclear accent, and the conjuncts being separated by an intonational pause (Oehrle 1987: 206–207).

⁴ In Chapter 2, we saw arguments in favor of the existence of small-conjunct structures. As we have noted, such arguments do not preclude the existence of large-conjunct structures as well.

In the following subsections, I outline a proposal for Gapping which consists of: a description of the structural environment in which Gapping takes place (Section 3.2); generalizations regarding patterns of deletion (Section 3.2); and a deletion operation that produces Gaps (Section 3.3). I will suggest that this deletion operation may only apply when certain conditions are met – in other words, that the deletion operation requires a trigger for application (Section 3.4).

3.2 Gapping Generalizations

In this section, I define some generalizations which appear to hold of deletion and interpretation patterns in Gapping. Specific examples illustrating how these generalizations work will be given in Section 3.3.

First, it is crucial to bear in mind that coordination can take place at different points in a clause. We have seen at least two: what we have been referring to as "small-conjunct structures" are basically ν P-level coordinations (under a shared T); and what we have been referring to as "large-conjunct structures" are minimally TP-level coordinations. In Chapter 2 we saw scope and binding diagnostics for small-conjunct versus large-conjunct size.⁵

Second, Gapping is proposed to be the result of a deletion operation which applies only in sharing configurations.⁶ I refer to this as the *Sharing Requirement on Gapping*, and illustrate it in (5).

⁵ Schwarz (1999) concludes that the location of *either* in an *either...or...* construction serves to mark the left edge of the first disjunct (contra Larson 1985). If his analysis is correct, we will have another diagnostic for conjunct/disjunct size. As far as I can tell, the use of *either* as another diagnostic for conjunct size will not affect the analysis being presented; however, I have not yet investigated this thoroughly. (Thanks to Kyle Johnson for pointing out to me the potential significance of Schwarz's analysis.)

⁶ Johnson's approach to Gapping also seeks to capitalize on the notion of "sharing." Johnson's implementation is quite different, however. For Johnson, a shared node is required as the target for ATB movement.

(5) **Sharing Configuration Required for Gapping**

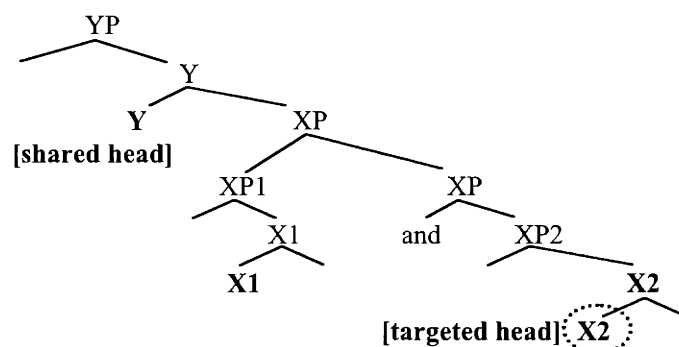

For a head to be targeted for deletion, it must be the highest head (X2) in a non-initial conjunct (XP2) sitting below shared material (e.g., Y).⁷ (Set aside for now the question of how the deletion site is created; we address this issue in Section 3.3.)

Third, I suggest that Gapping is subject to the following two generalizations regarding the size of the deletion site:

(6) **Deletion Site Generalizations**

a. *Highest Head Generalization*⁸

When a head X is deleted as part of a deletion site, the first head c-commanding X that is not deleted must be a coordinate head.

b. *Chain of Deletion Generalization*⁹

If a head X is targeted for Gapping, then all of the heads in its maximal s-projection set (Abney 1998; cf. Grimshaw's (1991, 2000) notion of "Extended Projection") must also be included in the deletion site.

⁷ As it has been stated in (5), the Highest Head Generalization is not sufficient to account for Gapping in coordinate structures containing three or more conjuncts. For example, something additional is needed to account for the pronunciation versus non-pronunciation of the various conjunct heads. I will not address this issue, however.

⁸ I am grateful to Danny Fox for his guidance in the formulation of this condition.

⁹ Cf. Williams' (1997) theory of coordinate ellipsis, in which he makes the generalization that "a [null] head *can* license [null] complements" (Williams 1997: 622; emphasis mine), subject to certain independent rules of anaphora. The necessary nature of the deletion operation described in (6b) also contrasts with Wilder's (1994, 1997) *Head Condition*, which states that "an ellipsis site may not be c-commanded by an overt (non-deleted) head in its domain (= conjunct)" (Wilder 1997: 74, ex. 54), and with Hartmann's (2000) proposal that Gapping only requires deletion of

Again, the details of the deletion operation will be discussed in Section 3.3. For now, it is sufficient to illustrate how the Highest Head Generalization applies in a sharing configuration. Returning to the structure in (5), the Highest Head Generalization tells us that the first non-deleted head c-commanding the deleted head X2 must be a coordinate head (e.g., *and*).

The set of heads for which the Chain of Deletion Generalization applies can be characterized in terms of Abney's (1987) *s-projection*. Abney's s-projection is defined in terms of *functional selection* – the relationship between a functional head and its complement. (Functional selection contrasts with the relationship between a non-functional head and its complement – a *thematic relation*; Abney 1987: 54–56). According to Abney, the hallmark of functional selection is a semantic characteristic which he calls "the 'passing on' of the descriptive content of [the complements of functional heads]" (Abney 1987: 55). Abney uses the notion of functional selection to define *s-projections*: the s-projection of a node is "the path of nodes along which its descriptive content is 'passed along' " (Abney 1987: 57). Abney's formal definition of s-projection (see Abney 1987: 57, ex. 47) tells us that the maximal s-projection of C is CP; the maximal s-projection of T is CP; and the maximal s-projection of V is CP. The *maximal s-projection set* of a V in an embedded clause is illustrated in (7).

non-initial Cs; after that, verbs *may* be dropped, as long as certain prosodic conditions have been met (Hartmann 2000: 170–172).

(7) **Maximal s-projection set of the embedded V** (adapted from Abney 1987: 58, ex. 48)

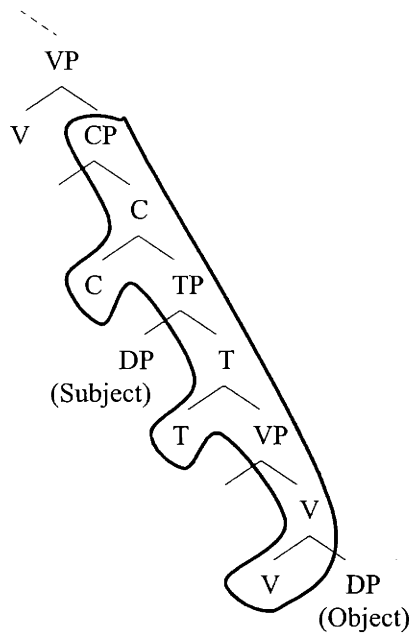

It is to the heads belonging to this maximal s-projection set that the Chain of Deletion Generalization applies.

In the next section, we will discuss details of the deletion operation applied in Gapping, and we will see specific examples that provide evidence in favor of the proposed Gapping generalizations.

3.3 Dealing with Deletion

In the previous subsection, we characterized Gapping as an operation which affects a particular head in a sharing configuration. We did not specify how the targeted head is actually deleted, however. In principle, there are at least two different ways of deleting the targeted head. One is to delete the head as part of a larger deletion site, such as the entire XP containing X (the target of deletion). Another is to target and delete the head directly. Both of these approaches require the adoption of additional assumptions, and I do not yet have evidence for choosing between one or the other approach. For the sake of exposition, I will assume in this chapter (and

in the remainder of this thesis) that the deletion operation (in Gapping) targets heads directly; that is, I will assume that Gapping is produced by the deletion of heads. (The alternative approach, to treat Gapping as the result of deletion of XPs, will be outlined briefly Section 3.3.3.) While the decision to pursue one particular approach over another will affect the set of assumptions that needs to be adopted, it will not change the deletion site generalizations stated in the previous section, namely, the Highest Head Generalization and the Chain of Deletion Generalization; nor will it affect the Sharing Requirement on Gapping.

Recall that the Sharing Requirement on Gapping restricts deletion to the highest head in a non-initial conjunct sitting under shared material. Adopting the view that the deletion operation applies to heads, this means that X2 in the structure in (5) (repeated as (8)) will be targeted for deletion (by which I mean deletion at PF):

(8) **Sharing Configuration Required for Gapping**

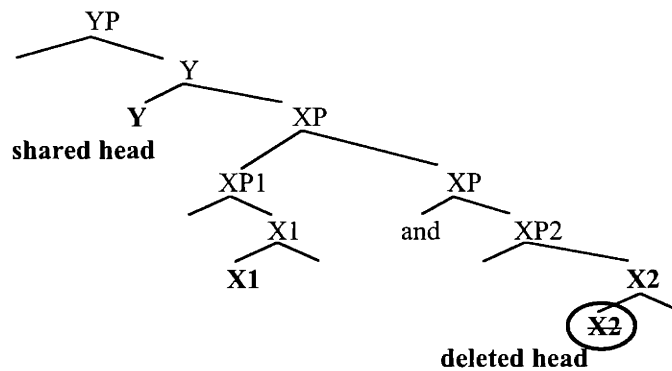

In fact, this correctly characterizes the wide-scope modal reading of the sentence in (4a), repeated here as (9):

(9) a. **Wide-Scope Modal (Small-Conjunct Structure)**

John can't eat caviar and Mary eat beans.

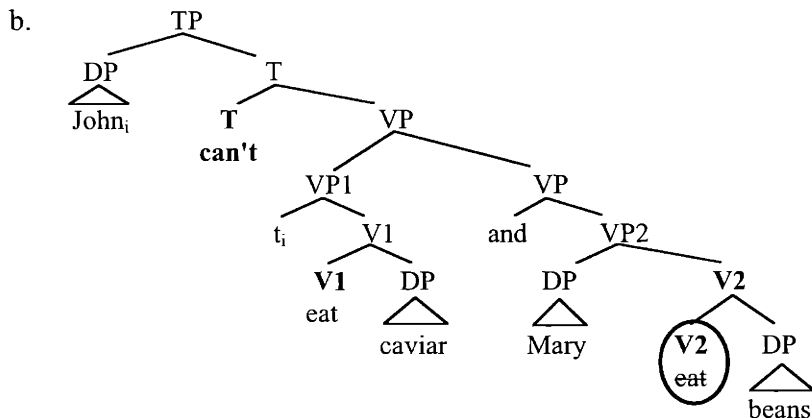

Given the assumption that Gaps are formed via deletion of heads sitting in particular structural environments, we will consider in the next two subsections evidence in favor of the deletion site generalizations posited in Section 3.2, namely, the Highest Head Generalization and the Obligatory Sharing Generalization, refining them where necessary.

3.3.1 The Highest Head Generalization

In this subsection, we examine the evidence in favor of the Highest Head Generalization (6a), repeated as (10) (with minor modification, in light our assumption that deletion in Gapping targets heads).

(10) **Highest Head Generalization**

When a head X is deleted, the first head c-commanding X that is not deleted must be a coordinate head.

We begin the discussion with an old observation (Fiengo 1974: 121; see also Neijt 1979) that Gapping cannot take place in coordinated CPs (when all Cs are overtly pronounced):¹⁰

¹⁰ This observation is not without potential counter-examples. In (i), for example, each conjunct contains a WH-phrase. Assuming WH-phrases move overtly to Spec-C in English, (i) suggests that two CPs are being conjoined. (i) B asked [which books I gave to Mary] and [which records to John]. (Johnson 1996: 68, ex. 162; cited from Pesetsky 1982: 646, ex. 126)

However, López and Winkler (2001) argue that sentences like (i) involve small-conjunct coordination, with the second WH-phrase sitting in Spec-v. Their argument utilizes wide-scope negation. By combining (i) with wide-scope negation, they force the second conjunct to be VP-sized:

- (11) a. *[_{CP} If [_{TP} Gene won't play the guitar] and [_{CP} if [_{TP} Erik ~~won't play~~ the bass]]]...
 b. *Mary said [_{CP} that [_{TP} Gene can play the guitar] and [_{CP} that [_{TP} Erik ~~can play~~ the bass]].

If coordination takes place below a shared C (indicated in bold), Gapping is fine:

- (12) a. [_{CP} **If** [_{TP} Gene won't play the guitar] and [_{TP} Erik ~~won't play~~ the bass]]...
 b. Mary said [_{CP} **that** [_{TP} Gene can play the guitar] and [_{TP} Erik ~~can play~~ the bass]].

I have assumed that C-sharing is involved in the sentences in (12). In fact, when we consider (12b) more carefully, we see that it can also be analyzed as sharing of the higher root verb *said* which produces the environment for Gapping *that* in the second C:¹¹ (For now, set aside the question of how *can* and *play* are deleted.)

(ii) Bill asked which books we didn't give to Mary or which records to John. (López and Winkler 2001: 24, ex. 30a) The conclusion they draw – that the second WH-phrase *which records* is in Spec-*v* – is not necessarily warranted, however. In this particular example, it may also be the case that the second WH-phrase is sitting in situ. But cf. (iii), which utilizes the phrase *...the hell...*, which has been argued by Pesetsky (1987) to be incompatible with WH-in-situ:

(iii) Bill asked how the hell many books I gave to Mary and how the hell many records to John.

If (iii) is grammatical, the possibility of WH-in-situ is then ruled out, in which case, the second WH-phrase *how the hell many records* may be sitting in Spec-*v*. (Thanks to David Pesetsky for pointing out this type of example to me.)

The main point stands: the example in (i) is compatible with a structure other than CP-level coordination, and therefore does not present a counterexample to the observation that Gapping is not allowed in conjoined CPs (where all Cs are pronounced).

¹¹ I assume that, independent of the theory of Gapping, it is possible for English declarative C to be realized as *that* or as a null element. In some instances of Gapping, it will therefore be difficult to tell whether C is not being pronounced because it is a null element or because it has been Gapped. The consequence of this for our discussion is a weakening of the evidence being presented.

(13) a.

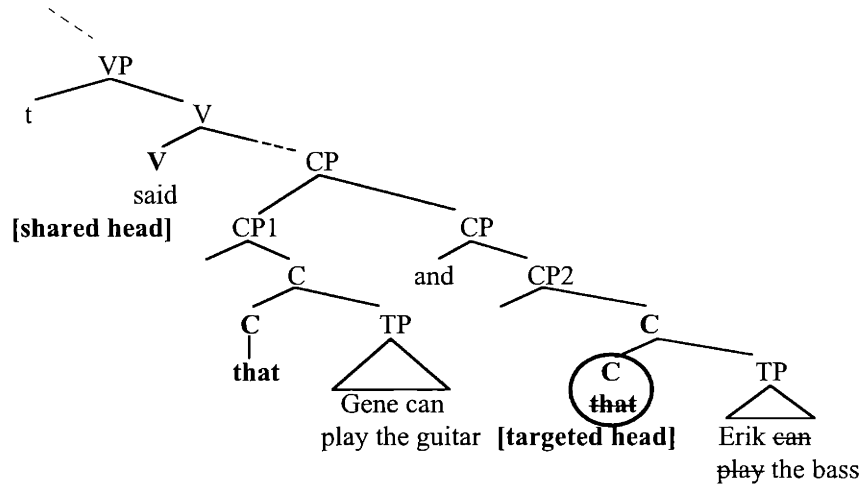

b. Mary said [_{CP} that Gene can play the guitar] and [_{CP} that Erik can play the bass].

At this point, we have no means of distinguishing between the two parses in (12b) and (13b).¹² I assume both are possible.¹³

If (13b) is a valid parse, then the ban on Gapping in coordinated CPs must be reevaluated. In fact, the effect of the original ban falls out as a natural consequence of the proposed Gapping generalizations : the sentences in (11) are ungrammatical because they do not conform to the Highest Head Generalization. In order to conform to the Highest Head Generalization, the first non-deleted head c-commanding the highest deleted heads of the non-initial conjuncts, the T hosting *won't* in (11a) and the T hosting *can* in (11b), must be a coordinate head. However, the relevant c-commanding heads are the C hosting *if* in (11a) and the C hosting *that* in (11b). The

¹² It may be possible to identify the difference between the two possible structures using the scope of an element in C (e.g., the conditional *if*) relative to the coordination. That is, we would predict a meaning difference between (i) and (ii):

(i) if [[_{TP} A] and [_{TP} B]]

(ii) [_{CP} if A] and [_{CP} if-B]

If both parses are available, we would predict (iii) to be ambiguous:

(iii) I need to know if Gene can play the guitar and Erik can play the bass.

Judgments are subtle, however, and require further investigation.

¹³ As pointed out to me by Norvin Richards, there is evidence for the structure in (12b), which is independently needed for sentences like (i):

(i) [_{CP} **That** [_{TP} Gene can play the guitar] and [_{TP} Erik ~~can~~ play the bass]] is perfectly obvious.

Highest Head Generalization correctly characterizes the deletion patterns in (11) as ungrammatical.¹⁴

In a similar vein, if CPs are coordinated under a higher V, deletion of C is grammatical (13). However, if higher VPs are coordinated, and the highest head deleted is the head of the embedded CP, the result is ungrammatical, as expected (14b).

(14) Coordinated VPs with Embedded CPs

a. No Gapping

Jaemin will [_{VP} ask [_{CP} if Joe can play the bassoon]]
and [_{VP} find out [_{CP} if Petra can play the horn]].

b. Gapping applied to C (= ungrammatical)

* Jaemin will [_{VP} ask [_{CP} if Joe can play the bassoon]]
and [_{VP} find out [_{CP} if Petra ~~can~~ play the horn]]. (based on Pesetsky 1999: ex. 70b)

The original observation, that Gapping is banned in coordinated CPs, can thus be subsumed under the Highest Head Generalization.¹⁵

3.3.2 The Chain of Deletion Generalization

To see the effects of the Chain of Deletion Generalization (6a), repeated as (15) (with minor revision), consider a wide-scope modal sentence (16):

(15) Chain of Deletion Generalization

If a head X is targeted for Gapping, then all of the heads in its maximal s-projection set must also be deleted.

¹⁴ As we have stated it, the Highest Head Generalization might lead us to expect a difference between Gapping in conjoined CPs headed by *if*, versus Gapping in conjoined CPs marked by *whether*. In particular, we would expect Gapping in a *whether*-clause to be grammatical, if the C of the non-initial conjunct can be deleted:

(i) *I need to know [whether Gene can play the guitar] and [whether ~~can~~ Erik can play the bass].

However, Gapping in a *whether*-clause seems just as bad as Gapping in an *if*-clause. (Thanks to Norvin Richards for pointing this out to me.) I do not yet have an explanation for this fact.

¹⁵ The theory proposed in Williams 1997 is also able to capture the general observation that, if deletion takes place, the highest head in the conjunct must be included in the Gap. However, Williams' theory does not account for the effects of the Obligatory Sharing Generalization, which we turn to next.

(16) Katherine can't play the guitar and Joelle play the bass.

Recall that such sentences have exclusively a wide-scope modal interpretation. (16) states that the conjunction of two propositions, Katherine playing the guitar, and Joelle playing the bass, cannot take place. It says nothing about the possibility of individual propositions: Katherine may very well be able to play the guitar, and independently, Joelle may very well be able to play the bass. The exclusivity of the wide-scope modal reading provides us with an important clue as to what syntactic derivation is not possible. Specifically, it must be impossible to simply delete T. If deletion of just the elements contained in T were a valid operation, we would expect the following derivation to be possible for (16), starting with a large-conjunct/distributed modal underlying structure:

(17) # $[_{CP} \emptyset [_{TP} \text{Katherine can't play the guitar}] \text{ and } [_{TP} \text{Joelle can't play the bass}]]$.¹⁶

But if (17) were interpretable, it would incorrectly predict that (16) should have a distributed modal reading. Thus, the derivation in (17) must be blocked. The Chain of Deletion Generalization captures the ill-formedness of (17): if *can't* is deleted, every head in the maximal s-projection set containing *can't* must be deleted as well. In this example, *play* must be deleted in order to conform to the Chain of Deletion Generalization; indeed, if *play* is deleted, the sentence is grammatical and has a distributed modal interpretation, as expected.

(18) $[_{CP} \emptyset [_{TP} \text{Katherine can't play the guitar}] \text{ and } [_{TP} \text{Joelle can't play the bass}]]$.

We can see more evidence in favor of the Chain of Deletion Generalization when we consider sentences with more material occupying the stretch between T and V. Consider first the following pair of sentences:

¹⁶ Given our claim that Gapping only takes place in sharing structures, it must be the case in example (17) that a null C (indicated by " \emptyset ") is being shared.

- (19) a. The visiting team can't be changing on the benches and the home team can't be changing in the locker room.
- b. The visiting team can't be changing on the benches and the home team ~~can't be changing~~ in the locker room.

To keep the discussion clear, I will refer to the node hosting *be* in these examples as BE, and the node hosting *changing* as ING; these head BE-Phrases (BE-P) and ING-phrases (ING-P), respectively.

The sentence in (19a) has only a distributed modal reading. Assume for it a structure which satisfies the Sharing Requirement on Gapping: TP-level coordination under a shared C (where the shared C is null). When Gapping is applied to this structure, the highest node in the non-initial conjunct (T, hosting *can't*) deletes. The Chain of Deletion Generalization tells us that the remaining heads in the maximal s-projection set – BE and ING (as well as *v* and *V*) – must also delete. The outcome of Gapping applied to (19a) is (19b). As predicted, (19b) has the distributed modal reading.¹⁷

Compare (19) to the following pair of sentences:

- (20) a. The visiting team can't be changing on the benches and the home team be changing in the locker room.
- b. (?)The visiting team can't be changing on the benches and the home team changing in the locker room.

Neither of the sentences in (20) has the distributed modal reading; only a wide-scope modal reading is possible. According to the reasoning outlined above, this is because neither of the sentences in (20) may be derived via Gapping from a large-conjunct structure (e.g., TP-level coordination). In both (20a) and (20b), different heads within the maximal s-projection set are being pronounced. The Chain of Deletion Generalization tells us that T must therefore be being shared. (If T were missing from the non-initial conjuncts because it had been deleted, rather than shared in the structure, then the sentences in (20) would not conform to the Chain of Deletion Generalization.) The only possible structure for (20a) is a sharing structure with BE-P level

¹⁷ In fact, (19b) is ambiguous, as we will discuss below.

coordination under a shared T; similarly, the only possible structure for (20b) is a sharing structure with ING-level coordination under a shared BE. In both cases, the negative-plus-modal *can't* sits above the coordination, and can therefore only be interpreted as having wide scope.

- (21) a. The visiting team_i can't [_{BE} t_i be changing on the benches] and [_{BE} the home team be changing in the locker room].
- b. (?)The visiting team_i can't be [_{ING} t_i changing on the benches] and [_{ING} the home team changing in the locker room].

Of course, Gapping may also be applied to the sharing configurations in (21). In (21a), Gapping will delete *be*, and the Chain of Deletion Generalization will require deletion of *changing* as well. In (21b), Gapping will delete *changing*. Both cases result in the same pronounced form:

- (22) The visiting team can't be changing on the benches and the home team in the locker room.

which is also the same as (19b). The ambiguity of (22) is exactly what we expect, given the various possible derivations from different underlying sources.

3.3.3 XP-Deletion versus X-Deletion: An Alternative Approach

As mentioned at the start of Section 3.3, there is a logical alternative to X-deletion as the means of getting rid of a targeted head X at PF, namely, XP-deletion, where an entire XP containing the targeted head X is deleted. This approach would share similarities with the analysis of Pseudogapping proposed by Jayaseelan (1990), who argued that Pseudogapping is the result of moving an object NP out of a VP (via rightward movement) prior to VP deletion (23). In an example with a Gapped finite verb (24), the XP being targeted by Gapping must (minimally) be a TP; deletion of TP must be preceded by remnant movement of the subject and object to positions outside of it.

(23) **Pseudogapping (Jayaseelan 1990)**

- a. Heather's mother can play the viola, and Heather's other mother can, the trumpet.
b. ...and [TP (Heather's other mother)_i can [VP ~~t_i play t_j] (the trumpet)_j].~~

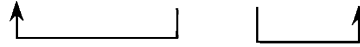

(24) **Gapping**

- a. Heather's mother can play the viola, and Heather's other mother – the trumpet.
b. ...and (Heather's other mother)_i [TP ~~t_i can play t_j] (the trumpet)_j].~~



This means that there must be TP-external positions to which the subject and object (or any other phrase which functions as a Gapping remnant) may move.¹⁸

Additionally, the XP-deletion approach to Gapping must block movement of VP (and other verb-related projections) prior to deletion. If movement of VP were allowed out of an XP targeted for deletion, the derivation in (25b) would be predicted to exist for the wide-scope modal sentence (25a):

- (25) a. Katherine can't play the guitar and Joelle play the bass.
b. # ...and (Joelle)_i [TP ~~t_i can't [VP t_j]] (play the bass)_j].~~



However, the derivation in (25b) makes the wrong prediction regarding the possible interpretation of (25a). In order to block derivations like (25b), we must assume that the VP cannot move out of the TP targeted for deletion.

Note that under the X-deletion approach, it is not as clear whether or not VP movement must be banned. Assuming that deletion of the set of heads in the relevant maximal s-projection may apply (in accordance with the Chain of Deletion Generalization) regardless of whether or not the heads are in their base-generated positions, then whether or not we require a ban on VP movement will depend on the direction (and landing site) of VP movement: If VP movement is

¹⁸ I have no claims to make regarding the type(s) of movement or the landing sites of movement that may be involved in remnant movement out of an XP which has been targeted for deletion. In (24b), I show the subject moving leftward, and the object, rightward, but nothing hinges crucially on the choice of direction or type of movement. (See Lasnik 2001, Baltin 2000 for other analyses of Pseudogapping that rely on remnant movement.)

to the right, no ban is necessary. If VP movement is to the left, however, the wrong surface word order may potentially result.

- (26) a. **VP movement to the right**
 [_{CP} Ø [_{TP} Katherine can't play the guitar] and [_{TP} Joelle ~~can't~~ [_{VP} t_j]] (~~play~~ the bass)_j
- b. **VP movement to the left**
 * [_{CP} Ø [_{TP} Katherine can't play the guitar] and (~~play~~ the bass)_j [_{TP} Joelle ~~can't~~ [_{VP} t_j]]

In contrast to the XP-deletion approach, which requires remnant movement (as well as landing sites for remnant movement) prior to deletion, as well as a ban on VP movement prior to deletion, the X-deletion approach requires a different set of assumptions. One assumption is that it is possible to delete a head. Since I assume that XP-deletion applies outside of Gapping (e.g., in VP Ellipsis and potentially also in Pseudogapping), the assumption that deletion may target an XP comes for free in the case of the XP-deletion approach. However, in the case of the X-deletion approach, there is no other independent evidence for a deletion operation which targets only a head. Thus, the assumption that X-deletion is possible is non-trivial. Furthermore, in contrast to the XP-deletion approach, the X-deletion approach requires reference to maximal s-projection sets in order to capture the effect of the Chain of Deletion Generalization. (Under an XP-deletion approach, the effect of the Chain of Deletion Generalization will fall out from the fact that deletion targets XPs, plus the ban on VP movement prior to XP deletion.)¹⁹

As stated earlier, I do not yet have enough evidence to commit to an XP- versus an X-deletion approach to Gapping. However, I have presented Gapping in terms of X-deletion, and will assume X-deletion throughout the remainder of the thesis.

¹⁹ Note that my reference to maximal s-projection sets in the original definition of the Chain of Deletion Generalization is purely for descriptive purposes; reference to maximal s-projection sets do not necessarily need to be incorporated into the conditions on the deletion operation used in Gapping.

3.4 Triggers for Deletion

One question raised by the proposal that Gapping be restricted to sharing configurations is: why should Gapping be dependent upon Sharing? In this subsection, I speculate that Gapping is the result of a deletion operation which is *triggered* in a particular structure, namely, in a sharing configuration.²⁰ The seed for the idea that a deletion operation might have a trigger comes from Lasnik's work on Pseudogapping and Sluicing (Lasnik 1995, 1999, 1999a, 2001). As we will discuss in Section 3.4.1, Lasnik's work on these other types of ellipsis constructions raises the possibility that triggers might be relevant for some cases of deletion. Lasnik examines scenarios in which structures which should be ungrammatical may be salvaged (i.e., saved from a derivational crash) if deletion takes place; this suggests that deletion may sometimes have salvation properties. I propose that some cases of deletion must have salvation properties – that is, that some cases of deletion must be triggered. In Section 3.4.2, I apply this idea specifically to the deletion operation responsible for Gapping, and suggest that it is this property of Gapping which may account for the availability of Gapping in a variety of languages which lack other types of deletion-related constructions (e.g., VP-ellipsis and Pseudogapping).

3.4.1 Deletion That May Be Triggered: Lasnik's Salvation By Deletion

Lasnik (1995, 1999, 1999a, 2001) suggests that PF deletion can be used to rescue structures which contain certain types of syntactic violations. Since the rescue operation requires

²⁰ It may also be possible to view Gapping as an operation which is licensed in a particular structural environment. For example, we could treat Gapping as the result of deletion licensed by a coordinate head. Under this approach, the deletion operation associated with Gapping would have to be an optional process, one which may apply if the proper licenser (e.g., the coordinate head *and*) is present. In contrast, adopting the view that Gapping is a triggered operation removes optionality from this point in the derivation (though it may introduce optionality elsewhere in the derivation) (see also FN 23). If Gapping is treated as a triggered operation, then whenever the trigger for deletion is present, deletion must take place. The analysis of Gapping presented in this chapter does not depend crucially upon either of these two views. Thus, while I adopt the view that Gapping is a triggered operation, and have made the proposed analysis of Gapping consistent with this assumption, it is also possible to treat Gapping as a licensed operation; the proposed analysis of Gapping would then require some minor revisions.

In theory, treating Gapping as a triggered versus a licensed operation should make different predictions. Specifically, we should be able to find environments in which Gapping must take place under the triggering view, but in which Gapping may apply optionally under the licensing view. If we can identify an environment in which Gapping must take place, this would constitute evidence in favor of the triggering view. In reality, however, it is difficult to identify such environments. (Among the issues which need to be addressed is one of conjunct size; since

removal of structure that contains the violation(s), this observation has come to be known as *Salvation By Deletion*. Lasnik specifically illustrates how *Salvation By Deletion* applies in the cases of Pseudogapping and Sluicing. In this subsection, we will only consider Lasnik's analysis of matrix Sluicing, since it alone provides potential evidence in favor of my proposal that some deletion operations require a trigger. (It is important to note that the inclusion of some summary of Lasnik's analyses should not necessarily be interpreted as an endorsement of the details of his approach; Lasnik's analyses of Pseudogapping and Sluicing are independent of the analysis of Gapping which is being presented in this chapter.)

Lasnik analyzes matrix Sluicing (27) as the result of WH-movement to Spec-C plus TP deletion.²¹

(27) **Matrix Sluicing**

(Speaker A: Ana will check someone.)

Speaker B : [_{CP} **Who**_i [_{TP} ~~Ana will check t_i~~]]? (based on Lasnik 2001: 6, ex. 10)

In English matrix WH-questions, at least two overt movements are normally required: (1) movement of the WH-phrase to Spec-C, and (2) movement of the lexical item in T to C. In order to drive the movement from T to C, Lasnik (2001) adopts the version of feature theory described in Chomsky 1995.²² In Chomsky 1995, the operation Move α is replaced with a "more principled operation," Move F (where "F" = a syntactic feature; Chomsky 1995: 262). The Move F operation is triggered by a strong feature F on a higher functional head (i.e., movement is triggered by a need of the attracting head; Chomsky 1995:233); and while movement of the formal feature F alone is enough to satisfy the need of the attracting head, considerations of PF convergence may require pied-piping of the other features associated with the moving F (resulting in overt movement).

coordination may take place at different heights, Gapped strings which look similar on the surface may actually have varying underlying sources, thus giving an illusion of optionality in the application of Gapping.)

²¹ The reader is referred to Lasnik 2001, citing Merchant 1999, for arguments that matrix Sluicing really does involve WH-movement followed by TP ellipsis (i.e., that a matrix Sluice is more than just a sentence fragment).

²² In his various papers on Pseudogapping, Lasnik employs different versions of feature theory. Thus, while Lasnik 1997 and Lasnik 2001 locate strong features on attracting heads (Chomsky 1995), Lasnik 1995 and Lasnik 1999a locate strong features on the items which undergo movement (Chomsky 1993). See Lasnik 1999 for a discussion and comparison of the various approaches.

In the case at hand, a strong feature F on C attracts a feature F on T. Lasnik hypothesizes that if only a subset of the attracted element's features moves – that is, if F alone moves, and pied-piping does not take place to join the pieces of the element in T back together at the C node – we are left with a "phonologically defective" item which will cause a crash at PF (Lasnik 2001: 4–5, adopting proposals of Ochi 1999). He proposes that the crash may be avoided if the offender, the defective item in T, is deleted. Specifically, Lasnik invokes TP ellipsis (= PF deletion of TP) to get rid of the TP that contains the offending item. The structure is thereby saved from a fatal crash at PF.

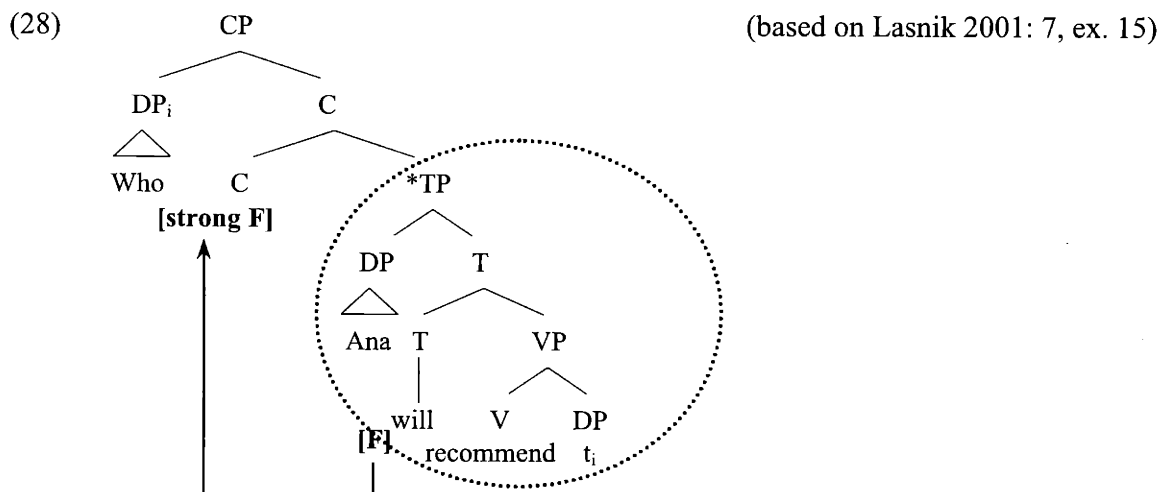

In Lasnik's analysis of matrix Sluicing (and similarly, in his analysis of Pseudogapping and Sluicing in embedded islands), we thus see that structures which contain syntactic violations may function as triggers for deletion. I suggest taking an additional step, and make the claim that deletion – at least in some cases – is a process which requires a trigger. On this view, deletion would be a last-resort operation, one which may only be invoked in a last-ditch effort to save an otherwise doomed derivation. If nothing goes wrong during the syntactic derivation, deletion should not apply. Instead of being optional (as in the traditional view of ellipsis), deletion in these cases may only apply when necessary.²³

²³ On issues related to optionality in another area of the grammar, see, for example, recent proposals that reanalyze the apparent optionality of certain movements (e.g., Rooryck 1994, Martins 1995 on clitic climbing; Miyagawa 1997, Neeleman and Reinhart 1998, Bošković and Takahashi 1998, Bailyn 2001, Fanselow 2001 on scrambling;

For a potential argument in favor of this claim, consider again the case of matrix Sluicing ((27), repeated as (29)):

(29) **Matrix Sluicing**

(Speaker A: Ana will recommend someone.)

Speaker B : [_{CP} **Who** [_{TP} Ana will recommend]]?

Recall that the "trigger" for deletion in this example is the phonologically defective T, *will*, which has failed to undergo necessary pied-piping. Ellipsis of the TP prevents the structure from crashing. As Lasnik (1999: 207, FN. 14) notes, if pied-piping does take place when T raises to C, TP ellipsis is ungrammatical:

(30) (Speaker A: Ana will recommend someone.)

Speaker B : *[_{CP} **Who will**_i [_{TP} Ana t_i recommend]]?

↑

In another paper, Lasnik (1999a) attempts to deal with this by suggesting the following generalization:

(31) XP ellipsis is prohibited if XP has lost its head. (Lasnik 1999a: 158, ex. 57)

But Lasnik is forced to give this generalization up in the face of VP ellipsis facts in languages with overt V-to-T raising. For some such languages, it has been argued by various researchers that VP ellipsis is possible after overt V-to-T raising, with everything inside VP except the V being deleted (Doron 1990 on Hebrew, McCloskey 1990 on Irish, and Martins 1994 on Portuguese, cited in Larson 1999a). If this type of analysis is correct, the generalization in (31) must be wrong. In order to capture the effects of the generalization in (31), which seems to hold true at least for English, Lasnik appeals to a line of research into licensing conditions on VP ellipsis (e.g., Zagona 1982, Lobeck 1990, Saito and Murasugi 1990), speculating that such an approach may prove fruitful, despite its crucial reliance on notions such as *government* and *Spec-*

Bošković 1998, Cole and Hermon 1998, Denham 2000 on wh-movement; see also Poole 1996).

Head agreement, which no longer have a role in much other work (see Lasnik 1999a: 157–161; cf. Lasnik 1999).

My proposal would relieve us of the burden of needing to explain *government* and *Spec-Head agreement* effects.²⁴ Rather than treating (30) as a puzzle whose solution lies in finding the right way of constraining the application of ellipsis, we can view (30) instead as evidence that ellipsis can't apply when it doesn't have to. Because the unelided version of (30) can be derived without incurring any syntactic violations, deletion will not be triggered. In fact, it's the overapplication of deletion in (30) that leads to ungrammaticality.

3.4.2 Deletion That Must Be Triggered: Gapping in Shared Structures

In the previous subsection, we saw that it was possible to interpret Salvation By Deletion as a motivation for the application of ellipsis. We also saw data from matrix Sluicing which could be interpreted as evidence that some deletion operations require a trigger for application.²⁵ In this subsection, I transplant this idea from the Sluicing domain to the Gapping domain, and suggest that Gapping is a deletion operation which requires a trigger for application.

Consider again the case of the wide-scope modal sentence.

(32) Katherine can't play the guitar and Joelle play the bass.

In Chapter 2, wide-scope modal sentences were argued to have the small-conjunct structure in (33).

²⁴ At least in terms of finding a trigger for deletion in the English Sluicing (and Pseudogapping) cases. The actual effects themselves must still be explained, of course.

²⁵ Whether or not this view of deletion as requiring a trigger for application can be applied to all cases of Pseudogapping and Sluicing remains an open question. Of particular importance will be those cases of Sluicing which are not discussed in Lasnik's work – i.e., cases of Sluicing in embedded clauses which do not constitute islands – since it is less obvious what syntactic violation may be triggering the ellipsis operation in these cases.

(33)

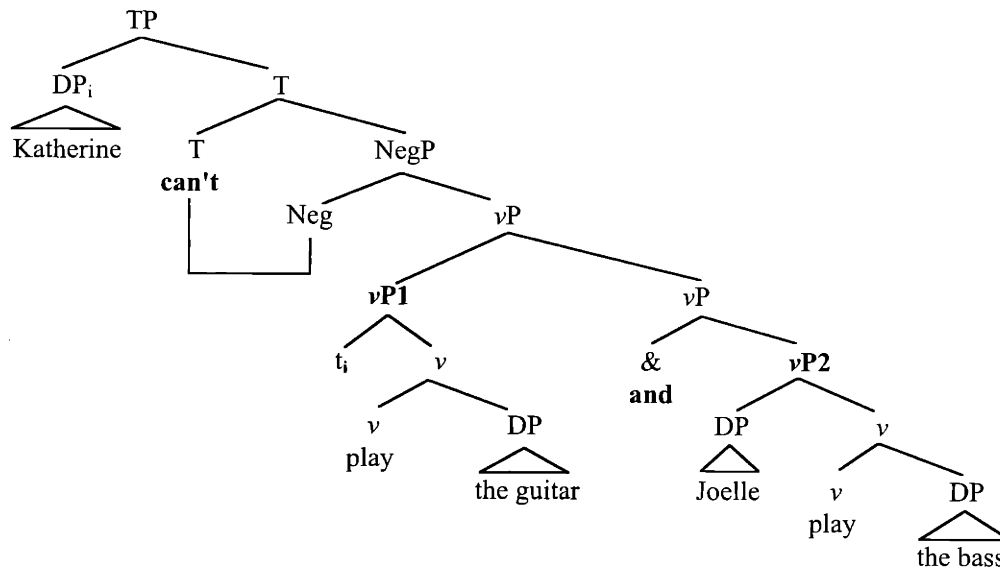

Given the existence of the T-sharing structure, consider now a case of small-conjunct coordination in which a bound morpheme occupies the shared T node in the tree:

(34) a. *Katherine played the guitar and Joelle play the bass.

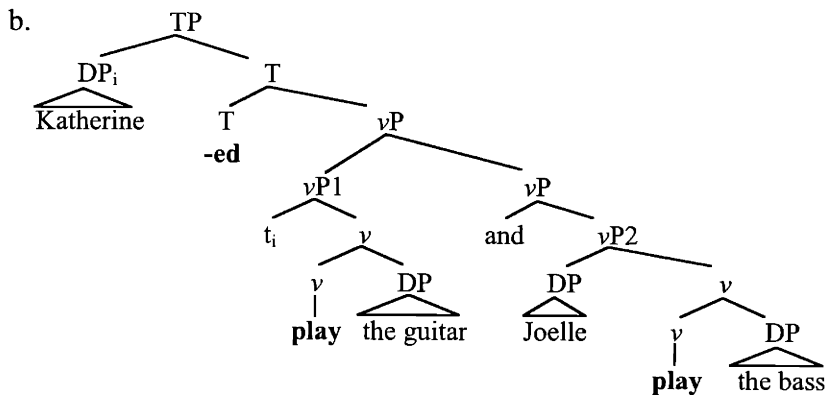

It is not immediately obvious why (34a) should be ungrammatical. Assuming that the bound morpheme *-ed* is subject to a morpho-phonological requirement that demands that it be properly affixed to (or morphologically merged with) an appropriate lexical host by PF (e.g., Bobaljik 1995, Embick and Noyer 2001; cf. Lasnik's (1981) Stranded Affix Filter), we might expect (34)

to be perfectly grammatical. The morpho-phonological requirement of *-ed* should be satisfied by the affixation of *-ed* onto the first verb *play*. But the result is bad.

Given that (34b) is a possible structure, and given that the morpho-phonological requirement of *-ed* is satisfied in (34), we can infer from the ungrammaticality of (34a) that the second verb *play* is the locus of the problem. This inference receives support from the fact that removal of the problematic *play* (whether by XP- or X-deletion; I have illustrated using X-deletion, for expository purposes) leads to a grammatical sentence.

(35) a. Katherine played the guitar and Joelle **play** the bass.

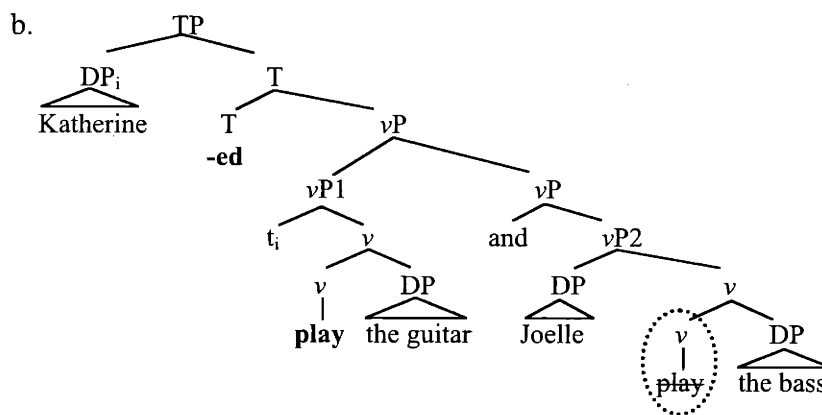

This looks like a Salvation By Deletion effect, since removal (via PF deletion) of the offending item saves the structure from ungrammaticality. What is it about *play*, or more generally, about the illustrated structure, which poses a problem for the success of the derivation? Contrast the ungrammatical (34) with (36), where T is not realized as an affix, and where both verbs are able to be pronounced:

(36) Katherine can't **play** the guitar and Joelle **play** the bass.

Since T is not an affix in this example, T does not need to enter into a special morphological configuration with either of the two verbs.

I speculate here that the trigger for deletion in this particular Gapping example stems from a Parallelism requirement on the highest head of each conjunct. In (34), the first instance of *play*

has entered into an exclusive relationship with the affix in T. Consequently, the two instances of *play* are in a non-parallel relation to one another, rendering the structure ungrammatical.²⁶ The non-parallelism between the two heads triggers deletion of the second instance of *play*.²⁷ In (36), in contrast, neither instance of the verb *play* enters into an exclusive relationship with T. Thus, no violations arise (in particular, the Parallelism requirement is satisfied), and no deletion is triggered. (I will address the issue of how the second *play* in (36) can come to be deleted in Section 3.5.)

This particular example locates the trigger for deletion in a failure to meet a kind of morphological Parallelism requirement. This Parallelism requirement need not be limited to the morphological domain, however. What is crucial for us is the scenario in which the highest head of each conjunct needs to establish some kind of relationship (whether mediated via features in the syntax, or by morphological properties in the post-syntactic component) with the shared head; and that when the shared head is unable to establish a relationship with every single one of the highest heads of in the conjuncts below it, a Parallelism requirement holding across the highest head of each conjunct will fail to be met. In such cases, deletion of X will apply in order to prevent the derivation from crashing.

In the Gapping examples we have discussed, I have implicitly assumed that the deletion operation associated with Gapping requires a trigger, and therefore, that some relationship is trying to be established between the shared head and the highest head of each conjunct. On this view, the existence of a sharing configuration alone is not enough to license Gapping. The

²⁶ Alternatively, we could express the difference between the two instances of *play* in terms of syntactic features: for example, the verbs and the single T could all have instances of a [+finite] feature. While one verb is sufficient to check or delete (or otherwise satisfy) the feature of T, the single T node is unable to do so for two different verbs. Note that if this approach is generally adopted for Gapping, it may not be necessary to invoke Parallelism. (Thanks to David Pesetsky for useful discussion of this point.)

²⁷ Why does the second instance of *play* delete, and not the first? The answer to this question may be related to the general observation that elements in first conjuncts generally do not delete. Along similar lines, we can also ask, why does the single affix merge with the first instance of *play*, and not the second? I suggest that the answer comes from the conditions which govern the process of morphological merger (the process that affixes *-ed* to a relevant head). In particular, affixation of *-ed* onto the first instance of *play* is predicted by Bobaljik's (1995) account of Morphological Merger under Adjacency.

(It would appear that Embick and Noyer's (2001) reformulation of Morphological Merger under Adjacency runs into trouble with respect to T-sharing structures. On their analysis, (affixal) T needs to establish a relationship with the head of its complement, *v*, via Lowering, which they define in hierarchical terms (Embick and Noyer 2001: 561). In a T-sharing structure, however, the head of T's complement appears to be *and* (this holds true in a variety of different analyses of the structure of coordination). Thus, their definition of Lowering incorrectly predicts that *-ed* will Lower onto *and* in T-sharing structures.)

inability of the shared head to establish a one-to-many relationship with the heads below is the trigger for Gapping. For the most part, nothing hinges on the assumption that Gapping is triggered (rather than licensed – cf. FN 20). We will discuss a case in which the issue does arise in the next section, however.

As a final note, the proposal that Gapping is a triggered operation requiring a specific syntactic environment may play a central role in distinguishing the deletion operation applied in Gapping from deletion operations applied elsewhere – for example, in VP Ellipsis or Pseudogapping. An example of a distributional difference was illustrated in example (2), repeated here as (37).

(37) **Non-Coordinate Structures**

a. **VP Ellipsis – OK**

- i. Bruce back-checked quickly. Brenda did too.
- ii. Bruce back-checked quickly after Brenda did.

b. **Pseudogapping – OK**

- i. (First) Bruce stopped the right-wing player. (Then) Brenda did, the left-wing player.
- ii. Bruce stopped the right-wing player after Brenda did, the left-wing player.

c. **Gapping – Ungrammatical**

- i. *(First) Bruce stopped the right-wing player. (Then) Brenda, the left-wing player.
- ii. *Bruce stopped the right-wing player after Brenda, the left-wing player.

The notion that Gapping is a triggered operation may also be useful in accounting for differences in the availability of different deletion phenomenon cross-linguistically – for instance, the fact that Gapping can appear in languages (such as German and French) that do not allow VP Ellipsis or Pseudogapping (which are relatively rare, cross-linguistically). In viewing Gapping as a triggered operation, we expect that it must apply whenever its conditions of application are met. An investigation of the cross-linguistic consequences of the Gapping proposal discussed here is left for future research.

3.5 The Siegel Puzzle: Recap and Resolution

Let us reconsider to the Siegel Puzzle paradigm in light of what we have learned so far about Gapping.

- | | | |
|---------|---|---------------------------|
| (38) a. | John can't eat caviar and Mary eat beans. | WIDE-SCOPE MODAL ONLY |
| b. | John can't eat caviar and Mary can't eat beans. | DISTRIBUTED MODAL ONLY |
| c. | John can't eat caviar and Mary, beans. | WIDE-SCOPE OR DISTRIBUTED |

Assuming that the proposed Gapping generalizations are correct, (38a) and (38b) do not exhibit any Gapping. They are simply a small-conjunct (T-sharing) structure and a large-conjunct (C-sharing, or CP-level coordination) structure, respectively. We have seen one possible derivation for (38c), which accounts for its distributed modal reading. This derivation involves coordination below a shared C, which triggers deletion of the second modal, *can't*. The Chain of Deletion Generalization then leads us to expect deletion of the verb *eat*.

(39) **Distributed Modal Reading: C-Sharing and Gapping**

[_{CP} Ø [_{TP} John can't eat caviar] and [_{TP} Mary ~~can't eat~~ beans]].

One question remains: How is the gap produced in the Wide-Scope Modal reading of (38c)? If we abandon the assumption that Gapping requires a trigger, the example should be straightforward: since the Sharing Requirement for Gapping is met in the small-conjunct structure (38a), Gapping may take place, targeting V and deleting it to produce (38c). All of the examples in the paradigm are thus accounted for.

However, if we want to continue to assume that Gapping does require a trigger, then the fact that both instances of *eat* may be pronounced in (38a) indicates that the sharing configuration does not disrupt any particular relation between the shared T and the two Vs – that is, we can infer that no special relationship (captured either by features in the syntax or morphological properties in the post-syntactic component) needs to be established between T and

V in this example. If this is the case, the possibility for deletion revealed in (38c) will require us to draw one of two conclusions:

(40) Possible Conclusions to Draw

- a. there exist in the lexicon two types of auxiliaries/modals and two types of all verb stems, and these must be properly paired up in a given tree. One pair requires a relationship to be established between the auxiliary/modal in T and the verb in V. Placing these types of Ts and Vs in the sharing configuration results in Gapping (38c). The other pair does not require a relationship to be established. Placing these types of Ts and Vs in the sharing configuration will not trigger Gapping (38a);
- b. Gapping is not triggered in (38c). Therefore, *play* must be missing because some other deletion operation has taken effect.

I will not decide between these possibilities here. However, I will suggest a possible derivation based on the conclusion drawn in (40b). Specifically, we can analyze the wide-scope modal version of (38c) as the product of Pseudogapping – the details of which have been left vague, but of which we know at least the following: that the deletion operation employed in Pseudogapping takes place entirely within the VP shell, and that, if it has a trigger, the trigger is distinct from that of Gapping.

(41) Pseudogapping Analysis of (38c) (Wide-Scope Modal Reading)

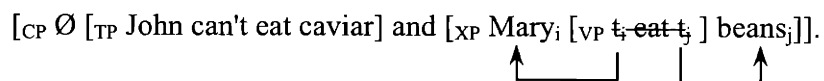

Under this analysis, (38c) simply represents a case of Pseudogapping, namely, Pseudogapping which has happened to apply within a sharing structure.^{28,29}

We have now accounted for all of the sentences in the Siegel Puzzle Paradigm, using a mix of Gapping and Pseudogapping analyses.

²⁸ It is interesting to note that the shared T in (41) appears able to license VP Ellipsis/Pseudogapping.

²⁹ Cf. the Pseudogapping-style analysis of Gapping proposed in Coppock 2001. She does not make an explicit connection to Pseudogapping, the Salvation By Deletion observation, or to Sharing, however.

3.6 Conclusion and Caveat

In this chapter, I have outlined the start of a new theory of Gapping. Gapping is hypothesized to be a PF deletion process which is crucially dependent upon a sharing configuration (the *Sharing Requirement on Gapping* hypothesis). The proposed theory of Gapping also encompasses two generalizations: the Highest Head Generalization and the Chain of Deletion Generalization. To the extent that these generalizations are able to correctly characterize the patterns of deletion and interpretation in Gapping constructions, this provides evidence in their favor.³⁰

Given the availability of large-conjunct structures (coordination above T), small-conjunct structures (coordination below T), Gapping, and Pseudogapping, a sentence which has traditionally just been called a Gapping sentence may actually be parsed in multiple ways. Consider, for example, the sentence in (42). Given the availability of C-sharing, T-sharing, and Pseudogapping, the sentence has (at least) five different possible parses:

(42) Joanne played the cello, and Jessica, the violin.

(43) **a. CP-Coordination + Pseudogapping**

[_{CP} ∅ [_{TP} Joanne played the cello]] and [_{CP} ∅ [_{TP} Jessica_j [_{VP} t_j [_{VP} ~~play~~ t_i] the violin_i]]].

b. C-Sharing + Pseudogapping

[_{CP} ∅ [_{TP} Joanne played the cello] and [_{TP} Jessica_j [_{VP} t_j [_{VP} ~~play~~ t_i] the violin_i]]].

c. C-Sharing + Gapping

[_{CP} ∅ [_{TP} Joanne played the cello] and [_{TP} Jessica ~~played~~ the violin]].

³⁰ Notably missing from our discussion of Gapping is the possibility of much larger Gaps:

(ia) Abigail believes that Patty prefers spearmint and Amber believes that Patty prefers peppermint.

(ib) Abigail believes that Patty prefers spearmint and Amber ~~believes~~ that Patty prefers peppermint.

(ic)(??) Abigail believes that Patty prefers spearmint and Amber ~~believes that Patty prefers~~ peppermint.

(iia) Cynara tried to score one goal and Esther tried to score two.

(iib) Cynara tried to score one goal and Esther ~~tried to score~~ two.

Related to the issue of how to produce larger Gaps is a question (raised by Kyle Johnson) regarding the interpretation of adverbs in Gapping contexts (namely, why some adverbs may not be interpreted as part of a Gap, while others must be). Unfortunately, I must leave to future research such questions related to patterns of deletion and interpretation involving larger Gaps.

d. T-Sharing + Pseudogapping

Joanne_i [[_{VP} t_i played the cello] and [_{VP} Jessica [_{VP} ~~play~~ t_j] the violin]_j].

e. T-Sharing + Gapping

Joanne_i [_{VP} t_i played the cello] and [_{VP} Jessica ~~play~~ the violin].

In the remaining chapters of this thesis, we will be focusing on the properties of a subset of possible Gapping structures, namely, small-conjunct structures that involve coordination below a shared T. Fortunately, it is possible to control for conjunct size. In order to ensure that the Gapping constructions under discussion involve coordination below T (43e), we must simply use sentences in which a main verb is pronounced in all conjuncts. By pronouncing the verb, we rule out the possibility of Pseudogapping (*(43a), *(43b), and *(43d)), since Pseudogapping (in English) necessarily involves removal of the verb at PF. Pronunciation of the main verbs also rules out a C-sharing structure (*(43c)). According to the Gapping generalizations we have established, the presence of a verb will indicate that the non-initial T can't be missing because it is being elided; rather, it must be the case that the T isn't pronounced because only one T exists in the structure – that is, it is being shared in a T-sharing structure.

The main lesson to take away from this chapter is: *conjunct size matters*. Remember this caveat and use it wisely in the following chapters.

4. The Interpretation of Shared Structures at LF: A-movement and the CSC*

In this chapter, we address one of the most obvious objections to the small-conjunct structures which we have been arguing for in Sharing and Gapping phenomena: that they sometimes require asymmetric movement out of a coordinate structure. In particular, we will examine the asymmetric A-movement proposed by Johnson (1996) to describe the movement undergone by the first subject in a T-sharing structure:¹

(1) a. Michelle scored one goal, and Marita, two goals.

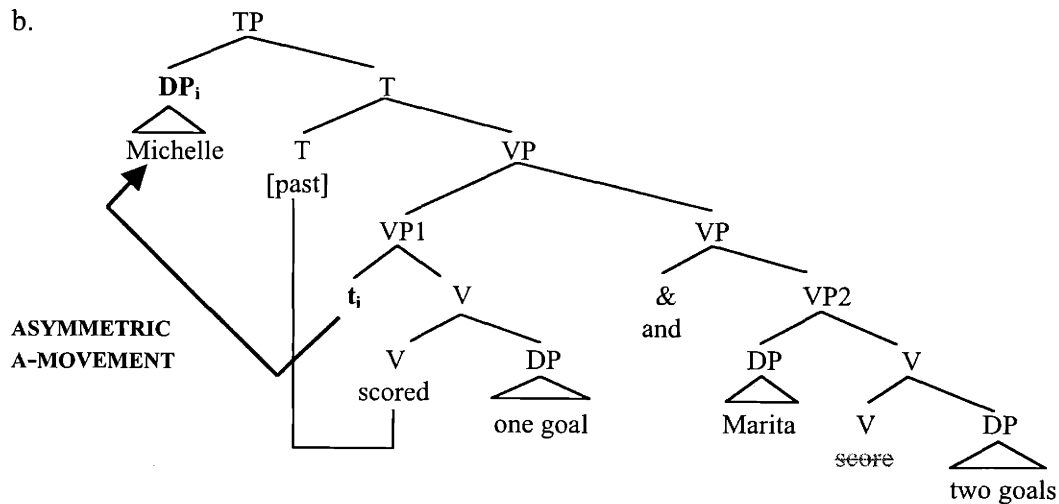

The asymmetric A-movement illustrated in (1b) appears to violate the Coordinate Structure Constraint (CSC), which, in its original formulation, states that extraction out of coordinate structures is not permitted, unless extraction takes place in an across-the-board (ATB) manner

* This chapter is a revised and extended version of Lin 2001.

¹ Another type of asymmetric extraction, involving asymmetric A'-movement to Spec-C, can be found in German and other related languages. While this phenomenon presents us with a set of interesting and potentially related puzzles, these lie outside the scope of the present work. (For examples and discussion, see Höhle 1990, Heycock and Kroch 1994, Kathol 1995, Schwarz 1998, and Johnson 2002, among others.)

out of all conjuncts (Ross 1967; Williams 1977, 1978).² Classic examples of the CSC effect and its ATB exception involve WH-movement:

- (2) a. * What_t does Bob speak t_i and Mary understand Taiwanese?
b. What_t does Bob speak t_i and Mary understand t_i?

Assuming that the sharing structure depicted in (1b) is correct (as argued for in Chapters 2 and 3), there are three logical conclusions one may draw given the paradox presented by: 1) the need for asymmetric A-movement out of the conjoined-VP structure (to satisfy the EPP feature of T), on the one hand, and 2) the ban on asymmetric extraction summarized in the CSC, on the other.³

(3) **Three Possible Conclusions**

- a. **Give Up Sharing Structure, Maintain CSC for A-movement**
The Small-Conjunct Approach must be incorrect; the CSC does apply to A-movement.
- b. **Maintain Sharing Structure, Give Up CSC for A-movement**
The Small-Conjunct Approach is viable; the CSC does NOT apply to A-movement.
(Johnson 1996)
- c. **Maintain Sharing Structure, Maintain CSC for A-movement**
The Small-Conjunct Approach is viable; the CSC does apply to A-movement.
(Lin 2001)

Given the range of evidence we have seen from Chapters 2 and 3 in favor of the existence of sharing structures, we will dismiss at the outset the conclusion drawn in (3a). This leaves us with the possible conclusions in (3b) and (3c). As discussed in Chapter 2, Section 2.2.2, Johnson (1996) argues for (3b): in favor of the Small-Conjunct Approach, and against the notion that A-movement is subject to the CSC. His evidence in favor of the sharing structure and asymmetric

² Ross's CSC also bans extraction of entire individual conjuncts; however, I do not explicitly deal with this part of the CSC.

³ Technically, there are four logical possibilities, the fourth being a rejection of both sharing structures and the CSC for A-movement. Although this is a possible conclusion to draw, it is not one that is motivated by the paradox at hand. Thus, I immediately dismiss this fourth possibility as a non-starter.

A-movement comes from the cross-conjunct binding sentences (Chapter 2, ex. 20, repeated here as (4), modulo the theory of Gapping proposed in Chapter 3).

- (4) a. Not every girl_i bought a hat and her_i brother a sweatshirt.

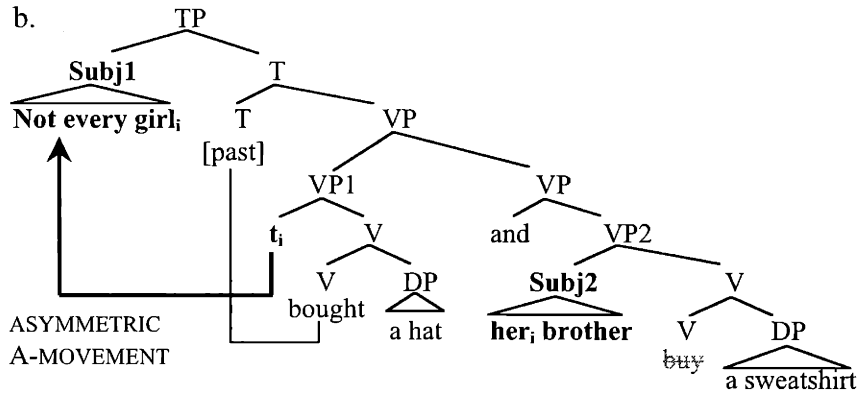

In (4), asymmetric A-movement is crucial for bringing the first subject, *not every girl*, into a position which is high enough to c-command the second subject, *her brother*. I take this as strong evidence in favor of the small-conjunct structure and the availability of asymmetric A-movement.

Regarding the issue of the CSC and whether it applies to A-movement, the route taken by Johnson (1996) is a reasonable one (see, for example, the discussion in Section 4.1); however, the evidence he uses to argue that A-movement is not subject to the CSC is not conclusive. In particular, his claim that ECM constructions allow us to see instances of objects undergoing asymmetric A-movement depends upon a particular parse of the coordinate structure involved in (5) (repeated from Chapter 2). Specifically, asymmetric A-movement will only take place if coordination is taking place at the XP-level in (5a).

- (5) a. Mary made Reggie_i out [_{XP} [_{XP} t_i to be intelligent] and [_{XP} Lukas to be kind]].

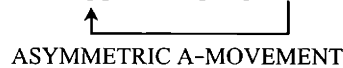

- b. [_{TP} Mary made Reggie_i out [t_i to be intelligent]] and [_{TP} ~~Mary made~~ Lukas_i out [t_i to be kind]].

However, as we learned in Chapter 3, and as Schwarz has noted (see Section 2.2.2), the size of the coordinated conjuncts cannot be assumed. In particular, there is no way to control for the underlying structure in (5b),⁴ which involves large-conjunct coordination (minimally at the TP-level), and therefore, no instances of asymmetric A-movement. The inconclusiveness of this argument, along with the conceptual arguments discussed in Section 2.2.2, lead me to question the conclusion stated in (3b).

Instead, I will argue in favor of the conclusion stated in (3c): that the Small-Conjunct Approach is viable (and in particular, that asymmetric A-movement does exist), and that the CSC does apply to A-movement. Chapters 2 and 3 already provide evidence in favor of the Small-Conjunct Approach. The work in this chapter lies in showing precisely how the CSC may be applied to A-movement. In order to show that A-movement does exhibit CSC effects, we will need to reevaluate the nature of the CSC, asking in particular where exactly in the grammar the CSC operates. We will see that treating the CSC as a constraint on representations, rather than a constraint on movement, makes interesting and correct predictions regarding the behavior of asymmetric A-movement.

We will approach the problem as follows. In Section 4.1, I place the question of whether or not A-movement obeys the CSC in a historical context. In Section 4.2, we consider data from Ruys 1992 involving covert movements out of coordinate structures. Ruys' data suggest that the CSC evaluates the structures which are the result of movement operations, rather than the movement operations themselves. The version of the CSC which we adopt will allow us to readdress in Section 4.3 the question of whether or not the CSC applies to A-movement; and we will see evidence which suggests that in fact it does. Section 4.4 provides further evidence in favor of the analysis offered in Section 4.3, and also suggests directions for future research. Section 4.5 concludes.

⁴ At least, there is no way that I am aware of at this time for controlling for the structure in (5b).

4.1 A-movement and the Coordinate Structure Constraint

Interestingly, despite the fact that the CSC (and its ATB exception) was originally formulated as a general constraint on movement out of coordinate structures (Ross 1968: 89), it is extremely difficult to find in the literature any independent evidence that A-movement is in fact subject to the CSC. That A-movement is subject to the CSC has been assumed, to advantageous effect. For example, in concurrent but independent papers, Burton & Grimshaw (1992) and McNally (1992)⁵ provide an argument in favor of the VP-internal Subject Hypothesis (e.g., Koopman and Sportiche 1985, 1991; Kitagawa 1986; Fukui and Speas 1986; Kuroda 1988) based upon A-movement in coordinate structures. In particular, they examine coordinated active and passive structures as in (6):

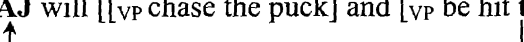
- (6) a. AJ will chase the puck and be hit from behind.
b. [TP **AJ** will [[VP chase the puck] and [VP be hit **t** from behind]]].
- 

Prior to the development of the VP-internal Subject Hypothesis, these types of coordinate structures posed a challenge to the CSC. Assuming that subjects of passive sentences are derived via a raising operation (i.e., A-movement from object position to surface subject position), and that subjects of active sentences are base-generated in Spec-T, the sentence in (6) should violate the CSC since only one conjunct has been extracted out of, yet the sentence is grammatical. Ross himself suggested on the basis of such sentences that A-movement may not be subject to the CSC: “It is obvious that there are many rules which do not necessarily apply across the board – passives can be conjoined with actives...” (Ross 1967: 98).

As noted, Burton & Grimshaw (1992) and McNally (1992) argue in favor of VP-internal subjects by assuming that A-movement is subject to the CSC. Under this assumption, the grammaticality of (6a) may be explained by the existence of a VP-internal subject in the active clause, *AJ will chase the puck*. Since the subject, *AJ*, is base-generated inside both the active and

⁵ McNally (1992) makes her assumption that the CSC applies to A-movement explicit in a footnote: “Although the CSC was not originally conceived of with NP-movement [A-movement] in mind, Williams’s (1978) reformulation of the CSC as across-the-board rule application is clearly intended to cover NP-movement in addition to *wh*-movement” (McNally 1992: 337, FN 3). I thank Alec Marantz for reminding me of this.

the passive VPs, it is able to undergo ATB movement to Spec-T, thereby avoiding a CSC violation (7).

- (7) [TP **A**_J will [[_{VP} **t** chase the puck] and [_{VP} **t** be hit **t** from behind]]].
-
- ↑
ATB A-MOVEMENT

The assumption that A-movement is subject to the CSC has thus proven theoretically useful; however, whether it is empirically justified still represents a gap in our understanding of the CSC.

In this chapter, we aim to fill in the gap by bringing to light a set of data which reveals that A-movement does exhibit CSC effects – although an appreciation of the facts will require a modification to Ross’s original version of the CSC.

4.2 The CSC as a Constraint on Representations

As long as the CSC is understood to be a constraint on movement, the grammaticality of sentences like (4a) would seem to force us to the conclusion that the CSC does not apply to A-movement out of coordinate structures. A number of researchers have provided arguments that the CSC should not be stated as a constraint on movement, however.⁶ In this chapter, we consider a subset of those arguments: data from Ruys 1992 which show that the CSC applies to the results of covert movement. Ruys’ argument is based on two parallels which he observes between overt WH-movement and both covert WH-movement and Quantifier Raising (QR). First, none of these movements may extract an element out of a conjunct, as illustrated in (8)–(10). (The examples in (8)–(13) are based on Ruys 1992: ex. 89–99; example (10) traces back to the work of Rodman 1976 and Lakoff 1986, however.)⁷

⁶ For summary and discussion, see Munn 1993, Chapter 3. On the related issue of when in a derivation the CSC should apply – e.g., at “Surface Structure” versus Logical Form (or even later) – see, for example, Rodman 1976, Goldsmith 1985, Lakoff 1986, Culicover and Jackendoff 1997, Postal 1998.

⁷ In constructing the examples involving WH-movement, I am grateful to David Pesetsky for pointing out to me the need for using a stative verb in the non-initial conjunct. This type of verb is needed in order to control for a

(8) **Overt WH-movement**

* **Which language_i** does Jeremy [_{VP1} know **t_i**] and [_{VP2} love Latin]?

(9) **Covert WH-movement**

a. * I wonder [_{CP} who_k t_k [reviewed **what**] and [knows the editor]].

b. LF: *I wonder [_{CP} who_k **what_i** t_k [reviewed **t_i**] and [knows the editor]]

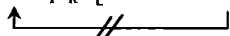

* WH-movement (violates CSC)

(10) **Covert QR**

a. Someone is [_{VP1} publishing every book] and [_{VP1} writing a check].

*every book >> a check; *every book >> someone

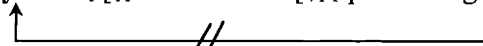
b. LF: **every book_i** [_{TP} Someone is [_{VP1} publishing t_i] and [_{VP2} writing a check]]

* QR (violates CSC)

(8) is a classic example of a CSC violation with overt WH-movement. The ungrammaticality of (9) can similarly be understood as a CSC violation: assuming that WH-in-situ must raise to an appropriate Spec-C at LF (following Huang 1982), the WH-in-situ *what* is moving out of the first conjunct only.⁸ In (10), the CSC does not produce ungrammaticality; rather, it rules out a particular interpretation by disallowing an instance of QR from taking place. First, (10a) lacks the inverse scope reading (object taking scope over the subject), in which people are varying with books. In addition, only one check is being written. This indicates that the universal quantifier *every book* is unable to move by QR out of its VP conjunct to take scope over the indefinite *a check* in the second conjunct. Ruys interprets the impossibility of QR out of the first conjunct as a CSC effect.

particular kind of *and* reading which is possible when the second verb is a non-stative, and which apparently allows asymmetric WH-extraction out of the coordination (in this case, the movement is of a relative WH-operator):

(i) Here's the whiskey which I went to the store and bought. (Ross 1967: 93, ex. 101a; Ross credits G. Lakoff with this generalization)

As stated in Chapter 2, FN 12, we will not be examining such cases of asymmetric WH-extraction.

⁸ In (9) (see also (12)), the subject *who* may have moved ATB out of two conjoined TP clauses. However, in the structures I am presenting, coordination is taking place below the surface subject position – thus, at an earlier point

The second parallel that Ruys observes between overt and covert movements pertains to the ATB exception to the CSC. Ruys shows that, like overt WH-movement, both covert WH-movement and QR may extract an element out of a conjunct as long as the extracted element is able to establish parallel relations with an element in each conjunct – traces in the case of overt WH-movement (classic ATB movement) (11), and traces and coindexed pronouns in the case of covert WH-movement (12) and QR (13).

(11) **Overt WH-movement**

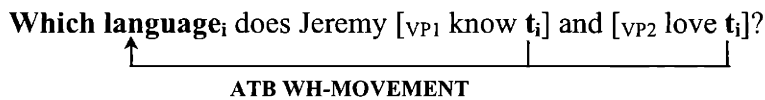

(12) **Covert WH-movement**

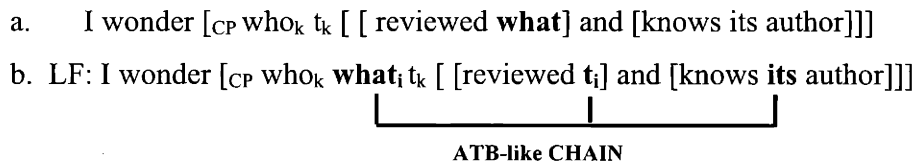

(13) **Covert QR**

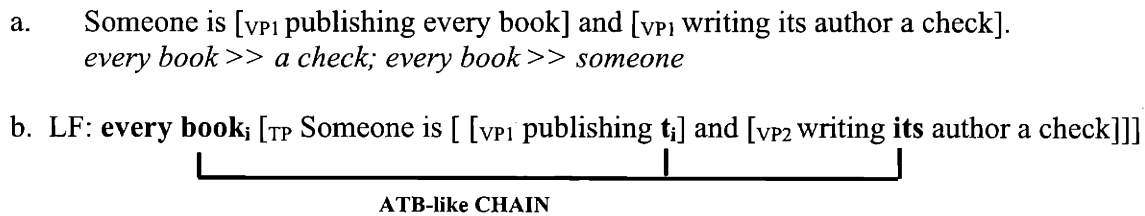

Ruys suggests that the pronouns *it* in (12) and *its* in (13) are interpreted as resumptive pronouns, which allows them to be “incorporated” into the ATB-like chains headed by *what* and *every book*, respectively (Ruys 1992: 37).

The grammaticality of (12) contrasts tellingly with the ungrammaticality of (9). While movement of the WH-in-situ *what* is apparently disallowed in (9), it must be allowed in (12), despite the fact that in both sentences, the extraction is taking place out of the first conjunct only. The grammaticality of (12) shows us that the extraction itself cannot be ruled out by the CSC.

in the derivation, *who* must have moved ATB out of its two VP-internal subject positions (not indicated in (9)). For the purposes of this paper, nothing hinges on the difference between these two derivations.

The same reasoning applies to the contrast between (10) and (13). While *every book* is unable to QR out of the coordination to take scope over *a check* in (10), the same QR is allowed in (13): note that (13) does have the reading in which checks vary with books (and authors).

As Ruys notes, if his interpretation of the covert movement facts is correct, then the CSC and the allowable exception to the CSC (“ATB movement”) are constraints not on movement, but on the representations (or chains) which result from movement operations (Ruys 1992: 38).⁹ If this is the case, we cannot use Ross’s version of the CSC, since it is stated over movement operations. Differences between the grammatical cases of asymmetric extraction ((11)–(13)) versus the ungrammatical cases of asymmetric extraction ((8)–(10)) suggest that the revised version of the constraint must be able to evaluate the relationship between the moved element and each of the conjuncts. In the tradition of multi-planar analyses of coordination (e.g. Goodall 1987, Muadz 1991, Moltmann 1992), CSC effects are proposed to be the result of evaluating grammatical constraints over precisely this sort of configuration.

In order to be concrete in the discussion that follows, I adopt the version of the CSC presented in Fox 2000.¹⁰ Following the tradition of multi-planar approaches, Fox (2000) suggests that there is no independent “Coordinate Structure Constraint.” Instead, there are only CSC effects, which he derives from the following two assumptions (Fox 2000: 50):

- (14) a. Extraction out of a coordinate structure is possible only when the structure consists of two [or more] independent substructures, each composed of one of the coordinates together with material above it up to the landing site (henceforth, *component structures*).
- b. Grammatical constraints are checked independently in each of the component structures.

⁹ David Pesetsky makes the intriguing suggestion that the CSC could still be maintained as a constraint on movement, if it could somehow “see” what is going on in the other conjunct (i.e., the one not being extracted out of) – in particular, whether or not there is a resumptive pronoun present. This would entail a broadening of our understanding of the class of ATB exceptions to the CSC.

¹⁰ It is important to make clear that Fox’s version of the CSC is not a crucial part of the analysis being presented in this chapter. I have adopted Fox’s version of the CSC in order to make the discussion explicit, and also because this type of approach to the CSC takes a step towards explaining CSC effects, rather than just describing them. However, if there is reason to reject this kind of approach to the CSC, we can do so without compromising the rest of the analysis.

The “grammatical constraints” which are checked in the component structures are understood to be independently attested elsewhere in the grammar (i.e., even outside the context of coordination). Thus, for example, the sentence in (8), repeated as (15), is ungrammatical because one of its component structures (15c) violates the constraint on vacuous quantification: the WH-operator in *which form* has nothing to bind.

(15) **Non-ATB WH-movement**

- a. * **Which language_i** does Jeremy [_{VP1} know **t_i**] and [_{VP2} love Latin]?

Component Structures:

- b. **Which language_i** does Jeremy [_{VP1} know **t_i**]
 c. * **Which language** does Jeremy [_{VP2} love Latin] * *due to constraint on vacuous quantification*

Contrast this with the ATB example in (11), repeated as (16):

(16) **ATB WH-movement**

- a. **Which language_i** does Jeremy [_{VP1} know **t_i**] and [_{VP2} love **t_i**]?

Component Structures:

- b. **Which language_i** does Jeremy [_{VP1} know **t_i**]
 c. **Which language_i** does Jeremy [_{VP2} love **t_i**]

Since both of its component structures are well-formed, (16) is grammatical.

Fox uses this particular view of the CSC in conjunction with his *Scope Economy* condition in order to explain the *Coordination Scope Generalization* (CSG). Scope Economy essentially states that a scope shifting operation (e.g., QR) may only apply if it affects semantic interpretation (Fox 2000: 21, 23, 26). The CSG states that “semantic effects of movement across coordination are invisible to Scope Economy” (Fox 2000: 49) – in other words, movement of a scope-bearing element α out of a conjunct will not satisfy Scope Economy if α only crosses coordination. In order for the scope-bearing element α to take scope over the coordination, there must be some scope-bearing element β higher than the coordination which α may move above in

order to affect semantic interpretation. (See Fox 2000 for details.) Evaluation of Scope Economy over component structures produces exactly this result. Since coordination (or disjunction) does not even appear in the component structures of a coordinate sentence,¹¹ movement of an element across coordination cannot be evaluated from the perspective of Scope Economy. In order for a scope-bearing element α embedded within a conjunct to take scope over the coordination, it must actually move to take scope over a scope-bearing element β within its component structure, and β must also happen to be above the point of coordination. If no scope-bearing element β exists higher in the tree, then movement of α above the point of coordination will not be licensed within the component structures.

With this new understanding of CSC effects, we can now readdress the question of whether or not A-movement obeys the CSC. Since the CSC is not a constraint on movement, A-movement itself will not be subject to the CSC. However, we can look to see whether or not A-movement exhibits CSC effects by examining the component structures which result from A-movement operations.

4.3 CSC effects and A-movement

Recall that we began asking whether A-movement obeys the CSC by looking to see whether A-movement out of coordinate structures can only take place in an ATB manner. In (1), repeated here as (17), we saw a grammatical case of asymmetric A-movement which suggests that A-movement out of a single conjunct must be a possible movement operation.

¹¹ This suggests that some other interpretive stage is required. What exactly is interpreted or evaluated at this other stage remains to be investigated; at the very least, it will include the truth conditions of the coordinate sentence (thanks to Satoshi Tomioka for drawing my attention to this). Fox alludes to this when he mentions semantic effects that movement within a component structure may have outside the component structure, including binding effects and scope relative to coordination (Fox 2000: 62).

(17) a. Michelle scored one goal, and Marita, two goals.

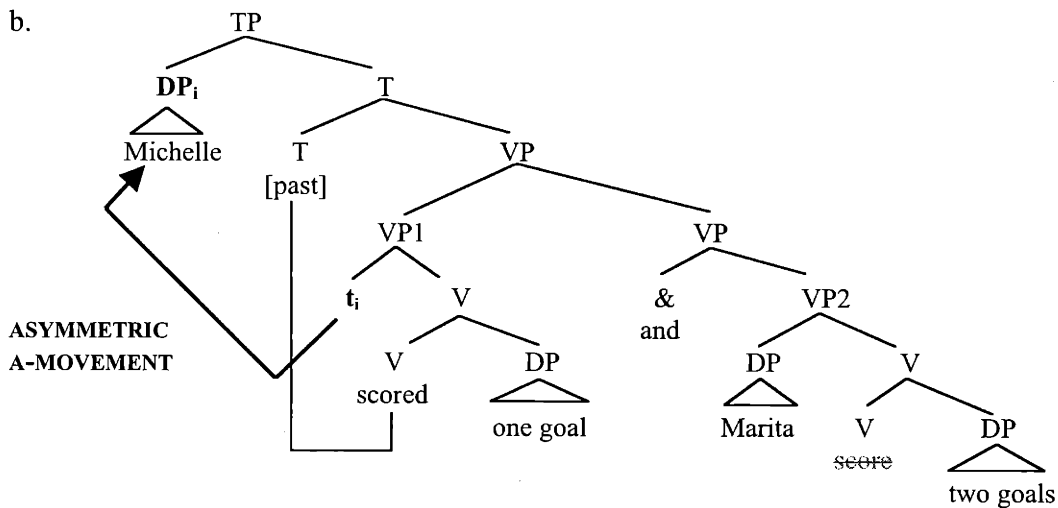

This conclusion is not surprising if the CSC is not a constraint on movement. Given the view of the CSC presented in Section 4.2, it is still relevant to ask whether A-movement exhibits CSC effects. In particular, we can look to see how evaluation of component structures affects where an A-moved element may or may not be interpreted. In Section 4.3.1, I spell out the specific prediction made by the CSC for A-movement, and I present evidence that the prediction is correct in Section 4.3.2. In Section 4.3.3, I examine an apparent exception to the prediction, and show that it in fact fits into a general pattern of CSC effects. In Section 4.3.4, I discuss some puzzles noted by Johnson (1996) for his small-conjuncts and asymmetric A-movement analysis; in light of our newly revised notion of the CSC and how it affects A-movement, we will see that these puzzles are no longer a mystery.

4.3.1 What the CSC Predicts

As we have seen in examples like (17), sentences that involve VP-level coordination (with distinct subjects in each conjunct) contain instances of asymmetric A-movement. Consider now the sentence in (18), which preserves the crucial ingredient of VP-level coordination while stripping away obscuring details such as gapping and binding. (Pronunciation of a verb in each conjunct ensures VP-level coordination under the shared modal *will*, as discussed in Chapter 3.)

(18) [_{TP} **Desmond**_i will [_{VP1} **t**_i sing the vocal part], and [_{VP2} Molly play the bass part]].



ASYMMETRIC A-MOVEMENT

The first subject, *Desmond*, undergoes asymmetric A-movement to satisfy the EPP feature of the single T-node. How will the resulting component structures be evaluated?

First, consider the case in which *Desmond* does not reconstruct. The component structures will be as in (19):

(19) **Component Structures: No A-reconstruction**

- a. **Desmond**_i will **t**_i sing the vocal part
- b. ***Desmond** will Molly play the bass part **due to Theta Criterion (e.g.)*

While (19a) appears to be fine, (19b) is ill-formed with respect to the Theta Criterion. Although both *Desmond* and *Molly* occupy argument positions, one of the two (presumably *Desmond*) will fail to receive a theta role, since the structure only allows for a single external argument.¹²

Now consider the case in which *Desmond* does reconstruct.¹³ The component structures will be as in (20):

(20) **Component Structures: A-reconstruction**

- a. will [_{VP1} Desmond sing the vocal part]
- b. will [_{VP2} Molly play the bass part]

Intuitively speaking, there is nothing wrong with either of the component structures in (20). For example, neither component structure violates the ban on vacuous quantification or the Theta Criterion.

¹² Alternatively, or perhaps additionally, *Molly* in (19b) will not receive case assignment, assuming that *Desmond* has been assigned nominative case.

¹³ I am using “reconstruct” as a descriptive term, to mean simply that an element is being interpreted in a position lower in the tree than its surface position. For now, I have nothing to add to the debate regarding the mechanism for such interpretation, e.g., lowering versus the copy theory of movement. However, I am assuming that an element can only be interpreted lower in the tree (than its surface position) if it appeared lower in the tree at some earlier point in the derivation.

If this application of the CSC¹⁴ is correct, then we predict that the CSC will require reconstruction of the subject *Desmond* in (18), since without reconstruction, one of the component structures will be ill-formed. I will refer to this kind of necessary reconstruction as the *CSC effect on A-movement*. Of course, in this particular example, it is impossible to see whether or not such reconstruction is taking place. In order to reveal the reconstruction, we will place scope-bearing elements in the first subject, and see how these are interpreted with respect to sentential negation.

4.3.2 Evidence of Reconstruction: A Missing Reading

Imagine the following scenario: we are in charge of a music camp, and we have to worry about how many different types of musicians we will have in the camp at any one time. This entails knowing about when different groups of musicians will leave and arrive. Now consider the following:

(21) Many drummers can't leave on Friday.

This sentence is ambiguous. The subject *many drummers* may take scope over negation, giving us a reading which can be paraphrased as: *for many different individual drummers, it's the case that they are unable to leave on Friday* (due to personal scheduling difficulties, e.g.). The subject may also be interpreted below negation; this gives us a meaning roughly paraphrased as: *it is not allowed that a large group of drummers leave on Friday* (otherwise, we'll have too many guitarists and not enough drummers to go around, e.g.). If we place this sentence in a small-conjunct structure with asymmetric A-movement, our revised notion of the CSC predicts that *many drummers* must reconstruct – i.e., must be interpreted in a position below negation. The prediction is borne out in (22):

(22) Many drummers can't leave on Friday, and many guitarists arrive on Saturday.

¹⁴ As a reminder, “CSC” is now being used as shorthand for a component structures-based analysis of CSC effects.

The first subject of this sentence, *many drummers*, can only be interpreted as taking scope below negation: *it can't be the case that many drummers leave on Friday and many guitarists arrive on Saturday* (because this will lead to an imbalance in the different types of musicians we have on hand). The CSC effect on A-movement correctly predicts that *many drummers* must reconstruct in (22).

In the next subsection, we turn to cases where the CSC effect on A-movement apparently does not hold.

4.3.3 An Exception to the CSC Effect on A-movement

Recall that in cross-conjunct binding sentences, the first subject must be moving to a higher position in order to c-command (and therefore bind) a variable in the second subject. However, we have just seen that the CSC forces A-movement reconstruction in exactly these types of coordinate structures.

(23) a. Not every girl_i will buy a hat and her_i brother buy a sweatshirt.

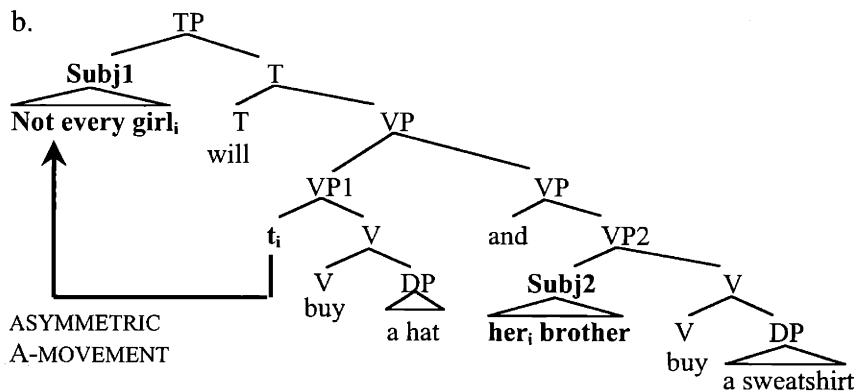

How can the two needs – upstairs interpretation for binding, downstairs interpretation for satisfaction of the CSC – be reconciled?

Under this approach, there is no such thing as an independent Coordinate Structure Constraint.

Since (23) is grammatical with the indicated binding relation, it must be the case that *not every girl* is able to remain high in the tree – that is, *not every girl* apparently does not need to reconstruct. Let us look at the component structures to see why.

(24) **Component Structures**

- a. **Not every girl_i** will [_{VP1} **t_i** buy a hat]
- b. **Not every girl_j** will [_{VP1} **her_j** brother buy a sweatshirt]

The component structure in (24a) is the same structure we would get for the non-coordinate sentence, *Not every girl ate a green banana*. Thus, I assume it is fine and set it aside. Turning to the second component structure, if we follow Ruys's lead and interpret *her* as a kind of resumptive pronoun, incorporating it into the chain headed by (*not*) *every girl*, then (24b) parallels the LF representation for the non-coordinate sentence in (25), on the inverse scope reading:

- (25) a. A different girl admires every boy's mother. *every*>>*a*
- b. LF: **every boy_i** [_{TP} a (different) girl admires [_{VP} **t_i**'s mother]]

In effect, the relationship between (*not*) *every girl* and *her* – an operator binding a variable – licenses the appearance of *not every girl* in (24b).

In fact, the sentence in (23) is simply another instance from Ruys's paradigm of covert exceptions to the CSC, discussed in Section 4.2. We can see the parallel more clearly if we spell out the component structures of (12) and (13), repeated here as (26) and (28):

(26) **Covert WH-movement**

- a. I wonder [_{CP} who_k t_k [reviewed **what**] and [knows its author]].
- b. LF: I wonder [_{CP} who_k **what_i** t_k [[reviewed t_i] and [knows its author]]]

(27) **Component Structures**

- a. I wonder [_{CP} who_k **what_i** [_{TP} t_k [reviewed t_i]]]
- b. I wonder [_{CP} who_k **what_i** [_{TP} t_k [knows its_i author]]]

(28) **Covert QR**

- a. Someone is [_{VP1} publishing every book] and [_{VP1} writing its author a check].
every book >> a check; every book >> someone
- b. LF: **every book**_i [_{TP} Someone is [_{VP1} publishing **t**_i] and [_{VP2} writing **its** author a check]]

(29) **Component Structures**

- a. **every book**_i [_{TP} someone is [_{VP1} publishing **t**_j]]
- b. **every book**_j [_{TP} someone is [_{VP2} writing **its**_j author a check]]
- 

Although the precise nature of the “resumptive pronoun” in (24b), (27b), and (29b) is not well understood at this time, a pattern clearly exists: the resumptive pronoun licenses the appearance of an operator which has moved out of the first conjunct in a position above the coordination.¹⁵

4.3.4 Johnsons's (1996) Puzzles

In the previous two subsections, we have seen evidence for the CSC effect on A-movement – necessary A-reconstruction – as well as an ATB-like exception to the CSC effect. This new understanding of the CSC as it applies to A-movement may help us to solve some problems originally noted by Johnson (1996) for his proposed structures involving small-conjuncts and asymmetric A-movement. Johnson's puzzles stem from a particular interpretation of the structures involving asymmetric A-movement – one which does not take into account effects of the CSC. Johnson interprets the possibility of asymmetric A-movement out of coordinated VPs as a prediction that the moved subject should (always) take scope above elements in the conjuncts. The cross-conjunct binding sentences appear to bear this prediction out. But Johnson points out that the prediction seems to fall through with other diagnostics for scope: NPI licensing (30b, c), and disjoint reference effects (31)¹⁶

¹⁵ As with questions regarding the nature of the resumptive pronoun, I also set aside for now questions regarding constraints on the relative positioning of the operator versus the resumptive pronoun – that is, the fact that the operator must apparently originate in the first conjunct.

¹⁶ Johnson also discusses sentences with reciprocal binding that similarly appear to contradict the predictions he makes regarding subject scope:

- (30) a. *No one likes green bananas and anyone, ripe ones.
b. *Few people ate everything and some people, anything. (Johnson 1996: 35, ex. 94)

- (31) Nishi_i likes fashion mags and Nishi_i's/the model_i's friends, political rags.
(Johnson 1996: 35, FN 28)

We should first note a potential confound in the examples in (30). As pointed out by Linebarger (1980), coordination of two NPI-containing conjuncts with *and* appears to block NPI licensing by a higher negation:

- (32)* I didn't buy any apples and any bagels. (Linebarger 1980: 37, ex. 57)

In contrast, *or* allows NPI licensing:

- (33) I didn't buy any apples or any bagels. (Linebarger 1980: 37, ex. 56)

We should therefore replace *and* with *or* in (30a) and (30b). The results are still unacceptable, however:

- (34) a. *No one likes green bananas or anyone, ripe ones.
b. *Few people ate everything or some people, anything. (Johnson 1996: 35, ex. 94)

The judgment can be sharpened by constructing a minimal pair, one with cross-conjunct binding, and one without. The prediction is that NPI licensing (of an NPI in the second conjunct by

-
- (i) *The girls bought bowling balls and each other's parents, bags. (Johnson 1996: 35, ex. 94a)

This sentence also appears to contradict the predictions I would make in the context of the CSC effect on A-movement. In particular, the fact that a binding relation could be established between the antecedent *the girls* and the reciprocal *each other's* should be enough to allow the first subject to avoid the CSC effect (see Heim, Lasnik, and May 1991 on the relationship between reciprocals and their antecedents). In order to account for the ungrammaticality of (i), Johnson appeals to a locality condition on the distance between the reciprocal and its antecedent. He argues that this is what produces the ungrammaticality of (ii):

- (ii) ?*The girls_i denied that Betsy's photos had arrived and each other_i's pictures had been purchased.
(Johnson 1996: 36, ex. 95)

negation in the first subject) will be possible in the cross-conjunct binding case, but not otherwise, since the CSC will require reconstruction of the first subject.

- (35) a. No girl will eat a green banana, or any of her friends drink a pureed one.
b. *No girl will eat a green banana, or any boy drink a pureed one.

As (35) shows, the CSC effect makes the correct prediction regarding the possibility of NPI licensing by negation in the first subject.

Let us turn to the case of disjoint reference ((31), repeated as (36)). Johnson's example poses a problem for him because he incorrectly predicts a Condition C violation. The first subject should c-command the referential expression (*Nishi* or *the model*) in the second subject, thus triggering the requirement for disjoint reference. However, the sentence is unexpectedly grammatical.

- (36) *Nishi_i likes fashion mags and Nishi_i's/the model_i's friends, political rags.*
(Johnson 1996: 35, FN 28)

Again, the CSC effect makes the correct prediction in this case: the first subject, *Nishi*, must reconstruct, thereby removing it from the c-commanding position which would trigger the Condition C effect.^{17,18}

The puzzles posed by Johnson are thus not so puzzling after all. The data show us that the first subject is sometimes interpreted above the coordination (e.g., cross-conjunct binding sentences), and sometimes inside it (e.g., the cases of failed NPI licensing and the missing

I will follow Johnson's lead for this example. (Danny Fox points out, however, that it may be possible to construct an alternative account if we accept Heim, Lasnik, and May's (1991) proposal that the *each* part of the reciprocal *each other's* must move to adjoin to the antecedent (*the girls* in this example).)

¹⁷ Danny Fox notes that the Condition C effect cannot be tested for in this structure using a pronoun in the first subject, due to an independent constraint which blocks pronouns from preceding their antecedents in conjoined structures: e.g., *I like her_i brother and you like Tara_i. Coreference is not possible, despite the fact that no c-command relation holds between *her* and *Tara*.

¹⁸ There is an interesting interaction between the CSC effect and Fox's (2000) notion of *Scope Economy*, which predicts that names will not reconstruct (since no scopal relations would be affected by their doing so). The evidence we have seen so far regarding the CSC effect on A-movement suggests that the CSC may obviate Scope Economy in this case. The interaction between these types of constraints on interpretation represent a fruitful area for future research; for now, I take only a brief look at this issue in Section 4.4. (Thanks to Danny Fox for discussion of this topic.)

Condition C effect). The CSC effect and its ATB exception correctly tell us in each case where the subject may be interpreted.

4.4 The CSC Effect and Other Constraints on Interpretation

I turn now to the interaction between the CSC effect on A-movement and other constraints on interpretation. This section marks just the start of a line of research into such constraint interaction; at this stage, much of the work that needs to be done is empirical in nature. For example, the constraints themselves need to be identified and made explicit. Furthermore, a body of data needs to be amassed, showing the outcome of different constraint conflicts. Sections 4.4.1 and 4.4.3 represent the kind of empirical work I am describing. In Section 4.4.1, we will see two cases in which the CSC effect is able to override a ban on A-reconstruction. In Section 4.4.2, we will take what we learned in Section 4.4.1 and show that is consistent with what we have established so far regarding the CSC effect on A-movement and its ATB exception. In Section 4.4.3, I examine the interaction of forced A-reconstruction with the observation that A-moved negative quantifiers cannot reconstruct (von Stechow and Iatridou 2001, attributed to Lasnik 1999).

4.4.1 The CSC Effect versus a Ban on Reconstruction

In this section, we will examine two more pieces of evidence in favor of the CSC effect on A-reconstruction. They follow the same pattern: in a small-conjunct structure, an asymmetrically A-moved first subject (containing disjunction in one case and *a single NP* in the other) must be interpreted as taking scope under sentential negation. This fact is particularly interesting because, for some ill-understood reason, these particular types of subjects are unable to take scope under sentential negation outside the context of the coordinate-VP structure. Consider the non-coordinate sentence in (37), in which the disjoined subject takes scope in its surface position above negation:

(37) **Bob or Mary_i** can't [_{VP} **t_i** eat rice].

The disjoined subject *Bob or Mary* cannot receive a neg-over-*or* interpretation – that is, (37) states either that Bob can't eat rice or that Mary can't eat rice. In contrast, when disjunction appears under the scope negation, the neg-over-*or* reading becomes available (see the discussion in Chapter 2). We can see this in (38) by giving negation surface scope over a disjoined object.

(38) Jeremy can't eat **rice or beans**.

On the neg-over-*or* reading, (38) states that Jeremy can't eat rice and that Jeremy can't eat beans. The lack of the neg-over-*or* reading in (37) indicates that the disjunction is unable to be interpreted below negation – in other words, that the disjoined subject cannot reconstruct.

A similar phenomenon can be illustrated using *a single NP* as subject:

(39) **A single student_i** did not [_{VP} **t_i** ride the elevator].

In (39), where *a single student* appears above negation on the surface, it is only possible to interpret *a single student* as a specific indefinite. Crucially, *a single student* is not interpreted as taking scope under negation; (39) cannot mean that no student rode the elevator. This contrasts with (40), where *a single elevator* takes surface scope under negation, to produce what I refer to as the NPI reading of *a single NP*.

(40) Mary did not ride **a single elevator**.

We can paraphrase (40) as: *Mary did not ride any elevators* (or *Mary rode no elevators*). The lack of the NPI reading in (39) indicates that the subject *a single student* is unable to be interpreted under negation – again indicating an inability to reconstruct.

The reconstruction possibilities for these subjects change, however, when we place them in coordinate structures with asymmetric A-movement. Recall that the version of the CSC which

we have adopted predicts that reconstruction of the A-moved subject is necessary in this particular structure. The interpretation of the sentences in (41) seems to bear this prediction out:

- (41) a. [TP **Bob or Mary**_i can't [[VP₁ t_i eat rice], and [VP₂ Jeremy eat potatoes]]].
 b. ? [TP **A single student**_i did not [[VP₁ t_i ride the elevator], or [VP₂ a single professor climb the stairs]]].

The disjunction in (41a) receives a neg-over-or reading which may be paraphrased as: *It can't be the case that Bob eats rice while Jeremy eats potatoes AND it can't be the case that Mary eats rice while Jeremy eats potatoes.*¹⁹ In (41b), *a single student* has only the NPI reading: (41b) states that no students rode the elevator (and that no professors climbed the stairs). Since these readings are only possible if the scopal elements in the subjects (i.e., disjunction or *a single*) are interpreted under the scope of negation, I interpret the readings as evidence that the subjects in (41a) and (41b) are reconstructing below negation.

The sentences in (41) show us that A-movement is subject to CSC effects. Evaluation of component structures requires the first subject to be reconstructed back to its base position. Moreover, the examples from this subsection show us that the CSC can force reconstruction of subjects which are normally unable to reconstruct below negation.²⁰

4.4.2 The CSC Effect versus Cross-Conjunct Binding: The Case of a single NP

In Section 4.3.3, we examined the potential conflict between the CSC effect and the c-command relation which is required for cross-conjunct binding ((23) repeated as (42)):

- (42) Not every girl_i will buy a hat and her_i brother buy a sweatshirt.

¹⁹ Contrast (41a) with (i), which lacks the coordinate structure:

(i) Bob or Mary can't eat rice while Jeremy eats potatoes.

Just as in (37), the disjoint subject is unable to reconstruct below negation. Thus, (i) only has a wide-scope *or* reading: Either Bob can't eat rice while Jeremy eats potatoes, or Mary can't eat rice while Jeremy eats potatoes.

²⁰ Cf. the discussion of the CSC effect versus Scope Economy in FN 18.

A look at the component structures for (42) showed us how the presence of *her* in the second VP obviated the CSC effect, allowing *every girl* to remain in a position high enough to c-command the variable *her*. We can combine this with what we learned about *a single NP* in Section 4.4.1: as the subject of a non-coordinate sentence involving sentential negation, *a single NP* is unable to reconstruct below negation, but as the subject which has been independently A-moved out of the first conjunct of a coordinate-VP structure, *a single NP* can (and in fact must) reconstruct below sentential negation, producing an NPI reading. If we induce a binding relation between the first and second subjects, we predict that the NPI reading will be lost, since *a single NP* cannot reconstruct below negation if it is to remain high enough to bind a variable in the second subject. The contrast between (43a) and (43b) bears this prediction out. (The judgements indicated in (43) are for the NPI reading of *a single defendant*.)

- (43) a. ?[_{TP} **A single defendant_i** did not [[_{VP1} **t_i** question the verdict], or [_{VP2} a single attorney file an appeal]].
- b. #[_{TP} **A single defendant_i** did not [[_{VP1} **t_i** question the verdict], or [_{VP2} his_i attorney file an appeal]].

In (43a), the CSC effect results in reconstruction of *a single defendant* below negation; the sentence tells us that no defendants questioned the verdict (and that no attorneys filed any appeals). In (43b), in contrast, *a single defendant* must not undergo reconstruction if it is to remain in a position c-commanding *his* in the second VP. As predicted, *a single defendant* does not have an NPI reading in this sentence; (43b) does not say that no defendants questioned the verdict. Rather, (43b) tells us that exactly one defendant–attorney pair did not have any complaints about the outcome of their trial (thus, no questions or appeals on their part).²¹

The differences in interpretation between (43a) and (43b) lend further support to the proposed analysis of the CSC effect.

²¹ Note that there is nothing in principle which blocks *a single defendant* from binding a variable while under the scope of negation. Compare (43b) to (i):

(i) I didn't see a single defendant_i or his_i attorney at the courthouse on Sunday.

(I am assuming a structure for coordination/disjunction in which the first conjunct takes scope over the second conjunct.)

4.4.3 The CSC Effect and the Epistemic Containment Principle

In Section 4.4.1, we saw that the CSC effect is able to force A-reconstruction of subjects containing disjunction or *a single NP*, as indicated by their scope relative to sentential negation. This reconstruction is particularly interesting in light of the fact that these subjects are unable to reconstruct below negation outside the context of coordinate-VP structures. The potential conflict between the two competing constraints on interpretation – the CSC effect on the one hand and the ban on reconstruction below negation on the other²² – is resolved in favor of the CSC effect.

In this subsection, I consider a similar potential conflict. The source of the conflict stems from the observation that negative quantifiers do not undergo A-reconstruction (von Fintel and Iatridou 2001, attributed to Lasnik 1999),²³ as illustrated in (44):

(44) No one is certain to solve the problem. (Lasnik 1999: ex. 65)

As Lasnik notes, (44) lacks the reading which can be paraphrased as *It is certain that no one will solve the problem*; *no one* apparently cannot reconstruct below the modal *is certain*. Von Fintel and Iatridou (2001) use the generalization that negative quantifiers cannot undergo A-reconstruction in conjunction with their *Epistemic Containment Principle* to explain the oddness of sentences like (45):

(45) *Nobody may have pushed him. (Maybe he just fell.) (von Fintel & Iatridou 2001, ex. 43)

(The judgment reported in (45) depends upon neutral intonation; i.e., *nobody* should not be receiving any sort of stress.) Von Fintel and Iatridou's Epistemic Containment Principle is an LF

²² I have only presented evidence that subjects containing disjunction or *a single NP* cannot reconstruct when sentential negation is present. However, it may be that these particular subjects are simply banned from A-reconstruction altogether (in non-coordinate-VP structures), irrespective of whether or not sentential negation is present. Either way, the conflict between the CSC effect and the ban on A-reconstruction (for these subjects) stands.

²³ Lasnik (1999) does not actually present this generalization as such; rather, the generalization represents von Fintel and Iatridou's interpretation of a subset of Lasnik's data, which actually includes a broader range of quantified subjects that are unable to undergo A-reconstruction. Following von Fintel and Iatridou 2001, and contra Lasnik 1999, I assume that A-reconstruction exists in principle, but that it may be restricted by as-yet ill-understood constraints. (See Bobaljik and Wurmbrand 1999 for arguments that A-movement may reconstruct.)

constraint which bans quantifiers from taking scope over epistemic modals. In (45), the Epistemic Containment Principle requires *nobody* to be interpreted in its reconstructed position below the epistemic modal *may*. However, this requirement conflicts with the generalization that negative quantifiers cannot undergo A-reconstruction. Von Stechow and Iatridou suggest that the conflict between these two requirements cannot be resolved, leaving (45) with “no grammatical construal” (von Stechow & Iatridou 2001: 15).

The Epistemic Containment Principle cannot override the constraint on negative quantifier A-reconstruction, and at the same time, the constraint on negative quantifier A-reconstruction cannot override the Epistemic Containment Principle. But what will happen if we combine the negative-quantifier subject and the epistemic modal with a coordinate-VP structure? The CSC effect will come into conflict with the ban on negative quantifier A-reconstruction. Based on the pattern of data discussed in Section 4.4.1 (cf. also FN 18), we might expect that the CSC effect will similarly prevail in this case. (Note that this is not a prediction, but an empirical question: What will the outcome be in the case of conflict between the CSC effect and the ban on negative quantifier reconstruction?) Consider the contrast in (46):

- (46) a. * No student may have picked Mary.
b. No student may have picked Mary, and no professor, chosen Bob.²⁴

The grammaticality of (46b) shows us that the CSC effect is able to override the constraint on negative quantifier A-reconstruction. Interestingly, the CSC effect is able to force reconstruction in a case where the Epistemic Containment Principle fails to do so (46a).

We have now seen at least two examples ((i) the case of *or* and *a single NP*, and (ii) the case of negative quantifiers) in which the CSC effect is able to "override" other constraints on interpretation: in both cases, the CSC is able to force reconstruction where other constraints are working to block reconstruction.²⁵ It would be wrong to conclude that the CSC effect is always able to force reconstruction, however. Some subjects resist even the CSC effect. Bare subject NPIs provide an obvious example:

²⁴ (46b) may require coordination of constituents which are slightly larger than VPs. Crucially, however, coordination is taking place below the single, shared modal *must*.

²⁵ See also FN 18.

- (47) a. *Any student didn't pick Mary.
b. *Any student didn't pick Mary, or any professor, choose Bob.

As the ungrammaticality of (47b) shows, the CSC effect is unable to force reconstruction of the NPI *any student* below negation.

Many questions are raised by this subsection – including why certain subjects but not others may undergo A-reconstruction, and how conflicts between different interpretive constraints are resolved. These questions point to an intriguing direction for future research, one which I will unfortunately be unable to pursue any further here.

4.5 Conclusion

This chapter began as a response to an objection to Johnson's (1996) Small-Conjunct Approach to Gapping, namely, that the asymmetric A-movement required of the first subject seems to violate the Coordinate Structure Constraint. Because I adopt small-conjunct structures and asymmetric A-movement in my own analysis of Gapping and other coordination phenomena, this objection to Johnson 1996 is an objection I needed to address as well. I have done so in this chapter in a somewhat roundabout way: I have argued against the objection by claiming that A-movement itself is simply not subject to the CSC, since the CSC does not actually exist as a constraint on movement operations. I presented an argument suggesting that the CSC holds over representations, rather than movement operations, and considered an approach to the interpretation of coordinate structures (i.e., evaluation of component structures) which would allow us to derive CSC effects. Given our revised understanding of what the CSC is, I then provided evidence that A-movement – or more specifically, the result of A-movement and A-movement reconstruction – is in fact subject to CSC effects (i.e., forced A-reconstruction), as well as ATB-like exceptions to CSC effects.

The response to the objection not only allows us to maintain the Small-Conjunct Approach to coordination phenomena, it also sheds light on the nature of the Coordinate Structure Constraint and opens up new avenues for future research.

5. More Sharing and Gapping: Determiner Sharing*

In the previous chapters, we have seen arguments for, and applications of, the Small-Conjunct Approach to certain coordination phenomena. One of the salient features of this approach is the structural feature which we have been referring to as *sharing*: shared structure sits above the coordination, and elements in this part of the structure may be shared among the conjuncts (e.g., a shared element may establish an independent relationship with an element in each conjunct). In this chapter, we will consider yet another kind of Gapping phenomenon and show how the sharing approach may be fruitfully applied to its analysis.

McCawley (1993) first described the Gapping phenomenon we will consider. He noted that a determiner which appears overtly with an initial-conjunct NP may be "shared" (McCawley uses this term descriptively) with corresponding determinerless NPs in subsequent conjuncts (1). This kind of *determiner sharing* is possible only if Gapping has taken place (2):^{1,2}

- (1) a. Too many Irish setters are named Kelly, ~~too many~~ German shepherds ~~are named~~ Fritz, and ~~too many~~ Huskies ~~are named~~ Nanook. (William Safire column, 12/22/85)
- b. The temple of Dagon, for example, whose exterior is seen in act one and ~~whose~~ interior ~~is seen~~ in act three, rivals a movie set.
(Chicago Reader opera review, 11/10/89)
- c. The duck is dry and ~~the~~ mussels ~~are~~ tough, but Bocuse D'Or rehearsal goes well for chef Bumbaris. (Chicago Tribune food section caption, 1/17/91)
- d. My needs are modest, [and] ~~my~~ annoying habits ~~are~~ few.
(Peter Svenonius, housing request posted at MIT, 8/23/99)
- (2) a. * Too many Irish setters are named Kelly, ~~too many~~ German shepherds are named Fritz, and ~~too many~~ Huskies are named Nanook.

* This chapter draws upon Lin 1999 and Lin 2000.

¹ Examples (1a)–(1c) are cited from McCawley 1993. Elements which have been struck-through are not pronounced, but should be interpreted as if they were present.

² McCawley's observation was that determiner sharing depends upon Gapping, where "Gapping" is used in the traditional sense to refer to sentences which are missing finite verbs. In Section 5.1, I show that this observation needs to be refined.

- b. * The temple of Dagon, for example, whose exterior is seen in act one and whose interior is seen in act three, rivals a movie set.
- c. * The duck is dry and the mussels are tough, but Bocuse D'Or rehearsal goes well for chef Bumbaris.
- d. * My needs are modest, [and] my annoying habits are few.

Without gapping, the determinerless NPs in (2) can only be interpreted as bare plural NPs.³

In addition to his observation regarding the dependency of determiner sharing upon Gapping, McCawley noted a number of other generalizations, among them the following:

(3) McCawley's Determiner Sharing Generalizations

a. The shared determiner must be initial in all conjuncts.

- i. How many cathedrals are there in Hartford or – opera houses – in Detroit?
- ii. * In Hartford, how many cathedrals are there, or/and in Detroit, – opera houses –?
- iii. Too many films are reviewed by Ebert and – concerts – by von Rhein.
- iv. * Ebert reviews too many films and von Rhein – – concerts.

(McCawley 1993: 247, ex. 6)

b. With shared determiners, Gapping may be licensed in some structures where Gapping would otherwise be ungrammatical.

- i. * The temple of Dagon, whose exterior is seen in act one and whose interior – in act three...
- ii. The temple of Dagon, for example, whose exterior is seen in act one and whose interior ~~is seen~~ in act three, rivals a movie set. (McCawley 1993: 246, ex. 11)

c. Not all determiners may be shared.

- i. * A soup was too salty and – pie – too sweet, but otherwise the food was outstanding.
- ii. * An Irish Setter should be called Kelly and – German shepherd – Fritz.

(McCawley 1993: 245, ex. 5)

The goal of this chapter is to present an analysis of the determiner-sharing phenomenon which accounts for the dependency of determiner sharing upon Gapping (2), the distribution of determiner sharing environments (3a), and the puzzle posed by cases in which Gapping appears

³ I use the "*" symbol to indicate sentences which lack the intended determiner-sharing reading; the sentences themselves may actually be grammatical.

to depend upon determiner sharing (3b). While a complete analysis of determiner sharing should be able to make the proper distinction between those determiners which can share, and those which cannot, I do not address this issue in this thesis, concentrating instead on providing an account for determiners which can be shared.⁴

In Section 5.1, I show that the determiner-sharing phenomenon patterns with other types of sentences we have seen so far: wide-scope modal sentences, wide-scope negation sentences, and cross-conjunct binding sentences, which all exhibit necessary T-sharing (see Chapter 2). This natural grouping suggests that the determiner sharing sentences, like the other necessary T-sharing sentences, depend in some way upon small-conjunct structures. A small-conjunct analysis will explain the Gapping (or rather, T-sharing) feature of determiner-sharing sentences, but the question remains: how is the dependency of determiner sharing upon T-sharing to be explained? And how is the determiner Gap produced?

In Section 5.2, I summarize two previous approaches to determiner sharing: Johnson's (2000) small-conjunct analysis of shared negative determiners, and my own small-conjunct analysis of determiner sharing (Lin 2000) which relied on a particular theory of the syntax of DPs, Sportiche's (1997) DP-Partitioning Hypothesis. After noting some of the problems faced by each of these approaches, I propose in Section 5.3 a new analysis of the determiner sharing phenomenon, one which builds upon Johnson 2000. In Section 5.4, I show how the proposed analysis of determiner sharing may be applied to the case of determiner sharing in conjoined relative clauses. I conclude in Section 5.5 with a summary and remarks on remaining issues.

5.1 Determiner Sharing and Necessary T-sharing

In Chapter 2, we discussed three types of conjoined sentences which require T-sharing: wide-scope modal sentences, wide-scope negation sentences, and cross-conjunct binding sentences. The analyses offered for these three types of sentences shared one notable feature:

⁴ Although McCawley does not provide an exhaustive list of the determiners which may undergo determiner sharing, the shared determiners in the examples from his paper include: the definite determiner *the*; possessives like *your*; degree phrases like *too many* and *how many*; the possessive relative *whose*; and the NPI *any*. The term "determiner" in "determiner sharing" is thus being used as a loose cover term to refer to a non-homogenous group of things which may be shared.

they all relied on a particular structural configuration, namely, a small-conjunct structure involving coordination below T. It is precisely this sort of structure which allows a left-peripheral element – a modal, negation, or a variable binder – to sit above the conjunction and thus take scope over elements in the conjuncts; the result is the property which we have called necessary T-sharing (Chapter 3). The structural approach taken by our analysis explains the lack of T in non-initial conjuncts as a by-product of the height of conjunction or disjunction, rather than the result of any derivational mechanism (such as movement or ellipsis).⁵ Necessary T-sharing may thus be used as a diagnostic for the height of coordination. If a particular construction exhibits necessary T-sharing, we can infer that the sentence involves coordination below T (or lower).

Given this diagnostic for the height of coordination, let us take a closer look at the relationship between determiner sharing and Gapping. As we have seen, one of the peculiar aspects of determiner sharing is its dependence on Gapping.

(4) Necessary Gapping

- a. The girls drink whiskey and -- boys -- wine.
- b. * The girls drink whiskey and -- boys drink wine.

In fact, this Gapping requirement needs to be refined. As I show in the paradigm in (5), whether or not the verb has gapped actually makes no difference for determiner sharing. Determiner sharing is dependent upon *tense* being absent from non-initial conjuncts.⁶

(5) Necessary T-sharing

- a. The girls will drink whiskey, and – boys, drink wine.
- b. * The girls will drink whiskey, and – boys will drink wine.
- c. * The girls will drink whiskey, and – boys will – wine.

As long as T is missing, the verbs may even differ:

⁵ Note that I am only referring to T; in a T-sharing structure, other mechanisms (such as deletion/ellipsis) may still apply to other elements, such as non-initial verbs (see Chapter 3).

(6) **Necessary T-sharing Above Differing Verbs**

- a. The boys will wash the dishes, and – girls, mop the floor.
- b. * The boys will wash the dishes, and – girls will mop the floor.

Identifying the exact nature of the Gapping requirement – that determiner sharing depends upon T being missing – thus enables us to group the determiner-sharing phenomenon with other sentences that also exhibit this property. This natural grouping allows us to infer that, as in the case of other necessary T-sharing sentences, coordination must be taking place below T in determiner-sharing sentences. This predicts that determiner sharing will be compatible with the other T-sharing phenomena, in particular, with wide-scope modals, wide-scope negation, and cross-conjunct binding.⁷

(7) **Wide-Scope Modal and Determiner Sharing**

- a. The girls can't eat caviar, and – boys – eat beans.
- b. 'It can't be the case that the girls eat caviar and the boys eat beans'.

(8) **Wide-Scope Negation and Determiner Sharing**

- a. The boys can't play chess, or – girls – play checkers.
- b. 'The boys can't play chess and the girls can't play checkers'.

(9) **Cross-Conjunct Binding and Determiner Sharing**⁸

Not every girl_i will vote yes and – friend of hers_j vote no.

As (7) – (9) show, determiner sharing is indeed grammatical in wide-scope modal, wide-scope negation, and cross-conjunct binding sentences.

⁶ David Pesetsky (p.c.) points out that (5a), like some other determiner-sharing sentences, sounds much better when embedded within an *if*-clause: *If the girls will drink whiskey, and boys, drink wine, then...(all hell will break loose).*

⁷ Judgments for the cross-conjunct binding plus determiner sharing example may not be entirely consistent. Many people find determiner sharing bad (or at least more difficult) when the NPs involved are singular. However, examples (i) and (ii) are reported to be grammatical in Johnson 2000 (ex. 18), and (iii) is cited from a Chicago Sun-Times interview with Rajiv Gandhi (May 4, 1988) in McCawley 1993 (ex. 1):

- (i) Each student brought beer and each faculty member ~~brought~~ scotch.
- (ii) No representative voted for the proposition or ~~no~~ senator ~~voted~~ against it.
- (iii) Your daughter is 16 and ~~your~~ son is 17-1/2.

⁸ This example stems from a suggestion made to me by Danny Fox.

Note that in these three examples, we have included the verb in the non-initial conjuncts. As explained in Chapter 3, pronunciation of the verb controls for a T-sharing structure. Thus, in the case of (7), for example, only the wide-scope modal interpretation is available, and this is independent of the determiner sharing. Recall now that if both T and the verb are missing, such sentences are potentially ambiguous, since they may be derived via Gapping from either a large-conjunct or a small-conjunct structure, as in the case of the Siegel example discussed in Chapter 3 (repeated here as (10)):

- (10) a. John can't eat caviar and Mary, beans.
- b. **Wide-Scope Modal (Small-Conjunct Structure)**
John can't eat caviar and Mary eat beans.
- c. **Distributed Modal (Large-Conjunct Structure)**
John can't eat caviar and Mary ~~can't eat~~ beans.

Given that determiner sharing depends upon the T-sharing structure, we predict that determiner sharing in sentences which are missing both T and V (and are therefore potentially ambiguous) will disambiguate in favor of the wide-scope modal reading. Example (11) bears this prediction out.^{9,10}

(11) **Determiner Sharing and Wide-Scope Modal Interpretation**

- a. The girls can't eat caviar, and – boys – beans.
- b. 'It can't be the case that the girls eat caviar and the boys eat beans'.

This supports the claim that determiner-sharing sentences involve coordination of small constituents below T.

⁹ Only wide-scope/distributed modal sentences may be used to test the prediction that determiner sharing will disambiguate sentences with T-V Gaps in favor of the T-sharing structure. Wide-scope negation sentences cannot be used due to the possible existence of an independent means of giving *or* wide scope (e.g., syntactic movement or semantic wide scope). And cross-conjunct binding sentences cannot be used since the binding phenomenon itself requires a T-sharing structure.

¹⁰ Ackema and Szendrői (to appear) discuss this prediction and note a potential counter-example:

(i) In general, too many girls can't eat caviar and – boys – beans. (Ackema and Szendrői, to appear: ex. 21)
They claim that (i) has a distributed scope reading (and perhaps even favors it over a wide-scope modal reading). I do not yet have an explanation for this example.

5.2. Previous Small-Conjunct Approaches to Determiner Sharing

In Section 5.1, I identified determiner-sharing sentences as belonging to a group of constructions which exhibit necessary T-sharing. This property allows us to infer that coordination must be taking place below T in determiner-sharing sentences, and suggests that the analysis of determiner sharing will require a Small-Conjunct Approach.

In this section, I will summarize two previous Small-Conjunct approaches to determiner sharing, those of Johnson 2000 (Section 5.2.1) and Lin 2000 (Section 5.2.2). In Section 5.2.3, I briefly discuss some of the shortcomings of each of these approaches.

5.2.1 Johnson's (2000) Analysis of Determiner Sharing

Johnson's (2000) analysis of determiner sharing is based upon the approach to Gapping laid out in Johnson 1996. As discussed in Chapter 2, Johnson (1996) proposes that simple verb Gapping is the product of small-conjunct, VP-level coordination plus overt ATB movement of the verbs to the single, shared T sitting higher in the tree. In order to account for the surface positions of subjects in Gapped sentences, Johnson assumes that subjects originate in VP-internal positions and suggests that the first subject undergoes asymmetric A-movement to Spec-T, while the second subject remains in situ.

Under Johnson's approach to Gapping, some of the elements which appear on the surface to be sitting in a leftmost conjunct are actually outside (and above) all of the conjuncts. There are three possible sources for the surface positions of these elements. First, an element may have been moved out of a single conjunct. This would describe the case for Subject 1 in the schema given in (12) (asymmetric A-movement). Second, an element outside the conjuncts may have been placed there via overt ATB movement, as happens in the case of the verb in (12). Third, an element may have been base generated outside of the conjuncts. This would be the case for negation in (12).

(12)

(based on Johnson 1999: 60, ex. 5)

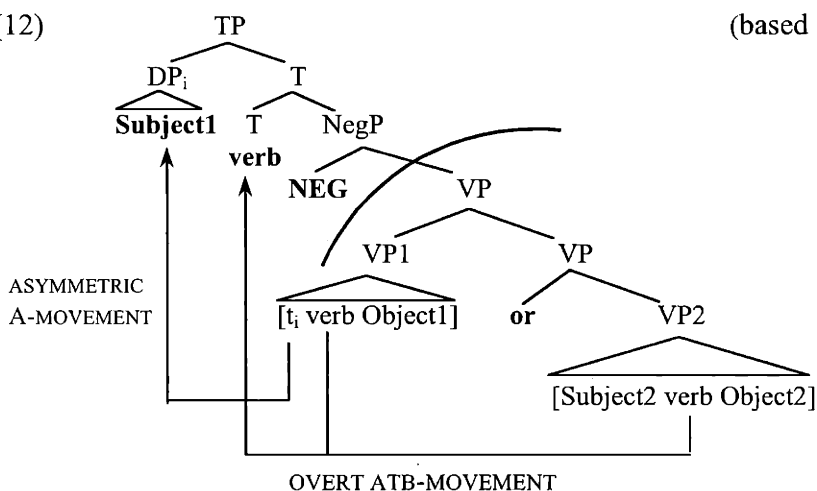

The surface effect of the last two of these options is what is perceived as a Gap, and it is on the last option – base generation of an element above the conjuncts – that Johnson models his analysis of determiner sharing (for negative determiners). In particular, Johnson draws a parallel between determiner sharing and the behavior of the adverb *rarely* in (13).

(13) A German shepherd is rarely named Kelly or an Irish setter – Fritz.

- (14) a. A German shepherd is rarely named Kelly or an Irish setter is rarely named Fritz.
b. A German shepherd is rarely named Kelly and an Irish setter is rarely named Fritz.
(Johnson 2000: 60, ex. 4)

In (13), *rarely* behaves in a way similar to wide-scope negation. It does not distribute into the disjuncts; (13) cannot be paraphrased as in (14a). Instead, *rarely* seems to have scope over both disjuncts, leading to a neg-over-or type of reading, paraphrased with *and* in (14b). Johnson interprets this fact as indicating that *rarely* must be base generated above the coordination in this example.

In order to explain the relationship between *rarely* and the two indefinite subjects (which are assumed to contain variables), Johnson (2000) analyzes the quantificational adverb *rarely* as an unselective binder which binds into the VPs below it (following Kamp 1981, Heim 1982).

The first subject is hypothesized to reconstruct into its base position within VP1 so that its variable may be bound by the adverb, as illustrated in (15).^{11,12}

(15) (Johnson 2000: 64. ex. 11)

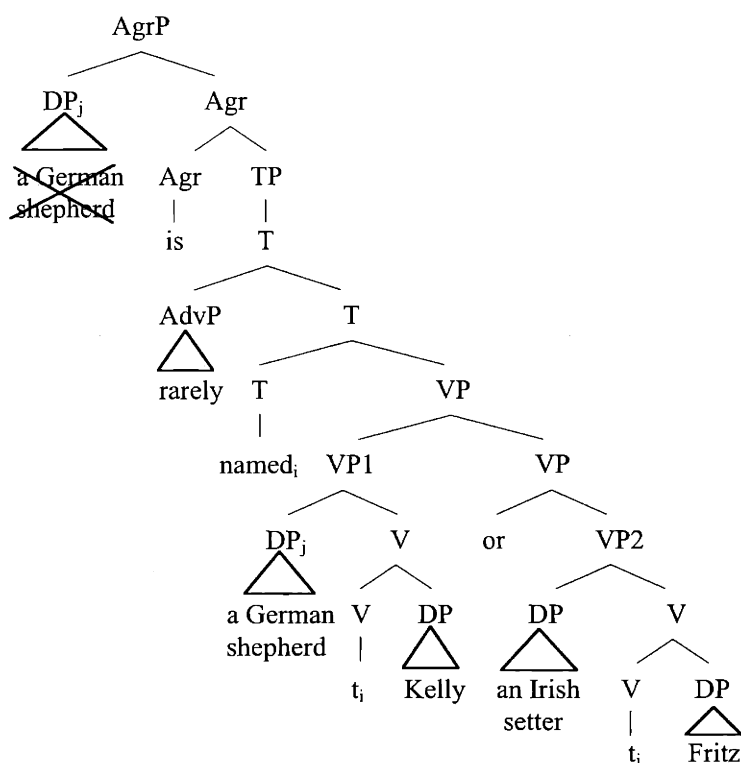

Since both the first and the second subjects are under the scope of *rarely*, *rarely* is able to unselectively bind the variable in each of the indefinite DPs, *a German shepherd* and *an Irish setter*.

For the determiner-sharing phenomenon to fit into Johnson's schema for Gapping, the shared determiner – or some part of it – must sit outside of the conjuncts. In order to locate that part of determiners which can be shared, Johnson (2000) focuses on *few* and *no*, hypothesizing that these determiners may be decomposed into a negative part and an indefinite part. (See also Kratzer 1995, Christensen 1986, and Kayne 1998, cited in Johnson 2000). Johnson proposes to treat the negative part (similar to *not*) as an adverb generated in a position separate from its

¹¹ Given our examination of the CSC effect on A-movement in Chapter 4, this reconstruction is actually predicted to be necessary within the given small-conjunct structure.

related DP, and the indefinite part (e.g., “many” and “any,” for *few* and *no*, respectively) as a phonologically null determiner which forms a constituent with its NP complement. In English, these phonologically null determiners, φ “many” and ψ “any,” must always appear in a structure with the negative adverb. In order to enforce the dependency of the null determiners on the negative adverbs, Johnson classes the null determiners as negative polarity items, subject to a licensing requirement (16a). Furthermore, since the negative adverbs are always pronounced together with the null determiners on the surface (producing *few* and *no*), Johnson adopts the constraint in (16b) to ensure that these two pieces are put together in the syntax.

- (16) a. [A phonologically null indefinite (φ , ψ)] must be within the c-command domain of [a negative adverb] at LF.
 b. [The negative adverbs *few* and *no*] must be adjoined to a DP headed by φ [or ψ] by Spell-Out. (Johnson 2000: 73, ex. 25)

Johnson suggests that determiner sharing of *few* and *no* is the result of base-generating the negative part of these determiners in an adverbial position above the conjunction. This negative part may license the NPI null determiners in the conjuncts below. Since the negative adverb need only be adjoined to a single DP, the first suitable DP (i.e., one which is headed by φ or ψ) raises to the adverb, and the combination gives us the overt determiner *few* or *no* at Spell-Out.¹³ The other (non-raised) DP remains headed by a phonologically null indefinite, and is therefore not pronounced with any overt determiner. Thus, for example, the sentence in (17) would have the structure given in (18).

- (17) Few dogs eat Whiskers or – cats – Alpo. (Johnson 2000: 68, ex. 18)

¹² In the trees that follow, I generally simplify Johnson's (2000) representations, leaving out in particular X'-notation, except where employing it aids the presentation. Nothing hinges on this choice.

¹³ It is always the DP headed by φ or ψ in the first conjunct which raises to the negative adverb. This fits in with the pattern of asymmetric movement we have seen so far (e.g., asymmetric A-movement of the first subject, versus non-initial subjects), a pattern which has been left unexplained in this thesis.

(18)

(Johnson 2000: 74, ex. 27)

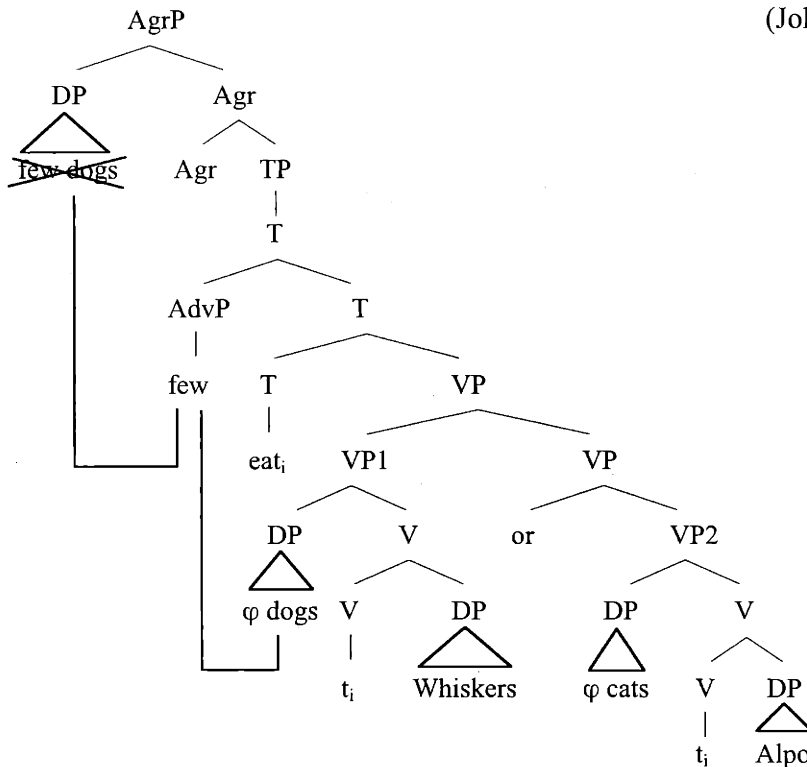

The verbs *eat* undergo ATB movement to T. The DP constituent φ *dogs* moves to the AdvP headed by *few*, creating a new DP constituent *few dogs*, as well as satisfying the constraint on *few* imposed by (16b). The new DP then moves to its final position in Spec-Agr (surface subject position, for Johnson). In order for the constraint in (16a) to be met, the overt movements undergone by the DP (φ *dogs*) and the adverb must be reconstructed to their base positions at LF. (Johnson assumes that *few* cannot c-command φ *cats* from its DP-adjoined position within *few dogs*.) As Johnson notes, reconstruction provides us with the correct reading for (17), paraphrased as (19), where *few* is interpreted as *not plus many*:

(19) It's not the case that many dogs eat Whiskers or that many cats eat Alpo.

(Johnson 2000: 75, ex. 29b)

In the case of shared determiners on object DPs, Johnson argues that the negative adverb *few* may appear in a lower position in the tree (specifically in a V'-adjoined position), drawing a parallel to the possible VP-internal appearance of the adverb *rarely*:

(20) We give books about syntax rarely to our parents.

(Johnson 2000: 77, ex. 35)

Coordination must take place below the negative adverb in order for determiner sharing to take place. For example, the sentence in (21) would have the structure in (22):

(21) I'll give few Brussels sprouts to Mary or – lima beans to Max. (Johnson 2000: 77, ex. 34b)

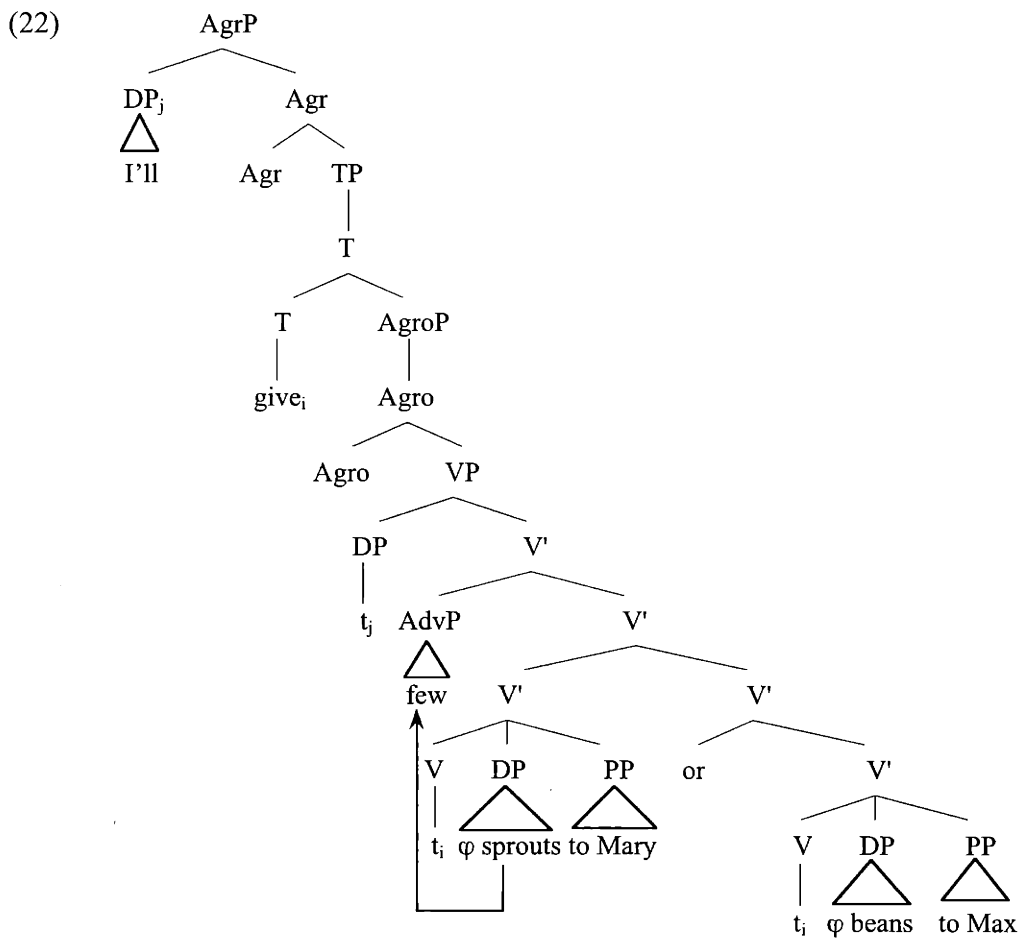

The single subject *I* has undergone movement to Spec-Agr. The verbs *give* have undergone overt ATB movement to T. As indicated by the arrow, the first object DP, *φ sprouts*, moves to the AdvP, creating a new DP constituent *few sprouts*. (Johnson assumes that the new DP, *few sprouts*, eventually undergoes overt movement into Spec-Agro for Accusative case marking.)

For Johnson, then, determiner sharing (of negative determiners) is the result of the sharing of a single, c-commanding licenser by two phonologically null heads.

5.2.2 Lin's (2000) Analysis of Determiner Sharing

In Lin (2000) (see also Lin 1999), I suggested that Sportiche's (1997) DP-Partitioning Hypothesis, in combination with small-conjunct structures, allows us to provide a simple structural account for the determiner sharing data. Sportiche's DP-Partitioning Hypothesis postulates that determiners and quantifiers always begin in a derivation "partitioned off" from their complement noun phrases. On this view, a verbal predicate takes an NP as its complement, not a DP. According to Sportiche, everything "non-thematic" associated with an NP argument will be generated outside the "thematic complex," the verbal projection containing a predicate and its NP complement. This includes referential and quantificational properties, as well as plural number specification. Thus, what surface as names, pronouns, and quantifiers, for example, are all associated with D heads sitting outside and above the thematic complex.¹⁴ The basic proposal is summarized in (23) and schematized in (24).

(23) Sportiche's DP-Partitioning Hypothesis

Determiners and their NP complements do not begin as constituents in syntactic derivations.

¹⁴ I use "D head" as a loose cover-term to refer to a variety of different positions along a particular stretch of the syntactic tree, above the thematic complex and below T. It is possible that different non-thematic information may be generated at different functional heads in this area of the tree. Furthermore, many of the "D" elements which I discuss are phrasal elements, and not just heads.

(24)

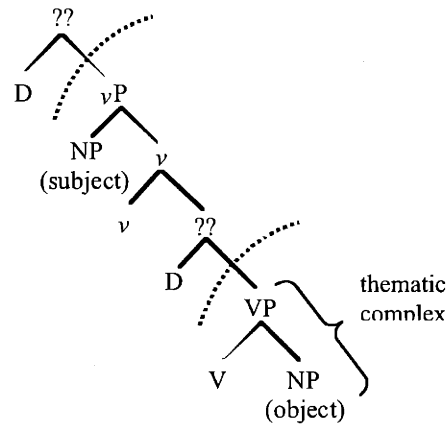

Because Sportiche does not discuss in any detail the specific mechanics required by his hypothesis, I made the following proposals in Lin 2000: that “D” requires an overt NP complement; that the movement of an NP to its D is driven by uninterpretable features on D (agreeing with the relevant ϕ features on the NP); and that the newly created DP constituent may undergo further raising to higher positions in the tree.

Although Sportiche's DP-Partitioning Hypothesis raises many questions (including questions regarding the exact nature of the movement of NPs to Ds and the identity of the constituent(s) labeled with question marks in (24)), I argued in Lin 2000 that if we set these worries aside, the DP-Partitioning Hypothesis together with the Small-Conjunct Approach would allow us to provide a very simple account of the McCawley facts by giving us constituents below D which can be coordinated. Specifically, I proposed that determiner sharing is the result of coordination immediately below a shared D-head. In order to locate the D head in the syntactic tree, I referred to the dependency of (subject) determiner sharing upon T-sharing (repeated here from (6)):

(25) **Necessary T-sharing**

- a. The boys will wash the dishes, and – girls, mop the floor.
- b. *The boys will wash the dishes, and – girls will mop the floor.

As a reminder, we inferred from the T-sharing requirement that determiner-sharing sentences must involve coordination below T. If determiner sharing requires T-sharing, then the shared D head must be located below T.

For subject determiner-sharing sentences, I proposed the following structure:

(26)

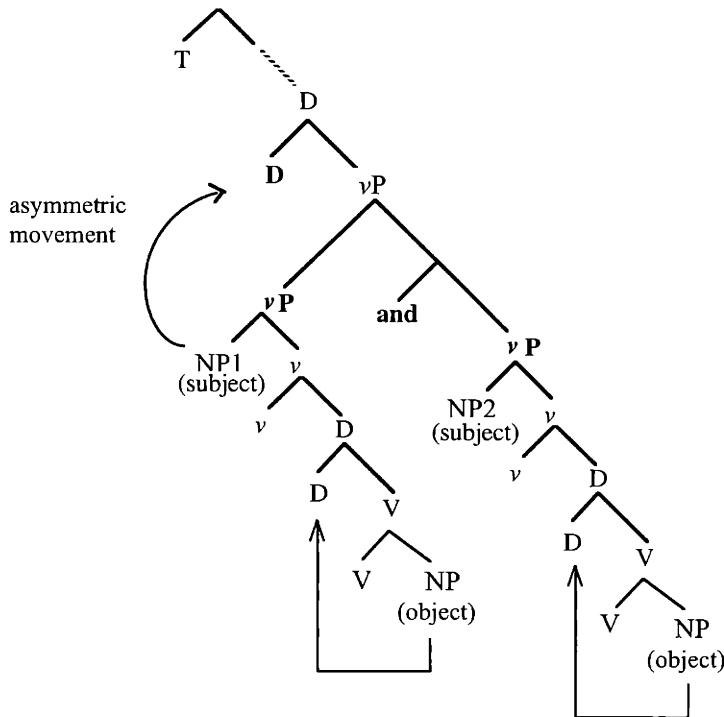

In order to check its uninterpretable features, the single subject-related D in (26) agrees with and attracts the first NP, which raises asymmetrically out of the coordinate vP structure. The second subject NP remains in situ. (Determiner sharing itself was suggested to be a semantic phenomenon, in which the “sharing” of the single subject determiner by the two subject NPs takes place only at LF; I return to this point in Section 5.2.3.)

The structure in (26) allows us to capture two basic facts about subject determiner-sharing sentences: 1) necessary T-sharing, and 2) McCawley’s observation that shared determiners must be initial in their conjuncts. First, since D is (by hypothesis) below T in the syntactic tree, coordination below D will entail coordination below T, resulting in necessary T-sharing. Note

that this explains why determiner sharing is not possible in Pseudogapping sentences ((5c), repeated as (27)):

(27)* The girls will drink whiskey, and – boys will – wine.

Since the second conjunct in the Pseudogapping example has a T node, coordination must be taking place above D, thus precluding the possibility of determiner sharing.

Second, since determiner sharing depends upon coordinating immediately below the shared D, the shared D will always appear to be initial in its conjunct(s). In order for a determiner to be non-initial in a conjunct, coordination must be taking place above it; and coordination above D will result in the presence of two separate Ds, one in each conjunct, thus blocking determiner sharing. For example, in (28), object determiner sharing is not possible since coordination is taking place above the object-related D head. (The second conjunct must be large enough to host a subject, which sits above the object-related D head.)

(28)* Bob should phone the boys, and Mary e-mail – girls.

Given the right structure, object determiner sharing can be grammatical (29). The analysis of object determiner sharing in Lin 2000 followed that of subject determiner sharing, the only difference being that the point of coordination was lower in the syntactic tree (30):

(29) Mary will eat the tofu on Monday and – pizza on Tuesday.

(30)

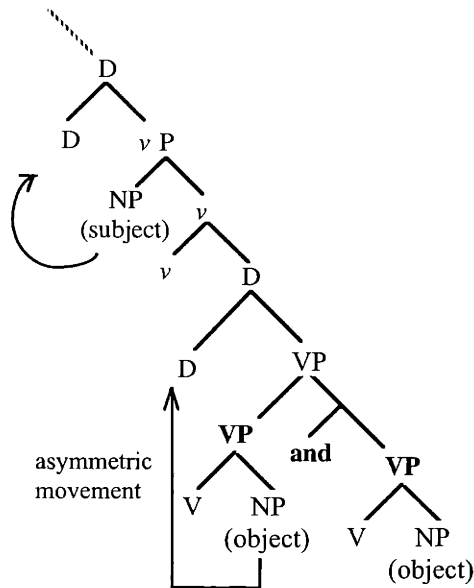

The first object NP raises up to the object-related D to check its uninterpretable features, and the second object NP remains in situ.

As in the case of subject determiner sharing, this structure allows for a simple explanation of necessary T-sharing (31a) and the conjunct-initial placement of determiners in object determiner sharing sentences (31b).

- (31) a. *Mary will drink the soup and will eat – hotdog.
b. *Mary will [[_{VP} give pizza to the girls] and [_{VP} feed tofu to – boys]].

First, coordination below the object-related D entails coordination below T, resulting in necessary T-sharing. Second, object determiner sharing is only possible if coordination takes place immediately below an object-related D, thus preventing anything from appearing before the shared D within any of the conjuncts. The structure in (30) also allows us to capture an additional restriction on object determiner sharing sentences, namely, the requirement that non-initial subjects must also be missing: since the object-related D is (by hypothesis) generated below the thematic complex containing *v*, the head introducing the external argument, there can be only one subject in an object determiner sharing sentence.

- (32) a. * Mary will eat the tofu, and **Bob** – eat – hotdog.
b. * Mary will eat the tofu, and **Bob** – – hotdog.

In fact, as long as everything above the shared object determiner is missing from non-initial conjuncts, object determiner sharing should be acceptable.

- (33) a. Mary gave [[the girls pizza] and [– boys tofu]].
b. Mary gave [[the pizza to Jessica] and [– tofu to Joanne]].

As illustrated in the double object construction (33a) and the prepositional dative construction (33b), the proposed analysis makes the right predictions.

5.2.3 Some Drawbacks of Johnson 2000 and Lin 2000

Both Johnson 2000 and Lin 2000 are able to capture the dependency relation between determiner sharing and Gapping, as well as a number of the distributional characteristics of determiner sharing noted by McCawley (e.g., the requirement that the NP which is sharing a determiner be initial in its conjunct). However, each of them suffers from at least one drawback which is enough to encourage us to develop an alternative analysis for determiner sharing.

The main drawback of Johnson's (2000) analysis, which Johnson himself explicitly points out, lies in the difficulty of generalizing the approach to shared determiners other than *few* and *no*. Recall that under Johnson's analysis, the meaning of the determiners *few* and *no* is split across two positions in the tree: the negative part of both of these determiners is base generated in a position above and separate from the quantificational part, which is base generated within the relevant DP. While it is conceivable that determiners like *every* and *most* might be similarly decomposed into a higher "hidden adverbial part" plus a quantifier part, it is harder to see how to extend this kind of lexical decomposition to determiners like *the*, *whose*, and genitive possessors, all of which may also be shared.

The proposal in Lin 2000 suffers from a more serious problem: it cannot account for the semantics of determiner sharing. The proposal relies on the presence of a single D head that

must be "shared" by corresponding NPs across conjuncts. But determiner sharing normally results in a *distributed* interpretation; that is, missing determiners are usually interpreted as if they were present in each conjunct.¹⁵ Recall that, under the Lin 2000 proposal, all of the meaning associated with the determiner is hypothesized to reside in the high D head, while none of the meaning is hypothesized to begin below at the position of the related NP (cf. Johnson 2000). It is therefore difficult to see how the meaning of the single D could be translated into a distributed D-reading.

Because of these shortcomings, I suggest another approach to determiner sharing, one which revises and extends the proposal laid out in Johnson 2000. I outline this new approach in the next section.

5.3 A New Determiner-Sharing Analysis: Extending Johnson 2000¹⁶

In revising and extending Johnson's (2000) proposal for determiner sharing, I will maintain the following aspects of his analysis: that there are two positions which are relevant for the licensing of determiners, one which sits higher in the tree (I refer to this position as DET), and one which is located within the DP itself (i.e., the head of DP, namely, D);¹⁷ and that a number of constraints interact to determine how these two positions are related to one another in the syntax and how the determiner is pronounced at PF. A crucial difference between my proposal and Johnson's lies in the way in which the meaning of the determiners is split between the upstairs and downstairs positions. Instead of locating some of the determiner meaning in the higher DET position, and some in the lower D position, I suggest that all of the determiner meaning must reside in the lower D position. The higher position is hypothesized to serve only as a licensor for the downstairs D. By splitting up the determiner information in this manner, we can avoid the questions which would be raised under Johnson's (2000) approach (e.g., if trying to split up the meaning of a determiner like *the*, what part should be upstairs, what part downstairs, and why?).

¹⁵ The interpretation of shared negative determiners across disjuncts may be an exception to this observation. The interaction between negation and disjunction is complex, however, and will not be pursued here.

¹⁶ This section has benefited greatly from suggestions made to me by Kyle Johnson.

¹⁷ For another approach to the syntax of determiners and quantifiers that relies on the relationship between higher and lower positions within a tree, see Beghelli and Stowell 1997.

This new proposal is schematized in (34). Note that we can maintain much of the structural information which was established in Lin 2000 and discussed in Section 5.2.2, such as the location of the licensing DET head below T. (By maintaining these structural details, the desirable parts of the original Johnson and Lin proposals may be maintained, in particular, the predictions regarding the dependency of determiner sharing upon Gapping and the requirement that determiner-sharing NPs be initial in their conjuncts.)

(34)

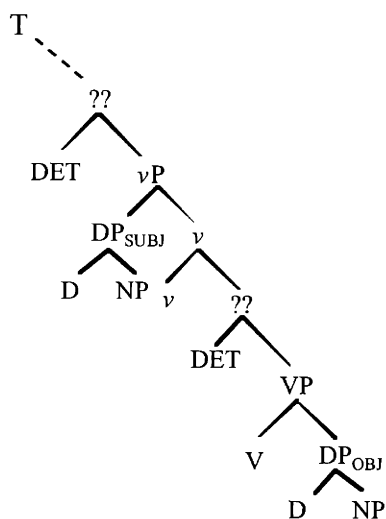

In order to account for the syntax and phonology of these determiner positions (DET and D), I adopt the constraints proposed by Johnson (2000), which we discussed in (16) and which I repeat here as (35) (with minor modification, changing Johnson's references to the negative adverb and the phonologically null indefinite to DET and D, respectively).

- (35) a. D must be within the c-command domain of DET at LF.
 b. DET must be adjoined to a DP headed by D by Spell-Out.

In addition to the constraints in (35), let us assume that there is an additional constraint governing the pronunciation of determiners at Spell Out:

- (36) If the DP containing the relevant D head is adjoined to a licensing DET at Spell-Out, it may be spelled out with lexical material; otherwise, it is realized as an unpronounced element.

This constraint on how determiners may be Spelled Out will account for the non-pronunciation of the non-initial D(s) in determiner sharing sentences. The structure for subject determiner sharing under this proposal is given in (37).

(37)

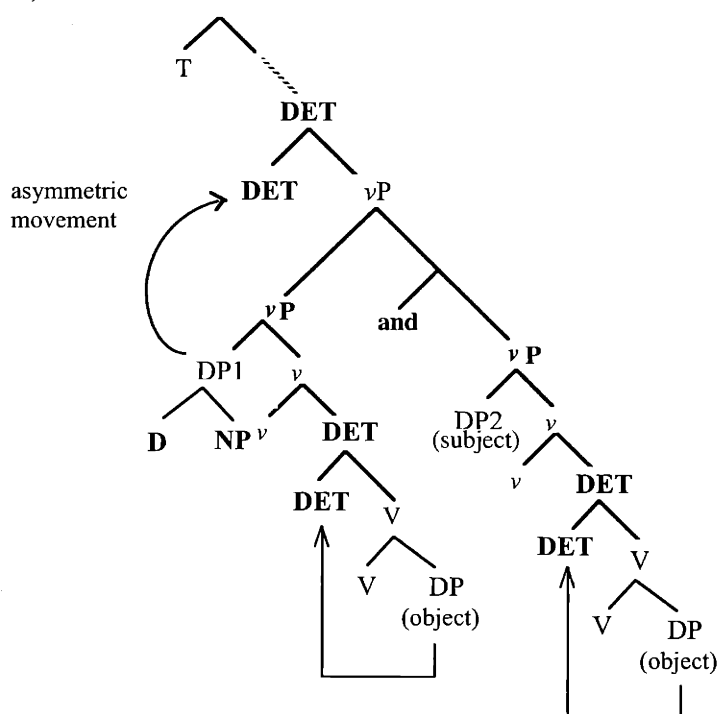

Let us consider how the constraints interact, focussing only on the subject DPs in (37). The constraint in (35a) will be satisfied by the subject-related D heads (within the base-generated DPs) if they are reconstructed to their base positions at LF (see Section 5.2.1). The constraint in (35b) will be satisfied by asymmetric movement of the first DP subject to DET. Since, at PF, the first DP is adjoined to a licensing DET, the first D will be pronounced. The second DP, which has remained in situ, will not be adjoined to a DET head, and therefore, the D head of the second subject may not be Spell-Out with lexical material.

Under this proposal, determiner sharing is the result of DET sharing, that is, coordination under a licensing DET head. The minor revisions which we have made to Johnson's proposal for determiner sharing allows for a more natural extension of the licensing idea for determiners from the negative determiners to other determiners which may also be shared. It also allows us to maintain the structures proposed in the Johnson 2000 and Lin 2000 analyses, which were shown to successively capture a number of properties of the determiner sharing phenomenon.¹⁸

In the next section, I present further evidence in favor of the logic of this general approach to the determiner sharing phenomenon, focussing on a particular puzzle raised by determiner sharing in conjoined relative clauses.

5.4 Determiner Sharing Across Possessive Relative Clauses

As mentioned at the start of this chapter, McCawley (1993) noticed an odd dependency relation in conjoined possessive relative clauses: determiner sharing (of the possessive relative pronoun *whose*) seems to depend upon Gapping (38b versus d); and at the same time, Gapping seems to depend upon determiner sharing (38c versus d).

- (38) We're looking for the child you told us about,
- a. whose brother presented a slide show, and whose sister presented a linguistics talk.
 - b. * whose brother presented a slide show, and – sister presented a linguistics talk.
 - c. * whose brother presented a slide show, and whose sister – a linguistics talk.
 - d. whose brother presented a slide show, and – sister – a linguistics talk.

¹⁸ One issue which I will not have time to consider here is how this proposal for determiner sharing interacts with the Gapping proposal of Chapter 3. Among the questions which will need to be addressed is the question of how and whether DET fits into the definition of maximal s-projection set. I believe that the interaction of the determiner sharing proposal and the Gapping proposal will not adversely affect any of the arguments which have been made for this approach to determiner sharing, but further research is required.

Again, if we examine the construction more carefully, we will see that we need to refine McCawley's generalization. Sharing of the possessive relative *whose* depends specifically upon T-sharing, not just upon Gapping, as illustrated by the paradigm in (39):

- (39) We're looking for the child you told us about,
- a. whose brother might present a slide show, and whose sister might give a linguistics talk.
 - b. * whose brother might present a slide show, and – sister might give a linguistics talk.
 - c. * whose brother might present a slide show, and whose sister – give a linguistics talk.
 - d. (?) whose brother might present a slide show, and – sister – give a linguistics talk.

Consider first the case of (39b). Given the fact that possessors may be shared (40), I assume that possessors, like other shared determiners, must be licensed by a DET head higher in the tree.

- (40) Her Mini is green, and – Honda – blue.

If this is so, then the dependency of *whose*-sharing upon T-sharing follows from the logic of coordination: *whose*-sharing requires coordination below DET, which entails coordination below T. Thus, (39b) is ungrammatical because the presence of T in the second conjunct is incompatible with the sharing of DET.

We turn now to (39c), which shows (in conjunction with (39d)) that T-sharing is dependent upon *whose*-sharing. The logic of coordination tells us that T-sharing entails C-sharing; thus, there will be only one C in the conjoined relative clause. However, the sentence has two +WH relative operators (i.e., two instances of *whose*). The presence of two +WH relative operators requires the presence of two separate C's, one to license each +WH relative operator; and in order for two C's to be present, the structure must involve CP-level coordination. If only one C is present (as T-sharing implies), the second WH-phrase *whose sister* will fail to be licensed.

(Note that *whose sister* cannot be licensed in situ, due to an independent requirement that relative operators must move overtly in the syntax (Chomsky 1995: 71; Rizzi 1990).) Thus, the ungrammaticality of (39c) stems from two conflicting requirements: the requirement imposed by T-sharing that there be only one C in the structure, and the requirement imposed by the presence of the two different relative operators that there be two C's in the structure.

The grammaticality of (39d) (repeated as (41a)), which exhibits both determiner sharing and T-sharing, follows straightforwardly from the proposed analysis of determiner-sharing structures.

- (41) a. We're looking for the child you told us about, whose brother might present a slide show, and – sister – give a linguistics talk.
- b. We're looking for the child you told us about...

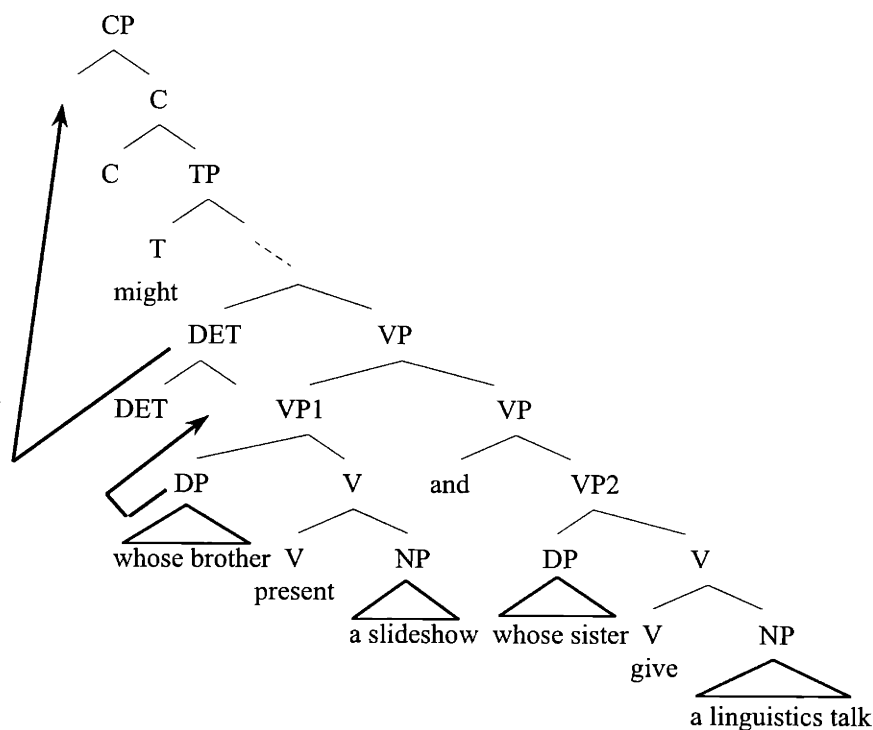

In order for *whose* to be shared, coordination must be taking place below DET. Since this entails coordination below T, T-sharing in (41a) is acceptable (in fact, it is required). Furthermore, since *whose* is shared, there is only one relative operator in the sentence; thus, the single C in the

structure is enough to take care of the licensing needs. As predicted by our account, (41a) is grammatical.

5.5 Conclusion and Further Issues

In this chapter, we have examined a type of Gapping phenomenon which at first glance appeared to be quite mysterious: McCawley's determiner sharing, in which the possibility of sharing determiners appeared to depend upon Gapping. Given what we have learned about sharing structures in the previous chapters, a closer examination of the determiner-sharing phenomenon revealed that determiner sharing patterns with a group of other constructions, all having the feature we have called necessary T-sharing. We saw that a Small-Conjunct Approach, taken together with a licensing theory of determiners, allowed us to provide an almost trivial account of the determiner sharing data, namely, that the facts of determiner sharing simply fall out of the height of coordination involved.

There are a number of questions which have not been addressed in this chapter – in particular, the question of which determiners can or cannot be shared (and why). Hand-in-hand with these questions about the determiner-sharing phenomenon are questions regarding the finer details of clausal architecture. Word-order data like the following indicate that the structures required for determiner sharing are more complicated than the ones which have been presented here:¹⁹

- (42) a. The man will arrive and – woman leave.
b. * The man will arrive and leave woman.

On the assumption that *woman* is base-generated as the internal argument of the unaccusative verb *leave* (Levin and Rappaport 1995), its appearance to the left of the verb raises a question

¹⁹ Example (42) is due to Noam Chomsky.

about the location of the subject-related DET, as well as the question of what triggers movement of the DP *woman* to the left of *leave*.²⁰

The goals of this chapter have been modest in scope: to show how the Small-Conjunct Approach, along with the concept of sharing, could be productively applied to the analysis of a particular type of Gapping phenomenon. The proposed analysis has broader implications, however, leading to interesting consequences and questions regarding the syntax of DPs and the organization of clausal architecture. These issues are left to future research.

²⁰ Note that we have seen a similar effect, namely, that in-situ subjects must move to the left edge of their conjuncts, in Chapter 3, exs, (19)–(20). Kyle Johnson makes the interesting suggestion that this required movement to the left edge may be necessary for case assignment purposes.

6. Conclusion

In this thesis, we focused on a particular syntactic structure, namely, a sharing structure, and examined its role in a variety of different syntactic phenomena. The sharing structure provided us with a tool for gaining insight into the nature of Gapping, the Coordinate Structure Constraint, and clausal architecture. Along the way, we developed a new proposal for Gapping, one which introduced the notion of a *trigger* for the application of certain deletion phenomena, and which was argued to reveal certain morpho-syntactic properties of the relationship between functional heads. We also investigated the Coordinate Structure Constraint as it applies to A-movement, and examined novel evidence that A-movement is subject to CSC effects. The effect of the CSC on the interpretation of sharing structures led us in the direction of much broader questions regarding the interaction of different constraints on the interpretation of moved material. Finally, we examined the determiner sharing phenomenon, again making use of sharing structures as a central part of the analysis of the data. The proposal for determiner sharing raises a number of questions regarding the syntax of DPs, and about clausal architecture in general.

Though it may be "small" (c.f. our discussions of the Small-Conjunct Approach to Gapping, which relies on sharing structures), the sharing structure has been shown to play a big role in our understanding of a variety of syntactic phenomena, and it has provided us with a primary tool for future investigations into these and related issues.

BIBLIOGRAPHY

- Ackema, P. and K. Szendrői. (to appear) Determiner sharing as an instance of Dependent Ellipsis, to appear in the *Proceedings of the 16th Comparative Germanic Syntax Workshop*.
- Bach, E. 1983. Generalized Categorical Grammars and the English auxiliary, in S. Davis and M. Mithun (eds.), *Linguistics, Philosophy, and Montague Grammar*, 3–49. Austin, TX: University of Texas Press.
- Bach, E. 1984. Some generalizations of categorial grammars, in F. Landman and F. Veltman (eds.), *Varieties of Formal Semantics, Proceedings of the Fourth Amsterdam Colloquium*. Dordrecht: Foris.
- Bailyn, J. F. 2001. On scrambling: A reply to Bošković and Takahashi, *Linguistic Inquiry* 32: 635–658.
- Baltin, M. 2000. Implications of Pseudo-Gapping for Binding and the Representation of Information Structure. NYU, ms.
- Beghelli, F. and T. Stowell. 1997. Distributivity and negation: The syntax of *each* and *every*, in A. Szabolcsi (ed.), *Ways of Scope Taking*, 71–107. Kluwer Academic Publishers.
- Bobaljik, J. D. 1995. *Morphosyntax: The Syntax of Verbal Inflection*. Ph.D. dissertation, MIT.
- Bobaljik, J. D. and S. Wurmbrand. 1999. Modals, raising and A-reconstruction. Paper presented at Leiden University (Oct 1999).
- Bolinger, D.. 1958. A theory of pitch accent in English, *Word* 14: 109–149.
- Bošković, Z. 1998. LF movement and the Minimalist Program, in P. Tamanji and K. Kusumoto (eds.), *NELS* 28, 43–57.
- Bošković, Z. and D. Takahashi. 1998. Scrambling and last resort, *Linguistic Inquiry* 29: 347–366.
- Chomsky, N. 1972. Some empirical issues in the theory of transformational grammar, in P. S. Peters (ed.), *Goals of Linguistic Theory*. Englewood Cliffs: Prentice-Hall Inc.
- Chomsky, N. 1993. A minimalist program for linguistic theory, in K. Hale and S. J. Keyser (eds.), *The View from Building 20: Essays in Honor of Sylvain Bromberger*, 1–52. Cambridge, MA: MIT Press.
- Chomsky, N. 1995. *The Minimalist Program*. Cambridge, MA: MIT Press.
- Chomsky, N. 2000. Minimalist inquiries: The framework, in R. Martin et al. (eds.), *Step by Step: In Honor of Howard Lasnik*. Cambridge, MA: MIT Press.
- Chomsky, N. 2001. Derivation by phase, in Michael Kenstowicz (ed.), *Ken Hale: A Life in Language*, 1–52. Cambridge, MA: MIT Press.
- Chomsky, N. 2001a. Beyond explanatory adequacy, in *MITOPL* 20: 1–28.
- Christensen, K. K. 1986. Norwegian *ingen*: A case of post-syntactic lexicalization, in *Workshop at the Ninth Scandinavian Conference*, 21–35. University of Stockholm, Stockholm.
- Collins, C. 1997. *Local Economy*. Cambridge, MA: MIT Press.
- Coppock, E. 2001. Gapping: In defense of deletion, in M. Andronis and Ball et al. (eds.). *CLS 37: The Main Session. Papers from the 37th Meeting of the Chicago Linguistic Society*. Vol. 1. Chicago: Chicago Linguistic Society.
- Culicover, P. W. and R. Jackendoff. 1997. Semantic subordination despite syntactic coordination, *Linguistic Inquiry* 28: 195–217.

- Denham, K. 2000. Optional wh-movement in Babine-Witsuwit'en, *Natural Language and Linguistic Theory* 18: 199–251.
- Doron, E. 1990. V-movement and VP-ellipsis. Hebrew University of Jerusalem, ms.
- Embick, D. and R. Noyer. 2001. Movement operations after syntax, *Linguistic Inquiry* 32: 555–595.
- Fanselow, G. 2001. Features, theta-roles, and free constituent order, *Linguistic Inquiry* 32: 405–437.
- Fiengo, R. 1974. *Semantic Conditions on Surface Structure*. Ph.D. Dissertation, MIT.
- Fox, D. 2000. *Economy and Semantic Interpretation*. Cambridge, MA: MIT Press.
- Fukui, N. and M. Speas. 1986. Specifiers and projection, *MITWPL* 8: 128–172.
- Goldsmith, J. 1985. A principled exception to the Coordinate Structure Constraint, *CLS* 21: Part I, *The General Session*, 133–143. Chicago, IL: Chicago Linguistic Society, University of Chicago.
- Grimshaw, J. 1991. Extended projections,
- Grimshaw, J. 2000. Extended projection and locality, in P. Coopmans, M. Everaert, and J. Grimshaw (eds.), *Lexical Specification and Insertion*, 115–133. John Benjamins.
- Hankamer, J. 1973. Unacceptable ambiguity, *Linguistic Inquiry* 4: 17–68.
- Hankamer, J. 1979. *Constraints on Deletion in Syntax*. New York: Garland.
- Hartmann, Katharina. 2000. *Right Node Raising and Gapping: Interface Conditions on Prosodic Deletion*. Amsterdam: John Benjamins Publishing Co.
- Heim, I. 1982. *The Semantics of Definite and Indefinite Noun Phrases*. Ph.D. dissertation, University of Massachusetts, Amherst.
- Heim, I., H. Lasnik and R. May. Reciprocity and plurality, *Linguistic Inquiry* 22: 63–101.
- Heycock, C. and A. Kroch. 1994. Verb movement and coordination in a dynamic theory of licensing, *The Linguistic Review* 11: 257–284.
- Higginbotham, J. 1991. Either/Or, *NELS* 21.
- Hudson, R. A. 1976. Conjunction reduction, gapping, and right-node raising, *Language* 52: 535–562.
- Höhle, T. 1990. Assumptions about Asymmetric Coordination in German, in J. Mascaró and M. Nespó (eds.), *Grammar in Progress*, 221–235. Dordrecht: Foris.
- Jackendoff, R. S. 1972. Gapping and related rules, *Linguistic Inquiry* 2: 21–35.
- Jayaseelan, K. A. 1990. Incomplete VP deletion and Gapping, *Linguistic Analysis* 20: 64–81.
- Johnson, K. 1991. Object positions, *Natural Language and Linguistic Theory* 9: 577–636.
- Johnson, K. 1996. In search of the English Middle Field. UMass, Amherst ms.
- Johnson, K. 2000. Few dogs eat Whiskas or cats Alpo, in K. Kusumoto and E. Villalta (eds.), *UMOP* 21: *Issues in semantics and its interface*, pp. 59–82.
- Johnson, K. 2001. What VP ellipsis can do, what it can't, but not why, in M. Baltin and C. Collins (eds.), *The Handbook of Contemporary Syntactic Theory*, pp. 439–479. Blackwell Publishers.
- Johnson, K. 2002. Restoring exotic coordinations to normalcy, *Linguistic Inquiry* 33: 97–156.
- Kathol, A. 1995. *Linearization-Based German Syntax*. Ph.D. dissertation, Ohio State University.
- Levin, B. and M. Rappaport Hovav. *Unaccusativity: At the Syntax–Lexical Semantics Interface*. Cambridge, MA: MIT Press.

- Kamp, H. 1981. A theory of truth and semantic representation, in J. Groenendijk (ed.), *Formal Methods in the Study of Language*. Amsterdam: Mathematical Center.
- Kayne, R. 1998. Overt vs. covert movement, *Syntax* 1: 128-191.
- Kitagawa, Y. 1986. *Subjects in Japanese and English*. Ph.D. dissertation, UMass, Amherst.
- Koizumi, M. 1993. Object agreement phrases and the Split VP Hypothesis, in *MITWPL* 18: *Papers on Case and Agreement I*, 99-148. Cambridge, MA: MITWPL.
- Koizumi, M. 1995. *Phrase Structure in Minimalist Syntax*. Ph.D. dissertation, MIT.
- Koopman, H. and D. Sportiche. 1985. Theta-theory and extraction, *GLOW Newsletter* 14: 57-58.
- Koopman, H. and D. Sportiche. 1991. The position of subjects, *Lingua* 85: 211-258.
- Kratzer, A. 1995. Stage-level and individual-level predicates, in G. N. Carlson and F. J. Pelletier (eds.), *The Generic Book*, 125-175. Chicago: University of Chicago Press.
- Kratzer, A. 1996. Severing the external argument from its verb, in J. Rooryck and L. Zaring (eds.), *Phrase Structure and the Lexicon*. Dordrecht: Kluwer.
- Kuno, S. 1976. Gapping: A functional analysis, *Linguistic Inquiry* 7: 300-318.
- Kuroda, S.-Y. 1988. Whether we agree or not, *Linguisticae Investigationes* 12: 1-47.
- Lakoff, G. 1986. Frame semantic control of the Coordinate Structure Constraint. In *CLS* 22, Part 2, *Papers from the Parasession on Pragmatics and Grammatical Theory*, 152-167. Chicago: Chicago Linguistic Society, University of Chicago.
- Larson, R. 1985. On the syntax of disjunction scope, *Natural Language and Linguistic Theory* 3: 217-264.
- Lasnik, H. 1981. Restricting the theory of transformations, in N. Hornstein and D. Lightfoot (eds.), *Explanations in Linguistics*. Longmans.
- Lasnik, H. 1995. A note on Pseudogapping, in *MITWPL* 27: *Papers on Minimalist Syntax*, 143-163. Cambridge, MA: MITWPL.
- Lasnik, H. 1997. A gap in an ellipsis paradigm: Some theoretical implications, *Linguistic Analysis* 27: 166-185.
- Lasnik, H. 1999. On feature strength, *Linguistic Analysis* 30: 197-217.
- Lasnik, H. 1999a. Pseudogapping Puzzles, in S. Lappin and E. Benmamoun (eds.), *Fragments: Studies in Ellipsis and Gapping*, 141-174. Oxford: Oxford University Press.
- Lasnik, H. 2001. When can you save a structure by destroying it? *NELS* 31.
- Levin, N. 1979. *Main-Verb Ellipsis in Spoken English*. Ph.D. dissertation, Ohio State University. [Reprinted in *Ohio State University Working Papers in Linguistics* 24, 65-165. 1980.]
- Lobeck, A. 1990. Functional heads as proper governors, in *Proceedings of NELS 20, Volume 2*.
- López, L. and S. Winkler. 2001. Variations at the Syntax-Semantic interface: Evidence from Gapping. University of Illinois-Chicago and Universität Tübingen, ms.
- Lin, V. 1999. Determiner Sharing. In K. Arregi, B. Bruening, C. Krause, and V. Lin (eds.), *Papers on Morphology and Syntax, Cycle One*. MIT Working Papers in Linguistics, vol. 33. Cambridge, MA: MITWPL.
- Lin, V. 2000. Determiner sharing, in R. Billerey and B. D. Lillehaugen (eds.), *Proceedings of the 19th West Coast Conference on Formal Linguistics*. Somerville, MA: Cascadilla Press.
- Lin, V. 2001. A way to undo A-movement, in K. Megerdooomian and L. A. Bar-el (eds.), *Proceedings of the 20th West Coast Conference on Formal Linguistics*, Somerville, MA: Cascadilla Press.

- Marantz, A. 1997. No escape from syntax: Don't try morphological analysis in the privacy of your own lexicon, in A. Dimitriadis, L. Siegel, et al. (eds.), *UPenn Working Papers in Linguistics*, vol. 4.2.
- Martins, A. M. 1994. Enclisis, VP-deletion and the nature of sigma. *Probus* 6: 173–205.
- McCawley, J. D. 1993. Gapping with shared operators, *Berkeley Linguistics Society* 19: 245–253.
- McCloskey, J. 1990. *Clause Structure, Ellipsis and Proper Government in Irish*. Syntax Research Center, Cowell College, UCSC.
- Merchant, J. 1999. *The Syntax of Silence: Sluicing, Islands, and Identity in Ellipsis*. Ph.D. dissertation, University of California, Santa Cruz.
- Miyagawa, S. 1997. Against optional scrambling, *Linguistic Inquiry* 28: 1–25.
- Munn, A. 1987. Coordinate structure and X-bar theory, *McGill Working Papers in Linguistics* 4: 121–140.
- Neijt, A. 1979. *Gapping: A contribution to Sentence Grammar*. Dordrecht: Foris.
- Ochi, M. 1999. Some consequences of Attract F, *Lingua* 109: 81–107.
- Oehrle, R. T. 1987. Boolean properties in the analysis of gapping, *Syntax and Semantics* 20: 201–240.
- van Oirsouw, R. R. 1987. *The Syntax of Coordination*. New York: Croom Helm.
- Pesetsky, D. 1982. *Paths and Categories*. Ph.D. dissertation, MIT.
- Pesetsky, D. 1987. WH-in-situ: Movement and unselective binding, in E. Reuland and A. G. B. terMeulen (eds.), *The Linguistic Rrepresentation of (In)definiteness*, 98–129. Cambridge, MA: MIT Press.
- Pesetsky, D. and E. Torrego. 2001. T-to-C movement: Causes and consequences, in Michael Kenstowicz (ed.), *Ken Hale: A Life in Language*, 355–426. Cambridge, MA: MIT Press.
- Pollock, J.-Y. 1989. Verb movement, Universal Grammar, and the Structure of IP, *Linguistic Inquiry* 20: 365–424.
- Postal, P. M. 1998. *Three Investigations of Extraction*. Cambridge, MA: MIT Press.
- Progovac, L. 1998a. Structure for coordination: Part I, *Glott International*, vol. 3, Issue 7, September.
- Progovac, L. 1998b. Structure for coordination: Part II, *Glott International*, vol. 3, Issue 8, October.
- Rodman, R. 1976. Scope phenomena, "movement transformations," and relative clauses. In Barbara Partee, ed., *Montague Grammar*, 165–176. New York: Academic Press.
- Rooth, M. 1992. Ellipsis redundancy and reduction redundancy, in S. Berman and A. Hestvik (eds.), *Proceedings of the Stuttgart Ellipsis Workshop*. IBM Germany, Heidelberg.
- Ross, J. R. 1967. *Constraints on Variables in Syntax*. Ph.D. dissertation, MIT. [Reproduced by the Indiana University Linguistics Club. 1968. Bloomington, Indiana.]
- Ross, J. R. 1969. Guess who? In R. I. Binnick, A. Davison, G. M. Green, and J. L. Morgan (eds.), *Papers from the Fifth Regional Meeting of the Chicago Linguistic Society*, 252–286. Chicago: Chicago Linguistic Society, University of Chicago.
- Sag, I. 1976. *Deletion and Logical Form*. Ph.D. dissertation, Massachusetts Institute of Technology.
- Sag, I., G. Gazdar, T. Wasow, and S. Weisler.. 1985. Coordination and how to distinguish categories, *Natural Language and Linguistic Theory* 3: 117–171.

- Saito, M. and K. Murasugi. 1990. N'-Deletion in Japanese, in *UConn Working Papers in Linguistics* 3: 87–107.
- Schwarz, B. 1998. On Odd Coordinations in German, *Journal of Comparative Germanic* 2: 191–219.
- Schwarz, B. 1999. On the syntax of *either...or*, *Natural Language and Linguistic Theory* 17: 339–370.
- Siegel, M. 1984. Gapping and interpretation, *Linguistic Inquiry* 15: 523–530.
- Siegel, M. 1987. Compositionality, case, and the scope of auxiliaries, *Linguistics & Philosophy* 10: 53–75.
- Tancredi, C. 1992. *Deletion, Deaccenting, and Presupposition*. Ph.D. dissertation, MIT.
- Vainikka, A. 1987. Why can *or* mean *and* or *or*? in J. Blevins and A. Vainikka (eds.), *UMOP* 12: *Issues in Semantics*, 148–186. Amherst, MA: GLSA, University of Massachusetts, Amherst.
- Wilder, C. 1994. Coordination, ATB and ellipsis, in J-W. Zwart (ed.), *Minimalism and Kayne's Antisymmetry Hypothesis*, 291–331. Groningen. [*Groninger Arbeiten zur Germanistischen Linguistik* 37]
- Wilder, C. 1997. Some properties of ellipsis in coordination, in A. Alexiadou & T. A. Hall (eds.), *Studies on Universal Grammar and Typological Variation*, 59–107. Amsterdam: John Benjamins Publishing Co..
- Williams, E. 1978. Across-the-Board rule application, *Linguistic Inquiry* 9: 31–43.
- Williams, E. 1997. Blocking and anaphora, *Linguistic Inquiry* 28: 577–628.
- Zagona, K. 1982. *Government and Proper Government of Verbal Projections*. Ph.D. dissertation, University of Washington.
- Zoerner, C. E. I. 1995. *Coordination: The Syntax of &P*. Ph.D. dissertation, University of California–Irvine.