

**Household Water Treatment and Safe Storage
Product Development in Ghana**

ARCHIVED

by

Shengkun Yang

B.S. Civil Engineering
University of Washington, 2012

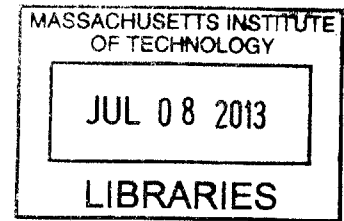

SUBMITTED TO THE DEPARTMENT OF CIVIL AND ENVIRONMENTAL
ENGINEERING IN PARTIAL FULFILLMENT OF THE REQUIREMENTS FOR THE
DEGREE OF

MASTER OF ENGINEERING IN CIVIL AND ENVIRONMENTAL ENGINEERING
AT THE
MASSACHUSETTS INSTITUTE OF TECHNOLOGY

JUNE 2013

© 2013 Massachusetts Institute of Technology. All Rights Reserved.

Signature of Author: _____
Shengkun Yang
Department of Civil and Environmental Engineering
May 17, 2013

Certified by: _____
Susan Murcott
Senior Lecturer of Civil and Environmental Engineering
Thesis Supervisor

Accepted by: _____
Heidi M. Nepf
Chair, Departmental Committee for Graduate Students

Household Water Treatment and Safe Storage Product Development in Ghana

by

Shengkun Yang

Submitted to the Department of Civil and Environmental Engineering on May 23rd, 2012, in Partial Fulfillment of the Requirements for the Degree of Master of Engineering in Civil and Environmental Engineering

ABSTRACT

Microbial and/or chemical contaminants can infiltrate into piped water systems, especially when the system is intermittent. Ghana has been suffering from aged and intermittent piped water networks, and an added barrier of protection is needed for improved public health. Household water treatment and safe storage (HWTS) products, such as ceramic pot water filters, can be great complements to piped water systems. This thesis focuses on developing a new household water treatment product, targeted middle and upper class families, to help provide safe and affordable drinking water in Ghana at the household scale.

Pure Home Water (PHW), a registered nonprofit organization in Tamale, Ghana, manufactures and disseminates a ceramic pot water filter called “AfriClay Classic Filter”. This thesis project was conducted in partnership with PHW to research and develop a new product to be branded as “AfriClay Deluxe Filter”, and serve as a high-end product in urban areas.

The research and development process has consisted of analysis of alternative products in the global market, selection of designs, field research and proof of concept, selected products evaluation, and final design recommendations. Four HWTS products have been studied and analyzed thoroughly. The field research was done in January 2013 in Ghana, and included 40 household surveys and multiple field trips to a local water treatment plant, plastic manufacturers, and Ghana Water Co Ltd, the national piped water-supply agency in Accra. The products analyses and field research data are then synthesized in two products assessments and final recommendations are made. In addition, this thesis documented PHW’s concrete mold-making process, which is an essential step of manufacturing the clay filter element.

At the end of the study, a new filter model as well as several product features is recommended to PHW. The organization may either use the new filter model as its high-end product, or take the recommended product features forward for further development.

Thesis Supervisor: Susan Murcott

Title: Senior Lecturer of Civil and Environmental Engineering

Page intentionally left blank.

Acknowledgement

It's been an amazing year since September 2012. With the incredible support I received at MIT, I have achieved so many life goals that I never imagined before. I'd like to thank the following individuals who have assisted me to reach where I am today:

Mom and Dad: Whenever, wherever I need help, you were always there for me. You have provided me with a perfect balance of support and challenge: supporting me to overcome hardship, and challenging me to achieve more and better. Every time I see you at the other end of Skype, I feel calm and become clear of my goals ahead. Thank you for everything.

Susan Murcott: Thank you for this wonderful year! I was very much drawn to the Ghana project not only for its exotic experience and humanitarian mission but also for you as an empathic, knowledgeable, and helpful mentor. You have provided me with great support and pulled me through my most stressful time of the year. Education, love, and career, three of the best things in life have worked my way fantastically well. Thank you so much for your guidance! I also really appreciated the opportunity to know your work and Pure Home Water. In addition to the tremendous amount of knowledge I was taught, I become aware of how privileged I am, studying in the US and living up to my dreams. This motivates me to carry on the hard work every morning I wake up. Thank you for this experience! Best wishes to you and PHW!

Keting (Joy) Su: This year would have been so long without your understanding and support. No one could have understood how hard it's been for us! Together, we have made it through and proved how much positive energy love can bring us in spite of distance, uncertainties and inequalities. It's my good fortunate to have met you.

Windsor Sung: Thank you for the interesting class: Water and Wastewater Treatment Engineering. You have made it one of my most enjoyable classes in the program. Because of the knowledge you taught me, I'm very confident to start a career in this industry. Thank you for being my great first teacher of this course.

Eric Adams, Harold Hemond, Charley Harvey, Peter Shanahan, David Langseth: Thank you for this wonderful program. Your dedication is lifting ten of hundreds of young engineers to achieve their dreams. I see a transformation in myself over the last year. Thanks for this opportunity.

Jonathan Lau and Connie Lu: Thank you for your support during my job search. As fellow Asians, you probably are aware of the challenge for me to find a job, and remain in the US.

During my most difficult time, you have pulled me up and helped me every way you could. I will deeply remember and feel thankful for such support in the rest of my life.

Kristine, Deborah, and Kate: Thank you for this wonderful team! I very much enjoyed our time over the past year and in Ghana. You guys have made it such a pleasant and interesting experience for me. And I have learned a lot from all of you. Thank you and I will surely miss this team in my career.

My other MEng classmates: Thank you for the sincere friendship you all developed and maintained with me. I will never forget the hard work and fun we had together. May our friendships continue for the rest of our life!

Abel Manangi and George Neequaye: Thank you for the company in Ghana. We have formed a great survey team together. With you guys, I never felt foreign for my first visit in Africa! I also appreciate your help for the business plan competition. Without your support and participation, we would never have made it so far!

Emmanuel Brace and the Brace family: Thank you for hosting me during my time in Ghana. You have shown me the renowned Ghanaian hospitality. It was a memorable time living in your family and experiencing the local culture. I miss the laughter we had together, and I also miss the food from Mrs. Brace! Thank you for making my first African trip so pleasant.

Pat Lennon: Thank you for providing me with valuable information on Super Tunsai and C1 Common Interface. I appreciated your time to meet with me and to show me the various filter models in the PATH lab. This project wouldn't be so smooth without your help and introduction.

Page intentionally left blank.

Table of Contents

List of Figures	10
List of Tables	13
Abbreviations and acronyms.....	14
1. Introduction	15
1.1 The Republic of Ghana	15
1.2 Drinking Water in Ghana	16
1.3 Household Water Treatment and Safe Storage (HWTS) as a complement to intermittent piped water supplies	16
1.4 Pure Home Water (PHW).....	17
1.5 AfriClay Deluxe Filter: New Product Development Background.....	18
2. Goal and Objectives:.....	19
3. Literature Review	20
4. Methodology:	27
4.1 Product Benchmarking.....	27
4.2 Field Research	29
5. Products Descriptions:.....	31
5.1 Hydrologic and its Products: Tunsai/Super Tunsai.....	31
Hydrologic	31
Tunsai Filter	31
Extended User Testing.....	32
Super Tunsai Filter.....	33
5.2 C1 Common Interface.....	38
PATH visit.....	39
PureEasy visit	41
5.3 AfriClay Classic Ceramic Pot Filter.....	44
Technology	44
Organization’s Name and Contact Info	47
5.4 Ecofiltro.....	49
6. Concrete Molding Making Process.....	51
7. Results	69
7.1 Household Survey Results.....	69
Primary Water Source.....	69
Customer Preferences of HWTS Products.....	70
Price to Purchase-C1 Common Interface	71
Preferred Distribution Channel.....	72

7.2 Products Assessment	74
First-round Assessment Design Criteria.....	74
Second-round Assessment.....	77
Additional Analysis	78
8. Distribution of AfriClay Deluxe Filter: A Business Strategy	80
Break Even Analysis	80
5-year demand forecasting for Tamale, Ghana	83
Supply Chain Bottleneck Analysis	85
9. Conclusion	88
10. Recommendations	89
10.1 Recommendations for Further Developing AfriClay Deluxe Filter Product	89
10.2 Vision Statement for AfriClay Deluxe Filter	92
10.3 Challenges and Recommendations for Future Studies	93
Time and Economic Limitations	93
Data Limitation	93
Recommendations for Future Studies.....	93
Bibliography	95
Appendices	98
Appendix A: Instruction for Assembly of C1 Common Interface	98
Appendix B: Household Survey	99
Appendix C: Product Assessment: Financial Analysis Spreadsheet	107
Appendix D: FM Making Dimensions	108
Appendix E: Mold Making Material List	110
Appendix F: Mold Making Tools Dimensions	111
Appendix G: Ghana Microfinance Institutions Information	113
Appendix H: Mold Making: Communication Records with Manny Hernandez	114

List of Figures

Figure 1: Map of Africa and Map of Ghana.....	15
Figure 2: Northern Ghana Drinking Water Sources.....	16
Figure 3: AfriClay Classic Filter Concerns.....	27
Figure 4: Shengkun Yang conducting survey at A&C Mall, East Legon, Accra.....	30
Figure 5: George Neequaye conducting survey at a household, East Legon, Accra.....	30
Figure 6: Tunsai CWP.....	31
Figure 7: Super Tunsai Design Team.....	35
Figure 8: Tunsai and Super Tunsai.....	37
Figure 9: C1 Common Interface.....	38
Figure 10 Chinese Filters in PATH lab in Seattle.....	39
Figure 11: C1 Common Interface Filters from China.....	40
Figure 12: PureEasy Filter and Filter Element.....	41
Figure 13: NMC.....	42
Figure 14: Sideway Style (PureEasy) Figure 15: Pancake Style (PureEasy).....	43
Figure 16: AfriClay Classic Filter + Filter Mechanism + Hemispherical-shaped Clay Pot Filter Element.....	44
Figure 17: AfriClay Classic Filter with Lid, and Tap.....	45
Figure 18: AfriClay Classic Filter Element Dimensions (in inches).....	48
Figure 19: Ecofiltro ceramic pot water filters. Photo credit: Ecofiltro.....	50
Figure 20: Pure Home Water's 1 st Mani Press showing FM and MM.....	51
Figure 21: Sheet Metal Cone.....	52
Figure 22: Wooden Template A.....	53
Figure 23: Wooden Template B.....	53
Figure 24: Item A.....	54

Figure 25: Item B	54
Figure 26: Item C	55
Figure 27: Male Mold Cavity	55
Figure 28: Trapezoidal Template	56
Figure 29: C Channel	56
Figure 30: TT Dimensions (in inches)	58
Figure 31: Welding steel rod to the base ring	59
Figure 32: Making the steel rings	59
Figure 33: Metal cage, not yet finished Figure 34: Metal cage, with threaded rods.....	60
Figure 35: Finished metal cage.....	61
Figure 36: Preparing and applying clay onto the Item A.....	62
Figure 37: Rotating Item B to make the shape of the prototype filter element	62
Figure 38: Finished prototype filter element.....	63
Figure 39: Metal cage over prototype; Item C around base of steel ring.....	63
Figure 40: Metal cone around the cage, and secured with wires Figure 41: Pouring concrete	64
Figure 42: Finished Female Mold, except that the hole is unfilled	65
Figure 43: FM Making Cross Sectional View.....	65
Figure 44: On the underside of Wooden Template A Figure 45: Apply Vaseline to Male Mold Cavity.....	66
Figure 46: Wooden Template A at the center of Male Mold Cavity	67
Figure 47: After pouring concrete into the cavity	67
Figure 48: Removing the male mold	68
Figure 49: Finished female mold (left) and male mold (right)	68
Figure 50: Primary Water Source in Accra and Kumasi.....	69
Figure 51: Customer Preferences of HWTS products	70
Figure 52: Price customers willing to pay for C1 Common Interface Filter.....	71

Figure 53: Customers' preferred distribution channels/purchasing methods	72
Figure 54: Break Even Time vs Sales Price	82
Figure 55: Break Even Quantity vs Price.....	83
Figure 56: 5-year Demand Forecasting in Tamale at \$30 per unit	85
Figure 57: Major Components of AfriClay Deluxe Supply Chain	86
Figure 58: Six concepts for Super Tunsai Filter	94
Figure 59: Male Mold Cavity AutoCAD Drawing (in inches).....	111
Figure 61: Wooden Template B AutoCAD Drawing (in inches)	112

List of Tables

Table 1: PHW's AfriClay Classic Filter Performance	17
Table 2: Customer Preferences on HWTS Products	18
Table 3: Comparison of plastic container and ceramic container	28
Table 4: Survey neighborhoods in Ghana.....	29
Table 5: Super Tunsai Price Information	36
Table 6: Hydrologic's Revenues and Costs in MFI Sales Model	36
Table 7: Comparison of Tunsai and Super Tunsai	37
Table 8: Sideway vs Pancake filter elements (PureEasy).....	43
Table 9: Geometric means of total coliform, E. coli, and turbidity.....	45
Table 10: Products Assessment Matrix (design criteria).....	75
Table 11: Product Assessment Matrix (financial criteria).....	77
Table 12: Comparison of Economy: Ghana vs Cambodia.....	80
Table 13: Cost estimates for AfriClay Deluxe Filter	81
Table 14: Break-even analysis for the pilot.....	81
Table 15: Break Even Analysis for Local Production	83
Table 16: 5-year Demand Forecasting in Tamale	85

Abbreviations and acronyms

E. coli	Escherichia coli
GHS	New Ghana Cedi (USD 1 = GHS 2.00, 5/8/13)
HWTS	Household Water Treatment and Safe Storage
IDE	International Development Enterprises
MEng	Master of Engineering
MIT	Massachusetts Institute of Technology
MGD	Millennium Development Goal
NGO	Non-Governmental Organization
PHW	Pure Home Water
POU	Point-of-Use
SODIS	Solar Water Disinfection
UNICEF	United Nations Children's Fund
WHO	World Health Organization
WTP	Willingness to pay
WASH	Water, Sanitation and Hygiene
FM	Female Mold
MM	Male Mold
MP	Mani Press

1. Introduction

1.1 The Republic of Ghana

Ghana, a West African country located in the Gulf of Guinea, has a population of about 24 million (CIA, 2012). The total area of Ghana is 238,535 km² (92,098 mi²). The top three largest cities in Ghana are Accra, Kumasi, and Tamale, contributing to 20% of the total population in the country. The word Ghana, derived from the ancient Ghana Empire, means “Warrior King” (Jackson, 2001). Only a few degrees north of the Equator, Ghana has a warm climate throughout the year (see Figure 1-1).

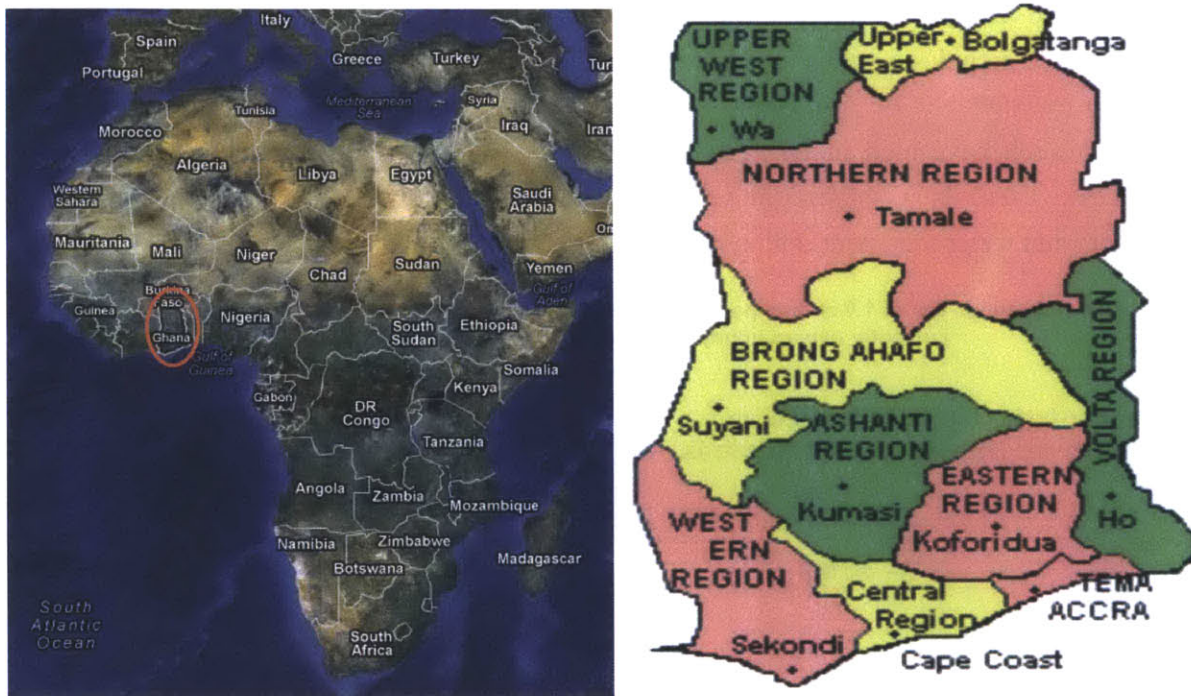

Figure 1: Map of Africa and Map of Ghana (Credit: Google Map, GhanaWeb)

Since its independence in 1957, Ghana has been a parliamentary democracy, followed by alternating military and civilian governments. Military government gave way to the Fourth Republic after presidential and parliamentary elections in late 1992. Ghana is a Lower-Middle Income Economy and 27% of its population was living on less than \$1.25 per day by 2011 (World Bank, 2011). The native and largest ethnic group is Akan, as of 2012, 45.3% of the population is Akan (CIA, 2012). English is the official language, and Akan is the largest native language. However, there are some 60-70 other local languages spoken by different tribal and ethnic groups throughout the country.

Ghana is a member of the United Nations, the Commonwealth of Nations, the South Atlantic Peace and Cooperation Zone, La Francophonie, the African Union, and the Economic Community of West Africa States (World Bank, 2011).

1.2 Drinking Water in Ghana

Ghana is currently officially “on track” for reaching water Millennium Development Goal for improved water by 2015 (UNICEF/WHO), but nonetheless has significant populations especially in the northern part of the country with unmet needs for safe drinking water (Murcott, Request for Proposal: Ghana Project, 2012).

Over 50% of the population in Northern Ghana lack access to safe drinking water, and use unimproved water, i.e. surface water, as drinking water sources (See Figure 1-2). An improved source includes a public standpipe or outdoor tap, a protected well, a protected spring, or rainwater (WHO/UNICEF 41). However, these sources don’t completely prevent water borne diseases. Children have high mortality rates and serious health issues due to the lack of safe water access. There is a substantial need for not only “improved” but also “safe” water management and water treatment options in Northern Ghana.

50% (0.9 million out of 1.8 million people) in Northern Region, Ghana currently use an unimproved source

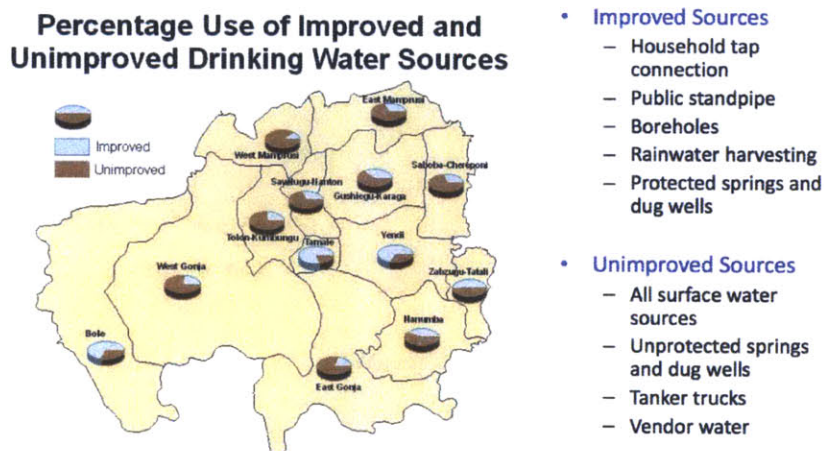

Figure 2: Northern Ghana Drinking Water Sources (Credit: VanCalcar, 2006)

1.3 Household Water Treatment and Safe Storage (HWTS) as a complement to intermittent piped water supplies

Microbial and/or chemical contaminants can infiltrate into piped distribution systems, especially where water is supplied intermittently, such as in Ghana. The low water pressure, creating an intermittent distribution system, will allow the ingress of contaminated water into the

system through breaks, cracks, joints and pinholes (WHO, 2012). The situation is highly likely to occur in Ghana due to its aged piping network. Water flowing out of the tap is potentially contaminated and requires additional treatment for drinking. Therefore, an added barrier of protection against contamination is desired for drinking water treatment in developing countries like Ghana. HWTS products can provide that additional barrier of protection.

Maintaining a disinfectant residual throughout the distribution system can provide some protection of recontamination; but it can also mask the detection of contamination through the use of conventional fecal indicator bacteria such as *E. coli*, particularly by resistant organisms (WHO, 2012). A viable control measure can be utilizing household water treatment products, one example of which is porous ceramic or composite filters. These filters rely on physical straining through a porous surface to remove microbes by size exclusion. Some filters are coated with colloidal silver, which is bactericidal and kills contaminated microbes during the filtration process.

In Ghana where piped water suffers from recontamination, HWTS product creates an additional barrier of protection, and therefore serves as a first line of treatment and protection for those using unimproved water supplies and an additional barrier of protection for those with intermittent piped water supplies.

1.4 Pure Home Water (PHW)

Pure Home Water (PHW) is a registered nonprofit organization in Tamale, Ghana. Since its inception in 2005, PHW has been providing household water treatment techniques in Northern Ghana. The organization has two goals: 1) provide safe drinking water, sanitation, hygiene (WASH) in Ghana, especially to those most in need in Northern Ghana; 2) become locally and financially self-sustaining. To meet these goals, PHW has developed a ceramic water filter called AfriClay Classic Filter. This filter has been effective at pathogen removal and treating household drinking water. Having reached out 100,000 people through dissemination of the AfriClay Classic Filter, the organization has achieved some success with meeting its first goal, however, it has struggled, unsuccessfully so far, to at least break even on expenses to meet its second goal.

Table 1: PHW's AfriClay Classic Filter Performance

Flow Rate	Bacteria Removal	Turbidity Reduction
2-7 L/hour	99%	80%

1.5 AfriClay Deluxe Filter: New Product Development Background

PHW sold over 2200 AfriClay Classic Filters in 2012, most of which are sold to large NGOs and agencies such as UNICEF and Rotary International. And those organizations have worked with PHW and District Assemblies (DA) to disseminate the AfriClay Classic Filters in rural villages of Northern Region Ghana for free. Currently, AfriClay Classic Filter is the only filter model from PHW. Though the retail price is slightly higher than the production cost, the organization still runs at a deficit each year. In order to help PHW become financially self-sustaining, the development of a new product, the AfriClay Deluxe Filter, is proposed. PHW intends to design the AfriClay Deluxe Filter and disseminate among the middle and upper income communities at a higher price. The deluxe model is expected to create profits to subsidize the fixed cost from the classic model.

Intrinsically, the new product is desired to help PHW achieve the goal of becoming financially self-sustaining. Extrinsically, it's expected to be well received in the market. According to previous Master of Engineering (MEng) studies. A 2012 MEng student, Weini Qiu researched six HWTS products in Ghana, of which a hypothetical deluxe model ranked most popular HWTS product among interviewed potential middle class customers.

Table 2: Customer Preferences on HWTS Products (Qiu, 2012)

Rank	Product	Score
1	AfriClay Deluxe	174
2	AfriClay Classic	142
3	Life Straw Family	88
4	PUR	70
5	Aquatab	53
6	CrytalPur/Tulip Siphon Water Filter	51

2. Goal and Objectives:

The goal of this thesis research is to develop a new household water treatment product in Ghana. This new product, targeting middle and upper income families, will be branded “AfriClay Deluxe”. It serves as a high-end water treatment product for PHW, and helps the organization achieve its two goals as described in the introduction.

In order to achieve the thesis research goal, this research and development project has the following objectives:

1. Conduct a household survey and characterize consumer preferences for HWTS products,
2. Assess PHW’s current AfriClay Classic Filter product and a small selection of three other HWTS products in the global market that are or could be readily available in Ghana,
3. Evaluate the four products against multiple criteria and analyze a distribution model of the AfriClay Deluxe Filter,
4. Document the concrete molding making process to facilitate new product development on site at the PHW factory in Taha, Ghana. This document transfers the mold making capability to skilled PHW workers.

3. Literature Review

A review of the following articles has been completed in order to assist the author in understanding new water filter development in Ghana.

John Sutton & Bennet Kpentey (2012). An Enterprise Map of Ghana. Chapter 15: Plastics and Rubber

The plastics industry in Ghana manufactures products such as consumer products and prescription containers, fiberglass and composite materials, plastic compounds and resins, and household products. In Ghana, the plastics industry imports all its inputs.

The plastics industry is composed of three segments: pipes, household plastic wares, and plastic sachets, bottles and packaging. According to the book, the two major domestic companies in the household plastic ware segment are Interplast Ltd and Qualiplast Ltd. Their products compete against a substantial flow of imports, especially from China. There are other domestic companies with smaller sizes, such as Dechlorplast Ltd, Strongplast Ltd, Bestplast Ltd, etc.

In the plastics industry, the main inputs are plastic granules, metal sheets/rolls, paper master rolls, film master rolls and various chemicals, all of which are imported from China, India, Brazil, South East Asia and the Middle East. The current import tax regime imposes a tax of almost 40% on imported products to protect the local industry from these cheaper imported plastic products from China and elsewhere.

Interplast Ltd and Qualiplast Ltd are the two major manufacturing firms in Ghana. Interplast operates under three brand names: Interplast for pipes and fittings, Everplast for reinforced plasticized polyvinyl chloride (uPVC) doors, windows and profiles, and Panelplast for wall and ceiling panels. Qualiplast supplies industrial packaging containers and household plastic wares to both local and international markets. In terms of filter containers, Qualiplast has a high manufacturing capacity. This company has a state-of-the-art plant and more than 150 types of equipment and molds, as well as a strong team of engineers, chemists, technicians and operators. Its international network allows it to source any type of complex mold. Qualiplast imports the raw materials mainly from Brazil, the US, and Saudi Arabia.

Vanessa Green (2008). Household Water Treatment and Safe Storage Options for Northern Region Ghana: Consumer Preference and Relative Cost

Household water treatment and storage (HWTS) products have been available to a small extent in Northern Region Ghana for the past 8~10 years; however, there had been a low adoption rate. In order to find out a method to help HWTS implementing organizations stimulate product uptake and adoption, a consumer preference study was conducted by MEng student, Vanessa Green (2008). This study consisted of a customer preference survey and water quality testing in 237 households around Tamale.

For HWTS options, solar disinfection, chlorination, particle removal options, combined system options, and sachet water were considered. AfriClay filter, a ceramic pot filter, belongs to the particle removal option category (filtration and flocculation). Household scale filtration uses inexpensive local materials such as clay or sand to treat water, and it's attractive for low-income communities. However, such products require technical expertise to build and proper training to operate and maintain, which has been a major concern for continuous use.

The features tested in Green's study include water look, water taste, product look, product durability, health impact, treatment time, and price. A set of images were developed to depict the choices to the target audience. Health improvement proved to be the most important feature of the product, followed by product type (attractiveness). Time to treat, water taste and look, and product price didn't show a strong preference from the respondents. In rural communities, dugout, boreholes and rainwater are the main water sources, whereas in urban communities, rainwater collection and private household taps are the main water sources.

When conducting the survey, the team was faced with challenges such as the high levels of illiteracy and weak numeracy skills among respondents. Additionally, the frequent transition from one respondent to another based on question type also created challenges. This made it difficult for the surveyor to record accurate data and response. Recommendations from the team include using pictorial representation and presenting a reasonable number of tasks. Respondent fatigue was observed around task screen 3-4, and respondents went through options more quickly for additional tasks beyond it.

Vanessa Green's thesis provides the author with valuable information in terms of survey methodology and implementation in Northern Region Ghana. The survey training advice and other recommendations have been directly applicable to our team (Shengkun Yang, Abel Manangi, and George Neequaye) and our survey in Ghana.

PATH (2012). Sparking Demand for Household Water Treatment Products

Since 2006, Safe Water Project (SWP) at PATH has been seeking new ways to stimulate a robust and sustainable commercial market for HWTS products in developing countries. The key components of the project are to extend access to meet the needs of low-income consumers and to promote purchase and use of water treatment products. Generating demand for new and unfamiliar products is one of the barriers. The pilot projects indicates that product design, pricing, and sales channels all greatly affect the demand, however, promotion is the primary method to create interest and stimulate the market.

Promotion can be done at two levels: the brand level and the category level. At the brand level, promotion focuses on the specific product and tailors strategies accordingly. At the category level, promotion focuses on the benefits of household water treatment and safe storage generally. In places where there is lots of competition, brand level is utilized since category level campaign requires coordination with competitors. In Ghana, HWTS is a nascent market and there are few competitors within the country, so both brand level and category level promotion should be useful.

PATH's pilot activities were undertaken in Cambodia, India, Kenya, and Vietnam. The business models include retail sales with coupons, direct sales door-to-door, village micro financing, direct sales by mobile sales agents, and direct sales by government health staff.

The paper also discussed the six stages in the consumer purchasing process. In the "pre-awareness stage", consumers are not interested in HWTS products because they are not aware of the problem. In the "perceived need" stage, consumers perceive a need for treated water for various reasons, such as aesthetics, convenience, social aspirations or health impact. In the "seek information" stage, they seek information about the product by available means. In the "decide stage", customers weigh options of the products, and decide which one they would purchase. Then in the "purchase stage", consumers seek the product at the right price and buy it. Micro financing is a good purchasing option for most developing countries due to the limited financial capability. The last stage of the process is to use the product properly. How well do the customers operate and maintain the product and how frequently do they use it depends on the users' experience with it. A good product should be user-friendly while providing all the functionalities.

The paper also provided recommendations for HWTS sales: In most cases, HWTS products are a hard sell; a combination of health and aspirational messaging is needed. While mass media can help raise awareness, interpersonal communication remains the most effective

sales method. The greatest opportunities for learning and market expansion will come in situations where consumers are presented with multiple, comparable product options.

Urs Heilerli (2006). Why is it so hard to bring safe water to the poor and so profitable to sell it to the rich? The marketing challenges for point of use water treatment devices

It struck me to hear that in many developing countries, water is taken out of the ground and sold at a price higher than wine, milk and even oil.

Unclean water and poor sanitation is the world's second largest killer of children. In contrast, bottled water consumption has been growing rapidly in urban communities. That means that on the one hand, people from rural areas are suffering from water-borne diseases due to lack of affordable water, whereas people in urban areas are drinking too expensive bottled water. There has been a gap between the rich and the poor in safe water. Although there may be little market for bottled water among the lower class, the middle class markets are booming, especially in Asia.

The article claims that the scandal is that the poor are deprived of safe water. Safe water contributes to a reduction in diarrheal diseases, but the links between safe water and health are more complex and not straightforward: 1. Water availability is more important than water quality¹ 2. Quality and irregularity of water supply is disastrous for the poor 3. Hygiene promotion is a subtle social process 4. Burden of environmental diseases: The main causes of diseases among children in developing countries are diarrhoeal diseases, lower respiratory infections, malaria, etc.

Household water treatment products are point of use (POU) devices. According to the article, marketing POU devices faces two major challenges: 1. Tagging on an educational message: people don't link incidences of diarrhea to contaminated water. 2. Working with prestige and status: it is often more cost-effective to rely on social ambitions rather than on health arguments to motivate people to adopt better hygiene.

The article also raised a few good points about customer preferences: Do people prefer to boil or not boil the water? How closely related is willingness to pay and ability to pay? How much time do people have for treating water (is cheaper and slower really better)? How long are POU's in use and why do they break down? If people are not aware of the importance of clean

¹ Esrey MetaAnalysis (1985,1991), 67 studies from 28 countries. In comparison, Fewtrell & Colford MetaAnalysis (2004) concluded quite differently from Esrey's study: water quality shows a substantial higher reduction of diarrhea disease compared to water supply

water, to whom would they listen and who can influence them? This is an important consideration for promotion.

Access to Safe Water for the Bottom of Pyramid: Strategies for Disseminating Technology Research Benefits, Society for Technology and Action for Rural Advancement (TARA), 2012

Nearly one billion people at the bottom of pyramid lack access to safe water supply. Of 3.5 million people dying each year from water related diseases, 84% are children and 98% occur in the developing countries. Nanotechnology has the potential to solve the problem, however, enabling access to the technologies for these 3.5 million who suffer most remains a big challenge. Nano materials can effectively remove bacteria, viruses, protozoa, pesticides, heavy metals and inorganic contaminants, but it hasn't captured the imagination or market among consumers. The key reason is the lack of awareness among the target group. There exists a gap between the availability of the (nano) technologies and the population in need of such technologies. The article explores the application of nanotechnology for water purification for the Bottom of Pyramid² (BoP) population. The author has also undertaken this study to understand the supply chain and the life cycle of the products in different domains so that the findings can be incorporated in the final pilot. Product design, standards and practices for quality assurance, awareness, safety aspects are also looked into from each stakeholder's point of view.

The majority of the nano-based technologies penetrating into the market are silver-based technologies. The six technologies analyzed in the article include Puritech, Aquaguard Total Infinity, TATA Swach Smart, Pureit, Lifestraw Family and Tulip Siphon Water filter. The six technologies are analyzed in terms of technical, environmental, and economic parameters. Although the filters have been introduced in the market of developing countries for almost eight years, there still is a lack of penetration in the BoP markets.

In addition to the technologies in the market, there is a wide range of nano-based research being carried out across the world. The research at Stanford produces a filter that doesn't trap the bacteria; it lets them pass through the highly conductive nano-coated cotton, and uses electrical pulses to inactivate bacteria by poking holes in their cell walls. This filter can make the process over 80,000 times faster than existing filters in terms flow rate. Researchers at the University of Aberdeen have been developing a technology that uses a sunlight-powered catalyst to treat contaminated water. This technology not only purifies water but also creates electricity. At

² A term referring to the largest but poorest socio-economic group constituting more than 2.5 billion people that live on less than \$2.5 per day

Stellenbosch University, researchers have come up with an inexpensive, teabag-like sac of Nano-fibers that purifies the water when water passes through it. The filter is most suitable for cleaning running river water in rural areas where there is no contamination from heavy metal and direct disposal of untreated sewerage. Indian Institute of Technology's (IIT) research focuses on surface-engineered nano particles to detect and separate toxic metal and organic dyes. They have recently investigated magnetic nanoparticles³ (MNP) to resolve environmental problems, such as toxic metal ions and radioactive elements removal, microbial pathogens and organic dyes capturing, acceleration of coagulation of sewage, and remediation of contaminated soils. IIT Chennai has also been looking at the possible use of noble nanoparticles for water purification. Their study focuses on the interaction of the noble metal nanoparticles with organochlorine and organophosphorous, and explores the possibility of degrading different halocarbons using noble metal nanoparticles.

The life cycle of a product is the total time between the fabrication and the disposal of the product. It involves four major stages: research stage, production stage, supply chain, and usage and disposal. The research can either be academic research in universities laboratories or industry R & D centers. Once the technology is designed and tested, the product needs to be developed and manufactured. The two key steps in this process are: procurement of raw materials and production and assembly of the unit. Procurement can be done through invitation of bids, request for proposal (RFP) and direct contracting. Production and assembly can be either a centralized or de-centralized process.

The supply stage includes the distribution and transportation of the product from the production facilities to the consumers. The main channels of distribution are through producer-wholesaler-customer, producer-wholesaler-retailer-customer, producer-direct customer, innovative approaches and marketing. Innovative approaches include distributing through NGOs and micro-financing institutions. They also involve women self help groups (SHGs) providing them employment and trying to raise their standard of living.

The last step of a product in the life cycle is use and disposal. Once the product is bought, it needs to be maintained frequently and properly to ensure that it is effectively purifying water. Recycling of the entire product or various product components is also important due to environmental benefits from generating less waste and reducing energy consumption. The author also argues that risk management should become an integral part of the culture of the

³ The magnetic nanoparticles used at IIT Bombay are Fe_3O_4 and $\gamma\text{-Fe}_2\text{O}_3$

organization involved in the production process. Some good guidelines to follow are listed below:

- A Standard Operating Procedure (SOP) for operations involving nano-materials should be strictly followed by everyone in the process.
- Researchers and workers should both have relevant safety and lab-specific training.
- Researchers and workers should use adequate personal protective gear and safety features in the laboratory.
- The storage containers and facilities need to be well-sealed and properly labeled.

In summary, these findings from the key documents covered by this literature review will feed into the design and delivery of the recommended AfriClay Deluxe product.

4. Methodology:

The methodology to achieve the defined objectives relies primarily on product benchmarking, field research, mold making documentation, and product distribution analysis. The product benchmarking focused on the study of four HWTS products in the global market. For field research, the author visited PATH in Seattle, PureEasy in Guangzhou, China, and the three largest cities in Ghana. In addition, an in-depth household survey was conducted during January 2013 in urban Ghana. A total of 40 qualitative surveys with households were conducted by the author, together with a team of two other students, one from MIT Urban Planning Department and the other from Ashesi University Computer Science Department. The survey took place in Accra, Kumasi and Tamale, the three largest cities of Ghana.

4.1 Product Benchmarking

The benchmarking analysis consists of two stages. The first stage involves problem identification and idea screening. The second stage involves detailed studies for selected products in the screening process. During the first stage, a preliminary study of the current product: AfriClay Classic Filter was done to understand the problems and potential aspects of improvement. According to Qiu, the biggest concerns about AfriClay Classic Filters are overall storage size and appearance. The product size can be either too large or too small for families of different sizes. And the physical design is not aesthetic according to as many as 26.7% respondents in Tamale.

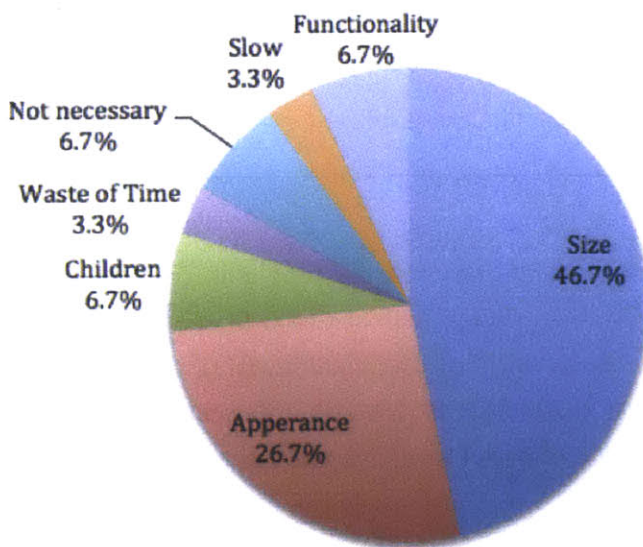

Figure 3: AfriClay Classic Filter Concerns (Qiu, 2012)

With the above information, an initial screening of products was completed to select filters with appropriate sizes and appealing designs. The goal was to eliminate designs that do not help to lead to the creation of AfriClay Deluxe Filter, and to focus on opportunities worthy of further investigation. The author reviewed a number of existing products in the global market in order to learn from potential models. These products include Super Tunsai Filter (Cambodia), C1 Common Interface Filter (China), Ecofiltro filters (Guatemala), as well as several filters from India, Brazil and Europe, etc. Of all the products reviewed, the author identified three desirable ones: Super Tunsai, C1 Common Interface and Ecofiltro, whose design features will be discussed in detail in Chapter 5. These are the three filters with most information available for further research, and are the most promising models to investigate and learn from.

Then another analysis was done to determine whether to use a plastic container or ceramic container for this high-end water filter exterior. Ceramic containers can be either produced locally from a third party or imported from China or elsewhere. The use of plastic containers most likely requires purchasing injection moldings or collaborating with local plastic manufacturers. A comparison of the options is tabulated as below.

Table 3: Comparison of plastic container and ceramic container

	Production	Transportation	Aesthetics	Breakage	Water Taste	Overall Cost	Selection
Plastic Container	OK	OK	OK	Hard to break	OK	OK	✓
Ceramic Container (locally)	Difficult	OK	OK	Easy to break	Good	High ⁴	✗
Ceramic Container (from Outside)	OK	Difficult	Good	Easy to break	Good	OK	✗

Due to production difficulty, transportation and easy breakage problems, plastic container proves to be a more viable feature for the new filter design than ceramic. With the preliminary study findings, the author travelled to Ghana in January 2013 for field research to further prove concepts and solicit feedback for potential designs, as discussed later in this chapter. The second stage of benchmarking analysis involves detailed studies for selected products, and is discussed in Chapter 5.

⁴ The author visited local pottery shops in Accra, and the average price quote was about US\$30 (GHS60) per container

4.2 Field Research

Between January 6th, 2013 and January 20th, 2013, with a sample unit of the newly developed C1 Common Interface product brought from China, the author conducted a qualitative study in rural, suburban and urban areas of Ghana, but with a particular focus on the urban area. The purpose of the survey is two folds: 1. Solicit feedback and explore middle and upper class customer's attitudes towards the C1 Common Interface Filter. 2. Expose potential customers to this new Chinese model of HWTS product. The objectives include finding out the best price for this type of water filter, and understanding whether or not this design meets Ghanaians' needs and aspirations.

The author, Shengkun Yang (MIT), was the primary interviewer and was responsible for leading the survey. The other two members of the survey team, Abel Manangi (MIT) and George Neequaye (Ashesi) were responsible for recording the information and keeping notes of the interviews.

The survey design drew largely from Vanessa Green and Weini Qiu's household survey methodologies of the past years in Ghana, and was further developed according to the objectives of this study. Each team member leveraged relevant knowledge from their professional area of expertise to ensure a well-rounded study that considered not only engineering design but also social and economic factors influencing the use of HWTS products. The locations and neighborhoods of the interviews are shown in Table 4:

Table 4: Survey neighborhoods in Ghana

	Survey neighborhoods	Study lengths	# Of interviews
Accra	East Legon, Spintex	10 days	20
Kumasi	KNUST	2 days	10
Tamale	Kapohini	3 days	10

The surveys were designed to be 30-minute qualitative interviews (in-depth interview/discussion). The data from the 40 surveys is compiled and analyzed in the Chapter 7 Results section. The survey questions are included in Appendix B.



Figure 4: Shengkun Yang conducting survey at A&C Mall, East Legon, Accra



Figure 5: George Neequaye conducting survey at a household, East Legon, Accra

5. Products Descriptions:

After the first stage of benchmarking analysis, the second stage focused on studying the three filter designs identified from the previous stage: Super Tunsai, C1 Common Interface, and Ecofiltro, in addition to PHW's AfriClay Classic Filter. This study serves as a reference to design and modify new ceramic pot water filters in Ghana.

5.1 Hydrologic and its Products: Tunsai/Super Tunsai

Hydrologic

Hydrologic is a social enterprise in Cambodia that grew out of a project of International Development Enterprise (IDE) Cambodia, and currently has 40 employees (Agster, 2012). IDE, an international NGO founded in 1982, first introduced ceramic water purifiers (CWP) to Cambodia in 2001 with assistance from Manny Hernandez and Ron Rovera of Potters for Peace in Nicaragua (PATH, 2011). Between 2001 and 2009, IDE operated the CWP business with cost recovered partially from sales and partially from grants. IDE branded the product "Tunsai", or "Rabbit" in English, an animal associated in Cambodian folktales with wisdom and cunning. After 2009, IDE spun off Hydrologic as a commercial entity, and Hydrologic began its independent production and sales (PATH 2011).

Tunsai Filter

Tunsai CWP consists of a flowerpot ceramic filter element, a container for the filtered water, a tap, and a lid. A typical filter element can hold eight liters of water, and it sits inside a 20-liter container. Users pour water into the filter element and wait for the water to seep through the filter element and into the container. After that, the filtered water in the plastic storage container is dispensed from the tap and used for various purposes, such as drinking and cooking.



Figure 6: Tunsai CWP

This CWP is originated from Guatemala's filter design in 1981 and is effective at removing microbial contaminants from water through physical/mechanical filtration⁵, adsorption and disinfection via colloidal silver⁶. The tests in Cambodia achieved a 2-6 log reduction value in protozoa (van Halem, 2006). The recipe to manufacture the Tunsai filter element includes clay, rice husk and water. The manufacturing process involves a series of procedures: pressing the mixture of materials into the filter shape, allowing it to dry, firing it in a kiln and coating it with colloidal silver. The pores left when the combustible material burns plays a major role in determining the effectiveness of the filter. Hydrologic's Tunsai filter elements are manufactured at factories in Kampong Chhnang and Prey Veng Cambodia. The plastic exterior (container, lid and tap) is produced at another facility in Cambodia, and the entire unit is assembled and packaged at the Hydrologic plant (Murray, 2011).

The major distribution channel for Tunsai filters is through local NGOs that often sold the filters at a range of prices, from full subsidy to full price at \$12.50 per unit. To date, there have been over 150,000 Tunsai filters in circulation in Cambodia (Murray, 2011). Customers have learned to fill the filters at night and have a full container of water in the morning. Though the Tunsai CWP is popular for its affordability, ease of use and health benefits, its simple appearance is a barrier to uptake and continued usage. According to Hydrologic, the Tunsai penetration was low in the decade following the introduction of the product, with an uptake rate of 3.7 percent of the sales region. The Tunsai filter container resembles a garbage bin, thus users were not willing to display it in their homes. The higher-income families are not enthusiastic about purchasing such products that are being given away for reduced cost or for free. In addition to the above social aspirational issues, Tunsai filters also posed a challenge for transportation for its large volume and fragility.

Extended User Testing

In 2008 PATH conducted studies in Cambodia to learn customer preferences and behaviors in low to middle income families. The studies indicated that many families wanted devices that are not only practical but also aesthetically appealing. Improved design and promotion would increase the product uptake rate. In 2009, a nine-month extended user testing (EUT) was conducted in the State of Andhra Pradesh, India. The EUT tested five available

⁵ Originated from Guatemala's filter design in 1981. http://www.ceramicwaterfilter.org/wp-content/uploads/elmore_et_al_ecofiltro_s_iencia_in_guatemala.pdf

⁶ Colloidal silver is a liquid suspension of microscopic silver particles that have bactericidal properties

HWTS products in 20 families in rural and semi-urban areas for six months each. The five products were Rama gravity water purifier, PureIt multistage filters, Aquasure multistage filters, Lifestraw Family purifiers, and Tunsai filters. Test results provided valuable information for PATH to understand key attributes to influence adoption, continuous and correct use of future HWTS products. The EUT study also contributed to a set of design guidelines for HWTS products and was publicly shared in 2011. In addition, the test confirmed the effectiveness of Tunsai filters that provided positive user experience and received affirmative feedback (Kols, 2008). With the evidence from the EUT, PATH partnered with Hydrologic in Cambodia, and tried to redesign and transform the Tunsai filters to realize not only the health benefits but also the aspirations of low-income consumers.

Super Tunsai Filter

According to PATH, the original goals of developing this new product were to keep the positive characteristics of Tunsai: a simple/intuitive device that effectively filter water at a reasonable amount of time, and to design an attractive exterior that's easy to ship and store. Another goal, which was defined later in the work progress, was to make the design flexible so that it fits ceramic pots of different sizes and from different countries. This goal was achieved by designing an adaptor ring that can be made with different internal diameters to accommodate pots of different sizes (Murray, 2011).

The following guidelines, adapted from PATH's publication Newly designed ceramic water pot for low-income households, are applied directly to the work of upgrading the Tunsai filter (Murray, 2011):

- Provide commercial firms and other stakeholders with credible product design information and recommendations.
- Enable more rapid development of products with aspirational value to low-income consumers, products of high quality, and products that offer the best performance for a given price.
- Promote correct and sustained use of HWTS products—especially by low-income users—by identifying and prioritizing product attributes with the greatest impact on user behaviors.
- Increase innovation, quality, and consumer choice in HWTS products.
- Catalyze discussion of product design approaches and the value of developing performance and design standards at the national and international levels.

The guidelines include the following indicators that were taken into account in the Tunsai upgrade⁷:

Key indicators for product aesthetics

- Consumers find products visually appealing and appropriate for their sociocultural use environment (often based on prior experience with the aesthetics of other products).
- Product aesthetics contribute to long-term pride of ownership among users.

Key indicators for fitting into the household

- Product does not require a connection to electricity or piped water.
- Device can be set up, operated, and maintained without the need for tools, written instructions, or outside assistance.
- Device can be located anywhere in the house.
- No water is spilled when filling, operating, or dispensing water from the device.

Key indicators for product format

- Products employing a free-standing tabletop format are observed to offer the best combination of user accessibility, adequate head height, and minimal footprint. The freestanding tabletop format provides the greatest flexibility for placement in diverse use environments.

⁷ Adapted from *Newly designed ceramic water pot for low-income households*, Marge Murray, PATH, 2011

Figure 7 below shows the design research loop of the partners involved in developing and distributing the Super Tunsai Filter.

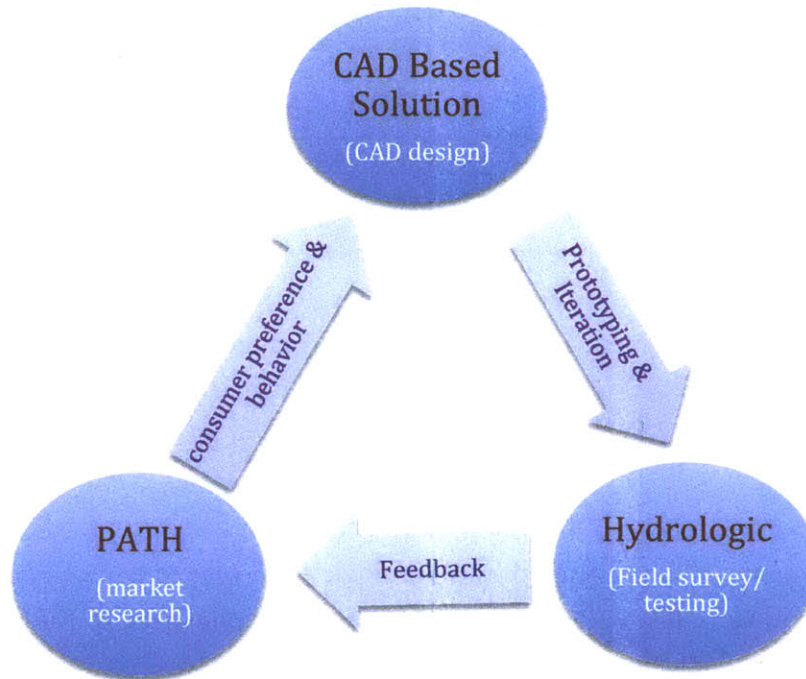

Figure 7: Super Tunsai Design Team

Closely following the guidelines, Hydrologic worked with the Seattle firm CAD-Based Solutions to redesign the exterior part of the Tunsai filter. In development for over a year, the more aesthetic Super Tunsai was successfully redesigned to align with Cambodian customer preferences. Super Tunsai, launched in 2011, utilizes the same filter element mechanism to purify water, but is more attractive and easier to transport and store.

For the Super Tunsai product, PATH had the injection molds manufactured in China for about \$50,000, and shipped to Cambodia for about \$500. The supplier in Cambodia took the Chinese molds, but while the molds were fine, the Cambodian manufacturers produced inferior plastic products. So the molds were later shipped to Vietnam where consistently good plastic products were manufactured and shipped back to Cambodia. Production cost of Super Tunsai is

about \$17/unit⁸. The sales price, sales number, production cost and molding cost are tabulated as below:

Table 5: Super Tunsai Price Information

	Molding cost (\$)	Production cost (\$)	Retail price (\$)	Sales volume June to September 2011	Sales till Jan. 2012
Super Tunsai	~50,000	~17	22	2,536 (microfinance)	4,394

The biggest challenge PATH and Hydrologic faced has been to find the right sales person to help the product penetrate into the market. They completed a pilot project in Cambodia in 2012, utilizing microfinance to promote the sales of Super Tunsai. The results showed an increase uptake from 6 percent to 43 percent among microfinance institution clients, over 80 percent continuous use and 100 percent loan repayment (Abt Associates, Inc, 2012). The measurement also showed that 21 percent of the population in the pilot area had purchased the new product.

The revenue and cost incurred by Hydrologic from June to September 2011 in the direct sales with microfinance institutions (MFI) sales model is summarized in Table 7 (Abt Associates, Inc, 2012). The data indicates that 93.5% of Hydrologic’s cost was recovered from the MFI sales model.

Table 6: Hydrologic's Revenues and Costs in MFI Sales Model

Total Sales Units-Tunsai	20
Total Sales Units-Super Tunsai	2536
Total Revenue	\$54,359
Expenses	
Value Added Tax (VAT)	(\$5,436)
Product Cost	(\$33,547)
Direct Sales Exp	(\$1,230)
Administrative Expenses	(\$17,912)
Total Expenses	(\$58,125)
Net Margin	(\$3,766)

⁸ Pat Lennon confirmed that this is the correct product cost of the Super Tunsai, as best as he knows it, but he also indicated that Hydrologic wasn’t always telling PATH full disclosure about its costs, so he wasn’t absolutely certain of that number

A comparison of Tunsai versus Super Tunsai is shown below:



Figure 8: Tunsai and Super Tunsai

Table 7: Comparison of Tunsai and Super Tunsai (Murray, 2011).

	Tunsai		Super Tunsai	
Component	Overall design	Details	Overall design	Details
Lid	Cylindrical shape-wall is 90° angle to top surface	Accommodates small range of pot rim heights	Tapered from rim to center	Accommodates large range of pot rim heights
Plastic container	One unit that holds the filter and receives water, 18L capacity	Transparent, no color, with ceramic pot clearly visible. Garbage bin appearance	Two units that nest: pot holder + clean water receptacle, at a capacity of 9.5L and 10L respectively	Transparent, blue, tapered shape. Clean water receptacle fits into pot holder, easy for shipping and storage
Ceramic pot	0.2 micron pores, colloidal silver coating	Reddish-brown color	Same as Tunsai	Same as Tunsai
Tap	Conventional turn tap	Turn handle to dispense + shut off	Conventional push tap	Press handle to dispense + shut off
Adaptor ring	None	N/A	Plastic ring supporting ceramic pot	Of different internal diameters to accommodate ceramic pots of different sizes
Stand	None	N/A	White plastic, providing underneath clearance for cups	Cue to refill is when water level in receptacle is at top of stand

5.2 C1 Common Interface

The C1 Common Interface is a design specification for interchangeable filter element usage at a common connection point between unfiltered and filtered water receptacles. Development of such products is a collective effort of PATH, Cascade Design, Inc and three Chinese companies that manufactured the C1 Common Interface products. PATH's goals were to produce effective and appealing products for emerging markets, and provide commercial enterprises the opportunity to continue to produce, distribute and sell them when the PATH Safe Water Project finished in November 2012.

According to PATH, the C1 Common Interface provides options for both customers and brands. Since the filter elements are portable and replaceable, customers can select the best available filter elements for their application without having to replace the entire filter system. Water filter brands can also take advantage of more sourcing and technology options because they can more easily partner with filter element producers to reach customers.

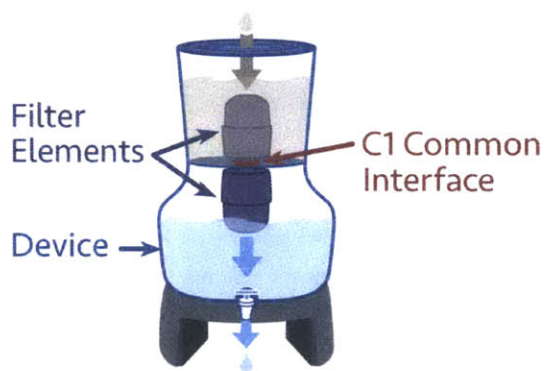

Figure 9: C1 Common Interface (PATH, 2012)

C1 Common Interface design has the following features:

- Intuitive filter system that builds end-user confidence, and ensures proper and safe assembly.
- Rubber washer prevents leak through untreated water around filter elements during use and during filter replacement.
- Upper-chamber height supports adequate flow rates.
- Design allows attachment of up to two filter elements (upper/lower).
- Nonproprietary interface allows for interchangeable parts.
- Durability is improved over existing ¼"-diameter ceramic fitting⁹.

⁹ Adapted from PATH's Guide to New Water Filters with C1 Common Interface

PATH provides a standard, no-cost license for the C1 Common Interface design. If interested, an email with “C1 Common Interface license inquiry” in the subject line should be sent to newwaterfilters@path.org¹⁰. Terms of the standard license are nonnegotiable since the grant funding for this effort expired November 2012. After this date there was no funded staff time available to support agreements negotiation. The relevant engineering files will be provided to all licensees.

PATH visit

With his thesis advisor’s introduction, the author visited PATH in Seattle on October 9th, 2012. Pat Lennon, a representative of PATH’s Safe Water Project, showed the author various types of filters in the PATH lab, including the C1 Common Interface filters that would be launched shortly. The production cost of each unit is about \$12 in China (PATH, 2012).



Figure 10 Chinese Filters in PATH lab in Seattle

The filter on the left side of Figure 31 with a clear plastic container was made of Styrene Acrylonitrile (SAN) plastic. This plastic is usually low cost and food-safe but brittle (in mechanical behavior) for transportation. SAN offers good optical transparency, clarity, and high-

¹⁰ PATH planned to publish instructions and a copy of the standard license on its website at <http://sites.path.org/water/hwts/technology/new-water-filters-resources/> by December 2012.

gloss finish. In comparison, polypropylene plastic (center and right of Figure 31) is typically less expensive than SAN and offers increased durability and toughness. The polypropylene material is recommended for a better durability and price, whereas SAN material device is recommended for better optical clarity, surface finish and gloss. For most emerging-market settings, the polypropylene material is recommended by PATH over SAN because of the increased durability.

Pat has provided the author and through him, PHW with the Super Tunsai CAD designs, as well as product descriptions, guidelines, and manufacturers (but not the designs) for the new Chinese products¹¹. The three Chinese manufacturers PATH worked with, selected from 60 possible manufacturers, are in Ningbo (east) and Guangzhou (south). If PHW selects the two manufacturers in Ningbo, they would put “Pure Home Water” label on the product. If PHW selects the company in Guangzhou, run by university professors, they would brand their own product.



Figure 11: C1 Common Interface Filters from China

The three C1 Common Interface filter systems (in Figure 11) share a common interface. There are three different ceramic filter elements in these devices:

1. Mineral pot-type filter
2. Ceramic disk filter
3. Traditional candle filter but side-mounted in order to have more pressure head above the filter.

A qualified, third party US lab did performance testing. Field-testing was of user

¹¹ PATH couldn't underwrite the cost of injection molds for PHW since their focus has shifted from the Safe Water Project to sanitation.

feedback, not of product performance. These filters were tested based on National Sanitation Foundation (NSF) Type 1 and Type 3 water¹². No protozoa test was done due to budgeting constraint. The C1 Common Interface Systems were designed for the Asia market. Therefore, they might not be well suited for the Africa market. Asian users, for example, in India, wanted modern looking product, which nonetheless retain traditional elements¹³.

PureEasy visit

Of the three companies manufacturing the C1 Common Interface Filters, the one located in Guangzhou is named PureEasy Hi-Tech Co., Ltd. The author made a trip to the company on Dec.24th, 2012. Founded by two professors (husband and wife) from South China University of Technology, PureEasy specializes in outdoor/portable water treatment and household water purification. The husband, Dr. Sui, a mechanical engineering professor designed the kiln and molds for the filter element. The wife, Dr. Huang, an environmental engineering professor designed the nano-metal clusters media (NMC) to further treat residual chlorine, heavy metal, and pathogens (Figure 12). The dual ceramic membrane cartridge and NMC are the two key technologies from PureEasy.



Figure 12: PureEasy Filter and Filter Element

¹² Type 1 and Type 3 water are defined by [US EPA P231](#).

¹³ One user hid their filter from their neighbors... didn't want to be appearing to have a highly modern look (because it was beyond their caste)



Figure 13: NMC

The dual ceramic membrane cartridge, made of diatomite (also known as diatomaceous earth), is a point of use ceramic filter element and contains two layers of ceramic membranes. According to Dr. Huang, their dual ceramic membrane cartridge can filter out particles down to 0.1 μm , and the pore size is in the range of 0.1~0.5 μm with the average of 0.2 μm . This membrane cartridge is said to achieve a removal efficiency of 99.9999% and eliminate the risk of recontamination due to the dual ceramic membrane.

According to Dr. Huang, NMC is a novel of water purification media made from millions of nano-metal clusters on porous inorganic material. Formed in innumerable micro primary cells, NMC has a very strong redox ability to reduce heavy metal ions such as Pb^{2+} , Cd^{2+} , Cr^{6+} , and As^{3+} , and turn them into insoluble metal. Organics in water are oxidized into harmless components. The growth of bacteria and viruses are inhibited due to the shift of oxidation/reduction potential. Compared to activated carbon, NMC is a more effective water purification media.

Dr. Huang claimed that their efficient manufacturing process and excellent workmanship have made PureEasy's products more effective than its competitor such as Dukang, another company recommended by PATH. The biggest challenge in product development that PureEasy faced was the chaos in the domestic market. Although patented, their products have not received enough protection against counterfeits in China. There have been companies who copied PureEasy's purification technique, not as effectively though, applied for the same patent, and began producing and disseminating the counterfeit in the market.

There are two filter elements produced by PureEasy that are compatible with the C1 Common Interface design. One is a "sideways" – style ceramic filter element, the other is a "pancake" style ceramic filter element. Pictures and product features are provided below:

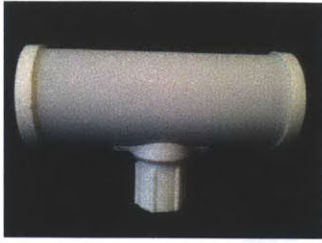

Figure 14: Sideway Style (PureEasy)



Figure 15: Pancake Style (PureEasy)

Table 8: Sideway vs Pancake filter elements (PureEasy)

	Sideway	Pancake
Flow rate	>40 ml/min	>40 ml/min
Capacity	2000~3000L	2000~3000L
Unit price	\$2.8	\$2.4
Weight	140 grams	240 grams
Silver coated	Yes	Yes

5.3 AfriClay Classic Ceramic Pot Filter



Figure 16: AfriClay Classic Filter + Filter Mechanism + Hemispherical-shaped Clay Pot Filter Element

Technology

Brief description of the technology, including supplies needed

The AfriClay filter is a ceramic pot filter manufactured in Ghana. In this thesis and henceforward, we will refer to it as the AfriClay Classic, in order to distinguish from the intended new product, the AfriClay Deluxe, the design and development of which is the investigation of this thesis. The filter unit consists of a fired hemispherical shaped clay pot filter element, a filtered water receptacle (plastic bucket), a tap and a coverlid. The other supply needed is a brush used for cleaning the filter element. Pure Home Water produces these filters at its factory in Tamale, Ghana and sells the AfriClay Classic filter with a laminated pictorial instruction sheet shown on Figure 16 and a brush.

The volume of the hemispheric-pot filter is 10 liters. These filters are made from a mixture of red clay, grey clay, and rice-husk, which gets pressed in a hydraulic press and fired in a kiln. The grey clay is called Wayamba, red clay is called Gbalabi, both of which are local clays and named after the villages they come from. The surfaces inside and out are treated with 1 cc of 3.2% colloidal silver in 300ml of water.

The filter element sits directly atop a food grade high-density polyethylene (HDPE) plastic storage receptacle with a total volume of 40 liters and a water storage volume below the

filter element of approximately 30 liters. The filter element and storage receptacle are then covered by an HDPE lid. The storage receptacles and lids are made in Ghana.



Figure 17: AfriClay Classic Filter with Lid, and Tap

The storage receptacle is fitted at the bottom with a spring-loaded plastic tap to allow filtered water to be dispensed from the storage receptacle for use. The taps are sourced outside Ghana from one of several suppliers.

What contaminants does it remove?

Water quality tests conducted in households in the village of Yipelugu in January 2013 assessed the effectiveness of the AfriClay Classic filters in households. Results for bacterial tests and for turbidity are summarized below in Table 9. The percent removals are for paired samples from households with filters.

Table 9: Geometric means of total coliform, E. coli, and turbidity (Cheng, 2013)

Water Quality Parameter	Stored Sample	Filtered Sample
Total coliform (MPN/ 100 mL)	12,905 (9,162-18,197)	141 (78.7-253.5)
95% Confidence interval	(N = 81)	(N = 83)
E. coli (MPN/100 mL)	202 (133-308)	4 (3-5)
95% Confidence interval	(N = 76)	(N = 85)
Turbidity (NTU)	157 (122-201)	40 (31-51)
95% Confidence interval	(N = 85)	(N = 85)
% Total coliform reductions^a	--	99
% E. coli reductions^a	--	98
% NTU reductions^a	--	80

^a Calculated as $\log_{10} \text{reduction} = \log_{10} \text{influent} - \log_{10} \text{effluent}$ and subsequently the \log_{10} reductions were transformed into percentages.

How does it remove contaminants?

Particles, bacteria, guinea worm, cyclops and protozoa are removed by physical straining, and also adsorption by chemical and biological mechanism. For the physical straining process, the combustible organic materials of the filter element create pores of size ranging from 1 to 100 micron, which removes some contaminants through size exclusion. For adsorption where particles bind to a surface, the binding could be weak and reversible. Compounds with color and those that have taste or odor tend to bind strongly (Bugli, 2000)¹⁴. The filter element is coated with colloidal silver and/or silver metals that may act as a bactericide and viricide.

Capacity (flow or volume)

Each filter is individually tested at the Pure Home Water factory to meet a flow rate between 2 to 7 liters/hour. If a filter does not meet this flow rate requirement at the time of production, it is rejected in the quality control process and destroyed. As a filter element is fouled, the flow rate diminishes, but flow rate is recovered upon cleaning of the filter with the brush that is produced.

Replacement period

The filter element should be replaced every three years. Replacement is indicated by a reduction in the recovery rate of filtration upon cleaning, or upon breakage of the filter element. The plastic buckets have a life of 10 years or more. The tap is highly durable, but if necessary, can be replaced due to breakage or fatigue failure.

Cost of technology per unit

Capital: US\$25.00 (GHS 50) including filter and appurtenances

O&M: US\$4 (GHS 8) for filter element replacement, US\$2 (GH¢4) for tap replacement¹⁵

Operation and Maintenance

1. Settle turbid water in a storage vessel before filling the ceramic pot.

¹⁴ <http://www.afssociety.org/filtration-media/hydrocarbon-evaporative-emissions-control-for-automotives>

¹⁵ **Exchange Rate:** US\$1.00 = GHS2.00 (May 22, 2013)

2. Fill filters to the top regularly to improve filtration rate. Typically users fill the filters in the morning and in the evening.
3. Clean filter with brush provided when flow rate becomes too slow.
4. Clean storage unit with soap and filtered water. Disinfect with chlorine bleach, iodine or boiled, cooled water after cleaning.

Advantages

- Easy to use.
- Water tastes good.
- Keeps water fresh.
- The ceramic filter element helps keep the water cool.
- Ceramic pots are culturally acceptable, as clay pots are traditionally used for water storage.
- Locally produced.
- Clarifies turbid water and makes it look clear and clean.
- Water is collected directly from storage receptacle for use hence it is safely stored in a safe storage receptacle.
- Equipped with a tap to prevent recontamination.
- Ceramic pore structure filters out 99% of bacteria.
- Colloidal silver in the pores inhibits the growth of biofilms.
- One-time purchase provides 3 to 5 years of drinking water for a household.
- Can be used year round and at all times of day.

Disadvantages

- Highly turbid water can reduce the flow rate to unacceptable levels.
- Filter element is fragile and easily broken.
- Spigots from some manufacturers are subject to fatigue failure.
- Requires regular maintenance.
- Fuel required for filter element production.
- Filter must be replaced over time.

Organization's Name and Contact Info

Name: Pure Home Water-Ghana

Contact Person: Mary Kay Jackson, Managing Director
Address: PO Box LG 824
Legon, Accra, Ghana
Telephone(s): 0246-560145
Email: marykay.jackson@yahoo.com

Measurements of the Qualiplast bucket and the AfriClay Ceramic Pot Filter Element

Qualiplast (new AfriClay bucket)

Inner diameter of ring lid = 11 5/8"
Outer diameter of ring and lid = 16"
Inner diameter of the top of the bucket = 14 5/8"
Outer diameter of the top of the bucket = 15 7/8"
Height = 20"

Filter element

Volume = 10L, measured 0.5" below the top of the rim
Volume = 9L, measure 1" below the top of the rim

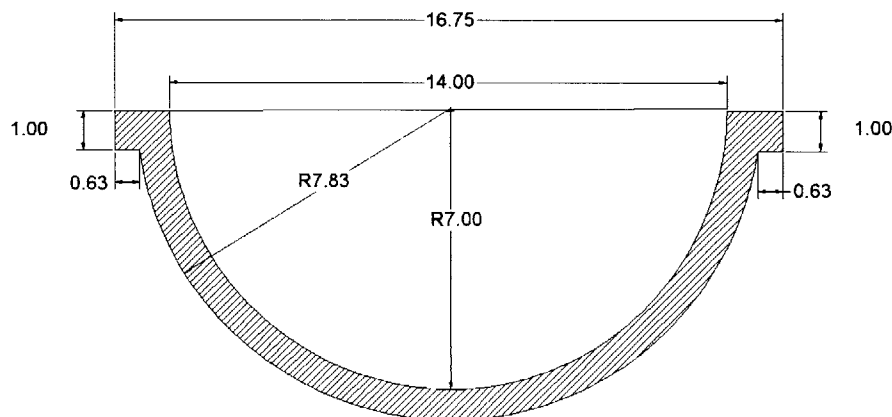

Figure 18: AfriClay Classic Filter Element Dimensions (in inches)

5.4 Ecofiltro

Ecofiltro is a social enterprise in Guatemala, producing ceramic pot water filters. The technology behind Ecofiltro is the same as that of PHW, Hydrologic and other ceramic pot filter factories. The Ecofiltro filter is composed of clay, sawdust and colloidal silver, with all the material locally sourced.

The market for Ecofiltro includes both nonprofit and for profit consumers. The nonprofit consumers are mostly rural population where there is a lack of access to safe drinking water and water borne disease is the leading cause of children death. Ecofiltro serves the rural market by providing filters to NGO's such as World Vision, Mercy Corps, Save the Children, Plan International, etc. According to Ecofiltro, they work closely with community leaders in each village to ensure the sustainability of the program. Additionally, an Ecofiltro trained teacher provides a health and hygiene course to the community while delivering the filters.

The for-profit market is in the urban area where households purchase and drink bottled water at a high price. Ecofiltro filters are priced at \$44 and above (Murcott, Ecofiltro Product Models, Prices, and Sizes, 2010), and are distributed through a door-to-door delivery for this population. The drinking water cost is substantially reduced through filters as opposed to bottled water. The revenue generated from the urban area cross subsidizes the fixed cost of the rural area, keeping Ecofiltro a financially sustainable business.

Ecofiltro utilizes a strategy called "relationship selling" in which they hire women entrepreneurs to sell filters in their villages because the buyers trust their neighbors to have common interest as them (Ecofiltro, 2011). The business has developed a network of rural women entrepreneurs to sell and distribute filters. So far, Ecofiltro has reached 34 communities in Guatemala with 2498 ceramic water filters, improving 14,000 human health. This also creates income for entrepreneurs who are largely single mothers and sole providers. In some distribution locations, Ecofiltro donates the first filter for free, signs a usage contract with customers, and charge for replacement fee every year. This model has proven to be successful and Ecofiltro encourages social enterprises to replicate the model in other countries in need of clean drinking water.



Figure 19: Ecofiltro ceramic pot water filters. Photo credit: Ecofiltro

The clay pots are created with a manual hydraulic press and air dried for up to three weeks before firing with propane gas at a cost of \$0.44 per liter in the kiln. The firing length is 8 hours with a maximum temperature of 755°C, and then being cooled overnight. The flow rates of the filters passing the quality control test is between 1~2 L/hour (Elmore, Moluf, Wilson, & Arevalo, 2009). And about 70% of the filters pass this quality control test (70% yield rate). Ecofiltro uses both plastic and ceramic containers for its filters. The second filter from the right in Figure 19 is of ceramic container, and the other three are of plastic containers. As discussed earlier in this thesis, plastic container serves as a more viable component for the new filter design.

The firing slope is as follows:

- First hour: 60°C
- 1~4 hours: 350°C
- 4~8 hours: 755°C

6. Concrete Molding Making Process

This chapter documents PHW's concrete mold-making process for a hemisphere pot filter. There are estimated to be more than 50 ceramic pot filter factories in more than 30 countries. The vast majority of factories use molds made of spun metal or aluminum. We know of one instance, Thirst Aid in Myanmar, where an early first-stage mold was made of teak wood.

PHW's molds are hemispherical and made of cement, sand and water. The history of the innovation of ceramic pot filter shape is as follows: Manny Hernandez came up with the idea of cone-shaped filters, which influenced Curt Bradner first to produce cone-shaped filters, and then to innovate to hemispherical filters. Both Manny and Curt advised PHW on the filter element manufacturing. After experimenting with both shapes, PHW decided to move forward with the hemispherical shape. When installed on the Mani press¹⁶, the female mold (FM) is above and the male mold (MM) is below (Figure 20). Compared to flower pot-shaped filter elements, these filter elements can only rest on their rims instead of their base. After the molds are produced, mold release is required to prevent the filter mixture from sticking to the molds. Plastic bags are popular as a typical aid for mold release as they can be used with any type of mold material.

The ceramic filter element shape is designed to fit into a plastic container or ceramic safe storage container. The diameter of that outer container determines the size of the filter. Thus the size of the system is determined by the designer and by the available plastic/ceramic container.



Figure 20: Pure Home Water's 1st Mani Press showing FM and MM

¹⁶ The ceramic pot filter press is named after one of the lead innovators of these filters, Prof. Manny Hernandez

List of abbreviations used in this section:

- FM: Female Mold
- MM: Male Mold
- Mani Press: MP

Tools and materials:

The following tools and materials are essential for the mold-making process. Have them ready before you begin. These materials are standard items and are available in urban markets around the world, including the markets of Tamale, Ghana where the PHW factory is located.

Items needed to make Concrete Molds

1. Sheet metal cone (specification included in Appendix E),



Figure 21: Sheet Metal Cone

2. Wooden Template A (used to hold and center the mounting bolts for the MM during the casting process. The dimensions are based on designer's filter element choice, the AutoCAD drawing of PHW's Wooden Template A is included in Appendix F),

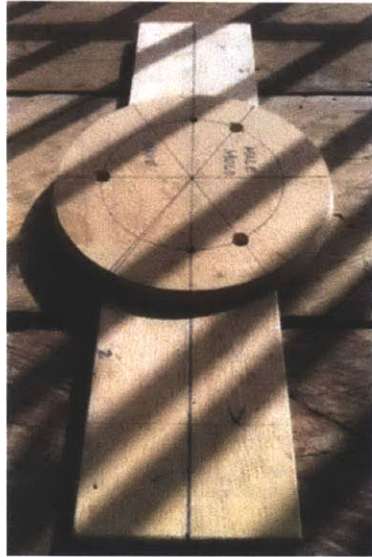

Figure 22: Wooden Template A

3. Wooden Template B (dimensions based on designer's filter element choice. The AutoCAD drawing for PHW's Wooden Template B is included in Appendix F),

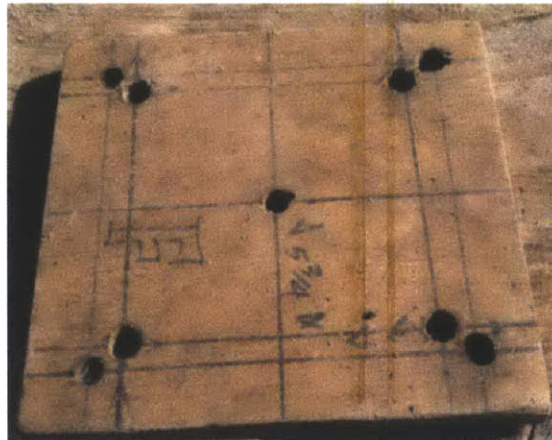

Figure 23: Wooden Template B

4. Item A (Its radius is 7", and it forms the inner diameter of the filter)



Figure 24: Item A

5. Item B (This is a wooden jig used to form the clay over Item A. The clay is used to make the FM. Item B forms the outer diameter of the filter plus the rim).



Figure 25: Item B

- Item C (Item C is made from thin, foldable metal, in this case aluminum flashing).

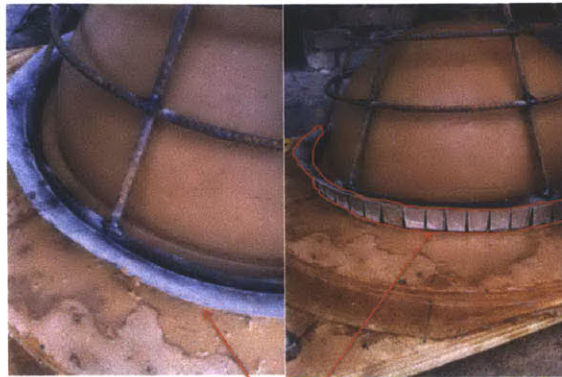

Item C

Figure 26: Item C

- Male Mold Cavity (Dimensions based on designer's choice. Drawing for PHW's case is included in Appendix F)

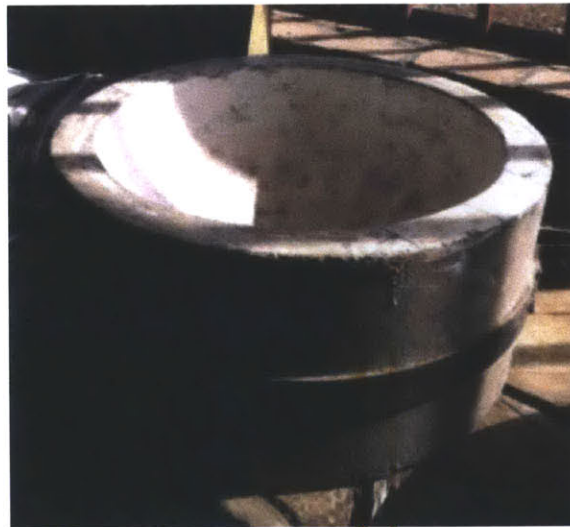

Figure 27: Male Mold Cavity

8. Trapezoidal template (TT)

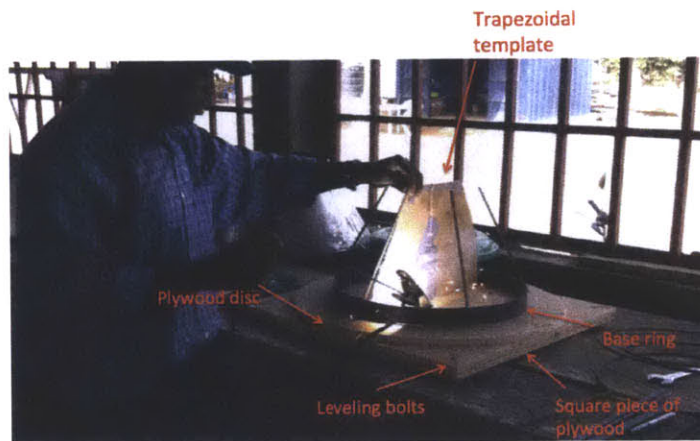

Figure 28: Trapezoidal Template

9. C Channel



C Channel

Figure 29: C Channel

10. Wooden shims (These are slivers of wood used to level a particular item. However we rely on the leveling bolts on the corners of the square plywood disk. Shims can be used under the bolts if needed).
11. Wooden dowel.
12. 1/2" diameter threaded rod.
13. Four 1/2" diameter nuts.

14. Steel wire (Same gauge wire that is used to tie rebar together).
15. Cement & sieved river sand.
16. Spirit level.
17. Welding machine.
18. Hammer.

The concrete mold-making process is divided into five major parts:

- 1) Making the Cage.
- 2) Making the filter element prototype.
- 3) Casting the female mold.
- 4) Casting the male mold.

Each part is comprised of a number of steps. Below we label each part and describe and illustrate each step.

Part 1: Making the Cage:

Description: metal cage is used to reinforce the concrete female mold

1. Begin by making the metal base ring, which is made of flat stock. Flat stock can only be purchased for the entire length of 19 feet in Ghana. It comes in different widths and thicknesses. In our case, 1 ½" wide and 3/32" thick flat stock is used. The diameter of the base ring is 16.75".
2. Also begin by making a plywood disk of 24" in diameter (Figure 31 next page). The disk is divided into 6 sections, each section at 60°, and marked on the disk with a marker. The disk is to ensure a level base on the workbench. The plywood disk is centered and secured to a square piece of plywood (See Figure 3 next page). There is a bolt attached to each corner of the square piece of plywood and these bolts are used to level the total unit on the workbench which is assumed to be not level.
3. Then continue to make the trapezoidal template (TT). Dimensions of the trapezoid are shown Figure 21. TT is made of either ¼" plywood or sheet metal.

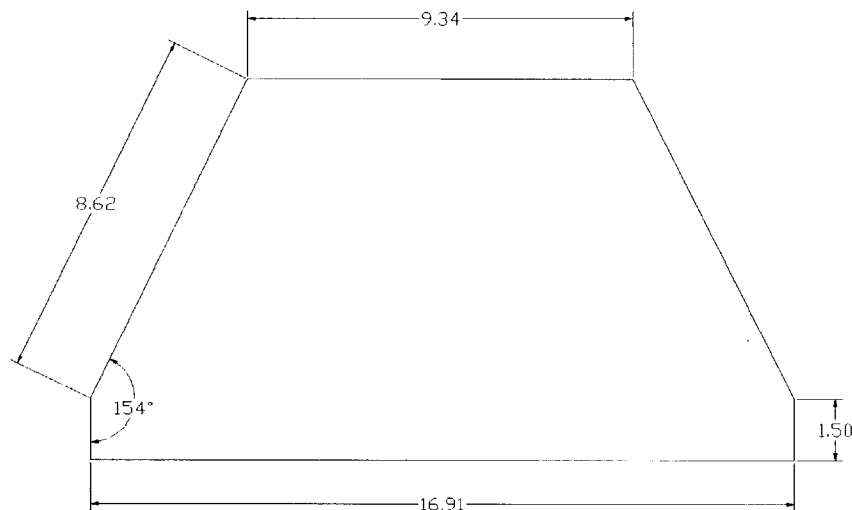

Figure 30: TT Dimensions (in inches)

4. Cut 6 identical steel rods at 10". These rods are to be the vertical portion of the cage. Have the base ring and TT ready for us.
5. Place the base ring on the plywood disk. Use the leveling bolts provided on the corners of the plywood table for leveling the base ring.
6. Place the TT inside the steel ring, weld one steel rod from Step 4 to the steel ring along the lateral side of the TT (this ensures the bar is welded at the correct angle)

7. Rotate the TT about 60° (the plywood disk is divided into 6 sections, each section at 60°), and weld another steel rod from step 4 along the lateral side of the TT.
8. Repeat step 7 for the remaining 4 steel rods.
9. Cut 3 steel rods of length 46'', 38'', and 30''
Note: These measurements were derived by measuring the diameter of each circle and multiplying by π .
10. Cold forge¹⁷ each metal rod using a metal "C" channel as an anvil to form each length of metal wire into a circle; 2 pieces of angle iron were welded together to make a "C" channel.



Figure 31: Welding steel rod to the base ring



Figure 32: Making the steel rings

¹⁷ Forging is a manufacturing process involving the shaping of metal using localized compressive force

11. Level the base ring to the plywood disk. Take the smallest of the 3 metal rings and weld it to the top of the 6 metal rods welded to the base ring.
12. Repeat with the remaining 2 rings. Use the spirit level to make sure all the rings are level with the base ring.
13. By now, the cage should look like in Figure 33, which has the flat metal base ring and 3 horizontal metal rings at 5" interval.
14. Cut one steel rod at 9", another two at 5".
15. Weld both sides of the 9" rod onto the top ring.
16. Weld one side of a 5" rod onto the ring, and the other side onto the 9" rod; repeat for the other 5" bar.
17. Have 4 threaded rods of ½" diameter and 5" length, and 8 nuts of ½" diameter ready.



Figure 33: Metal cage, not yet finished



Figure 34: Metal cage, with threaded rods

18. Weld the 4 threaded rods onto the steel rod at the top of the cage; screw the nuts all the way down until they touch the steel rods.
19. All 4 nuts should be level with the base ring, which is done by putting the spirit level on top of Wooden Template B used for spacing the bolts. Wooden Template B (see Figure 23) should be resting on top of the nuts. Place the spirit level on top of Wooden Template B and move the nuts up or down until Wooden Template B is level. You will have to set the level in 2 directions at right angle to each other to get Wooden Template B level. Wooden Template B also holds the threaded rod to the correct spacing so that everything will align to the mounting holes on the MP
20. Leave the rod 4" above the nuts. The 4 threaded rods will be used for mounting the female mold (FM) to the Mani Press (MP).
21. Now the metal cage is finished. The final product should look like in Figure 35.



Figure 35: Finished metal cage

Part 2: Making the filter element prototype

Description: The filter element is the ceramic pot itself, which filters water to make it safe to drink. The filter element prototype will be used to make the FM in Part 3.

A special tool is made for this step. It is a wooden dowel (with the diameter of a broom handle) with a nail in it. The nail is stuck out of the end of the dowel, to be the same thickness as that of the filter that is 0.75". This tool is poked into the clay. If the dowel poked made its print in the clay, it means the clay is too thick at that spot. Clay is removed by scraping it away with one's fingers then smoothed out. If the dowel does not make an imprint, it is too thin and clay should be added.

1. PHW has several types of local clays available when making the filters, of which there are two common types – Gbalahi and Wayamba. Prepare 5lb of dry Wayamba Clay powder, and mix it thoroughly with water. Wayamba clay is used since it shrinks less than the Gbalahi clay.
2. Place Item A onto the plywood disk, and level the plywood disk by adjusting the leveling bolts at the corner of the disk.
3. Apply the wet clay onto Item A, as in Figure 36 (Water was applied to the outside surface of the clay for lubrication which made it easier to turn the jig, i.e. Item B)
4. Place Item B onto Item A with clay applied; rotate Item B to remove excess clay on Item A and to make the shape of the filter element. The space between Item A and Item B is exactly the shape of a filter element.

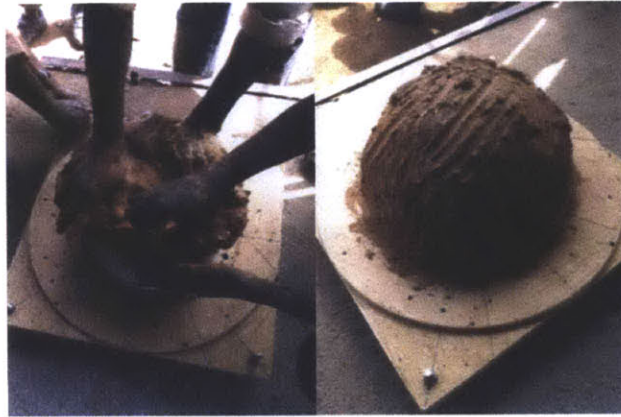

Figure 36: Preparing and applying clay onto the Item A

5. Repeat Step 3, and rotate until the clay forms the outside shape of the filter element. Apply water and extra clay as needed at this step, as in Figure 37. A little portion of the clay needs to be saved for later steps.



Figure 37: Rotating Item B to make the shape of the prototype filter element

6. When the prototype is finished, let it dry until leather hard before placing it under the metal cage and pouring the cement. The prototype can be placed in the sun to hasten the drying process but it must be rotated and checked on occasionally or it will shrink and crack. As soon as it is leather hard, it can be brought in out of the sun.

7. The finished prototype filter element should look like in Figure 38.

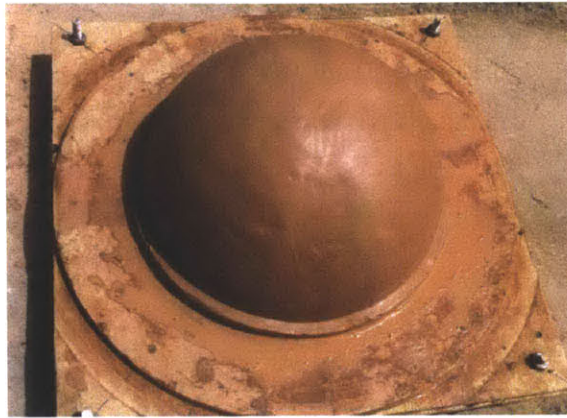

Figure 38: Finished prototype filter element

Part 3: Casting the Female Mold

1. Prepare 3 parts fine sand, 1 part cement and $\frac{1}{2}$ part water. Do not add all the water at once. Keep adding water until the right mix is arrived at. Mix thoroughly before pouring.
2. Apply Vaseline around the exterior of the prototype.
3. Place the metal cage over the prototype produced from Part 2. Make sure the prototype is at the center of the metal cage.
4. Place Item C around the base steel ring, as in Figure 39.



Figure 39: Metal cage over prototype; Item C around base of steel ring

Item C is made from thin, foldable metal, in this case aluminum flashing. Its purpose here is to contain the cement against the metal base ring and keep the cement from pouring out the bottom.

5. Apply Vaseline to the interior of the metal cone
6. Fit the metal cone around the cage making sure that it is tight up against Item C. Fit the plywood wooden disk, with the hole in the center, over the cone making sure that it is level. Tie wires from this disk to the wooden base beneath the FM. This will secure the cone firmly down so that the cement is retained inside the cone (Figure 40).

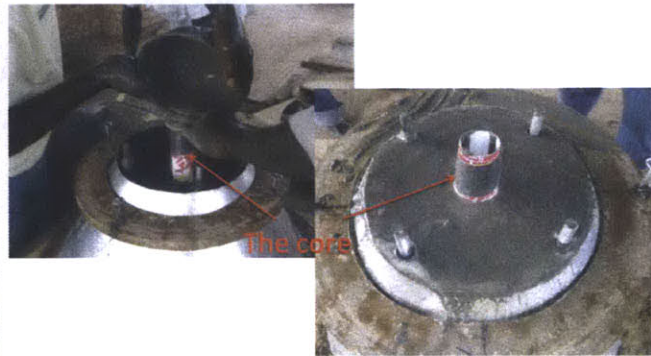

Figure 40: Metal cone around the cage, and secured with wires **Figure 41: Pouring concrete**

7. Set a cylindrical core of 2" in diameter at the crowned top of the mold to create a hole at the top of the FM after casting. The core is fashioned from a piece of pliable cardboard that is formed into a cylinder shape and duct taped together. Cardboard from a cereal box can be used. It should be noted that the core is placed so that the larger opening is inside the mold and the smaller opening on top of the mold. The reason for this is that when the hole is filled with cement after it has been cast and allowed to harden, the cone will not be pushed out during the filter pressing process.
8. Pour concrete prepared in Step 1 into the metal cone, and to the level right above the nuts, (Figure 41). All 4 nuts should be level with the base of the bottom ring. This procedure was accomplished when the threaded rods are welded to the cage (Step 1-13). This ensures that the FM mold will be level with its mounting bracket located on the MP, and also level with the MM moveable-mounting platform.
9. Set it aside and let the concrete cure for 24 hours out of direct sunshine. The casting can be undone the next day.
10. Untighten the wires; remove the metal cone and the core. After dismantling, the FM should be water cured. It should be left submerged in a water tank for about 3 days.
11. Remove the core at the top of the mold, and using a hardwood dowel and hammer, proceed to remove Item A and clay from the FM. This is done by inserting the dowel

into the hole left by the core and hammering the dowel until the MM is released. The FM should be laid on its side for this step.

12. After the MM is released with the clay, thoroughly clean up the inside of the FM. Fill up any air bubble holes that have occurred on the inside and outside of the FM holes with body putty. After this is accomplished the hole at the top of the FM can be filled in with cement.
13. The finished product should look as in Figure 42, except that the hole should be filled with auto body putty.



Figure 42: Finished Female Mold, except that the hole is unfilled

A cross sectional view of the clay filter prototype inside the metal cage, covered with the sheet metal cone is shown below. A same picture with dimensions is included in Appendix D.

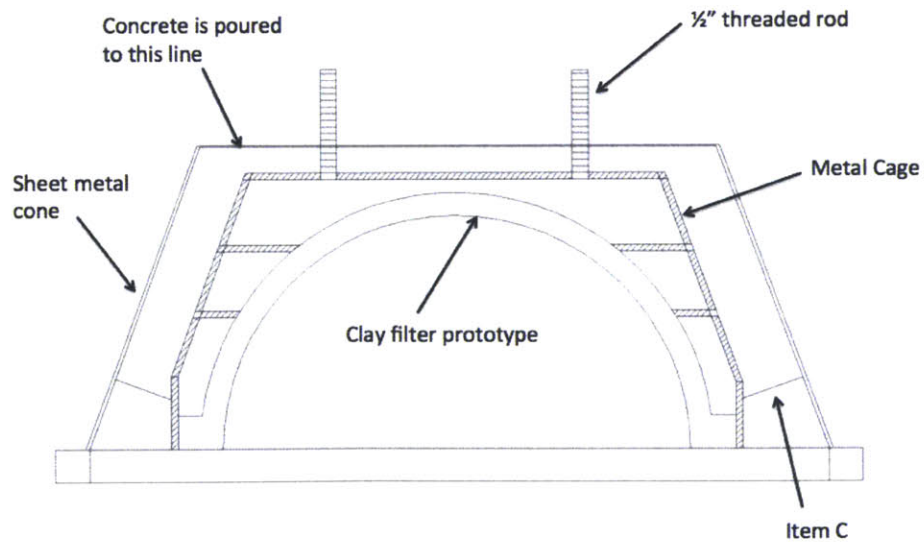

Figure 43: FM Making Cross Sectional View

Part 4: Casting the Male Mold

1. Prepare 3 parts fine sand, 1 part cement and $\frac{1}{2}$ part water. Mix thoroughly.
2. Cut 3 steel rods at 6" in length, and weld them on the underside of Wooden Template A (Figure 44). Two nuts placed on both sides of Wooden Template A holds each of the threaded rods to Wooden Template A. This is done to the depth that you want the threaded rods to be inside the casting of the MM.
3. Block the hole of the MM Cavity with leftover clay from Part 2.
4. Apply Vaseline to the interior of the MM Cavity, as in Figure 45.



Figure 44: On the underside of Wooden Template A Figure 45: Apply Vaseline to Male Mold Cavity

The purpose of Wooden Template A is to hold the 3 pieces of threaded rod vertically and securely using nuts on both sides of Wooden Template A. The metal rebar rods are welded to the bottom of the threaded rod. This anchors the mounting bolts to the MM after the cement is poured into the cavity.

5. Place Wooden Template A at the center of the MM Cavity (Figure 46). Place bricks on the two sides of Wooden Template A to stabilize it. Wooden Template A needs to be placed at the center so that the manufactured male mold is symmetrical, and the center of the male mold aligns with that of the female mold

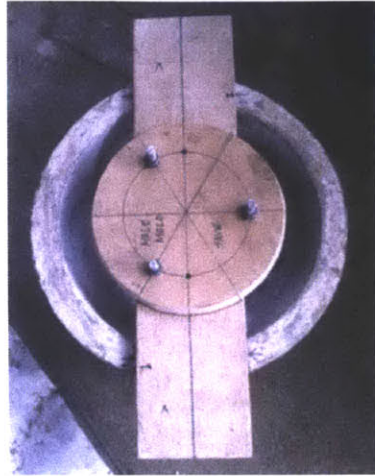

Figure 46: Wooden Template A at the center of Male Mold Cavity

6. Pour concrete made from Step 1 into the cavity, to the level of the top of the cavity and/or to the bottom of Wooden Template A. Make sure the steel structure on the back of Wooden Template A is submerged into the concrete (Figure 47). Also make sure Wooden Template A does not move during the pouring process.

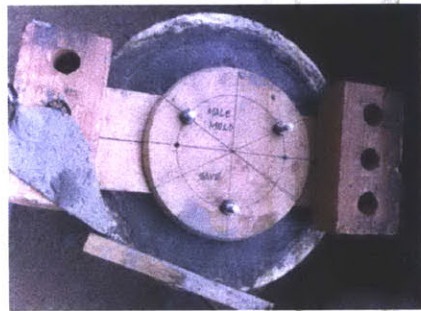

Figure 47: After pouring concrete into the cavity

7. Set the MM Cavity aside for 24 hour in the factory. Same as FM, the MM is also water cured after dismantling.

8. Remove the MM with a dowel and a hammer (Figure 48).



Figure 48: Removing the male mold

9. The MM is finished. After removing the MM, there will be some slight damage at the top caused by the dowel during the hammering process. Clean up the MM after removing it from the Male Mold Cavity and fill in the damaged area with auto body putty and/or cement.

The finished FM and MM should look like in Figure 49. They can then be installed on the Mani press. During installation, the molds must be properly aligned, which can be checked by pressing a new filter, then cutting the freshly pressed filter, lengthwise, into halves with a wire. Use a caliper to measure and compare the thickness of both the wall and base at various heights. Proper alignment ensures no variation in thickness throughout the filter element.



Figure 49: Finished female mold (left) and male mold (right)

7. Results

The data collected from surveys was compiled for customer reactions to the household water situation in Ghana and feedback specifically regarding C1 Common Interface design. Together with the findings from previous study by Weini Qiu about the Super Tunsai design, this study provides additional information on product feature preferences and consumer reactions in Ghana. This assists the author in determining a viable design choice of a new water filter product for middle and upper income customers.

7.1 Household Survey Results

Primary Water Source

Question: What is the primary water source in the house, namely, the water you mostly drink every day?

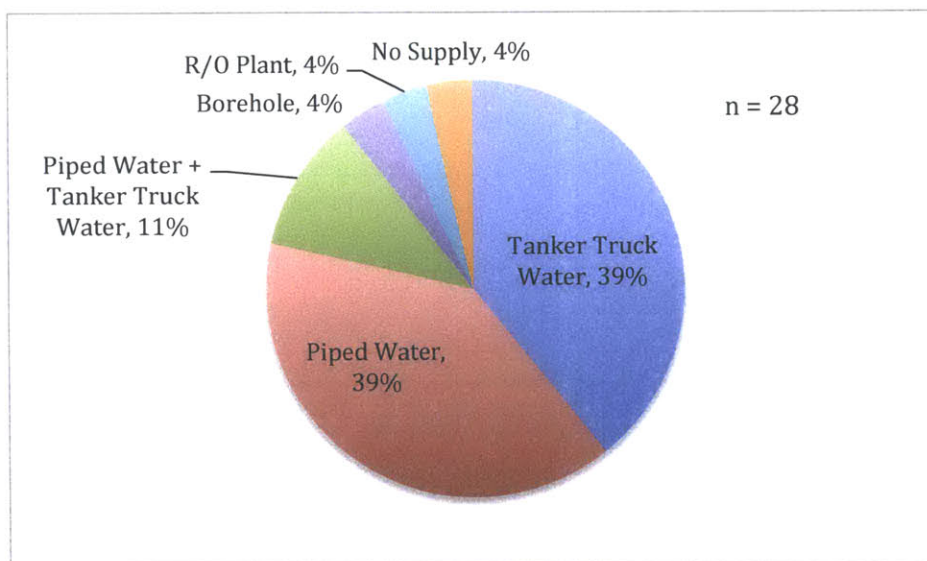

Figure 50: Primary Water Source in Accra and Kumasi

Knowing the customers' source of water helps the design team to understand the household water quality, and the degree of contamination the new filter will be treating. Piped water and tanker truck water remain the most common water sources in the study area, 39% each respectively. The author learned from the surveys that piped water was intermittent and was available to most respondents¹⁸ for only a few days every month. Families usually collect and store water when piped water is running, and purchase tanker truck water when piped water

¹⁸ All respondents in Accra and most respondents in Kumasi have intermittent water

stocks out. The local perception is that piped water and tanker truck water are clean for cooking, and that bottled and sachet water are clean for drinking. Small portions of respondents claimed to rely on boreholes and R/O plants for water use¹⁹.

“We buy tanker truck water only when our stored water runs out” – (Spintex, Accra)

“Our family drinks borehole water and it’s salty. I’d like a filter that can remove salt” – (East Legon, Accra)

Customer Preferences of HWTS Products

Question: What do you think is the most important feature of a water filter from the following options? (One choice per respondent)

- a. Health impact
- b. Durability
- c. Product price
- d. Size
- e. Time to treat
- f. Water taste and look

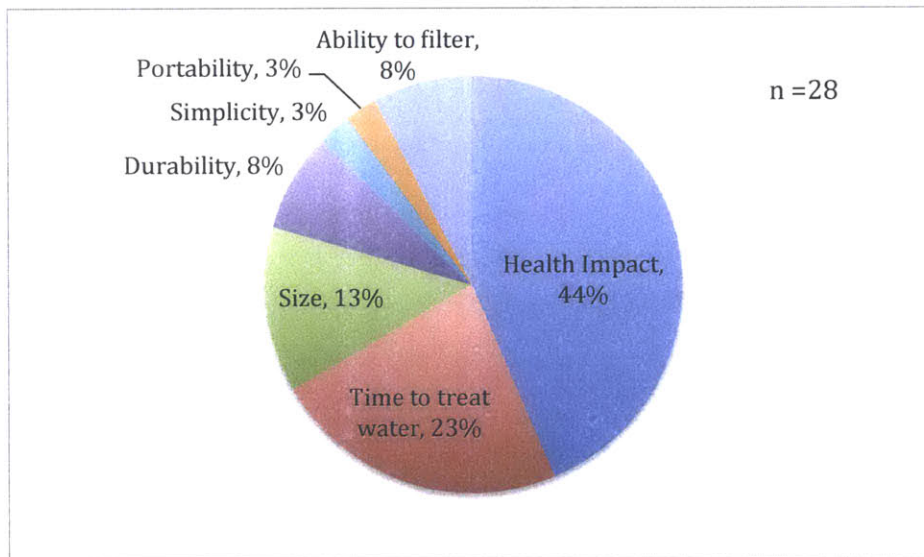

Figure 51: Customer Preferences of HWTS products

Customer preferences, considered as a significant factor in product development, gauge the design of the new water filter, and the study of them helps determine the marketing and

¹⁹ The author doubts the authenticity of the answer about R/O plant for drinking water treatment for the family

dissemination strategy. From Green’s (2008) and Qiu’s (2012) theses, the author has gained a basic understanding of the customer preferences regarding HWTS product features in Tamale, Ghana. This survey expanded the study area to Accra and Kumasi, which is a better representation of customer preferences in Ghana’s two largest cities.

Almost half of the respondents asserted that health impact is the most preferred functionality of a water filter. Regarding to time to treat water, respondents in Accra wanted fast water, and thought any time longer than 3 hours to treat a bucket of water (10L) is too long. In contrast, respondents in Kumasi claimed that the longer the treatment, the more water is purified. Depending on the household size, respondents had different comments on water filter sizes, with a common preference to have different sizes to choose from.

Price to Purchase-C1 Common Interface

Question: At what price would you like to purchase this filter? If not, why not?

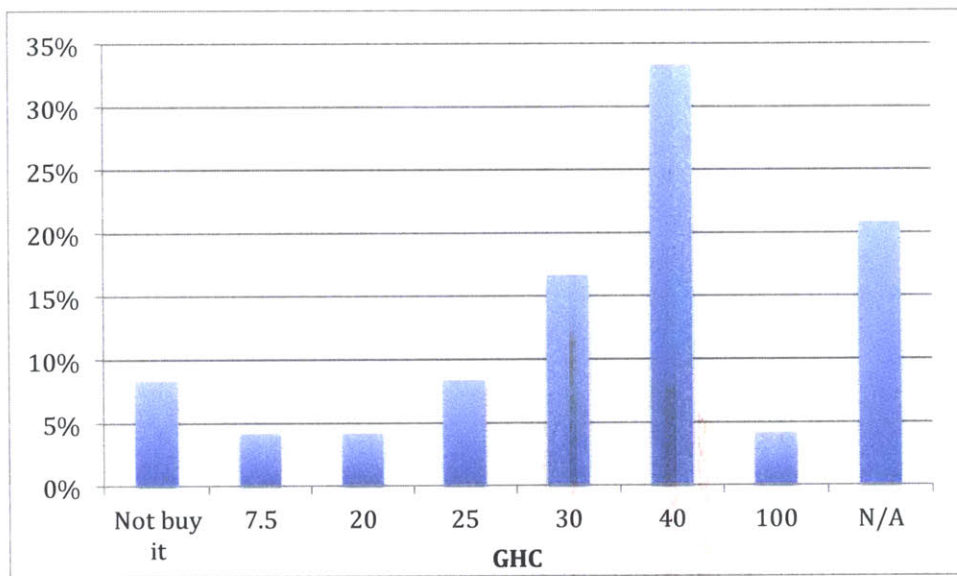

Figure 52: Price customers willing to pay for C1 Common Interface Filter

Understanding the price range offered by the potential customers not only helps set the final product price, but also assists the design team to constrain the production cost while meeting consumers demands, in order to generate the best profit for the organization. When C1 Common Interface Filter was presented to the interviewees, the most common first impression was that the filter was nice looking but too small. About a third of them said US \$20 (GHS40) is

an acceptable price for the market²⁰. US \$12.5 (GHS25) and US \$15 (GHS 30) are also popular quotes among respondents. A few people insisted they would not purchase such product (C1 Common Interface) because they have seen more advanced water treatment products from Swiss and UK, and they demand filter systems with higher sophistication.

Preferred Distribution Channel

Where would you most like to purchase such filters for your family? (One choice per respondent)

- a. Door to door
- b. General store
- c. Roadside stand
- d. Specialty store
- e. Street vendors
- f. Market day

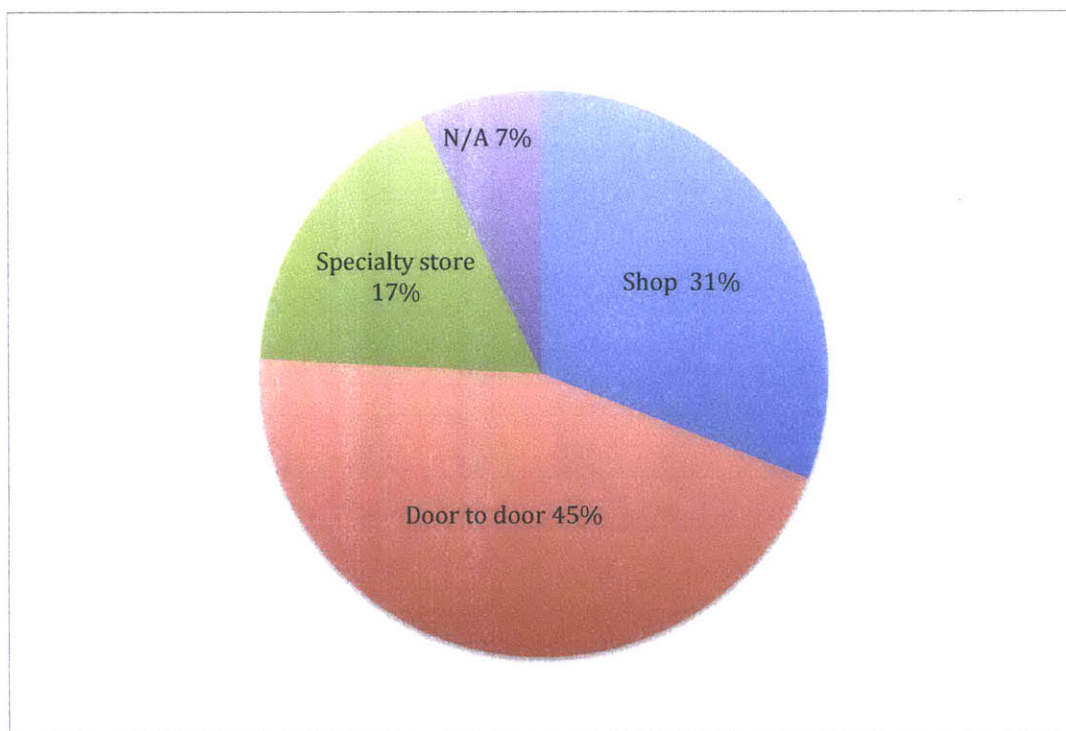

Figure 53: Customers' preferred distribution channels/purchasing methods

²⁰ The author personally thinks interviewees might have quoted a higher price to please the survey team. The actually price they will pay is potentially lower

Different families prefer different purchasing methods; therefore, a study of the potential distribution channels assists the team to better understand how to transport the new products from the factory to the end users, maximizing the efficiency. The most preferred distribution method is through door-to-door delivery, which might be quite costly for PHW or other distribution agents. Many people also liked to purchase such products in a shop so that they can bargain and ask for help in a problem. Specialty store remains another preferred distribution channel.

“I like door-to-door delivery, and please don’t sell it in the shop, because they are going to significantly increase the price” (East Legon, Accra)

“I’d like to purchase it in the shop so that I can negotiate the price and compare with other product” (Trinity Theological Seminary, Accra)

7.2 Products Assessment

The author proposes the following design criteria in order to assess the four different HWTS products based on the design perspective. The top two products from this assessment will go into a second-round assessment based on financial criteria. The new product that receives the highest score will be recommended for development. The products going through the assessment include: Super Tunsai from Cambodia, C1 Common Interface from China, PHW's AfriClay Classic Filter from PHW, and Ecofiltro filter from Guatemala.

First-round Assessment Design Criteria

1. Product performance:
 - a. High bacteria and turbidity removal
 - b. Fast flow rate
 - c. Durable and consistent filtering device

2. Product aesthetics:
 - a. Visually appealing
 - b. Product contribute to long term pride of ownership among users

3. User-friendliness:
 - a. Easy to set up, operate and maintain
 - b. No water spilling when filling, operating and dispensing water

4. Household suitability:
 - a. Product doesn't require electricity or piped water
 - b. Device easily and naturally integrates into the household setting

5. Job creation:
 - a. Produce local jobs

6. Transportability:
 - a. Easy to transport and distribute in terms of space and breakage

7. Manufacturing ease/difficulty:
 - a. Product material is locally available and accessible
 - b. Production is technically feasible for PHW

Since customers have a preference for product features, the 7 assessment criteria will be of different weight. Each assessment will be scored in a range of 1 to 10.

Table 10: Products Assessment Matrix (design criteria)

Criteria	Weight factor	Super Tunsai	C1 Common Interface	AfriClay Classic	Ecofiltro
Product performance	25%	8	8	8	7
Product aesthetics	25%	7	8	5	6
User-friendliness	15%	7	9	6	6
Household suitability	10%	9	9	7	7
Job creation	10%	8	5	8	8
Transportability	10%	8	9	7	6
Manufacturing ease/difficulty	10%	9	6	10	9
Final Score	Maximum score = 10	8.2	8.25	7.35	7.15

Product performance: As the premise of all water filters, product performance weighs the highest, 25%, of the assessment. Super Tunsai, C1 Common Interface and AfriClay Classic all have similar flow rates at 2~7 L/hour, bacterial removal rate at 99% and turbidity removal rate at 90%, therefore receive an equal score of 8. Ecofiltro filter have slightly lower flow rate at 1~2 L/hour, and therefore receive a score of 7.

Product Aesthetics: One of the primary goals of the new product is to have an aesthetic design, with a target at the high-end market, so this criterion also deserves the highest weighing factor, 25%. From the household survey, C1 Common Interface clearly received higher positive feedback in terms of appearance and industrial design, thus a score of 8 is assigned to this

product. Super Tunsai receives a slightly lower score of 7, followed by Ecofiltro of 6 and AfriClay Classic of 5.

User-friendliness: Through this research the author has realized that user interaction/experience influences customer confidence, which contributes largely to the continuing use of the product. This criterion, therefore, is another important aspect of assessment and is assigned a weighing factor of 15%. C1 Common Interface receives the highest score of 9 due to its human-centered design. Super Tunsai receives a score of 7 because its filter element needs more effort in maintenance and has less portability. AfriClay Classic and Ecofiltro follow with a score of 6.

Household Suitability: Since it's a household water treatment product, it's important to have a design that can be easily incorporated into a household setting. A weighing factor of 10% is assigned to this criterion. Super Tunsai and C1 Common Interface can be located anywhere in the house, whereas AfriClay Classic and Ecofiltro need to be placed on a table for tap clearance. Therefore, the former two designs receive a score of 9, and the latter two designs receive a score of 7.

Transportability: The ease of distribution is another key aspect of the design, and is assigned to a weighing factor of 10%. C1 Common Interface, receives a score of 8, is very easy to transport. The filter element is small and robust which induces no breakage issues during transportation. Super Tunsai, like the C1 Common Interface, can also be disassembled and requires minimal space for packaging. However, the filter element, flowerpot shaped, is more fragile and encounters some breakage issues. Super Tunsai receives a score of 7, followed by Ecofiltro of 6 and AfriClay Classic of 5.

Job creation: As a social enterprise, PHW's products should consider social impact, which in this case refers to the production of jobs. A weighing factor of 10% is assigned. To produce C1 Common Interface filters, PHW will most likely purchase the entire units from PureEasy, and distribute it with its own staff, which reduces job positions. This option receives a score of 5. The other three options receive the same score of 8 since they would keep all PHW's current positions, with no change.

Manufacturing ease/difficulty: This criterion is evaluated based on PHW's capability to manufacture the four products. AfriClay Classic receives a reference score of 10. Super Tunsai and Ecofiltro filter elements follow similar procedures to produce as AfriClay Classic, therefore receives a score of 9. C1 Common Interface filter elements follow a different set of procedures and require large investment in injection moldings, therefore, is the most difficult to produce and receives a score of 6.

Based on the crude estimation of scores, C1 Common Interface and Super Tunsai score the highest, 8.2 and 8.25 respectively, and remain the models carried forward to the second round, the financial assessment.

Second-round Assessment

Three criteria to measure the success of a business are profit, cash flow and return on investment (Goldratt, 2008). For the development of a new filter model, the success can be reflected by profit, requirement of initial capital and return on investment. Each criterion is assigned a weighing factor of 33%.

1. Profit

- a. Distributing at a price affordable in the target market
- b. Custom duties and challenges can be met
- c. Financially, producer benefits from this product in the long run (5 years in this case)

2. Requirement of initial investment

- a. Does not create a negative cash balance for the enterprise
- b. Capital investment is within the business's financial capability

3. Return on investment (ROI)

- a. Measurable ROI in the first five years

Table 11: Product Assessment Matrix (financial criteria)

Criteria	Weighing factor	Super Tunsai	C1 Common Interface
Profit	33%	7	3
Requirement of initial capital	33%	5	8
Return on investment	33%	6	5
Total score	Maximum score = 10	6	5.3

A budgeting analysis is conducted for the two products (spreadsheet attached in Appendix C). Based on several assumptions about inflation rate, tariff, sales volume, price, etc, the financial projection indicated that Super Tunsai receives a 5-year profit of \$6,411 (Net Present Value as of

2015), and C1 Common Interface receives -\$18,207 (Net Present Value as of 2015). For initial investment, Super Tunsai requires \$107,304, which is higher than that of C1 Common Interface at \$62,366. The overall ROI for Super Tunsai and C1 Common Interface are 0.06 and -0.29, respectively. Scores are assigned in the assessment matrix according to the financial analysis. Super Tunsai receives a slightly higher score at 6 compared to C1 Common Interface at 5.3.

Additional Analysis

An additional analysis of the two products is provided below to help PHW better understand the feasibility of the two products.

C1 Common Interface

Pros: This filter possesses an exterior that was very well received by its potential customers. The container, manufactured of polyethylene plastic, not only meets the health standard of storing water, but also reflects a high social aspiration of the family for an attractive appearance. C1 Common Interface design also includes a filter stand that offers tap clearance, which provides more adaptability in a household setting. To adopt the C1 Common Interface model, PHW would purchase 1000 units per batch from PureEasy, Dukang, or Ningbo Clean, which doesn't require large investment on injection moldings.

Cons: The filter element, made of diatomaceous clay that provides great adsorption functionality, is not indigenously available in Ghana. This means PHW would need to rely on the Chinese manufacturer in the long run, or find alternative clay for filter element manufacturing. C1 Common Interface's candle shaped filter element is different from PHW's hemispherical shaped filter element. The adoption of this design would result in a different manufacturing process, which induces additional cost for PHW at this stage.

In addition, the author has received feedback from investors and judges at business plan competitions that importing the entire units from Chinese manufacturers can be risky since PHW doesn't have any leverage on filter production. PHW's role can be easily replaced by any other business that is potentially larger and stronger, even by the Chinese manufacturer PHW is to work with. The lack of barriers to entry could be a potential issue for the business.

Super Tunsai

Pros: The manufacturing process of Super Tunsai filter element resembles that of PHW's AfriClay Classic Filter, thus it would be relatively easy for PHW to adopt this design. The distribution of Super Tunsai has proven successful in Cambodia, which, according to the World Bank, has similar economic scale and income distribution as Ghana, so this design represents a

less risky model to build upon. Similar to C1 Common Interface, Super Tunsai design also includes a stand for tap clearance, and can be disassembled for transportation. Additionally, this model has a favorable ROI in the long run based on the estimated financial projection. To use the design to create molds and produce filters in Ghana, PHW will need to obtain a no-cost license, either from PATH or Hydrologic.

Cons: Similar to C1 Common Interface, to manufacture Super Tunsai exterior requires investment in injection moldings that are often imported from China. While Hydrologic could ship the equipment to Vietnam for troubleshooting, it would present a challenge to PHW once any equipment malfunctions. The initial investment on injection moldings can be risky even the financial projections indicate a profit in the long run.

8. Distribution of AfriClay Deluxe Filter: A Business Strategy

The author has studied a case of pilot implementation in Cambodia where microfinance is used to distribute water filters, and had proved successful in generating higher sales and uptake rates compared to retail sales and door-to-door sales. The results are believed to be translatable since Ghana and Cambodia have very similar economies of scale and financial affordability (NationMaster, 2012).

Table 12: Comparison of Economy: Ghana vs Cambodia

	Cambodia	Ghana
GDP Per Capita	\$2,710	\$2,663
Income distribution > poorest 10%	2.9%	2.2%
Income distribution > richest 10%	33.8%	30.1%
Income distribution > richest 20%	47.6%	46.7%

Therefore, microfinance is recommended to PHW for the sales of the AfriClay Deluxe Filter. There are a few microfinance institutions (MFI) in Ghana that PHW could potentially work with, such as Opportunity International, Vision Fund Ghana, or CASUD (Dutch)²¹. The fact that Hydrologic has worked with Vision Fund, Cambodia for the distribution of Super Tunsai with microfinance makes Vision Fund, Ghana potentially a good partner due to its experience and familiarity with this process and product. In the Cambodian microfinance project, customers were financed for a 6-month loan with 18% interest. Together with Vision Fund, Cambodia, Hydrologic focused primarily on the existing microfinance institution clients for the sales.

Break Even Analysis

Pilot Implementation

PHW needs to implement a pilot project for the high-end product in the first year. The pilot requires purchasing filter exteriors from Hydrologic in Cambodia. The author recommends 1000 units to be imported for the pilot, with the corresponding price estimates shown in Table 12.

²¹ These websites of these MFIs are listed in Appendix G, in addition to a few other MFIs.

Table 13: Cost estimates for AfriClay Deluxe Filter

Criteria	Exterior price from Cambodia (Estimates)	Shipping cost (Estimates)	Custom tax (Ghana Revenue Authority, 2011)	Filter element from PHW
Cost	\$12 per unit	\$2 per unit	10%	\$3.2 per unit

With the above information, the author conducted a break-even analysis to find out how fast PHW needs to sell the 1000 units in order to break even with operating expenses and manufacturing cost. If sales of AfriClay filters are considered as the sole income for the enterprise, and AfriClay Deluxe Filter is priced at \$30 per unit, PHW needs to sell the 1000 units in 66 days in order to break even. Some assumptions and estimates are listed below:

- Operating expenses for AfriClay Deluxe = \$20,000 per year²²,
- Exclude income source from donations and grants,
- Exterior cost from Cambodia = \$12 per unit,
- Shipping & tax = \$2 per unit.

Table 14: Break-even analysis for the pilot

		Pilot (1000 units from Cambodia)
Operating expenses		-\$20,000 per year
Cost of production	Exterior	-\$18,400 per 1000 units
	Filter element	
	Shipping	
	Tariff	
Sales of AfriClay Deluxe		\$30,000 per 1000 units
Break even point		0.58 year = 212 days

²² Bank Charges (\$800) + Household Supplies (\$2,300) + Lab Expenses (\$1,930) + Marketing (\$5,000) + Payroll Tax (\$1,800) + Salary (\$7,000) + Miscellaneous (\$1,200). Estimates from Total Expenses 2012.

The break even time versus price is calculated and shown in Figure 43. As the price goes up, the time pressure for break even reduces.

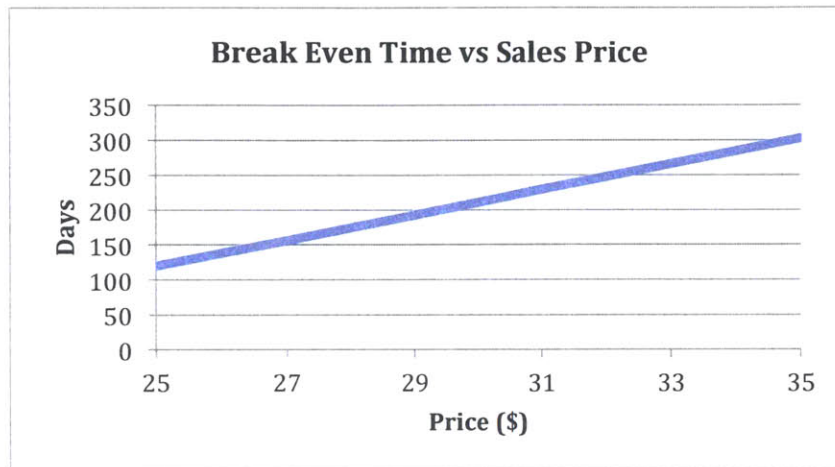

Figure 54: Break Even Time vs Sales Price

The formula used to perform the calculation is:

$$-\text{Operating expenses} \times \text{time} - \text{Cost of production} + \text{Sales of AfriClay Deluxe} = 0$$

$$(-20000) \times t - 18400 + 30000 = 0$$

$$\Rightarrow t = 0.58 \text{ year} = 212 \text{ days}$$

Local production

When and if the pilot implementation proves successful, PHW needs to purchase injection molds and molding materials from China. According to GhanaWeb, as industrial machinery, injection molds fall into the zero rate duty category, which has minimal tax responsibility at the custom (Ghanaweb, 2002). Based on the author's research and interactions with PATH, the cost estimates (assumptions) are listed as below:

- Operating expenses for AfriClay Deluxe = \$5 per unit,
- Equipment expenses = \$50,000,
- Shipping & tax = \$10,000,
- Exclude income sources from grants and donations.

Table 15: Break Even Analysis for Local Production

		Local production
Operating expenses/unit		-\$5
Equipment expenses		-\$50,000
Shipping and custom tax		-\$10,000
Cost of production	Filter exterior	\$10 + \$3.2 = -\$13.2 per unit
	Filter element	
Price		\$30 per unit
Break even point		5,085

The formula used to perform this calculation is:

$$(\text{Price} - \text{Cost of production} - \text{Operating expenses/unit}) * \text{Quantity} - \text{Equipment expenses} - \text{Shipping \& custom tax} = 0$$

$$(30 - 13.2 - 5) * Q - 50000 - 10000 = 0$$

$$\Rightarrow Q = 5085$$

The break-even quantity versus time is calculated and shown as below. As price goes up, the break-even quantity reduces.



Figure 55: Break Even Quantity vs Price

5-year demand forecasting for Tamale, Ghana

The Bass Diffusion model describes the process of how new products are adopted as an interaction between users and potential users. It was proposed in 1969 by Frank Bass who was at

the time a marketing professor at Purdue University. It is widely recognized in marketing for its capability of product and technology forecasting, and provides some credible answers to uncertainty associated with introducing new products (Uncles, Ehrenberg, & Hammond, 1995). The Bass Diffusion Model is used in this project to forecast the demand of the AfriClay Deluxe Filter in Tamale, Ghana.

Parameters required for this model are the innovator rate, imitator rate, and market size. Innovators are individuals who decide to adopt an innovation independently of the decisions of other individuals in a social system (Bass, 1969). Imitators refer to adopters who are influenced in the timing of adoption by the pressures of the social system, the pressure increasing for later adopters with the number of previous adopters (Bass, 1969). During field surveys in Ghana, one of the questions asked by the survey team was: What would influence your decision about purchasing a filter like this? The answers included “I rely on my own judgment”, “friends and peers”, “I’d not buy it”, etc. The author estimated the innovator and imitator rates based on the fraction of these answers. The market size was considered as the entire number of households in urban Tamale. According to Ghana Statistical Service in 2012, the population in urban Tamale District is 274,000. Assuming an average family size of 7; the total number of households is 39,140, which is estimated to be the market size for the model. Therefore, the model parameters are assumed as:

- Innovator rate $p = 0.05$
- Imitator rate $= 0.4$
- Market size $= 39,140$

The Bass Equation is as below

$$n = (N - N_{t-1}) * (p + q \frac{N_{t-1}}{N}), \text{ where}$$

n = new users every year

N = total market size

N_{t-1} = total users at the beginning of year t

p = innovator rate

q = imitator rate

Rearranging the equation, we get

$$n = Np + (\frac{q}{N} - p) * N_{t-1} + \frac{q}{N} * N_{t-1}^2, \text{ which is a quadratic equation of } n \text{ \& } N_{t-1}$$

Plugging in the parameters of p , q and N , and taking N_0 as 1000 (from pilot), the 5-year demand forecasts are calculated and shown in Table 14.

Table 16: 5-year Demand Forecasting in Tamale

Beginning of year	2014	2015	2016	2017	2018
New users	1000	1533	1513	1529	1581
Total users	1000	2533	4047	5576	7157

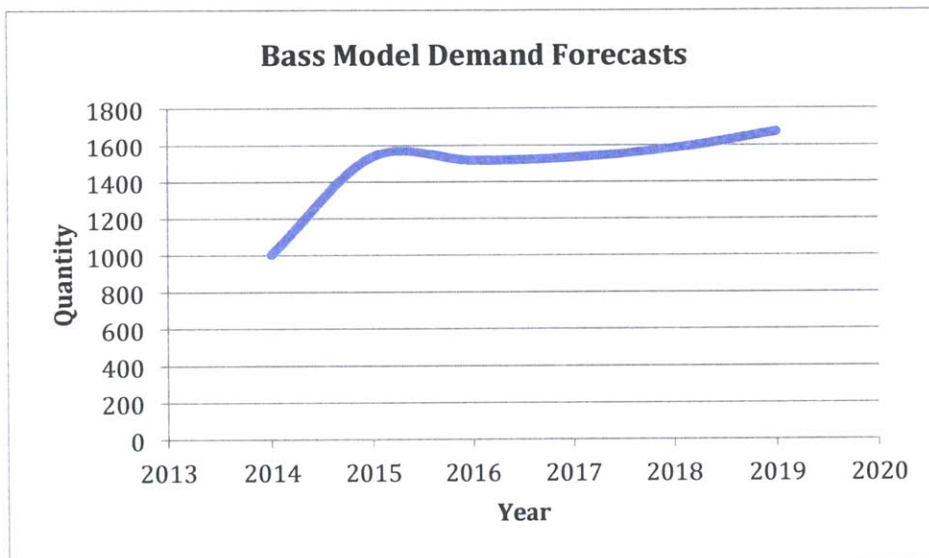

Figure 56: 5-year Demand Forecasting in Tamale at \$30 per unit

The forecasts indicate that once local production starts after the pilot implementation, the average demand in urban Tamale for the AfriClay Deluxe will be approximately 1539 units per year at the price of \$30 per unit. The Bass Diffusion Model performs well when there is extensive historical data. One flaw in this analysis is that there was only one year of historical data, which is the 1000 units pilot implementation, when the model was applied. The lack of historical data limits the accuracy of the forecasting.

Supply Chain Bottleneck Analysis

In order to answer the question: What would prevent the filters from getting to the end users the most? The author conducted a bottleneck analysis for PHW’s supply chain, of which the three major components are “manufacturing”, “sales” and “distribution”.



Figure 57: Major Components of AfriClay Deluxe Supply Chain

According to PHW's financial statement for Year 2012, the ceramic filter sales are \$55,336 in total. Since PHW's filters are priced at \$25 per unit. An estimated number of 2213 filters were manufactured and distributed in 2012. Therefore, for PHW:

- Manufacturing capacity > 2213 units per year
- AfriClay Deluxe Sales ~ 1539 units per year
- AfriClay Classic Sales: unknown
- Distribution capacity > 2213 units per year

Depending on the sales of AfriClay Classic Filters, the bottleneck of the enterprise's supply chain could be manufacturing capacity, sales magnitude or distribution capacity.

If the bottleneck turns out to be manufacturing capacity, PHW needs to increase the efficiency of production. A few recommendations about how to increase the efficiency are listed as below:

1. Highly specify the work content, timing and outcome in the factory. This way, employees follow a well-defined sequence of steps for a particular job, which enables them to see and address deviations immediately.
2. Production flows along a simple, specified path. And each worker knows who provides what to him, and when. This way, goods flow to a specific person or machine, and no ambiguity exist for the production.
3. Improvements to processes, worker & machine connections, or flow path must be made in accordance with the scientific method. Goals or judgments should not be based on random guess; instead, they should be based on formal hypothesis and scientific proof (Spear & Brown, 1999).

If the bottleneck turns out to be sales magnitude, PHW needs to increase marketing effort to boost sales volume. In the meanwhile, the enterprise needs to ensure the quality of their products to maintain a high customer satisfaction rate, which is essential, as Ghanaian households tend to rely more on friends and peers' experience than their own judgment.

If the bottleneck turns out to be distribution capacity, PHW needs to increase the distribution force size. In the Cambodian pilot project, Super Tunsai sales were 5000 units per 10 sales agents, i.e. 500 units per agent. PHW could take this number as a reference sales efficiency for AfriClay Deluxe Filter.

Identifying the bottleneck helps PHW understand the corresponding strategy to improve the supply chain efficiency and better manage the enterprise. It's critical to understand that bottleneck may shift from one area to another at different stage of the business.

9. Conclusion

In urban areas of Ghana, customers primarily rely on piped water (39%) and tanker truck water (39%) as their water sources. Health impact, time to treat water, and size are the most valued features for a water filter from the Ghanaian's perception. The survey has shown different customer attitudes towards the time to treat water. In Accra, where it's faster paced, customers would like the flow rates to be greater than 3L/hour. In contrast, in Kumasi and Tamale, customers are fine with low flow rates as long as it purifies water. Door to door sales are the most preferred distribution method for the AfriClay Deluxe Filter.

A plastic exterior is more feasible than a ceramic exterior for the AfriClay Deluxe Filter due to manufacturing difficulty, transportation challenge and high cost for the ceramic containers. In fact, the majority of HWTS products in developing countries use plastic containers as their exteriors. So do all the four products that were assessed in this thesis.

The Super Tunsai and C1 Common Interface are equal in terms of their design assessment, and the Super Tunsai is superior in terms of the financial assessment. Therefore, from the two rounds of assessments and the analysis, the author concluded that **Super Tunsai** represents a better model for PHW to adopt for further development.

In Cambodia, Hydrologic priced their product at \$22 per unit during pilot implementation. The enterprise, namely Hydrologic, was unable to recover the entire cost from the sales of its product. If PHW has equally or less efficient operating system than Hydrologic, it needs to price the product higher in order to make the project profitable.

Based on the Bass Diffusion Model demand forecasting, the average yearly demand for the AfriClay Deluxe is 1,500. From the Cambodian pilot implementation, the sales rate was approximately 500 per sales agent. Therefore, PHW needs at least three sales agents for the distribution of this high-end product. When the new product is launched, the sales will be the bottleneck of the supply chain. As the market accepts this product, PHW's manufacturing and distribution capacity will become the bottleneck.

10. Recommendations

After PHW conducts the pilot implementation, and when the enterprise decides to purchase injection molds for local production, Qualiplast, the largest household plastics manufacturer in Ghana, can be a potential partner. PHW also has the option of contacting Hydrologic's injection molds supplier in China for negotiation.

The recommended price for the AfriClay Deluxe Filter is \$30 per unit. PHW should work closely with larger NGOs for the dissemination of its products. One possible sales strategy could be that PHW issues \$10 coupons for the AfriClay Deluxe in the sales region, and potentially claims the coupons from larger NGOs, such as UNICEF or Rotary as a way to subsidize the filter cost. Customers are encouraged to pay in order for them to value the benefits of the products.

During pilot implementation, PHW needs to sell the 1000 units in 212 days in order to break even on expenses. At this period, sales will be the bottleneck of the supply chain; hence, PHW should focus on marketing and product promotion in order to maximize profits and utilization of the business.

During local production, if PHW chooses to disseminate both AfriClay Classic and AfriClay Deluxe, and to different target markets, manufacturing capacity will soon become the bottleneck of the business. PHW factory will fall short on production due to the higher demand in the market. At this period, the enterprise should primarily focus on increasing manufacturing performance in the factory. When manufacturing capacity is brought up, the distribution capacity should be increased accordingly by adding more distribution force or adopting better distribution models.

At microfinance, together with the microfinance institutions (MFI), PHW should first focus on existing MFI clients, i.e. account holders as the primary market, because the Cambodian pilot indicated a much higher uptake rate within existing clients. As the primary market becomes saturated, the focus needs to be shifted to the broader market.

10.1 Recommendations for Further Developing AfriClay Deluxe Filter Product

If PHW decides to modify or further develop the AfriClay Deluxe Filter product instead of directly using the Super Tunsai design, a few recommendations have been made for the new filter product. PHW has been through substantial growth focusing on AfriClay Classic Filter, upon which the new product should be built. Based on the research of consumer preferences and local infrastructure conditions, the new product should possess the following features:

1. Hemispherical filter element in design:

Workers at the factory are becoming more efficient with filter element manufacturing, quality control, distribution, etc. Maintaining the current hemispherical filter element design ensures the stability and smooth operation of the organization locally in Tamale, Ghana.

One filter element PHW is advised to add for the Accra market is activated carbon/charcoal in the receptacle. This provides additional treatment just before water is dispensed from the tap, and enhances water taste. This complementary element helps AfrClay Deluxe Filter meet Accra customer demand for a sophisticated filter system. This additional filter element, however, is not demanded from any respondents in Kumasi or Tamale according to the survey.

2. An exterior comprised of multiple components that can be assembled and disassembled:

One of the most prominent drawbacks, received from surveys, of AfriClay Classic Filter is that the plastic container is not aesthetically appealing. The fact that the receptacle resembles a garbage bin is a major barrier for the product to expand into the high-end market. An exterior consisting of multiple parts eliminates this perception by incorporating more elements into the design and by offering a cosmetic upgrade due to high quality injection molding materials. Additionally, it provides more transportability for distribution as well as more portability in the household. To implement this recommendation requires an investment in injection moldings and plastic material. But the cost will be replenished as PHW performs mass production of filters.

3. Provide customers with options for sizes, transparencies and colors:

Different filter sizes suit different families sizes. The survey results indicated that there is a range of filter sizes desired by the customers, with 15L of receptacle size being the most commonly valued. PHW could also try containers with different transparencies, for example, transparent, semi-transparent, and not transparent. The color of blue has been confirmed by PATH to be a commonly accepted non-transparent color for filters, as it provides the mental perception of fresh water. After capturing the most popular option, PHW can adjust production accordingly.

4. Incorporate a filter stand into the design:

A filter stand provides space for tap clearance to eliminate the need of placing filters on tables, bricks, and other heights. Incorporating a filter stand could also reduce the extra storage

receptacle size, which enhances the overall filter appearance. This design provides a good user experience that ensures sustained use and valued products.

10.2 Vision Statement for AfriClay Deluxe Filter

Product Description: The AfriClay Deluxe Filter will be an effective and aesthetic ceramic pot water filter, marketed and manufactured in Ghana, that not only provides needed health benefits, but also meets consumer aspirations, in order to capture high demand from middle and upper income families.

Benefit Proposition:

1. Adds an additional barrier and protection from contaminated water,
2. Provides safe household drinking water at an affordable price,
3. Reflects a high social aspiration, and provides a pride of ownership to customers.

Key Product Goal:

1. First product introduction in 2014,
2. A positive 5-year Return on Investment (ROI),
3. Reaches 1500 households by 2015,
4. Supports cross subsidy of the AfriClay Classic for low income customers.

Primary Market: Middle and high-income families

Assumptions and Constraints:

1. Plastic exterior,
2. Hemispherical filter element,
3. Consist of multiple components for easy assembly and transport,
4. Provide a few options for size, transparency and color,
5. Incorporate a filter stand.

Stakeholders:

1. Pure Home Water,
2. End users,
3. NGOs,
4. Distributors and retailers.

10.3 Challenges and Recommendations for Future Studies

Time and Economic Limitations

Developing, producing and marketing a new product require fairly large investment (Ulrich & Eppinger, 2012). Due to the time pressure, it's been challenging to manage the designing process, such as in-depth market research and prototype manufacturing. Despite the author's field trips to PATH and PureEasy, and efforts to gather information on potential designs, it was difficult to translate the information into actual design in a short amount of time. The fact that students only travel to Ghana for one trip exerts much pressure for action and results.

Data Limitation

Data collection and analysis are major components of market research. They provide key information for the industrial designer to consider aesthetics, ergonomics, user-interface, and other functions of the product. The data collection for our high-end water filter was performed between January 5th and January 23rd, 2013. Field research at GWC and Weija Water Treatment Plant provided essential information for the author to understand the water supply and water quality issues in the country. However, the lack of physical data still presented difficulty to completely understand the pressing issues of the water crisis.

During the field research, 40 customer surveys were conducted, which greatly informed the author of consumer preferences for a HWTS product. However, some survey questions could have been better designed. For example, the author presented multiple choices for the most important feature of a water filter. The majority of the answers are health impact, which might have been biased or a courtesy answer that doesn't necessarily represent the respondents' authentic perception. Future studies are advised to not present an obvious answer in such way. Despite the efforts to travel across the country, the limited fieldwork surveys nonetheless still fails to provide a comprehensive understanding of the entire country's willingness to pay and preferences.

Also, due to a lack of awareness of the culture and societal conditions, many potentially applicable methods of survey were not utilized, such as questionnaire and online survey. Customer interview was the only form of survey the team performed, which doesn't necessarily represent the most efficient and effective way of receiving feedback. Future researchers should not limit their surveying method to face-to-face interviews.

Recommendations for Future Studies

In the development process of Super Tunsai, PATH had several alternative designs, as in Figure 43. Future studies could focus on the analysis and improvement of these designs based on

the proposed assessment matrix in Chapter 6, Ghanaian consumer preferences, and manufacturing, distribution feasibilities.

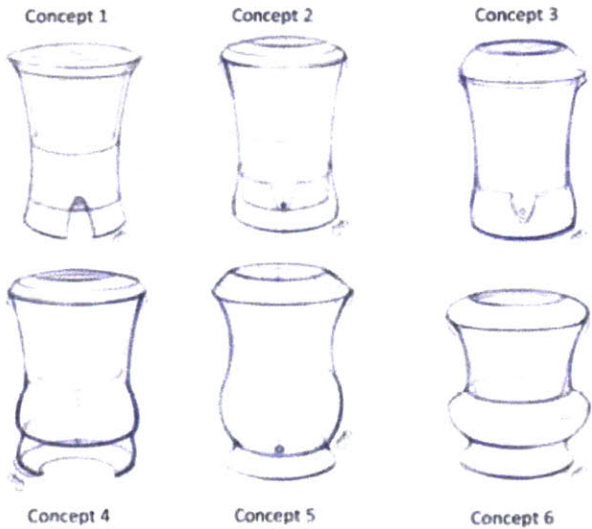

Figure 58: Six concepts for Super Tunsai Filter (Murray, 2011)

For this project, the author used a reference prototype, C1 Common Interface Filter from China, for field research in Ghana. Future researchers may take the findings of this research, and make their own prototypes for field studies during IAP. Future researchers should consider placing prototypes into households for trials and collecting feedback from these pilot users. As discussed in the limitations section, surveying methods should not be restricted to only door-to-door interviews. Questionnaires and online surveys, especially in universities such as University of Ghana, KNUST, will be more effective for getting authentic information.

Future researchers are also advised to take the course “2.739: Product Design and Development”, a joint course between Sloan School and the Department of Mechanical Engineering, in the Fall Semester. This course provides key concepts and knowledge about developing a new product, and will serve as a great reference for any continuation of this endeavor.

Bibliography

Abt Associates, Inc. (2012). *Distribution of Ceramic Water Purifiers through Direct Sales and Retail Sales Pilots in Cambodia*. Bethesda: PATH.

Adrienne Kols, J. G. (2012). *Sparkling Demand for Household Water Treatment Products*. Seattle: PATH.

Bass, F. (1969, March). A new product growth for model consumer durables. *Management science*, 1825.

Cheng, K. (2013). *Monitoring and Evaluation of the Ceramic Filters in Northern Ghanaian Households*. Cambridge: Massachusetts Institute of Technology.

CIA. (2012). *The World Factbook*. Ghana: CIA.

Elmore, A., Moluf, D., Wilson, P., & Arevalo, M. (2009). *Ecofiltro's Ceramic Pot Filter Experience in Guatemala*. Missouri University of Science and Technology.

Ghana Revenue Authority. (2011). *Custom Guide*. Accra, Ghana: Custom Division of Ghana Revenue Authority.

Ghanaweb. (2002). *Tariff Structure for Imports 2002*. Retrieved May 12, 2013, from www.ghanaweb.com/GhanaHomePage/economy/import_duty.php

Goldratt, E. (2008). *The goal*. Great Barrington, MA: North River Press.

Green, V. (2008). *Household Water Treatment and Safe Storage Options for Northern Region Ghana: Consumer Preferences and Relative Cost*. Cambridge: Massachusetts Institute of Technology.

Heierli, U. (2007). *Why is it so hard to bring safe water to the poor-and so profitable to sell it to the rich*. Berne: Swiss Agency for Development and Cooperation.

Hydrologic Social Enterprise. (2012). *About Hydrologic*. Cambodia.

Jackson, J. (2001). *Introduction to African Civilization*.

Kols, A. (2008). *Finding from Investigation of User Experience with Household Water Treatment and Storage Products in Andhra Pradesh, India*. Seattle, WA: PATH.

Mahin, T. (2007). *Review of Thesis "Ceramic silver impregnated pot filters for household drinking water treatment in developing countries"*. Cambridge: Massachusetts Institute of Technology.

- Miller, M. (2012). *Hemispheric Ceramic Pot Filter Evaluation, Optimization, and Quality Assurance Program in Northern Ghana*. Cambridge: Massachusetts Institute of Technology.
- Murcott, S. (2010). *Ecofiltro Product Models, Prices, and Sizes*. MIT, Civil Engineering, Antigua.
- Murcott, S. (2012). *Request for Proposal: Ghana Project*. Cambridge: Massachusetts Institute of Technology.
- Murray, M. (2011). *Newly designed ceramic water pots for low-income households*. Seattle: PATH.
- NationMaster. (2012). *Economy Stats: Ghana vs Cambodia*. Retrieved 3 11, 2013, from nationmaster.com: <http://www.nationmaster.com/index.php>
- PATH. (2012). *Guide to New Water Filters with C1 Common Interface*. Seattle: PATH.
- PATH. (2012). *Piloting retail and direct sales model for household water treatment products in Cambodia*. Phnom Penh, Cambodia: PATH.
- PATH. (2011). *User Testing of Household Water Treatment and Storage Products*. Seattle: PATH.
- PureEasy. (2012). *About PureEasy*. Guangzhou: PureEasy.
- Qiu, W. (2012). *Ghana's Regional Development in Economics, Education and Natural Resources, with a case study on customer preferences for household water treatment and storage products*. Cambridge: Massachusetts Institute of Technology.
- Society for Technology and Action for Rural Replacement. (2012). *Access to Safe Water to the Bottom of Pyramid: Strategies for Disseminating Technology Benefits*. New Delhi: Department for International Development.
- Spear, S., & Brown, K. (1999). Decoding the DNA of the Toyota Production System. *Harvard Business Review* , 1.
- Sutton, J., & Kpentey, B. (2012). *An Enterprise Map of Ghana*. Ghana: McGraw-Hill.
- Ulrich, K., & Eppinger, S. (2012). *Product Design and Development*. Cambridge: McGraw Hill.
- Uncles, M., Ehrenberg, A., & Hammond, K. (1995). Patterns of Buyer Behavior: Regularities, Models and Extension. *Marketing Science* .
- WHO. (2012). *Guidelines for Drinking Water Quality*. WHO.
- World Bank. (2011). *Ghana: Economy*. Ghana: World Bank.

Appendices

Appendix A: Instruction for Assembly of C1 Common Interface



Appendix B: Household Survey

Instructions for surveyors

1. Read every question exactly as written in the questionnaire – do not improvise
2. Read questions slowly enough that the respondent can understand
3. Wait for the respondent to answer
4. If the respondent can't answer repeat the question
5. Remain absolutely neutral about the respondent's answers
6. Don't act embarrassed about a respondent's answers to sensitive questions³²
7. Never suggest an answer unless the instructions say to read the answers
8. Don't repeat the respondent's answers
9. Conduct the interview in private
10. Do not give advice to respondent's on personal matters
11. Answer directly any questions the respondent has about the purpose of the survey
12. Listen carefully to the respondent's answer

Target: Middle and upper class families in Accra and Kumasi; 5 surveys per day

Hello, my name is Shengkun Yang. This is Abel Manangi and George Neequaye. We are a research team from MIT in the United States. We are conducting a survey about a water filter product we are currently developing. Can we speak with you and ask a few questions about a prototype we have? Your comments and feedback will be very valuable for us to improve our product. This is not a sales team, meaning we are not selling or promoting our product. Instead, we are a research team and the survey is purely for research purposes. Your responses will be kept confidential. Are you willing to participate?

--If NO, thank you for your time and we will end here.

--If YES, do you have any questions or might we begin?

1. What's the source water in the house, namely the water you mostly drink every day?
2. How many people are there in your family?
3. Have you or any of your family members experienced diarrhea in the past year?
4. What do you think of the drinking water quality in your house?
5. What's your occupation?
6. What's your first impression on the filter? (You may choose to describe it in 2~3 words)
7. Have you had similar product before? If so, how was your experience with it?
8. What do you think is the most important feature of a water filter?
 - a. Health impact
 - b. Durability
 - c. Product price
 - d. Product size
 - e. Time to treat
 - f. Water taste and look
9. What influences your decision about purchasing a product like this?
 - a. Family members
 - b. Health professional
 - c. Friends and peer group
 - d. Health issues
 - e. Other
10. At what price would you like to purchase such filter? If not, why not?
11. Where would you most like to purchase such filters for your family?
 - a. Door to door
 - b. Shop
 - c. Roadside stand
 - d. Specialty store
 - e. Street vendors
 - f. Market day
12. What final comments or questions do you have for our filter?

Thank you very much for your time! We appreciate your feedback!

Interviewer: Shengkun Yang

Recorders: Abel Manangi, George Neequaye

Accra	Interviewee 1	Interviewee 2	Interviewee 3	Interviewee 4	Interviewee 5
Occupation	Restaurant owner (Indian)	Restaurant owner	Gym owner	Caretaker	Driver
Source Water	R/O plant	Tank water	No water supply	Tap water	Borehole water
Drinking Water Quality Perception	Good	Not good	N/A	OK	Bitter and salty
First impression of prototype	Good, useful for families, easy to use	Good	Good	How to clean? Can it filter salt?	How to clean? Can it filter salt?
Similar product awareness	Yes, in India	No	No	No	No
Most important features for a filter product	Health impact	Health impact	Health impact	Simplicity, time to treat, and price	Simplicity, time to treat, and price
Decision influence	Functionality	Health	Health	All the above	All the above
Price range	Not buy it	GHC 50	GHC 50	GHC 5~10	GHC 5~10
Purchasing method	N/A	Shop (able to ask questions and bargain)	Door to door	Shop	Shop
# of family members	N/A	N/A	N/A	5	10
Diarrhea experience in the past month	Yes	Yes	Yes	Yes	Yes
Final comments	Spread awareness	Spread awareness	N/A	Make it bigger	Make it bigger
Accra	Interviewee 6	Interviewee 7	Interviewee 8	Interviewee 9	Interviewee 10
Occupation	Caretaker	Cleaning agent	US student	Accountant	Unemployed
Source Water	Tap water	Overhead tank	Overhead tank	Overhead tank	Well
Drinking Water Quality Perception	OK	OK	Good	Good	Good
First impression of prototype	How to clean, can it filter salt?	Small, ideal for office	Innovative, good to invest in	Not different from other products in the market	How to clean, time to treat water
Similar product awareness	No	Yes, he has AfriClay Classic Filter in use	No	Yes	No
Most important features for a filter product	Simplicity, time to filter, and price	Durability, size, time to treat water	Portability	Durability	Durability, size
Decision	All the above	Functionality	Health	Health	Health, cost and

influence					peers
Price range	GHC 5~10	N/A	N/A	Not buy it	N/A
Purchasing method	Shop	Door to door	Door to door	Talk to teachers and community leaders	Shop
# of family members	5	12	6	7	11
Diarrhea experience in the past month	Yes	Yes	N/A	No	No
Final comments	Make it bigger	A filter connected to the source will be great	Wants to see the product on the market	Fragile	N/A
Accra	Interviewee 11	Interviewee 12	Interviewee 13	Interviewee 14	Interviewee 15
Occupation	Event manager	N/A	Pastor	Pastor	Pastor
Source Water	Piped + tank water	Pipe water (drink it too)	Tank water	Tank water + sachet water	Tank water
Drinking Water Quality Perception	Good	OK	Good	Good	Good
First impression of prototype	Small, doesn't cool water, time to treat is long, best for rural area	It feels like being able to clean water	How to clean filter	Nice product, how to convince people it's clean?	Good, simple design, aesthetic
Similar product awareness	Yes	No	Yes	No	Yes (believed the water was OK after filter)
Most important features for a filter product	Size, health and time	Health and size	Ability to filter water, size	Health, time to treat	Health, time to treat
Decision influence	Location	N/A	Health	Friends and peers	Family member
Price range	GHC 30	GHC 40	No idea	GHC 25	GHC 30~50
Purchasing method	Shop	Door to door	All the above	Door to door	Advertising to beat sachet water
# of family members	3	10	7	5	5
Diarrhea experience in the past month	No	No	No	Yes	No
Final comments	Giant reservoir + a filter element in the	Don't leave the product for the shops to sell,	It will be good if the filtered water can be	Color and look good. Raise the stand	Connect with hospital and ministry

	village (CWS model?)	otherwise the price will rise	cold		
Accra	Interviewee 16	Interviewee 17	Interviewee 18	Interviewee 19	Interviewee 20
Occupation	Pastor	Pastor	Pastor	Pastor	N/A
Source Water	Tank water	Tank water	Tank water	Tank water	Tank + pipe water
Drinking Water Quality Perception	Tank water: moderate; sachet water: good	Never drink from tap water; sachet is fine	Water is sometimes hard	Tank water not safe	OK
First impression of prototype	Very good	Portable, small in size	How to see dirt? Size is small, plastics is better transparent	Design is good	Not work
Similar product awareness	Old model took too long to treat, so they stopped using it	No	Yes, 4 years ago	Yes	Yes, they treat water at the source
Most important features for a filter product	Time to treat	Filter element, health, time to treat	Health	Health impact, time to treat	Health and size
Decision influence	Health issue	Health issue	Anyone used it before	Health professional	Health issue
Price range	GHC 30~50	GHC 20	GHC 80~120	GHC 30	Don't know
Purchasing method	Shop, specialty store	Door to door, specialty store	Door to door	Door to door	Door to door
# of family members	6	6	5	5	5
Diarrhea experience in the past month	No	No	No	No	No
Final comments	Size is too small	Will sell well in rural area	Filter can be used at the poly tank	Cooling water will be great	Advertise in school and Tamale area

Tamale	Interviewee 1	Interviewee 2	Interviewee 3	Interviewee 4	Interviewee 5
Occupation	Headmaster	Nurse	Shop owner	Street vendor	Worker
Source Water	Pipe water	GWC	GWC	GWC	Pipe water
Drinking Water Quality Perception	Safe to drink	OK to drink	OK	Safe to drink	Not so safe
First impression of prototype	Work done by a genius, never seen such	Nice	Nice	Nice device	Good product

	product before				
Similar product awareness	No	No	No	No	No
Most important features for a filter product	Ability to clean water, 5 hours is not long	Health impact	Health impact	Time to treat water	Health impact
Decision influence	Himself	Family member, health professional	Peers	Family member	Health professional
Price range	GHC 40	GHC 25	GHC 30	GHC 25	GHC 20
Purchasing method	Door to door	Store, door to door	Door to door	Market day	Door to door
# of family members	10	6	8	9	8
Diarrhea experience in the past month	No	No	No	No	Yes
Final comments	Filter of different sizes will be good. Advertisement.	Size is too small	Size is small	N/A	Size is small
Tamale	Interviewee 6	Interviewee 7	Interviewee 8	Interviewee 9	Interviewee 10
Occupation	N/A	N/A	N/A	N/A	N/A
Source Water	Pipe water	GWC	Tank water	Pipe water	Dugout
Drinking Water Quality Perception	Safe to drink	OK	Safe	OK	Not safe
First impression of prototype	Nice product	Easy to use	Simple product	Nice device	Good product
Similar product awareness	No	No	No	No	No
Most important features for a filter product	Ability to filter water	Health impact	Health	Health impact	Durability
Decision influence	All the above	Health	Health	Health	Health, cost and peers
Price range	GHC 40	GHC 30	GHC 35	GHC 40	GHC 20
Purchasing method	Shop	Door to door	Door to door	Door to door	Shop
# of family members	6	6	8	9	8
Diarrhea experience in the past month	No	No	No	No	Yes
Final comments	Make it bigger	N/A	N/A	Size is small	N/A

Kumasi	Interviewee 1	Interviewee 2	Interviewee 3	Interviewee 4	Interviewee 5
Occupation	1 st year geological engineering	4 th year geology	3 rd year computer science	4 th year building tech	3 rd year political science
Source Water	Pipe water	Pipe water	Pipe water + sachet water	Pipe water	Pipe water
Drinking Water Quality Perception	Not safe	Good	Safe	Not good, with taste	Pipe water not clean, sachet water OK
First impression of prototype	Safe but small	Very good	Good idea	Takes too long to filter	Good item
Similar product awareness	No	No	No	Yes	No
Most important features for a filter product	Ability to clean	Health impact	Health impact (should be of various size)	Health impact	Health impact
Decision influence	Friends and peers	Health professional	Family member	Family member	Family member and himself
Price range	GHC 30	GHC 40	GHC 40	GHC 40	GHC 40
Purchasing method	Shop	Door to door	Shop	Shop	Shop
# of family members	N/A	N/A	N/A	N/A	N/A
Diarrhea experience in the past month	No	No	No	No	No
Final comments	Tamale will be a good place to sell	5 hours is OK, size should be bigger	Accra, Kumasi will be OK for the price, not Tamale	Size is small	N/A
Kumasi	Interviewee 6	Interviewee 7	Interviewee 8	Interviewee 9	Interviewee 10
Occupation	Material science professor	3 rd year political science	2 nd year business	1 st year pre-engineering	School worker
Source Water	Pipe water	Pipe water + bottle	Pipe water + bottle	Pipe water	Pipe water
Drinking Water Quality Perception	Water has taste	Good	Good	OK	OK
First impression of prototype	Good, better to be transparent	Time to treat is OK	Size is small	Nice product	Size is small
Similar product awareness	Yes	No	No	Yes	No
Most important features for a	Health	Health	Health	Durability, health	Health impact

filter product					
Decision influence	Himself	Health professional	Peers	Health professional	Family member
Price range	GHC 30	GHC 30	GHC 30	GHC 25	GHC 30
Purchasing method	Shop, door to door	Door to door	Door to door	Shop	Shop
# of family members	N/A	N/A	N/A	N/A	N/A
Diarrhea experience in the past month	No	No	No	Yes	No
Final comments	15~30L is ideal, time to treat is fine	Need to promote the product, and increase public awareness	Should be of different sizes	Size is too small	Time to treat is OK, might consider transparent container

Appendix C: Product Assessment: Financial Analysis Spreadsheet

Super Tunsai	2015	2016	2017	2018	2019
Injection molding	(50,000)	-	-	-	-
Platic material	(2,000)	-	-	-	-
Shipping	(5,000)	-	-	-	-
Custom tax	(5,000)	-	-	-	-
Operating expenses	(20,000)	(21,600)	(23,328)	(25,194)	(27,210)
Cost of production	(13)	(14)	(15)	(17)	(18)
Price	30	32	35	38	41
Units sold	1,917	1,898	1,953	2,087	2,200
End of year balance	(49,794)	12,837	14,942	18,973	23,074
Initial investment required	(107,304)				
5 years profit	6,411				
ROI (5-year)	0.06				

C1 Common Interface	2015	2016	2017	2018	2019
Unit purchasing price	(15)	(16)	(17)	(19)	(20)
Shipping cost	(2)	(2)	(2)	(2)	(3)
Custom tax	(5)	(6)	(6)	(6)	(7)
Operating expenses	(20,000)	(21,600)	(23,328)	(25,194)	(27,210)
Price	30	32	35	38	41
Units sold	1,917	1,898	1,953	2,087	2,200
End of year balance	(4,856)	(5,406)	(5,167)	(4,051)	(2,934)
Initial investment requirement	(62,366)				
5 years profit	(18,207)				
ROI	-0.29				

Assumptions:

1. Inflation rate = 0.08
2. Industrial machinery custom tax = 10%
3. Finished products custom tax = 30%

Appendix D: FM Making Dimensions

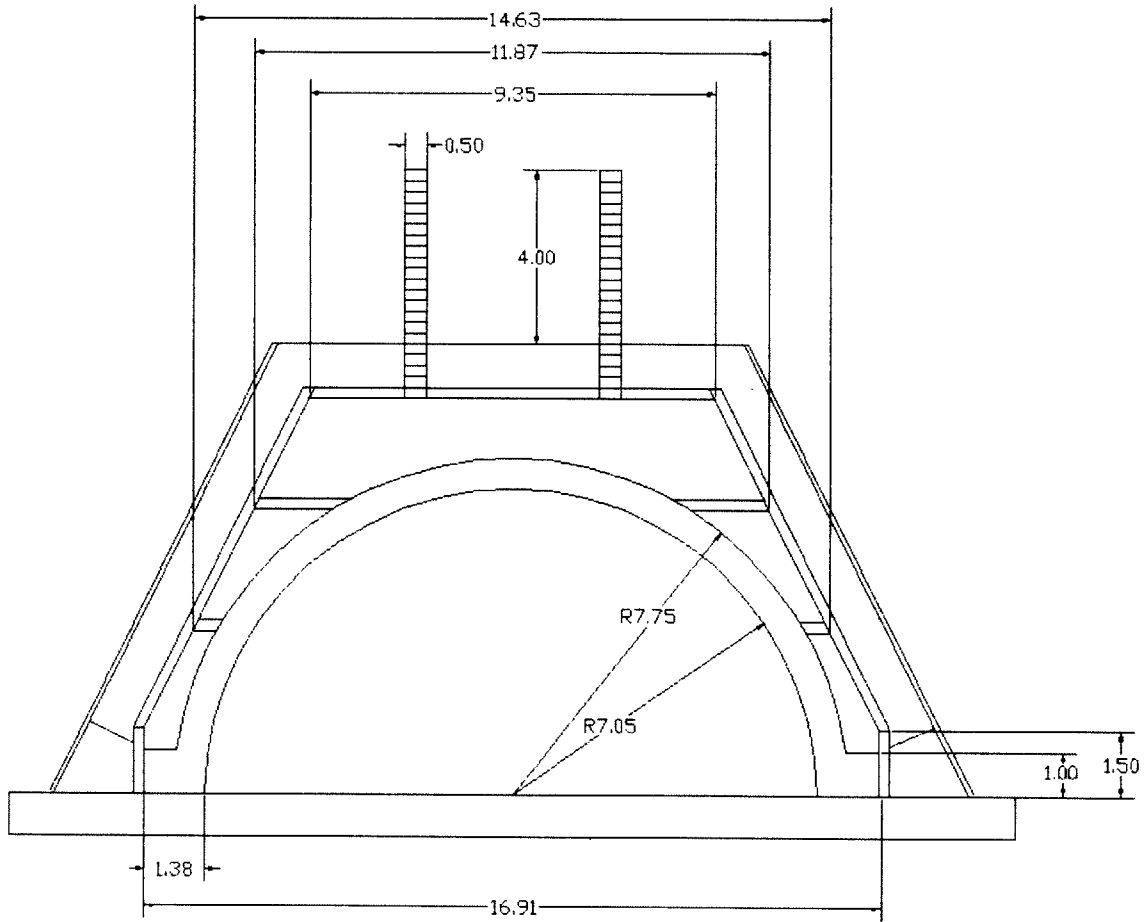

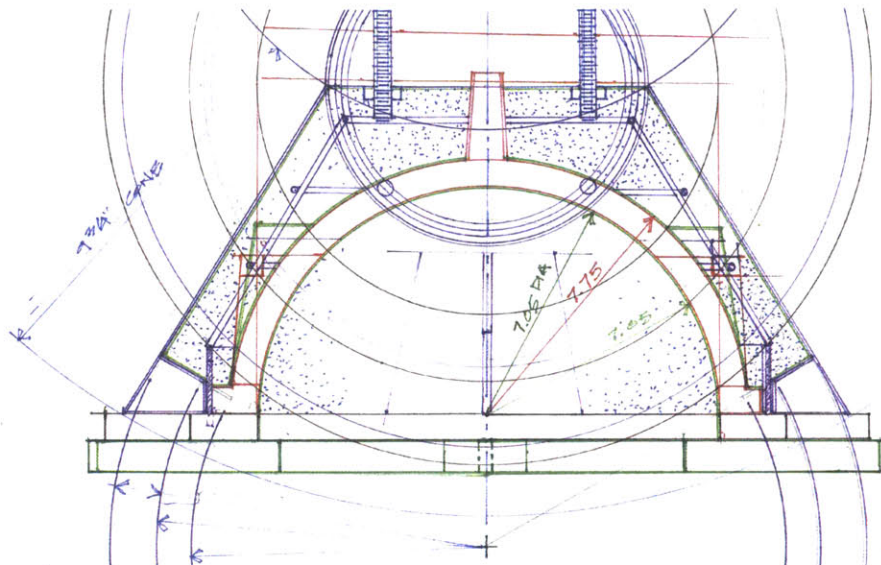

= DETAIL CASE ASSEMBLY FOR CASTING MOLD AND FOR CALENDING
 = SCALE $\frac{3}{8}'' = 1''$
 PEPE GARDNY HERRLINGS
 3-2013

Appendix E: Mold Making Material List

Mold making supply list (all items are sourced from lowes.com)					
Qty	Item	Item #	Model #	Unit Price US\$	Specification
1	Imperial 24-in x 36-in GV Flat Sheet	50186	GVL0108	9.24	Length = 36", Sheet Metal Gauge: 28
1	Top Choice 2 x 6 x 8 #2 Prime Pressure Treated Lumber	30906	TC268T225N	5.57	Actual thickness: 1- 1/2 inches, actual width: 5-1/2 inches, length: 96"
1	3/4 x 4 x 8 Pine Sheathing Plywood	202755	CCX34T25N	38.97	Actual thickness: 0.75", actual length: 96"
1	The Hillman Group 1/8- in x 36-in Threaded Rod	137900	880988	0.56	Length = 36", diameter = 0.138", threads per inch: 32
3	The Hillman Group 3- Count #1-8 Zinc-Plated Standard (SAE) Hex Nuts	436710	620	12.43	Nut diameter: #1, grade: all purpose, nut thread size: 8, tread type: fine, material: steel
1	Steel City 1/2-in Threaded Rod 10 Feet	44849	ZR1048	8.57	Length=120", diameter=0.5", threads per inch = 13
1	Project Pak 25-Count 1/2- in-13 Hot-Dipped Galvanized Standard (SAE)	41239	492021	8.98	Nut Diameter = 1/2", grade = all purpose, nut thread size = 13, thread type = coarse, material = steel

Item	Volume (or dimensions)	Units	Price (US\$)	Date of Price
Cement	50.00	kg	7	Jan-11
River Sand	9.48	m ³	75	Jan-11
Water	1000	L	25	Jan-11
Rice Husk	0.22	m ³	1.25	Jan-11
Clay Powder	1.00	m ³	232.5	Jan-11
Autobody Putty	25.3	Oz	24.99	May-13

Appendix F: Mold Making Tools Dimensions

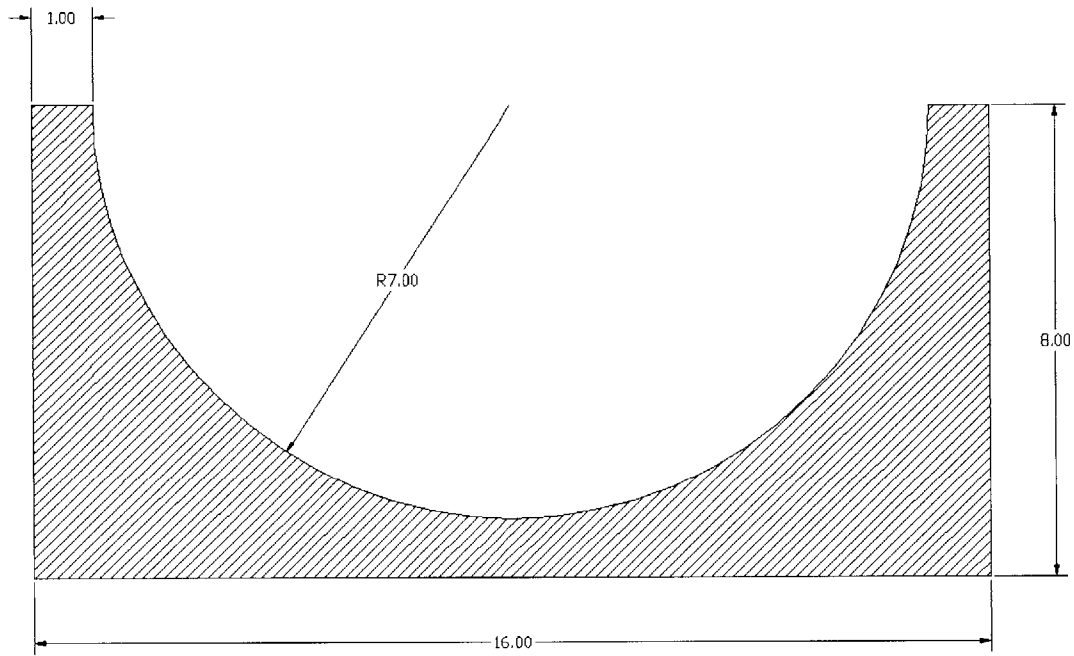

Figure 59: Male Mold Cavity AutoCAD Drawing (in inches)

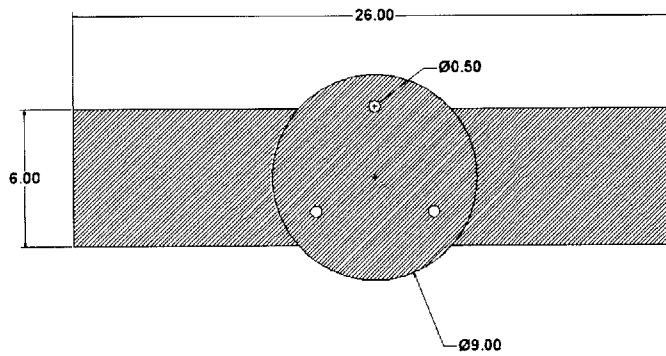

Figure 60: Wooden Template A AutoCAD Drawing (in inches)

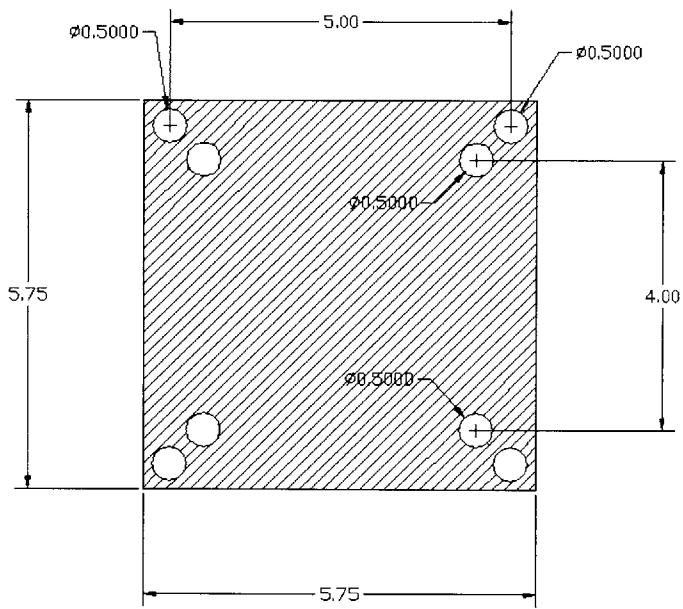

Figure 61: Wooden Template B AutoCAD Drawing (in inches)

Appendix G: Ghana Microfinance Institutions Information

Name	Website/Contact information
Opportunity International	http://www.opportunityghana.com
Vision Fund	http://www.visionfund.org/2088/where-we-work/africa/ghana/
CAsUD	http://www.casud.nl/site/home/
Mata Tudu, Konlan Lambonggang	jlambongang@yahoo.com
Grameen Ghana,	Musam03@yahoo.com
Mohamed GG	amohass@yahoo.com

Appendix H: Mold Making: Communication Records with Manny Hernandez

5/20/2013

How to make the tools for concrete mold making process.

1. How to make the sheet metal cone? dimensions?
See attachment of drawing



2. How to make Wooden Template A? Dimension?

This wooden template B was made to hold the threaded rod (which act as the mounting bolts) in place during the casting of the MM. The bolts will secure the MM onto its sliding platform/frame. The bolts are on a 6" diameter circle and 120 degrees apart from each other. As you can see, the disc is also divided into 90 degree quadrants. The disc is centered on the board and it suspends the wooden disc over the MM cavity. There is a line drawn with the marker on the center of the board which lines up with the line on the disc as shown in the photo. The board and disc are held in place over the MM cavity by placing bricks on the ends of the board.

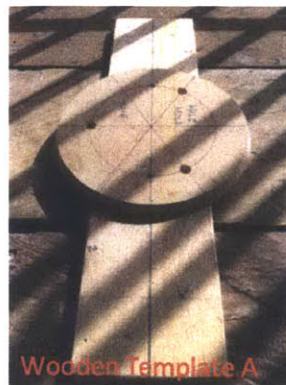

3. How to make Wooden Template B? Dimensions?

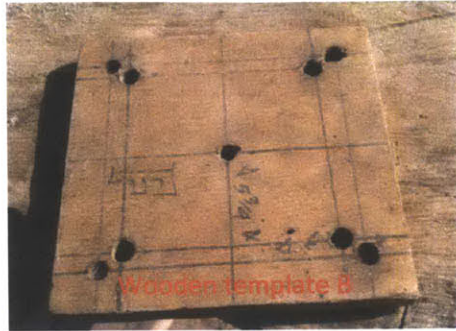

A piece of plywood was used to make wooden template B. This template is used to hold the threaded rod in their respective positions when they are welded to the top of the metal cage before casting the FM. The dimension for the 4 hole locations was derived from the mounting plates located on the top front and back of the Mani Press main frame. A tape measure was used to measure the dimensions from center to center side to side and front to rear. A 1 ½" space was measured parallel to the center lines of the holes to determine the edge of the plywood template. You don't have to put a dimension down since it is arbitrary when making another Mani Press; it could change.

4. How to make Item B?

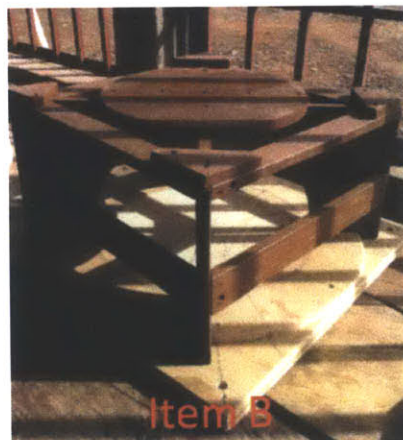

Item B is actually a jig of which there are 2 and they make both the male and female mold. It is made of 2 pieces of plywood that are about 11" high. They are egg crated in the center. They both have a notch ¾" (the thickness of plywood) by 2" deep. They slip over each other then are held together by the boards cut to size and support the pieces of plywood on top and along the sides. The disc on top is centered over the crossing point of the 2 pieces of plywood which are exactly 90 degrees apart. One jig has the cut out of the MM outer radius. The other jig has the cut out of the outer radius of the filter itself including the rim.

The space between the outer radius of the MM and the underside of the FM is $\frac{3}{4}$ ". Both jigs are notched at the bottom ends of the plywood and their dimension is 24" which means that each piece of plywood is about 26". The notches ride on the 24" disc that is attached and centered to the leveling platform. See photo above. The jigs rotate on the 24" disc which keeps them centered on the 24" wooden disc.

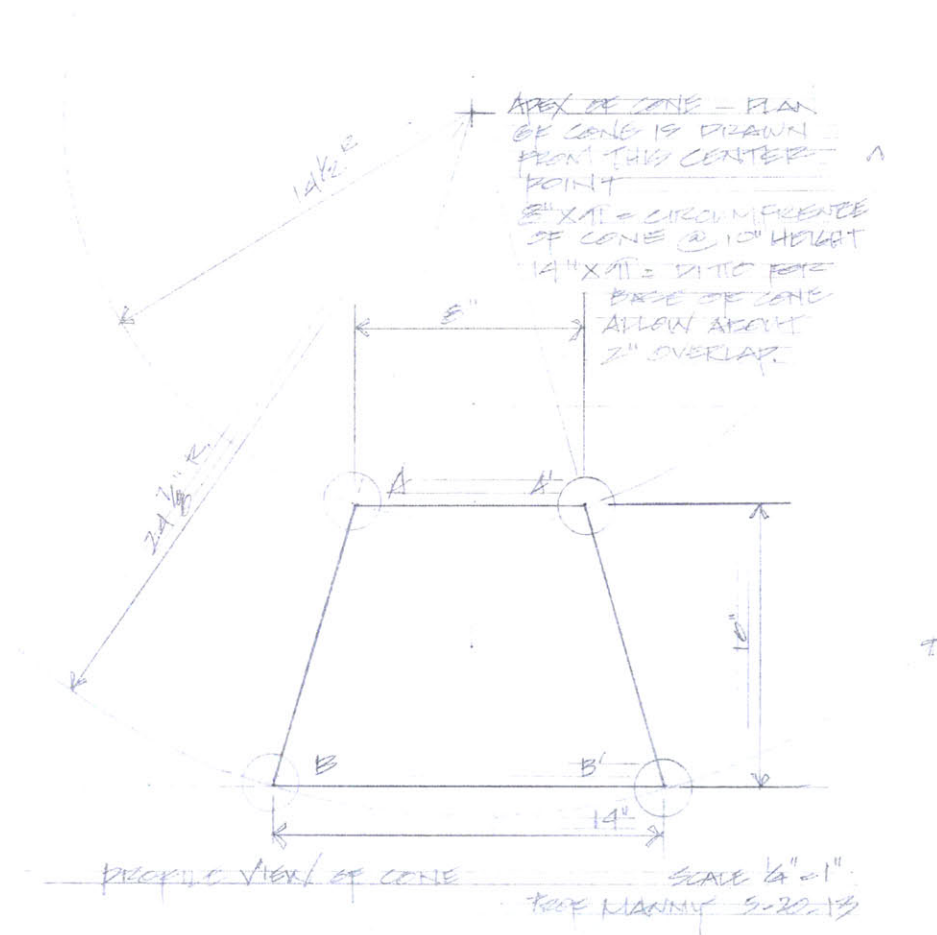

The author doesn't agree with the dimensions of the cone. Please compare it with the AutoCAD drawing in Appendix D.

5/17/2013

1. What is the distance between the two 1/2" threaded rods?

The distance between the mounting bolts is not set in stone. It happened that this new mold, that Susan refers to as the hemispheric shaped filter was made to replace the old mold that made the original parabolic shape filter. Since the new mold had to fit the mounting plate on the revised Mani Press the dimension between bolts had to match the hole openings on the MP.

2. How wide is the foldable metal, i.e. aluminum flashing?

Because I knew that couldn't purchase the aluminum flashing in Ghana or spend half my time there looking for it, I purchased and brought a roll of it with me. The roll was 18" wide by I can't remember what length it was. I had to use duck/duct tape to tape it together to make the cone shape that held the cement when the cement was pored into its cavity. For our purposes it worked perfectly and bends easily. Now if you are looking for the dimension between the bottom ring and the cone that isn't set in stone. I arrived at that dimension when I was laying out the drawing. I wanted the cone sides to be parallel to the sides of the metal cage around the FM set within it. So however it came out on the drawing that gave me the diameter of the base of the cone. The drawing has a scale written down as to what measurement I used. It's either 3/8", 1/2" or 3/4" equals an inch.

Hope that helps, if not, re-email me and I'll dig it up for you. I really don't think it is important because the shape of the cone can change depending on the redesign of the filter.

5/3/2013

Hola Susan,

I'm sending you 2 drawings I have that I made for use when we were making the PHW male and female cement molds. All the information is on the drawings for making the molds, the metal cage and the cones made from the aluminum flashing that I brought with me on my last trip. Keep in mind that the base ring diameter had to be made smaller to accomodate the new plastic lid, so the rim on the clay filters pressed after the molds were completed fired a bit smaller but perfect to fit the lid.

One of the drawings was used to figure out the ring sizes and other calculations. I'm probably the only one that understands the drawings.

Hopefully this will make it a little clearer for Shen. I edited his thesis quite a bit the 2 times that he returned it to me. I made quite a bit of comments but I think it will be a little better understood by a lay person reading it, at least I hope so.

If you have any coments, please e-mail me. Can you copy this to Shen for me.

What's the latest from the factory. They must have the roof up by now. When do the rains commence?

Prof Manny

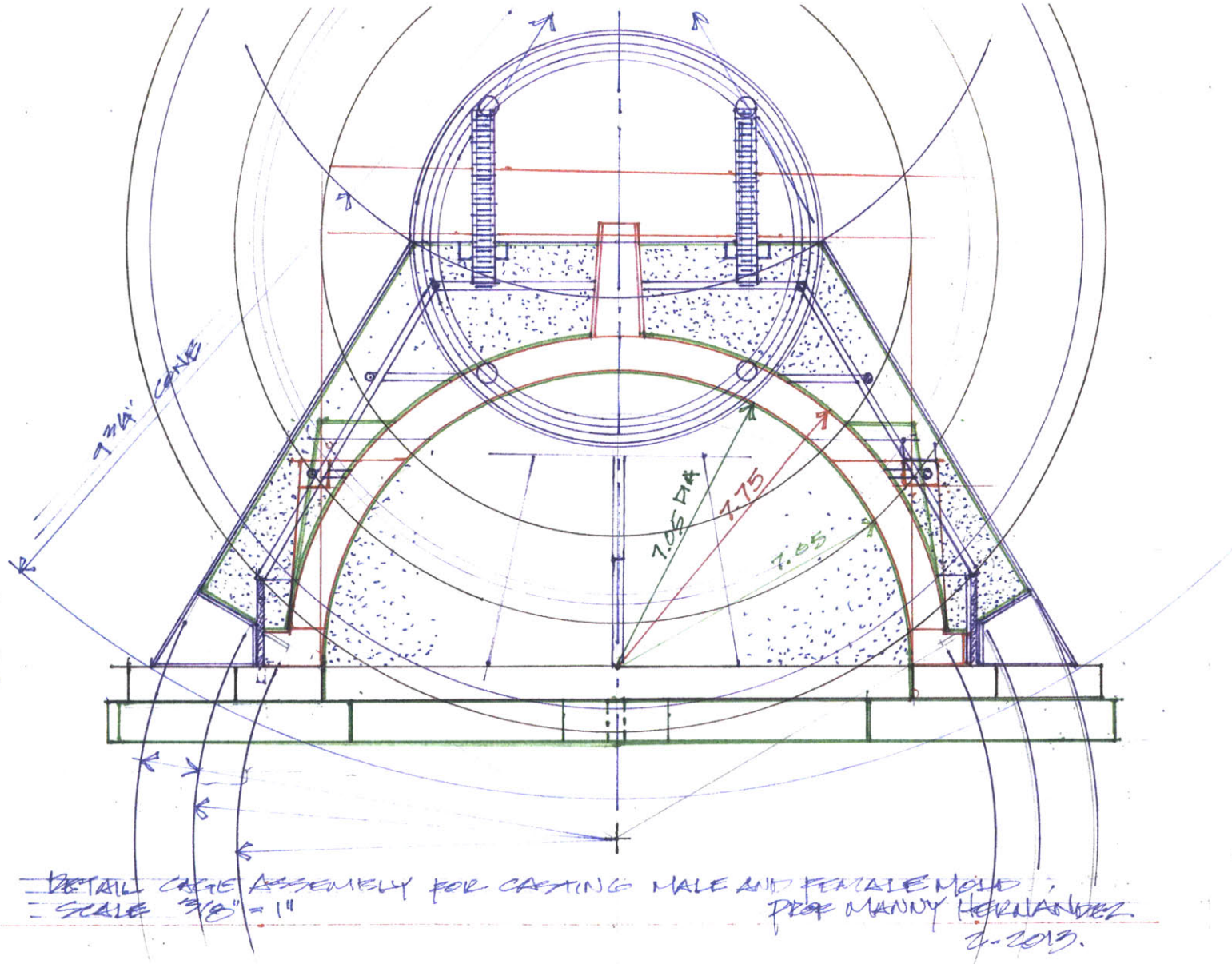

5/2/2013

