

Wireless Sensor Network for Ground-Water Monitoring  
By  
Raghu B Narayan

B.E. Civil Engineering  
Bangalore University, 1999

Submitted to the Department of Civil and Environmental Engineering in  
partial fulfillment of the requirements for the Degree of

MASTER OF ENGINEERING IN  
CIVIL AND ENVIRONMENTAL ENGINEERING

AT THE  
MASSACHUSETTS INSTITUTE OF TECHNOLOGY

JUNE 2002

© 2002 Raghu B. Narayan. All rights reserved

The author hereby grants to MIT permission to reproduce and to distribute publicly  
paper and electronic copies of this thesis document in whole or in part.

Author.....  
Raghu B Narayan  
Department of Civil and Environmental Engineering  
May 13, 2001

Certified.....  
Kevin Amaratunga  
Assistant Professor, Civil and Environmental Engineering

Accepted by .....  
Oral Buyukozturk  
Chairman, Departmental Committee in Graduate Studies

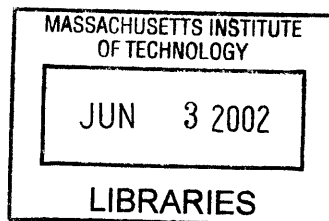

BARKER

# Wireless Sensor Network for Ground-Water Monitoring

By

Raghu Narayan

Submitted to the Department of Civil and Environmental Engineering  
on May 24, 2002 in Partial Fulfillment of the  
Requirements for the Degree of Master Of Engineering  
in Civil and Environmental Engineering

## Abstract:

Environmental issues have become of prime concern in the recent past due to a dramatic increase in the pollution levels in all parts of the world. Therefore, environmental data monitoring and real time data analysis are the key challenges faced by the industry. Information technology enables us to integrate systems for constant data acquisition and analysis. The ultimate goal of this project is to apply sensor technology integrated with wireless network for ground water monitoring without human assistance.

This project is also intended as an educational visualization tool for the undergrad Environmental courses.

The 'Smartwells Project' is an attempt to build such a monitoring system in a laboratory environment. The second stage of the project would include real time deployment in the field. The sensors used were conductivity sensor and water level sensor to measure the conductivity properties and the water level in the Plexiglas prototype wells. A tipping bucket rain gauge was also included in the setup to measure the precipitation at the place.

New sensor technologies like the advances in the field of MEMS (Micro-Electro-Mechanical Systems) have given ample opportunities for future research. The various new wireless communication technologies like Blue Tooth etc must be examined for the above system to become more efficient and independent.

Thesis Supervisor: Kevin Amaratunga

Title: Assistant Professor of Civil and Environmental Engineering

## Acknowledgements

I would like to dedicate this thesis to my Family who provided the inspiration and encouragement for me to come to M.I.T. I would like to make a special mention of my brother whose constant support helped me in successful completion of the course.

To Prof . Kevin Amaratunga and fellow M.S. student Rangunathan Sudarshan , the Smartwells project would never have made it so far.

To Ashish Kulkarni, fellow partner in the Smartwells Project, it was wonderful working with you.

To all the M.eng students in the Information Technology Track, it was a pleasure working with all of you.

Finally, I would like to thank God for blessing me with the opportunity of pursuing my education this far.

# Table of Contents

<b>Table of contents.....</b>	<b>4</b>
<b>List of Figures.....</b>	<b>6</b>
<b>List of Tables .....</b>	<b>8</b>
<b>1 Introduction.....</b>	<b>9</b>
<b>1.1 Motivation.....</b>	<b>9</b>
<b>1.2 Road Map of the Thesis .....</b>	<b>10</b>
<b>2 Smartwells Project.....</b>	<b>11</b>
<b>2.1 Project Overview .....</b>	<b>11</b>
<b>2.2 System Architecture .....</b>	<b>15</b>
<b>3 Sensors.....</b>	<b>26</b>
<b>3.1 Introduction.....</b>	<b>26</b>
<b>3.2 Conductivity sensor.....</b>	<b>27</b>
<b>3.3 Water Level Sensor.....</b>	<b>33</b>
<b>3.4 Rain Gauge .....</b>	<b>37</b>
<b>3.5 Implementation of the Sensors.....</b>	<b>39</b>

<b>4. Wireless Networks.....</b>	<b>40</b>
<b>4.1 Introduction.....</b>	<b>40</b>
<b>4.2 Working of Wireless LAN.....</b>	<b>41</b>
<b>4.3 Classification of Wireless LAN.....</b>	<b>44</b>
<b>4.4 Wireless LAN standards.....</b>	<b>53</b>
<b>4.5 802.11 Vs Bluetooth.....</b>	<b>68</b>
<b>5. Deployment at Waquoit Bay.....</b>	<b>70</b>
<b>5.1 Overview .....</b>	<b>70</b>
<b>5.2 Site Conditions.....</b>	<b>70</b>
<b>5.3 Proposed Plan of Implementation.....</b>	<b>71</b>
<b>6. Conclusions.....</b>	<b>74</b>
<b>References.....</b>	<b>76</b>

## List of Figures

<b>2.1 Smartwells Laboratory set-up.....</b>	<b>12</b>
<b>2.2 Parsons Lab.....</b>	<b>13</b>
<b>2.3 Waquoit Bay Reserve, Cape Cod.....</b>	<b>14</b>
<b>2.4 System Architecture of Smartwells Project.....</b>	<b>15</b>
<b>2.5 Complete Fieldpoint Data Acquisition System.....</b>	<b>17</b>
<b>2.6 FP-AI_110 I/O module.....</b>	<b>17</b>
<b>2.7 FP-1600 Network Module –NI.....</b>	<b>18</b>
<b>2.8 Residential Gateway.....</b>	<b>20</b>
<b>2.9 Ethernet and Serial Converter.....</b>	<b>21</b>
<b>2.10 Water level monitoring applet.....</b>	<b>22</b>
<b>2.11 Gradient in well properties.....</b>	<b>23</b>
<b>2.12 Archived data of conductivity properties and water level changes.....</b>	<b>24</b>
<b>2.13 Charts and Bar-graphs showing Conductivity and water level properties</b>	<b>24</b>
<b>3.1 Conductivity Sensor.....</b>	<b>28</b>
<b>3.2 Electrode Method.....</b>	<b>31</b>
<b>3.3 Transformer Method.....</b>	<b>33</b>
<b>3.4 Water-level Sensor.....</b>	<b>34</b>
<b>3.5 Pressure Transducer.....</b>	<b>35</b>
<b>3.6 Silicon Diaphragm.....</b>	<b>36</b>
<b>3.7 Circuit diagram.....</b>	<b>36</b>
<b>3.8 Rain Gauge.....</b>	<b>37</b>

<b>3.9 Tipping bucket mechanism.....</b>	<b>39</b>
<b>4.1 Communication Systems Engineering.....</b>	<b>45</b>
<b>4.2 DSSS (Direct Sequence Spread Spectrum).....</b>	<b>47</b>
<b>4.3 Signal analysis at transmitter.....</b>	<b>47</b>
<b>4.4 Bandwidth at respective signals.....</b>	<b>48</b>
<b>4.5 FHSS system.....</b>	<b>51</b>
<b>4.6 Architecture of wireless LAN .....</b>	<b>54</b>
<b>4.7 IEEE 802.11 layer description.....</b>	<b>55</b>
<b>4.8 RTS/CTS transaction between two stations.....</b>	<b>59</b>
<b>4.9 Process of large packets being broken in to smaller ones.....</b>	<b>60</b>
<b>4.10 Bluetooth layers.....</b>	<b>65</b>
<b>4.11 Piconet.....</b>	<b>67</b>
<b>4.12 Scatternet.....</b>	<b>68</b>
<b>5.1 Waquoit beach.....</b>	<b>72</b>
<b>5.2 Waquoit bay reserve research office.....</b>	<b>73</b>

## List of Tables

<b>2.1 Specification of FP-AI_110 I/O module.....</b>	<b>18</b>
<b>2.2 Specification of FP-1600 Network module.....</b>	<b>19</b>
<b>2.3 Specification of Residential Gateway.....</b>	<b>20</b>
<b>2.4 Specification of Ethernet and Serial converter.....</b>	<b>21</b>
<b>3.1 Specification of Conductivity sensor.....</b>	<b>29</b>
<b>3.2 Specification of Water level sensor.....</b>	<b>35</b>
<b>3.3 Specification of Rain Gauge.....</b>	<b>38</b>
<b>4.1 Frequency ranges.....</b>	<b>43</b>
<b>4.2 Specification of DSSS IEEE 802.11 wireless LAN.....</b>	<b>63</b>
<b>4.3 Specification of FHSS IEEE 802.11 wireless LAN.....</b>	<b>64</b>
<b>4.4 Bluetooth stack layers.....</b>	<b>66</b>
<b>4.5 Specification of Bluetooth.....</b>	<b>66</b>



# **1 Introduction**

The purpose of this thesis is to analyze and examine the applications of sensors and wireless networks for the real time data transfer and monitoring in environmental studies. The project to be discussed is a Masters Research initiative in the department of Civil and Environmental Engineering at the Massachusetts Institute of Technology (MIT) in Cambridge, Massachusetts. The project is named 'Smartwells', in tune with the fact that the project involves monitoring of underground wells. The wells are stationed outside the Parsons lab building. This project was created through the funding of Microsoft's I-campus program. This project involves 2 members and a faculty advisor, Prof Kevin Amaratunga.

This thesis will mainly focus on the sensors that are currently being used on the smart wells project – conductivity probes, water level loggers and rain gauges. It will discuss different components of each sensor and describe their governing physical principles. Recent advancements in sensor wireless communication are also covered.

## **1.1 Motivation**

With the advances in the modern day science it becomes imperative not only to save the environment from getting polluted but also monitor it. Water plays an important role in our daily lives. Ground water flow has to be monitored for the following reasons:

1. Characterize waters and identify changes in water quality over time.
2. Gather Information of various data regarding the change in water levels during various seasons.
3. Identify specific existing or emerging water quality problems.
4. Characterize and define trends in the physical, chemical and biological condition of the environment.

Visual aids have always been a helpful proposition in education. Books are filled with various pictures and graphs to make the subject not only interesting but also comprehensible.

'Smartwells' is an attempt to enhance the present education system by providing visual aids to comprehend the data analysis and various experiments in a better manner.

## **1.2 Roadmap of the Thesis**

This thesis is organized as follows. Chapter2 discusses the overview of the project. It delves in to details of the system architecture describing the specifications of various hardware and also describing the various software tools developed during the course of the project. Chapter 3 focuses on the various types of sensors used in this project. The various principles and theories behind the sensors are described in this chapter. Chapter 4 describes the Wireless Network used in the project .It describes new emerging wireless standards. Chapter 5 describes a proposal for additional enhancements in the project. Chapter 6 is the conclusion from the above project.

## 2 Smartwells Project

### 2.1 Project Overview

This thesis will include specifics of various technologies used in the Smart Wells Project administered by Civil Engineering Department at Massachusetts Institute of Technology (MIT). The Smartwells Project is an attempt to monitor the data real-time in an underlying aquifer. The project is divided in to three stages.

1. Laboratory Prototype
2. Deployment outside the Parsons Lab
3. Deployment at a Real-Field site (Waquoit Bay Reserve – Cape Cod)

#### 1. Laboratory Prototype:

The following figure shows the Laboratory set-up of the ‘Smartwells Project’. The prototype is set-up in room 1-131 (Design studio of the future) in building 1 at MIT. The laboratory set-up was a test-bed for the various sensors used such as the conductivity sensor, water-level sensor and rain gauge. Two Hydraulic Plexiglas cylinders of diameter 15cms and height 75cms were constructed to emulate the wells. The Field point data acquisition system made by National Instruments is used to convert the analog signals from the sensors to the digital signals and transmit the digitized data to the data server. The wireless set-up is configured to wirelessly transmit the data to the data server. The same machine i.e. <http://smartwells.mit.edu> acts as an

application server as well as a web server. Laboratory set-up would give necessary inputs for the feasibility of this project and for further real-time deployment.

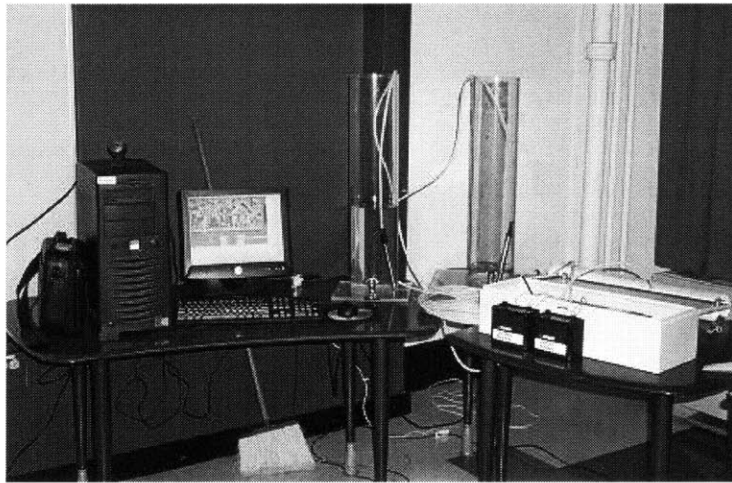

Fig 2.1 Smartwells Laboratory set-up (room 1-131)

## 2. Deployment outside Parsons Lab

Parsons lab is the Environmental Engineering building of MIT. There are three wells present in the parking lot at the side of the building. The Prototype as described in the previous page would be set up in this building to monitor the aquifer underlying the building. The deployment at this stage would involve installation of the water level and conductivity sensors in to wells and the rain gauges on the roof of the building. The Wireless set-up was decided to be temporarily installed in the third floor copier room of the building and the Field Point Data Acquisition

module in the first floor lab adjoining the parking lot. The new IP addresses of the building would be configured for the wireless set-up and the server. This stage had to be deployed by June 2002. Due to construction going on at the Parsons lab, the wells were dug up. Hence this stage of the project is postponed to a further unscheduled date.

The deployment of the project at this stage will be used as an Educational aid to the Environmental Courses offered by the Civil Engineering Department. Experiments such as the Salting Tests, Tracer tests etc can be conducted from the numerous data archived.

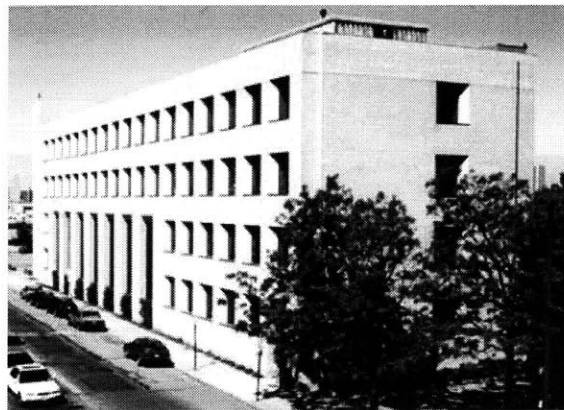

Fig 2.2 Parsons Lab, (Building 48, MIT)

### 3. Real time Deployment at Waquoit Bay Reserve

The Waquoit Bay National Research Reserve (WBNERR) is located on the south shore of Cape Cod, Massachusetts in the towns of Falmouth and Mashpee. It encompasses some 3000 acres of open waters, barrier beaches, marshlands and uplands. It is around 78 miles from MIT, Cambridge. The ocean waters bring in dynamic changes in the water levels and the salinity in water. The water levels change depending on the seasons and tides. The changes in the conductivity can be addressed due to the mixing of fresh water and the seawater.

Chapter 5 goes in to further details of the implementation of the Smartwells project at the reserve and further enhancements to accommodate the various researches done at Waquoit Bay.



Fig 2.3 Waquoit Bay reserve, Cape Cod, Massachusetts

## 2.2 System Architecture

The entire system of Smartwells can be broadly subdivided in to three parts.

1. Sensors and Data Acquisition system
2. Data Transmission and Storage
3. Visualization tools for Research and Educational Aid

The following figure shows the system architecture of the Smartwells project.

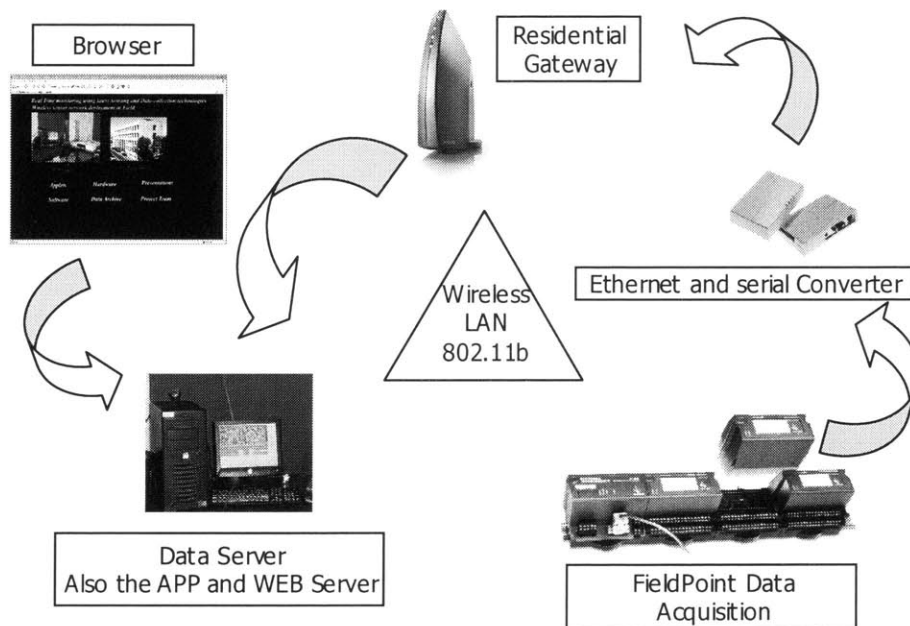

Fig 2.4 System Architecture of Smartwells Project

### 1. Sensors and Data Acquisition System

Water undergoes numerous changes along its course of travel from its origin (i.e. glaciers or rain water) till it meets its destination (i.e. sea or ocean). During its course of travel, the same water is

used for various domestic purposes like drinking, bathing etc. In this project we monitor the changes in water-conditions using various sensor technologies.

We monitor three properties of ground water in this project i.e. the conductivity of water, water level of ground water and the rate of precipitation. We mounted three types of sensors on our system: the conductivity sensor, the water-level sensor and the rain gauge. After looking in to various factors such as compatibility to our data acquisition system, price etc, we selected the sensors from Global Waters, an environmental sensor manufacturing company situated in California. The chapter on sensors (chapter 3) goes in to further details of the principles and specifications of chosen sensors.

#### Data Acquisition System:

The Data Acquisition system is a device that collects the data points given as an output by the sensors. ‘Smartwells’ project utilized the system made by National Instruments called the Fieldpoint. The FieldPoint system is a modular distributed I/O system with Industrial-grade performance. It allows easy software integration and is one of the cost-effective instruments available in the market. With FieldPoint we can easily configure, build and maintain reliable distributed I/O solutions. The FieldPoint system includes a variety of isolated analog and digital I/O modules, terminal bases, and network interfaces for easy connection to open, standard networking technologies.



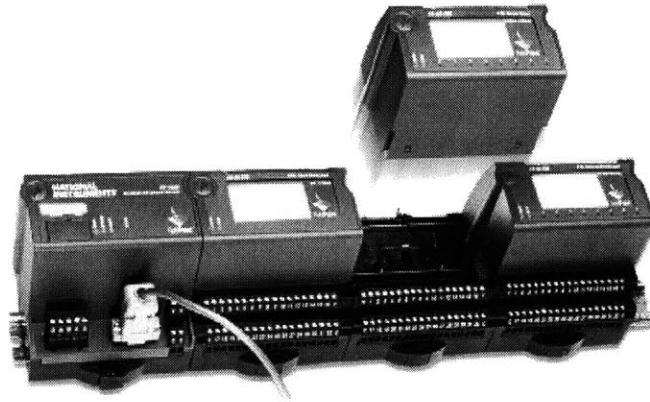

Fig 2.5 Complete FieldPoint Data Acquisition System – National Instruments

I/O module:

The FieldPoint system includes two general types of I/O modules. They are standard 8-channel and 16- channel modules and dual-channel modules for maximum mix and match flexibility. The FP-AI-110 can be used with both voltage and current input signals

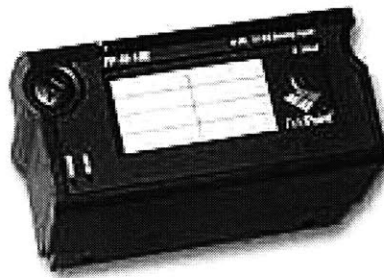

Fig 2.6 FP-AI\_110 I/O Module – National Instruments

Specification:

Number of channels	8 Nos
ADC Resolution	16 bits
Type of ADC	Delta-Sigma
Safety isolation, working voltage	250 Vrms, designed per IEC 1010 as double

Table 2.1 Specification of FP-AI\_110 I/O module

Network Module:

Network Modules provide connectivity to open, industrial networks. The network modules communicate with the local I/O module via the high-speed local bus formed by linked terminal bases. The FP-1600 network interface module used connects a node of up to nine FieldPoint I/O modules to a Ethernet network. It provides up to 100Mb/s data transfer rate.



Fig 2.7 FP-1600 Network Module – National Instruments

Specification of the Network Module:

Network Interface	10BaseT and 100BaseTX Ethernet
Compatibility	IEEE802.3
Communication Rate	10Mbps, 100Mbps, autonegotiated
Power Supply Range	11 to 30 VDC
Weight	250g

Table 2.2 Specification of FP-1600 Network module

2. Data Transmission and Storage:

The next part of the system involves wireless transmission of the data to the data server over the Ethernet wirelessly via the Wavelan and the Residential Gateway and storing it in a database. The Wavelan/Residential Gateway uses 802.11.b protocol for the wireless transmission and reception of data. These devices use the 2.4-2.485 GHz spectrum for communication and enables data transfer of up to 11 Mb/s. The FieldPoint module and the host computer connected to individual wireless network cards communicate via a central router called the Residential Gateway. The Residential Gateway provides up to 150 m of roaming access in the straight line of sight. The Ethernet converter takes serial or Ethernet inputs and connects to a wireless network card. In our system the Ethernet converter transmits data wirelessly from the FieldPoint module. This wireless infrastructure was found to be quite feasible for the 'Smartwells Project '. The Ethernet converter and Residential Gateway are based on DSSS (Direct Sequence Spread

Spectrum) technology. The fourth chapter on Wireless LAN's gives further details on the specification of the wireless protocol selected for this project.

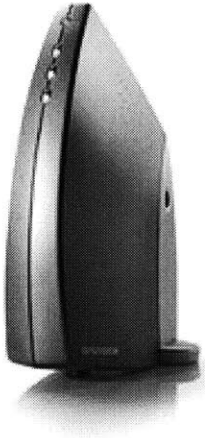

Fig 2.8 Residential Gateway

#### Specification of Residential Gateway

Compatibility	IEEE 802.11 Standard for high speed wireless LAN's
Bit error rate	Better than $10^5$
Range	Up to 550 meters
Frequency band/channels	2.4 Ghz
Encryption	64-bit wired equivalent privacy (WEP) based on RC4 algorithm

Table 2.3 Specification of Residential Gateway

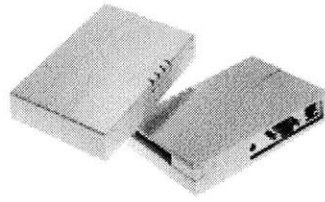

Fig 2.9 Ethernet and Serial Converter

Ethernet Interface	10Base-T (Unshielded Twisted Pair)
Serial Interface	RS-232-C 9-pin DB9 connector
Data Rate	10 Mbits/s
Input Voltage	5 VDC
Connector	Female RJ-45 (10Base-T)

Table 2.4 Specification of Ethernet and Serial Converter

A data server running LabWindows collects the data transmitted from the FieldPoint module.

LabWindows is a data collection and visualization software package created by National Instruments to interface with the FieldPoint module. The LabWindows software makes use of the CVI (c for virtual Instruments) programming language to collect and display data. Once the data server receives the data, a data socket is written so that other programs have access to it. Data sockets are similar to the normal sockets and are defined as temporary storage locations that package the data transmission and make it available to external computers. While the data is

constantly being streamed through on the data socket, a copy of that data is sent to a database and a web server, which resides on the same machine of the project.

### 3 Visualization tool for Research and Education

The third part of the system involves real-time visual display of data obtained. We have used both JAVA as well as .Net technologies in our project to build the software tools for Real-time display and Data archiving. The real-time data is displayed using applets, which subscribe to the DataSocket server to fetch real-time data. The archived data is rendered using applets which query the SQL Server database to extract data. The four visualization tools built are as follows.

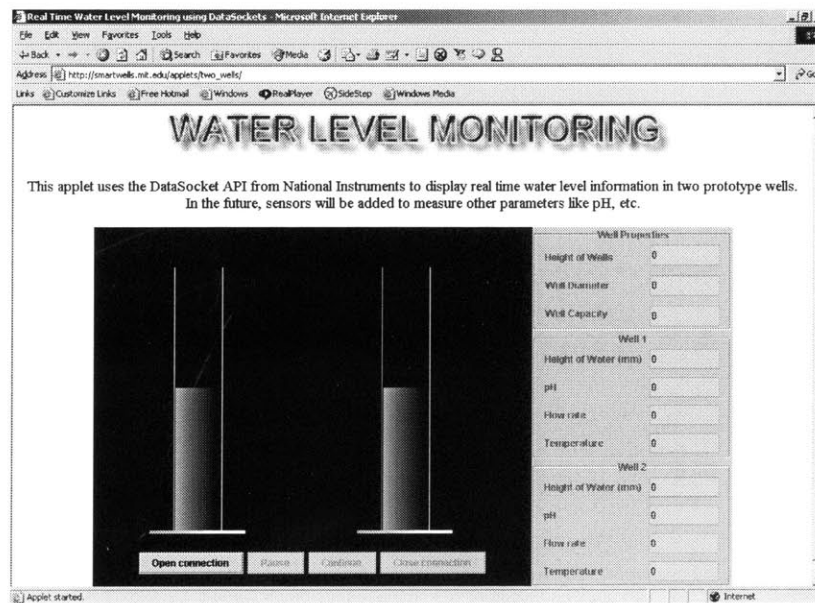

Fig 2.10 Water Level Monitoring applet

The Real-time water level monitoring applet displays real time water level data in two sample wells. The water displayed in the wells is colored blue. The water level in the applet changes in

real time with the actual change in the water levels of the concerned wells. The applets are configured such that zero water levels in the applet are for an actual 2-inch level in the well and full water level in the applet for a head of 30 inch in the well.

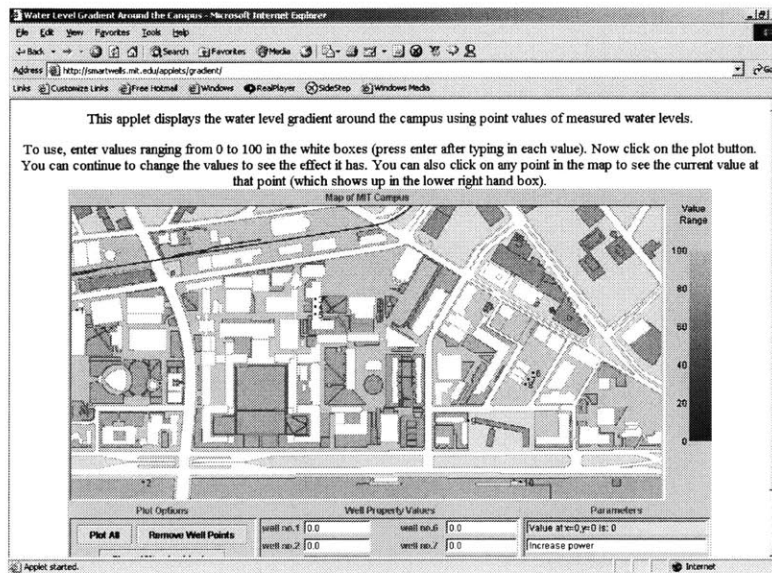

Fig 2.11 Gradient in well properties

This applet tool describes the water level gradient around the campus by using point values of water levels measured. The readings can be displayed in the textboxes and the points of measurement are plotted as well points. Water level gradient around the campus can also be plotted using 10% or 25% cut-off points from the points of measurement. The properties of the underlying aquifer at any point on the campus can be found out by inverse interpolation (using distances from the measurement spots) of well properties from the measurement spots

SMARTWELLS ARCHIVED LEVEL CONDUCTIVITY DATA

Refresh Conductivity Data      Refresh Level Data

InstantDate	Cond1	Cond2	InstantDate	Level1	Level2
1019710014363	0	0	1019710014363	0	0
1019710015364	0	0	1019710015364	0	0
1019710016366	0	0	1019710016366	0	0
1019710017367	0	0	1019710017367	0	0
1019710018369	0	0	1019710018369	0	0
1019710019360	0	0	1019710019360	0	0
1019710020362	0	0	1019710020362	0	0
1019710021363	0	0	1019710021363	0	0
1019710022365	0	0	1019710022365	0	0
1019710023366	0	0	1019710023366	0	0
1019710024367	0	0	1019710024367	0	0
1019710025359	0	0	1019710025359	0	0
1019710026360	0	0	1019710026360	0	0
1019710027362	0	0	1019710027362	0	0
1019710028363	0	0	1019710028363	0	0
1019710029365	0	0	1019710029365	0	0
1019710030366	0	0	1019710030366	0	0
1019710031367	0	0	1019710031367	0	0

Fig 2.12 Archived data of conductivity properties and water level changes

This software was built using Microsoft .Net web service. Archived data from the SQL database is extracted by using this tool. The archived data with respect to conductivity and water level changes of the two prototype wells is extracted using this tool.

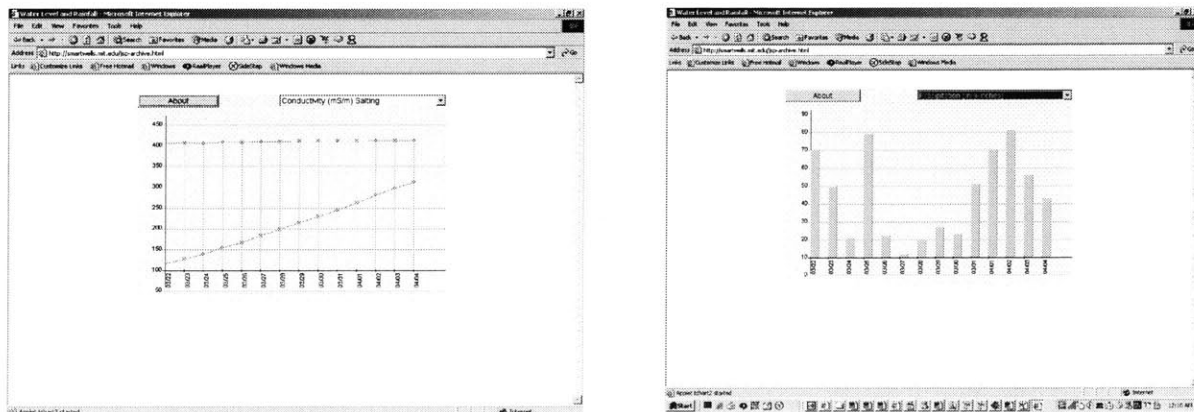

Fig 2.13 Charts and Bar graphs showing conductivity and water level properties



This applet plots charts for conductivity level and plots bars for rate of precipitation recorded. . The comparison charts for water level, conductivity and precipitation can also be seen in this applet.

This concludes the overall overview of the 'Smartwells Project'. From the perspective of the System Architecture, it is imperative for appropriate sensor technology and wireless standard to be used before the software tools are created. The following chapters delve in to various considerations involved in the selection of an appropriate sensor and a specific wireless protocol.

## 3. Sensors

### 3.1 Introduction

Sensors are a vast topic and widely used hardware components on a day-to-day basis. They involve concepts of physics, chemistry, biology and engineering, which are integrated, based on the applications. Sensors are used in various industries such as biomedical, military, space, industrial, environmental applications and are found to perform efficiently and accurately. A transducer is a device that converts energy from one domain in to another, calibrated to minimize the errors in the conversion process .A sensor is a basic element of a transducer and provides a useful output to the specified measured quantity. A more refined definition is “sensors are devices that have the ability to sense physical properties of the surrounding environment and return outputs that can be significantly interpreted. More simply, sensors input information into a system from the external world”(Brignell, 1994). An example of the above definition is the simple current sensors; here the current to be measured is converted to its proportional voltage, which can be easily interpreted by electronic circuitry.

Classification of sensors:

Sensors can be classified in the following manner:

1. Contact sensors: Sensors that have to touch the system to physically sense the quantity are called contact sensors

Ex: resistive current sensing

2. Non-contact sensors: Sensors that can detect or sense the quantity without touching the system physically are known as the non contact sensors.

Ex: Hall effect current sensing

3. Digital sensors: - These sensors provide digital output i.e. ones or zeros (on or off)

Ex: Direction sensors

4. Analog sensors or linear output sensors: - They provide more information about the sensed quantity .The output will be an analog quantity in the range from low to high.

Ex: Temperature sensors, which have output as current and are proportional to the increase in temperature

With the dawning of the wireless technology and IEEE 802.11, the sensors are made mobile and the data could be extracted in most inhuman conditions. In this module we will be examining sensors for the measurement of conductivity, water-level measurement and measurement of rate of precipitation.

The next few sections describe the sensors selected and their specifications with principles of operation for the Smartwells Project. The sensors included in the project are conductivity sensors, water-level sensors and rain gauge.

### **3.2 Conductivity sensors**

These sensors are used to find the conductivity (inverse of resistivity) of an aqueous solution.

The aqueous solution can be impure with impurities like salt, sand, chemicals etc thereby

changing its conductivity. Conductivity of the aqueous solution can be defined as the ability of the solution to carry electric current. Conductivity is calculated from the conductance measured by the sensor using a scale factor or "cell constant" that reflects the ratio of length and cross-sectional area of the sampled water volume in which the electrical current actually flows. Hence the exact accuracy cannot be obtained as it depends on the length/area ratio, which would be varying for different cells.

The following formula gives the value of conductance (inverse resistance)

$$C = 1/R \text{ where } (R = \rho l/A)$$

Here:

R = resistance = 1/conductance

$\rho$  = resistivity = 1/conductivity

L = length of sampled water volume

A = cross-sectional area of samples water volume

We are using the conductivity sensor WQ301 from the company Global Water.



Fig 3.1 Conductivity sensor

Specification of the Sensor Used:

1	Output	4-20 mA
2	Range	0 – 5 mS
3	Accuracy	±1%of full scale
4	Operating Voltage	12V DC
5	Current Draw	6.5mA plus sensor output
6	Warm Up Time	3 seconds minimum
7	Operating Temperature	-40 C to +55 C
8	Size of the Probe	1 in diameter and 10.5 in long
9	Weight	1 lb
10	Temperature Compensation	2% per C
11	Electrodes	316 Stainless Steel

Table 3.1 Specification of conductivity sensor

The conductivity sensor has three wires one each for the input voltage, ground and the output voltage. The sensor has 2 electrodes made of stainless steel and is able to measure the conductivity between them. The sensor is placed in the aqueous solution and the output of the sensor is proportional to the conductivity of the solution. This sensor could be used to measure the total conductivity of the aqueous solution or the total ion concentration of the aqueous

samples. Another important fact is that this sensor is temperature compensated by the presence of an internal thermister i.e. the sensor would give the same output for 15°C or 25°C so accuracy can be maintained even though there are changes in the temperature.

The conductivity calibration check is done on the sensor as below:

Fill one container with tap water and other with 5000 $\mu$ S (where  $\mu$ S is micro siemens) solution.

Place the conductivity sensor in the container filled with 5000 $\mu$ S solutions. Power supply is turned on and no reading is taken for 5 minutes before the system stabilizes. The output is taken as a value 'X'. The sensor is now rinsed off with tap water. Now the sensor is placed in a container with distilled water and the similarly reading as a value 'W' is taken. Again wait for 5 minutes before the readings are taken.

This output W is the value of the sensor when the conductivity is zero. The value X is maximum when the conductivity sensor is placed in 5000 $\mu$ S solution. Using these 2 values the system monitoring the conductivity readings could be recalibrated.

The calibrated conductivity readings can be obtained using the formula:

$$C = 5000 \frac{Y - W}{X - W} \mu S$$

Principle of operation:

The conductivity sensors manufactured by various companies follow one of the two general principles of operation.

1) Electrode method:

Electrodes are terminals through which current passes between metallic and nonmetallic parts of an electric circuit. In most familiar circuits metallic conductors carry current, but in some circuits the current passes through some distance through a nonmetallic conductor. Eg. In electrolysis current passes through a liquid electrolyte and in the above conductivity sensor it passes through the water medium. The electrode through which current passes from the metallic to the nonmetallic conductor is called the anode and that through which the current passes from the nonmetallic to the metallic conductor is called the cathode.

Simple electrodes are used in the model and the current is sent between the electrodes to measure the conductivity. A simple conductivity sensor using the electrodes is as shown below.

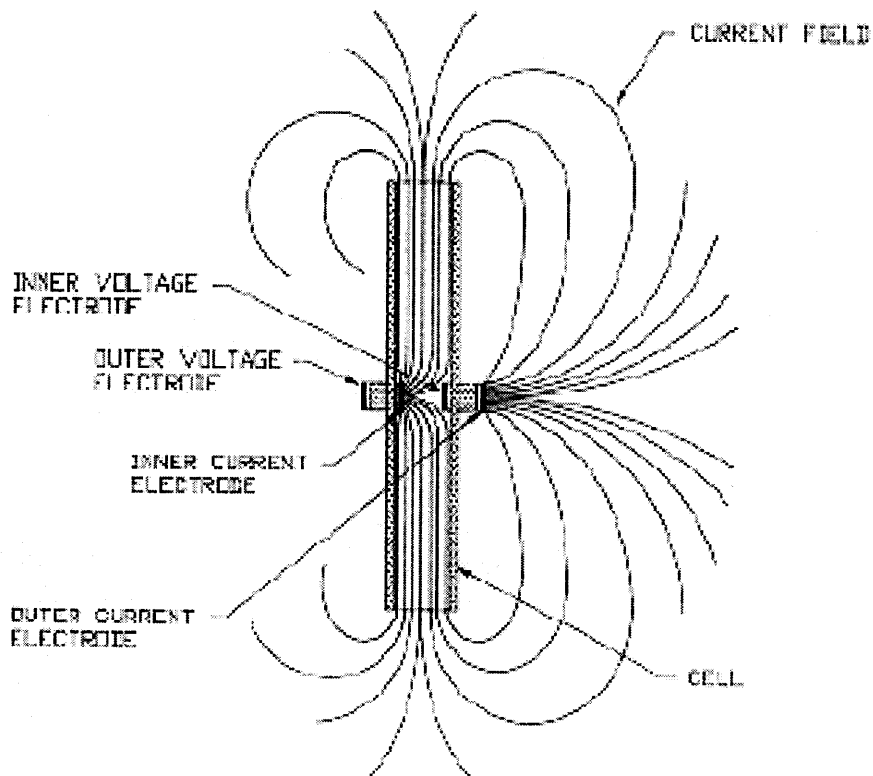

Fig3.2 Electrode method

The above figure shows the working of a conductivity sensor in the case of an electrode method. Electric current passes from an anode to the cathode of the electrode. The current measured at the cathode is the output of the sensor.

## 2) Transformer method:

A transformer is an electrical device used to transfer an alternating current or voltage from one electric circuit to another by means of electromagnetic induction. The simplest type of transformer consists of two coils of wire, electrically insulated from one another and arranged so that a change in current in one coil (the primary) will produce a change in voltage in the other (the secondary). Transformer cores are usually made of material with high magnetic permeability, which intensifies the magnetic field induced by the current in the primary increasing the transformers efficiency. Transformers are generally classified according to their uses. Power transformers are used to transmit power at constant frequency while audio transformers are designed to operate over a wide range of frequencies.

In the case of a conductivity sensor a transformer is used to couple a known voltage to the water and the resulting current flow in the secondary winding is detected. This approach is more complex as losses of the core and copper are to be taken in to consideration.



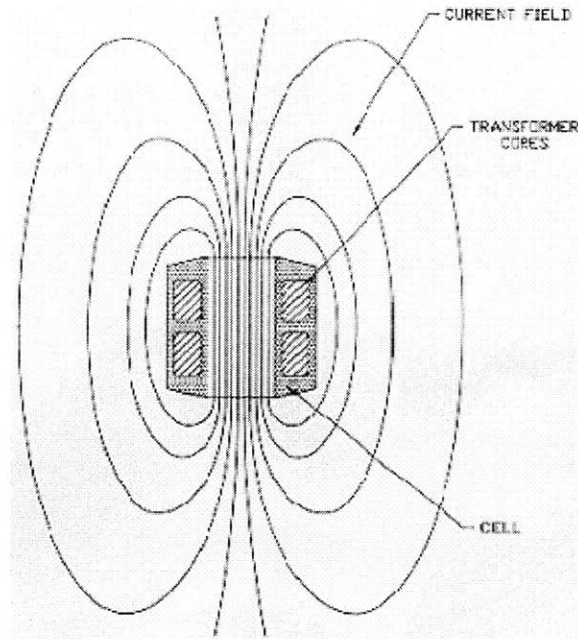

Fig3.3 Transformer method

Fig 3.3 shows the operation in the case of transformer method. Here the electric current flows through the hole in the transformers core. The field is denser near the transformer then away from it as shown in the figure. The secondary current is the output of the sensor.

Many companies have their own patented method of operation of conductivity sensor, however the above two methods are the basic principles used in conductivity sensors

### 3.3 Water-Level Sensors

These sensors are used to find the level of water in a submerged environment. The level of water is determined by the changes in the pressure of water due to the changes in volume. Global

Water's WL300 Water Level Sensor submersible pressure transducer consists of a solid state pressure sensor encapsulated in stainless steel submersible 3/4" diameter housing.



Fig 3.4 Water Level Sensor , Global Waters

Specification of the Sensor Used:

Pressure range	0-3', 0-15', 0-30', 0-60', 0-120', 0-250'
Linearity and Hysteresis	+/- 0.1% FS
Overall Accuracy	+/- 0.2% (35 F to 70 F)
Overpressure	X4
Burst Pressure	X10
Resolution	Infinitesimal
Outputs	4-20 mA 0 to 2.5 VDC across 125 ohms
Supply Voltage	10 to 36 VDC

Response Time	10 mS
Materials	Stainless Steel, Epoxy Silicon
Cable	Polyethylene jacket

Table 3.2 Specification of a water level sensor

Principle of Operation:

Transducer is an electronic device that converts energy from one form to the other.

The principle behind the working of a water level sensor is that of pressure transducing. A pressure transducer converts pressure changes sensed by a diaphragm in to either direct current or alternating current signals.

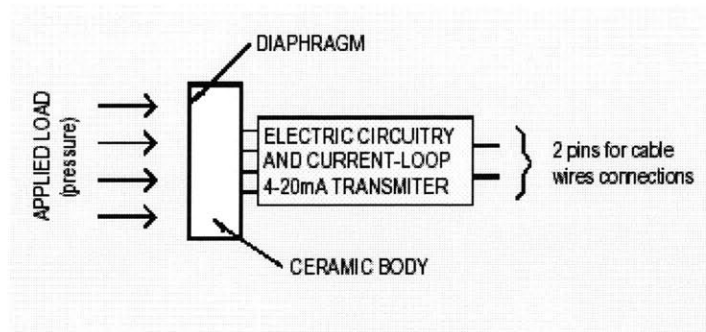

Fig 3.5 Pressure Transducer

The water level sensor consists of silicon as the pressure diaphragm. The pressure diaphragm is chemically inert with perfect mechanical characteristics. Screen printed resistors are deposited on to the diaphragm to form a 4 arm Wheatstone bridge. A fixed excitation voltage is applied to one diagonal of the Wheatstone bridge circuit.

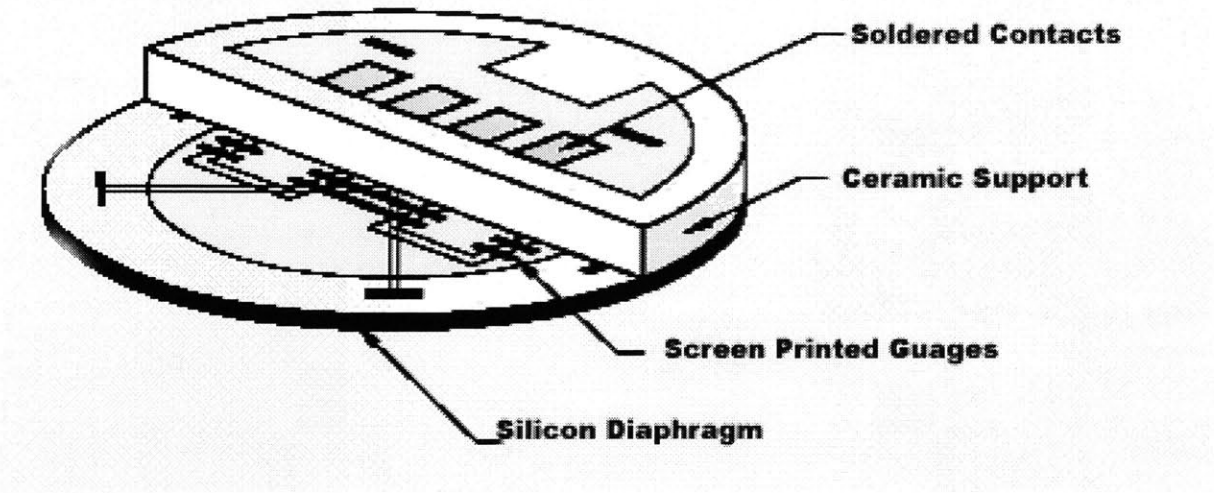

Fig 3.6 Silicon Diaphragm

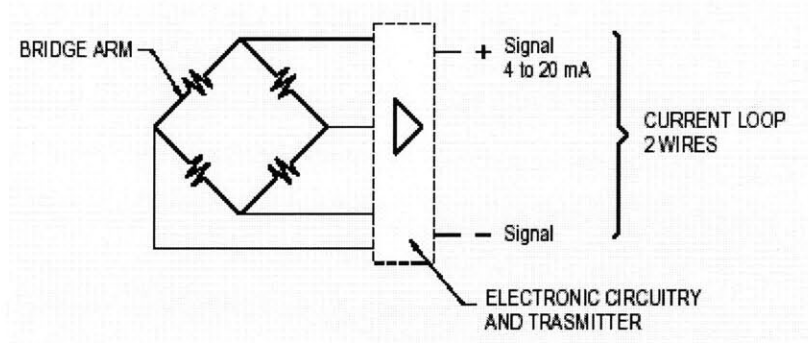

Fig 3.7 Circuit diagram

Strains experienced by the diaphragm will change the values of individual resistors within the Wheatstone bridge resulting in a bridge imbalance. This imbalance will result in an output signal from the other diagonal of the Wheatstone bridge, directly proportional to the applied stress. An electronic board converts this signal to 4-20mA output suitable for transmission for data acquisition systems.

### 3.4 Rain Gauge

These Sensors are used to find the precipitation rate (rain fall) at a given place. The sensors are usually placed on the rooftops or on open grounds which have clear and unobstructed mountings to collect the rainwater. We are using the Rain Gauge RG600 from the company Global Water.

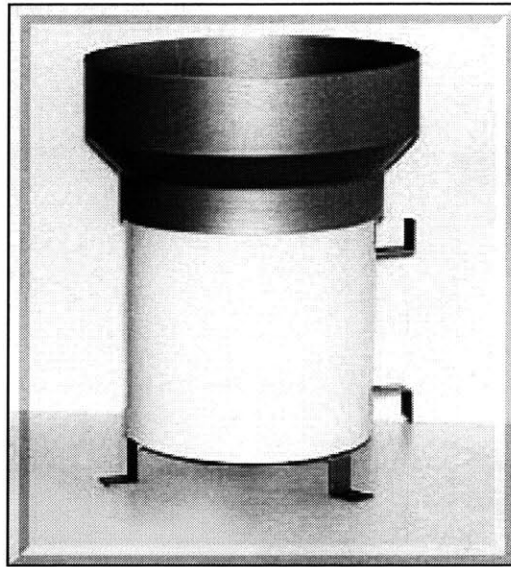

Fig 3.8 8" Rain Gauge, Global Water

#### Calibration:

The tipping bucket must be calibrated with the rate of flow of water through the tipping bucket mechanism. At least 36 seconds should be allowed to fill one side of the tipping bucket. This represents a maximum flow rate of one-inch rain per hour. During the first 50% of the tipping time, water continues to flow in to the filled bucket. The amount of water flowing during the first 50% of time is the error, the faster the flow rate the greater the error. At flow rates of one inch

per hour or less, the water actually drips in to the bucket rather than flowing. Under these conditions, the bucket tips between drips and there is no error in the readings.

Specification of the Sensor Used:

Capacity	Unlimited
Accuracy	3% up to 4"/hr ; 8% up to 6"/hr ,120VAC
Contact rating	3 watts, 28VAC, 0.25 amps
Dimension	8" × 15"
Funnel Diameter	8"
Shipping Weight	8 lbs
Cable	50' , 2 conductor

Table 3.3 Specification of Rain Gauge

Principle of Operation:

The sensor consists of a gold anodized aluminum collector funnel with a knife-edge that diverts the water to a tipping bucket mechanism. The bucket assembly has two compartments, each of which holds the selected increment of precipitation (0.2 mm of water or 1 inch of rainfall). The empty bucket assembly rests in one of two stable positions. As precipitation occurs, it is directed into one of the compartments, causing it to become heavier. When the correct amount of precipitation is collected the bucket tips in the opposite direction.

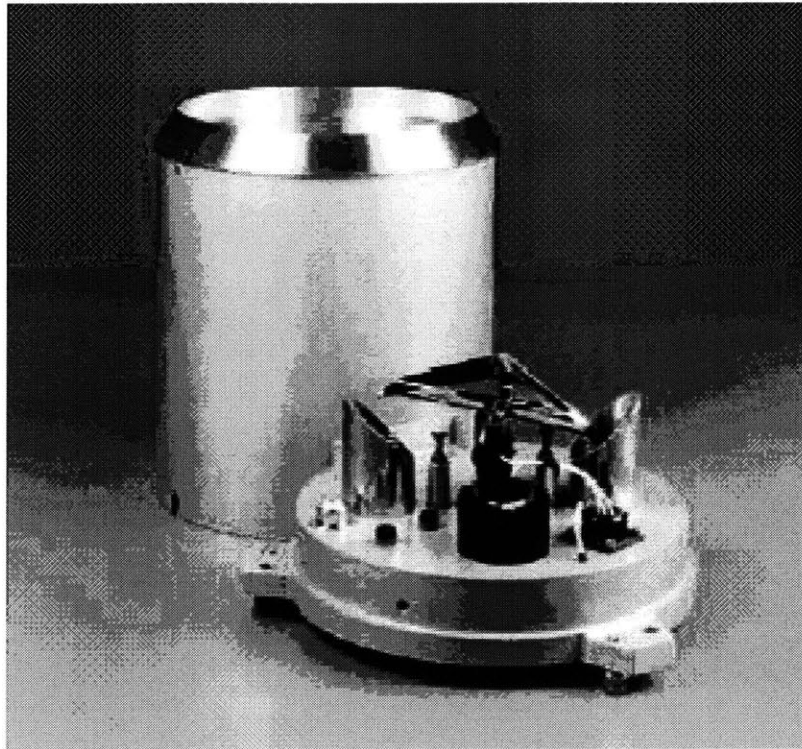

Fig 3.9 Tipping bucket mechanism

A magnet is attached to the tipping bucket that actuates a magnetic switch as the bucket tips. A momentary switch closure takes place with each tip of the bucket. The sensor is connected to an event/pulse counter on an electronic data logger or display module to record the accumulated rainfall.

### **3.5 Implementation of the Sensors**

The selected sensors are installed in the Plexiglas cylinders in the Lab prototype phase. In the second phase of the project i.e. implementation in front of the Parson's Lab, the sensors are installed in the selected wells. The third phase involves the sensors being installed in the Waquoit Bay beach for real time monitoring of sea water.

## 4. Wireless Networks

### 4.1 Introduction

A wireless LAN (WLAN) is a flexible data communication system implemented as an extension to or as an alternative for, a wired LAN within a building or campus. Using electromagnetic waves (radio and infrared), WLAN's transmit and receive data over the air, minimizing the need for wired connections.

#### **Need For a Wireless LAN:**

The widespread reliance on networking in business and the meteoric growth of the Internet and online services are strong testimonies to the benefits of shared data and shared resources.

Wireless LAN's offer the following advantages over the traditional wired networks, which make them preferable to wired LAN's

- **Mobility:** A wireless LAN system can provide LAN users with access to real-time information anywhere in their organization. This mobility supports productivity and service opportunities not possible with wired networks.
- **Installation speed and simplicity:** Installing a wireless LAN system can be fast and easy.
- **Installation Flexibility:** Wireless technology allows the network to go where wire cannot go.
- **Reduced cost of ownership:** The initial investment required for wireless LAN hardware can be higher than the cost of wired LAN hardware, but the overall installation expenses and life-cycle costs can be significantly lower.



- Scalability: Wireless LAN systems can be configured in a variety of topologies to meet the needs of specific applications and installations.

There have been various uses of the wireless LAN since its inception. Some of the many applications made possible through the wireless LANs are:

- Doctors and Nurses are more productive because hand-held with wireless LAN deliver patient information instantly.
- Warehouse workers use wireless LAN's to exchange information with central databases and increase their productivity.
- Senior executives in conference rooms make quicker decisions because they have real-time information at their fingertips.

## **4.2 Working of a Wireless LAN**

Wireless LANs use electromagnetic airwaves (radio or infrared) to communicate information from one point to another without relying on any physical connection. Radio waves are often referred to as radio carriers because they simply perform the function of delivering energy to a remote receiver. The data being transmitted is superimposed on the radio carrier so that it can be accurately extracted at the receiving end. This is generally referred to as modulation of the carrier by the information being transmitted. Once data is superimposed (modulated) onto the radio carrier, the radio signal occupies more than a single frequency, since the frequency or bit rate of the modulating information adds to the carrier.

Multiple radio carriers can exist in the same space at the same time without interfering with each other if the radio waves are transmitted on different radio frequencies. To extract data, a radio receiver tunes in one radio frequency while rejecting all other frequencies.

In a typical wireless LAN configuration, a transmitter/receiver (transceiver) device, called an access point, connects to the wired network from a fixed location using standard cabling. The access point receives, buffers, and transmits data between the wireless LAN and the wired network infrastructure in minimum time. A single access point can support a small group of users and can function within a range of less than one hundred to several hundred feet. The access point (or the antenna attached to the access point) is usually mounted high but may be mounted essentially anywhere as long as the desired radio coverage is obtained.

End users access the wireless LAN through wireless-LAN adapters, which are implemented as PC cards in notebook or palmtop computers, as cards in desktop computers, or integrated within hand-held computers. Wireless LAN adapters provide an interface between the client network operating system (NOS) and the airwaves via an antenna. The nature of the wireless connection is transparent to the NOS.

Wireless LAN's are typically designed to operate in the industrial, scientific, and medical (ISM) frequency bands because these bands are available for unlicensed operation and it is possible to build low-cost, low-power radios in this frequency range that operate at wireless LAN speeds. The following table shows the frequency ranges used in various countries.

Country	Frequency range(Ghz)	Available Bandwidth(Mhz)
United States, Most of Europe	2.400 to 2.4835	83.5
Japan	2.471 to 2.497	26
Spain	2.445 to 2.475	30
France	2.4465 to 2.4835	37

Table 4.1 Frequency Ranges

Constraints associated with a Wireless LAN:

**Path Loss:** The transmitted signal power normally radiates (spreads out) in all directions and attenuates quickly with distance. There is very little signal energy reaching the receiver, giving rise to a proportional relationship between distance and path loss.

**Multipath:** Multipath is a critical problem that can lead to intermittent network connectivity. The multipath phenomenon is caused by differently delayed versions of the original signal with a delay spread at the receiver. The delayed signals are produced by reflected signals arriving at the receiver along different paths, thus delaying in differing propagation delays. Reflections are generated when the propagating signal impinges on an object, which is large compared to its wavelength.

**Delay spread:** The delay spread is defined as the difference in propagation between the directed (line-of-sight) signal and the reflected signal that takes the longest path from the transmitter to

the receiver. The sum of two such modulated signals cancels or reinforces each other depending on the difference in their phase angles.

### **4.3 Classification of wireless LAN's**

Wireless LAN's can be broadly classified under radio or infrared LAN's. Radio LAN's can be based on narrowband or spread spectrum transmission while infrared LAN's can be diffuse or directed. We will focus on radio LAN's in this chapter with more emphasis on spread spectrum transmission.

Spread spectrum communication systems are widely used technology. They find their applications in both military and commercial field. The use of the spread spectrum communication systems in digital communications has the following advantages:

- a) Resistance to jamming.
- b) Hide the signal from an unintended user.
- c) Providing reliable communications

The direct sequence modulation and frequency hopping are two methods, which use the above system. The conventional models used to generate this type of communication signals is as shown in Fig 4.1.

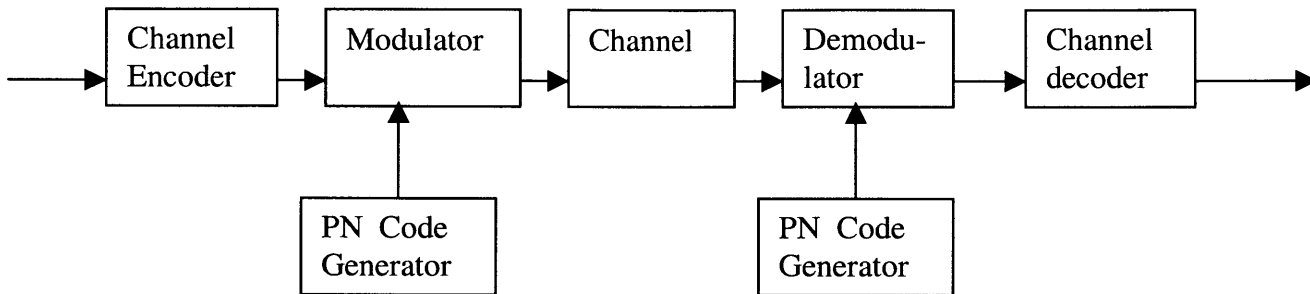

Fig 4.1 Communication System Engineering

- a) Channel encoder: Digitalizing of the input data with the carrier frequency.
- b) Modulator: Modulation of the encoded signals with the generated PN code takes place here.
- c) PN code Generator: Generation of random pattern binary PN (pseudo random) code at the transmitter end
- d) Channel: Wireless interface (external environment between the transmitter and the receiver)
- e) Demodulator: - Demodulation of the received signals with the similar generated PN code takes place here.
- f) PN code Generator: Generation of random pattern binary PN code at the receiver end.
- g) Channel Decoder: Decoding of the demodulated signal against carrier frequency to receive the input data

There are two spread spectrum techniques: Direct sequence spread spectrum (DSSS) and Frequency-hopping spread spectrum (FHSS)

### **DSSS (Direct sequence spread spectrum systems):**

The DSSS system has a relatively low SNR (signal to noise ratio) as this spreads the power over a large bandwidth (fig 4.2). Also the energy spreading makes the DSSS system produce lower interference. The DSSS method of digital communication is well explained in Fig 4.3, it shows the product signal from the random generated PN code and the input data.

Let us assume information rate is R bits per second i.e. the time period is  $T_b = 1/R$  seconds. And the bandwidth of the available channel is  $W = B_c$  Hz, the modulator spreads or expands the information signal to  $B_c$  Hz. This is done by shifting the phase of the carrier signal at W times per second according to the pattern produced by PN generator. The PN signal and the data signal gets multiplied at the modulator giving out the product signal  $V(t) * C(t)$  as shown in the figure (4.3).

Information signal

$$V(t) = \sum a_n gT(t - nT_b) \quad [n = -\infty \text{ to } +\infty]$$

$$a_n = \pm 1, \quad -\infty < n < +\infty \text{ of duration } T_b$$

Signal from PN generator

$$c(t) = \sum c_n P(t - nT_c) \quad [n = -\infty \text{ to } +\infty]$$

$$c_n = \text{PN sequence represented by } \pm 1$$

$$P(t) = \text{rectangular pulse of } T_c$$

The modulation spreads the information-bearing signal to a wider bandwidth as that occupied by the PN code signal  $c(t)$ , this spectrum spreading is shown in figure 4.4. The spectra of the information bearing signal, PN code and the convoluted spectra is seen clearly

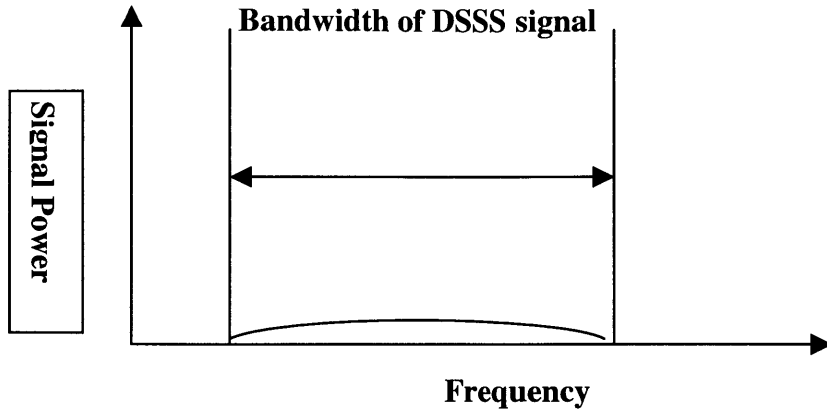

Fig 4.2 DSSS (Direct sequence spread spectrum)

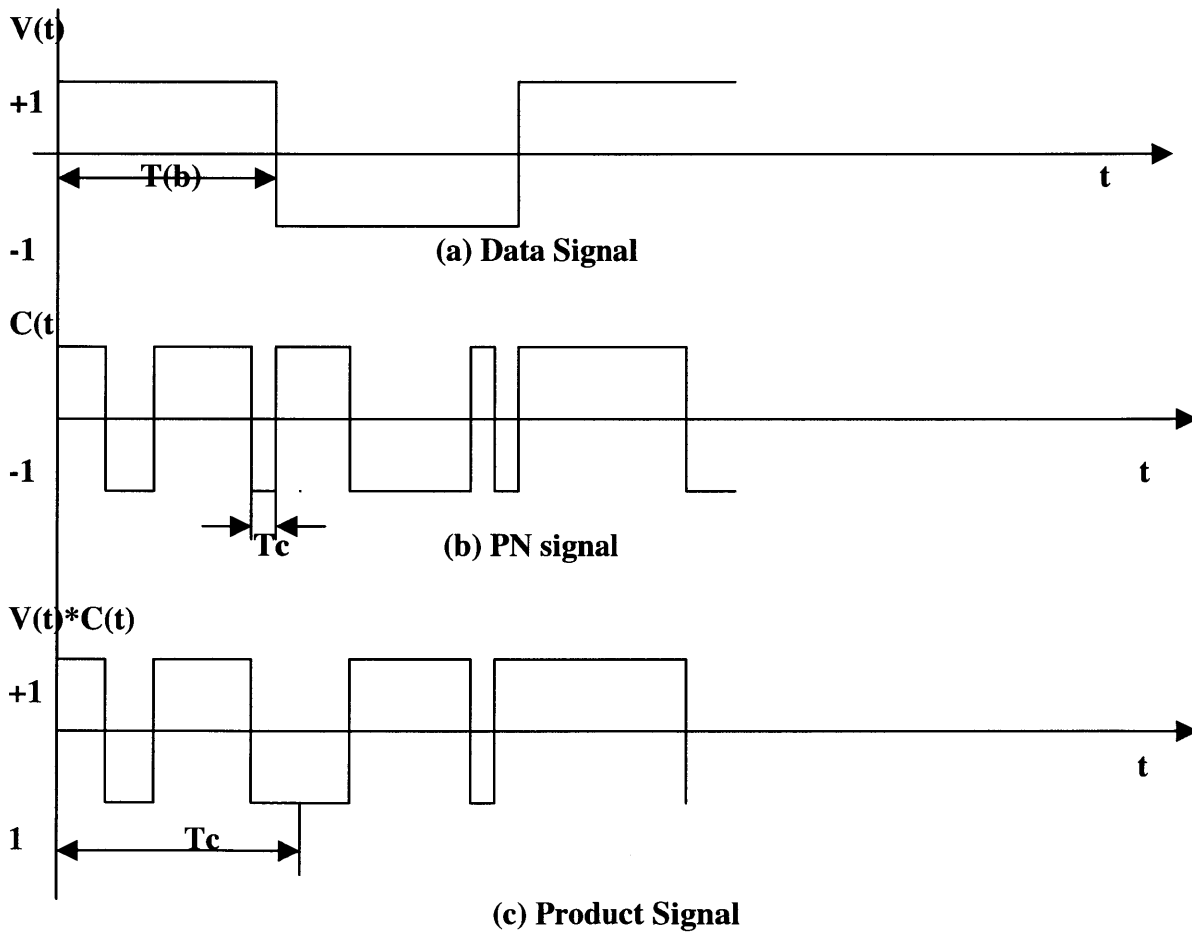

Fig 4.3 Signal analysis at transmitter

$V(t)$  - Data Signal ;  $C(t)$  - PN code ;  $V(t)*C(t)$  – Product Signal

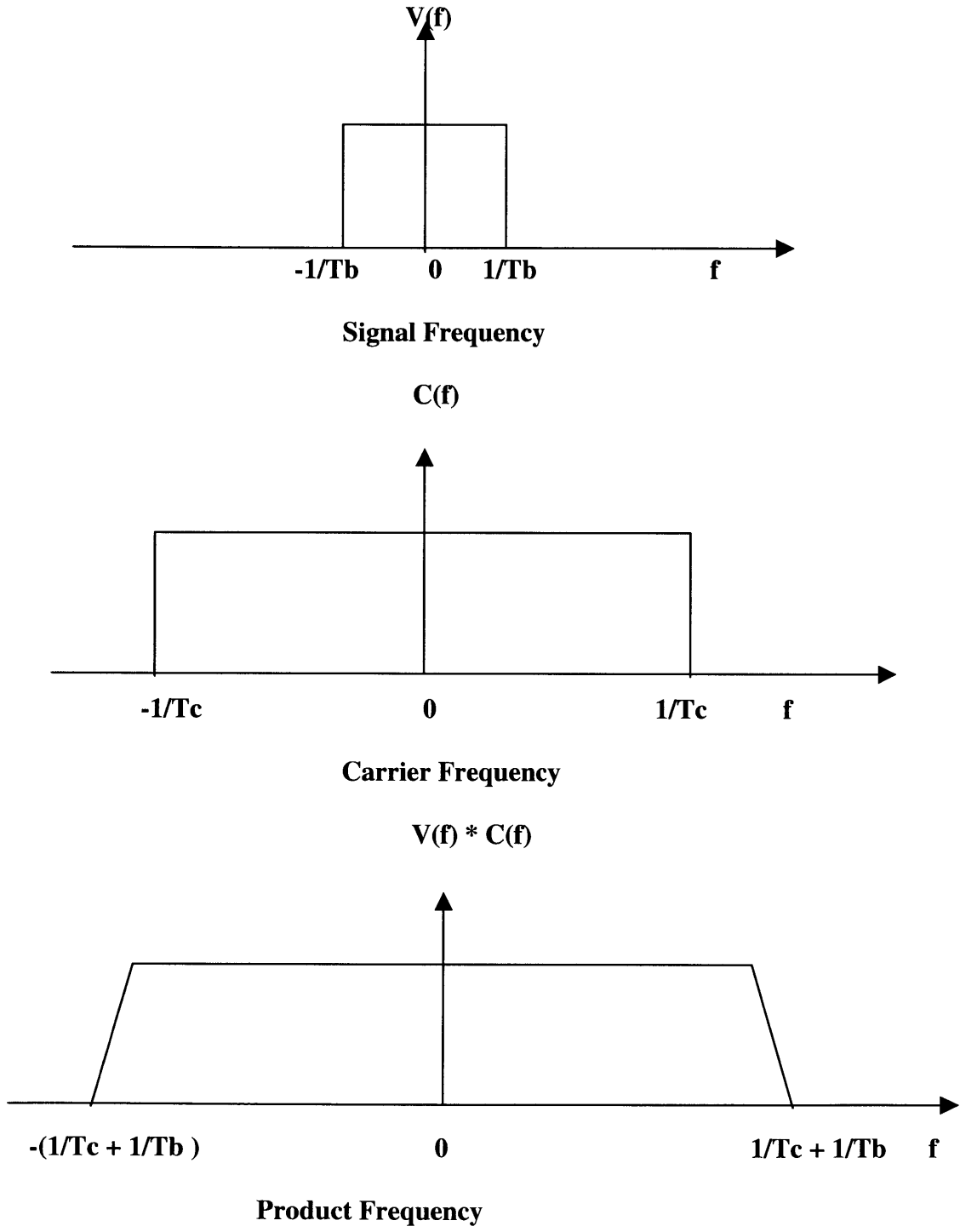

Fig 4.4 Bandwidth of Respective signals



A DSSS system is a multi user environment using the same bandwidth. The signal appears as a noise to all the users apart from the intended user. The data is encoded with a random generated PN code at the transmitter. The same PN code is produced at the receiver too and the data is decoded. It is also to be noted that the PN code is unique for every system following the DSSS. In short no PN code can be similar. The total bit pattern is called pseudo noise code and each bit in the code is known as chip, and the same bit pattern is repeated. Using an  $n$  bit chip rate the information can be spread out ' $n$ ' times in the bandwidth. Generally an  $n$  bit chip rate spreads the bandwidth by  $2^{(n-1)}$  Mhz..

The receiver uses the same generated PN code to decode the information. The noise added to the signal during transmission is also spread in bandwidth thereby almost suppressing it.

Synchronization of the receiver with the phase of the generated PN code is to be given utmost importance. The data is sent through packets and there is a preamble preceding the data for synchronization purposes.

Even if there is a mess up of one or two bits in the received data .The auto correlation between the received signal and the PN code will give the correct data. Processing gain defined as the number of chips per bit is an important parameter in DSSS systems. A high processing gain indicates that the interference is spread by that processing gain factor and the accuracy of signal at the receiver is high; where as a low processing gain indicates the increase of bandwidth. In IEEE 802.11 a chip rate of 11 bit PN code with a processing gain of 10.4 db is used.

**FHSS (Frequency Hopping Spread Spectrum):**

Frequency hopping is a new concept of sending in data wirelessly. It involves the sending of data in hops in different frequencies of a specified bandwidth. The pattern of usage of frequency in the bandwidth is predetermined and known to both the transmitter and receiver. Since the data is transmitted in narrow bandwidth the signal to noise ratio is appreciable (high). Narrow band filters can be used to filter out the required signal as data is transmitted in a smaller bandwidth. It is to be also noted that the transmitter and receiver should be hopping at the same frequency at the same time to catch the data hence synchronization between them is important. A typical FHSS system is as given in Fig 4.5.

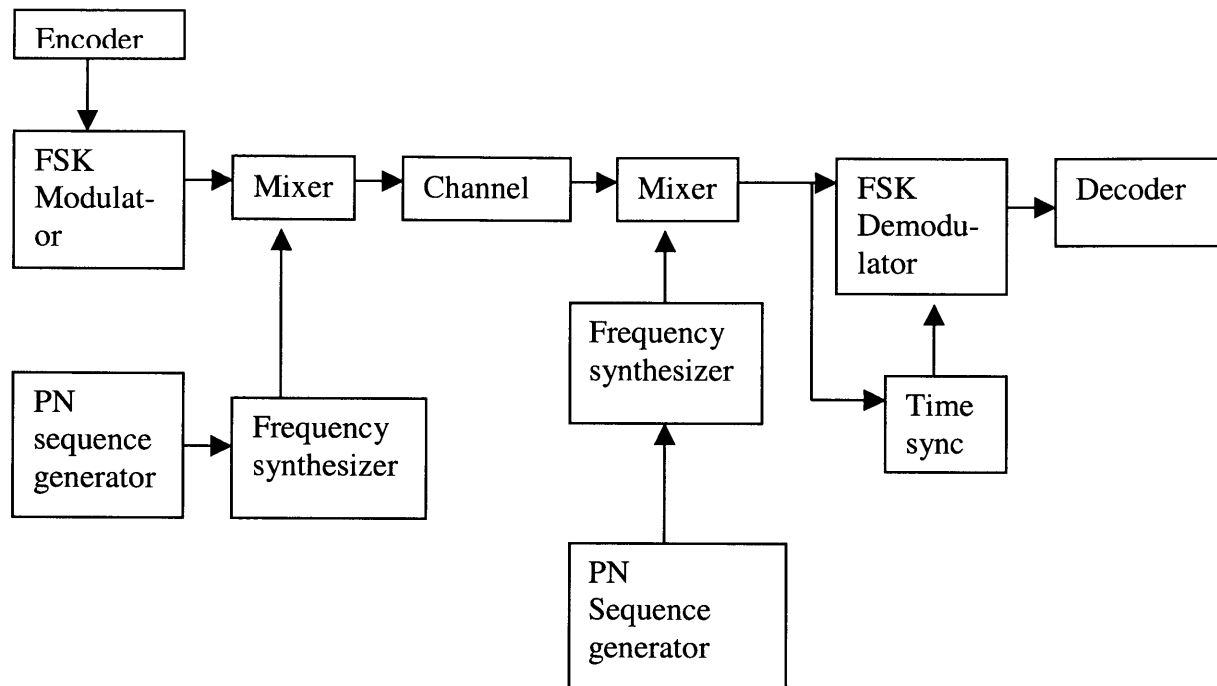

Fig 4.5 FHSS System

- a) Encoder: Digitalizing of the input data and encoding it accordingly
- b) FSK modulator: -MFSK (M-ary FSK) modulation is employed here .One of two frequencies of  $f_0$  and  $f_1$  is selected corresponding to the transmission of 0 or 1.
- c) PN sequence generator: Generation of random pattern binary PN code at the transmitter end
- d) Frequency synthesizer: Frequency based on the output of the PN sequence generator is produced. A PN sequence of  $m$  bits can generate  $(2^m - 1)$  frequencies.
- e) Mixer: Mixing of output of FSK modulator and synthesized frequency takes place and this is transmitted over the channel

- f) Channel: Wireless interface (external environment between the transmitter and the receiver)
- g) PN sequence generator: Generation of random pattern binary PN code at the receiver end
- h) Frequency synthesizer: Frequency based on the output of the PN sequence generator is produced. A PN sequence of  $m$  bits can generate  $(2^m - 1)$  frequencies. A PN code resembling the one at the transmitter end is generated here.
- i) Mixer: The received signal is mixed with the synthesized frequency thereby removing the pseudorandom frequency translation introduced at the transmitter.
- j) FSK demodulator: The resultant signal is demodulated here and the output signal is given the decoder
- k) Decoder: Decodes the exact output from the demodulated signal.

There are 2 important parameters to be taken care of in this system, which is as below:

Processing gain: This is the ratio of the total bandwidth occupied by the system to the signal bandwidth.

Dwell Time: This is the time during which a specific channel is used.

These parameters are defined by the regulatory agencies for different frequency bandwidths.

Also in this type of data transmission all the channels in that specific hopping pattern are used before they are again reused. Fast frequency hopping is the system when the hopping rate is higher than the data rate whereas slow frequency is the system when the situation is vice versa.

In the slower version of frequency hopping since the data rate is higher than the hopping rate the chances of packets being lost is high due to interference.

The frequency hopping patterns are designed such that the channel selected are orthogonal (fig3) to each other, and also it is to be noted that the channels of other patterns would not collide i.e. at the same time and at same frequency band only one packet would be sent. The advantage of using FHSS is that even if there is interference at a particular band width, there are very less chances of interference taking place in the next hop. In fast frequency hopping as the channels gets changed in a faster rate the probability of corruption of data is low and even if there is corruption it would be corrected at the receiver using suitable algorithms whereas in slow frequency hopping retransmission of data packets should take place as there would be collision of two or more data packets. The analogy to frequency hopping patterns is FHSS is pseudo random codes generated in DSSS.

#### **4.4 Wireless LAN standards:**

##### **802.11 Network**

We will discuss the various standards available for wireless transmission of the data in this section.

## Architecture of Wireless LAN's:

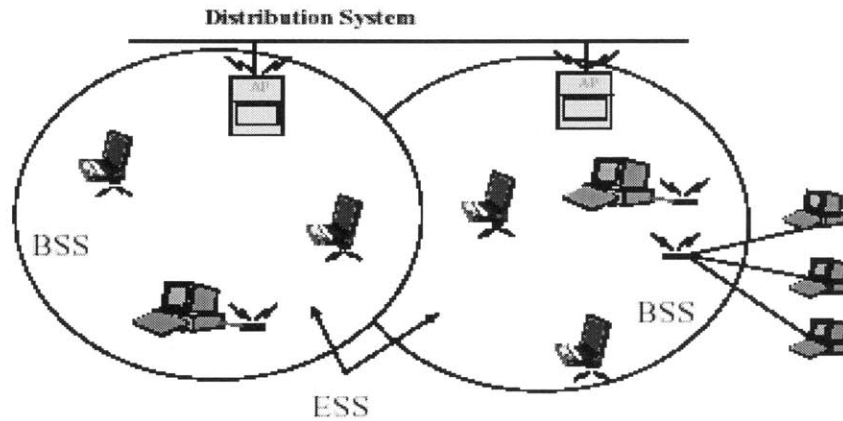

Fig 4.6 Architecture of wireless LAN

The above figure represents the architecture of the wireless LAN'S. It should be noted that the architecture is similar to the cellular telephone system. The IEEE 802.11 architecture is an integration of the architecture of mobile telephony and the wired networks. The architecture has the following components:

**B.S.S. (Basic Service Set):** This is similar to the cell concept of mobile telephony. An area is subdivided in to smaller cells referred to as BSS. A single BSS is linked to its associated AP through the wireless medium. The systems in this BSS are directly linked to this AP, which in turn would be linked to their destination via the DSS.

**A.P. (Access Points):** These are similar to that of the base stations in the mobile telephony. There is a single AP present in each cell and it looks after the traffic in its periphery. It is responsible for the communications between the transmitter and the destinations. It has an omni directional

antenna as of now. As the traffic increases, sectorization or cell splitting could be done to accommodate the new users.

D.S.S. (Distribution Service Sets): This is similar to that of the MSC(mobile switching centers) of the mobile telephony. It coordinates between all the AP's and makes decisions during hand off's and also the billing and other information is done here.

E.S.S (Extended Service Sets): This ESS is coordinating the entire IEEE 802.11. i.e. it coordinates between all the AP's , BSS's and DSS's.

Portals: It acts as an interface between the wired LAN's and the wireless LAN's .It generally present along with the AP's

**Layer Description:**

802.2			Data Link Layer
802.11 MAC			
FH	DS	IR	PHY Layer

Fig 4.7 IEEE 802.11 layers description

The two layers of the wireless LAN's consists of Data link layer and PHY layer (physical link layer)

The physical layer is the layer where the data traverses from the transmitter to the AP. It is basically the wireless medium. The processes involved in sending of the data can be:

- a) FHSS - Frequency Hopping Spread Spectrum
- b) DSSS - Direct Sequence Spread Spectrum
- c) IR – Infra Red

The speed involved in the data transfer in the above 3 processes is approximately 1-2Mbit/s

The MAC layer performs similar functions as that in the wired LAN's except for a few extra functions as fragmentations packet retransmissions and acknowledgements.

The MAC layer is accessed by the PHY layer for following functions:

- a) Distributed Coordinated Function
- b) Point Coordinate Function

The Distributed Coordinated Function is basically a CSMA/CA (carrier sense multiple access/collision avoidance) protocol. The above protocol works as follows

- a) A station senses the medium to send the data
- b) If the medium is busy the station defers its transmission to a later time
- c) But if the medium is free the transmitter starts the transmission

The above protocol works well if the traffic is low where as when the traffic is more collision can occur



Example- station A wants to send data to station B and the medium is not free hence station A waits for some time but if now another station C also wants to send the data to station B then there would be collision if the data transmission would start at the same time, hence for a high traffic environment this protocol fails.

#### Collision Avoidance:

The medium is filled with data and the receiver should know about the data to be accepted. If the packet is lost, there should be an algorithm for the packet to be retransmitted. Collision avoidance plays an important feature in wireless LAN's.

There are the following problems a designer has to take care of before designing the algorithm:

The wired LAN's follow the full duplex method and collision detection would be much easier where as if a full duplex method is to be followed in IEEE 802.11 there would be a significant increase in the cost. On a wired network all the stations are able to hear each other and they back off if the packet is not addressed to them where as in a wireless system it is not so. A transmitter senses the environment and if free starts transmitting the data but there could be a possibility that the environment near the receiver could be full of traffic and the packet gets lost.

The collision avoidance and the positive ACK (acknowledgement) scheme is the solution for this problem. The transmitter senses the medium first and if free starts the transmission where as if not defers the transmission. The transmitter is allowed to transmit, only if the medium is free for

a certain amount of time (DIFS – distributed inter frame space). A CRC frame is sent through the packet and if the CRC matches the amount of data in the packet an ACK is sent by the receiver otherwise it restrains itself from sending the ACK. Receiving the ACK will confirm that the packet has reached the receiver without collision. If no ACK is received the transmitter sends the packet again till it gets an ACK. The algorithm decides the number of retransmissions and if it still doesn't receive the ACK the packet is dropped. And this algorithm is followed for every packet sent by the receiver except for a broadcast.

#### Virtual Carrier Sense:

There is a possibility of two stations colliding because they cannot communicate with each other i.e. if a station A and station B try to communicate with each other and collision occurs.

Therefore an algorithm is required which would prevent the above.

There is a concept called virtual carrier sense indicator (NAV network allocation vector) here which would be set, and this would just receive an CTS (clear to send) or send an RTS (request to send) packet. Before transmitting the first packet the transmitter would send the RTS which would include the source address, destination address and the duration for the transaction (sending of the data and the receiving of the ACK's). The receiver on receiving this and if free and willing to take on the sent data would send a CTS. The CTS too would contain the same information as RTS. This makes the transmitter to get locked with the receiver and no other stations would interfere with these stations.

The RTS and CTS frames are short and hence, would be advantageous as they could be recognized from the data packets (significantly large ones) easily. And if the data packet were smaller than the RTS or CTS frames, they would be sent directly without the RTS/CTS transactions and would be controlled by a parameter called the RTS threshold at the stations.

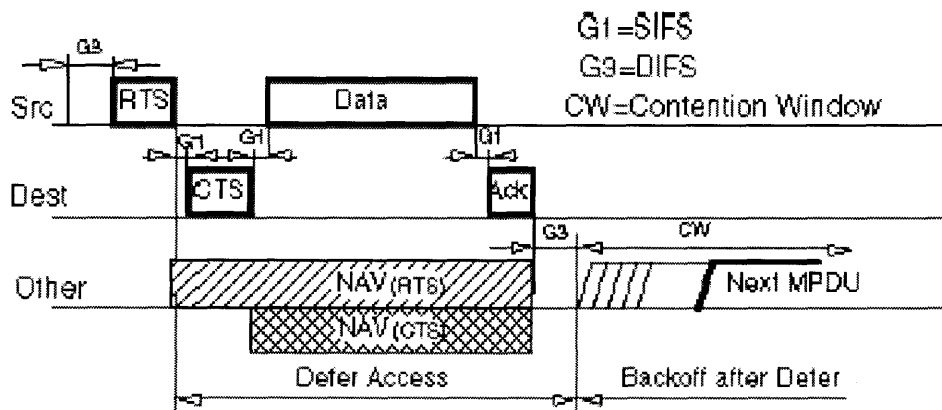

Fig 4.8 The above figure illustrates the RTS/CTS transactions between two stations and the NAV setting of their neighbors.

One more important point to be noticed here that short data frames are preferred as:

Transmission of a bigger packet would be disadvantageous as there is a high probability of it getting corrupted in the wireless medium.

Retransmission of a smaller packet would cause fewer overheads on the transmitter.

The smaller packet fits the dwell time easily. The dwell time is the time taken for the transmitting station to shift from one station to other.

### Compatibility with wired LANS:

The design of the wireless protocols should make sure that they are compatible with the wired LAN's. The wired LANS are in a position to transfer a maximum of 1518 bytes and the wireless LANS should be able to accept them. Basically a simple fragmentation and reassembly technique is done at the MAC layer to make the packet compatible. A new simple send and wait algorithm is used where in the transmitting station is not allowed to transmit a new packet before and until it:

- a) Receives an ACK for the sent fragment
- b) Decides to drop the whole frame as it has been retransmitted a lot of times.

The station is capable of sending the packet to different stations between retransmission if there is an outstanding packet of an other station left in its buffer.

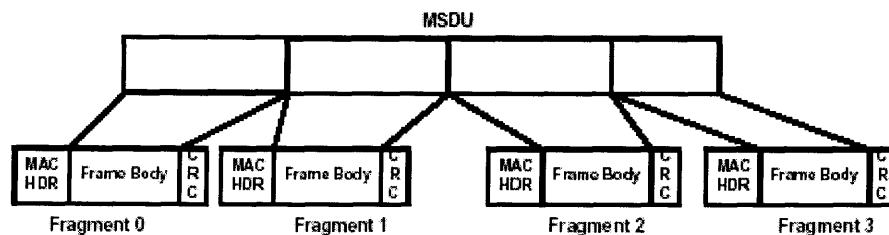

Fig 4.9 The figure shows a single large packet broken it to smaller ones

## Inter Frame Gaps:

The IEEE 802.11 defines the following interframe gaps

SIFS (short interframe gaps): after a single dialogue (fragment –ack) this SIFS comes to picture and there. This is the time when the transmitter shifts from the transmission to receiving mode.

The value basically depends on the PHY used.

PIFS (Priority Inter Frame Space): Is used by the Access Points to gain access to the medium before any other station.

DIFS : (distributed IFS): (PIFS+ one slot time) Is used by the station before it starts a new transmission.

EIFS (extended IFS): Is used by the receiver, which couldn't understand the packet and wants to prevent the collision of a future packet belonging to the current dialogue.

## Exponential back off algorithm:

This algorithm is used to prevent a new station from entering in to a dialogue session between two stations. The algorithm requires choosing a random number between 0 and n and waiting for an amount of slots before checking the medium again. The slot time is chosen in such a way that the present station will be able to check for the medium.

The algorithm is used during the following cases:

a) The transmitter senses the medium and the medium is busy, before the transmission of the first packet.

- b) After every successful transmission
- c) After every retransmission.

How a station joins a BSS:

- a) A synchronized information from the AP is required. This information is achieved in the following 2 ways.

Passive Scanning: Station waits for a beacon frame from the AP. Beacon frame is periodic synchronization information sent by the AP

Active Scanning: Station tries to find AP by transmitting probe requests frame and waiting for the probe response from AP

- b) Authentication process: Interchange of information between AP and station where each side proves the knowledge of a given password.
- c) Associate Process: It is the exchange of information between AP and station about the capabilities of BSS and other stations.

Roaming:

It is the process of moving the system from one place to another without losing connection. It is similar to handover in mobile telephony except for the reason that the disconnection in the telephony system may not affect the performance significantly but in LANs there is a massive reduction in performance because the packets have to be retransmitted again by the upper layer protocol.

Specification:

Transmit Radio Power	35 mW (15 dBm)
Maximum Operating Range	90 m (semi-open environment) to 550 m (open environment)
Power Consumption	15 mA (sleep), 250 mA (receive), 300mA (transmit)
Receiver Sensitivity (Bit Error Rate = $10^{-5}$ )	-91 dBm to -94dBm
Delay Spread (Packet Error Rate < 1%)	400 to 500 ns
Bit Error Rate	Better than $10^{-8}$
Number of Nodes	60 to 200

Table 4.2 DSSS IEEE 802.11 Wireless LAN's

Transmit Radio Power	10 mW (10 dBm) to 500 mW (27 dBm)
Maximum Operating Range	120 m(semi-open environment) to 1000 m(open environment)
Power Consumption	10 mA (sleep), 280 mA (receive), 480 mA to 680 mA (transmit)
Receiver Sensitivity (Bit Error rate = $10^{-5}$ )	-79 dBm to -85 dBm
Hopping Rate	10 hops/sec
Number of Frequency Hops	Programmable to meet regulations of all countries
Dwell Time	20 to 128 ms

Number of Co-located Coverage Areas	Up to 15
-------------------------------------	----------

Table 4.3 FHSS IEEE 802.11 Wireless LANs

### **Bluetooth Technology**

Bluetooth is a standard developed by a group of electronics manufacturers that allows any sort of disparate mobile electronic equipment – from computers and cell phones to keyboards and headphones to make their own connections and allow synchronized data transfer between them in the short distance-range.

Bluetooth is intended to be a standard that works at two levels:

- It provides agreement at the physical level. Bluetooth is a radio-frequency standard.
- It also provides agreement at the next level up, where products have to agree on when bits are sent, how many will be sent at a time and how the parties in conversation can be sure that the message received is the same as the message sent.

Bluetooth devices uses frequency hopping in time slots to communicate between each other. Bluetooth has been designed to operate in noisy radio frequency environments, and uses a fast acknowledgement and a frequency-hopping scheme to make the communication link robust, communication-wise. Bluetooth radio modules avoid interference from other signals by hopping to a new frequency by hopping to a new frequency after transmitting or receiving a packet.



'Bluetooth' is named after a Danish king Harald Bluetooth of the 10<sup>th</sup> century. The Special Interest Group which was established in the 1988 for further research in Bluetooth technologies include Intel , Microsoft , IBM, Toshiba, Ericsson, Nokia, and Puma Technology.

**Protocol and Characteristics:**

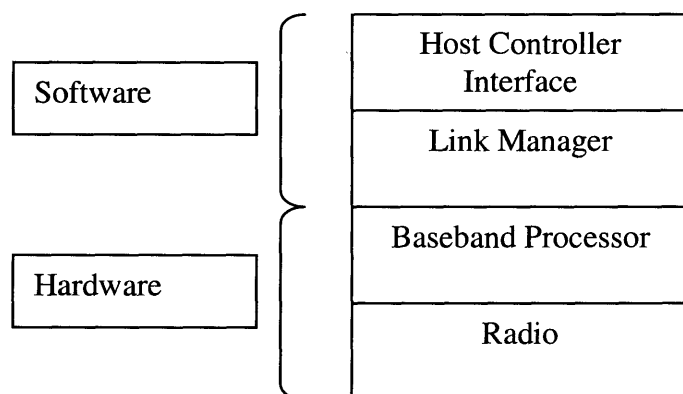

Fig 4.10 Bluetooth Layers

Layer	Function
Radio	Short Range microwave transceiver with clock and external transmitter using FHSS
Baseband Processor	Specifies procedures needed to support the exchange of real-

	<b>time voice and data as well as network information</b>
<b>Link Manager</b>	<b>Software function that executes protocols such as link establishment, network configuration and authentication</b>
<b>Host controller interface</b>	<b>Interface for Bluetooth host</b>

Table 4.4 Bluetooth Stack layers

Specifications:

Topology	Supports up to 7 simultaneous links
Flexibility	Goes through walls, bodies, cloths
Data rate	720 Kbps
Power	0.1 watts active power
Size/Weight	25mm*13mm*2mm, several grams
Cost	\$5 per end point
Range	10 meters or less Up to 100meters with PA
Universal	Intended to work anywhere in the world
Security	Very secure, link layer security

Table 4.5 Specifications of Bluetooth

Bluetooth Network Architecture:

Piconet:

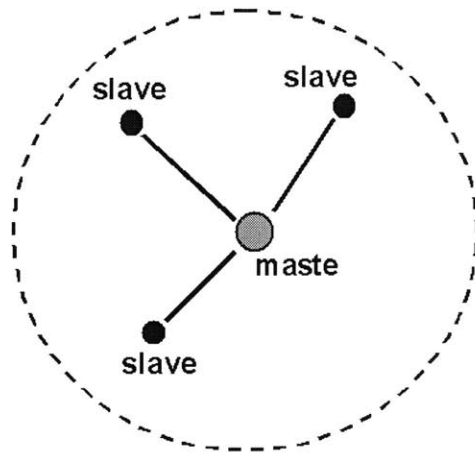
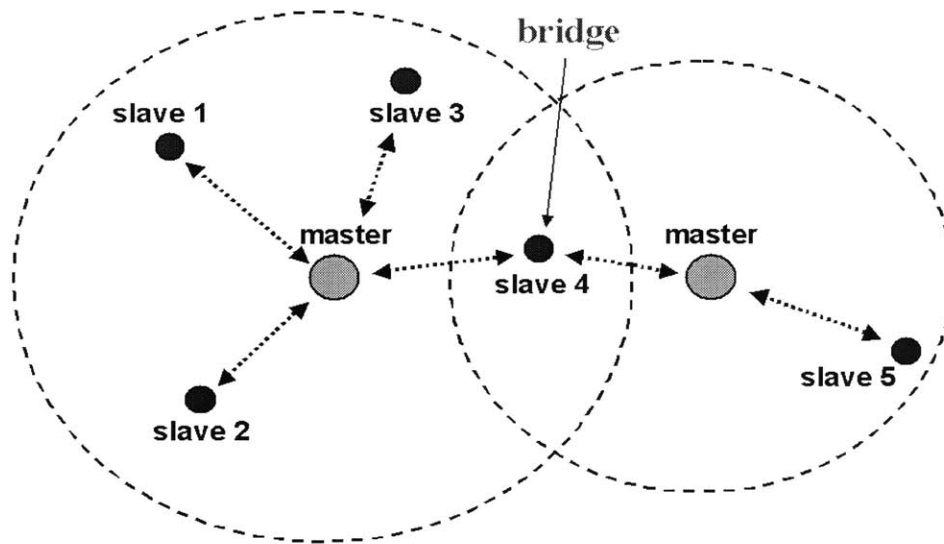

Fig 4.11 Piconet

Bluetooth piconets are the basic building blocks of larger Bluetooth networks. A piconet consists of as many as eight Bluetooth – enabled devices or nodes, with one device as the master controlling as many as seven slaves.

Scatternet



4.12 Scatternet

Multiple piconets with overlapping coverage areas form a scatternet. Each piconet can only have a single master. However, slaves can participate in different piconets on a time-division multiplex basis. In addition, a master in one piconet can be a slave in another piconet.

#### 4.5 Bluetooth Vs 802.11b

There is always a constant debate as to which technology is better than the other. Companies have begun to realize that 802.11 and Bluetooth are designed for different roles. There is no point trying to force one technology to do what the other is better suited for. Bluetooth technology is designed for quick, seamless short range networks, and features better power consumption, small protocol stack, robust data and voice transfer and cheap price. It is ideally suited for WPAN (wireless personal area network). 802.11b is designed for infrequent

mobility, IP-based data transmission, medium range and high data rate. These features make it ideal for WLAN (wireless local area network).

After the comparison between the two technologies, we will try to look in to the possibilities of the two technologies to co-exist. The basic principle behind enabling Co-existence is to ensure that a Bluetooth and 802.11 devices located near each other never use the same frequency at the same time. There are various methods and theories proposed for the interference reduction. For 802.11b, one such proposal is to fragment 802.11 packets to ensure that any interference is minimized. For Bluetooth, Texas Instruments has come up with a proposal of 'Intelligent Frequency Hopping', which is a non-spec method of never hopping to certain frequencies.

#### Technology Selected for the Smartwells Project:

After the review conducted on the various contemporary wireless standards in this chapter, we decided to use 802.11b protocol for the following reasons.

1. **Longer Range:** Since our project consists of transfer of data from the ground to the third floor of the building (as in the case of the Parson's Lab) and from the beach to the research office (as in the case of Waquoit Bay reserve) which is more than 200 meters, the 802.11 standard would be ideal for this distance range.
2. **Data Transfer:** Data transfer rate of 802.11 is better than the Bluetooth technology.
3. **Compatibility:** The standard is wide spread and is used in most of the places for the wireless LAN architecture. The usage of 802.11 would make it simpler for any further enhancements with regard to implementation or hardware.

## **5 Deployment at Waquoit Bay**

### **5.1 Overview:**

The present research project carried out at the Waquoit Bay is the Water Quality Monitoring Program. It involves water quality measurements at 7 sites within Waquoit Bay estuary for the purposes of constructing a long time series of water quality information to determine trends as well as provide a sentinel role to detect changes and events.

The Smartwells project would be an ideal implementation for the above mentioned project. There would be real time monitoring and data archiving of the water quality from the various sensors installed.

### **5.2 Site Conditions:**

The site consists of a maximum 20 foot wide beach with fairly stable water conditions. There is a small hill of height 20 meters adjoining the beach. The office of the Waquoit Bay Reserve is present on the hill. The maximum distance from the beach to the office would be around 200-250 meters.

Available resources:

The Waquoit Bay Reserve office has a personal LAN of around 8-10 computers. It runs a proxy server to connect to the internet via dial-up connection. There is a proposed plan to move over to

a DSL/T1 connection in a matter of few months. Once the connection is available it would be possible to implement our Project.

### **5.3 Proposed Plan of Implementation**

The Sensors with the FieldPoint module will be mounted on the beach. The FieldPoint module can be stationed in the boathouse which is around 10 meters from the beach and has a power supply. The sensors will be put in a screener (Johnson's screen) and placed around 5 feet in to the sand. This depth would be ideal for the measurement of the dynamic changes of the water quality. The FieldPoint module is connected to the Ethernet and Serial converter which wirelessly transmits the data over to the data server. The Ethernet and Serial converter can be placed at a slightly higher level from the ground as there is no straight line of site from the beach to the Research office (which stations the server).

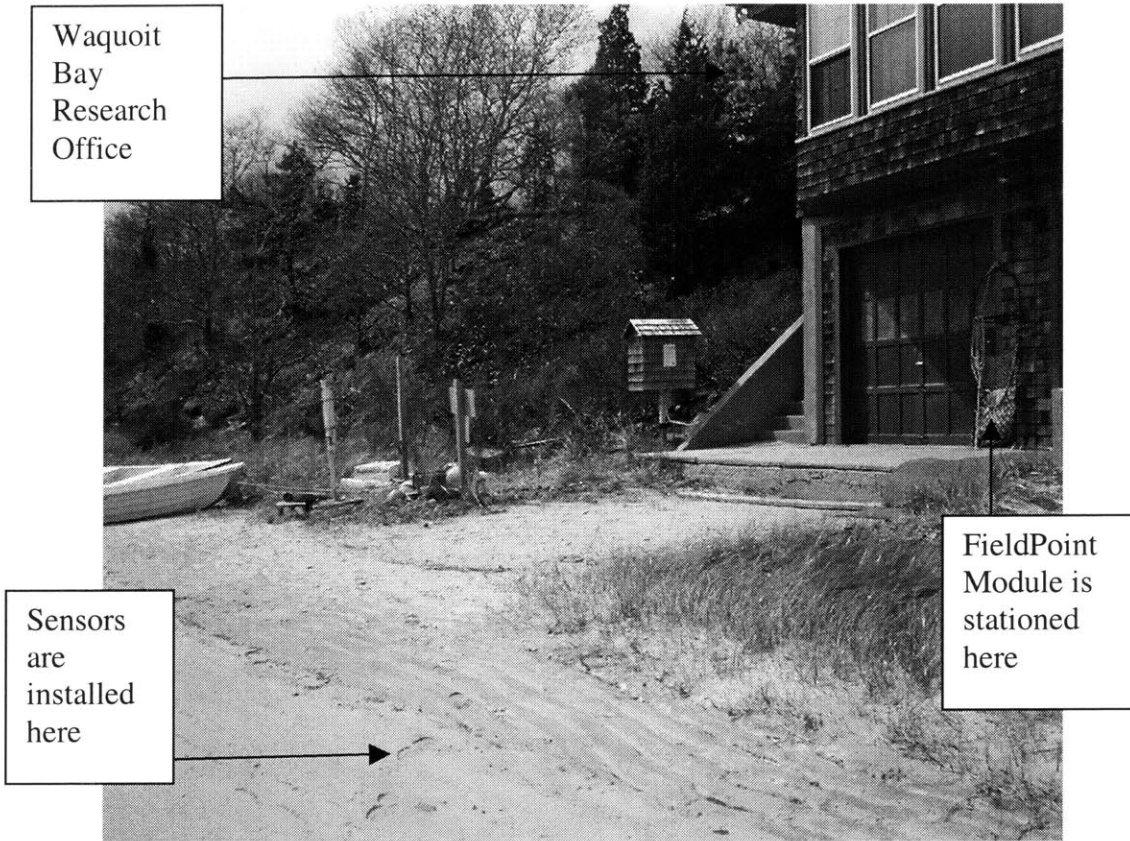

Fig 5.1 Waquoit beach – sensors will be placed here

The server and the residential gateway would be placed in the research office of the Waquoit Bay reserve.



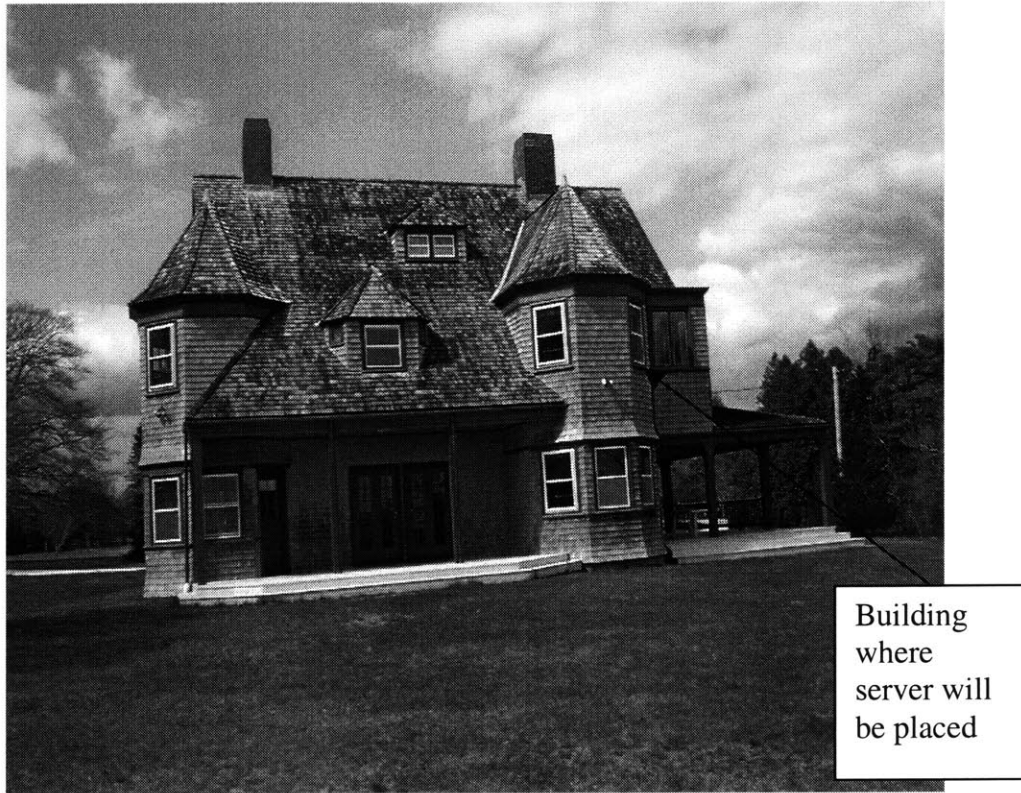

Fig 5.2 Waquoit Bay Reserve research office

The present implementation of our project would involve collecting the data and archiving it without Ethernet access. This would mean that the archived data resides on the server and can be accessed online only when the proxy server is connected via the available dial-up connection.

## 6 Conclusions

Smartwells project has given the initiative for further research in the possible Integration of IT and Environmental engineering studies. The importance on Real-time monitoring and analysis given by MIT on various Environmental issues would help in resolving the problems of pollution.

The project gave the group an opportunity to understand the latest technology and available industry standards. The various principles involved in the sensors were investigated and the best available sensor with contemporary technology was selected. The best available industry standard for Wireless LAN with respect to our usage requirement was chosen. New forefront technology such as the Bluetooth solution was discussed upon during the progress of the project.

The first phase of the project i.e. the prototype for Smartwells project involving integration of various sensors and wireless transmission of the data is complete. The data transmitted wirelessly is stored in a database and archived. The next phase of the project would involve real time deployment of the project at the selected site (Waquoit Bay). The present selected sensors would be installed in the beach using a Johnson Screener and numerous data would be collected for various research purposes.

With environmental issues being of prime concern in today's world, academic institutions like MIT with rich research experience would be one of the solution providers for such critical issues. The industry such as in the Smartwells Project (icampus project sponsored by Microsoft) should

interact with the academic institutions for better usage and implementation of the available technology. The installation of such technology would become cheaper if more people are educated on the various technological issues and there is widespread use of it.

## References

[1] Bluetooth - Working and Technology

Official Bluetooth website <<http://www.bluetooth.com>>

[2] Bluetooth – Network architecture

<<http://palowireless.com>>

[3] Data Acquisition module - Field Point Module

National Instruments <[www.ni.com](http://www.ni.com)>

[4] Direct sequence spread spectrum and Frequency-hopping spread spectrum

Communication System Engineering

-by Masoud Salehi and John G Proakis

[5] IEEE 802.11 - Architecture

<<http://www.sss-mag.com> >

[6] IEEE 802.11 – Specifications

High-Speed Wireless ATM and LANS

by Benny Bing

[7] IEEE 802.11 - Working

<<http://www.sss-mag.com>>

[8] IEEE 1451.2 Standard

“A smart transducers interface for sensors and actuators – transducer to microprocessor communications protocols and transducer electronic data sheets (TEDS) formats,” Piscataway,

NJ : IEEE Standards Department, 1998

[9] Real Time data monitoring - Flagpole Project

<<http://flagpole.mit.edu>>

[10] Sensors – Introduction and Classification

Fundamentals of Programmable Logic Controllers, Sensors and Communications

by John Stenerson

[11] Sensor Technology – Principles and basic applications

Understanding Smart Sensors

by Randy Frank

[12] Sensors: Water-level sensors, Conductivity sensors, Rain gauges

Global Water Resources (<http://www.globalw.com>)

[13] Waquoit Bay Reserve research

<<http://www.waquoitbayreserve.org>>

[14] Wireless Standards – Comparison between IEEE802.11 and Bluetooth

Phony conflict: IEEE 802.11 and Bluetooth wireless technology

by Miller B

[15] Wireless Networks - Residential Gateway

<<http://www.orinocowireless.com>>

[16] Wireless LAN – Standards and classifications

Wireless Communications

by Rappoport

