

no. 2719
Thesis
1921



THESIS

SAILING FLIGHT.

DESCRIPTION AND DISCUSSION OF A NEW METHOD
OF MOTORLESS FLYING.

CHARLES J. BOSSART

COURSE XVI

CHAPTER I

-:-:-:-:-

THEORY AND DESCRIPTION

1. Let us consider two homogeneous fluids a and b separated by an horizontal plane π and let us suppose that the fluid a moves with respect to the fluid b with a velocity V_w parallel to the plane of separation. For simplicity's sake, we shall suppose the fluid b be immobile. It follows that absolute velocities will be velocities counted with respect to b

In the fluid a we place an airfoishaped body A (Fig.1); in the fluid b a similar body H . Both airfoils having their leading edges perpendicular to the separation plane π and occupying one with respect to the other a position such that their upper surfaces face opposite directions of space.

The two airfoils are tied rigidly together with some sort of an undeformable connection C .

We shall assume that, except for the reactions of the two fluids on the airfoils A and H , there are no exterior forces acting on the rigid system AH . This system will be free to move in any direction along the plane π . We suppose however that its motion is only

two-dimensional, i.e.: airfoil A does not leave the fluid a, airfoil H does not leave the fluid h and their leading edges remain perpendicular to the plane π . It will be shown later how this can be realized in practice

Finally we assume that the system AH is stable with respect to both fluids a and h, i.e. when the system is moving with a certain angle of attack i_a in the fluid a and an angle of attack i_h in the fluid h, any change in those angles will create a moment that will tend to bring them back to their original values. This last requirement is of course easily fulfilled by means of stabilizers.

If we now give to the system AH a velocity V of a direction and magnitude such, that the reactions R_a and R_h created by the fluids on the two wings are equal and of opposite signs:

$$\bar{R}_a = -\bar{R}_h$$

it is obvious that, the resultant force being zero, the the body AH will conserve indefinitely its velocity V.*)

2. Let us study the relations existing between the different reactions and velocities of this motion. Briefly recapitulating our data:

The fluid a moves with respect to the fluid h

*) This might seem against the law of conservation of energy. It is evident, however, that the kinetic energy of the fluid a supplies the energy of the motion.

with a velocity V_w

The fluid a moves with respect to the system AH with a velocity V_a . It causes a reaction R_a .

The system AH moves with respect to the fluid b with a velocity V . It sustains from the fluid b a reaction R_b .

As we have seen already the two fluid reactions are tied by the relation:

$$\bar{R}_a + \bar{R}_b = 0 \quad (1)$$

We know that these reactions can be expressed in terms of the speeds. Using the usual symbols:

$$R_a = \frac{1}{2} c_a \rho_a S_a V_a^2$$

$$R_b = \frac{1}{2} c_b \rho_b S_b V^2$$

(1) can be written now:

$$c_a \rho_a S_a V_a^2 = c_b \rho_b S_b V^2$$

whence:

$$\frac{V_a}{V} = \sqrt{\frac{c_b \rho_b S_b}{c_a \rho_a S_a}} \quad (2)$$

Adding vectorially the different relative speeds we find another relation:

$$\begin{array}{l} \text{Rel. vel. of } a \text{ with resp. to } b = \bar{V}_w \\ \text{" " " } h \text{ " " " } \text{AH} = -\bar{V} \\ \text{" " " } \text{AH} \text{ " " " } a = -\bar{V}_a \\ + \hline \text{" " " } a \text{ " " " } a = \bar{V}_w - \bar{V} - \bar{V}_a = 0 \end{array}$$

or:

$$\bar{V} + \bar{V}_a - \bar{V}_w = 0 \quad (3)$$

Finally these speeds are tied together by still another element, namely the fineness ratios of the airfoils A and H. Indeed, let us draw the triangle visualizing the vectorial addition ⁽³⁾ (Fig. 2). This triangle will play an important part in our discussion. Henceforward ~~we~~ shall refer to it as the triangle of speeds.

Let us call now φ_a the angle of the force R_a with the perpendicular to the speed V_a and φ_h the angle of the force R_h with the perpendicular to the speed V .

We know that these angles depend directly from the fineness ratios of A and H :

$$\cot \varphi_a = (L/D)_A$$

$$\cot \varphi_h = (L/D)_H$$

If we draw through the summit O of the triangle of speeds a perpendicular p to the direction $R_a R_h$. It will make an angle φ_a with V_a and an angle φ_h with V . The angle at the summit of the triangle is the sum of those two angles. It follows that the speeds V and V_a make an angle φ such that :

$$\varphi = \varphi_a + \varphi_h \quad (4)$$

3. Being given the velocity V_a the triangle of speeds will be completely determined by the two data V/V_a and φ furnished by the formulae ⁽²⁾ and ⁽⁴⁾.

Let us see how the velocity V , i.e. the

absolute velocity of the system AH, varies with those two quantities V/V_a and φ , and in particular, let us find out which values we should give them in order to make V as large as possible.

Considering in the first place the influence of the ratio V/V_a , we see that, being given a certain value of φ , the summit O of the triangle of speeds has to lie on the circumference MON (Fig.3) capable of the angle φ . When V/V_a varies O moves along this circumference. (We assume here that V/V_a is changed by some means that does not affect φ , which as we shall see later can actually be done in practice.) V will reach its maximum value when occupying the position O₁M which is a diameter of the circumference. We can write then:

$$V_{\max} = \frac{V_a}{\sin \varphi} \quad (5)$$

and this will be obtained when :

$$V/V_a = \sec \varphi \quad (6)$$

The formula (5) immediately shows the influence of φ . In order to make V_{\max} as large as possible we have to make φ as small as possible

4. To what amount these two requirements?
Formula (4) shows that reducing φ means reducing φ_a and φ_h i. e. having both airfoils A and H working at high L/D .
Assuming this first condition satisfied, φ is small and (6) can be written in first approximation :

$$V = V_a$$

What by virtue of (2) means:

$$c_a \rho_a S_a = c_h \rho_h S_h$$

But both c_a and c_h correspond to the angle of incidence of greatest L/D . Hence we may assume:

$$c_a = c_h$$

and we get the condition:

$$\rho_a S_a = \rho_h S_h$$

or:

$$\frac{S_a}{S_h} = \frac{\rho_h}{\rho_a} \quad (7)$$

Summarizing : In order that the system AH should have with respect to the fluid h a velocity V as great as possible

1°. Both the cellules A and H should be given the greatest possible fineness ratio.

2°. Their wing areas should be in inverse proportion to the densities of their respective fluids.

5. A mechanism such as we have schematically described in the above paragraphs, actually exists in the form of the sailing boat. The two fluids in relative motion a and h are here the air and the water. V_w will be the wind speed, V the speed of the ship. the sail and the keel are acting as airfoil shaped bodies i.e. bodies whose fluid resistance has a component perpendicular to the relative velocity of the fluid.

When the ship is moving at constant speed we have $R_a = R_h$ and the velocities V , V_a and V_w satisfy the equations (2), (3) and (4). Consequently all our reasoning applies to the sailing boat and if we desire to build a fast ship we shall have to observe the two requirements of paragraph 4.

We find indeed that the first of those requirements is the chief concern in yacht building. Here progress has always consisted in increasing the fineness of the keel. The rather recently acquired aerodynamical knowledge has been successfully applied to better the L/D of the sails. So for instance were remarkable results obtained by replacing the sails by regular airplane wings.

It is however impossible to comply with the second requirement, to wit the rational proportioning of keel and sail areas. There are two reasons for this we both overlooked in our theoretical development:

- 1°. The forces R_a and R_h are creating a capsizing moment which has to be balanced. (Fig.4).
- 2°. The forces of gravity have to be taken into account.

In the case of the sailing boat this moment and this force are balanced by the hydrostatical reactions of the hull. The buoyancy of the ship carries its weight and prevents it from capsizing. The disponible buoyancy however limits rapidly the sail area. It is

easy to see that if we fulfilled the relation (7) the buoyancy would be absolutely insufficient not only to hold the ship upright but even to carry the weight of the sails not to speak of any useful load. Indeed, the density of water being about 800 times that of air, the sail area should amount to 800 times the keel area. Which is absolutely out of proportion. The result is that in a sailing boat we can never attain a favorable V/V_a ratio. The triangle of speeds will always be flattened out as shown in Fig. 5. The highest speeds attainable will never be much in excess of the existing wind speed. We cannot take advantage of the enormous amount of energy in presence that would permit much higher speeds if efficiently utilized.

6. The merit of the new method of flying we are describing is to do away with these difficulties

The principle of this method consist in making the two cellules A and H two independent and individually stabilized units. These two units will no longer be rigidly connected but the aerodynamic and hydrodynamic reactions will be transmitted from one to the other by means of a flexible cable. The aerial unit will be a glider and the aquatic part a small float in the form of an airplane wing provided with some sort of a stabilizing devise. (Fig. 6)

The sole function of the float will be to create an hydrodynamic reaction. It does not need to

have any buoyancy as

1°. the load carrying function will be transferred to
the glider

2°. the capsizing moment will be done away with all
together as the cable that ties the float to the plane is
unable to transmit any moment. In other words, the
hydrodynamic reaction will always be in line with the pull
of the cable. (Fig. 6)

Once we don't need to worry any more about
the buoyancy of the keel, there is no reason why we should
not give it the area which was proven to be the most
efficient for obtaining high speeds, to wit:

$$S_h = \frac{1}{800} S_a$$

7. Before we go any further we have to make
sure that the theory we developed in the first paragraphs
may be applied to this new system.

First of all, in how far is this theory
affected by replacing the rigid connection between the two
cellules by a non rigid one? We introduced the assumption
that A and H were tied rigidly together only once in our
reasoning. That was when establishing the relation (3).
Indeed this, this relation is only true when the cellule
A has no velocity with respect to the cellule H. This, as
a rule, not being the case when no rigid connection exists
(3) should be replaced by a more accurate formula :

$$\begin{array}{l}
 \text{Rel. vel. of } a \text{ with resp. to } A = \bar{V}_a \\
 \text{Rel. vel. of } A \text{ " " " } H = \bar{V}_{AH} \\
 \text{" " " } H \text{ " " " } h = \bar{V} \\
 + \text{ " " " } h \text{ " " " } a = \bar{V}_w \\
 \hline
 0 = \bar{V}_a + \bar{V}_{AH} + \bar{V} - \bar{V}_w
 \end{array}$$

It can be shown however that V_{AH} always will have a small value. Let us suppose that V_{AH} is not zero. As the distance AH (Fig. 7) is constant, V_{AH} has to be perpendicular to AH. Let us suppose that at a given instant R_a and R_h are in line with the cable AH as shown in position I. After a certain time Δt the whole will have moved to the position II. As both the cellules A and H are static ally stable, their angles of attack remain the same. The angles of R_a with V_a and R_h with V remain the same and $R_{aI} \parallel R_{aII}$, $R_{hI} \parallel R_{hII}$. But $(AH)_I$ will not be parallel to $(AH)_{II}$. Consequently the forces R_{aII} and R_{hII} are no longer in line. They can be decomposed into R_{a1} and R_{h2} who balance each other, and R_{a2} and R_{h2} who will create accelerations in a direction opposite to that of V_{AH} . V_{AH} will decrease, change its sign. When AH gets parallel again to $(AH)_I$ the accelerations change sign and again check the increase of V_{AH} . A damped osvillatory motion of A with respect to H will be the result. V_{AH} will never grow large its average value will be zefo, so that in the study of the absolute motion of the system (A+H) as a whole we may still apply formula (3) and work with the triangle of speeds.

As a matter of fact unless an absolutely ideal steadiness of flow prevails, this oscillating motion of the direction AH around its position of equilibrium will be the normal conditions. Moreover the angles of incidence of both the cellules A and H will be submitted to a similar periodical variation, which will be linked to this former motion. In order to make a complete quantitative study of these different interdependent motions, it would be necessary to establish again the equations (1), (3) and (4) for conditions of disturbed static equilibrium, that is to say with the introduction of masses and accelerations. The discussion of a system of simultaneous partial derivative equations having as independent variables the angles of attack i_A and i_H the angular velocities $\frac{di_A}{dt}$, $\frac{di_H}{dt}$ and the wind speed V_w would permit to find the conditions required for dynamic stability, i.e. for the damping of the perturbatory motions. It would be possible too to find the period and the damping characteristics of these motions. As this development would be long and only of academic interest we shall not go into it here.

8

The sailing flight differs still in another respect from the theoretical case we treated in the first paragraphs. Indeed, in the theoretical case the

forces R_a and R_k had no other function but assuring the horizontal motion of the system. In the real case they have two other functions to perform, namely:

1^o. to carry the glider, the cable and the useful load.

2^o. to apply a vertical tension to the cable AH. We know indeed, that this cable will assume the shape of a catenary. If the traction applied at the lower end of this catenary was purely horizontal, the catenary would be tangent to the horizontal in this point (Fig. 8). As R_k is necessarily situated beneath the surface of the water this would mean that the cable is dragging through the water. This, of course, we cannot admit, as it would create an enormous resistance and badly impair the L/D of the float. It follows that the pull of the float on the cable should be pointed downwards.

Both those new functions of the aerodynamic and hydrodynamic forces require that they possess a vertical component. This is, of course, obtained by inclining both the glider and the keel. Their leading edges will no longer be vertical as in the theoretical case. The problem ceases to be a two-dimensional one, we have to consider the position of the different forces in the three-dimensional space.

Again, how is the general theory affected by this modification? We find (Fig 9) that the weights and the vertical components of R_a and R_h are balancing each other, and that all what has been said in the paragraphs one to four can be applied to their horizontal components.

Consequently formula (1) becomes

$$R_{aH} = R_{hH}$$

and formulae (2) and (7) are similarly modified. The most favorable ratio S_a/S_h is no longer a constant, but varies with the speed and the shape of the cable. This is of no great importance, because we shall be able to give the desired value to S_h at any moment.

The angles φ_a and φ_h will be respectively the angles of R_{aH} with a perpendicular to V_a and of R_{hH} with a perpendicular to V . Let us decompose R_a in a drag component R_{ax} , an horizontal lift component R_{ay} and a vertical lift component R_{az} (fig 9). We have:

$$\cot \varphi_a = \frac{R_{ay}}{R_{ax}}$$

similarly

$$\cot \varphi_h = \frac{R_{hy}}{R_{hx}}$$

We see that φ_a and φ_h are greater than in the theoretical case. Consequently the attainable speeds will be smaller. The efficiency of the system is adversely affected by the necessity of carrying the weight and holding up the cable.

Moreover, φ_a and φ_h are no longer a function of the angles i_a and i_h only. φ_h depends on the slope of the cable θ and φ_a both on θ and on the air speed V_a .

Let T be the traction applied at the lower end of the cable. Decomposing it in horizontal and vertical components we get:

$$T_v = T \sin \theta = R_{h_v}$$

$$T_H = T \cos \theta = R_{h_H}$$

The slope θ will largely depend on the steadiness of the sea and the air. When both air and water are calm we can adopt a small θ , which, as we shall see later, gives a high efficiency. On the contrary, when the sea is choppy, the cable is likely to be struck by the waves and θ must be large. If the air is bumpy a large θ is required again, because we have, for safety's sake, to maintain the glider at sufficient height above the surface of the water. It lies in our power to give any desired value to θ by varying the altitude of the plane.

If we call W the total weight of the plane and the cable, we can write:

$$\overline{R}_a = \overline{T} + \overline{W}$$

or

$$R_{a_v} = T_v + W$$

$$R_{a_H} = T_H$$

and:

$$R_a = \sqrt{T^2 + W^2 + 2 \sin \theta T W}$$

According to the definition of φ_a :

$$\begin{aligned} \sin \varphi_a &= \frac{R_{ax}}{R_{aH}} = \frac{R_a}{R_{aH} \left(\frac{L}{D}\right)_a} = \frac{\sqrt{T^2 + W^2 + 2 \sin \theta T W}}{T \cos \theta \left(\frac{L}{D}\right)_a} = \\ &= \sec \theta \frac{1}{\left(\frac{L}{D}\right)_a} \sqrt{1 + \left(\frac{W}{T}\right)^2 + 2 \sin \theta \left(\frac{W}{T}\right)} \end{aligned}$$

W is a constant. T varies with V_a consequently $\frac{W}{T}$ varies with V_a and so does φ_a . When V_a decreases a greater fraction of the air force R_a is needed for carrying the weights. R_a is going to point upwards (Fig. 10). The Y-axis of the plane nears the horizontal. If V_a continues to decrease, at the limit the totality of R_a will be needed for weight carrying purposes. In this case the wing will be horizontal

$$R_{ay} = 0 \quad \text{and} \quad \varphi_a = 90^\circ$$

On the other hand, when V_a increases indefinitely W/T tends toward zero, and:

$$\sin \varphi_a = \sec \theta \frac{1}{\left(\frac{L}{D}\right)_a}$$

In the majority of cases V_a will be such that this latter formula can be used as a first approximation. (A numerical example of the change of φ_a with speed has been developed in paragraph 17.)

We consider the weight of the float as negligible compared to the other forces acting on it. It follows that φ_h is independent of the speed we have:

$$\sin \varphi_h = \frac{R_{hx}}{R_{hH}} = \frac{R_h}{R_{hH} \left(\frac{L}{D}\right)_h} = \frac{T}{T \cos \theta \left(\frac{L}{D}\right)_h} = \sec \theta \frac{1}{\left(\frac{L}{D}\right)_h}$$

9. Description

The glider does not require much of a description as it differs very little from the ordinary glider. The only difference is that the sailing glider will be more sturdy. It has indeed to resist to much higher forces than is the case with the ordinary airplane. The machine will have to be built for unusually high wing loadings. The reason for this will be given later. (chapter III)

In view of this fact the biplane cellule seems to impose itself rather than the monoplane. The biplane will have the other advantage that its span is small, so reducing the danger of touching the water with the wing tips.

This danger, will necessitate too a very great lateral stability. Moreover, the glider should be absolutely spinproof and this for two reasons:

1° the glider will constantly be flying at an higher angle of attack than an ordinary plane (the angle of maximums L/D or thereabout) so that an unusual danger for autorotation exists.

2° owing to the small elevation of the plane, once a spin started it would be impossible for the pilot to recover.

The cable is a cause of considerable head resistance it may effect badly (L/D). That is why its cross section has to be reduced as much as possible. This means that we have to use a material of high tensile strength. Flexible steel cable of high tensile strength seems indicated. In order to reduce the air resistance a streamlined cable might be used. When tended between A and H the cable would bend around the axis of the smallest inertia moment of its cross section (Fig.11). This means that the axis XX will be horizontal. That is to say that the streamlined cable will automatically assume its position of lowest air-resistance. In horizontal projection the air speed will in general be nearly perpendicular to the cable.

As for the dimensions of the cable, they depend of course to a certain extent on the dimensions of the plane. A length of 50 yards would be a fairly represen-

tative figure. With a slope $\theta = 30^\circ$ this would correspond to an elevation of the plane of 25 yards.

In order to moderate the effects of sudden changes of forces we may attach the cable at both ends by means of some sort of a shock absorbing device.

The float, or as we may call it, the keel is the only new apparatus introduced by the sailing flight. We have to devote a little more detailed description to it. As first requirement we have to place as far as possible all parts creating head resistance out of the water. So has the connection between the cable and the keel to be above the surface. Fig. 12 shows schematically how this will be done: AB is a rigid member. The connection B is rigid and transmits a bending moment. The connection at the point of attachment A allows free rotation.

If all we have said about the theory of sailing flight has to have any value at all it is essential that S_k can keep a constant value or at least will oscillate in the neighborhood of a constant value. This we obtain by means of the simple scheme shown in Figure 12. The keel will consist of two parts BC and CD of different inclinations. As no moment can be transmitted through A, the keel will assume a position such that

the hydrodynamic force R_k passes through A. R_k can be decomposed into R_1 , due to the part BC and R_2 due to the part CD. R_1 creates a moment M_1 around A which tends to pull the keel out of the water. R_2 creates a moment M_2 which pulls the keel downward. Those two moments balance each other. If accidentally the immersed part of BC decreases, M_1 becomes smaller than M_2 and the float is pulled down. If it comes down too far M_1 surpasses M_2 and the float is pulled out again. A condition of dynamic equilibrium ensues.

In order to assure the constancy of the angle of attack of the keel, we shall provide it with a stabilizer S exactly as it is done with an airplane. The connection between the keel and the stabilizer will be above the water in order to reduce head resistance.

Giving the stabilizer the same shape as the keel we keep its immersed surface constant. So doing we oblige the leading edge of the keel to remain in a vertical plane, it is to say we prevent the whole device of tipping over around the axis AB.

One point remains to be solved: how shall we control the keel? The pilot being in the glider, the keel has to be operated from a distance. Consequently it will be important to simplify as much as possible the controls. In view of this fact we shall not attempt to

change the angle of attack of the keel while in flight. The angle setting of the stabilizer will be constant and such as to make the keel work as its greatest L/D.

Only two manoeuvres are left for the keel, to wit:

1° the regulating of the immersion.

2° the inversion.

We have at our disposal a very simple means of regulating the depth of immersion of the keel. It is sufficient indeed, to change the angle BCD of the two parts of the keel in order to make it dip down or come up. The smaller the angle BCD and the greater part of BC has to be under water in order to make R_1 pass through A. On the contrary when we make BCD large, R_1 will pass near A (Fig 12) and R_2 will have to be small.

In the disposition of Fig. 12, quite a moment would be required to make CD rotate around C. This is easily eliminated by hinging the lower part of the keel in the center of its span as shown in Fig. 13. In order not to have to transmit any control effort from the plane to the keel we could have the flap DD' change its own banking angle by means of the ailerons E and E' operated by the pilot.

Once the desired angle attained the ailerons would be brought back automatically to their neutral position by means of a very simple servo-mechanism such as that used in the Flettner rudder.

In order to maintain a constant ratio between the keel area and the immersed area of its stabilizer it will be necessary to equip the latter with an exactly similar device. Whenever we increase or decrease S_k the immersed stabilizer area will vary with a proportional amount.

The second manoeuvre the keel must be able to perform is the inversion. Let us see wherein it consists. Fig. 14 represents a sailing glider flying in the direction V_g . V_w is the prevailing wind. We see that the glider has its wing tip L down its wing tip R up. The keel has its tip L up its tip R down.

Now we want to fly in the direction V_g lying at the other side of the wind. The triangle of speed shows how this is to be done: we shall have to adopt the disposition of fig. 15. The glider has now tip L up and tip R down. The keel tip L down and tip R up. Both glider and keel have been inverted.

From this we conclude that the keel has to be bilateral. Only one half at a time has to be in the water, while the other half absolutely symmetrical to the first one will stick up in the air (Fig. 13)

The inversion of the glider does not entail any special difficulties, we simply pass through the horizontal position when going over from the left bank to the right bank. The inversion of the keel might be done in many conceivable ways. Practice will undoubtedly show what is the best method to execute the manoeuver. One possible way of doing it (which we give for what it is worth) would be to give suddenly to the keel flap DD' the position shown in fig. 16, and at the same time to move the stabilizer flap in the opposite direction. The keel would be drawn completely into the water whereas the tail would whip out. The whole thing would tip over in the direction shown by the arrow and would recover its equilibrium when the tail gets in the water again. Tip L will then be in the water and tip R up in the air. It is, of course, necessary to provide in A a joint that will permit rotation around the axis AB.

Chapter II

MANOEUVERING

10. Our new method of flying would not have any practical value at all if we were unable to take off to land or to fly in any desired direction of space. It is desirable also that we can control our speed at least in a certain range. Let us see how we shall meet those different requirements.

First of all how can we control the direction of flight. Looking at the triangle of speeds we see that, being given the direction of the wind W , we are able to change the direction of V by changing the ratio V/V_a . According to formula (2) this can be done either

1. by changing C_a and C_k that is by changing the angle of attack of the plane, of the keel, or both.

2. by changing the ratio S_a/S_k

The first method has the disadvantage of changing the fineness ratios. We could not maintain the greatest L/D and a loss of speed would result.

This disadvantage does not exist for the second method. The most practical way to control the ratio S_a/S_k is to act on S_k i.e. the immersion of the keel. As we have seen in paragraph 9 this can

be done with very simple means.

The procedure of changing the direction becomes then very simple. Suppose we are flying in the direction V_1 (Fig. 17) and we want to go over to the direction V_2 . We see that

$$\frac{V_1}{V_{a1}} > \frac{V_2}{V_{a2}}$$

$$\frac{V_1}{V_a} = \sqrt{\frac{S_a}{S_h}}$$

So, all we have to do is to decrease S_a/S_h that is to increase S_h . We gradually dip the keel deeper into the water until the desired direction is attained. It goes without saying that this manoeuver should become a reflex and that the pilot should not have to think in which way he is changing his triangle of speeds.

11.

This method of controlling the direction of flight is, however, subject to certain limitations. It is obvious, indeed, that we cannot change indefinitely the immersed area S_h . Consequently, there will be an angle LML (Fig. 17) within which it will be impossible to fly, exactly as it is the case with a sailing boat. Thanks to "tacking" we can overcome this difficulty.

Let us suppose we have to reach a point lying in the direction OD within the angle LML. We start with the velocity O, M. (If maximum speed is desired

O_1 will be situated on the circle of minimum φ). O_1M has a component perpendicular to MD: O_1P_1 . It means that the distance of the plane to the line MD is increasing with O_1P_1 per unit of time. After a certain time t_1 , this distance will be $t_1 \times O_1P_1$.

At this moment we reverse the triangle of speeds, i.e. we are going to fly in a direction that lies at the other side of the direction of the wind. Be O_2M our new velocity. It has a component perpendicular to MD: O_2P_2 . We are now approaching again the line MD at the rate of O_2P_2 per unit of time. Suppose we reach MD after a time t_2 .

Let us calculate now what has been our average speed in the direction MD:

$$V_{ave} = \frac{\text{total distance}}{\text{time}}$$

MP_1 and MP_2 being the components of the velocities O_1M and O_2M parallel to MD

$$\begin{aligned} V_{ave} &= \frac{t_1 \cdot MP_1 + t_2 \cdot MP_2}{t_1 + t_2} \\ &= \frac{t_1 \cdot MP_1 - t_1 \cdot MP_2 + t_2 \cdot MP_2 + t_1 \cdot MP_2}{t_1 + t_2} = MP_2 + \frac{t_1}{t_1 + t_2} (MP_1 - MP_2) \\ &= MP_2 + \frac{t_1}{t_1 + t_2} P_1 P_2 \quad (*) \end{aligned}$$

The fact that the line MD is reached after the total time $t_1 + t_2$ gives us the relation:

$$O_1 P_1 \cdot t_1 - O_2 P_2 \cdot t_2 = 0$$

whence:

$$\frac{O_1 P_1}{O_2 P_2} = \frac{t_2}{t_1}$$

Consequently, we can transform the last term of the expression (x):

$$\frac{t_1}{t_1 + t_2} P_1 P_2 = \frac{O_2 P_2}{O_1 P_1 + O_2 P_2} P_1 P_2 = P_2 P$$

as follows from the similarity of the triangles $O_1 P P_1$ and $O_2 P P_2$.

Whence

$$V_{ave} = P_2 M + P_2 P = P M$$

So, by tacking, the average speed made in a direction MD is represented by the vector PM contained between the point M and the straight line joining the extremities O_1 and O_2 of the vectors representing the two actual flying speeds of the manoeuvre $O_1 M$ and $O_2 M$.

It immediately follows that the greatest possible average speeds in tacking are obtained when $O_1 O_2$ coincides with the common tangent of the circles 1 and 2. What is more, if we consider a triangle of speeds, such as $MO_3 N$ where O_3 lies on the inner half of the circumference 1 or 2, we see that the actual

flying speed O_5M is smaller than the average speed we could make in the same direction by tacking. So, even in directions where tacking is not necessary for making flight possible, it may be interesting to apply it.

We can summarize the above in three practical rules:

1. When tacking the summit of the triangle of speeds should be placed alternately in either O_{t_1} and O_{t_2} or O'_{t_1} and O'_{t_2} . In other words, when tacking with the wind the two best directions of flight are $O_{t_1}M$ and $O_{t_2}M$. When tacking against the wind the two best directions of flight are $O'_{t_1}M$ and $O'_{t_2}M$.

2. Speed can be gained by tacking in all directions lying within the angles $O_{t_1}MO_{t_2}$ and $O'_{t_1}MO'_{t_2}$.

3. The closed curve $O_{t_1} O_{t_2} O'_{t_2} O'_{t_1}$ composed of the two exterior half circles (1) and (2) and the two common tangents $O_{t_1} O_{t_2}$ and $O'_{t_1} O'_{t_2}$ is, with M as origin, a polar diagram of the maximum speeds obtainable in all directions of space.

12. We have to study a little more closely the reversing manoeuver in tacking. Let us suppose we are tacking with the wind, the summit of the triangle of speeds being in O_{t_1} (Fig. 18). Reversing will consist in bringing the summit in O_{t_2} .

The way this manoeuver is done varies widely with the time in which it is to be accomplished. The more quickly the manoeuver is executed and the more important become the inertia forces. The latter completely modify the mechanism of the reversing.

As a limiting case we shall first study the case where the manoeuver is done in a very long time. In this case there are no inertia forces. The system will always be in static equilibrium. That means that it will never pass through any position in which flight cannot be maintained indefinitely.

The hypothesis of the total absence of inertia forces is, of course, purely theoretical, but it is conceivable that we approach this condition in practice.

The only way of bringing the summit of the triangle of speeds from O_{t_1} to O_{t_2} without disrupting the static equilibrium of the system, is to move it gradually along a path such as shown by the dotted line. This will be done by increasing φ . According to paragraph 9 φ_h is a constant. We have thus to change φ_a . The most practical way of doing this is to decrease the angle between the Y-axis (parallel to leading edge) of the glider and the horizontal as has been described in paragraph 8. I and II in

Fig. 19, show the orientation of the plane and the keel with air and water speeds corresponding to the positions of the summit of the triangle designated by I and II in Fig. 18. (We say the orientation of the glider and not the position because we are unable to draw the actual paths of A and H owing to the long time elapsed between I and II).

Continuing to increase φ_a the Y-axis gets finally horizontal (orientation III). We have:

$$\varphi_a = 90^\circ \quad \varphi = 90^\circ + \varphi_h$$

φ_a cannot be made any larger. But, in order to get the summit of the triangle of speeds in IV we have to make $\varphi = 180^\circ$. This can be obtained by letting the cable drag into the water. The enormous resistance so created will practically reduce to zero the L/D of the keel. Hence: $\varphi_h = 90^\circ \quad \varphi = 180^\circ$. In this position the glider will fly like a kite, i.e. the cable will assume the direction of the wind. It has to be remarked that the air speed V_a at this point will be very low. We will be able to get over this point only when a strong wind speed V_w prevails.

We now invert the keel as described in paragraph 9, the summit of the ^{triangle} v will get to V. As we

see in Fig. 19, the keel which was at the left hand side of the glider got to the right hand side. In order to restore normal flying conditions we have only to incline the Y-axis again - this time the left wing tip pointing down. By so doing we acquire gradually the positions VI and VII. The reversing manoeuver is completed.

The disadvantages of this method of reversing are obvious. In the first place we cannot get over the position IV unless we have a very strong wind at our disposal. In the second place, if we wish to avoid all inertia forces, we have to slow up the operation. That means that we have to fly a long time at speeds such as V_{II} , V_{III} , V_{IV} ... - which are small. It follows that the manoeuver entails a considerable loss in average speed. Because of these two disadvantages this method of reversing will be used seldom or not at all. We described it nevertheless for completeness, and because it gives a clear idea of what reversing really consists of.

13.

We shall now describe the method that will be generally used, i. e. the quick reversing in which considerable inertia forces will occur.

The general procedure to be followed remains the same as in the previous case, that is to say we go over from a left bank to a right bank and reverse

the keel at the moment the plane is in the horizontal position.

Let us call V the velocity of the center of gravity G of the system. It has to be brought from the value $O_{t_1} M$ to the value $O_{t_2} M$ (Fig. 20). Owing, however, to the inertia the variation of V will no longer be given by the curve I, II, III...of Fig. 18, but by some other curve I, II, III ...as shown in Fig. 20.

Let us call V_α the relative velocity of the air with respect to the glider.

V_{AG} the relative velocity of the glider with respect to the center of gravity.

V_{GH} the relative velocity of the center of gravity with respect to the keel.

V_h the relative velocity of the keel with respect to the water.

We have:

$$\overline{V_{AG}} + \overline{V_{GH}} = \overline{V_{AH}}$$

The distances AG and GH being constant V_{AG} and V_{GH} are both perpendicular to AH . As the horizontal projection of the cable may be supposed to remain a straight line,

V_{AG} and V_{GH} will be parallel and:

$$\frac{V_{AG}}{V_{GH}} = \frac{AG}{GH}$$

and:

$$\overline{V}_{AG} = \frac{AG}{AH} \overline{V}_{AH}$$

$$\overline{V}_{GH} = \frac{GH}{AH} \overline{V}_{AH}$$

From paragraph 7 we know that:

$$\overline{V}_a + \overline{V}_{AH} + \overline{V}_h - \overline{V}_w = 0$$

or:

$$\overline{V}_a + \overline{V}_{AG} + \overline{V}_{GH} + \overline{V}_h - \overline{V}_w = 0$$

Also:

$$\overline{V} = \overline{V}_{GH} + \overline{V}_h$$

Knowing V we can build the vector polygons those two relations. This has been done in Fig. 20 for the different values of V represented by IM , $II M$, $III M$, etc. By means of the velocities so obtained we have constructed the paths of the glider and the keel during the reversing, as shown in Fig. 21. We see that the glider has not to make a complete turn around its vertical axis as in the former case. The two disadvantages we mentioned in paragraph 12 have disappeared.

It has to be remarked that during the major part of the manoeuvre the system is just flying on acquired speed. It would not be possible to maintain for any length of time most of the positions assumed during the manoeuvre.

14. We have still to study the manoeuvres of landing and taking off. Landing will not entail any great difficulties. It will be possible in general to glide down against the wind.

At taking off, the glider will, of course, be in a horizontal position, consequently $\varphi_a = 90^\circ$. We turn the nose of the plane into the wind and let it drag the cable through the water. $\varphi_h = 90^\circ$ So:

$\varphi = 180^\circ$ we are in case IV of Fig. 18. When the prevailing wind is sufficient the plane can be lifted off the water. When we gain sufficient height, we raise the cable out of the water. At this moment

$\varphi = 90^\circ + \varphi_h$. We are in case III or V of Fig. 18 and 19. We can then get the system to the positions I or VII or give the triangle of speeds any desired form by banking the glider the necessary amount and dipping the keel to the required depth.

As we shall see in chapter III (paragraph 18) the above described method of take off will be rather unusual. In the more general case, the prevailing wind will not be strong enough to make possible the take off without outside help, though it will be perfectly sufficient to make normal flight possible. Two other methods of getting the glider in the air present themselves:

1. towing.
2. using an auxiliary motor.

In the first case the glider will be towed by the lower end of the cable against the wind (by a motor launch, for instance). The glider takes off, uses and raises the cable out of the water. At this moment the pilot banks the glider which will move to the side of the launch (instead of directly behind it). The cable can then be released and the flight will continue independently.

There now remains the case of the auxiliary motor. The pilot takes off in the usual way, towing the cable and the keel behind the plane. He rises, and as soon as the cable will be out of the water, the keel moves to the right or left of the plane. The pilot banks in the corresponding direction and stops the engine continuing in sailing flight.

Chapter III

STRESSES, TAKE-OFF, CAVITATION, AND
THEIR INFLUENCE ON SPEED

15. The glider to be used in sailing flight differs considerably from the ordinary plane in so far as its mechanical resistance is concerned. The forces involved in the case of sailing flight are much greater than those acting on the ordinary airplane. Indeed, in free flight, the total air force never exceeds the weight of the plane in normal conditions. This is no longer true for the sailing glider. As we have already seen in paragraph 8, the forces applied to the glider are threefold; to wit (1) the resultant air force R ; (2) the tension in the cable T , and (3) the weight W . (We suppose the weight of the cable included in W . T then will not be the actual pull of the cable in A , but only the pull transmitted from the float.) Figure 22 shows a typical proportioning of these three forces we have here: $R = 6W$.

Whereas in the ordinary airplane, we decrease the angle of attack when the speed increases,

in sailing flight the angle of attack is constant and equal to that of maximum L/D . Consequently, the air forces will increase as the square of the speeds.

It is obvious that the speeds increasing, a moment will arrive where the wing-loading will attain a critical value beyond which structural failure will occur. Once this resistance limit is attained we shall be obliged to decrease the angle of attack if we want to fly at still higher speed. When we do this we impair the L/D of the glider, φ will increase and a limitation of the speed V will ensue.

16. Let us find out what this limitation really amounts to. Be V , the greatest speed we can obtain with a wind V_w . According to formula (5) we have approximately:

$$V_1 = \frac{V_w}{\varphi_1}$$

(For simplicity we suppose $V \equiv V_a$ and $\varphi = \sin \varphi = \tan \varphi$)

According to formula (4)

$$\varphi_1 = \varphi_{a,1} + \varphi_{h,1} = \frac{1}{(L/D)_1} + \frac{1}{(L/D)_h}$$

We call $(L/D)_1$ the maximum fineness ratio of the plane.

A definite ratio exists between the maximum L/D of the

plane and that of the keel. Let us call it a. Then

$$\varphi_1 = \frac{1}{(L/D)_1} + \frac{a}{(L/D)_1} = \frac{1+a}{(L/D)_1} \quad (I)$$

So:

$$V_1 = \frac{1}{1+a} (L/D)_1 V_w \quad (II)$$

We know when an airplane flies at its greatest L/D its profile drag equals its induced drag:

$$c_p = c_{i1}$$

Consequently

$$(L/D)_1 = \frac{c_{L1}}{c_p + c_{i1}} = \frac{c_{L1}}{2c_p} \quad (III)$$

the subscript 1 always referring to the angle of attack corresponding to the maximum L/D.

Let us now suppose that the velocity V_{w1} , is of a magnitude such that the air force on the glider attains exactly the limit of structural resistance R_e . We shall have

$$R_e = \frac{1}{2} \rho S c_{L1} V_1^2 \quad (IV)$$

Let us now consider a second case where the existing wind speed V_{w_2} is greater than V_{w_1} . If we flew the glider at the same angle of incidence the resistance limit R_l would be exceeded. We suppose that after cutting down the lift coefficient of the plane to the value C_{L_2} the maximum speed V_2 attainable with the new angle of attack will again give an air force equal to the limit of the structural resistance of the plane.

$$R_e = \frac{1}{2} \rho S C_{L_2} V_2^2 \quad (V)$$

Let α be defined as:

$$C_{L_2} = \frac{C_{L_1}}{\alpha}$$

Then (IV) and (V) give:

$$\frac{1}{2} \rho S C_{L_1} V_1^2 = \frac{1}{2} \rho S \frac{C_{L_1}}{\alpha} V_2^2$$

whence:

$$V_2 = \sqrt{\alpha} V_1 \quad (VI)$$

Let us now find how the ratio α depends upon the ratio $\frac{V_{w_1}}{V_{w_2}}$. How is φ affected by the adoption of the new angle of attack? We may assume that the profile drag coefficient of the plane did not change. The induced drag is known to be proportional to the square of the lift. So:

$$C_{I_2} = \left(\frac{C_{L_2}}{C_{L_1}} \right)^2 C_{I_1} = \frac{1}{\alpha^2} C_{I_1} = \frac{1}{\alpha^2} C_p$$

It follows that:

$$\left(\frac{L}{D}\right)_2 = \frac{c_{L2}}{c_p + c_{I2}} = \frac{\frac{c_{L1}}{2c}}{\left(1 + \frac{1}{2x}\right)c_p} = \frac{c_L}{\left(x + \frac{1}{2}\right)c_p} = \frac{2x}{x^2 + 1} \left(\frac{L}{D}\right)_1$$

From which we deduce φ_2 :

$$\varphi_2 = \varphi_{a2} + \varphi_h = \frac{x^2 + 1}{2x \left(\frac{L}{D}\right)_1} + \frac{a}{\left(\frac{L}{D}\right)_1} = \frac{x^2 + 2ax + 1}{2x} \frac{1}{\left(\frac{L}{D}\right)_1}$$

Whence

$$V_2 = \frac{\bar{V}_{w2}}{\varphi_2} = \frac{2x}{x^2 + 2ax + 1} \left(\frac{L}{D}\right)_1 \bar{V}_{w2}$$

Formula (VI) becomes then:

$$\frac{2x}{x^2 + 2ax + 1} \left(\frac{L}{D}\right)_1 \bar{V}_{w2} = \sqrt{x} \cdot \frac{1}{1+a} \left(\frac{L}{D}\right)_1 \bar{V}_{w1}$$

and

$$\frac{\bar{V}_{w2}}{\bar{V}_{w1}} = \frac{x^2 + 2ax + 1}{2\sqrt{x} (1+a)} \quad \text{(VII)}$$

By means of formulae VI and VII we can now plot V against V_w upward from the critical point C below which the structural resistance limit is not attained. This has been done in Figure 23. ^{for $a=1$} The dotted line gives the theoretical speeds we could attain if structural failure were not to be feared.

17. The graph of figure 23 is of great importance in the study of the performances of the sailing glider. It gives for every prevailing wind speed the corresponding maximum speed attainable. We shall call it the characteristic curve of the glider. In the previous paragraph we only considered the portion of the curve beyond the critical point C. Let us now study the portion below C.

If no weight had to be carried φ would be constant, V would be proportional to V_w and the characteristic curve would be a straight line below C. We have seen, however, in paragraph 8 that the relative importance of the weight of the plane with respect to the magnitude of the air forces greatly affects φ .

Let us suppose that at the critical point C the air force amounts to 6 times the value of the weight

$$R_c = 6W$$

6 will be a coefficient characteristic of the structure of the glider we shall call it the amplification factor

Let (fig. 22) be $T_h = R_y = \alpha_1 W$

Let us suppose the slope of the cable is $\theta = 30^\circ$

then

$$T_v = \tan 30^\circ T_h = \sqrt{\frac{1}{3}} \alpha_1 W$$

and

$$R_s = \left(1 + \sqrt{\frac{1}{3}} \alpha_1\right) W$$

If we now disregard R_x which is comparatively small, we have (fig. 22):

$$R_l^2 = R_y^2 + R_z^2$$

or

$$36 W^2 = \alpha_1^2 W^2 + (1 + \sqrt{\frac{1}{3}} \alpha_1)^2 W^2$$

simplifying

$$\frac{4}{3} \alpha_1^2 + \sqrt{\frac{4}{3}} \alpha_1 - 35 = 0$$

resolving for α_1 :

$$\alpha_1 = \frac{-\sqrt{\frac{4}{3}} + \sqrt{\frac{4}{3} + 4 \cdot \frac{4}{3} \cdot 35}}{2 \cdot \frac{4}{3}} = 4.7$$

consequently

$$\varphi_{a_1} = \frac{R_x}{R_y} \approx \frac{R_l}{(L/D)_a R_y} = \frac{6W}{4.7W (L/D)_a} = 1.28 \frac{1}{(L/D)_a}$$

According to paragraph 8 we have approximately

$$\varphi_h = \frac{1}{(L/D)_h} \sec \theta = 1.15 \frac{1}{(L/D)_h}$$

Supposing now, as we did in the previous paragraph

$(L/D)_a = (L/D)_h$ we have

$$\varphi_1 = \varphi_{a_1} + \varphi_h = (1.25 + 1.15) \frac{1}{L/D} = 2.43 \frac{1}{L/D}$$

Let us now assume that the air speed decreases to one-half of its value and let us find to what wind speed this new V will correspond in the characteristic curve. When the air speed is reduced to $\frac{1}{2}$ the air forces

are divided by four. So:

$$R = \frac{1}{4} R_e = \frac{1}{4} \times 6W = \frac{3}{2} W$$

Hence, as shown in Fig. 24:

$$\left(\frac{3}{2}\right)^2 W^2 = \alpha_2^2 W^2 + \left(1 + \sqrt{\frac{1}{3}} \alpha_2\right)^2 W^2$$

or:

$$\frac{4}{3} \alpha_2^2 + \sqrt{\frac{4}{3}} \alpha_2 - \frac{5}{4} = 0$$

resolving for α_2

$$\alpha_2 = \frac{-\sqrt{\frac{4}{3}} \pm \sqrt{\frac{4}{3} + 4 \cdot \frac{4}{3} \cdot \frac{5}{4}}}{2 \times \frac{4}{3}} = .62$$

and:

$$\varphi_{a_2} = \frac{R_e}{R_y} \approx \frac{R_e}{\left(\frac{L}{D}\right)_a R_y} = \frac{\frac{3}{2} W}{.62 W \left(\frac{L}{D}\right)_a} = 2.4 \frac{1}{\left(\frac{L}{D}\right)_a}$$

φ_h remained the same, consequently:

$$\varphi_2 = \varphi_{a_2} + \varphi_h = (2.4 + 1.15) \frac{1}{\left(\frac{L}{D}\right)_a} = 3.55 \frac{1}{\left(\frac{L}{D}\right)_a}$$

In the first case we had:

$$V_1 = \frac{1}{2.43} \frac{L}{D} V_{w_1}$$

In the second:

$$V_2 = \frac{1}{3.55} \frac{L}{D} V_{w_2}$$

By hypothesis:

$$V_2 = \frac{1}{2} V_1$$

we conclude

$$V_{w_2} = \frac{3.55}{2.43} \frac{V_{w_1}}{2} = 1.46 \frac{V_{w_1}}{2}$$

The point (V_{w_2}, V_2) in the characteristic curve will be D. (Fig. 23). So we see that the curve lies underneath the straight line of the theoretical case. When we continue

to decrease V_w the characteristic gets tangent to a parallel to the V-axis in a point B. This point corresponds to the minimum wind speed at which flight is possible.

18. The position of the critical point C depends on the wing area, the limiting wing loading, and φ . The length of the portion CB depends on the amplification factor. The greater this factor and the larger will be BC. Once we have C and the amplification factor, the whole characteristic curve is defined.

The characteristic curve gives us immediately the speed range of the glider. In Fig. 24 are shown three different characteristic curves. They all correspond to an amplification factor 6 and to $\varphi = 5$.

The curve 1 corresponds to a glider of small wing area. This glider will be able to fly at very high speeds. With a gale of 40 miles per hour, it will make 180 m.p.h. However, it needs already a fresh breeze in order to be able to stay in the air. The minimum wind speed permitting the flight (given by point B) is only 18 miles per hour. As we have only such a wind at our disposal a few days in a year, the plane will be unable to fly most of the time. In some regions, however, strong winds may be more frequent or even usual, in such conditions it would be logical to adopt this type of characteristic curve for the sailing glider.

Looking at it from the view point of the take off we see that it would be quite out of the question to start this type of plane by the sole force of the wind, that is to say without towing or without auxiliary engine, indeed, the landing speed of the plane is around 45 m.p.h. That means that we would have to wait for a wind of about 60 m.p.h. before we could go up.

Condisering the glider corresponding to a curve 2 we see that it will be able to keep the air with a gentle breeze of about 7m. p.h. The attainable speeds of this machine are, however, much smaller than those of the glider of the former case. With a gale of 40 miles it will only make a 110 m.p.h. This type of glider, that is the one which reaches its critical point at a wind of 10 m.p.h. seems very well suited for the atmospheric conditions prevailing in these latitudes. Indeed the most frequent wind speeds of those regions - 8 to 25 m.p.h. - lie within its useful range. It gives the reasonable speed of 50 m.p.h. with a ten mile wind and of about 70 m.p.h. with a fifteen mile wind.

The landing speed of this machine is approximately 16 m.p.h. We need a strong gale for taking off without outside help. So again, as a rule, we must have recourse either to towing or to an engine for starting the flight. Which of these two methods should we prefer? Each of them has an advantage and a disadvantage. The

advantage of the engine is, of course, to make the machine independent. This is why it should be used in long raids. Whenever the machine has come down, whether because of insufficient wind or from any other cause, it will be able to take off again as soon as atmospheric conditions permit. The disadvantage of the engine is that it increases considerably the weight of the plane and adds to the cost.

One advantage of the towing start is that it permits the increase of L/D of the glider. The most important advantage, however, is that it eliminates the weight of the engine. By this very fact the amplification factor is increased. We can either let the structure of the glider remain as it was and bring down the point B of the characteristic curve, that is lessen the probability of being forced down by lack of wind. Or we can use the weight saved on the engine for reinforcing the wing structure. By doing this we raise the critical point C and all the speeds beyond.

The disadvantage, of course, is that once we are forced down by feeble winds, it is virtually impossible to again leave the water. Consequently this method should be used only for short hops when the pilot is always sure to find sufficient winds ahead.

Curve 3 of figure 24 finally, is the characteristic curve of a glider that has been constructed so as to be able to leave the water by its own means. That is to say, a glider with ^{very} large wing area. The landing speed has been chosen 6 m.p.h. so that the take off will be possible at a slight breeze of 8 m.p.h. We reach the critical point at a wind-speed of 3.5 m.p.h. The speeds we can attain with a plane like this are exceedingly low. With a wind of 10 m.p.h. our maximum speed will be only 34 m.p.h. In order to be able to fly at 50 m.p.h. we need a wind of 26 m.p.h. These figures could be bettered by increasing the fineness ratios and the amplification factor. Supposing we can get the latter up to 8 and make $\varphi = 6$ the new characteristic curve will be given by the dotted line.

19. It will be interesting to consider those three types of gliders from the viewpoint of wing areas and wing loadings. We shall admit that the lift coefficient of the glider at its greatest L/D is $C_L = 1$. This cannot be very far from the truth.

Let us first take the case of the fast glider. It attains its critical point at an air speed of 125 m.p.h. Consequently its maximum wing loading will be :

$$125^2 \times .00255 \times 1 = 40\#/ft^2$$

Unlike what is the case for the ordinary airplane, the wing loading of the sailing glider does not express the ratio $\frac{\text{weight}}{\text{wing area}}$. We obtain this ratio by dividing the maximum wing loading by the amplification factor. In this case

$$\text{weight per sq. ft} = \frac{40}{6} = 6.7\#$$

We see that the wing area will not be very different from that used in an ordinary airplane of the same total weight. The wing weight will be greater than in the ordinary plane as the structure will have to sustain loads as high as $40\#/ft^2$. (It is evident that in the stress calculations this load has still to be multiplied by the load factor as usual.) When applying Professor Warner's formula

$$W_w = k A^7 P^{.44} R^{.24}$$

we find a wing weight $6^{.44} = 2.2$ times that of the airplane with wing loading $6.7\#/ft^2$.

In the second case the critical point corresponds to the speed of 50 m/p.h. The critical wing loading is:

$$50 \times .00255 \times 1 = 6.4\#/ft^2$$

$$\text{the weight per sq. ft.} = \frac{6.4}{6} = 1.1\#$$

In other words, the wing area will be about ten times that of an ordinary plane of the same weight. In order to keep down the wing weight we shall have to transmit the pull of the cable directly to the wings in

2 or more points conveniently situated along the span, rather than to create excessive bending moments by applying it on one point at the centre. The estimation of the wing weight then becomes difficult. It would require a detailed structural analysis. The use of the triplane cellule may be necessary in view of the enormous wing area.

Coming now to the case of the glider that will take off in a slight breeze, we find wing areas absolutely prohibitive. This case has to be abandoned. We cannot hope to build up sailing gliders that will take off at such small wind speeds without outside help.

20. If the cable is efficiently designed, it should reach its limit of permissible stress at the same moment as the plane. Consequently the cross-section of the cable and its weight will be directly proportional to the amplification factor.

The weight of the cable is rather small. In the specifications of the British Air Board (Pippard & Pritchard), we find that an extra flexible steel rope of .388 inch diameter has a minimum breaking strength of 15,700 lbs. and weight 25.5 lbs. per 100 feet. This cable applied to a glider of 1,000 lbs. flying with an

amplification factor 6 would still have a safety factor of 2.6. Fifty yards would weigh 38 lbs., that is to say, only 3.8% of the total weight.

The shape of the cable is a catenary practically reduced to a straight line. Indeed, if T is the traction in the cable at its lower end, T' the traction at the upper end and w its weight.

$$\overline{T'} = \overline{T} + \overline{w}$$

w being only about .6% of T , the directions of T and T' are practically the same.

21. There will be no difficulty in making the keel strong enough to resist to the hydrodynamic forces. There is, however, another reason for limiting the loads per unit area, namely cavitation. If the water pressure gets too low, gas pockets will be formed, the continuity of flow will be destroyed. The keel loses its efficiency and increases. Consequently, cavitation is something we have to avoid by all means. This can only be done by keeping the keel-loading below a certain limit. To what just this limit will amount is difficult to say and could only be determined by experiment. It seems, however, that the conditions are less favorable for cavitation than those prevailing with the marine propeller. In the latter case indeed, each blade has to work in a

portion of the fluid that has already been disturbed by the preceding one. Nothing of the sort happens in the case of the keel. The fluid passes through the low pressures only once and during a very short time. Owing to the rapidity of this phenomenon, probably only a small amount of the gases included in the water have time to liberate themselves. A keel loading of $1000\#/ft.^2$ (i.e. 47% of the atmospheric pressure) seems a reasonable limit not to surpass.

Once we attain this limit, we have to decrease the lift coefficient of the keel if we still want to reach higher speeds. The case is absolutely similar to that of the glider when it reaches its structural resistance limit. Here again we shall have a critical point. We shall call it the cavitation point. Above this cavitation point (Fig. 25) the characteristic curve will be affected, exactly in the same way it is above the critical point C, by the fact that the keel does not maintain its angle of attack of maximum L/D . (Paragraph 16) Unlike the critical point, however, the cavitation point does not depend on the amplification factor nor on the keel area. Once the keel section determined the ordinate of D is the same in all characteristic curves. Let us find this ordinate.

The assumption we made in paragraph 4 that when both cellules A and H work at their angle of attack of greatest L/D $c_{L_a} - c_{L_h}$ holds only in the theoretical case. In the practical case where ρ_a is so much smaller than ρ_w we remove all the profile resistance we possibly can from the water and place it in the air. We have seen that the keel has no profile resistance whatsoever except that of the air-foils it is composed of themselves. So: $c_{p_a} > c_{p_h}$ But as the profile drag equals the induced drag at greatest L/D, $c_{i_a} > c_{i_h}$ The induced drags being proportional to the squares of the lifts we conclude $c_{L_a} > c_{L_h}$.

Let us suppose that at maximum L/D the keel lift coefficient is:

$$c_{L_h} = .5$$

(a rather conservative assumption). Adopting then as limiting keel loading $1000\#/ft^2$ we find for the speed at the cavitation point:

$$V_D = \sqrt{\frac{(F/S)_h}{\frac{1}{2} \rho_w c_{L_h}}} = 31 \text{ m.p.h.}$$

Let us find now how the characteristic curve is affected. Considering a speed V_2 such that

$$V_2 = \sqrt{x} V_D$$

we have, according to paragraph 16:

$$\left(\frac{L}{D}\right)_{h_2} = \frac{2x}{x^2+1} \left(\frac{L}{D}\right)_{h_D}$$

whence :

$$\varphi_2 = \varphi_{a_2} + \varphi_{h_2} = \frac{1}{\left(\frac{L}{D}\right)_1} + \frac{x^2+1}{2x \left(\frac{L}{D}\right)_{h_D}}$$

where $(L/D)_1$ is the maximum L/D of the glider. We know that $(L/D)_{h_D}$ is the maximum L/D of the keel. We have already seen that the L/D of the keel will be greater than that of the glider as the latter presents more parasite resistance: Let us suppose:

$$\left(\frac{L}{D}\right)_{h_D} = 2 \left(\frac{L}{D}\right)_1$$

then:

$$\varphi_2 = \frac{1}{\left(\frac{L}{D}\right)_1} + \frac{x^2+1}{4x \left(\frac{L}{D}\right)_1} = \frac{x^2+4x+1}{4x} \frac{1}{\left(\frac{L}{D}\right)_1}$$

If we make $V_2 = V_c$ we can deduce the corresponding x , whence φ_c and

$$\overline{V}_{w_c} = \varphi_c \overline{V}_c$$

Let us do this for the glider corresponding to the No. 2 characteristic curve of figure 24. We have $V_c = 50$ m.p.h. So:

$$x_c = \left(\frac{\overline{V}_c}{\overline{V}_D}\right)^2 = \left(\frac{50}{31}\right)^2 = 2.6$$

whence:

$$\varphi_c = \frac{\alpha_c^2 + 4\alpha_c + 1}{4\alpha_c} \frac{1}{\left(\frac{L}{D}\right)_1} = 1.75 \frac{1}{\left(\frac{L}{D}\right)_1}$$

In diagram 24 we supposed $\varphi = 1/5$, that is to say:

$$\frac{1}{\left(\frac{L}{D}\right)_1} + \frac{1}{\left(\frac{L}{D}\right)_{hD}} = \frac{1}{\left(\frac{L}{D}\right)_1} + \frac{1}{2\left(\frac{L}{D}\right)_1} = \frac{3}{2\left(\frac{L}{D}\right)_1} = \frac{1}{5}$$

whence:

$$\frac{1}{\left(\frac{L}{D}\right)_1} = \frac{2}{15}$$

and:

$$\varphi_2 = 1.75 \times \frac{2}{15} = .233$$

and:

$$\bar{V}_{w_c} = .233 \bar{V}_c = 11.3 \text{ m.p.h.}$$

We see that the influence of the existence of the cavitation point has been to increase the critical wind speed.

The behavior of the characteristic curve above the critical point is found in the same way. Let us consider a certain speed $V_3 > V_c$. We want to find to what wind speed it corresponds. Again we assume:

$$\bar{V}_3 = \sqrt{\alpha_1} \bar{V}_c = \sqrt{\alpha_c \alpha_1} \bar{V}_D$$

According to paragraph 16:

$$\begin{aligned} \varphi_3 = \varphi_{a_3} + \varphi_{h_3} &= \frac{\alpha_1^2 + 1}{2\alpha_1 \left(\frac{L}{D}\right)_1} + \frac{\alpha_1^2 \alpha_c^2 + 1}{2\alpha_1 \alpha_c \left(\frac{L}{D}\right)_{hD}} = \\ &= \left(\frac{\alpha_1^2 + 1}{2\alpha_1} + \frac{\alpha_1^2 \alpha_c^2 + 1}{4\alpha_1 \alpha_c} \right) \frac{1}{\left(\frac{L}{D}\right)_1} \end{aligned}$$

So:

$$\bar{V}_{w_3} = \left(\frac{\alpha_c^2 + 1}{2\alpha_c} + \frac{\alpha_c^2 \alpha_c^2 + 1}{4\alpha_c \alpha_c} \right) \frac{1}{(\frac{L}{D})_1} \bar{V}_3$$

We found:

$$\bar{V}_{w_c} = 1.75 \times \frac{1}{(\frac{L}{D})_1} \bar{V}_c = \frac{1.75}{(\frac{L}{D})_1} \frac{\bar{V}_3}{\sqrt{\alpha_c}}$$

So:

$$\bar{V}_{w_3} = \left(\frac{\alpha_c^2 + 1}{2\alpha_c} + \frac{\alpha_c^2 \alpha_c^2 + 1}{4\alpha_c \alpha_c} \right) \frac{\sqrt{\alpha_c}}{1.75} \bar{V}_{w_c}$$

Or, replacing α_c by its value:

$$\bar{V}_{w_3} = \frac{.66 \alpha_c^2 + .34}{\sqrt{\alpha_c}} \bar{V}_{w_c}$$

This formula has been applied to find the characteristic curve 2 of Fig. 25. We see that curve 1 lies entirely beyond the cavitation point. This curve also has been established with formulae similar to those of case 2.

22. The characteristic curves all refer to conditions of maximum speed, that is, to the case where $V_a = V_h$, corresponding to a direction of flight near to the perpendicular to the prevailing wind direction. If now for a given wind we reach the stress or cavitation limits when flying perpendicularly to it, this does not mean that we reach those limits when flying in the other direction of space. For those latter directions it may be quite possible to maintain the smallest possible value for φ . As we will be obliged to use less favorable values of φ in the directions of highest speeds, it is obvious that a deformation

of the polar diagram of speeds of figure 17 will ensue. Fig. 26 represents this speed diagrams for the glider we called No. 2 in the above paragraph. The wind-speeds chosen are:

1. The windspeed of the cavitation point.
2. The wind speed of the critical point.
3. A wind speed of three times the critical wind speed.

23. The lowering of the lift coefficient of the keel after the cavitation point has been reached can only be done by changing the stabilizer angle. In order not to complicate the operation of the keel, this stabilizer adjustment will be done automatically. A simple mechanism can be devised for this, which will go into action as soon as the keel-loading reaches its greatest permissible value. The use of the Flettner rudder principle seems once more indicated.

It would even be possible to provide the glider with an exactly similar device so that it will be impossible that the pilot increases unknowingly the stresses beyond the resistance limit.

In order to keep down the cavitation point D it is essential that the lift coefficient of the keel corresponding to the maximum L/D be as small as poss-

ible. This can be obtained by reducing to a strict minimum the profile drag of the keel. It means that we shall have to use an airfoil section as thin as the structural resistance will permit. In view of this fact we shall have to aim at the highest possible structural efficiency of the keel. We shall adopt a tapered plan form (Fig. 13) and only a moderate aspect ratio. The material will be high tensile stress steel. The section will be full. It is, however, desirable that the keel has enough buoyancy to keep it ^{self}afloat while at rest. This buoyancy will be given to the body KS (Fig. 13) we might call the fuselage of the keel.

Let it be remarked that we have no longer as in the theoretical case:

$$\frac{S_a}{S_h} = 800$$

but rather:

$$\frac{S_a c_{L_a}}{S_h c_{L_h}} = 800$$

which at the cavitation point means:

$$\frac{S_a}{S_h} = 400$$

At the critical point of glider No. 2 we have:

$$\frac{S_a}{S_h} = 150$$

At the critical point of glider No. 1:

$$\frac{S_a}{S_h} = 15$$

Chapter IV.

POSSIBILITIES OF THE SAILING FLIGHT

24. We have already shown in paragraph 18 the performances we may expect from the sailing glider. The figures of paragraph 18 need, however, a little correction as we did not take into account the possibility of cavitation. The corrected performances are given in Fig. 25. These performance calculations are based on rather conservative assumptions, so that in reality we will most probably be able to obtain even better results. A certain number of the data we used in our calculations can only be furnished by experiment. We preferred to remain at the safe side when estimating their value. Let us consider a little more in detail these different assumptions.

1. We first supposed $\varphi = 1/5$ and $\varphi_a = 2/3\varphi = 2/15$. This corresponds to a fineness ratio for the plane of:

$$\left(\frac{L}{D}\right)_a = \frac{\sec \theta}{\varphi_a} = 8.6$$

Evidently this figure can much be bettered.

It is true that the cable and the part of the keel that sticks out of the water

create quite some head resistance, but, on the other hand, the fact that the wing area is unusually large diminishes the relative importance of the parasite resistance.

2. We admitted $\varphi_n = 1/3 \varphi = 1/15$. This means:

$$\left(\frac{L}{D}\right)_n = \frac{\sec \theta}{\varphi_n} = 17.3$$

We know that for thin wing sections such as those used in the keel, the L/D ratio can go up to 25 and higher. Two circumstances, however, will tend to decrease this high fineness ratio. In the first place we have the resistance due to the creation of surface waves. In the second place we have to remember that the keel is working at a very low Reynold's number. Indeed $R = \rho \frac{Vl}{\mu}$ the linear dimensions l are very small and the specific viscosity ν/ρ is large. Nevertheless, we think that estimating the decrease in L/D at 30% is staying at the safe side.

3. A third assumption we made is that the maximum L/D of the plane will correspond to a lift coefficient $C_{L_{\alpha}} = 1$. This is certainly too high. The result is that the critical

point C is really higher than we assumed. At the same time the ratio $C_{Lmax}/C_{Lnormal}$ is increased so that the minimum speed of flight (point B) is brought down.

4. Similarly we supposed that $(L/D)_h$ would be maximum for $C_{Lh} = .5$. This again has probably been estimated too high. The result is that the cavitation point will be reached well above 31 m.p.h. We see that all of these four assumptions tend to give us speeds which are lower than those actually attainable in practice. Finally these speeds could still be raised a little by decreasing the slope of the cable .

25. The greatest advantage of the sailing flight is that it has a practically unlimited endurance. We can keep in the air as long as we have sufficient wind. The sailing glider could consequently be used for long raids. The crossing of the Atlantic or the Pacific, for instance, would be possible. In those parts of the world where constant winds prevail, such as the trade winds or the mossoons, the sailing plane can be used commercially. On the other hand, it is doubtful if any

commercial exploitation would be possible in places such as the Northern Atlantic where winds may vary widely in direction and intensity. A lack of reliability might indeed be too great a drawback in commercial aviation.

The type of glider we characterize with No. 1 has a wing loading not far from that adopted in the ordinary plane. The minimum permissible wind speed has been found 18 m.p.h. while actually it will probably be lower. At this speed we fly about in the position given by the third sketch of Fig. 10 consequently, R_a is not much larger than W , so that a plane built with the ordinary load factor can resist to it. The tension T too is small, and as we are near the cavitation point only a small keel area is needed. If the plane had to fly in this position only, both the cable and the float could be made very light. In view of these facts, it is conceivable that a motor driven plane which has to cross large stretches of water takes along a small cable and float as a safety device. In case of motor trouble or exhaustion of fuel the plane could continue in sailing flight whenever it has a wind not under 18 m.p.h.

The largest possibilities for sailing flight, however, are probably in sport. Long distance sailing would certainly be a most exciting adventure. In races the personal skill of the pilot would play a much more prominent part than is the case in ordinary airplane races.

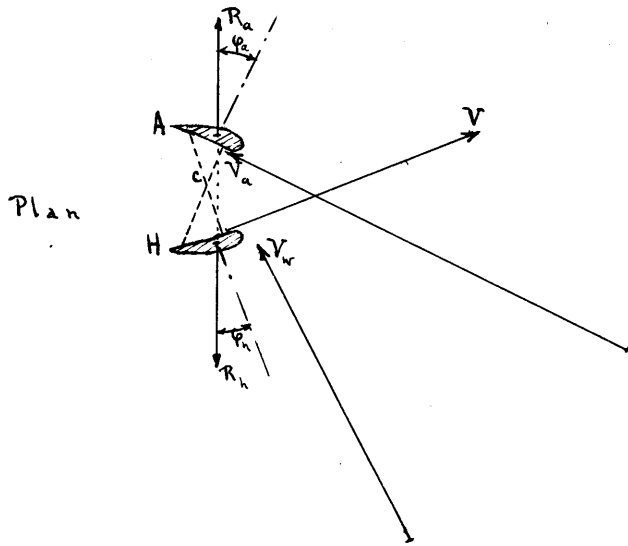
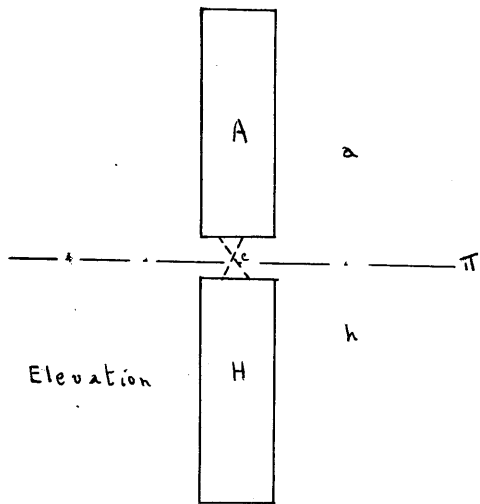

Fig. 1

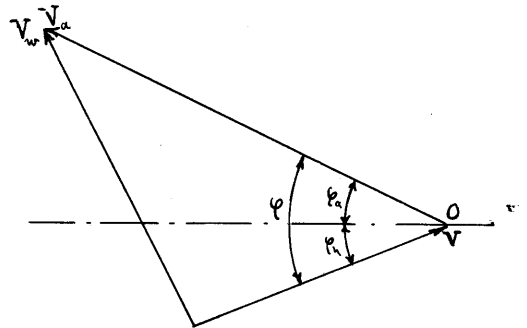

Fig 2.

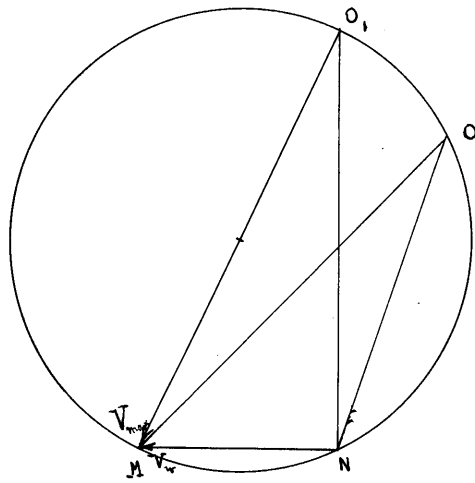

Fig. 3

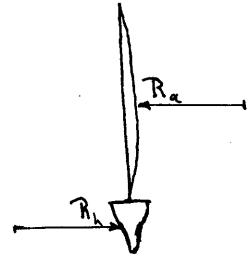

Fig. 4

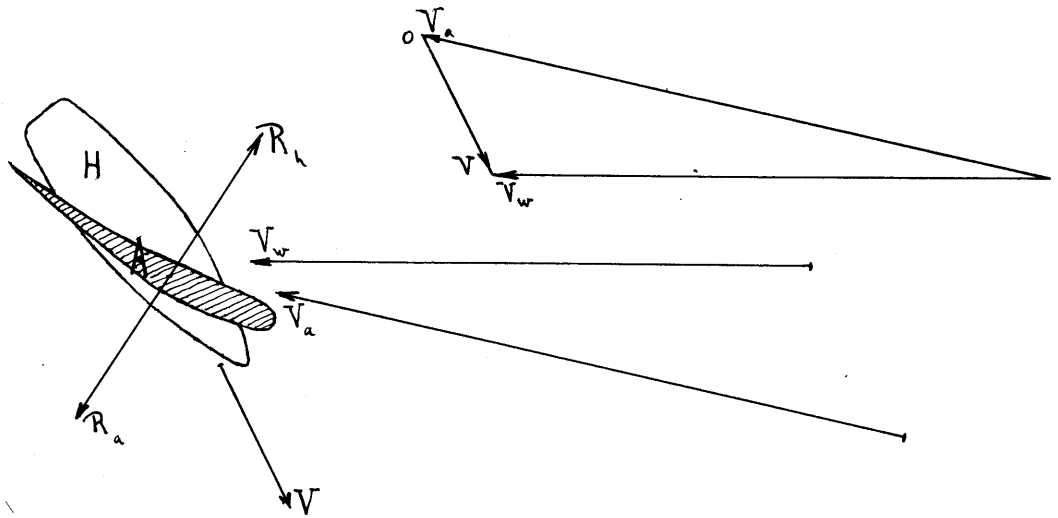

Fig. 5

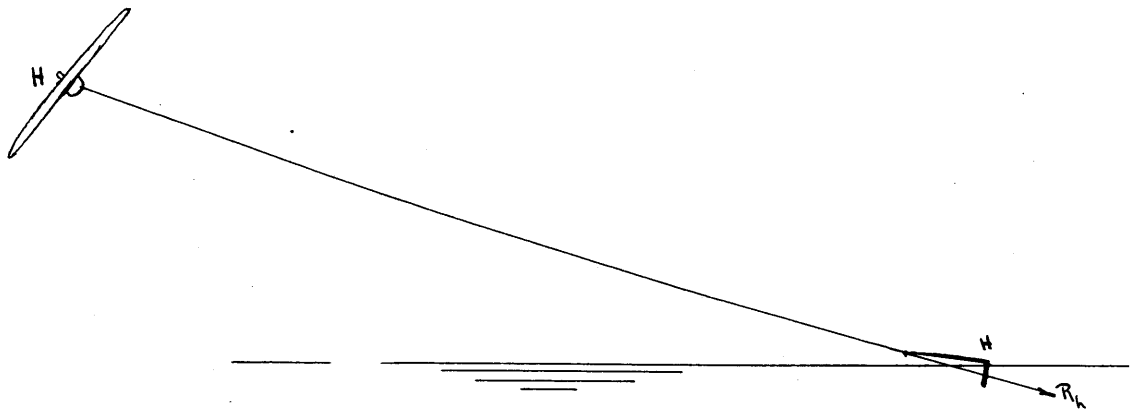

Fig. 6

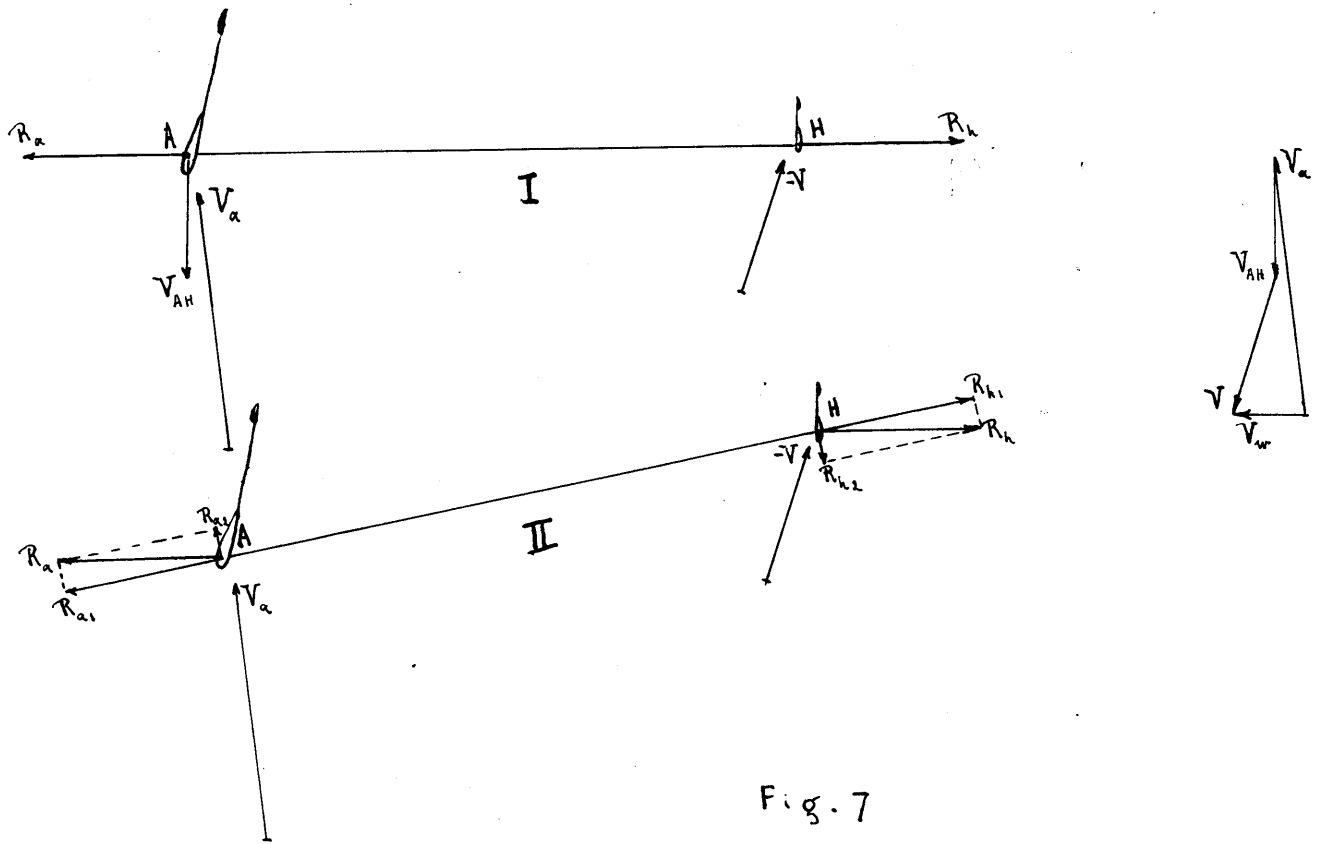

Fig. 7



Fig. 8

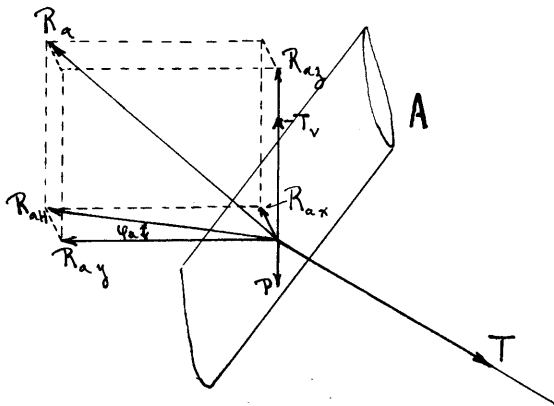
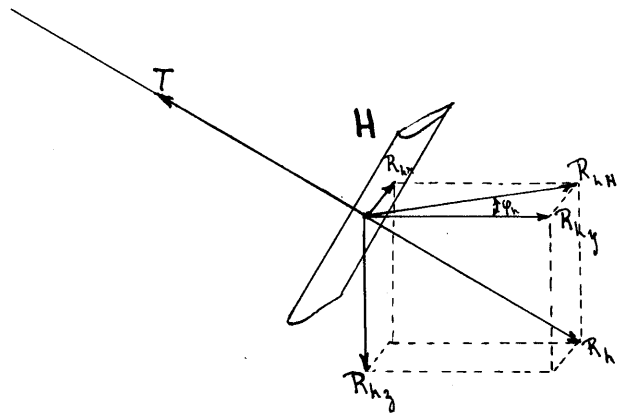
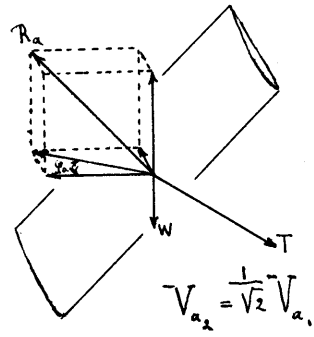
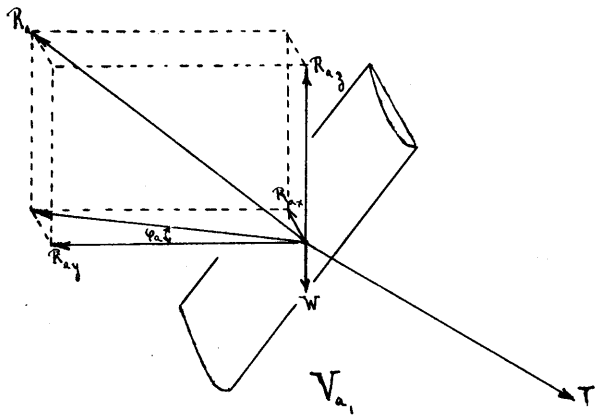
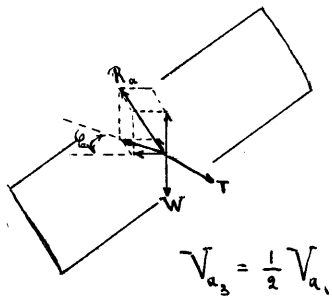

Fig. 9





$$V_{a_2} = \frac{1}{\sqrt{2}} V_{a_1}$$



$$V_{a_3} = \frac{1}{2} V_{a_1}$$

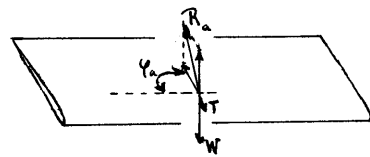

$$V_{a_4} = \frac{2}{5} V_{a_1}$$

Fig. 10

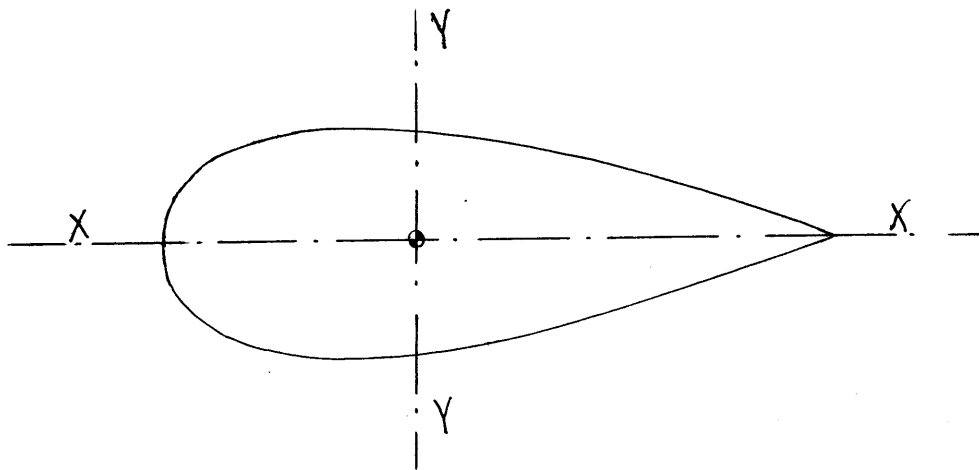

Fig. 11

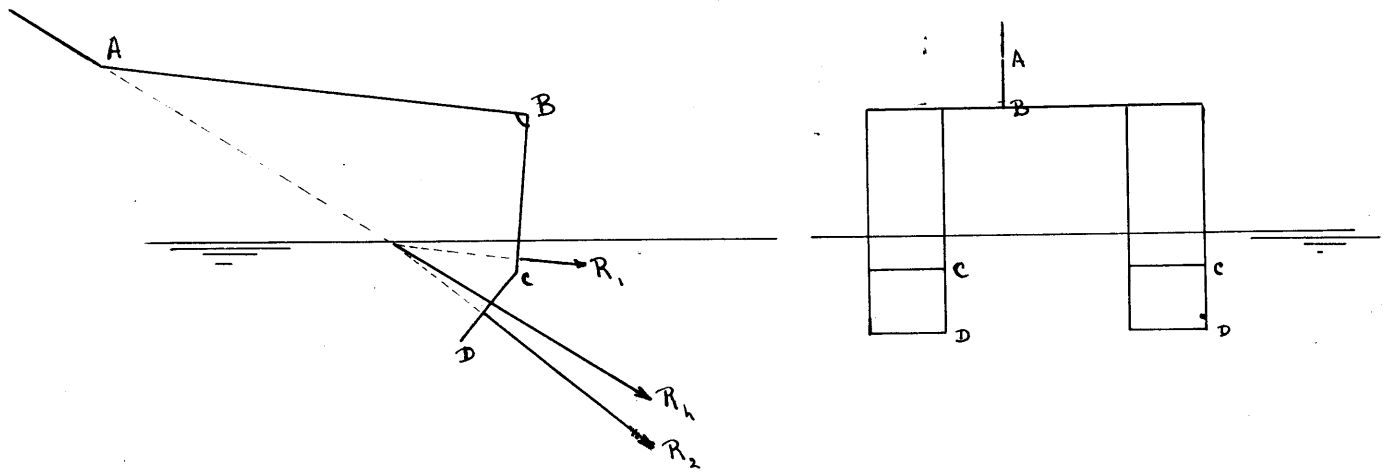

Fig. 12

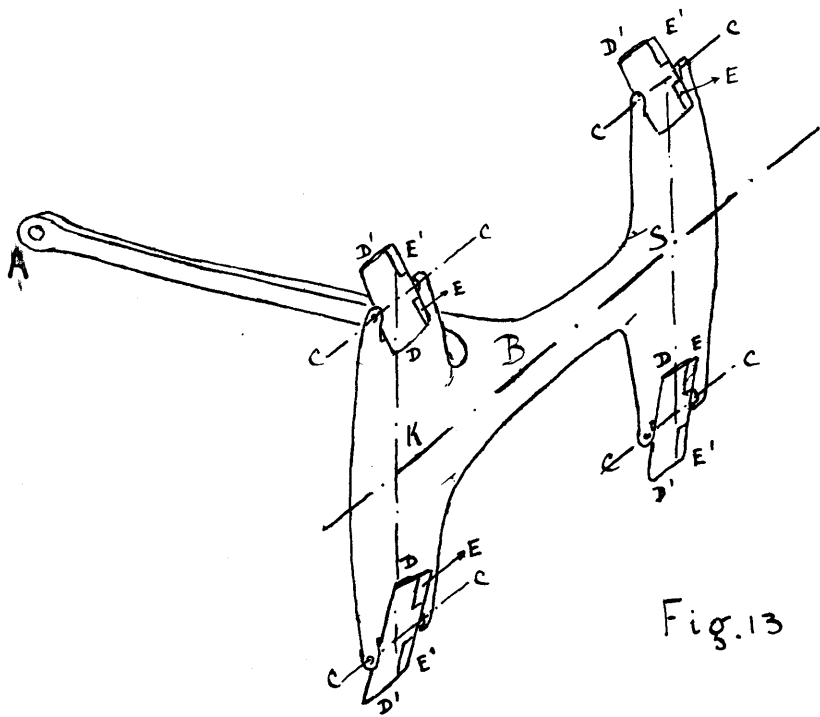

Fig. 13

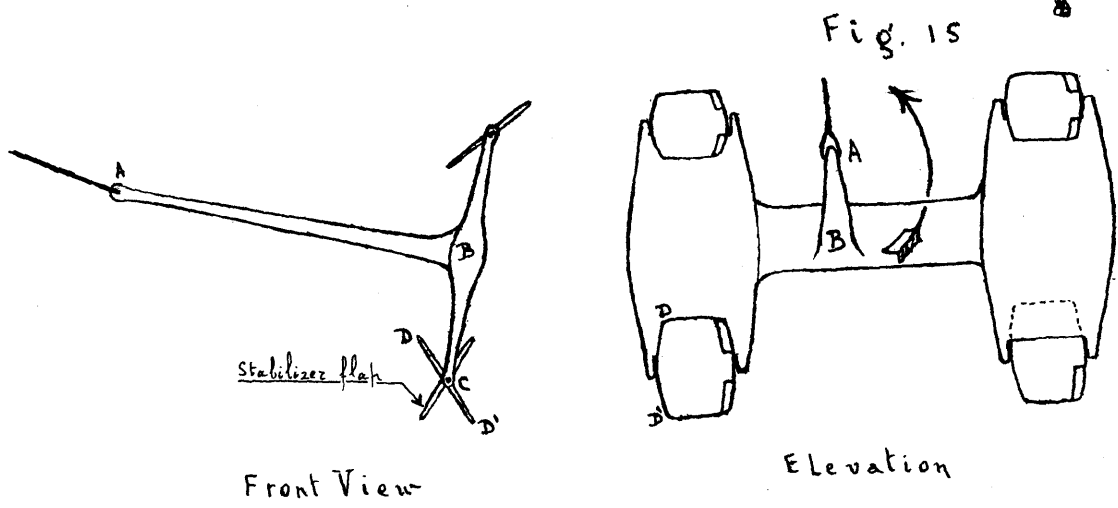
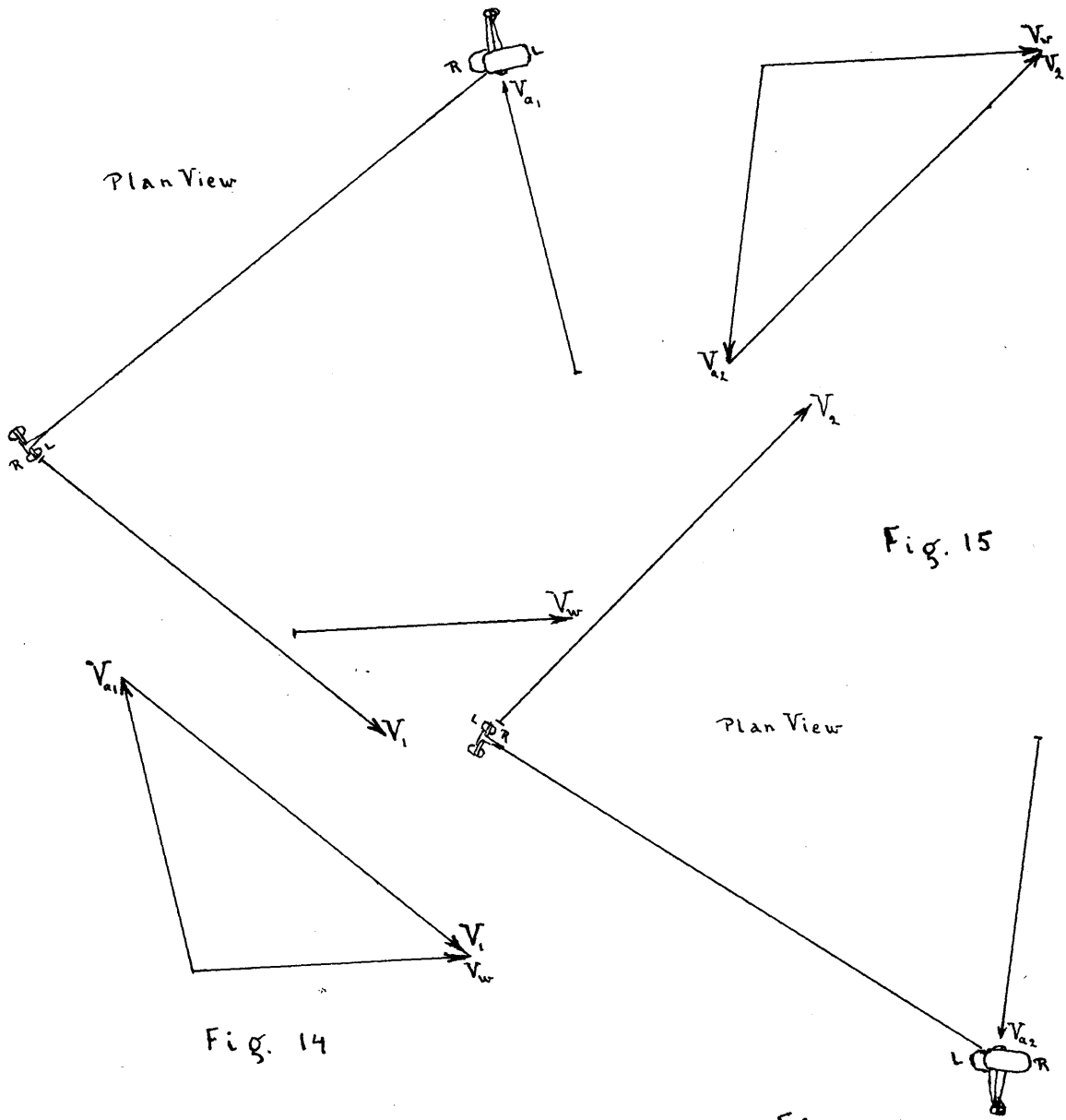

Fig. 16

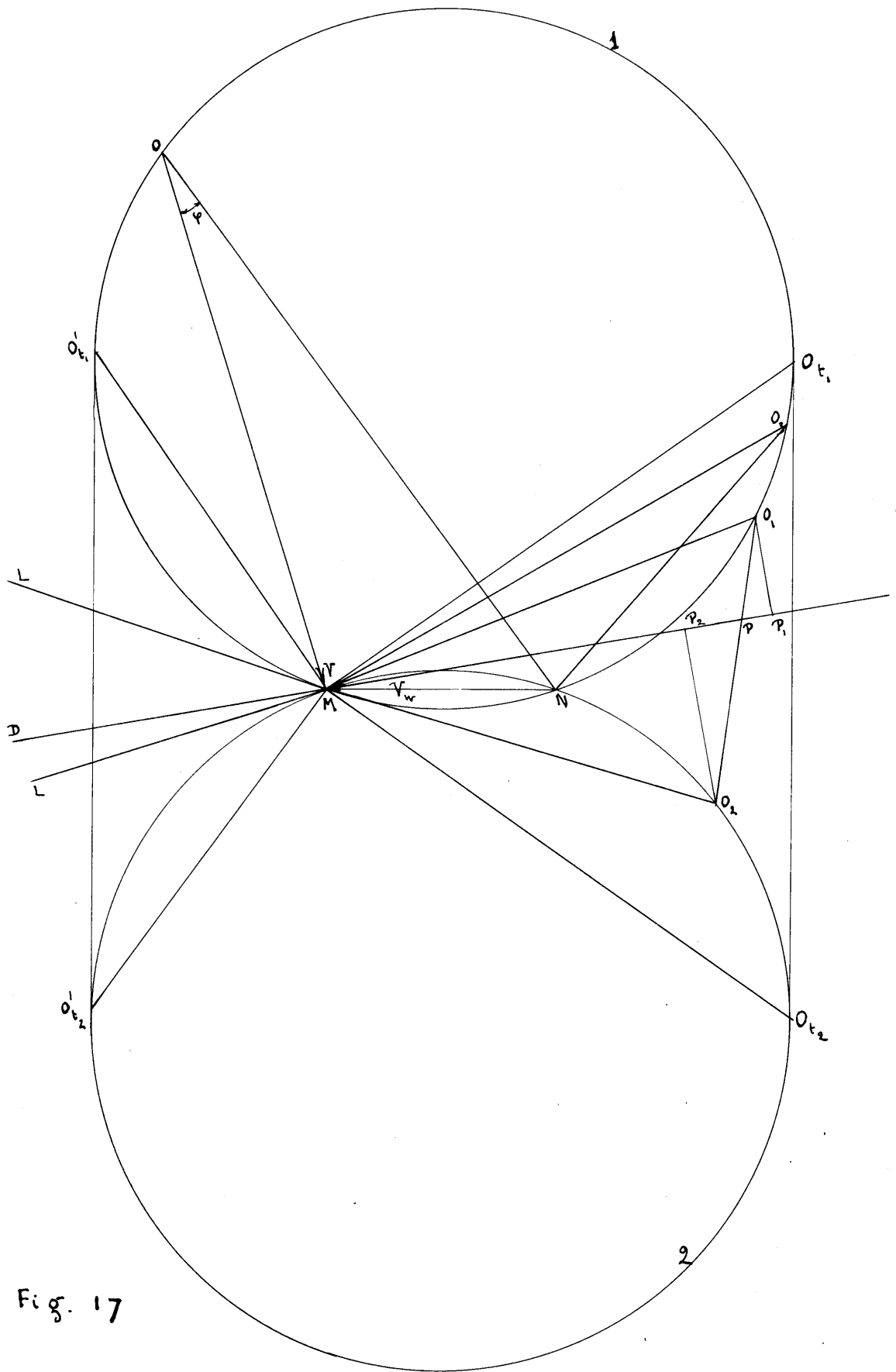

Fig. 17

Fig. 19

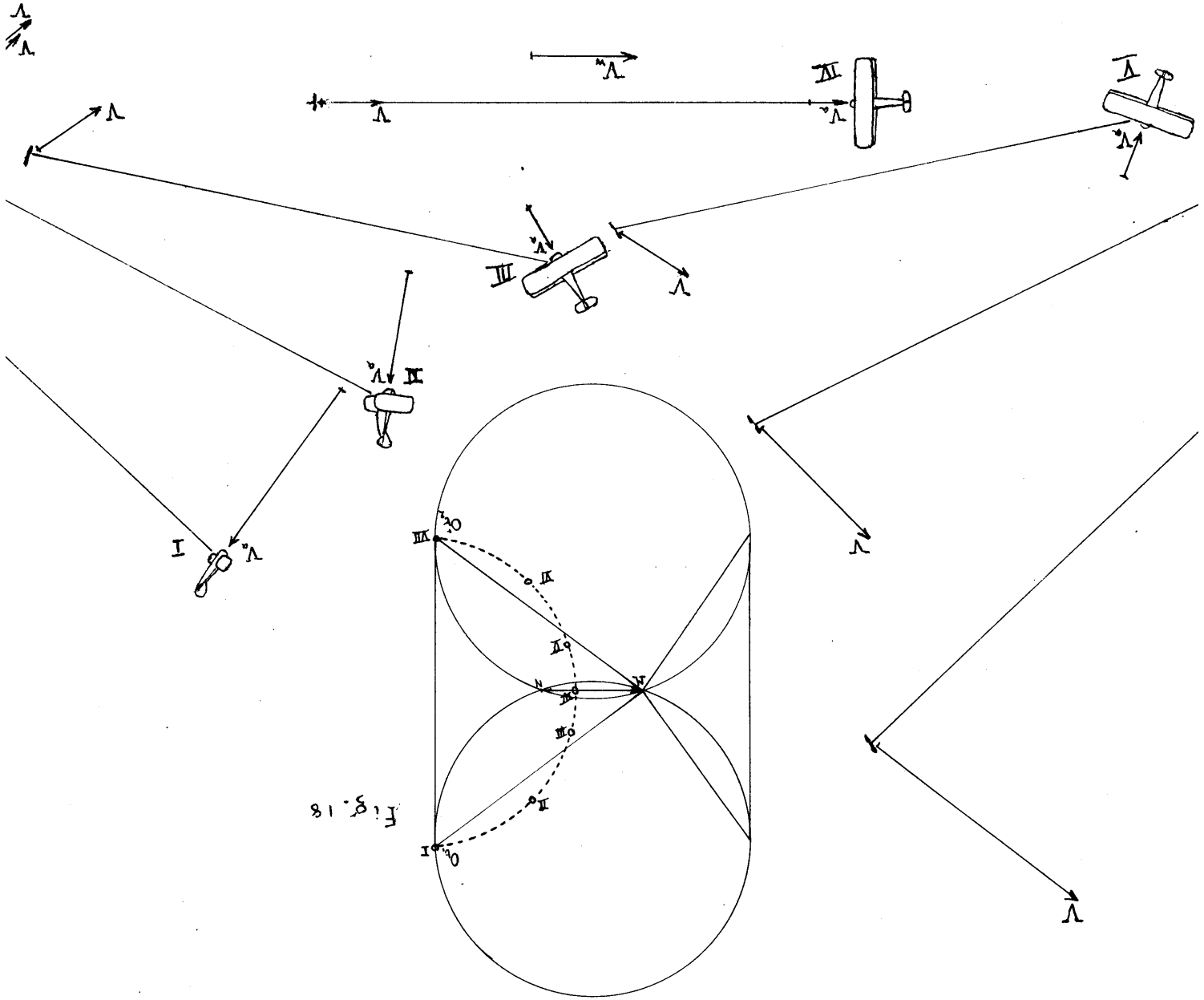

Fig. 18

Fig. 21

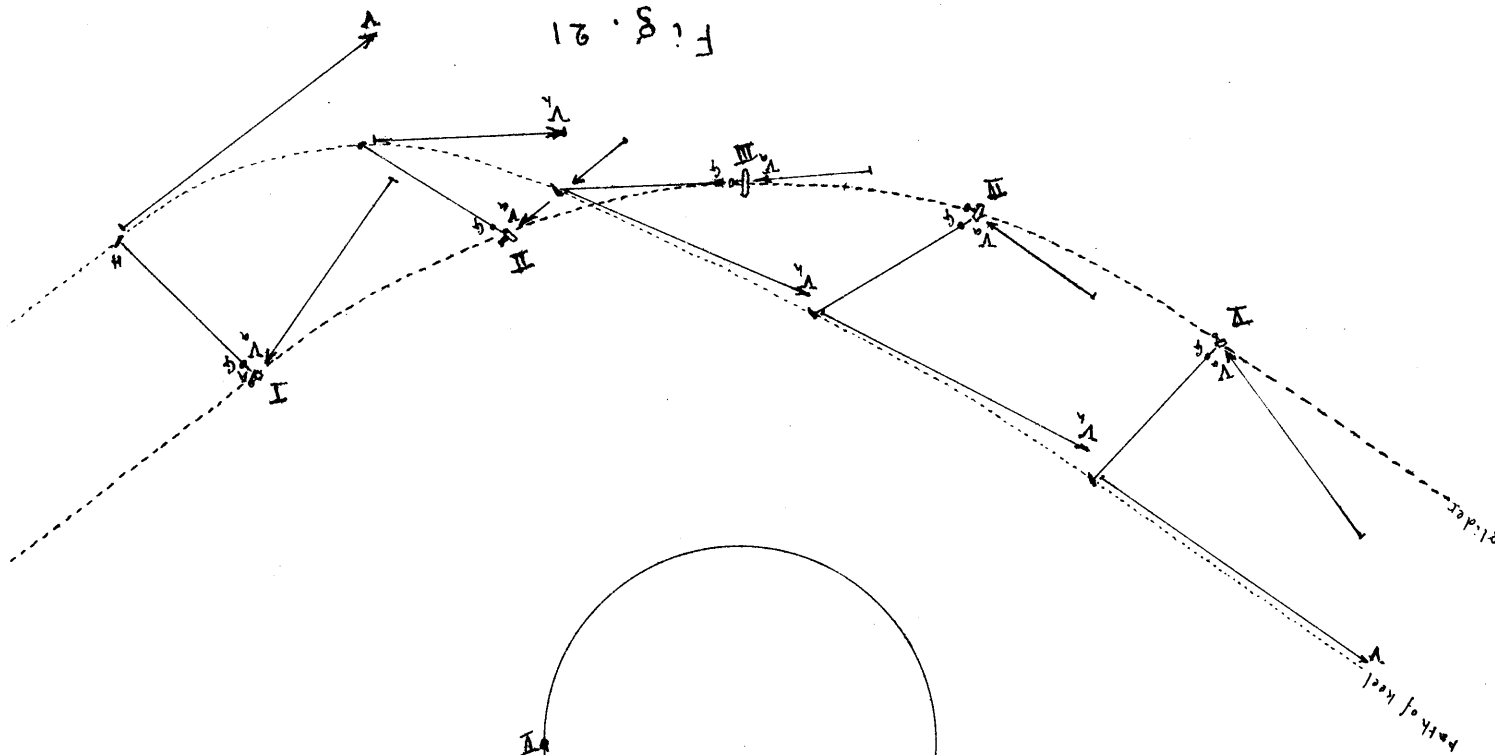
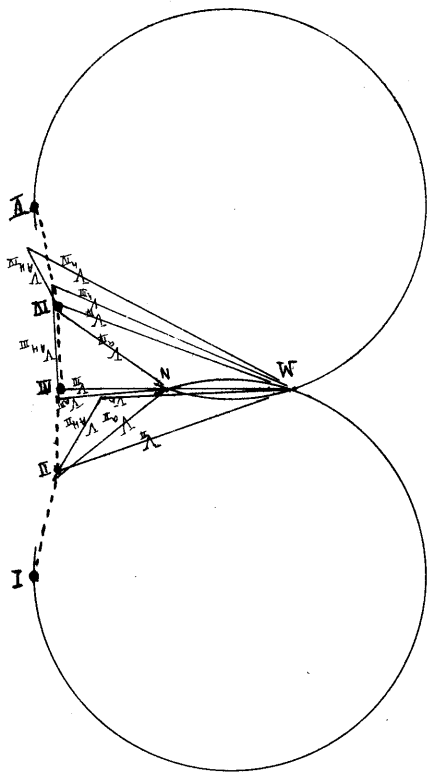
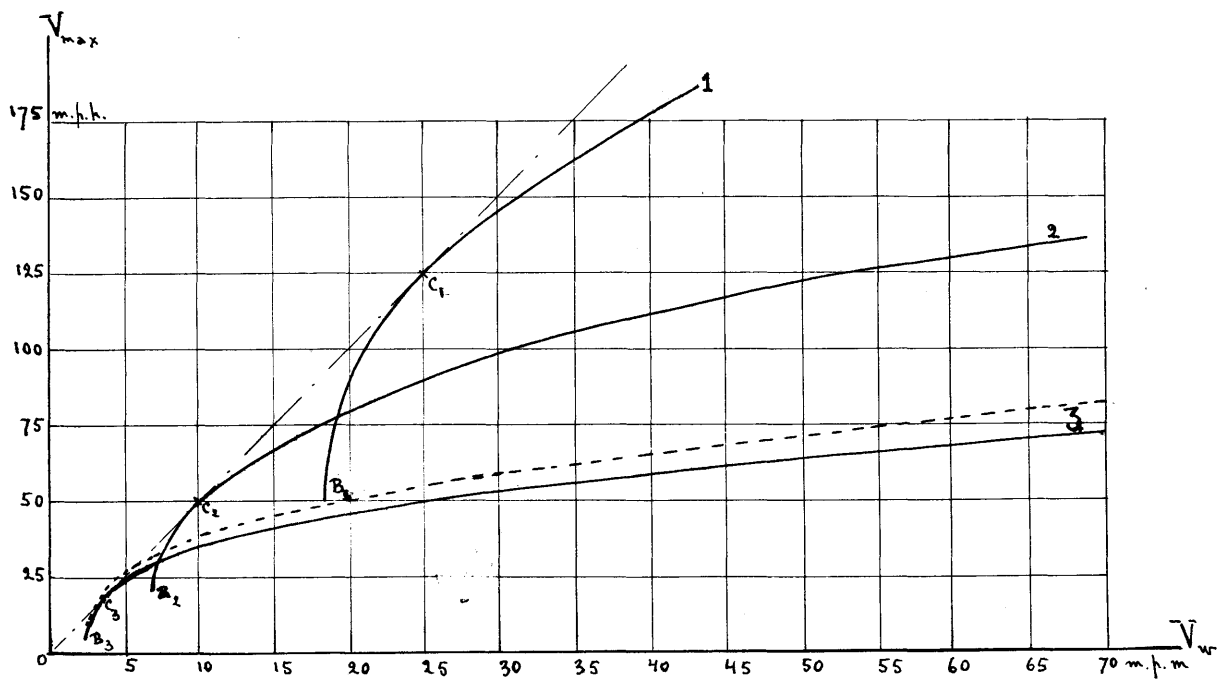
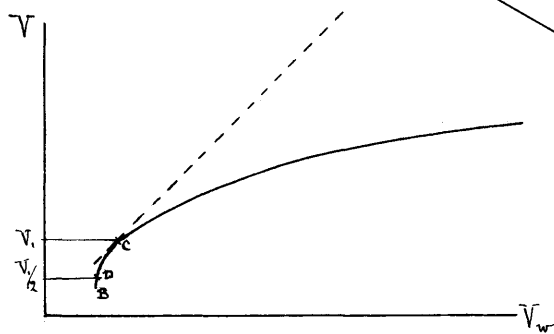
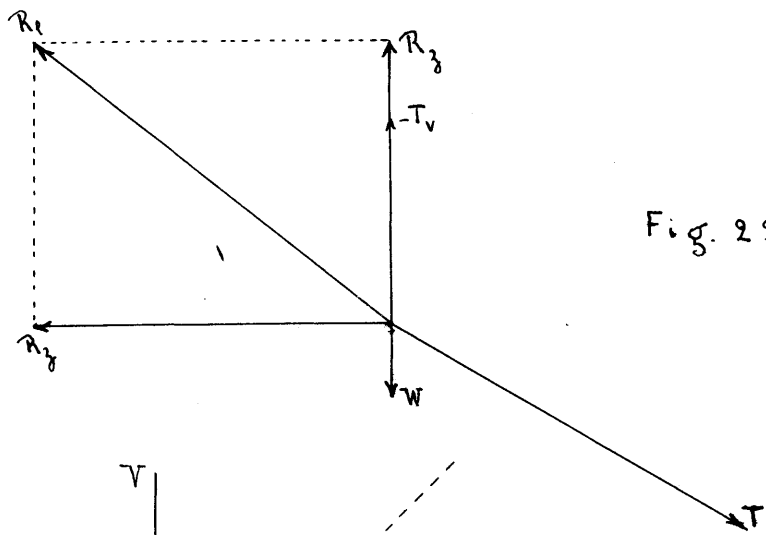

Fig. 20





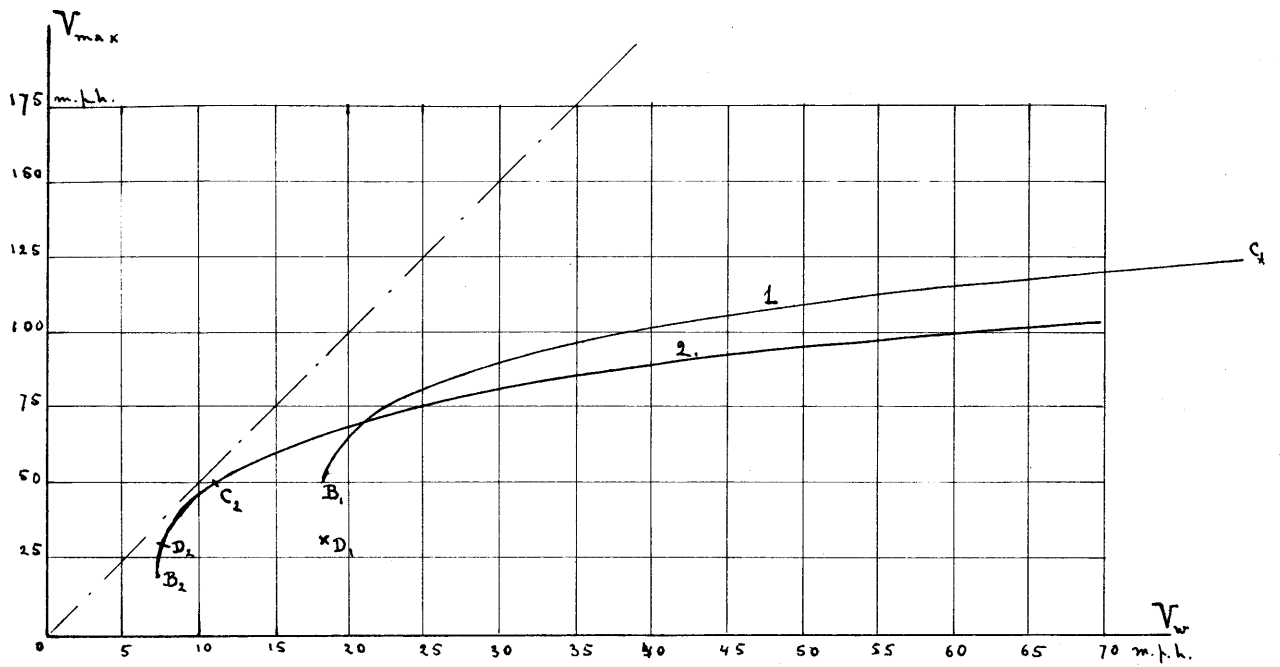

Fig. 25

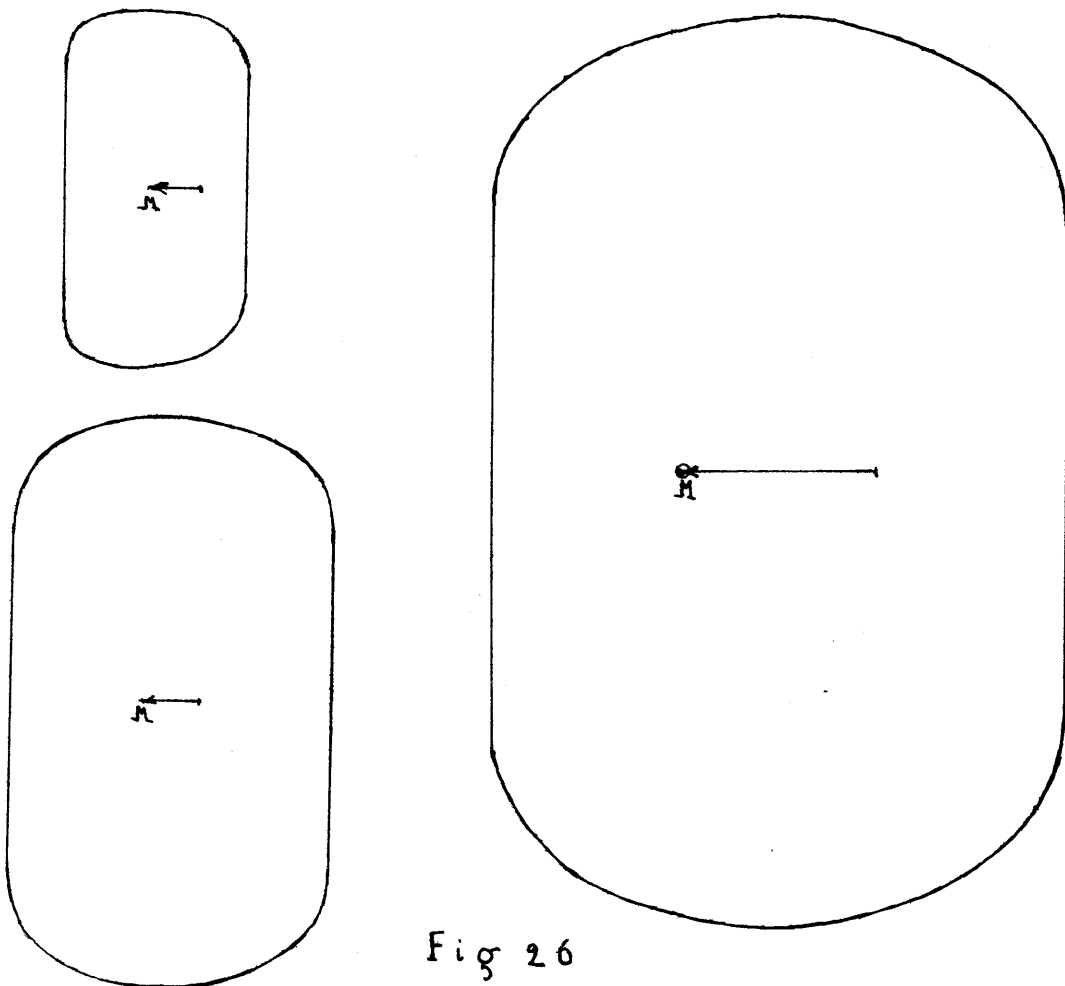

Fig 26