

MIT Open Access Articles

Experimental study of the interplay of channel and network coding in low power sensor applications

The MIT Faculty has made this article openly available. **Please share** how this access benefits you. Your story matters.

Citation: Angelopoulos, Georgios, Arun Paidimarri, Anantha P. Chandrakasan, and Muriel Medard. "Experimental Study of the Interplay of Channel and Network Coding in Low Power Sensor Applications." 2013 IEEE International Conference on Communications (ICC) (n.d.).

As Published: <http://dx.doi.org/10.1109/ICC.2013.6655396>

Publisher: Institute of Electrical and Electronics Engineers (IEEE)

Persistent URL: <http://hdl.handle.net/1721.1/86046>

Version: Author's final manuscript: final author's manuscript post peer review, without publisher's formatting or copy editing

Terms of use: Creative Commons Attribution-Noncommercial-Share Alike



Experimental Study of the Interplay of Channel and Network Coding in Low Power Sensor Applications

Georgios Angelopoulos, Arun Paidimarri, Anantha P. Chandrakasan and Muriel Médard
 Department of Electrical Engineering and Computer Science
 MIT, Cambridge, MA, USA

Abstract—In this paper, we evaluate the performance of random linear network coding (RLNC) in low data rate indoor sensor applications operating in the ISM frequency band. We also investigate the results of its synergy with forward error correction (FEC) codes at the PHY-layer in a joint channel-network coding (JCNC) scheme. RLNC is an emerging coding technique which can be used as a packet-level erasure code, usually implemented at the network layer, which increases data reliability against channel fading and severe interference, while FEC codes are mainly used for correction of random bit errors within a received packet. The hostile wireless environment that low power sensors usually operate in, with significant interference from nearby networks, motivates us to consider a joint coding scheme and examine the applicability of RLNC as an erasure code in such a coding structure. Our analysis and experiments are performed using a custom low power sensor node, which integrates on-chip a low-power 2.4 GHz transmitter and an accelerator implementing a multi-rate convolutional code and RLNC, in a typical office environment. According to measurement results, RLNC of code rate $4/8$ can provide an effective SNR improvement of about 3.4 dB, outperforming a PHY-layer FEC code of the same code rate, at a PER of 10^{-2} . In addition, RLNC performs very well when used in conjunction with a PHY-layer FEC code as a JCNC scheme, offering an overall coding gain of 5.6 dB.

I. INTRODUCTION

Continuous scaling of electronics as well as advances in wireless communications have enabled rapid development of several low power network architectures, with the most representative example being wireless sensor networks. Sensor nodes are typically powered by small batteries or energy harvesting sources, hence very strict constraints are associated with their energy consumption. Replacement cost of the battery (or the node) after the power source has been drained magnifies the problem. Since transmitting data is usually the dominant energy component of a wireless sensor node and implementing high complexity algorithms on its low power microcontroller is practically infeasible, it is of major importance to use highly efficient transmission schemes and communication algorithms in order to guarantee the required data reliability as well as to minimize energy consumption.

A widely used technique to combat errors introduced during data transmission is PHY-layer forward error correction (FEC) codes [1]. According to this technique, a packet of k information bits is mapped to a n -bit packet, resulting in an effective code rate of $r = k/n$ and a lower packet error rate. Designing efficient FEC codes for wireless sensor networks has been extensively studied in [2], [3], [4].

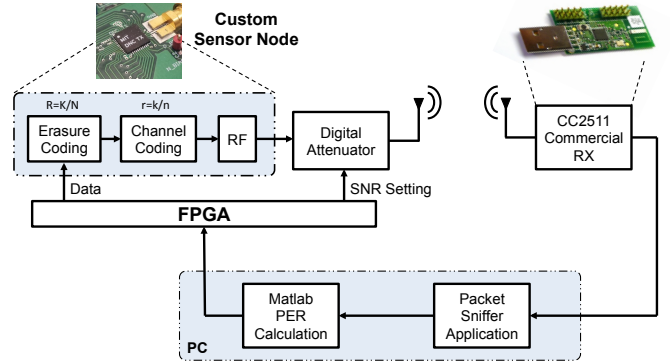

Fig. 1. Simplified block diagram of our experimental setup. A custom sensor node, integrating a 2.4 GHz transmitter and a joint channel-network coding engine, transmits data to a commercial receiver dongle, connected with a PC for decoding and statistics collection.

Apart from FEC codes, communication reliability can be further improved by the use of erasure codes [5]. Classical erasure schemes, which were initially introduced for the binary erasure channel, can be applied for packet-based correction techniques as well. According to this coding approach, cross-packet redundancy is introduced; for instance, K packets are encoded into N coded packets, resulting in an effective transmission rate of $R = K/N$. For optimal erasure codes, as long as any set of K out of the N packets is received, the initial information can be recovered. Random linear network coding (RLNC) [6] is such a coding technique, usually implemented at the network layer.

Since both coding techniques intend to improve data reliability, a question arises as to which combination of these two strategies is optimal from an error recovery and energy efficiency perspective. More recently, cross-layer coding schemes have attracted considerable attention, distributing the error correction process between the physical and network layer. Several works have considered the modeling and optimization of this approach, minimizing delay [7], outage probability [8] or maximizing effective throughput (goodput) [9]. It has been shown that the optimal combination of redundancy between the two layers depends mainly on channel characteristics and the average SNR regime of operation [10], [11].

In this work, the applicability and error correction performance of RLNC in typical indoor sensor applications operat-

ing in the ISM frequency band is examined. We investigate its coding gain benefits, when used with and without FEC codes, based on experiments in a typical office environment. Our measurements are performed using a custom low power sensor node, which integrates a low power 2.4 GHz transmitter and an accelerator for both PHY-layer FEC and RLNC. Fig. 1 shows our experimental setup; our custom wireless sensor node, whose block diagram is shown, transmits information to a commercial receiver dongle connected to a computer for extra processing and statistics collection. Our results indicate that RLNC provides a significant SNR improvement even without PHY-layer FEC. For instance, a RLNC code of rate 4/8 offers a coding gain of 3.4 dB, outperforming a convolutional code of the same code rate, at a PER of 10^{-2} .

In addition, according to our measurement results, RLNC performs very well against severe interference from nearby networks, which often causes transmitted packets to be erased and makes the wireless medium to behave like a block fading channel. However, in low SNR regimes, random bit errors overwhelm the packet-level RLNC correction process and make necessary the use of PHY-layer FEC. For this reason, a joint channel-network coding (JCNC) scheme is also considered in this work, which offers an overall coding gain of 5.6 dB, which is significantly more than can be obtained through RLNC or PHY-layer FEC only.

The rest of the paper is organized as follows. In Section II, a brief overview of packet-level erasure codes is provided and RLNC is analyzed. In Section III, our experimental setup is presented. The performance of the PHY-layer FEC, RLNC and JCNC based on our packet error rate measurements is discussed in Section IV. Section V concludes the paper.

II. PACKET-LEVEL ERASURE CODING

Considering a wireless link as a pure erasure channel on the packet-level emulates a channel model in which packets can be either delivered entirely correct or get completely erased due to several phenomena, such as severe interference or buffer queues overflows. For this type of channel, packet-level erasure codes can be successfully used to drive the outage probability to zero. Even if the erasure probability of the channel (p_e) is unknown, rateless erasure codes can be designed to adjust their rate automatically, encoding K initial packets up to a potentially infinite number of coded packets.

A. Rateless Erasure Codes

Some of the recently proposed rateless erasure codes, LT [12] and Raptor [13], have become very popular for transmission of large files over wired or high speed wireless networks. However, their applicability to low power sensor networks is questionable because of some of their characteristics. In general, these codes can recover the K initial packets after receiving $(1 + \epsilon)K$ encoded packets, where ϵ is an overhead which increases as K decreases; for instance, $\epsilon \approx 0.038$ for $K = 65536$, according to [13]. Because buffering and encoding several packets together introduces delay, a typical sensor application's constraints imply a much smaller value. However,

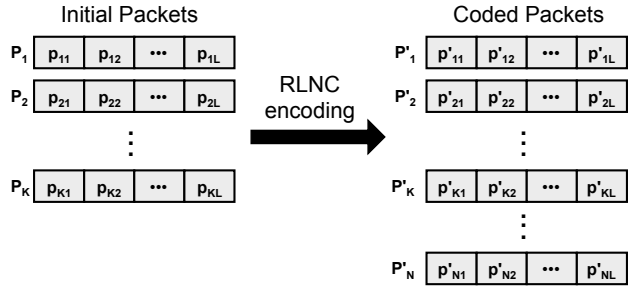

Fig. 2. Encoding process of RLNC. K initial packets are mapped to N coded packets of the same length. Each of the coded packets is a linear combination of the initial packets, weighted according to a set of randomly selected coefficients.

small values of K would result in large overhead which could significantly reduce the sensors' expected lifetime.

B. Brief Overview of Random Linear Network Coding

In this work, we examine the use of random linear network coding (RLNC) as a packet-level erasure code. Network Coding (NC), introduced in the seminal paper [14], is a cross-packet rateless coding method. Its main idea is to allow intermediate nodes of a network to code packets together and let the final destinations decode the mixtures [15]. The mixing of packets can be performed by several techniques; according to RLNC [6], encoded packets are produced as linear combinations of the initial packets, weighted according to randomly selected coefficients. In more details, assume that K packets (P_1, P_2, \dots, P_K) have to be transmitted, each of them containing L bytes¹ of data ($P_l = \{p_{1l}, p_{2l}, \dots, p_{Kl}\}$), as shown in Fig. 2. K is usually called the generation size of a coded block. The encoding process creates N coded packets (P'_1, P'_2, \dots, P'_N), where $N \geq K$, according to the equation:

$$p'_{il} = \sum_{j=1}^K p_{jl} \times c_{ij}, \quad (1)$$

where $1 \leq l \leq L$, $1 \leq i \leq N$ and c_{ij} are randomly selected coefficients, appended in headers of transmitted packets. Using matrix notation, the encoding process is described as:

$$P' = C \times P, \quad (2)$$

where P is the matrix of initial packets, C the matrix composed of the sets of coefficients and P' the matrix of coded packets. At the destination, receiving any K out of the N transmitted packets is enough to recover the initial packets since they corresponds to linearly independent coded combinations with very high probability. Thus, the overhead for RLNC is zero ($\epsilon = 0$) over large finite fields. The decoding process consists of the inverse process; inverting the coefficients matrix (C) and multiplying it by the matrix of coded packets (P').

¹In this case, the finite field $GF(2^8)$ is used. In general, a packet can be segmented into symbols of q bits each, making use of $GF(2^q)$.

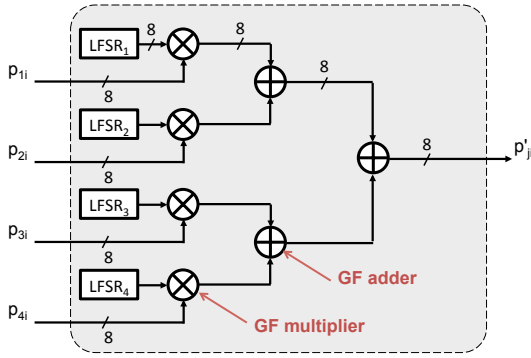

Fig. 3. Block Diagram of the RLNC encoder with $K = 4$. Multiplications and additions are performed over finite fields of size 8. Linear feedback shift registers (LFSRs) are used to produce the random coefficients.

C. Generation Size and Implementation Considerations

The probability of successfully decoding a packet in RLNC equals the probability of receiving at least K coded packets, because otherwise the block of coded packets can not be decoded. Thus, assuming p_e is the erasure probability, the packet error rate can be calculated as:

$$PER_{RLNC} = 1 - \sum_{i=K}^N \binom{N}{i} p_e^{N-i} (1 - p_e)^i \quad (3)$$

According to Eq. (3), for given p_e and code rate, PER_{RLNC} reduces exponentially with increasing K . However, delay constraints and memory requirements of low-power sensors dictate that K cannot be made large. Larger memories on the sensors increase power consumption as well as the cost of the system. For the design of our custom implementation of an RLNC accelerator, K of value 4 is chosen. It will be shown in the next Section that even with such a small value of K , good code performance is achieved.

In [16], authors study the custom implementation and energy analysis of RLNC in sensor nodes, and the energy per bit for the encoding process is calculated to be only a small fraction of the actual transmission energy per bit. In addition, since RLNC has been shown to provide energy benefits to sensor networks in several other ways, such as minimizing the number of acknowledgments to be received by a node [17] and simplifying security schemes [18], it is selected as a packet-level erasure code. A simplistic block diagram of the RLNC encoder, implementing Eq. (1), is shown in Fig. 3. All operations are performed over finite fields or Galois Fields (GF_s). This property guarantees that the result of any operation has the same length as the initial operands; thus the coded packets will have the same length as the initial ones.

III. EXPERIMENTAL SETUP

The experimental evaluation and performance comparison of PHY-layer FEC, RLNC and JCNC is done through careful and controlled experiments. The setup is shown in Fig. 1. A custom ultra-low power sensor integrates a 2.4 GHz transmitter, presented in [19], and an accelerator capable of

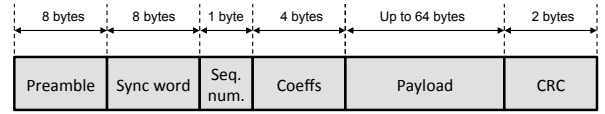

Fig. 4. The packet format used in our experiments.

convolutional encoding at rates 3/4, 1/2 and 1/3, and RLNC with $K = 4$. The sensor node is controlled by a Matlab program on a PC through an FPGA. A generic commercial transceiver (Texas Instruments CC2511 [20]) is used to receive the data from the transmitter. A transmission data rate of 500 kbps is used for all our measurements, which is limited by the maximum supported data rate of the CC2511 receiver. FSK modulation is employed for data transmission and coherent demodulation is performed at the receiver; hard Viterbi decoding and an interleaver of 4 bytes length are also used. The packet format is shown in Fig. 4. A PC-based packet sniffer software transfers the data from the CC2511 over a USB interface. This software then sends the received data over to the Matlab program which then computes the packet error rate.

The CC2511 chip provides the Received Signal Strength Indicator (RSSI), which is a good proxy for the SNR on the channel. In the rest of the paper, RSSI and SNR values will be treated interchangeably. In order to perform detailed PER measurements and estimate coding gains, the SNR of the received signal needs to be changed. The intrinsic output power tuning on the transmitter is limited (about 7 dB), and it is not possible to physically move the devices apart in a repeatably accurate manner. To overcome this issue, a digitally controlled RF attenuator is connected between the transmitter IC and the antenna. A 31 dB dynamic range, with 1 dB/step [21] provides a very repeatable method of sweeping the SNR of the channel. For each setting of the attenuator and code rate, 10^3 packets are transmitted, each of 48 bytes length.

IV. MEASUREMENTS AND RESULTS

In this Section, the performance of the PHY-layer FEC, RLNC and JCNC schemes based on our measurement in a typical indoor environment is presented and discussed.

A. Performance of PHY-layer FEC and RLNC Operating Separately

The error correction performance of the PHY-layer FEC code is shown in Fig. 5. The measured PERs for different code rates are plotted. A PHY-layer FEC of code rate 3/4 provides only a marginal improvement over uncoded data transmission, while FEC of code rate 1/2 provides approximately 2.25 dB SNR improvement. Use of a PHY-layer FEC code with rate 1/3 offers only a small additional coding gain compared to the rate 1/2 code; as expected, increasing the redundancy of the FEC code provides diminishing returns in the coding gain.

Fig. 6 shows the performance of RLNC for several code rates, when no PHY-layer FEC code is used. At a PER of 10^{-2} , its effective SNR improvement is 2.5 dB and 3.4 dB for the 4/6 and 4/8 code rate, respectively. The PER curve of

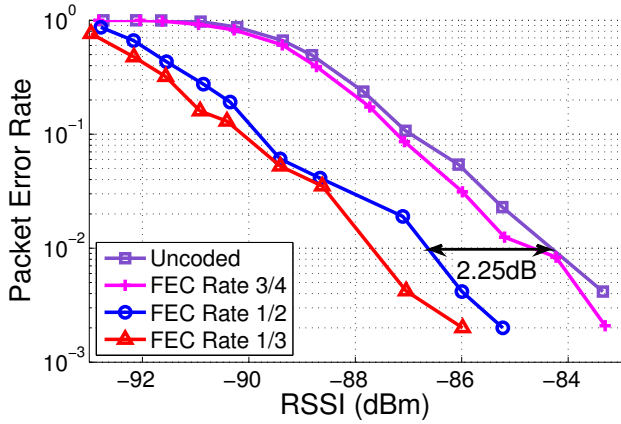

Fig. 5. Measured packet error rate (PER) curves for a convolutional (FEC) code of rate = 3/4, 1/2 and 1/3 compared with uncoded packets' transmission.

the PHY-layer FEC of rate 1/2 is also plotted in the same figure with dashed line. Comparing the PER curves of the two coding schemes in Figs. 5 and 6, a very important characteristic about their behavior becomes evident. Although the same amount of total information is transmitted for both PHY-layer FEC and RLNC of code rate 1/2, in the low RSSI regime, PHY-layer FEC code performs better than RLNC but, for higher RSSI values, the roles are reversed. For instance, at PER of 10^{-2} , RLNC offers an additional coding gain of 1.1 dB. This happens because the slope of the PER curves for RLNC is much steeper compared to the PHY-layer FEC curves.

B. Discussion on the performance of PHY-layer FEC and RLNC

The difference in the PER curves for the two coding schemes can also be explained by examining the behavior of the wireless channel in typical indoor environments. For a AWGN channel with fixed and known SNR, PHY-layer FEC codes can be designed to communicate packets reliably, as long as their transmission rate is below the capacity of the channel. In that case, packet-level erasure codes are not necessary. On the other hand, for an erasure channel, in which packets are either received entirely correct or completely erased, a packet-level erasure code (such as RLNC) can be sufficient to provide the necessary reliability, making a physical layer code unnecessary. In practice, a realistic wireless indoors channel lays somewhere between these two extreme limits. Although noise is always present in the wireless medium causing random bit errors within a packet, its effects are more pronounced in the low SNR regime and these random errors are better corrected by a PHY-layer FEC code. However, for higher SNR values, interference from nearby networks operating at the same frequency band becomes the dominant limiting factor, creating packet collisions with large burst errors and making the channel behave like a block fading channel. In that case, RLNC performs better by introducing a longer dependency across packets, which can be translated to diversity gains.

In our indoor experiments, interference from nearby networks is a significant source of errors. This can be mainly

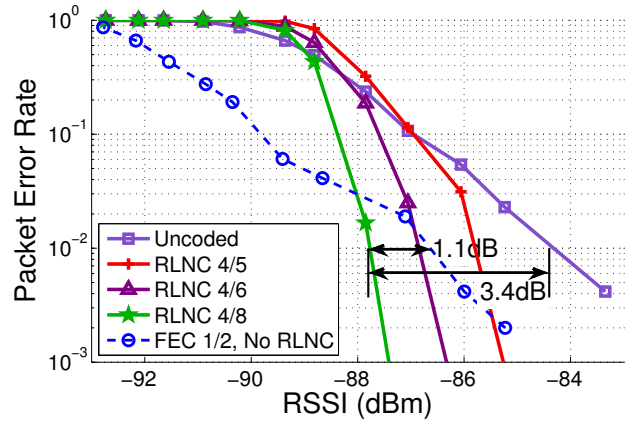

Fig. 6. Measured packet error rate (PER) curves for random linear network coding (RLNC) of rate = 4/5, 4/6 and 4/8 compared with uncoded packets.

explained by two reasons. Firstly, transmission time of a typical size 802.11g packet ranges from 0.32 msec to 2.8 msec depending on the used data rate, while a packet with payload of 48 bytes transmitted from our sensor has approximate duration of 0.8 msec. In addition to the comparable packets' duration, the custom sensor used in our experiment is designed for ultra-low power sensor applications, such as for body area networks, and, due to power constraints, does not perform carrier sense before every packet transmission. Although incorporation of medium sensing would reduce the number of collided packets by backing-off the sensor when the medium is busy, it wouldn't eliminate the problem because of the the difference in the transmission range of devices communicating in the highly populated ISM band. Low power signals (around -10 dBm) transmitted from sensors might not be detectable from nearby access points and other mobile devices. However, packets transmitted at a much higher output power (around +15 dBm in 802.11g networks) from these devices often result in collisions with sensor packets that are on-the-air at that time. This complicated behavior of the wireless medium motivates the use of a combination of the two coding schemes which leads to significantly better performance.

C. Performance of JCNC

The performance of the joint channel-network coding (JCNC) scheme is shown in Fig. 7. According to our measurement results, JCNC of effective rate 1/3 performs better than the PHY-layer FEC code of the same rate by approximately 1 dB at PER of 10^{-2} . However, at the very low SNR regime, the PHY-layer FEC code has the best performance because, as explained earlier, use of RLNC requires successful reception of at least K packets for a block to be decoded. This graph confirms the harmonic synergy between PHY-layer FEC codes and RLNC in a joint coding scheme. As is shown, the coding gain of joint PHY-layer FEC and RLNC is 5.6 dB for an effective code rate 1/4. Table I summarizes the effective SNR improvements for different PHY-layer FEC and RLNC code rates at two target PERs.

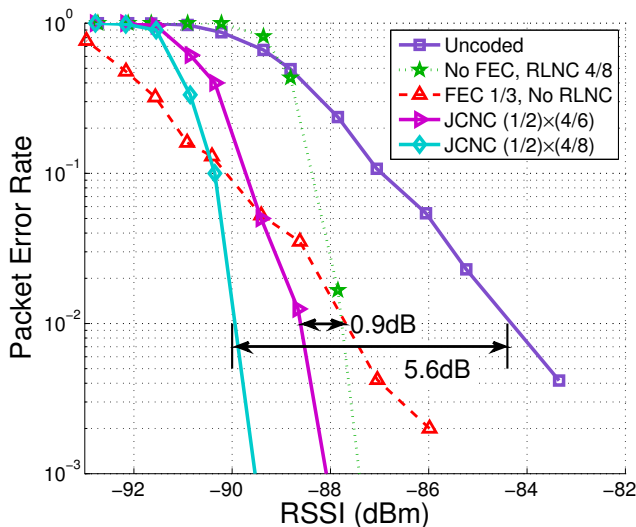

Fig. 7. Measured packet error rate (PER) curves for the joint channel-network coding (JCNC) scheme.

TABLE I
EFFECTIVE SNR IMPROVEMENT FOR THE JCNC SCHEME.

FEC Rate	RLNC Rate	SNR improvement	
		PER= 10^{-1}	PER= 10^{-2}
1	1	-	-
1	4/5	0dB	1.5dB
1	4/6	0.625dB	2.5dB
1	4/8	1.5dB	3.4dB
1/2	1	2.5dB	2.25dB
1/2	4/5	2.25dB	4dB
1/2	4/6	2.75dB	4.25dB
1/2	4/8	3.5dB	5.6dB

V. CONCLUSION

Modern low power indoor sensor networks have to communicate their information under strict resource constraints, usually operating in the overpopulated ISM frequency band. In this work, we study the use of random linear network coding (RLNC) in sensor applications as an erasure code for improved data reliability. RLNC introduces redundancy across several packets and can offer a significant advantage to sensor networks operating in severe interference environments. However, in the low SNR regime, random bit errors overwhelm this packet-level erasure code and the use of a PHY-layer FEC becomes important. For this reason, we also study a joint channel-network coding (JCNC) scheme, examining the synergy between a convolutional code and RLNC. We perform measurements in a typical office environment using a custom sensor node, integrating on-chip a low power 2.4 GHz transmitter and an accelerator implementing both PHY-layer FEC and RLNC. The results show that RLNC provides an effective coding gain of 3.4 dB, outperforming the PHY-layer FEC code of the same code rate, at a PER of 10^{-2} . In addition, it performs well when used in conjunction with the PHY-layer code as a JCNC scheme, offering an overall coding gain of 5.6 dB.

ACKNOWLEDGMENT

The authors would like to thank P. Nadeau and X. Shi for discussions. Funding was provided by the Interconnect Focus Center, one of six research centers funded under the FCRP, an SRC entity. Chip fabrication was done through the TSMC University Shuttle Program and the low power resonators used in the transmitter were provided by Avago Technologies.

REFERENCES

- [1] S. Lin and D. J. Costello, *Error Control Coding: Fundamentals and Applications*, 2nd ed. Prentice Hall: Englewood Cliffs, NJ, 2004.
- [2] S. L. Howard, C. Schlegel, and K. Iniewski, "Error control coding in low-power wireless sensor networks: when is ECC energy-efficient?" *EURASIP J. Wirel. Commun. Netw.*, vol. 2006, no. 2, p. 29, Apr. 2006.
- [3] M. Vuran and I. Akyildiz, "Error control in wireless sensor networks: A cross layer analysis," *Networking, IEEE/ACM Transactions on*, vol. 17, no. 4, pp. 1186–1199, Aug. 2009.
- [4] Z. Kashani and M. Shiva, "Power optimised channel coding in wireless sensor networks using low-density parity-check codes," *Communications, IET*, vol. 1, no. 6, pp. 1256–1262, Dec. 2007.
- [5] M. Luby, M. Mitzenmacher, M. Shokrollahi, and D. Spielman, "Efficient erasure correcting codes," *Information Theory, IEEE Transactions on*, vol. 47, no. 2, pp. 569–584, Feb. 2001.
- [6] T. Ho, M. Médard, R. Koetter, D. Karger, M. Effros, J. Shi, and B. Leong, "A random linear network coding approach to multicast," *Information Theory, IEEE Transactions on*, vol. 52, no. 10, pp. 4413–4430, Oct. 2006.
- [7] M. Vehkaperä and M. Médard, "A throughput-delay trade-off in packetized systems with erasures," in *Information Theory, 2005. ISIT 2005. Proceedings. International Symposium on*, Sept. 2005, pp. 1858–1862.
- [8] C. Berger, et al., "Optimizing joint erasure- and error-correction coding for wireless packet transmissions," *Wireless Communications, IEEE Transactions on*, vol. 7, no. 11, pp. 4586–4595, Nov. 2008.
- [9] P. Wu and N. Jindal, "Coding versus arg in fading channels: How reliable should the phy be?" *Communications, IEEE Transactions on*, vol. 59, no. 12, pp. 3363–3374, Dec. 2011.
- [10] T. Courtade and R. Wesel, "Optimal allocation of redundancy between packet-level erasure coding and physical-layer channel coding in fading channels," *Communications, IEEE Transactions on*, vol. 59, no. 8, pp. 2101–2109, Aug. 2011.
- [11] N. Fawaz and M. Médard, "A converse for the wideband relay channel with physically degraded broadcast," in *Information Theory Workshop (ITW), 2011 IEEE*, Oct. 2011, pp. 425–429.
- [12] M. Luby, "LT codes," in *Foundations of Computer Science, 2002. Proceedings. The 43rd Annual IEEE Symp. on*, 2002, pp. 271–280.
- [13] A. Shokrollahi, "Raptor codes," *Information Theory, IEEE Transactions on*, vol. 52, no. 6, pp. 2551–2567, June 2006.
- [14] R. Ahlswede, N. Cai, S.-Y. Li, and R. Yeung, "Network information flow," *Information Theory, IEEE Transactions on*, vol. 46, no. 4, pp. 1204–1216, July 2000.
- [15] C. Fragouli, J.-Y. Le Boudec, and J. Widmer, "Network coding: an instant primer," *SIGCOMM Comput. Commun. Rev.*, vol. 36, no. 1, pp. 63–68, Jan. 2006.
- [16] G. Angelopoulos, M. Médard, and A. P. Chandrakasan, "Energy-aware hardware implementation of network coding," in *Proceedings of the IFIP TC 6th international conference on Networking*, ser. NETWORKING'11. Berlin, Heidelberg: Springer-Verlag, 2011, pp. 137–144.
- [17] X. Shi, M. Médard, and D. E. Lucani, "When both transmitting and receiving energies matter: an application of network coding in wireless body area networks," in *Proceedings of the IFIP TC 6th international conference on Networking*, ser. NETWORKING'11, 2011, pp. 119–128.
- [18] J. Vilela, L. Lima, and J. Barros, "Lightweight security for network coding," in *Communications, 2008. ICC '08. IEEE International Conference on*, May 2008, pp. 1750–1754.
- [19] A. Paidimarri, P. Nadeau, P. Mercier, and A. Chandrakasan, "A 440pj/bit 1Mb/s 2.4GHz multi-channel FBAR-based TX and an integrated pulse-shaping PA," in *VLSI Circuits, 2012 Symp. on*, June 2012, pp. 34–35.
- [20] "CC2511 data sheet," Texas Instruments, Dallas, TX. [Online]. Available: <http://www.ti.com/lit/gpn/cc2511f32>
- [21] "ZX76-31-PP-S+ data sheet," Mini Circuits, Brooklyn, NY. [Online]. Available: <http://www.minicircuits.com/pdfs/ZX76-31-PP+.pdf>