

DEADZONE: INHABITING THE HYPOXIC SYSTEM

by
Kyle Altman

Bachelor's in Design, University of Florida, May 2011

Submitted to the Department of Architecture in Partial Fulfillment
of the Requirements for the Degree of Master of Architecture at the
Massachusetts Institute of Technology
February 2014

© 2014 Massachusetts Institute of Technology. All rights reserved.

The author hereby grants to MIT permission to reproduce and to distribute
publicly paper and electronic copies of this thesis document in whole or in
part in any medium now known or hereafter created.

Signature of Author:
Department of Architecture
January 16, 2014

Certified by :
Andrew Scott
Associate Professor of Architecture
Thesis Advisor

Accepted by:
Takehiko Nagakura
Chair of the Department Committee on Graduate Students

Thesis Readers

Antón García-Abril PhD
Professor of Architecture

Gediminas Urbonas MFA
Associate Professor of Art, Culture and Technology

DEADZONE: INHABITING THE HYPOXIC SYSTEM

By: Kyle Altman

Submitted to the Department of Architecture on January 16, 2014 in Partial Fulfillment of the requirements for the degree of MArch.

Hypoxia: a phenomenon that occurs in aquatic environments as dissolved oxygen is reduced in concentration to a point where it becomes detrimental to organisms living in the system.

Since the mid 20th century, oceanographers began noting increased instances of dead zones when heavy fertilization became a widespread practice in modern agricultural mass production. These systems typically occur near inhabited coastlines where aquatic life is most concentrated resulting in dwindling fish stocks and increased travel distances to access fertile water decreasing fuel efficiency across the global fishing industry, which consumes approximately 50 billion liters of fuel per year. In addition, recreational activities and tourism have been affected by the resulting odor and discoloration of low oxygen level zones.

The Northern Gulf of Mexico region has seen substantial growth in the average size and severity of its hypoxic zone and is one of the largest systems today. Where, 41% of the contiguous United States drains into the Mississippi basin releasing a tremendous amount of nitrogen and phosphorus into the coastal areas offering a nesting ground for massive algae blooms to occur.

Maritime institutes have been attempting to resolve this issue with larger infrastructural landscape interventions including: artificial wet lands, reefs, oyster beds, diminishing fertilizer use, etc. However, Completely diminishing dead zones, especially the systems that pose the most threat, would involve incredible global engineering and cultural shifts. This proposal is not attempting to completely resolve the issue of hypoxic systems. It accepts the inexhaustible supply of rich nutrients as a critical gesture of visibility catering to the affects of the social political agenda inland. Meaning, this reoccurring issue of hypoxia would be utilized as an opportunity to deploy a network of interventions offering a platform or tangible interface for maritime institutes to utilize as a catalyst to generate soft boundaries of oxygenated waters for animal life attraction, harvesting algae, as well as progressing data throughout the Louisiana-Texas shelf for the understanding of dead zones.

Thesis Supervisor: Andrew Scott

Title: Associate Professor of Architecture



DEADZONE



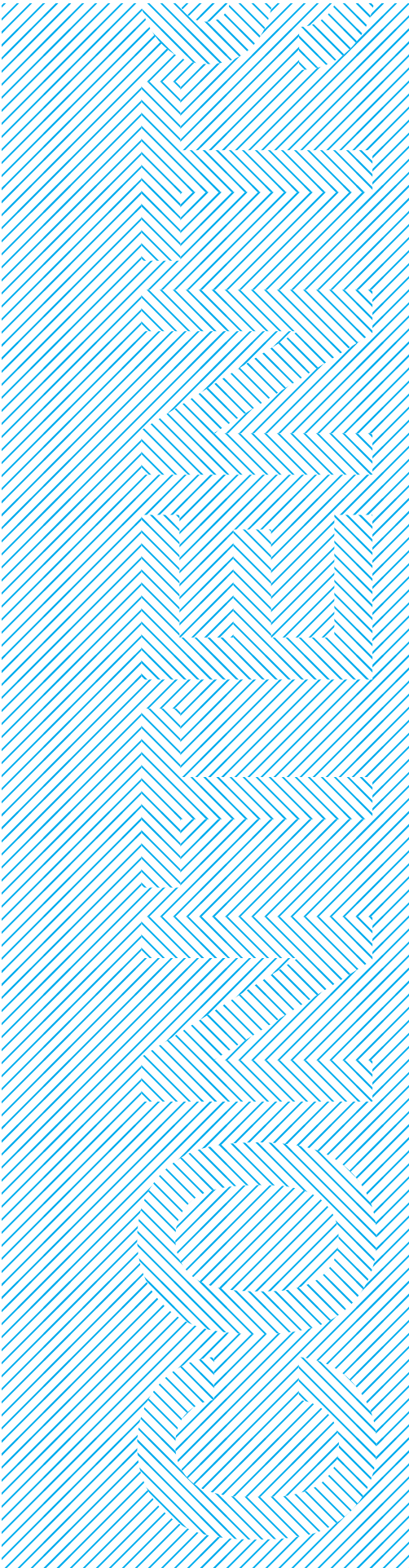

Contents

1. Abstract	02 - 03
2. Hypoxia	
Hypoxia	08 - 15
Dead Zone in the Gulf of Mexico	16 - 19
Algae Typologies	20 - 21
3. Precedents	
Early Studies	22 - 24
Platform Typologies	25 - 35
4. Proposal	
Hypoxia Severity Pinpoints	36 - 40
Techniques of Mitigation	40 - 41
Modalities into 2050	42 - 43
Satellite Research Station	44 - 57
5. Process	
Final Models	58 - 75
First Review	76 - 79
Midterm Review	80 - 87
Post Midterm	88 - 95
7. Final Dead Zone	96 - 107
8. Bibliography	108 - 109

Hypoxia

Eutrophication is a phenomenon in which pollution of aquatic ecosystems with excessive nutrients like nitrogen and phosphorus results in increased primary productivity by phototrophic bacteria, algae and higher aquatic plants. It is now recognized to be one of the most important factors contributing to habitat change and temporal expansion of harmful algal blooms. Sewage discharge and runoff from agriculture have been identified as the main sources of nutrient pollution. Both nitrogen and phosphorus have been implicated as contributing to eutrophication, but nitrogen has received more attention because the amount of nitrogen used in fertilizers is far greater than phosphorus. Elevated levels of nutrients can change the phytoplankton community composition through induced changes in predation, resource limitation, light availability and biological effects on sediments.

The primary eutrophic symptoms in surveys done by the NOAA were decreased light transparency, high chlorophyll a concentration, and change in algal dominance. The composition of phytoplankton depends on a balance of many factors, and phytoplankton ecology needs

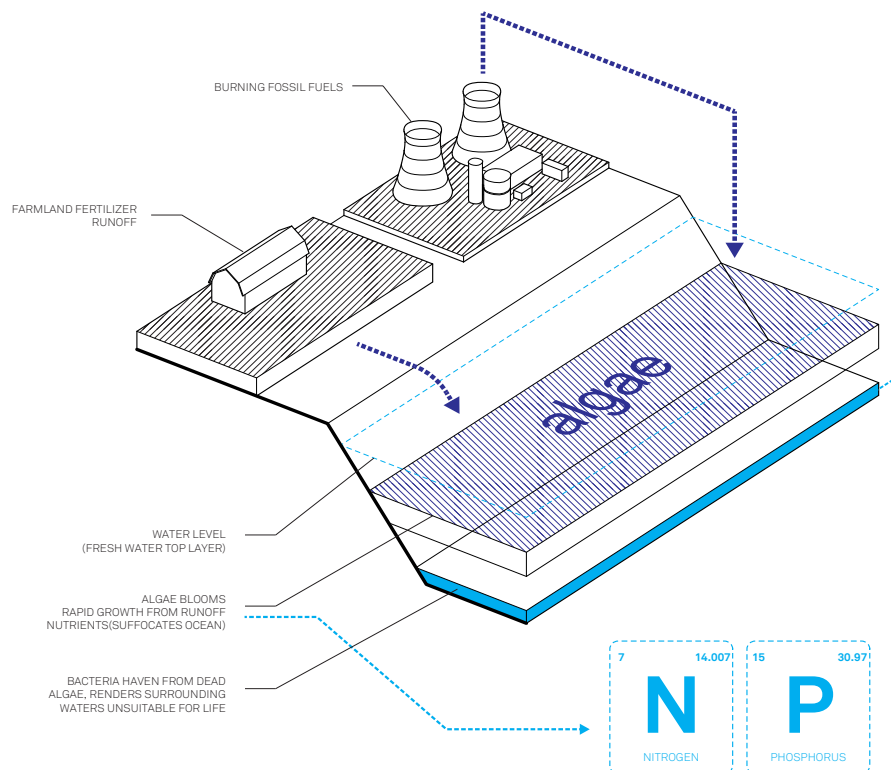



figure 1.1: Aerial view of an algae bloom in the Gulf of Mexico

to be viewed within the context of spatial heterogeneity and seasonal variations.

Effects and Locations

Hypoxia describes a condition of low dissolved oxygen content ($< 2\text{mg/L}$) in natural water bodies that is environmentally undesirable because it does not support most marine creatures and can result in large-scale kills of aquatic animals. Hypoxia typically occurs following a large-scale algae bloom that dies off and is subsequently consumed by heterotrophic bacteria, which deplete all the available

oxygen in the water column.

Major coastal hypoxic zones are known to occur in approximately 146 locations around the globe and can cover vast oceanic expanses, larger than $90,000\text{ km}^2$ in some cases.¹ Notable dead zones in the United States include the northern Gulf of Mexico region, surrounding the outfall of the Mississippi River, and the coastal regions of the Pacific Northwest, and the Elizabeth River in Virginia Beach, all of which have been shown to be recurring events over the last several years.² The image above is an aerial view revealing the beginning of the eutrophication process taking place in



one of the largest hypoxic systems today: The Gulf of Mexico. Shrimp trawlers first reported a 'dead zone' in the Gulf of Mexico in 1950 but it wasn't until 1970 when the size of the hypoxic zone had increased that scientists began to investigate. In the 1970s, marine dead zones were first noted in areas where intensive economic use stimulated "first-world" scientific scrutiny: in the U.S. East Coast's Chesapeake Bay, in Scandinavia's strait called the Kattegat, which is the mouth of the Baltic Sea and in other important Baltic Sea fishing grounds, in the Black Sea, and in the northern Adriatic. A 2008 study counted 405 dead zones worldwide³

Since the 1970s dead zones have increased in size significantly and maritime institutes are searching for options such as artificial wetlands, reefs, and deconstruction. New studies suggest collecting or harvesting the algae may begin to diminish the area of severity. Figures 1.2 and 1.3 represent this landscape infrastructure system through an axonometric.

-
1. *Chih-Ting Kuo, 2010*
 2. *The Economist, 2012*
 3. *David Perlman, 2008*

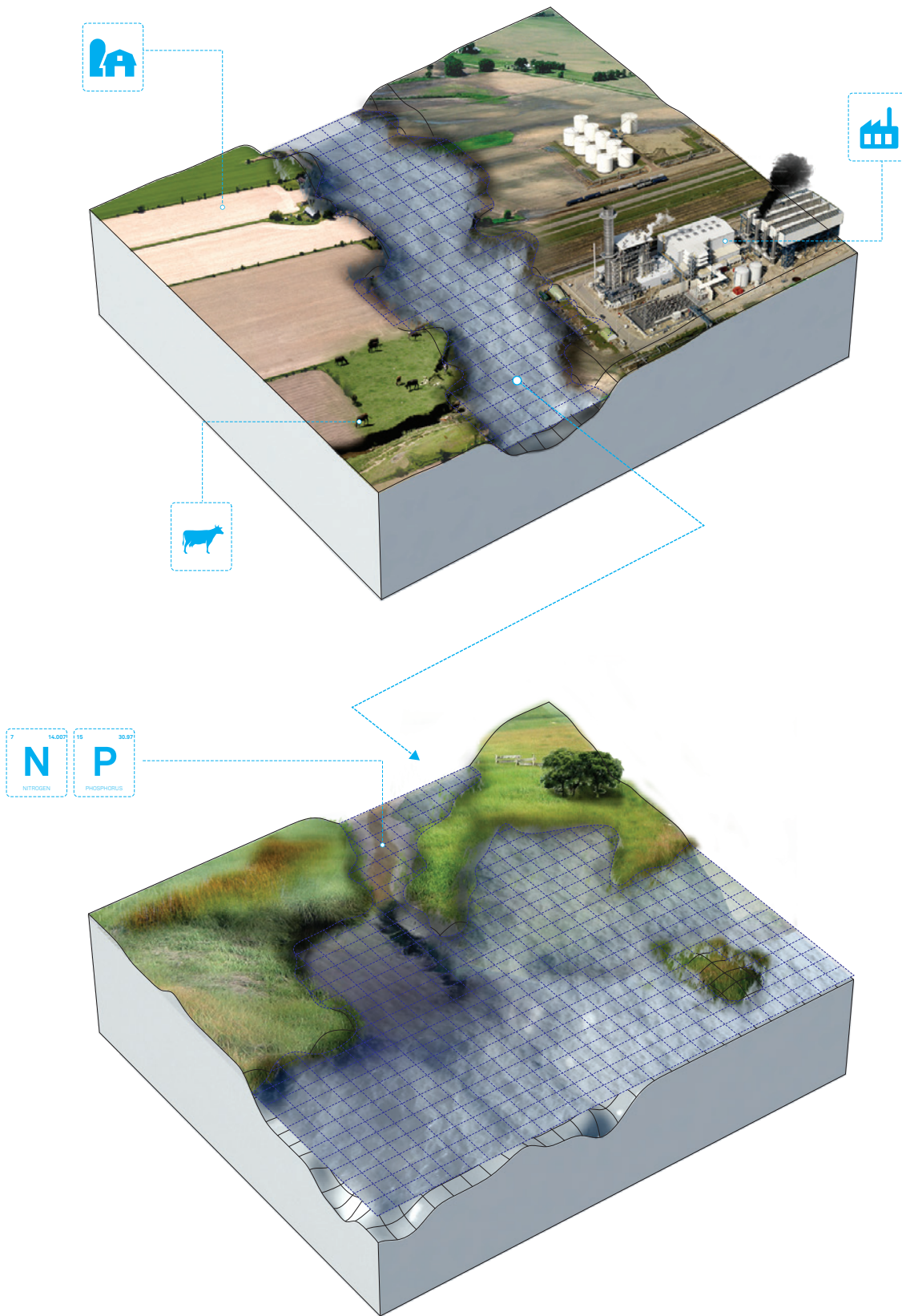

figure 1.2: Inland nutrient runoff; draining through delta

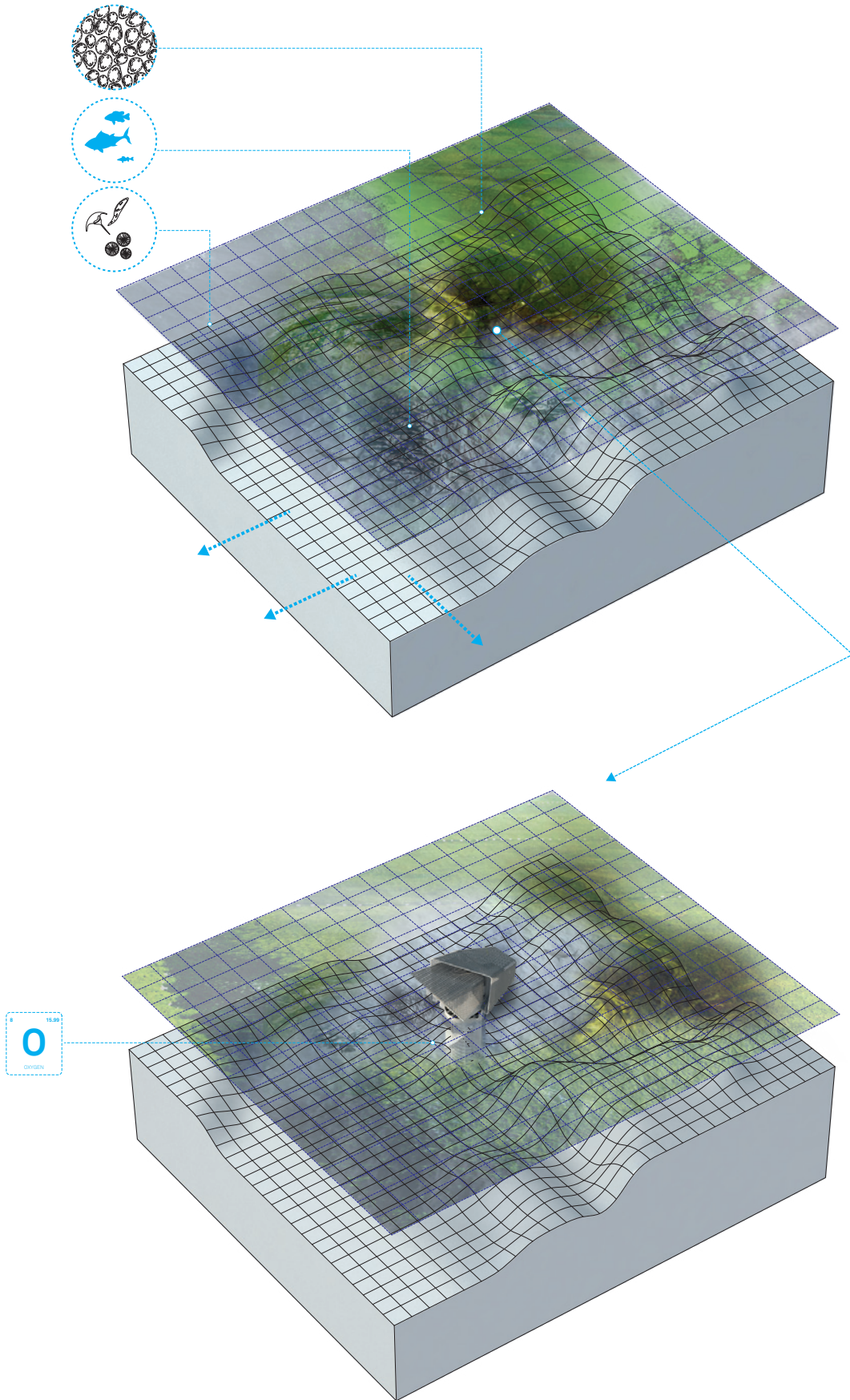

figure 1.3: Algae bloom causing hypoxia; intervention

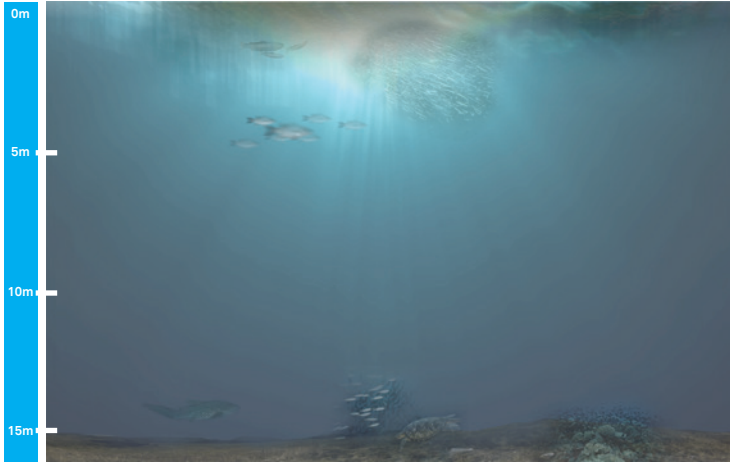

figure 1.4: fresh water nutrients from delta

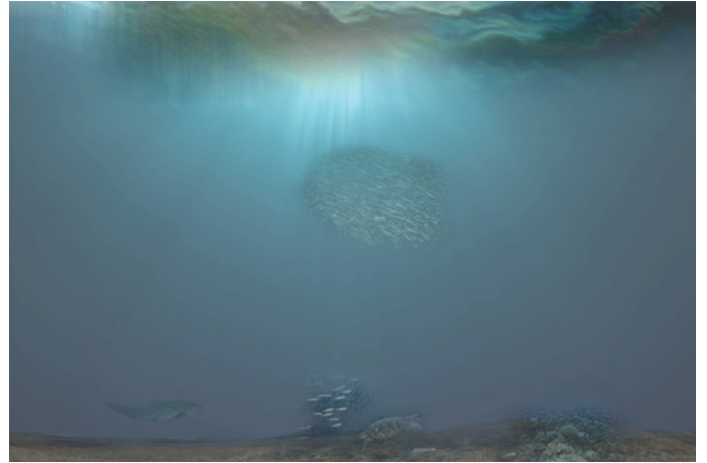

figure 1.5: algae bloom begins to form

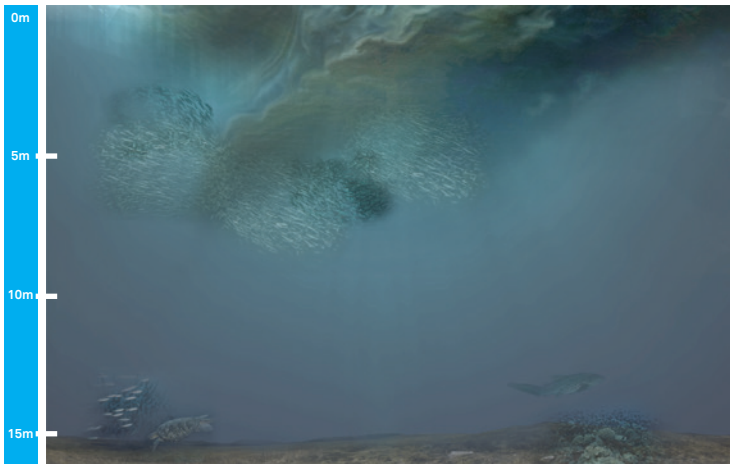

figure 1.6: dying algae causes over-population

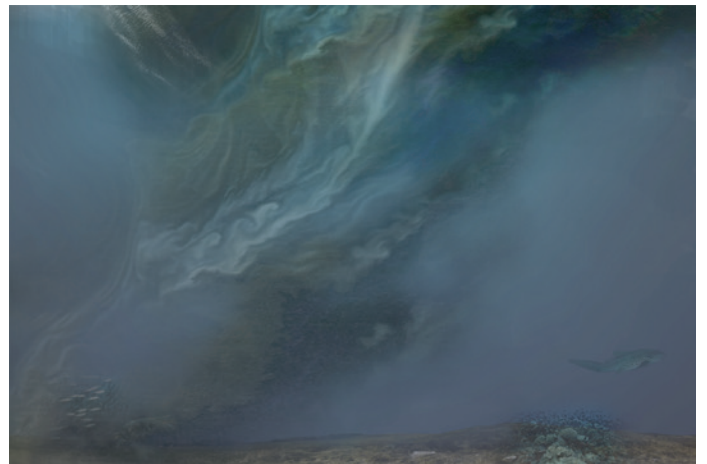

figure 1.7: algae dies and sinks to bottom

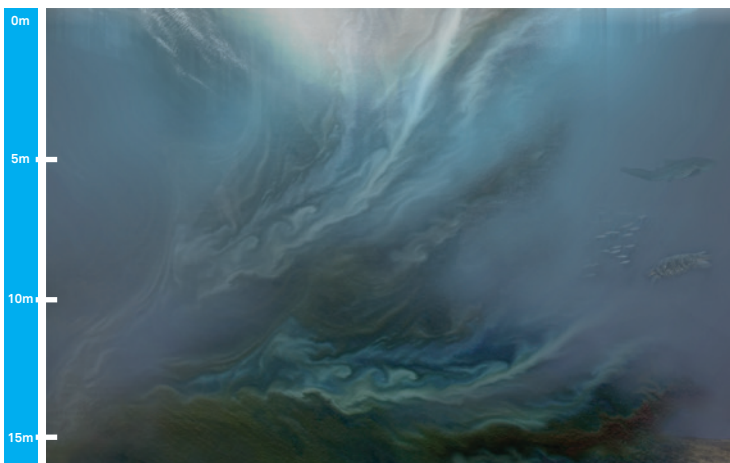

figure 1.8: oxygen begins to dissolve from bacteria

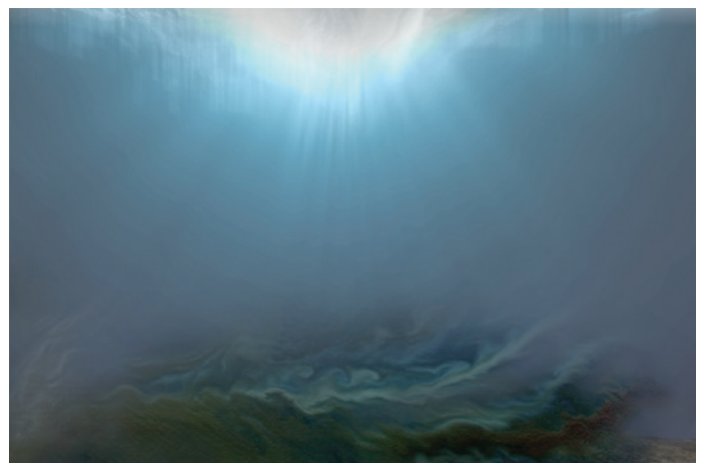
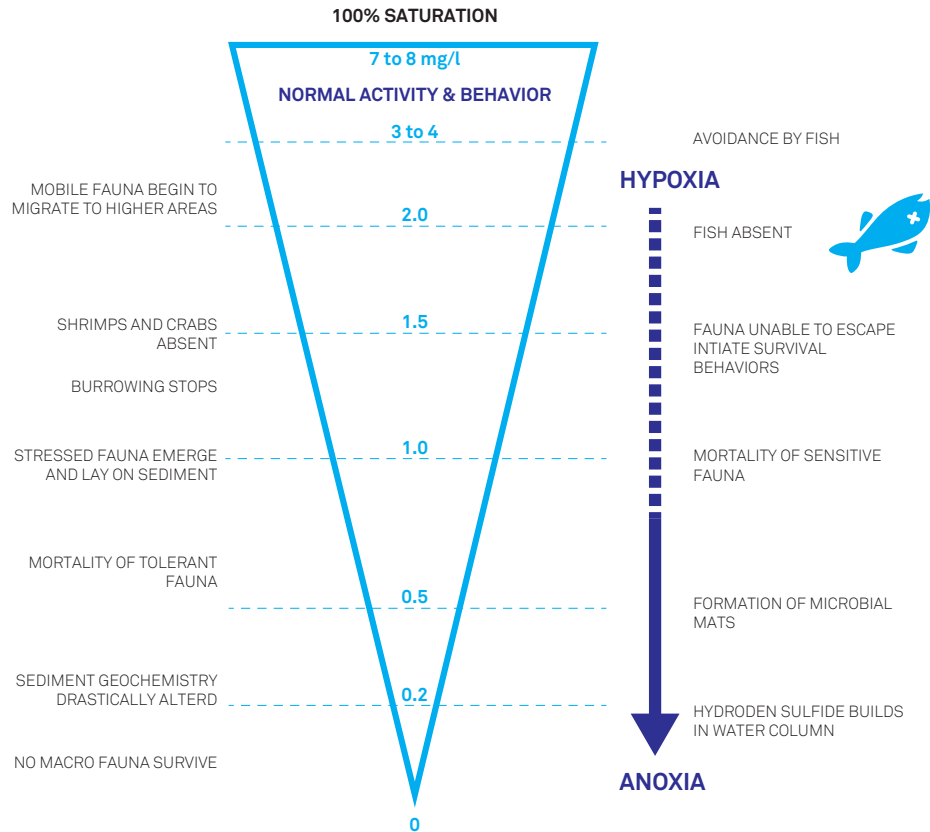

figure 1.9: area becomes hypoxic, life flees or dies



The following images on the right represent eutrophication through a sectional lense. Below are detailed descriptions of each figure.

figure 1.4

Mainly occurring within 5 to 10 meters, nutrient rich fresh water, consisting mainly of nitrogen and phosphorus drains through the mississippi basin.

figure 1.5

The excessive nutrients from the fresh water give the opportunity for algae blooms to generate during the optimal conditions.

figure 1.6

As the algae blooms form aquatic life becomes attracted to the abundance of food resulting in over population and suffocation.

figure 1.7

Once the algae dies it sinks to the benthic layer of the water column and becomes a bacteria haven.

figure 1.8

The process of the bacteria eating the algae depletes the oxygen within the vicinity rendering it unsuitable for any marine life.

figure 1.9

This last image shows the end result of the eutrophication process. All aquatic life that cannot survive in low oxygen levels will flee or die if they are immobile, hence the name 'dead zone'

At this point, the aquatic system may have areas that reach 0% saturation. A system with low concentration in the range between 1 and 30% saturation is considered Hypoxic.

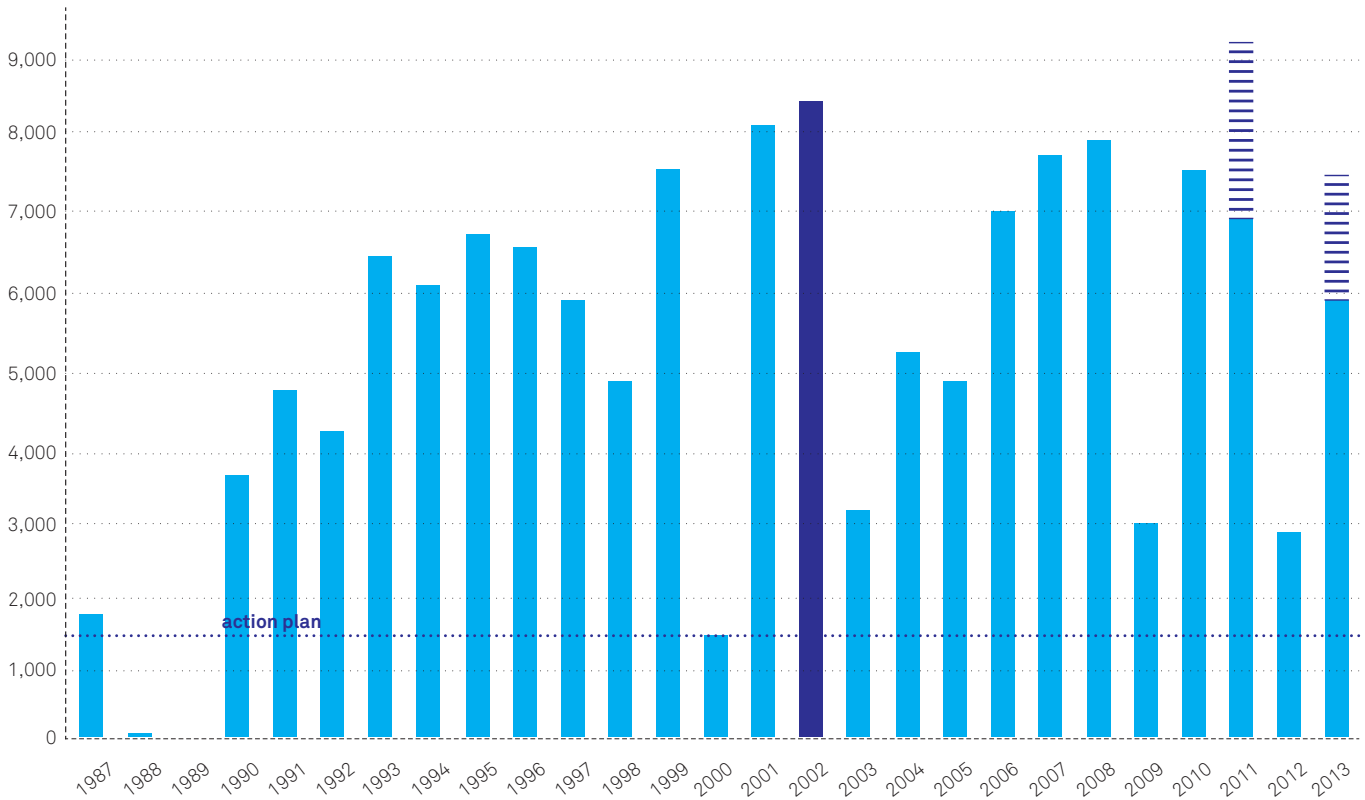
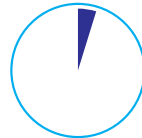
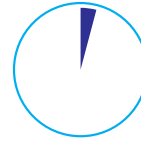
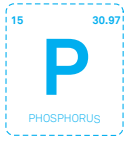

-- Hypoxia in the Gulf of Mexico --

The largest recurring hypoxic zone in the coastal waters of North America is located along the continental shelf of Louisiana and Texas adjacent to the mouth of the Mississippi and Atchafalaya River Basin (MARB). This river basin drains approximately 40% of the contiguous United States and delivers runoff with elevated nutrient levels from America's agricultural heartland to the Gulf of Mexico. The discharge of treated sewage from urban areas combined with agricultural runoff deliver c. 1.7 million tons of potassium and nitrogen into the Gulf

of Mexico every year.¹ The two nutrients responsible for blooms to occur are not harmful toxins, rather they are excess: Phosphorus, Nitrogen. As for phosphorus the total accumulates from 43% agriculture, 37% animal waste, 12% urban, and 8% natural runoff. In terms of nitrogen the total sums up to 66% agriculture, 5% animal waste, 9% urban, and 4% natural runoff. In addition, river engineering plays a very crucial role in generating larger hypoxic systems. Molding and shaping the Mississippi river actually begins to thrust the fresh water further into the Gulf of Mexico. Typically, the water draining through the basin would settle its excess nutri-

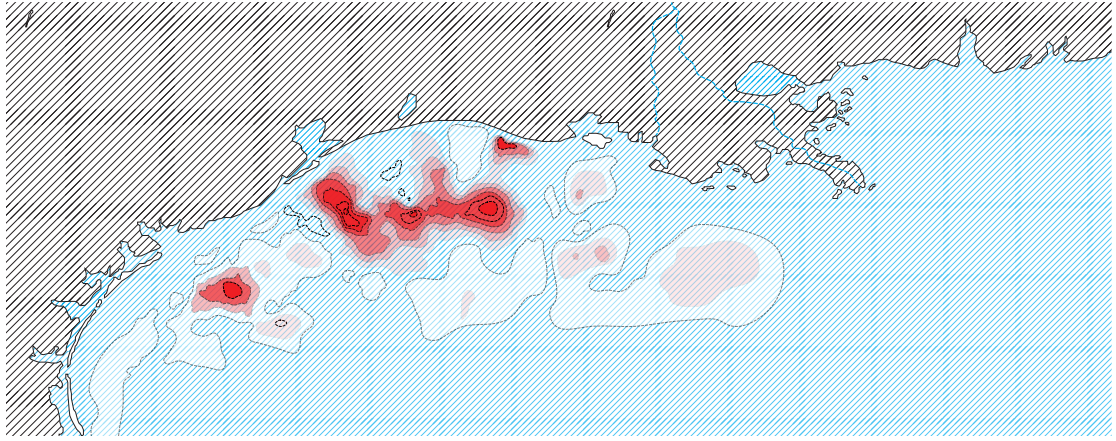

figure 1.10

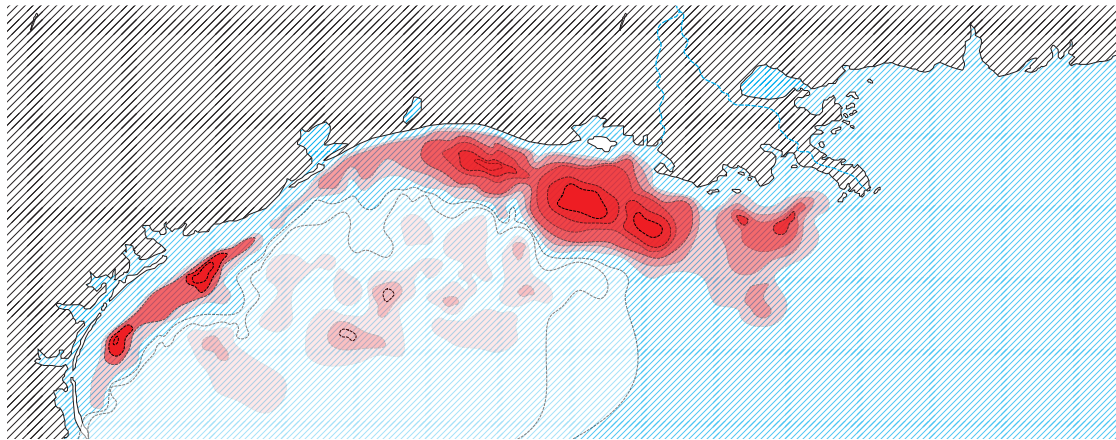

figure 1.11

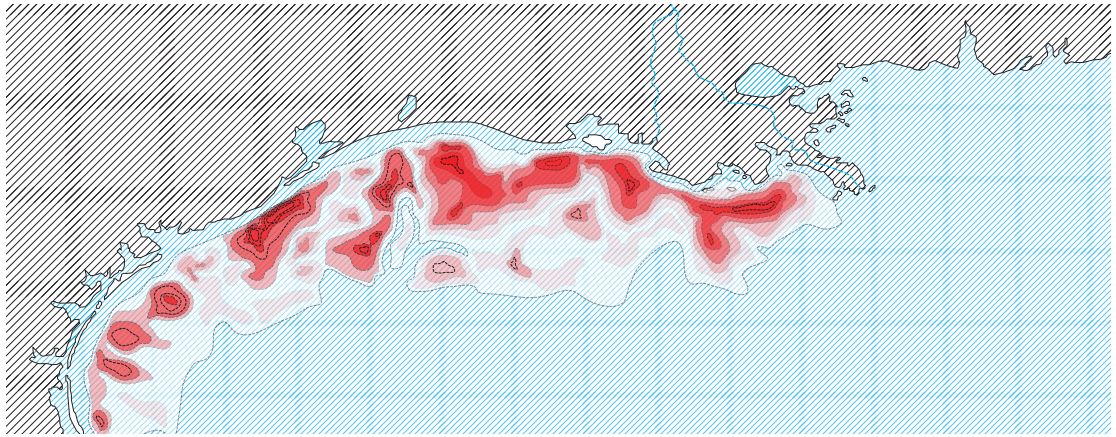

figure 1.12

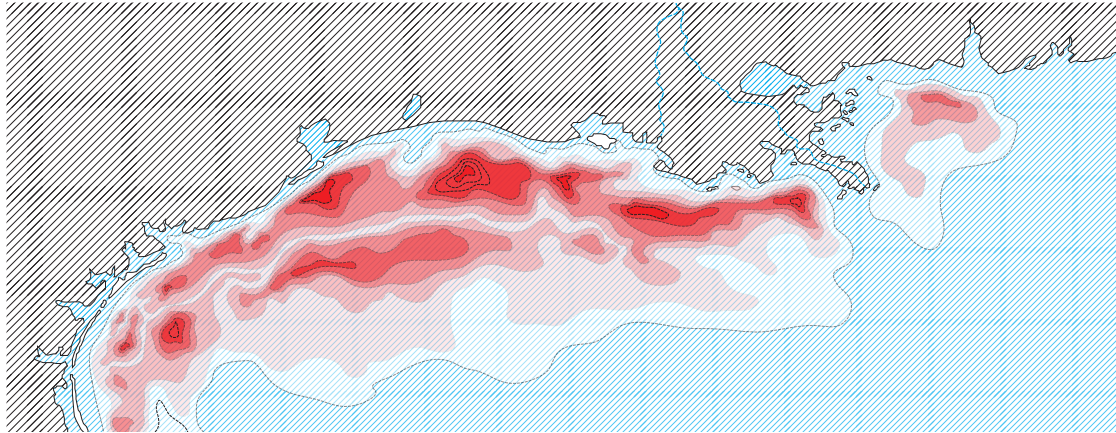
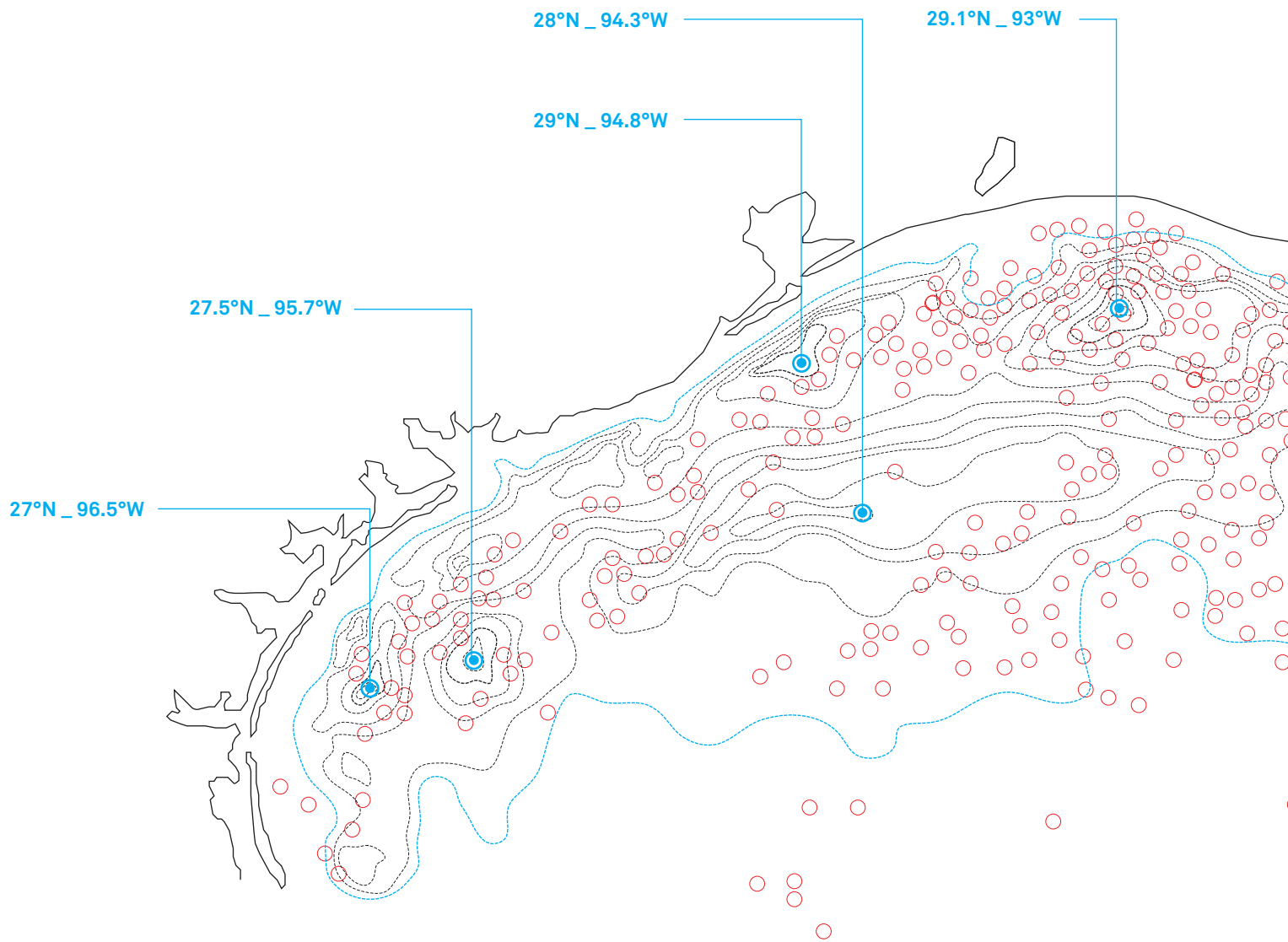

figure 1.13



ents into marsh lands and other small river tailings, now construction along the river has halted this natural landscape infrastructural system to a certain extent.

Hypoxic History

The dead zone of the Gulf of Mexico is actually a very ephemeral phenomenon. Looking back at figures 1.10 - 1.13 the NOAA has mapped the area of the hypoxic system for every year. Fig. 1.10: (2012) due to a drought, hypoxic zone diminished significantly. This system was actually at a record low when referring to the chart on pg 16. Fig. 1.11:

(2013) due to strong winds in the gulf, hypoxic zone diminished by 20%. The total expected area for this year by the NOAA was at 7,286 sq. m. yet the actual total came to 5,840 sq. m. Fig. 1.12: (2011) again, due to a drought, hypoxic zone diminished significantly. However, this system was very substantial. Fig. 1.13: (2002) largest hypoxic system ever documented.

The Systems Symptoms

Hypoxia effectively reduces the available marine habitat, which is a significant concern because the Gulf of Mexico supports over

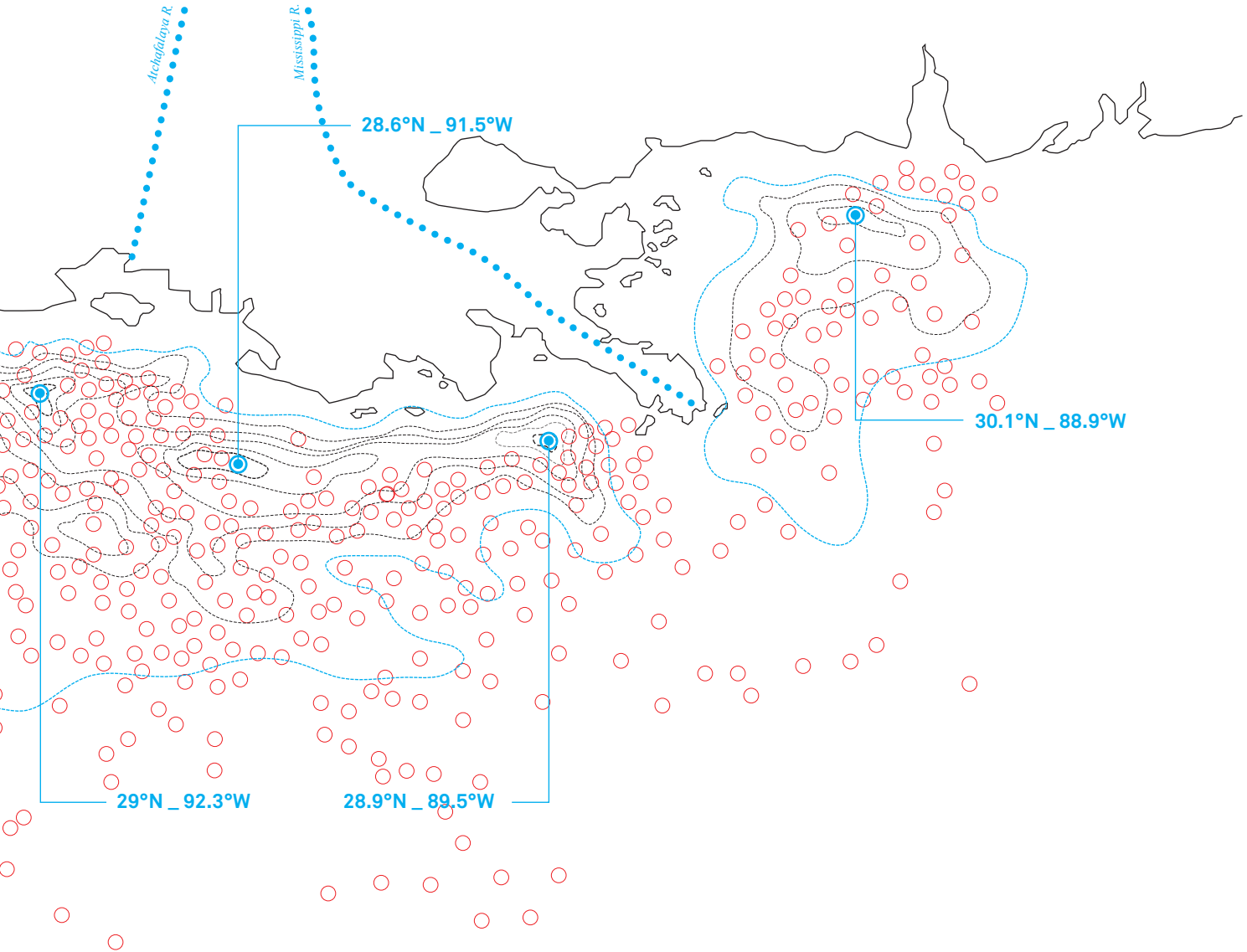

40% of the nation's commercial fishing with typical annual yields of more than a billion pounds of fish with a total market value of around \$700 million.² Dwindling fish stocks and increased travel distances to access fertile water has resulted in decreasing fuel efficiency across the global fishing industry, which consumes approximately 50 billion liters of fuel per year.³ In addition, low oxygen levels in the Gulf create a benthic layer on the ocean bottom that is dominated by metal or sulfur reduction bacteria, which contribute to stark color and odor difference in the hypoxic zones.⁴ The resulting smell and discoloration is objectionable and can have detrimental effects on recreational ac-

tivities and tourism. The map above represents the network infrastructural system of hypoxic zones over the years overlaid from the data collected by the NOAA which reveals the pinpoint areas of hypoxia severity. Each red circle represents an offshore petroleum platform, clearly the fossil fuel business is not helping the situation

1. NOAA, 2012
2. NOAA, 2009
3. Tyedmers et al., 2005
4. Chih-Ting Kuo, 2010

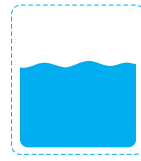

TEMP

PRECIPITATION

SEA DEPTH

WINDS & STORMS

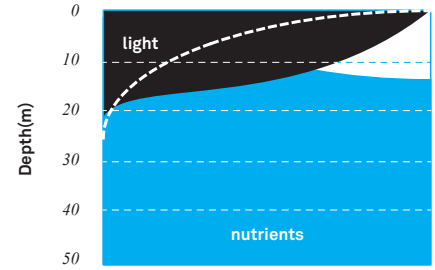
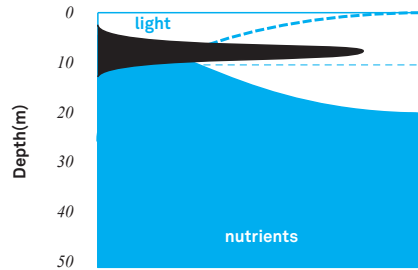
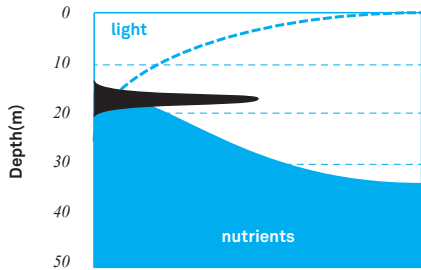
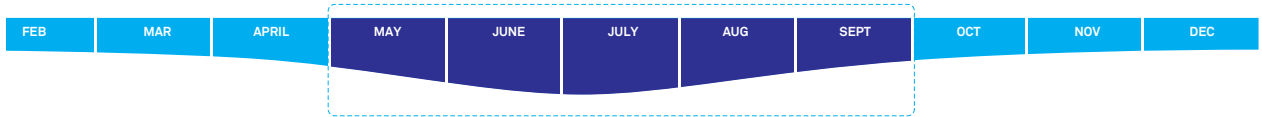
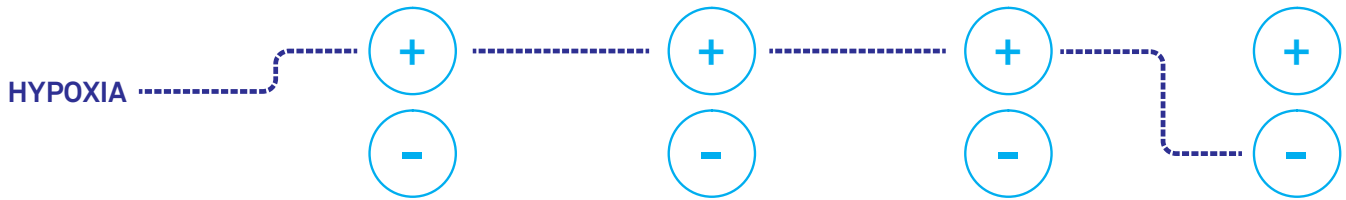

Algae Depth Growth

Algae growth depends on several factors including: temperature, precipitation, sea depth(usually 5 - 10m), and storms. However, algal communities are not always floating at the surface. Algae require both light and nutrients to grow phototrophically, and therefore position themselves in the water column to find conditions where both light and nutrient concentrations are sufficient.¹

However, in the ocean the light sufficient zones and nutrient sufficient zones are not necessarily co-located. Algae grow best at a depth where favorable light and nutrient conditions intersect. Therefore, at the location near the coast or estuary where there is strong mixing throughout the whole water column, the algae usually have highest density at the ocean surface.²

Algae Typologies

In the Gulf of Mexico, diatoms are the dominant biomass communities of many marine and estuarine areas, particularly in spring. Diatoms and other phytoplankton are estimated to be 40% of the amount in January and February. Picocyanobacteria are the dominant species for most of the time, from May to November. Dominant communities in the Gulf of Mexico from 1990-1995.³ The abundance of diatoms and other algal species are indicated by left vertical axis, the abundance of picocyanobacteria shows in right vertical axis.

1. Sutor, 2007
 2. Chih-Ting Kuo, 2010
 3. Dortch et al., 2001

Dominant communities of algae in the Gulf throughout the year

~ University of Illinois at Urbana-Champaign, 2010

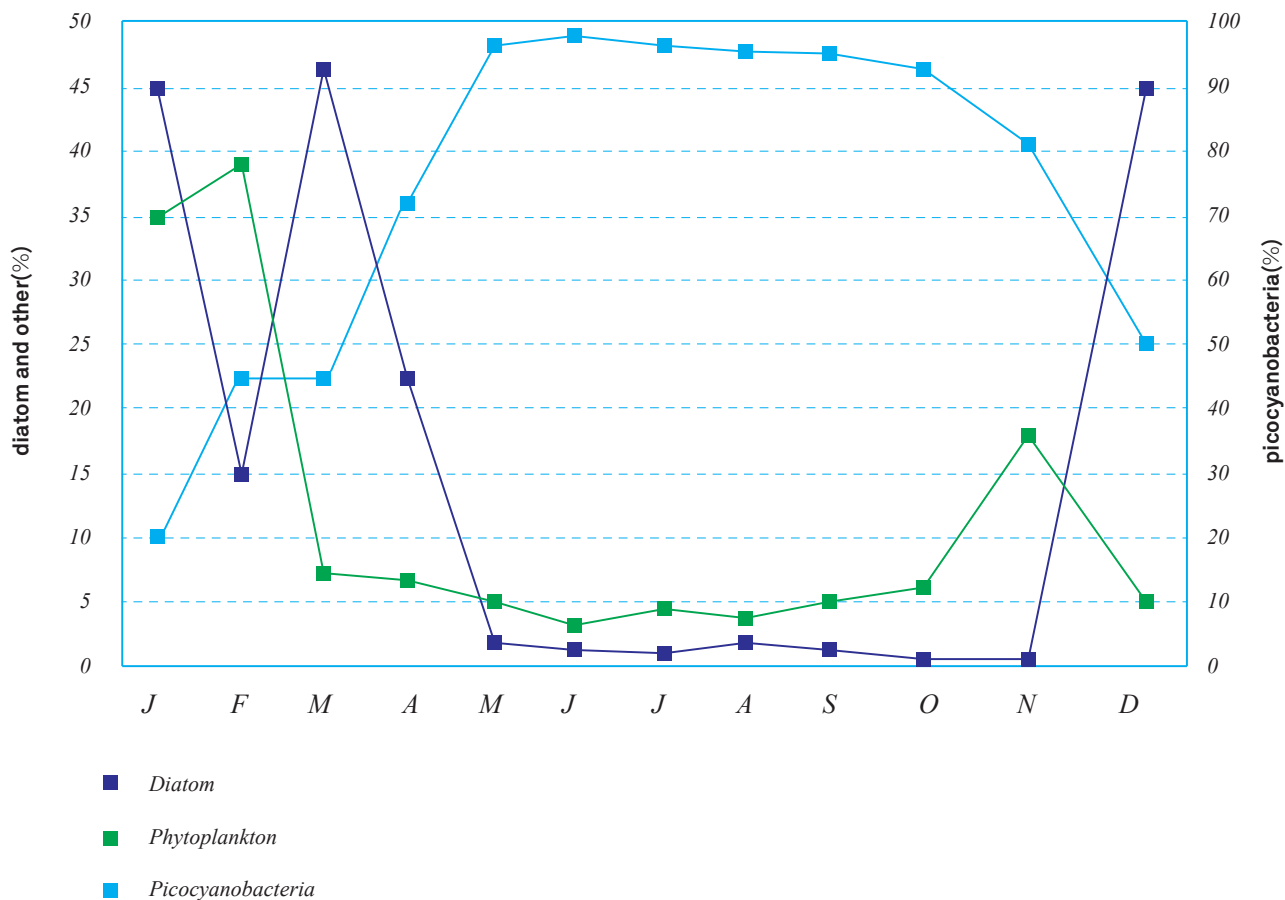

Common algae species biochemical composition

~ University of Illinois at Urbana-Champaign, 2010

Species	Chlorophyll(%)	Protein(%)	Carbohydrate(%)	Lipid(%)	Ash(%)	Size(µm)
<i>Diatom average</i>	1.5	30	18.0	20	N/A	N/A
<i>Skeletonema costatum</i>	1.8	37	20.8	6.9	39	30
<i>Chaetoceros calcitrans</i>	1.5	34	6.0	16	28	80
<i>Thalassionema nitzschioides</i>	0.95	34	8.8	19	N/A	10~110
<i>Rhizosolenium</i>	N/A	36	28.7	34.8	N/A	6~9
Picoplankton Average	1~3	56.1	19.8	16.9	7.2	<2
<i>Synechococcus</i>	N/A	63	15.0	5	N/A	N/A
<i>Chlorophyceae Nannochloris</i>	1.6	30	23.0	21	26	2
Dinoflagellate						
<i>Karenia brevis</i>	5.8	20.9	46.5	11.6	15.11	18~45
<i>Phytoplankton</i>	N/A	20.8	22.3	45.7	11.2	2~20

DEADZONE

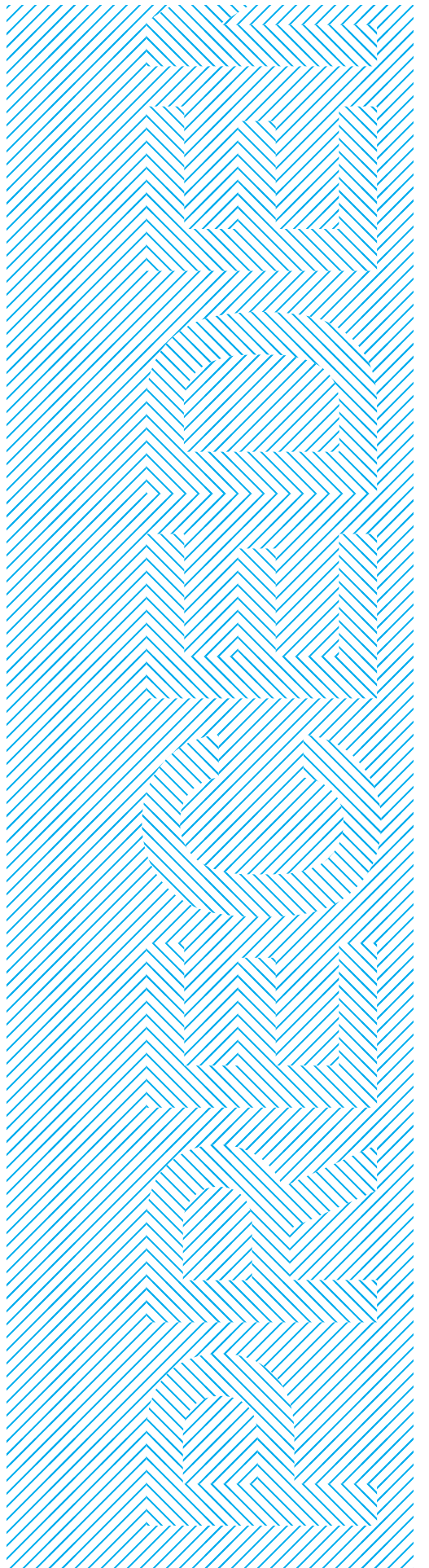

Precedents

By no means is this thesis demanding that all inland agribusiness or offshore petroleum production be discontinued nor be repurposed, but rather fostered or driven into the direction of architectural adoption. The precedents that have been most important to the dead zone were maritime structures for hydro-carbon based workforces. In particular, the offshore petroleum platform called a SPAR.

Despite the hazardous nature of offshore oil extraction, this resource is clearly of high demand carrying not only the epitome of greed from big oil supermajors such as BP, Shell, or Texaco, but simply the need for oil considering the vast infrastructural systems residing inland. Currently in the 2012 US energy use poll, 37.13% of energy used is petroleum. However, out of all the energy only 42% is actually used and the other 58% is wasted primarily from electricity generation. Workforce dystopias like Stalin's Neft Daslari have been created solely upon the means of producing petroleum, now the constructs are left as environmental ruins rotting away in the Azerbaijan Sea. Currently in the Gulf of Mexico, 3,858 American oil platforms are operating, not including deep-water wells. In terms of future development, if America were to become an oil independent nation, removing the platforms solely off the coast of Louisiana will estimate to costs over 4 billion dollars. For instance, in 1995 the cost of removing all platform rig structures entirely in British waters was estimated at £1.5 billion. Additionally, the cost of removing all structures, including pipelines, in what was called a "clean sea" approach was estimated at £3 billion. Some institutes have suggested an alternative to deconstruction, which is to utilize the abandoned infrastructure as artificial reefs.

According to United States Marine Biologist Milton Love, the implementation of artificial reefs have been havens for many of the species of fish which are otherwise declining in regions such as the Gulf. In 1979, a nationwide program called Rigs-to-Reefs (RTR) was developed by the former Minerals Management Service (MMS) to turn decommissioned offshore oil and petroleum rigs into artificial reefs by severing the rig from the bottom using explosives (also known as toppling). MMS research shows fish densities are 20 to 50 times higher around oil and gas platforms than in nearby open water. Multiple companies have donated over 200 platforms to the effort today.

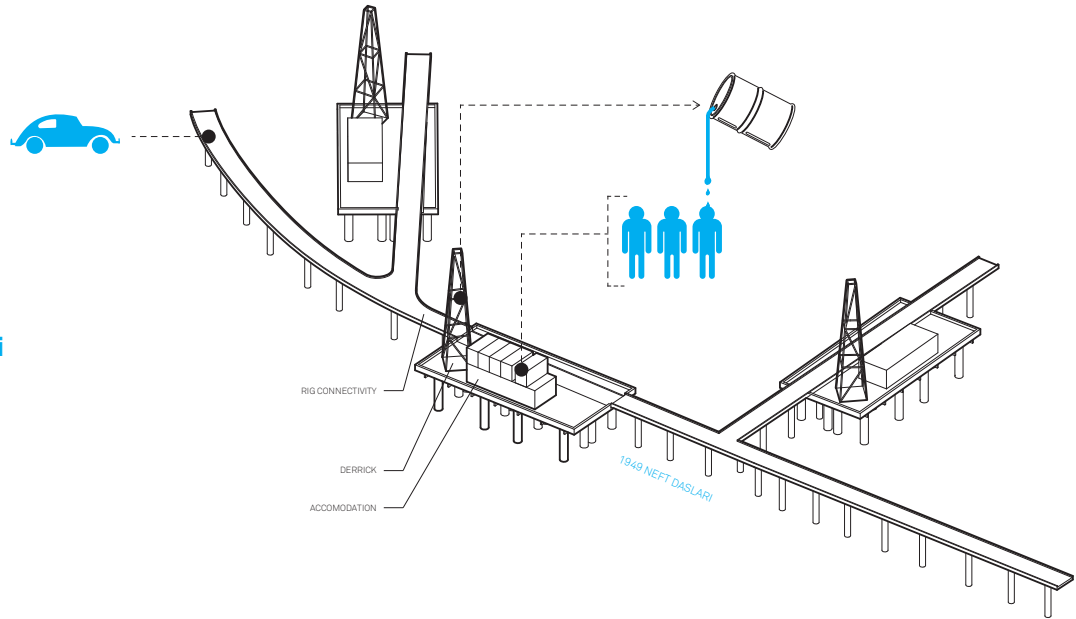

Stalin's Neft Daslari

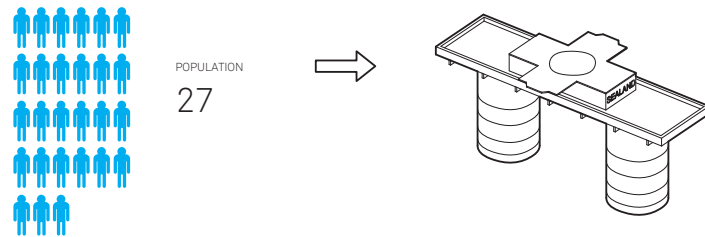

Principality of Sealand

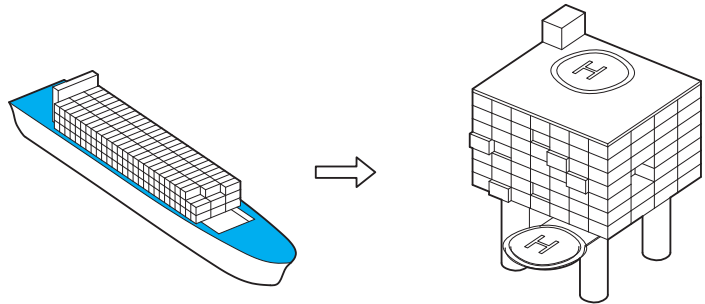

Hotel Oil Rig

(Top left: Stalin's Neft Daslari. Middle Left: Principality of Sealand off the coast of England. A repurposed sea fort. Bottom left: repurposed oil rig to be a luxury hotel in the Gulf of Mexico.)

-- Offshore Platform Typologies --

In order to build on the design criteria, this proposal analyzes a series of offshore oil platform technologies beginning with its earliest methodologies.

Beginning in the late 19th century at Grand Lake, Ohio traditional oil drilling achieved its first leap: surpassing the constraint of water. Since then, the offshore oil drilling evolution accelerated rapidly overcoming variables such as establishing foundation to the sea floor, remaining structurally sound within hostile seas, the assembly processes, buoyancy, and disaster (oil spill / fire). Today the forefront of offshore platforms are revolving around semi-submersible structures (Jackups, drill- ships, semi-subs, barges, and SPAR platforms) that offer a more flexible resource extraction network.

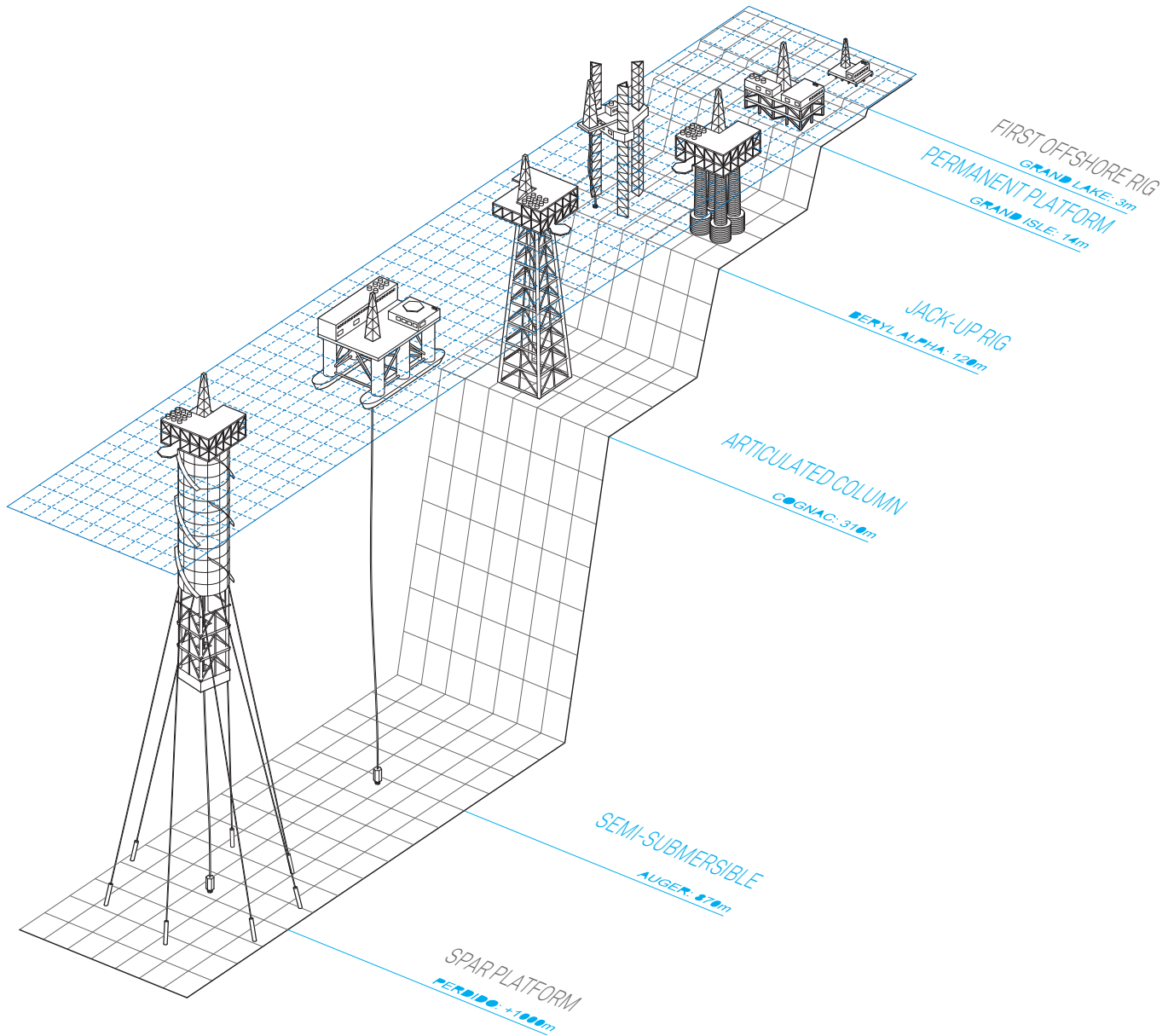

Oil Rig Evolution

Fixed Platforms

Usually containing a floating drilling tender and are unsuitable for hostile seas. The tender is moored to the rig and provides power supply, mud pumps, mud pits, pipe racks, storage space, misc. equipment, and accommodation for the platform crew.

Self Contained Fixed Platforms

In this category there are two typologies: the concrete gravity platform reaching 800 ft in depth, and the tubular steel reaching 1100 ft. The concrete gravity is better for deeper more hostile sea because of

its stability and method of construction (continuous pour to form pillars). Built in a drydock, towed in an upright position and sunk. Most contain a ring of cylindrical concrete tanks surrounding the base which provide storage for oil awaiting transport. The tubular steel is built on its side and floated out to its location as well. Sinking carefully using steel buoyancy bottles attached to the legs.

Submersibles

Reaching 100-175 feet of water emerging from the swamp barge

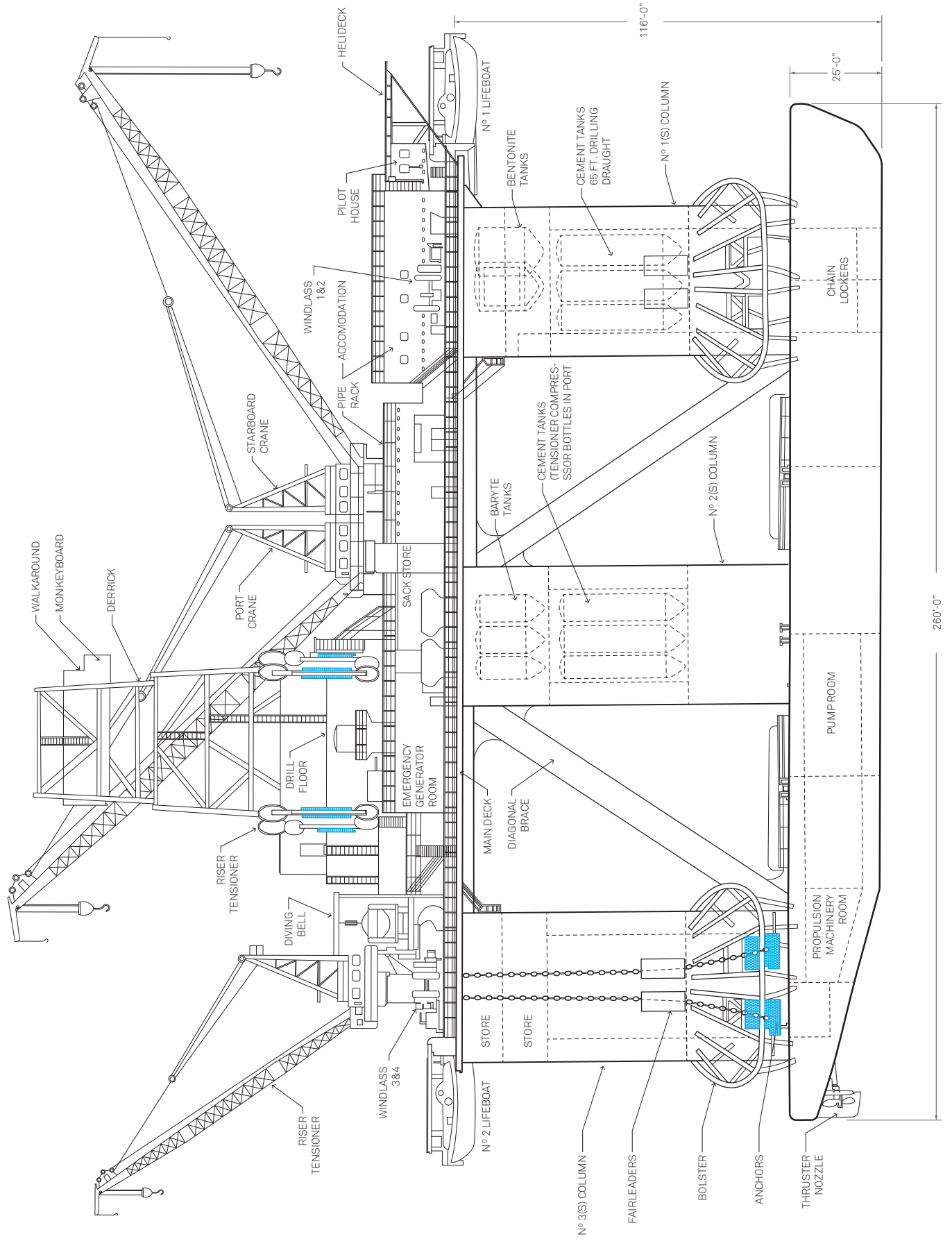

WALKAROUND
MONKEYBOARD

DERRICK

STARBOARD CRANE

WINDLASS 1&2

PIPE RACK

ACCOMMODATION

HELIDECK

N° 1 LIFEBOAT

BENTONITE TANKS

CEMENT TANKS 66 FT. DRILLING DRAUGHT

N° 1(S) COLUMN

CHAIN LOCKERS

CEMENT TANKS (TENSIONER COMPRESSOR BOTTLES IN PORT)

BARYTE TANKS

N° 2(S) COLUMN

PUMP ROOM

PROPULSION MACHINERY ROOM

MAIN DECK

DIAGONAL BRACE

STORE

STORE

N° 2 LIFEBOAT

WINDLASS 3&4

RISER TENSIONER

DIVING BELL

RISER TENSIONER

DRILL FLOOR

PORT CRANE

SACK STORE

EMERGENCY GENERATOR ROOM

N° 3(S) COLUMN

FAIRLEADERS

BOLSTER

ANCHORS

THRUSTER NOZZLE

116'-0"

25'-0"

260'-0"

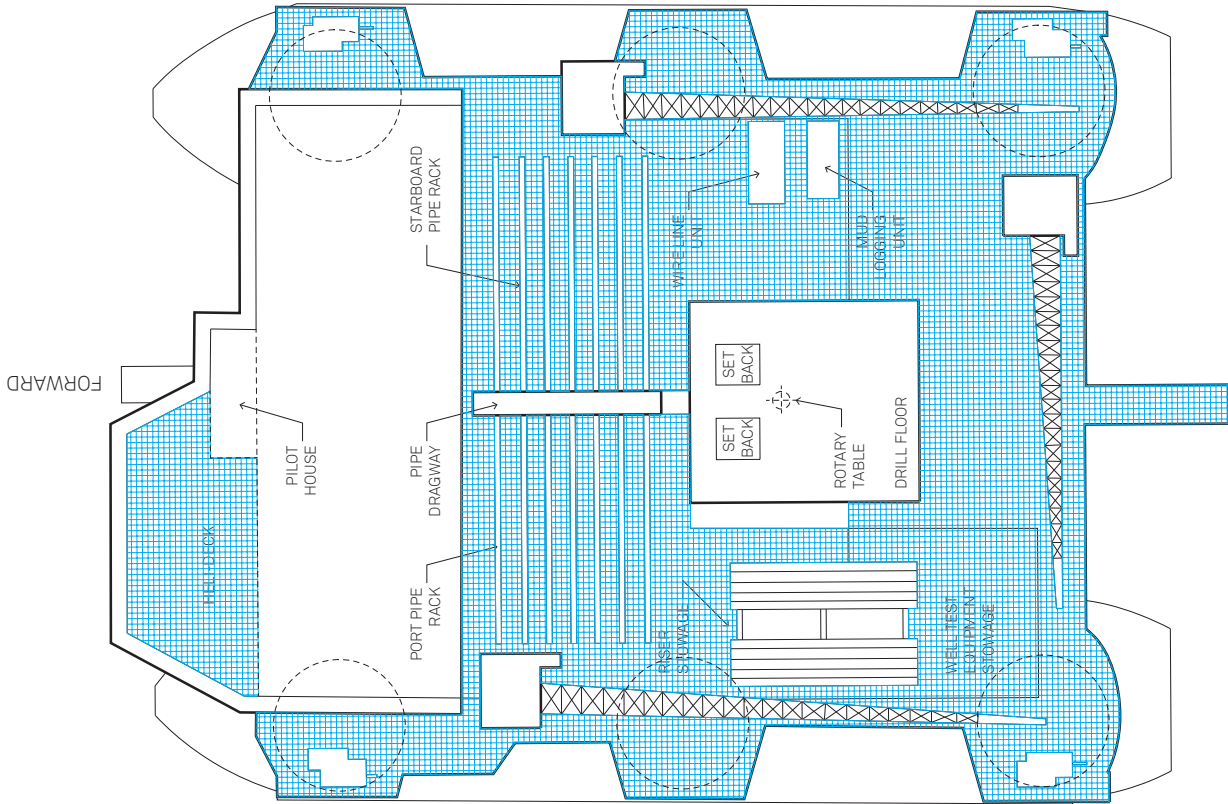

PLAN VIEW

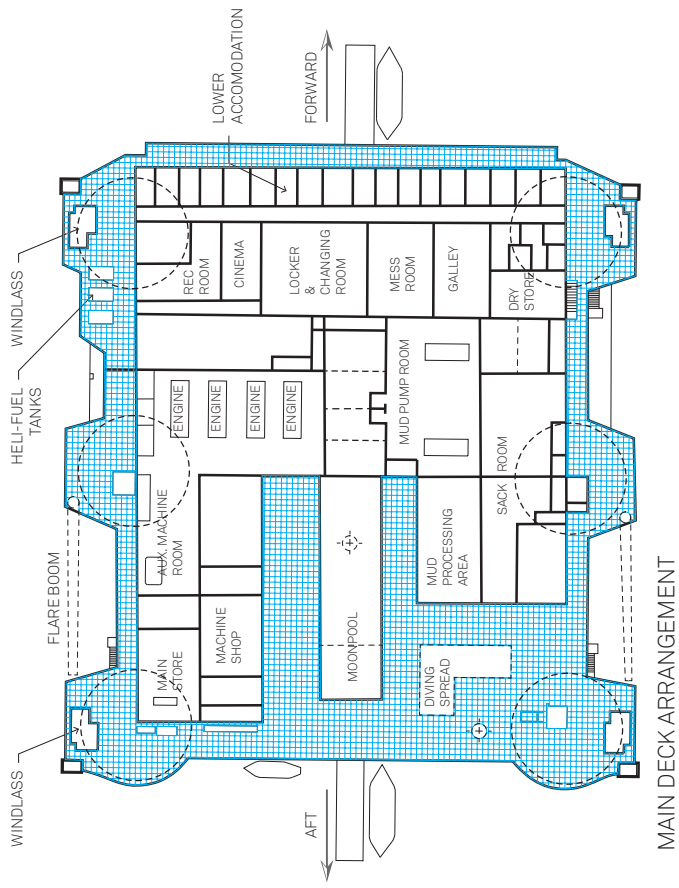

MAIN DECK ARRANGEMENT

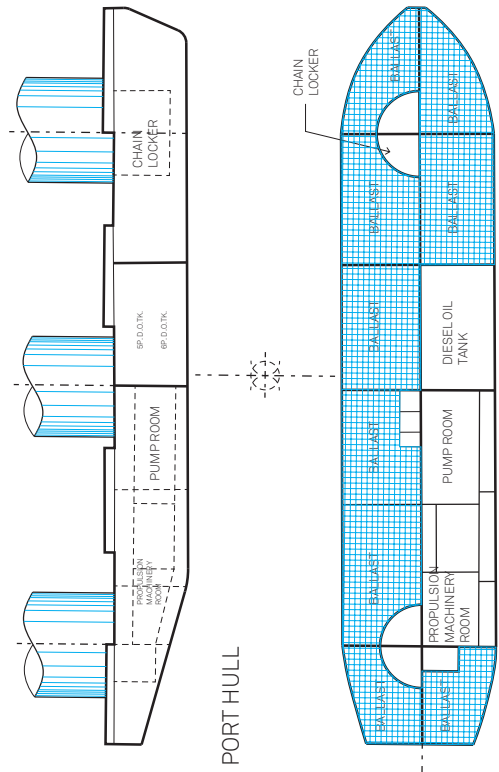

LOWER HULL ARRANGEMENT

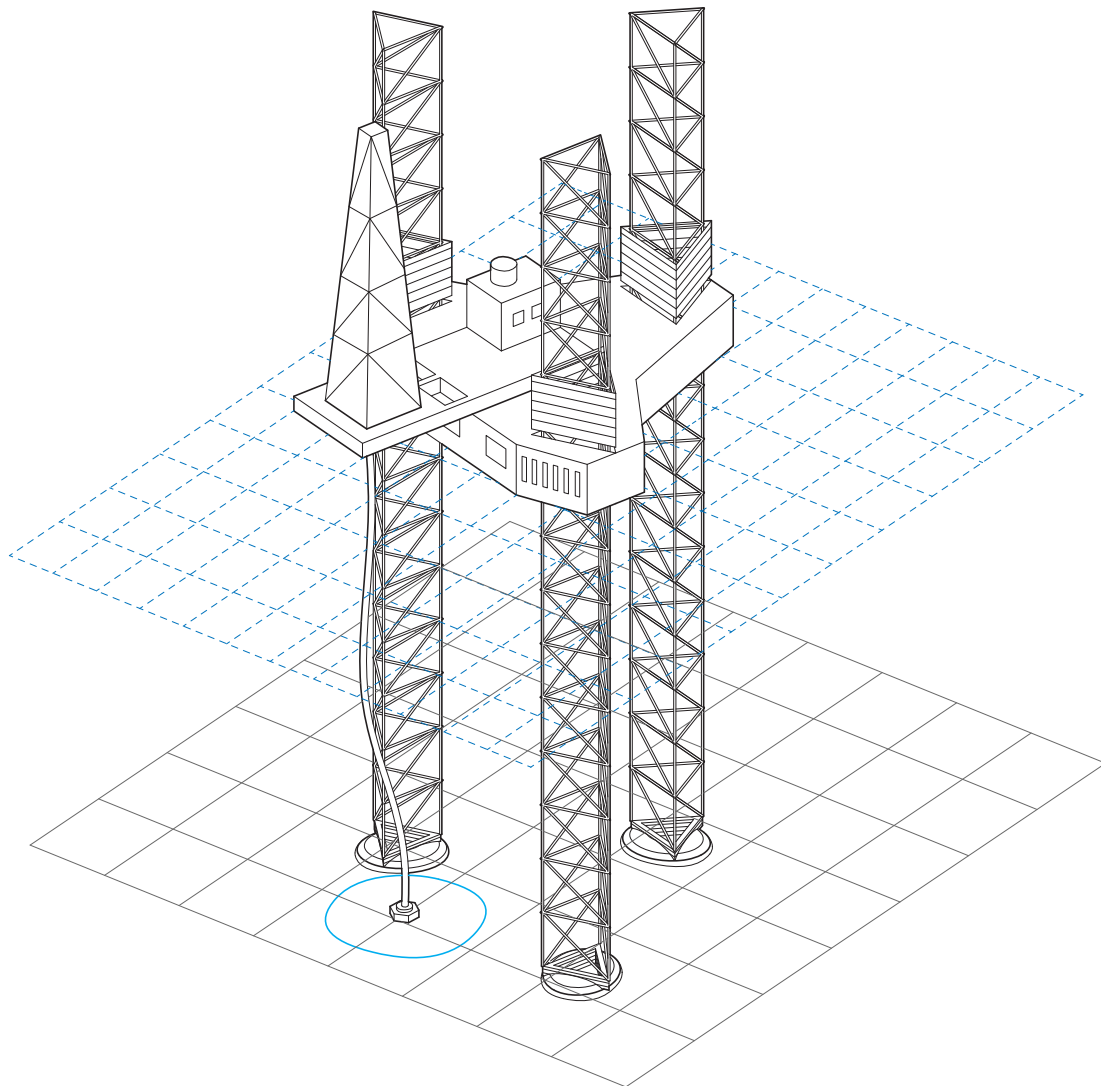

Jack-up Platform

which rests on the bottom by ballasting down. This causes problems with underwater currents. Only seen in the Gulf of Mexico and Nigeria. Precedent to the Semi-Sub.

Self-Elevating (Jack-up) Platforms

Containing a main floating hull with large truss legs and spud cans reaching the sea floor to thrust the hull 20 meters above sea level. Reaching depths of 400 ft. meaning the the legs protruding through the hull must be 600 ft. tall. Most rigs are not equipped with propolsion, meaning they have to be towed by special ships. These platforms are only used to drill the well. Once drilled, the well is plugged and the jack-up moves on to another site. Then a permanent rig is placed over the well to extract oil. Accomodation includes 38 - 2 men cabins, 2 - 1 man cabins, and 1 - 3 man hospital. Power supply: 3 - 12 cylinder su-

percharged diesel engines.

Semi-Submersibles

BP's Deepwater Horizon. Most versatile and mobile of all drilling platforms. Using ballast to sink the hull slightly mitigating hostile seas. Contains a derrick, accomodation for the crew, pontoons for ballasting, and other specifics not included in most rigs. There has been issues with this particular floating design due to movement cause by hostile seas. Hostile seas creates verticies around the supporting legs of the structure which forces the platform to rock back and forth. This motion has the tendency to rupture pipelines or even the drill shaft itslef which may be the reason why massive oil leaks occur.

(see pg. 26 - 27 for more detailed drawings of semi-submersibles)

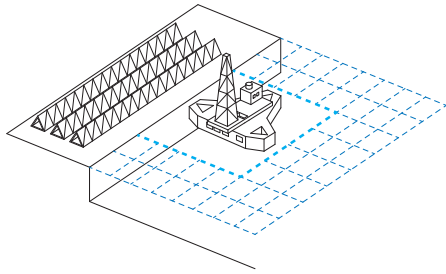

CONSTRUCTION

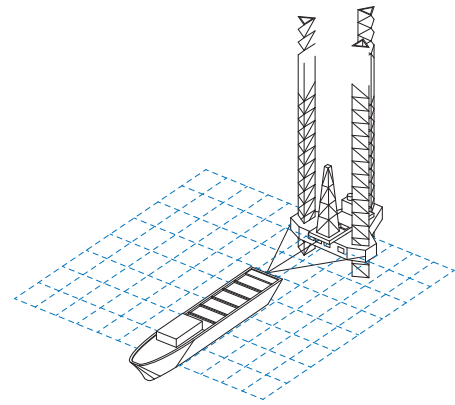

TOW TO SITE

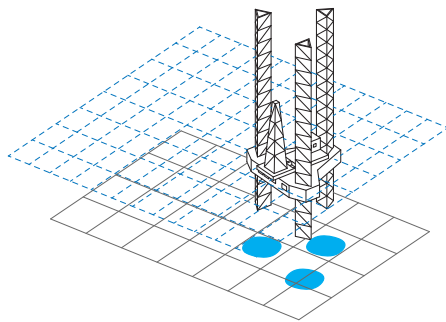

DROP LEGS TO SEABED

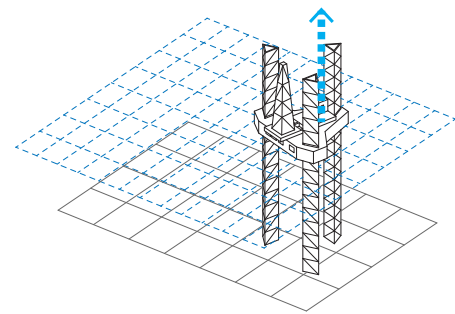

RAISE HULL ABOVE SEA LEVEL

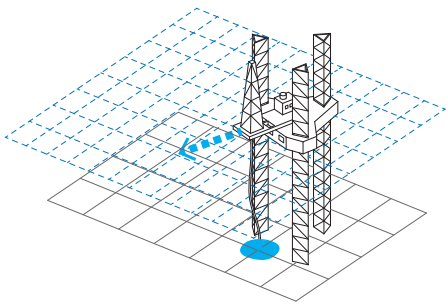

PREPARE DERRICK FOR DRILLING

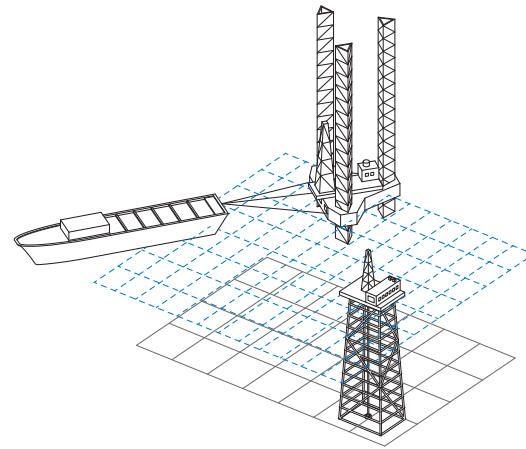

CAP WELL AND RELOCATE

Spar Platform

Derives from logs used as buoys in shipping that are moored in place vertically. The SPAR platform uses simple engineering techniques involved with geometry, weight, and tension to mitigate hostile seas and create a safer environment. This typology, forefront of offshore petroleum extraction, reaches the deepest oil fields currently up to 2,438 meters costing up to \$3 Billion. However, these structures haul in an incredible amount of oil per day using techniques such as directional drilling. After the SPAR is made in a dry dock. The assembly process only takes 2 days. The large steel cylinder is towed to the oil

field, filled with water in specific ballast positions in order to tilt the structure upright. Second, the platform is lifted by two large cranes from barges onto the SPAR unit. To prevent top siding spud cans are deployed where air is sucked out and the cap then drives itself into the ground. Furthermore, to mitigate sway from hostile seas strakes are applied. These strakes tames the verticities making the oil platform spill proof as well as sea sick proof. Last, a tank located at the base of the belly is filled with permanent ballast, or 13,000 tons of pulverized iron ore offering a low center of gravity. The SPAR platform is essentially hurri-

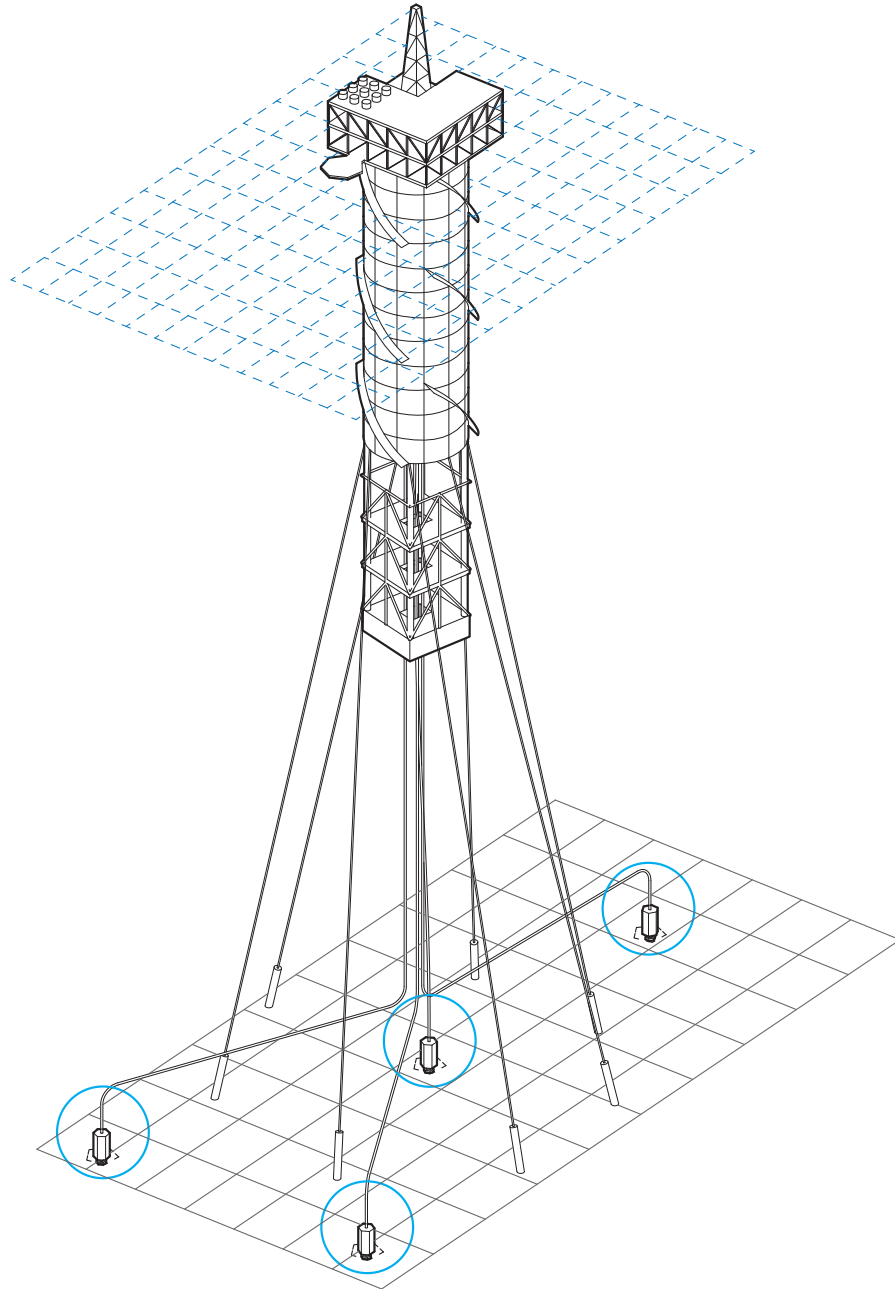

Spar Platform

cane, 30 meter wave, and almost bomb proof. Subtleties in form may start to occur according to appropriate depth and location of the platform.

An engineering firm called Goodfellow Associates Limited have also developed the idea of a semi-spar platform for the potential of small oilfield extraction processes. The design concept consists of a ring-shaped buoyancy structure with six ballast columns below. The deck structure is supported on the six piercing columns. The flarebooms, helideck, and tanker mooring point are all able to rotate. In the operating condition stability is provided by a 12 point mooring system.

Cost

Drilling an offshore well can cost ten times as much as drilling a land well, and an operator's expenses might well run to \$100,000 a day for 100 days or more. The overall costs of any exploratory drilling venture can be grouped under three main headings: initial costs, equipment costs and operating costs. Initial costs cover the preparatory work necessary before any drilling starts, including seismic surveying, the purchase of a license and the annual licence rental fee. Most offshore operators hire the services of specialist contractors to carry out nearly every function onboard a

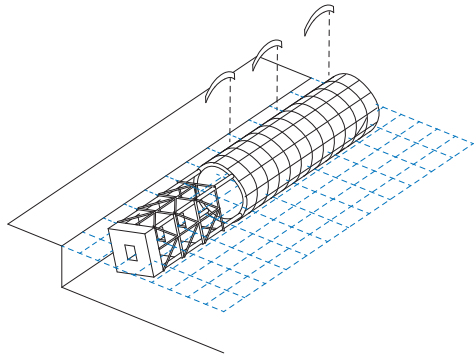

CONSTRUCTION

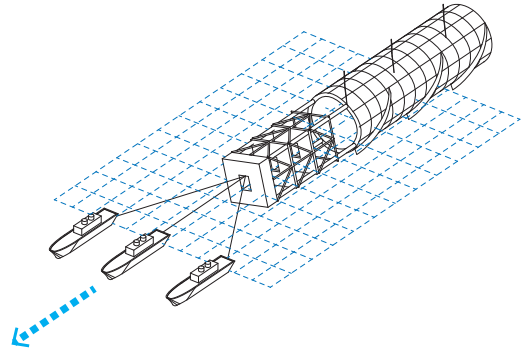

TOW TO SITE

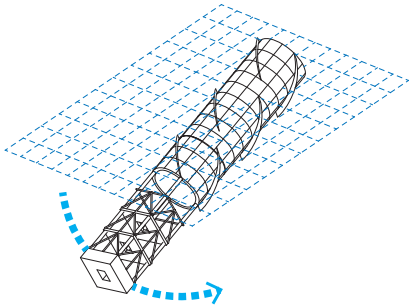

BALLAST INTO POSITION

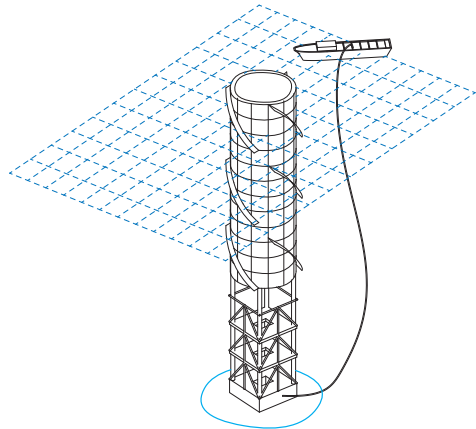

PERMANENT BALLAST FOR STABILIZATION

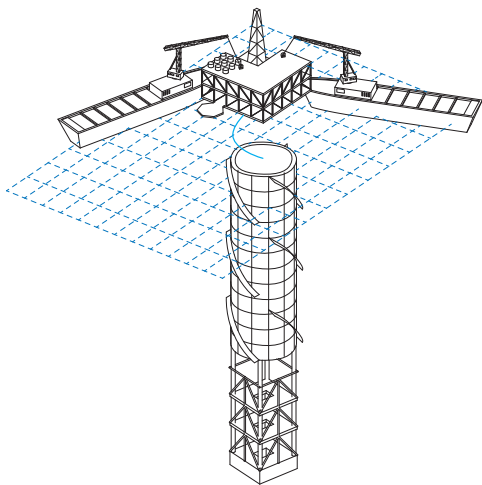

MAIN OPERATING DECK

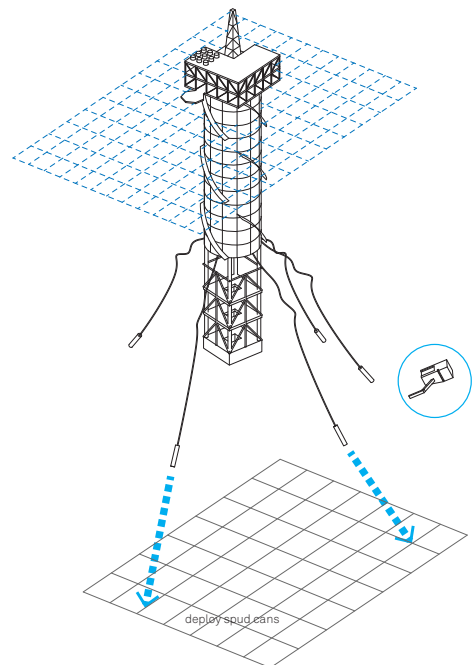

deploy.squid.cans

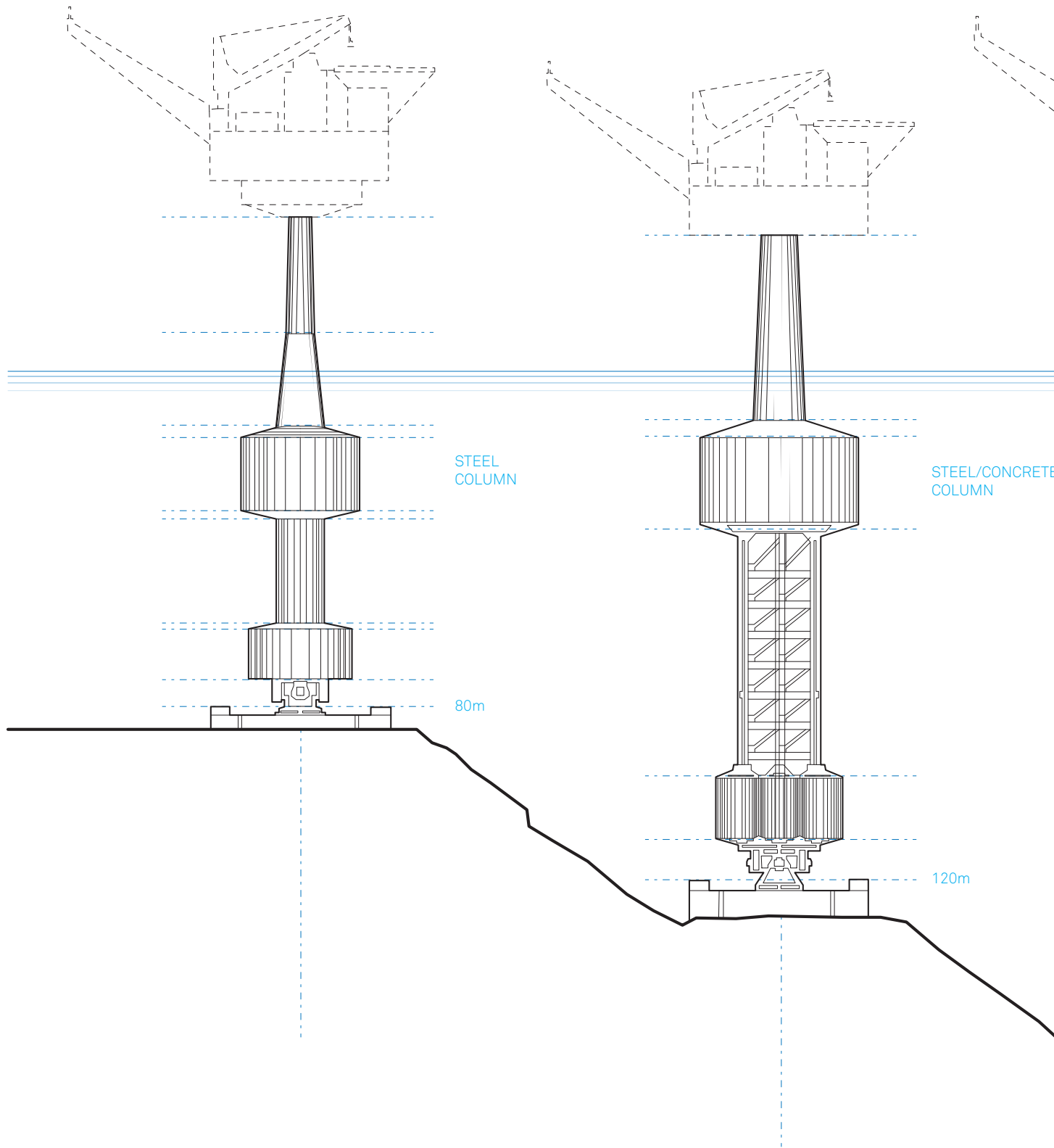

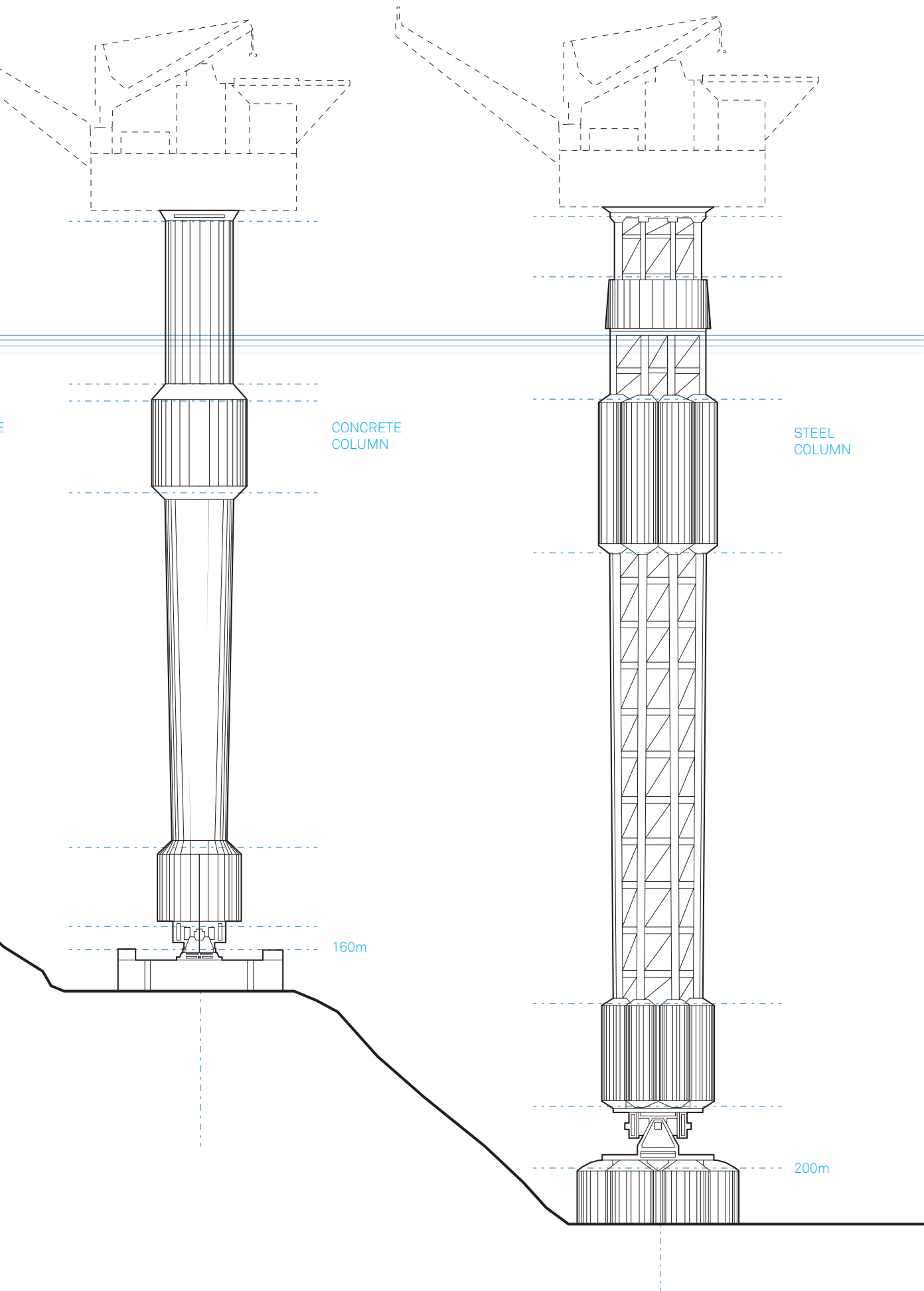

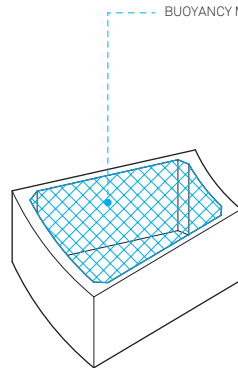
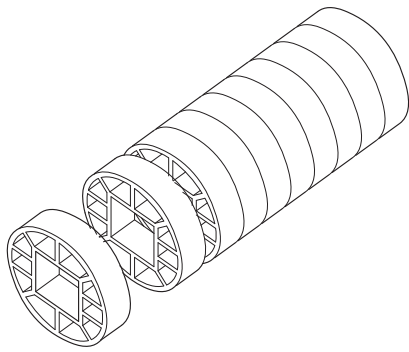

BUOYANCY MODULE

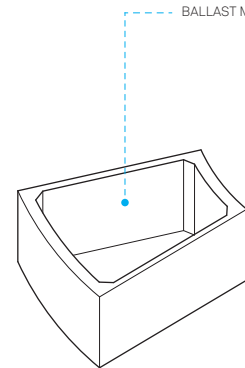

BALLAST MODULE

Precast-Concrete Modules

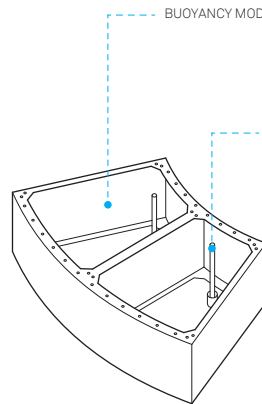
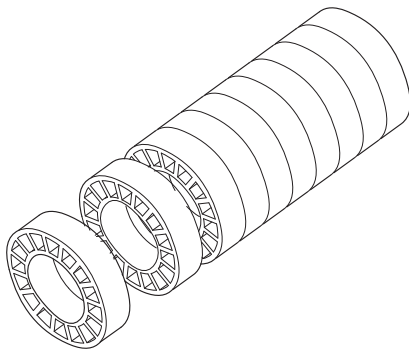

BUOYANCY MODULE

DOUBLE WALLED PIPE

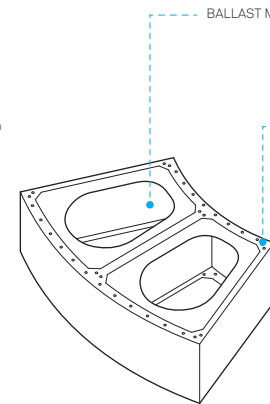

BALLAST MODULE

POST TENSIONED CONDUITS

Steel-Truss Modules

Interior Geometry

drilling unit including the actual drilling operation itself, and their own equipment costs are therefore low. A few Majors such as Shell and BP, however, still own their own rigs, unlike most oil companies which hire drilling contractors' units and crews on a time basis. The latest semi-submersibles, which can drill holes 25,000 feet deep, cost more than \$110 million to build, even before the drilling tools are put on-board.¹

Geometry

The geometry of any oil construct will depend on several aspects;

however, an important consideration in the design or selection will be the stability and required payload. The stability will generally be governed by the requirements of a regulatory authority but the required payload will depend mainly on the range of operations to be carried out. Many operations can be carried out including all or most of the following: production, limited storage, water injection, gas lift or reinjection, pigging or through flowline, full workover, drilling, subsea system maintenance. Concrete is often used in construction which is ideally suited to resist the hydrostatic compressive forces and ship impact forces without deterioration in a

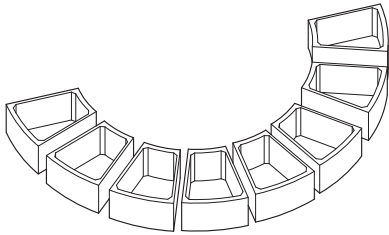

MODULE AGGREGATION

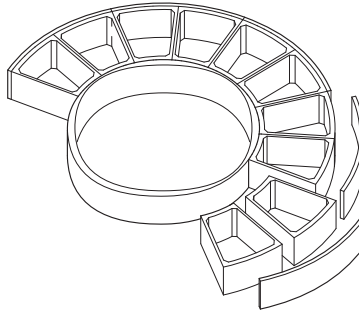

PRE-CAST PANELS INTERIOR/EXTERIOR

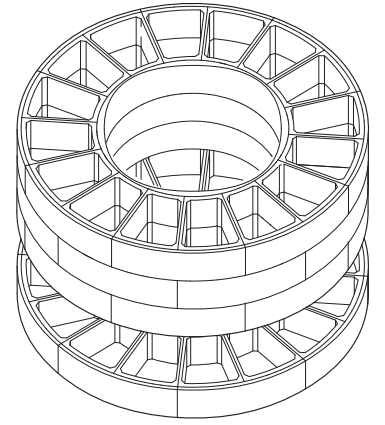

RINGS STACKED STAGGARED

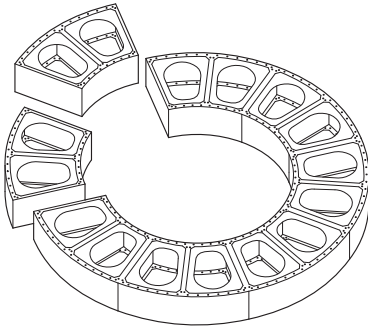

MODULE AGGREGATION

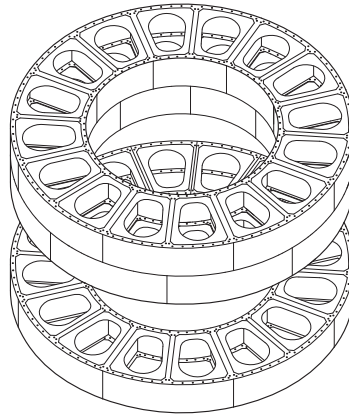

RINGS STACKED STAGGARED

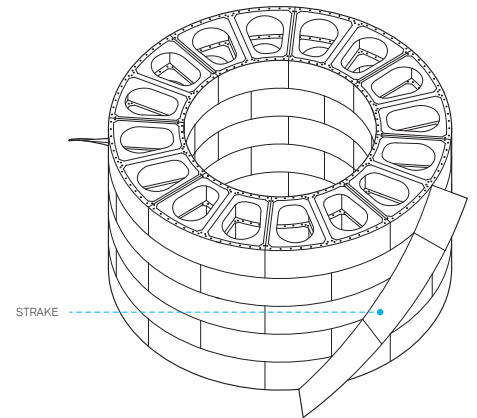

STRAKES ADDED FOR STABILITY
(TYP. MACRO MODULE: 5 RINGS)

severe marine environment.²

The construction of the SPAR platform that is utilized in the Dead Zone architectural intervention would follow the drawings above. The first choice would be to select an appropriate interior geometry shown on the far right, whether it be circular, hexagonal with filleted edges, or square depending on the structure that will be inserted. However, the base is crucial when determining the depth of the context and the ratio from buoyancy to ballast. These modules can either be pre-cast concrete modules or steel truss modules. The steel truss modules would certainly be lighter or much more malleable in terms of main-

tenance. In addition, each module would serve one of two functions: buoyancy, ballast. Some may have permanent pulverized iron ore for a more secure structure. The drawings on the right represent the assembly process or accumulation of the modules before the strake is added

1. Maclachlan
2. Goodfellow Associates

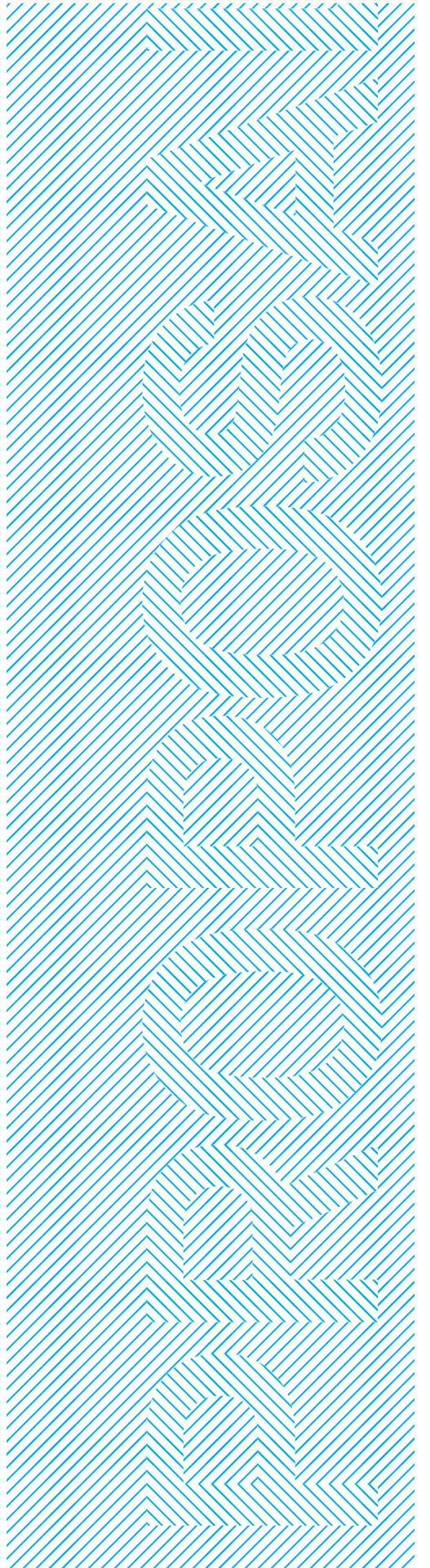

Proposal

As mentioned before in the abstract, Maritime institutes have been attempting to resolve this issue with larger infrastructural landscape interventions including: artificial wet lands, reefs, oyster beds, diminishing fertilizer use, etc. However, Completely diminishing dead zones, especially the systems that pose the most threat, would involve incredible global engineering and cultural shifts. This proposal is not attempting to completely resolve the issue of hypoxic systems. It accepts the inexhaustible supply of rich nutrients as a critical gesture of visibility catering to the affects of the social political agenda inland. Meaning, this reoccurring issue of hypoxia would be utilized as an opportunity to deploy a network of interventions offering a platform or tangible interface for maritime institutes to utilize as a catalyst to generate soft boundaries of oxygenated waters for animal life attraction, harvesting algae, as well as progressing data throughout the Louisiana-Texas shelf for the understanding of dead zones.

(Below is the time-based sequence for the architecture to adapt to the context)







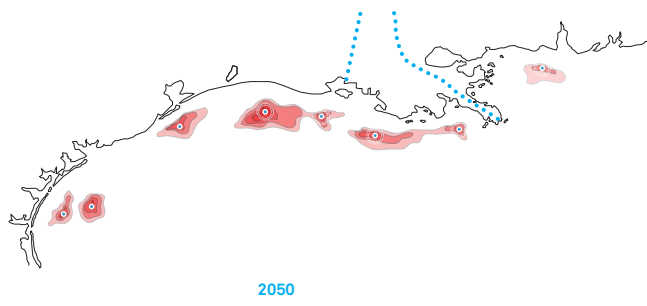
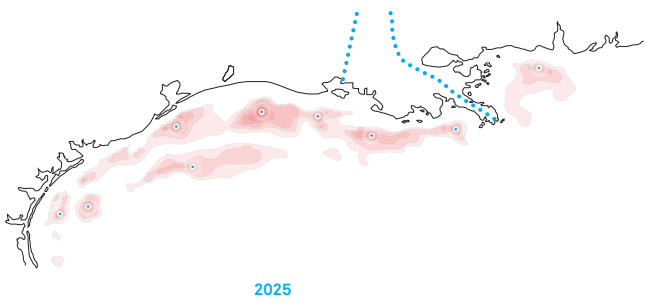
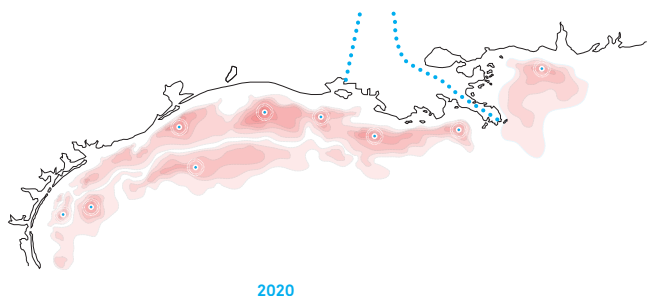
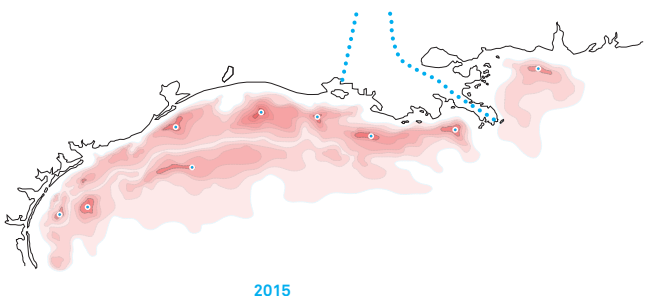
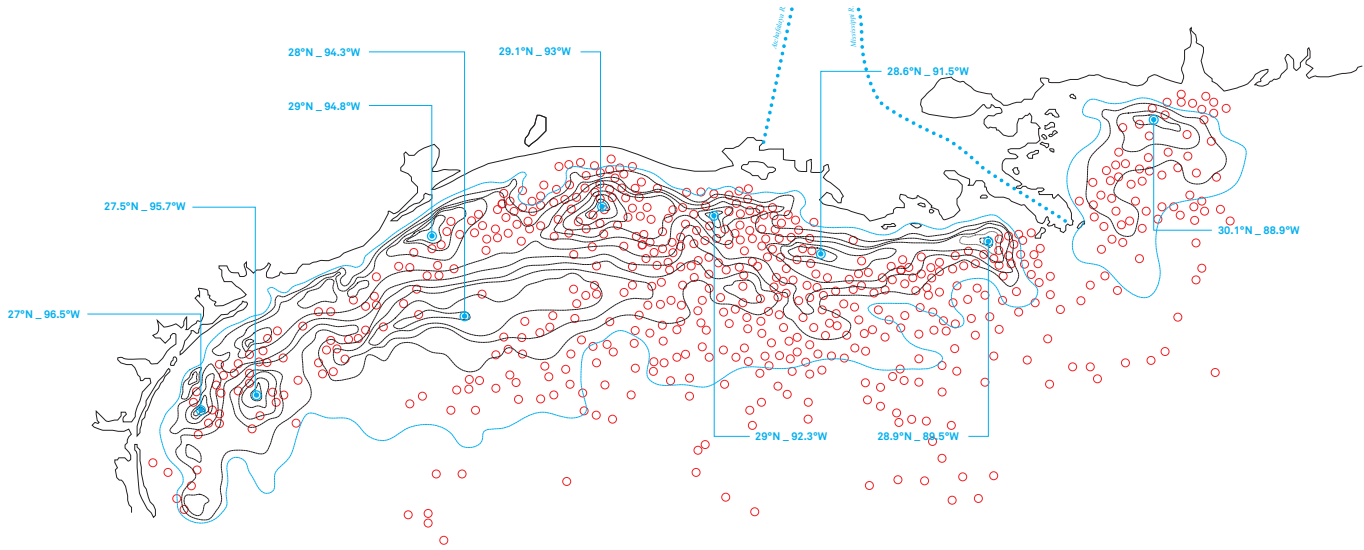

-- Hypoxia Networked Infrastructures --

Here we revisit the network infrastructural system of hypoxic zones. The top map is the overlaid data collected by the NOAA which reveals the pinpoint areas of hypoxia severity. These nodes could potentially be the initial sites for intervention. This proposal implements a time-based adaptive architecture offering several modalities for mitigation of hypoxia including: algae cultivation, algae harvesting, and the aeration oxygenated waters. For the months of hypoxia, the immediate approach would be harvesting algae blooms within reoc-

curing areas. The act of collecting hypoxia causing algae could potentially reduce dead zones by 5%.¹ Yes, this is very insignificant in the global aspect; however, this would be coupled with other modalities of mitigation. In addition, this is the only attempt for remediation requiring occupation which demands an architectural intervention. Meaning, the occupation for algae cultivation and collection as well as aeration. The architecture acts as the beacon or visual connection to this drastically increasing issue not only in the Gulf of Mexico, but in a Global understanding as well. Over the years and into 2050, the hypoxic systems could reduced signifi-

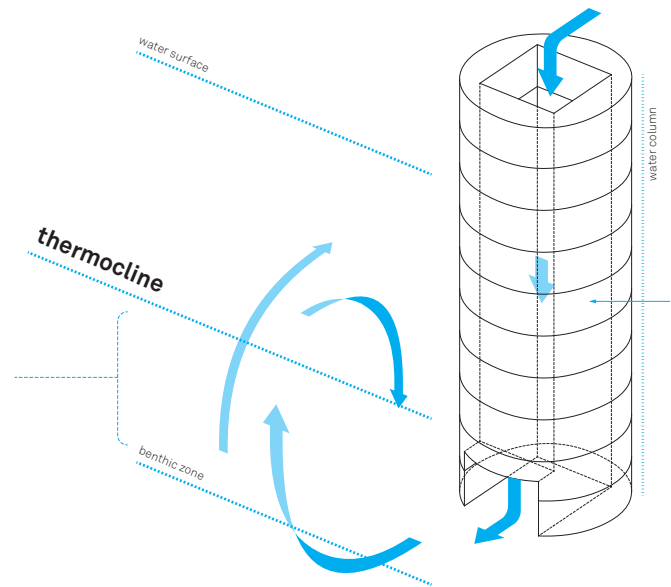
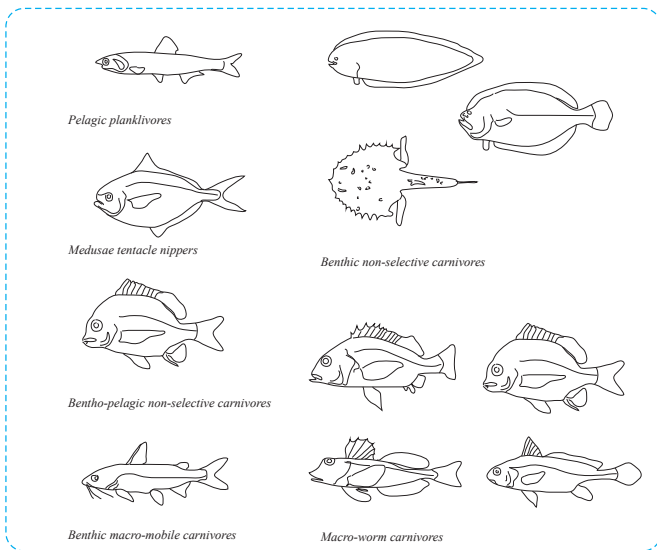
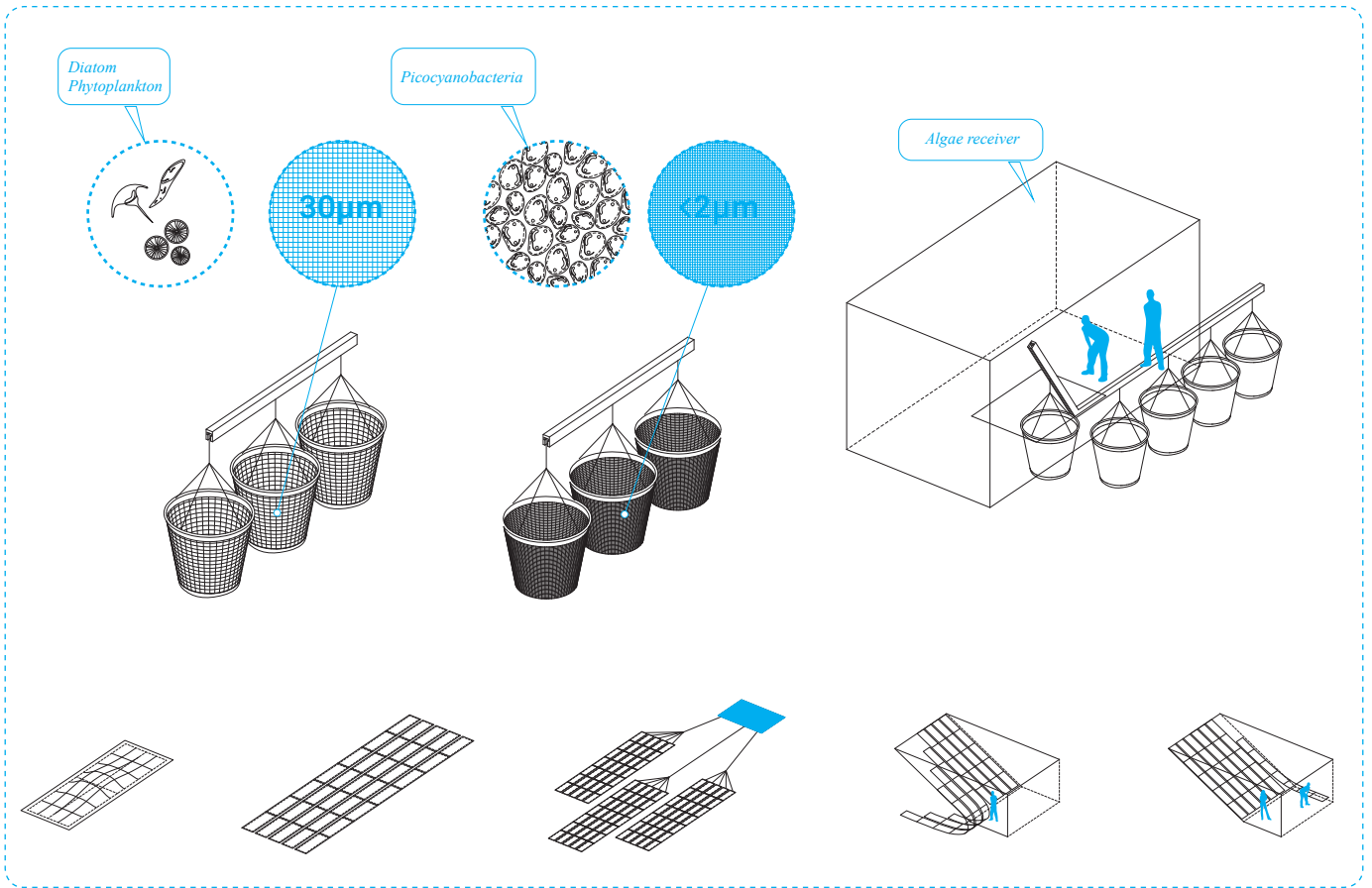

cantly with effort within all modalities and possibly concentrated for benefits in energy movements.

Mitigation

Looking at the communities of algae growth in the gulf, one can see the hypoxia causing algae, called the cyanobacteria, begins to dominate the area even into the month of October. However, there is the opportunity to harvest diatoms and other phytoplankton during the remaining seasons. As the algae dies, another mode of mitigation utilizes an architecture encompassing the entirety of the water column

or what is known as a spar deriving from offshore petroleum structures, which would activate an aeration system or water fall attempting to break the thermocline boundary through natural convection bringing higher oxygen levels back to the benthic layer. In addition, there is potential to take advantage of this process, gravity could be an opportunity for collecting the remaining algae on the surface. The architecture above would

1. Chih-Ting Kuo, 2010

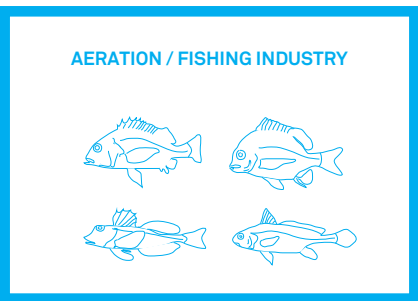
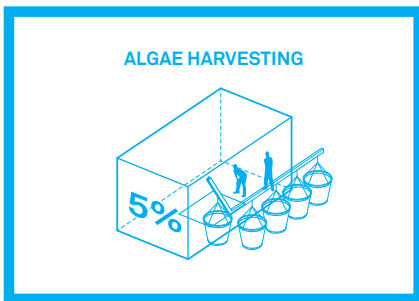
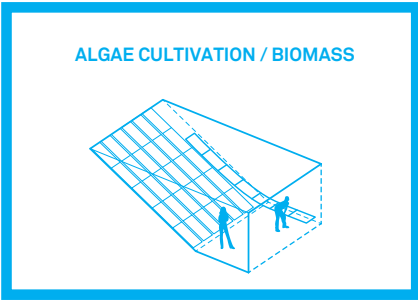
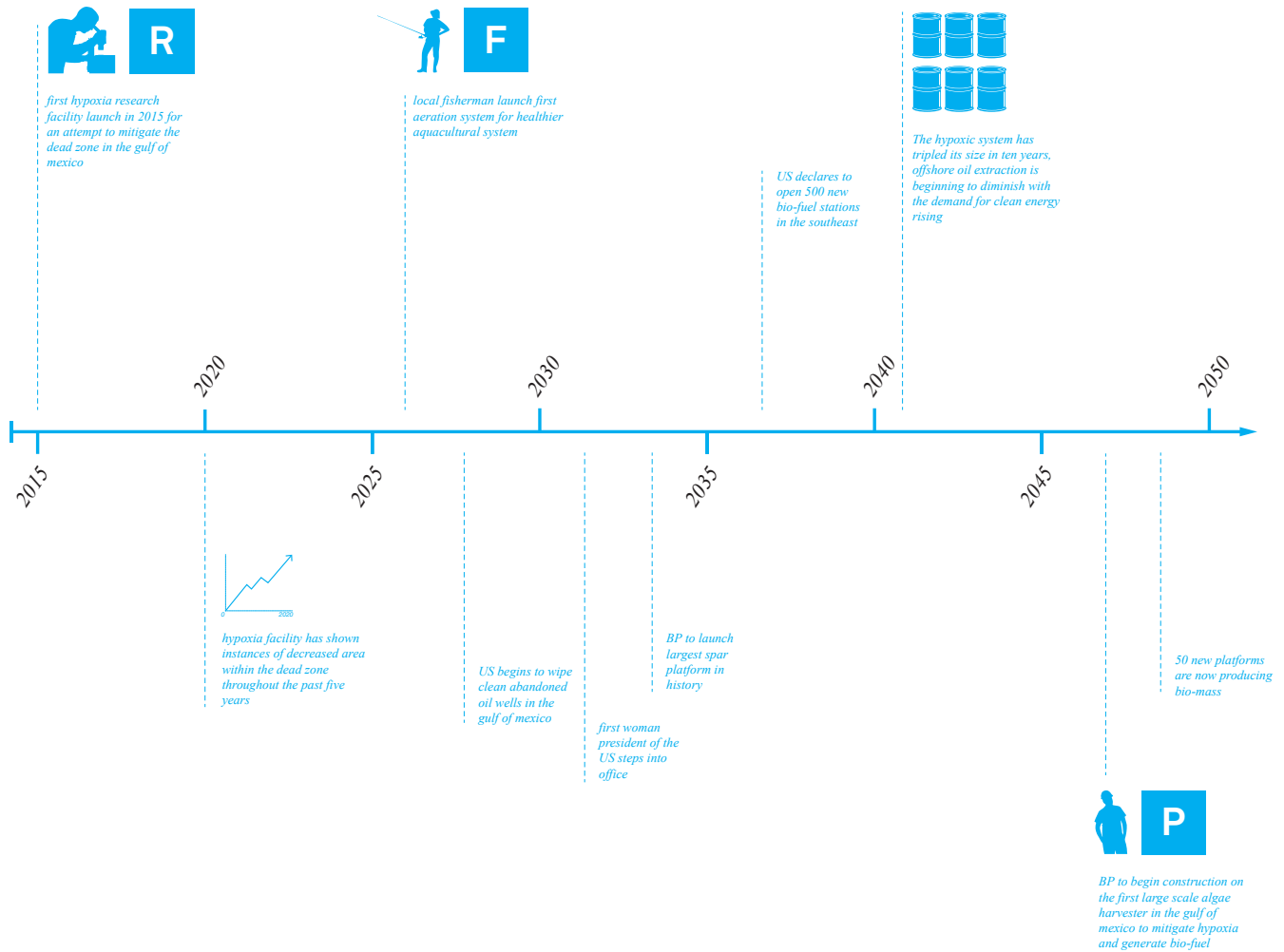

be the retriever for hypoxia researchers. The combination of these actions would be extremely beneficial to the aquatic life within the area as well as the potential fishing industry. For the months of October through April, the architecture would offer a facility for cultivation systems at different salinity levels, temperatures, and lighting conditions. Taking advantage of the buoyant context, the cultivation systems would be a deployable field where algae can begin to photosynthesize. In addition, harvesting algae can also occur during these months. One would collect diatoms and phytoplankton for experimentation as opposed to hypoxia causing algae.

In the end, Maritime institutes would have the opportunity to work within the context of hypoxic systems throughout the year, potentially diminishing the area of dead zones through algae harvesting and cultivation for experimental use or a new market in bio-mass, and aeration could possibly enhance the global fishing industry, but more importantly the life cycles within the marine environment. The structure would be assembled using the techniques of the spar offshore petroleum platform. Referring to the drawings on the right, the spar would essentially act as the base or chassis for the tool head to be inserted. Each "tool" or unit for occupation would

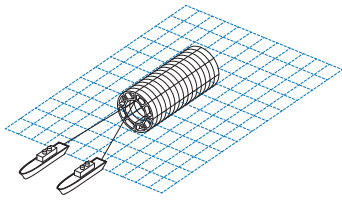

TOW TO SITE

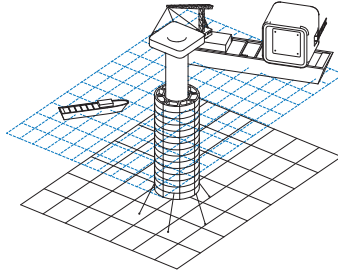

INSERT BASE

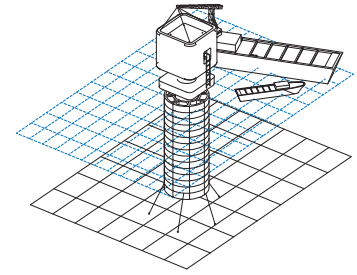

ASSEMBLE HULL

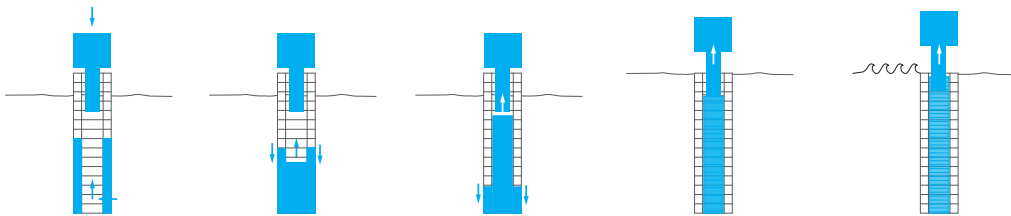
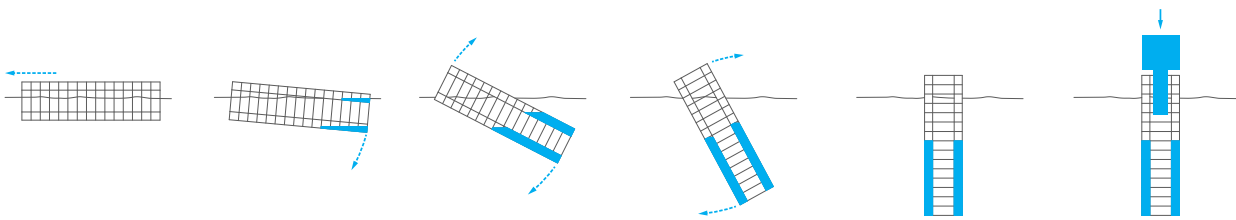
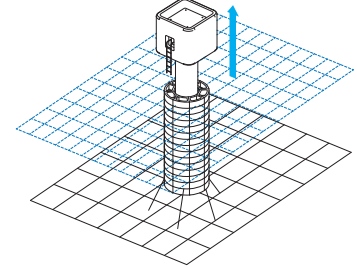
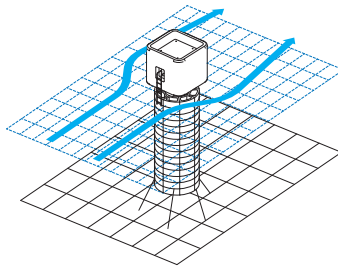
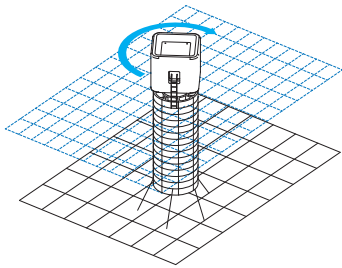

provide different necessities of accommodation according to the demographic. These units could potentially be for either researchers experimenting for a few months, fisherman utilizing the structure for aquaculture, or production corporations attempting to make transitions in energy.

Toward 2050

Ten years from now, these hypoxic satellites begins to show decreased area within the dead zone and new characters begin to arrive in the narrative. Local fisherman launch the first aeration system

community for a healthier aquaculture system with soft boundaries of oxygenated water. Looking down the line 5 years later, the pirate bay gets a hold of one these and uses it for a secure network of internet laundering within a self sustaining algae harvesting architecture. In 2050, BP begins construction on the first large scale algae harvester in the gulf of mexico to mitigate hypoxia as a front and to generate bio-fuel.

(far left: timeline of hypoxic condition; top right: assembly process for the fisherman's platform; bottom right: buoyancy diagrams)

{ 2015 }



PLATFORM TYPE:
**RESEARCH & DEVELOPMENT
IN HYPOXIA**

SOUTHWEST PASSAGE

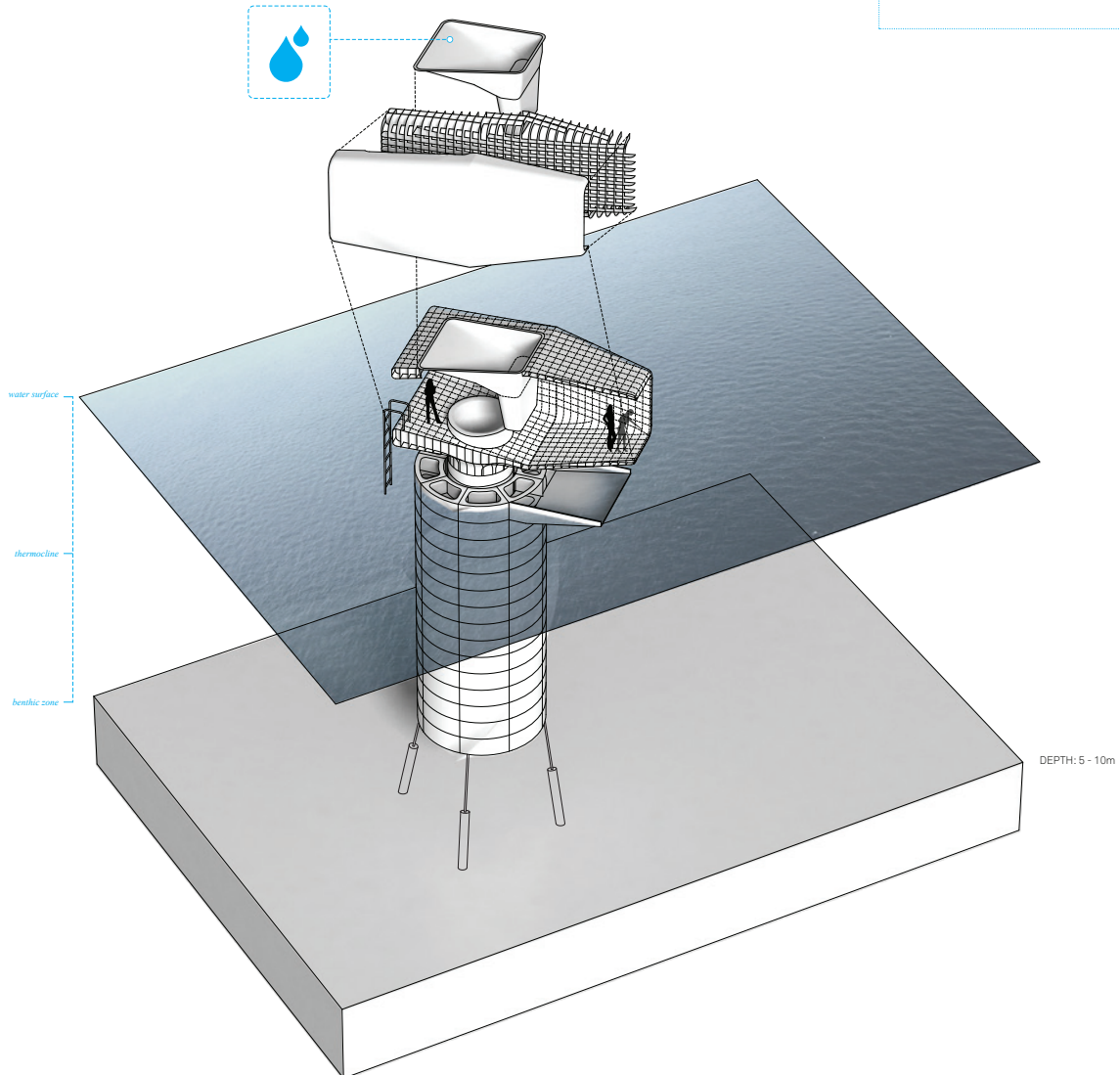
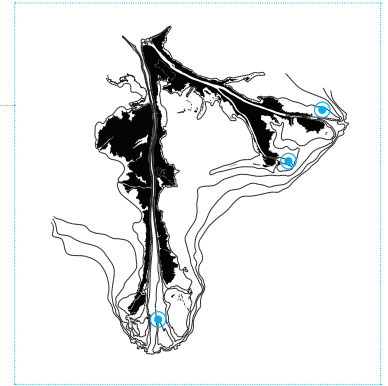

-- Research and Development Platform --

The location of this particular platform would initially be implemented within the major hypoxic systems of the delta outlets. Each platform would mainly be for maritime institutes to expand upon hypoxia within the actual context. This platform would offer all the necessary field equipment for R & D including: sonar, doppler, centrifuge, accommodation for visitors, plankton nets, and trollies.

Axonometric:

Equipped with secured ballasted spar belly, fresh water vessel for

cleaning equipment and accommodation. *(Interior seen on pg. 57)*

Section A:

During the phase of algae cultivation within the months of september through April.

Section B:

The algae harvesting phase during the months of May through September; aeration of water column

Section C: *(perspective on pg. 49)*

Here the platform is in defense mode utilizing the ballast and buoyancy system the hull can avoid hostile seas.

section: A

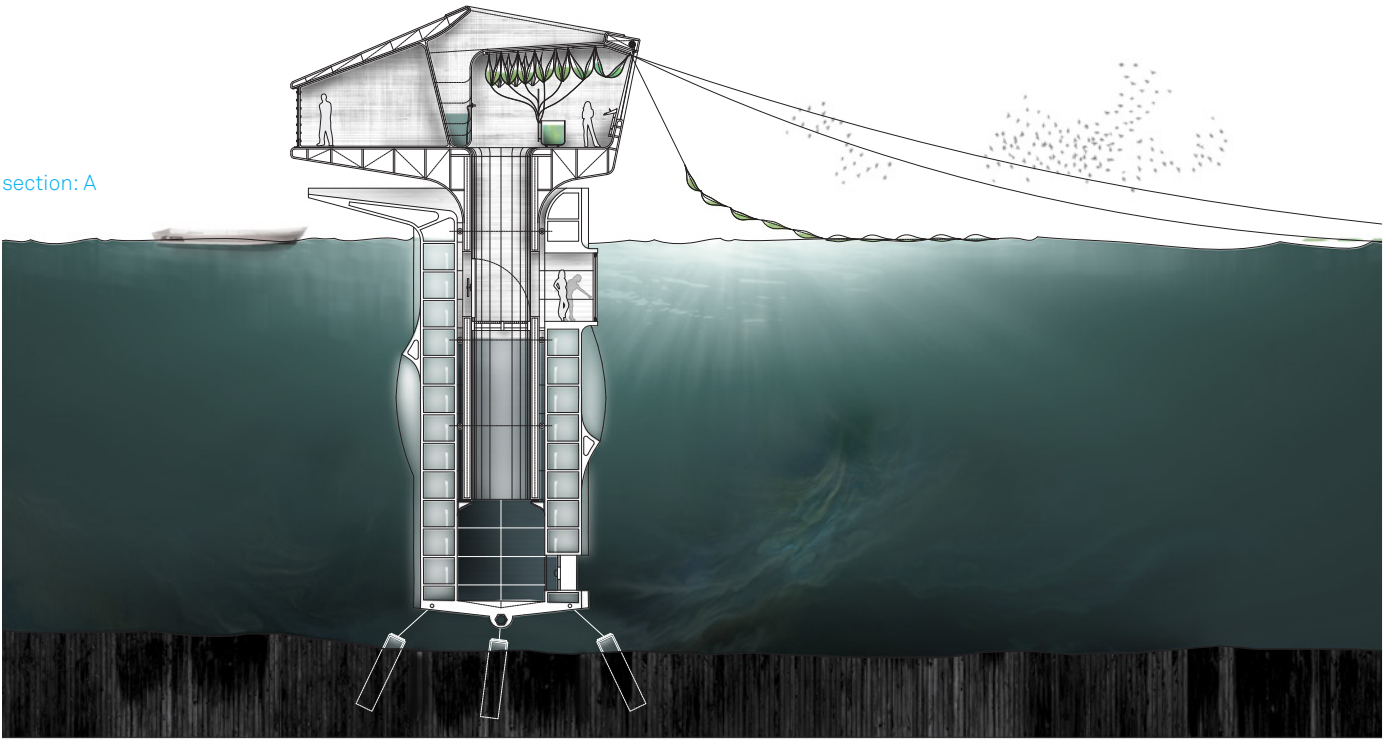

section: B

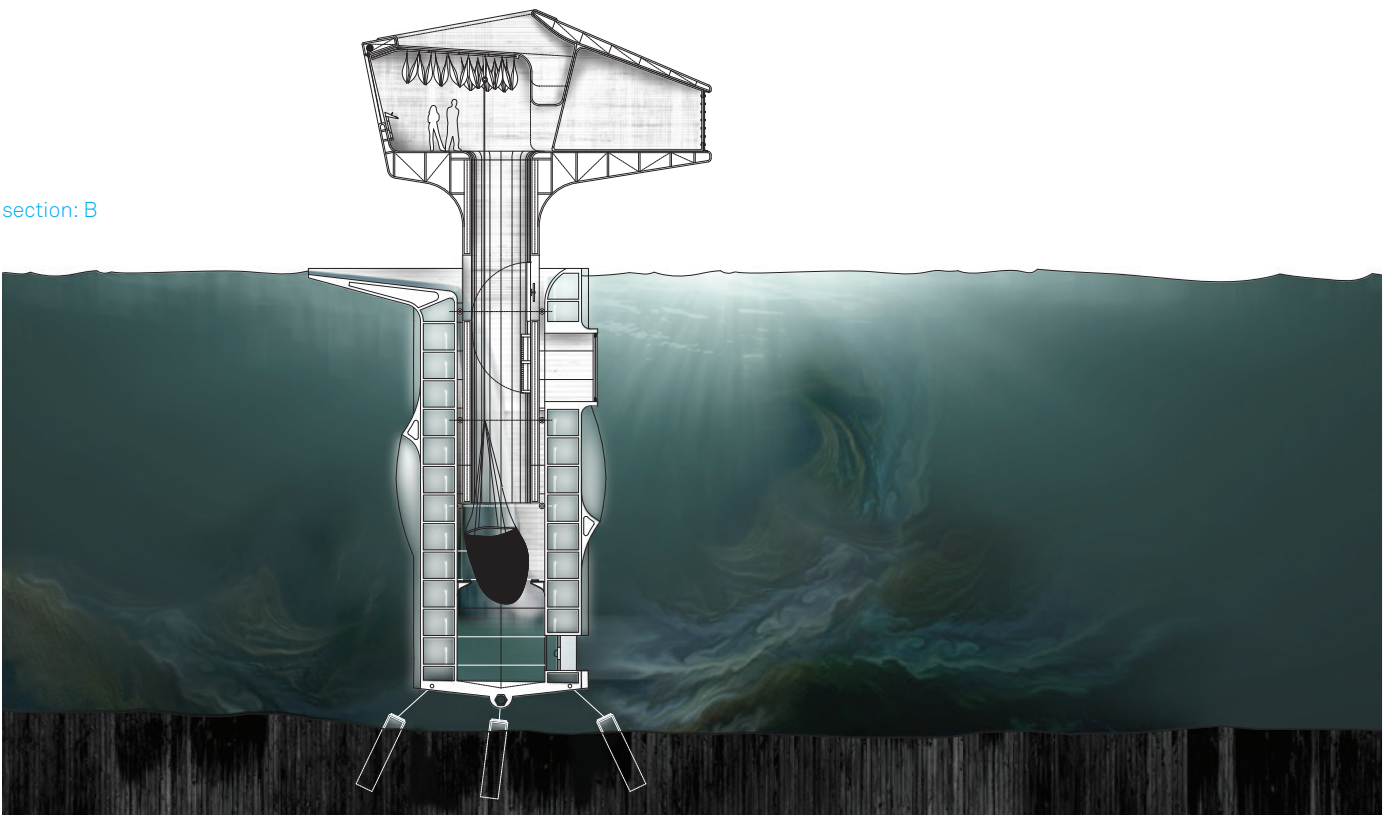

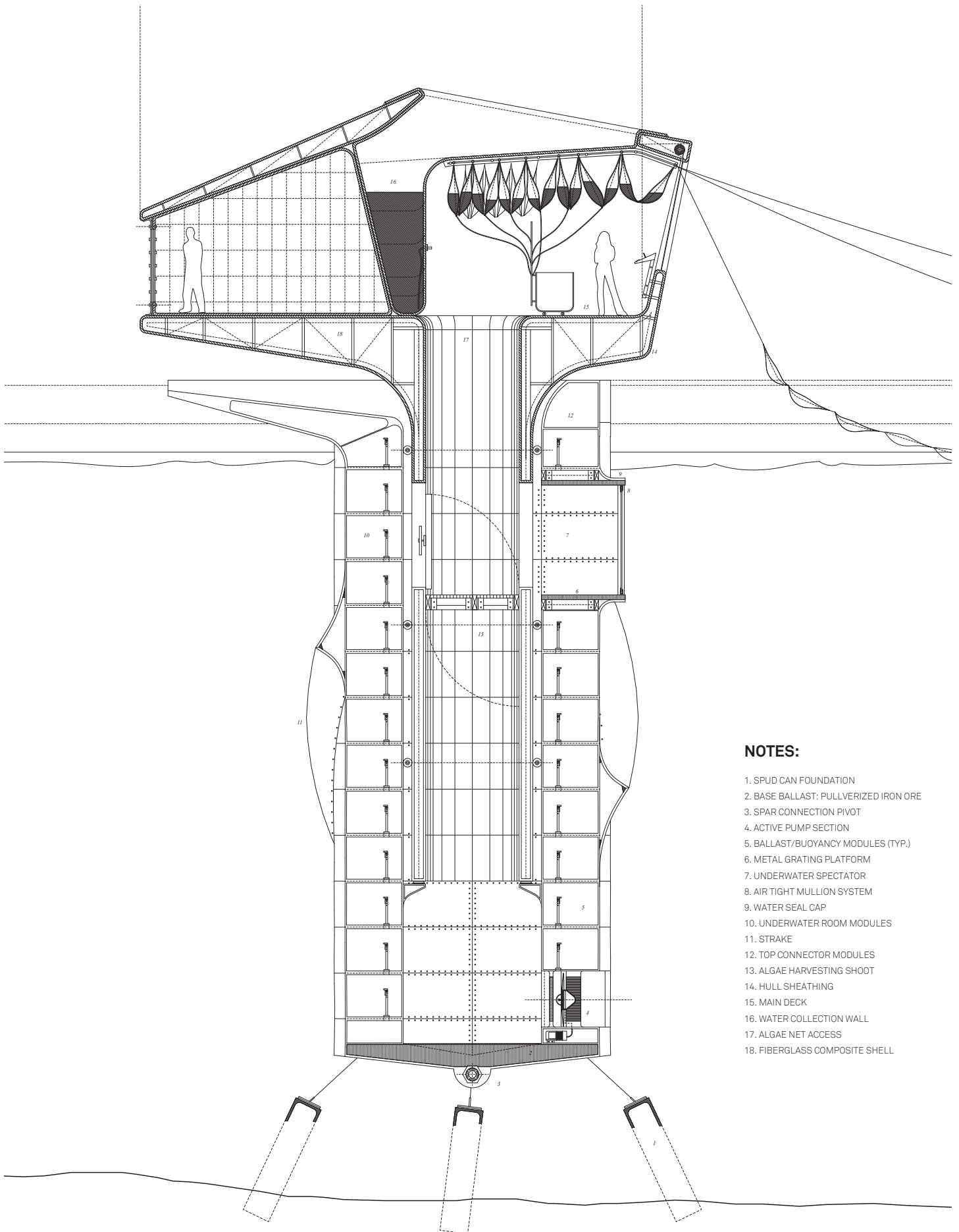

NOTES:

1. SPUD CAN FOUNDATION
2. BASE BALLAST: PULLVERIZED IRON ORE
3. SPAR CONNECTION PIVOT
4. ACTIVE PUMP SECTION
5. BALLAST/BUOYANCY MODULES (TYP.)
6. METAL GRATING PLATFORM
7. UNDERWATER SPECTATOR
8. AIR TIGHT MULLION SYSTEM
9. WATER SEAL CAP
10. UNDERWATER ROOM MODULES
11. STRAKE
12. TOP CONNECTOR MODULES
13. ALGAE HARVESTING SHOOT
14. HULL SHEATHING
15. MAIN DECK
16. WATER COLLECTION WALL
17. ALGAE NET ACCESS
18. FIBERGLASS COMPOSITE SHELL

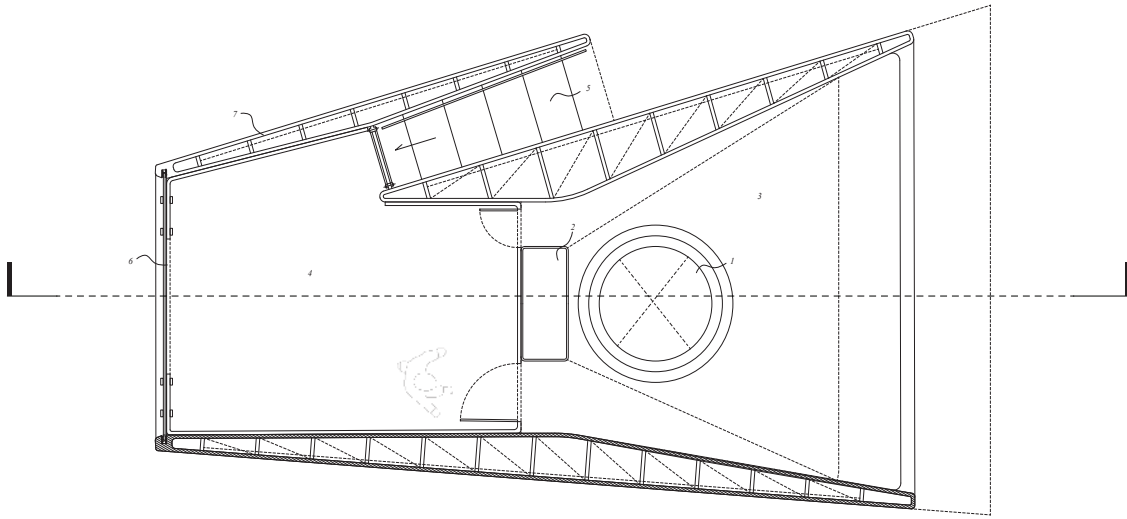

plan: main hull

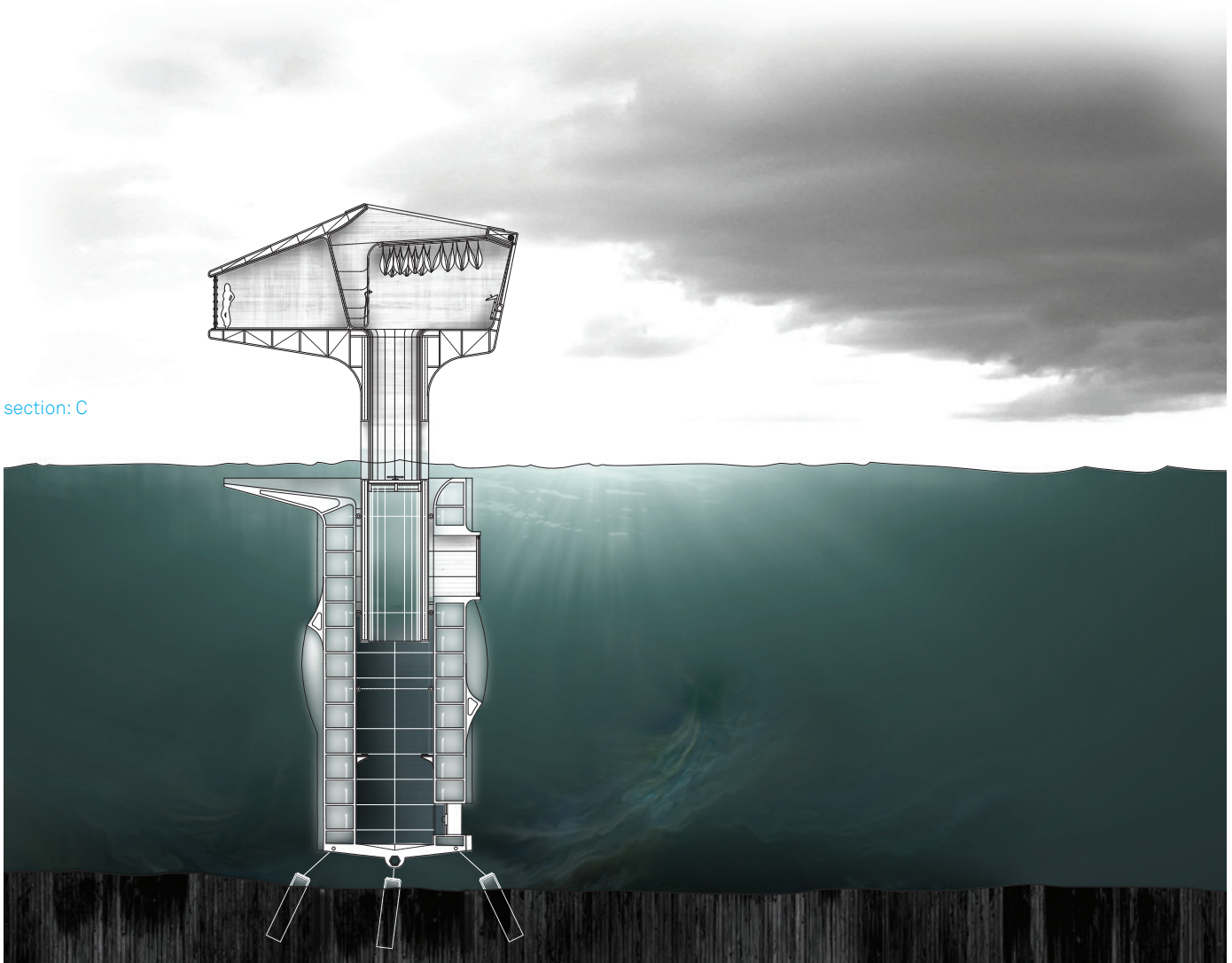

section: C





{ 2020 }

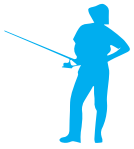

PLATFORM TYPE:
FISHING BUNGALOW

SOUTHWEST PASSAGE

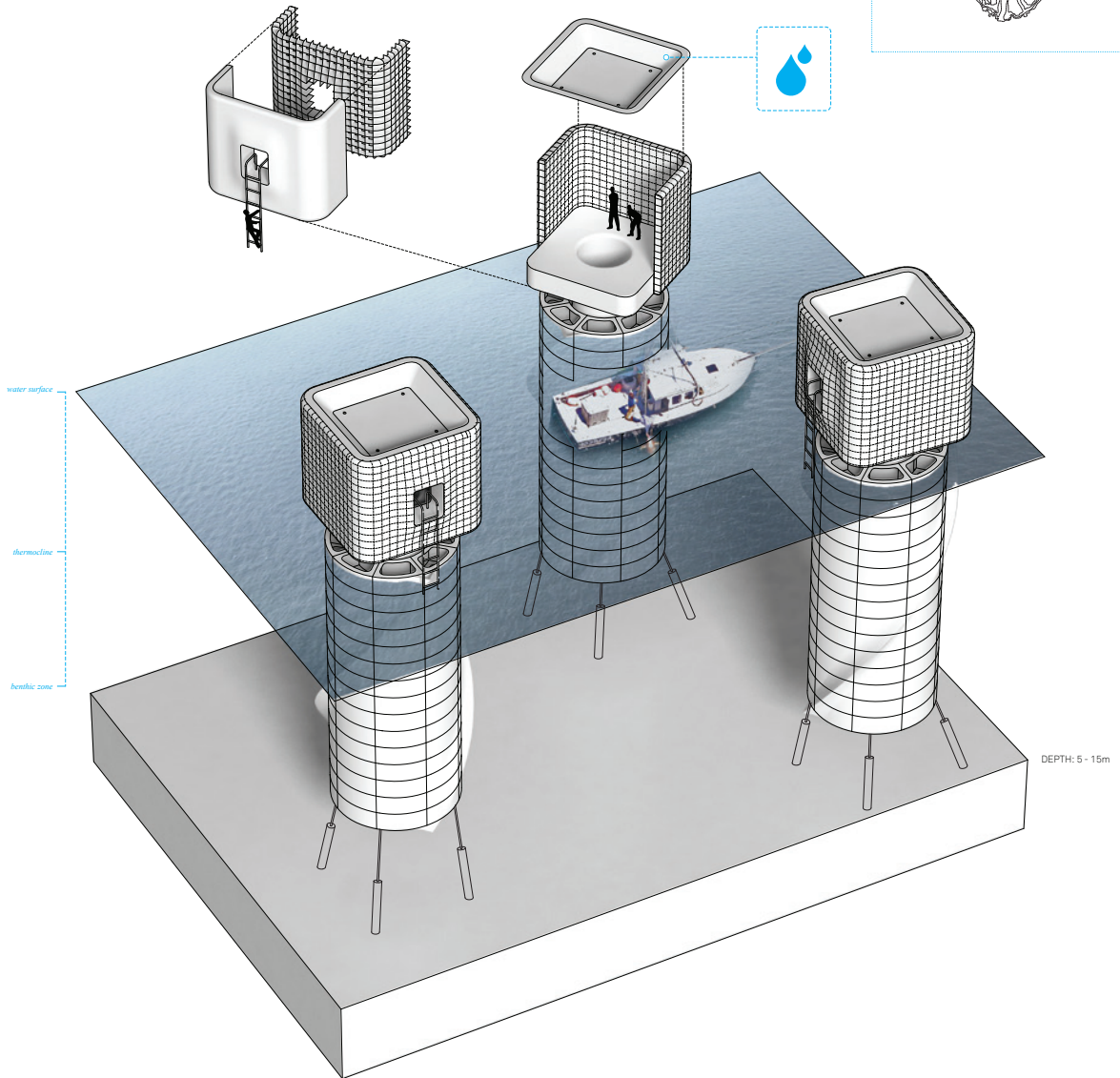
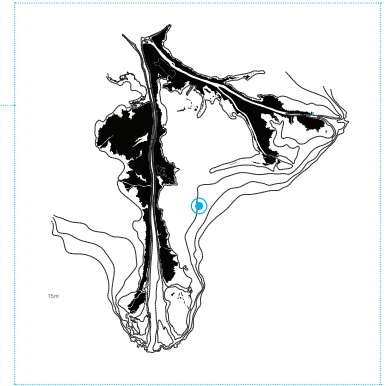

-- Fisherman's Platform --

The location of the fisherman's platform would be utilized within the major hypoxic systems of the inner Louisiana-Texas shelf . Within these areas a series of platforms may be clustered to create healthy waters. This buffer zone of would become a community for local fisherman to store equipment, and fish within a soft boundary of oxygenated waters.

Axonometric:

Each unit would be a robust structure offering storage space for the

fisherman with timeshares. Aeration would be automated.

Section A:

Here a barge is towing one of these units to the site of the hypoxic system

Section B:

With the spar in place, the fisherman unit would be assembled in two parts. Spar extension and hull.

Section C: (pg. 52 -53)

The unit is in place, and fisherman are beginning to create a natural aquaculture.

section: A

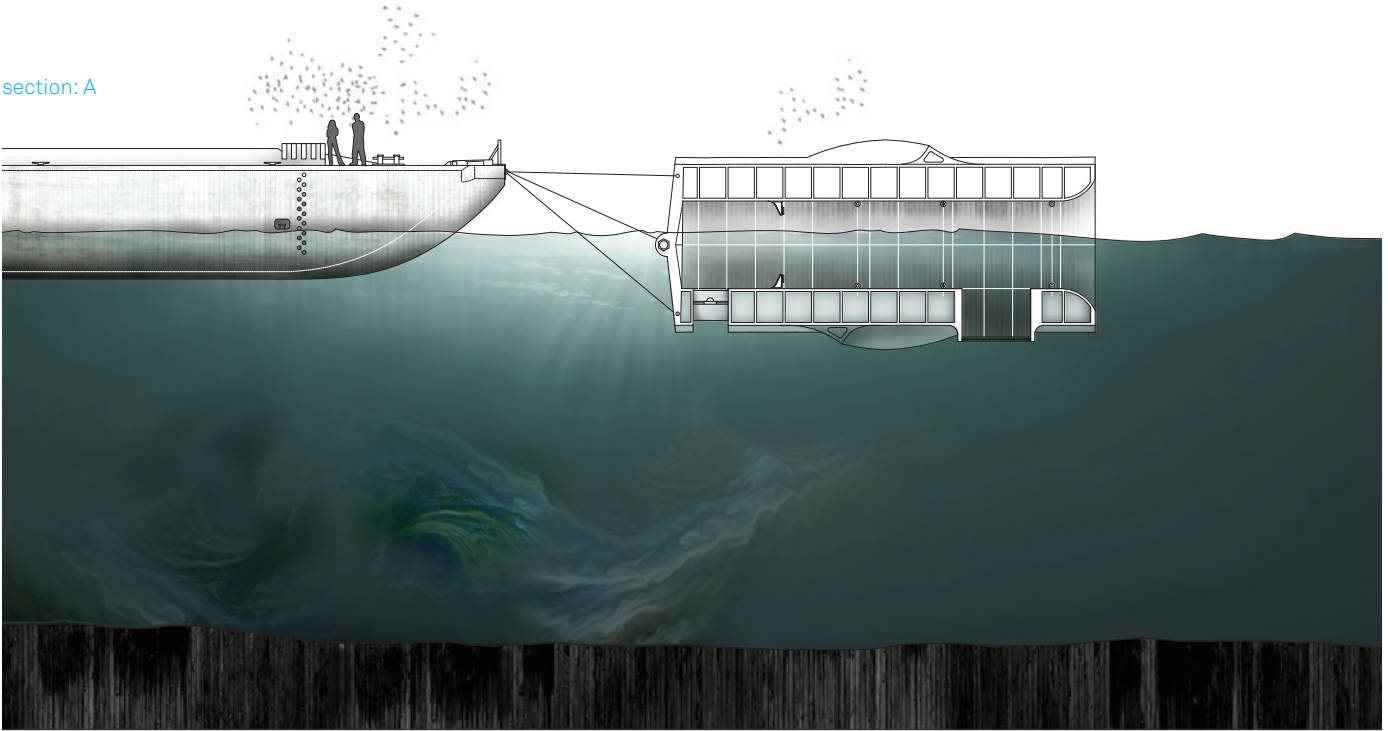

section: B

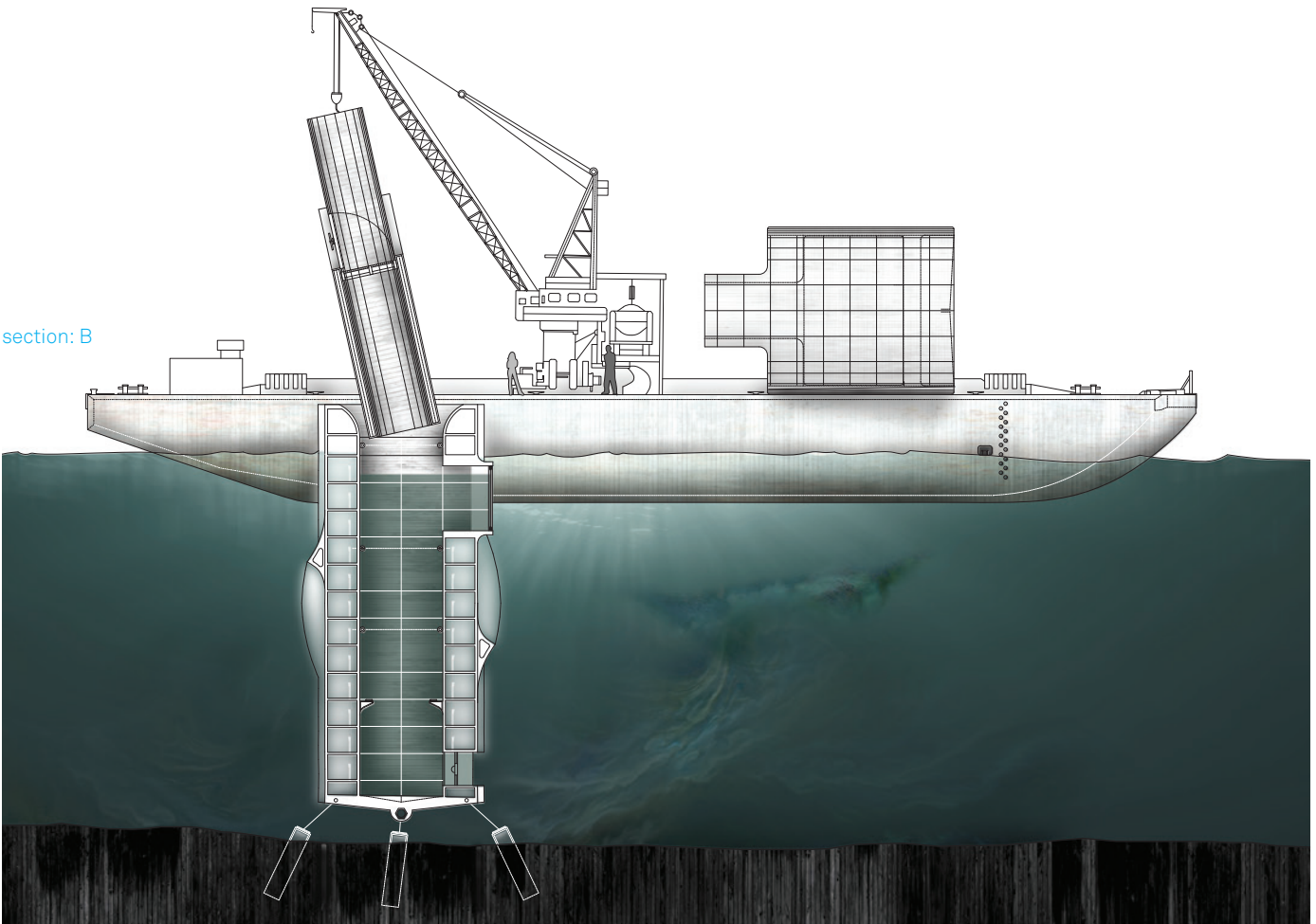

section: C

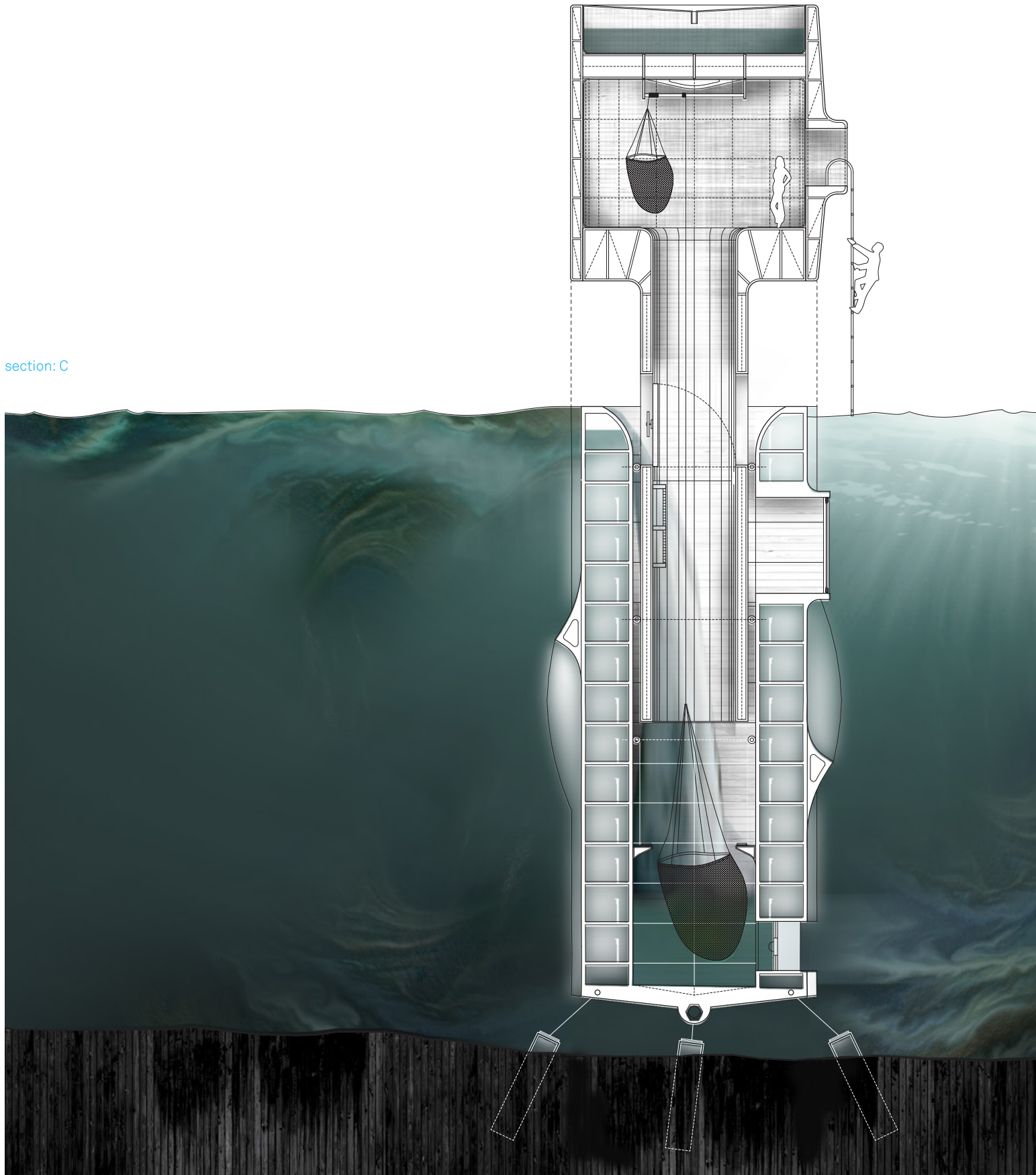

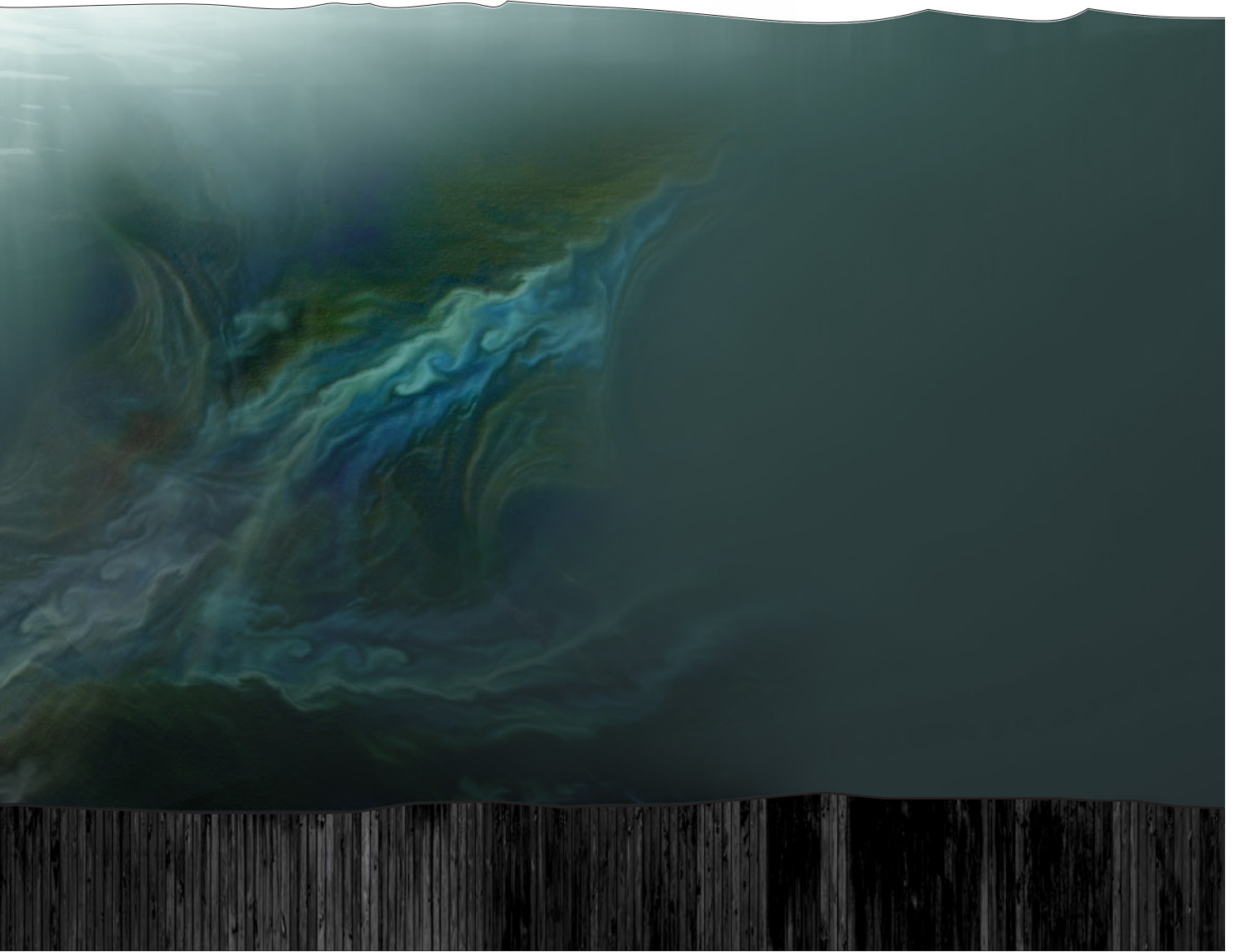



{ 2050 }



PLATFORM TYPE:
PRODUCTION

SOUTHWEST PASSAGE

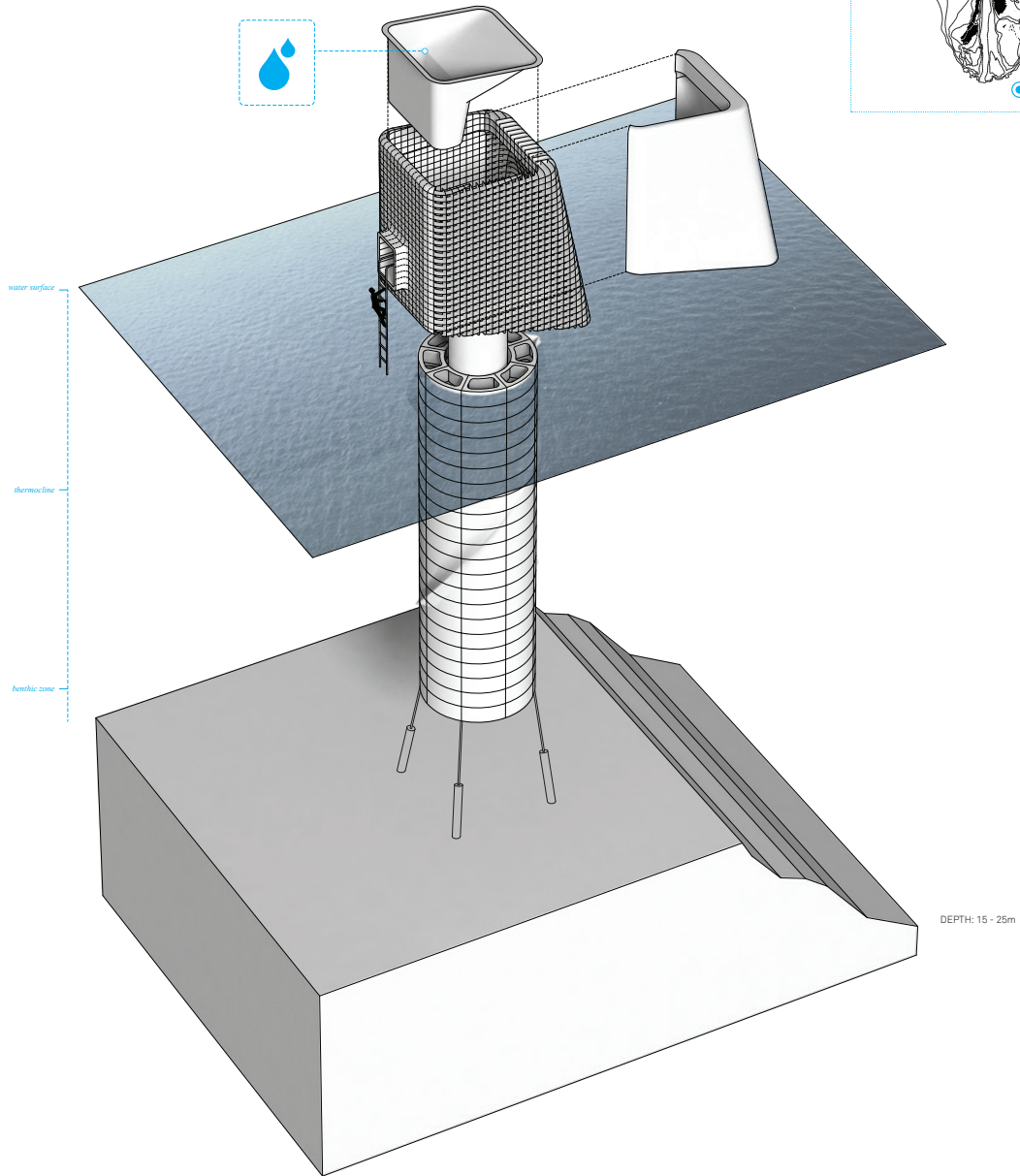
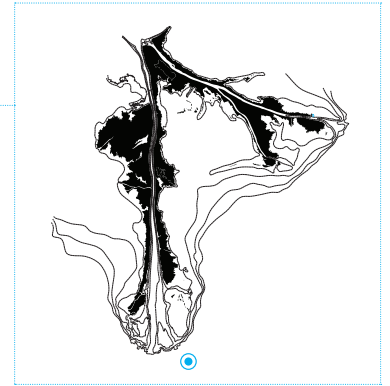

-- Production Platform --

The location of the production platform would be placed within the major hypoxic systems of the outer shelf. This platform would be used for larger operations of algae collection and cultivation taking on the assembly line of bio fuel production. also, tackling the issue of algae growing in different depths of water. maybe used by big oil super majors in the near future?

Equiped with secured ballasted spar belly, fresh water vessel for cleaning equipment and accomodation. The first floor is utilized for

harvesting the algae and aeration operations, while the second floor is used for cultivation and oil extraction.

Section:

Position on the very fringe of the outer shelf reaching depths up to 60 meters, the platform is currently harvesting algae where growth is occurring. In addition, the vast context of the ocean is utilized for an assembly-like production line for cultivating algae. Nutrients and algae are flowing upward toward the sunlight as a figure of power, while the architectural intervention attempts to halt death.

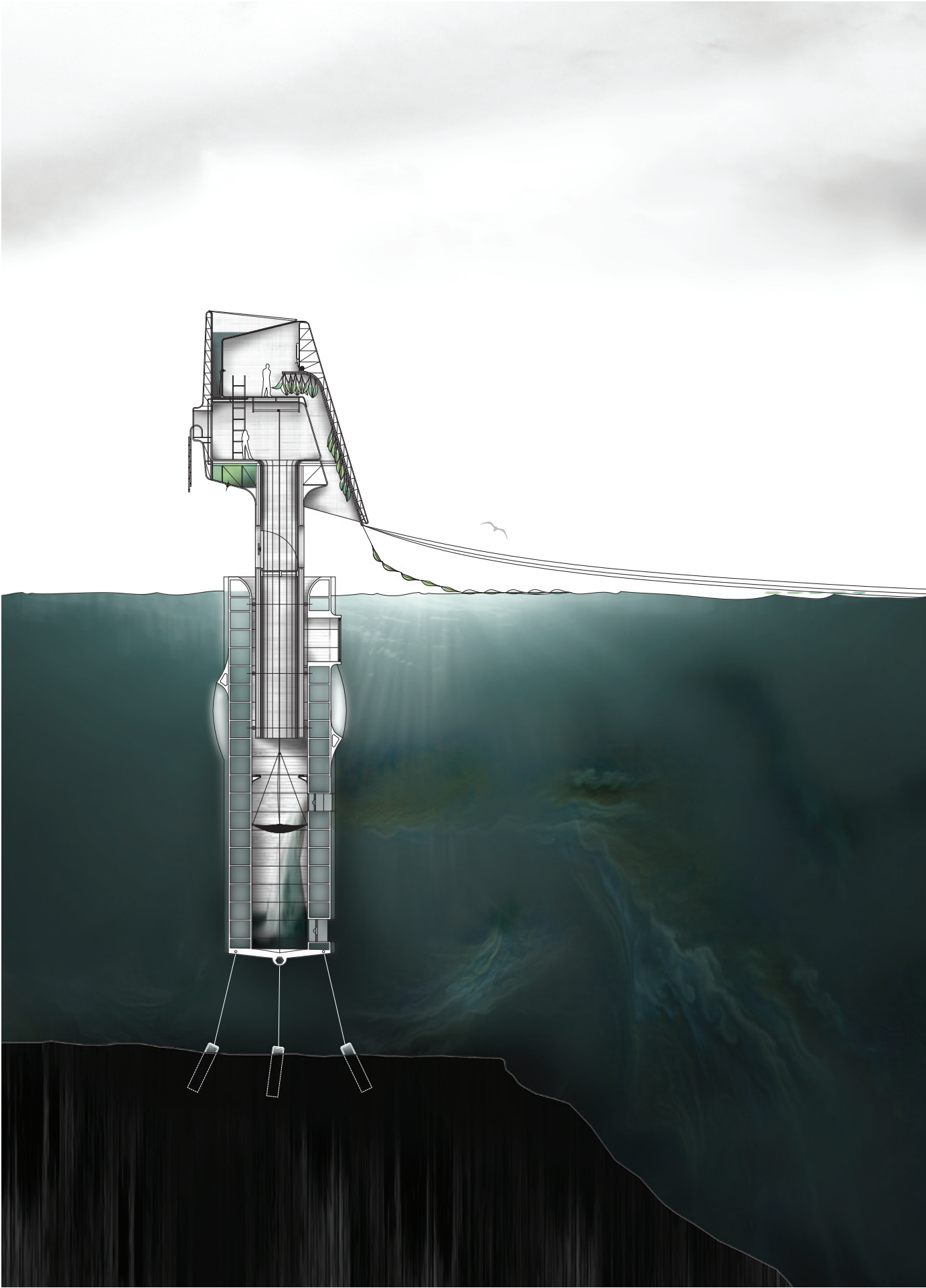

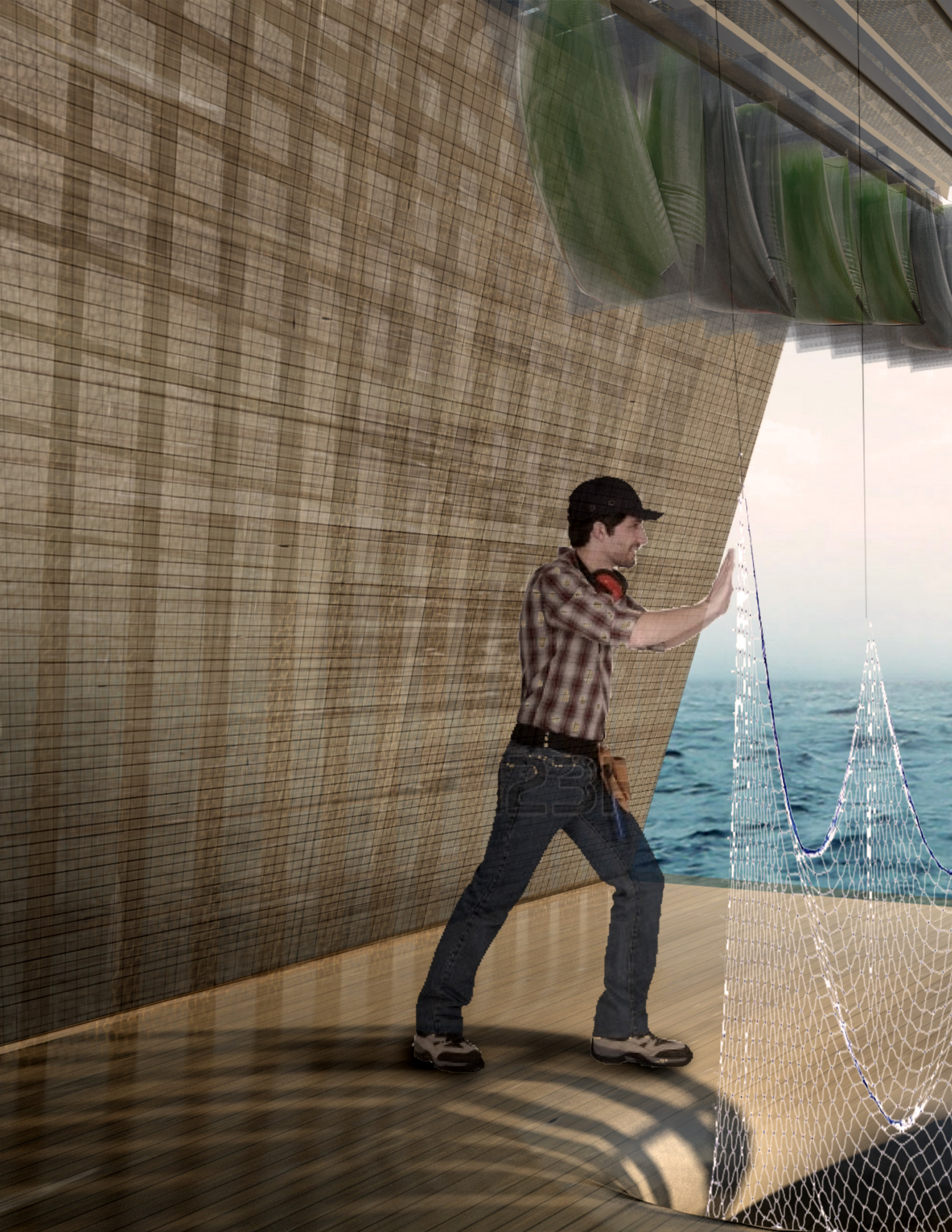



Research and Development Platform interior perspective

Here, two scientists, one peering into the distance at a steel truss petroleum platform, are reeling in the last of the algae cultivation quarantine packaging system while the season starts for aeration and harvesting for experimentation.

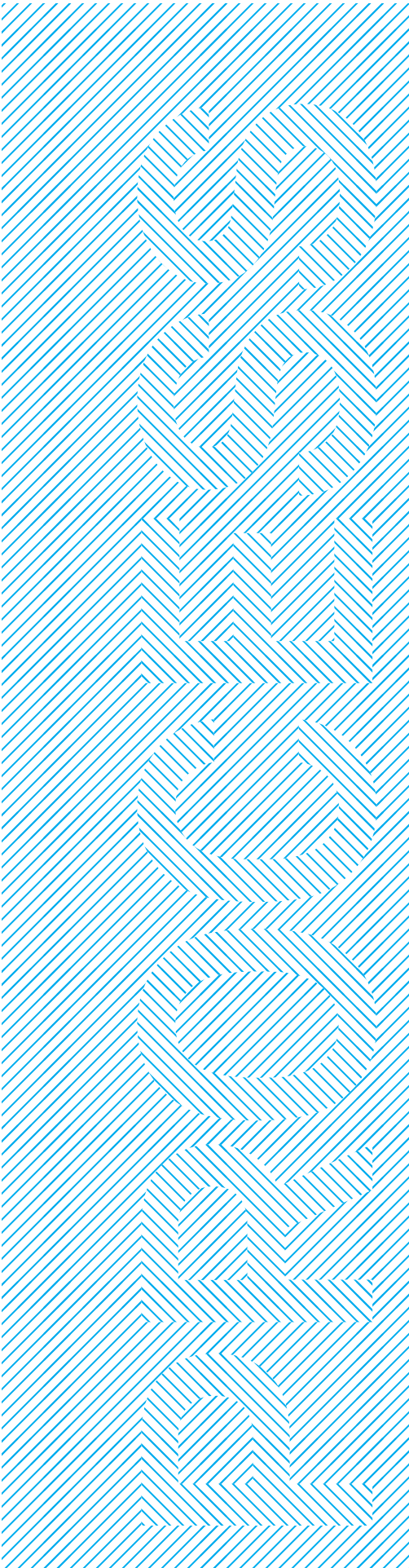

Process

This next section of the book explores the architectural process of the Dead Zone from start to finish excluding some work from thesis prep with Ana Miljacki. The process will range from iterations of form finding through physical modeling, sectional studies, and axonometrics.

pgs. 60 - 75 ----- **FinalModels**

pgs. 76 - 79 ----- **FirstReview**

pgs. 80 - 87 ----- **MidtermReview**

pgs. 88 - 95 ----- **PostMidterm**

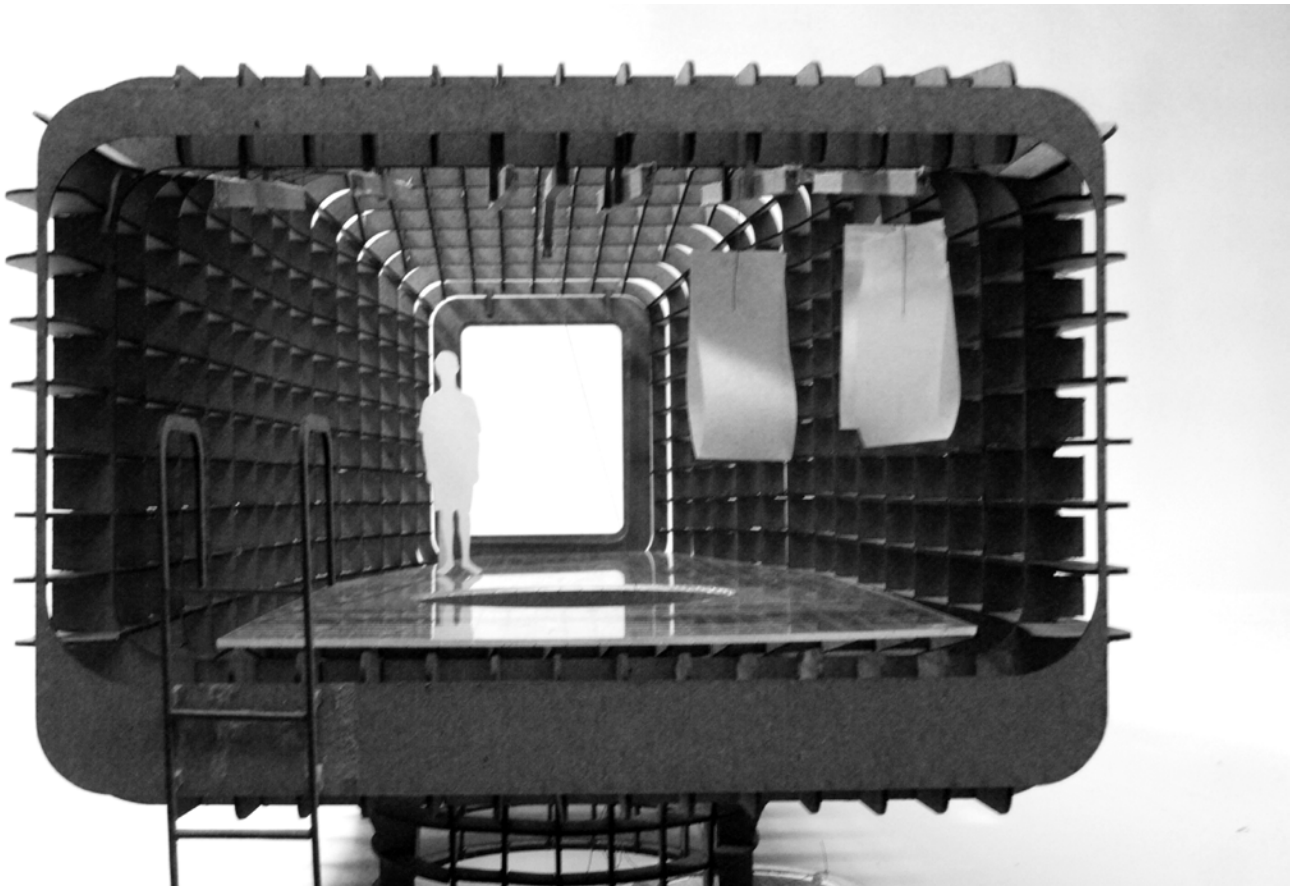

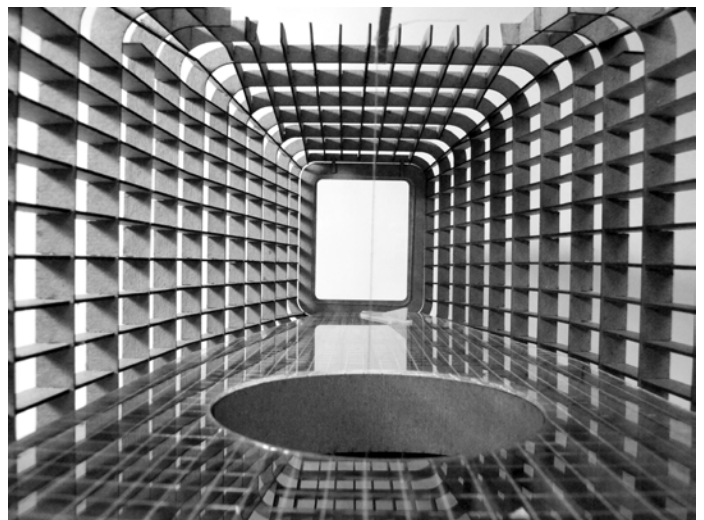
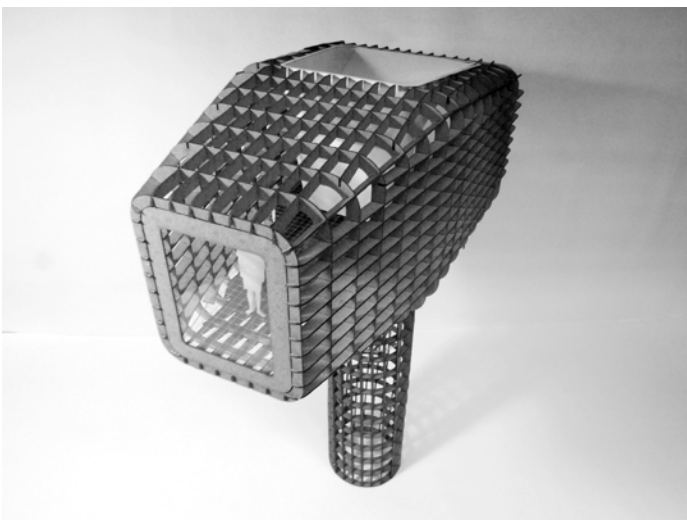
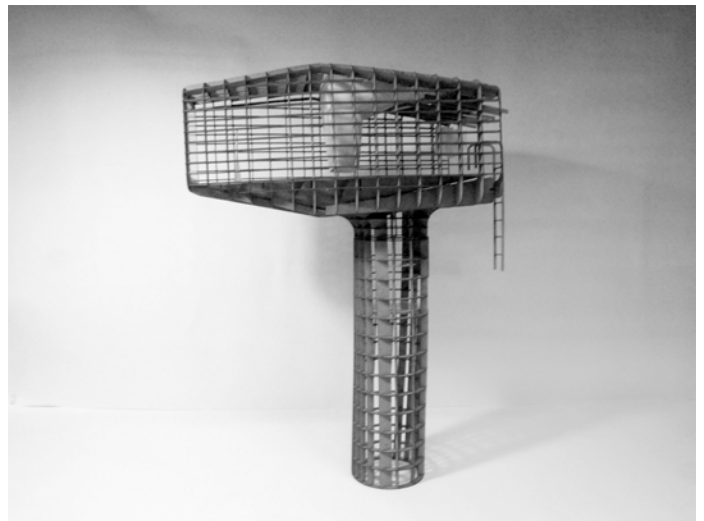
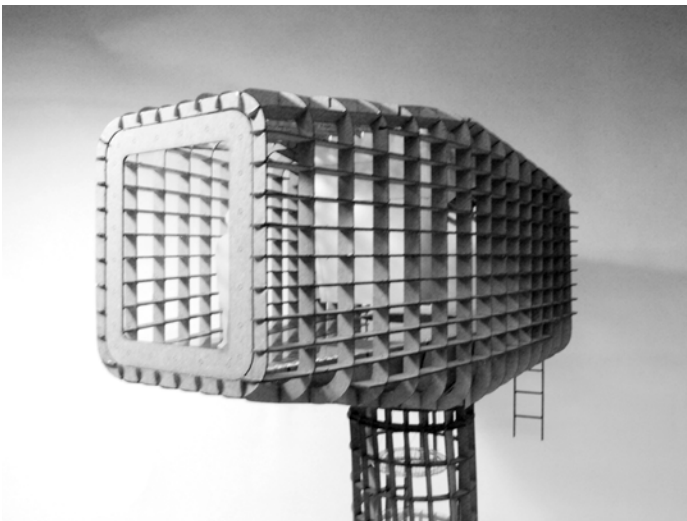
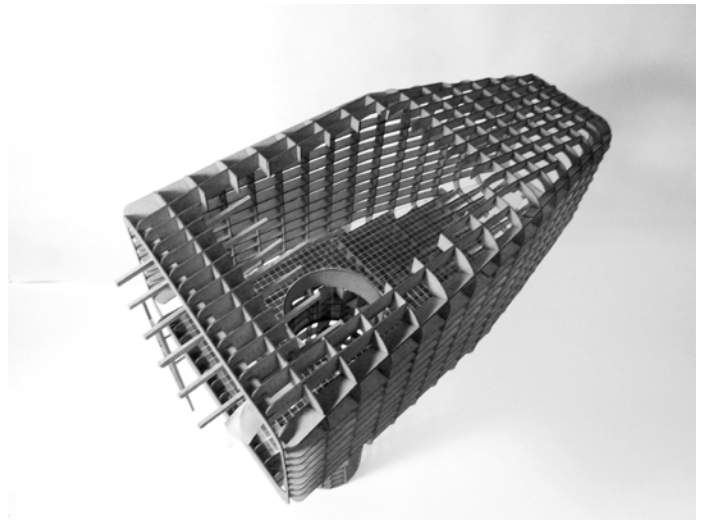
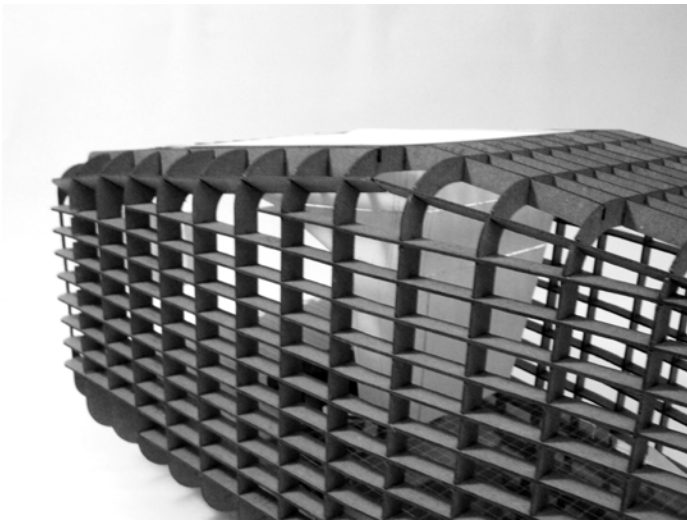
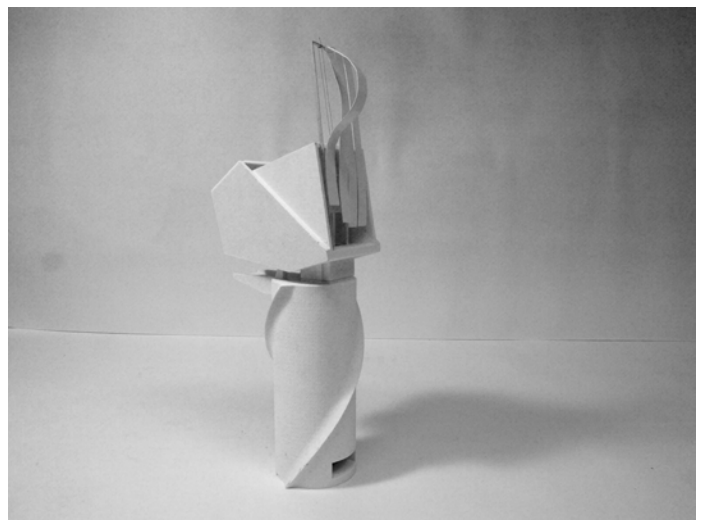
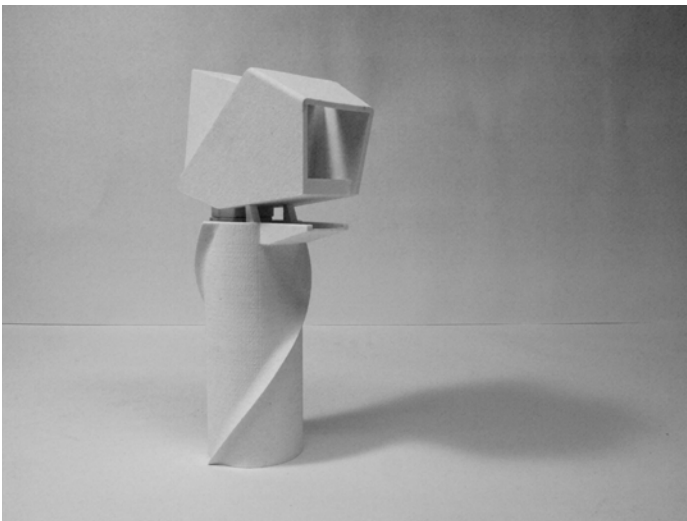
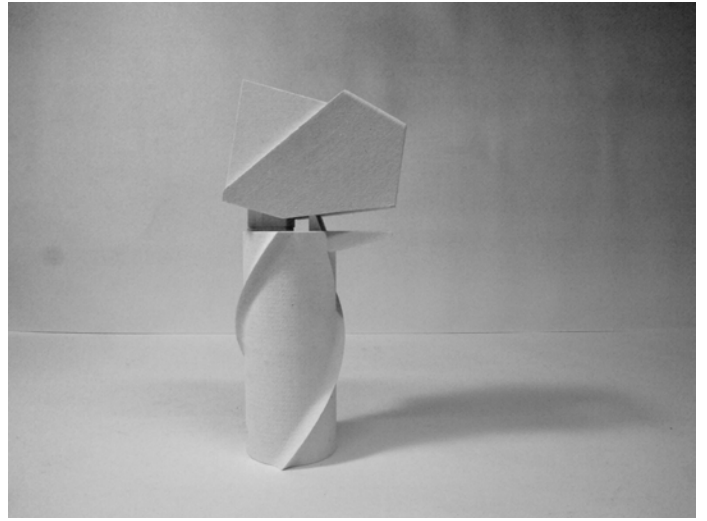
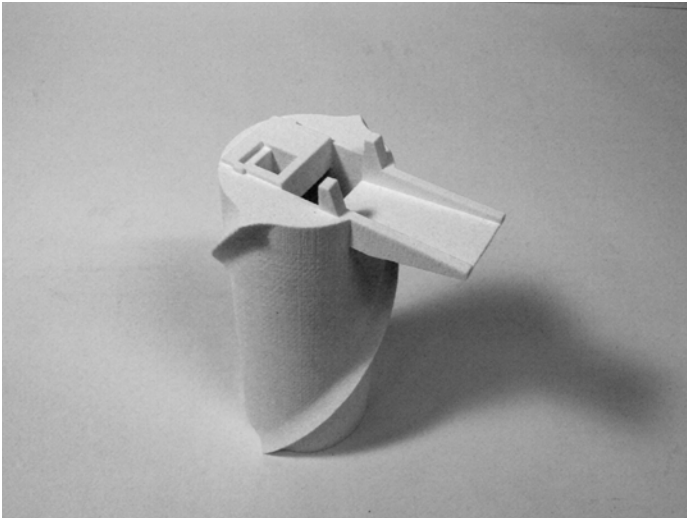

figure 5.1 - 5.8 physical model of the research and development platform

Constructed with one ply chipboard, 1/16" plexiglass, britstol, trace paper, and large stainless steel nuts for stabilization. This was going to have fiberglass resin; I didn't pull through. Bottom cylinder geometry was constructed by Alexis Sabolne.



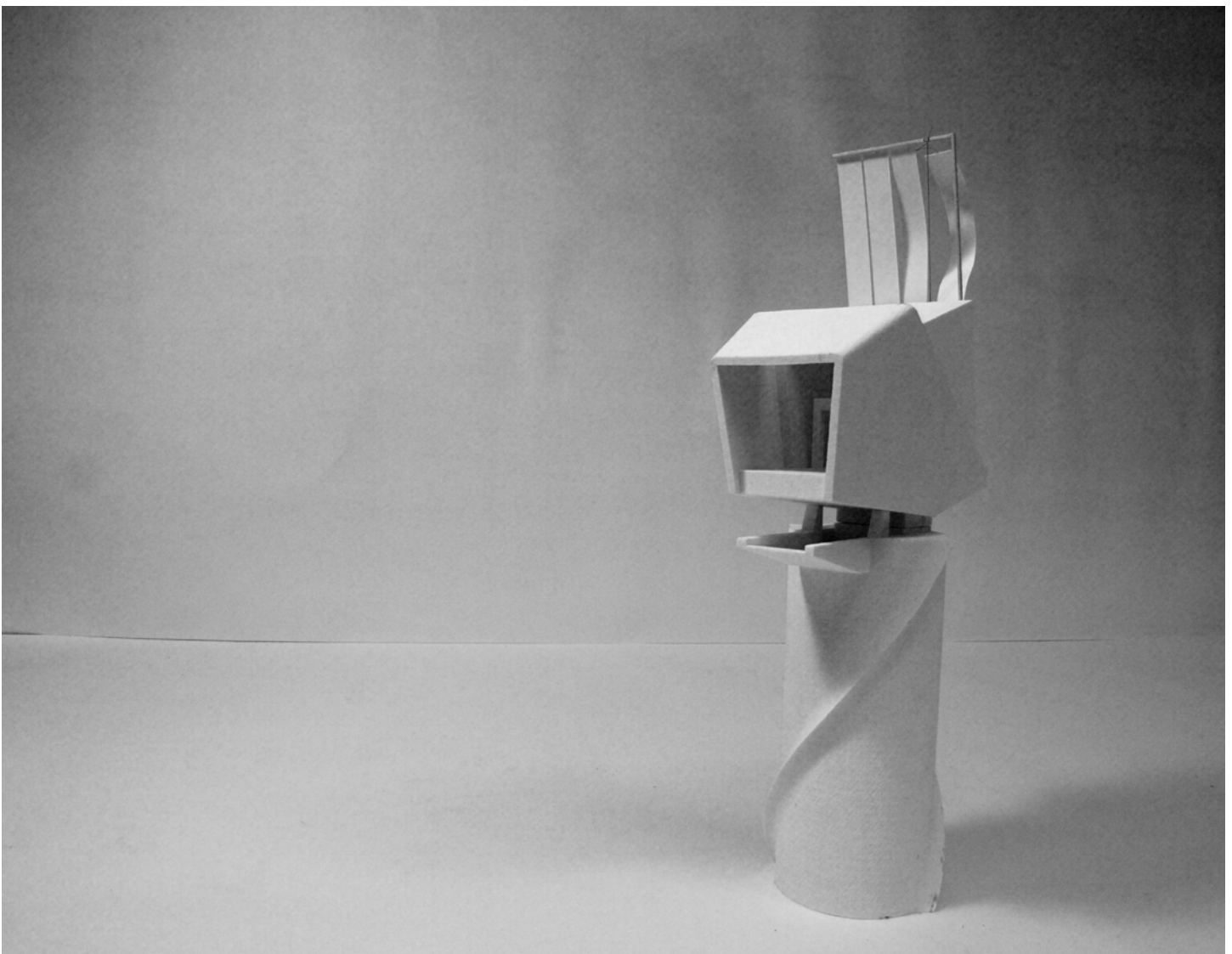
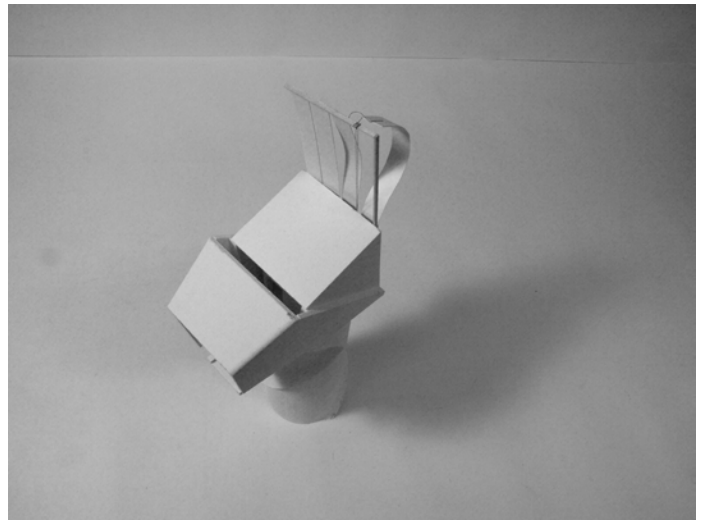
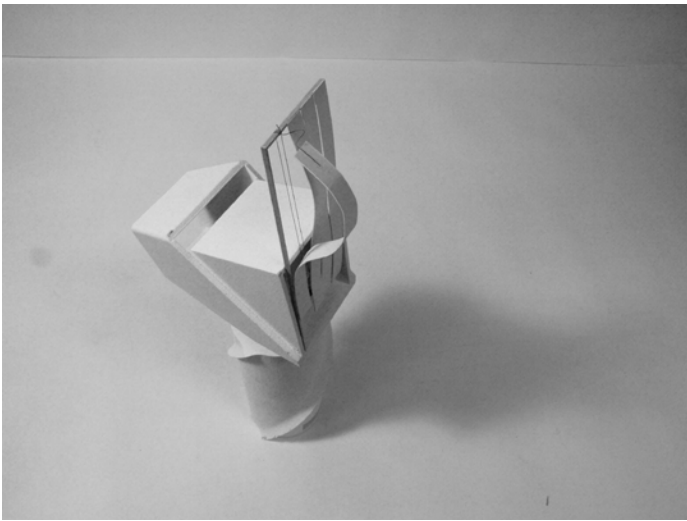
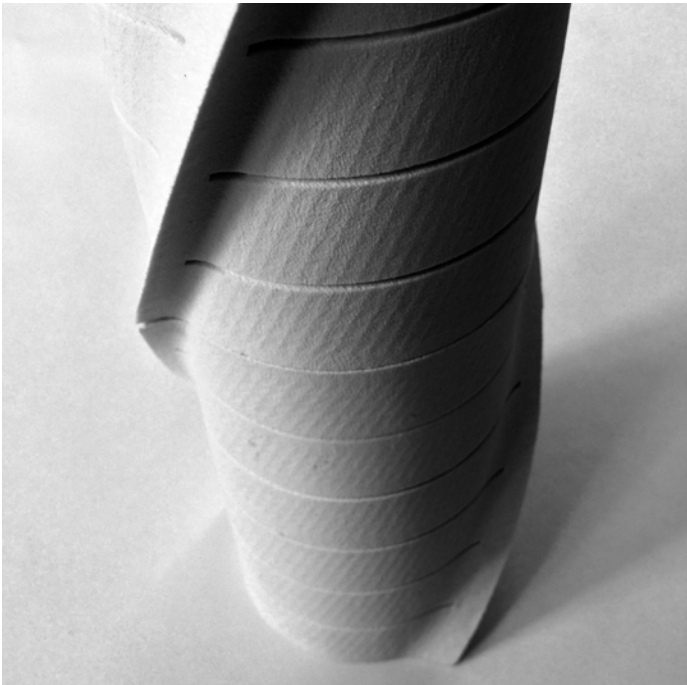
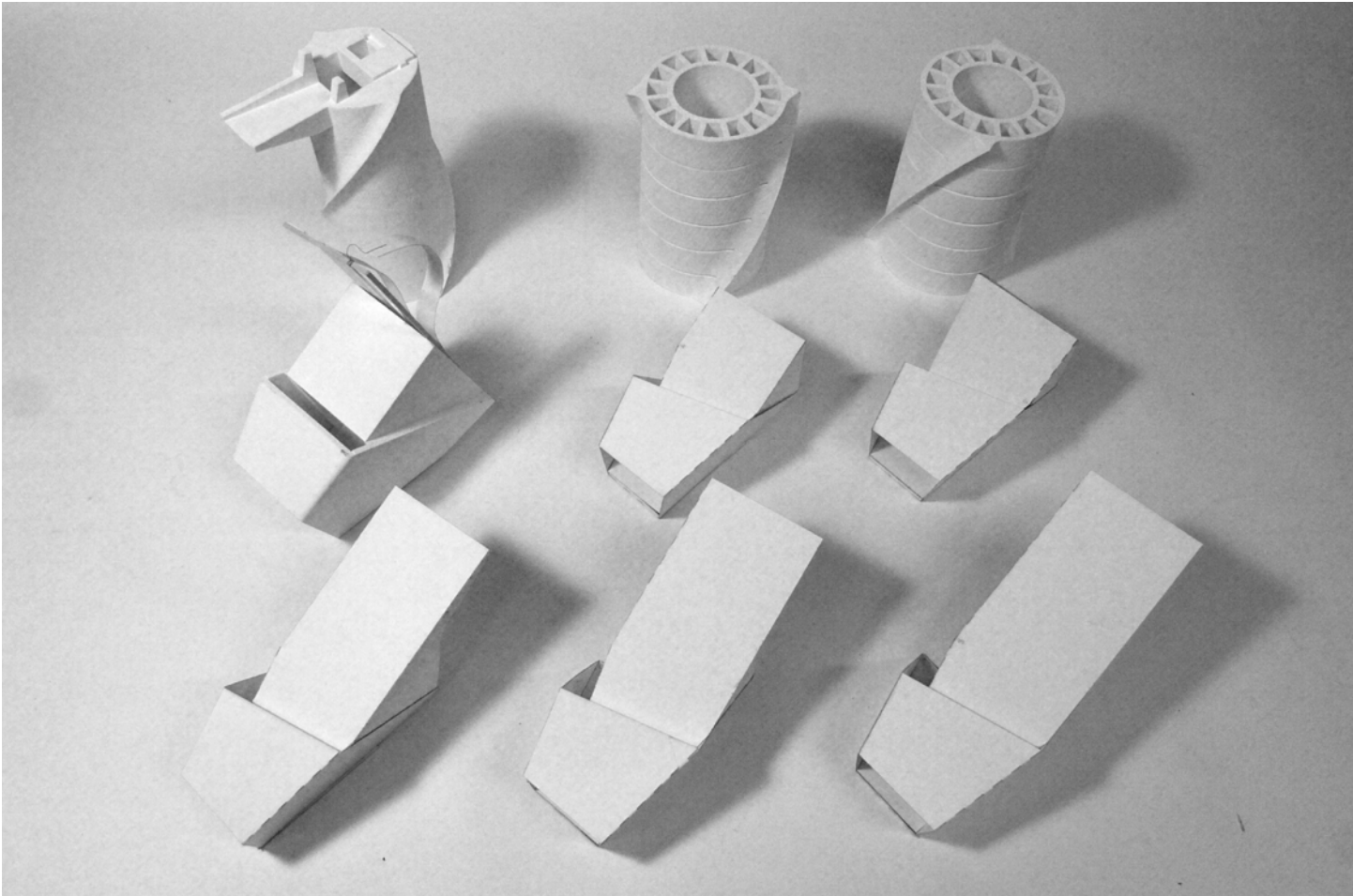

figure 5.9 - 5.18 research and development platform early studies

Constructed with a zcorp 3d printer in two parts: the upper deck hull and the under belly spar. The Bristol and bass wood was added later for the representation of an algae cultivation system.



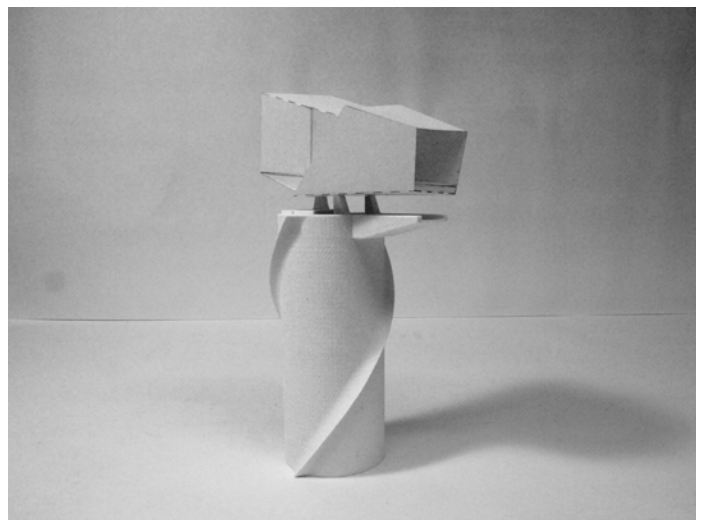
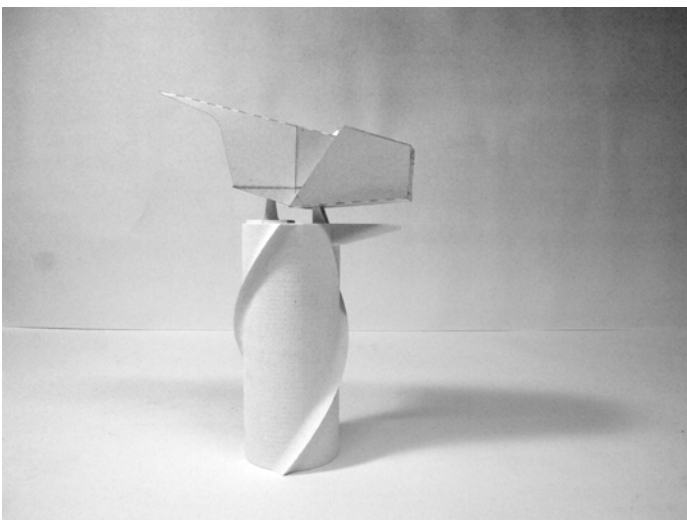
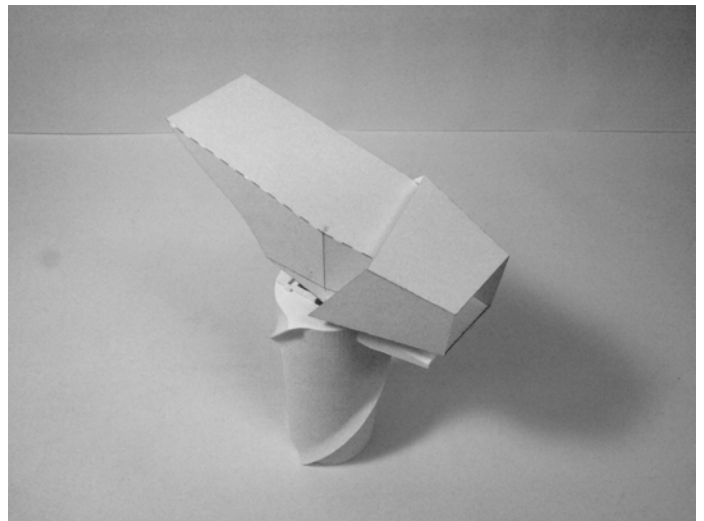
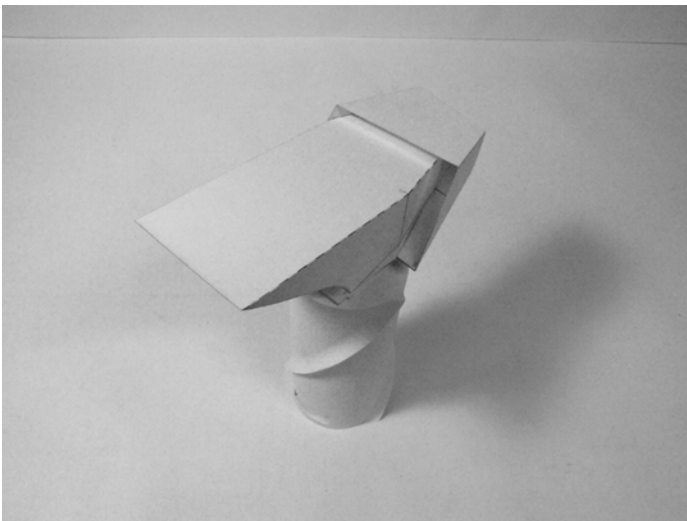
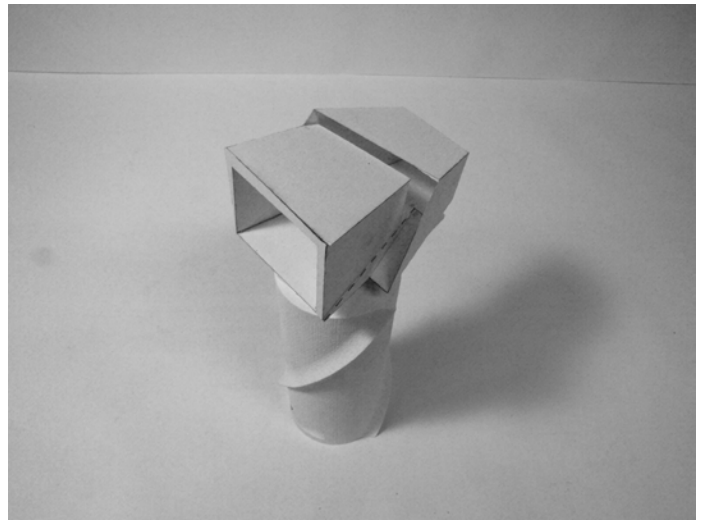
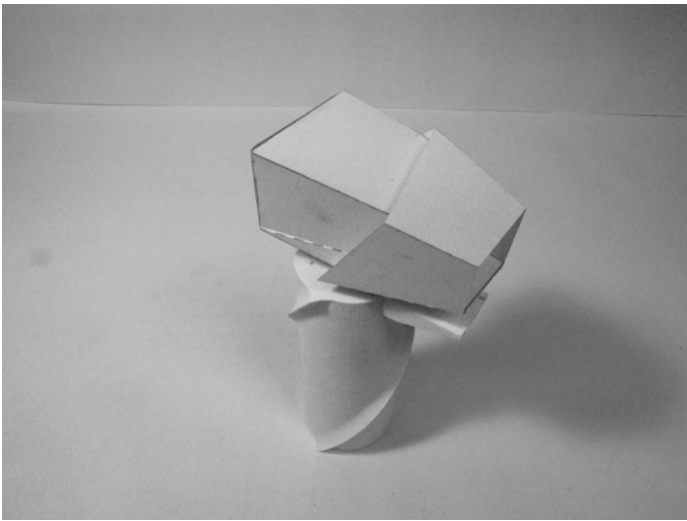
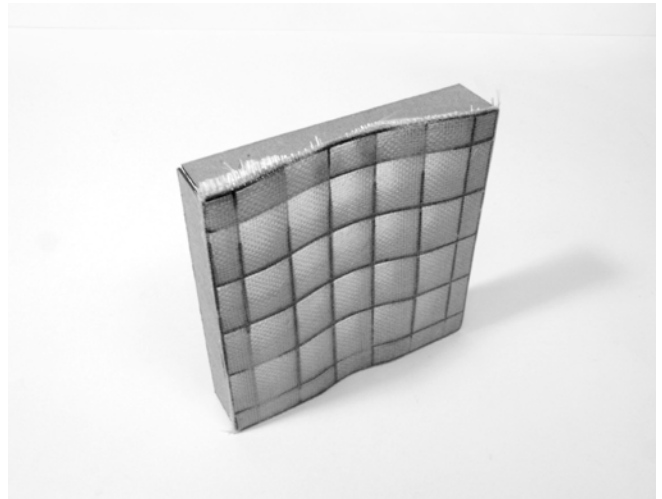
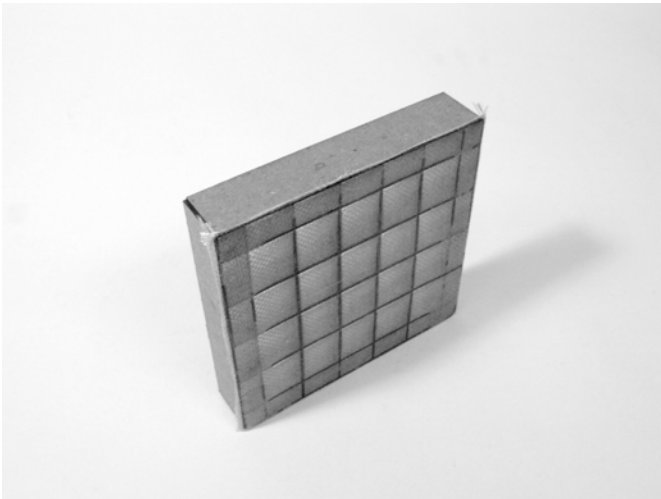

figure 5.19 - 5.27 research and development platform revisions

Utilizing the constructed 3d printed under belly spar as a kind of base for iterating upon the idea of a hull. This was a test to configure a geometry for the hull as well as an ideal geometry to incorporate both cultivation and harvesting systems.



-- Composite Materials --

The purpose of this experimentation is to configure a durable, flexible tectonic system for the hull of each hypoxia remediation unit. The base spar is adopting the petroleum construction method with either a steel truss or concrete module system where as the insertion will utilize different construction techniques.

Since the architecture is dealing with an extremely radical context: hostile seas and violent winds, the immediate reaction is to generate

a tectonic system that calls for complexity in geometry yet simplicity in overall form. The hull is symmetrical and would be constructed similar to a boat hull with double curved surfaces, filleted edges, and grooves for dispersing water back into the sea. Anything to keep the structure from becoming "water logged." In addition, the materiality would follow the same as a boat hull, fiberglass composite system.

The four images above are tests for this type of construction using woven fiberglass cloth, polyester or epoxy resin, and a hardener

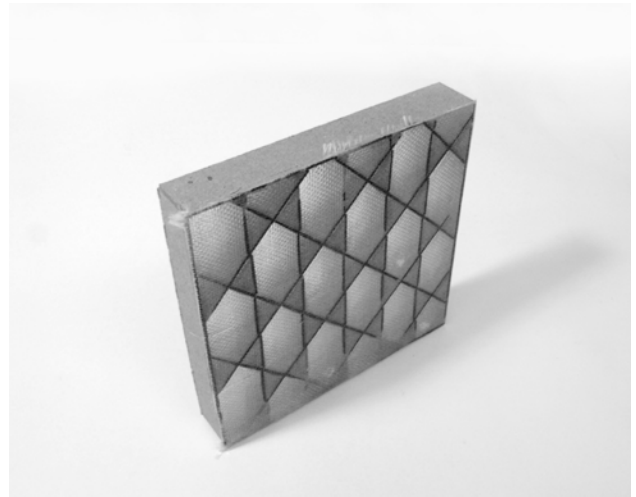
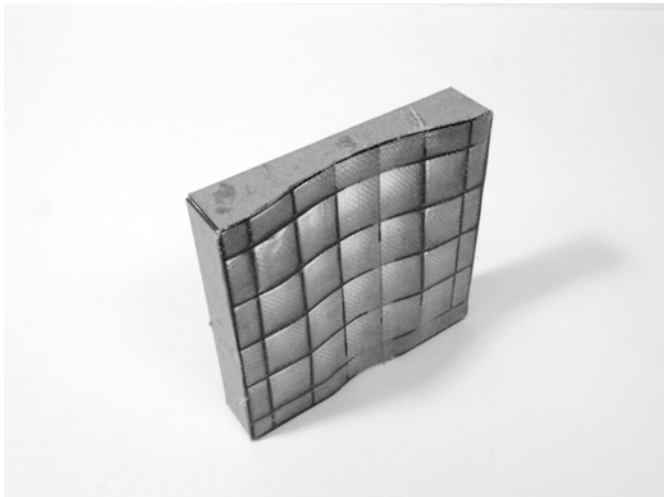

added. The mold is something I had found when looking at surfboard construction. A new technique that allows for the surface to remain transparent. Instead of the mold used solely to make the finished product, it remains within the geometry as a structural supporter. The first image, starting on the far left, is a basic test of the composite system. The surface is completely flat. First, the waffle chipboard is constructed as the mold. Second, two layers of fiberglass cloth are cut with a two inch reveal and layed flat onto the mold. Third, the resin is mixed with the hardener (bondo fiberglass resin; 1oz = 10drops of hardener). The resin is then painted onto the cloth with a foam

brush. This process must be done within 10 - 15 mins otherwise the resin will become too viscous to soak into the cloth properly. With appropriate temperatures (70 degrees) the resin will be dry and the edges can be trimmed accordingly. The other images test durability with one or two layers of cloth, double curved surfaces and triple grids (90 degree grid with a single 45 degree bifurcation at the midpoint).

.....
figure 5.28 - 5.31 fiberglass composite tests

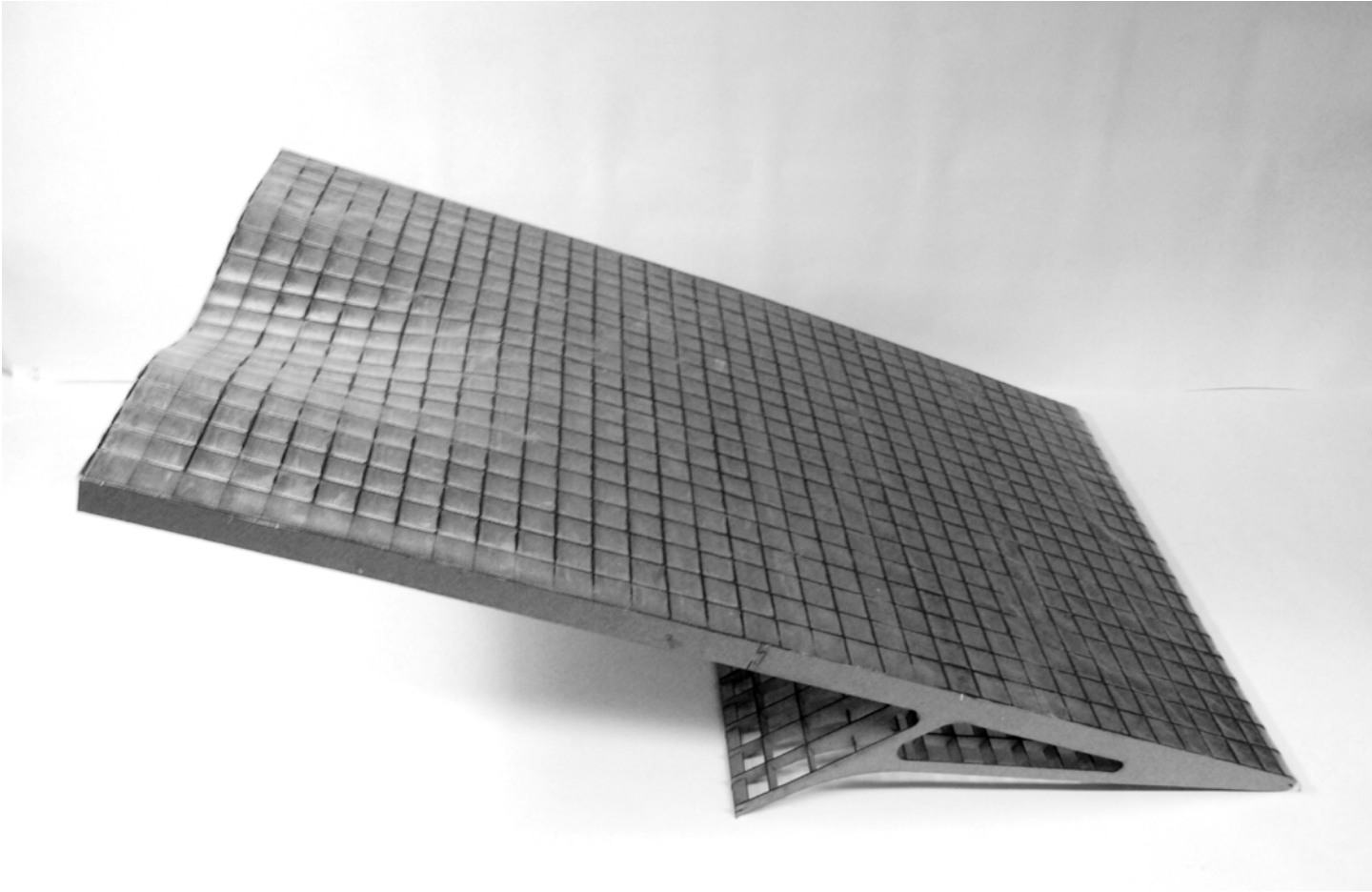
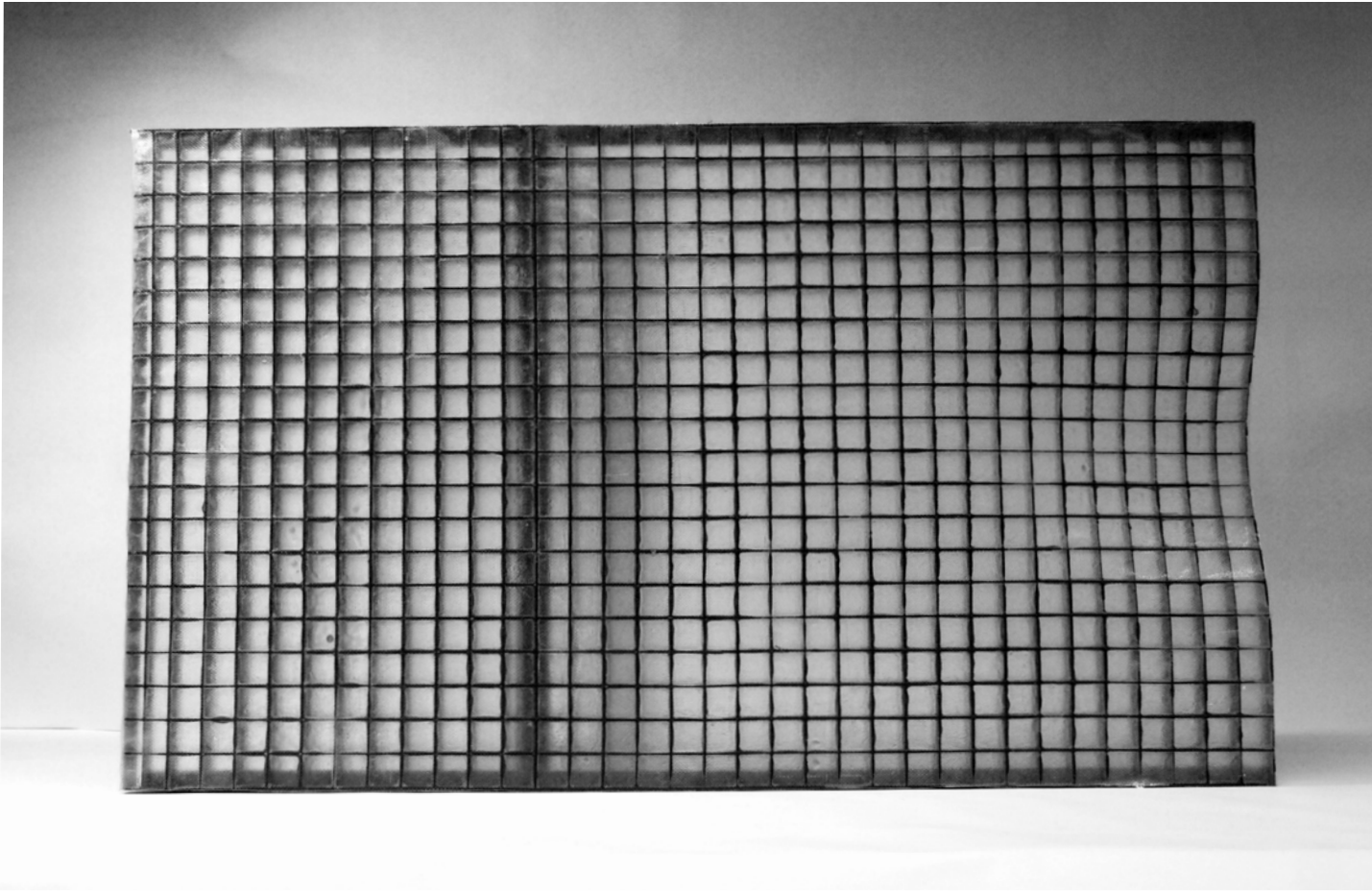

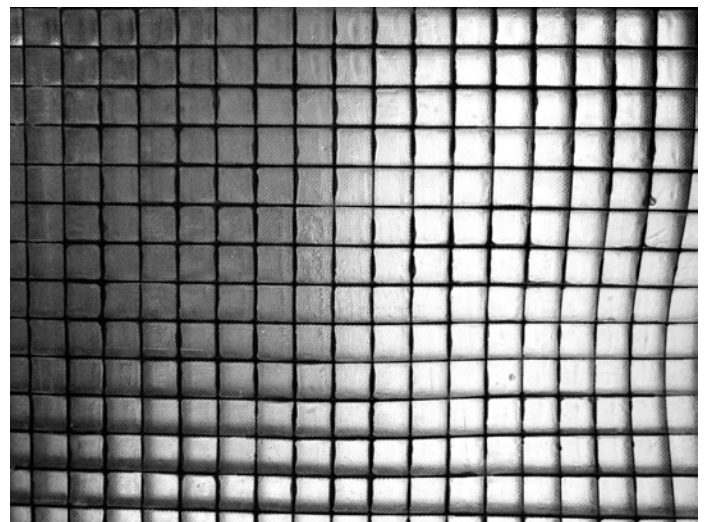
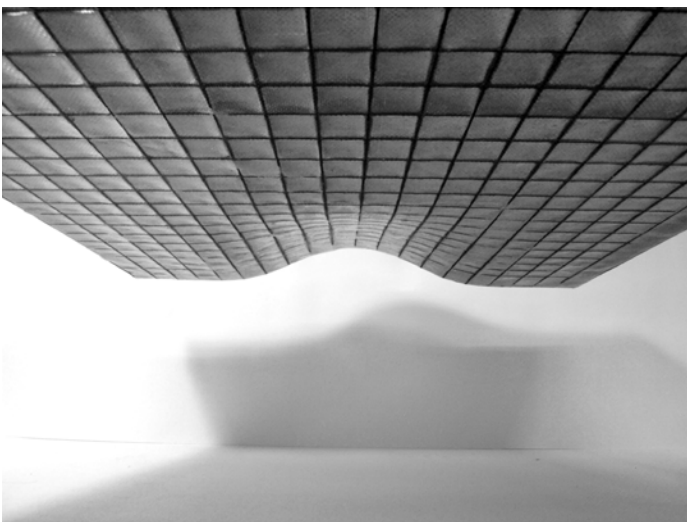
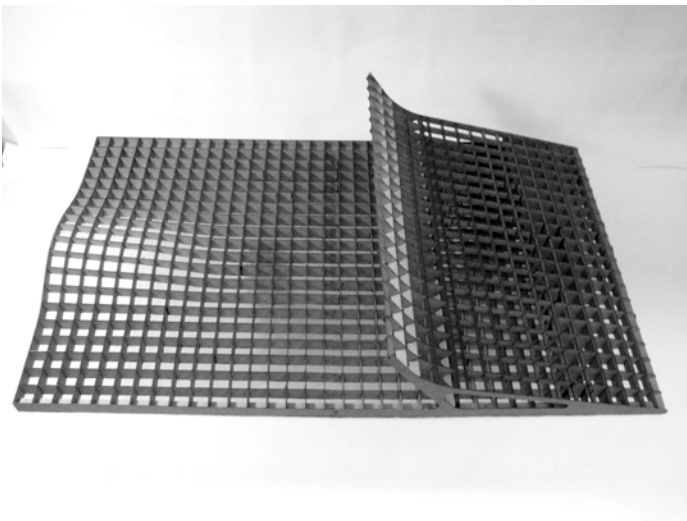
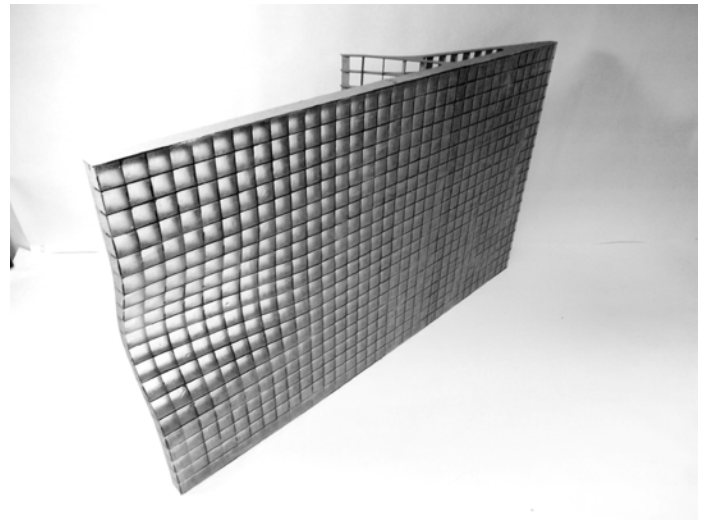
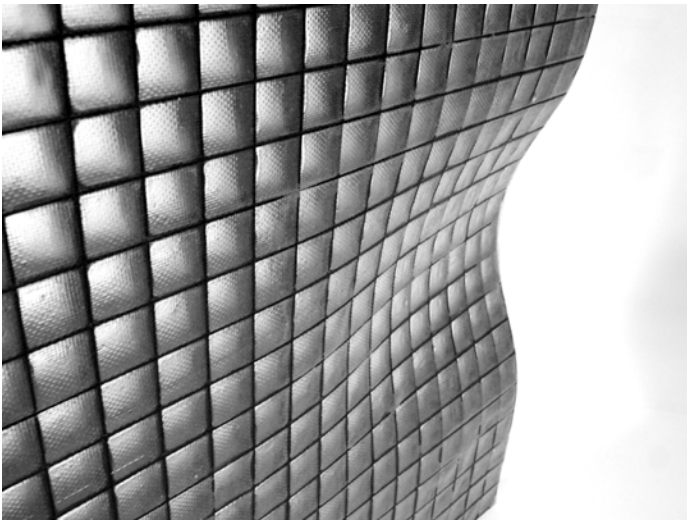
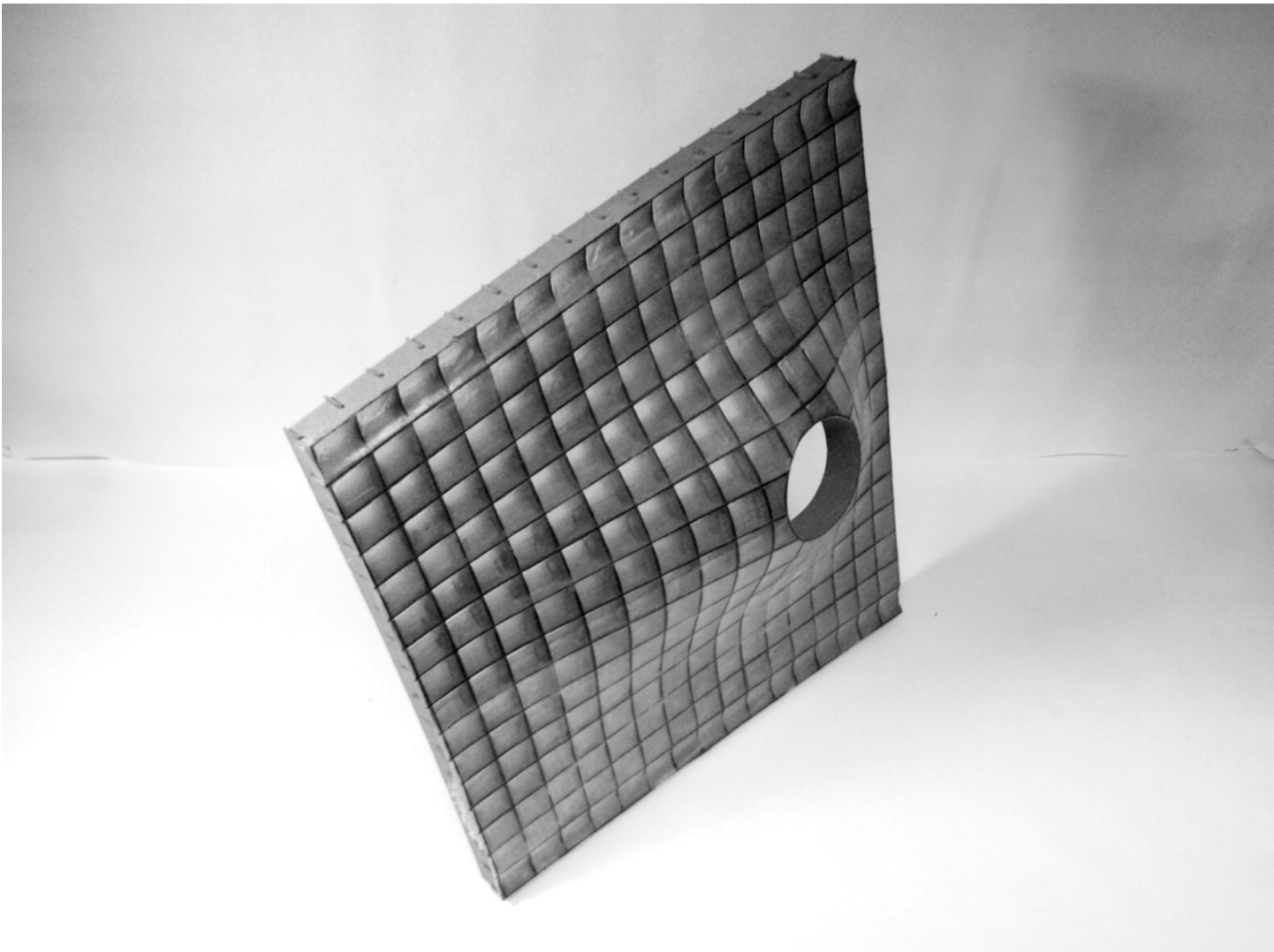

figure 5.32 - 5.39 fiberglass composite hull construction

This first part of the hull is the backside of the research and development platform acting as a receiver for the algae cultivation quarantine package system. The surface turns the corner of the underside and begins to dip down into a water vessel.



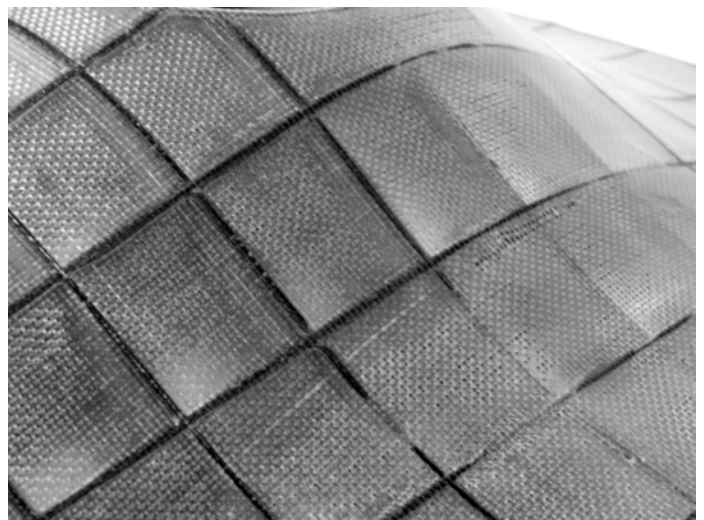
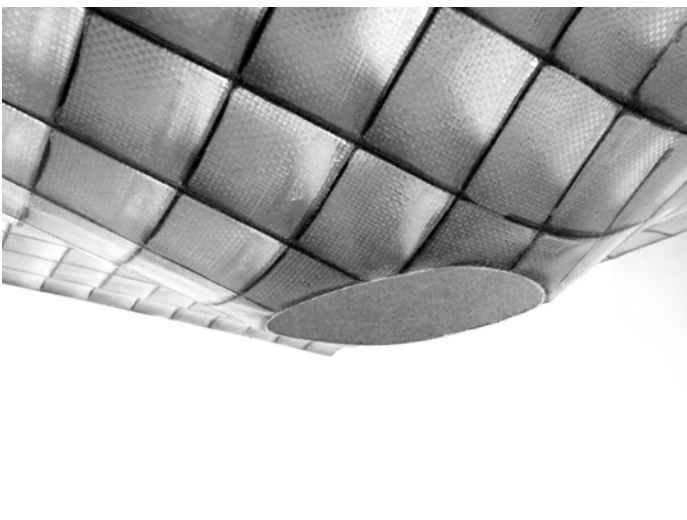
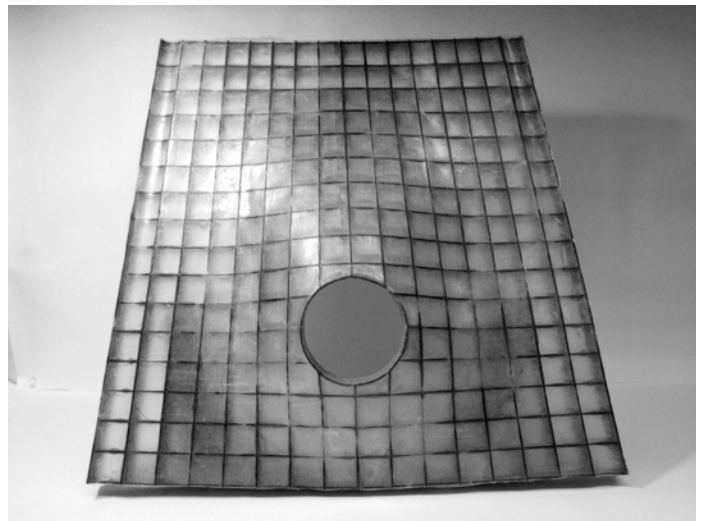
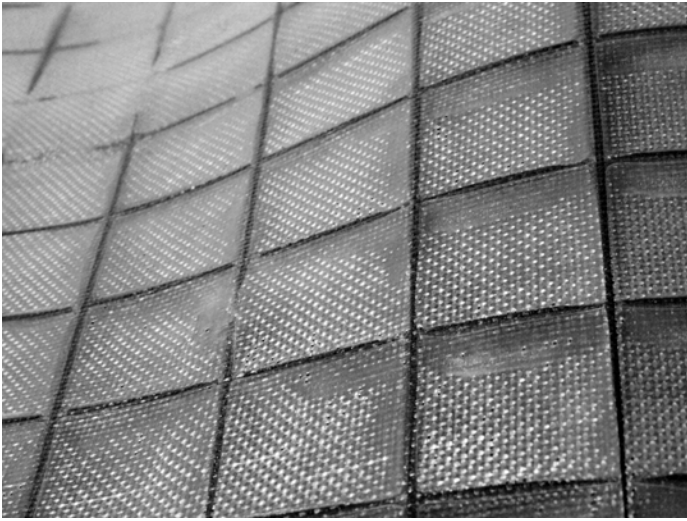
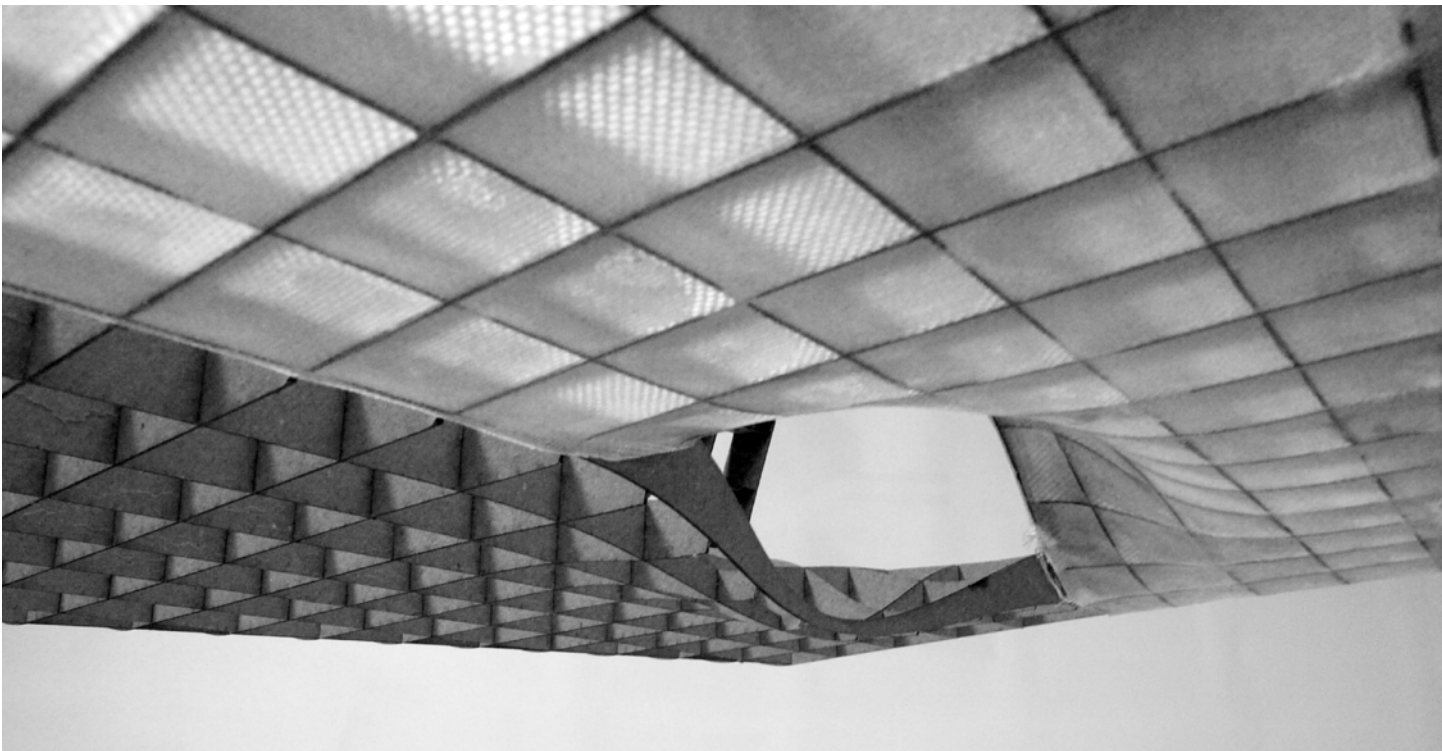
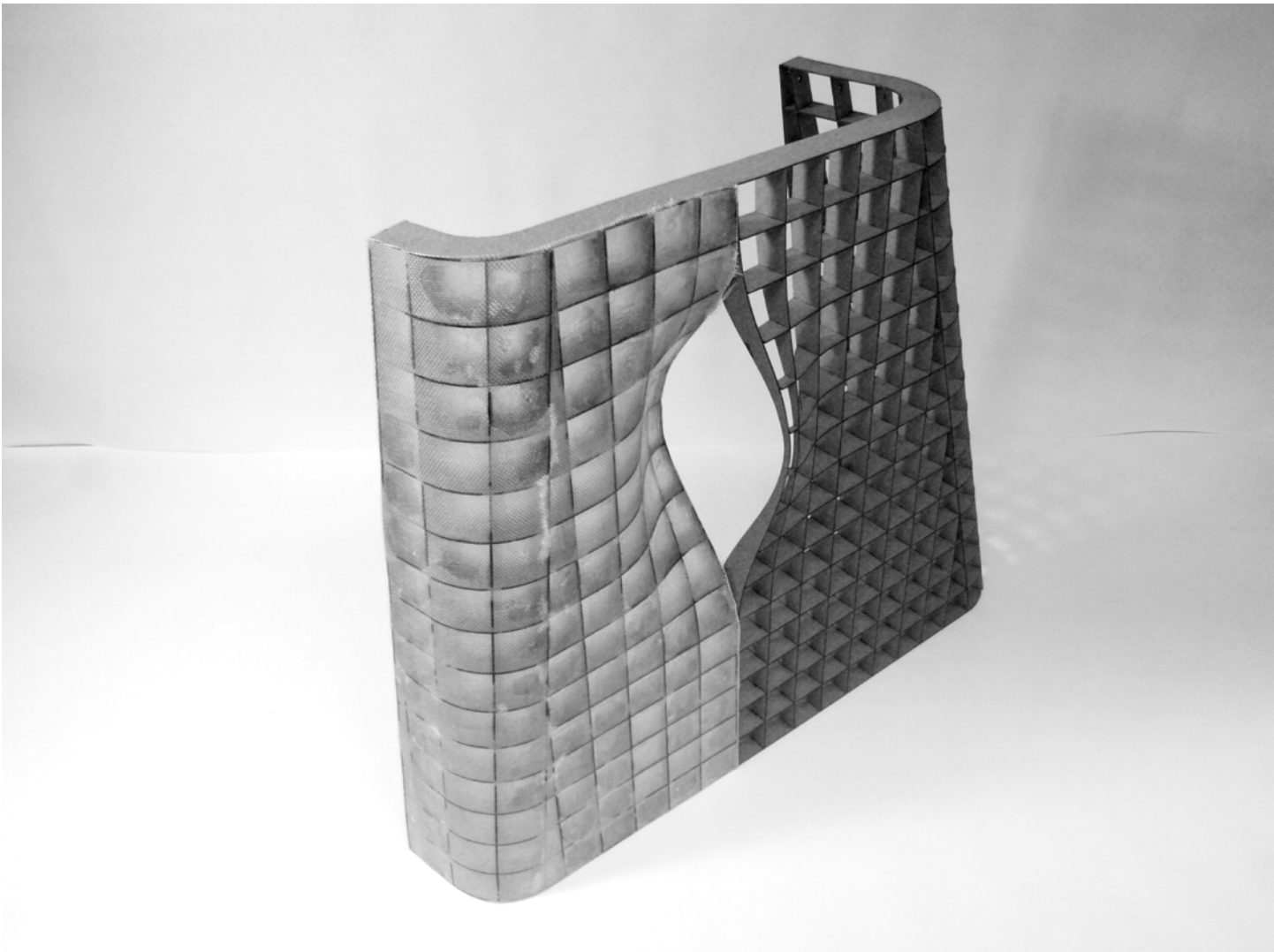

figure 5.40 - 5.47 fiberglass composite hull construction

This second piece of the hull is deck of the algae production space. This particular geometry has gone through many iterations. The purpose is to allow access for harvesting nets moving up and down. The excess water would be efficiently drained.



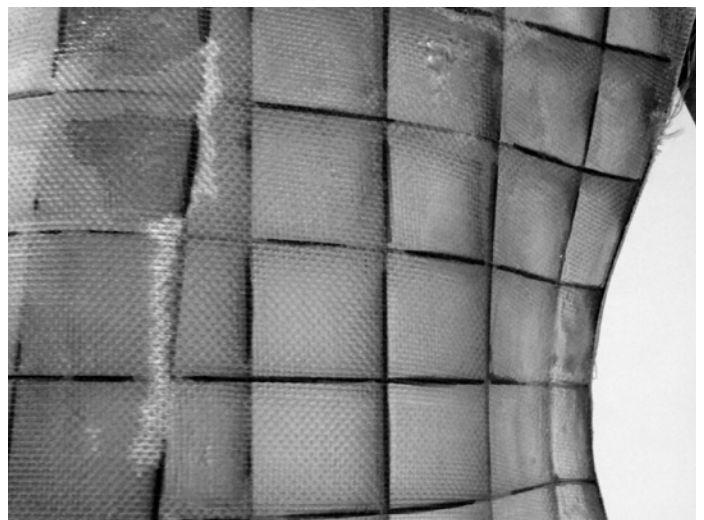
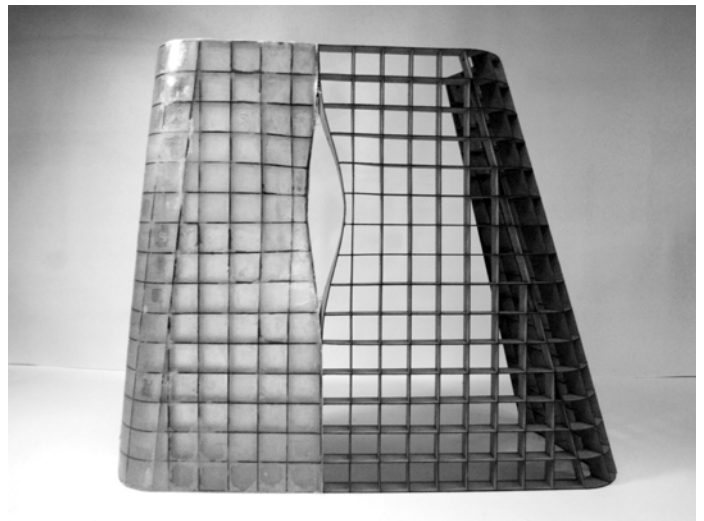
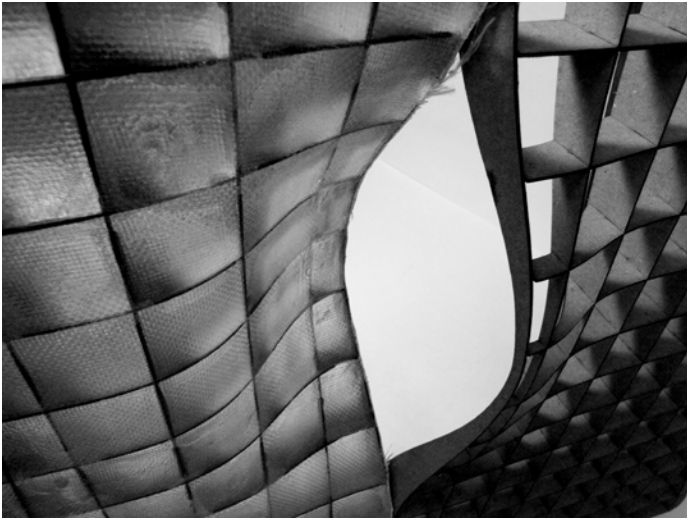
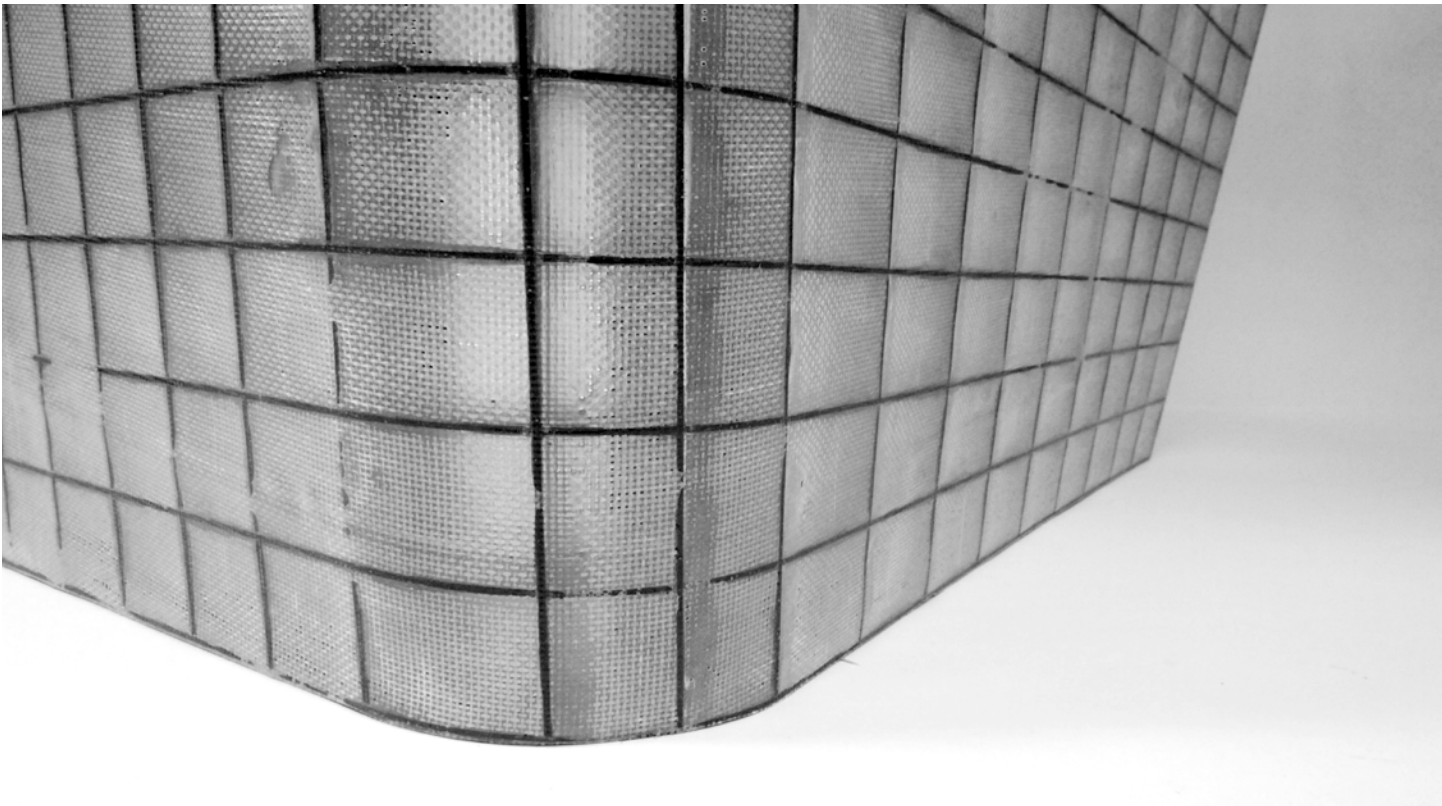
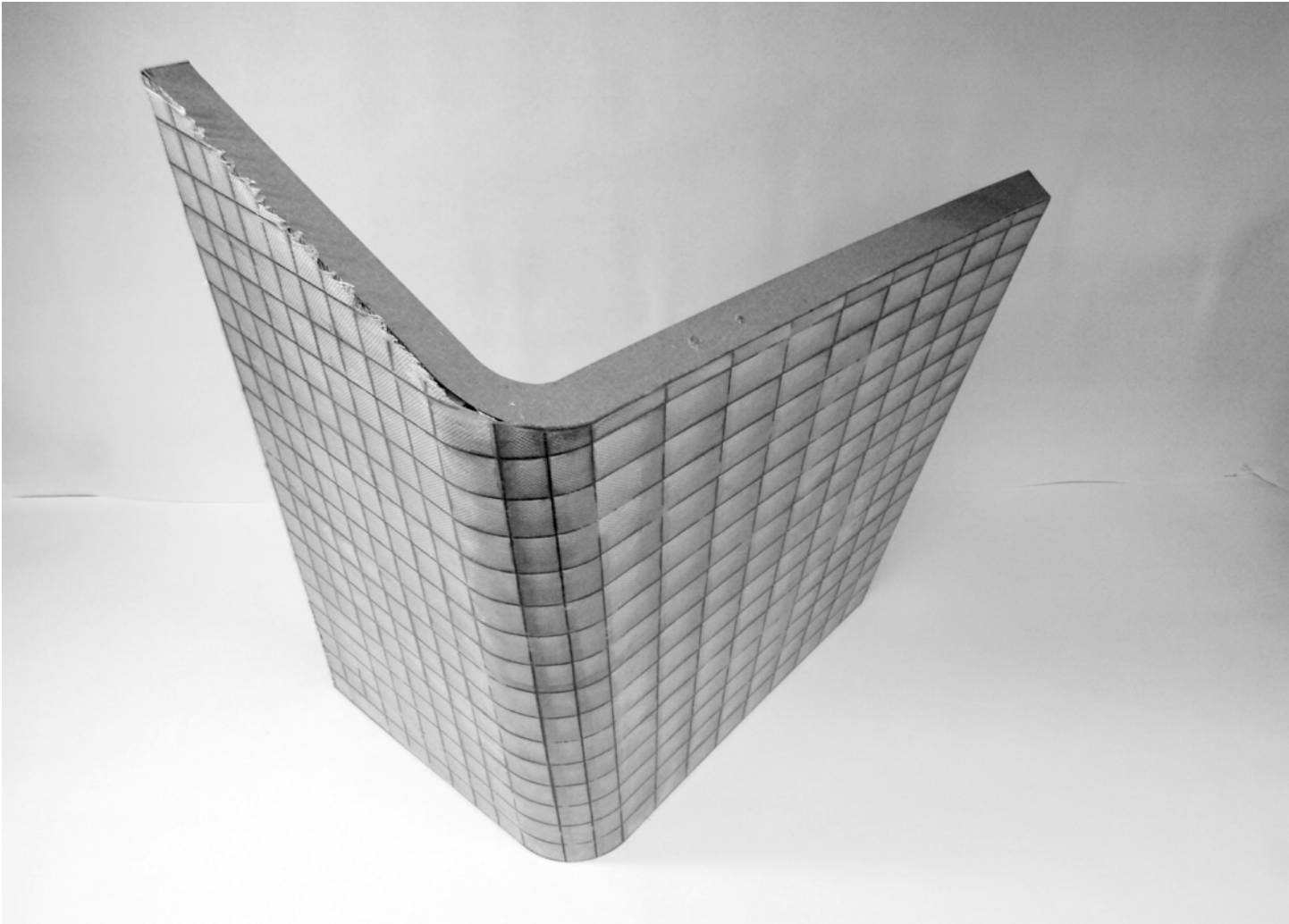

figure 5.48 - 5.55 fiberglass composite hull construction

The third piece of the hull is part of the wall condition splitting its surface to allow for net access. This was an iteration before the previous geometry. The purpose of this test was to create one surface with a spatial condition.



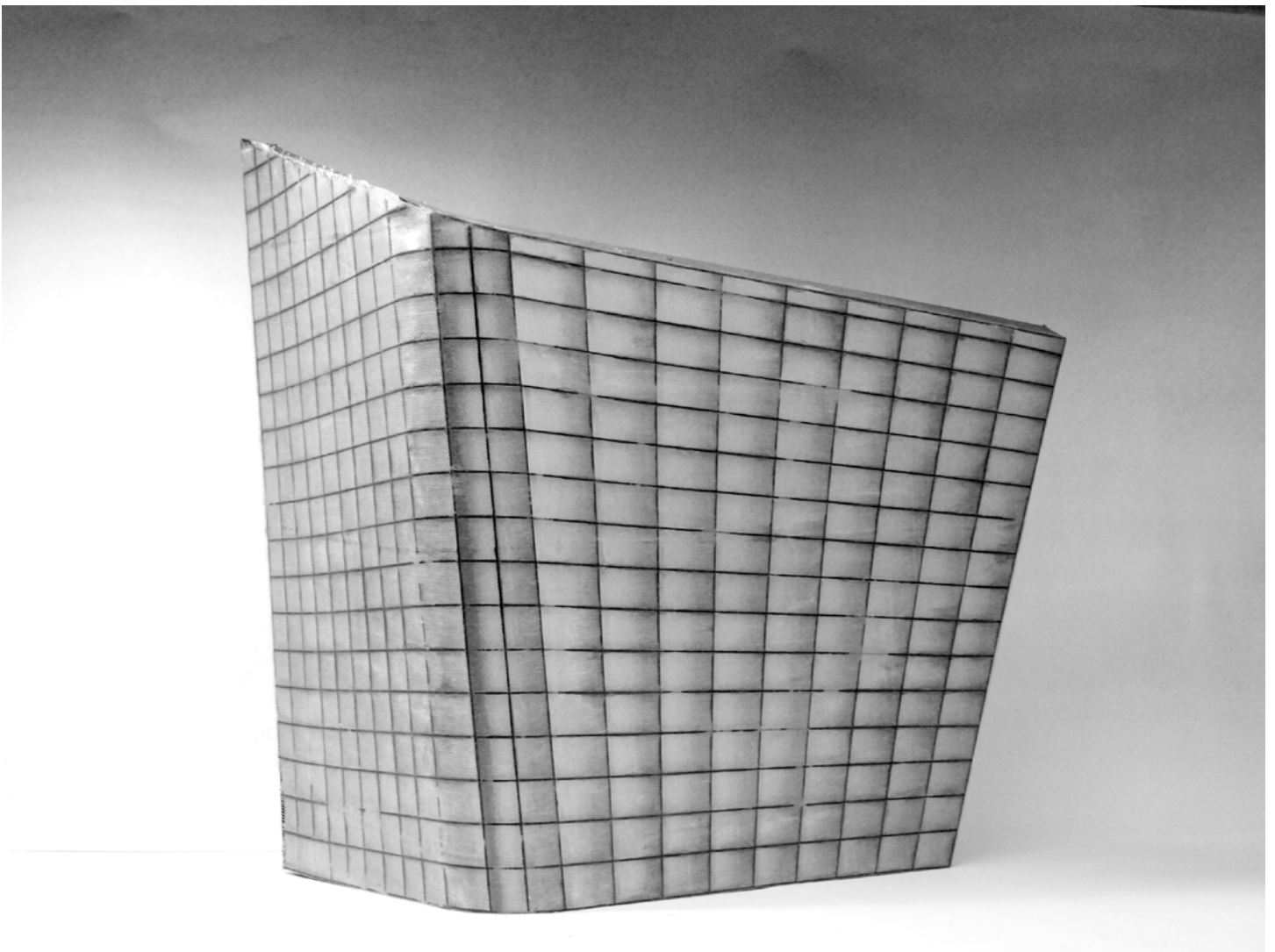
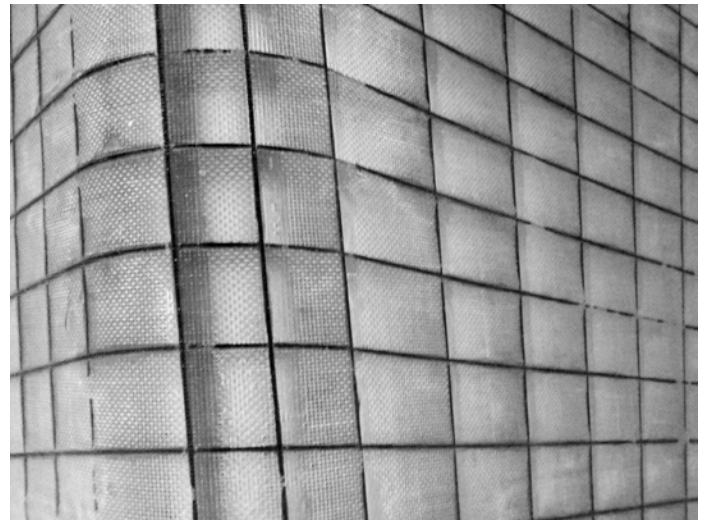
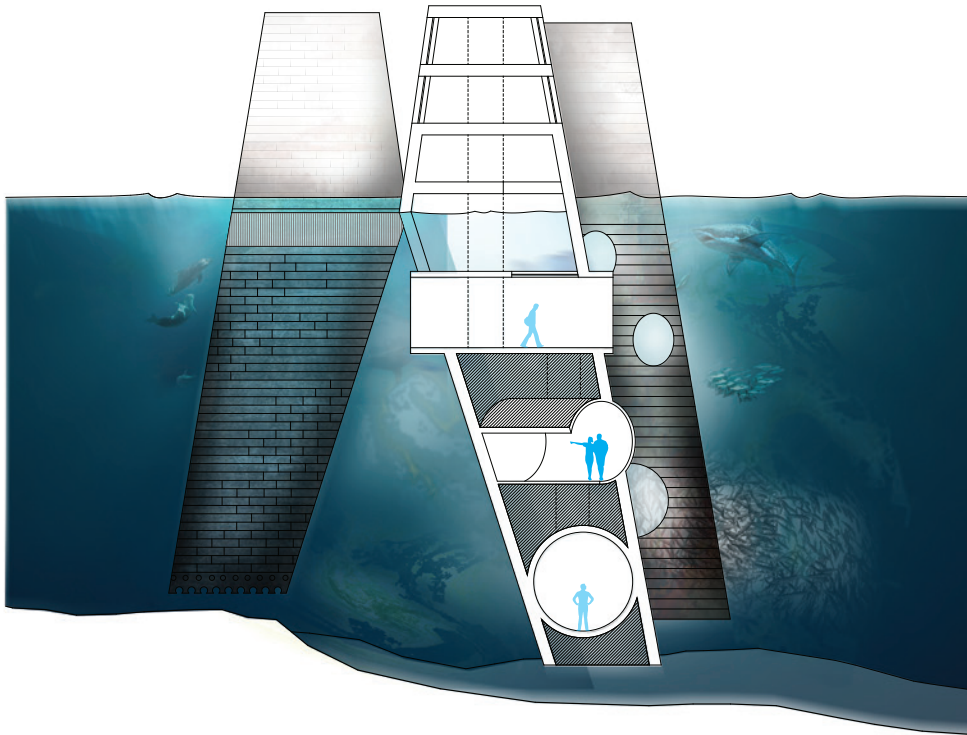
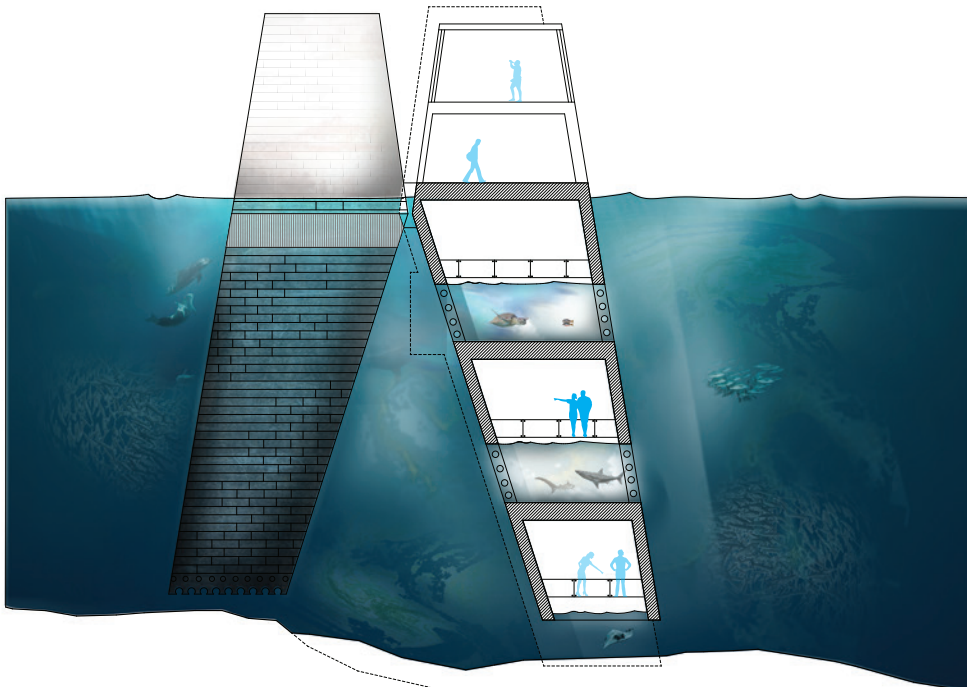

figure 5.55 - 5.59 fiberglass composite hull construction

The last piece of the hull is part of the wall condition turning a corner with a fillet and becoming the overhead condition for accommodation. This type of construction will allow for an air-tight surface expelling any water from the context.



SECTION: SPECATOR
SCALE: 1/8" = 1'



SECTION: SPECATOR
SCALE: 1/8" = 1'



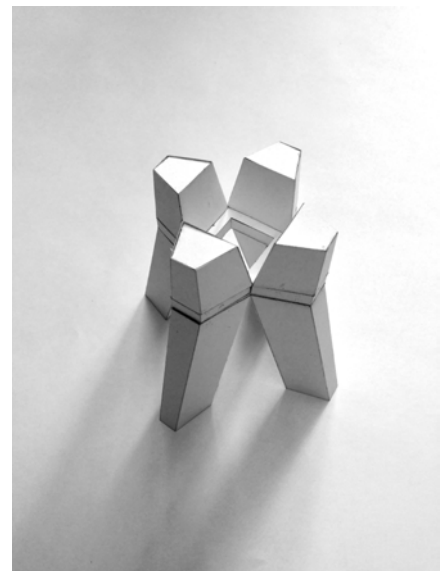
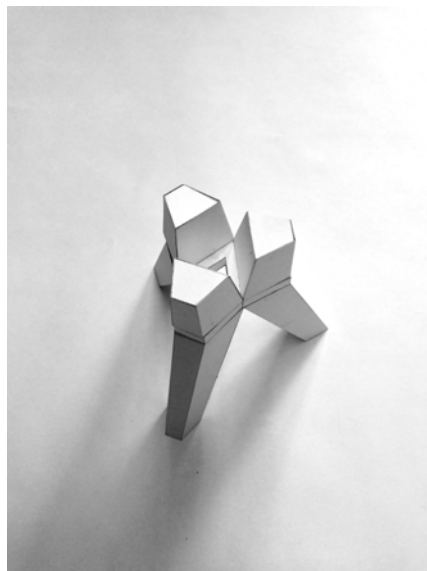
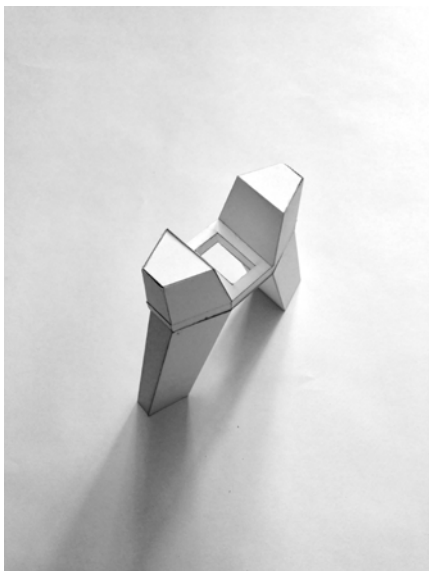
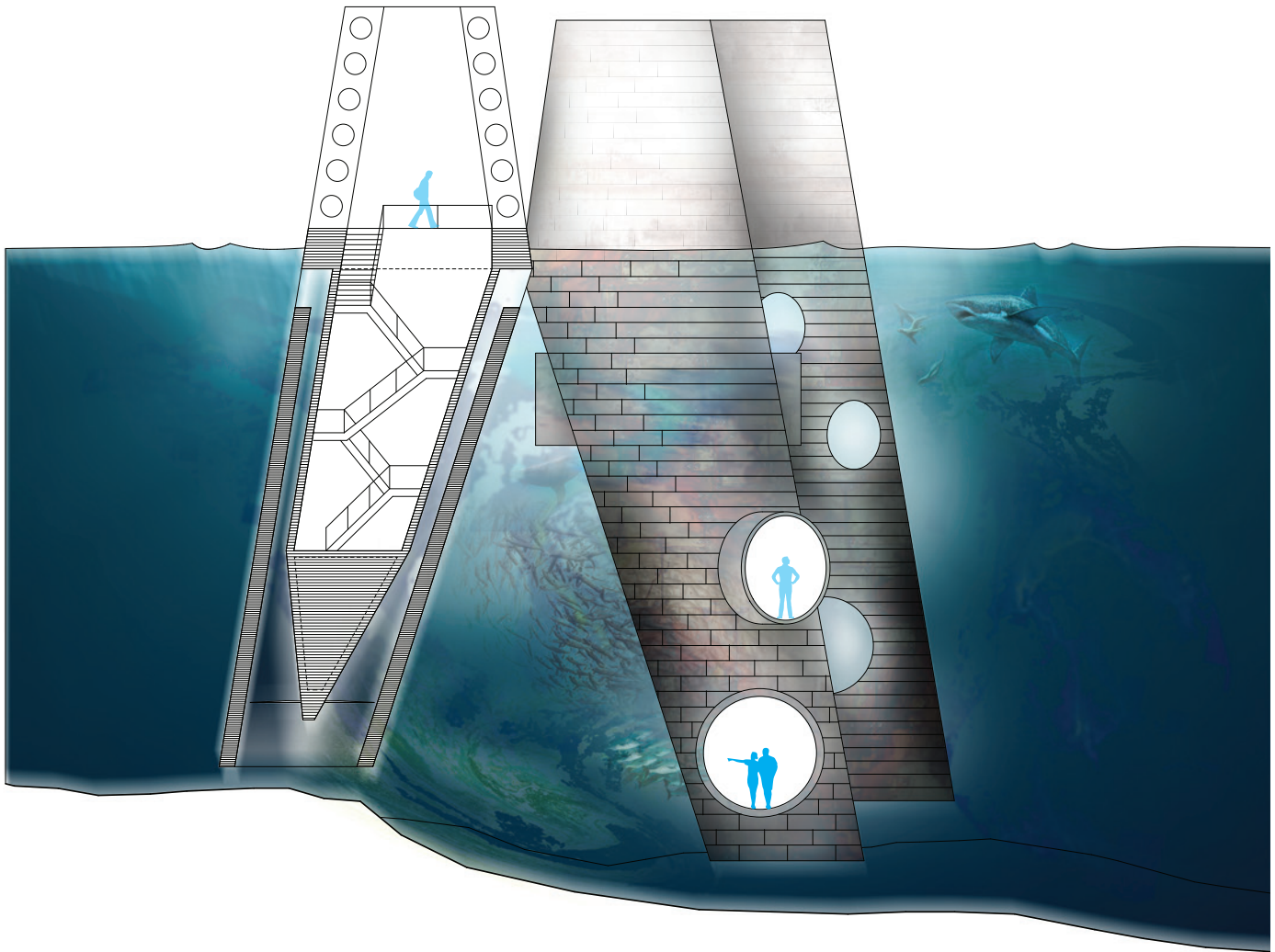

figure 5.60 - 5.65 Review I

The following images are from the first review with reader Anton Garcia Abril, and Andrew Scott. The sections are looking at different modalities of viewing marine life and the models are searching for ideal forms for the context.



figure 5.66: circulation and aeration spar

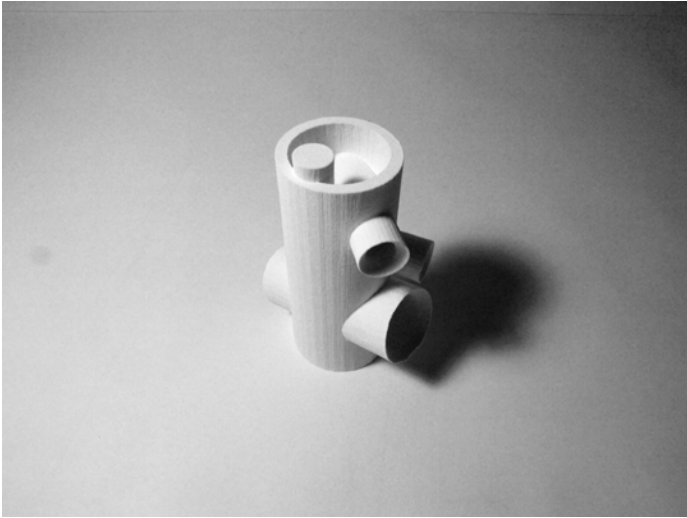
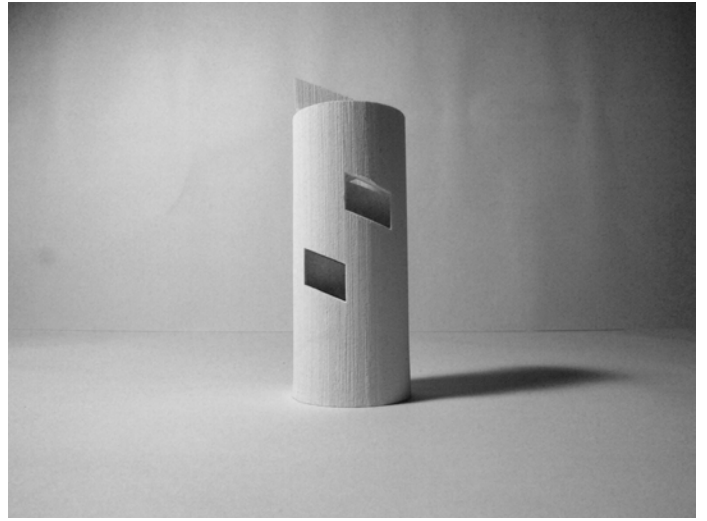

figure 5.67: viewing platforms for the entire water column

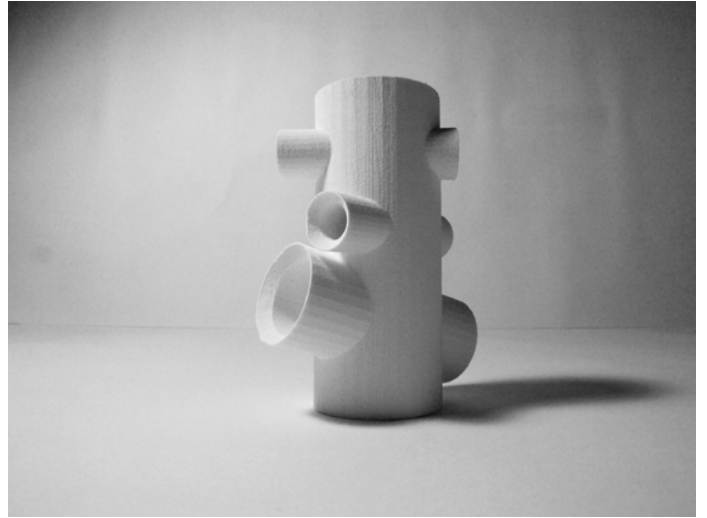
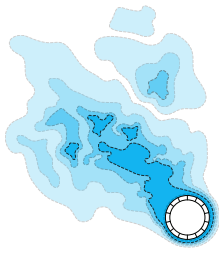
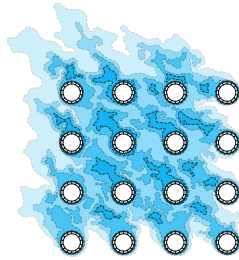

figure 5.68: Viewing pools utilizing pressure with air-tight chambers





SINGLE AERATOR



MULTIPLE AERATORS

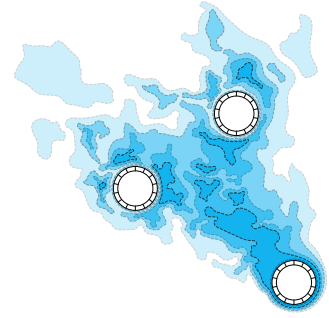

SINGLE AERATOR + 2 RETRIEVERS

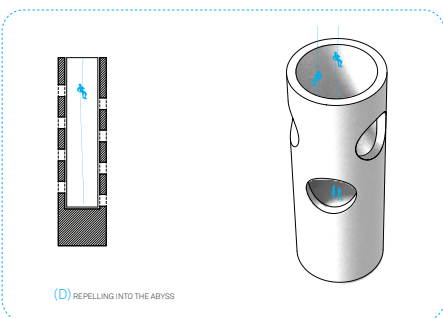
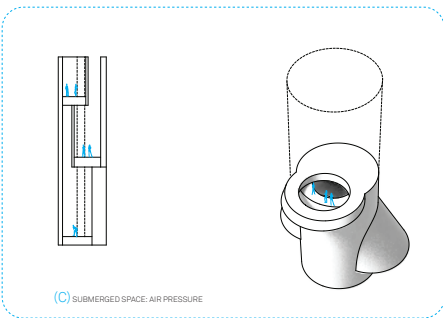
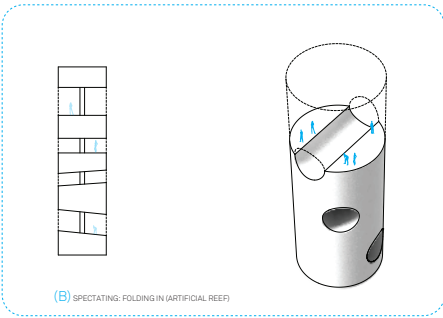
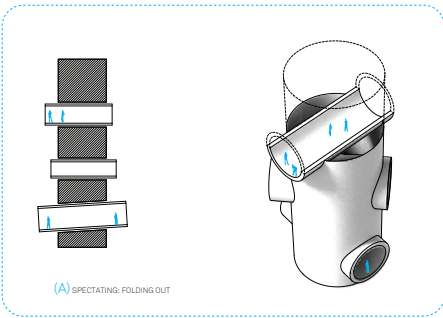

MODALITY OF SPECTATING
AQUARIUM TYPOLOGIES

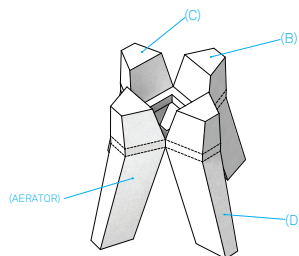
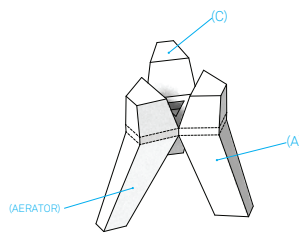
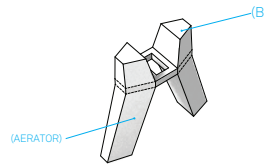
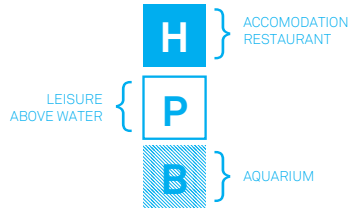

COMBINATORY MODALITIES
AQUARIUM + AERATOR

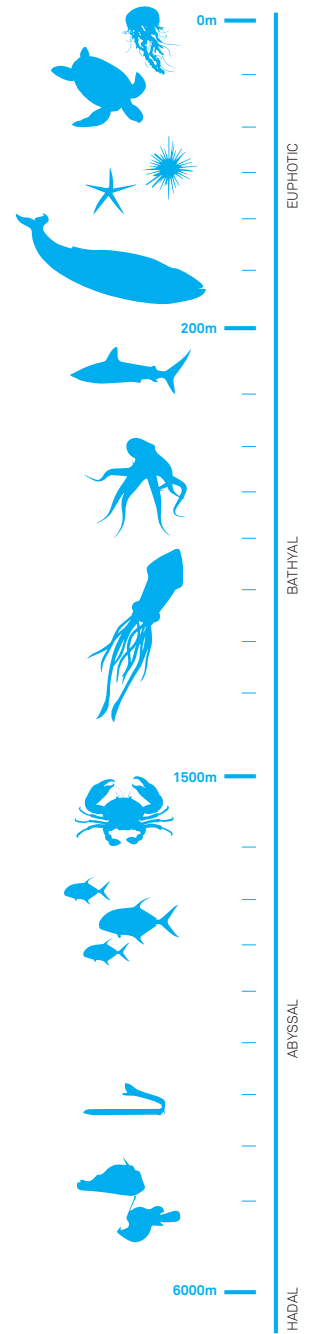

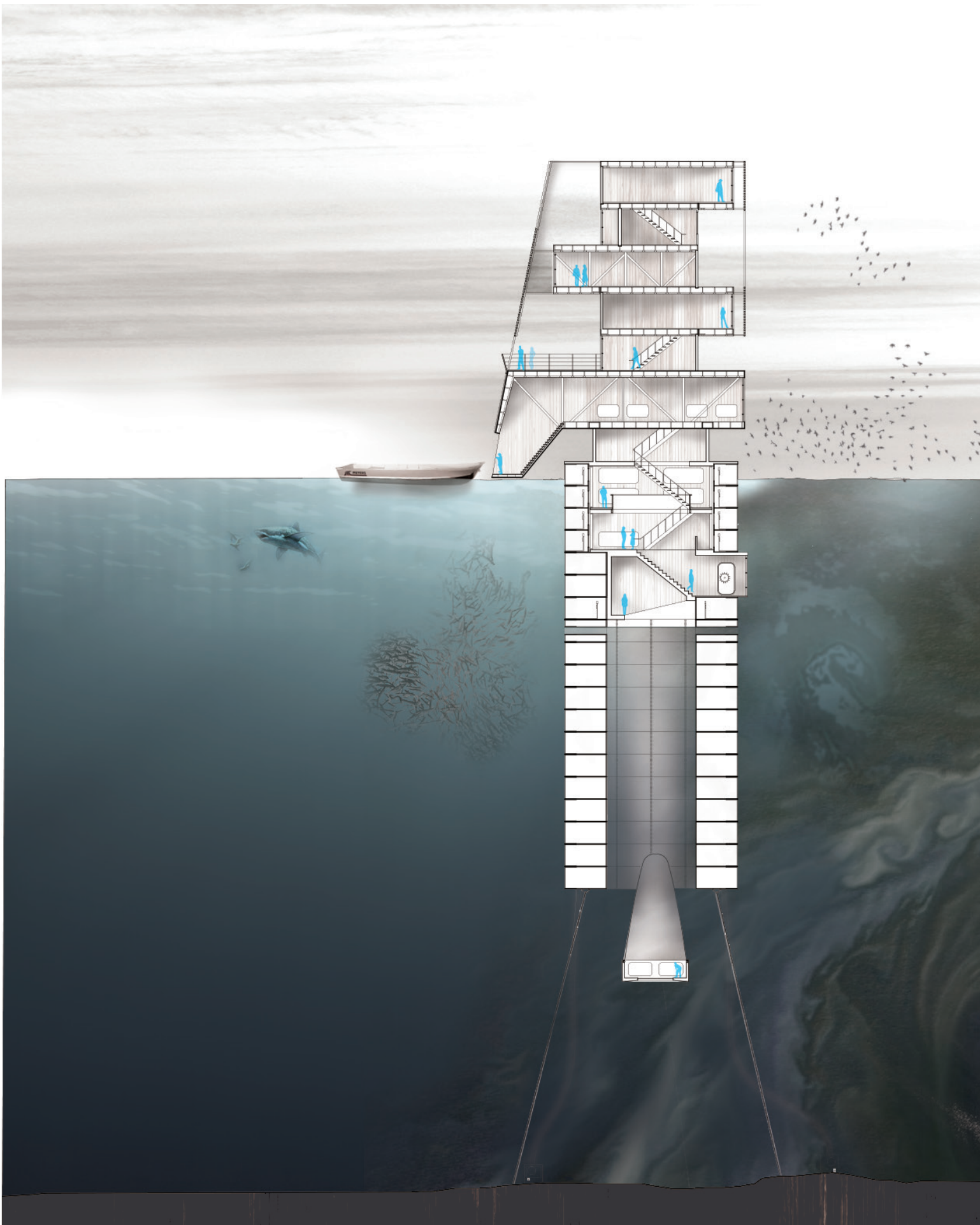

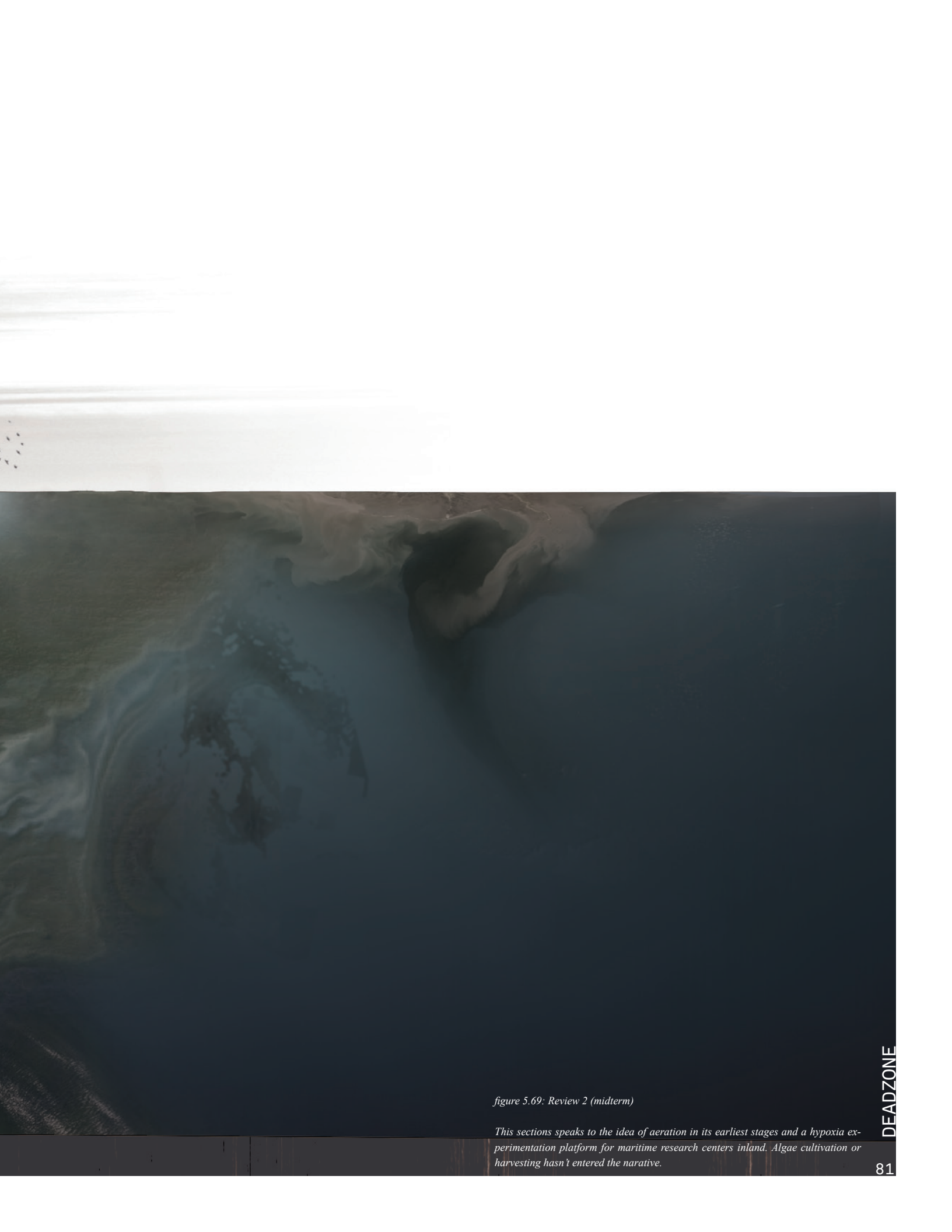
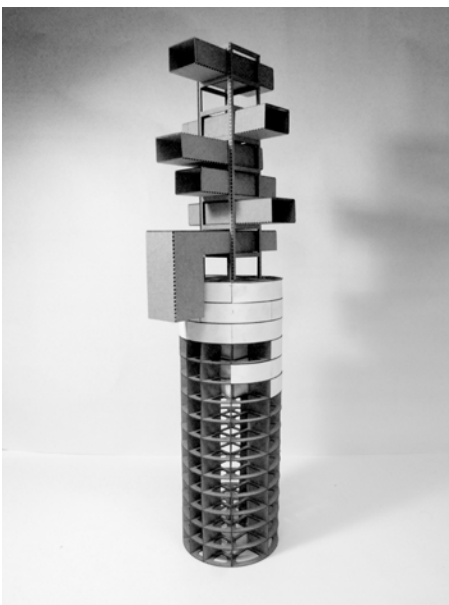
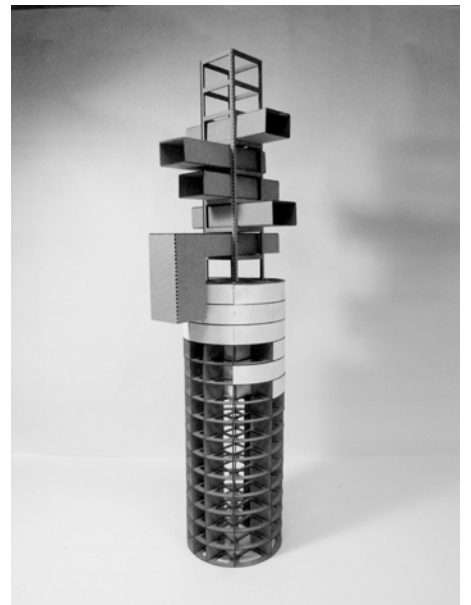
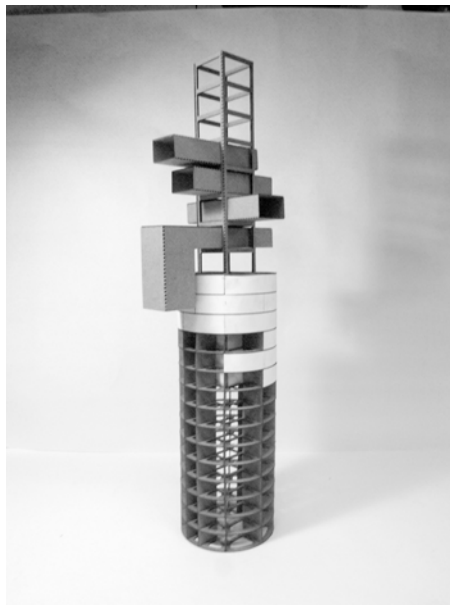
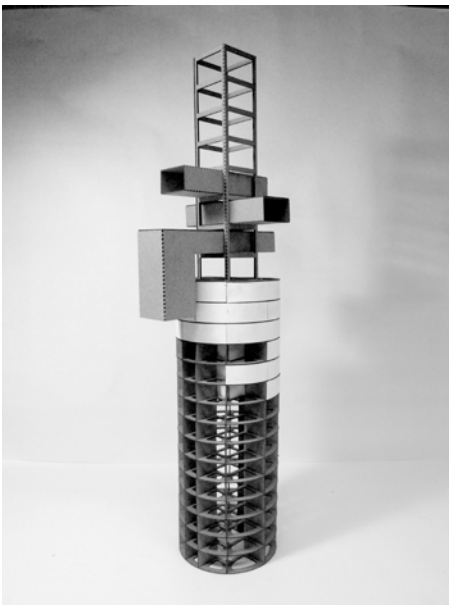
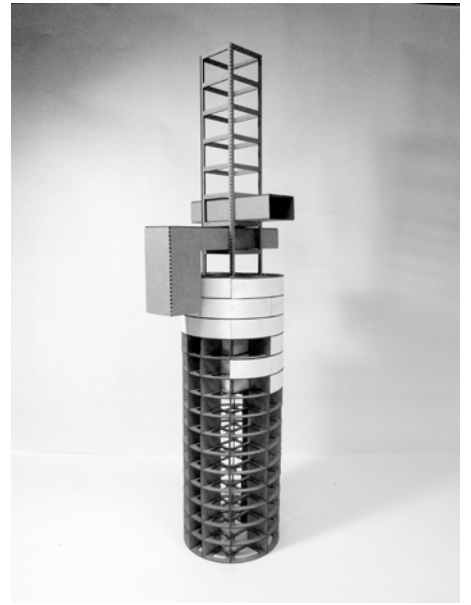
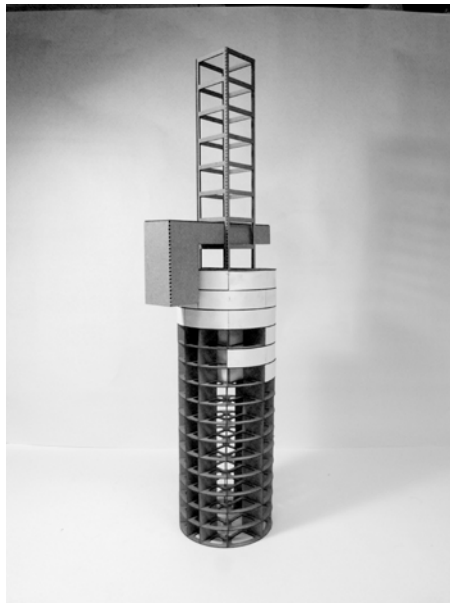
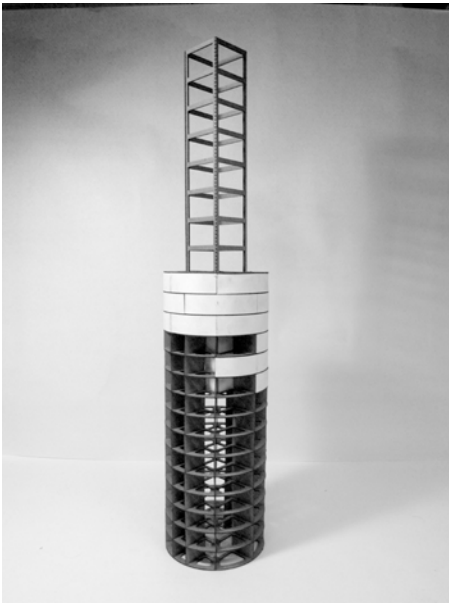
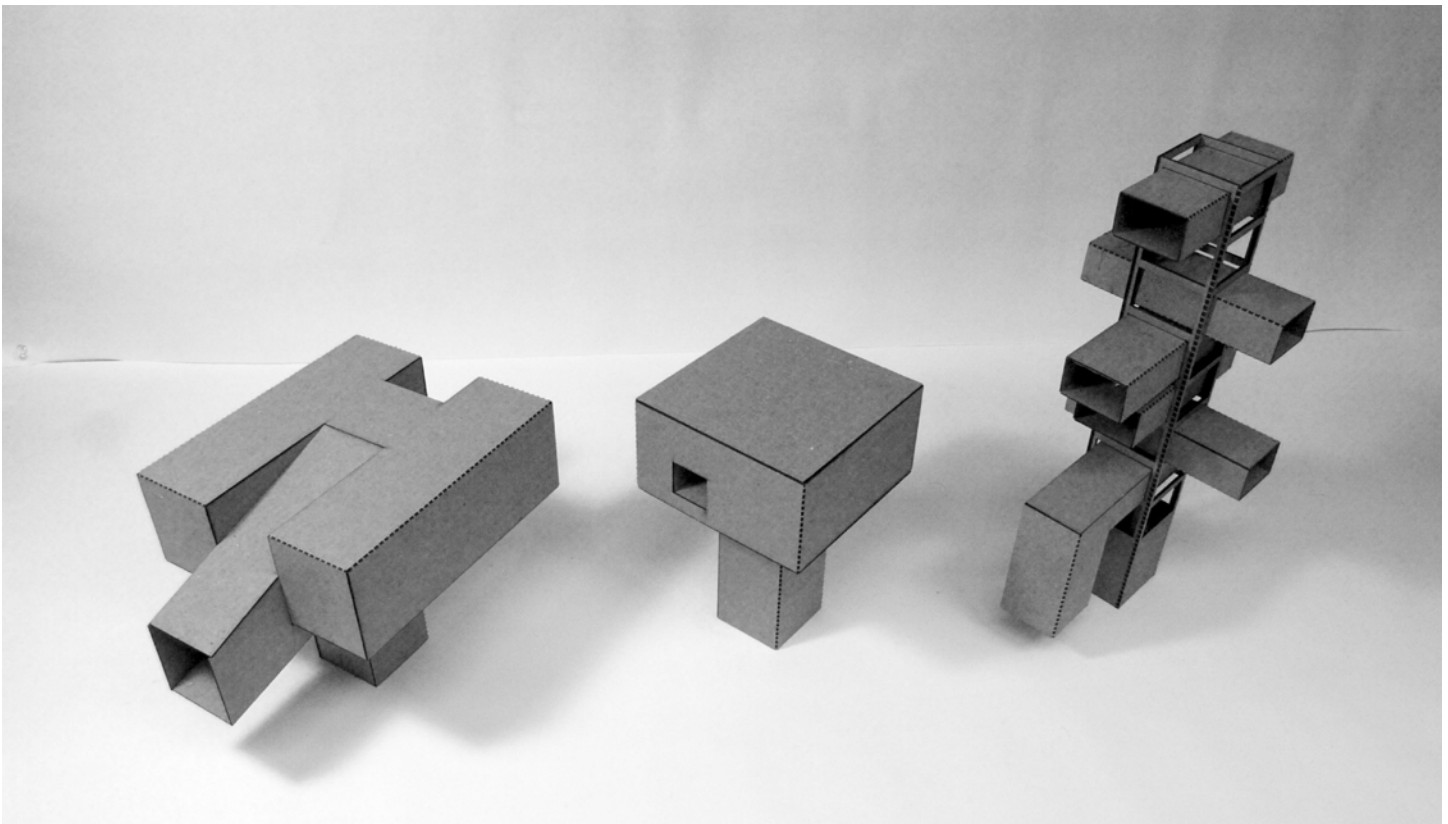
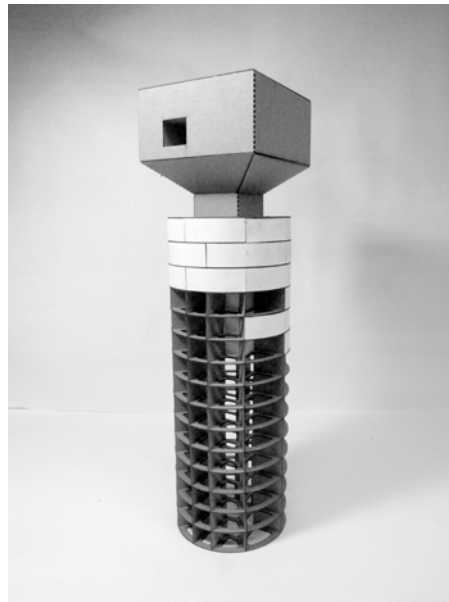
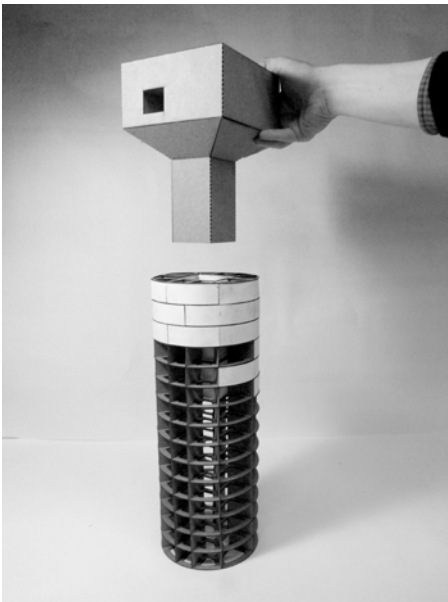

figure 5.69: Review 2 (midterm)

This sections speaks to the idea of aeration in its earliest stages and a hypoxia experimentation platform for maritime research centers inland. Algae cultivation or harvesting hasn't entered the narrative.





-- Review 2 (midterm) --

During the midterm review the critics involved were: Andrew Scott, Gediminas Urbonas, and two guest critics from the Graduate school of Design at Harvard.

Here the main focus was the iteration of the insertion. The three iterations were either masses that addressed issues of accommodation for researchers, access, and aeration connectivity. The first two are overall structures that would be inserted into the spar cylinder with all

accommodation, wet labs, dry labs, etc, within the architecture. In the end, the midterm was presented as a plug-in architecture as shown on the left as an abstract model. Each plug-in would be utilized for a specific function in the experimentation platform.

figure 5.70 - 5.82 early form iterations

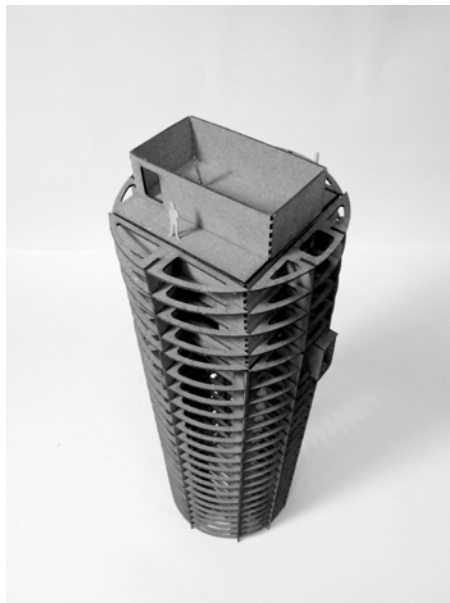
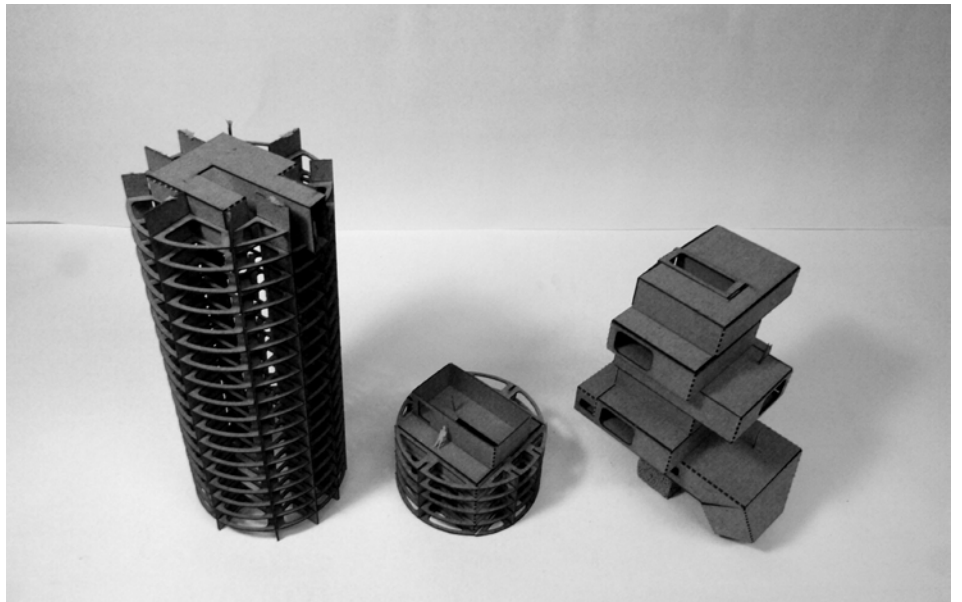

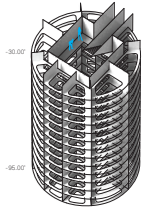

SPECTATING

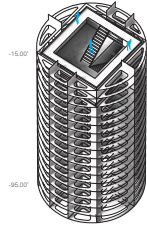

ANALYTICAL LABORATORY
ALAE CULTURE TANKS

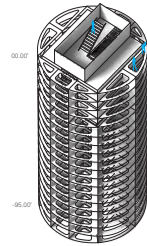

ACCESS DECK
FIELD WORK EQUIP.

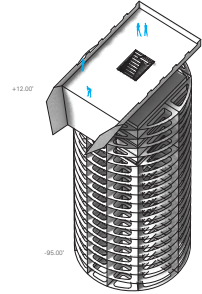

WORK STATIONS

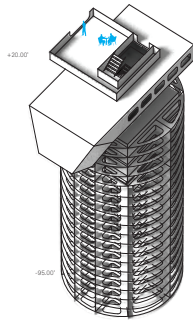

DINING

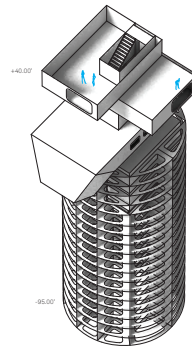
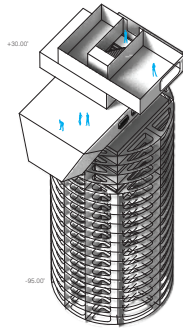

LODGING

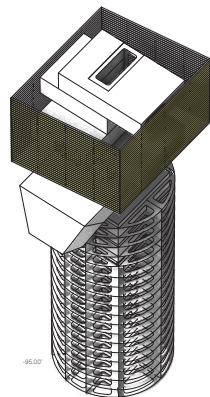
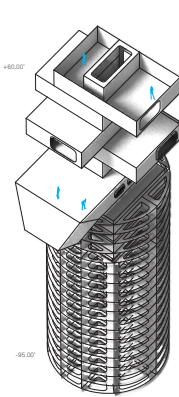
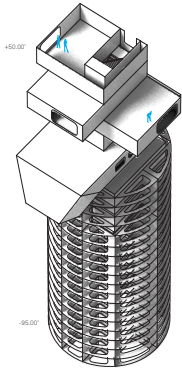

ENERGY HARVESTING

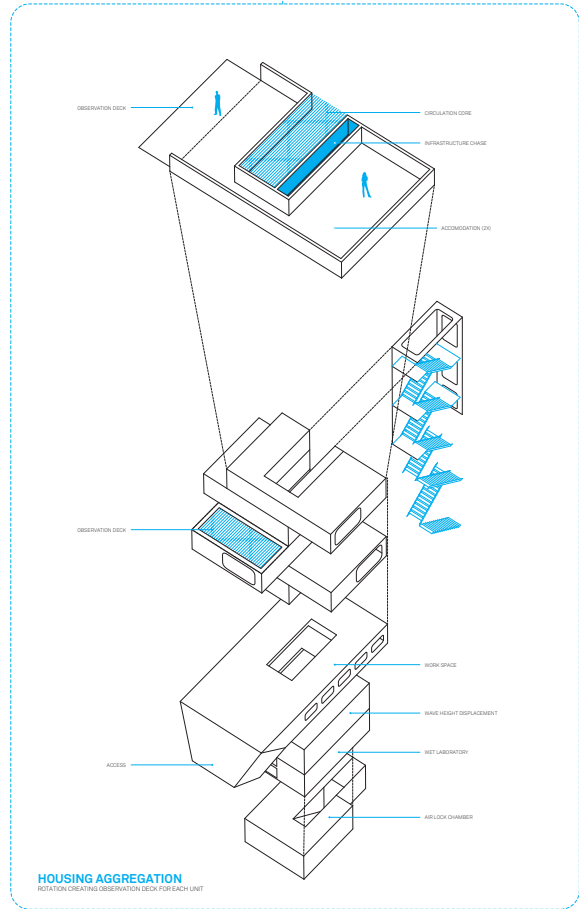
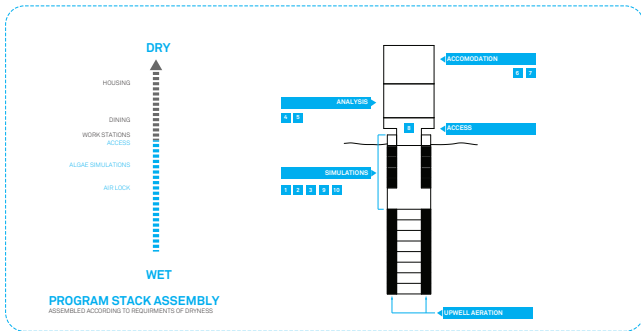

MARINE RESEARCH PROGRAM (TYP.)



1 ALGAE CULTURE TANKS
 WATER TANKS: CULTURE BIVALVE LARVAE AND MICRO ALGAE WITH VARIOUS TEMPERATURES, SALINITY, AND FILTRATION PARAMETERS

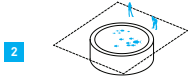

2 SEAWATER QUARANTINE
 SEAWATER QUARANTINE SYSTEM PROVIDING THE CAPABILITY TO CONDUCT WORK ON NON-INDIGENOUS SPECIES (20' DIAMETER MIN)

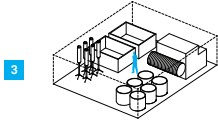

3 FIELD WORK EQUIPMENT
 INCLUDING: ACOUSTIC DOPPLER VELOCIMETER, DREDGE, OTTER TRAWL, AND PLANKTON NET

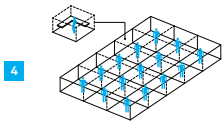

4 WORK STATIONS
 GENERALLY SEAWATER RESEARCH STATIONS PROVIDE 15 WORK STATIONS

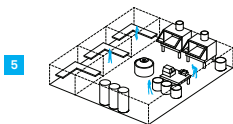

5 ANALYTICAL LABORATORY
 WORK STATION FO 3, EQUIPPED WITH FUME HOOD, FLOURIMETER, SPECTROPHOTOMETER, CENTRIFUGE, BALANCES, AND WATER PURIFICATION SYSTEM

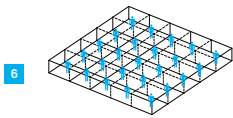

6 LODGING
 TYPICALLY RESEARCH CENTERS PROVIDE TEMPORARY HOUSING FOR 40-50 PEOPLE.

+



ADDITIONAL PROGRAMS

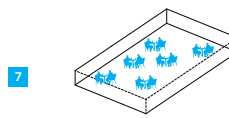

7 DINING
 THE COMPLEX WILL OFFER THE FOOD HARVESTED WITHIN THE AREA WHEN THE ARCHITECTURE ACTS AS A NOMADIC ECOLOGY.

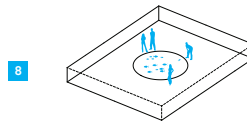

8 LEISURE
 DINING AND LEISURE SPACE WILL BE DIRECTLY ASSOCIATED WITH THE LODGING AREA.



9 SPECTATING
 SPECTATING UPON MARINE ACTIVITY WILL BE SPLIT INTO TWO GROUPS. ONE FOR THE TOURISM WITHIN THE LODGING SPAN AND ONE UNDER THE ANALYSIS SPAN FOR SCIENTIFIC RESEARCH.



10 ALGAE COLLECTION
 ALGAE BLOOMS WOULD BE COLLECTED BY THE ARCHITECTURE AS A MODE OF ENERGY GENERATION: BIODIESEL.

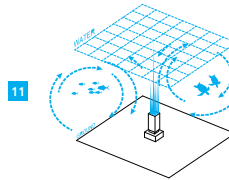

11 UPWELL AERATION
 WATER WOULD BE CIRCULATED BY UPWELLING BOTTOM LAYER NUTRIENTS WITH OXYGENATED SURFACE LAYERS, BREAKING THE THERMOCLINE BENEFITING THE MARINE FOOD CHAIN



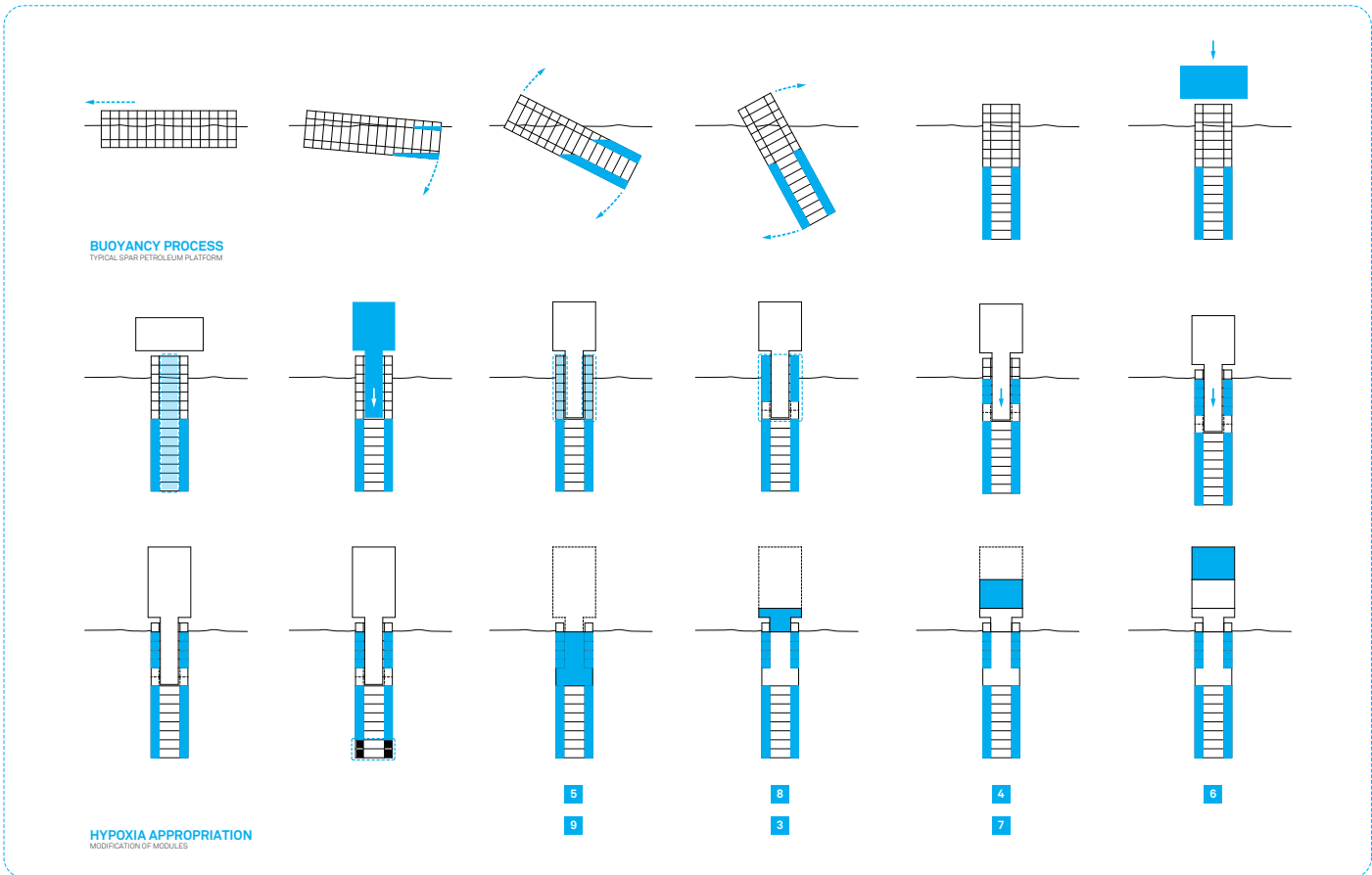
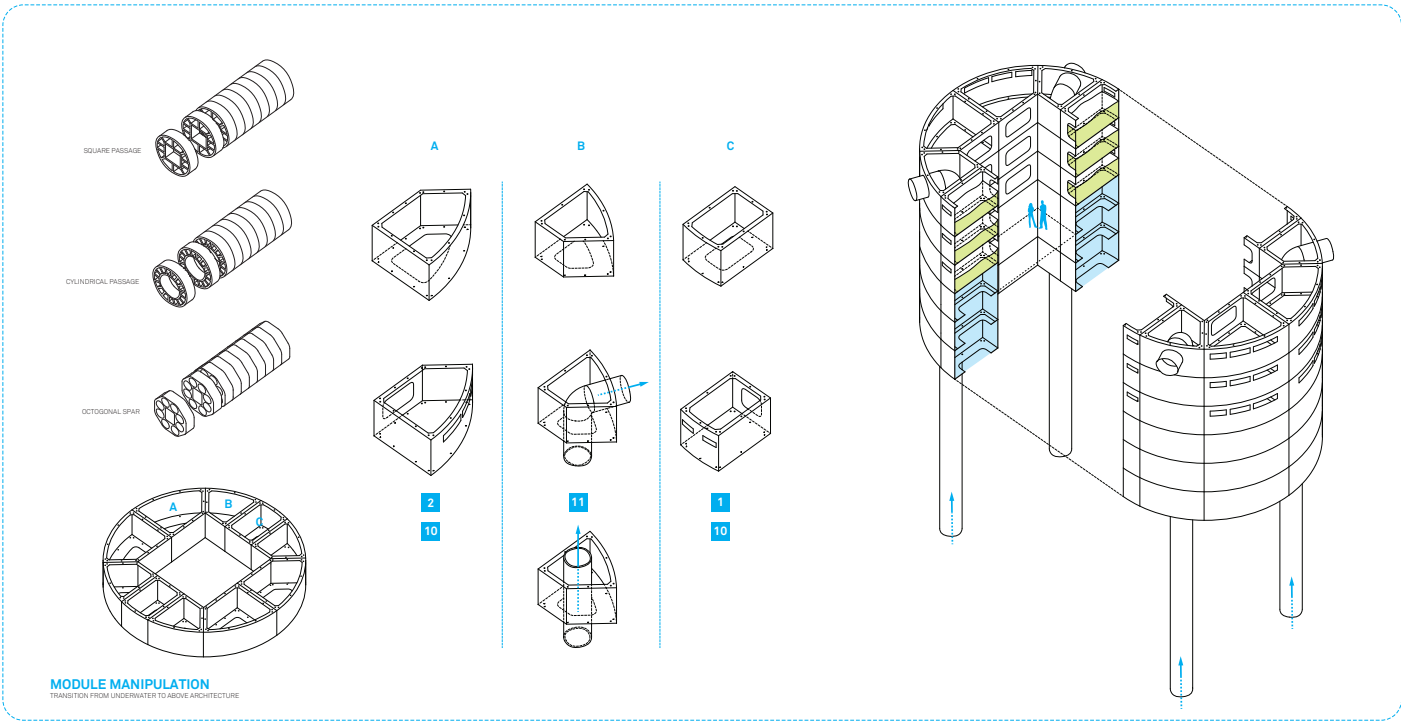

figure 5.83 - 5.92 Review 2(midterm)

The images on the past two spreads are from the midterm review looking at different levels of the structure, techniques of buoyancy, modalities of collecting algae, as well as physical models of the final architecture.



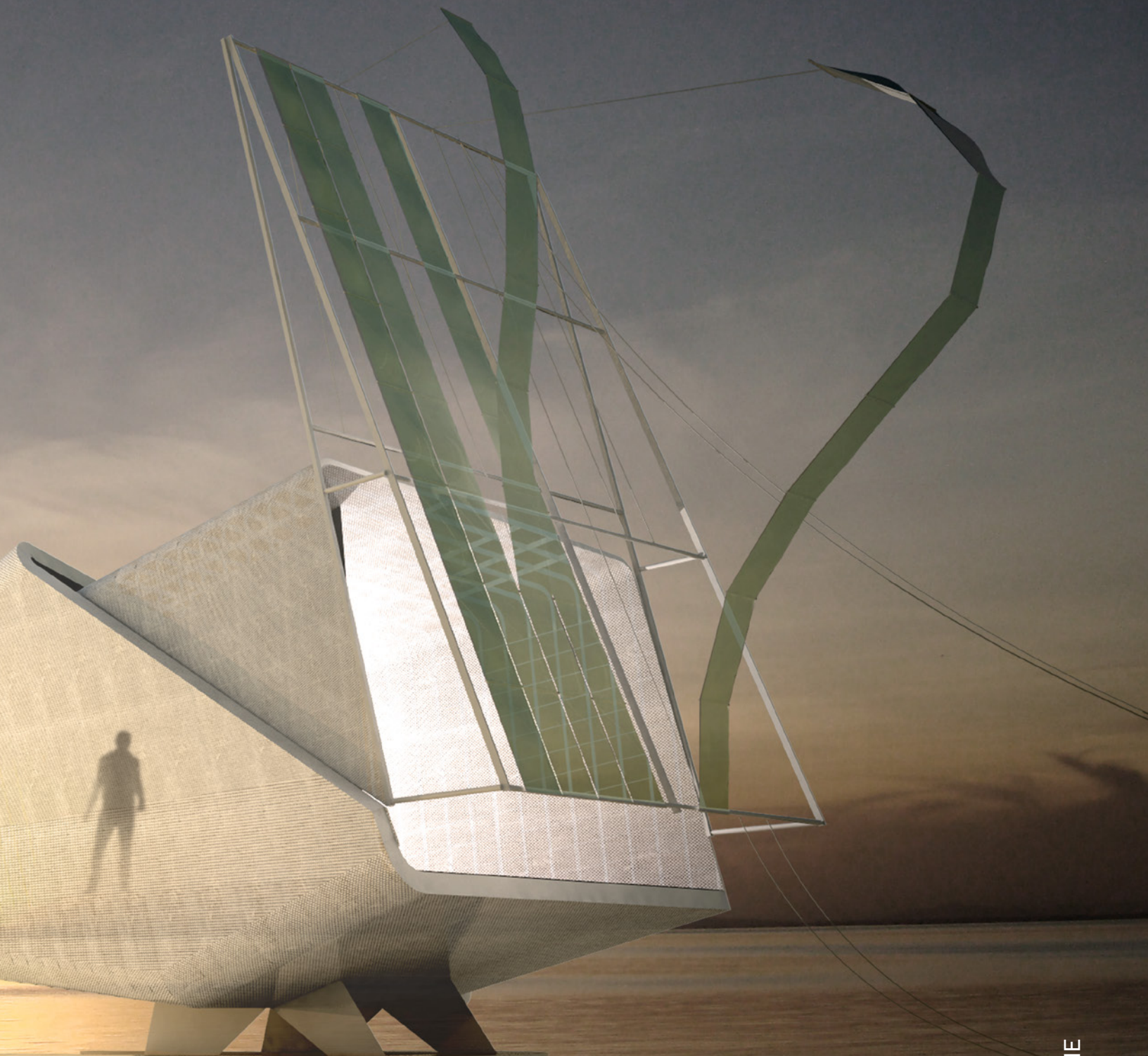
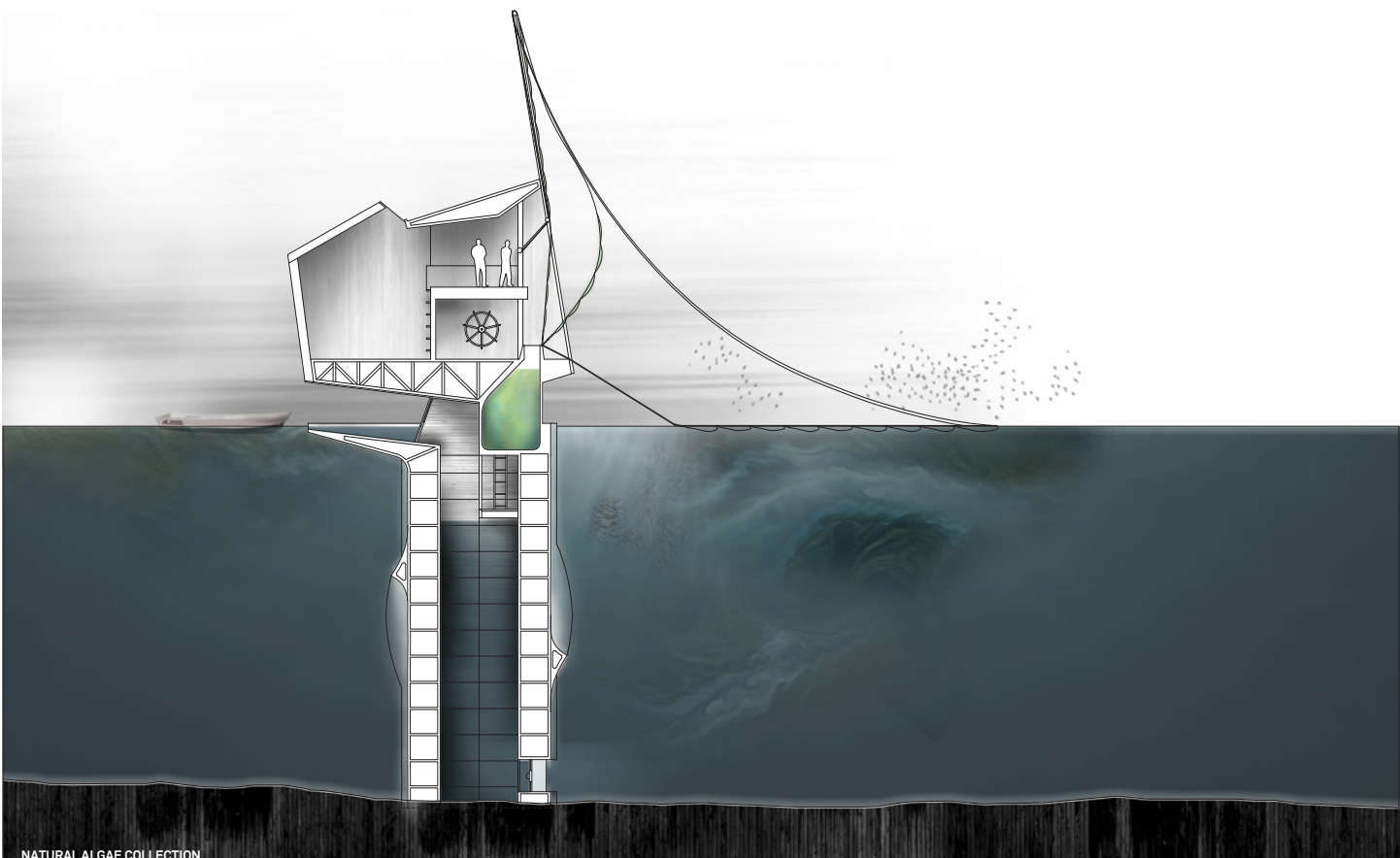
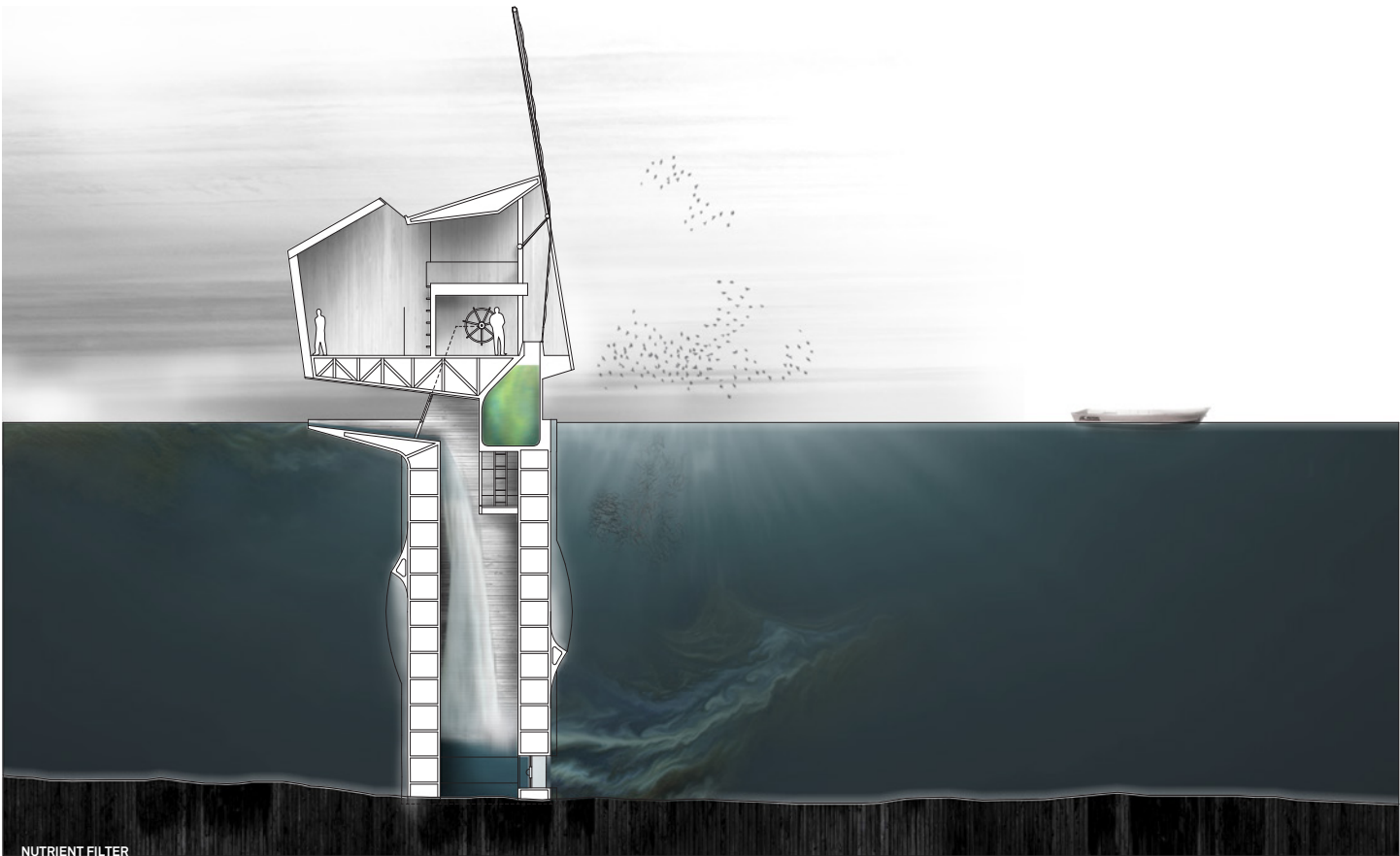
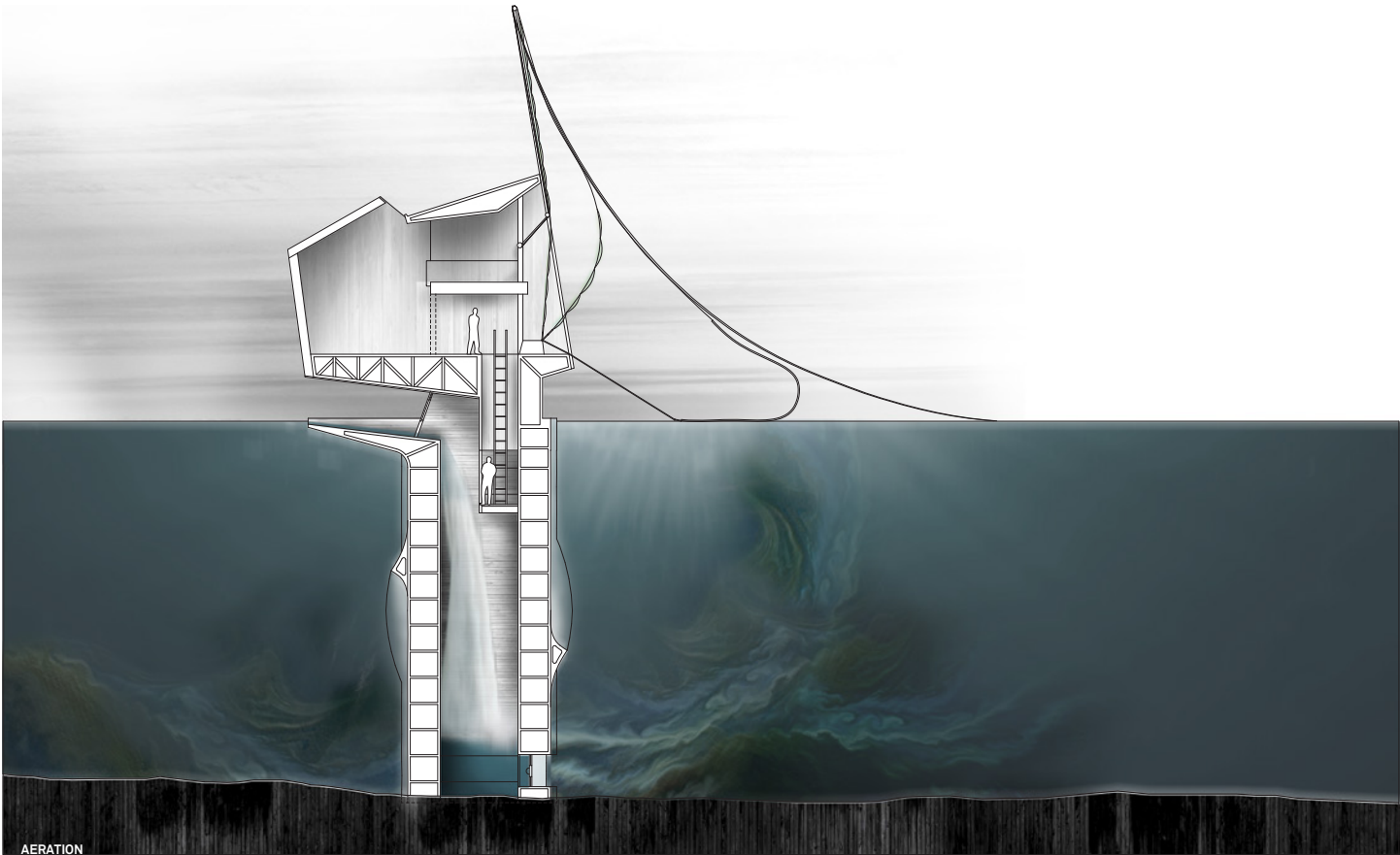

figure 5.93 - 5.101: drawings following the midterm

After the midterm review, the design began exploring a smaller scale satellite platform with a more complex geometry and a systems of shells that generate a hull inserting into the spar. These decisions came with more research in hypoxia.





AERATION

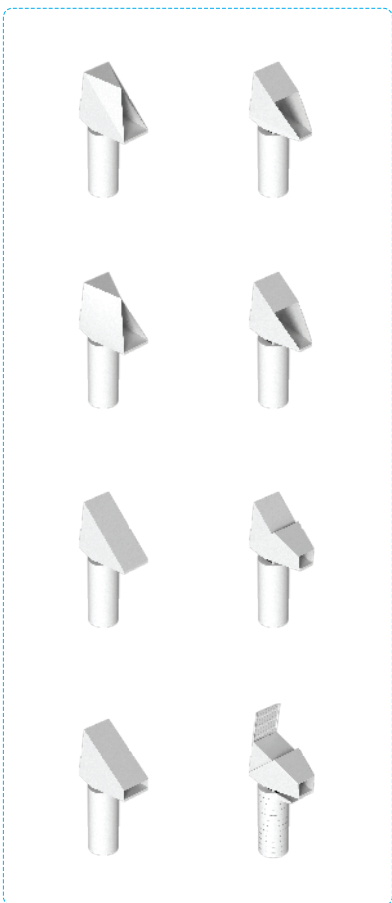

NOTES:

1. Accomodation shell
2. Experimentation shell
3. Living deck
4. Algae collection platform
5. Trolley net tie-back
6. Net & pully system structure
7. Algae trolley net
8. Bio-mass storage
9. Buoyancy modules
10. Aeration inlet
11. Active pump for aeration outlet
12. Aeration control room

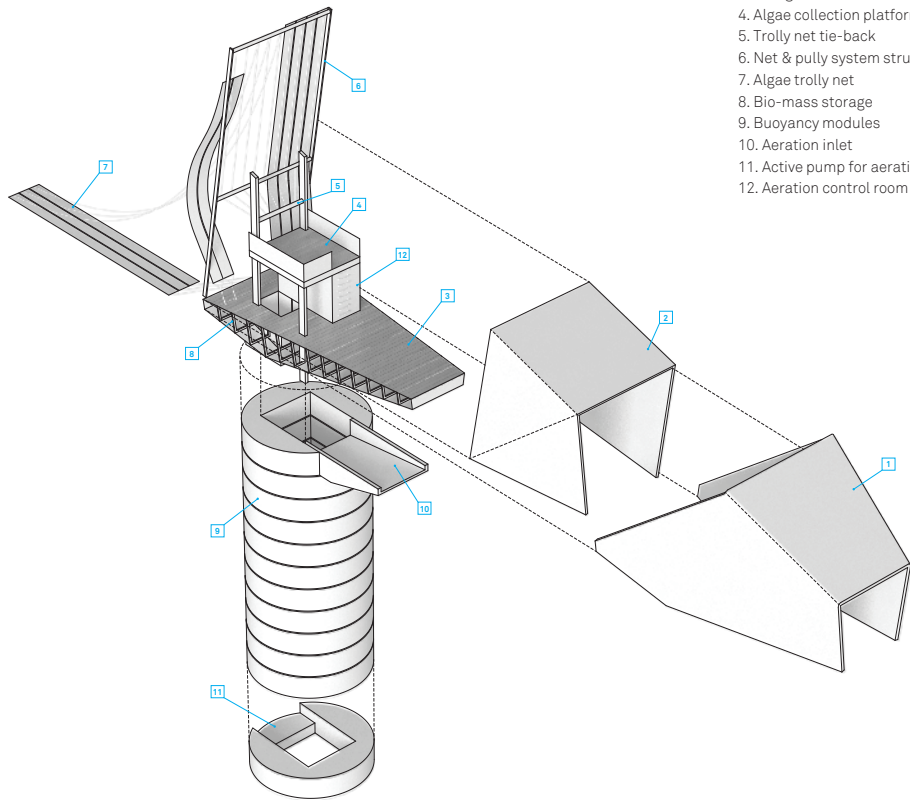

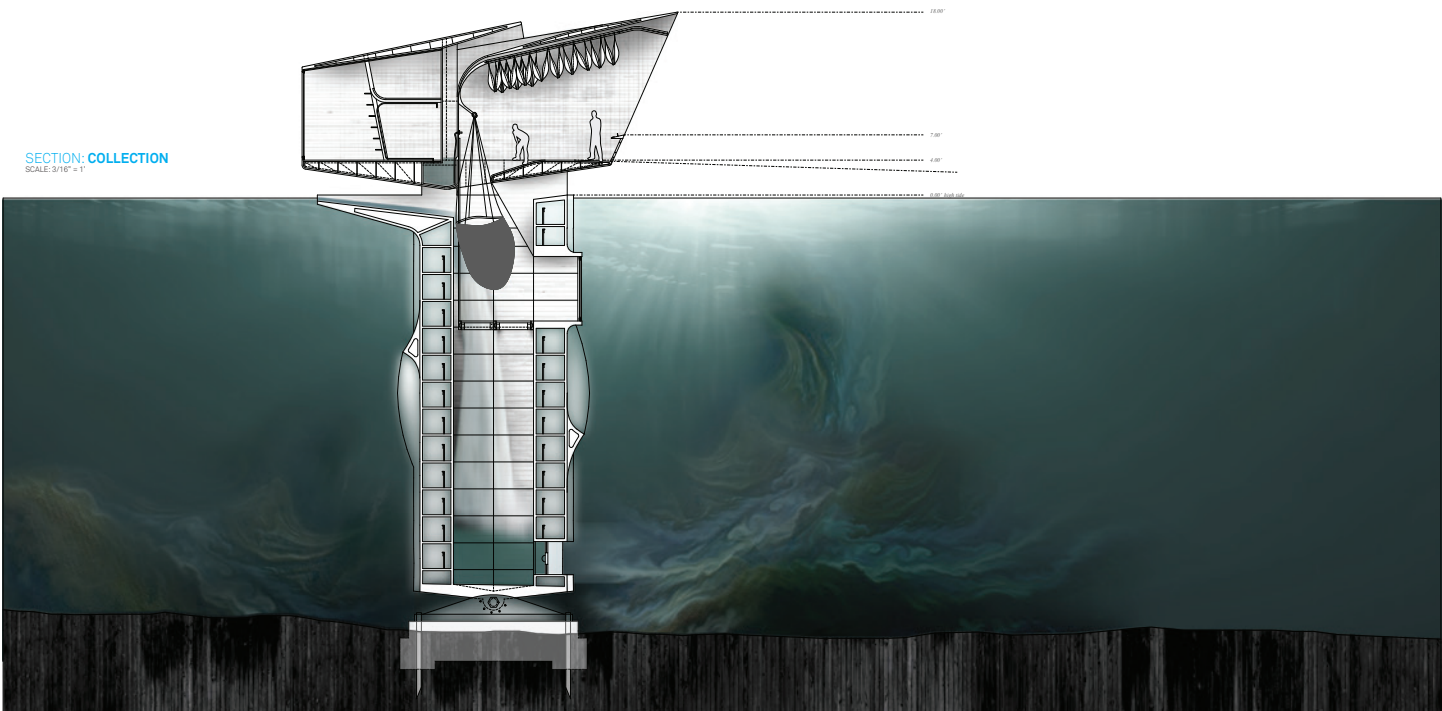
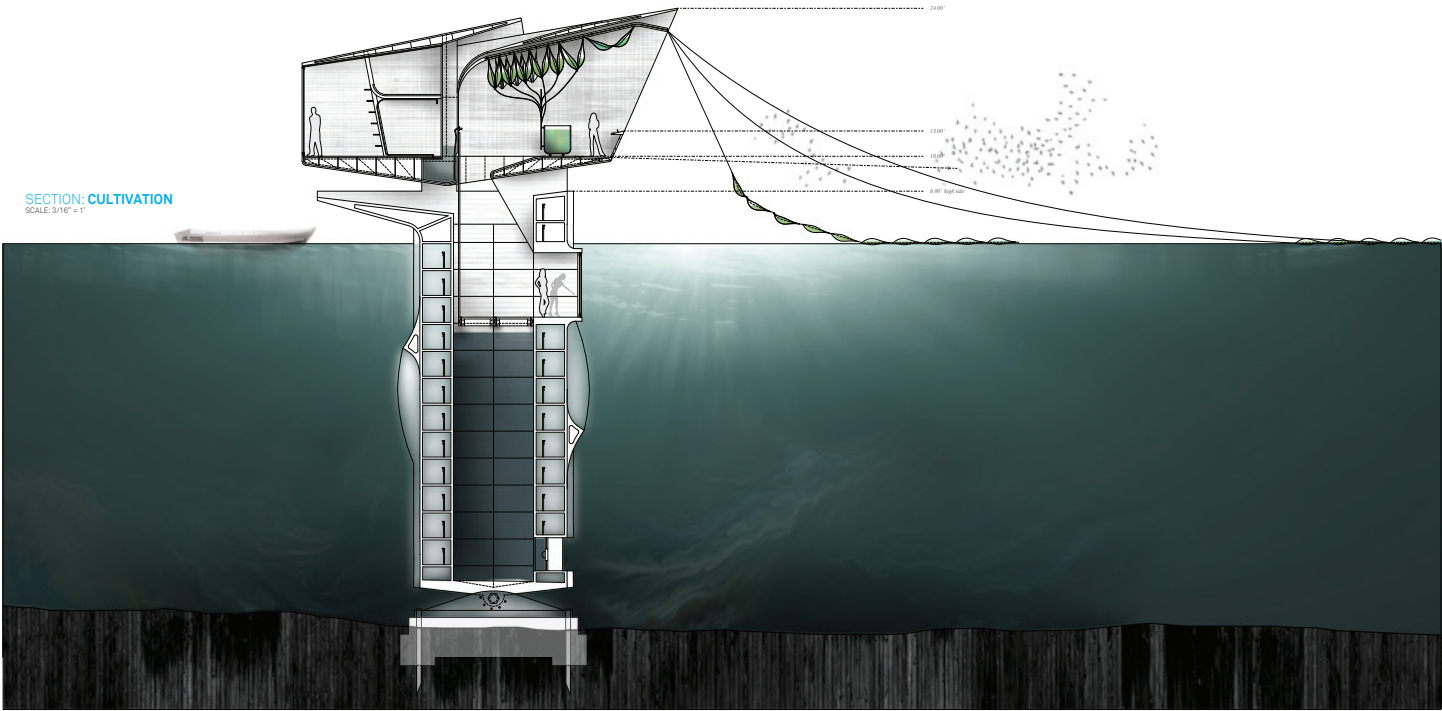

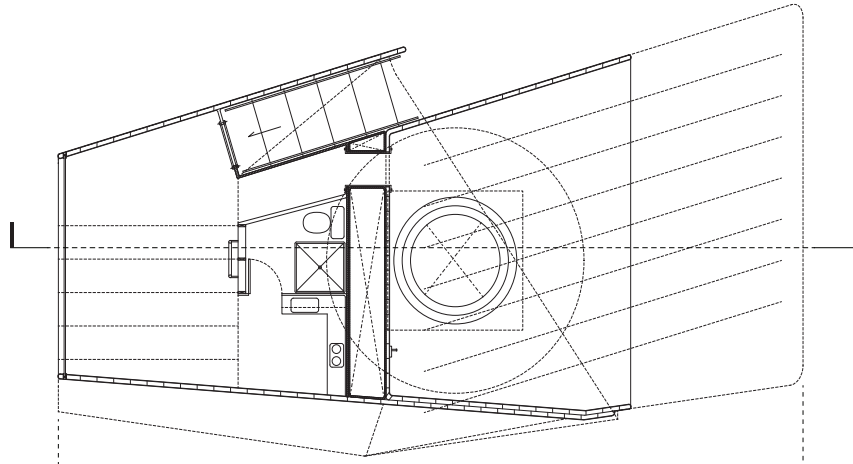

Plan
scale: 1/2" = 1'

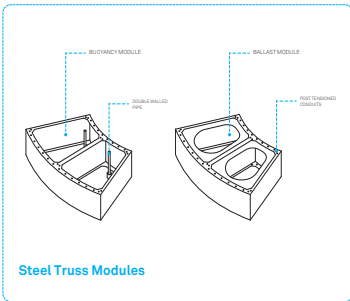
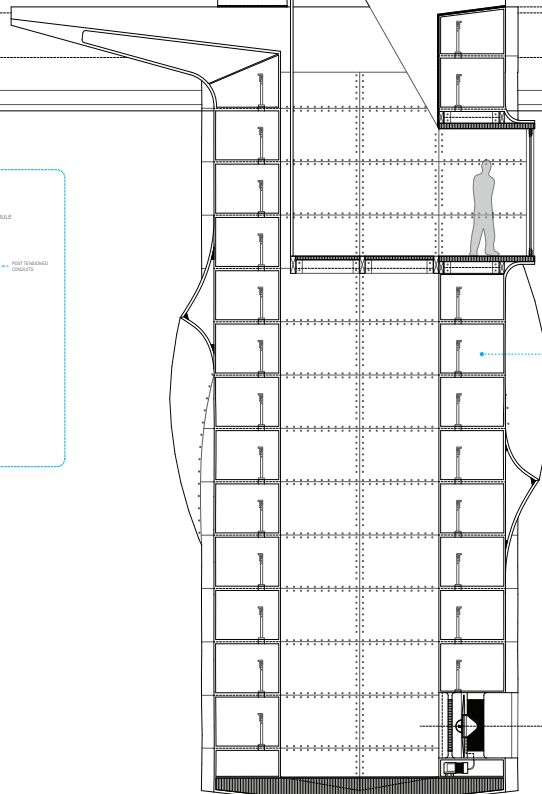
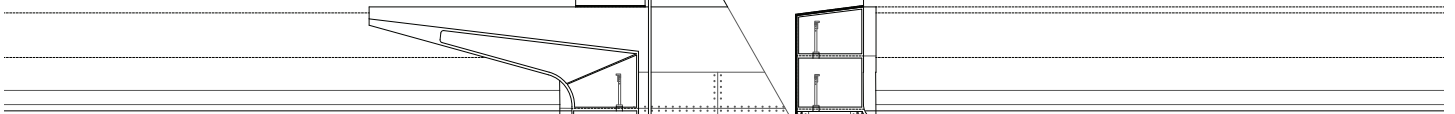
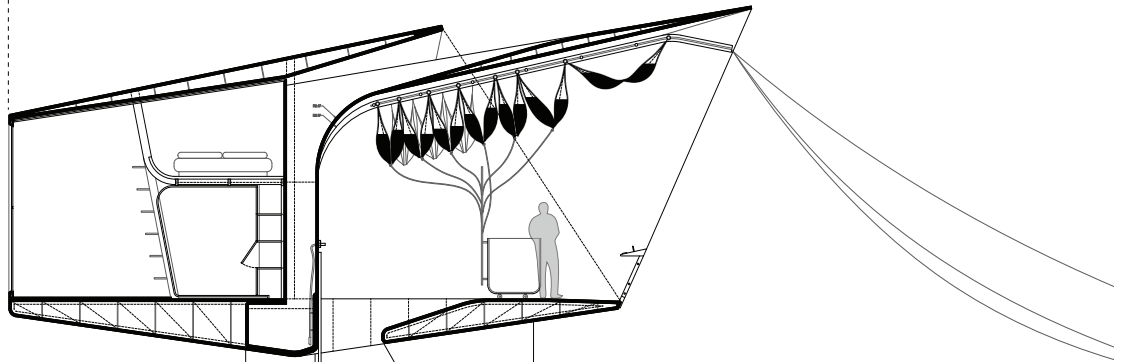

Steel Truss Modules

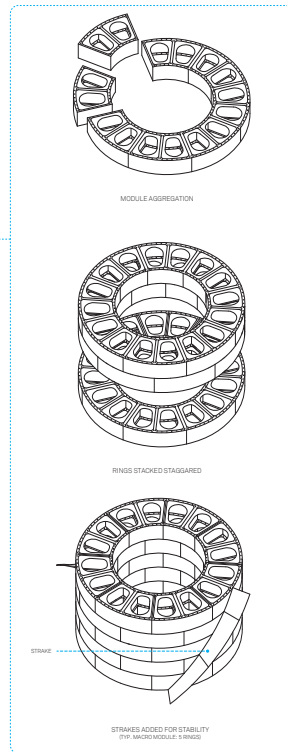

Section
scale: 1/2" = 1'

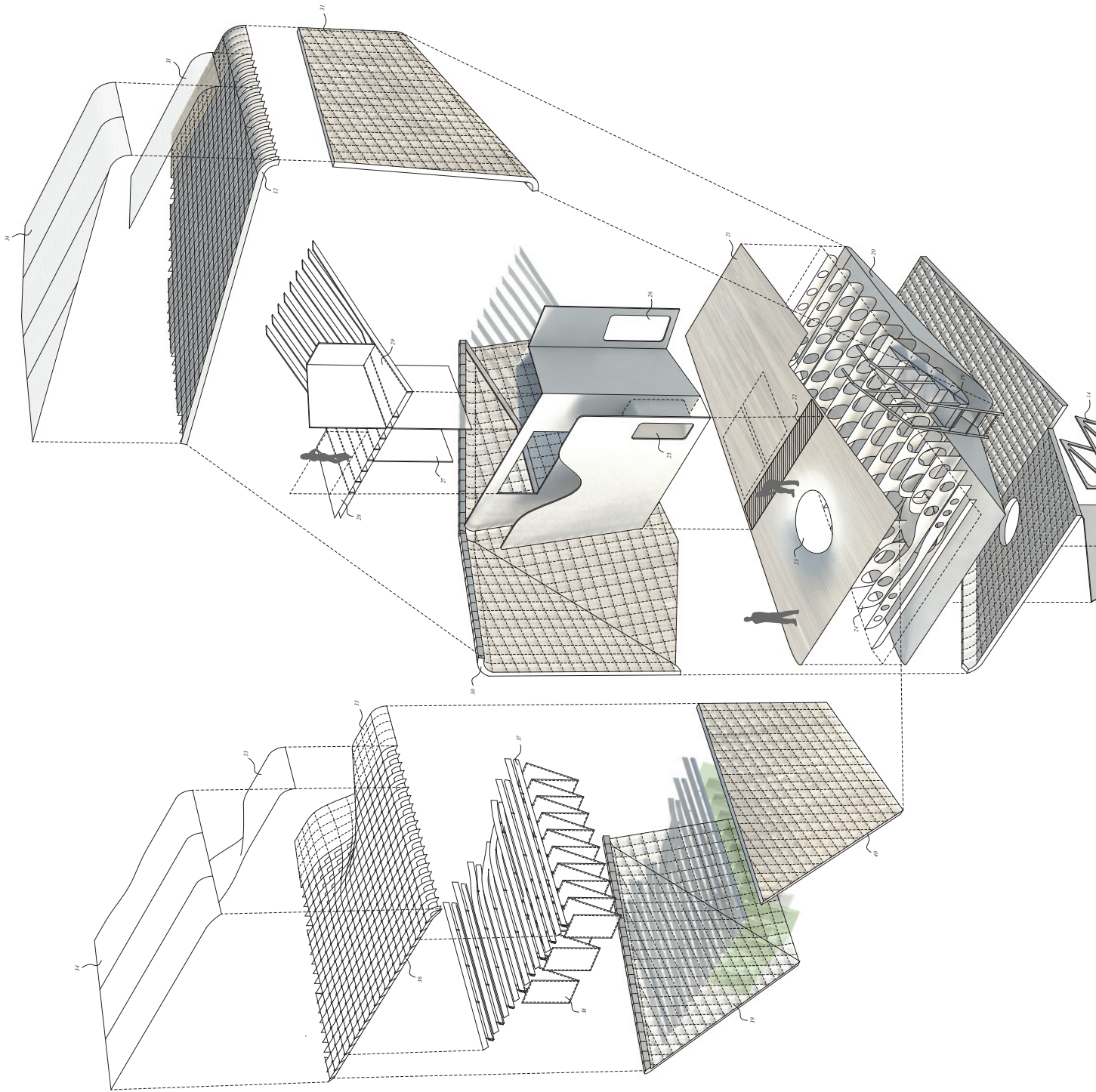

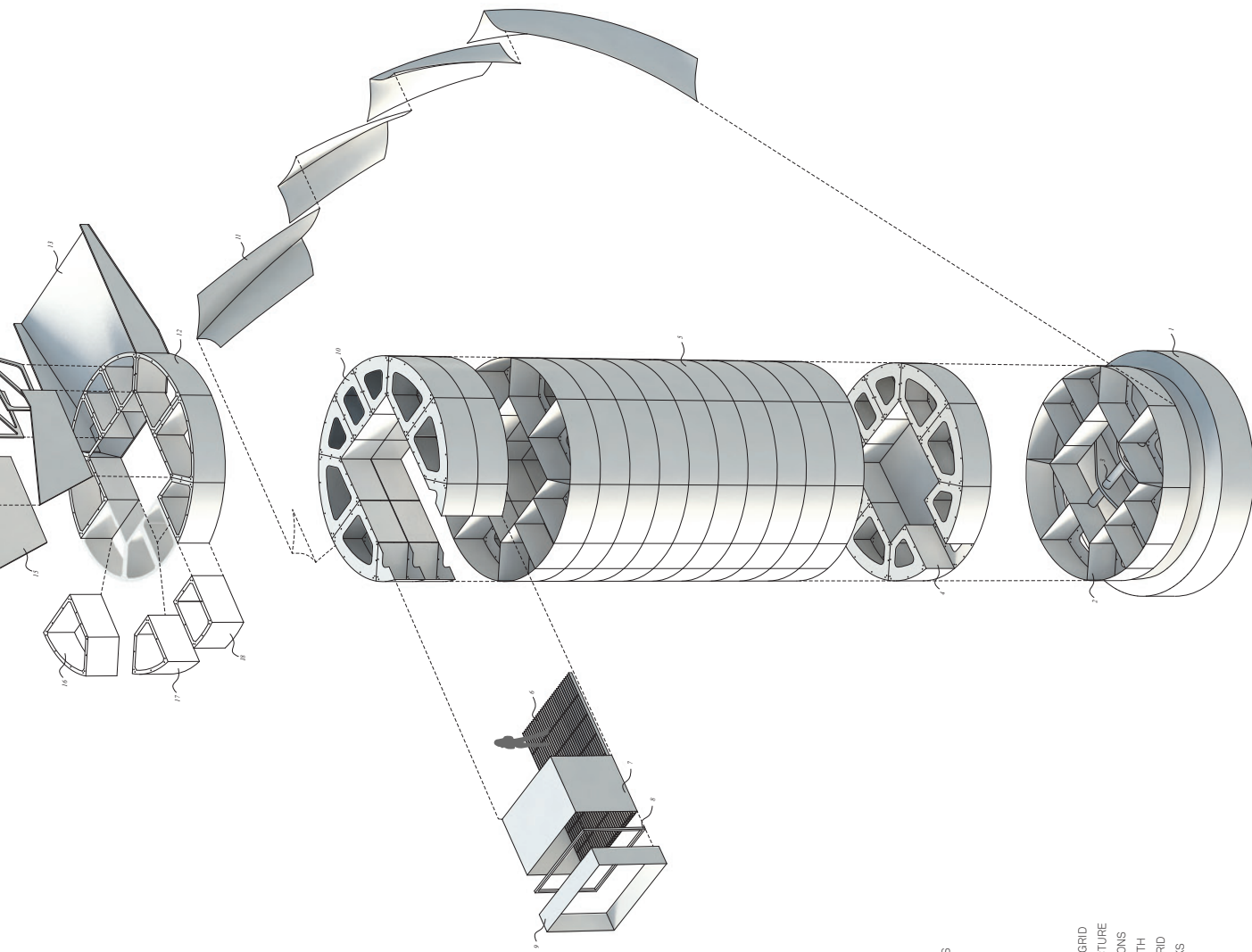

NOTES:

- 1. ANCHOR FOUNDATION
- 2. BASE BALLAST: PULLVERIZED IRON ORE
- 3. SPAR CONNECTION PIVOT
- 4. ACTIVE PUMP SECTION
- 5. BALLAST/BUOYANCY MODULES (TYP.)
- 6. METAL GRATING PLATFORM
- 7. UNDERWATER SPECTATOR
- 8. AIR TIGHT MULLION SYSTEM
- 9. WATER SEAL CAP
- 10. UNDERWATER ROOM MODULES
- 11. STRAKE
- 12. TOP CONNECTOR MODULES
- 13. ALGAE HARVESTING SHOOT
- 14. INNER CONNECTOR
- 15. OUTER CONNECTOR
- 16. MODULE: LARGE
- 17. MODULE: CORNER
- 18. MODULE: MIDDLE
- 19. ACCESS STAIR
- 20. HULL SHEATHING
- 21. MAIN DECK
- 22. WATER COLLECTION WALL
- 23. ALGAE NET ACCESS
- 24. HULL/DECK STRUCTURE
- 25. PRODUCTION DECK ACCESS
- 26. ENTRANCE
- 27. RESTROOM
- 28. LOFT (2 BED)
- 29. STORAGE
- 30. LEFT COMPOSITE WALL
- 31. RIGHT COMPOSITE WALL
- 32. LIGHT WEIGHT ALUMINIUM GRID
- 33. CLOTH DRAPE OVER STRUCTURE
- 34. FIBER GLASS CLOTH SECTIONS
- 35. EPOXY RESIN COAT ON CLOTH
- 36. BACK SHELL ALUMINIUM GRID
- 37. ALGAE CULTIVATION TRACKS
- 38. ALGAE CULTURE BAGS
- 39. BACK SHELL LEFT
- 40. BACK SHELL RIGHT

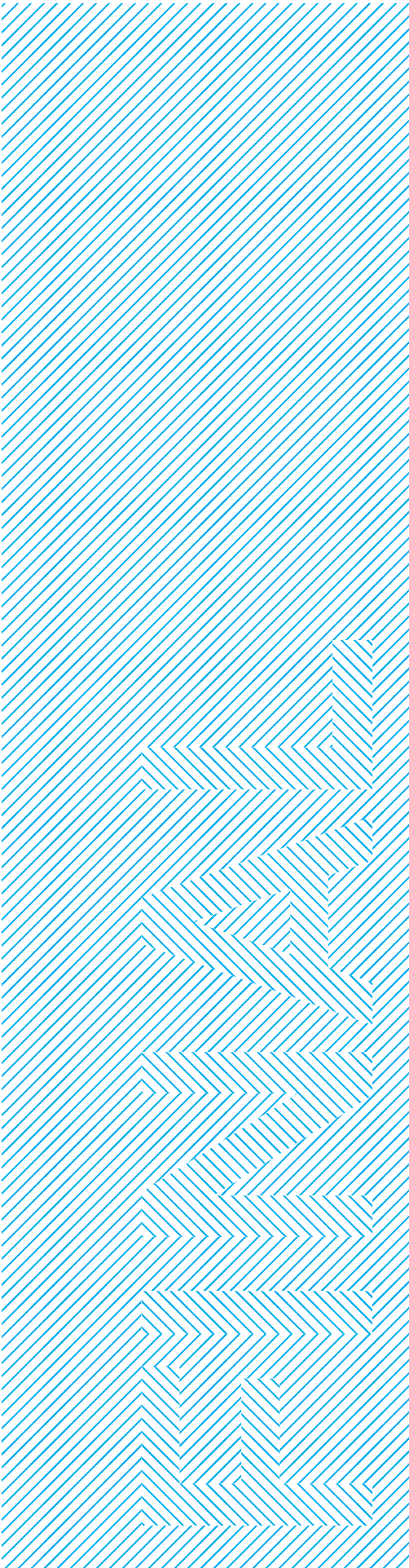

Dead Zone: Final

The remainder of this book reveals the final outcome or layout for the last presentation of M.Arch Thesis final review on December 19, 2013 in E14-674(media lab). During session 4 from 12:15 - 1:10 in section C4 the following critics participated in the review:

Andrew Scott
Anton Garcia-Abril
Gediminas Urbonas

----- Thesis **Committee**

Jose Selgas
Sheila Kennedy
Mark Goulthorpe

----- Guest **MIT Critics**

Jill Desimini
David Lewis
Amanda Lawrence
Lindy Roy

----- Visiting **Critics**



AGRICULTURE RUNOFF

Runoff from agricultural fields carries fertilizers and pesticides into the Gulf of Mexico. This runoff is a major source of nutrients that fuel the growth of algae and other organisms in the Gulf.

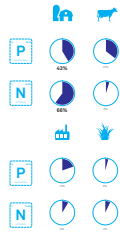
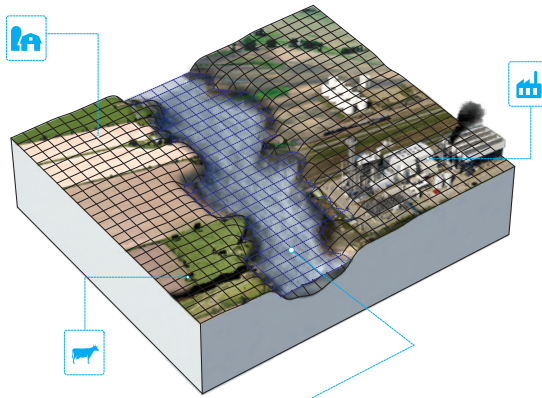

FLOW OF NUTRIENTS INTO GULF OF MEXICO

The nutrients from agriculture, industry, and urban areas flow into the Gulf of Mexico, where they fuel the growth of algae and other organisms.

N
Nitrogen

P
Phosphorus

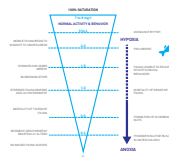
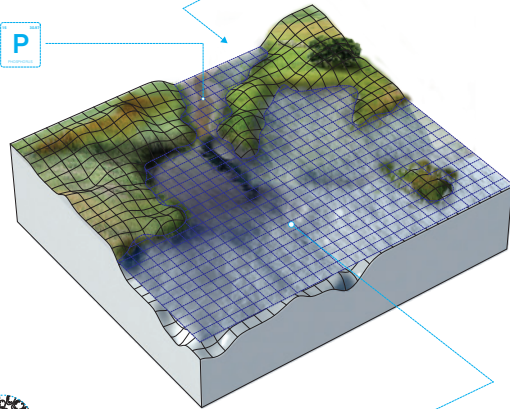

CREATION OF HYPOXIA

The hypoxic zone in the Gulf of Mexico is a result of the decomposition of algae and other organisms that die in the water column.

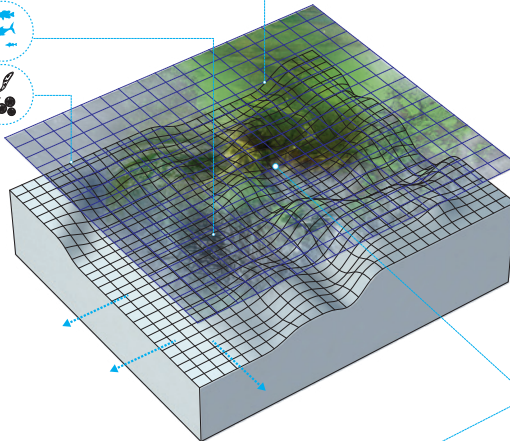

O
Oxygen

oxygen
depletion
anoxia
algae collection
stratification

MITIGATION TECHNIQUES

Strategies to reduce nutrient runoff and improve water quality in the Gulf of Mexico include: reducing fertilizer use, improving agricultural practices, and treating wastewater.

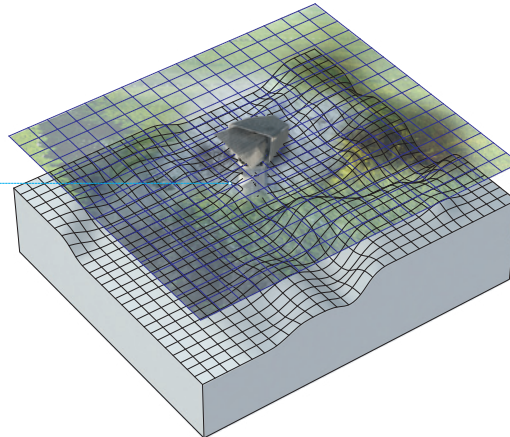

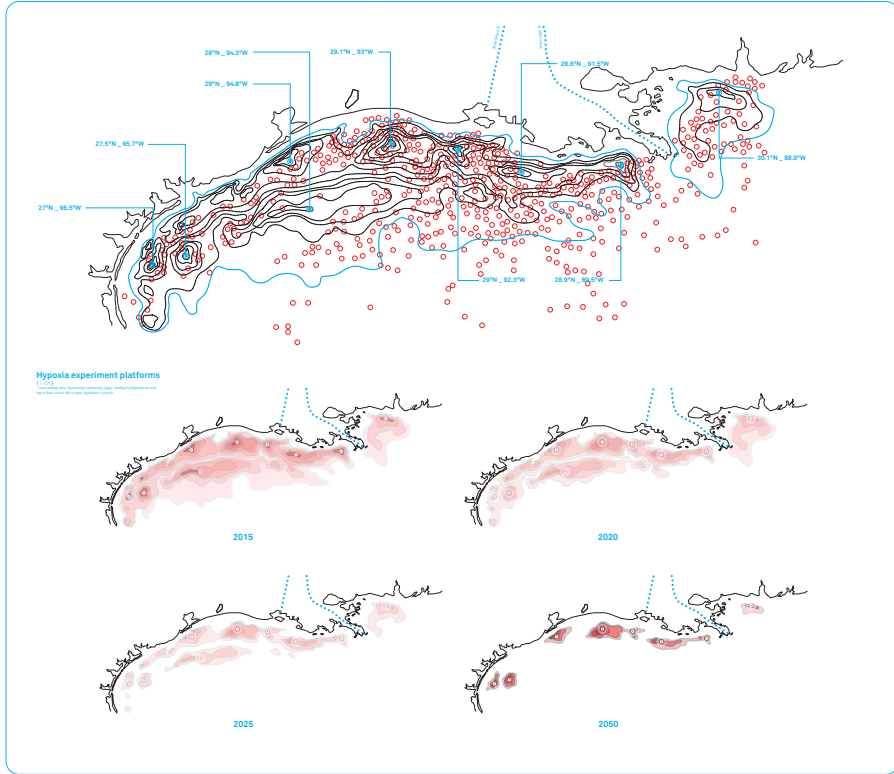
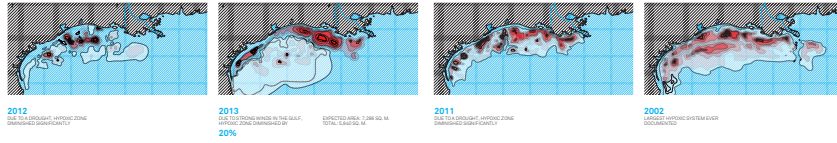

Maritime research facilities

- ALGAE CULTURE TANKS**
WATER TANKS CULTIVATE ALGAE AND OTHER MARINE LIFE UNDER VARYING TEMPERATURES, SALINITY, AND FILTRATION PARAMETERS
- SEAWATER QUARANTINE**
QUARANTINE QUARANTINE SYSTEM PROVIDING THE CLEANEST TOXICOLOGY SYSTEM AVAILABLE FOR RESEARCH PURPOSES OF QUARANTINE WATER
- FIELD WORK EQUIPMENT**
WATER-SAMPLE COLLECTOR, SALINITY, TEMPERATURE, OXYGEN, OTHER TRAVEL, AND PLANNING

Additional programs

- WORK STATIONS**
RESEARCHER OPERATES REMOTE-OPERATED VEHICLES PROVIDES 15 WORK STATIONS
- ANALYTICAL LABORATORY**
WATER SYSTEMS FOR MONITORING WATER QUALITY, FLUORIMETER, SPECTROPHOTOMETER, OPTIC FLOW, AND WATER PURIFICATION SYSTEM
- ALGAE COLLECTION**
ALGAE SAMPLES WILL BE COLLECTED BY THE ARCHITECTURE AS A MESH OF ENERGY GENERATING BARRIERS
- UPWELL AERATION**
WATER WOULD BE CIRCULATED IN UPWELLING BOTTOM WATER MIXED WITH OXYGENATED SURFACE WATER THROUGH THE TRAPPING DEVICE BENEFITING THE MARINE FOOD CHAIN

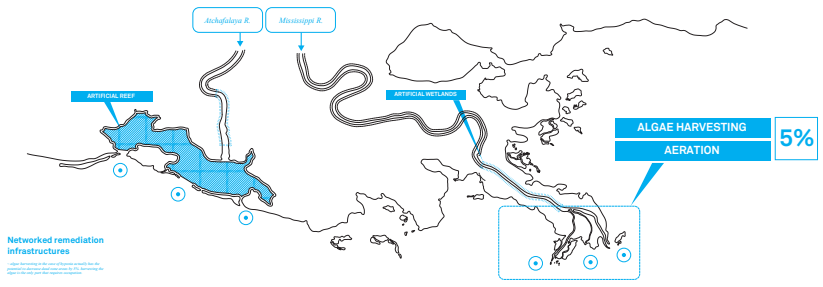

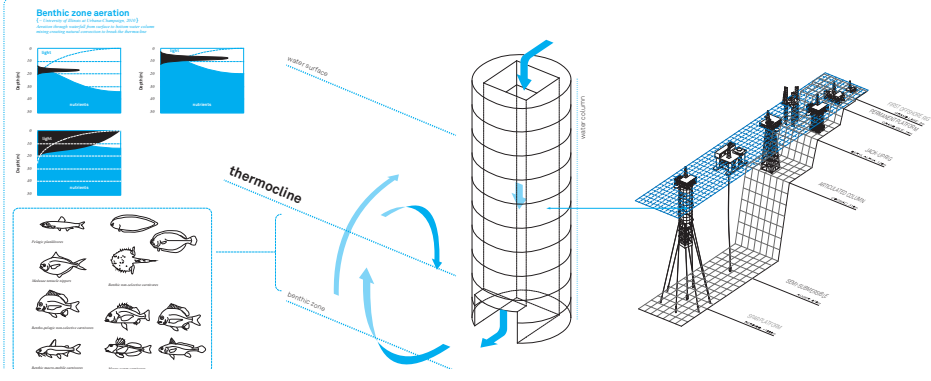
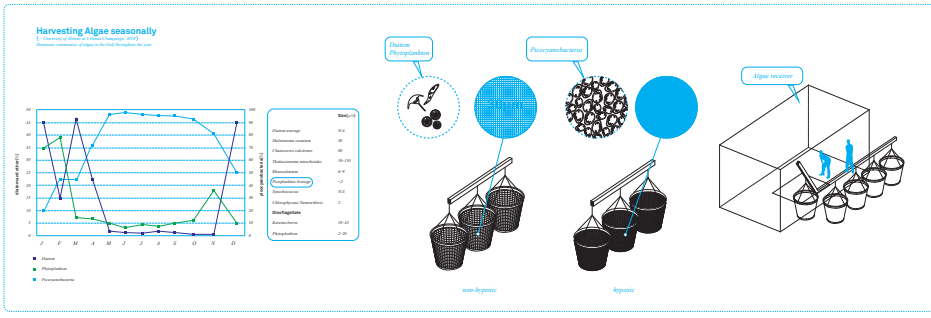
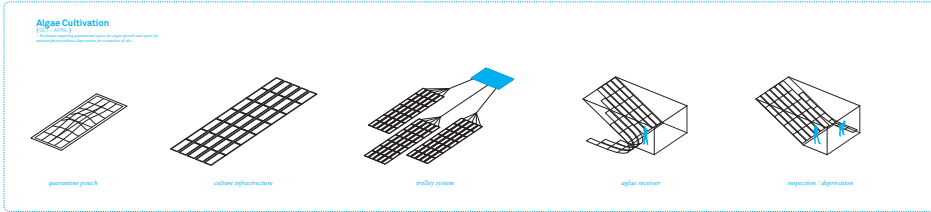
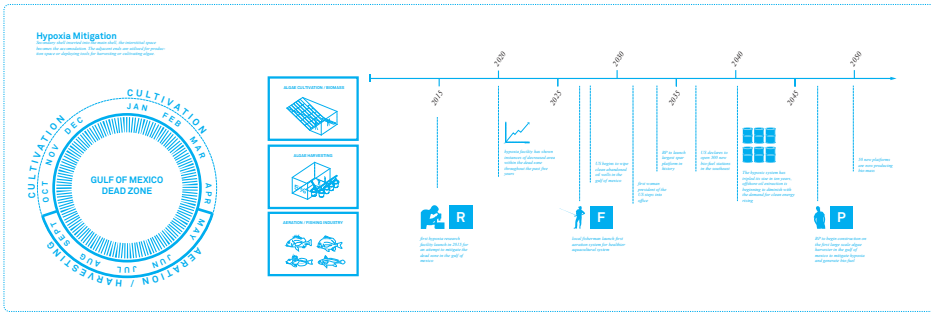
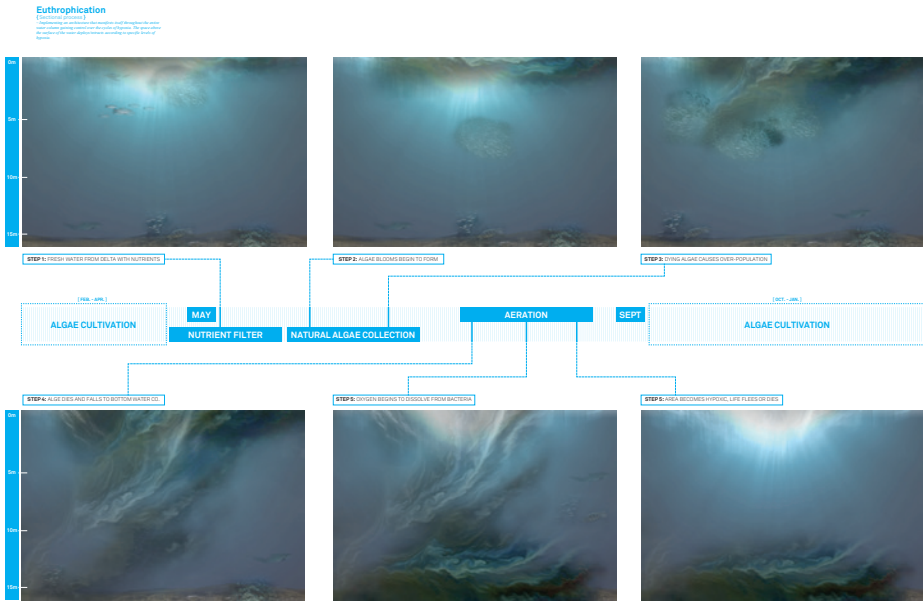

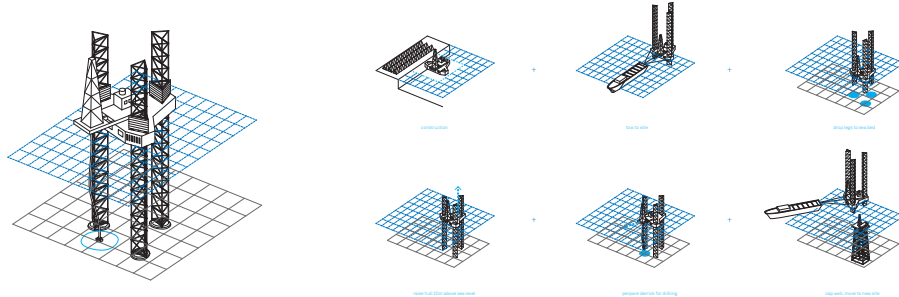

PLATFORM: JACK-UP RIG
ASSEMBLY / FORCE ORDER / BUOYANCY

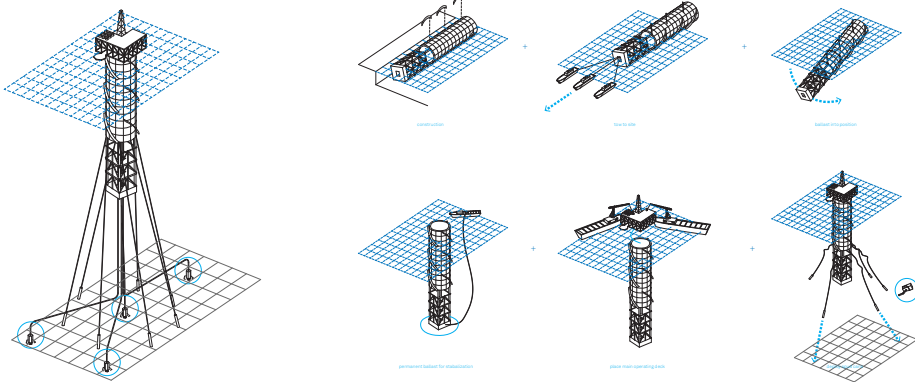

PLATFORM: SPAR
ASSEMBLY

PLATFORM: SPAR HYPOXIA
ASSEMBLY / FORCE ORDER / BUOYANCY

This section provides a detailed assembly sequence for the Spar Hypoxia platform. It includes:

- Force order diagrams showing the sequence of component assembly.
- Three icons representing environmental forces: Sun (top left), Wind (top middle), and Waves (top right).
- A series of diagrams showing the platform being jacked up and then subjected to various forces.
- A final diagram showing the platform fully assembled and jacked up.

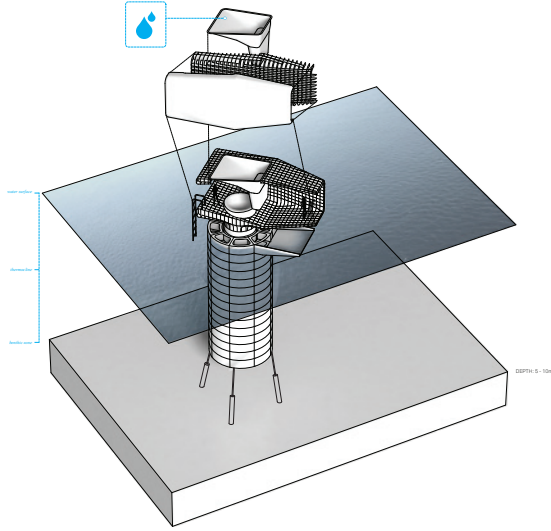

[2015]
R PLATFORM TYPE:
 RESEARCH & DEVELOPMENT
 IN HYPOXIA
 SOUTHWEST PASSAGE

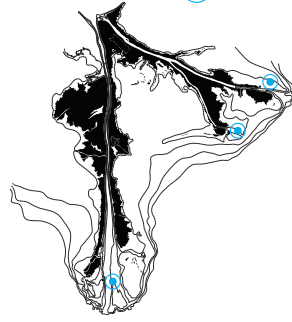

LOCATION: DELTA OUTLET

MAKES THE HARBOR MORE SUITABLE FOR SHIPING AND
 APPROXIMATES THE ACTUAL CONTACT. THE PLATFORM
 WOULD BE USED AS A "RESEARCH AND DEVELOPMENT"
 ZONE & INCLUDING OFFICE, STORAGE, CENTER FOR
 ACCOMMODATION OFFICES, RESEARCH VESSEL, TRUCK

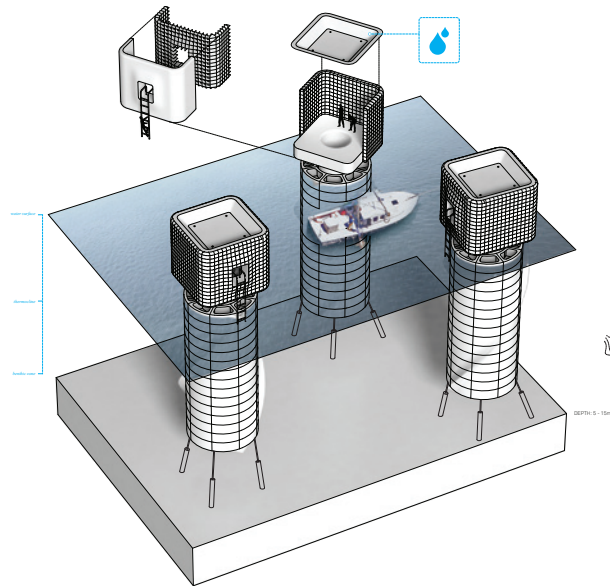

[2020]
F PLATFORM TYPE:
 FISHING BUNGALOW
 SOUTHWEST PASSAGE

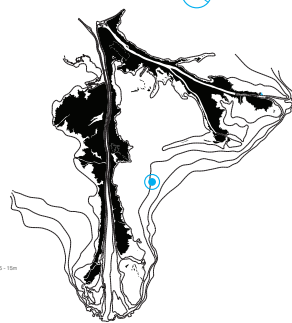

LOCATION: INNER SHELF

A SERIES OF PLATFORMS CLUSTERED TO CREATE
 A HUB FOR LOCAL FISHERIES. THE HUB WOULD INCLUDE FISHING
 NETS FOR LOCAL FISHERMEN TO STORE EQUIPMENT AND
 FOR OTHER LIGHT EQUIPMENT OF DOMESTIC
 WATERS.

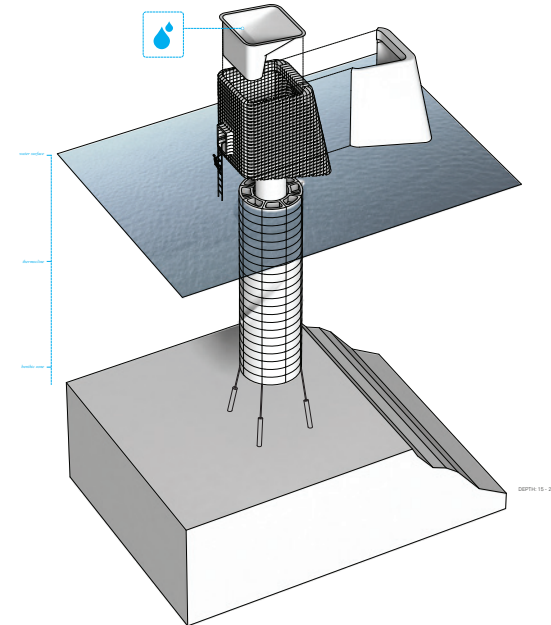

[2050]
P PLATFORM TYPE:
 PRODUCTION
 SOUTHWEST PASSAGE

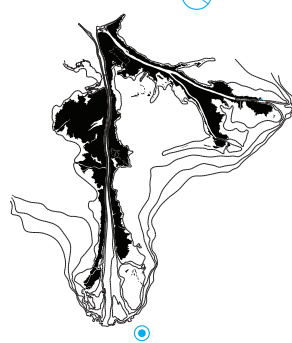

LOCATION: OUTER SHELF

THIS PLATFORM WOULD BE USED FOR LARGER SCALE
 TYPES OF ALGAE COLLECTION AND CULTIVATION MAKING
 USE OF HARVESTING FROM THE OUTER SHELF. THE ALGAE
 DURING THE GROW-UP ALGAE GROWING IN DIFFERENT
 DEPTHS WOULD BE USED BY LOCAL MARKET
 MAKERS IN THE NEAR FUTURE

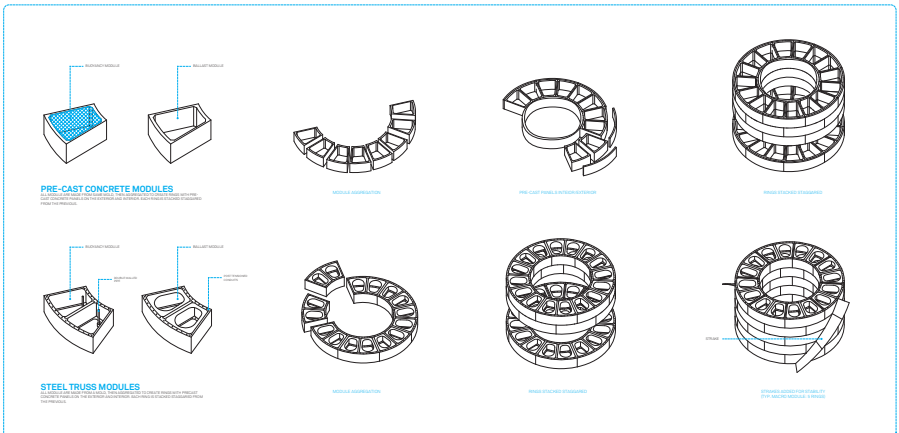
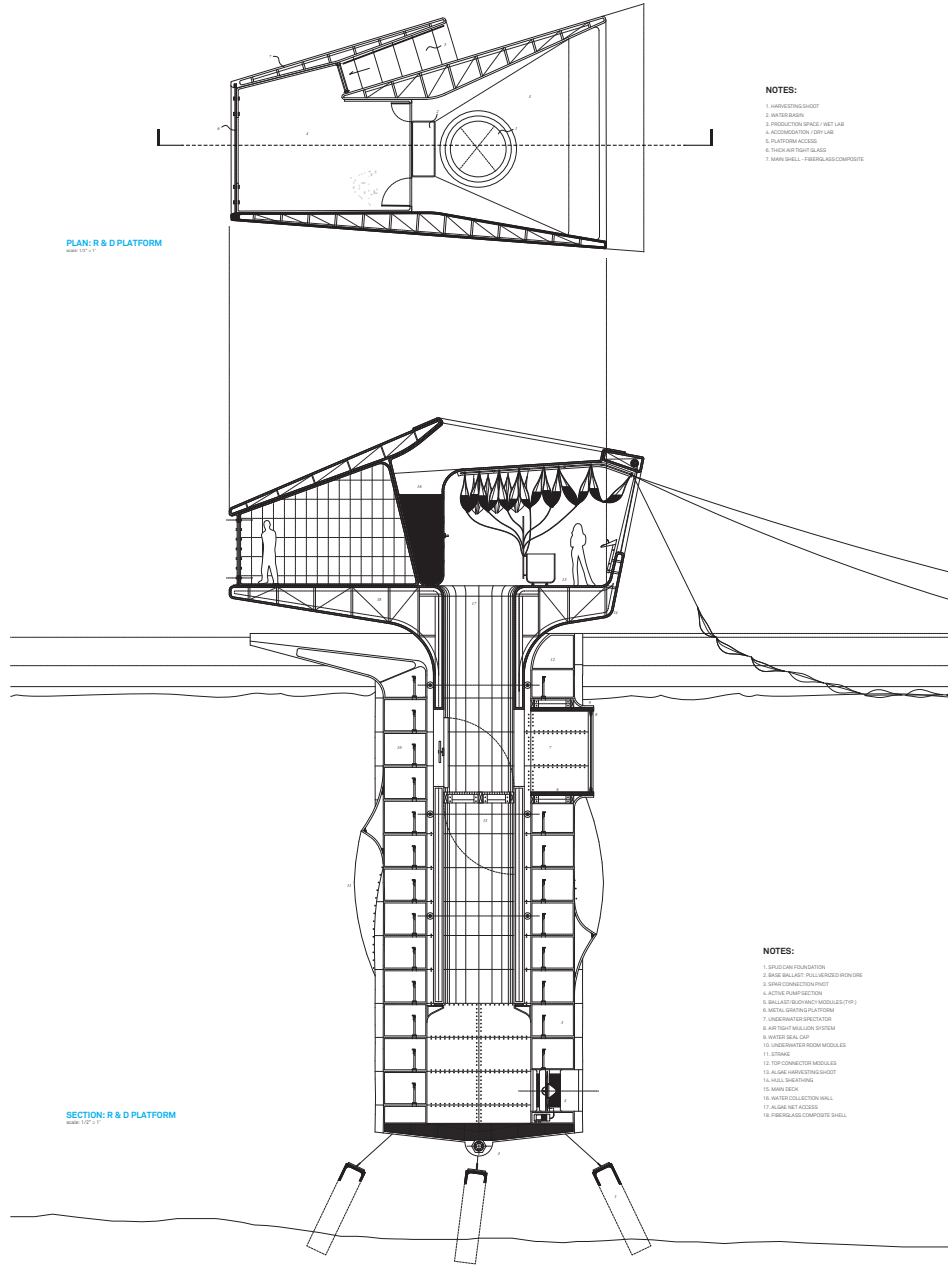

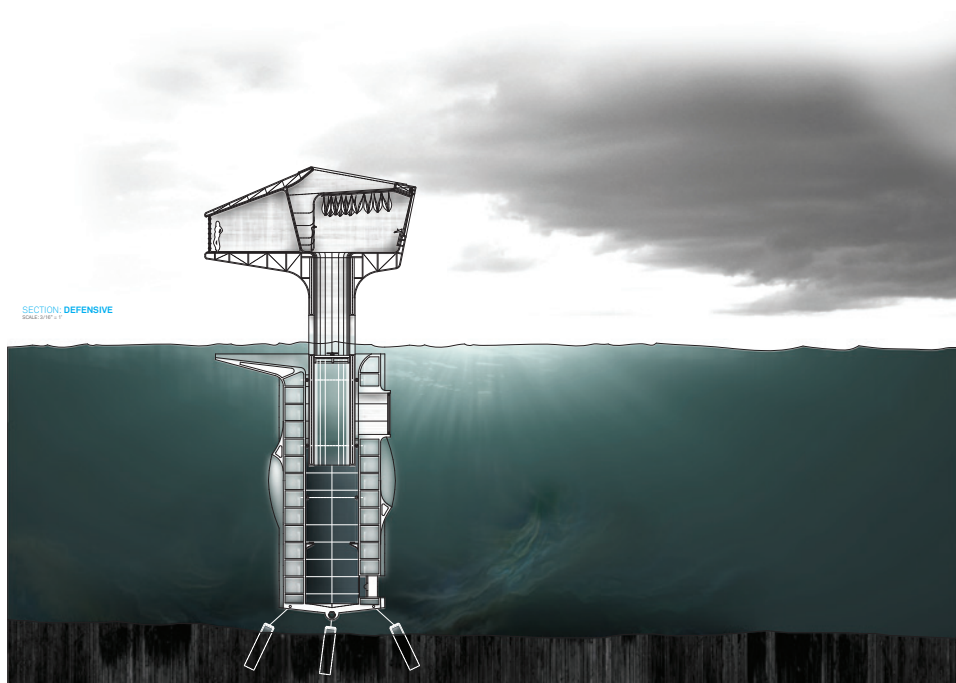
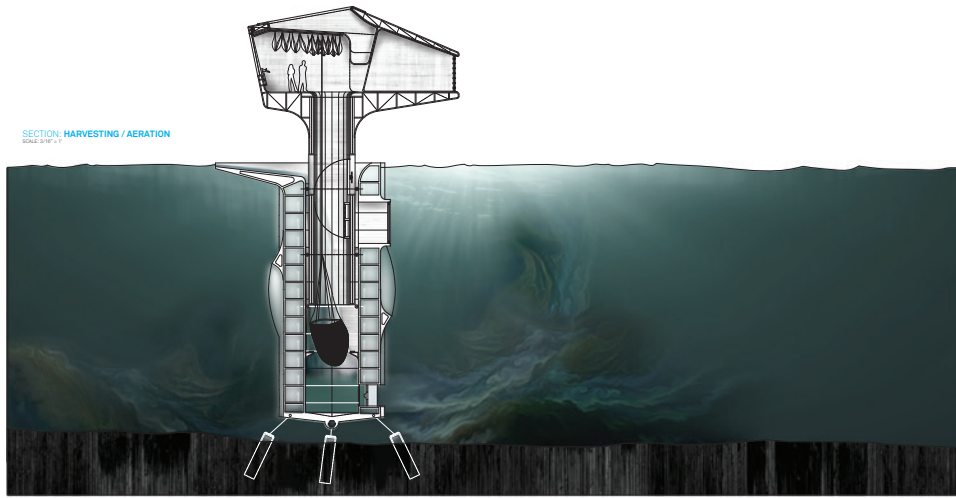
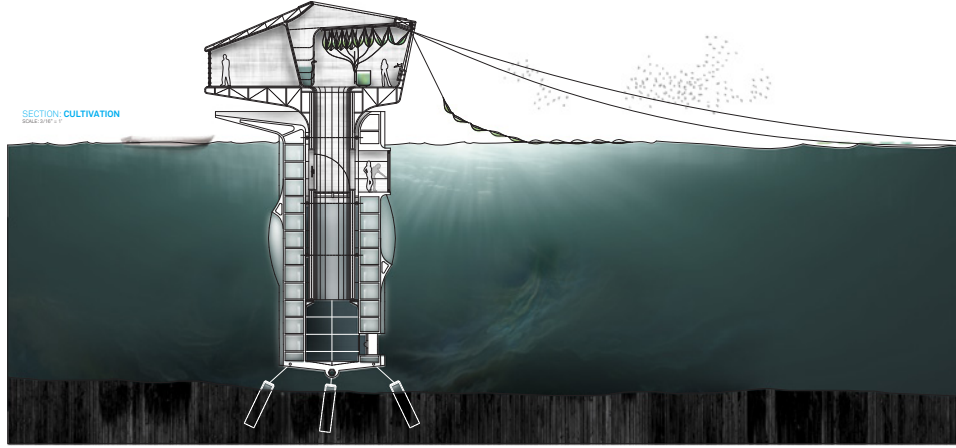

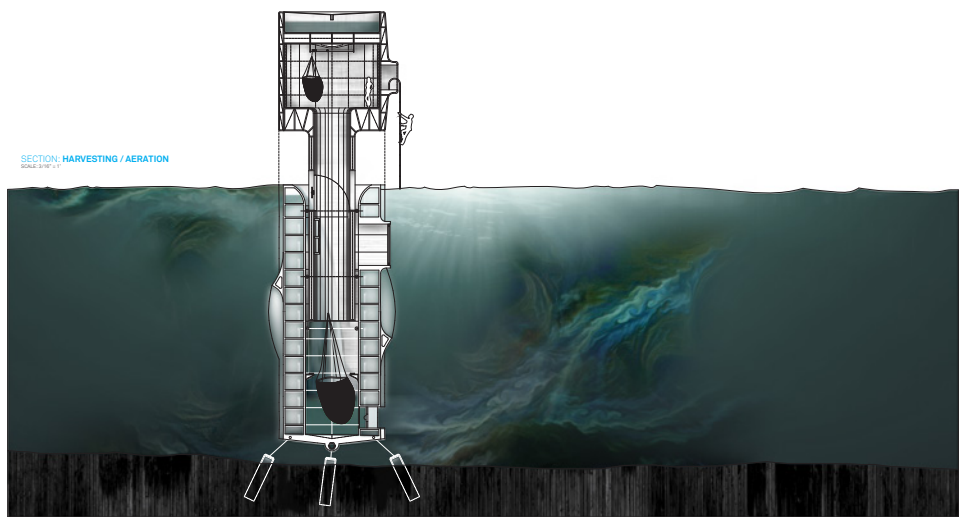
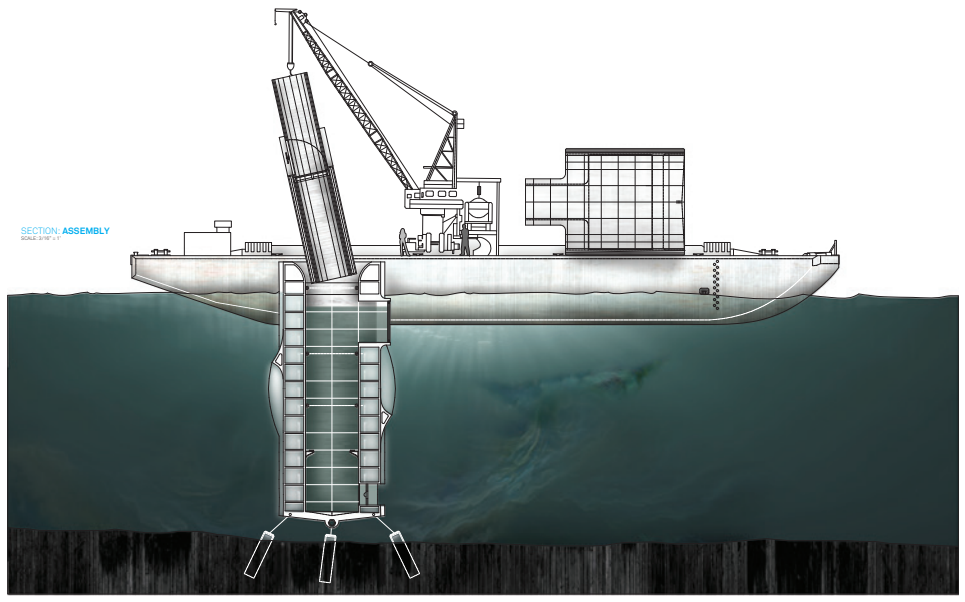
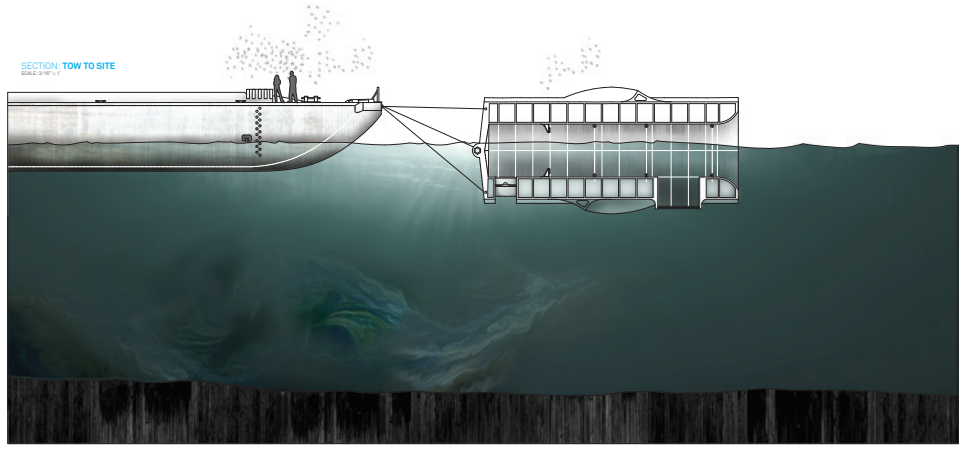



SECTION: BELOW SURFACE
HARVESTING
002.11.17

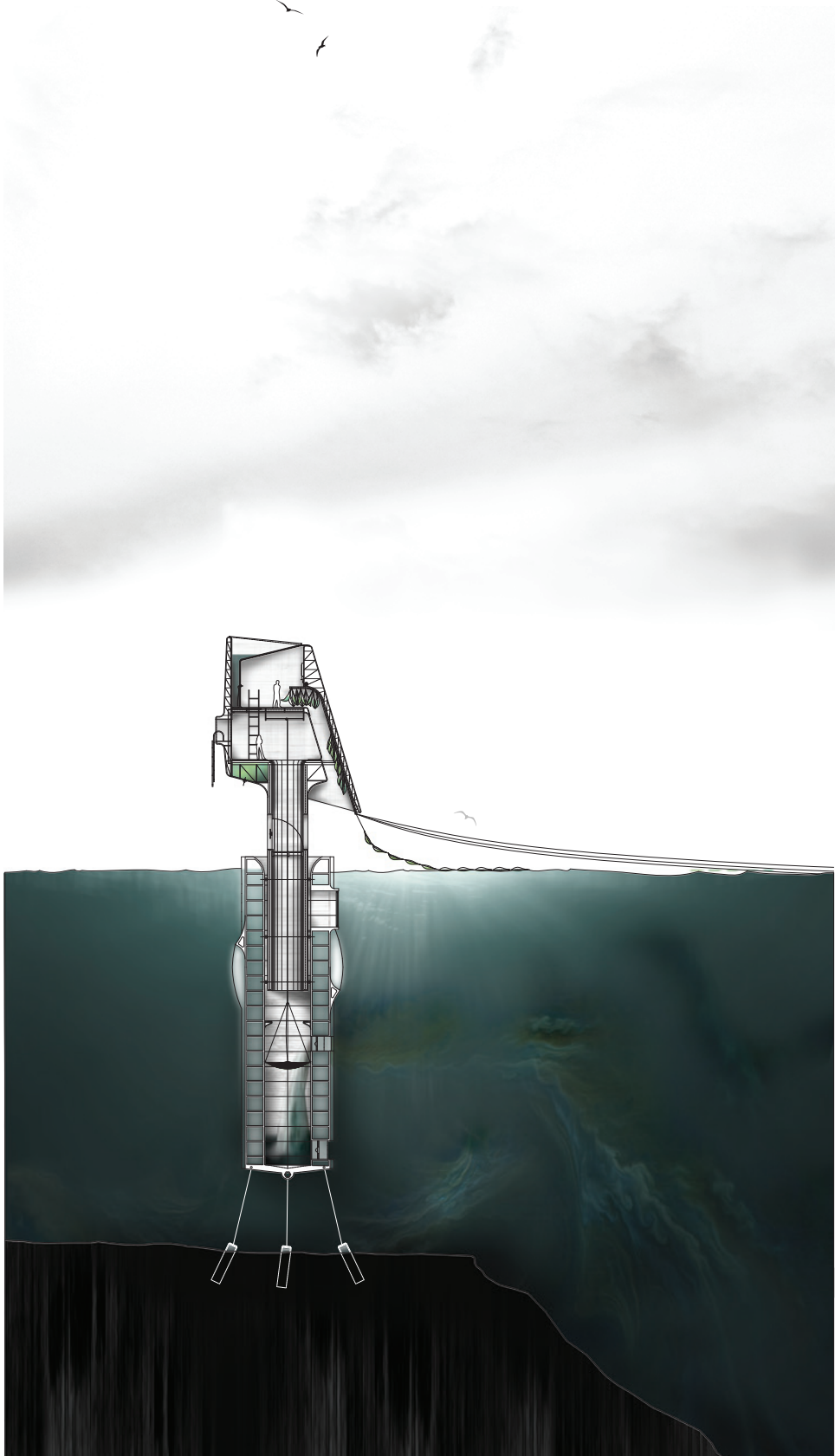

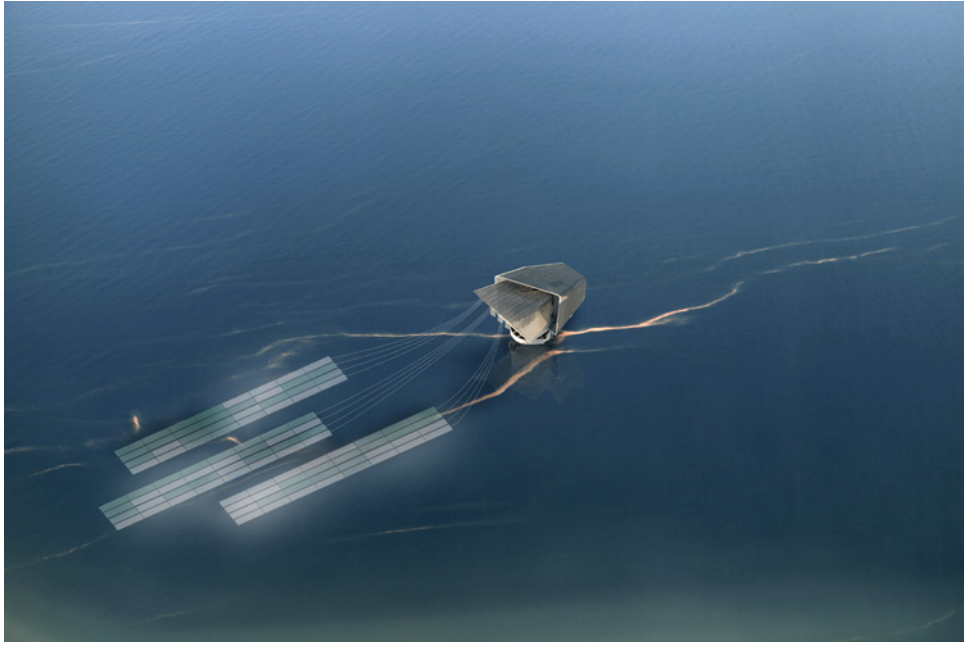

Deploying algae cultivation
(100-0000)



Underwater spectator
(100-0000000)

Harvesting algae blooms
(100-0000)



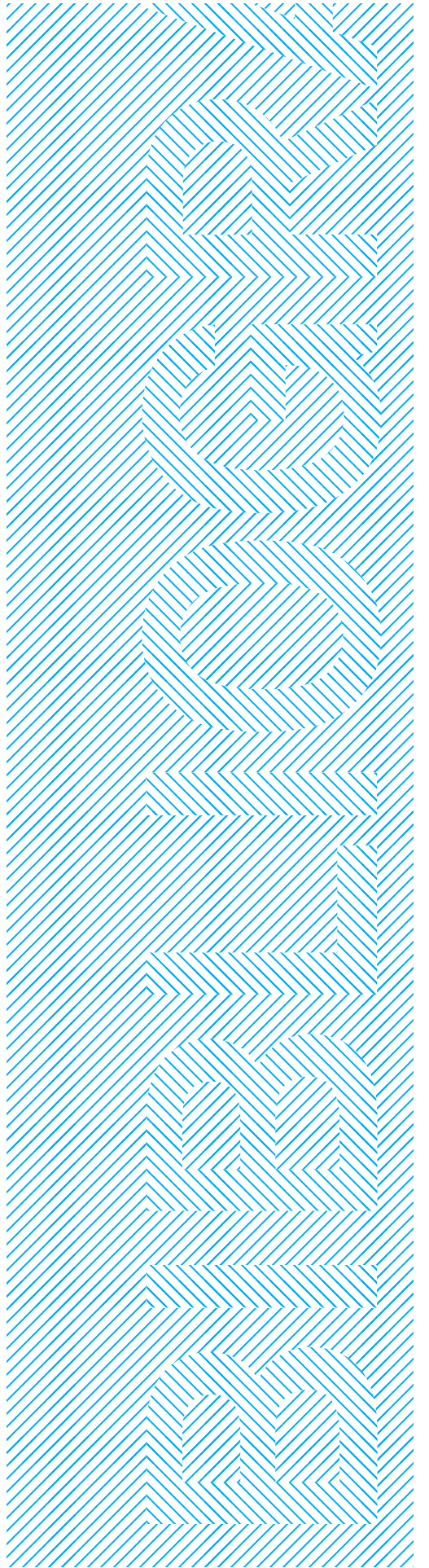

Bibliography

Maclachlan. *An Introduction to Marine Drilling*. Oilfield Publications Limited. Ledbury, England

Graham. *Offshore Engineering: Development of Small Oil Fields*. Goodfellow Associates Limited. 1986

Onshore Impacts of Offshore Oil

Offshore Oil and Gas (EEM)

Long-Term Environmental Effects of Offshore Oil

Brutton, Mark. *After the Oil Rush*. Avery Index of architectural periodicals. Pg. 46-49, July 1975

C. Homans. *After the Oil Rush in Alaska*. No. 3, Iss. 310, pg. 17-21. 2012

Guillot, Craig. *Oil Spill: Year One*. Vol. 77, Iss. 6, p. 12-17, 6p. July 2011

Mah, Alice. *Industrial Ruination, Community, and Place: Landscapes and Legacies of Urban Decline*. University of Toronto Press. 2012

Morris Architects. *Hotelier at Sea*. BLDG Blog. 17 Feb. 2009 <http://bldgblog.blogspot.com/2009/02/hotelier-of-sea.html>

Lovins, Amory B. *Winning the Oil Endgame: Innovation for Profits, Jobs, and Security*. Rocky Mountain Institute. 2005

Tainter, Joseph. *Drilling Down: The Gulf Oil Debacle and Our Energy Dilemma*. Springer. 2012

NOAA. *Dead Zone: Hypoxia in the Gulf of Mexico. 2009*. Retrieved June 23, 2012.

Tyedmers PH, Watson and R, Pauly D. 2005. *Fueling global fishing fleets*. *Ambio* 34(8):635-8.

Sylvan, J. B., Q. Dortch, D. M. Nelson, A. F. M. Brown, W. Morrison, and J. W. Ammerman. 2006. *Phosphorus limits phytoplankton growth on the louisiana shelf during the period of hypoxia formation*. *Environmental Science and Technology* 40(24): 7548-53.

The Economist. *Blooming horrible: Nutrient pollution is a growing problem all along the Mississippi*. Retrieved June 23, 2012.

David Perlman, Chronicle Science Editor (2008-08-15). *Scientists alarmed by ocean dead-zone growth*. Sfgate.com. Retrieved 2010-08-03.

Acknowledgments

Many thanks to my advisor in many aspects Andrew Scott, as well as the committee for the Dead Zone Gediminas Urbonas, and Anton Garcia Abril. I also want to thank Sheila Kennedy; Shun Kanda; Galo Canizares; Eric Randall Morris; Julian Ocampo; Alexis Sablone; and Dave Miranowski for making this thesis possible.

