

STORE HOUSE

Unpacking the American Dream

by Kyle Barker

Bachelors of Science in Interior Design
University of Cincinnati, 2008

Submitted to the Department of Architecture
in partial fulfillment of the requirements for the
degree of Masters of Architecture at
the Massachusetts Institute of Technology

February 2014

© 2014 Kyle Barker. All rights reserved.

The author hereby grants to MIT permission to reproduce and to
distribute publicly paper and electronic copies of this thesis document
in whole or in part in any medium now known or hereafter created.

Signature of Author _____

January 21, 2014

Certified by _____

Ana Miljački, MArch, PhD
Assistant Professor of Architecture
Thesis Supervisor

Accepted by _____

Takehiko Nagakura, MArch, PhD
Associate Professor of Design and Computation
Chair of the Department Committee on Graduate Students

Thesis Advisor

Ana Miljački, MArch, PhD

Assistant Professor of Architecture

Thesis Readers

Cristina Parreño Alonso, MArch

Lecturer in Architectural Design

Rafi Segal, PhD

Visiting Lecturer in Architectural Design

STORE HOUSE

Unpacking the American Dream

by Kyle Barker

Abstract

Since 1950 the average US home has grown from 1100 square feet to over 2600 square feet. During this same period the average family size shrunk by a person, meaning that per capita residential square footage has more than tripled in less than 60 years. What's more, if one looks at residential storage capacity as an indicator of consumption, its notable that the average citizen has 830% more storage space today than they did in the fifties.

Paradoxically, in the last decade other forms of ownership have lost favor. The appetite for conventional ownership has been, in part, supplanted by a disinterest in maintenance and responsibility. Subscription services have begun to replace the conventional retail transaction. At first people rented the intangible and ephemeral but in the last few years they have begun renting things that would have seemed technologically impossible, or at a minimum improbable, ten years ago. This new mode of collective ownership represents a societal shift that architecture is lagging behind.

This thesis aspires to use the spatial generosity of storage and the burgeoning sharing economy to re-imagine a suburb that promotes the sharing of rarely used objects & spaces amongst neighbors to foster community and reduce consumption.

Thesis Supervisor

Ana Miljački, MArch, PhD

Title

Assistant Professor of Architecture

Submitted to the Department of Architecture on January 21, 2014 in partial fulfillment of the requirements for the degree of Masters of Architecture.

To Ana

Thank you for your total commitment to this. Your dedication and intellect are truly unfathomable. It has made me incredibly happy to have had the chance to work with you over the past three and a half years. To the beginning of many future endeavors together!

To Cristina & Rafi

Thank you for poignant comments at just the right moments.

To Karina, John, Kyle, Toshi, Daniela & Kam

Thanks for making every day in studio feel like Christmas and for always joining me to go get a snack, even though its probably why we're all so poor now.

To Kyle, David & James

I literally couldn't have done it without you. I am so grateful to you for your generous gifts of time and talent at the end. Beyond the things you helped with, your attitudes & positivity helped me make that final push.

To Alexander, Ana, Anne, Ashley, Cristina, Joel, Meejin, Miho & Sheila

Your academic insights—both content and delivery—will be bouncing around in my head for a long, long time.

To the MIT Architecture Community

I've really loved getting to know you over the past three and a half years.

To the donors of and the selection committees for the Lois C. Rosenberg Travel Fellowship, the Rosemary D. Grimshaw Thesis Prep Award and the ZGF Architectural Scholarship Fund

Thank you for the scholarships that made (1) traveling to Europe to visit my favorite housing projects and (2) buying a new laptop possible.

To My Family

Thank you for your support & understanding throughout and for trekking from Ohio, Maine & Southern Massachusetts for the final review. It was great to have you there smiling in the audience. And thanks for holding your comments during the review ;).

To Susan, Ryan, Carla, Pam, Irina, Mariel, Michael, Tom & Kathleen

Thanks for taking the time off work to come and see the final presentation!

And lastly, to Rob

Thanks for always understanding why I couldn't have fun on weekends and for being the #1 member of my fan club. I love you so very much.

STORE HOUSE

Unpacking the American Dream

by Kyle Barker

- | | | | |
|----|---|-----|--|
| 06 | <u>The Introduction</u>
Culture of Consumption | 118 | <u>The Suburban Analysis</u>
Perfect Strangers |
| 18 | <u>The Argument</u>
A Storybook Beginning | 134 | <u>The Contextual Analysis</u>
Tomball, Texas |
| 38 | <u>The Typological Analysis</u>
Cataloging Desire | 144 | <u>The Urban Proposal</u>
Sharing Across Scales |
| 62 | <u>The Disciplinary Lineage</u>
A Spectrum of Collectivity | 154 | <u>The Appendix</u>
Experiments and Research |
| 78 | <u>The Design Methodology</u>
Dismantling the House | | |
| 92 | <u>The Architectural Proposal</u>
Store House | | |

CULTURE OF CONSUMPTION

The Introduction

06

On May 22, 2013 the American Psychiatric Association added "Hoarding Disorder" to the Fifth Edition of the *Diagnostic Statistical Manual* (DSM-V), the "Psychiatric Bible" used for diagnosing mental-disorders. Put simply, the resultant spatial clutter of owning too much is psychologically taxing. Studies have shown that most people use approximately a fifth of their possessions frequently. Within the remaining 80 percent, some possessions are used occasionally, some are relegated to the basement and forgotten about, and some are used so infrequently that they are sent to off site personal storage facilities. As we accumulate, we have a disaster-preparedness mindset of "what if?" but the "disasters" we prepare ourselves for are trivial: running out of wine glasses at a dinner party, not having the right shoes for a date, and on and on.

At the same time that popular culture is overwhelming us with stories of *Hoarders*, *Animal Hoarders* and *Storage Warriors*, we are being fed a host of narratives about smallness and austerity. Technology has gone from “mini” to “nano.” The news reports that people are migrating to urban cores and abandoning the spatial excesses of suburbia. But things aren’t getting smaller, at every turn every thing is getting bigger—much bigger. Houses are larger than ever (but family size *is* smaller). There is enough self-storage for every resident of the US to have seven and a half square feet to themselves. Televisions have gone from “big screen” to “cinema display.” Waistlines have gone from 34” to 38.” And the world’s population is projected to double by 2080. Even the few instances where things appear smaller is illusory. Take technology; while our hand-held devices have shrunk, their overall footprint has grown. Transactions that used to occur in the palm of our hand now occur thousands of miles away in mammoth, consolidated data centers. It’s a matter of where one draws the boundary, but there is no doubt that smallness is a fantasy.

Paradoxically, in the last decade certain forms of ownership have gone out of vogue. Clearly it’s not that people don’t want things anymore, but their appetite for conventional ownership has been overridden by their disinterest in maintenance and responsibility. Subscription services have largely replaced the conventional retail transaction. At first we rented the intangible and ephemeral—music, videos and television—but in the last few years we have begun renting things that would have seemed technologically impossible, or at a minimum improbable, 10 years ago: clothing, fash-

ion accessories, automobiles and even pets. This new model of collective ownership—different from its Soviet cousin—represents a societal shift that architecture is lagging behind. What if there was an architecture that could sponsor a sharing of rarely-used, but necessary, possessions? In a lean economy, economizing on the things we buy and sharing them makes financial sense.

The time line that follows this text illustrates these conflicting societal trends: the American need to consume, collect & display and its inverse, the societal shift from ownership-based to membership-based models of consuming. Rather than seeing this as a progression from the former to the latter, as many cultural critics do, I propose that these two currents will exist alongside one another indefinitely. They represent two distinct models of capital that each have a *raison d’être* in contemporary culture.

Organizational Origins

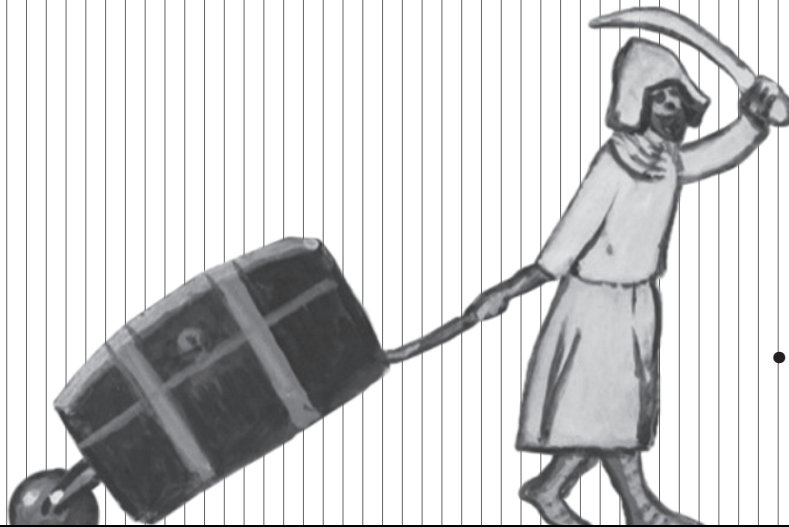

- Printing press created by Johannes Gutenberg

- First wheeled luggage appears in Palestine during the Crusades; used to transport weapon-mending equipment

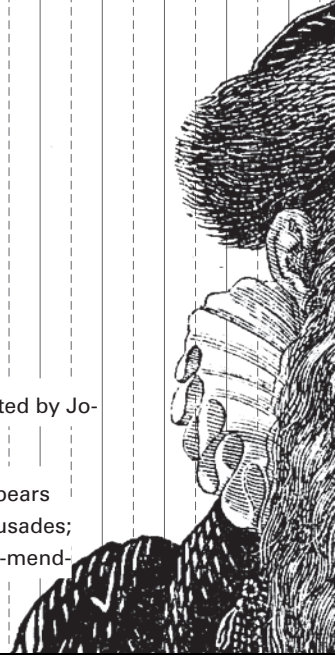

3000 BCE

1000 BCE

300

1450

1500

- Chinese use clay pots to store belongings in communal pits

- Library of Alexandria opens

This time line looks at consumption through the lenses of mobility (both personal and societal), seriality (mass production as well as financial instruments) and acquisition (collecting & storing across scales).





The earliest pictorial record of a natural history cabinet is the engraving in *Ferrante Imperato's Dell'Historia Naturale*

Store House



•••• American

1550

1600

1650

1700

1750

09

- Francis Trigg's Chained Library in Grantham, Lincolnshire becomes first public lending library

- First found mention of the Conestoga Wagon: a covered wagon capable of transporting 8 tons of cargo

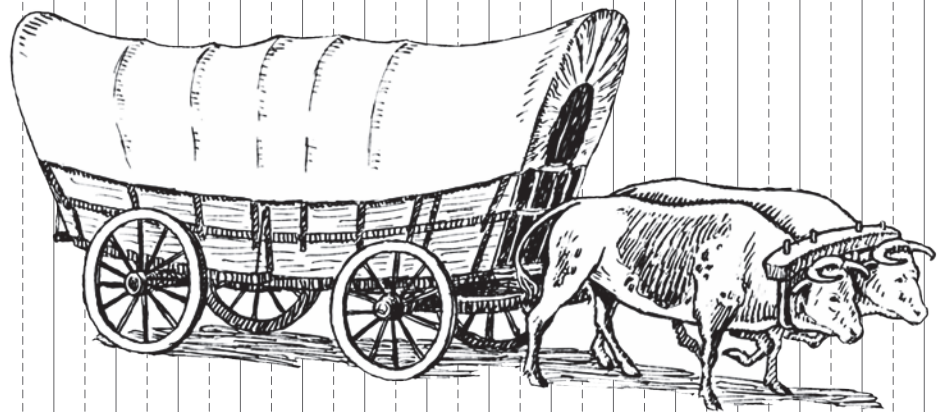

The Domestic Closet & the Modern Library



Library of Congress founded in Washington DC
American Revolutionary War

- Andrew Jackson Downing in *Cottage Residences*: "The universally acknowledged utility of closets makes it unnecessary to say anything to direct attention to them"

1800

1810

1820

1830

1840

1850

1860



- Americans use the covered wagon to head west
 - Sir John Soane establishes his museum via a Private Act of Parliament
 - First tax-supported public library in US founded in Peterborough, New Hampshire

- UK Parliament passes *Public Library Act*, allowing cities with populations over 10,000 to levy taxes for the support of public libraries
- *American Express* formed: specializes in deliveries
 - *Louis Vuitton* begins as a maker of fine luggage



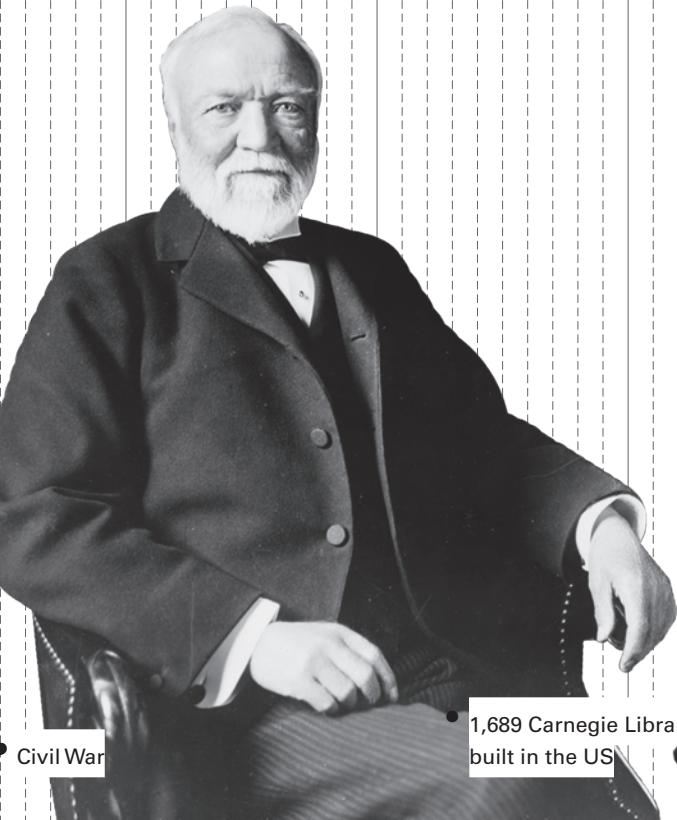

Store House



Civil War

1,689 Carnegie Libraries built in the US

Opening of the Isabella Stewart Gardner Museum

1870

1880

1890

1900

1910

1920

Surveyor

- Melvil Dewey creates Dewey Decimal system
- American Library Association formed

- American Express invents traveler's checks

World War I

- Automob...
- or 'Traile...
- duced fo...

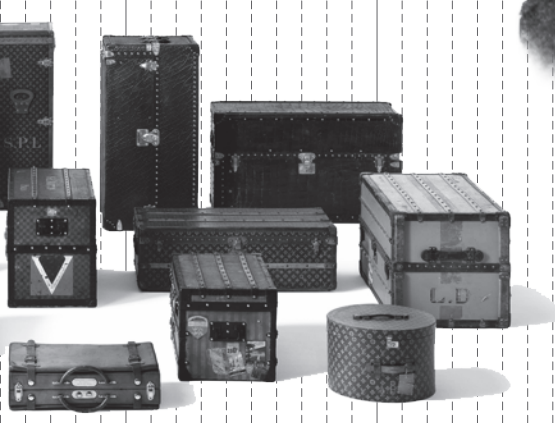

Credit Cards & Big Boxes

- Magnetic Drum introduced

Black Tuesday" Stock Market Crash in US

Magnetic Tape introduced

Hur Trachte builds interconnected metal garages for "cars about homes"

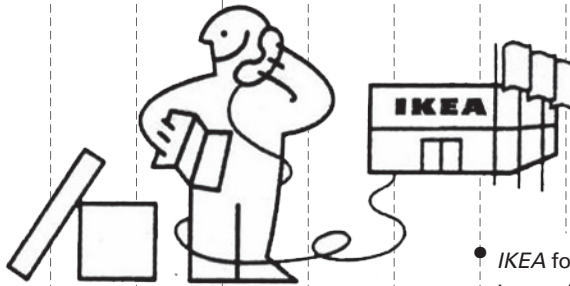

- IKEA founded in Sweden by Ingvar Kamprad



1930

1935

1940

1945

Mobile-pulled trailers
for Coaches' intro-
for camping

In *The Personality of a House*, Emily Post suggests 20" (for women) or 24" (for men) as the ideal closet depth

Le Corbusier: "What [modern man] wants is a monk's cell, well lit and heated, with a corner from which he can look at the stars."



- World War II
- U-Haul founded
- LIFE commissions George Nelson to design a wall storage system for Herman Miller
- Microfilm introduced

Langley Collyer
130 tons of his
elaborate boob





U-Haul begins renting one-way trailers



Store House

- U-Haul fleet grows to 42,600 trailers
- American Express issues first plastic credit card
- First self-storage facility in the US opened by the Collum family under the name *Lauderdale Storage*
- First *IKEA* store opened in Almhult, Smaland
- American Express creates its first credit card: a purple card for travel and entertainment expenses



1950

1955

1960

1965

- First Credit Card created: *Diners' Club Card* made of cardboard
- 20,000 *Diners' Club* Cardholders reported

found dead beneath possessions, set as traps for burglars

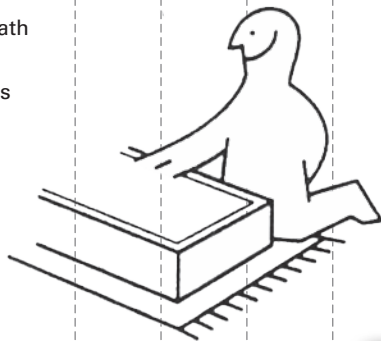

- Term "Mobile Home" introduced along with 10-foot width standard
- American trucker Malcolm McLean invents & patents the shipping container
- *IKEA* develops "flat pack" furniture to increase shipping efficiency
- Cassette Tape introduced
- Hard Disk introduced



- Founding of *Walmart*

- Russ Williams & Bob Mu... their first self-storage fa... Odessa, Texas called A-1... U-Lock-It U-Carry the Ke...

WAL★MART



The Cult of Organization



Compact Disk introduced

- Invention of the barcode: a 10-pack of Wrigley's Juicy Fruit gum becomes the first 'scanned' item

- *The Container Store* opens its first store
- *California Closets* is founded

1970

1975

1980

- May 1968 Protests

unn build
cility in
U-Store-It
ey

- 8" Floppy Disk introduced
- Bernard Sadow receives US patent 3,653,474 for 'Rolling Luggage'

- *Self Storage Association (SSA)* formed

- 5.25" Floppy Disk introduced

- US Congress of term fro
"Manufact

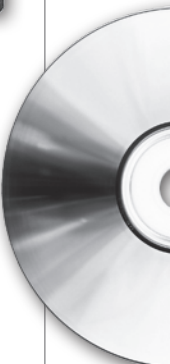
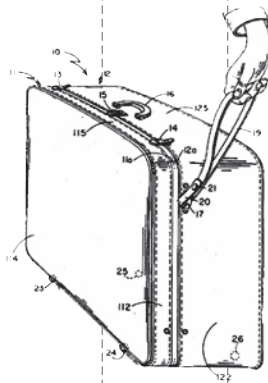
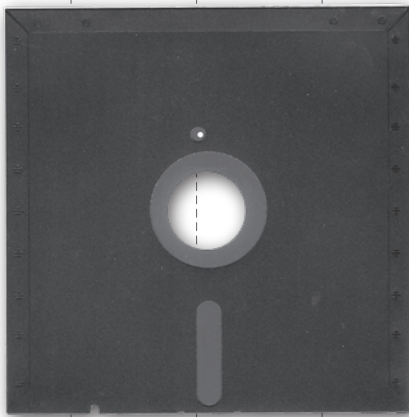



Store House

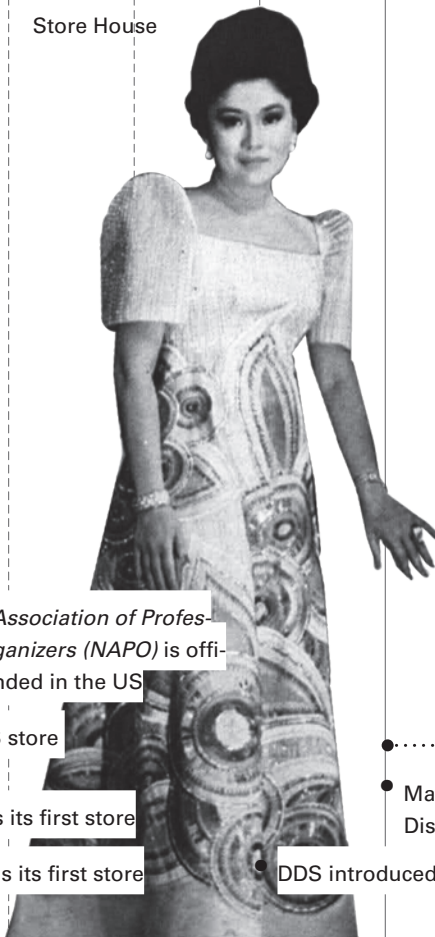

3.5" Floppy Disk introduced



National Association of Professional Organizers (NAPO) is officially founded in the US

- IKEA opens its first US store in Philadelphia
- Hold Everything opens its first store
- Organized Living opens its first store

- Gulf War
- Magneto Optical Disk introduced



Mini Disk introduced

DDS introduced

1985

1990

Congress approves change from "Mobile Home" to "Manufactured Home"

- Sam's Club opens its first store in Midwest City, OK
- Costco opens its first store in Seattle, Washington

CD-ROM introduced

- Imelda Marcos flees Malacañan Palace, leaving behind 15 mink coats, 508 gowns, 1000 handbags and 1060 pairs of shoes
- US pilot Robert Plath invents "Rollaboards": upright suitcases on two wheels pulled by a handle



The Age of Hoarding



- DVD introduced
- Memory Stick introduced
- Amazon sells first book

• Zipcar Founded

• Napster created by Shawn & John Fanning & Sean Parker

- Mission: Organization premieres on HGTV
- Clean Sweep premieres on

fac

1995

2000

- Amazon founded by Jeff Bezos under the name "Cadabra"
- Compact Flash introduced
- Zip Disk introduced



- Wikipedia launched by Jimmy Wales & Larry Sanger
- September 11th Attacks
- War in Afghanistan
- SD Card introduced
- USB Key introduced
- Network Server introduced
- iTunes launches

• Facebook la



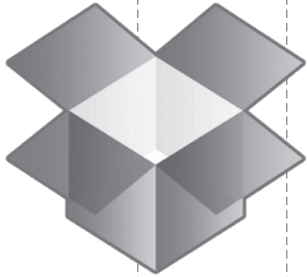

TLC



• Spotify launches

• Dropbox founded by MIT students, Drew Houston & Arash Ferdowsi

Store House

• *Confessions: Animal Hoarding* debuts on *Animal Planet*

• *Hoarding: Buried Alive* premieres on TLC

• First episode of *Auction Hunters* airs

• First episode of *Storage Wars* airs

• "Hoarding" or "Pathological Collecting" considered for inclusion in the *DSM-V* as a psychiatric disorder provisionally named, "Hoarding Disorder"

• Pinterest launches in closed-beta testing mode

• Iraq War



• Zipcar at 770,000 users

• Facebook reports 1.06 billion active monthly users

2005

2010

launches

• *California Closets* reports an annual revenue of \$241 million

• *Hold Everything* goes out of business

• *Clean Sweep* is cancelled

• *Organized Living* declares bankruptcy, closes brick & mortar stores but maintains *OrganizedLiving.com*

• *Hoarders* premieres on A&E



• *LifeEdited* Apartment built

• Pinterest hits 11.7 million unique users: fastest site in history to break 10 million unique user mark

• "Hashtag" chosen as the "Word of the Year" by the *American vDialect Society*

• New wing of the *Isabella Stewart Gardner Museum*, designed by Renzo Piano, opens

• Spotify reaches 20 million users

• Sylvia Lavin writes 'Exposing Excess' regarding the architectural potential of hoarding in *Log 22*

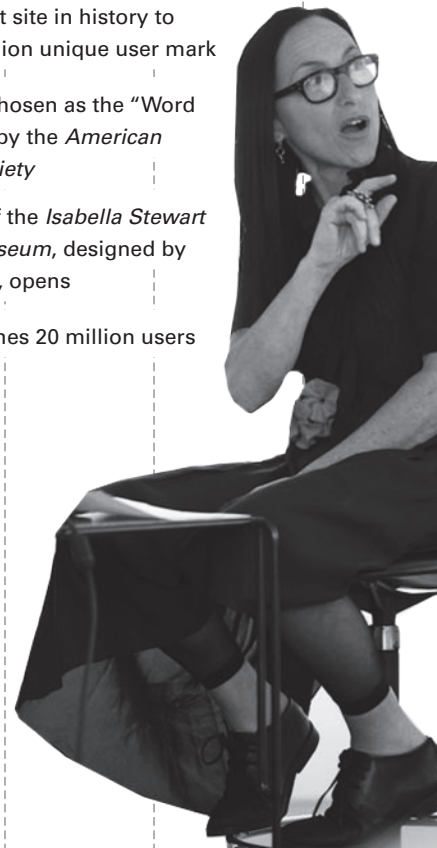

A STORYBOOK BEGINNING

The Argument

The sub-prime mortgage crisis has, rightfully, been pinned on irresponsible financial institutions. While there is no doubt that predatory lending and convoluted financial instruments played a decisive role in bringing the global economy to its knees, their greed was enabled by the rampant consumptive practices of Americans. As we've known for quite some time, our consumerism is extreme within the global context, but even if we limit the scope of our inquiry within national borders, the story it tells is shocking.

Because the American economy revolves around the single-family home—after all the health of the economy is measured in “housing starts”—its evolution can serve as an effective barometer of American consumption over time. Since 1950 the average US home has grown from 1100 square feet to—at the time of the collapse—over 2600 square feet. During this same period the average family size shrunk by a person: meaning that our per capita residential square footage has more than tripled in less than 60 years. What's more, if we look at residential storage capacity as an indicator of consumption over the same time period, its notable that the average citizen has 830% more storage space today. This is 133 square feet for every person, a number that doesn't even include the seven square feet of self-storage that each person could have (or their garages or basements or digital footprints, etc).

Obviously this sort of exponential growth is unsustainable in both senses of the word. On September 18, 2008 Fed Chairman Ben Bernanke told a group of key legislators, including Treasury Secretary Henry Paulson, “If we don't do this, we may not have an economy of Monday.” He was referring to a proposal for a \$700 billion emergency bailout via the purchase of toxic assets. During the previous two weeks the US Government had taken over Fannie Mae and Freddie Mac, the Federal Reserve had lent \$85 billion to *American International Group* (AIG) to save them from bankruptcy and *Lehman Brothers* had filed for bankruptcy protection. This string of events heralded the pop of a housing bubble that had been growing exponentially since the end of the Great Depression. Two weeks later the stock market would hit a 75-year low—after hitting record highs the previous October—and the Fed would approve an additional \$900 billion in short-term cash loans to banks. The same week Europe's financial markets began to tank. The global financial crisis had begun and it all started with a house, an American house.

Therefore, this thesis proposes that...

**Bad design is
responsible
for the financial
collapse.**



We have bought in to a dream that "Bigger is Better."

22

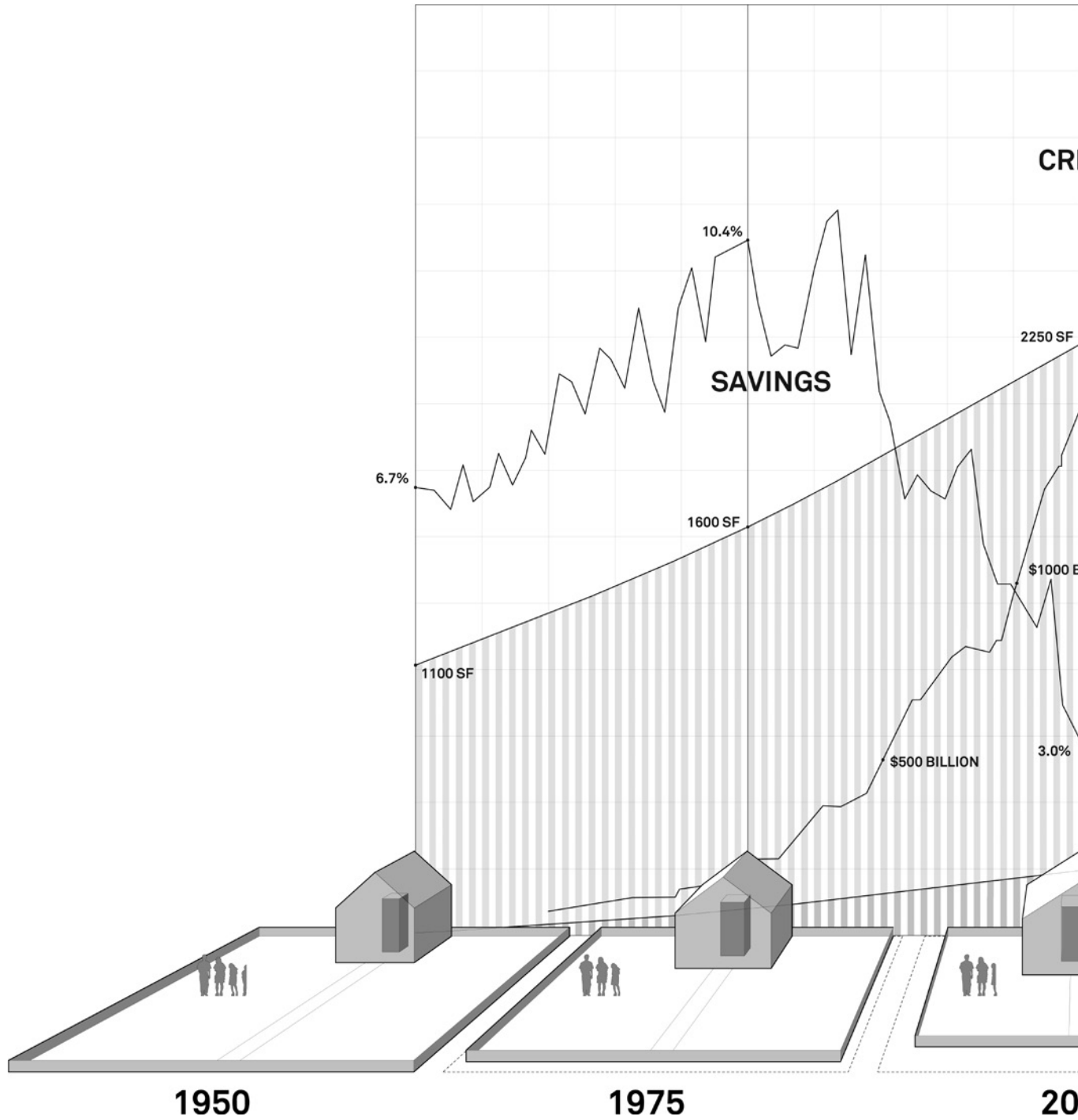

This dream has lead to larger homes...

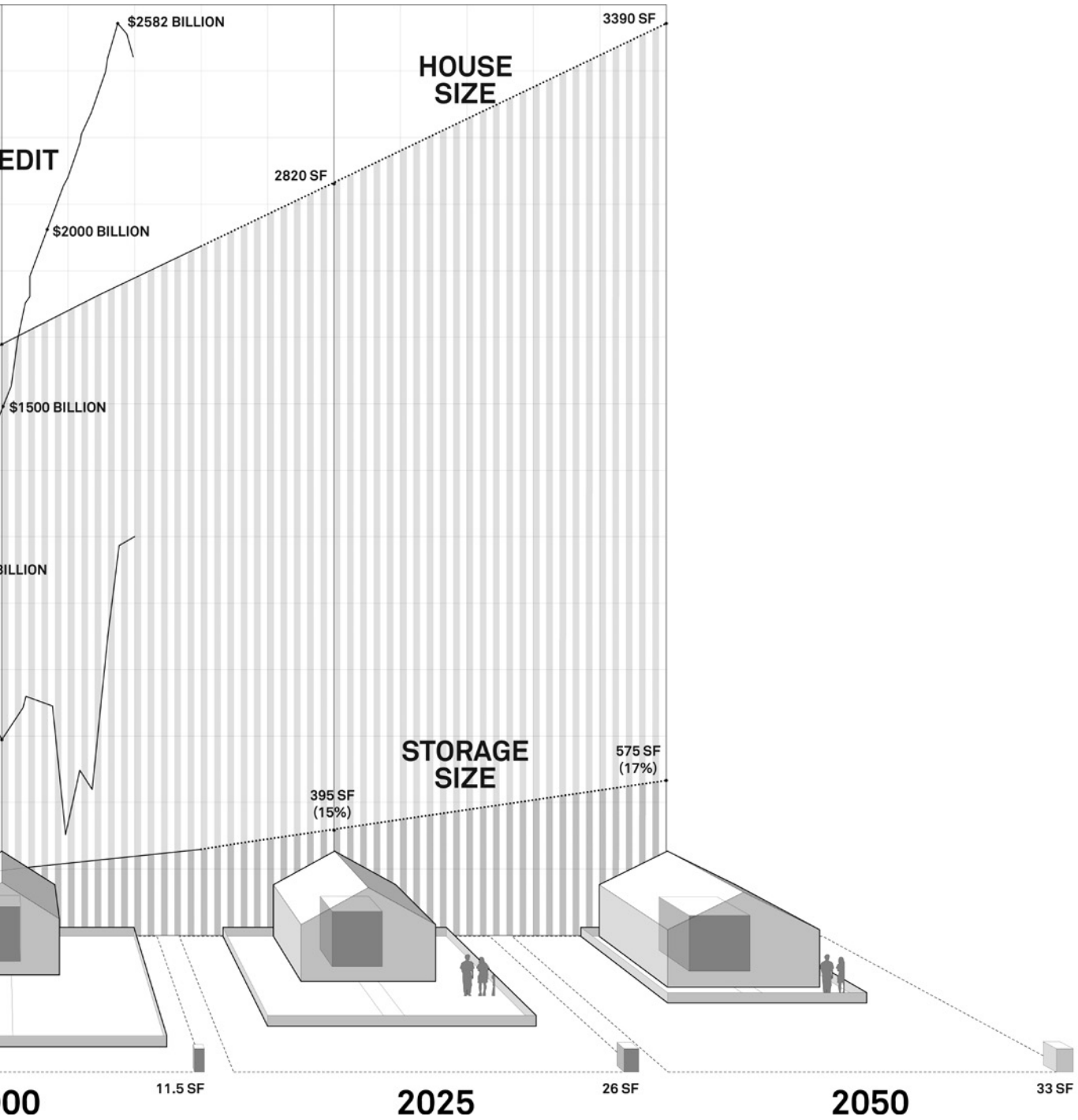

Storage accounts for 12% of the total space in new homes.

US per capita Storage Space: 140 sf
Hong Kong per capita Living Space: 154 sf

Sources: *Toll Brothers*, the World Bank



...with more storage...



...that holds more things...



In 2006, Americans spent over
\$7 Billion on organizational products.

The GDP of Haiti is \$7.84 Billion.

Sources: *Mother Jones*, the World Bank



...sponsors new disorders...

—
Scientific American estimates that
between five and fourteen million Americans
are Compulsive Hoarders.

Conservatively, this gives a ratio of
well over one hoarder per one-hundred people.



...and is environmentally and financially unsustainable.

Two acres of prime farmland are developed into suburbs each minute. Yearly, this is equivalent to an area twice the size of Manhattan (1,650 sq mi).

As of July 2013, there were 4.4 million completed foreclosures in the United States since the start of the financial crisis in 2008.

Sources: American Farmland Trust, *Business Insider*



**That said, one can spot
the emergence of a new model
based in sharing.**

**Not a nostalgic hippie or socialist
version, but rather...**

30



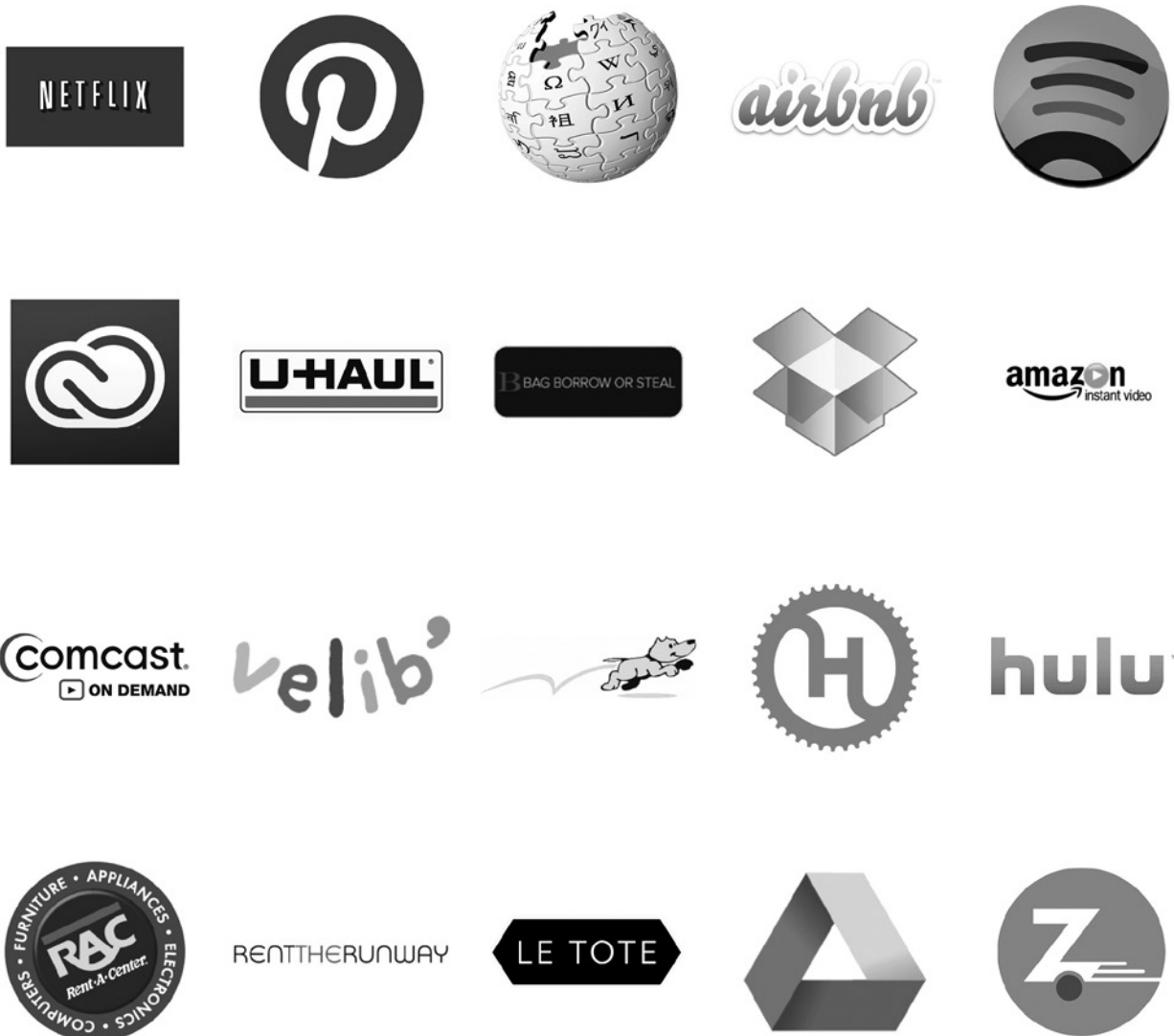

...one that operates through rental models. In the past fifteen years we've gone from renting the ephemeral—music, television and videos—to renting staples—cars, bikes and now clothing.



32

**If the average person uses
20% of their possessions
80% of the time one can imagine
an architecture that sponsors a
sharing of the rarely used.**





33



If the dream of the huge detached single-family home has resulted in sprawl and financial collapse...

What reality might a different dream create?

34



The Buell Center at Columbia University posed this question in the publication that spawned the 2012 MoMA show, “Foreclosed: Rehousing the American Dream.”



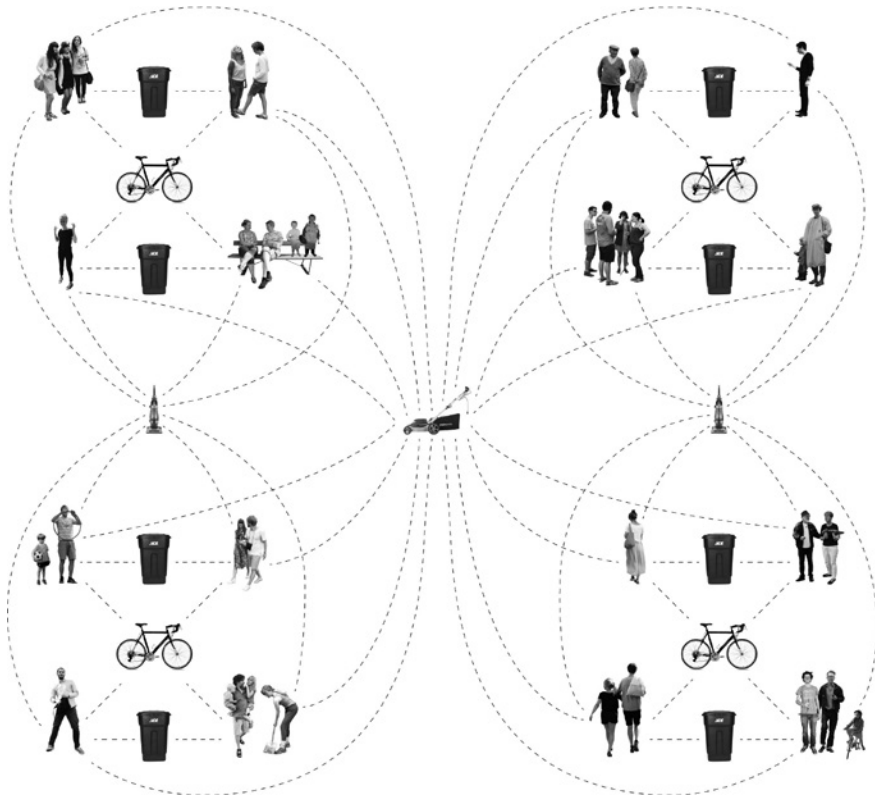

**This project picks up where
“Foreclosed” left off, seeking to shift
the dream through architecture.**



Borrow more than a cup of sugar.

Store House proposes a re-imagined suburb that promotes the sharing of rarely used objects & spaces amongst neighbors to foster community and reduce consumption.

CATALOGING DESIRE

The Typological Analysis

By now, the rhetoric that 70% of the world's population will live in cities by 2050 is firmly implanted in our collective consciousness. However, the definition of what constitutes a city remains unclear. Likely this statistic conjures a FARMAX-ian future of an even denser New York or a vertical Los Angeles, but based on current growth trajectories this is unlikely, at least in the American context. What is likely, is that the much denigrated "middle ring suburbs" will densify. We've been on the lookout for a denser Manhattan when we should have been imagining a denser Malden.

Between 1970 and 2000, the percentage of the total population living in suburbs grew from 38% to 50%. With 82% of adult millennials saying that owning their own home is "important" and another 43% calling the suburbs their "ideal place to live," it seems plausible that this trend will only intensify. These statistics suggest that it is time for architects to shift focus. For too long we have been fixated on the city to the detriment of the suburb. In our absence, developers have been all too happy to create and market their version of the dream which has yielded larger homes, record profits and a cataclysmic financial collapse. With developers leading the charge, the contemporary suburb has been shaped by the profit motive which has yielded a homogeneous product that is ill-suited to the diverse needs of communities.

To better understand an emerging subject that aspires to live in the suburbs but fears an increase in responsibility and a loss of community, the ten best-selling floor plans in the US were analyzed as a way of cataloging desire. Through a mapping exercise the homes were abstracted to draw out key organizational principles and programmatic ratios.

Interestingly, although all of the houses are designed by American firms, seven of the top ten homes have either French, Spanish or Italian names. The most popular terms to describe the home's exterior are "Cottage" and "Craftsmen" (beating out "Pet Lovers" 3:1. Yes, "Pet Lovers" is used to describe the *exterior* of certain homes). The average home size is 2085 square feet with three bedrooms and three bathrooms. All homes are single-story, although nearly all include the possibility for the addition of a Bonus Room: "free space" built within the cavity above the garage and typically used as either storage or a children's play area. Breakfast nooks and fireplaces are the most popular features (included in every plan here). And the average price for the PDF plans of is \$1,245.

Sturbridge II-C

#10 Best-Seller



40

<u>Identification</u>	<u>Sq Ft</u>	<u>Beds</u>	<u>Exterior Style</u>	<u>Features</u>	<u>Plan Pricing</u>
THD-JAA-4422	2233	4	Ranch	2-Car Garage	\$1055.00 (PDF)
	<u>Stories</u>	<u>Bath</u>	Country	Bonus Room	
	1.25	2.5	Craftsman	Breakfast Nook	
			Mountain	Fireplace	
			Pet Lovers	Home Center	
				Study	

Store House



Storage, First Floor
287 sf / 13%



Storage, Second Floor



Master vs Bedrooms
51'-2" between wings

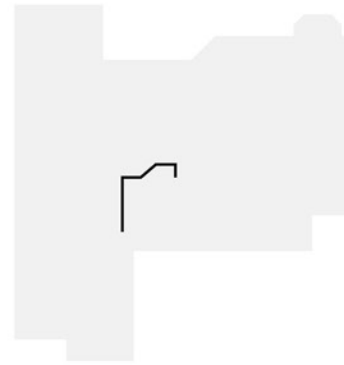

From Car to Fridge
37'-0" (8.2 secs)



Covered Outdoor Spaces
555 sf / 25%



Nature

Vida de la Confianza

#9 Best-Seller



42

<u>Identification</u>	<u>Sq Ft</u>	<u>Beds</u>	<u>Exterior Style</u>	<u>Features</u>	<u>Plan Pricing</u>
THD-EXB-2138	1698	3	Cottage Craftsman Farm House French Country Mountain Vacation Bungalow	2-Car Garage BBQ Porch Bonus Room Breakfast Nook Fireplace Screened Porch	\$1245.00 (PDF)
	<u>Stories</u>	<u>Bath</u>			
	1.5	2.5			

Store House



Storage, First Floor
158 sf / 9%

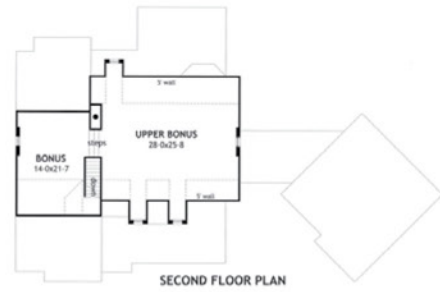

Storage, Second Floor



Master vs Bedrooms
24'-0" between wings

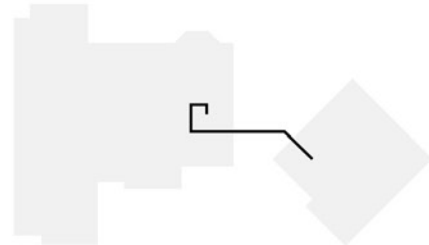

From Car to Fridge
49'-0" (10.9 secs)



Covered Outdoor Spaces
1018 sf / 60%



Nature

Montagna di Grazioso

#8 Best-Seller



44

<u>Identification</u>	<u>Sq Ft</u>	<u>Beds</u>	<u>Exterior Style</u>	<u>Features</u>	<u>Plan Pricing</u>
THD-EXB-3057	2106	3	Ranch Cottage European Mountain Vacation	2-Car Garage BBQ Porch Bonus Room Breakfast Nook Fireplace Study	\$1245.00 (PDF)
	<u>Stories</u>	<u>Bath</u>			
	1.5	2.5			

Store House



Storage, First Floor
233 sf / 11%



Storage, Second Floor



Master vs Bedrooms
44'-9" between wings

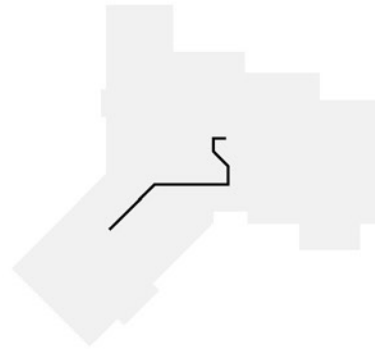

From Car to Fridge
53'-0" (11.8 secs)



Covered Outdoor Spaces
660 sf / 31%

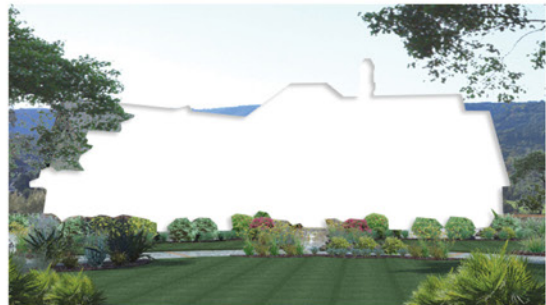

Nature

Merveille Vivante Small

—
#7 Best-Seller



46

<u>Identification</u> THD-EXB-2259	<u>Sq Ft</u> 1421	<u>Beds</u> 3	<u>Exterior Style</u> Bungalow Ranch Cottage Craftsman Farm House Vacation	<u>Features</u> BBQ Porch Bonus Room Breakfast Nook Fireplace	<u>Plan Pricing</u> \$1245.00 (PDF)
	<u>Stories</u> 1.5	<u>Bath</u> 2			

Store House



Storage, First Floor
157 sf / 11%



Storage, Second Floor



Master vs Bedrooms
36'-9" between wings



From Car to Fridge
No Garage



Covered Outdoor Spaces
602 sf / 42%



Nature

Ledoux

—
#6 Best-Seller



48

<u>Identification</u> THD-LCD-5483	<u>Sq Ft</u> 4731	<u>Beds</u> 4	<u>Exterior Style</u> Traditional European French Country	<u>Features</u> 3-Car Garage Bonus Room Breakfast Nook Fireplace Screened Porch Study	<u>Plan Pricing</u> \$1825.00 (PDF)
	<u>Stories</u> 1.5	<u>Bath</u> 4.5			

Store House

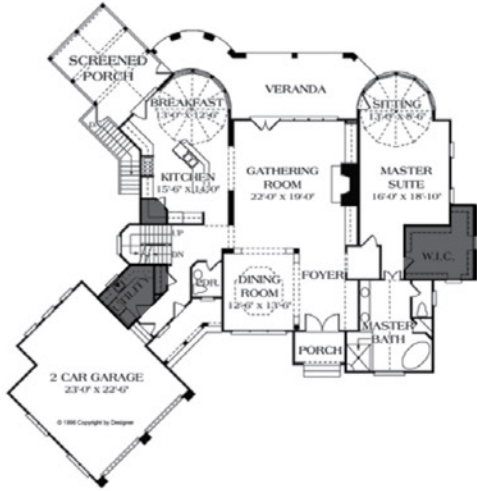

Storage, First Floor
607 sf / 7%

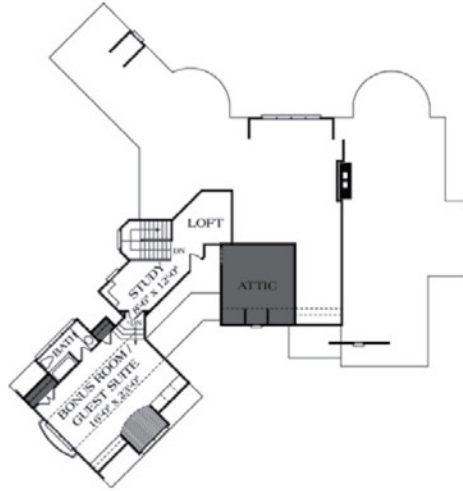

Storage, Second Floor
290 sf / 6%



Master vs Bedrooms
Only Master

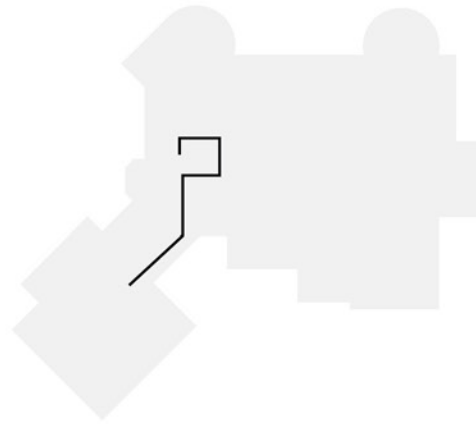

From Car to Fridge
66'-0" (14.7 secs)



Covered Outdoor Spaces
865 sf / 18%



Nature

La Meilleure Vie

#5 Best-Seller



50

<u>Identification</u>	<u>Sq Ft</u>	<u>Beds</u>	<u>Exterior Style</u>	<u>Features</u>	<u>Plan Pricing</u>
THD-EXB-2297	2847	3	Ranch Cottage Craftsman European Florida Mountain	3-Car Garage BBQ Porch Bonus Room Breakfast Nook Exercise Room Fireplace Study	\$1845.00 (PDF)
	<u>Stories</u>	<u>Bath</u>			
	1.5	3			

Store House



Storage, First Floor
269 sf / 10%



Storage, Second Floor
30 sf / 1%



Master vs Bedrooms
52'-4" between wings

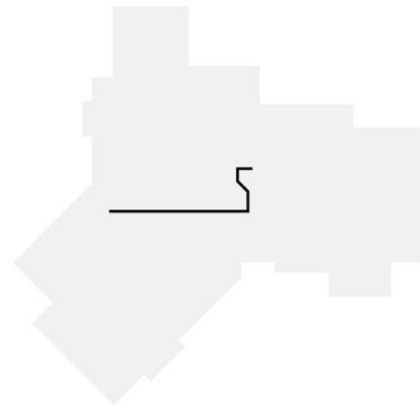

From Car to Fridge
52'-0" (11.6 secs)



Covered Outdoor Spaces
904 sf / 32%



Nature

Verona

—
#4 Best-Seller



52

<u>Identification</u>	<u>Sq Ft</u>	<u>Beds</u>	<u>Exterior Style</u>	<u>Features</u>	<u>Plan Pricing</u>
THD-LCD-4741	2074	3	Cottage Country Craftsman	2-Car Garage Bonus Room Breakfast Nook Fireplace Workshop	\$1200.00 (PDF)
	<u>Stories</u> 1.5	<u>Bath</u> 3.5			

Store House



Storage, First Floor
308 sf / 15%



Storage, Second Floor



Master vs Bedrooms
44'-0" between wings

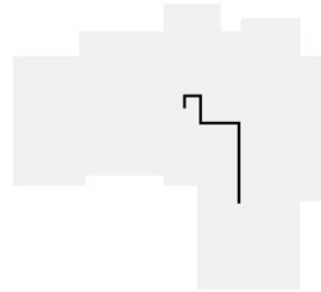

From Car to Fridge
47'-0" (10.4 secs)



Covered Outdoor Spaces
314 sf / 15%

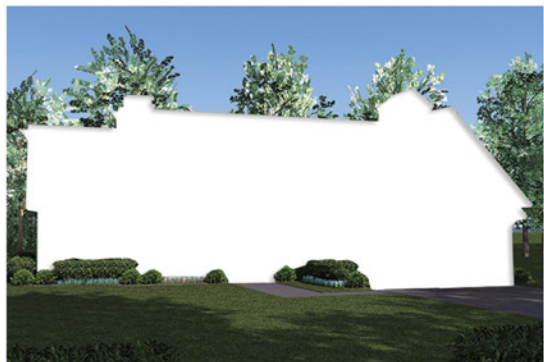

Nature

The Lexington Ridge

#3 Best-Seller



54

<u>Identification</u>	<u>Sq Ft</u>	<u>Beds</u>	<u>Exterior Style</u>	<u>Features</u>	<u>Plan Pricing</u>
THD-IQH-7139	1800	3	Country Craftsman Cottage Pet Lovers	2-Car Garage Bonus Room Breakfast Nook Flex Space Fireplace Workshop	\$885.00 (PDF)
	<u>Stories</u>	<u>Bath</u>			
	1.5	2			

Store House

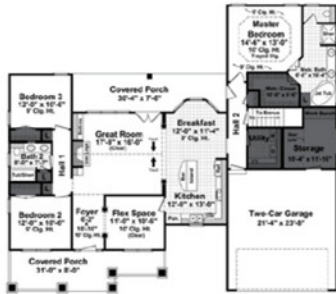

Storage, First Floor
318 sf / 18%



Storage, Second Floor



Master vs Bedrooms
54'-3" between wings

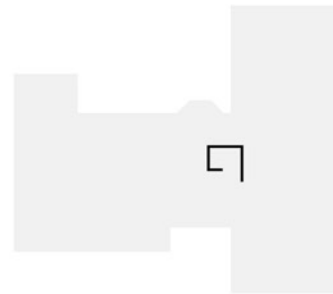

From Car to Fridge
32'-0" (7.1 secs)



Covered Outdoor Spaces
444 sf / 25%

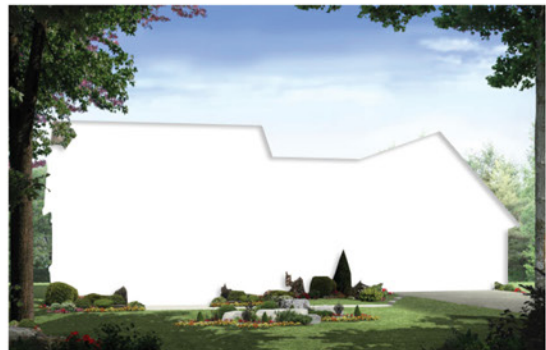

Nature

The Andrea Joyce

—
#2 Best-Seller



56

<u>Identification</u>	<u>Sq Ft</u>	<u>Beds</u>	<u>Exterior Style</u>	<u>Features</u>	<u>Plan Pricing</u>
THD-HDS-4718	1730	3	Contemporary	2-Car Garage	\$800.00 (PDF)
	<u>Stories</u>	<u>Bath</u>	Craftsman	Breakfast Nook	
	1	3	Traditional	Fireplace	
			Mountain		
			Vacation		

Store House



Storage, First Floor
190 sf / 11%



Master vs Bedrooms
30'-9" between wings



Covered Outdoor Spaces
613 sf / 36%



From Car to Fridge
23'-6" (5.2 secs)



Nature

L'Attesa di Vita

#1 Best-Seller



58

<u>Identification</u>	<u>Sq Ft</u>	<u>Beds</u>	<u>Exterior Style</u>	<u>Features</u>	<u>Plan Pricing</u>
THD-EXB-1895	2091	3	Mountain Vacation Ranch Cottage Craftsman	2-Car Garage BBQ Porch Bonus Room Breakfast Nook Fireplace Study	\$1245.00 (PDF)
	<u>Stories</u>	<u>Bath</u>			
	1	2.5			

Store House



Storage, First Floor
207 sf / 10%



Master vs Bedrooms
41'-6" between wings



Covered Outdoor Spaces
654 sf / 31%

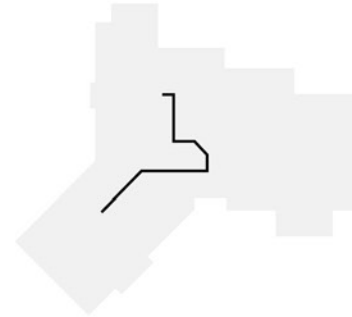

From Car to Fridge
60'-0" (13.3 secs)



Nature

Suburban-Spatial Commandments

— The Findings

60

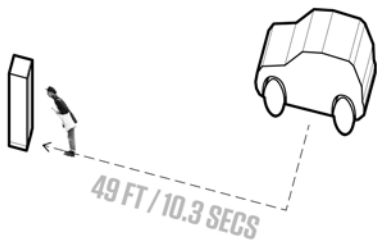

Rule #1

The fridge should be no more than 49 feet from the parked car.

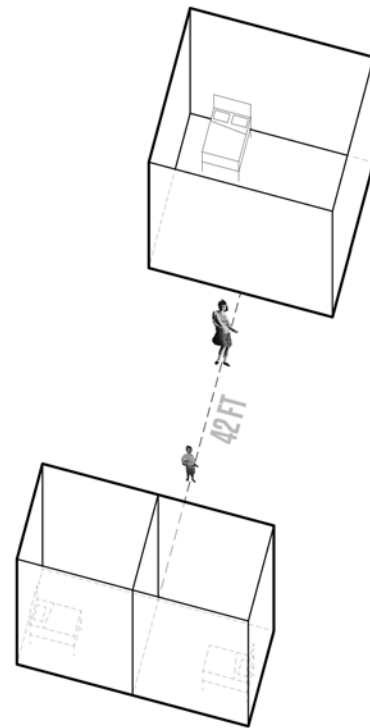

Rule #2

The bedrooms should be placed on the opposite side of the house from the master suite—approximately 42 feet away. Typically the communal residential programs are used as a buffer between these two zones.

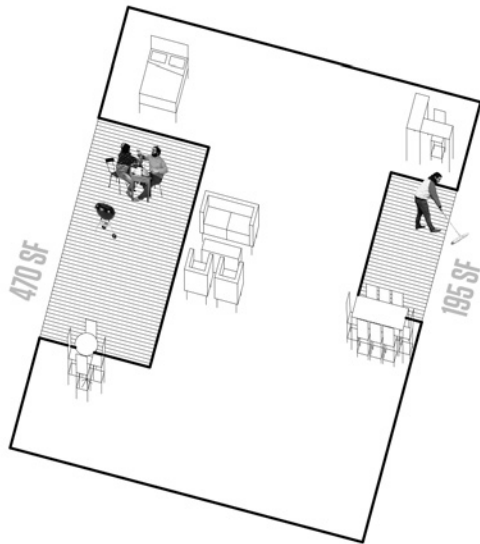

Rule #3

The home should have a front and rear porch. At least one—but preferably both—should be covered. The rear porch should be approximately twice the size of the front porch. Both spaces typically notch into the home to create additional windows with semi-private views.

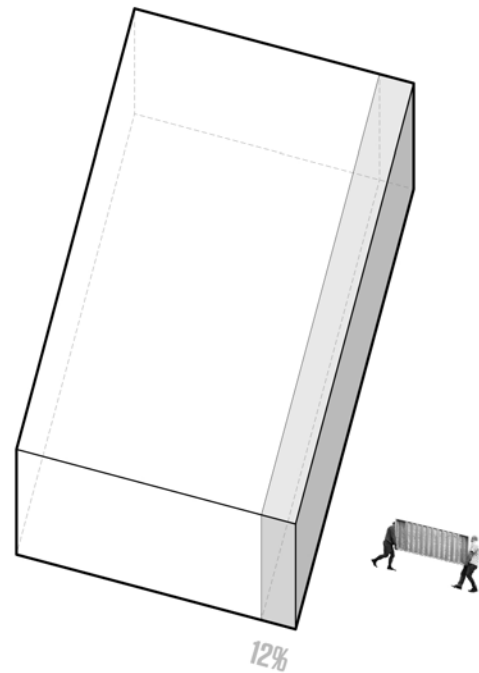

Rule #4

12% of the floor plan should be devoted to enclosed storage spaces. This includes pantries; linen, utility & walk-in closets; and designated storage rooms. This does not include casework, garage space, basements or bonus rooms.

A SPECTRUM OF COLLECTIVITY

The Disciplinary Lineage

The history of architecture is a rich repository of different attitudes about collectivity in residential space. This section uses the houses studied in the previous section as case studies that define one end of a spectrum of collectivity, and builds upon them to reveal how sharing has been used historically within the space of the home.

If the best-selling floor plans are viewed as a collection of “single-serving spaces,” fulfilling the needs of the inhabitants of one unit and sharing nothing, then the remaining points on the spectrum can be seen as representative of three distinct attitudes about collectivity within multi-unit dwellings. The first preserves the autonomy of each unit but has the potential to share key infrastructures, most of which are abstract to the occupant. For example, mechanical runs may be shared, but because of their location within the thickness of the wall, this sharing is not symbolically or experientially significant. The second allows for sharing between adjacent units but—while certain amenities are shared within these projects—the scale of the sharing never moves beyond two or three units. The third and final provides, generally centralized, spaces for sharing across many or all units.

The Mailbox

—



Standard US
Residential Postal Box

For the individual in
a detached home



Mail Slot

For the individual within
multi-family housing

Store House



Multi-Tenant
Mailbox

For several units to share
within multi-family housing

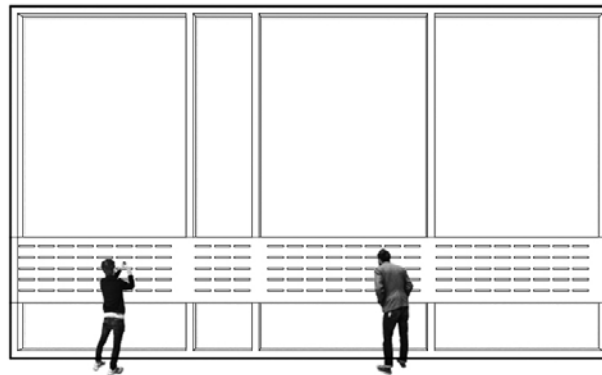

WoZoCo Housing,
MVRDV

For all units to share within
multi-family housing

The Garage



L'Atessa di Vita House

For the individual in
a detached home

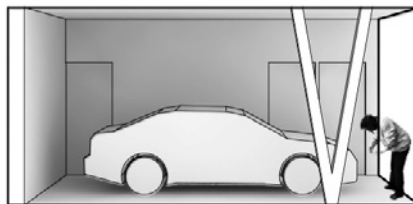

Eindhoven Townhouses,
Grosfeld Architekten

For the individual within
multi-family housing

Store House



Huizen,
Neutelings Riedijk

For several units to share
within multi-family housing

The Front Yard

—

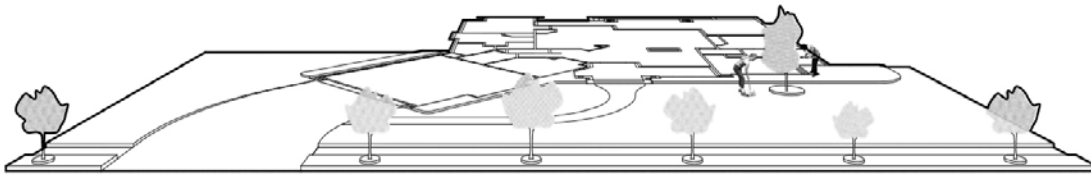

L'Atessa di Vita House

For the individual in
a detached home

68

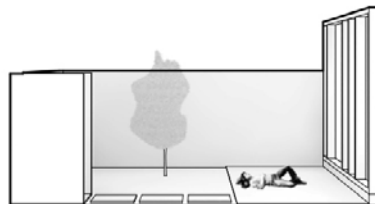

Maiden Lane Housing,
Benson Forsyth

For the individual within
multi-family housing

Store House

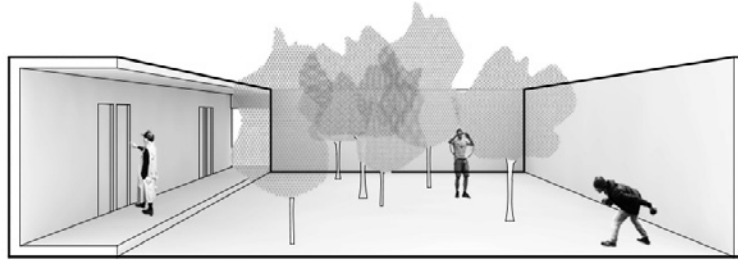

San Sebastian de los Reyes,
SMAQ

For several units to share
within multi-family housing

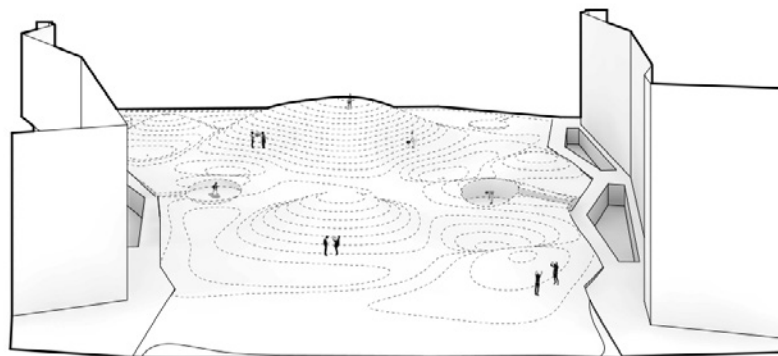

Robin Hood Gardens,
Alison & Peter Smithson

For all units to share within
multi-family housing

The Front Porch

—



L'Atessa di Vita House

For the individual in
a detached home

70

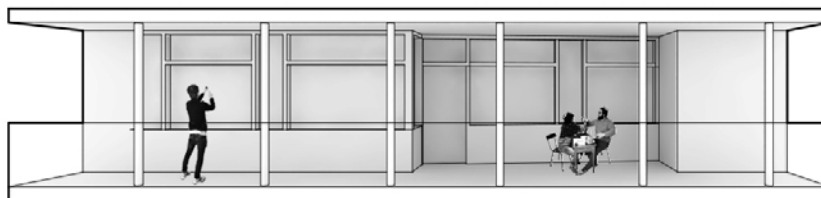

Bülachhof,
Langenegger

For the individual within
multi-family housing

Store House

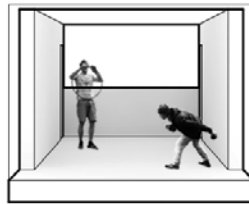

Gifu Kitagata Housing,
Kazuya Sejima

For several units to share
within multi-family housing

71

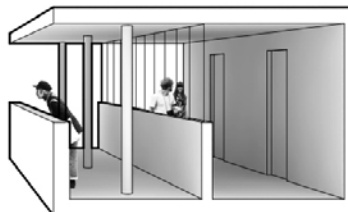

Narkomfin Social Housing,
Moisej Ginzburg

For all units to share within
multi-family housing

The Front Door

—



L'Atessa di Vita House

For the individual in
a detached home

72



Seijo Townhouses,
SANAA

For the individual within
multi-family housing

Store House



Full Stop & Comma Townhouses,
Alvaro Siza

For several units to share
within multi-family housing

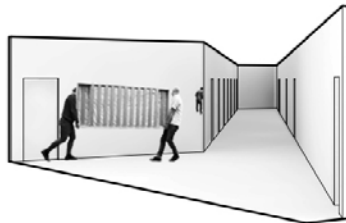

M House,
BIG + JDS

For all units to share within
multi-family housing

The Back Porch

—

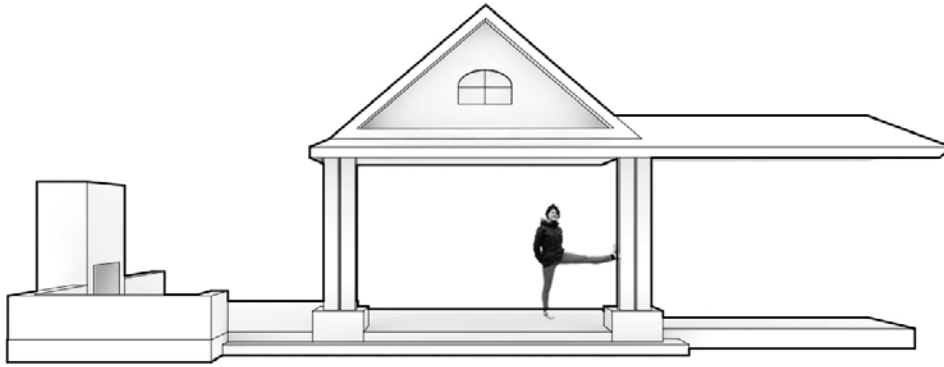

L'Atessa di Vita House

For the individual in
a detached home

74

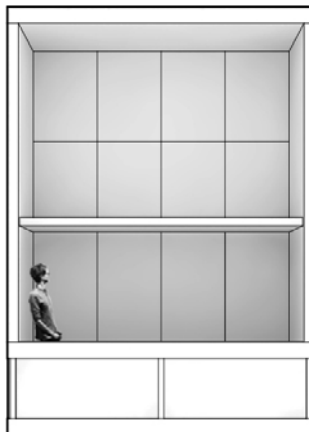

Unite d'Habitation, Le Corbusier

For the individual within
multi-family housing

Store House



Rue des Suisses Housing,
Herzog & de Meuron

For several units to share
within multi-family housing

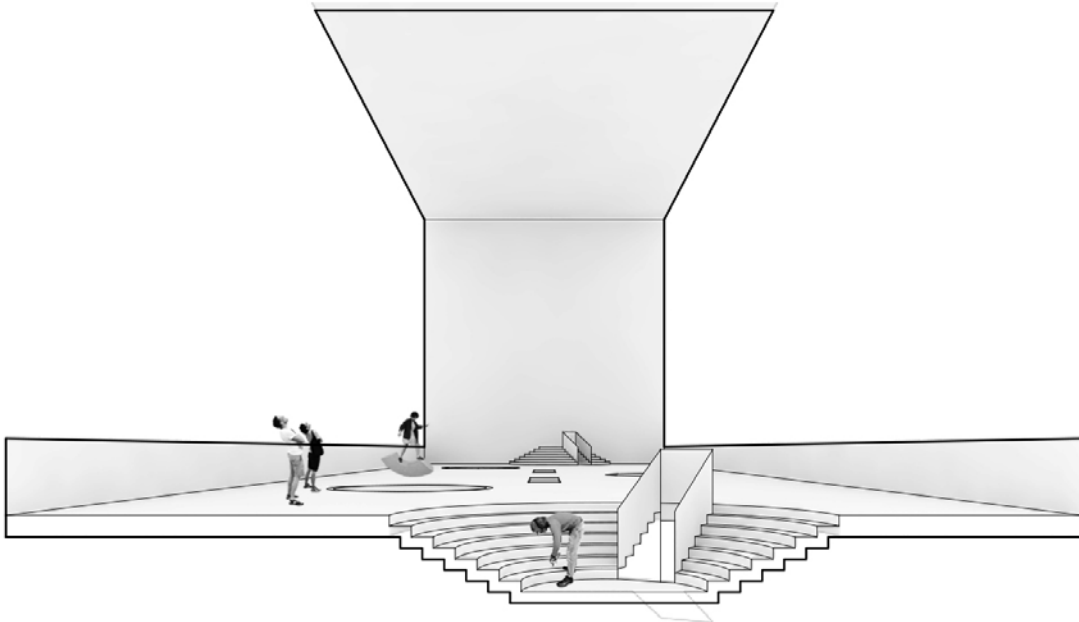

Mirador Housing,
MVRDV

For all units to share within
multi-family housing

The Back Yard

—

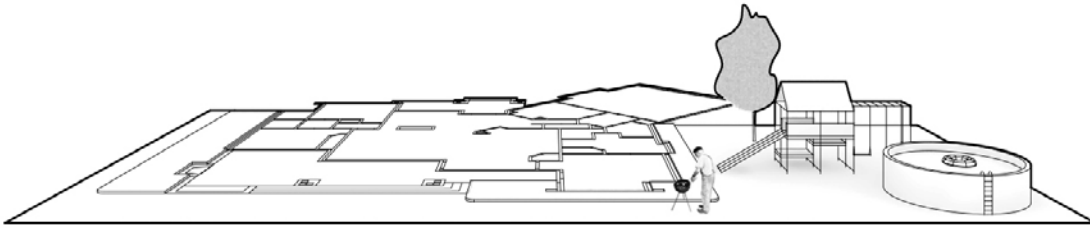

L'Atessa di Vita House

For the individual in
a detached home

76

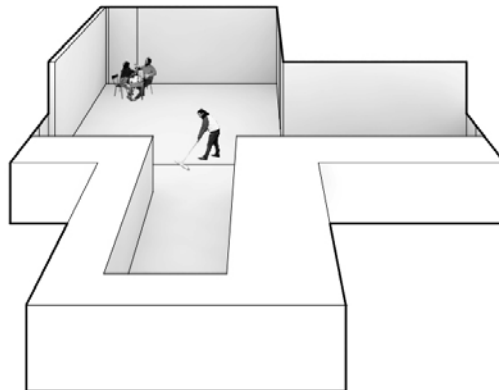

Mountain Dwellings, BIG + JDS

For the individual within
multi-family housing

Store House

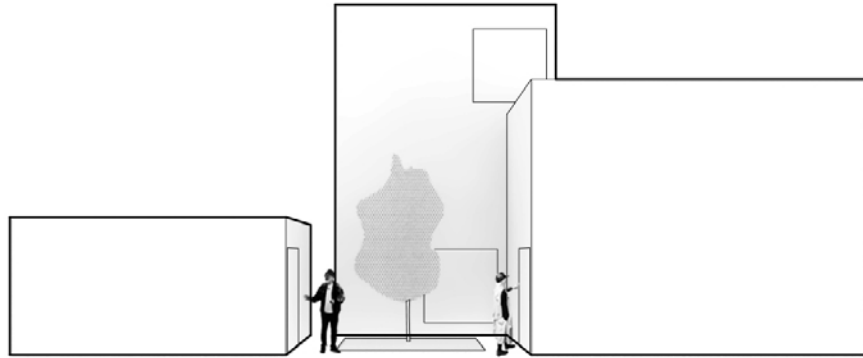

Seijo Townhouses,
SANAA

For several units to share
within multi-family housing

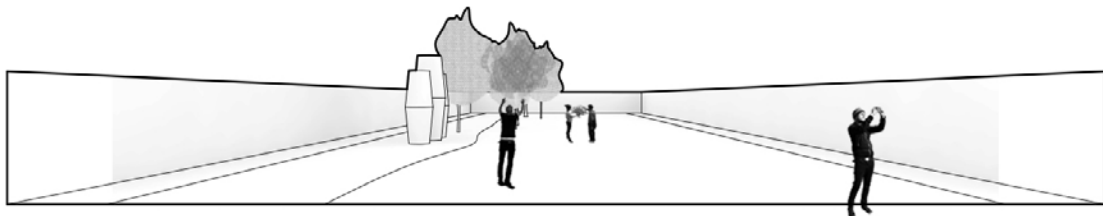

The Whale Housing,
de Architecten Cie

For all units to share within
multi-family housing

DISMANTLING THE HOUSE

The Design Methodology

How could one rearrange domestic space to leverage communal opportunities while preserving many of the conventional notions of ownership and privacy present in the American suburbs? In the previous studies, there were no examples that moved inside the walls of the home itself. None of the communal programs explicitly effected the space of domesticity. By virtue of that, the effect they have on how people's lives is correspondingly minimal. While the space outside of the home may be substantively transformed, the space of the home itself remains architecturally unchanged. What architectural and spatial opportunities are hiding in plain sight?

If one's ambition is to refashion the space of the home from within, a new methodology for accomplishing this is needed. In this case, the best-selling home, *L'Atessa di Vita*, was used as an architectural tangram for studying programmatic possibility. It was broken apart into over twenty pieces ranging in scale from the linen closet to the front yard. Initially these pieces were shuffled as a way of identifying new possibilities for sharing within a single unit (for example, sharing a closet between adjacent bedrooms). As the investigation progressed the boundaries of the inquiry shifted from the single to the double to the quartet and eventually to the octet. The potential for multiple, simultaneous scales of sharing grew with each jump in scale. The next few pages describe these opportunities in greater detail.

Getting to Know Number One

—
L'Atessa di Vita

The drawings below show a digital model of L'Atessa di Vita with inscribed lines indicating the places at which they were cut to create the individual components.

On the next spread, you see an investigation of sharing at the smallest single and “multi-unit” scales (the duplex). Certain potentials reveal themselves at the scale of the two that are not available at the one: the arrows crossing the spine of the book—on the next spread—signify these opportunities.

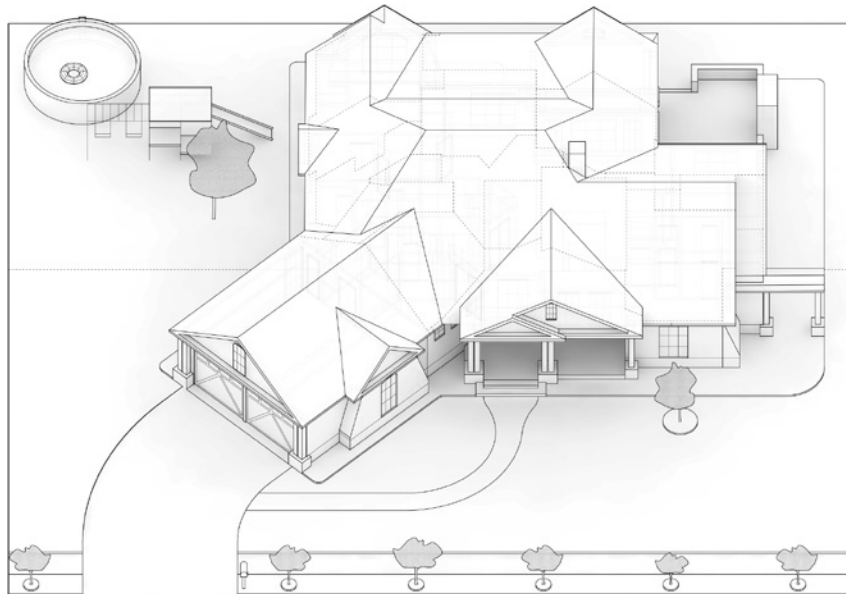

Store House

Key for Next Spread

01 Front Yard	12 Bedroom #3
02 Front Porch	13 Bathroom
03 Front Door	14 Linen Closet
04 Mailbox	15 Fireplace
05 Garage	16 Master Bathroom
06 Bonus Room	17 Master Bedroom
07 Half Bathroom	18 Walk-in Closet
08 Mud Room	19 Great Room
09 Office	20 Kitchen
10 Dining Room	21 Back Porch
11 Bedroom #2	22 Back Yard

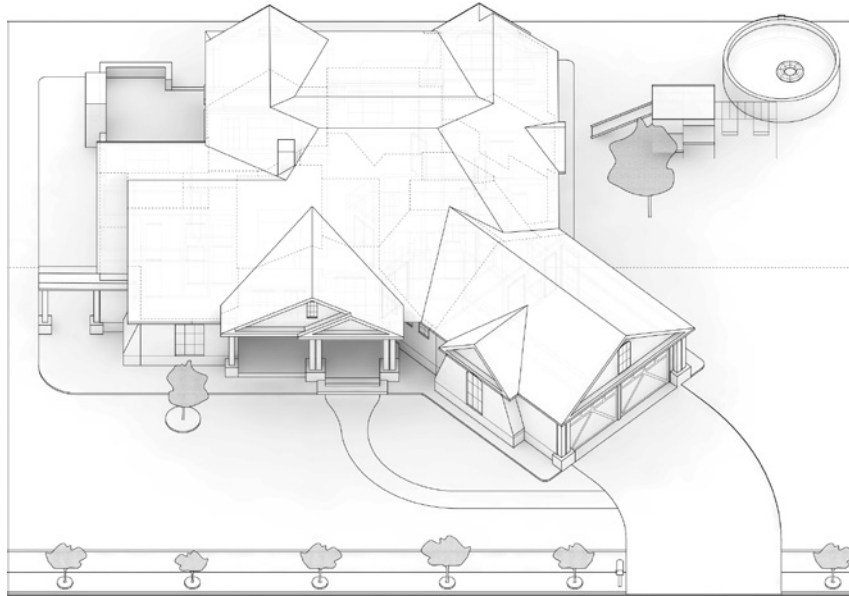

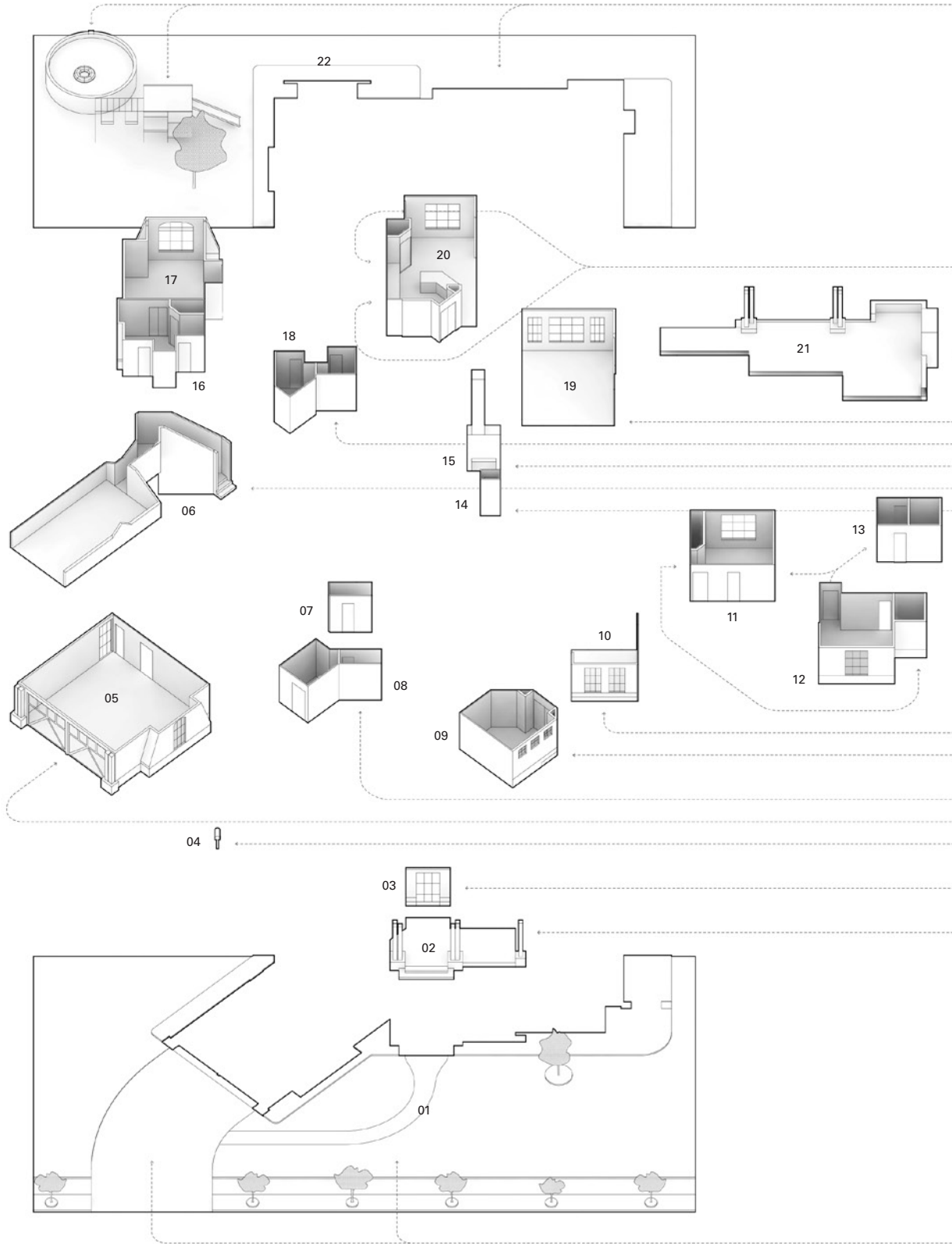

Store House

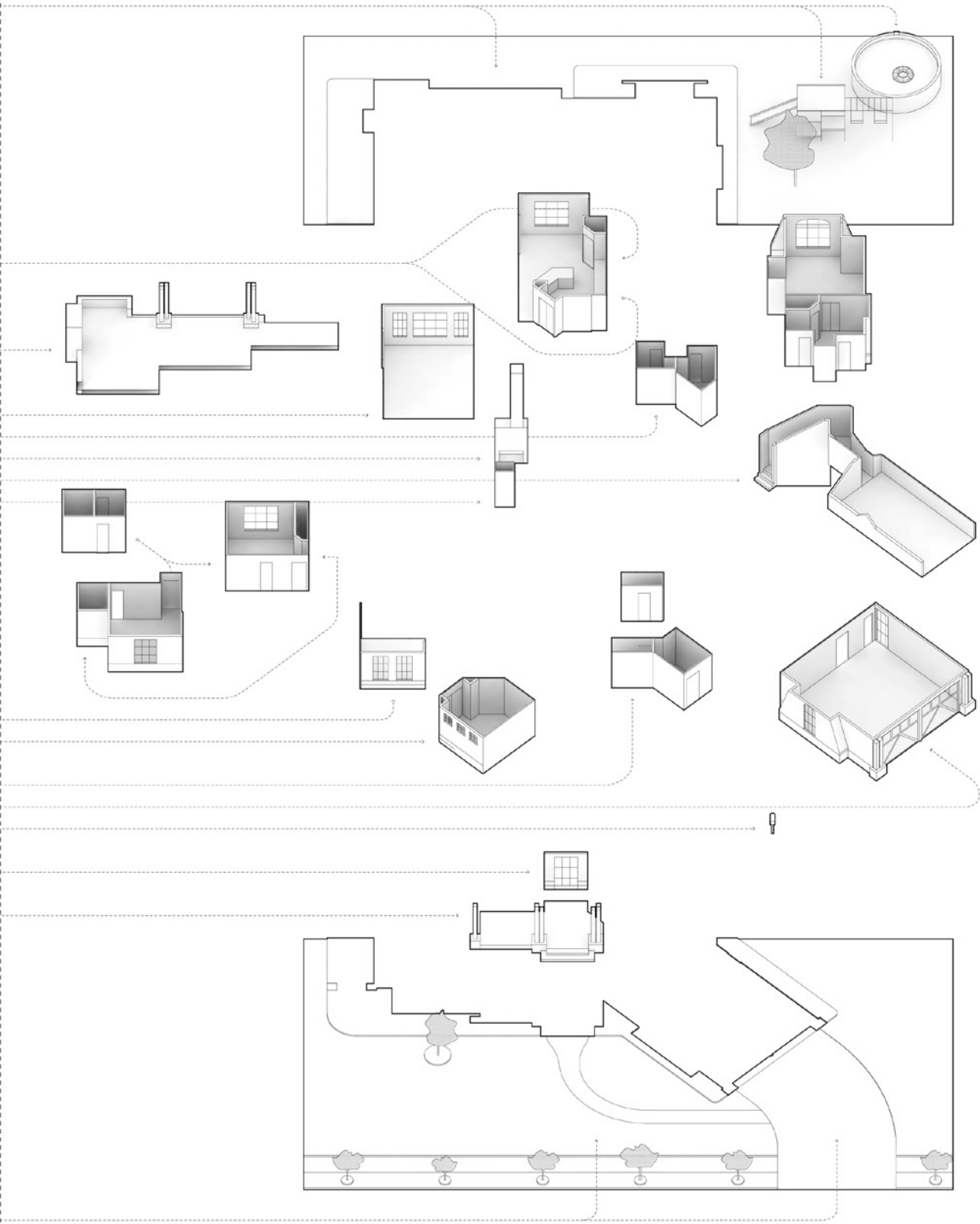

Quadplex

—
 This image shows the components of L'Atessa di Vita (shown on the previous page) multiplied by four and rearranged to create opportunities for sharing across a four-unit complex. The upper half of the drawing shows plan information while the lower half shows axonometric detail.

The darker blue is used to indicate the interior spaces within one unit that have the potential for sharing with neighboring units. The lighter blue represents the spaces outside of the unit that it could engage through sharing.

The following list details the shared zones and outlines a few programmatic possibilities for this sharing:

- 01 Shared Garage (2 units)
 Potential: a communal car fleet, shared workshop
- 02 Shared Bonus Room, spanning Shared Garage & Offices (2 units)
 Potential: shared children's playroom, workshop, office space or guest suite
- 03 Shared Dining Room (2 units)
 Potential: place for shared meals, party space, meeting space
- 04 Shared Kitchen (4 units)
 Potential: shared pantry, shared wall and/or floor cabinets, peek-a-boo window above sink, "rent an oven" for special occasions, shared informal dining

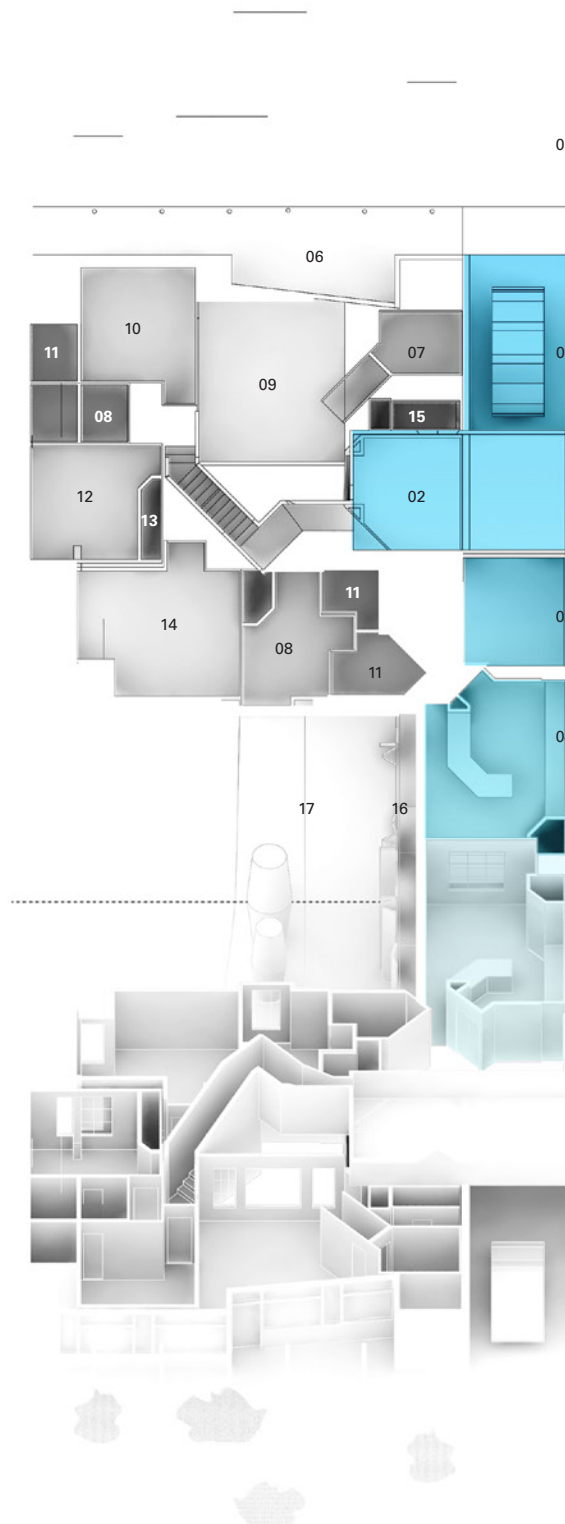

Store House

Components from L'Atessa di Vita,
unless noted below

- 01 Garage
from Huizen,
Neutelings Riedijk
- 02 Bonus Room
above Office & Garage
- 03 Dining Room
- 04 Kitchen
- 05 Front Yard
from San Sebastian de
los Reyes, SMAQ
- 06 Front Porch
from Bülachhof,
Langenegger
- 07 Entry
- 08 Master Bathroom
- 09 Great Room
- 10 Bedroom #2
- 11 Walk-in Closet
- 12 Bedroom #3
- 13 Closet
- 14 Master Bedroom
- 15 Bathroom
- 16 Back Porch
from Rue des Suisses,
Herzog & De Meuron
- 17 Back Yard
from the Whale,
Neutelings Riedijk

See previous section for individual
drawings of each component.

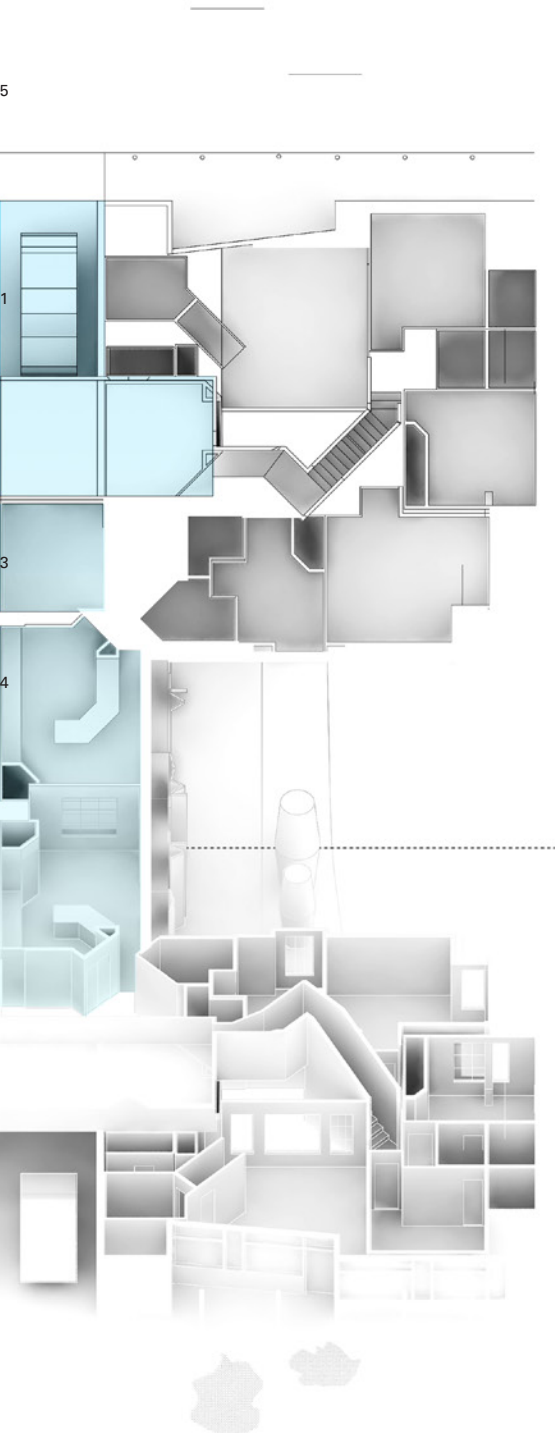

Octaplex #1

—
 This image shows the components of L'Atessa di Vita multiplied by eight and rearranged to create opportunities for sharing across an eight-unit complex. The upper half of the drawing shows plan information while the lower half shows axonometric detail.

The darker blue is used to indicate the interior spaces within one unit that have the potential for sharing with neighboring units. The lighter blue represents the spaces outside of the unit that it could engage through sharing.

The following list details the shared zones and outlines a few programmatic possibilities for this sharing:

- 01 Shared Patio (2 units)
 Potential: shared bbq, shared dining
- 02 Shared Great Room
 Potential: shared hearth, party space, movie screening / performance / dance / fitness space, communal meeting space
- 03 Shared Kitchen (4 units)
 Potential: shared pantry, shared wall and/or floor cabinets, peek-a-boo window above sink, "rent an oven" for special occasions, shared informal dining
- 04 Shared Dining Room (2 units)
 Potential: place for shared meals, party space, meeting space

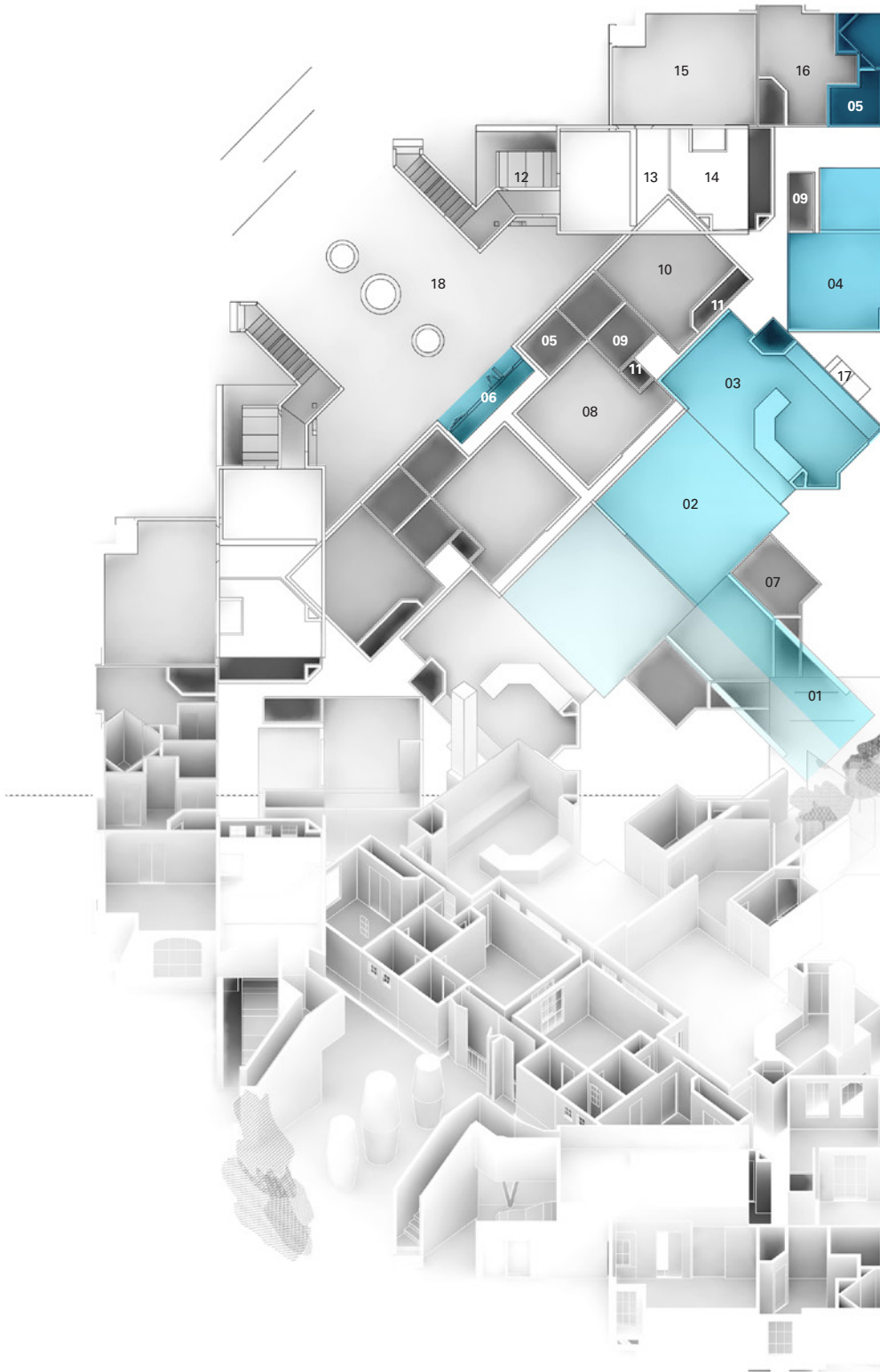

Store House

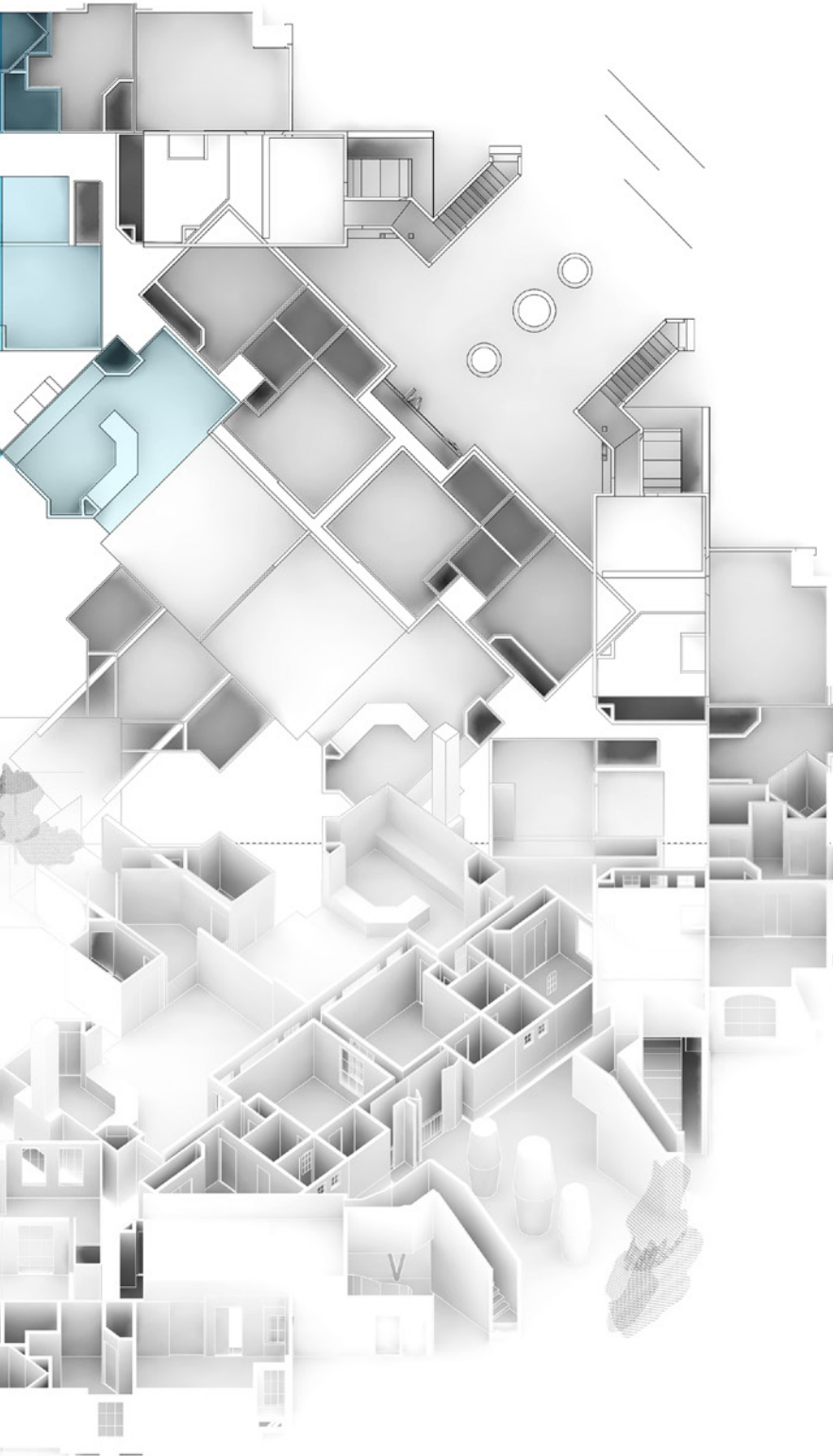

05 Shared Walk-In Closet (2 units)

Potential: shared wardrobe, space for "lifestyle pods" (see Outtakes & Experiments)

06 Shared Porch (2 units)

Potential: siesta space

Components from L'Atessa di Vita,
unless noted below

- 01 Entry from
Gifu Kitagata Housing,
Kazuya Sejima
- 02 Great Room
- 03 Kitchen
- 04 Dining Room
- 05 Walk-in Closet
- 06 Porch
from Rue des Suisses,
Herzog & De Meuron
- 07 Entry
- 08 Bedroom #2
- 09 Bathroom
- 10 Bedroom #3
- 11 Closet
- 12 Garage from
Eindhoven Townhouses,
Grosfeld Architecten
- 13 Bonus Room
above Office & Garage
- 14 Office (below)
- 15 Master Bedroom
- 16 Master Bathroom
- 17 Fireplace
- 18 Back Yard
from the Whale,
Neutelings Riedijk

See previous section for individual
drawings of each component.

Octaplex #2

—
 This image shows the components of L'Atessa di Vita multiplied by eight and rearranged to create opportunities for sharing across an eight-unit complex. The upper half of the drawing shows plan information while the lower half shows axonometric detail.

The darker blue is used to indicate the interior spaces within one unit that have the potential for sharing with neighboring units. The lighter blue represents the spaces outside of the unit that it could engage through sharing.

The following list details the shared zones and outlines a few programmatic possibilities for this sharing:

- 01 Shared Garage (2 units)
 Potential: a communal car fleet, shared workshop
- 02 Shared Office (2 units)
 Potential: shared children's playroom, workshop, office space
- 03 Shared Walk-In Closet (2 units)
 Potential: shared wardrobe, space for "lifestyle pods" (see Outtakes & Experiments)
- 04 Shared Dining Room (2 units)
 Potential: place for shared meals, meeting space
- 05 Shared Kitchen (4 units)
 Potential: shared pantry, shared wall and/or floor cabinets, peek-a-boo window above sink, "rent an oven" for special occasions, shared informal dining

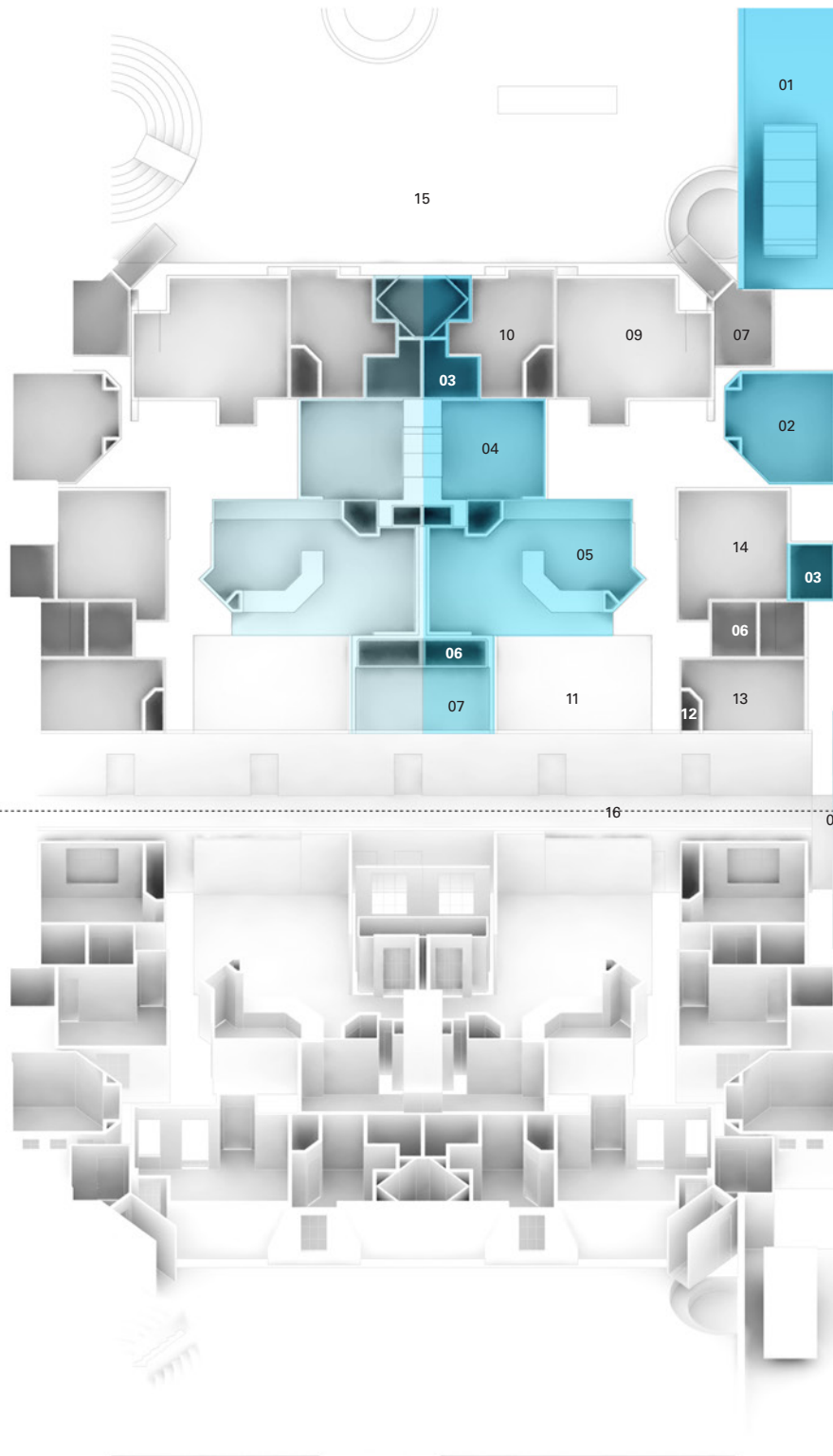

Store House

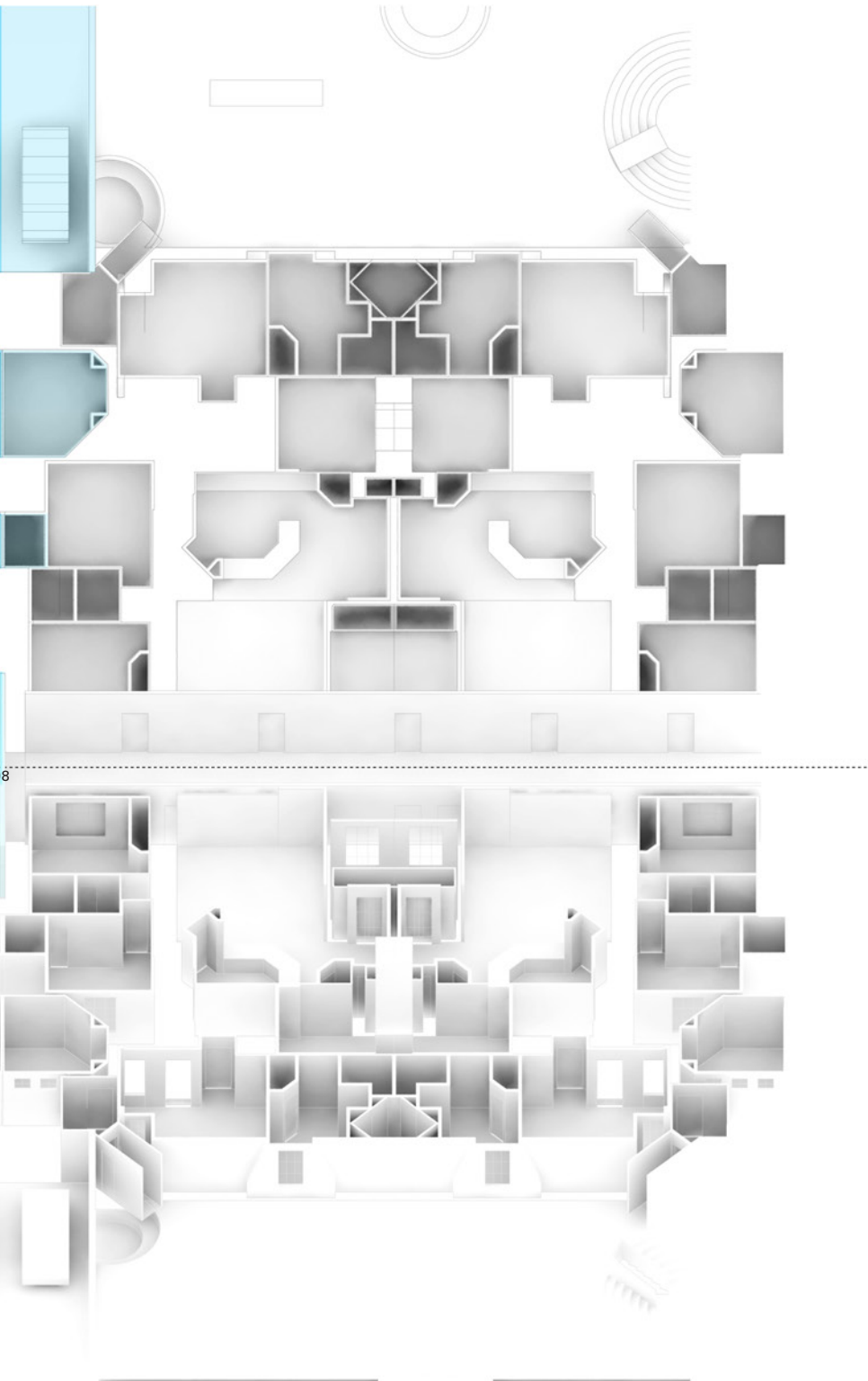

06 Shared Bathroom (2 units)

Potential: shared sauna

07 Shared Entry (2 units)

Potential: shared children's playroom, shared mudroom, laundry facility

Components from L'Atessa di Vita, unless noted below

01 Garage

from Huizen, Neutelings Riedijk

02 Office

03 Walk-In Closet

04 Dining Room

05 Kitchen

06 Bathroom

07 Entry

08 Mail

from WoZoCo Housing, MVRDV

09 Master Bedroom

10 Master Bathroom

11 Great Room

12 Closet

13 Bedroom #2

14 Bedroom #3

15 Back Yard

from Mirador Housing, MVRDV

16 Corridor

from M-House, BIG + JDS

See previous section for individual drawings of each component.

Octaplex #3

—
 This image shows the components of L'Atessa di Vita multiplied by eight and rearranged to create opportunities for sharing across an eight-unit complex. The upper half of the drawing shows plan information while the lower half shows axonometric detail.

The darker blue is used to indicate the interior spaces within one unit that have the potential for sharing with neighboring units. The lighter blue represents the spaces outside of the unit that it could engage through sharing.

The following list details the shared zones and outlines a few programmatic possibilities for this sharing:

- 01 Shared Bonus Room, above Shared Garage (2 units)
 Potential: shared children's playroom, workshop, office space or guest suite
- 02 Shared Garage (2 units)
 Potential: a communal car fleet, shared workshop, shared laundry
- 03 Shared Great Room
 Potential: shared hearth, party space, movie screening / performance / dance / fitness space, communal meeting space
- 04 Shared Dining Room (2 units)
 Potential: place for shared meals, meeting space
- 05 Shared Kitchen (2 units)
 Potential: shared pantry, shared wall and/or floor cabinets, peek-a-boo window above sink, "rent an oven" for special occasions, shared informal dining

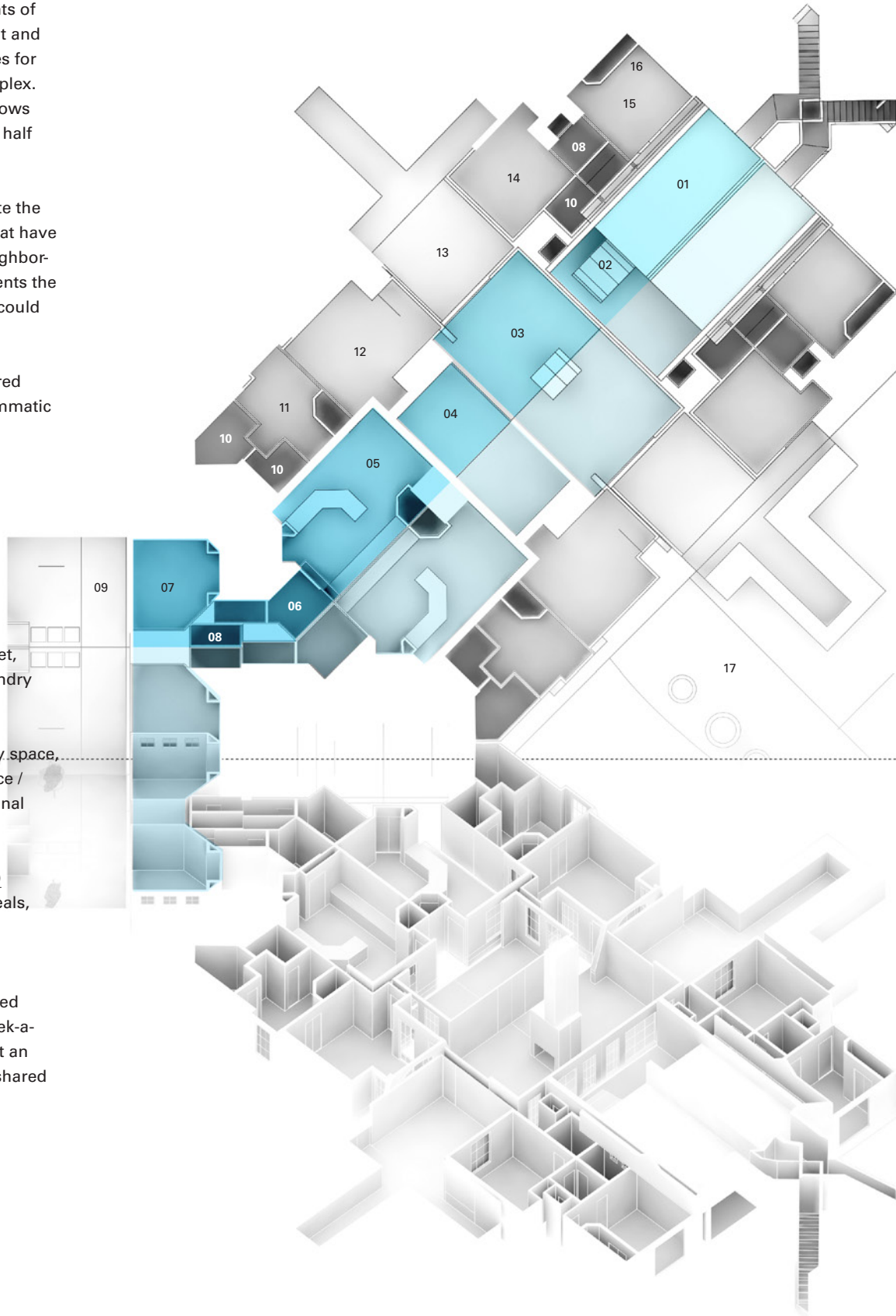

Store House

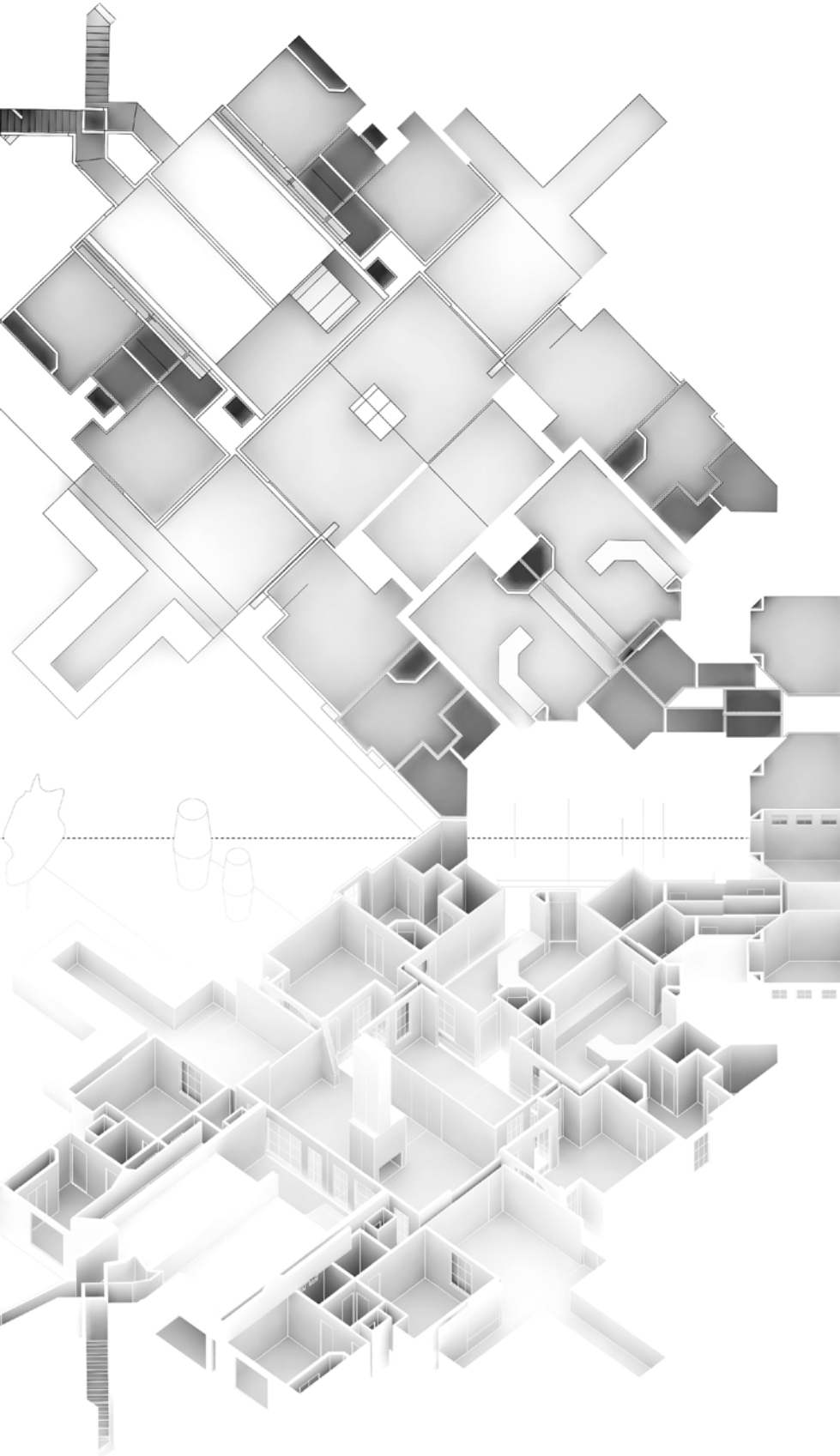

06 Shared Entry

Potential: shared coat closet,
shared greenhouse

07 Shared Office / Secondary Suite

Potential: collaborative work space,
rentable space, "mother-in-law"
apartment, guest suite

08 Shared Bathroom (2 units)

Potential: shared sauna

Components from L'Atessa di Vita,
unless noted below

01 Bonus Room
above Garage

02 Garage
from Huizen,
Neutelings Riedijk

03 Great Room

04 Dining Room

05 Kitchen

06 Entry

07 Office / Secondary Suite

08 Bathroom

09 Front Yard
from Maiden Lane Housing,
Benson Forsyth

10 Walk-in Closet

11 Master Bathroom

12 Master Bedroom

13 Back Porch
from Mountain Dwellings,
BIG + JDS

14 Bedroom #2

15 Bedroom #3

16 Closet

17 Back Yard
from the Whale,
Neutelings Riedijk

See previous section for individual
drawings of each component.

STORE HOUSE

The Architectural Proposal

The methodology outlined in the previous section creates outcomes that are neither pure diagrams—they have dimensions and suggest formal possibilities—nor true architectures—they do not consider natural light or circulation, etc. However, their categorical ambiguity is useful in that it allows them to spark architectural possibilities without dictating all aspects of the design. For example, although the final proposal builds on “Octaplex #3” from the previous section, it transforms it into a two-story complex to introduce the opportunity for sharing in section as well.

The Architectural Proposal

First Floor

Scale 1" = 40'-0"

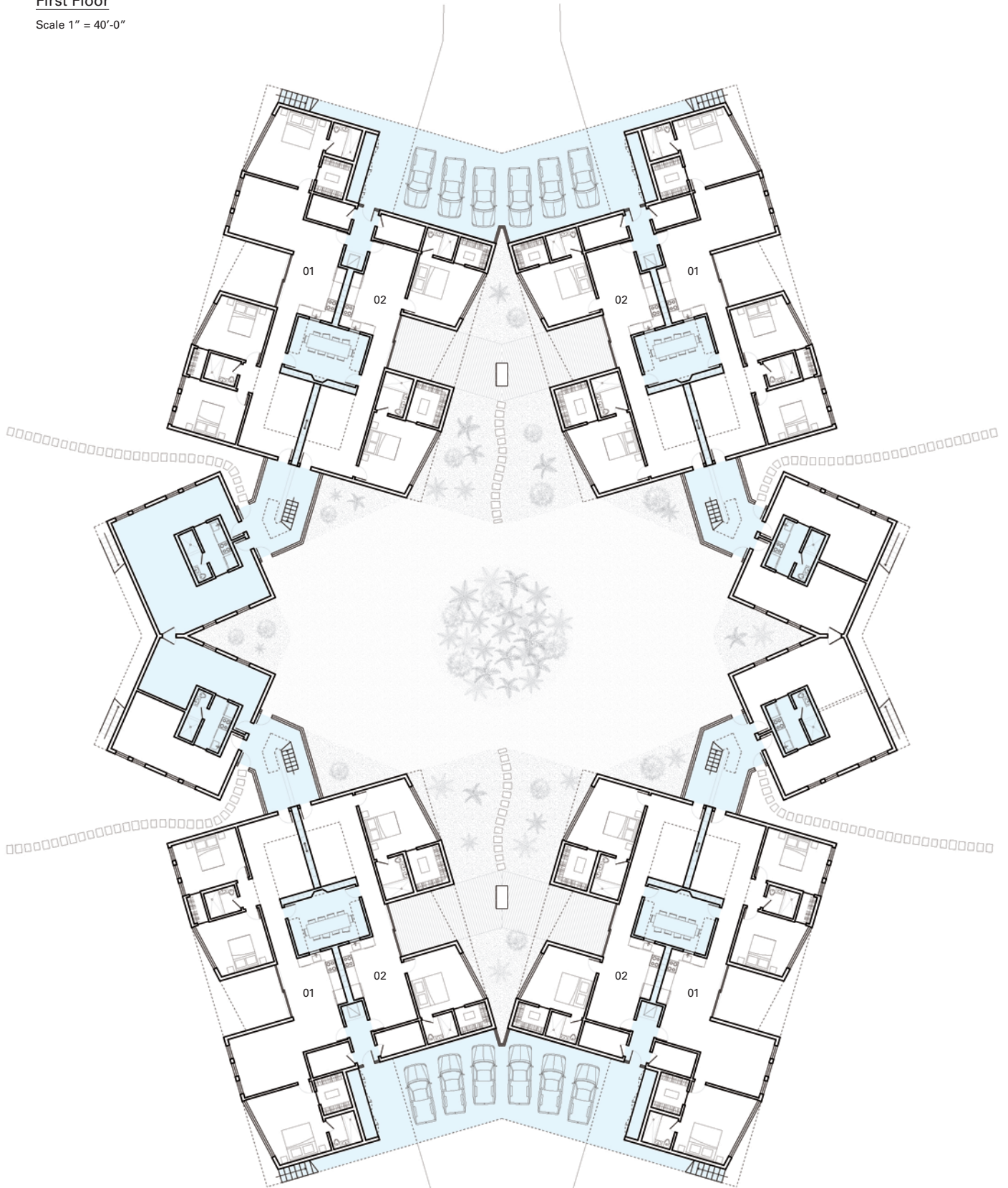

94

01 3-Bedroom Unit
02 2-Bedroom Unit

Store House

Second Floor

Scale 1" = 40'-0"

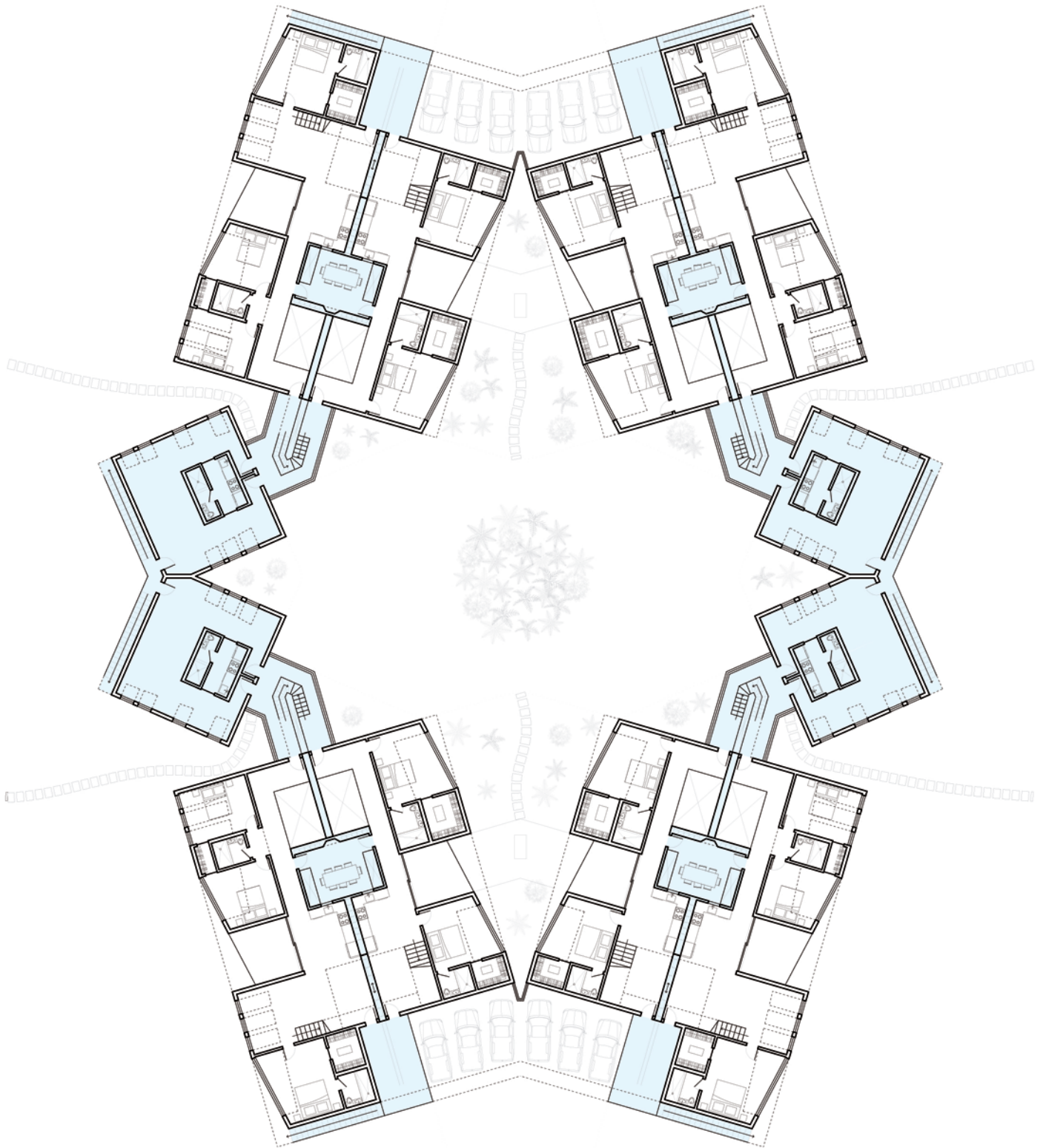

The Architectural Proposal

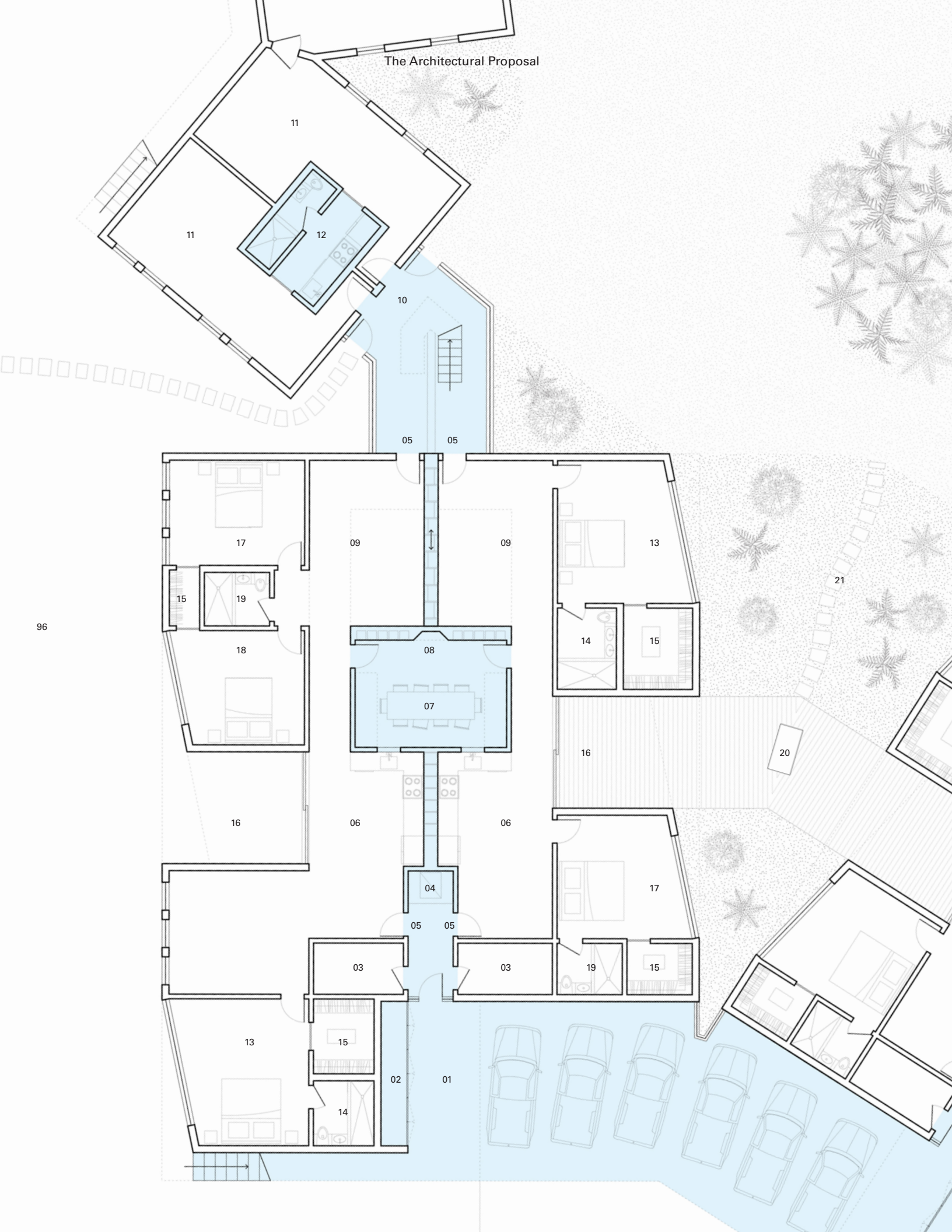

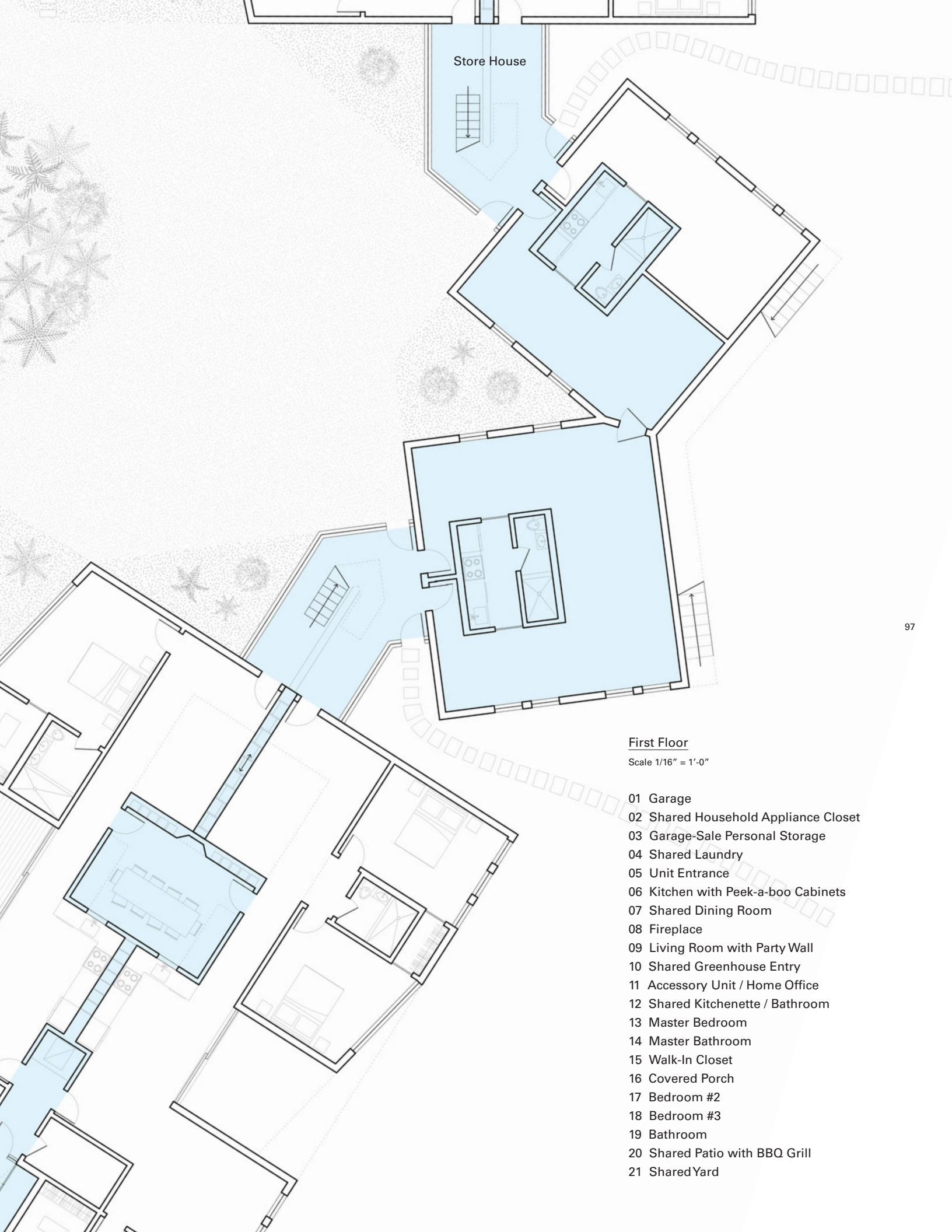

Store House

First Floor

Scale 1/16" = 1'-0"

- 01 Garage
- 02 Shared Household Appliance Closet
- 03 Garage-Sale Personal Storage
- 04 Shared Laundry
- 05 Unit Entrance
- 06 Kitchen with Peek-a-boo Cabinets
- 07 Shared Dining Room
- 08 Fireplace
- 09 Living Room with Party Wall
- 10 Shared Greenhouse Entry
- 11 Accessory Unit / Home Office
- 12 Shared Kitchenette / Bathroom
- 13 Master Bedroom
- 14 Master Bathroom
- 15 Walk-In Closet
- 16 Covered Porch
- 17 Bedroom #2
- 18 Bedroom #3
- 19 Bathroom
- 20 Shared Patio with BBQ Grill
- 21 Shared Yard

The Architectural Proposal

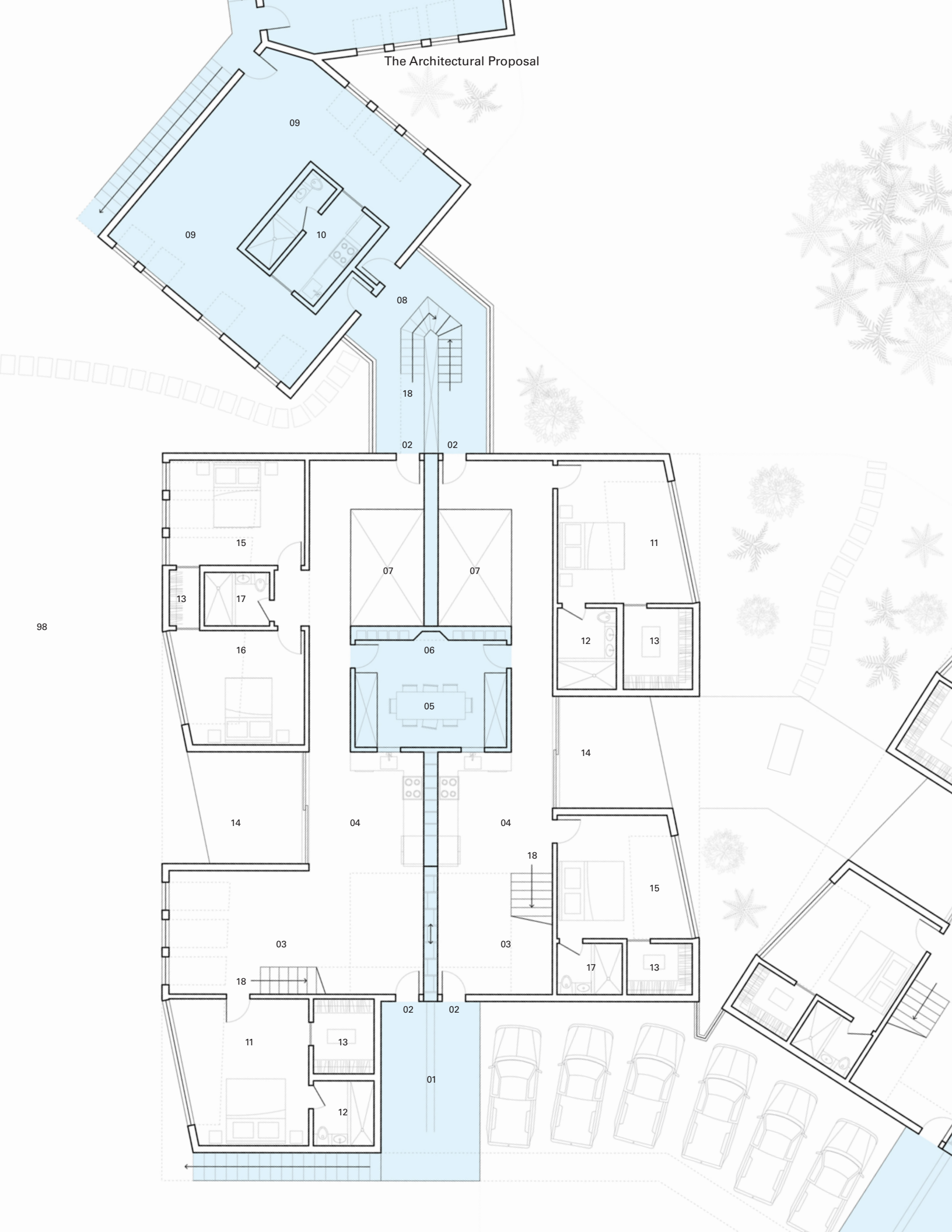

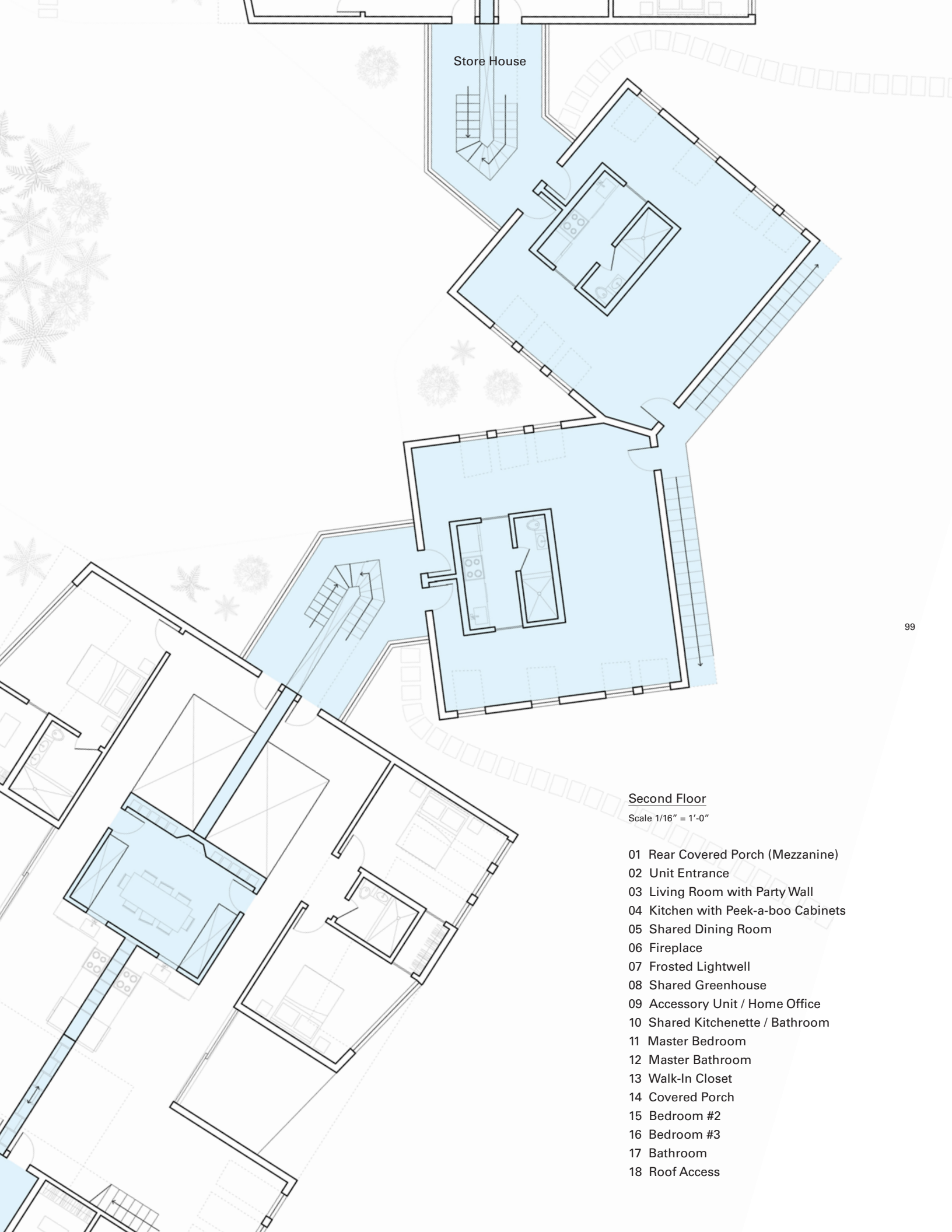

Store House

Second Floor

Scale 1/16" = 1'-0"

- 01 Rear Covered Porch (Mezzanine)
- 02 Unit Entrance
- 03 Living Room with Party Wall
- 04 Kitchen with Peek-a-boo Cabinets
- 05 Shared Dining Room
- 06 Fireplace
- 07 Frosted Lightwell
- 08 Shared Greenhouse
- 09 Accessory Unit / Home Office
- 10 Shared Kitchenette / Bathroom
- 11 Master Bedroom
- 12 Master Bathroom
- 13 Walk-In Closet
- 14 Covered Porch
- 15 Bedroom #2
- 16 Bedroom #3
- 17 Bathroom
- 18 Roof Access





Peek-a-boo Kitchen

—
Because the wall cabinets are shared, occupants can see one another if both open their cabinets simultaneously. In general use, it allows for the sharing of rarely used kitchen gadgets and baking staples (borrowing sugar has never been easier!).

Peek-a-boo Kitchen

—
Because the wall cabinets are shared, occupants can see one another if both open their cabinets simultaneously. In general use, it allows for the sharing of rarely used kitchen gadgets and baking staples (borrowing sugar has never been easier!).

102

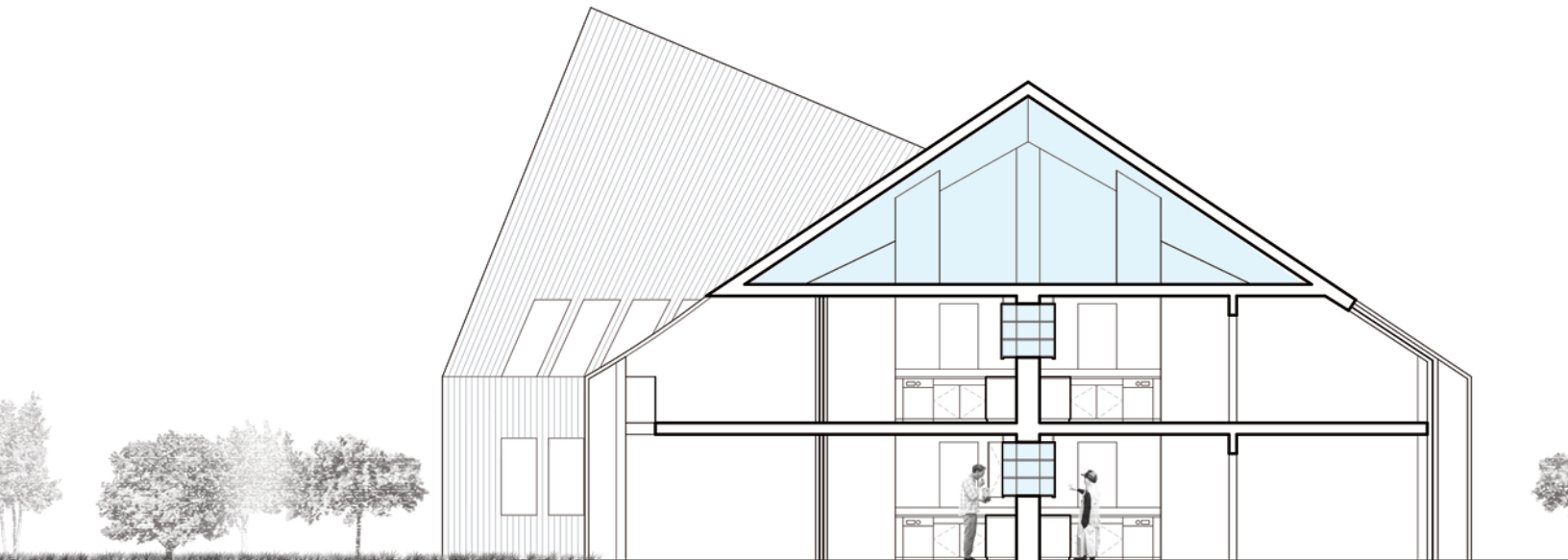

Cross Section through Kitchens

Scale 1/12" = 1'-0"

Store House

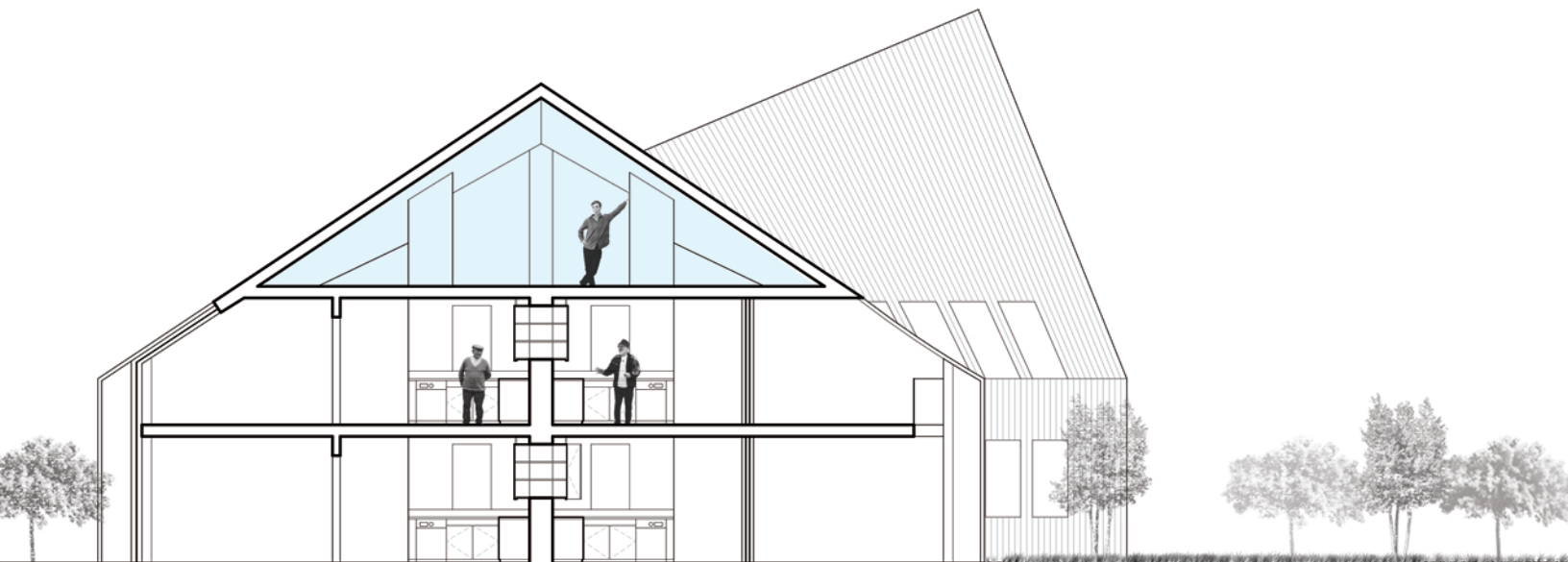
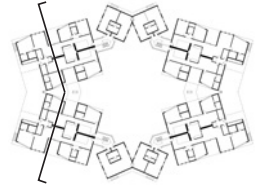

Timeshare Dining / Communal Island

—
In survey after survey home buyers say that they do not want a formal dining room: they don't use it and they'd rather have something in its place. In this project, the dining room becomes a shared space that is simultaneously owned by neither / both parties. Neighbors can decide whether to use the space for shared meals or to devise a schedule so that they never encounter one another.

104

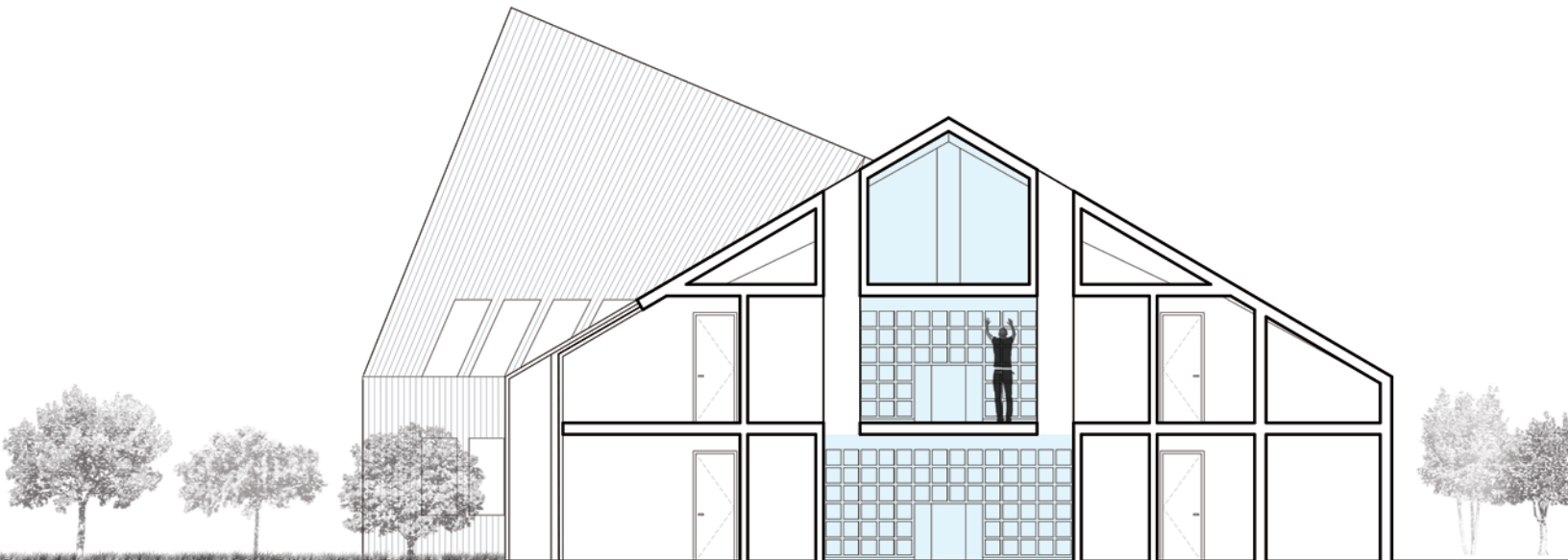

Cross Section through Dining Rooms

Scale 1/12" = 1'-0"

Store House

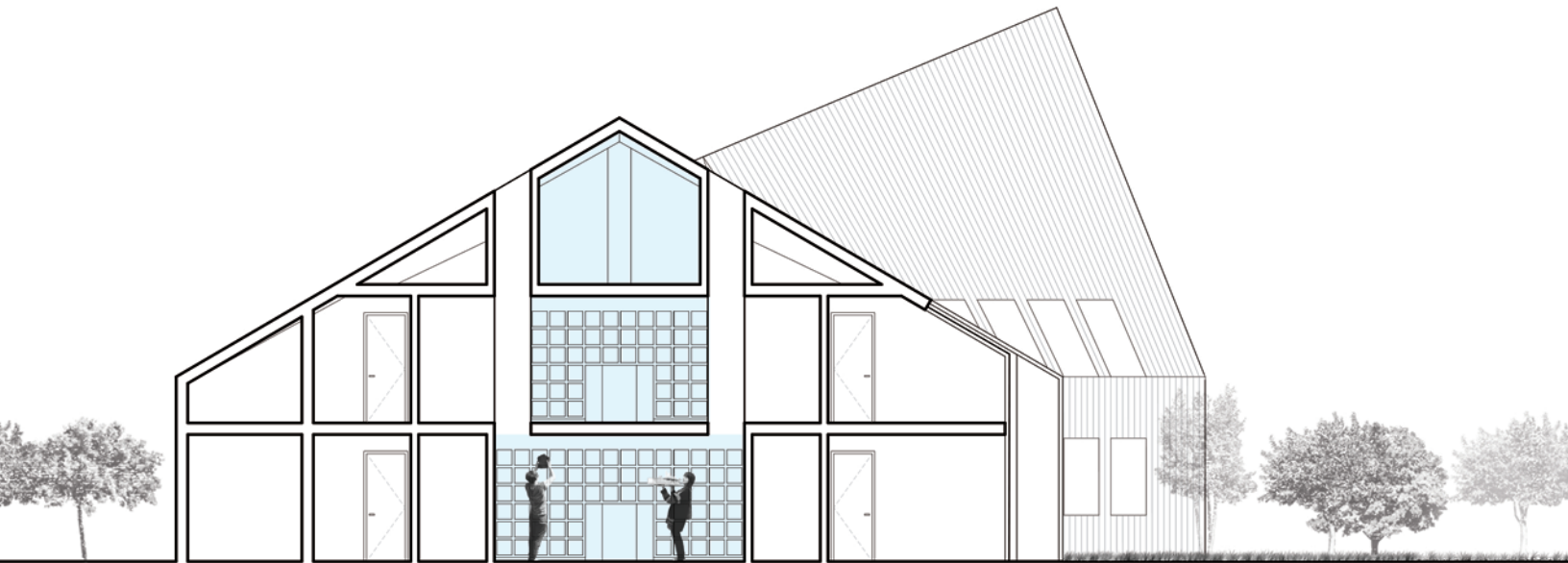
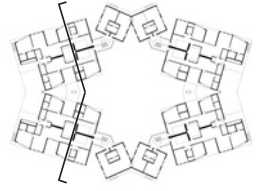

Party Wall Living Room

—
The double-height living room can be completely transformed through sliding the “Party Wall” into the shared greenhouse entry (on the first floor) or the shared back porch (on the second level). By sliding the wall, two distinct spaces are transformed into one larger space for parties or larger social gatherings. This mobile wall allows for programmatic flexibility, but also for changing ownership structures. For example, the wall allows one to buy out a neighbor if their family grows beyond the size of the unit they are currently occupying.

106

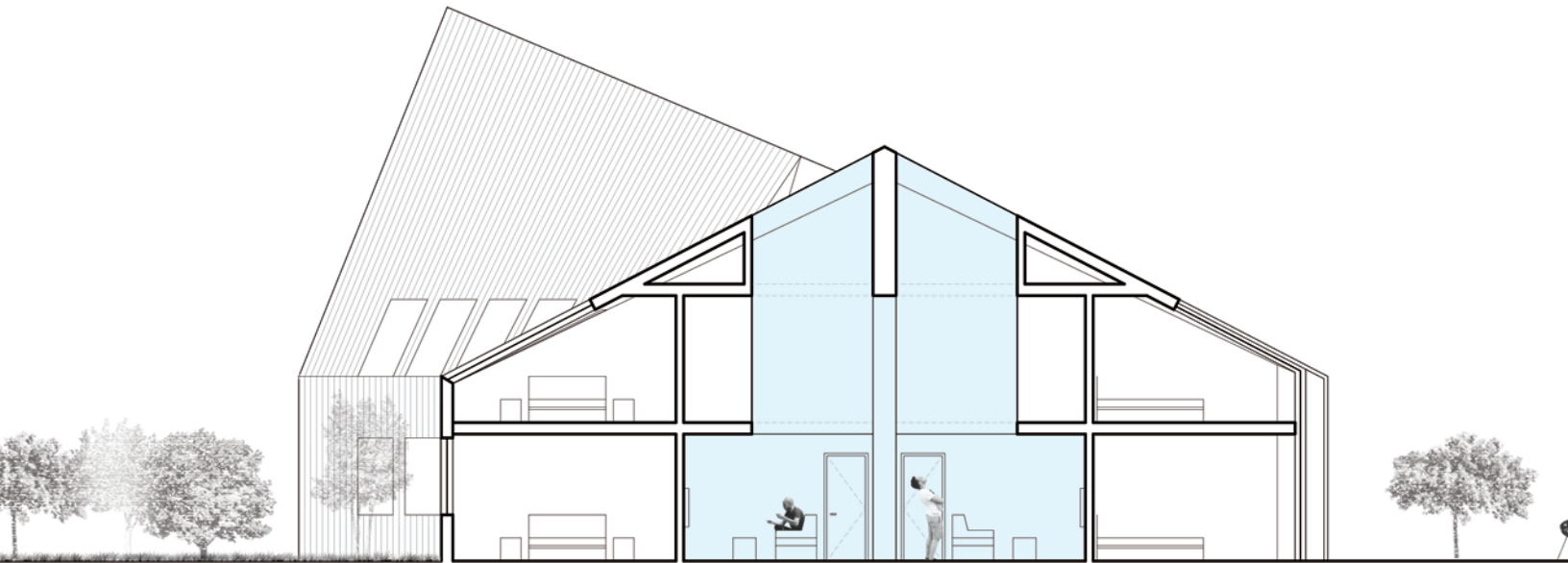

Cross Section through Living Rooms

Scale 1/12" = 1'-0"

Store House

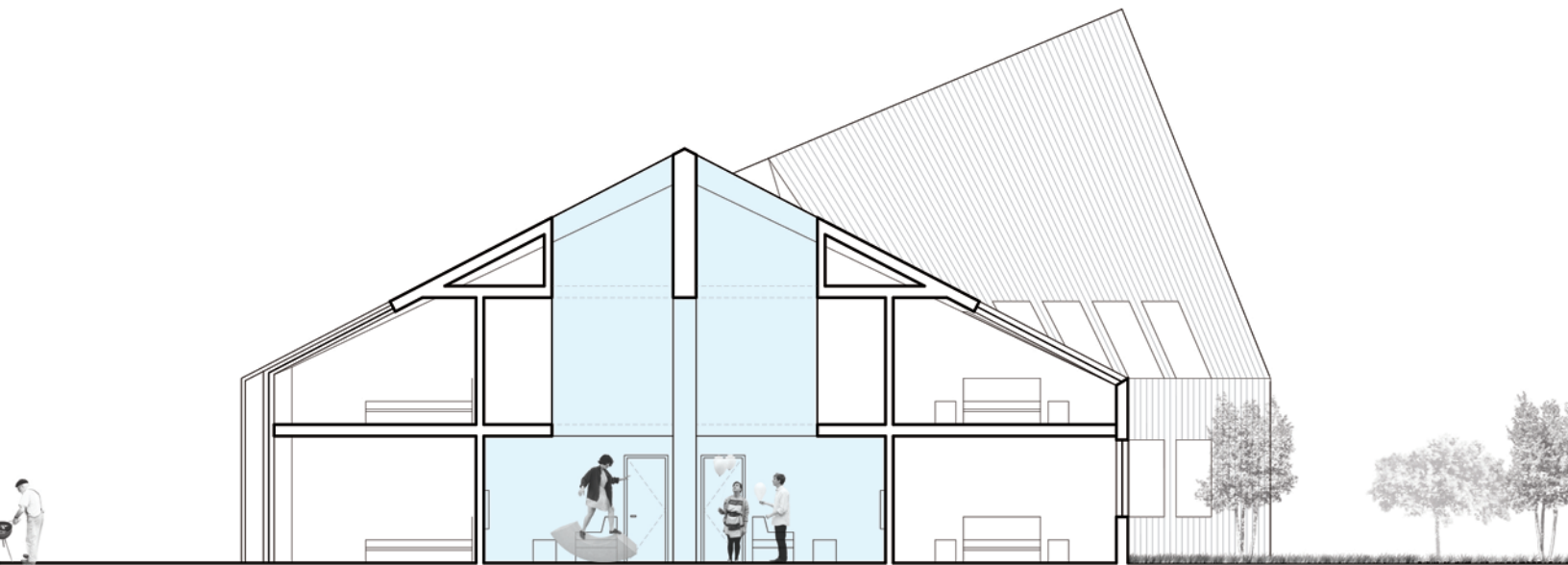
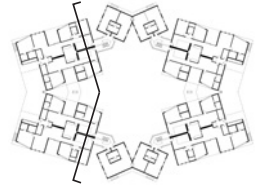

The Communal Spine

—
The communal spine that stitches the units together can be read a threshold of varying porosity. From left: the shared core in the accessory unit / home office allows for an economical “mother-in-law” apartment or a rentable work-space spanning up to four units. The shared greenhouse entry provides entry to all four units, their accessory units and the courtyard and rooftop terrace

they share. The “party wall” in the living room creates the potential for one large room through the simple motion of sliding. The dining room, accessed from both units by a door, is at once between, within and outside of each unit while the peek-a-book cabinets in the kitchen allow for periodic, mediated interactions with one’s neighbors.

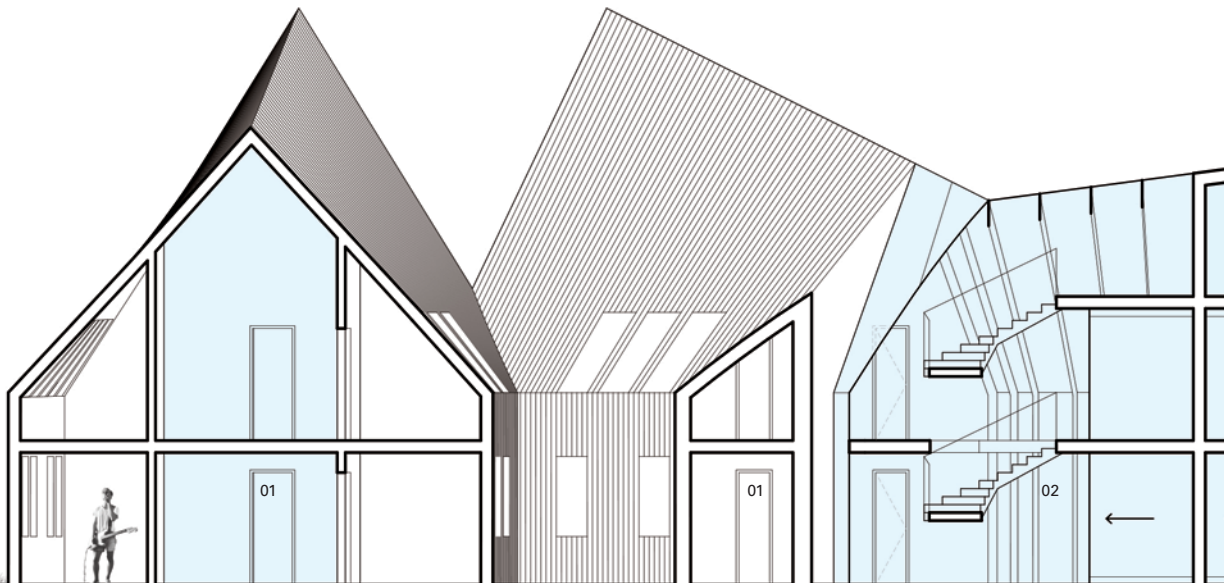

Store House

Long Section at Communal Spine

Scale 1/12" = 1'-0"

- 01 Accessory Unit / Home Office
- 02 Shared Greenhouse Entry
- 03 Shared Living Room
with Party Wall Open
- 04 Shared Fireplace
- 05 Shared Dining Room
- 06 Kitchen with Peek-a-boo Cabinets
- 07 Shared Laundry
- 08 Unit Entrance
- 09 Garage-Sale Storage (Beyond)
- 10 Shared Household Appliance Closet
- 11 Rear Covered Porch (Mezzanine)
- 12 Frosted Lightwell
- 13 Shared Rooftop Porch

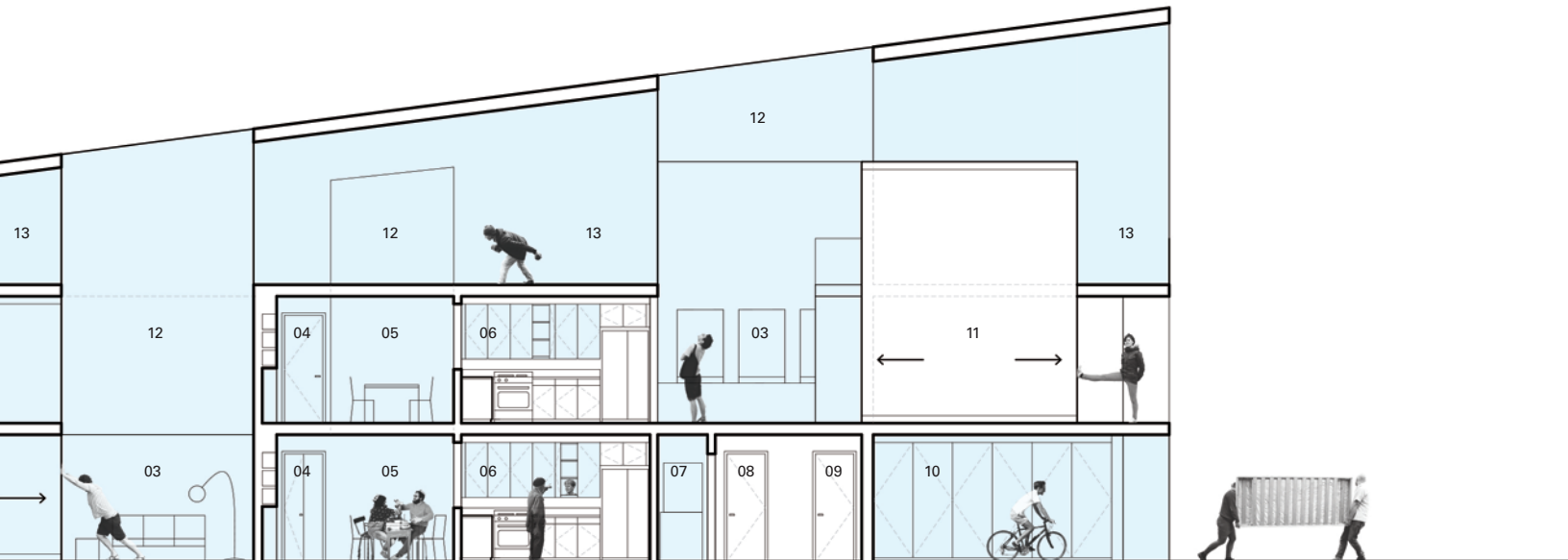
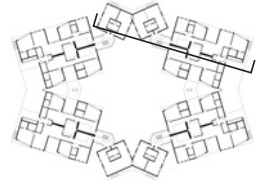

Sectional Model of Communal Spine

Photo by Andy Ryan

110





Sectional Model of Communal Spine

Photo by Andy Ryan

112



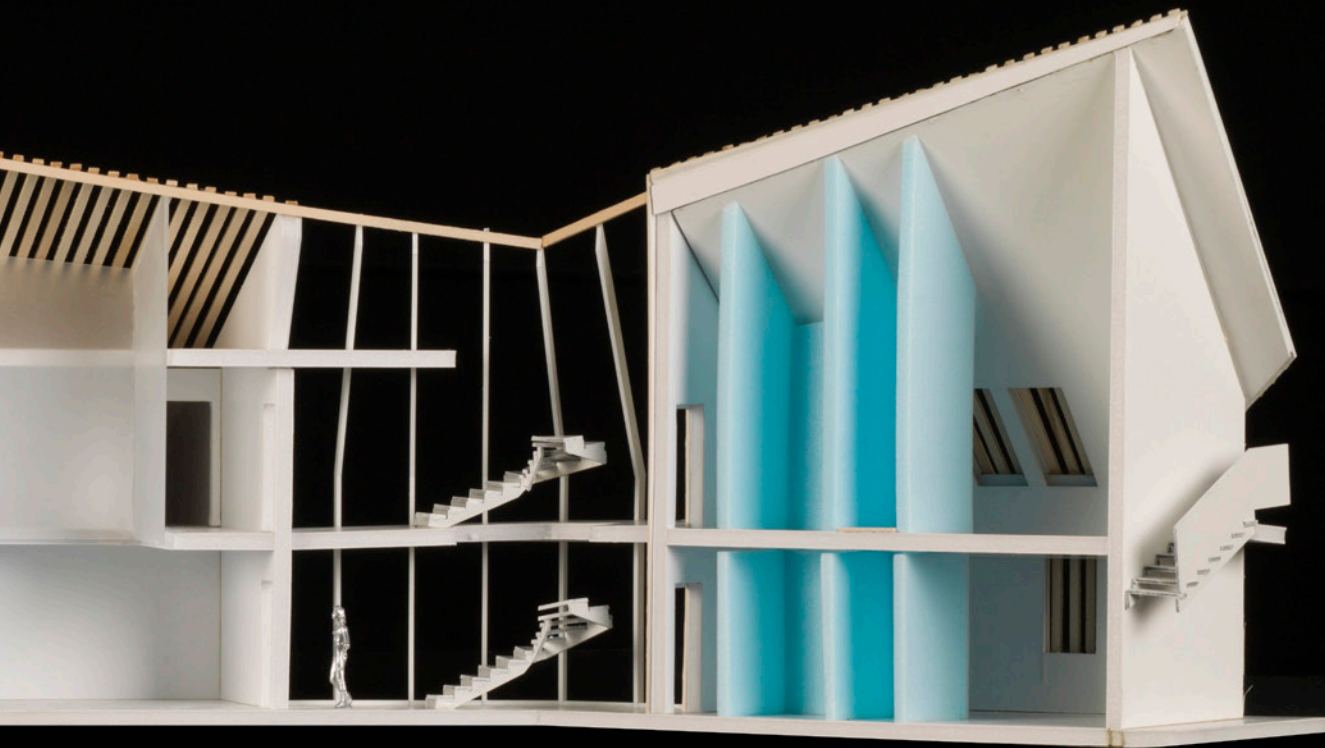

Model of Exterior, View from Street

Photo by Andy Ryan





Model of Exterior,
View from Shared Courtyard
Photo by Andy Ryan





PERFECT STRANGERS

The Suburban Analysis

The American Suburb is the product of individual choices for autonomous living at the scale of the unit, propagated across the scale of the region. Although many houses may exist in close proximity, the collection is merely a sum of its parts: no greater communal spaces are created. It is perhaps overly simplistic to suggest that there is no opportunity for community, but this opportunity comes from individual desire. It is certainly not nurtured by the environment.

The next series of case studies looks at three neighborhoods in different strata of the suburban periphery of Houston. There is a direct correlation between greater distance from the urban core and higher home prices (the inverse of what one sees in most urban areas). Somewhat expectedly, affluence is highly correlated with more trees and a larger quantity of green space per home. In all cases, house placement and landscaping are used to obscure direct views from one residence to another.

Remington Ranch

The Inner Ring Suburb



120

Coordinates

+29° 58' 25.15", -95° 24' 57.09"

City

Houston, TX

Distance from

Downtown Houston

17.2 mi

Average Home Price

\$94,000

Average Home Size

1890 sf

Average Yard Size

2795 sf

Average Space

between Houses

11'-5"

Average Distance

from Street to House

31'-7"

Average Impervious

Surface per Lot

68.6%



Storage

The Suburban Analysis

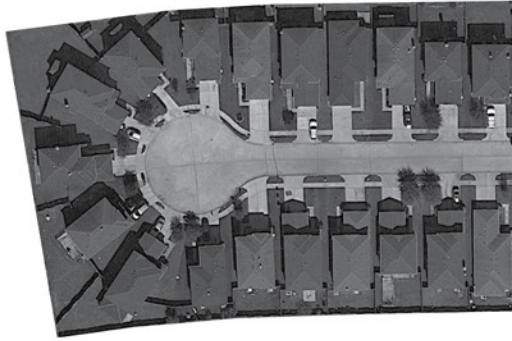

Composite

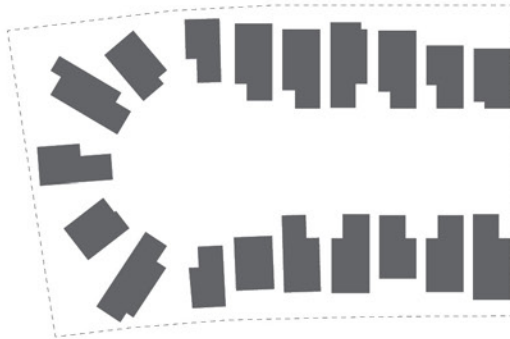

Housing
Single Family Units

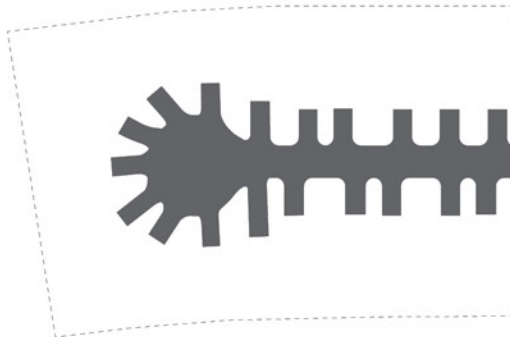

Access
Street to Driveways

Store House

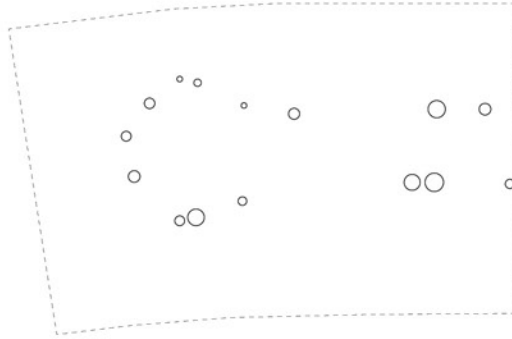

Trees
Screening Device / Amenity

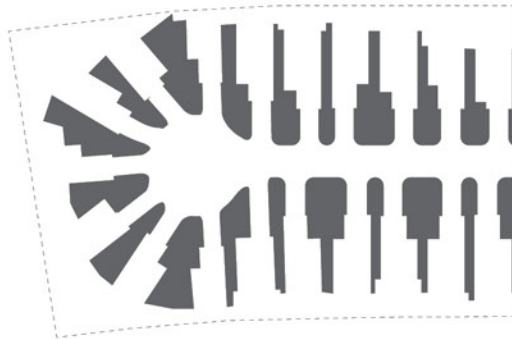

Front Yards
Street Privacy Buffer

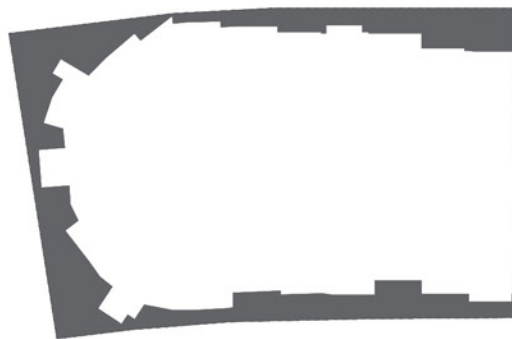

Back Yards
Rear Privacy Buffer (demarcated by a fence)

Memorial Springs

—
The Middle
Ring Suburb



124

Coordinates

+30° 1' 52.47", -95° 34' 34.50"

City

Tomball, TX

Distance from

Downtown Houston

28.6 mi

Average Home Price

\$159,000

Average Home Size

2500 sf

Average Yard Size

3550 sf

Average Space

between Houses

9'-7"

Average Distance from

Street to House

33'-0"

Average Impervious

Surface per Lot

55.0%



The Suburban Analysis

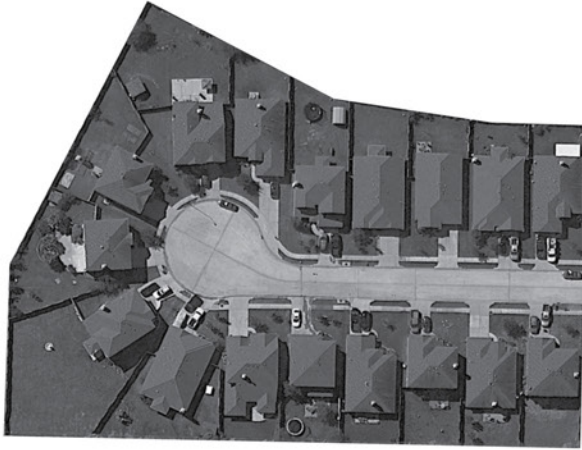

Composite

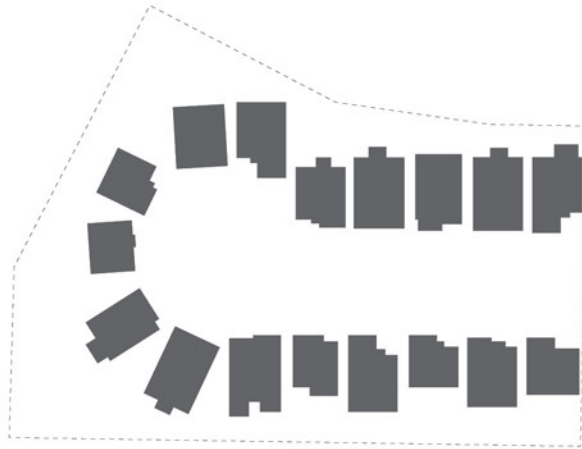

Housing
Single Family Units

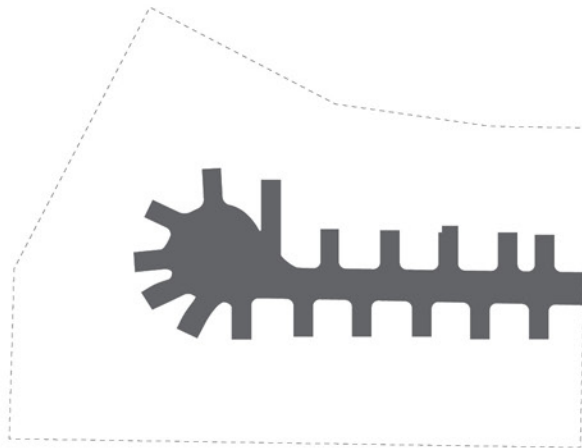

Access
Street to Driveways

Store House

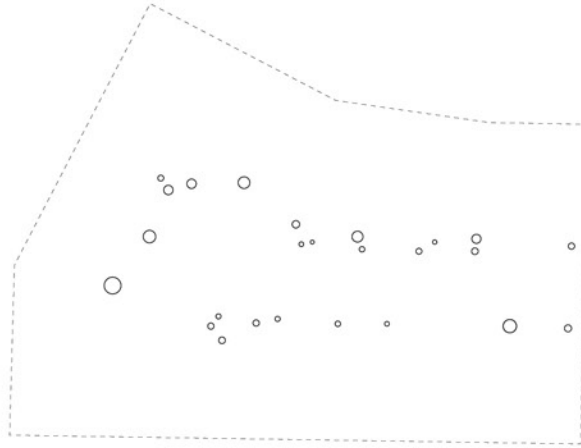

Trees
Screening Device / Amenity

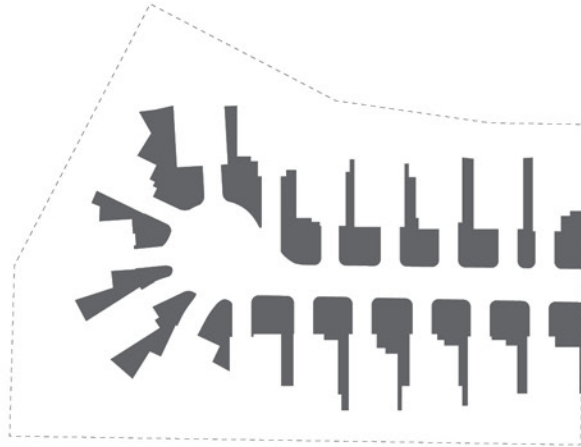

Front Yards
Street Privacy Buffer

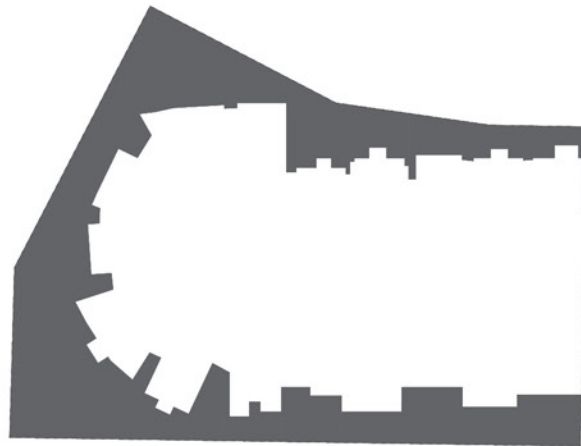

Back Yards
Rear Privacy Buffer (demarcated by a fence)

Inverness Estates

—
The Outer
Ring Suburb



128

Coordinates

+30° 4' 21.31", -95° 33' 54.95"

City

Tomball, TX

Distance from

Downtown Houston

31.0 mi

Average Home Price

\$232,000

Average Home Size

3550 sf

Average Yard Size

5535 sf

Average Space

between Houses

13'-9"

Average Distance

from Street to House

37'-10"

Average Impervious

Surface per Lot

43.6%



Store house

12

The Suburban Analysis



Composite

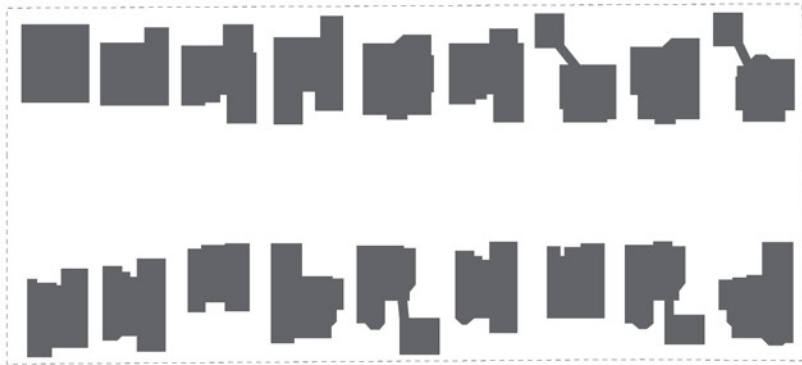

Housing
Single Family Units

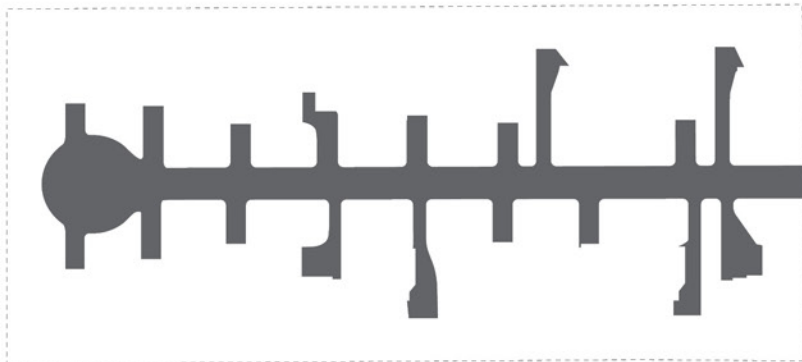

Access
Street to Driveways

Store House

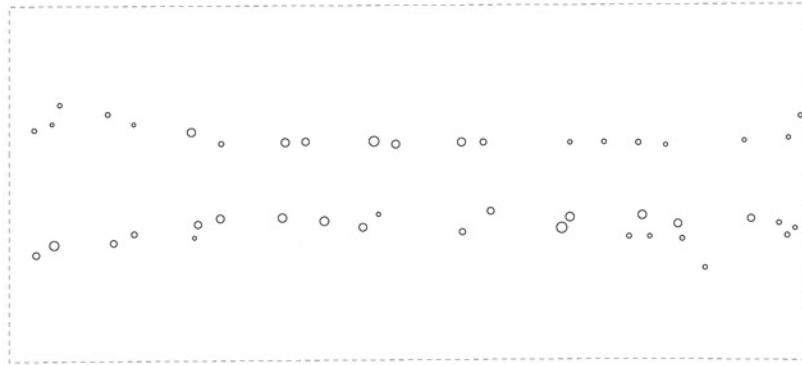

Trees
Screening Device / Amenity



Front Yards
Street Privacy Buffer



Back Yards
Rear Privacy Buffer (demarcated by a fence)

Suburban-Urban Commandments

— The Findings

132

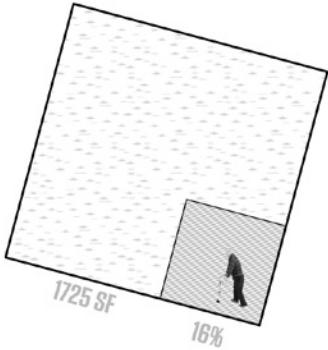

Rule #1

Provide a mixture of soft and hard surfaces around the home. Hard surfaces provide accessibility for the elderly or disabled, a place to drive & park automobiles and a place for gathering, grilling or playing sports.

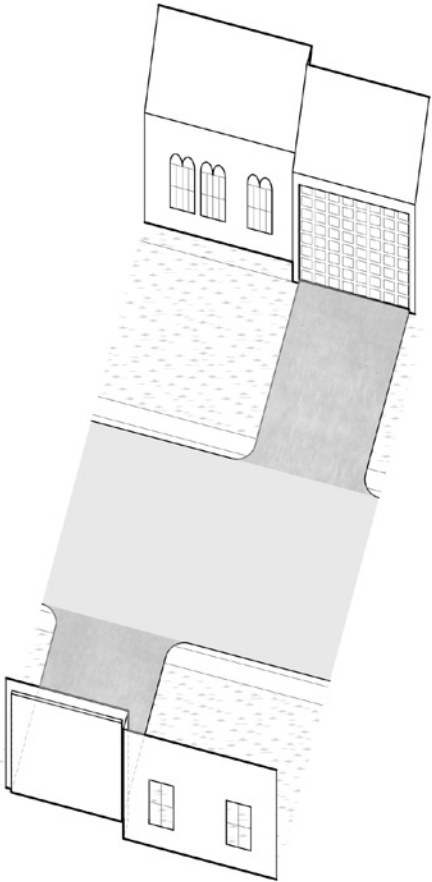

Rule #2

Stagger driveways to avoid direct views between opposing living rooms.

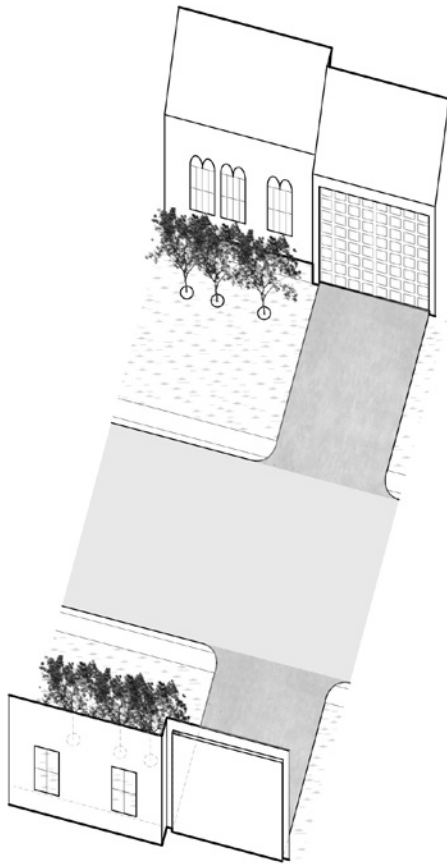

Rule #3

If driveways are aligned, use trees to screen direct views between opposing living room spaces.

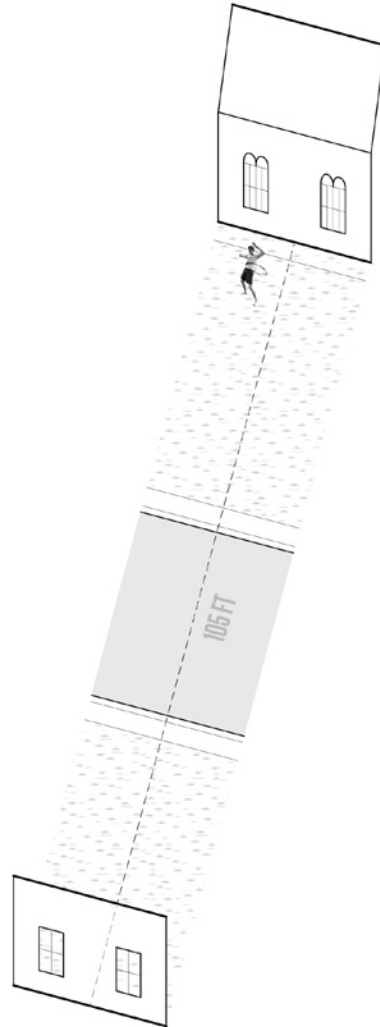

Rule #4

At a distance of 105 feet it is unnecessary to screen views, even when living room windows are aligned.

TOMBALL TEXAS

The Contextual Analysis

Tomball, Texas is located on the periphery of Houston within the San Antonio / Dallas / New Orleans Megaregion. Tomball is a suburb that has been particularly hard hit by the housing crisis (3% of homes are currently in some degree of foreclosure), situated on the outskirts of a city that has become famous for its lax zoning and pathological sprawl, within a state known for everything being “bigger” and in the midst of a rapidly growing megaregion (the tenth largest in the world according to a recent study by Richard Florida). It also has a disproportionately high population of people living alone: a group likely to have a large amount of redundant possessions.

Additionally, Tomball was identified by the Temple Hoyne Buell Center as a possible site for the teams in the Museum of Modern Art’s *Foreclosed* show using a Multi-Criteria Decision Analysis (MCDA) that included:

“Population and population density, the prevalence of detached single-family homes, local vacancy rates, local renting rates, average household size and the percentage of those households that are occupied by families, the percentage of the population that is either elderly or children, median household income and poverty rates, households receiving public assistance and supplemental security income, commute times to work and the means of transportation used for those commutes, the prevalence of new residents (who moved into the area within the last year) and from how far away they moved, race, ethnicity, and educational attainment. The analysis also factors in the mortgage status for owner-occupied homes, meaning how many mortgages homeowners carried and whether they also had home equity loans.” (Bergdoll & Martin, 49-50).

Because none of the *Foreclosed* teams chose to work with this site, this project can be seen as the missing entry to that show. Its addition is significant because it is the only entry located within the nation’s fastest growing population center: the Deep South (Source: *Forbes*).

Historically, in contrast to Houston, Tomball has had a strict zoning code, bordering on exclusionary. The current population reflects these policies: it is richer, older and whiter than the Houston Metro Area. Within the next 15 years Tomball’s population is projected to double from 10,000 to 20,000. Because of this the city has begun to revise its zoning code to allow for greater density. As part of its new strategy the city has created “Planned Development Districts” which are defined as:

“A Planned Development district may be used to permit new or innovative concepts in land utilization not permitted by other zoning districts in this Ordinance and may include, Patio Homes, Zero Lot Line Homes, Single Family Attached and Townhome single family residential dwelling units as part of a master planned development with amenities including open space.” (Tomball Zoning Ordinance, 72-73)

Housing Figures

—
Tomball vs. the US

136

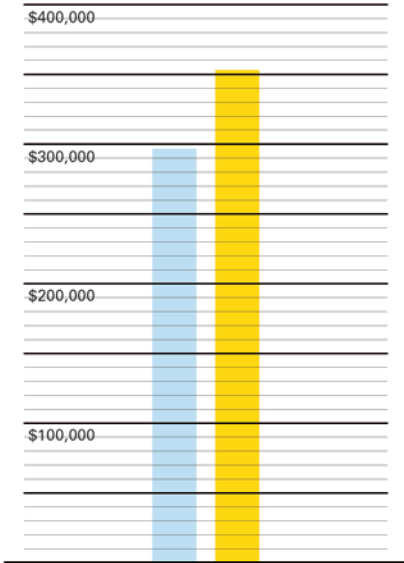

List Price

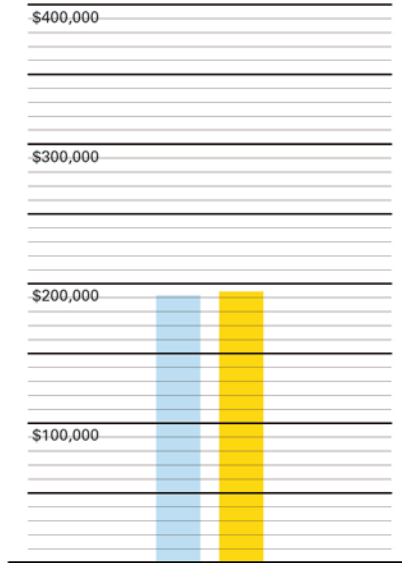

Sales Price

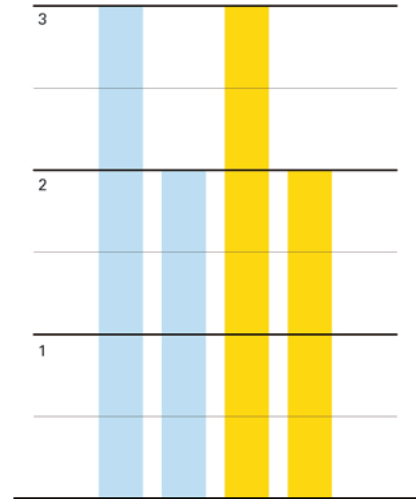

Number of Beds & Baths

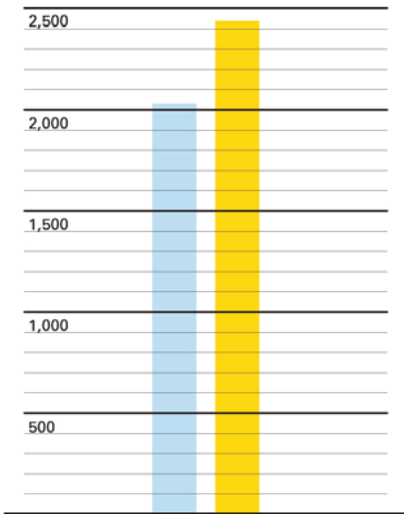

Home Size (Sq Ft)

Home sizes in Tomball are oddly, based on demographic predictors, smaller than the National Average



Price / Sq Ft

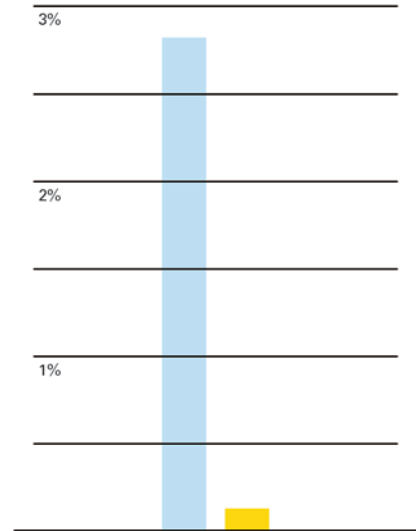

Percent in Foreclosure

Nearly 3% of the homes in Tomball are currently in a state of foreclosure, this is 22 times the national average

Demographics

Tomball vs. Metro Houston

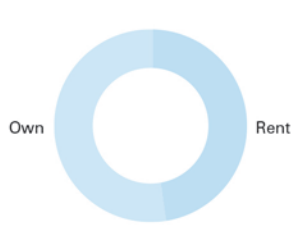

Housing

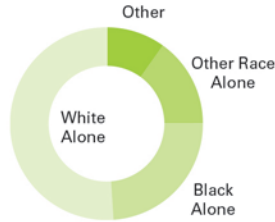
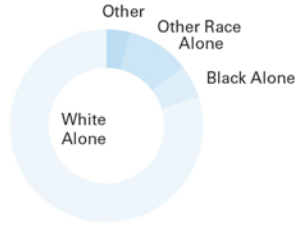

Race

4 out of 5 Tomball residents are white: They are 30% more likely to be white than residents of Houston

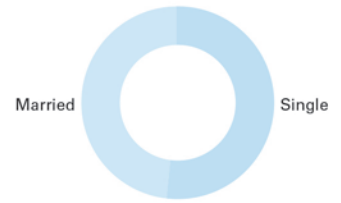

Marital Status

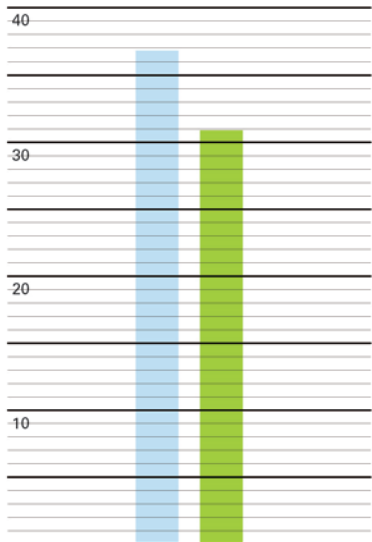

Age

Tomball residents are, on average, six years older than Houstonians



Income /Year

Tomball residents earn 25% more than their Houston counterparts (this amounts to \$4,000 each year)

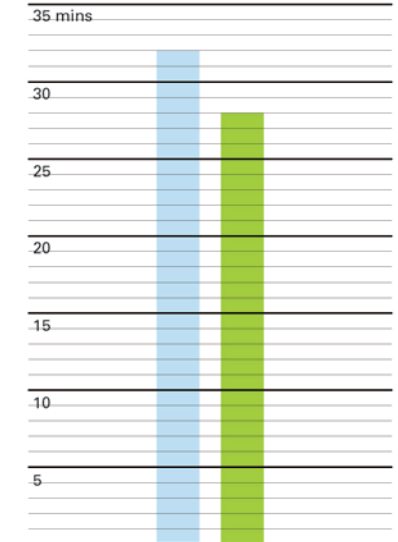

Length of Commute

Population and Location

Tomball and the Site

Texas & Houston

Houston's Growing Boundary

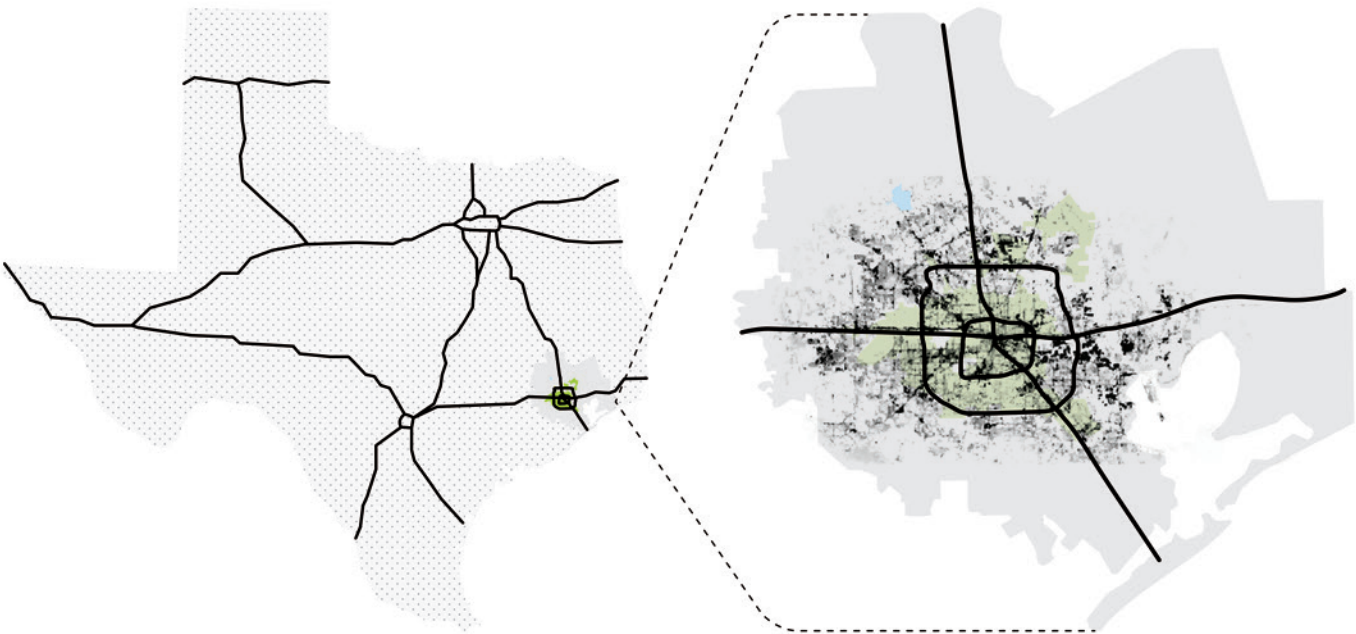

138

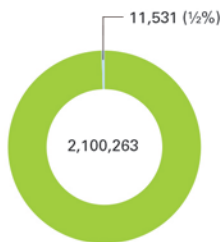

Population

The Tomball population is anticipated to double by 2030

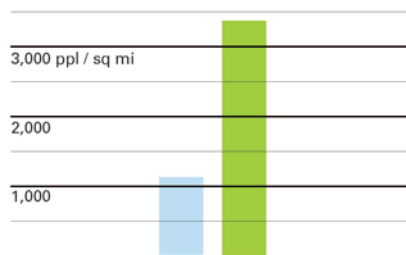

Population Density

Tomball is one-third as dense as Houston, a city known for its sprawling settlement pattern

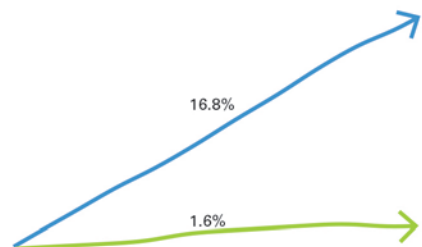

Population Growth

Tomball is growing at over 10 times the rate of Houston (and over 24 times the National Average)

Store House

Houston & Metro Houston

Tomball

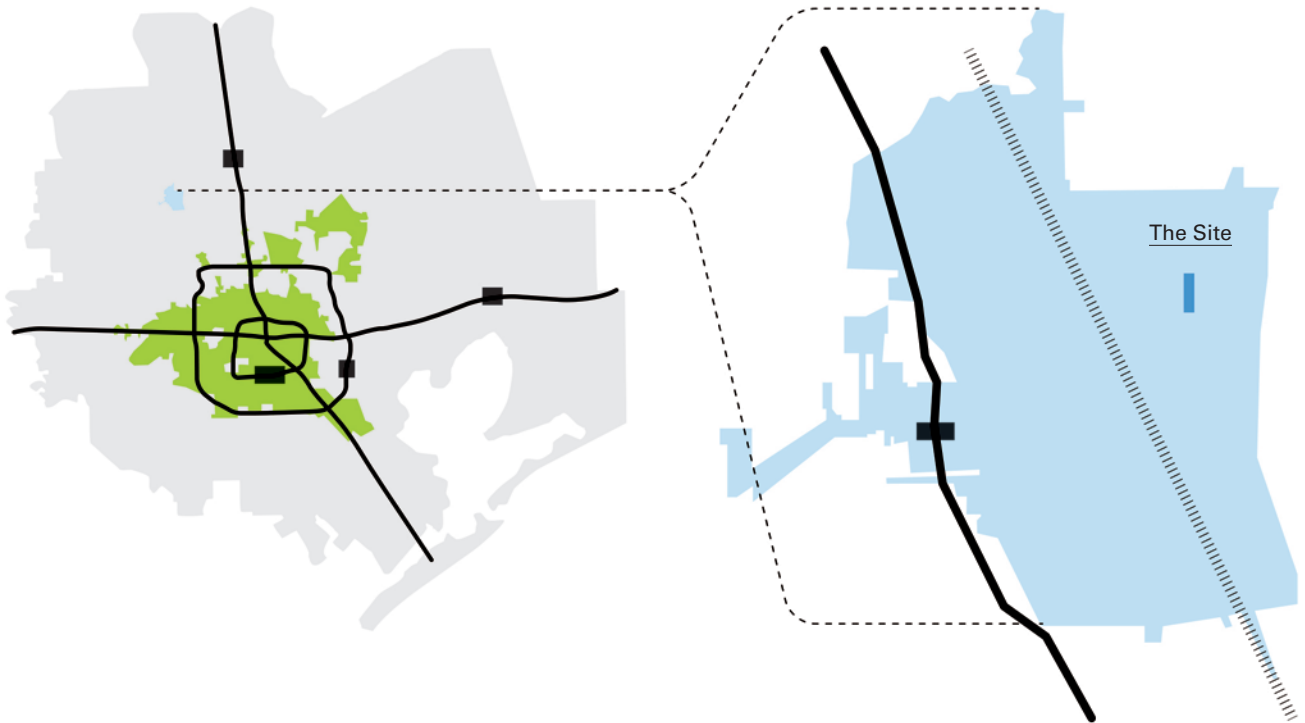

139



Area

The cities of Detroit, Philadelphia, Baltimore and Chicago could fit within the land area of Houston

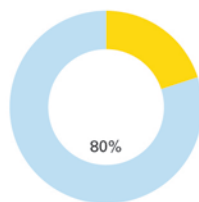

Cost of Living

The overall cost of living in Tomball is 20% more affordable than the National Average

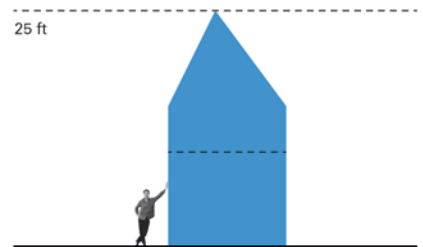

Zoning Height Restriction

The Contextual Analysis

The Site

Existing Conditions

140

Scale 1" = 450'-0"



Store House



The cul-de-sac across the street

141



For Sale

Test Fit #1

Density based on Existing Context



142

Scale 1" = 450'-0"

Site Area
17 acres

of Houses
60

FAR
0.18

Home Size
1,930 sf

Lot Size
9,442 sf

Home Cost
\$123,415

Storage per House
240 sf

Test Fit #2

—
Max Density with New Zoning

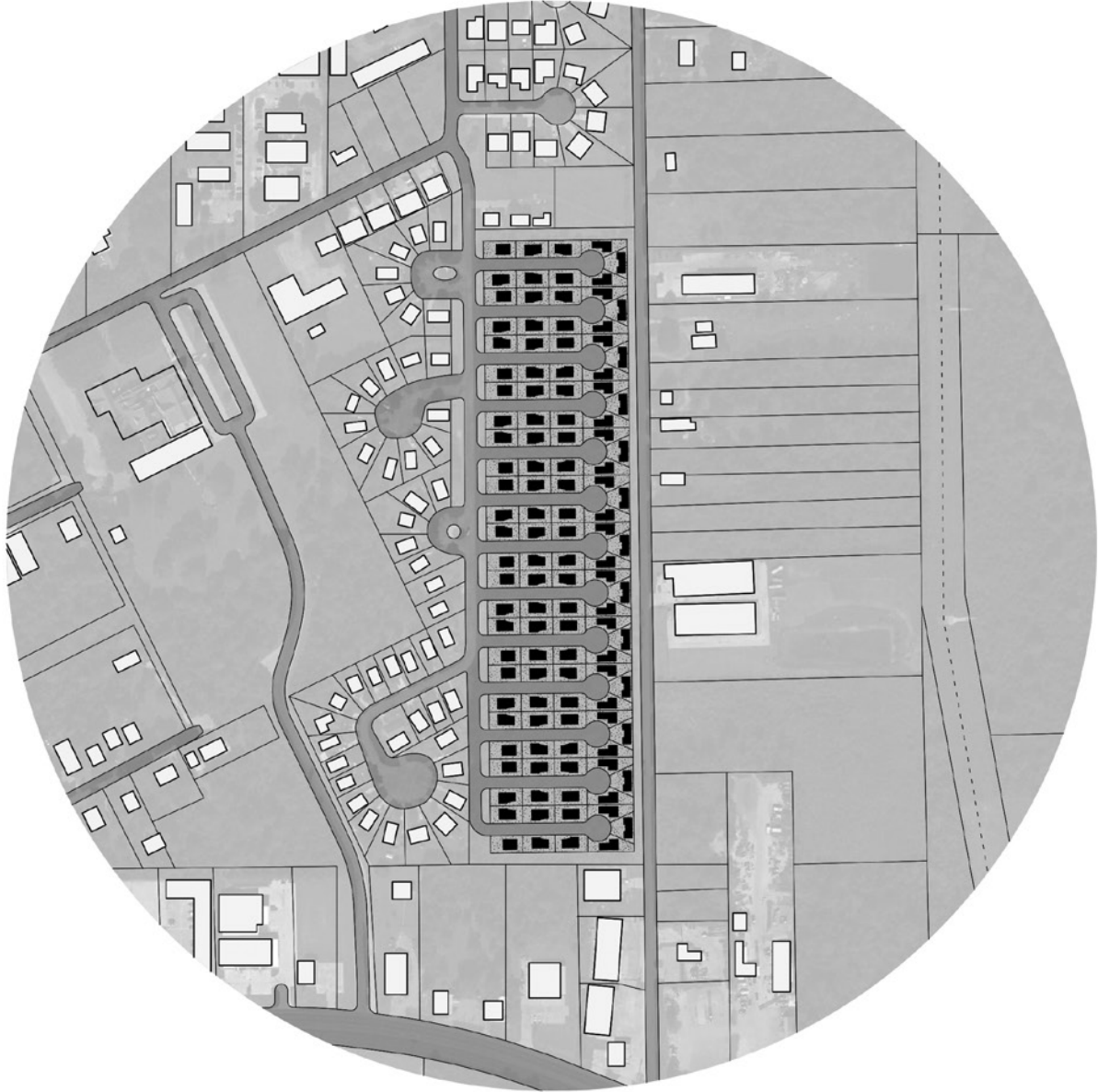

143

Scale 1" = 450'-0"

<u>Site Area</u> 17 acres	<u># of Houses</u> 120	<u>FAR</u> 0.40	<u>Home Size</u> 1,800 sf	<u>Lot Size</u> 3,600 sf	<u>Home Cost</u> \$115,200
			<u>Storage per House</u> 225 sf		

SCALES OF SHARING

The Urban Proposal

The urban proposal leverages a specific repetition of the housing unit to create suitably scaled development clusters and greater opportunities for sharing at the neighborhood scale.

As the sixteen-unit module (described in the “Architectural Proposal” section) moves across the site it creates zones for: consolidated vehicular traffic at its edges; enclosed play spaces between development clusters and; communal pools at the center of every four clusters.

The suburban analysis of views informed the way in which the individual units angle away from one another (1) at the bedrooms, (2) at the juncture where the sides of the rhombus meet one another to form the sixteen-unit housing modules and (3) as those modules bend away from one another at the scale of the site. Around the edges of the site—and in small groves within each enclosed courtyard—the existing trees are preserved to both screen views and create informal zones for play.



The Urban Proposal

Site Plan (left)

Scale 1" = 260'-0"

The numbers on the left indicate unit cluster quantities. The new neighborhood is conceived of as a three-phase project. Each phase is a 64-unit cluster with its own pool. This brings the total number of units in the new neighborhood to a total of 192, over 3.5 times the density of the adjacent context.

Site Plan (right)

Scale 1" = 80'-0"

Each cluster of 64 shares a pool and at least one playground with an adjacent cluster. Vehicular access is consolidated into bundled driveways. Each half of a 16-unit home-cluster shares a driveway on both sides with its neighbors. In this way, carpooling and play dates happen with different neighbors.

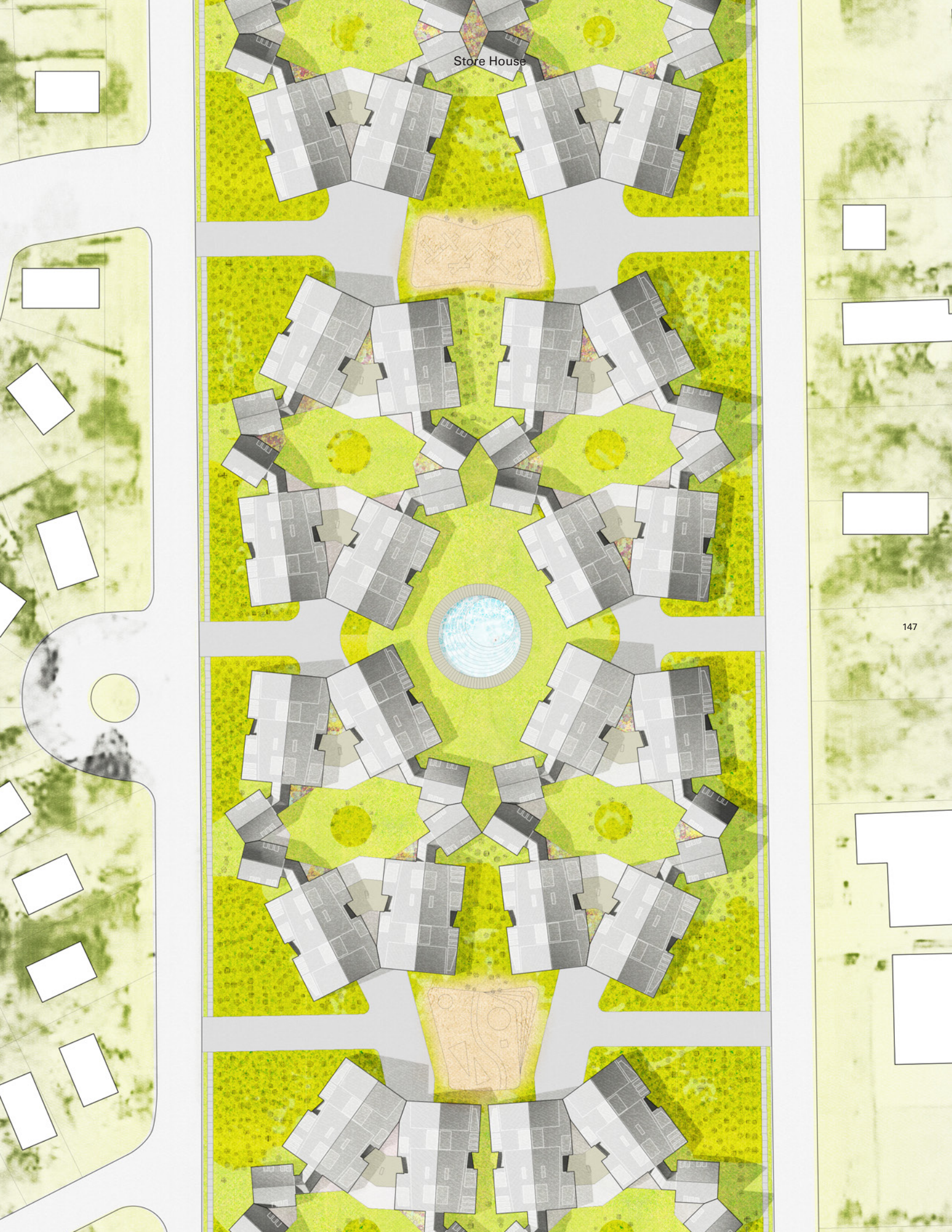

Store House

The Urban Proposal

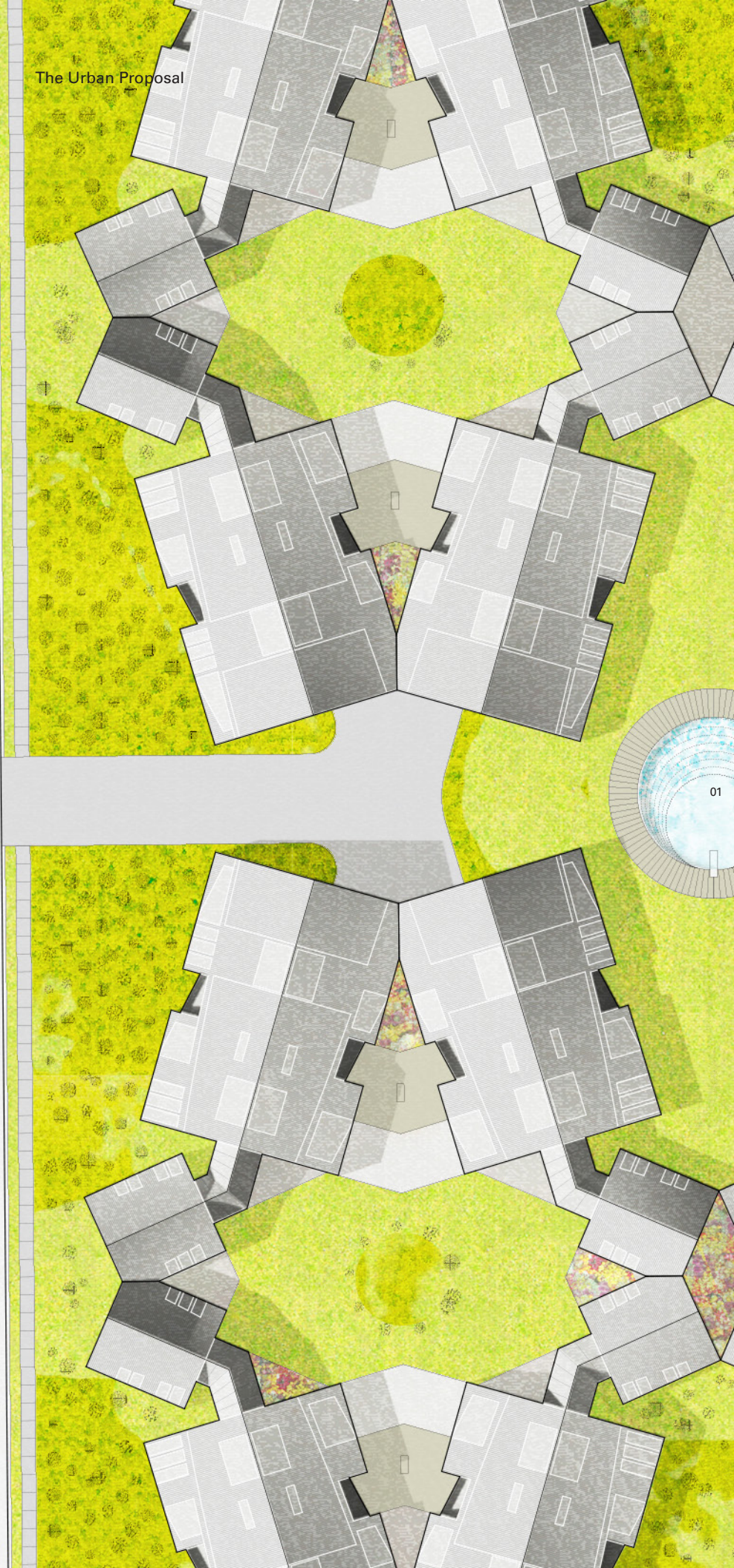
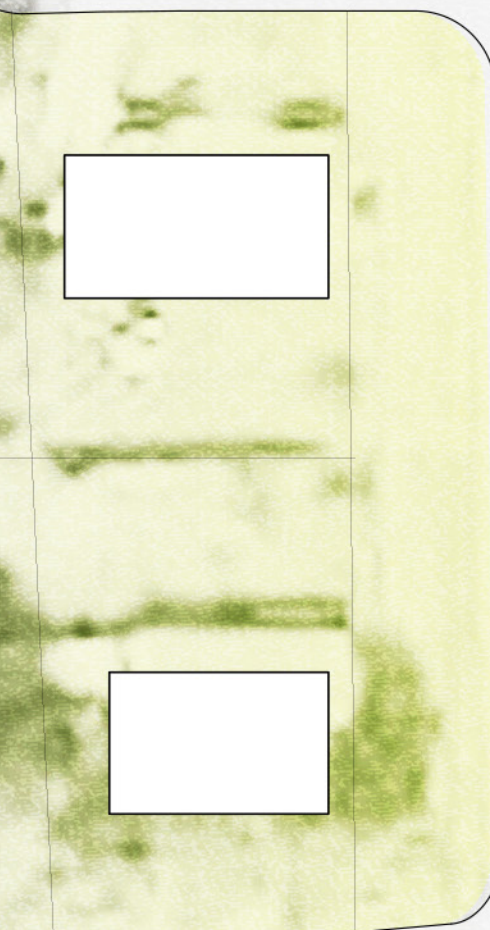



Store House

03

04

02

01

05

05

06

07

Site Plan

Scale 1" = 40'-0"

- 01 Community Pool
- 02 Forest
- 03 Driveway
- 04 Entrance to Shared Garage
(Rear Entrance)
- 05 Entrance to Shared Greenhouse
(Front Entrance)
- 06 Enclosed Courtyard
- 07 Entrance to Accessory
Unit / Home Office

View at Communal Pool





View from West



Store House



EXPERIMENTS AND RESEARCH

The Appendix

American Dreaming

Forty-Six takes on “The American Dream”

What follows is the result of a poll administered anonymously to friends at the start of this process and available to the public via a website throughout.

What comes to mind when you hear the expression, “The American Dream”?

The mental image that springs to mind is the stereotypical suburban house with the perfectly manicured lawn and shrubbery. Owning property in a suburb has deeper connotations of financial independence, stability, comfort, reaching a level of status and being respected in your neighborhood/amongst your peers. The American Dream is typically a goal for the have-nots or the outsiders, and what outsiders want most is to fit-in. The “haves” or the insiders (a lot of times the children of those who have achieved “The American Dream”) often are the ones who aren’t as concerned with fitting in and achieving any level of status.

I think about some fifties Archie comics version of boys in high school building cars in their garages, but I also think about how people invoke it now- less of a dream than an American right to be entrepreneurial and “work your way up.” Most succinctly, I think it means the expectation that if you just do something right, you can make a ton of money out of nothing.

Parents struggling to give their children greater opportunity, hoping to see them climb to achieve more than they could ever dream of.

That hard work and perseverance brings success.

I hear this phrase as “The American Ideal” and it conjures up visions of expansion of democracy, high-minded leaders, and social progress.

Suburban houses, families, kids, front yards, steady jobs, vacations on the beach, steady finances, comfort, ease, community.

It’s something about ownership: like having your own yard and a car. I never really understood what was so great about having your own car and plenty of your own space until I lived in Copenhagen— riding my bike through the chilly rain to my tiny room across town. Sometimes nice but sometimes miserable. I lived in a part of the city that was built before WW2, and I assume that there were plenty of other people living the same way in urban areas before WW2. Afterwards, when you could live in new suburbs (if you could afford it) connected to the older urban areas by speedy highways, I understand the allure of wide, sunny streets and an attached garage. It makes you feel like you have a larger domain and a little bit more control.

Immigrants, rags to riches, entrepreneurship, infinite frontier

People being able to accomplish their personal and professional goals free from governmental restrictions.

To not be restrained by your parents social class and wealth, but to acquire a comfortable or better social class if wanted and a level of at least comfortable wealth. The dream is more a material dream not a spiritual dream. It’s goal is to be comfortable and not struggling—while the way might be a struggle or of discomfort.

I think of hopeful possibilities and opportunities.

Cynical: a) marketing slogan, b) political pabulum, c) excuse for exploitative economic practices. Ideal: a) self-determination, b) economic opportunity through clever hard work, c) stubborn optimism + improvement

Pretty much the post-war stereotype: Going from having little (or even being a recent immigrant) to having a ranch house in the suburbs, a car in the garage, a wife who's barefoot as pregnant in the kitchen, and a job where you will climb a corporate ladder.

I don't believe any of this is relevant any longer. It is isn't relevant socially, economically, nor environmentally yet a large part of the American population continues to go after it, assuming it is indebted to them.

It's a sociological construct and a bit of a stereotype that, nevertheless, has some truth to it. Commonly: rags-to-riches, individualism, a detached single family house with a yard and garage (purchased through a 30-year mortgage), a nuclear family with a mom / dad / 2-3 kids, often a 9-5 job for the man and homemaker for the dad with a good retirement but just as often some kind of other entrepreneurialism type of thing.

Wealth, Suburbia, Single family housing, Backyard, Kids, Schools, Barbeque, Dogs, Cats

A self-made man who has earned himself a large house in the suburbs (with a swimming pool) thanks to his tireless work ethic.

The ability for anyone in this country to become whatever they want to be, regardless of where they came from.

I think of the idea that any member of American society has the fair opportunity for significant advancement of their lot in life based on merit and hard work, regardless of the conditions into which they were born. I think of immigrant families forming businesses and earning their way up the social ladder and progressively gaining acceptance and understanding for their cultures and ways of life. I think of a democratic process that protects the interests of minorities. I also, unfortunately, think of the countless exceptions to this rule in practice that have existed since the creation of the country.

Opportunity to live life to the fullest.

The idea that anyone can rise to greatness through their own hard work.

Starting with very little, working hard your whole life and becoming successful. Which would allow your kids to go to college (albeit overpriced) and have a bright, successful future themselves. Success of course being measured by income, job status and financial freedom.

A house, a yard, kids, and a dog.

An ill-defined, traditional, post-war vision that has guided upward mobility but does not reflect contemporary society. At it's best, it motivates people to strive for upward mobility (think: new immigrant's visions for their children). At its worst, it drives consumerism (housing and credit crash of 2008).

Each person's ability to choose his own path, to want something better for himself and his children and to be free to achieve it with grit and perseverance.

Owning a home with a white picket fence- as much as I hate saying it, but that was the first thing that came to my mind.

House + 2.5 kids + 2 cars + dog (preferably golden retriever).

This vision competes in my mind with the statue of liberty "give me your tired..." etc. American Dream, which I think is more of a dream to be "American" and to have the freedom for any of the above.

Freedom to do what you want and make your own luck.

The ability to pursue whatever career and life path you choose.

Ellis Island

For some reason I think of immigration to the east coast—New York, industrial revolution, Polish and Jewish immi-

grants...the ghettos... It's dark, smoky, damp—but optimistic.

Those that subscribed to the traditional American Dream believed that, regardless of ones background—age, race, ethnicity, gender, etc.—with hard work and determination it was possible to make something of your life. To succeed: be that millionaire entrepreneur or simply a pleasant home and a 1 week vacation for your family. America was a land of opportunity as long as you were willing to work for it.

That version is a little old-fashioned though. The New American Dream is to achieve that same level of success but without the hard work and determination that once defined the American Spirit. This dream is defined by doing as little as possible for the most possible gain. This dream is defined by greedy people doing shady deals to cheat the system, to cheat others, for their own personal gain.

I think of a yard, a front porch, a house in a neighborhood, and a group of kids riding bicycles while someone's dad grills some burgers. I guess I associate summer with the American dream. Actually, now that I give it more thought, I can't think of a winter scenario that fits. That makes me think that my idea about the American dream is much less about architectural space, and much more about a set of circumstances. Almost like a type of game with a specific set of rules.

Starting with few resources and attaining financial stability and supporting a family by middle age.

What many people in America strive to achieve, although for many it is very challenging.

Something that my family encouraged me to do from a young age. I feel that I am on the road to achieving it.

I think that when someone believes in the American Dream that the individual is a goal oriented or driven type of person... That is how they live their lives, in the pursuit of the dream.

Social advancement through hard work. Many associate with home ownership, automobiles, and material goods because these are all status symbols.

When I think of the American Dream, I think of my dad. He immigrated over here from France when he was 28 to earn his MBA at an International Business School in Phoenix, Arizona. Not to say that he came from nothing, but his journey did have humble beginnings. This initial achievement has led to a successful career in the automotive industry, a family, house with a grill and a backyard for a dog (which as it turns out, was his American Dream).

Since this situation is close to me, I always think about that first. However in a broad sense, I think of the American Dream as being an unparalleled opportunity to achieve your greatest aspirations. Being bound by nothing besides your own desire and determination. Seemingly having a sense of control of where you want to direct your life. Whether your passion is a trade, craft, educator, servant, having the opportunity to learn it and pursue it to its' limits (educationally and financially), is what I think embodies the American Dream.

The Oregon Trail, Broadacre City and bad political speeches

White men trying to make it!

Less the dream itself and instead the objects, activities and tastes which build up the paradoxical visual semblance of a collective dream based on an almost anti-collective individuality. Cars with fins, backyard barbecues, linoleum kitchens and so forth. It's a strange thing, I think because after focusing on your question a little bit the definition of the dream itself disappears and can maybe only be held together with the symbols that not only represent it, but actually participate

in constructing its presence.

White picket fence. Owning your own home. Marriage, two kids (one boy and one girl). Success. Having enough money to take a family vacation every year.

An idealized notion of access to success in a country that is willing to forget the dealings of one's ancestors and offer opportunities that more "culturally-indebted" societies are not able to extend. Theoretically.

A little sarcastic voice in my head chimes in when i hear or see this phrase—i have a negative association. It is synonymous with over-consumption, over emphasis on material things and money. I see destruction of the earth/world to allow individuals to prove something... It feels trashy. Listen to "tis of thee" by Ani DiFranco. Watch *Requiem for a Dream*.

Apple pie, red white & blue, and a white picket fence

The desiring of a certain level of material possession.

I use "possession" rather than "possessions" intentionally. "Possession" denotes the state of being controlled by a demon or spirit, of being completely under the influence of an idea or emotion. This is the underlying aspect of "control" or "owning" that the word "possession" also denotes.

Ideology is an example of possession by an idea. In this type of possession the individual becomes part of something outside him or herself that he or she did not create. One becomes, for example, a Democrat or a Republican, a Capitalist or Environmentalist.

"The American Dream" is about possession through material, and even the ideas that influence the character of America regard material things: how to regard oil, trees, land, water .. the apportionment of medicine and technology.

Desire (Tanhā: thirst, craving) operates from the most gross (unsophisticated, unrefined) level of material consciousness. Various hierarchies are

proposed, but in essence, there are two inflections: the thirst for material existence (bhava-tanhā), and the thirst for material extinction (vibhava-tanhā). Desire is a principle cause in the arising of dukkha (unsatisfactoriness, anxiety, fear, etc).

Desire, possession, materiality are all facets of "Dream"—they are all part of the unreal, an illusion, and lead to deluded existence. One definition of "Dream" is "a series of thoughts, images, and sensations occurring in a person's mind during sleep". According to certain Ancient Indian philosophies, "sensations, perceptions, and mental formations" have no "real" independent existence. The cause of suffering is to give these illusions reality.

Another denotation of "Dream" is perceiving something as "wonderful or perfect". This again is not engaging with reality as it is, and inevitably leads to various manifestations of suffering.

It seems to me that much of the contemporary character of America- its current form and historic precedents- has its origin in such dangerous possession by illusion."

The phrase "The American Dream" conjures images of immigrants with babies in tow, abandoning their lives on far away shores for a chance at a better, more rewarding life for themselves and their children here in the United States. It's the hope that through hard work and ingenuity, one can elevate their economic and social status. It's the aspiration to have a good, well paying job, or start a business, own a home, provide for a family and eventually, enjoy life in retirement.

What is your ideal version of
"The American Dream"?

Ideally the American Dream would expand to not just fitting in, but being comfortable (financially, socially, politically) enough to pursue your own unique passions, whatever they may be. So that you're still aiming for a sense of place, it's just not the stereotypical sense of place described above (perfect suburbia).

Um...being rewarded rightly for merit? Being recognized for achievements? I guess I can better answer with the opposite—my American Nightmare is one of "doing everything right," following a clear career path, doing everything I think I'm supposed to do, and then ending up not-so-fulfilled and not-so-successful at age 50. So I guess the American Dream for me is one of doing exactly what I want to do professionally, doing it really well, and being able to support myself and my family in the process.

Doing that. Achieving that. And trying not to hold my snobbery against my folks when I return home.

Also, fighting politically to ensure that class uplift remains a possibility. And that education, the great potential equalizer, only improves in allowing others to strive to overcome whatever obstacles stand in their way.

A life of creative, satisfying work that is also financially rewarding.

The ability to enjoy life to the fullest especially outside of work.

Basically Aaron Sorkin's *The West Wing* (seasons 1, 2, and 3). A country helmed by an inspirational leader whose citizens work together reasonably toward a better world.

Two ways for me to answer that: in general- the American dream should be different for everyone. You could probably say that's a kind of American dream—that everyone gets to follow their own ambitions and dreams free from the biases and prejudices of others. Or better yet, not just free from prejudices of oth-

ers, but with support from others. Not just live and let live, but live, and help others do the same (community).

For me, I'm still figuring it out. Things I aspire to are good relationships with family and friends, good balance between challenging and rewarding work and time for individual pursuits and family/free time. Health and solid finances are both things I aspire to and work to support, but start to fall outside of what I can fully control, so they're not foundational to my American Dream. Community is definitely a big part of it—large & small—country, city, friends, family.

Socioeconomic mobility. Just because you're born in one social or economic bracket doesn't guarantee you will live and die in the same.

Leaving something behind to find something better

Working in a job that is challenging and rewarding, the ability to travel the world, and being able to provide for my family and our future.

Not to transgress in class (middle) but to be comfortable in the material aspects of life: sheltered in a beautiful housing (an architect might have a different standard), access to medical care, retire at 70, be able to support my immediate and larger family and friends if they are in need.

Having the opportunity to study and be successful in my career, family and home life.

Work smart, take risks, make money, pursue happiness

For me it's about the ability to go from being a "no one from nowhere" (even a minority) and being able to pursue any type of life desired. I think the inherent American cultural norms that allow for this is a guaranteed access to education and a heavily embedded layer of political correctness that turns minorities into protected classes and prevents discrimi-

nation of any sort.

I think if I were to take the phrase at face value, without cynicism or baggage, I'd say that my ideal version involves a radical heterogeneity (i.e., the multitude of identities including gender, sexual preference, race and ethnicity, religion and creed, etc. etc. would be allowed to fully be demonstrated and accepted), a progressive will toward quality of life (i.e., everyone would be able to find meaningful work and live healthily and fully), that social structure would allow for a high degree of risk and innovation (i.e., those who want to innovate and develop new technologies, culture, etc. would be given moral, social, and financial support regardless of their success or failure), that there would be a sense of civitas that reflects these ideals, and that our borders would be open to those who want to contribute toward such a world but not that such a world would be forcibly exported at great cost (i.e., we might consider moving toward a balanced isolationism that finds war distasteful).

I feel the original American Dream was more powerful back when there was what could be understood as an "American frontier"...that is, America (if you were abroad), the West, perhaps even the metropolis, etc...someplace that offered a better life than what you had access to. This would be better employment, increased chances of owning your own business and a simply just a better lifestyle- often this failed to exist?

A land of opportunity where what you do matters more than who you are or where you come from. And a land where it's reasonably easy to find almond milk.

I think president Obama embodies it well. Every after-school special said that "one day you could be the president". But until Obama I doubt there were many from the non-white or non-male demographic groups that really believed that. Now I think it's a little more honest, and it's exciting.

My ideal version of the American Dream would first and foremost encom-

pass the goals of social justice, long-term stability and plurality of vision—social and financial mobility should be protected as instruments of this goal rather than ends in and of themselves.

Pursue where my greatest passions can serve the greatest need. (From a Fredrick Bechner quote)

I would like the above to be true. For me this would go along with a government that would actually fairly represent the interests of the common man.

Ideally, I'd say it's changing all the time. But the basics of having the freedom to better yourself financially and intellectually are the base.

A job, an apartment, diverse culture, and a strong community.

A return to a very classic American ideal that if you work hard enough, and with a little luck, you can really achieve a lot. But results are not guaranteed, and may vary—and that's a risk we are willing to take.

And that as a society, we support those who are working hard to achieve that dream, regardless of station or circumstance in life.

I don't know exactly what my "something better" is, but I think it involves: helping others to find their "something better": equality, love, health access, professional purpose, building strong relationships, prioritizing my family's happiness, making enough money to eat organic, travel extensively, and live in a home with lots of natural light—and specifically, having a black lab puppy named "Bear"

2 bedroom 2 bathroom apartment with superb views, outdoor space and low carbon footprint. And world peace!"

Currently, it looks a lot like England. More seriously, though, I don't think I have one. After leaving, I have a much stronger sense of what makes Americans American, but I don't think this has

to do with a dream .. it is more of an attitude. It is hugely stereotypical, but it is a "can do" attitude. A real sense that anything can be achieved and an individual sense that anyone can achieve it. I didn't really notice it until I left and came face to face with a lot of "oh ... I couldn't possibly do that" or "I can't"...

Freedom, flexibility, living the lifestyle you want, in a sustainable way, making money while having fun. Having your hard work and intelligence pay off for you with time to travel, meeting interesting people, and enjoying life.

A country farm with a city apartment. Independently wealthy with a personal assistant. Occasional travel. Responsibly sourced food and heating / cooling resources. Ability to donate to causes.

More appreciation of differences all across the board.

Having it all—living to my fullest in a city whose dynamism, bustle, culture and opportunity support my dreams. The American Dream to me is opportunistic urbanism.

I think I subscribe to the Traditional American Dream. I appreciate the accountability that belongs to it. But I think the Traditional American Dream was of a time when American Exceptionalism instilled an American Pride and Global Envy. I'd argue that the American Dream belongs to a much larger Global Dream, and people everywhere are struggling to make that a reality, not just Americans. So, to type it out completely:

My American Ideal Dream (here after referred to as MAID) borrows the belief that Hardwork and Determination will result in equal opportunity for financial success.

MAID also extends to the right to be governed well. That if the people express concern and outrage over issues, then those issues will be appropriately addressed.

And finally, MAID extends the definition of success, to open the cultur-

Store House

al perception of what it means to succeed, and allow people to dream more broad, live more courageously, and risk more frequently.

In summation, MAID rests on the belief that, if we are truly a nation undivided, our American Dreams should not come at the expense of others' MAID, but each MAID should lift up each and every other MAID.

I like this question. I guess I would say my ideal version of the American dream is less specific than what I wrote first. It is more abstract like just "contentment." But that doesn't seem very American, does it? Maybe the better way to describe it is to say my ideal version of the American Dream is to have a home. Not necessarily a house with a garage, etc, but just a place where I become spatially, and culturally rooted. A PLACE I can really call home. Maybe it is architecturally spatial after all...

Owning a house in a decent school district; having two kids; and not having to work more than 45 hours a week to be able to support all this.

My ideal American dream is financial independence. The ability to own your own home, provide for your family, educated, provide for your retirement, and splurge on vacations and other fun activities once in awhile.

To be prosperous. Whether that means financially, family, health, etc... Or maybe being successful.

Work hard to provide for my family and create a solid foundation for my children and future generations.

Short Answer: Being able to create/build something out of nothing.

Longer Answer: Over the past several years, I think that my experience in retail design and exposure to new things has shaped my world perspective and burgeoning endorsement of small businesses.

I admire small businesses because they represent someone who chose

something they truly believed in, and pursued it into reality. Finding your skill or passion, and able to carve something out for yourself. (Cue soaring eagle with transparent stars and stripes in background)

Free healthcare, free education and higher taxes....so...socialism?

Solving problems, creating deep experiences and spaces for people to enjoy while also making money of course.

I suppose it's simple, but I would like to believe in a world that's open enough to afford me the opportunities to do what I think I would be good at, and diverse enough that there may be other people who would share these interests. So for me it's not really about individual freedom so much as a cultural diversity that's capable of allowing individual dreams to find a meaningful subculture. I prefer subcultures over a dream of unconstrained individuality I think, at least in idea if not in practice. So maybe my ideal American dream would be to have a few more flexible symbols of the dream to articulate this, as in, not just cars with fins and backyard barbecues but maybe arm wrestling competitions and bird watching and facial tattoos as well.

Equality. An America where every person has equal rights and is treated with dignity and respect. An education system that is high quality and accessible to all. Health care that is free and available to anyone who needs it.

One that challenges the nationalist notion of a concept that, as Americans, we are entitled to "protect." There is an undertone that since the dream is "American," that we are entitled to be the "winners" and "successful," to the exclusion of those not matriculated.

The ideal version would therefore refer to the romanticized American "experiment" as a template for making available opportunities for all people, and considering the whole ecosystem of a global society.

Hmmm...People from many backgrounds uniting and leading by example - using our resources and freedoms to develop sustainable technology and to show that people with different beliefs can peacefully coexist.

Freedom and justice for all. And ice cream.

Part of my answer to the above question really answers this one:

Another denotation of "Dream" is perceiving something as "wonderful or perfect" (what you call in this question an "ideal"). This again is not engaging with reality as it is, and inevitably leads to various manifestations of suffering.

My ideal version of "The American Dream" blends the traditional definition discussed above, with a social and environmental responsibility element. I would like to achieve some of the traditional "American Dream" goals of good/secure income, a healthy and comfortable existence, with the hope that this can be achieved while contributing meaningfully to the quality of life of those around me.

Suburban Stasis

—
But the Cars *Have* Changed



162

1947
Levittown

What is remarkable about these two photos is how little the suburban home, and the neighborhood it belongs to, has changed in the 65 years of its existence. It has grown exponentially, but remained formally consistent. When one considers the technological & societal shifts that have occurred over that same period—the Civil Rights Movement, the

birth of the computer, the emergence of the internet, to name but a few—it highlights, quite potently, the resilience of the “American Dream.”

Even in the face of global financial catastrophe the suburb flourishes. Housing starts are up almost 30 percent from last year.



2011
South Carolina

Toll Brothers CEO Douglas C. Yearley Jr. speculates that “pent-up demand, rising home prices, low interest rates, and improving consumer confidence motivated buyers to return to the housing market in Fiscal Year 2012.”

“Prices are up, the Federal Reserve is deliberately trying to bring down mortgage rates to spur housing activity, and

consumers are more and more optimistic about the economy and willing to spend. *Toll Brothers* is just a smaller part of a larger story of a resurgent housing market in 2012.”

—Matthew Zeitlin, *The Daily Beast*

The Dynamic Domestic Interior

—
From Thick & Prolific
to Thin & Sparse

164

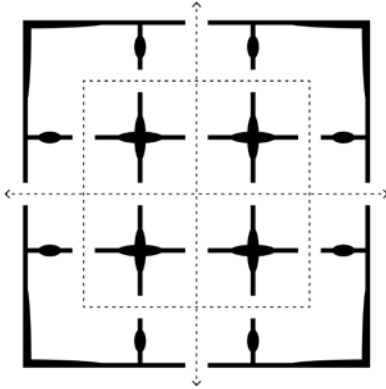

Multi-Directional Circulation

"Little attempt was made to arrange the parts of the building into independently functioning sets or to distinguish between 'serving' and 'served.' But this was not the absence of principle...[within the Villa Madama] the connectivity was the same throughout. This did not happen by accident. It, too, was a principle."

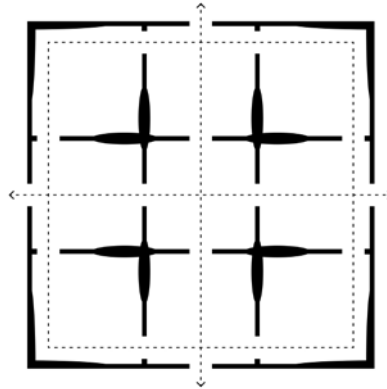

Peripheral Circulation (Enfilade)

"The magnanimous gesture of putting doors between some of the rooms at Coleshill [was done] to obtain the visual effect of a receding perspective...Accordingly, the integration of household space was now for the sake of beauty, its separation was for convenience."

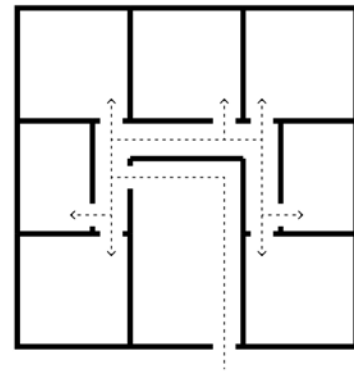

Confined Circulation

"A compartmentalized building had to be organized by the movement through it, because movement was the one remaining thing that could give it any coherence...With connected rooms, the situation had been quite different. There, movement through architectural space was by filtration rather than canalization."

Part of what has been lost in this spatial evolution is the articulation of the wall. The wall has gone from something that could be figured as part of an aesthetic / functional project to something purely economical and generally anemic as a result. This project seeks to dialogue with the wall more willfully. How can we be economical with walls to allow for spatial & programmatic extravagance? How can we leverage conventional cavity construction to our advantage?

“Modern housing appear[s] to transcend our own culture... This is easily enough explained, since everything ordinary seems at once neutral and indispensable, but it is a delusion, a delusion with consequences too, as it hides the power that the customary arrangement of domestic space exerts over our lives, and at the same time conceals the fact that this organization has an origin and a purpose.” —Robin Evans

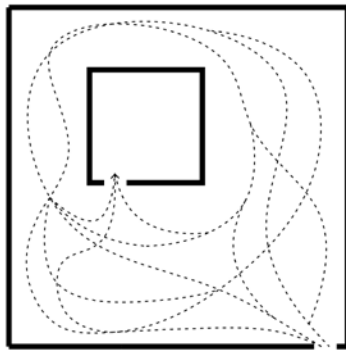

Nodal Circulation

Robin Evans ends his seminal article, “Figures, Doors, and Passages” with the corridor. Interestingly he does not discuss the open plan, which was central to Modernism. The example above shows a “Glass House” style open plan with a central node, usually a service core, that creates differentiated zones within the larger space. In this model circulation is liberated, one could argue far more so than in the “Multi-Directional Circulation” model that Evans seems to favor.

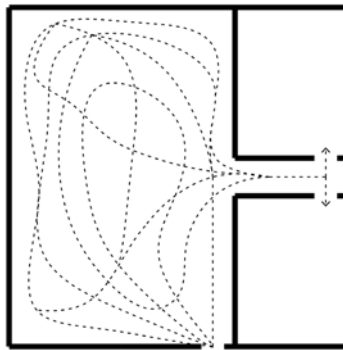

“Open Plan” Circulation

The current trend in suburban home design is “Open Concept” living. Essentially, this alters the DNA of the “Nodal Circulation” above by expanding the quantity of enclosed program and pushing it to one side of the plan. This creates a zone for privacy and a zone for more flexible programs—living room, dining room and kitchen—to aggregate in to one larger “great room” that can accommodate many uses.

Source: Evans, Robin. “Figures, Doors and Passages.” *Translations from Drawing to Building and Other Essays*. Cambridge, MA: MIT, 1997. 54-91. Print.

The Evolution of Storage

—
My How You've Grown



c.1600
Bureau

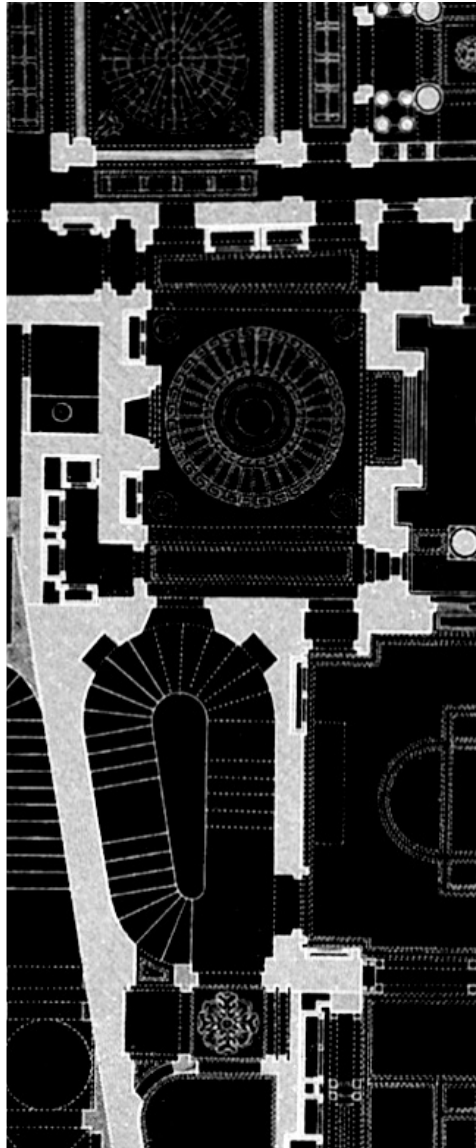

c.1700
Storage Poche



1945
Built-In

166

We own more objects than we ever have: how do we store things today and how have we stored them historically? The images below show a progression from furniture to wall to room-based storage, meaning that over time as our thirst for

storage has grown the person responsible for providing it has shifted from furniture-maker to architect to organizational-consultant.

The next several spreads investigate this shift—keeping in mind that all of



1958
Storage Unit



c.1975
Walk-In Closet



2014
Collective Poche

these modalities are still in operation—in hopes of uncovering a way for architecture to reclaim this territory and improve upon the past.

From Left: Engraving from Ferrante Imperato's *Dell'Historia Naturale*; Sir John Soane's Home; George Nelson's Built-In for *Time Magazine*; a self-storage unit; an ad for *California Closets*; *Rock-climbing in the Closet* by the author. Image Credits: Rights retained by authors

Storage Poche

—

Sir John Soane's House



168

Sir John Soane did not have a closet, rather he figured the poche of the walls in his home at Lincoln's Inn Fields to create niches and alcoves for display (he also affixed things directly to the walls or to shelving along the walls).

- | | | |
|---------------------|------------------|---------------------------|
| 01 Porch | 08 Dressing Room | 15 Picture Room |
| 02 Outer Hall | 09 Monument Ct | 16 Picture Room Recess |
| 03 Inner Hall | 10 South Passage | 17 Monk's Tomb |
| 04 Dining Room | 11 Anteroom | 18 Monk's Yard |
| 05 Library | 12 Dome | 19 Staircase to the Crypt |
| 06 Breakfast Parlor | 13 Colonnade | |
| 07 Study | 14 Corridor | |

View of the Dome looking east at the bust of Sir John Soane, statue of *Apollo Belvedere* in the foreground.



Storage Poche

—
Recesses & Niches

Dining Room and Library



Dressing Room and Study

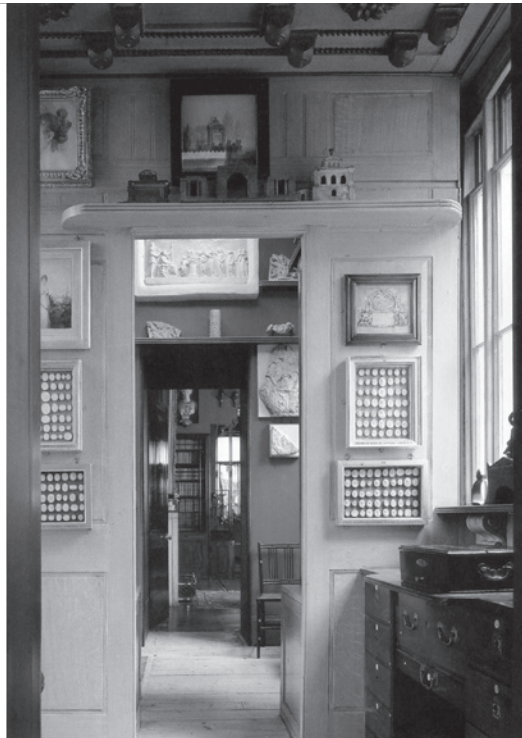

Breakfast Parlor

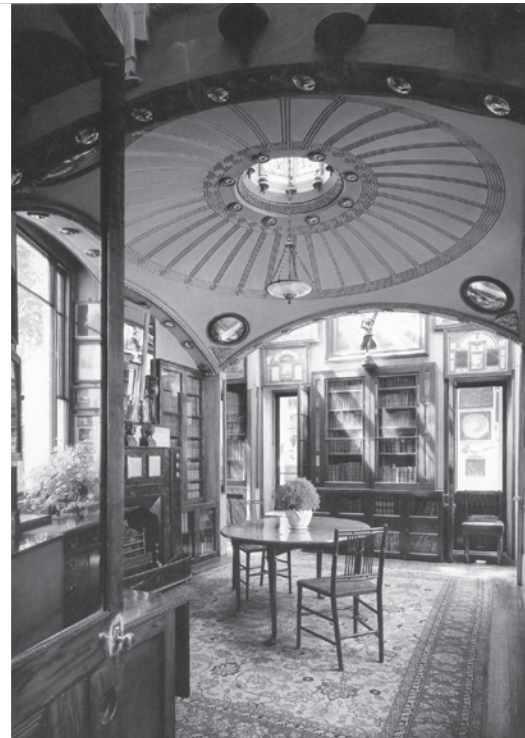

First Floor

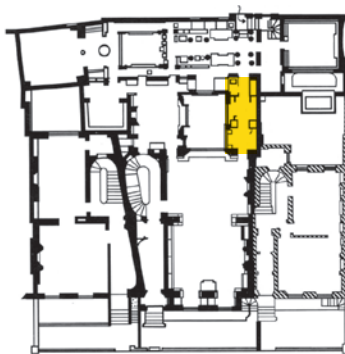

First Floor

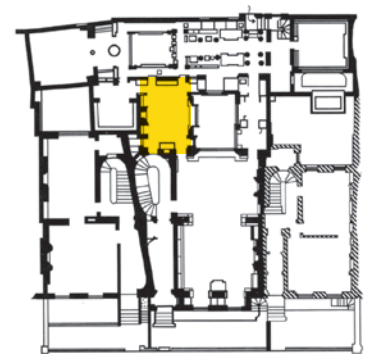

First Floor

Store House

Colonnade

Crypt

Picture Room Recess

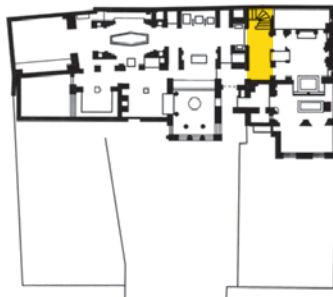

First Floor

Ground Level

First Floor

Storage Poche

—
Shelving

Model Room



Upper Drawing Office

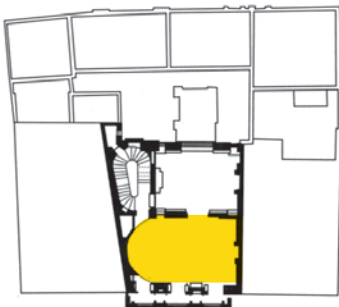

Second Floor



Second Floor

Storage Poche

Refiguring



1796
Soane purchases No. 12
Lincoln's Inn Fields.



1810
Soane renovates No. 12 Lincoln's Inn
Fields and purchases No. 13, renovat-
ing the stables into the Dome (alternat-
ely called "The Museum").

173



1822
Soane continues to renovate No. 12
& No. 13 Lincoln's Inn Fields refiguring
the stair; adding the Monument Court-
yard, Dressing Area, Study, New Break-
fast Parlor, the start of the Colonnade;
and renovating the Dining Room.



1837
Soane incorporates No. 14 Lincoln's
Inn Fields, expanding the colonnade
& crypt and adding the Picture Room
& Picture Room Recess.

Storage Poche

—
Aberrant Poche

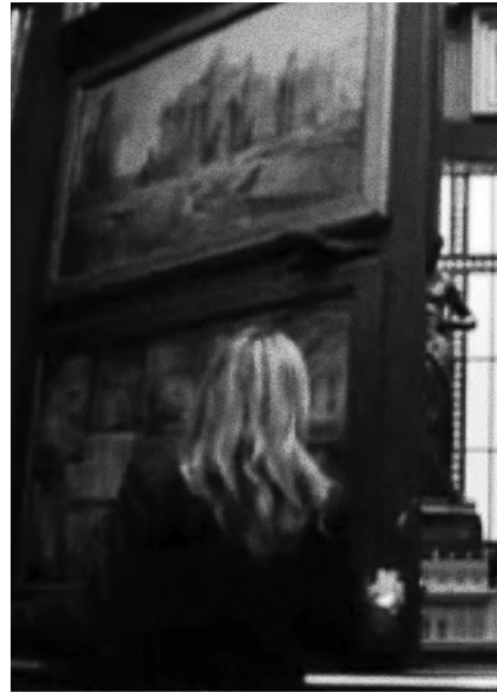

Store House

A system of hinged panels allows for the display of over one-hundred paintings and several models in a room of approximately 135 square feet. His collection includes three paintings by Giovanni Antonio Canal (Canaletto), several by J. M. W. Turner, and two by William Hogarth.

In these images, museum docents demonstrate the double-layer of panels along the southern wall of the Picture Room (in the final frame you can glimpse the Picture Room Recess beyond with the *Nymph* by Sir Richard Westmacott). The northern and western walls each have a single layer of the same hinged panels.

Source: *Sir John Soane's Museum - London UK. Monumental Adventure*, 15 Jan. 2008. Web. 17 Apr. 2013.



Self Storage

—
America's Sweetheart

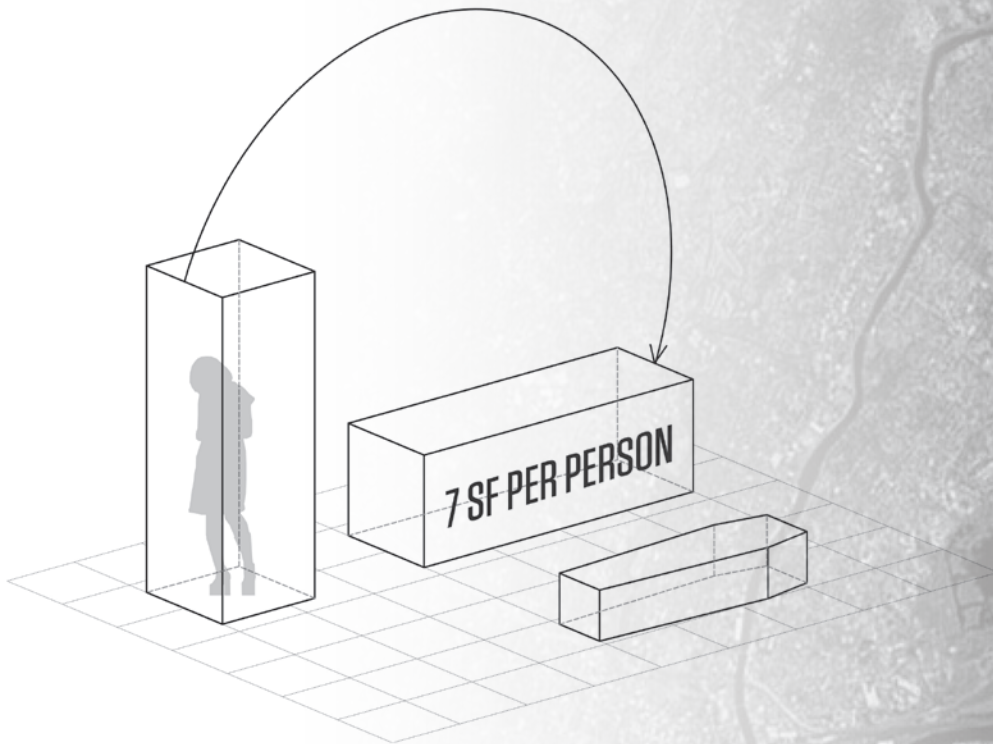

176

From its birth in the late fifties, self-storage has grown to 7.25 square feet per US resident (that's three times the size of a coffin).

That adds up to 3.25 billion square feet, or approximately three times the size of Manhattan.

Store House

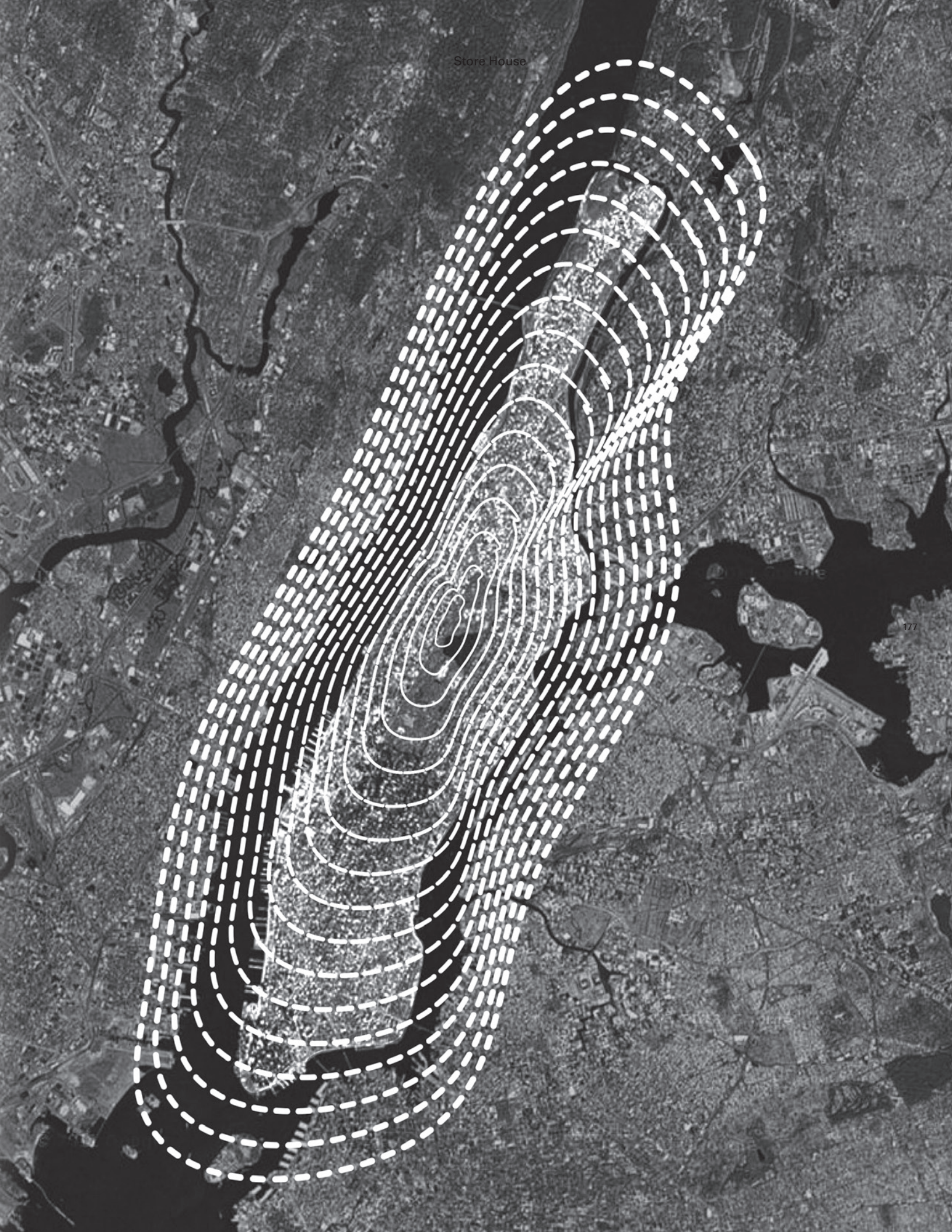

Walk-In Closets

— Living in the Closet

In a survey conducted by *USA Today* 60% of people said that they would be willing to pay \$1,350 more for a house with a walk-in closet. In the same survey, 44% of respondents between the ages of 35 and 54 viewed a walk-in closet as “very important.”

California Closets, the nation’s leading walk-in closet outfitter, was founded in 1978. By 2005, it had a revenue of \$241 million, a 16 percent increase from the previous year. The price of the company’s products ranges from \$400 to \$30,000.

In 2004 *The New York Times* wrote that *California Closets* was one of the initial companies to “offer sleek storage for those doing without an architect.”



Collective Poche

A Possible Future

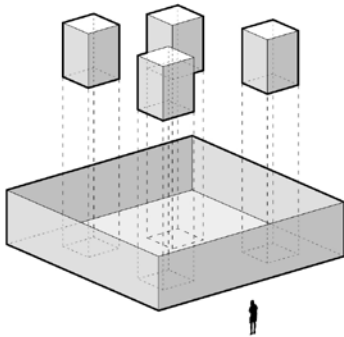

Typical Storage Distribution

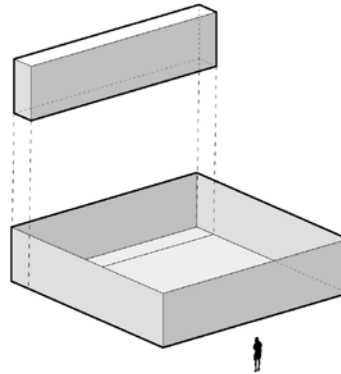

Revised Storage Distribution

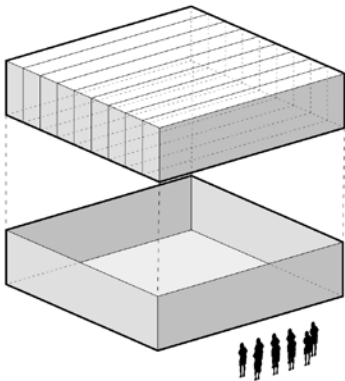

Collective Storage

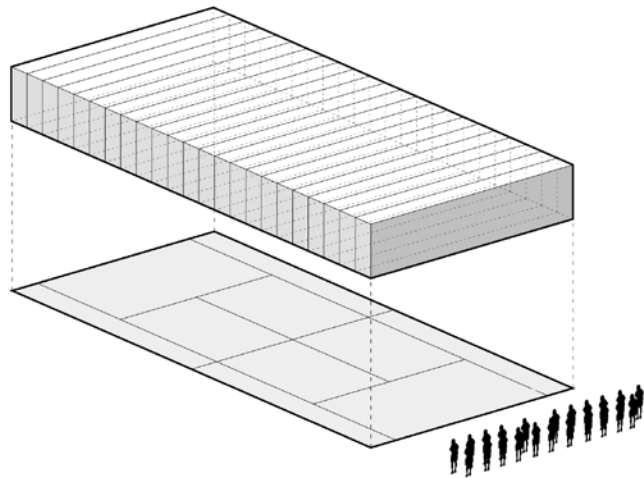

Collective Storage / Tennis Court

180

In the US there is 1100 square feet of housing per person. Over 133 square feet of that is storage. This means that for every nine square feet of housing there is one square feet of storage. If rather than atomizing storage around the space of the house we could aggregate it,

not only within a single unit but across multiple units, one can begin to imagine an overall reduction in redundant possessions through collective ownership. This decrease could allow for the creation of spatial amenities beyond storage.

Right: *Rock Climbing in the Closet*, a speculative collage.

















The Commercial Storage Landscape

Racks on Racks on Racks

Dimensional Standardization

FedEx's standard boxes can be seen as a contemporary building block for dimensioning storage space: if one accounts for their sizes, space can be occupied more efficiently. A dimensional interval of 6 inches accommodates the largest quantity of boxes for better spatial packing.

 12" x 9" x 6"	 8" x 8" x 8"
 12" x 12" x 18"	 11" x 11" x 11"
 13" x 9" x 11"	 14" x 14" x 14"
 17" x 17" x 7"	 16" x 16" x 16"
 18" x 12" x 3"	 20" x 20" x 20"
 20" x 20" x 12"	 24" x 24" x 24"
 15" x 15" x 48"	 27" x 17" x 12"



Store House

Nearly all commercial storage solutions can be boiled down to the two variations below (with infinite permutations): a series of adjustable shelves / racks that are either fixed (upper) or mobile (lower). While the lower version offers a higher capacity, the upper version is more cost-effective, sturdy, dependable and safe.

Southwest Solutions
Fixed Shelving

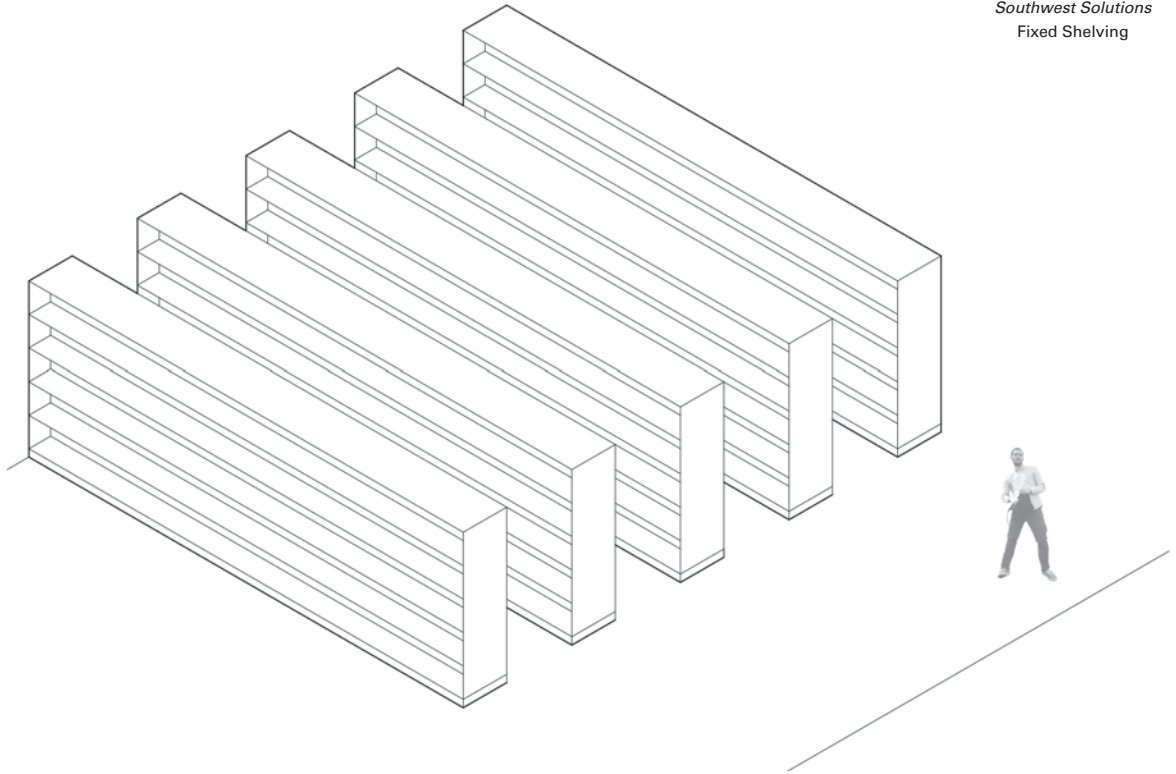

183

Southwest Solutions
Mobile Shelving

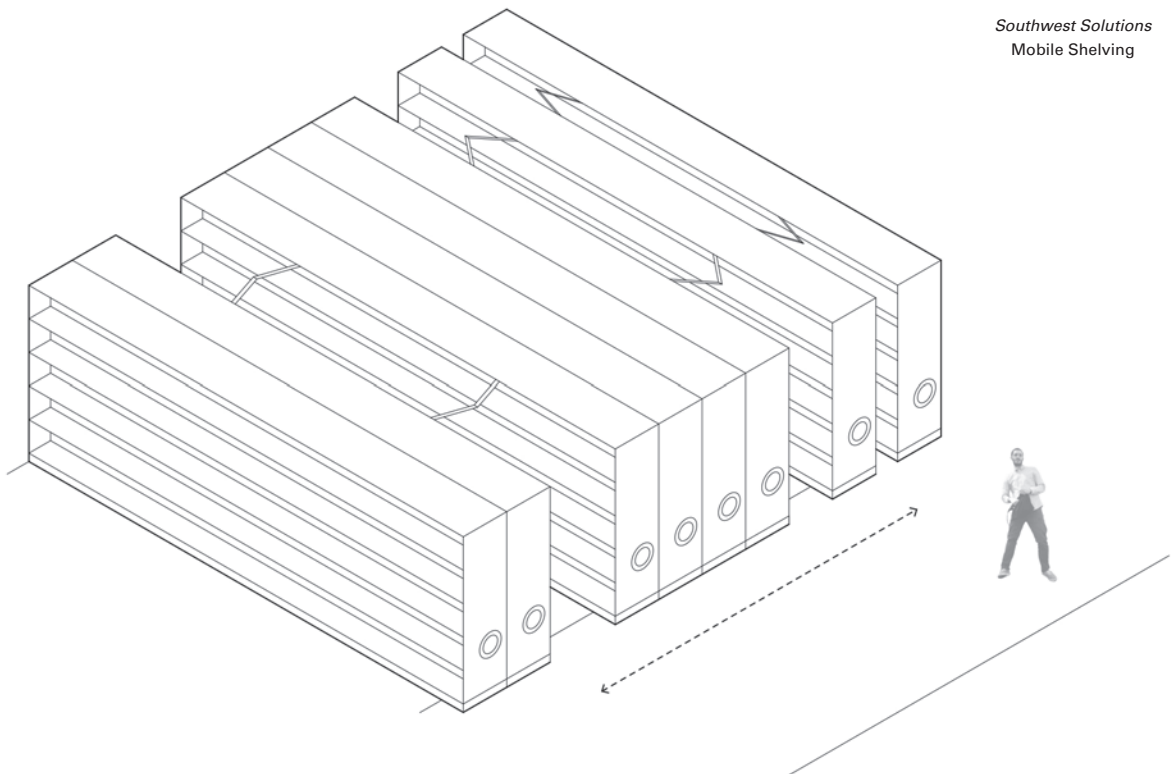

The Appendix

This page illustrates a storage / retrieval solution for order fulfillment facilities. One can see how it takes the simple logic of a racked version of the systems on the left, angles the shelves for gravity feeding and provides space on both sides for access.

Unarco Rack's Carton Flow Warehouse Storage Solution

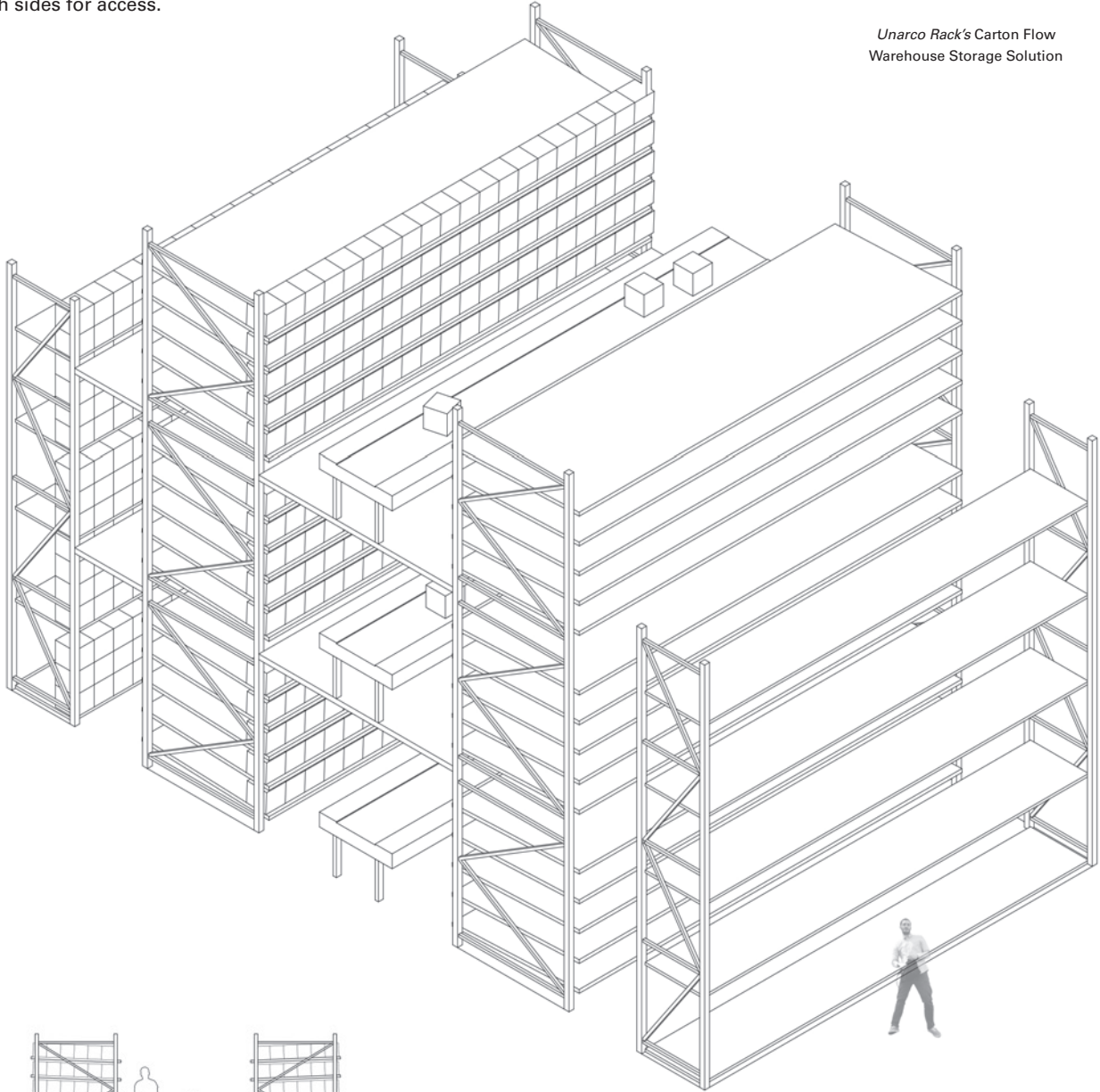

184

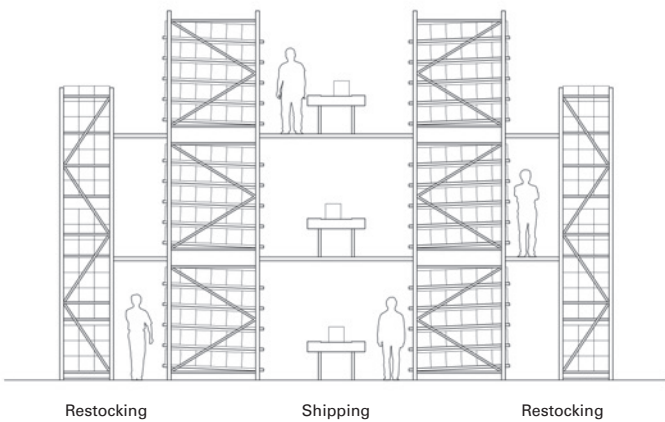

One of Amazon's warehouses. Image Credit: *The Atlantic*



Toll Brothers

Selling the Dream

Company Profile

Toll Brothers—“America’s Luxury Home Builder”—officially began in 1986 (although its predecessors were in operation as far back as 1967). It operates in 19 states: Arizona, California, Colorado, Connecticut, Delaware, Florida, Illinois, Maryland, Massachusetts, Michigan, Minnesota, Nevada, New Jersey, New York, North Carolina, Pennsylvania, Texas, Virginia & Washington. *Toll Brothers* is a publicly owned company whose stock is listed on the NYSE as TOL.

Specialty

Single-Family Detached and Attached Residences

Revenue

US \$1.88 billion (2012)

US \$1.5 billion (2011)

Operating Income

US \$63 million (2012)

US \$48 million (2011)

Net Income

US \$490 million (2010)

US \$49 million (2011)

Employees

2,117 (2010)

Quotes from their Promotional Video

“We’ve been in business for over 40 years. We offer the best value, the best quality, the best designs, and the best attention to detail of anybody in the home business.” (2)

“We’re proud of the fact that we don’t just build homes we build communities.” (3)

“With *Toll Brothers* you’ll enjoy the personal interaction and attention to detail of a small, custom, family builder.” (4)

“Whether you’re looking for customized estate homes in majestic settings, low-maintenance town homes...stylish resort retreats, or spectacular country club living on a golf course, *Toll Brothers* can capture your vision to build your one-of-a kind dream home.” (5 & 6)

“[On our website] every enhancement you select is seamlessly added to create a personalized home that is uniquely yours.” (7)

“In every *Toll Brothers* community the focus is on living a fulfilling lifestyle and providing excellent value, catering to both families & active adults.” (10)

“Just as much thought goes into our neighborhoods as in to our homes, and it all begins with community planning that is committed to being environmentally friendly. *Toll Brothers* is dedicated to maintaining our award-winning conservation efforts and continues to set the standard by building high-performance, energy-saving homes.” (12)

“We do everything possible to preserve existing landscapes so that your neighborhood blends beautifully into its natural setting.” (13)

“We offer a wide range of financing options to maximize your investment.” (14)

“*Toll Brothers* has become an icon of American elegance...so start living the good life today!” (18)

The *Toll Brothers* Promotional Video. Source: tollbrothers.com/about/toll_brothers_video



Robert I. Toll
Executive Chairman, Toll Brothers



Stone House

2



Toll Brothers
America's Luxury Home Builder®

3



4



5



6



7



Toll Brothers
America's Luxury Home Builder
Design Studio



10



18

12



13



- FINANCIAL SOUNDNESS
- QUALITY OF PRODUCTS
- QUALITY OF SERVICES
- LONG TERM INVESTMENT

14



NHQ
National Housing
Quality Award

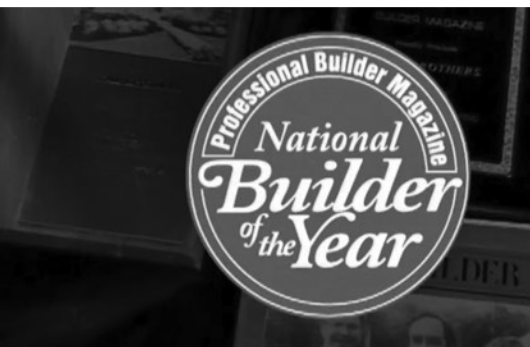

Professional Builder Magazine
National
Builder
of the Year



18

Neighborhood Baggage

Shedding Pounds through Sharing

This drawing looks at the spatial and financial implications of ten items within one category of consumables—outdoor items—at the neighborhood scale: grill, bicycle, lawnmower, edger, ladder, rake, trash can, shovel, watering can, hose.

Here the dimensions and prices of the top-selling *Amazon* items are used to determine the spatial and financial savings of a new ownership model.

The upper scenario looks at the typical neighborhood of 60 households. The lower scenario uses the same number of households, but uses the 20/80 rule—we use 20% of our possessions 80% of the time—to show a scenario in which four households share each item (with the exception of trash cans and bikes at one per household).

This sharing amounts to a neighborhood savings of \$108,822.20 or \$1,813.70 per family.

It also frees up the spatial equivalent of four shipping containers at 8'-0" x 8'-6" x 40'-0" per container.

Store House

Typical
Neighborhood

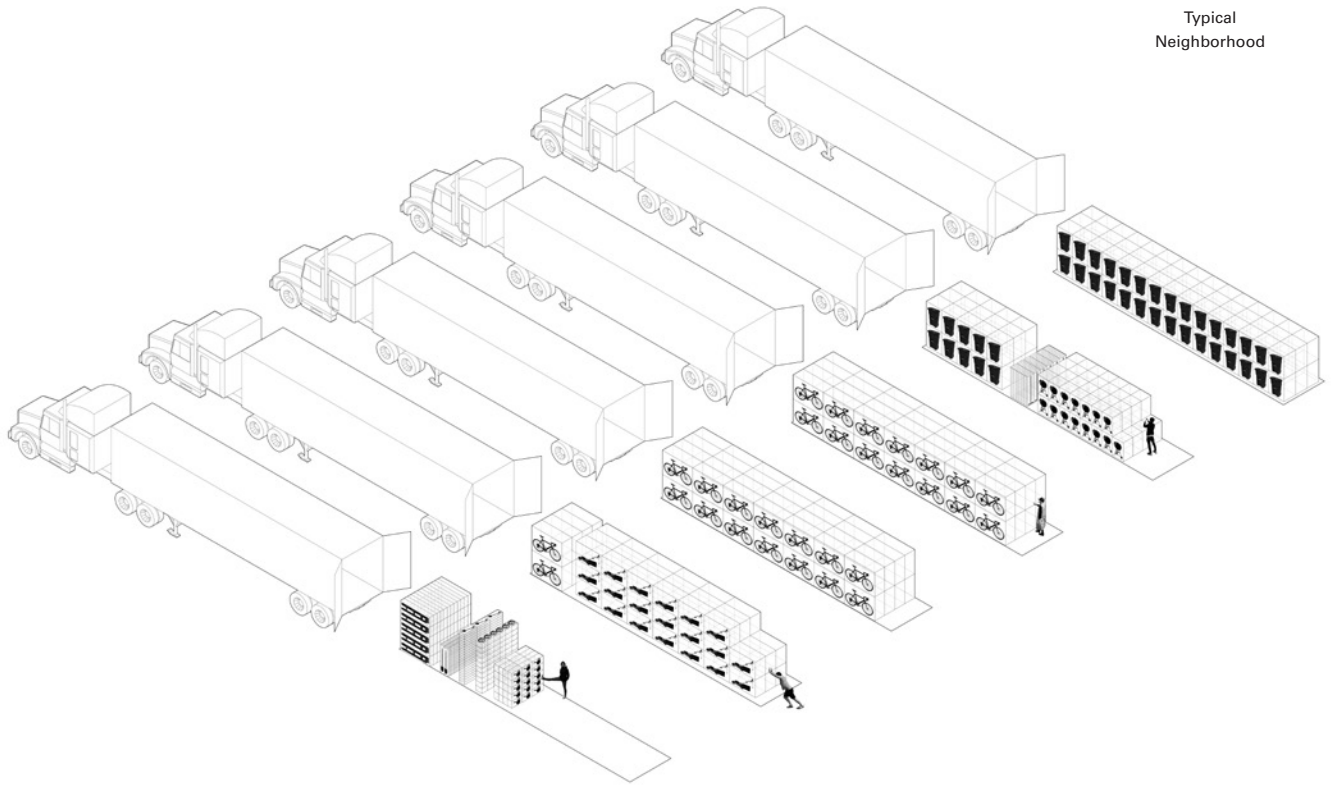

Proposed
Neighborhood

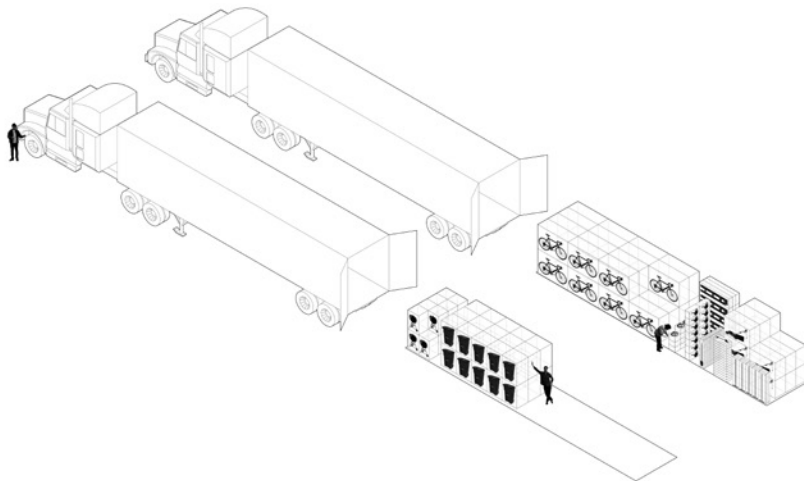

Share Software

A community based upon shared spaces and shared objects would need a software component to both (1) reserve objects and spaces for use and (2) match spatial desires to create compatible units at the outset or to recalibrate units when occupants shift over time.

The software mock-up (right) expresses the project's attitude toward the latter need. One of the exciting aspects of the project is that by sharing, the occupant gets more—tangibly and intangibly—but pays less. The software plays up this aspect by giving the occupant specific examples of what they are gaining while simultaneously showing the diminishing unit cost.

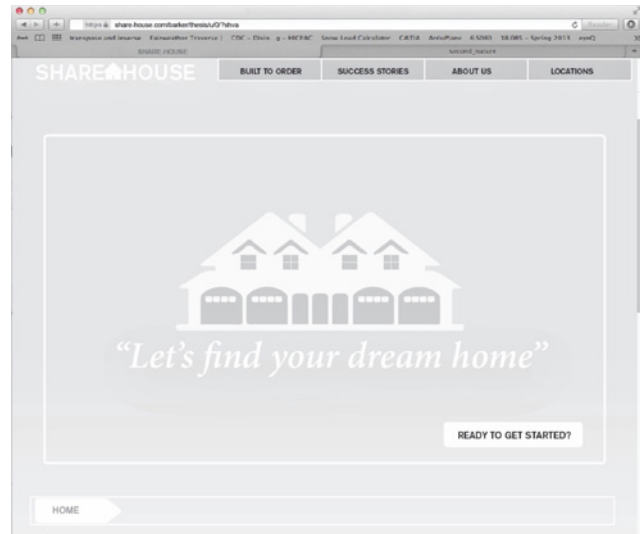

Get started.

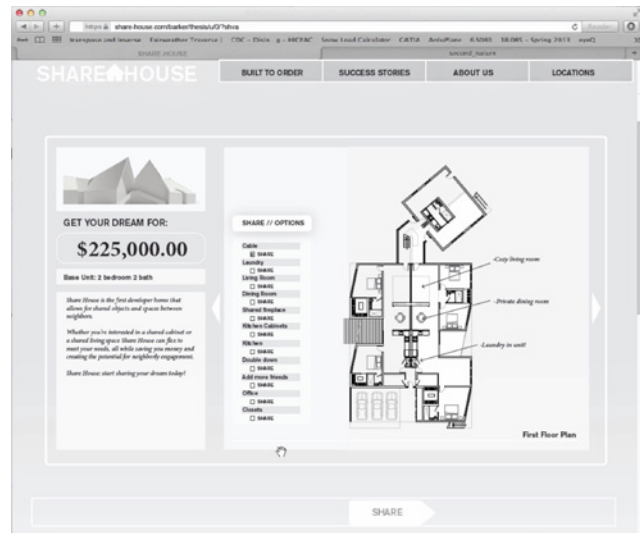

\$225K, before sharing

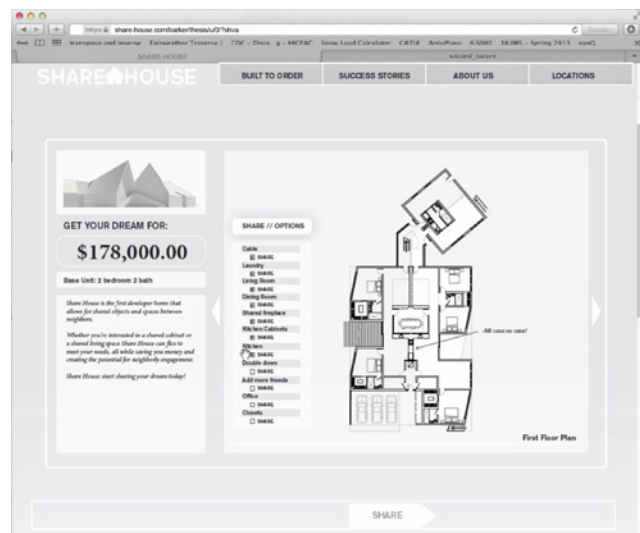

...you pay less, to get more.

Store House

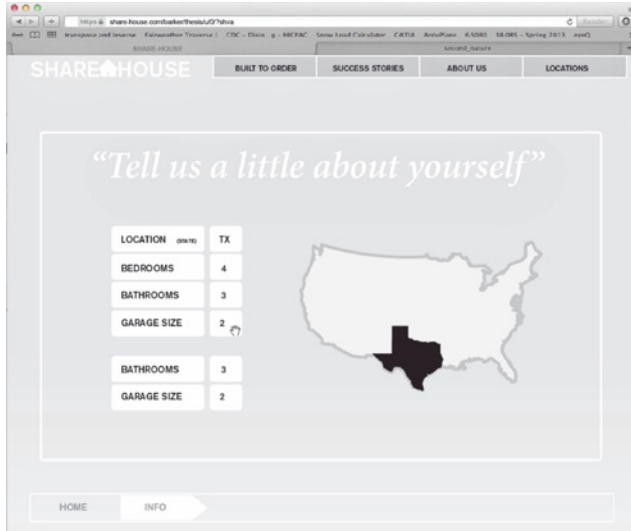

What are you looking for?

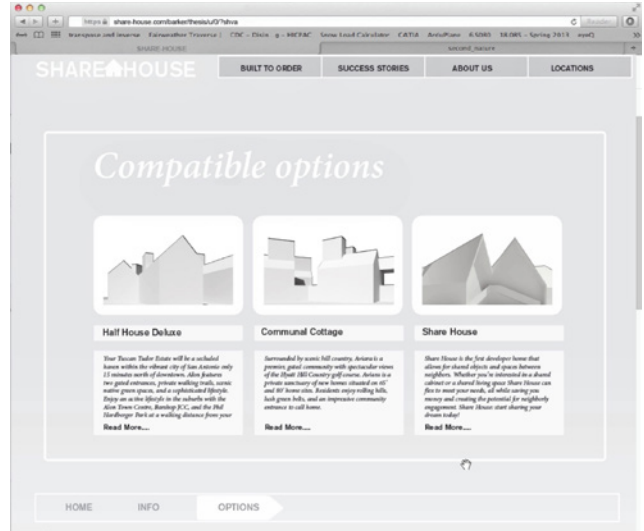

Chose the model.

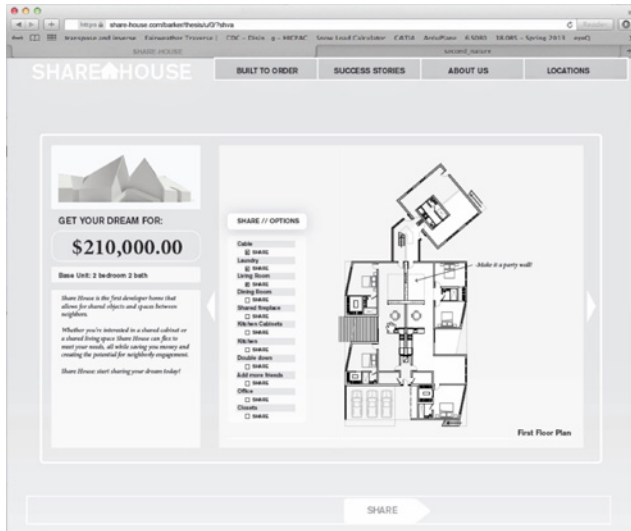

As more amenities are shared, the price drops.

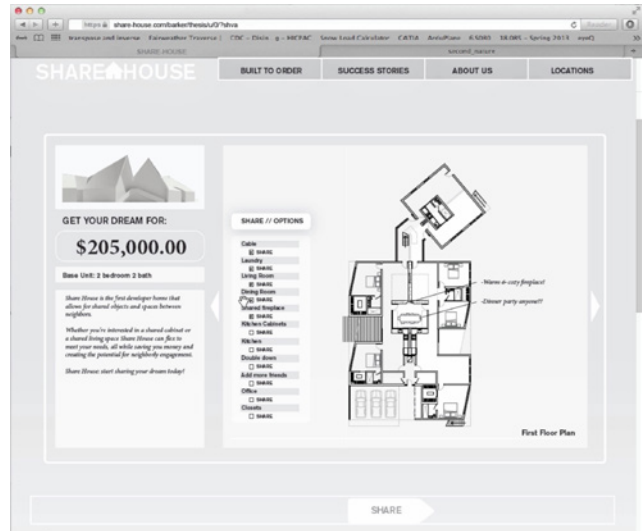

In this way, it is the opposite of the current model...

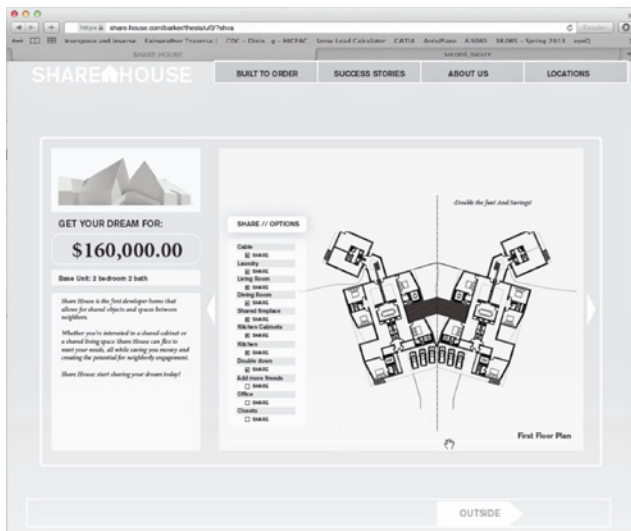

As more people design their dream home, matches are made.

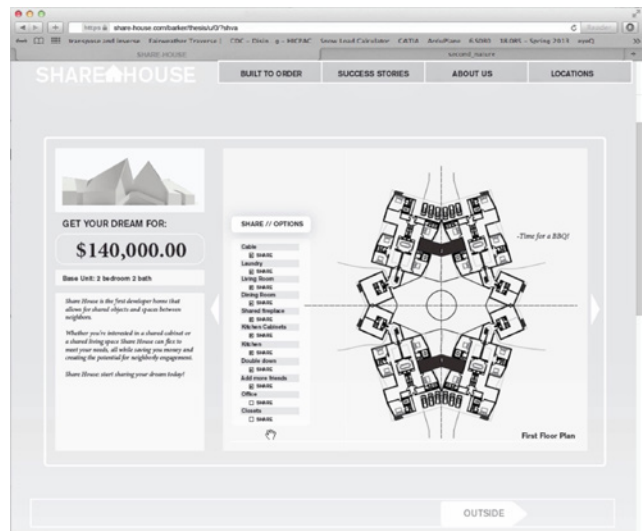

Differences create spatial compatibility across the community.

Mobile Residential Storage

—
For this study of a mobile storage device, the standard shipping container (also used for most semi-trucks' cargo) set the dimension: each unit is one-third of a container. The units are hinged to enable different spatial configuration and to allow them to maneuver through doorways. This idea is compatible with the final project, but not explicitly part of it.

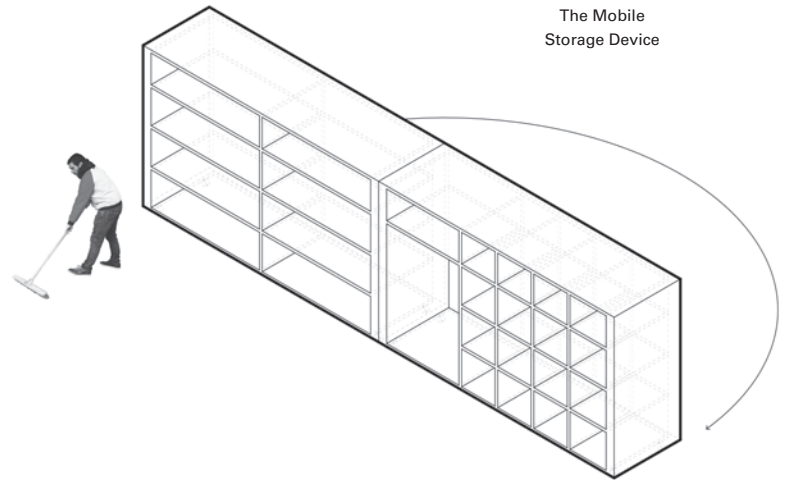

192

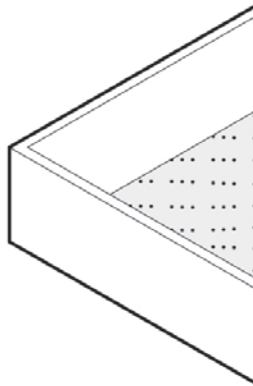
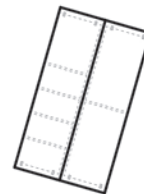
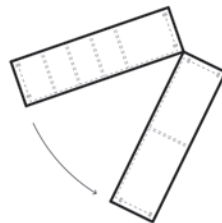
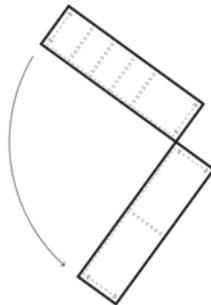
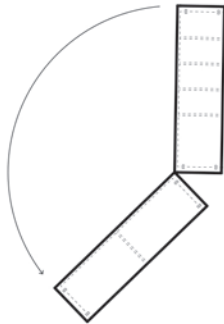
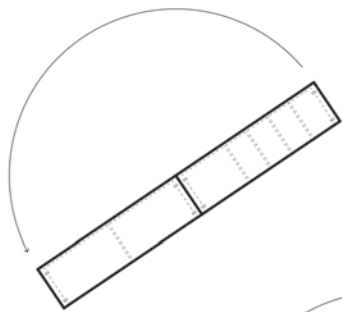

Possible Configurations

Store House

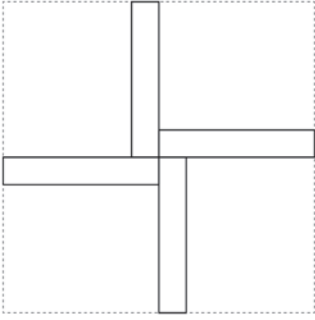

Pinwheel
Storage Poche

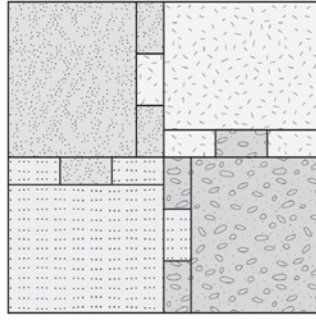

Units + Storage:
Jagged Threshold

The arrangement below is based on the average square footage for the American house. The jogged wall creates: access to the exterior for receiving new storage units or returning old ones; a registration of one's neighbors; and the ability to create alcoves via storage.

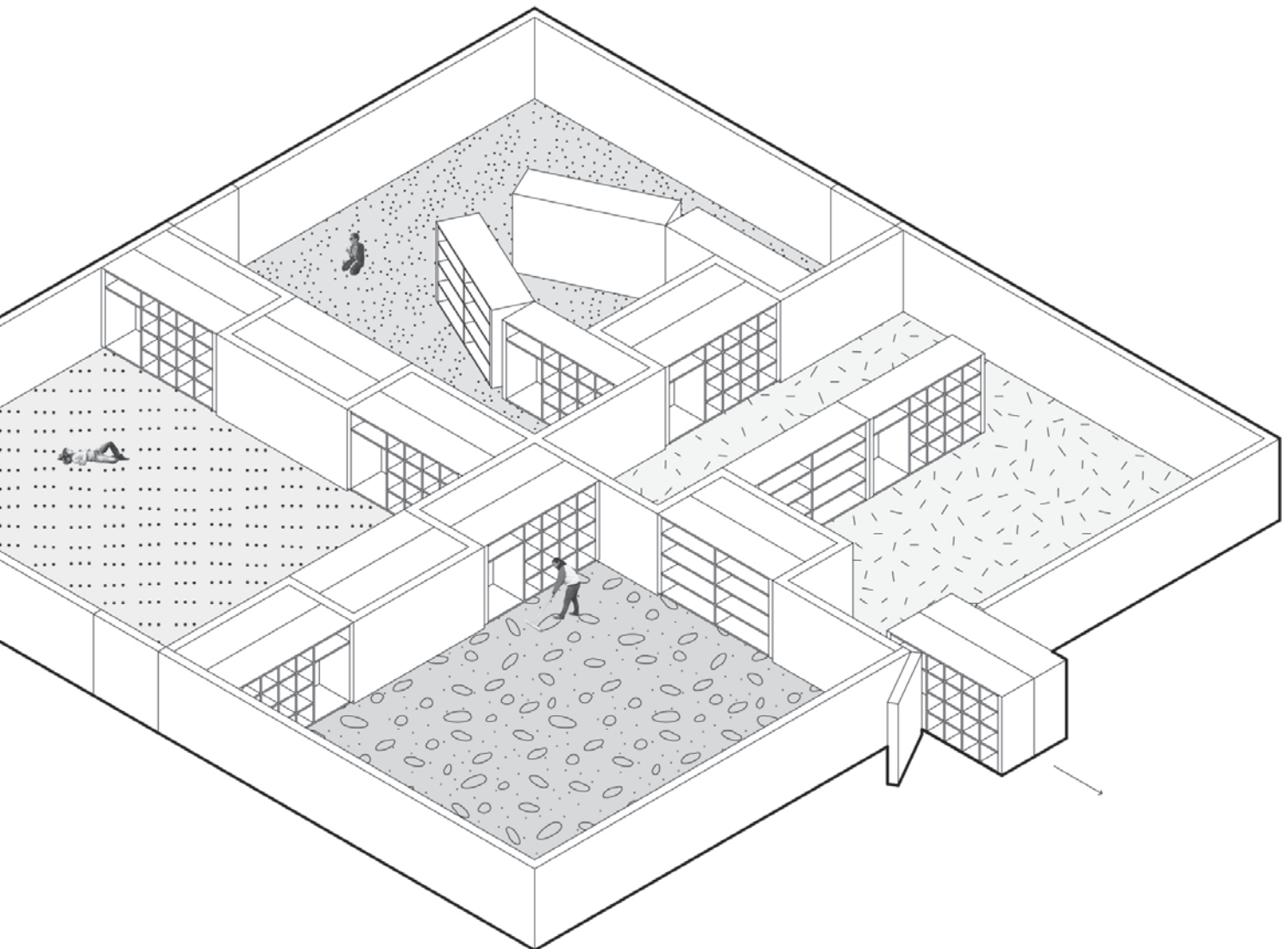

The Process of Loading on to a Semi-Truck

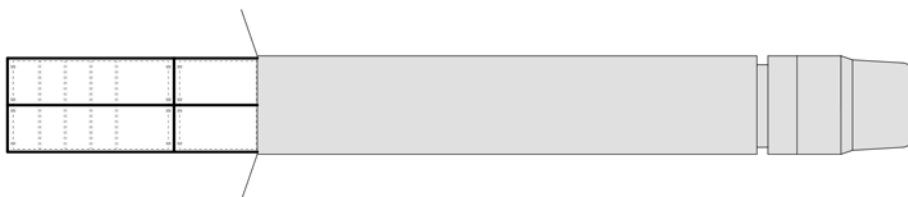
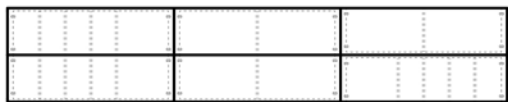
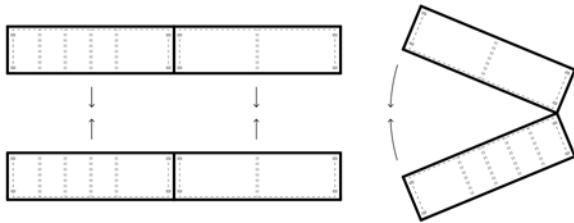
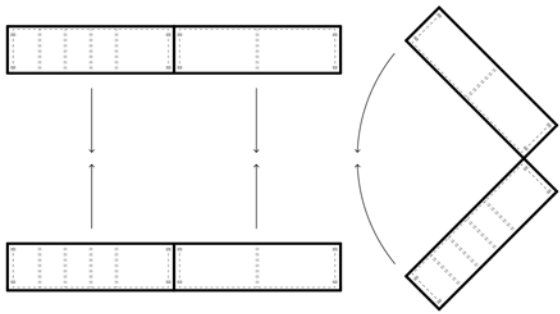

Lifestyle Modules

—
So much of the stuff that we accumulate over time is tied to phases of life that demand particular consumption patterns. For example, babies need cribs, car seats & strollers that they rapidly outgrow. Teenagers want a guitar one week and a BMX bike the next.

What would happen if the emerging membership model of ownership jumped to the scale of the room? Could we borrow the objects that populate the phases of our lives rather than buying them?

One can imagine a version of this that allows a portion of the home's storage program to function as a portable "plug & play" module that adapts to the resident's changing needs. How could responsible consumption be re-branded as "just-in-time" ownership?



The Newborn Module



The Child Module

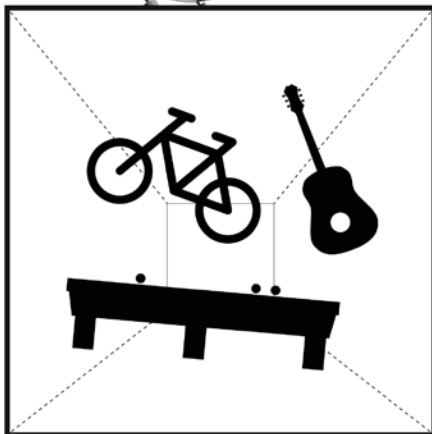

The Adolescent Module



The Empty Nester Module

Wall Studies

—
A look at the interface between units:
sharing at the smallest and most personal
scale. Some of these made it into the
final project, but some were meant
merely as a means of establishing
extremes on the spectrum of possibili-
ties. A few in the second round of inves-
tigation are named after the architects
that inspired them.

196



Interlocking Crawl Space
Scale 1/4" = 1'-0"

Store House

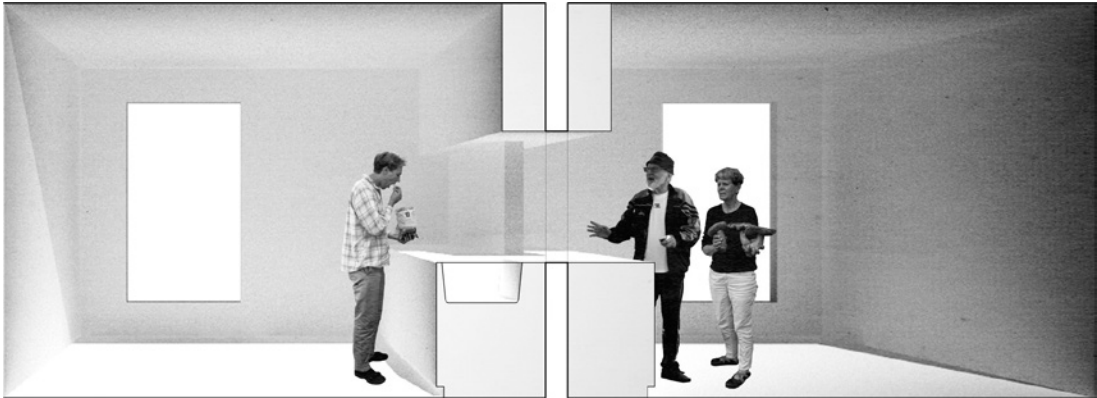

Communal Kitchen
Scale 1/4" = 1'-0"

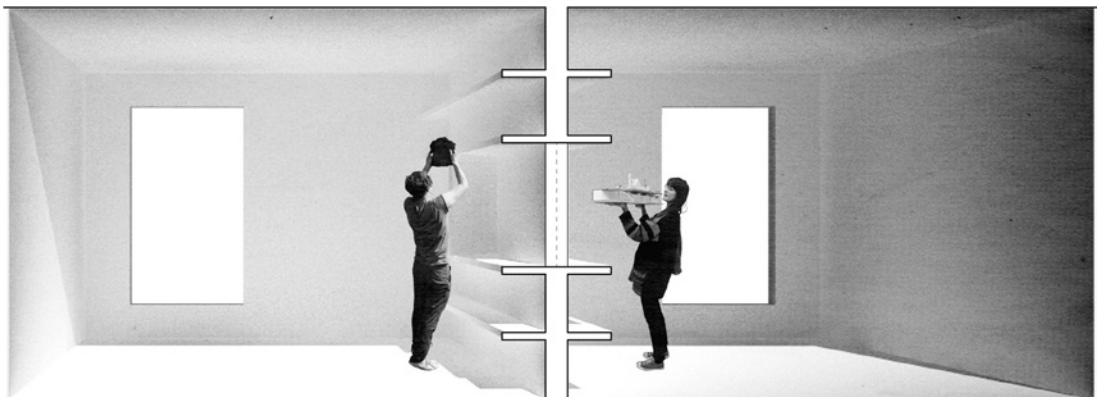

Shared Shelving
Scale 1/4" = 1'-0"

The Appendix

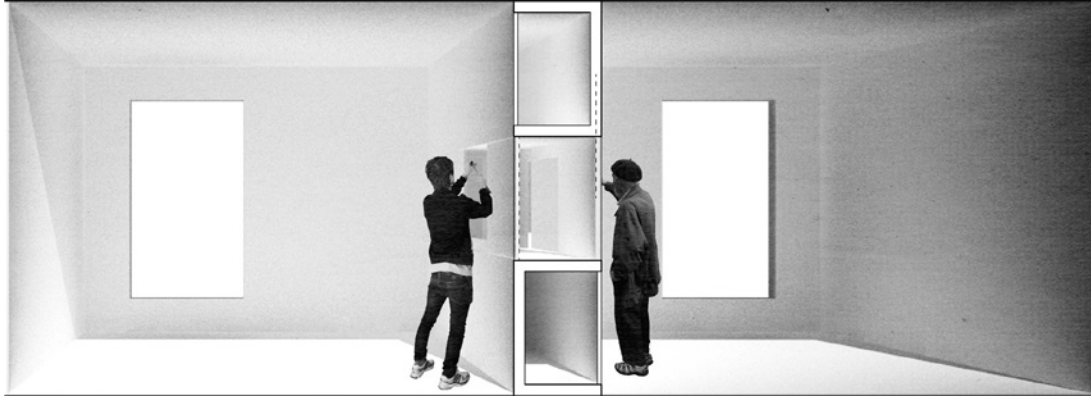

Collaborative Console
Scale 1/4" = 1'-0"

198

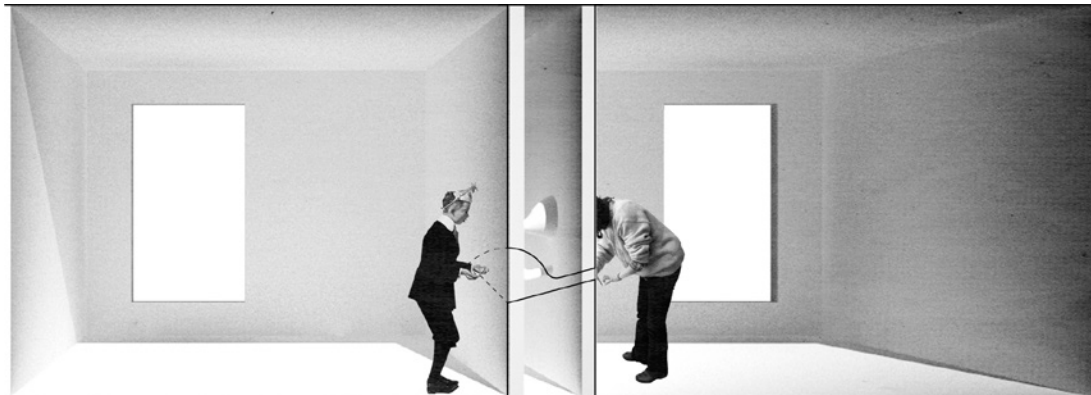

Gift Exchange
Scale 1/4" = 1'-0"

Store House

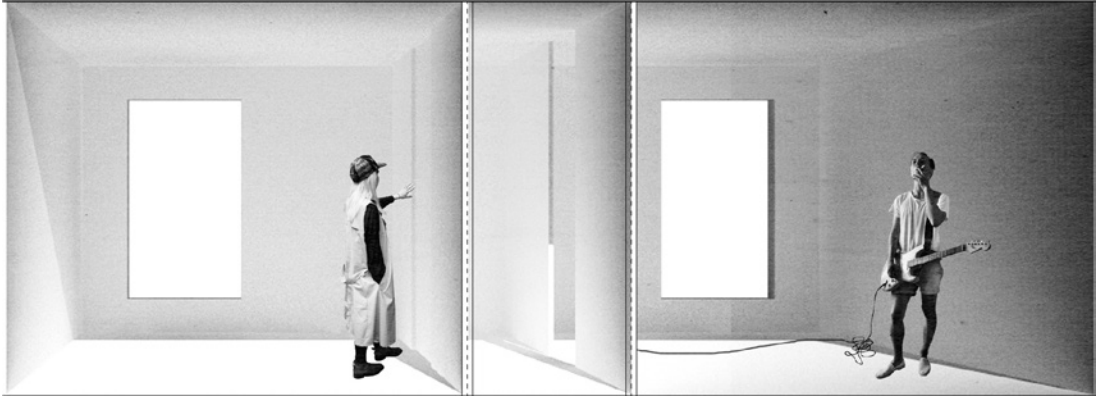

Sliding Storage
Scale 1/4" = 1'-0"



Double Garage
Scale 1/4" = 1'-0"

The Appendix

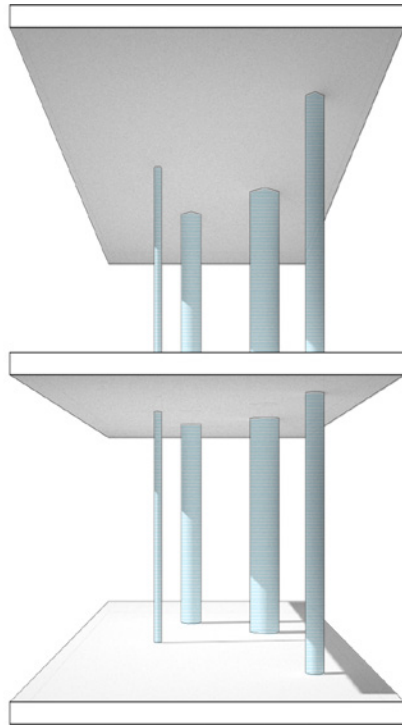

Pneumatic Tubes (The Ishigami)
Scale 1/4" = 1'-0"

200



Pneumatic Tubes (The Ishigami)
Scale 1/4" = 1'-0"

Store House



Crank-to-Share Shelving
Scale 1/4" = 1'-0"

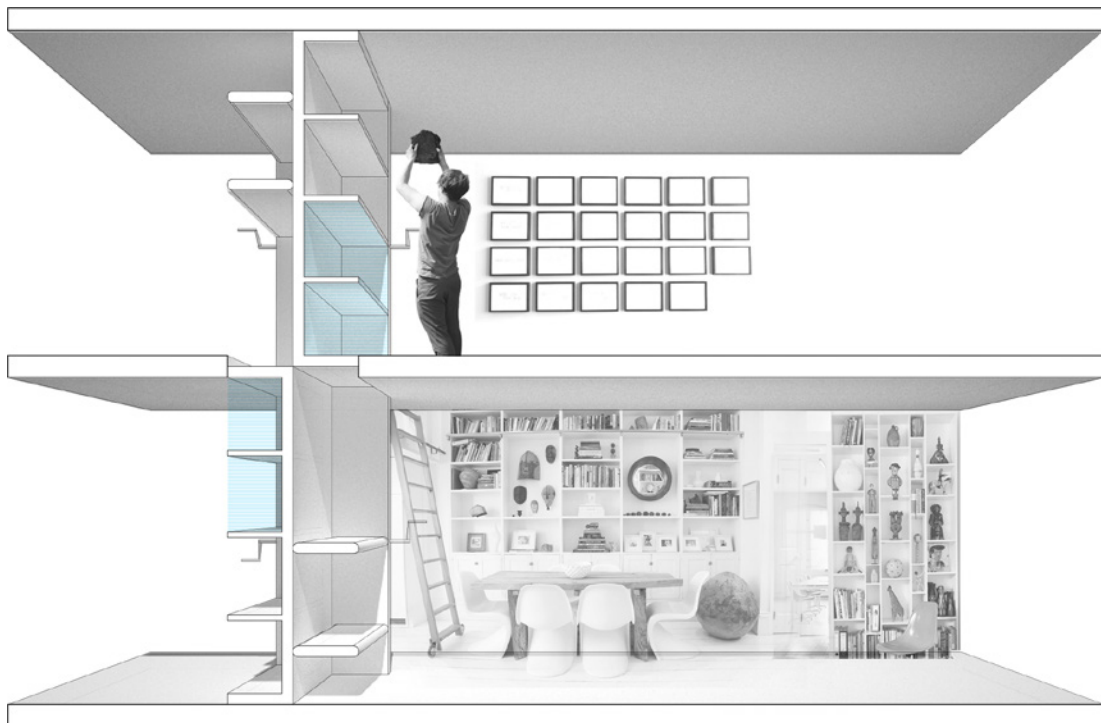

Crank-to-Share Shelving
Scale 1/4" = 1'-0"

The Appendix

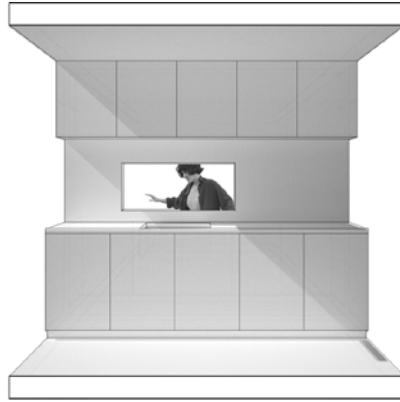

Peekaboo View from the Sink
Scale 1/4" = 1'-0"

202

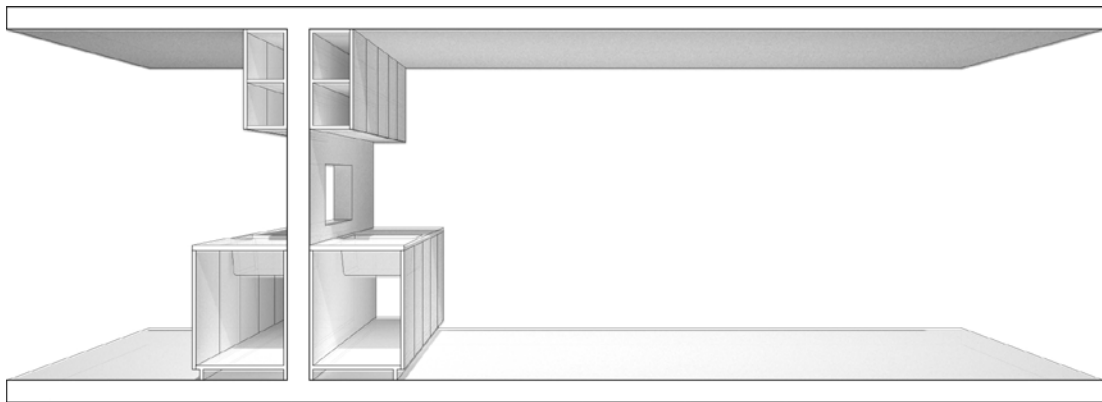

Peekaboo View from the Sink
Scale 1/4" = 1'-0"

Store House



Peekaboo Base / Wall Cabinet
Scale 1/4" = 1'-0"

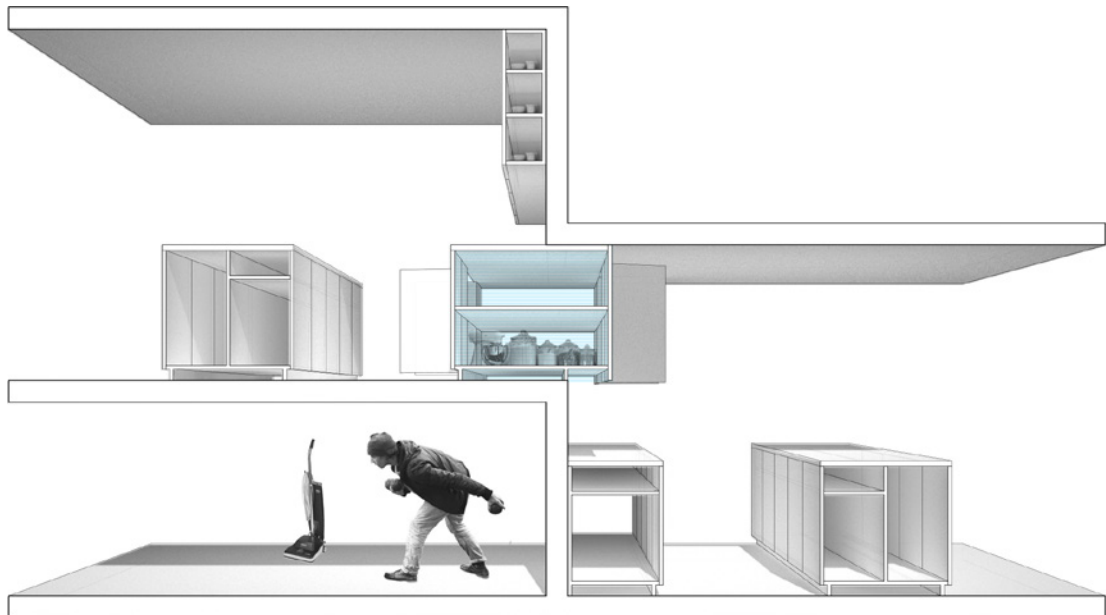

Peekaboo Base / Wall Cabinet
Scale 1/4" = 1'-0"



Peekaboo Cabinet, from Kitchen to Garage (The Stirling)
Scale 1/4" = 1'-0"

204

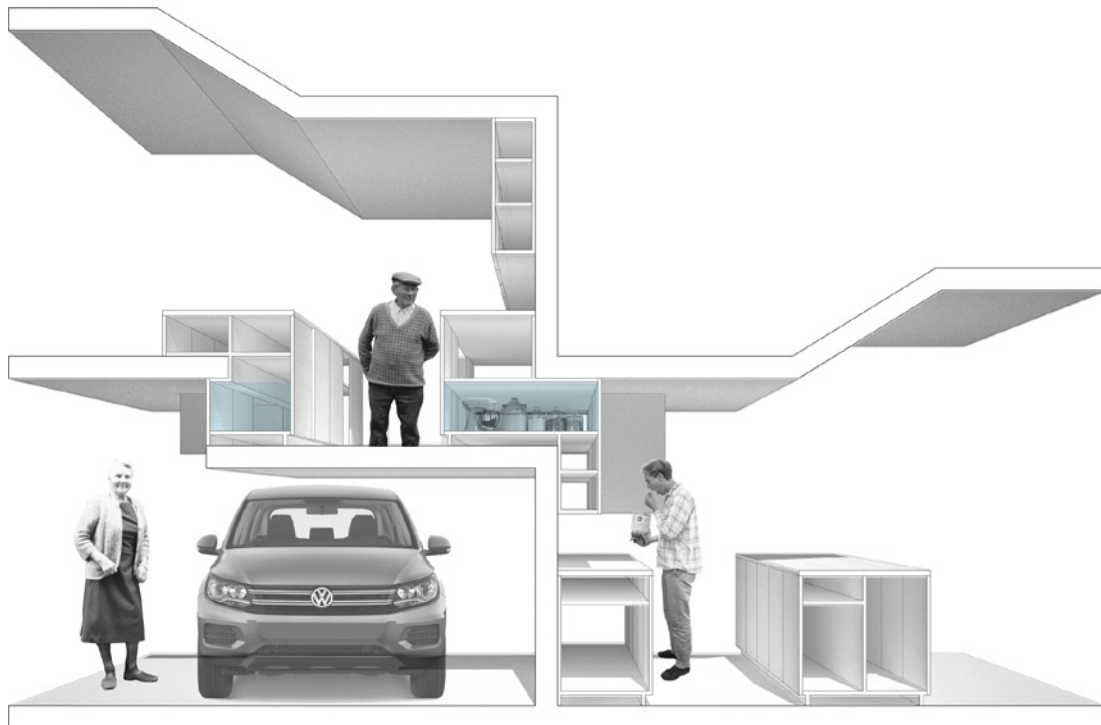

Peekaboo Cabinet, from Kitchen to Garage (The Stirling)
Scale 1/4" = 1'-0"

Store House

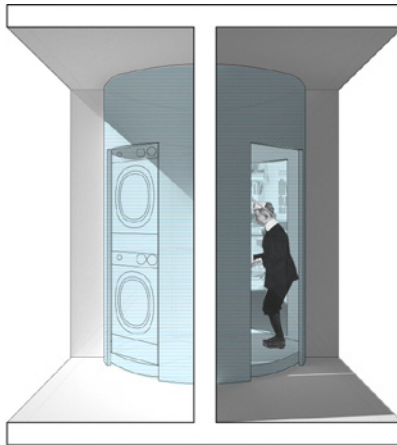

The Laundry Turntable (The Botta)
Scale 1/4" = 1'-0"

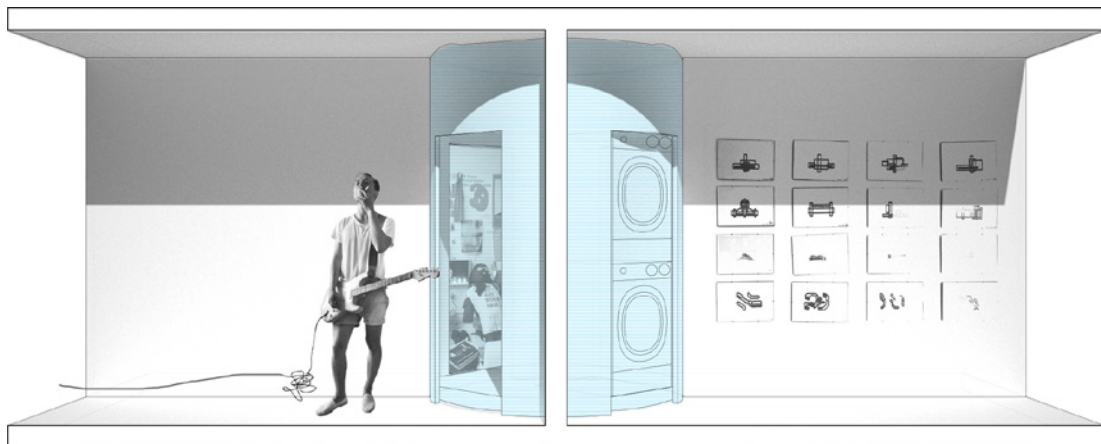

The Laundry Turntable (The Botta)
Scale 1/4" = 1'-0"

The Appendix

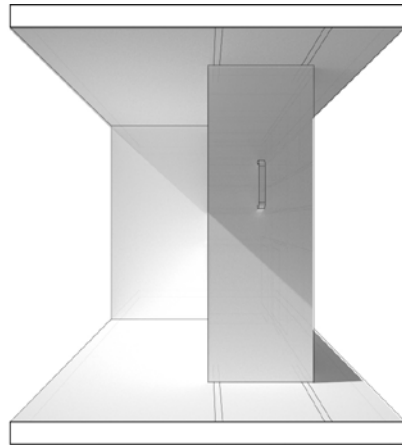

Sliding Bookcase (The Fujimoto)
Scale 1/4" = 1'-0"

206

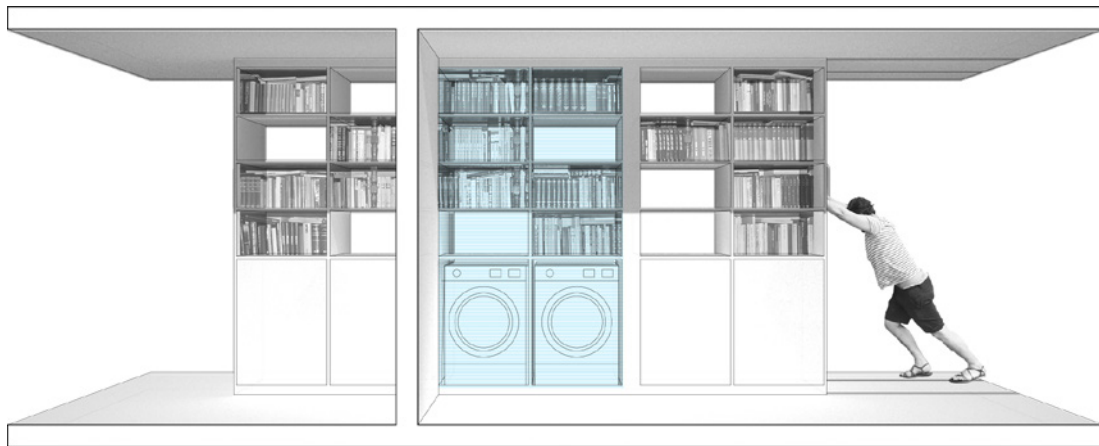

Sliding Bookcase (The Fujimoto)
Scale 1/4" = 1'-0"

Store House

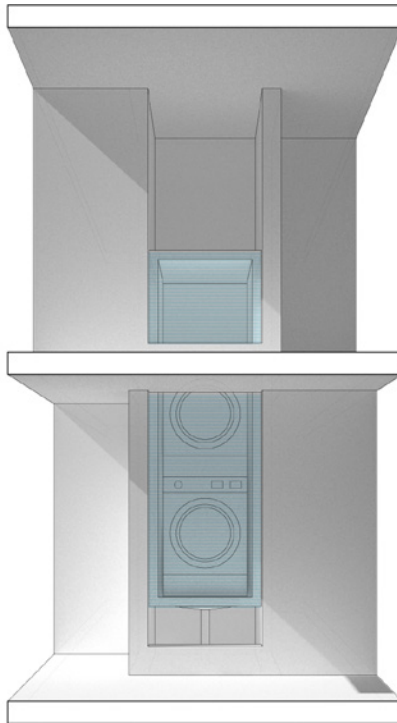

Pneumatic Laundry (The Koolhaas)
Scale 1/4" = 1'-0"



Pneumatic Laundry (The Koolhaas)
Scale 1/4" = 1'-0"

Operative Diagrams

The next six pages show the diagram-drawings from the “Scale of Sharing” section with the roofs intact.

When I cut L’Atessa di Vita into individual components (to begin rearranging it as a means of discovering new domestic relationships) I kept the original roof with each piece. For the final drawings, I turned that layer off to show the interior organization, but I include the drawings here because they helped to inform aspects of the final massing.

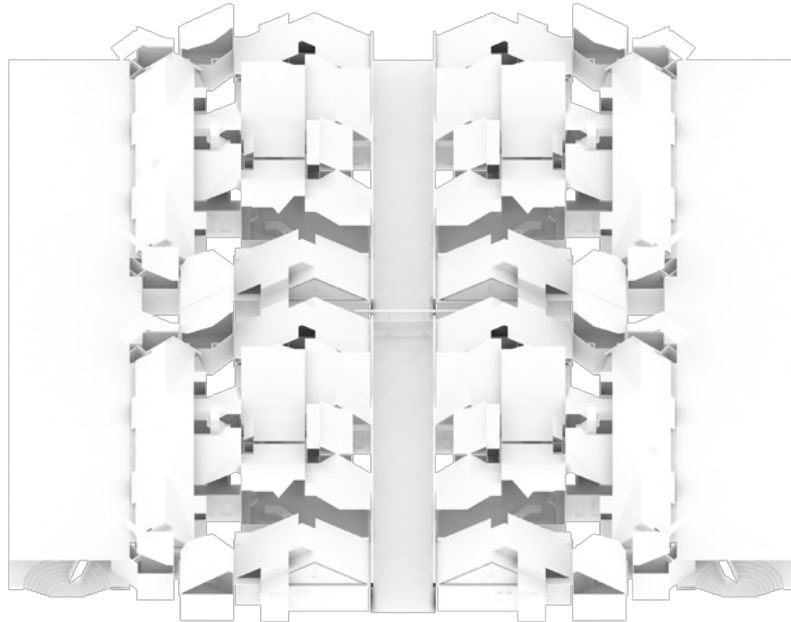

Store House

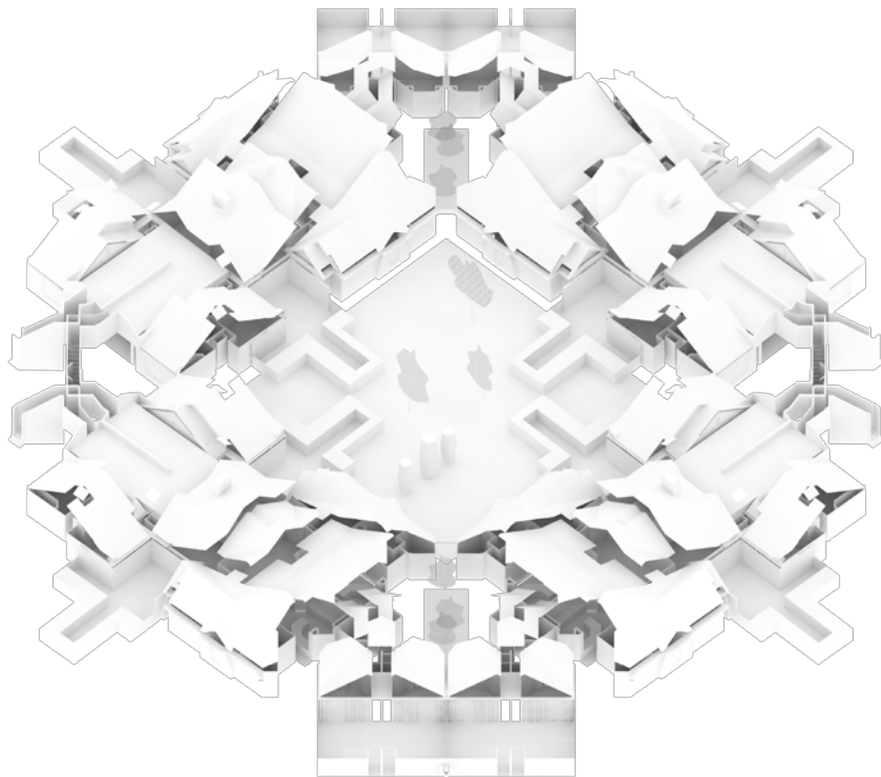
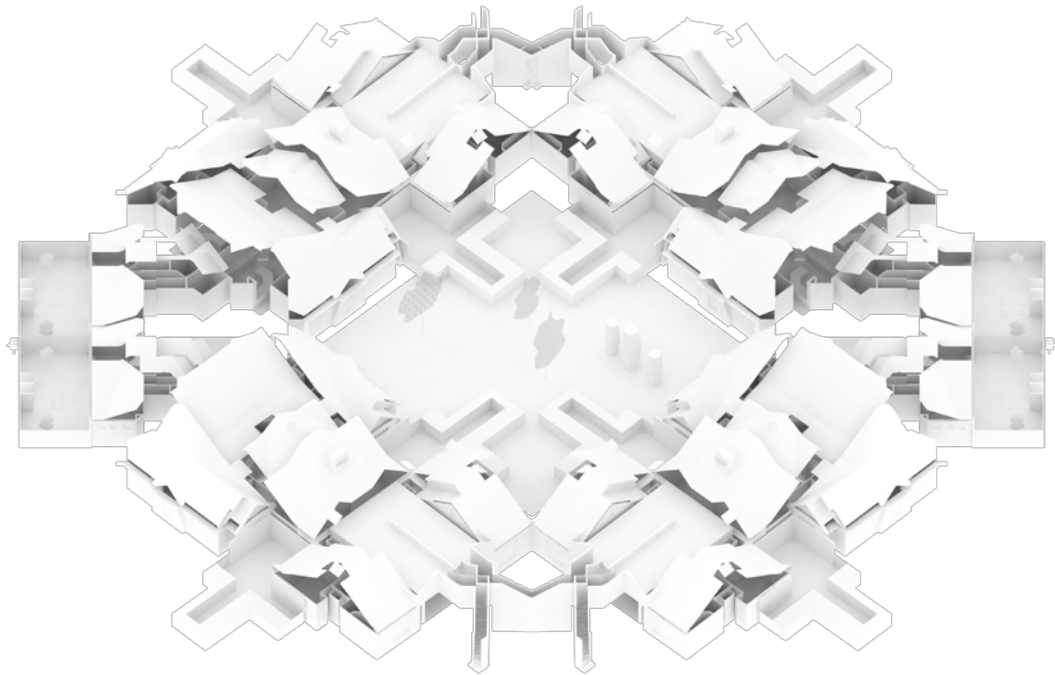

The Appendix

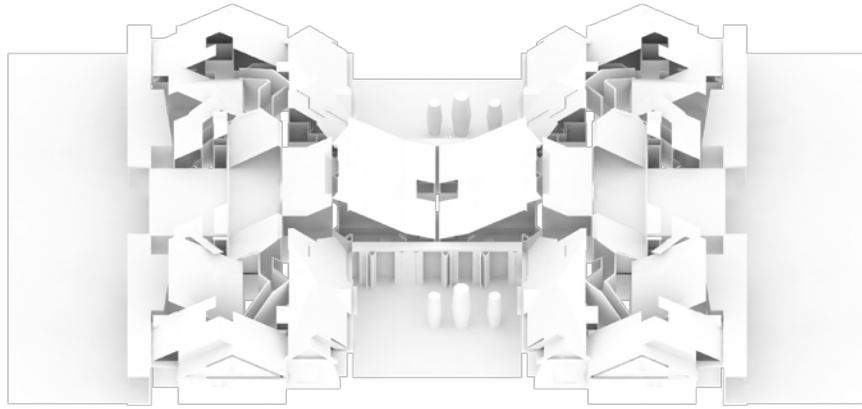

210

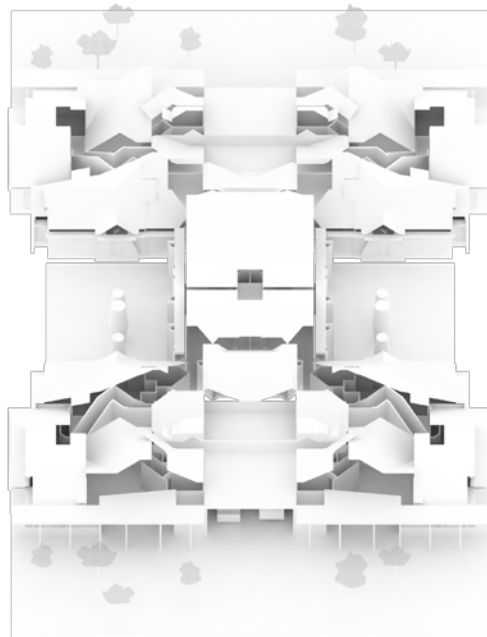

Store House

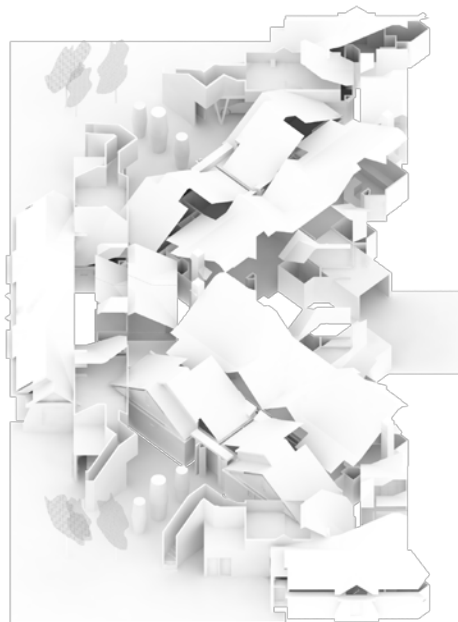
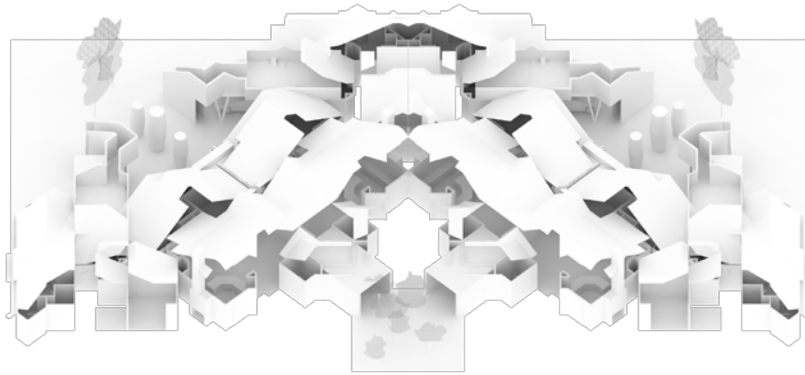

The Appendix

The Quadplex with Roof



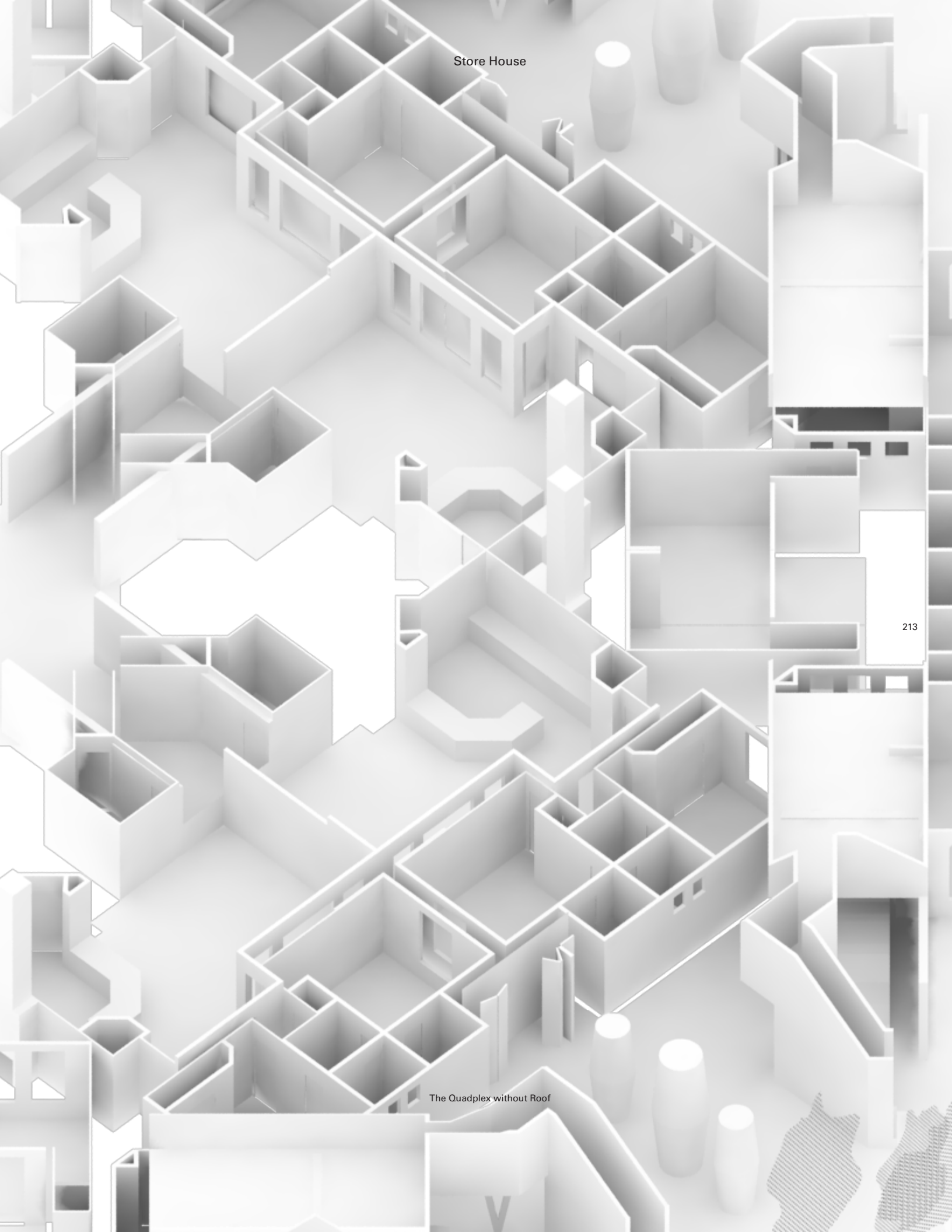

Store House

The Quadplex without Roof

ii

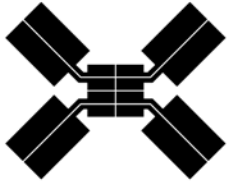

ii



ii

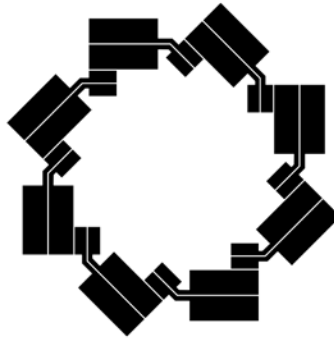

ii



ii

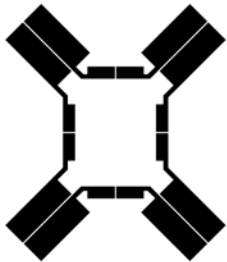

ii



ii



ii



ii



ii

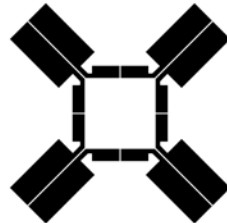

ii



ii

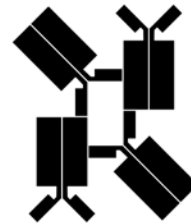

ii

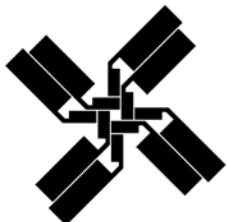

ii



ii

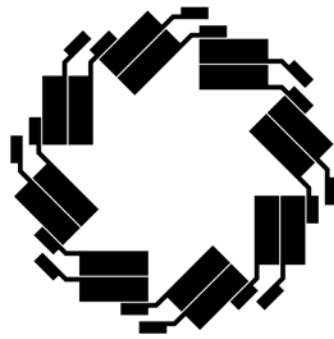

ii

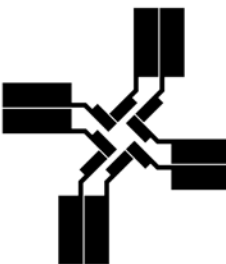

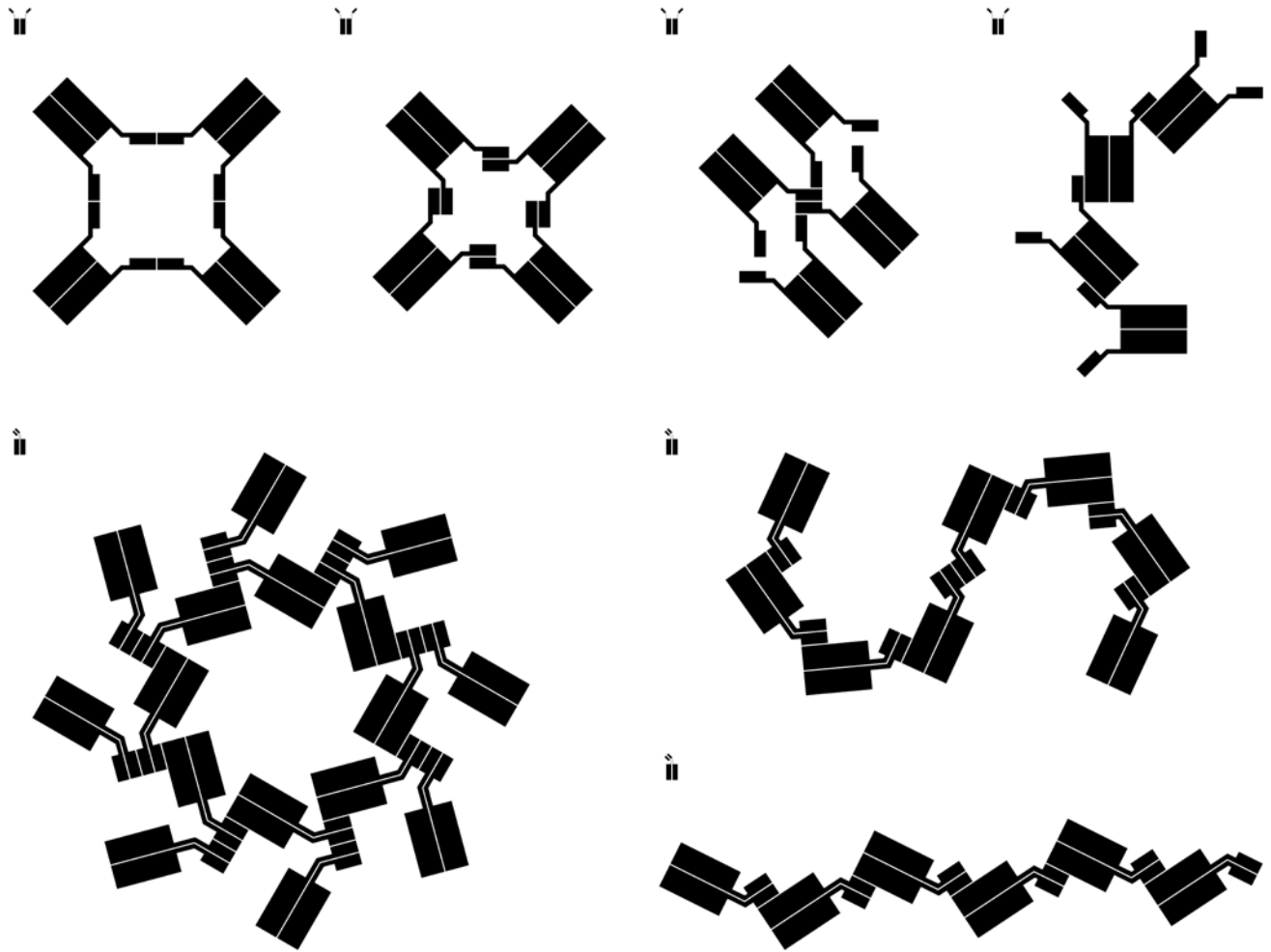

Unit Cluster Studies

—

A series of cluster tests using the two halves of the final unit. The small drawings to the upper left of each option show the "ingredient" for each cluster.

Site Studies

The next twelve pages explore a range of site possibilities through physical and digital modeling. These studies were primarily about unit and unit-clustering on site (other site fundamentals such as pedestrian and vehicular circulation, relationship with existing structures, etc) were more squarely addressed through other studies.

216

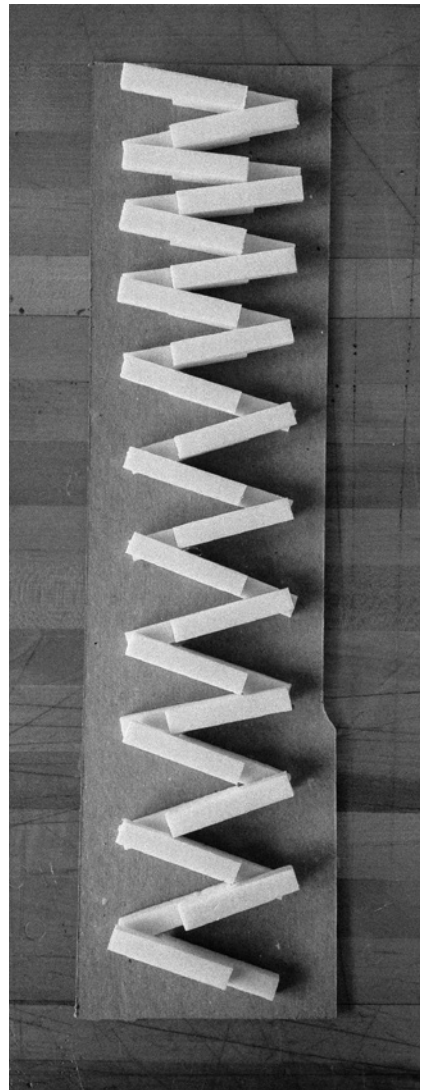
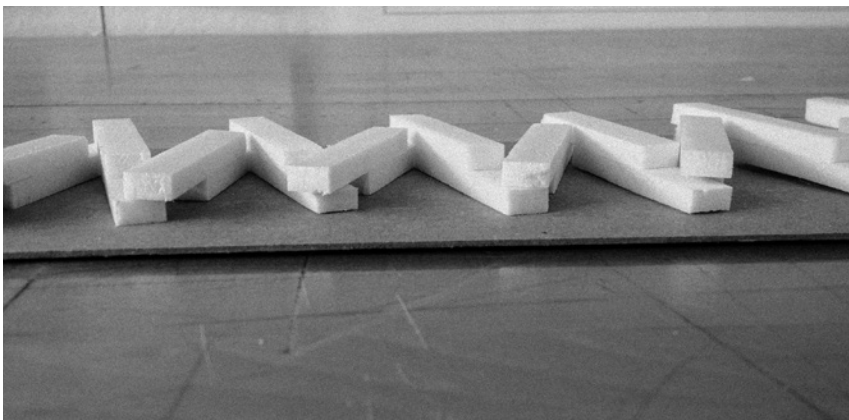

Store House

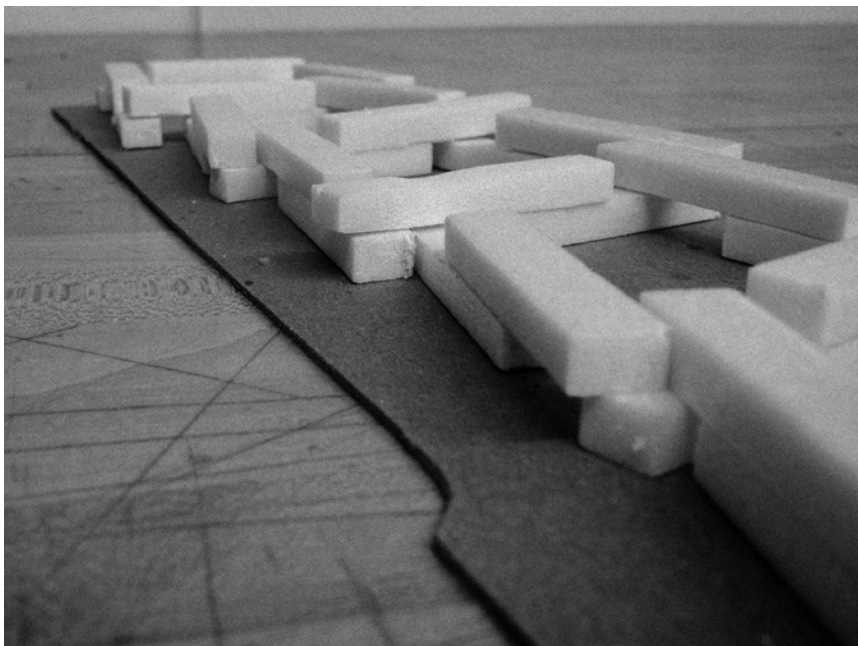
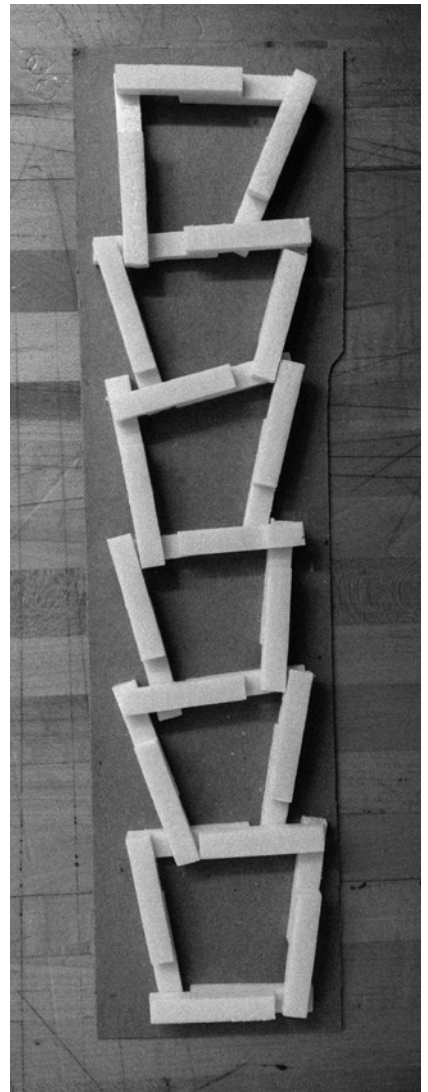
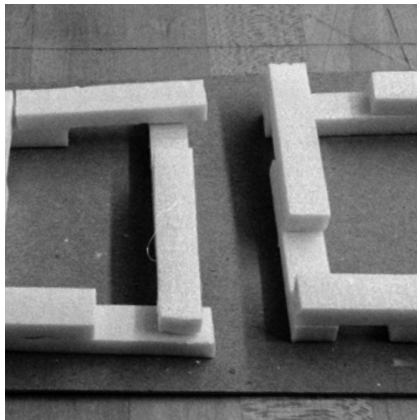
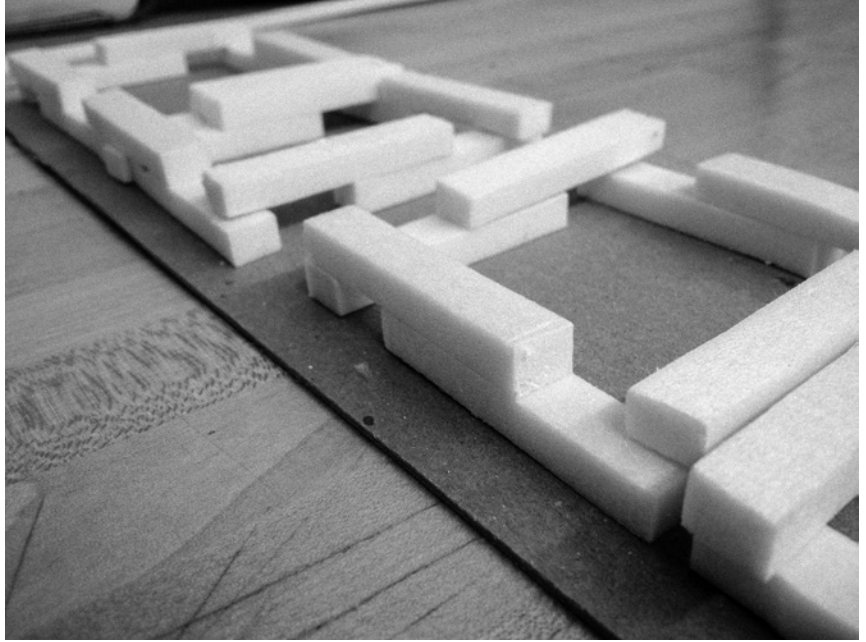
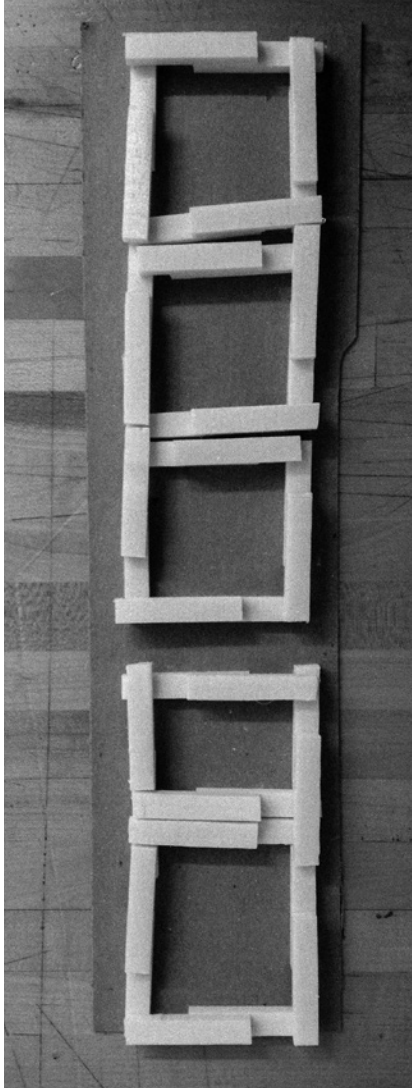



218

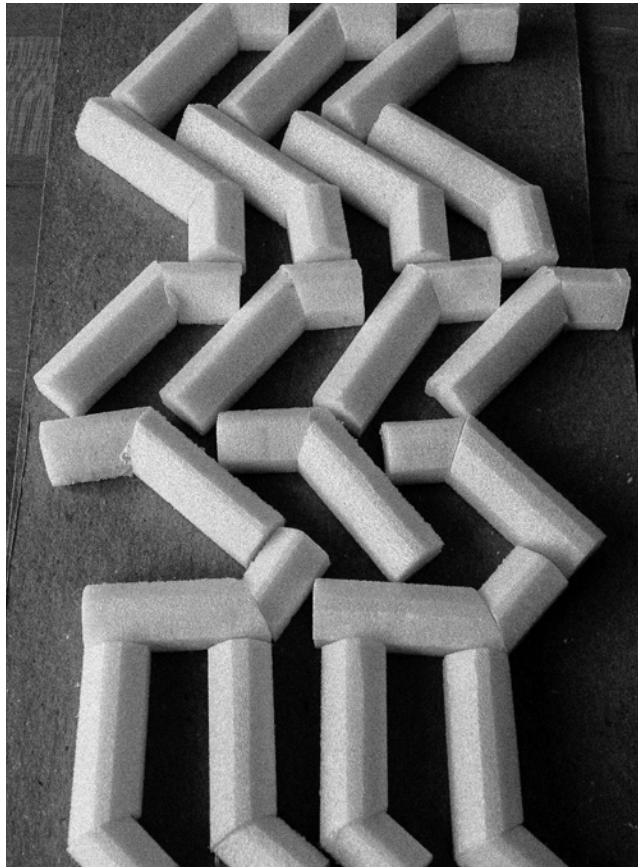
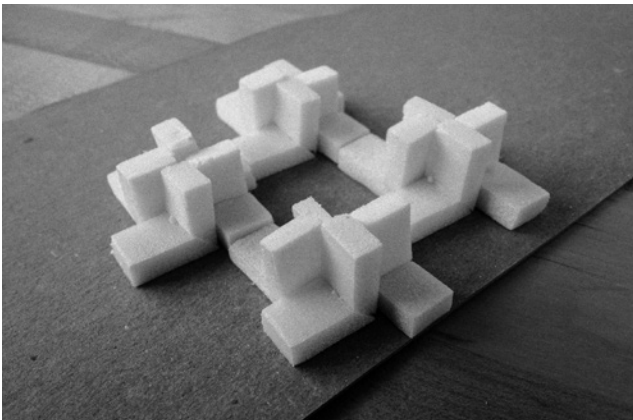
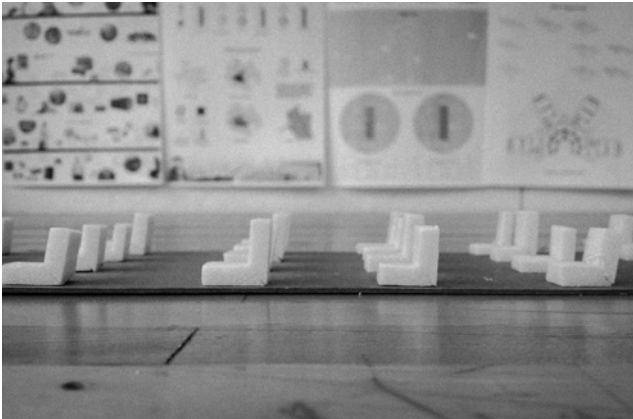

Store House

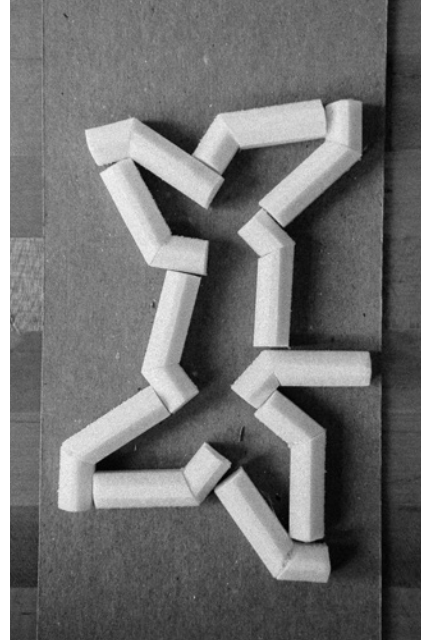

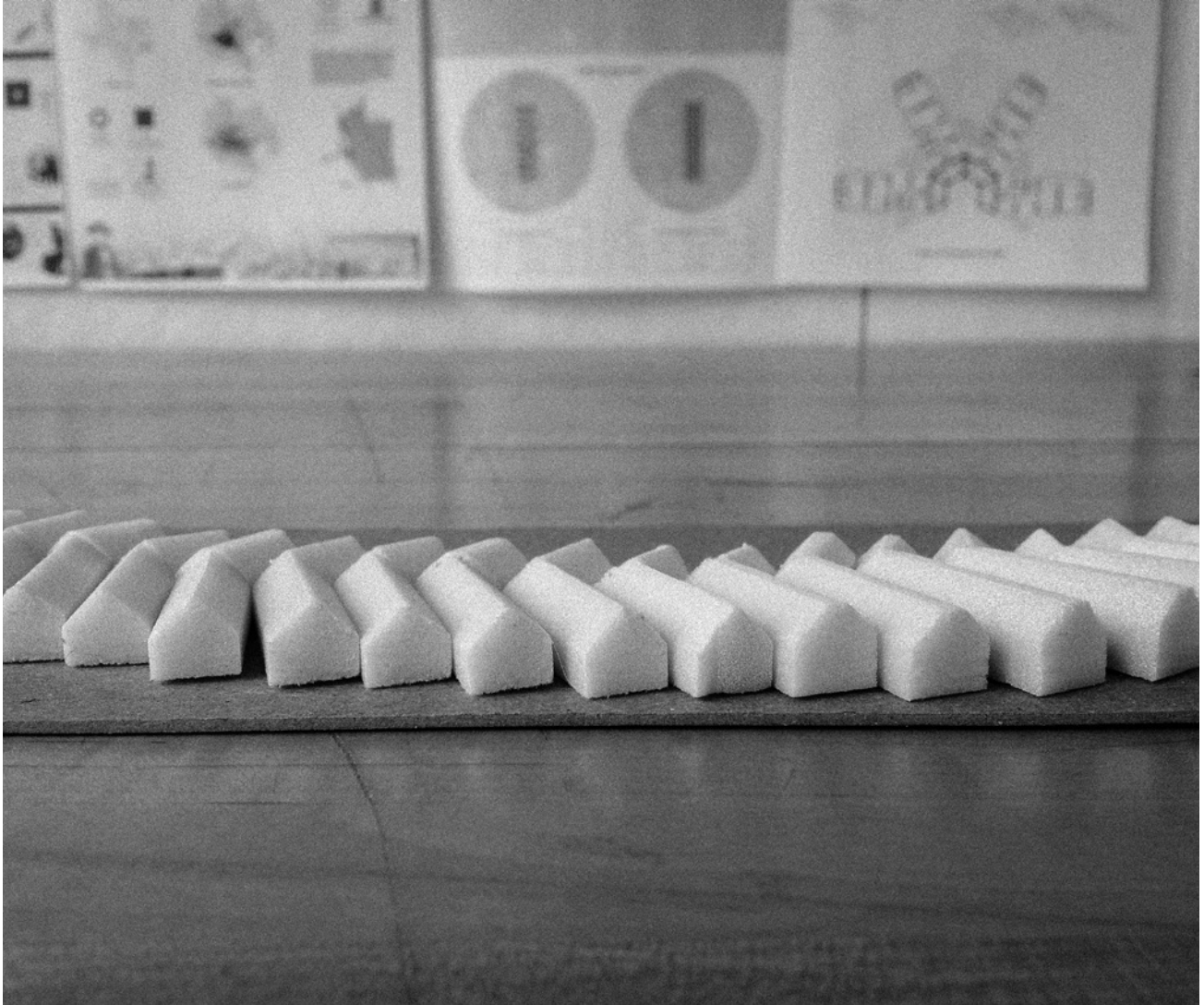

220

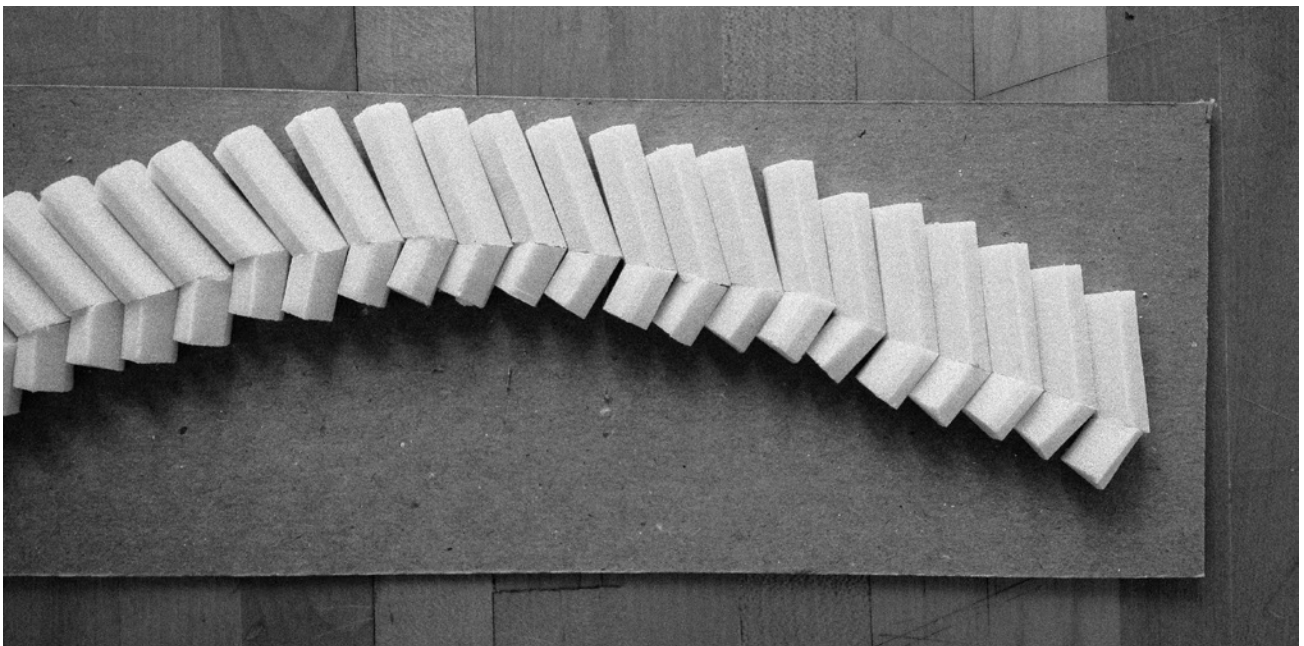

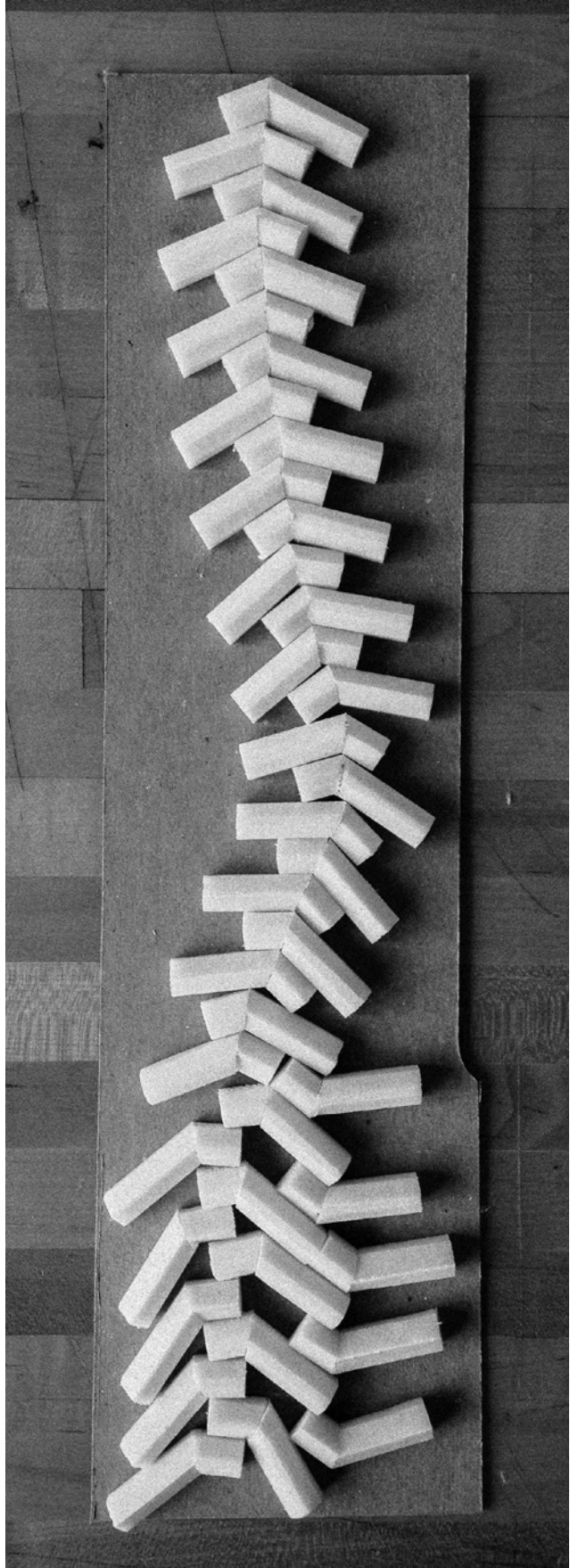
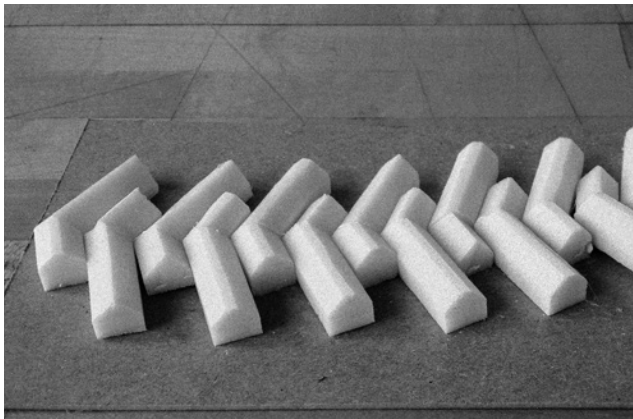
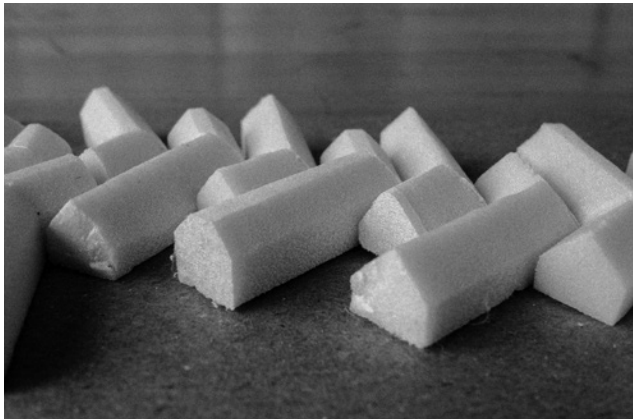

The Appendix

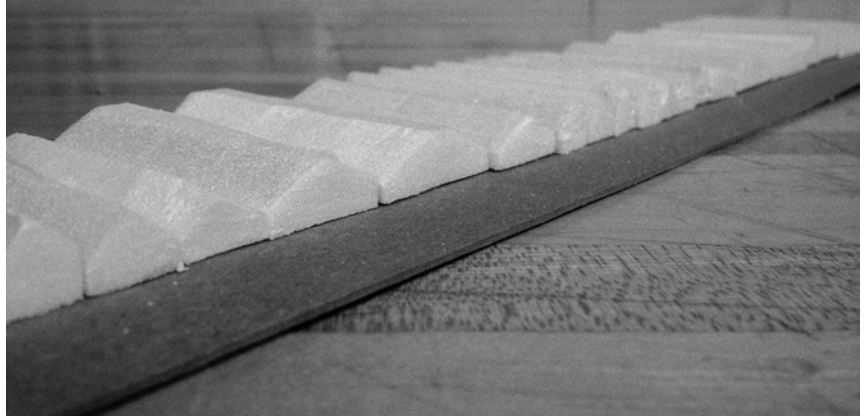
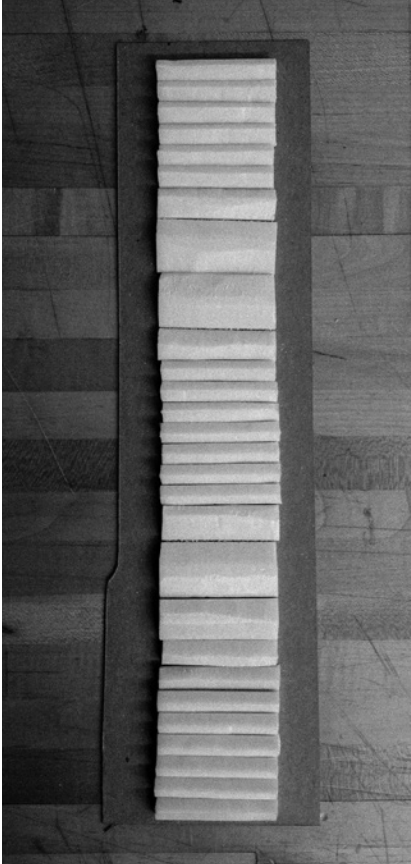

222

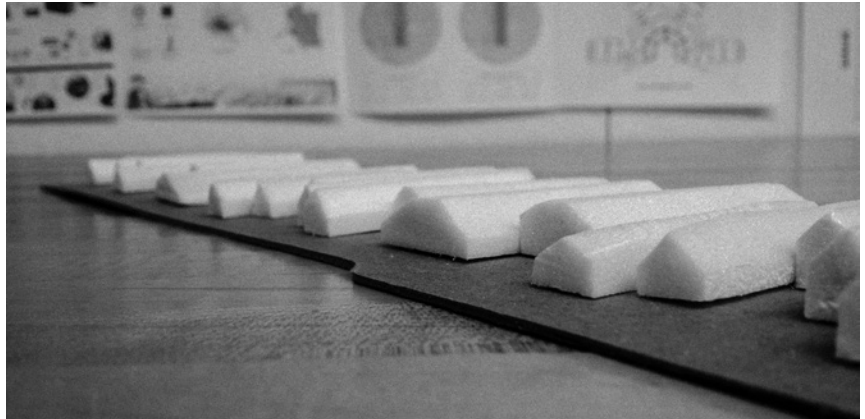
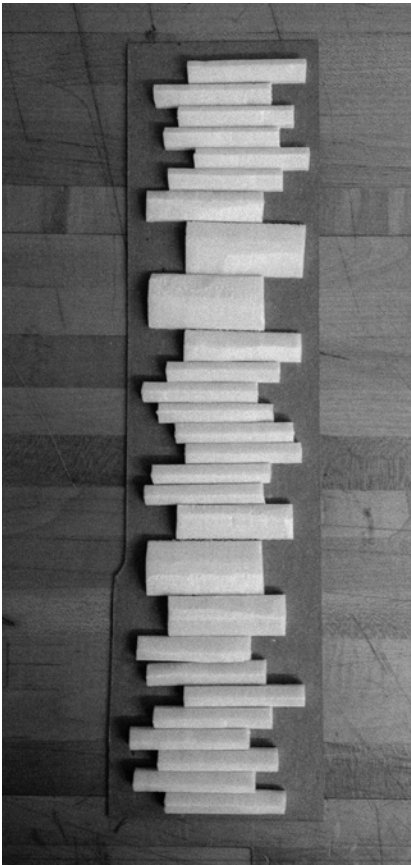

Store House

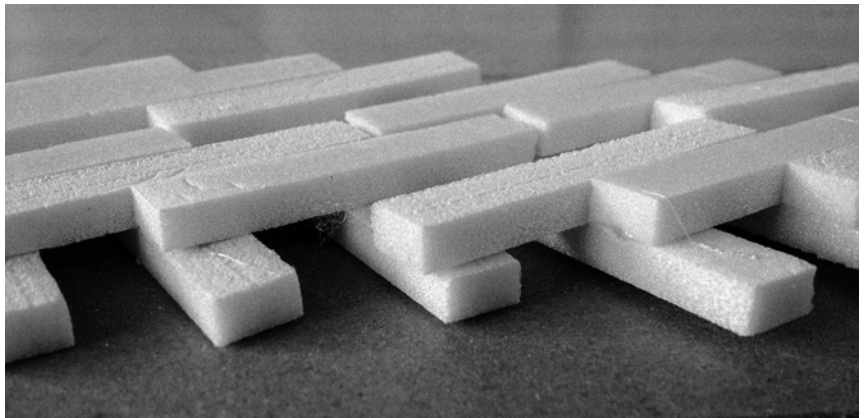
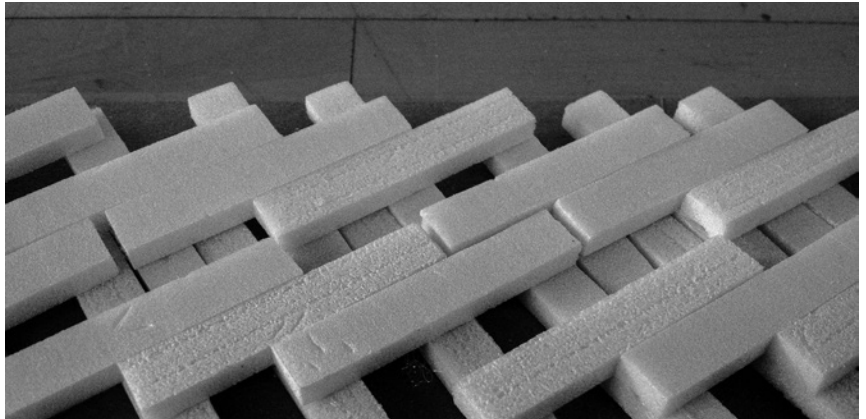
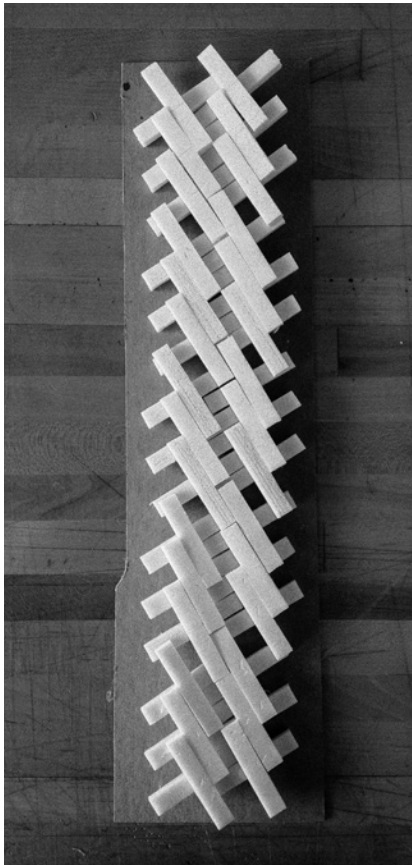
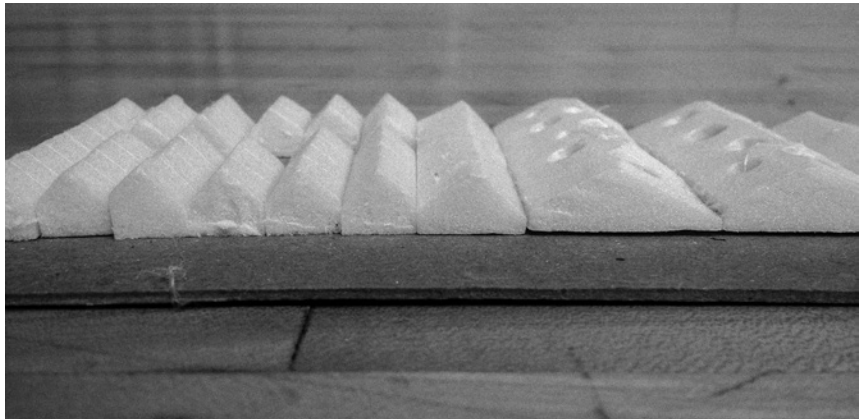
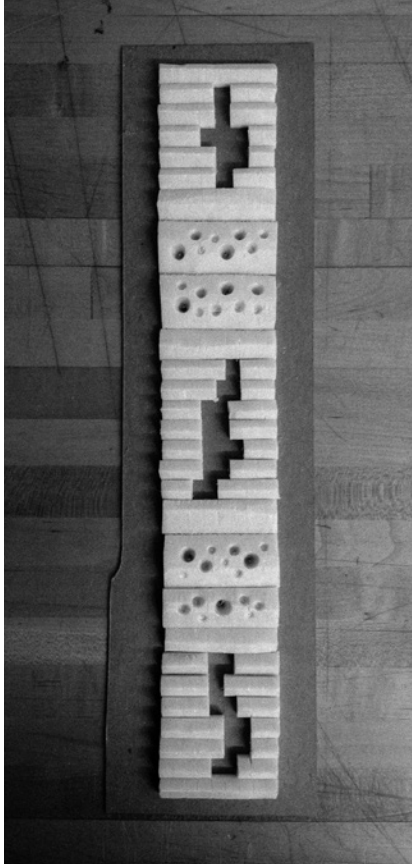

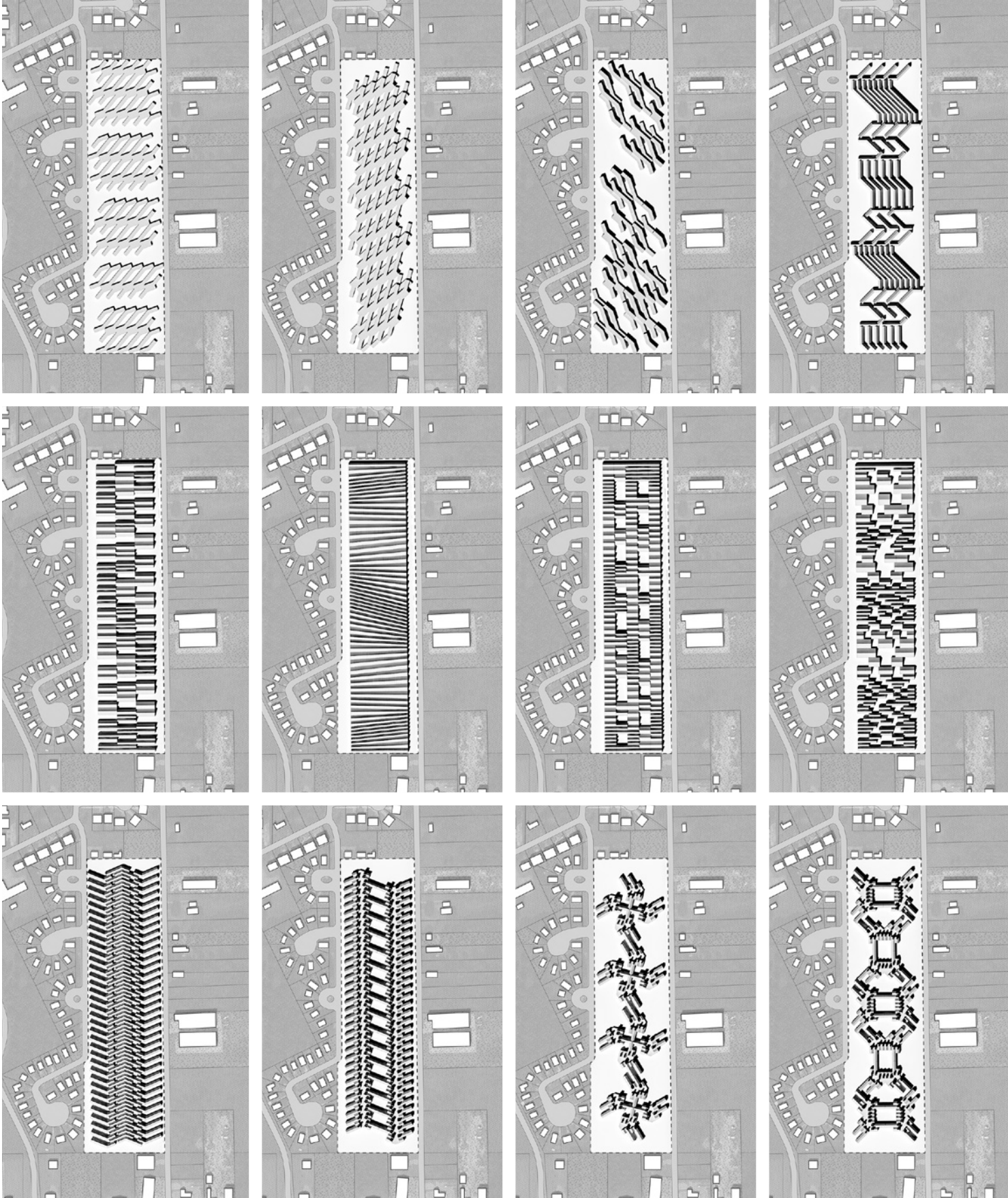

Store House

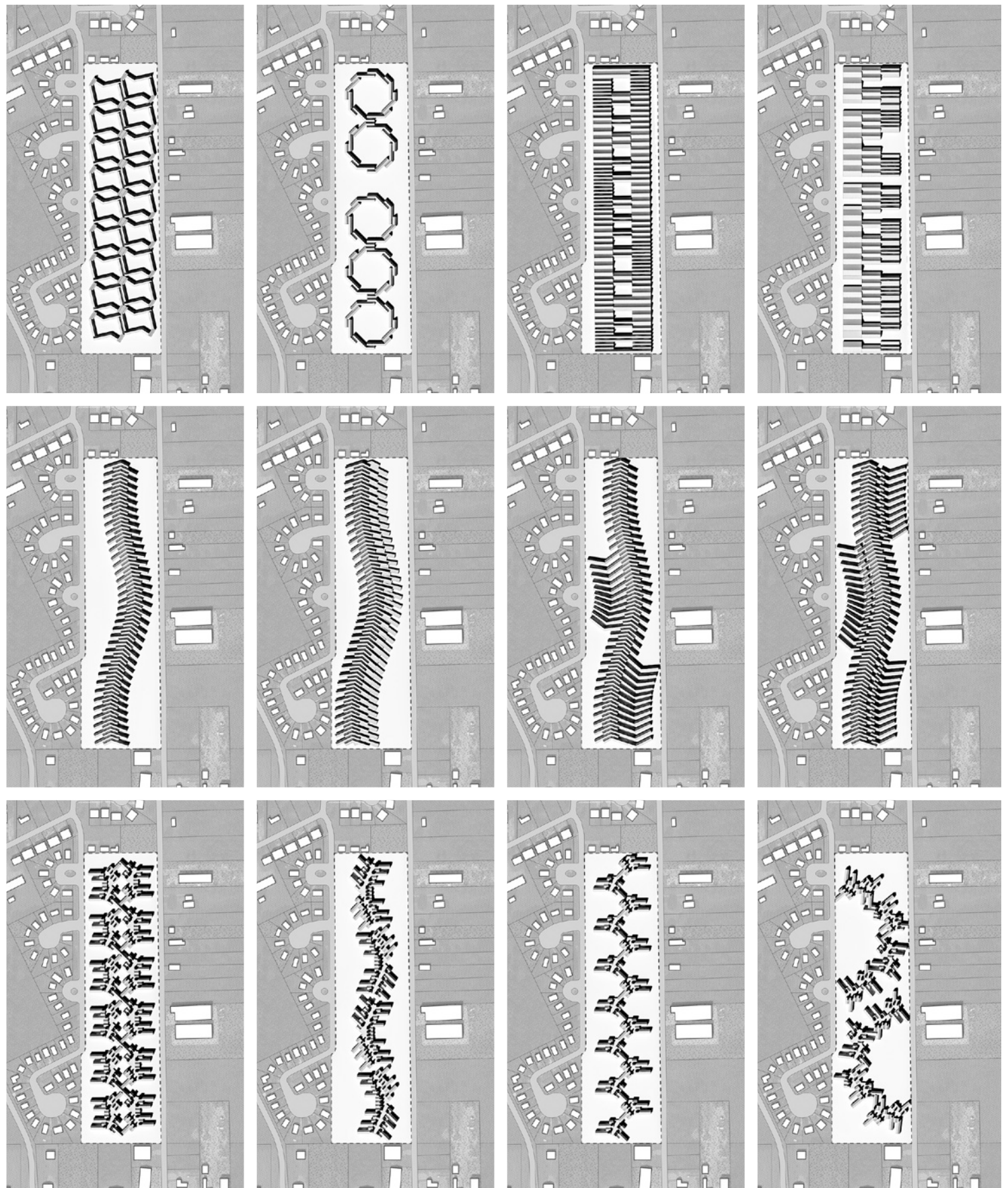

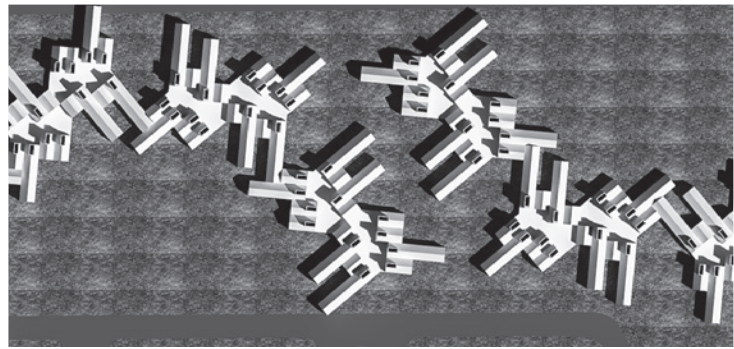
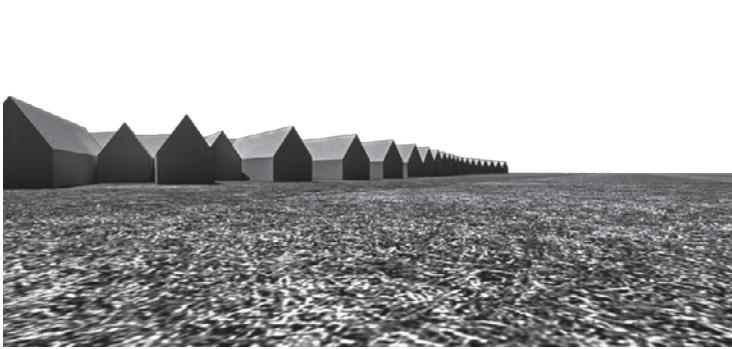
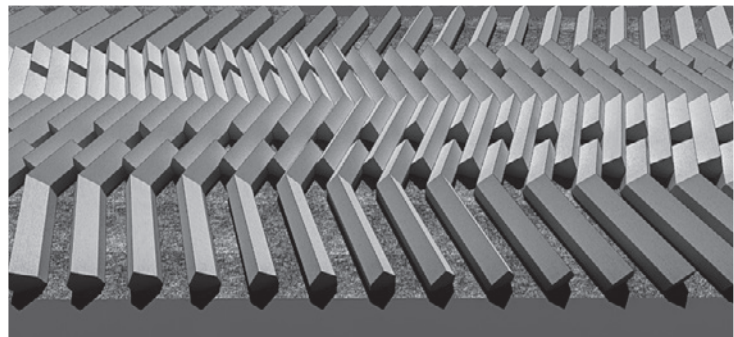
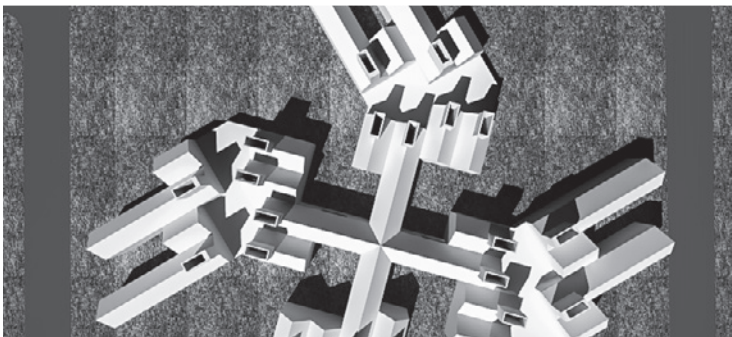
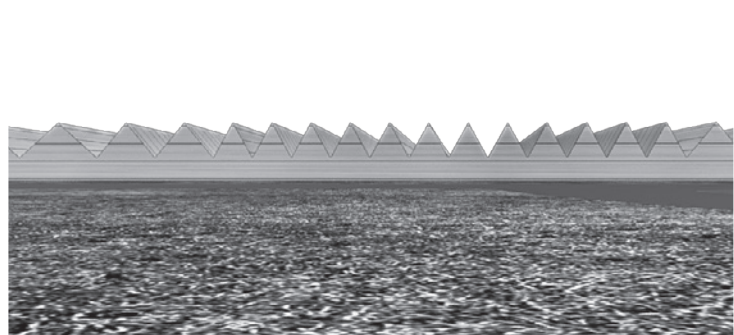
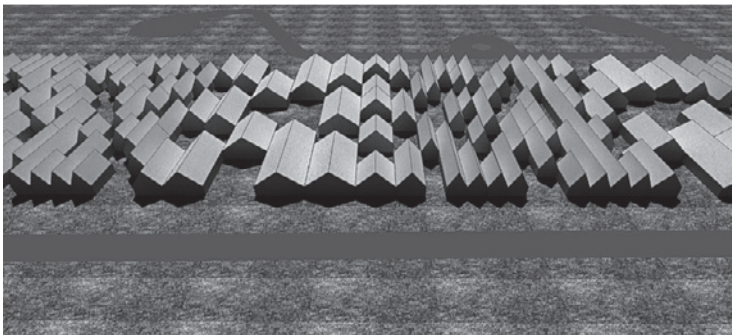
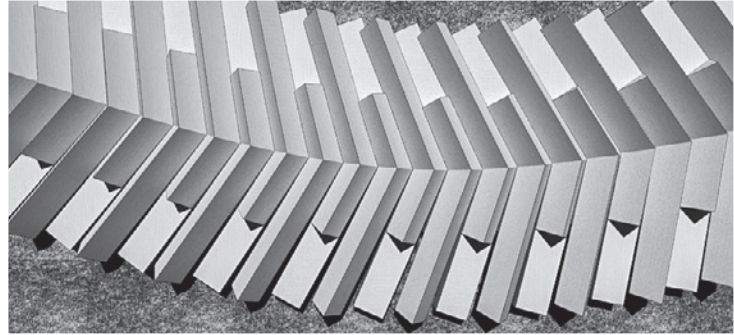
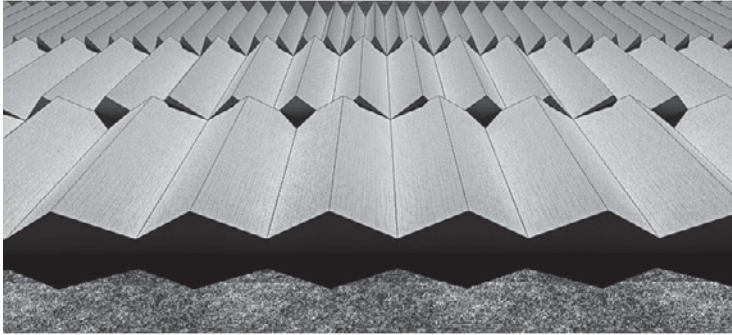
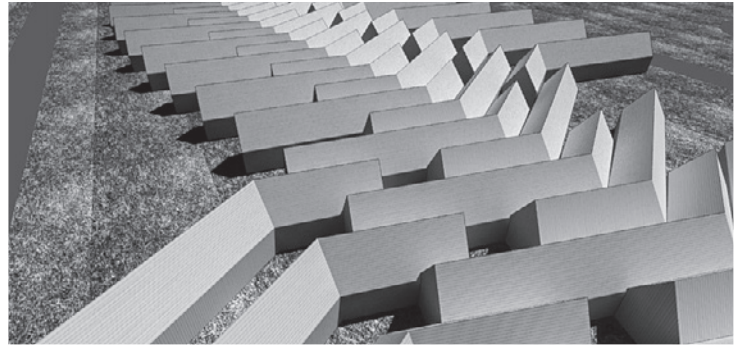
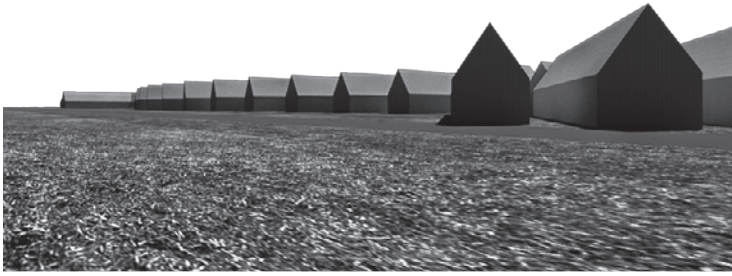

Store House

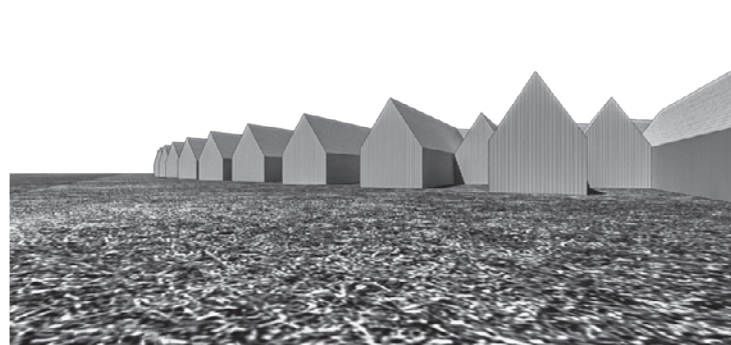
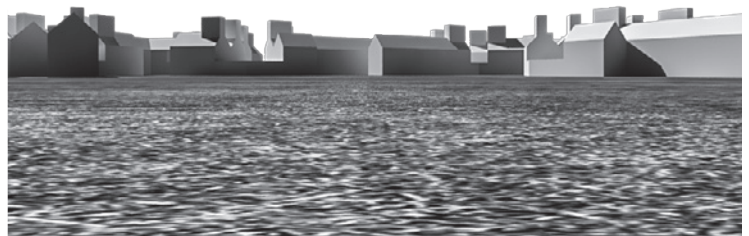
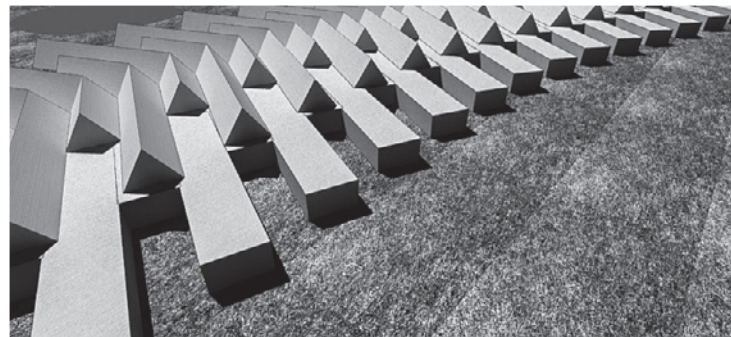
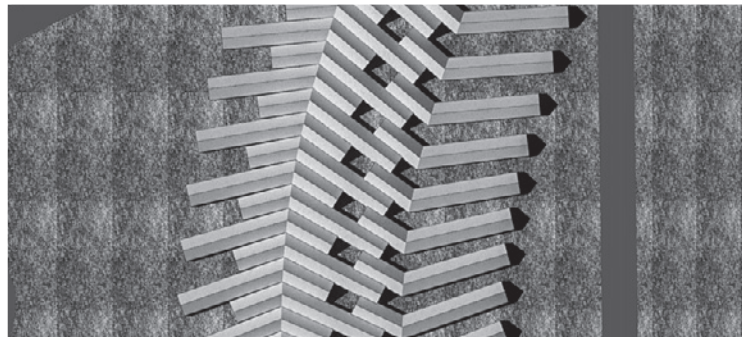
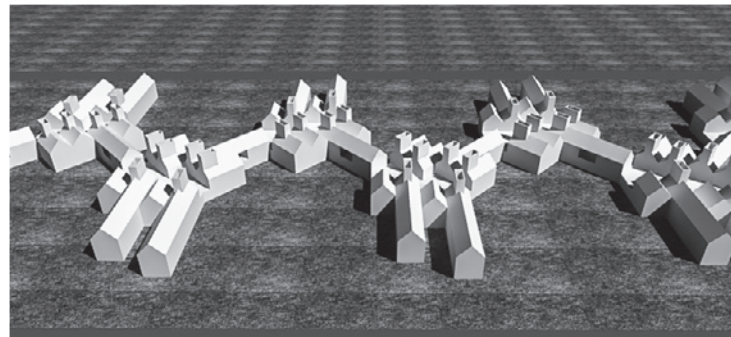
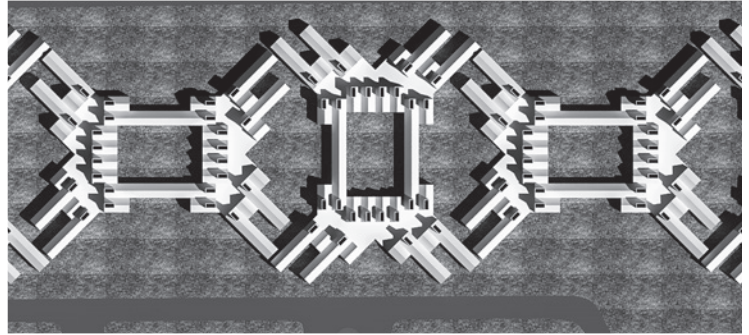
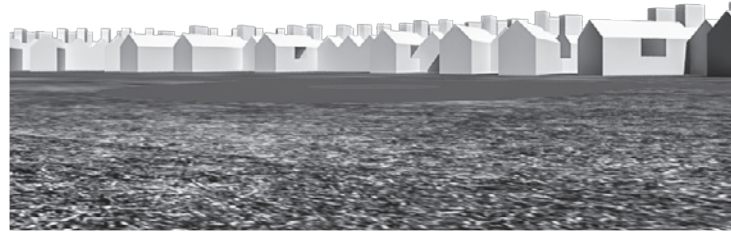
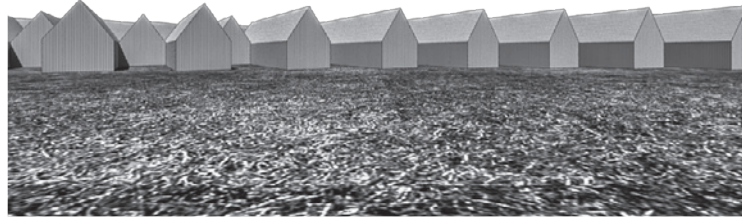

The Appendix

Image Tests

—
Testing different versions of the
project via image



Store House

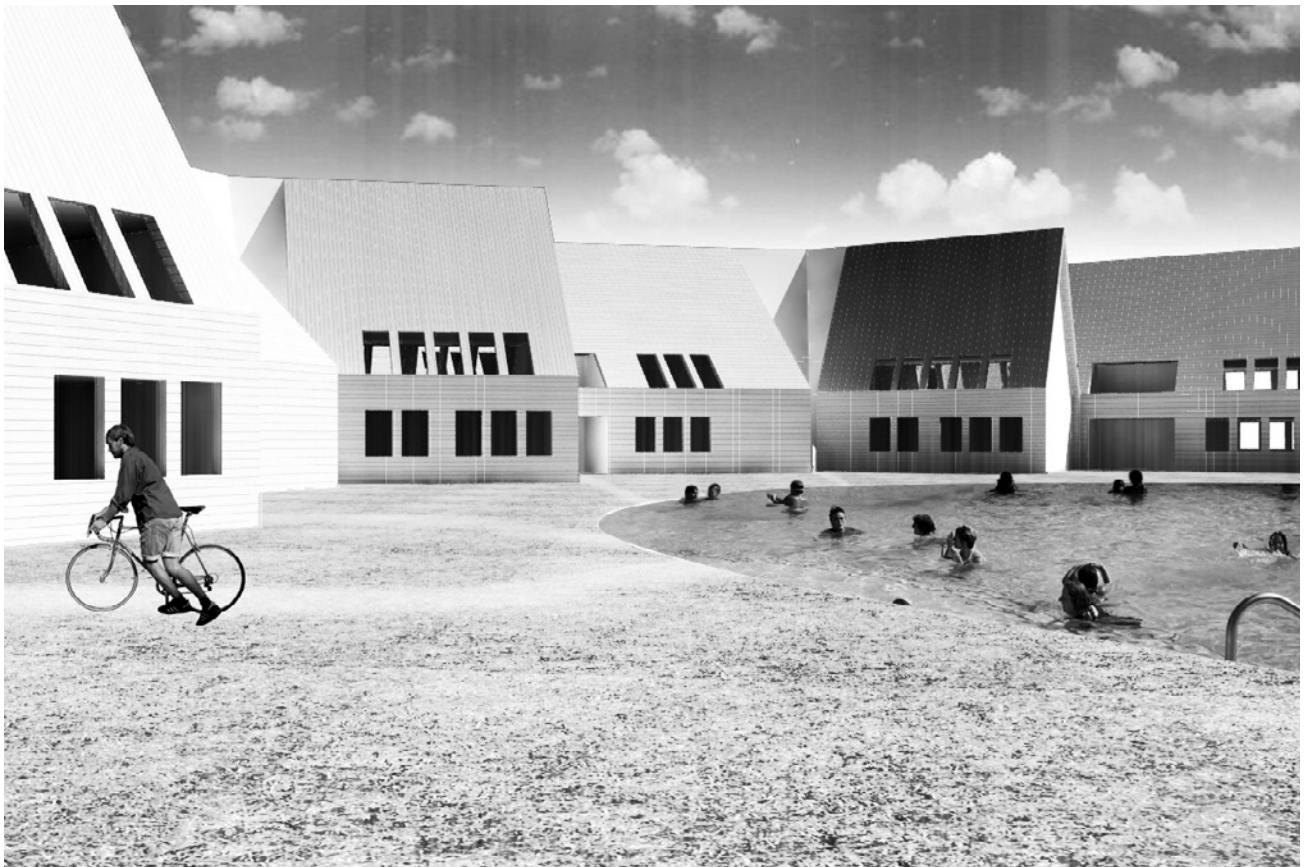

Massing Tests

—
This spread represents some of the massing options that were studied in concert with the plan and section studies of the final octet units.

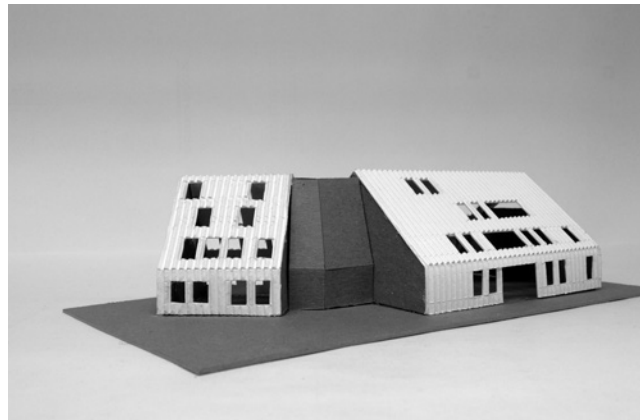
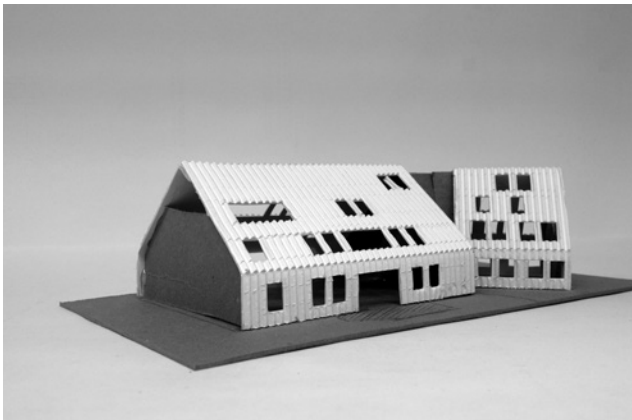
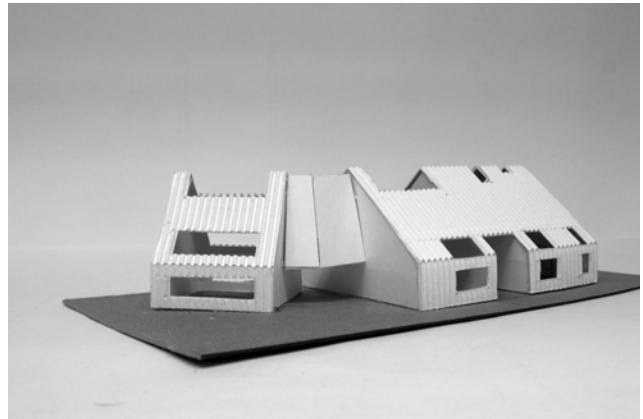
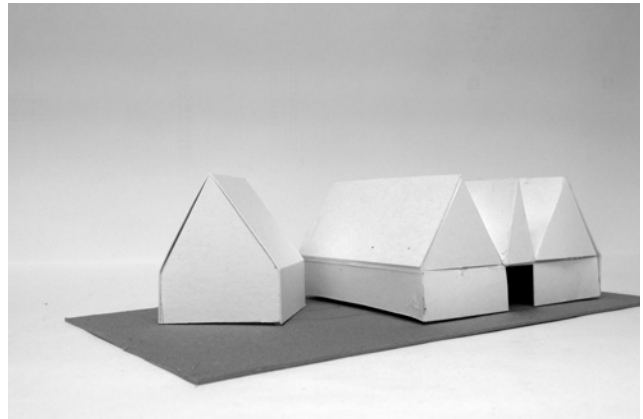

Store House

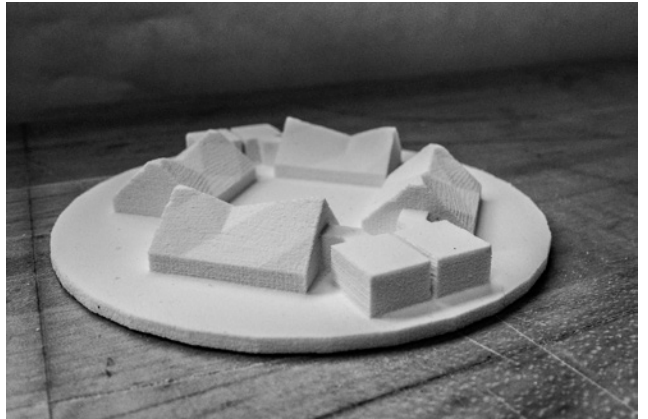
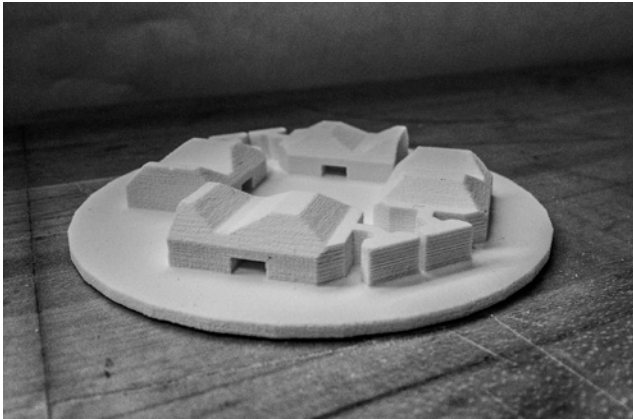
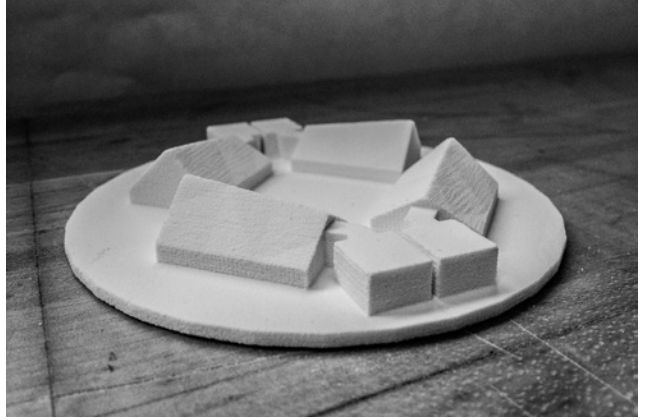
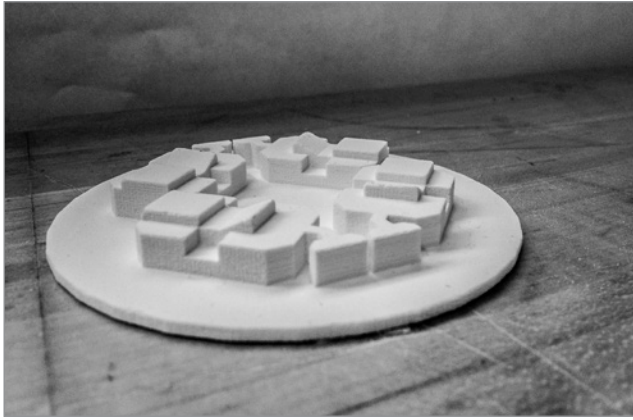
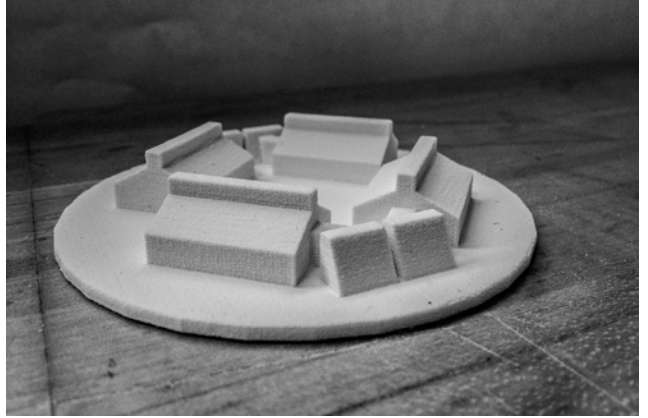

Excerpts from the Final Review

MIT Media Lab, Building E16
December 19, 2013. 4:00pm

Guest Critics

Paul Lewis, Ed Mitchell, Amanda
Reeser Lawrence, Lindy Roy

Committee

Ana Miljački, Cristina Parreño, Rafi Segal

Ed Mitchell: The big question is how does this relate to the city? If you live in Paris in a 600 square foot flat you have the whole city as your dining room, your pool, your street, your other stuff. Its not a place I would ever want to be in, but maybe its some people's choices. It reminds me of areas of New England just outside of cities, in kind of the decaying first ring of the suburbs.

Kyle Barker: For clarity, I'm not projecting this as a model for everyone. So it's not for you.

EM: It's a Texas model?

KB: Part of the appeal of the site was that it is a rectangle, so it can be transported in our minds as a typology. For me, Texas was useful in that it is a context that is densifying, has foreclosure problems, etc. But I'm not claiming that this project is the "Texan Sensibility." I don't feel qualified to make that claim.

...

EM: I'm not sure what the style of this is. *Melrose Place* had a modest sense of style? What is it that you're going for? Why do they look like ski rentals?

Lindy Roy: Well that comes from starting with the suburban house & scaling it up.

EM: But strip it of all of its ornament and all of the doo-dads that people actually like. They like those columns and all of that....How do you feel about that part of it?

KB: I think this is something that has come up a lot: "Are you saying you're replacing [the suburbs]?" I'm not saying that I'm replacing [them]. I'm saying that [my project] is an alternative to [them]. I'm starting with [conventional suburban homes], because right now we have the option of what you're saying—"The city is our place"—or the existing suburbs. And there doesn't seem to be much in between. I'm looking at what I see as an emerging subject and putting forward a proposal for that person.

...

EM: Don't you think that because you started with the initial thing of, "I really want it all but I can't afford the kitchen, and I can't afford this" that you're unsure what the new dream is? Like is it a cynical thing? We're going to start sharing cereal when food runs out?

KB: For me, I don't think about it as getting less than. It's a shift and you get different things. You have potential for interaction but in a way it could be a model of plenty. For example, I would never buy a fancy vacuum, but if I'm sharing it with four people then I might.

Amanda Reeser Lawrence: I do think there is a generational question here. You're identifying a "sharing generation." It's not about the sixties hippie commune. We all have embedded senses of what it means to create a community. You're trying to make this uncomfortable fit of a suburban dream with a more urban sensibility.

...

LR: The thing that was clearest to me is the shared work thing. To me that made sense. But does it become like a business center in a hotel or does it add up to something more? You set this thing in motion, people live in it incredibly successfully for five years, but does it change the way they do things?

KB: Just to put it out there, I am very optimistic. For me this isn't cynical, I'd say I'm probably too earnest about this.

LR: You'd like to live here?

KB: Yes, actually I would like to live here, but not in the suburbs because I'm too tied to the city. [Laughter] But the reason I think this is a relevant project is because I am not the majority. The majority of the US wants to live in the suburbs, and it's increasingly so. So I think if we care about cities and care about architecture I think we have to address the suburbs. I don't think its something that we can leave to *Toll Brothers*.

Paul Lewis: For me this is the most interesting thing about your project. Trying to take seriously the nature of the challenge of suburbia. And tying in foreclosure not just to a banking condition, but to actual architectural modifications.

...

PL: I think the very fact that you're tying in issues of mobile apps could be even more instrumental. The idea that you can control time in ways that is very different, and the spatial time of the domestic space can be even more polemically charged. So that, renting the dining room or anticipating the block party, so there are ways of organizing the spatial conditions through applications that could go to training the locks so that you may never even have to look at your neighbors.

...

PL: I'm just trying to think of how you might "re-app" your project so that you could, for example, claim the pool for three hours on a Saturday afternoon to produce the illusion that this is your private pool because everyone else's doors don't open. You have the small apartment but it looks like you've got the mega pool. Are you playing up the fantasy of the American Dream, now realizable on a much smaller scale?

Rafi Segal: I'm not sure that that is the objective of the project. And I don't think it should be. There is a different kind of future occupant that will understand living, or sharing, in a different way and this project introduces that person.

Photo by
Dave Miranowski



Bibliography

—

Collecting / Storage

Buzas, Stefan. *Sir John Soane's Museum*, London. Second ed. Tübingen: Wasmuth, 1997. Print.

Elsner, John. "A Collector's Model of Desire: The House and Museum of Sir John Soane." *The Cultures of Collecting*. Ed. John Elsner and Roger Cardinal. Cambridge, MA: Harvard UP, 1994. 154-76. Print.

Lavin, Sylvia. "Architecture in Extremis." *Log 22. The Absurd* (2011): 51-61. Print.

Sir John Soane's Museum - London UK. *Monumental Adventure*, 15 Jan. 2008. Web. 17 Apr. 2013.

Richardson, Margaret, and Mary Anne Stevens, eds. *John Soane, Architect: Master of Space and Light*. London: Royal Academy of Arts, 2000. Print.

Thornton, Peter, and Helen Dorey. *Sir John Soane: The Architect as Collector*. New York: Harry N Abrams, 1992. Print.

Housing Design

Arnold, Jeanne, Anthony Graesch, Enzo Ragazzini, and Elinor Ochs. *Life at Home in the Twenty-first Century: 32 Families Open Their Doors*. Los Angeles: Cotsen Institute of Archaeology, 2012. Print.

Ebner, Peter. *Typology+*. Basel u.a.: Birkhäuser, 2009. Print.

Fernández, Per Aurora. *10 Stories of Collective Housing: Graphical Analysis of Inspiring Masterpieces*. Vitoria-Gasteiz: A+T Architecture Publishers, 2013. Print.

Fernández, Per Aurora, and Javier Arpa. *Density Projects: 36 New Concepts on Collective Housing*. Vitoria-Gasteiz, Spain: A+T Ediciones, 2007. Print.

Fernández, Per Aurora, Javier Mozas, and Javier Arpa. *Dbook: Density, Data, Diagrams, Dwellings: A Visual Analysis of 64 Collective Housing Projects*. Vitoria-Gasteiz: A+T Ediciones, 2007. Print.

Gausa, Manuel, and Jaime Salazar. *Housing Singular Housing*. Barcelona: Actar, 2002. Print.

Heckmann, Oliver, and Friederike Schneider. *Floor Plan Manual Housing*. Basel: Birkhauser, 2011. Print.

Leupen, Bernard, Harald Mooij, and Rudy Uytenhaak. *Housing Design: A Manual*. Rotterdam: NAI, 2011. Print.

Housing History

Evans, Robin. "Figures, Doors and Passages." *Translations from Drawing to Building and Other Essays*. Cambridge, MA: MIT, 1997. 54-91. Print.

O'Briant, Alex. "Gray_Space: Investigations into the Domestic Closet." *Working 03: Design and Research 2001-02*. Ed. Luke Bulman and Jessica Young. Houston, TX: Rice School of Architecture, 2002. 156-95. Print.

Lasner, Matthew Gordon. *High Life: Condo Living in the Suburban Century*. New Haven: Yale UP, 2012. Print.

Housing Policy / Regulation

Bratt, Rachel, Michael E Stone, and Chester W. Hartman. *A Right to Housing: Foundation for a New Social Agenda*. Philadelphia, PA: Temple UP, 2006. Print.

Schwartz, Alex F. *Housing Policy in the United States*. New York: Routledge, 2010. Print.

United States. City of Tomball, Texas. Office of Land Use & Zoning. *Zoning Ordinance No. 2008-01*. Print.

Poche

Grunenberg, Christoph, and Sheila Kennedy. *Material Misuse: Kennedy & Violich Architecture*. London: Architectural Association, 2000. Print.

Meisenheimer, Wolfgang. "Of the Hollow Spaces in the Skin of the Architectural Body." *Daidalos* 13 (1984): 103-11. Print.

Precedent Research

Ferrer Fores, Jaime J. "Mat Urbanism: Growth and Change." *Projections: Designing for Growth & Change* 10 (n.d.): 73-83. Print.

Maas, Winy, Jacob Van Rijs, and Richard Koek. *FARMAX: Excursions on Density*. Rotterdam: 010, 1998. Print.

Sarkis, Hashim. *Case: Le Corbusier's Venice Hospital*. Munich: Prestel, 2002. Print.

Smithson, Alison, Peter Smithson, and Beatriz Colomina. Alison and Peter Smithson: *From the House of the Future to a House of Today*. Ed. Dirk Van Den Heuvel and Max Risselada. Rotterdam: 010, 2004. Print.

Sharing

Monu: Communal Urbanism 18 (2013): Entire Issue. Print.

Yoon, J. Meejin, and Eric Howeler. *Shareway*. Audi Urban Future Initiative, n.d. Web. Feb. 2013.

-topia

Djalali, Amir. "20th Century's Utopian Architecture." *Volume: Engineering Society*. 16 (2008): 56-67. Print.

Foucault, Michel. "Of Other Spaces, Heterotopias." *Architecture/Mouvement/Continuité* October (1984): n. pag. Print.

Heynen, Hilde. "The Need for Utopian Thinking in Architecture." *Hunch* 6/7 (2003): 241-43. Print.

Van Den Heuvel, Dirk. "To Imagine (an Image Of) a World of Images: The Dream Houses of Andreas Angelidakis." *Volume: Interiors*. 33. 2012: 106-10. Print.

The Suburbs

De Ru, Nanne. "Hollocore." *Content*. Ed. Rem Koolhaas. Köln: Taschen, 2004. 336-49. Print.

Bergdoll, Barry, and Reinhold Martin. *Foreclosed: Rehousing the American Dream*. New York: Museum of Modern Art, 2012. Print.

Hayden, Dolores. *Building Suburbia*. New York: Pantheon, 2003. Print.

Hayden, Dolores, and Jim Wark. *A Field Guide to Sprawl*. New York: W.W. Norton, 2004. Print.

Martin, Reinhold, Leah Meisterlin, and Anna Kenoff. *The Buell Hypothesis: Rehousing the American Dream*. The Temple Hoyne Buell Center for the Study of American Architecture. 2011. Web. 5 Feb. 2013.

Pope, Albert. *Ladders*. Houston, TX: Rice School of Architecture, 1996. Print.

Quint, Rose. "What Home Buyers Really Want." *Housing Economics*. NAHB, 1 May 2013. Web.

Thun, Geoffrey, Kathy Velikov, and Colin Ripley. "Re-Centering the Periphery." *Volume: Centers Adrift*. 32 (2012): 30-37. Print.

Williams, Alex. "Creating Hipsturbia." *The New York Times*. 15 Feb. 2013. Web. 1 May 2013.

Next Page: The gables from the ten best-selling homes in the United States, arranged chromatically.

