

FORM FOLLOWS FLOW

RE-IMAGINING THE SKYSCRAPER

BY JUNEY LEE

Bachelor of Arts, Architecture (2007)
University of California, Berkeley

Submitted to the Department of Architecture, February 2014
in Partial Fulfillment of the Requirements for the Degree of
Master of Architecture at the Massachusetts Institute of Technology

Copyright 2014 Juney Lee. All Rights Reserved.
The author hereby grants to MIT permission to reproduce and to distribute publicly
paper and electronic copies of this thesis document in whole or in part
in any medium now known or hereafter created.

Signature of Author _____
Juney Lee
Department of Architecture
January 16th, 2014

Certified by _____
Nader Tehrani
Professor of Architecture
Thesis Supervisor

Accepted by _____
Takehiko Nagakura
Associate Professor of Design and Computation
Chair of the Department Committee on Graduate Students

THESIS COMMITTEE

ADVISOR

Nader Tehrani
Professor of Architecture

READERS

John Ochsendorf
Professor of Building Technology and Civil and Environmental Engineering

Paul Kassabian
Lecturer of Civil and Environmental Engineering

FORM FOLLOWS FLOW

RE-IMAGINING THE SKYSCRAPER

BY JUNEY LEE

Submitted to the Department of Architecture, February 2014
in Partial Fulfillment of the Requirements for the Degree of
Master of Architecture at the Massachusetts Institute of Technology

ABSTRACT

Skyscraper is a by-product of 19th century American industrialism, spirit, and disaster. The Great Chicago Fire of 1871 was a catastrophe that necessitated dense and rapid reconstruction, both of which the high-rise provided. The accidental discovery of this new typology forever changed the contemporary urban habitat.

Demand required density, which produced profit. Relentless pursuit of maximum mass and profit in 20th century New York City transformed the skyscraper into shameless public display of cash cows for the elite few of the capitalist society. Enslaved by its financial incentives, the promise it once held was negated by repetitive banality.

Today, architects are desperately prolonging the life of a typology that has not been invested with new thinking or ambition since its inception (Koolhaas, 2004). The intensification of density it initially delivered has been replaced by carefully-spaced isolation to maximize its visual superiority. Skylines of emerging civilizations have become test sites for celebrity architects to display their brands which are more interested in its private agenda than greater public good.

By 2050, 70% of the world's population will be living in urban areas

(United Nations, n.d.). In 2012 alone, 66 buildings taller than 200 meters were constructed worldwide (CTBUH, 2013). In an age when explosive growth is not imminent, but inevitable, the developing societies continue to "adopt the skyscraper as the symbol of its modernity" (Koolhaas, 2004). Skyscraper is a critical architectural specimen that will not only symbolize that growth, but also accommodate and sustain it.

The typology was born out of necessity, pushed to the limits through its financial objectives, and is now polluted with vanity of celebrity architecture. The objective of this thesis is not to design the "perfect" skyscraper. Rather, it challenges the century-old methods of envisioning and designing skyscrapers in order to resurrect its urban significance.

The typology must be re-imagined in its totality through the fundamental understanding and re-investigation of the flow of elements that make the skyscraper possible.

Thesis Supervisor : Nader Tehrani
Title : Professor of Architecture

INTENTIONALLY LEFT BLANK

1

HISTORY & EVOLUTION OF THE SKYSCRAPER



Fig. 1 Scene of downtown Chicago, after the Great Fire of Chicago in 1871.

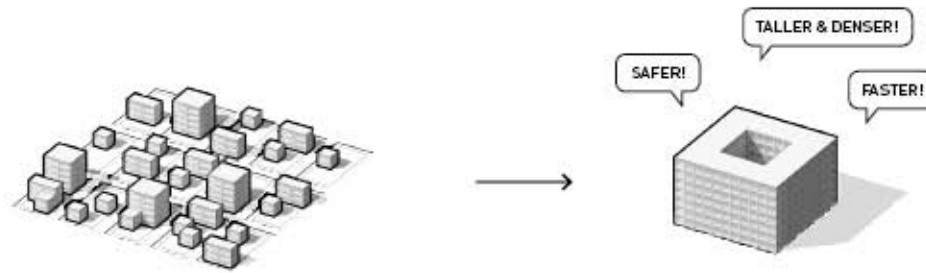

BIRTH OF THE TYPOLOGY: **FORM FOLLOWS FUNCTION**

The Great Chicago Fire of 1871 destroys 3.3 square miles of Chicago. A new building typology with higher density, and faster construction was needed.

At the end of the 19th century, Chicago was one of the most prosperous cities of the United States. Located between the unknown West and the civilized East, Chicago played an important role economically and politically.

The rapidly growing city was struck with a colossal disaster in 1871, when a fire broke

out which ended up destroying nearly 3.3 square miles of downtown Chicago (Bale, 2004). The prosperity came to an abrupt halt, with much of its buildings gone with thousands of its citizens abandoned on the street. The city had to rebuild itself from scratch. Quickly to meet the immediate demands, and efficiently to fulfill the capacity.

A new building typology had to be invented, in order to build denser and faster, while providing safer habitats for people in order to prevent any destruction from future fires. To meet these functional demands, the high-rise typology was born.

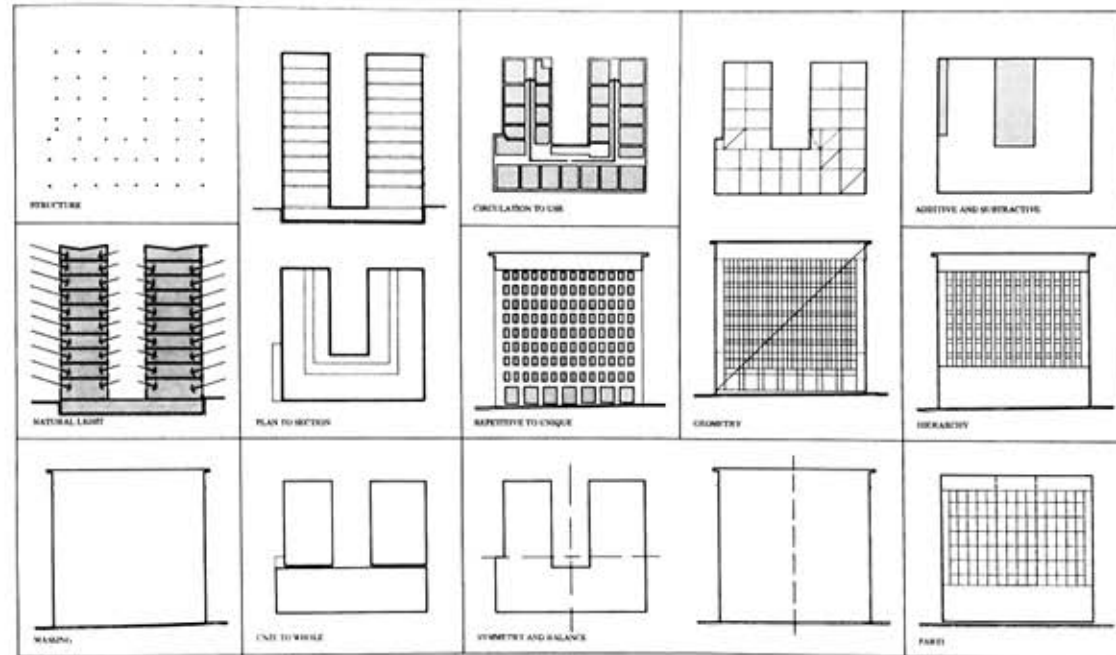

Fig. 2 Wainwright Building Diagrams, Louis Sullivan (1891)

“It is the pervading law of all things organic and inorganic, of all things physical and metaphysical, of all things human and all things superhuman, of all true manifestations of the head, of the heart, of the soul, that life is recognizable in its expression that... FORM EVER FOLLOWS FUNCTION. This is the law.”

- LOUIS SULLIVAN, from “The Tall Office Building Artistically Considered” (1896)

Need for rapid recovery from the fire was the cause of demand for density. To construct buildings taller and faster than ever before, new materials and techniques were necessary. Mechanized elevator was invented and steel was commercialized, and gave birth to the new, high-rise typology.



Fig. 3 Home Insurance (1884), Chicago
by William Le Baron Jenney



Fig. 4 Wainwright Building, (1891), St. Louis
by Adler & Sullivan



Fig. 5 Reliance Building (1894), Chicago
by John Root, Charles B. Atwood



Fig. 6 View of midtown New York during the early 1900s.

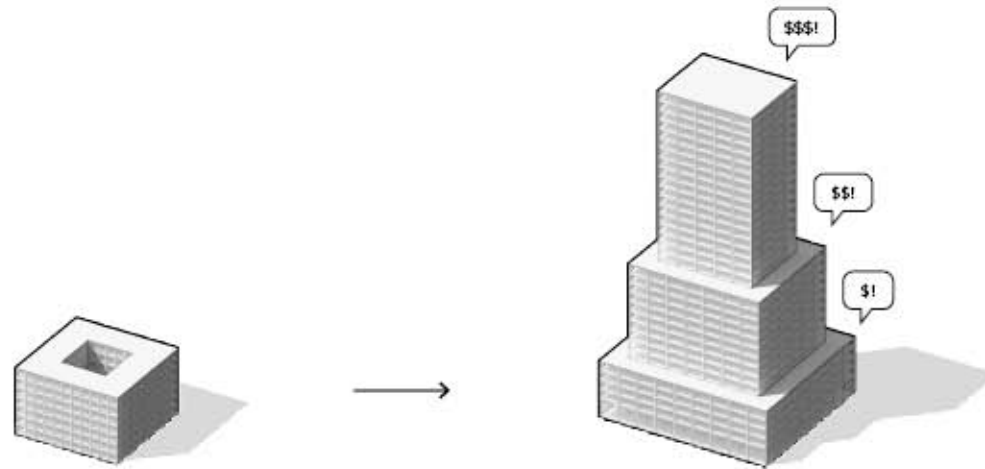

EVOLUTION OF THE TYPOLOGY: FORM FOLLOWS FINANCE

Demand required density, which produced profit. In New York, the typology was pushed to new limits with increasing financial incentives.

The steel frame office typology was adapted by New York, where it underwent an explosive growth and evolution. In Manhattan where plots were small and tight, buildings rose as high as the construction materials were able to withstand. With every site and its owner attempting to max out its buildable air rights, the city experienced an urban

phenomena where the street realm was becoming engulfed by the forest of extruded boxes, depriving it of any daylight or life.

The Zoning Ordinance of 1916 prevented buildings from becoming too box-y and too bulky, and implemented strict zoning envelopes that forced buildings to step back in elevation at upper levels, so that daylight

would reach the street levels. This resulted in skyscraper forms that were terraced and variations of stepped-pyramids. Regardless of the site conditions or zoning regulations, the point of the 20th century skyscraper was to build as much as possible, and as high as possible within the boundaries to provide the highest possible profit.

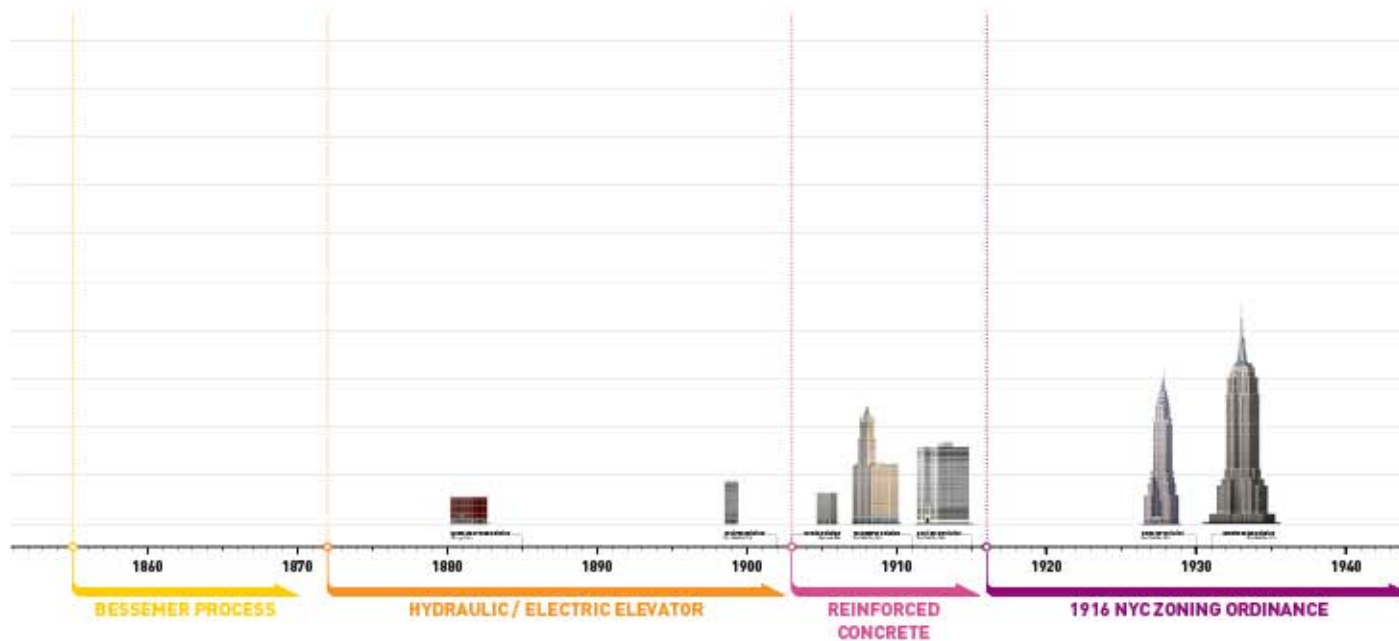

Driven by financial incentives, various innovations enabled taller buildings that generated more revenue.

BESSEMER PROCESS

Methods of rapidly producing steel, known as the Bessemer Process, enabled steel framed building to built much more cheaply.

HYDRAULIC /ELECTRIC ELEVATOR

Instead of using steam like in Elisha Otis's original elevator invention, introduction of the hydraulic and electric elevator makes buildings the elevators much easier to install, carry more weight and above all, much more reliable. buildings taller than six stories much more practical and habitable.

REINFORCED CONCRETE

While steel frame achieves greater heights with far less material, its lightness and slenderness requires large masses in its foundation that can distribute the load evenly into the grade below the building's foundation. Commercialization of concrete and its growing use in the construction sector, allowed the introduction of concrete buildings and foundation designs that strengthened the steel framed buildings.

1916 NYC ZONING ORDINANCE

Park Row building was completed in 1899, and triggered the city to react to these tall

buildings that were straight extrusions which began to make the building look bulky and cast shadow at the public street level for long periods of time during the day. The New York City Zoning Ordinance of 1916 restricted the building from becoming straight extrusions from its base to the top. Series of setback regulations at different elevations were implemented, which is what made most of the buildings in New York look like how they are today with stepped masses and forms. The two supertall buildings built during this period, the Chrysler Building and the Empire State Building, are good examples of direct consequence of this ordinance.

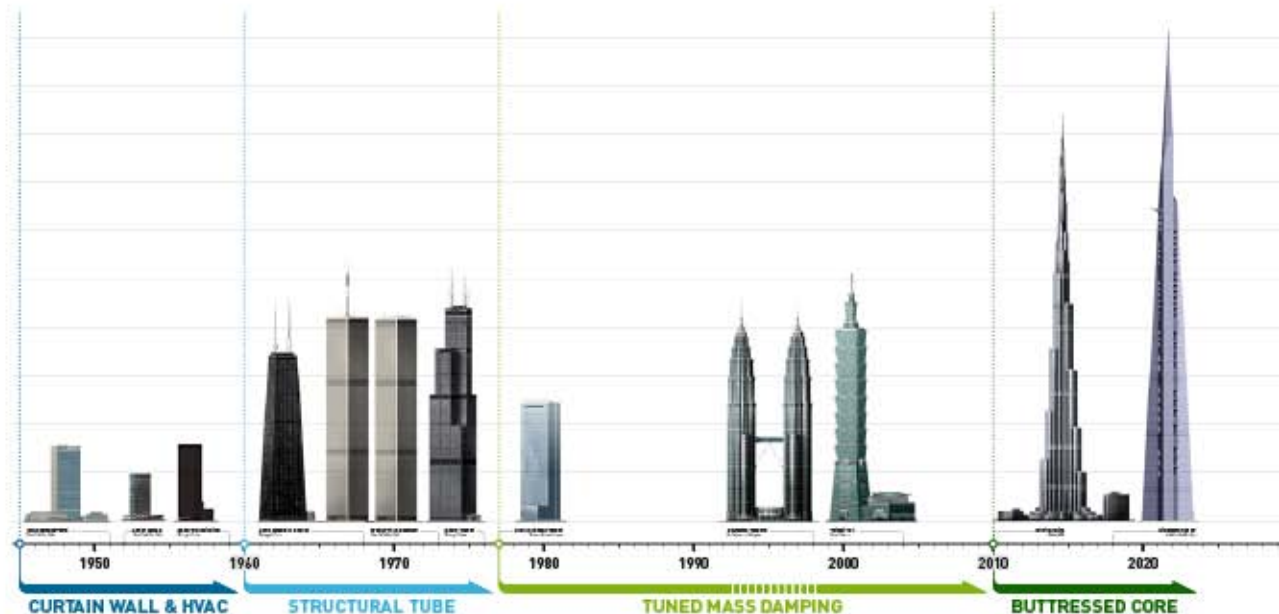

Unprecedented heights were achieved, and the modern skyscraper was constructed all over the world.

CURTAIN WALL & HVAC

Invention of the curtain wall facade system allowed increased amount of glass usage, which in result allowed more natural lighting and general views out from the building. But improved lighting and views came at the cost of solar heat gain through the windows, which forced commercialization of MEP and AC systems in building industry.

STRUCTURAL TUBE

Structural engineer Fazlur Kahn introduced the idea of exo-skeleton structure, which puts all of the buildings' main vertical and lateral structural system to the perimeter of the

building. These structural "tubes" were able to drastically reduce weight, while increasing the height capacity.

TUNED MASS DAMPING

Structural tubes proved to be light and strong, but too elastic and flexible which made the top of the building sway too much. This caused undesirable comfort levels for the occupants near the top floors. To help the building resist the swaying motion as much as possible, heavy weight or damper is placed near the top of the building, to add a bit more inertia.

BUTTRESSED CORE

Putting dampers that are not only big, but take up valuable real estate at the top of the skyscraper is counter productive, and an inefficient way of using the top prime levels of the building. Idea of the buttressed core by William Baker of SOM strengthens the core from the bottom up and inside out, drastically increases the strength of the core and the building, while keeping the perimeters clear from big structural members.



Fig. 7
Home Insurance Building
(1884), Chicago

by CASS GILBERT



Fig. 8
Barclay-Vesey Building
(1927), Chicago

by RALPH WALKER



Fig. 9
Empire State Building
(1931), New York

SHREVE, LAMB &
HARMON



Fig. 10
Chrysler Building (1930),
New York

by WILLIAM VAN ALEN



Fig. 11
Rockefeller Center
(1939), New York

by RAYMOND HOOD



Fig. 12
Raymond Hood



Fig. 13
Robert Moses

During the early 1900s, architects and developers of New York built skyscrapers to its maximum physical capacity. With the construction technologies available at the time, they pursued whatever means necessary to build to the maximum extents that the municipal zoning envelopes allowed.

During the later half of the century, new materials, breakthrough engineering and rapidly advancing construction industry allowed skyscrapers to be built faster, lighter and taller. Skyscraper becomes adapted as the symbol of growth and prosperity all over the world.



Fig. 19
M. van der Rohe



Fig. 20
Fazlur Khan



Fig. 21
Bruce Graham



Fig. 14
Seagram Building (1958),
New York

by LUDWIG MIES van der
ROHE



Fig. 15
Lever House (1951), New
York

by SKIDMORE OWINGS &
MERRILL LLP



Fig. 16
John Hancock
Center(1965), Chicago

by SKIDMORE OWINGS &
MERRILL LLP



Fig. 17
World Trade Center
(1970), New York

by MINORU YAMASAKI +
EMERY ROTH & SONS



Fig. 18
Willis Tower (1973),
Chicago

by SKIDMORE OWINGS &
MERRILL LLP

As skyscrapers become more predominantly driven by financial incentives, its architectural exploration and urban consequences become less important for clients. Straight extrusions are indeed the most profitable mass a site can produce.

Decades of investment has been made by the construction industry to find newer ways to build taller skyscrapers in shorter amount of time. What was once considered feats of engineering and technology, has become an architectural commodity that is easily constructed and repeated anywhere in the world.

“The skyscraper has become less interesting in inverse proportion to its success. It has not been refined, but corrupted; the promise it once held... has been negated by REPETITIVE BANALITY.”

- Rem Koolhaas (“Content” 2004)



Fig. 22 New York City, USA



Fig. 23 Hong Kong, China



Fig. 24 Shenzhen, China



Fig. 25 Seoul, Korea



Fig. 26 Sao Paulo, Brazil



Fig. 27 Chicago, USA



Fig. 28 View of Burj Khalifa in Dubai, United Arab Emirates.

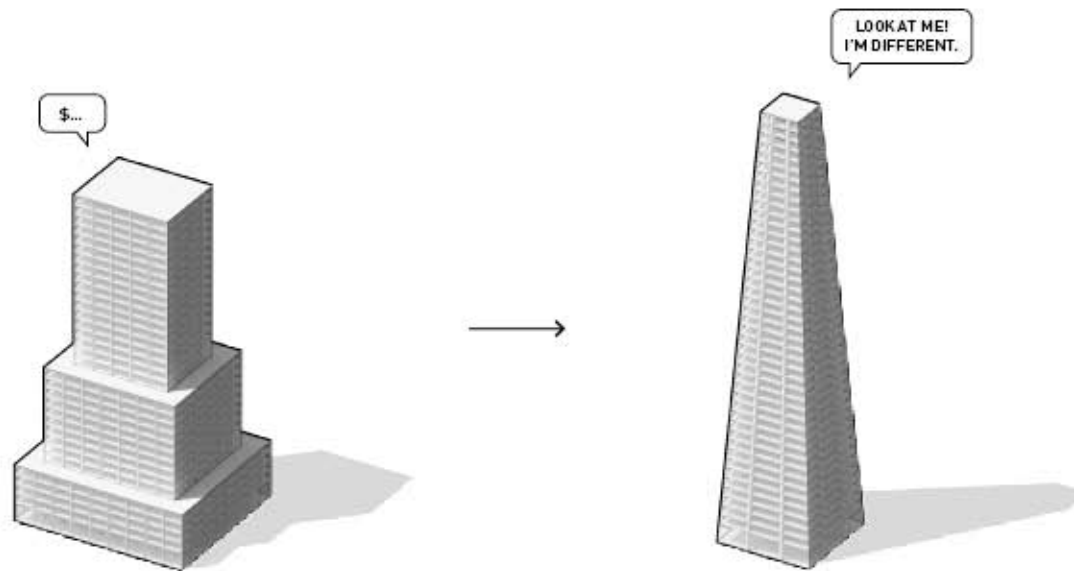

THE TYPOLOGY TODAY: FORM FOLLOWS FAME

More than just a provider of density or profit, skyscrapers become urban monuments, distinguishing itself from a sea of extruded boxes.

By the turn of the 20th century, skylines around the developed countries became filled with sea of unrecognizable skyscrapers. Such urban landscape is a direct result of the capitalist society. While these high-rises may have provided with the real estate market with plenty of revenues,

its complete disregard for its visual impact on its context became a new stimulant for a new type of skyscraper: the "urban monument."

As skyscrapers with visual distinction from the mundane norm began to define

the famous skylines, its iconic presence and fame became the new priority for the clients. In today's skyscraper landscape, what client would want to be known for the "extruded box"? Whether it is unusual form, or overwhelming height, this generation of skyscrapers seek for the global fame.

Today, starchitects are desperately prolonging the life of a typology that has not been invested with new thinking or ambition since its inception (Koolhaas, 2004).

The Google logo is centered on the page, rendered in its characteristic multi-colored font.A screenshot of a Google search interface. The search bar contains the text "skyscraper (any starchitect name here)". Below the search bar, a list of search suggestions is displayed, each starting with "skyscraper" followed by a famous architect's name: "rem koolhaas", "zaha hadid", "bjarke ingles group", "jean nouvel", "UN studio", "herzog & de meuron", "toyo ito", "MVRDV", "SANAA", and "diller scofido renfro". A microphone icon is visible in the top right corner of the search bar area.

Skyscrapers of emerging civilizations have become test sites for celebrity architects to display their brands which are more interested in its private agenda than greater public good.



Fig. 30
Thompson, Ventulett,
Stainback & Associates

The Lagoons Towers
[Unbuilt] -Dubai, UAE



Fig. 31
OMA

Cctv (2012) -Beijing, China



Fig. 32
Zaha Hadid Architects

Dubai Signature Towers
[Unbuilt]- Dubai, UAE



Fig. 33
MVRDV

The Cloud [Unbuilt] - Seoul,
Korea



Fig. 34
BIG

Ren Building [Unbuilt] -
Shanghai, China



Fig. 35
Zaha Hadid Architects

One Thousand Museum
Tower [Unbuilt] - Miami,
USA



Fig. 36
WS Atkins & Partners

Trump International Hotel
And Tower [Unbuilt] - Dubai,
UAE



Fig. 37
BIG

Walter Towers [Unbuilt] -
Prague, Czech Republic



Fig. 38
Gehry Partners

King Street Towers [Unbuilt]
- Toronto, Canada



Fig. 39
OMA

Singapore Towers [Unbuilt]
- Singapore

Meanwhile, corporate architecture has taken **height as its motive**,
to rise above the competition to distinguish itself as the “tallest in the world.”



Fig. 40
Shanghai Finance Center
(2008), Shanghai
by Kohn Pederson & Fox



Fig. 41
Petronas Towers (1998), Kuala
Lumpur
by Ceasar Pelli



Fig. 42
Taipei 101 (2004), Taipei
by C.Y. Lee & Partners



Fig. 43
Burj Khalifa (2010), Dubai
by Skidmore Owings & Merrill



Fig. 44
Kingdom Tower (2019),
Jeddah
by Adrian Smith + Gordon Gill

Skyscrapers become monuments and trophies, more interested in its ultimate bragging rights
than contextual or urban significance.

**“Vanity height” is defined as
the distance between a skyscraper’s highest occupiable floor and its architectural top.**

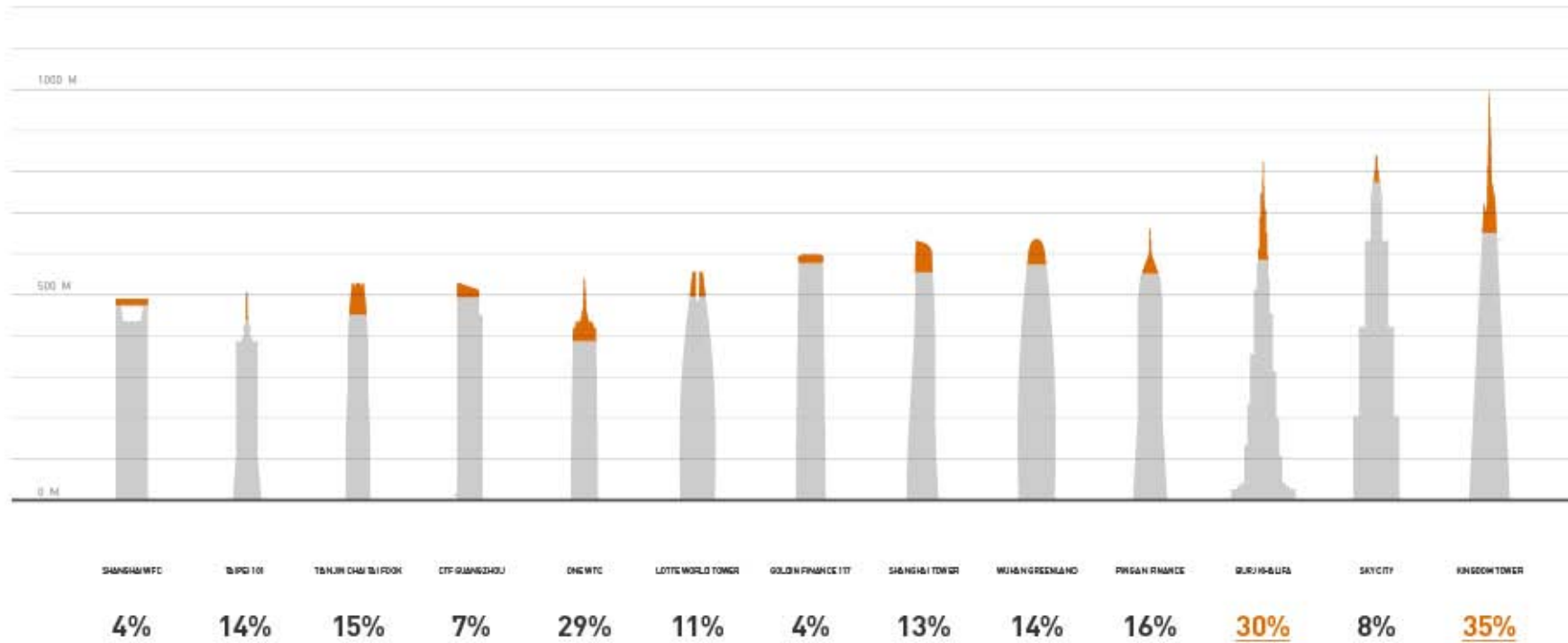

Fig. 45 Diagram showing the “vanity height” of the tallest 13 building by year 2020.

**Of the currently the tallest tower and the tallest tower that is under construction,
nearly a third of its height is a decorative, architectural spire that is not functionally usable or occupiable.**

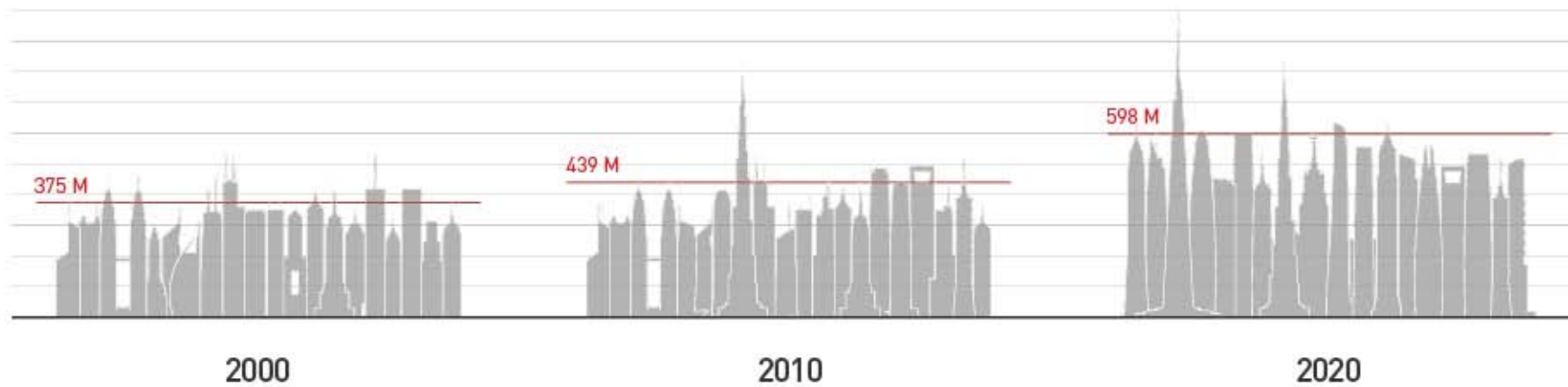

Fig. 47 Diagram showing the average height of the twenty tallest buildings in the world by decades. [CTBUH, 2013]

**Responsibly or not, taller and taller skyscrapers continue to be constructed all over the world.
The rate of construction is also increasing exponentially each decade.**

In 1906, not shortly after the birth of the American skyscraper in Chicago, landscape architect H. A. Caparn called the new building type “a revolt against the laws of nature and economics.” He claimed that the only rationalization for buildings so tall was revenue and ego. Looking at today’s trend of tall building around the world, maybe it is no coincidence that the majority of the most recent supertalls are highly concentrated in the Middle East and China. They respond to artificial climate more so than natural, and are “stark and concrete expression of tyranny and ruthlessness of modern business.” [H.A. Caparn 1906]

On the contrary, rather than a revolt against the laws of economics, supertalls can be considered to be very expressions of it. Unlike the pyramids of ancient Egypt, Versailles of France or Parthenon of Greece, the supertall phenomena in Shanghai and Dubai are direct result of the market, and not an obsessive pursuit of single monarch or a man. While they are the monuments and icons of modern cities, they are also a direct reflection of the capitalist world and climate we live in today.

Aside from the economic motives, growing urban population is the fundamental reason

for the necessity of supertalls. By 2008, more than half of the world’s population was living in urban areas. By 2030, this number is expected to rise to almost 5 billion, which is equivalent to average growth of 1.7 million people per year. [Grimond 2007] As urban areas get crowded and available real estate becomes scarce, buildings inevitably keep getting taller and denser to accommodate the demand.

Construction of skyscrapers continue to increase every year, and their height also get higher and higher. It is projected, that the twenty tallest buildings in 2020 will have

an average height of near 600 meters. Until two years before the completion of the Burj Khalifa, such type of high-rise building did not exist. The term “supertall,” which is used to describe buildings taller than 300 meters, is no longer the standard or an adequate enough term to describe these buildings.

At the start of the 21st century, the Petronas Towers in Kuala Lumpur was the world’s tallest building at 452 meters (1,483 feet) in height. Taipei 101 took the title in 2004, at 508 meters (1,667 feet). Then, in 2010, the Burj Khalifa set new record at 828 meters

(2,717 feet) – over half a mile high. Now, with work set to start on-site in January 2012 for Jeddah’s 1,000+ meter Kingdom Tower by Adrian Smith & Gordon Gill Architecture, the height of the “World’s Tallest Building” will have more than doubled in just over two decades. (Hollister 2011)

Building taller than ever before is an extraordinary engineering feat, but the only criteria that receives any attention for a skyscraper is its height. “World’s Tallest” building no longer has the awe or mystique that it once used to, because such tall

buildings are much easier to build at a fast rate. These tallest of the tallest buildings are measured against one another by its height for the ultimate bragging rights. Buildings over 600 meters tall require tremendous amount of investment energy to realize, and that much more to keep it functioning after its completion. Rather than reaching for the “World’s Tallest Building” title, Megatall typology must be critiqued, and re-imagined for design potentials that are often overlooked over financial incentives.

Rather than reaching for the “world’s tallest building” title, the skyscraper as a typology must be critiqued, and re-imagined for design potentials that are often overlooked over financial incentives.

INTENTIONALLY LEFT BLANK

2

THESIS STATEMENT & RESEARCH

Rather than reaching for the “world’s most _____ skyscraper” title, the skyscraper as a typology must be critiqued, and re-imagined for design potentials that are often overlooked over financial and vain incentives.

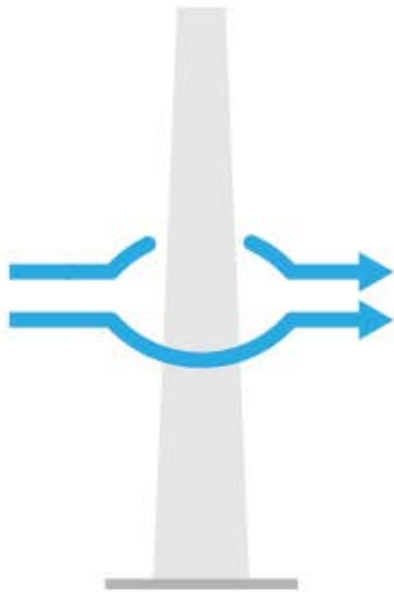

FLOW OF FORCES

Skyscraper is under tremendous pressure from the forces of nature.
Is there a structural form that the building naturally wants to be?



FLOW OF CIRCULATION

With taller buildings and higher number of users, the way in which the building circulates is crucial.
Is the traditional elevator system still viable?

The typology must be re-imagined in its totality through the fundamental re-understanding and re-investigation of the flow of elements that make the skyscraper possible.

FORM FOLLOWS FLOW.



FLOW OF ENERGY

Is there a way to use the height of the building as a source of energy?

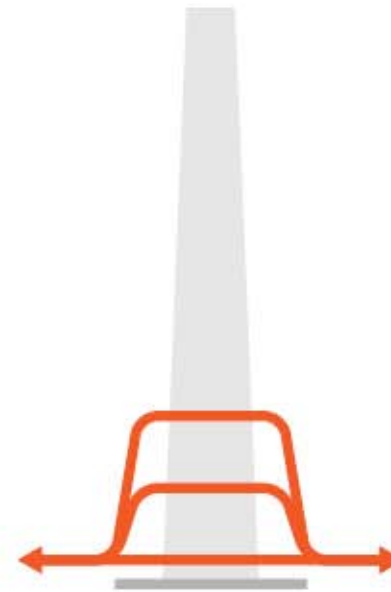

FLOW OF PROGRAM / CITY

Instead of a skyscraper that is an independent object, is there a way it could be integrated better into the urban fabric?

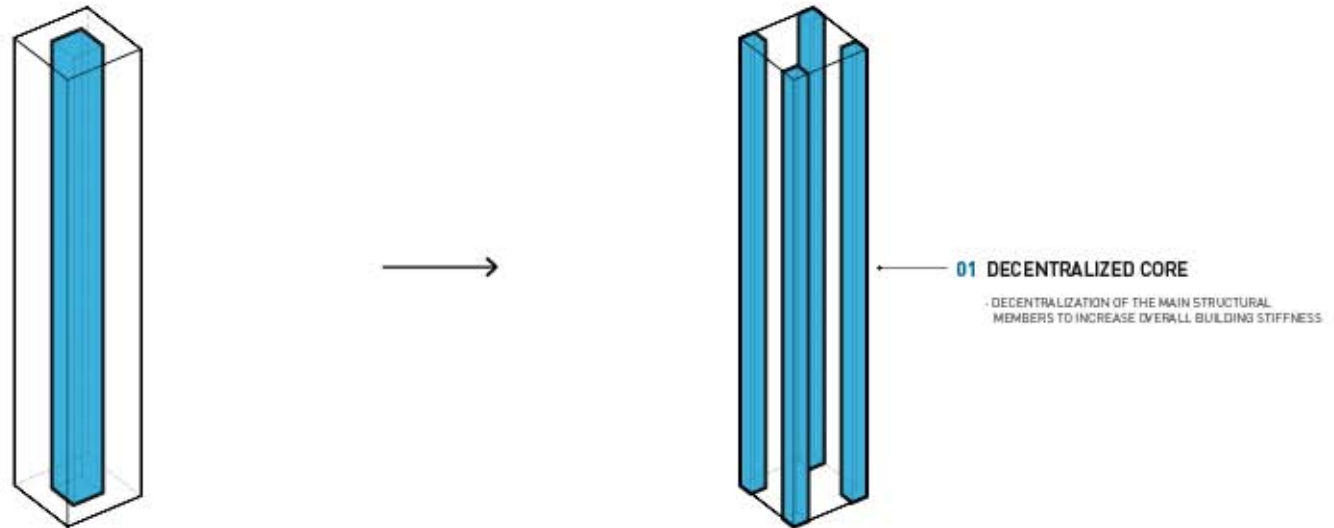

FLOW OF FORCES (1 of 3) : **MULTI-CORE**

Break the convention of the singular centralized core, to increase the overall stiffness of the tower with the same amount of core area and mass.

Service cores of the buildings are rarely located at the periphery of the skyscraper. Rightfully so, since it is preferred to have occupiable spaces at the perimeter of the building where daylight and views are maximized. The core of the building is the spine through which the main circulation, services and means of egress are enclosed. These elements are packed tightly into a

solid bundle. By virtue of it being a solid vertical mass, the core serves as the main lateral and vertical structure of the skyscraper.

Conceptually, skyscrapers are solid “sticks” encased with peripheral voids. For a building typology in which structure is such an integral part of the building, does placing

all the solid and the strongest elements in the center of the building footprint make the most sense? The easiest way to make a linear structural member stronger, is to distribute material to the periphery. This is evident in the sectional profiles of most commonly used structural members in practice: hollow sections (tubes) and wide flanges (I beams).

A tower structure is essentially a cantilevered beam or column with the ground plane acting as a fixed support. The critical force acting on a cantilever is the lateral load. The lateral loads can be caused by wind or earthquakes. Upon loading, the member's ability to resist bending is considered to be its "bending stiffness." In engineering, the bending stiffness can be expressed mathematically in terms of a "moment of inertia." Moment of inertia (I) is defined as "the planar area about a given axis that describes how difficult it is to change its angular motion about that axis" (Hibbeler, 2007). Mathematically, moment of inertia can be expressed as:

$$I_x = \int y^2 dA$$

where,

I_x = moment of inertia around axis/plane "x"
 y = the perpendicular distance from "x"
 dA = an elemental area

Basically, the stiffness of a cantilever is a function of its cross sectional profile (shape of the plan for a skyscraper) and the distribution of structural material (how much material is located away from the bending axis/plane). This means that for an arbitrary bending plane, stiffer and stronger profiles will have materials distributed as far away from the bending plane as much as possible. Placing the material closer to the bending plane does not improve its stiffness or strength. This is also why all structural systems are almost always

placed at the periphery of the building (see members colored in red in Fig. 49 and Fig. 50 next page).

Below (Fig. 48) is an illustration showing the effect of various configurations of the core with the same footprint in plan. The blue plane shown is the bending plane "x." Distance "y" is the perpendicular distance from the centroid of each element to the plane "x." It is a mathematical fact that placing the core at the center is structurally the worst possible scenario. This certainly does not mean that the entire exterior of the tower should be covered with heavy structural material. However, smarter distribution of the core may drastically improve its structural performance, without increasing the amount of material or cost.

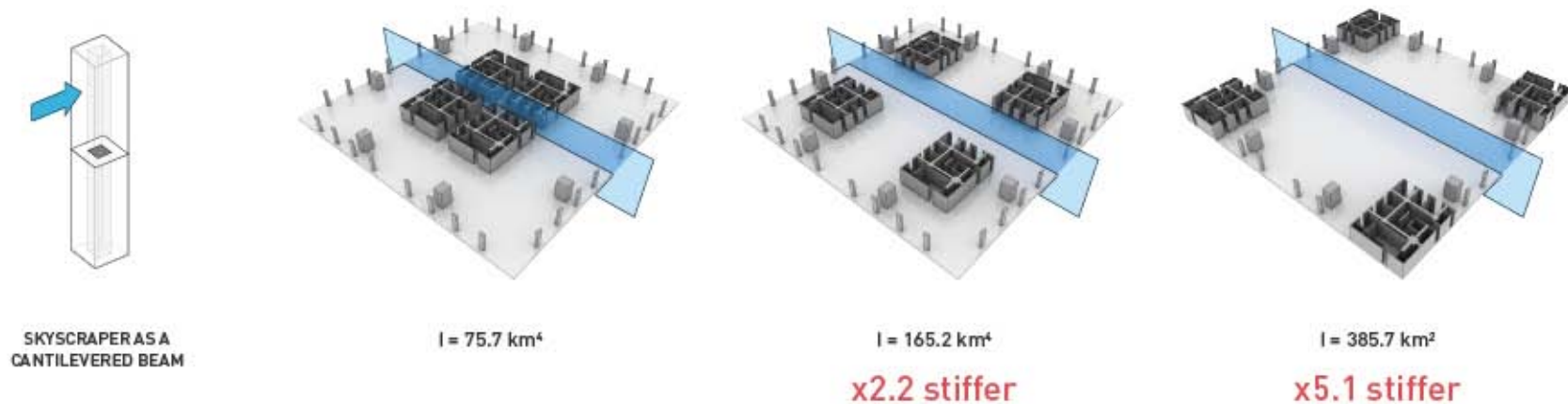

Fig. 48 Comparative analysis of various core layouts of the same floor area and mass, and its resulting effect on the stiffness of the tower.

Centralized core configuration is the unquestioned default design condition of the skyscraper. The objective of the secondary structural systems (typically at the periphery) has always been to support the centralized core, and push the century-old model to its limits. Over the past century, structural innovations for the skyscraper have always been add-on systems to the centralized core, and never manifested into newer models by integrating itself with the core.

Diagram to the right is the chronology of the structural systems of the buildings in the past century that was once the tallest building in the world. The overall structural systems of the building (colored in red), have been different, and unrelated solutions--as opposed to an evolution of a solution, to reinforce the central core. What remains constant in all the towers, regardless of its shape, height or slenderness, is the central core, which is colored in gray. The "buttressed core" model of the Burj Khalifa is the only system that is close to being a more directly integrated system with the core.

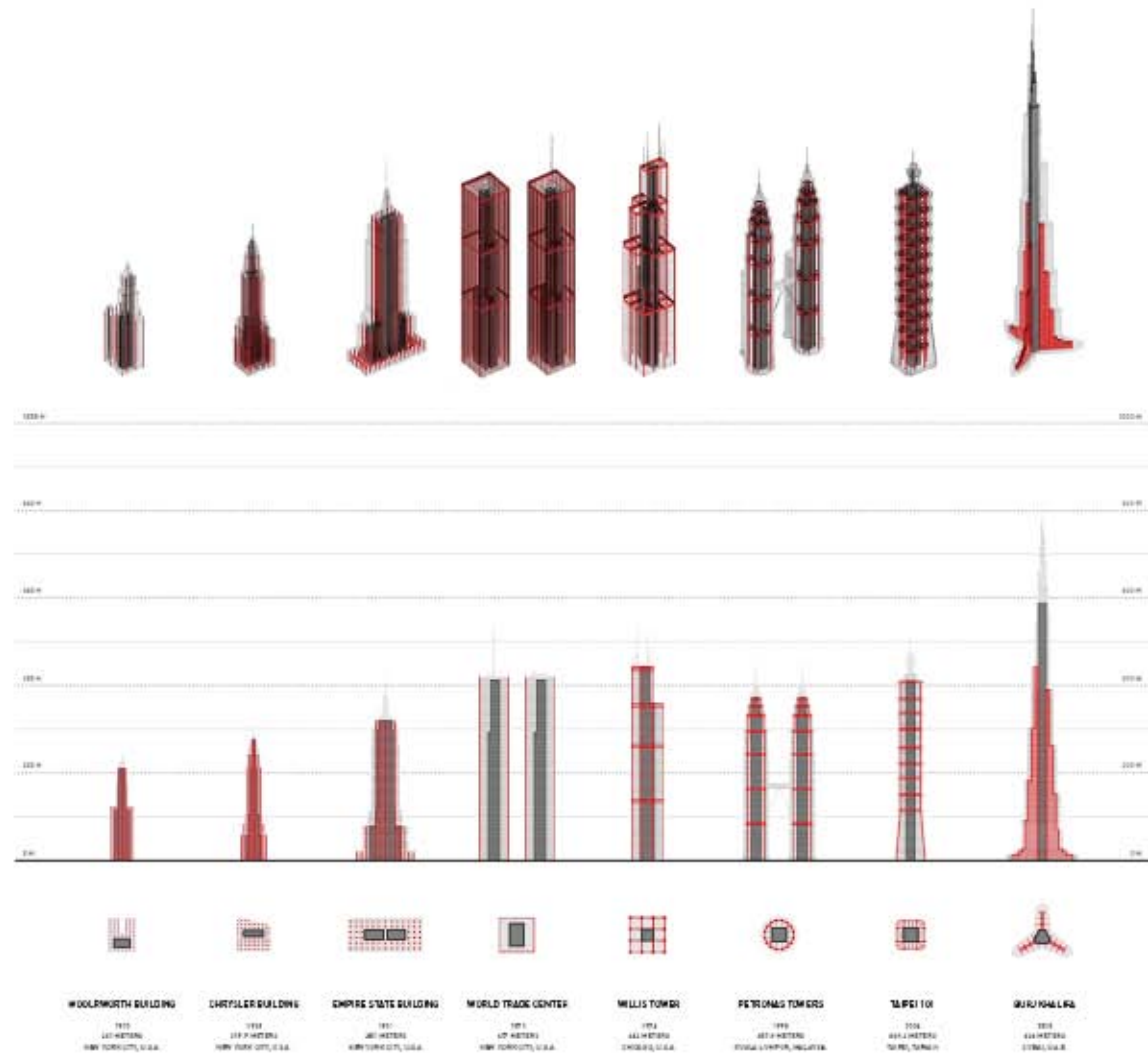

Fig. 49 "World's Tallest Building" Title Holders (Since 1913 - Present)

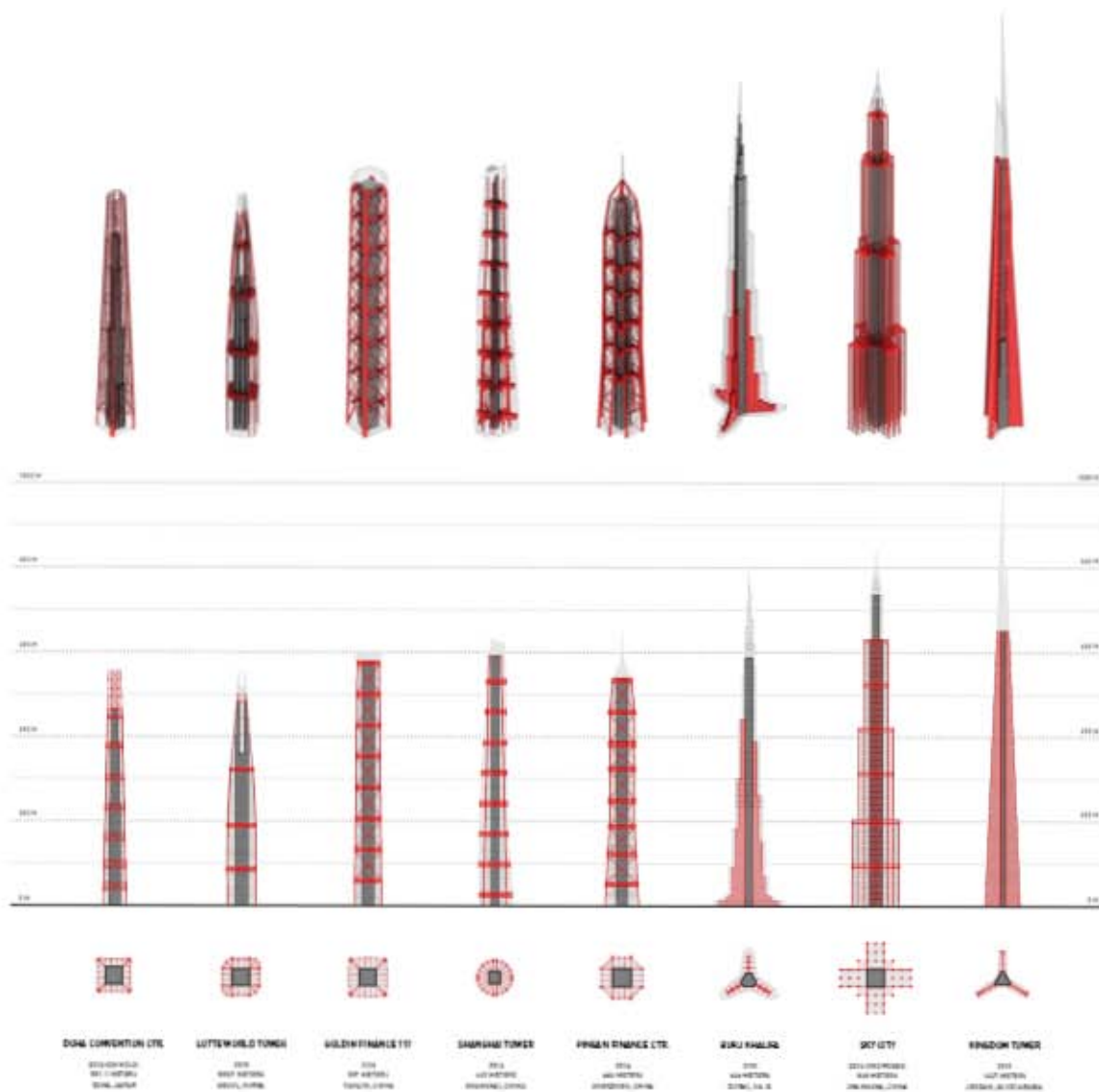

Fig. 50 World's Tallest 8 Buildings By 2020 (In Construction & Proposed, As Of September 2013)

Diagram to the left shows the eight buildings that will be tallest in the world in they year 2020. All but three are variations of the "core-and-outrigger" model, which is probably the most widely used in practice due to its ease of construct-ability. It is apparent that skyscraper are seeking the easiest and the cheapest solution, regardless of its shape, context or program. The reluctance to explore new structural ideas have brought typology into a standstill, lacking any signs of evolution or new opportunities.

Skyscrapers that are projected to be tallest in the world over the next decade, utilize structural systems that are most commonly used throughout the world. Clients are more inclined towards using previously proven systems to decrease risks, increase construct-ability and reduce overall building costs. However, the economically obvious and safechoice may not always be the most structurally efficient, architecturally interesting, contextually appropriate, or even performatively optimal.

Same core area = Smarter configuration/distribution = Higher performance

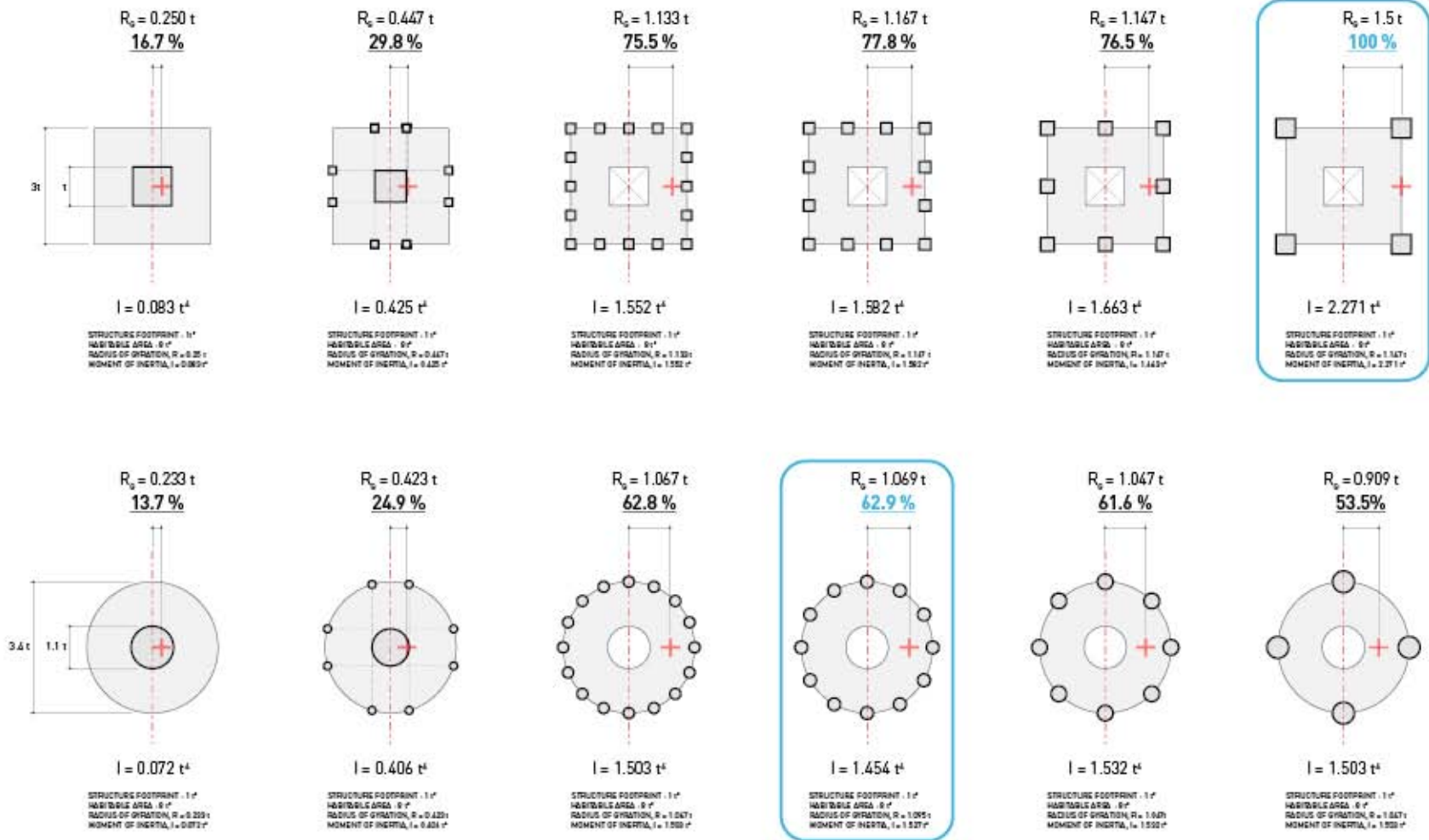
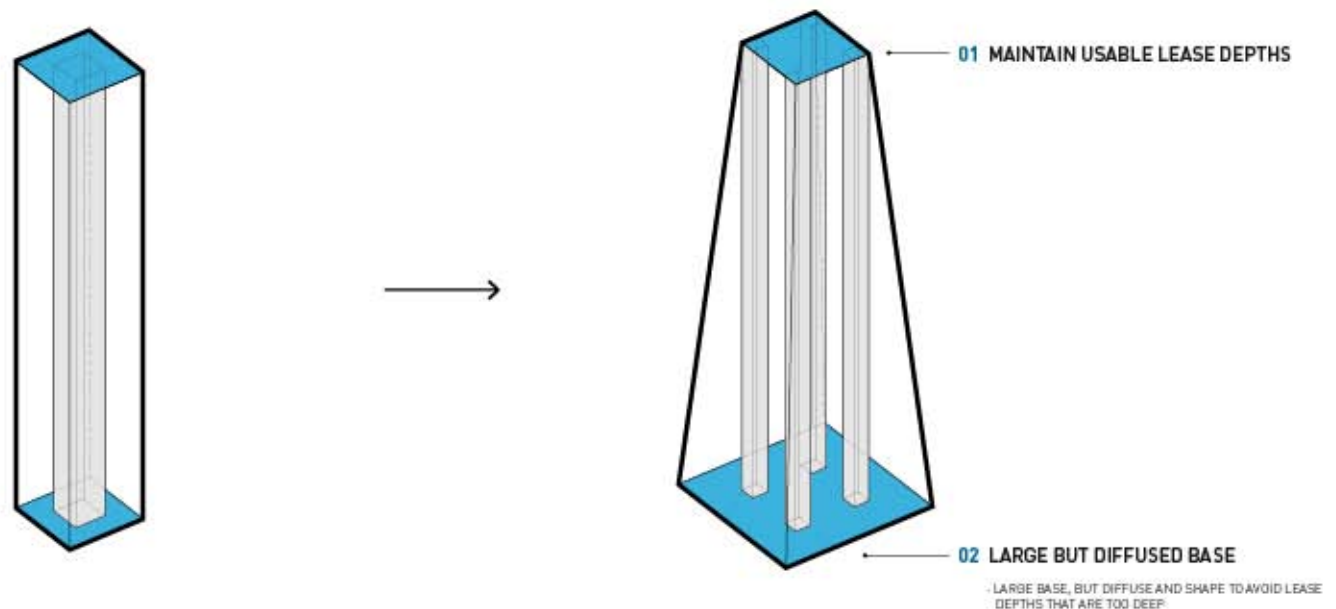

Fig. 51 Diagrams showing the detailed effects of various core configurations. In all options shown above, cores (shown in darker gray with thicker outline) have exactly the same area. The occupiable floor area also remains constant in all options.

INTENTIONALLY LEFT BLANK



FLOW OF FORCES (2 of 3) : **SMART TAPERING**

Refine the inevitable “pyramid” profile, while maximizing floor area at the tip, where the demand and the real estate value is the highest.

Stiffening the skyscraper from the inside by varying the configuration of the core is effective, assuming the building is firmly fixed to the ground. In reality, this is not true. Instead, if the building is assumed to be a detached, rigid mass sitting on the ground, its behavior around the base is of concern. The lateral load will cause an overturning moment, and push the mass to rotate

around an edge of the base, and tip over. The mass, with the help of its own weight, will naturally resist the overturning. The forces required at the base of the mass, is a pair of coupled forces in both tension and compression, at opposite ends of the base about the bending axis. The easiest solution to resist the overturning, is to increase the size of the base (see Fig. 52 next page).

Some of the tallest buildings in the world including the Burj Khalifa, are based on different variations of the tapered massing. With the same base dimensions, the tapered form is inherently more stable than the straight extrusion. However, the tapered massing has two problematic consequences. Up to a certain height, the tapered massing is effective. When the

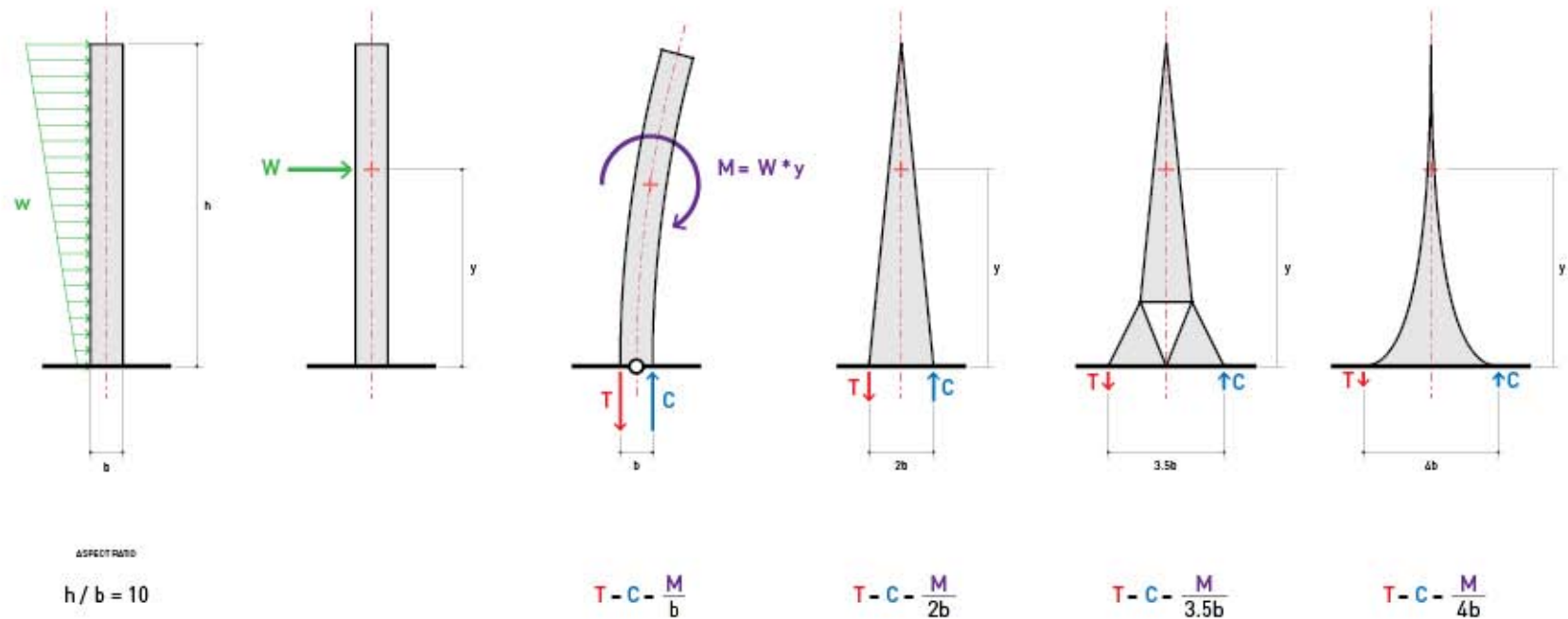

Fig. 52 The overturning moment is the global effect that the lateral loads have on the skyscraper. Narrower the base, the higher coupling forces of tension (T) and compression (C) is necessary to resist the overturning moment. Wider the base, lower the coupling forces, and hence smaller structural members required.

height increases, the length of the base must increase as well. This results in floor depths that are too deep at the base for any practical use, due to lack of daylight and long travel distances. Also, the thinning of the mass at the upper tip results in floor depths that are too shallow, and hence unusable for any meaningful program or floor layout.

Tapered form is inherently more stable than a straight extrusion, due to its wider base and lower center of gravity. At extreme heights, the tapered form becomes problematic, because the floor depths at the base become too deep, and too shallow at the tip. While more stable, the tapered form causes a significant amount of floor area to be unpractical and unusable.

Increase base dimensions = Increased Overall Stability = Deep Floor Plates

= Tower is too bulky and mostly unusable

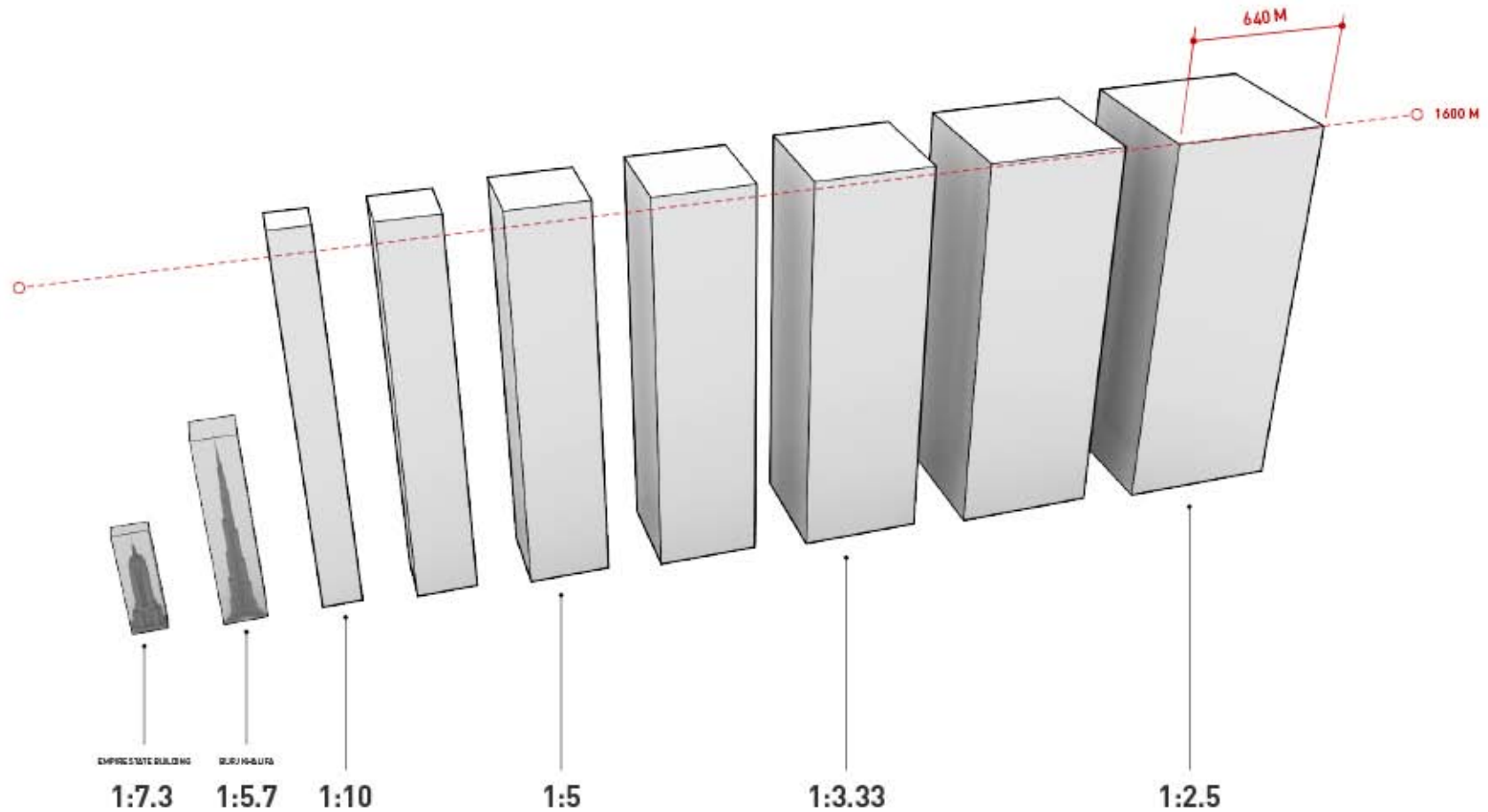

Fig. 53 Diagram showing the effect of increasing aspect ratio on towers of the same height. The towers will naturally be more stable with wider base, which results in a larger aspect ratio [height over the maximum length at base]. However, the depths of the floor plates become so deep that central area of the tower becomes impractical due to lack of daylight, views and long travel distances.

Tapered massing = Decrease floor depths at upper levels = More usable overall

= Mostly unoccupiable space at top (where floors are the most valuable)

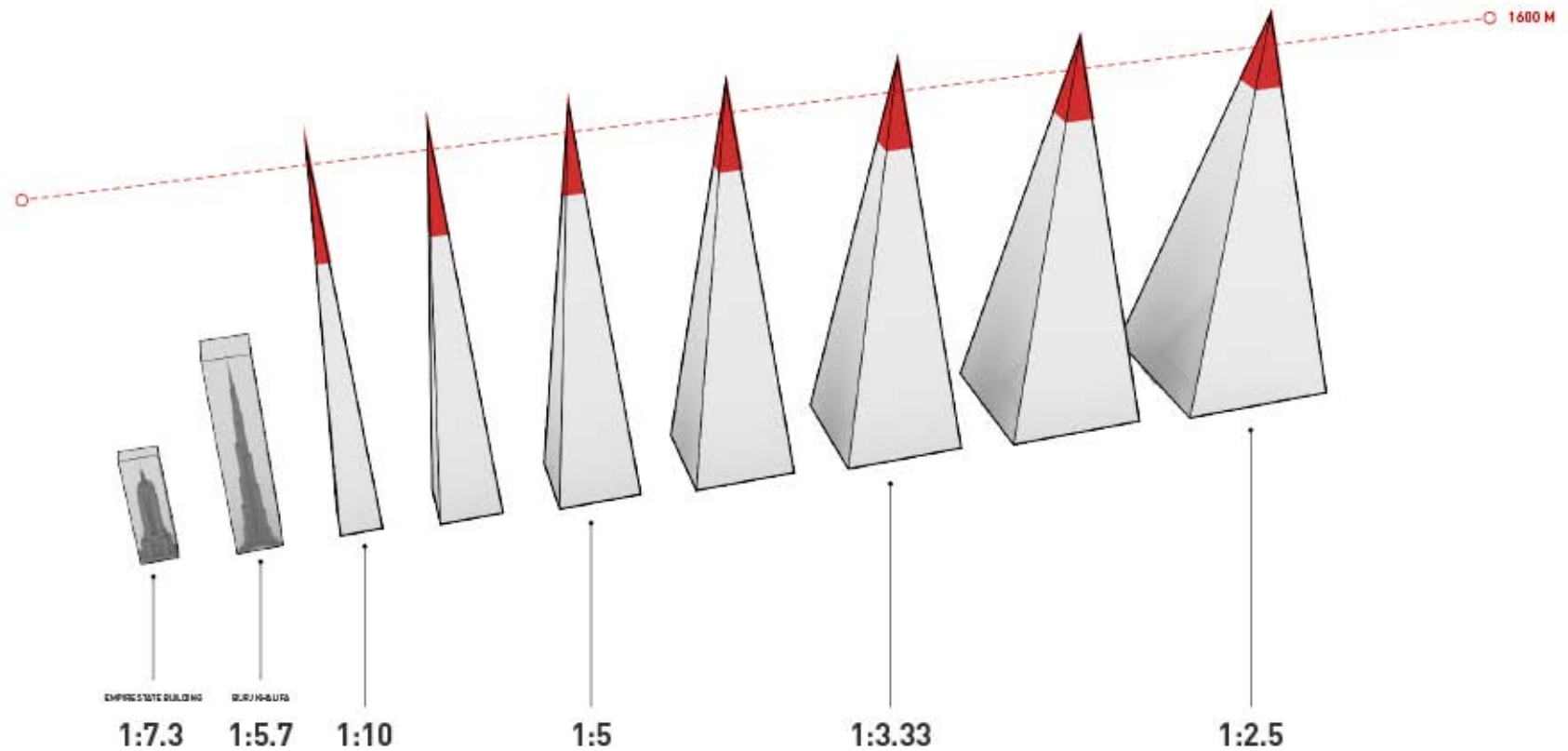
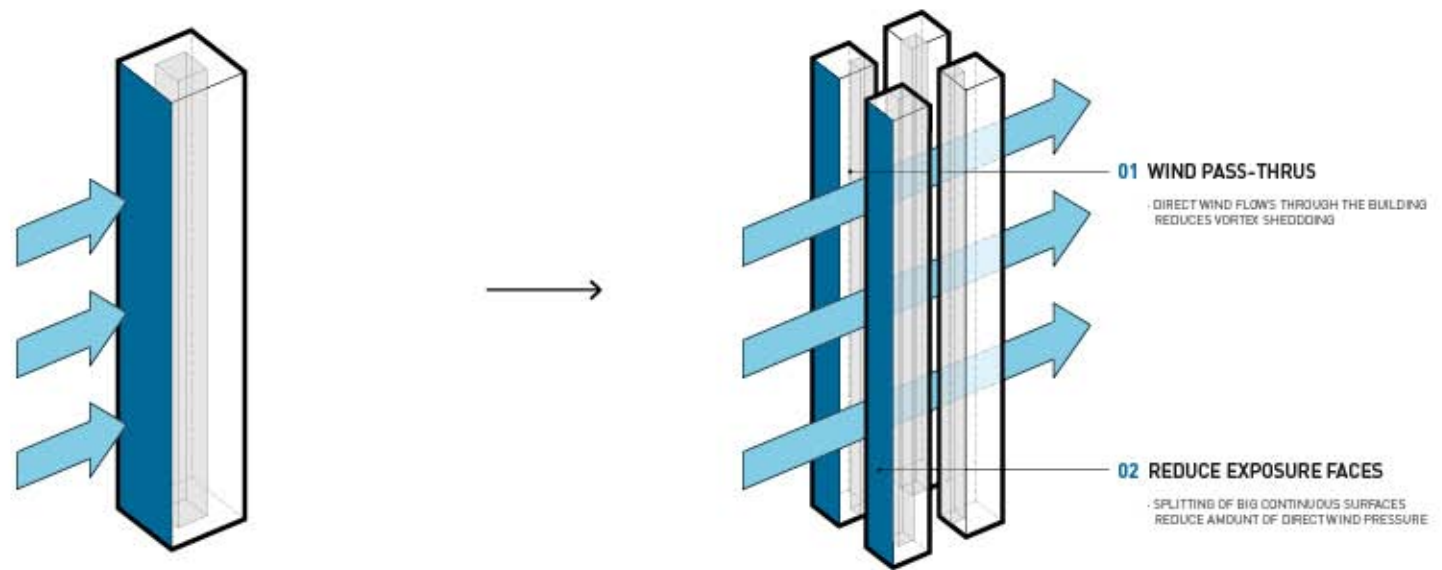

Fig. 54 Diagram showing the effect of increasing tapered massing. While maintaining the same aspect ratios, floor plates can be made more practical and usable by tapering the massing and thereby reducing the floor depths. However, the tapering strategy becomes a paradox, because the tip of the towers become unoccupiable due to shallow floor depths.



FLOW OF FORCES (3 of 3) : WIND CARVING

Split tower into smaller masses for: 1, more feasible floor plates; 2, minimize wind pressure, the largest external force imposed on the tower.

For high rise buildings, lateral loads imposed on the building due to wind is more critical than the vertical gravity loads. When the building's height becomes far greater than its width at the base, wind load is the most influential force in designing of the overall building structure. Wind velocity and pressure also increases exponentially with increasing altitude, which makes wind

loading even more critical for extremely tall and slender towers.

Structure of these slender towers must be able to transfer enormous lateral loads vertically down to the base of the building where it meets the ground. Combination of transferring the lateral loads to vertical loads, and shaping the tower mass into

an aerodynamic form makes the shape of the structural system to be the dominant factor in determining the shape of the tower. Hence, for tall slender towers, structure of towers naturally is the architecture.

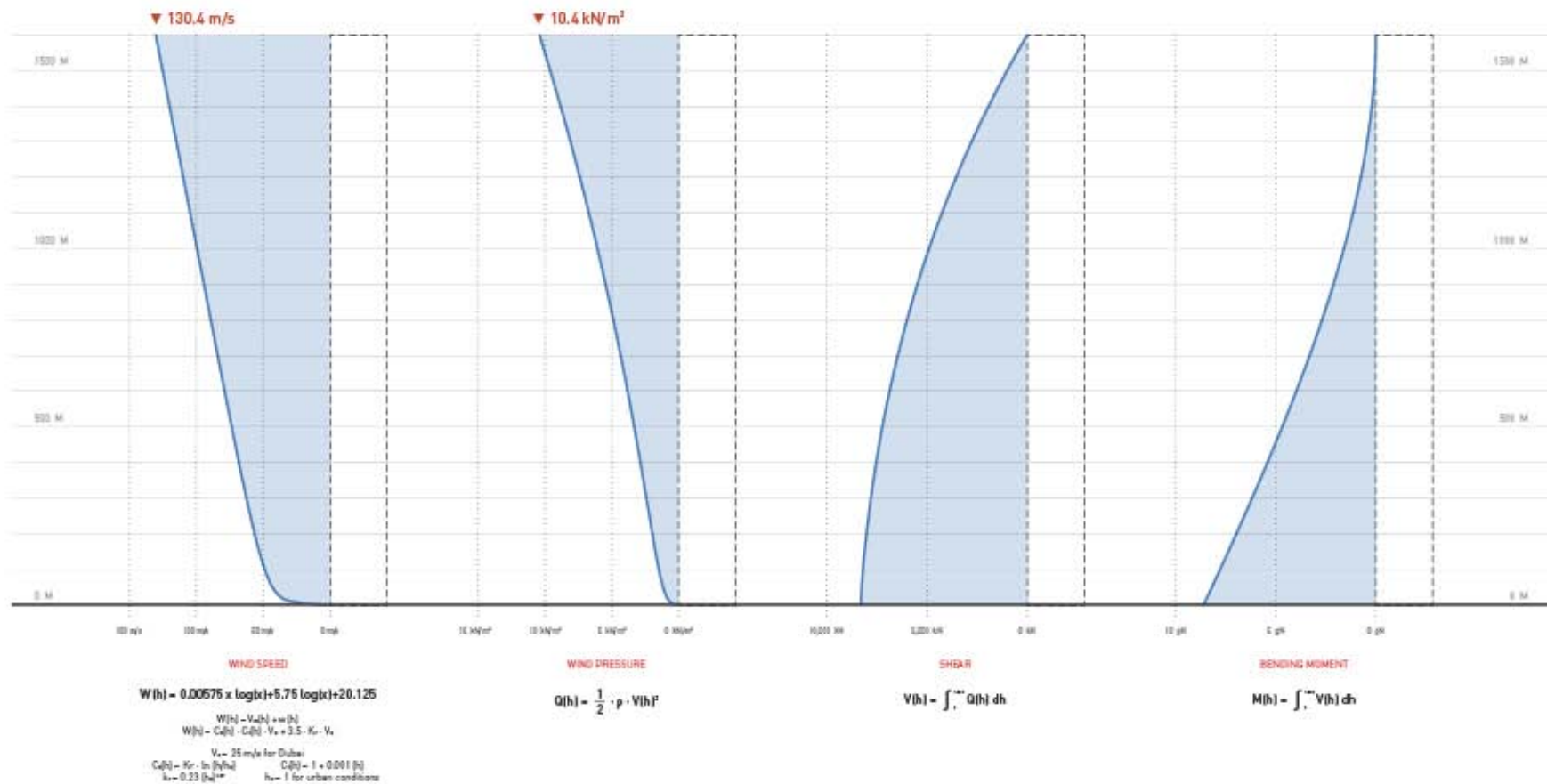

Wind velocity increases exponentially with rise in altitude. At 1600 meters above ground, wind velocity is nearly five times faster than it is at ground level. In theory, and according to most building codes used throughout the world, the wind pressure is a function of atmospheric air density, times wind velocity, times the square of altitude. Hence, the wind pressure at 1600 meters in altitude, is nearly ten times as much as it is at ground level.

Fig. 55 [Above] Diagrams in elevation, showing the effect of altitude on wind velocity and pressure. Base wind speed at 10m height is assumed to be 25 m/s. All other values and equations are based on the regional wind code [Dubai Municipality, 2013].

Engineering of the skyscraper has always been an effort to resist and withstand wind forces. Therefore, **the final architectural massing of skyscrapers are always direct translation of its structure.** By using splits and gaps as integrated features of the building massing, the wind pressure can be reduced, while providing more opportunities to explore unconventional massing strategies.

The wind can have two major effects on a skyscraper: 1, the direct pressure on the windward side; and 2, the indirect pressure on the leeward side that causes side-to-side swaying motion, or other unexpected dynamic behavior. Today's engineering of skyscrapers are focused on optimizing the massing of the skyscraper as a single entity, and optimizing its structural behavior against wind. Instead of trying to engineer against the wind, could unforeseen opportunities be discovered by trying to engineer with the wind? Can wind pressure be used as a design tool, to break the conventional massing strategies instead of simply reinforcing it?

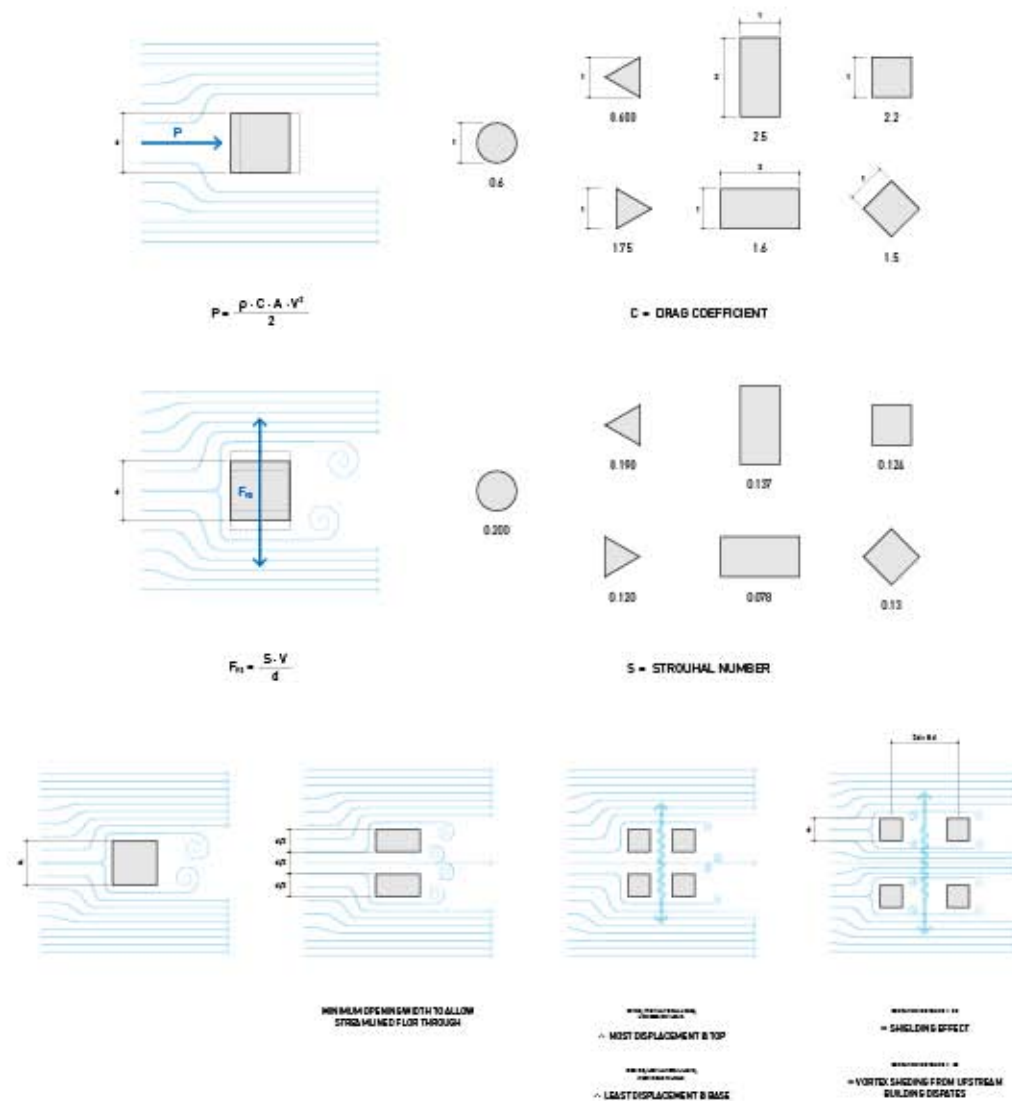

Fig. 56 Diagrams in plan, showing the effect of variation in geometry and orientation on resulting wind pressures. Forces of interests are: 1, Drag (direct wind pressure); 2, SWAY (result of indirect pressure such as vortex shedding); 3, Thru-wind (Halvorson and Partners, n.d.)

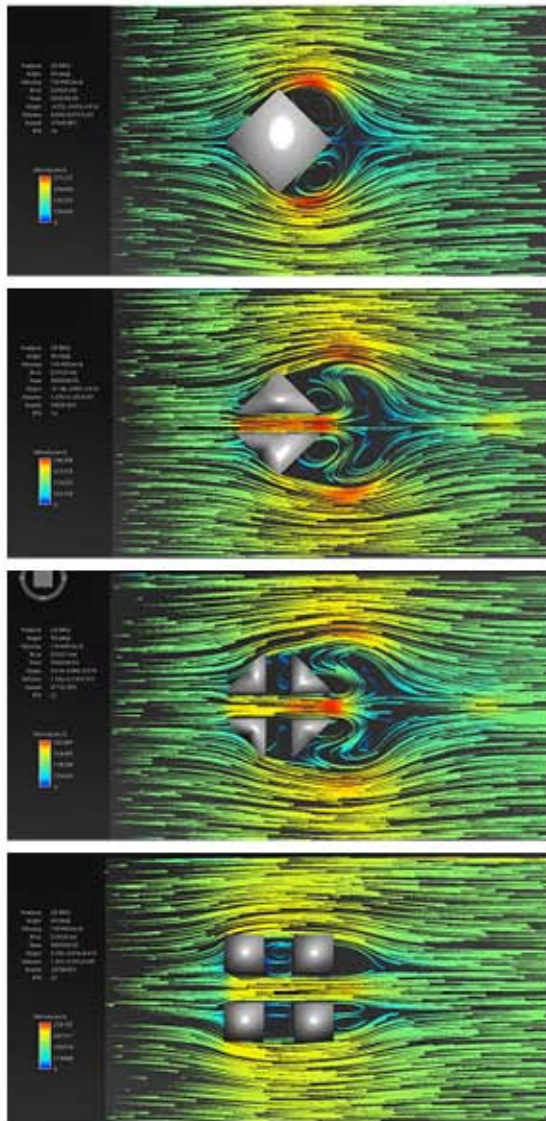

Fig. 57 Autodesk Falcon Computational Fluid Dynamics analysis in plan, of variations of a square tower.

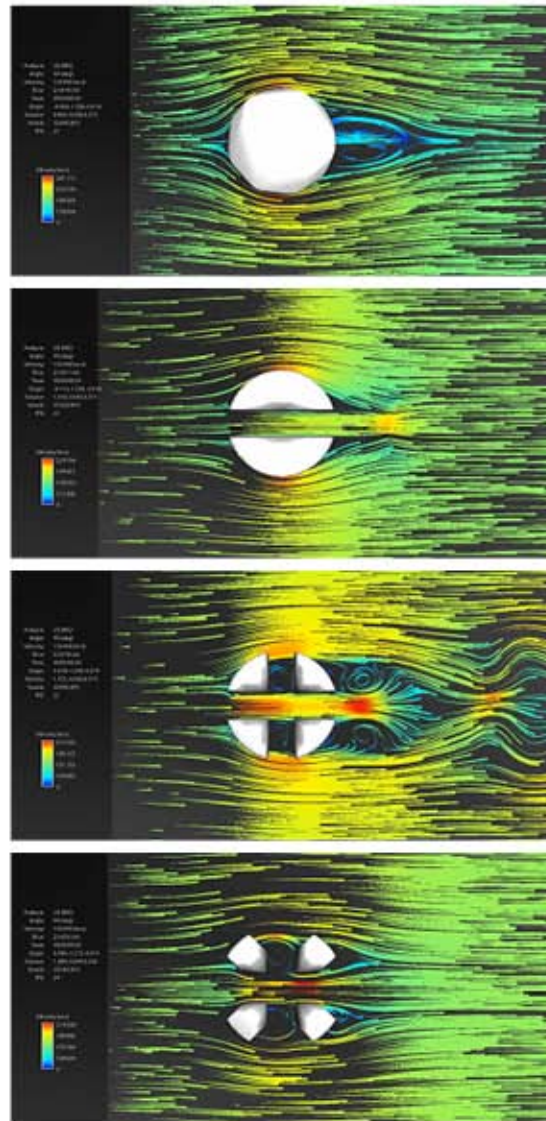

Fig. 58 Autodesk Falcon Computational Fluid Dynamics analysis in plan, of variations of a circular tower.

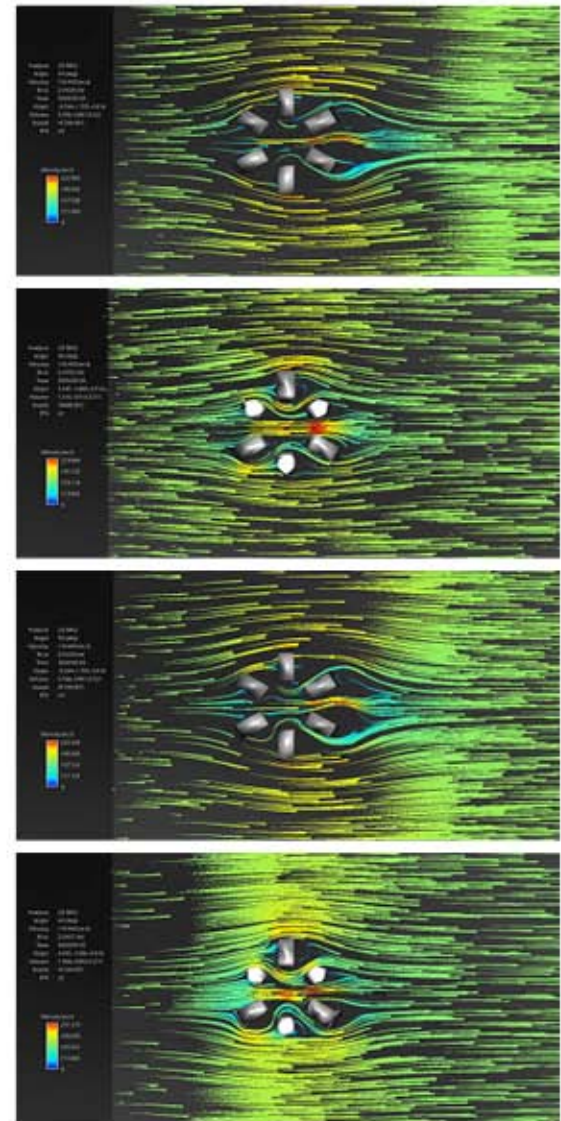
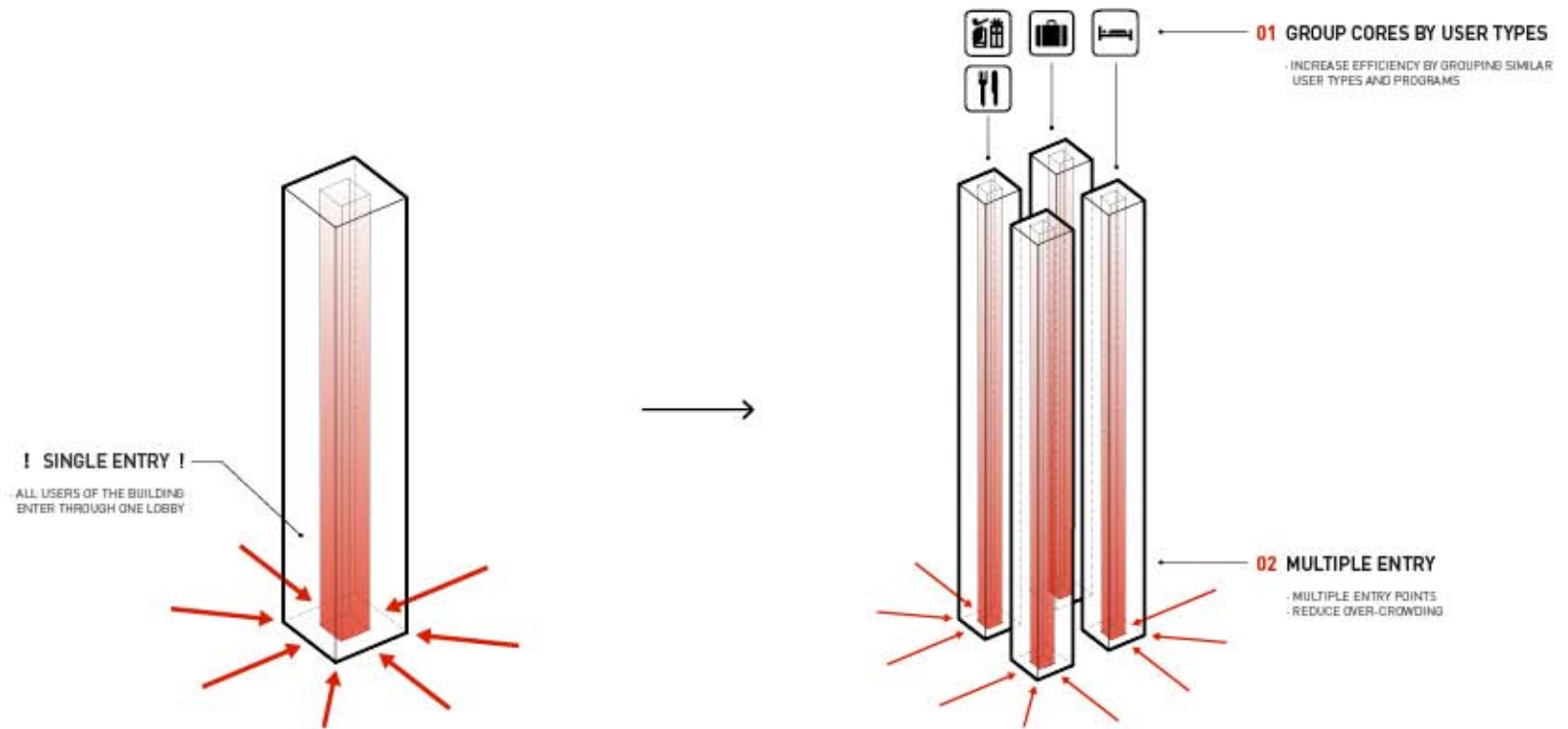

Fig. 59 Autodesk Falcon Computational Fluid Dynamics analysis in plan, of variations of a tower with multiple slits.



FLOW OF CIRCULATION (1 of 3) : **MULTI-CORE**

Instead of a single core shared by all users, distributed cores that are dedicated to specific user types will increase overall efficiency and reduce redundancy.

All users of a skyscraper enter through the same entrance at the ground level. For tall skyscrapers, the number of users increase, and consequently increases the required number of elevators to service the building.

Unless the base of the building keeps growing with the increasing footprint of the core, the lower levels of the skyscraper will eventually be filled up with elevator shafts with increasing height of the building. By

diffusing the singular core into smaller, user-specific bundles of elevators, the efficiency could be drastically increased, and overcrowding and redundancy could be reduced.

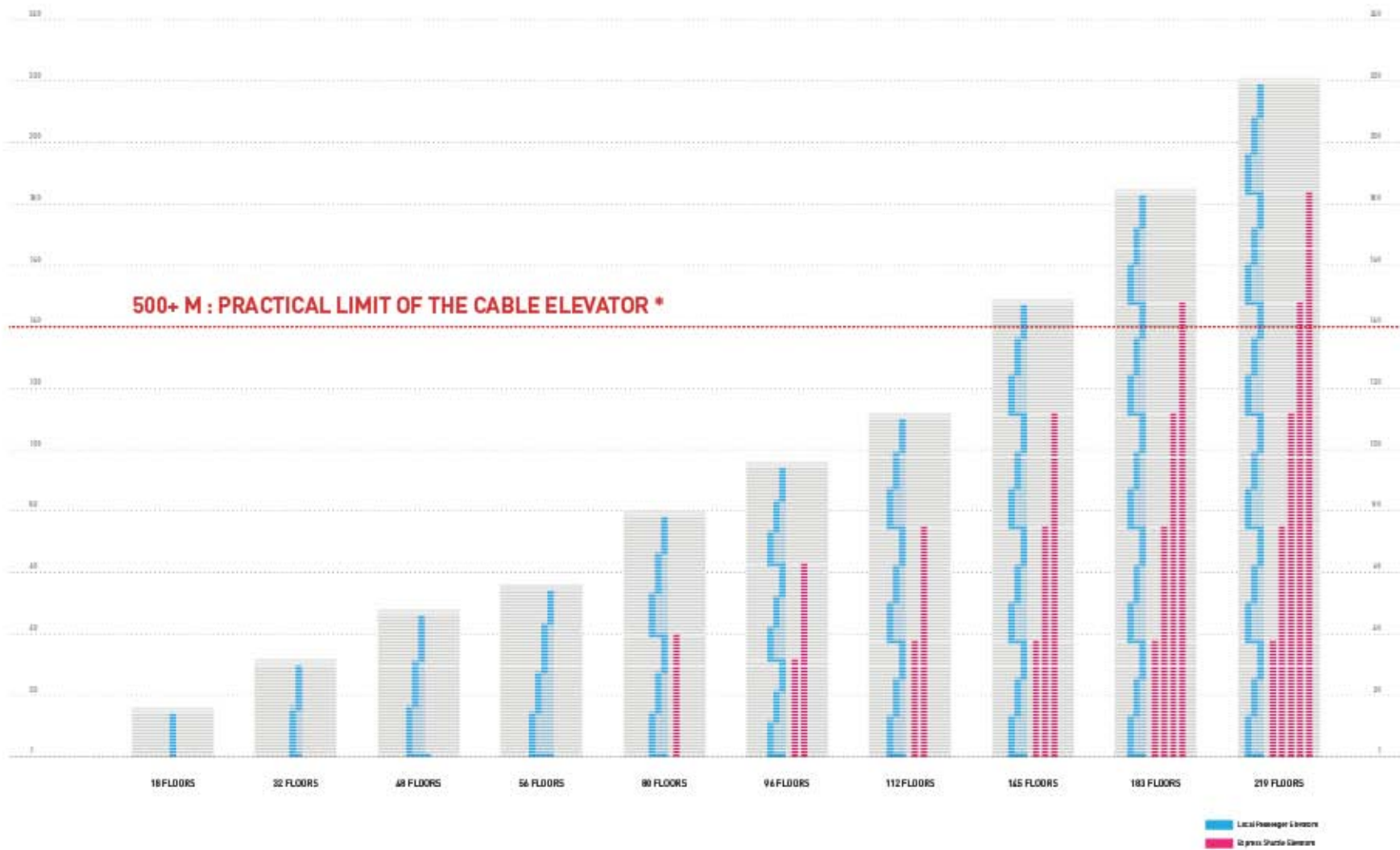
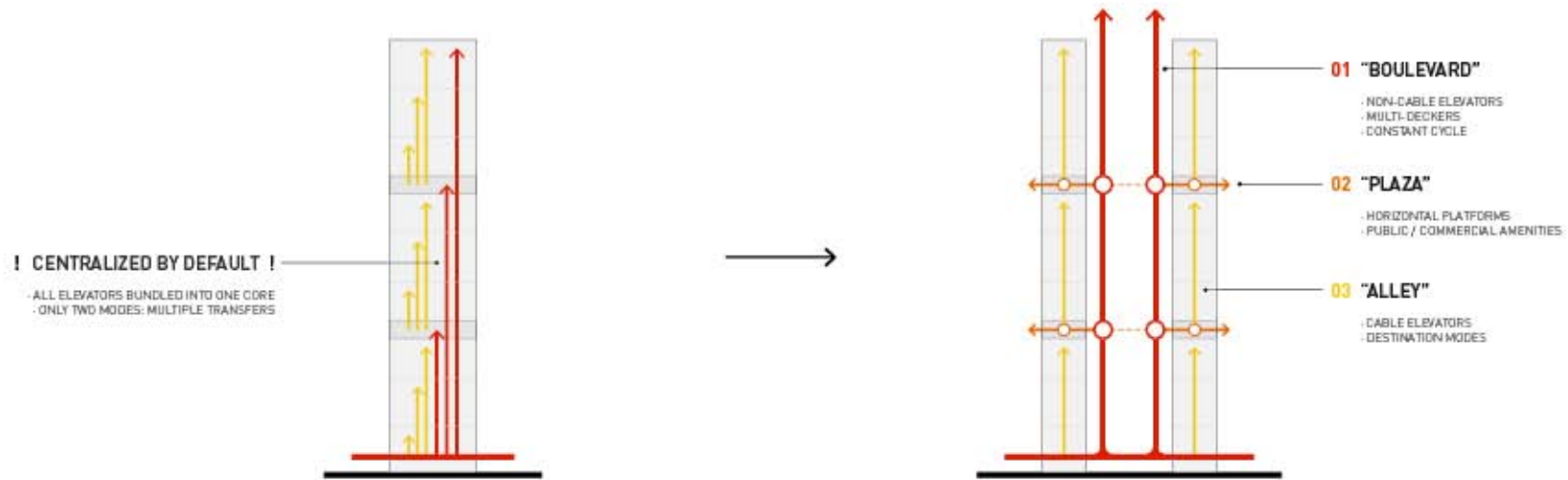

Fig. 60 Diagrams in elevation, showing the necessary elevator configuration for towers of the same base dimensions with increasing height. Even with the computer assisted, "destination system" that has become the norm today, the number of necessary elevators and shafts start to take up a substantial amount of floor area, and therefore increasing the lease-able capacity of the tower. At lower levels, the tower is mostly just elevators. [Ascher, 2011]



FLOW OF CIRCULATION (2 of 3) : HIERARCHY

Establish a hierarchy of circulation, and layers of “vertical streets.” Transfer levels can be infused with public programs, and create “city plazas.”

Cable elevators have a physical limit on how high it can travel, because the length and the weight of the cable necessary become too great with increasing height. Therefore, the users of the upper levels of a skyscraper must take an express elevator to a transfer level, and switch onto a local elevator to reach the destination. The express and local elevators are bundled into a single mass,

and are often stacked on top of one another. For an extremely tall skyscraper, where the number of users are significantly higher, the variety of program types more diverse, and number of elevators exceeding a hundred, the introverted circulation system within one vertical mass may become problematic. It causes vertical separation between various programs, and complete

disregard for interaction between users, which becomes an important variable as extreme skyscrapers evolve from buildings to true “vertical cities.” An organized hierarchy of “vertical streets” and platforms will subdivide the building into more livable, city-like conditions, and allow various parts of the skyscraper to have relationship with one another, like an urban fabric does.

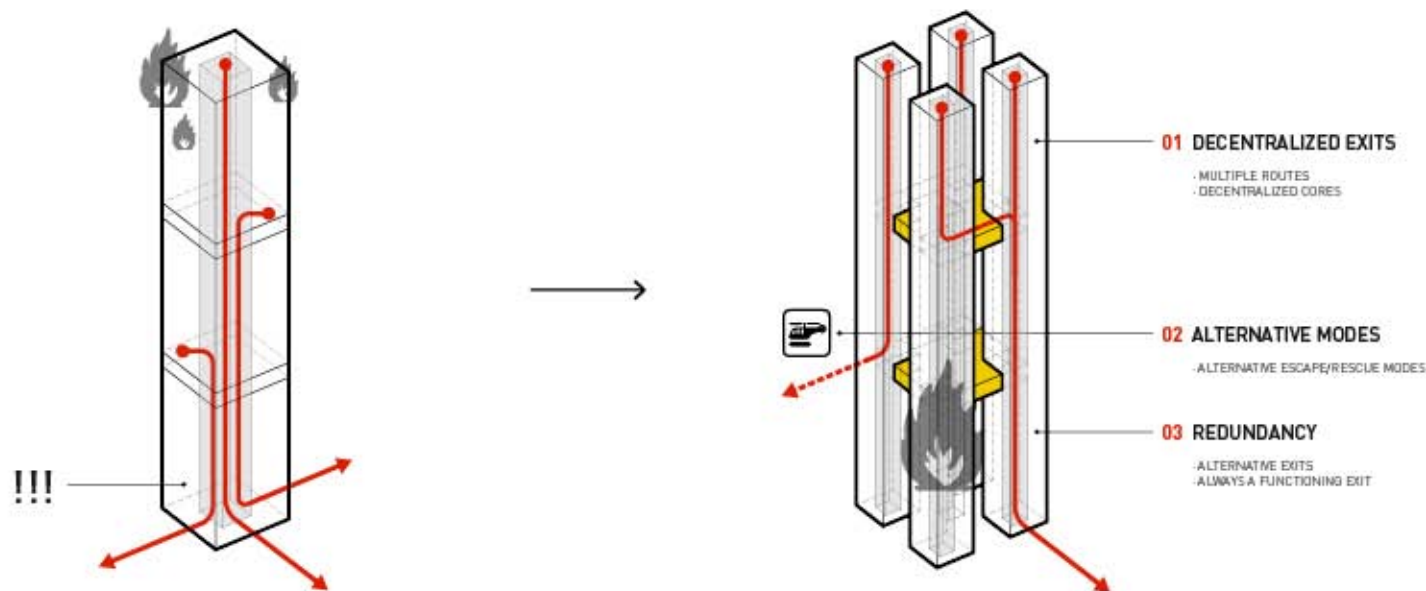

FLOW OF CIRCULATION (3 of 3) : EGRESS

Multiple means and methods of egress and escape routes; Place vertical egress corridors away from the center for increased redundancy.

Conventionally, emergency egress stairs and elevators are also incorporated into the central core. With taller towers with increased capacity, the central core would house multiple egress stairs to meet the capacity. In case of an emergency, all users would congregate to the center, and exit through the same vertical axis. If the central core becomes structurally or functionally

compromised, how would the users exit out of the building?

With a large number of people needing to travel down the long staircase and out of the building, distributing the secured and safe egress corridors throughout the footprint of the building helps decrease the "bottleneck" effect and a more even

distribution of the egress traffic. Multiple egress corridors also means that there is a redundancy in the system, and ensures that there is always an alternative way out of the building, if one corridor becomes unusable. Distributed corridors also forces users away from the center of the building to the periphery as opposed to converging them to the same crowded location.

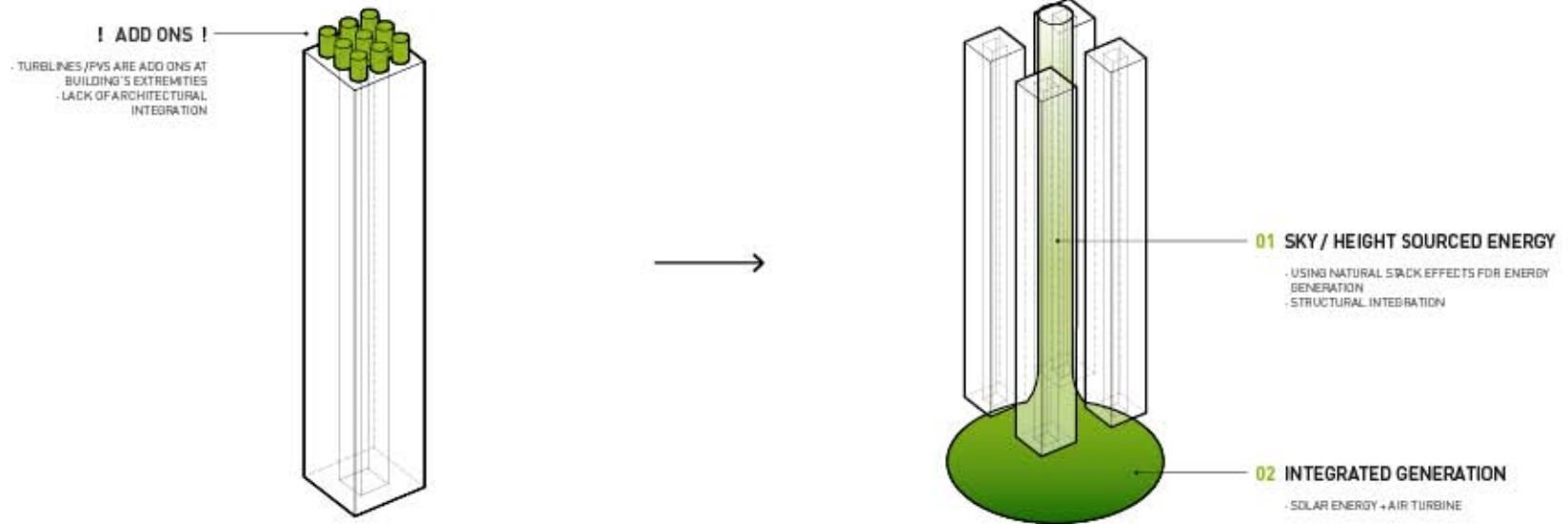

FLOW OF ENERGY (1 of 2) : HEIGHT AS ENERGY

Instead of add-on, “eco-blings” that are mere decorations without any significant energy output, height itself can be used as source of consistent energy generation.

Skyscrapers consume tremendous amount of energy and resources to sustain itself. Recent sustainability movement has inevitably made the typology more conscious and sensitive to its impact on the environment and the urban grid. New strategies of reducing consumption are incorporated into the design of the skyscraper, and in some cases, features are

added to generate power. More often than not, these are add-on pieces that are placed after most of the design work has already been finished, and function as decorations rather than meaningful sources of energy. In addition, these elements are turbines driven by wind, or photovoltaic panels heated by the sun. Outputs of these features are heavily dependent on the unpredictable

and uncontrollable weather conditions. Instead of using attachments that do not even generate any useful amount of power output, can the height itself be used as an energy source?

Height has been used before in vernacular architecture as environmental features. Wind-towers of the Middle East are notable

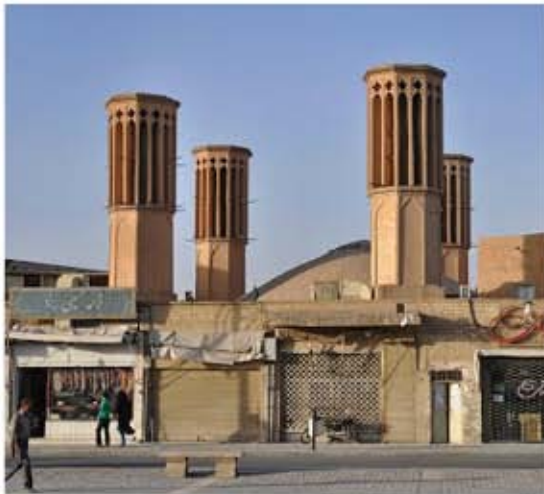
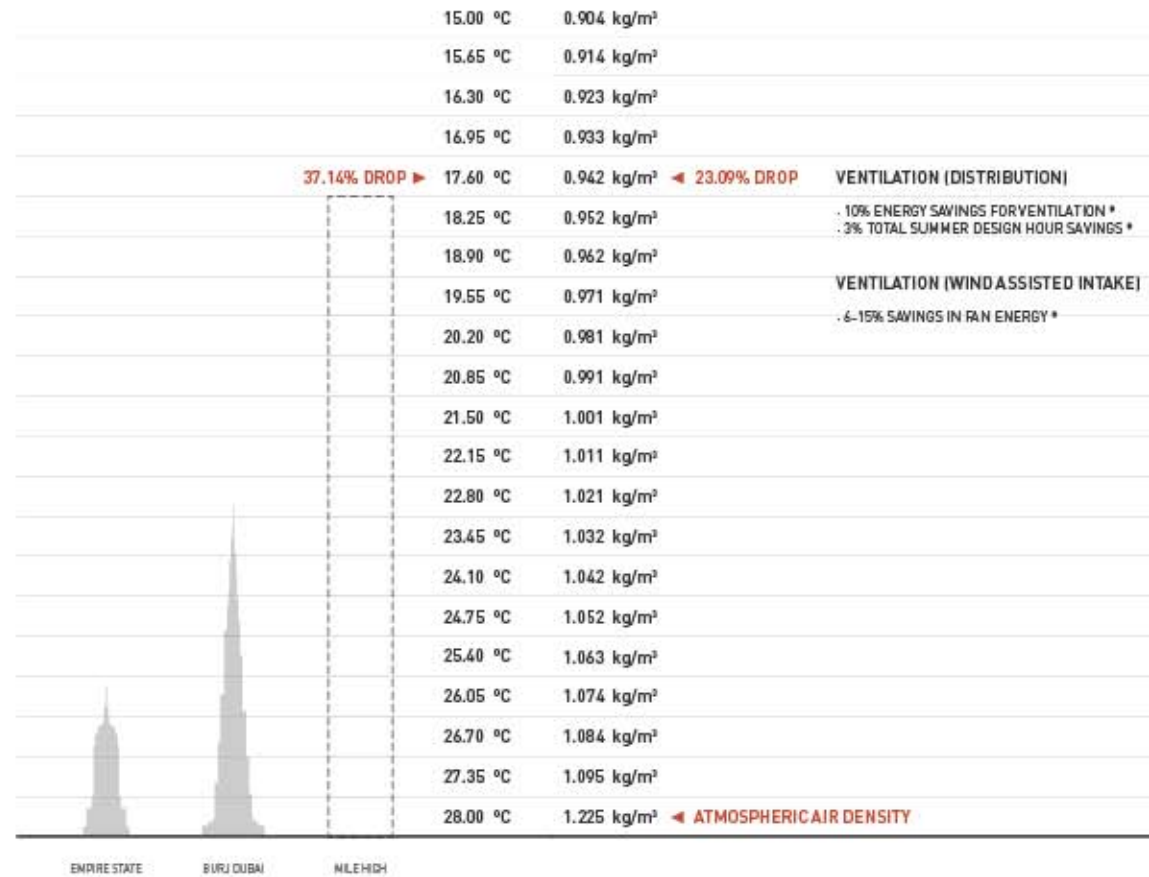

Fig. 61 (Above) Traditional wind-towers of the Middle East region.

Fig. 62 (Above right) Effect of rising altitude on atmospheric air temperature and density, according to Atmospheric Properties Calculator based on the US Standard Atmosphere 1976 Version 2.1.4, released in August 2005 (Aerospaceweb.org, n.d.).



examples of this, using the natural stacking of hot and cool air to passively ventilate the buildings. Cool air tends to sink, and warm air tends to rise. Within a skyscraper where height is already available, this stacking effect can be accentuated to extract energy from the resulting air movement. In a generally warm climate, using stacking effect as a power source is more reliable

than the traditional wind turbines (which only work on windy days) and photovoltaics (which do not work as well on cloudy days). Turbines can be placed at the base of the tower where the vertical movement is the strongest, to generate clean energy around the clock to service the tower itself, and potentially its neighboring buildings as well.

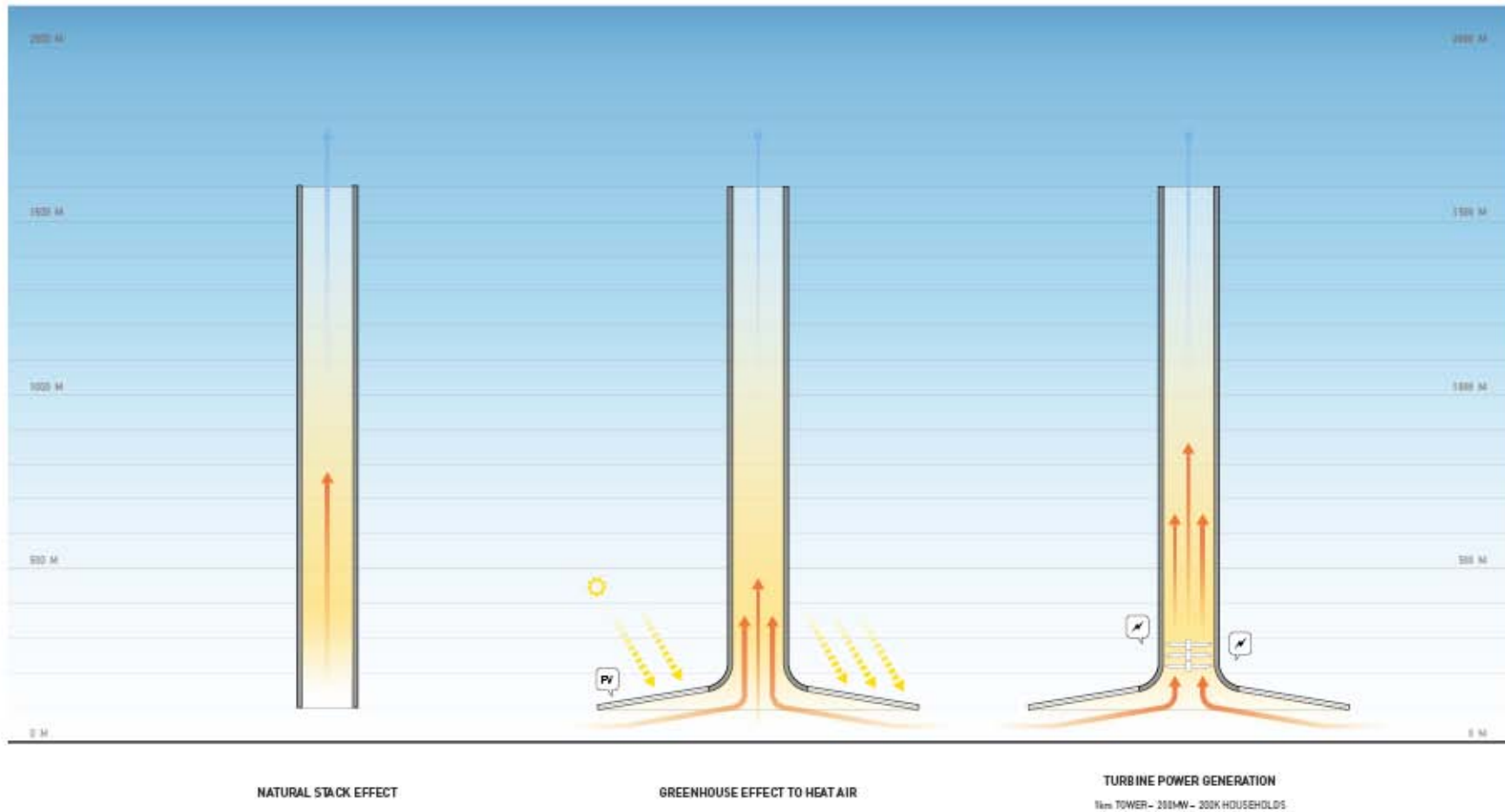
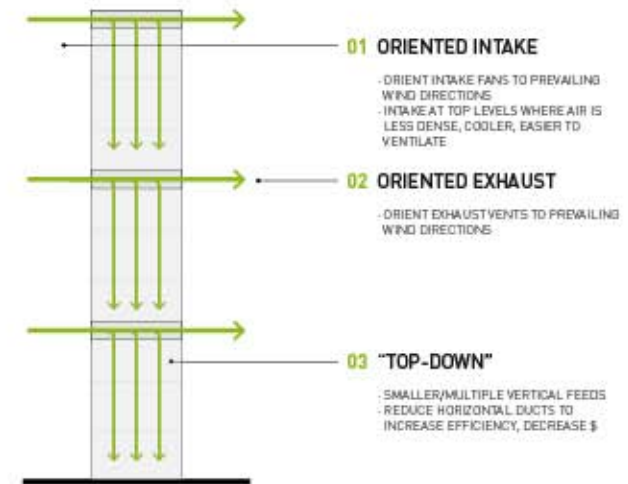
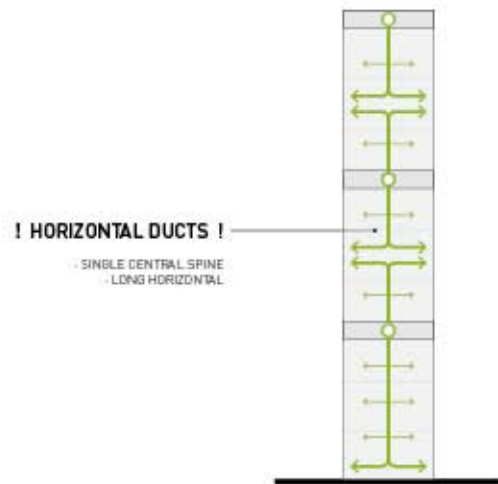

Fig. 63 [Above] How a solar updraft tower works.

Fig. 64 [Right] Power output capacities of solar updraft towers of various heights and sizes. A tower that is a kilometer tall can potentially generate enough power to sustain 200 thousand households [Bosschaert, 2009].

POWER OUTPUT	DIAMETER / AREA	TOWER HEIGHT
50 kW	0.25 km / 0.05 km ²	195 m
40 MW	1 km / 3.5 km ²	750 m
10 MW	2.5 km / 20 km ²	1000 m
200 MW (200k households)	3.4 km / 38 km ²	1000 m



FLOW OF ENERGY (2 of 2) : **TOP-DOWN M.E.P.**

Air is cooler, cleaner and lighter at higher altitudes, meaning less fan energy is required to circulate the air.

Conventionally, the mechanical system of a skyscraper is a network of vertical and horizontal ducts. Central core feeds the floors vertically with clean air, and then the air is ventilated through horizontal ducts. Naturally, air does not move sideways, which is why buildings need to depend on fans to ventilate air throughout the buildings. Since the natural movement of

air is up or down, could the horizontal ducts and fans be eliminated by using diffused vertical ducts?

Air is also cooler and lighter at higher altitudes. Lighter air means that less fan energy is required to ventilate it. Cooler air means less dependency on air conditioning to cool the air down to a desirable

temperature. It also means that from the point of intake, the air can be fed into the building by letting it naturally sink into the building evenly, instead of converging it into a single source then redistributing it horizontally. Vertical void elements in the building can be used for dirty, warm air to rise up and exit out of the building naturally.

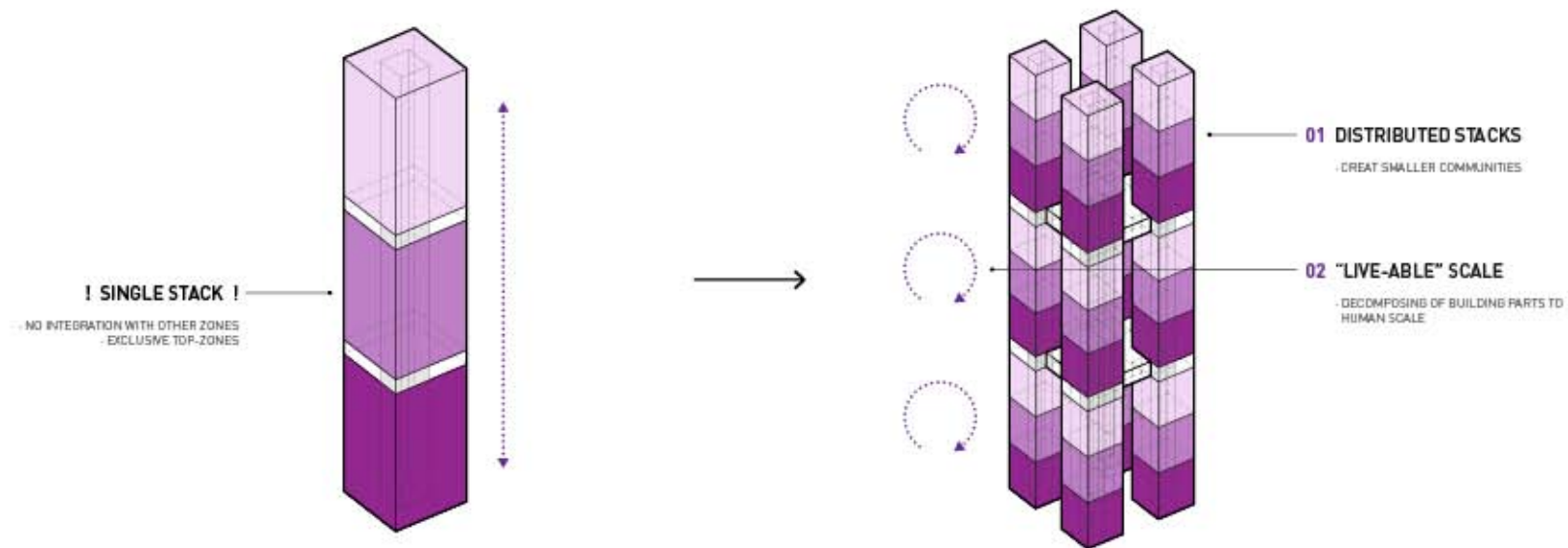

FLOW OF PROGRAM (1 of 2) : **SUBDIVIDED STACK**

Subdivide the skyscraper into smaller segments, and distribute program into smaller stacks that are more appropriately scaled to form a livable community.

Skyscrapers typically have multiple program elements. These program elements are stacked on top of each other to make a mixed-use building. Different programs types have varying criteria for the ideal floor shapes and depths. For example, large continuous floors desired for offices, physically do not work for residential and hotel layouts, where shorter floor depths

and proximity of each unit to perimeter of the building is desired.

Consequently, program types are almost always grouped into single zones, and are rarely distributed throughout the height of the building. With rising height and growing number of floors, This method of stacking becomes problematic. A hundred floors

of residential sitting on top of a hundred floors of hotel and a hundred floors of office causes internal isolation of each of the program types. With the large number of people in the building at any given type in a building of this magnitude, scaling down the internal organization to a more human and "livable" neighborhood scale must be addressed.

Typically, skyscrapers are singular stacks of programs, with each stack having no relationship with one another.

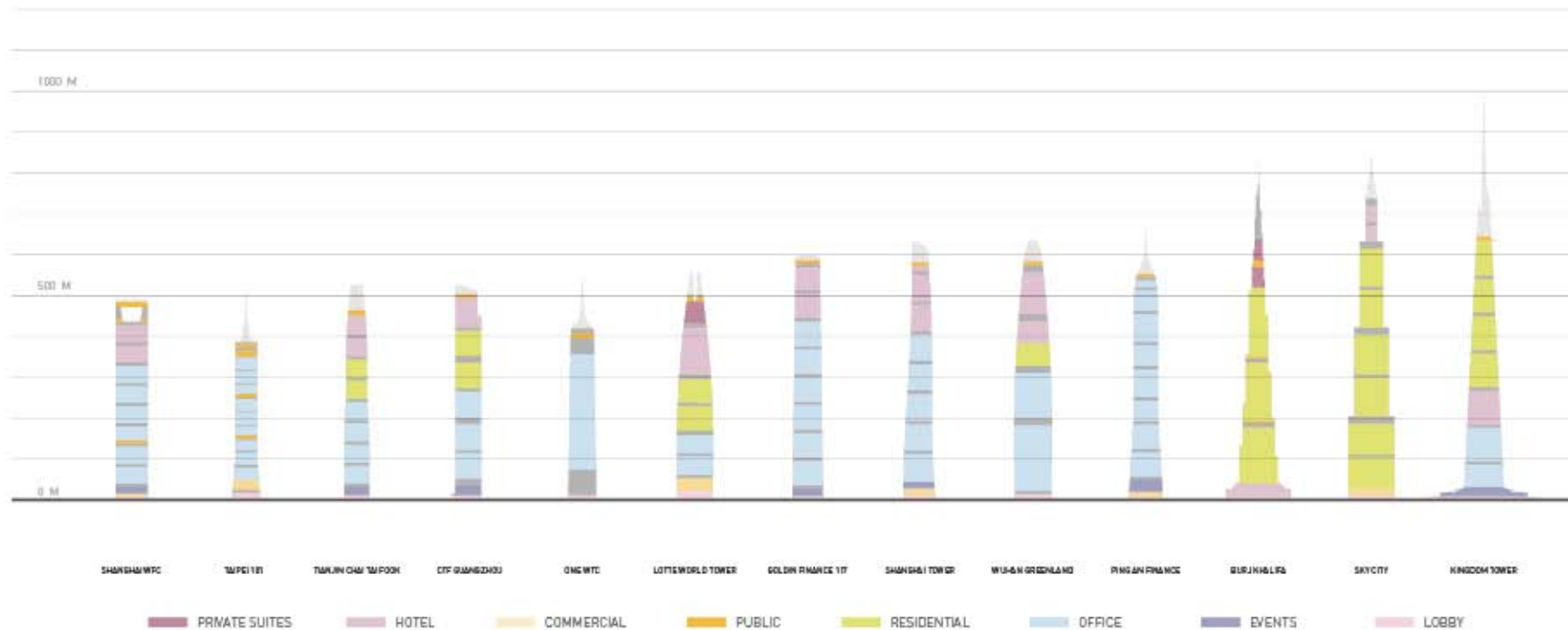
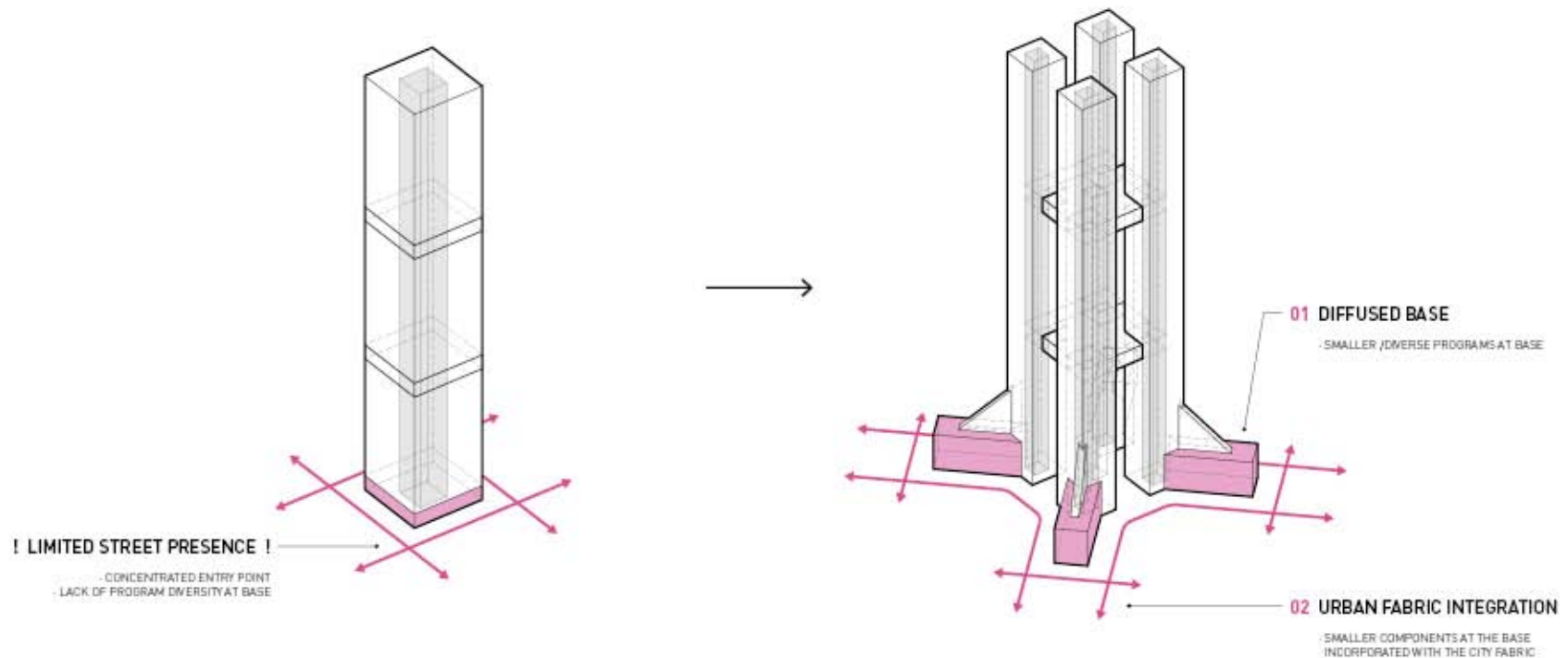

Fig. 65 Diagrams in elevation, showing the program stacking and distribution of the tallest 13 building by the year 2020 (CTBUH, 2013).

As the building gets taller, so does each program stack. With more floor area and users, it becomes increasingly more important to distribute the program stack in a more appropriate scale and order.



FLOW OF PROGRAM (2 of 2) : **DIFFUSED BASE**

Diffuse the base of skyscraper, for more distributed entry. More surface area along the street also improves its integration to the urban fabric.

Modern supertall skyscrapers are rarely found tightly packed into an existing urban fabric. Proportionally, the area of entry of a skyscraper is tiny compared to the overall size and height of the building. Because all users of a skyscraper enter the building from the first few floors, the first few floors

of the skyscraper are all dedicated for entrance lobbies. In order to accommodate the massive amount of people entering and exiting in and out of the building, and onto the ground plane around the building, large plazas and open areas are necessary. Bases of skyscraper are bottlenecks with little

regard for its impact on the surrounding street scape or urban continuity. Instead of a nodal presences on the street level, the physical diffusion of the base could improve not only its structural stability, but also its integration with the urban fabric.

INTENTIONALLY LEFT BLANK

INTENTIONALLY LEFT BLANK

3

PROJECT PARAMETERS & TARGETS

The strategies researched and explored in the previous section will be tested through the design of a mile high tower. Designing at such extreme height will reveal both the limits and opportunities of the research. Recent trends also show that the idea of a mile high tower is not a question of if, but when.

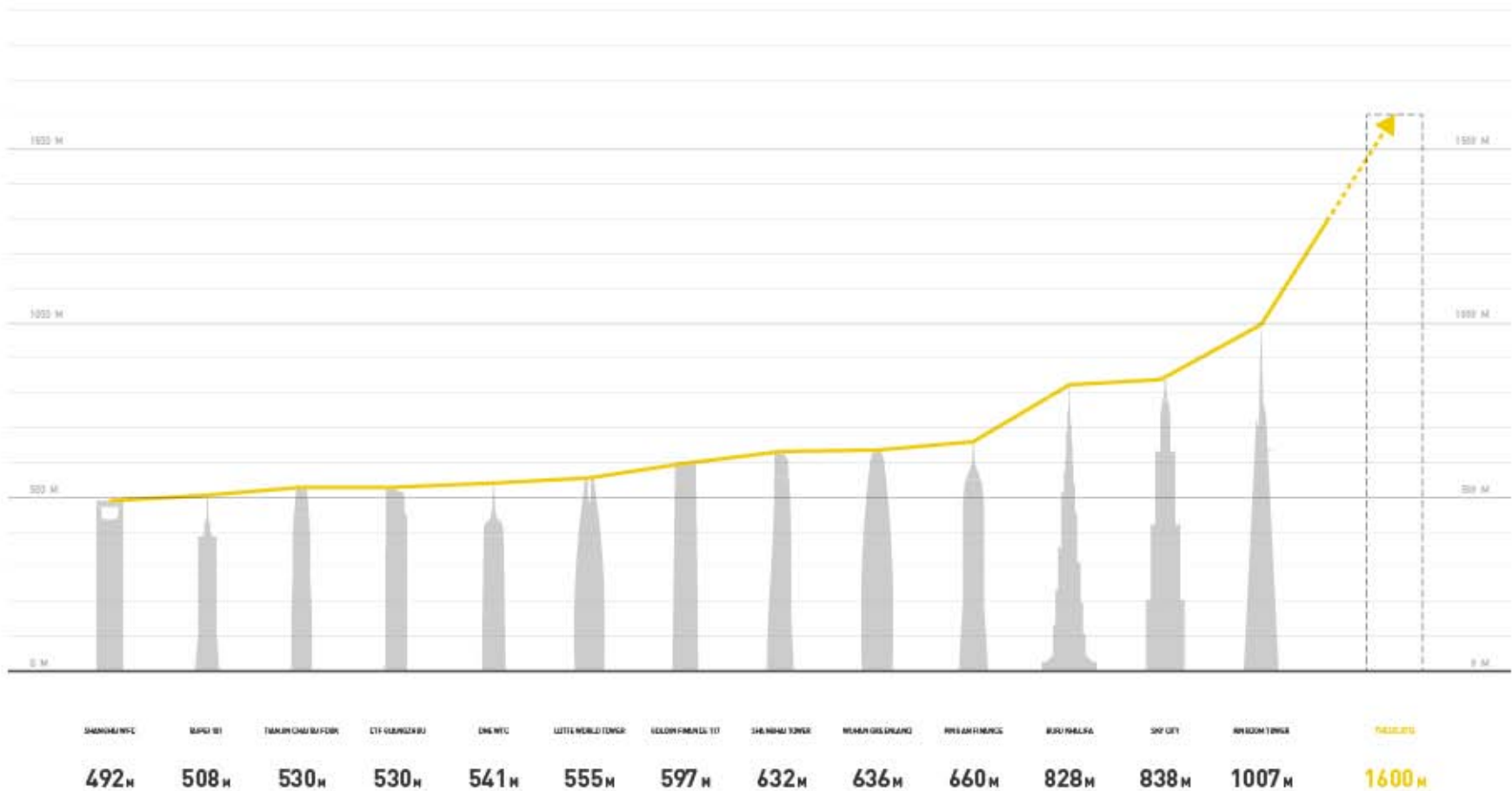

Fig. 66 Total physical height of the 13 tallest buildings by year 2020 (CTBUH, 2013).

Skyscrapers consume an enormous amount of resources for its construction and maintenance. Mounting empty spires for the sake of obtaining the “tallest in the world” status is not only vain, but also glaringly irresponsible in an age of sustainability. The proposed tower will have target vanity height of less than five percent of its entire height.

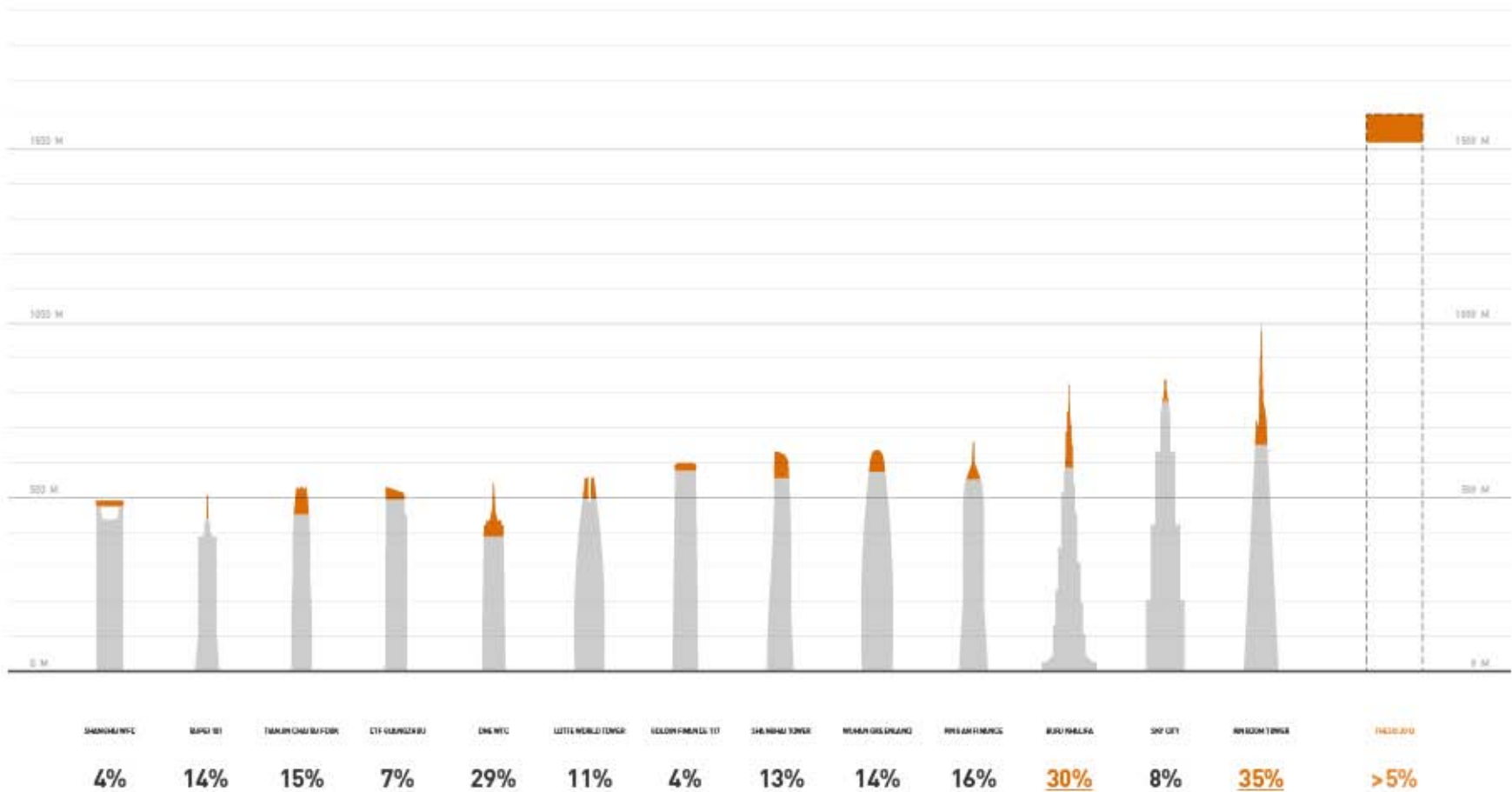

Fig. 67 Total vanity height of the 13 tallest buildings by year 2020 (CTBUH, 2013).

Target FAR (Floor Area Ratio) will be somewhere between 90 and 100. Actual FAR depend on local site conditions and regulations, and is an educated estimation for this project. It is used as a design guide to determine the approximate volume of the entire project, and is not necessarily an accurate constraint.

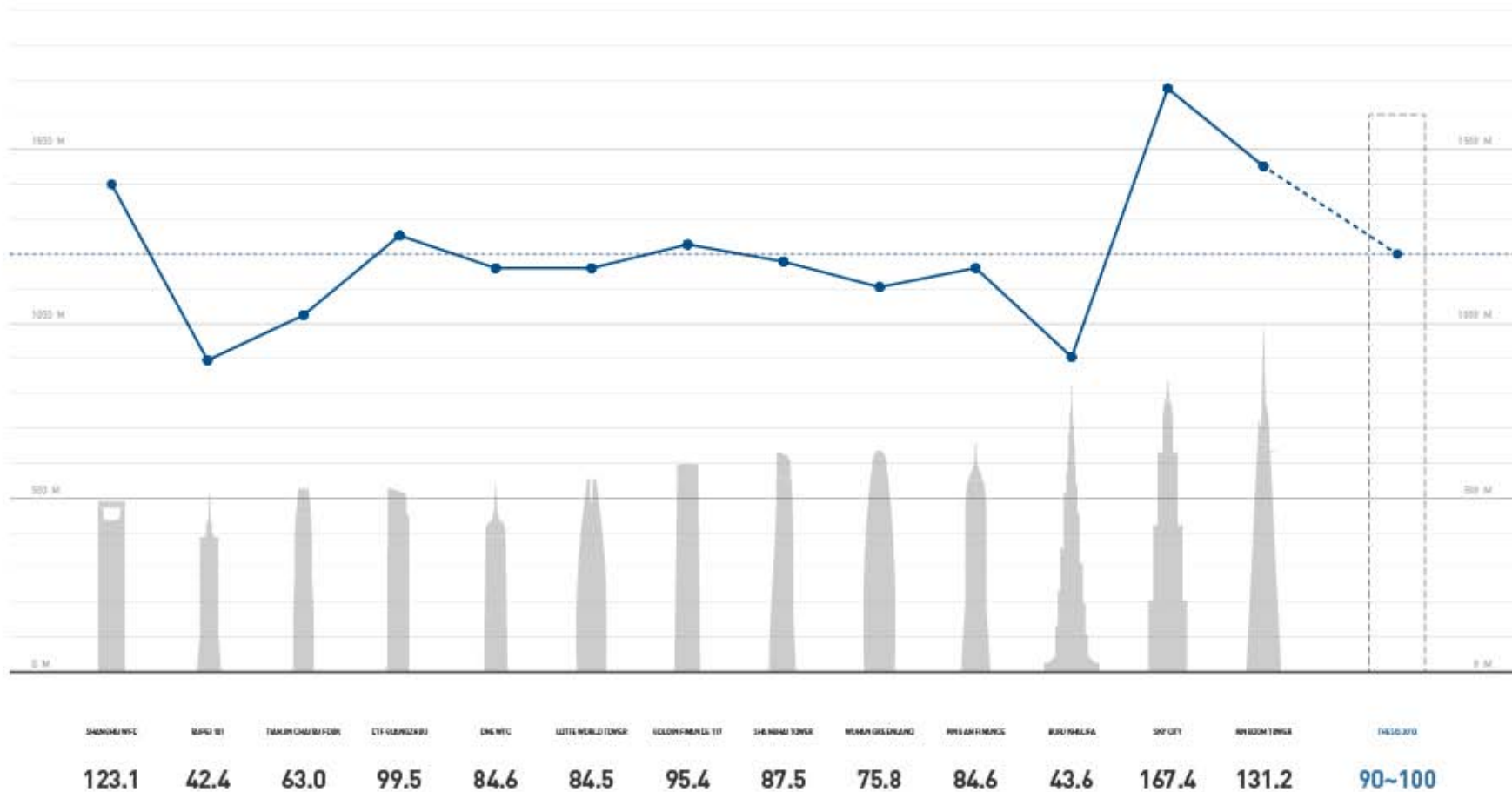

Fig. 68 Total FAR of the 13 tallest buildings by year 2020 (CTBUH, 2013).

Skyscrapers of such extreme heights are possible only in specific geographic locations with social, economic and cultural atmosphere to accommodate them. With the 2022 World Cup scheduled to be held in Qatar, what is already a booming real estate market will see an even more explosive of a growth over the next decade, and mega-construction projects in that country will be imminent.

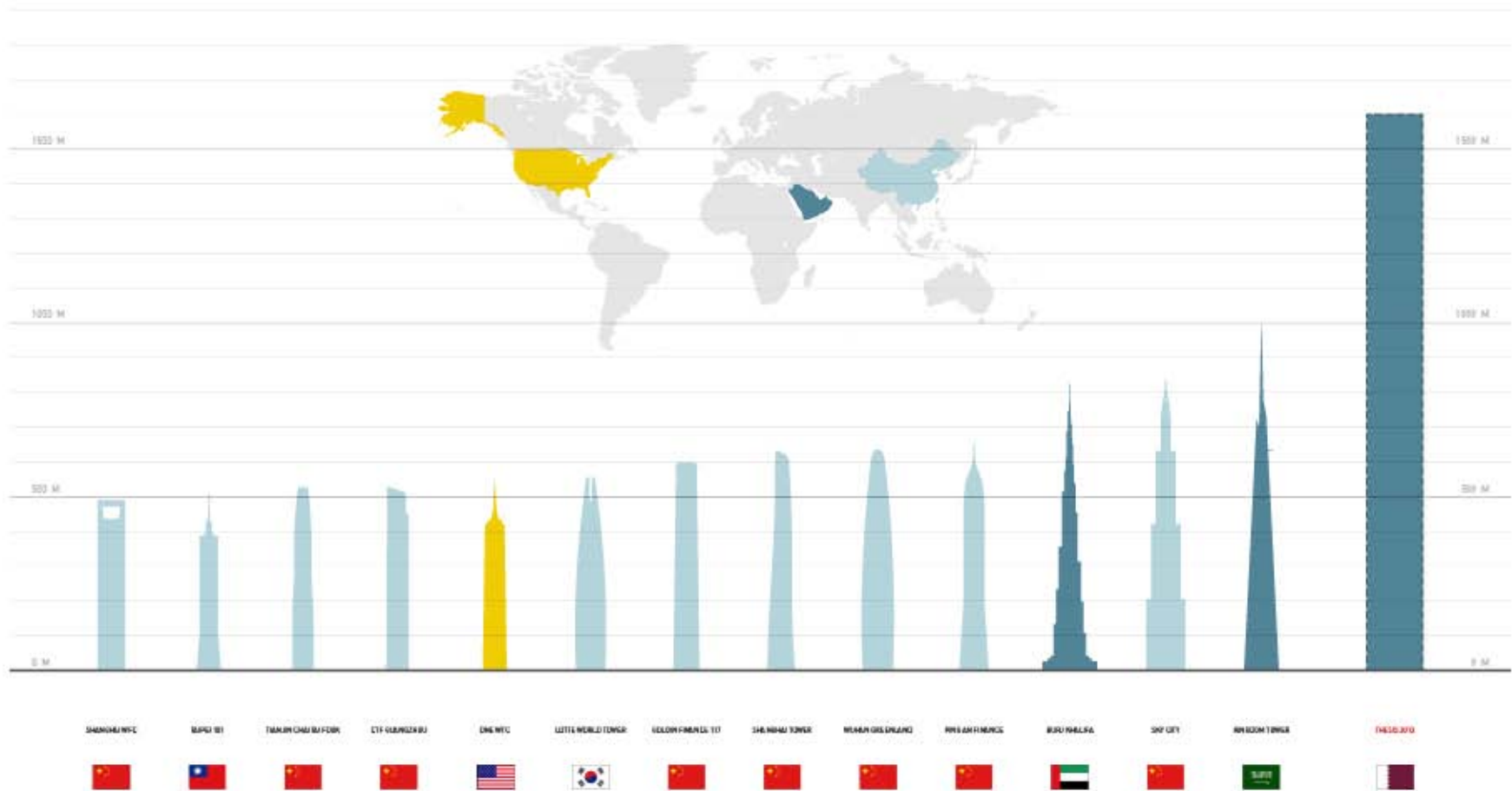

Fig. 69 Location of the 13 tallest buildings by year 2020 (CTBUH, 2013).



Fig. 70 City of Doha, Qatar. (Google Earth, 2013)



Fig. 71 Lusail City Development, Doha, Qatar (Lusail Real Estate Development Company, 2013)

INTENTIONALLY LEFT BLANK

INTENTIONALLY LEFT BLANK

4

DESIGN PROJECT

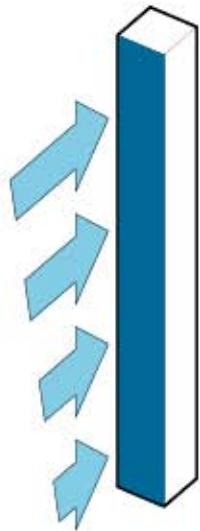

01 WIND LOADING AND THE EXPOSURE SURFACE

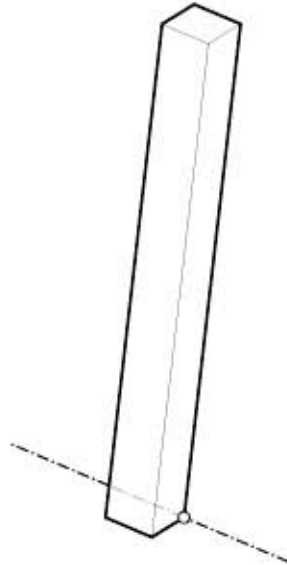

02 OVERTURNING MOMENT WILL FORCE THE TOWER TO TIP OVER AROUND

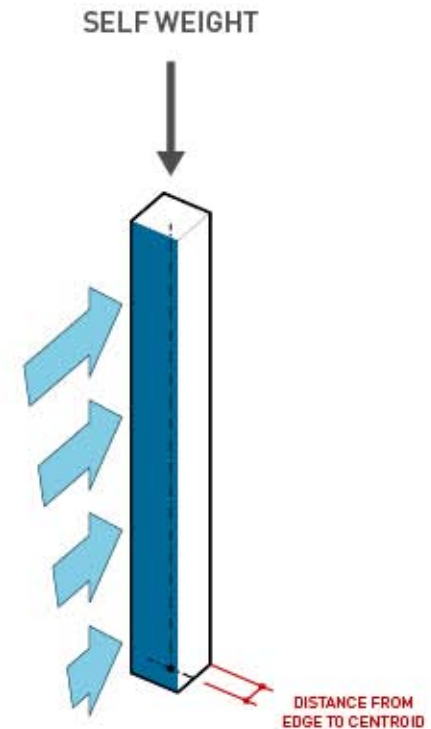

03 SELF WEIGHT WILL RESIST THE OVERTURNING

Skyscraper's overall proportion, and the dimensional relationship between its height, base size and its resultant volume, determine its basic stability under lateral loads.



04 SUBDIVIDE THE TOWER INTO BLOCKS TO ANALYZE USING JUST SELF WEIGHT AND LATERAL LOADS

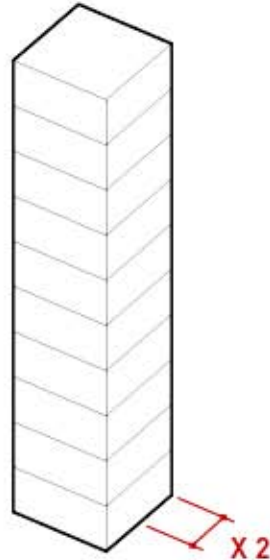

05 OPTION A: WIDER FOOTPRINT, MORE SELF WEIGHT AND LARGER MOMENT ARM

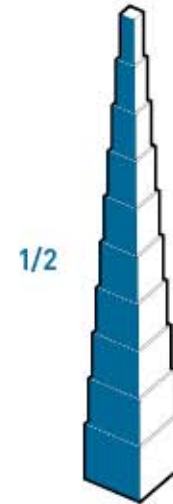

06 OPTION B: TAPERED MASSING TO REDUCE WIND EXPOSURE

Form is directly related to its stability. It is a function of its height, base, self weight, and exposed surface of each subdivided block. With a form that changes in elevation, the shape of the pieces above it also has an effect on the piece above and below it.

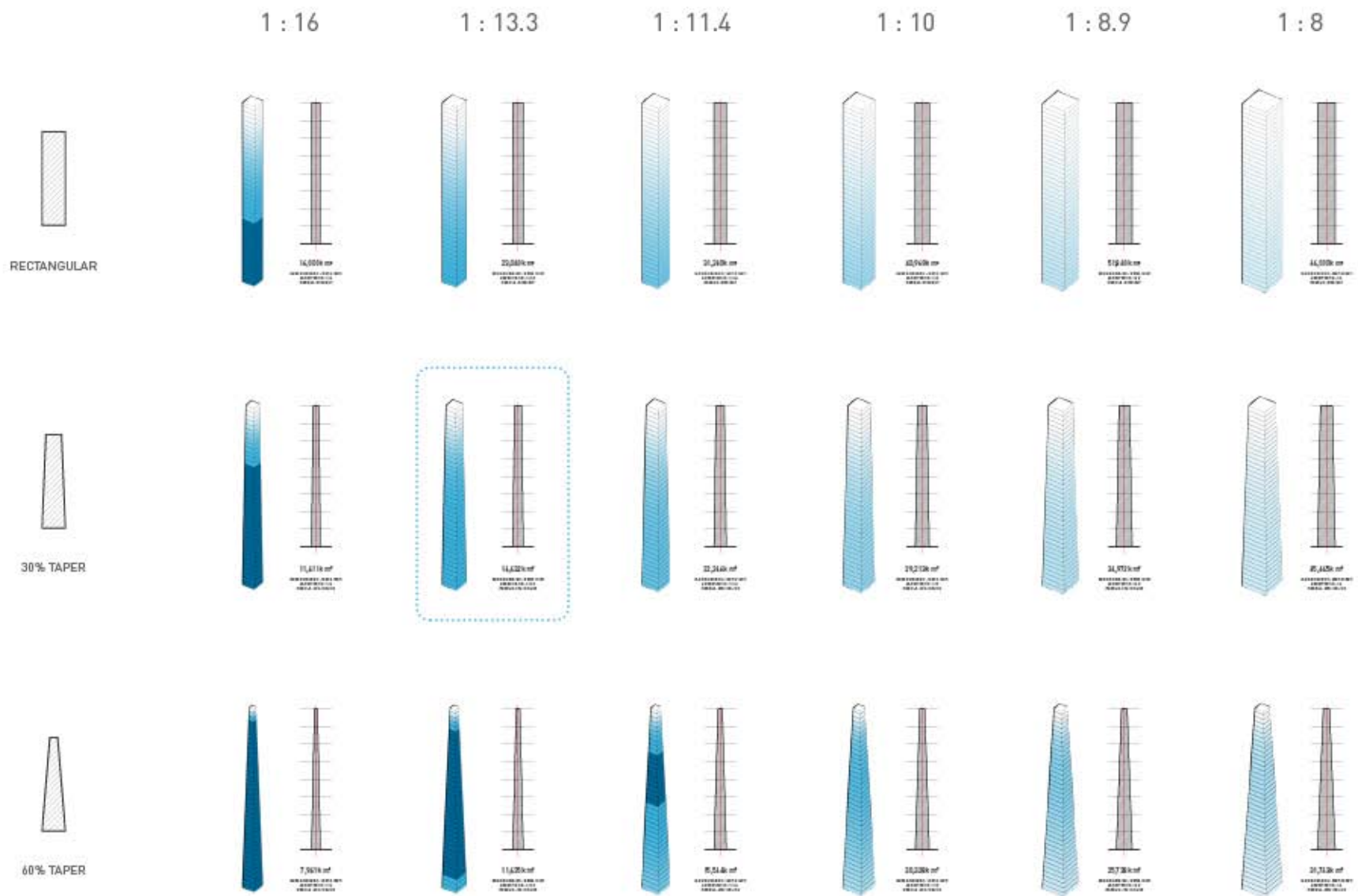

Fig. 72 Parametric analysis (Part 1) of various forms using Grasshopper. White means the block is stable. Darker the blue, more unstable it is.

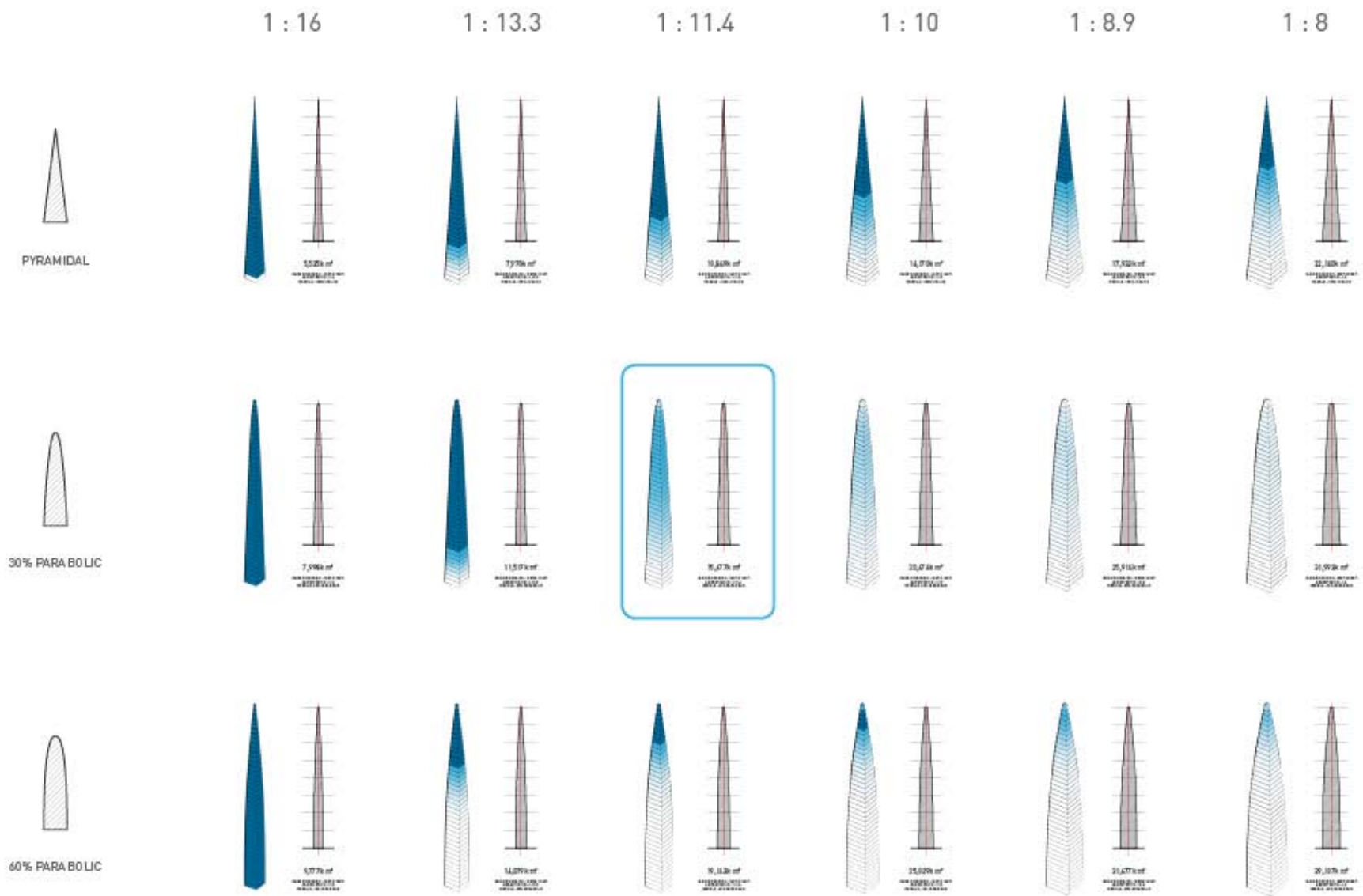

Fig. 73 Parametric analysis (Part 2) of various forms using Grasshopper. White means the block is stable. Darker the blue, more unstable it is.

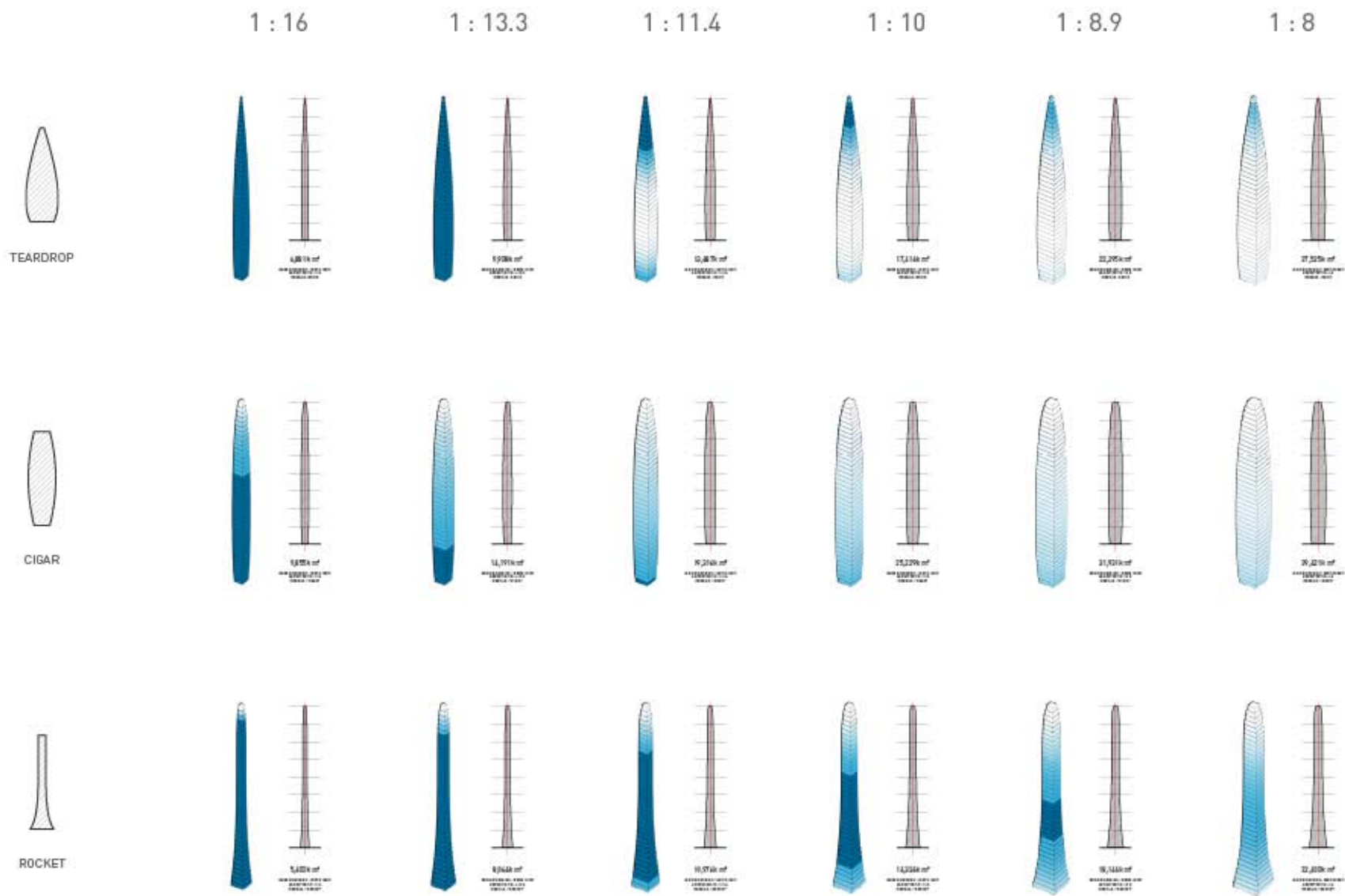

Fig. 74 Parametric analysis (Part 3) of various forms using Grasshopper. White means the block is stable. Darker the blue, more unstable it is.

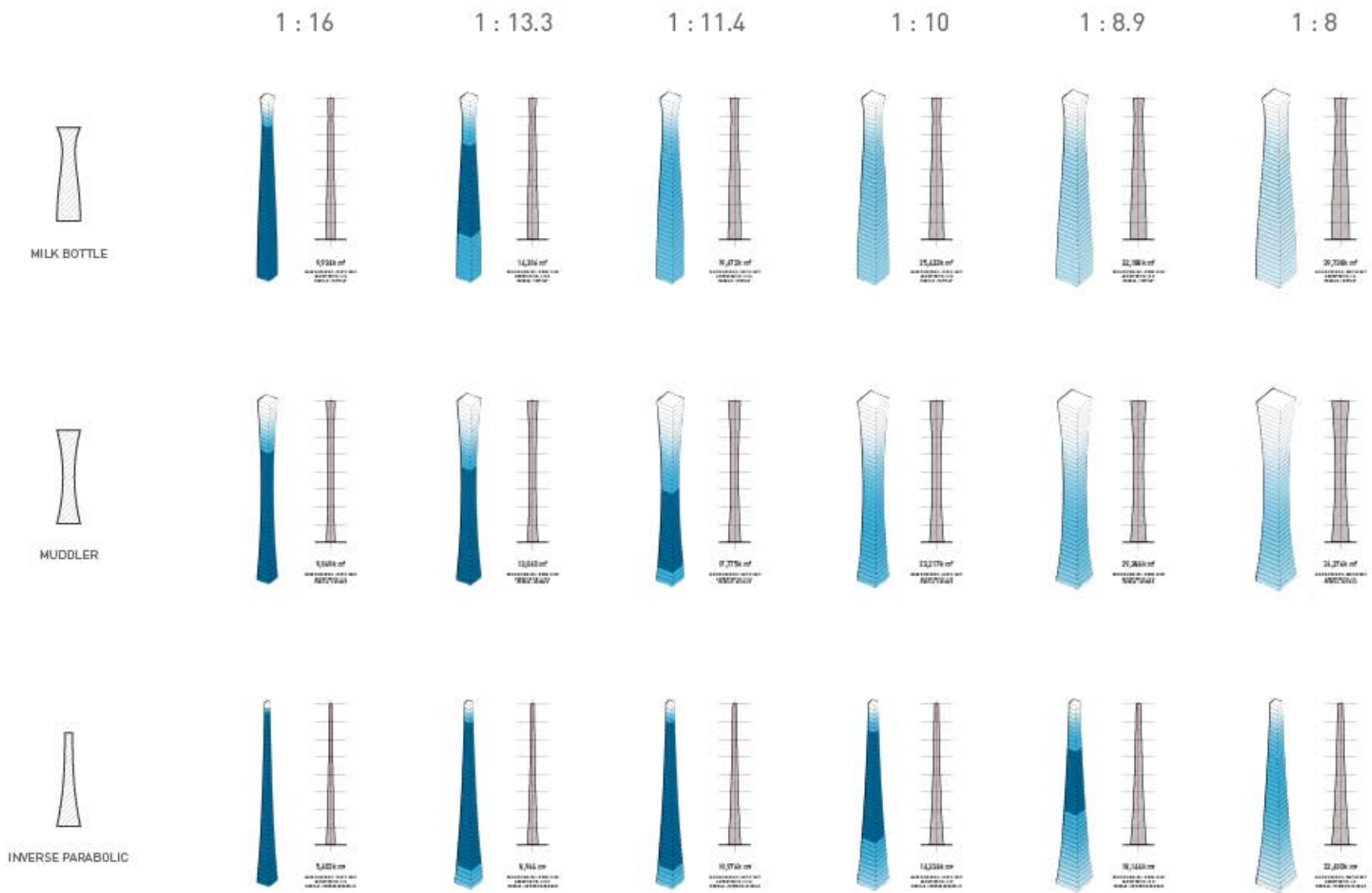
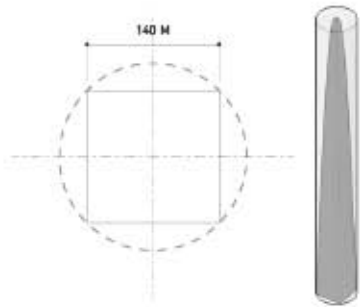

Fig. 75 Parametric analysis (Part 4) of various forms using Grasshopper. White means the block is stable. Darker the blue, more unstable it is.

01 IDEAL SLENDERNESS & ASPECT RATIO

VOLUME : 15,663,420 m³
PERIMETER SURFACE : 603,033 m²



02 MAXIMUM VOLUME = MAXIMUM AREA

VOLUME : 50,265,483 m³
PERIMETER SURFACE : 1,005,310 m²

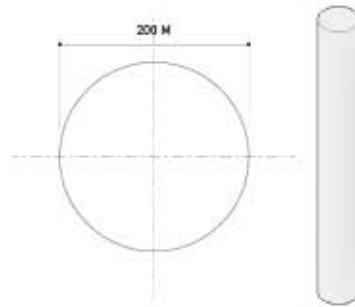

03 SINGLE / CENTRAL CORE = DEEP FLOOR PLATES

VOLUME : 50,265,483 m³
PERIMETER SURFACE : 1,005,310 m²

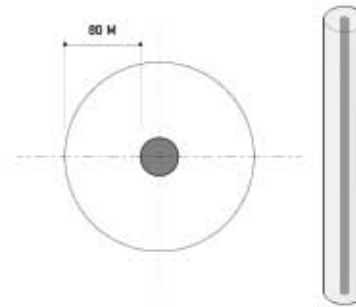

04 LARGE ATRIUM = INEFFICIENT FLOORS

VOLUME : 13,948,472 m³
PERIMETER SURFACE : 1,859,823 m²

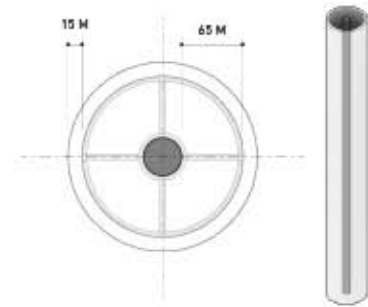

05 CYLINDRICAL CORE = UNUSABLE INTERIOR

VOLUME : 2,123,140 m³
PERIMETER SURFACE : 1,749,345 m²

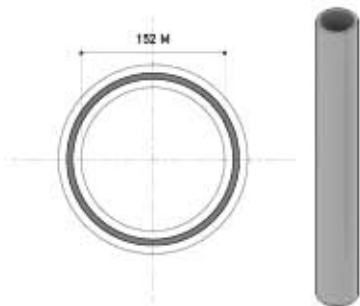

06 RADIAL / SPLIT CORE = MORE EFFICIENT

VOLUME : 47,123,890 m³
PERIMETER SURFACE : 1,296,637 m²

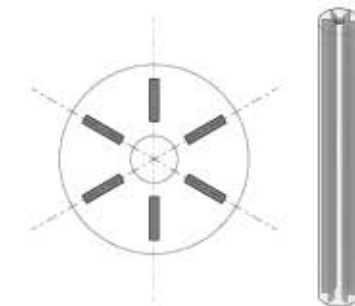

07 OPTIMIZED DOUBLE LOADED CORRIDORS

VOLUME : 27,736,628 m³
PERIMETER SURFACE : 1,883,920 m²

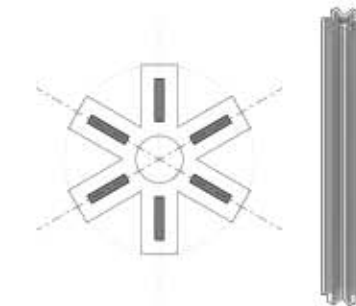

08 VOID CENTER FOR PUBLIC, GAPS FOR THRU-WIND

VOLUME : 17,245,470 m³
PERIMETER SURFACE : 1,437,711 m²

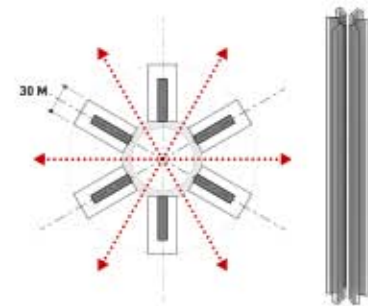

09 STAGGER WING MASSES = PROGRAM VARIETY

VOLUME : 14,941,670 m³
PERIMETER SURFACE : 1,284,111 m²

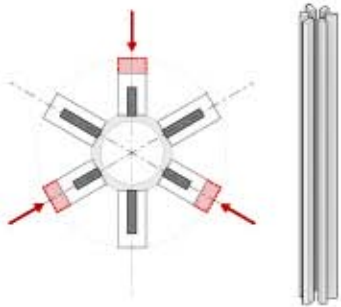

10 TORSION DIAPHRAGMS = PUBLIC "SQUARES"

VOLUME : 18,267,208 m³
PERIMETER SURFACE : 1,284,111 m²

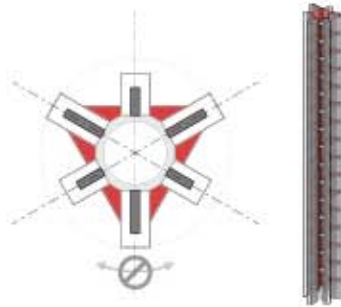

11 DIFFUSED BASE = STREET INTEGRATION

VOLUME : 21,023,702 m³
PERIMETER SURFACE : 1,421,540 m²

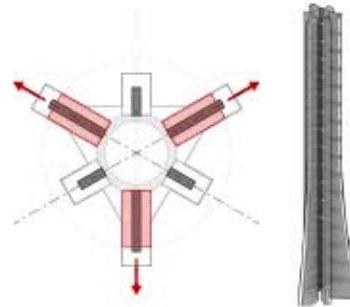

12 SOLID BASE = STABILITY

VOLUME : 24,748,919 m³
PERIMETER SURFACE : 1,885,479 m²

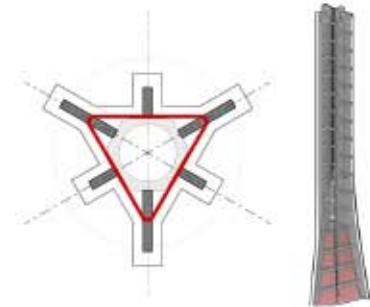

13 CARVE OUT SOUTH FACING MASSES

VOLUME : 15,025,352 m³
PERIMETER SURFACE : 988,552 m²

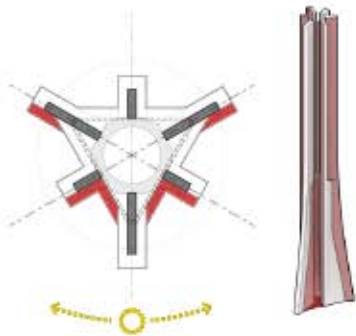

14 "TOP-DOWN" M.E.P. SYSTEMS

VOLUME : 15,025,352 m³
PERIMETER SURFACE : 988,552 m²

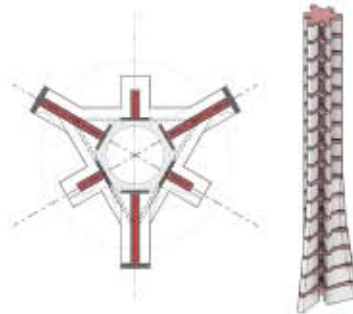

15 USE OF CENTRAL VOID = MAIN CIRCULATION

VOLUME : 15,025,352 m³
PERIMETER SURFACE : 988,552 m²

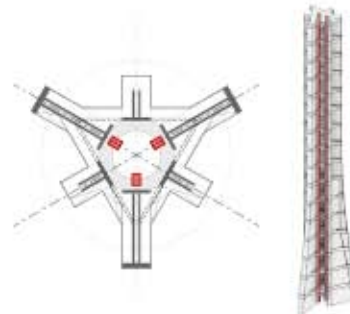

16 USE OF CENTRAL VOID = SOLAR UPDRAFT TOWER

VOLUME : 15,025,352 m³
PERIMETER SURFACE : 988,552 m²

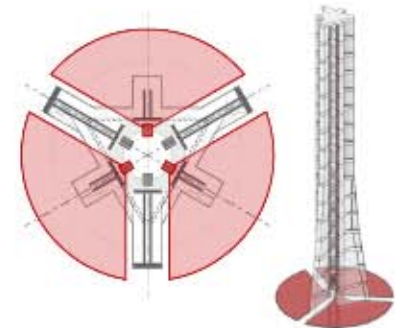

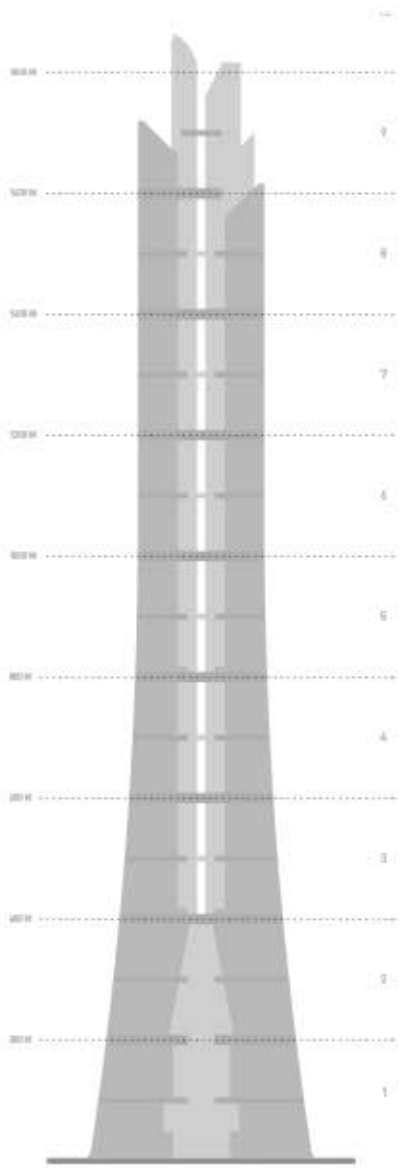

01 BASE MASSING

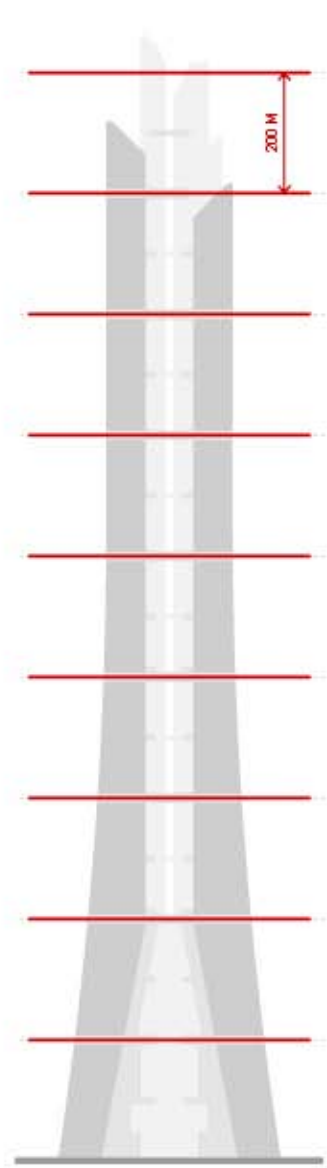

02 200m SUBDIVISIONS

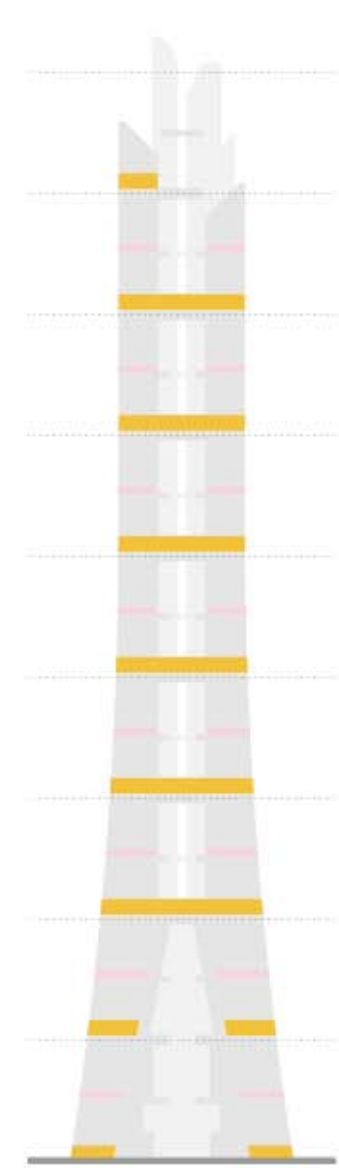

03 PUBLIC PLAZA LEVELS

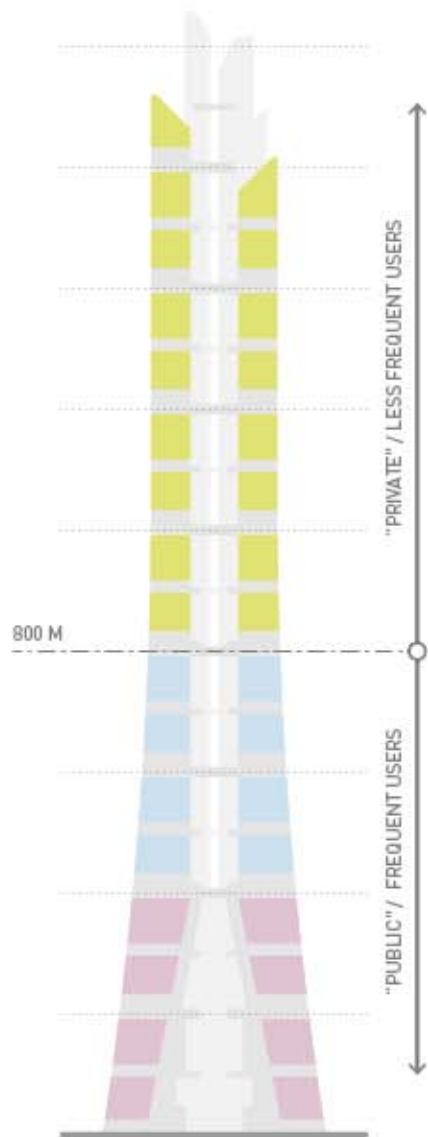

04 GENERAL PROGRAM ORGANIZATION

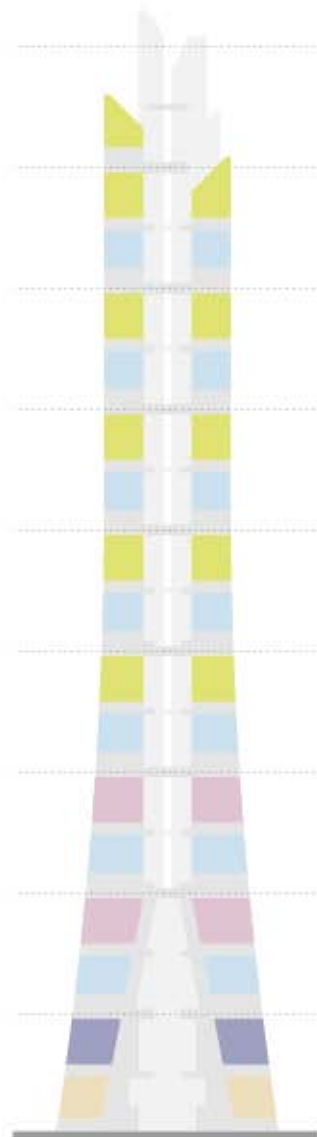

05 SUBDIVIDED STACKING

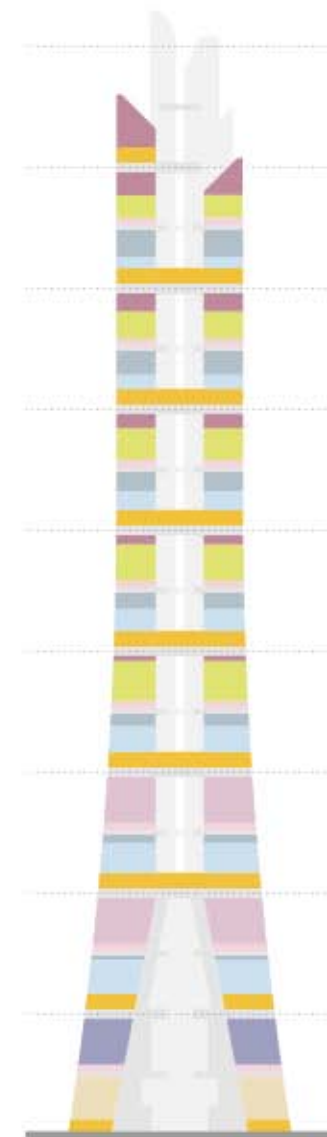

06 PROGRAM REFINEMENT

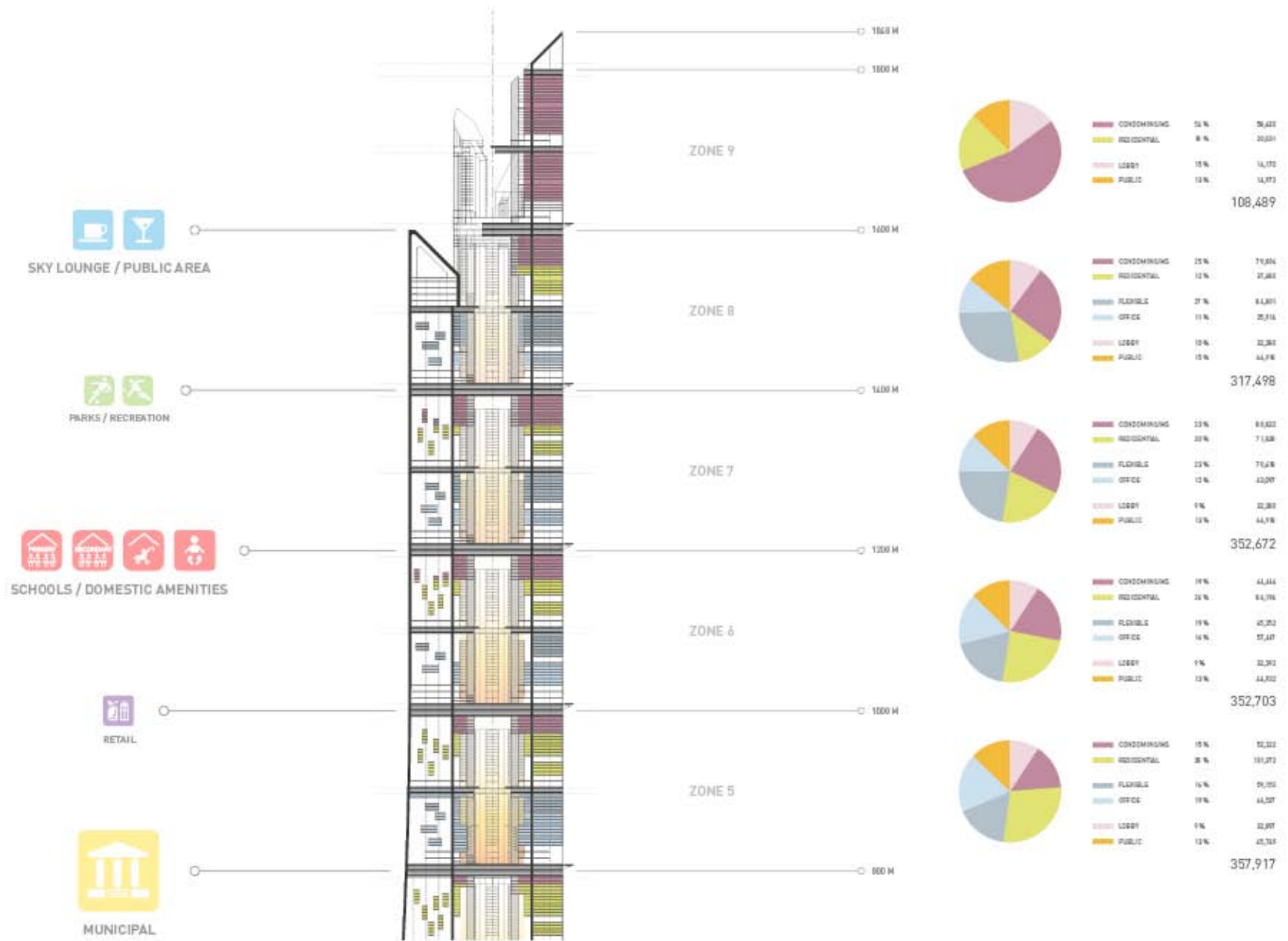

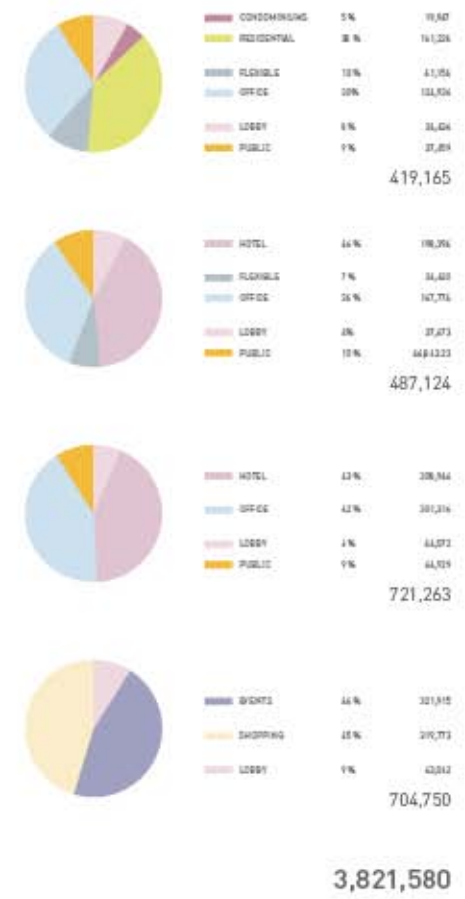
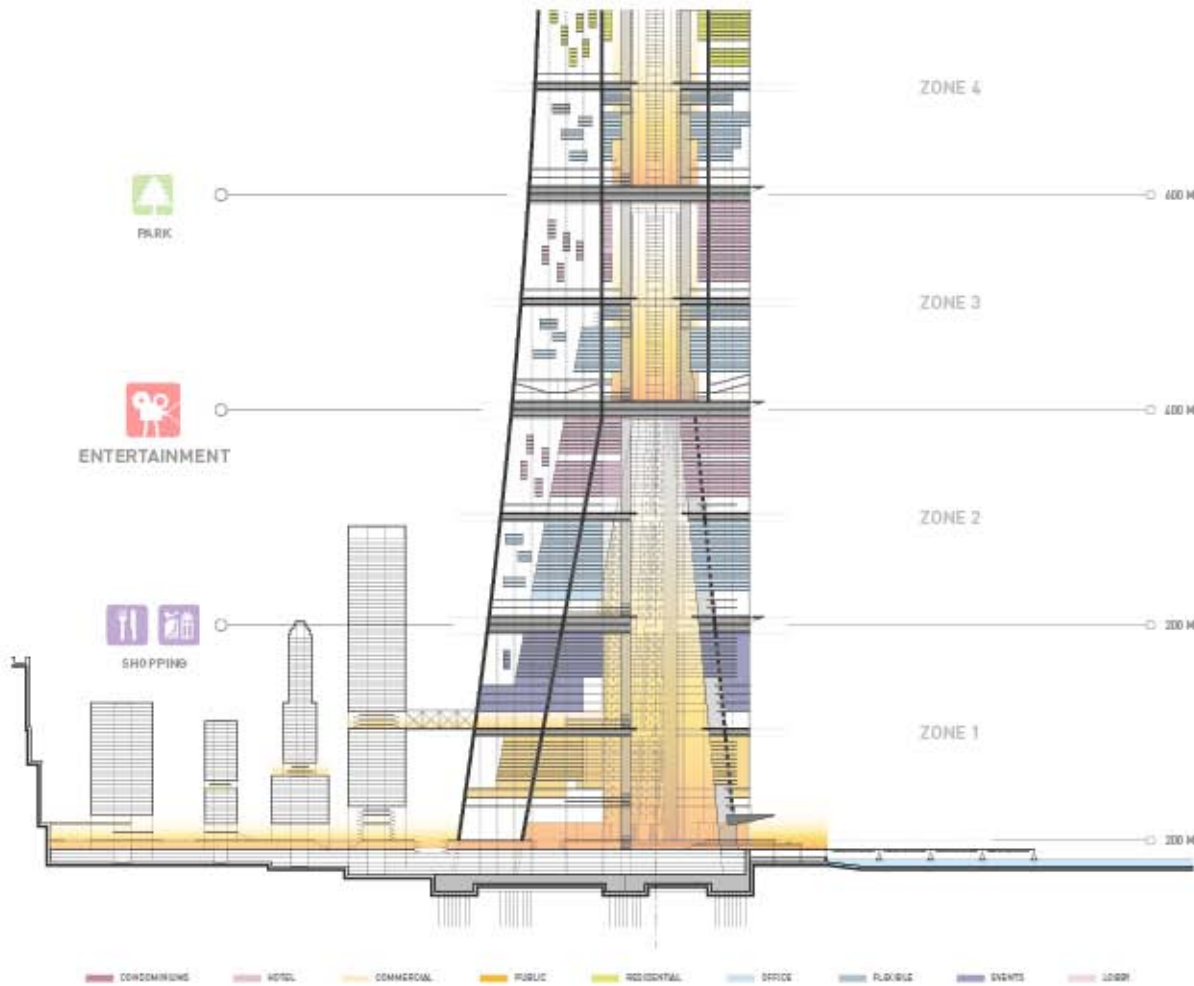

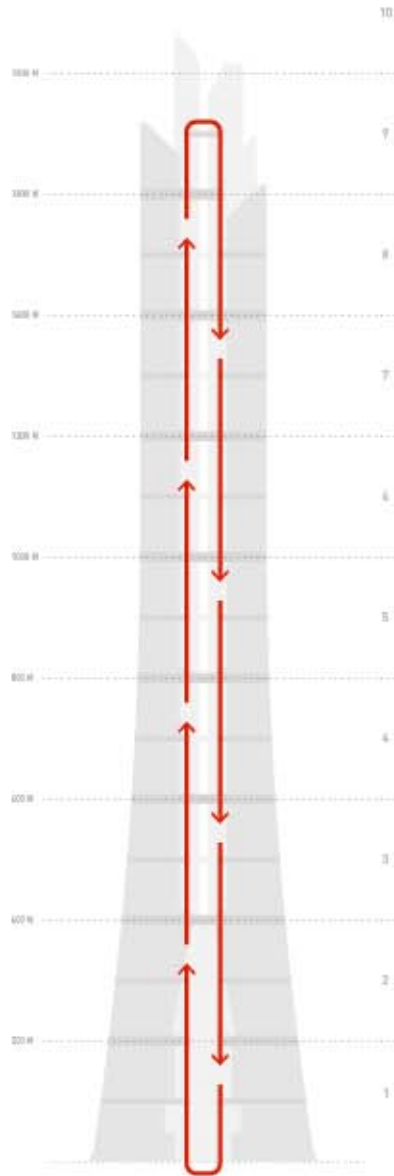
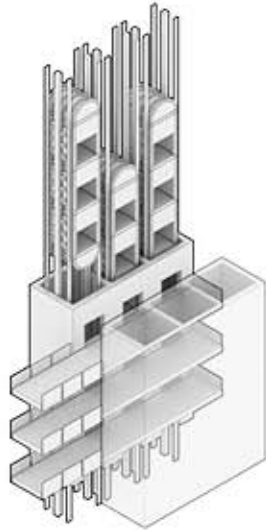

“BOULEVARDS” - 3 DECK, MAGNETIC / CYCLICAL ELEVATORS

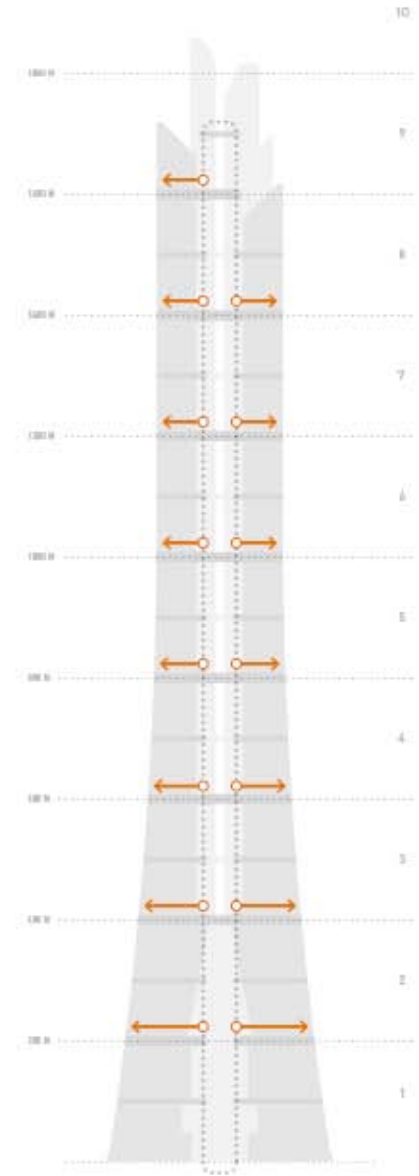

“PLAZAS” - PUBLIC TRANSFER PLATFORM LEVELS

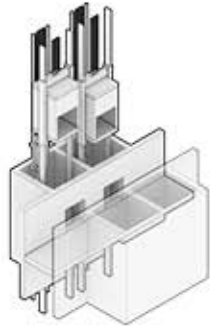

"ALLEYS" - LOCAL ELEVATORS

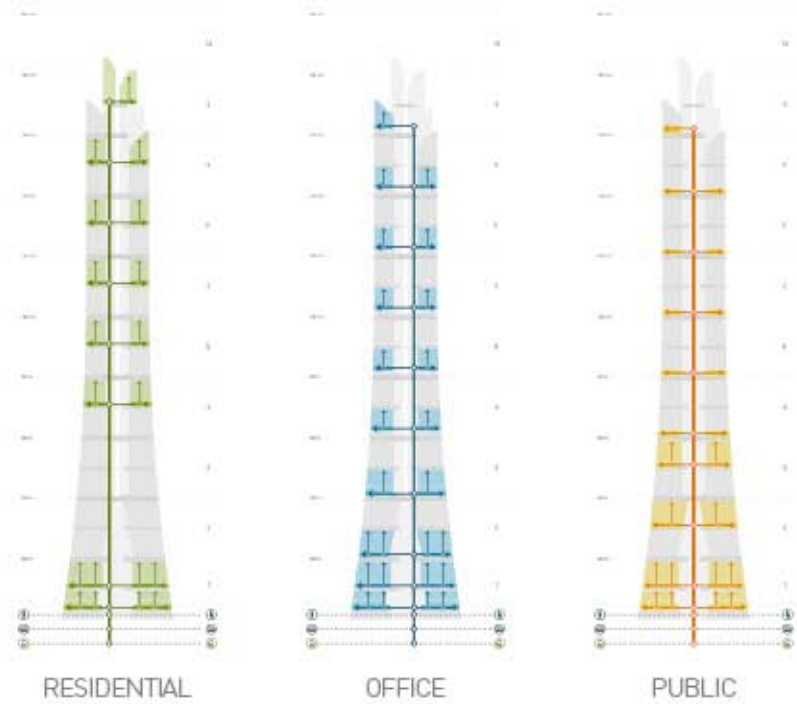

MULTIPLE CORES, EACH DEDICATED TO A USER TYPE

TYPICAL BASE



EXPRESS CORES : 3
EXPRESS (3-DECK) ELEVATORS : 18



LOCAL CORES : 6
LOCAL ELEVATORS : 54

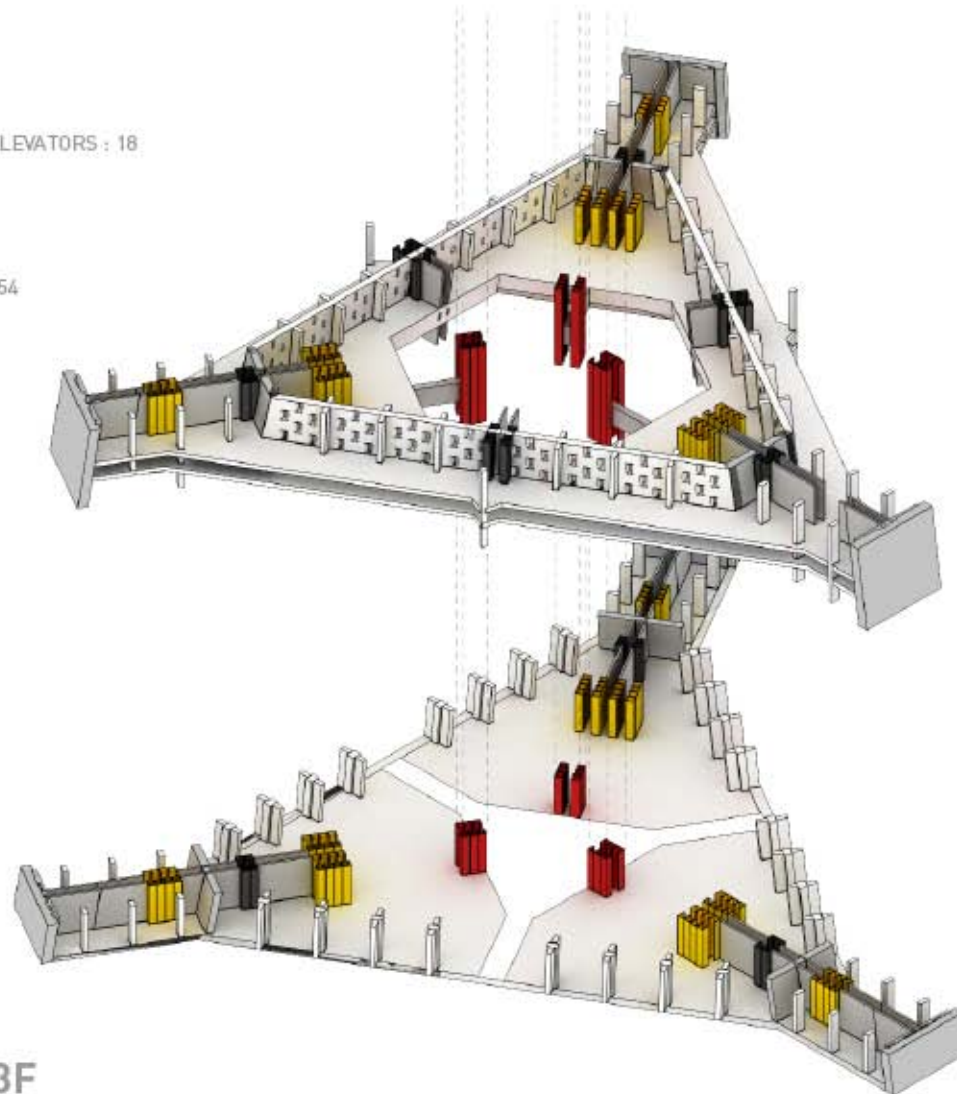

LEVELS 1F - 33F

TYPICAL LOW RISE



EXPRESS CORES : 3
EXPRESS (3-DECK) ELEVATORS : 18



LOCAL CORES : 3
LOCAL ELEVATORS : 36

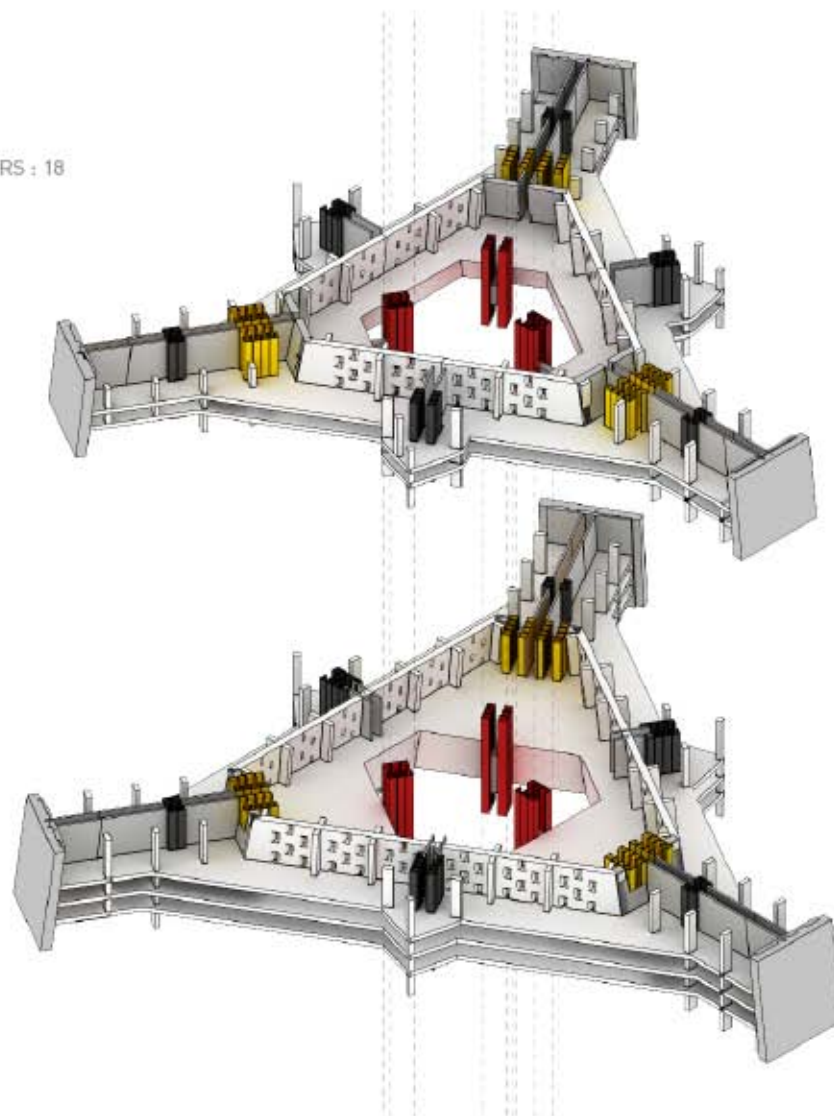

LEVELS 34F - 72F

TYPICAL MID RISE



EXPRESS CORES : 3
EXPRESS (3-DECK) ELEVATORS : 18



LOCAL CORES : 6
LOCAL ELEVATORS : 36

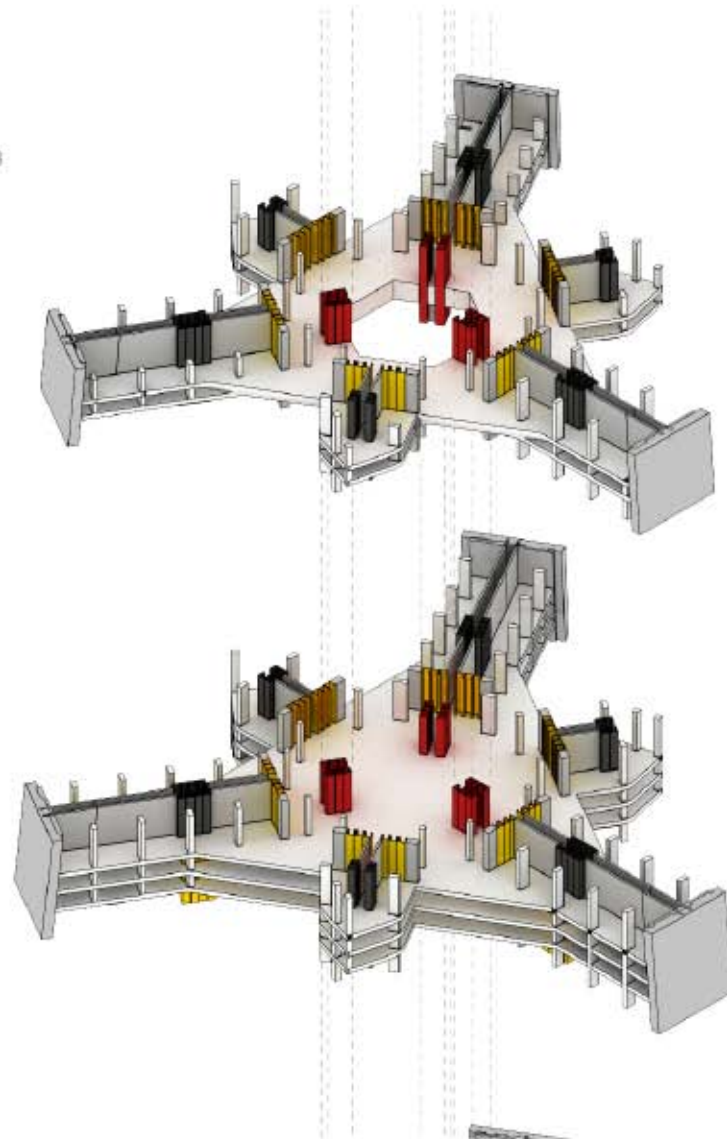

LEVELS 73F - 150F

TYPICAL HIGH RISE



EXPRESS CORES : 3
EXPRESS (3-DECK) ELEVATORS : 18



LOCAL CORES : 6
LOCAL ELEVATORS : 36

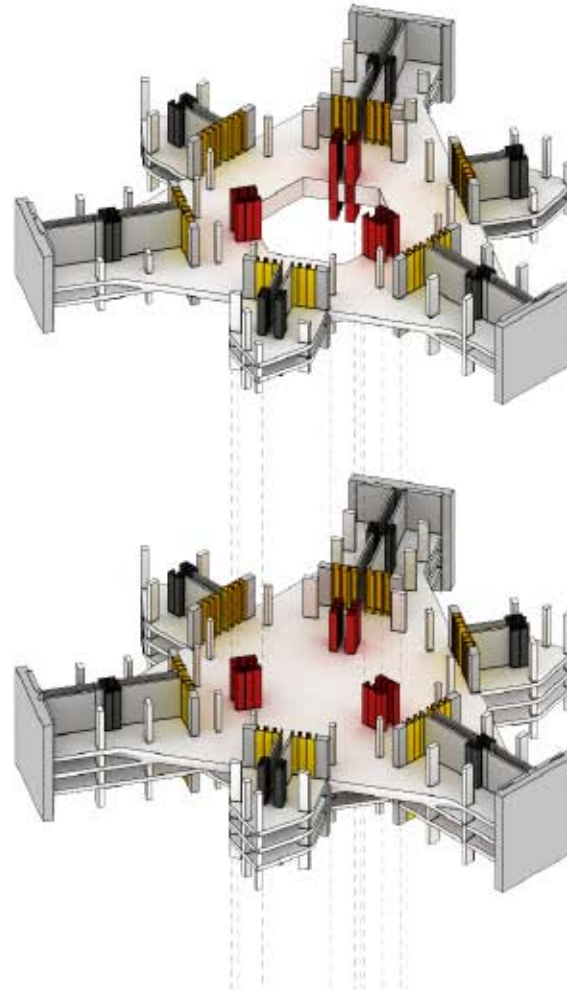

LEVELS 151F - 350F

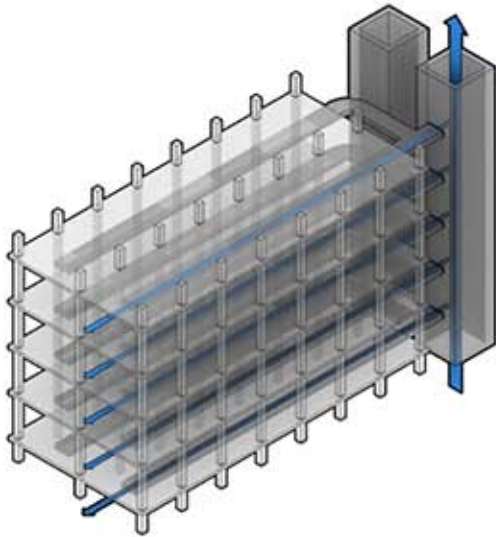

TRADITIONAL SYSTEM: VERTICAL CORE + HORIZONTAL DUCTS

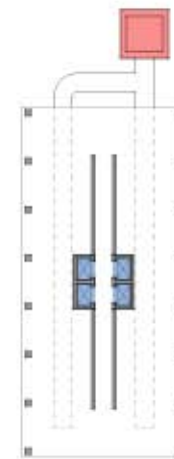
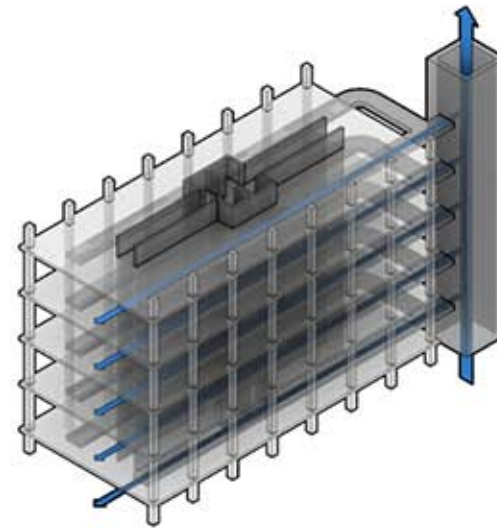

STRUCTURE / ELEVATOR INTEGRATION

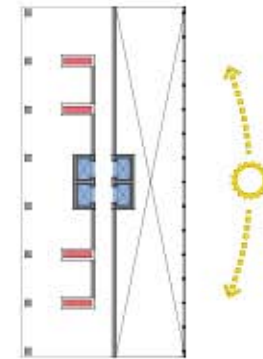
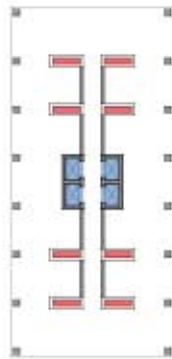
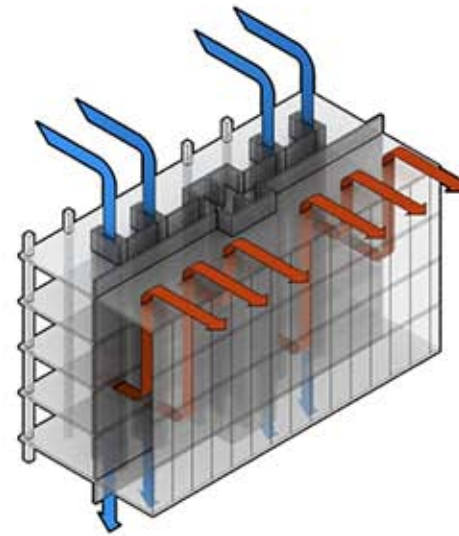
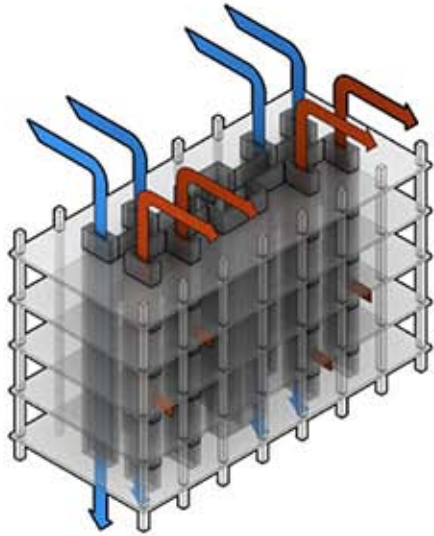

STRUCTURE / ELEVATOR / VERTICAL DUCTS INTEGRATION

OCCUPATION BASED ON ENVIRONMENTAL ORIENTATION

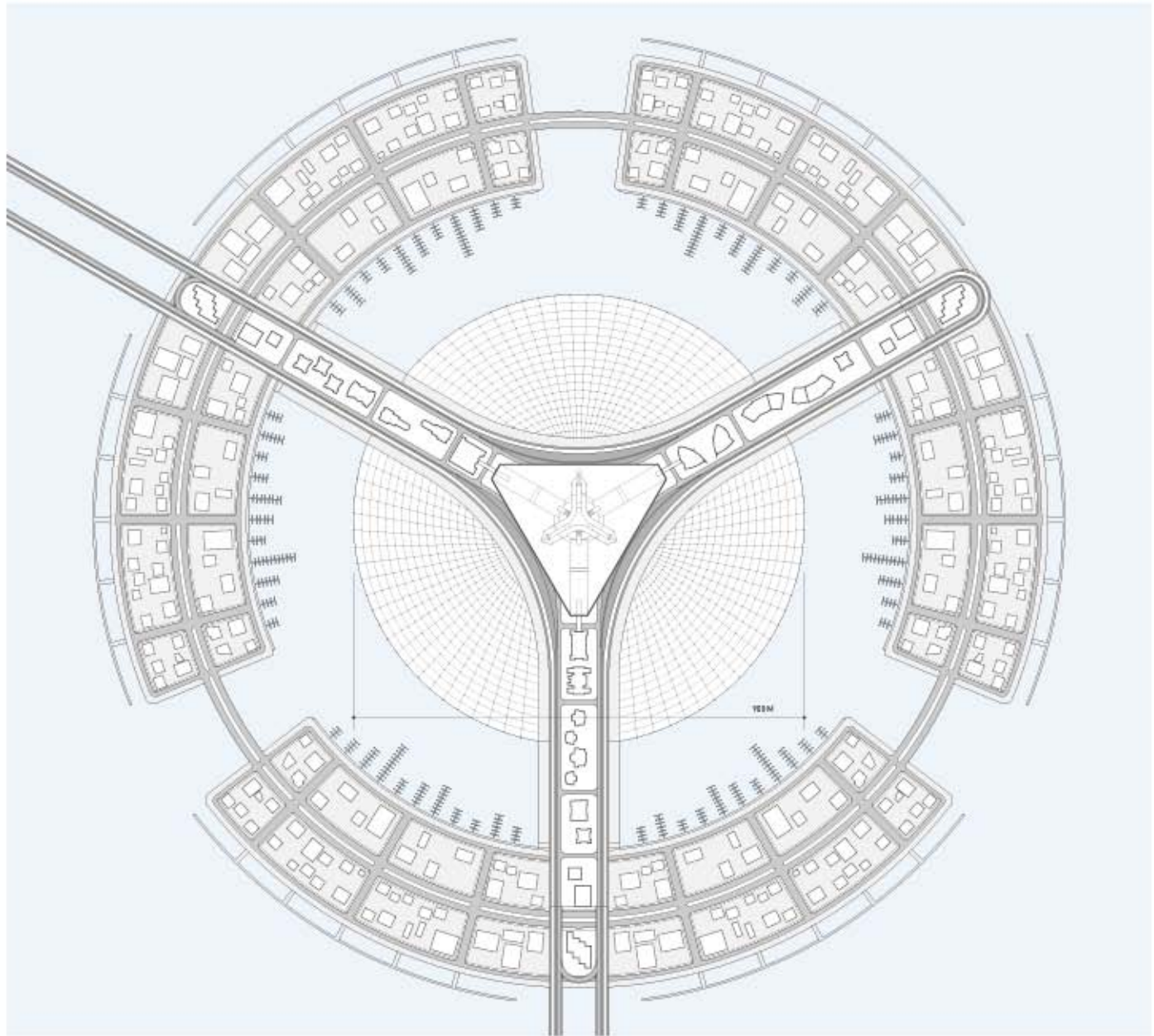

SITE PLAN

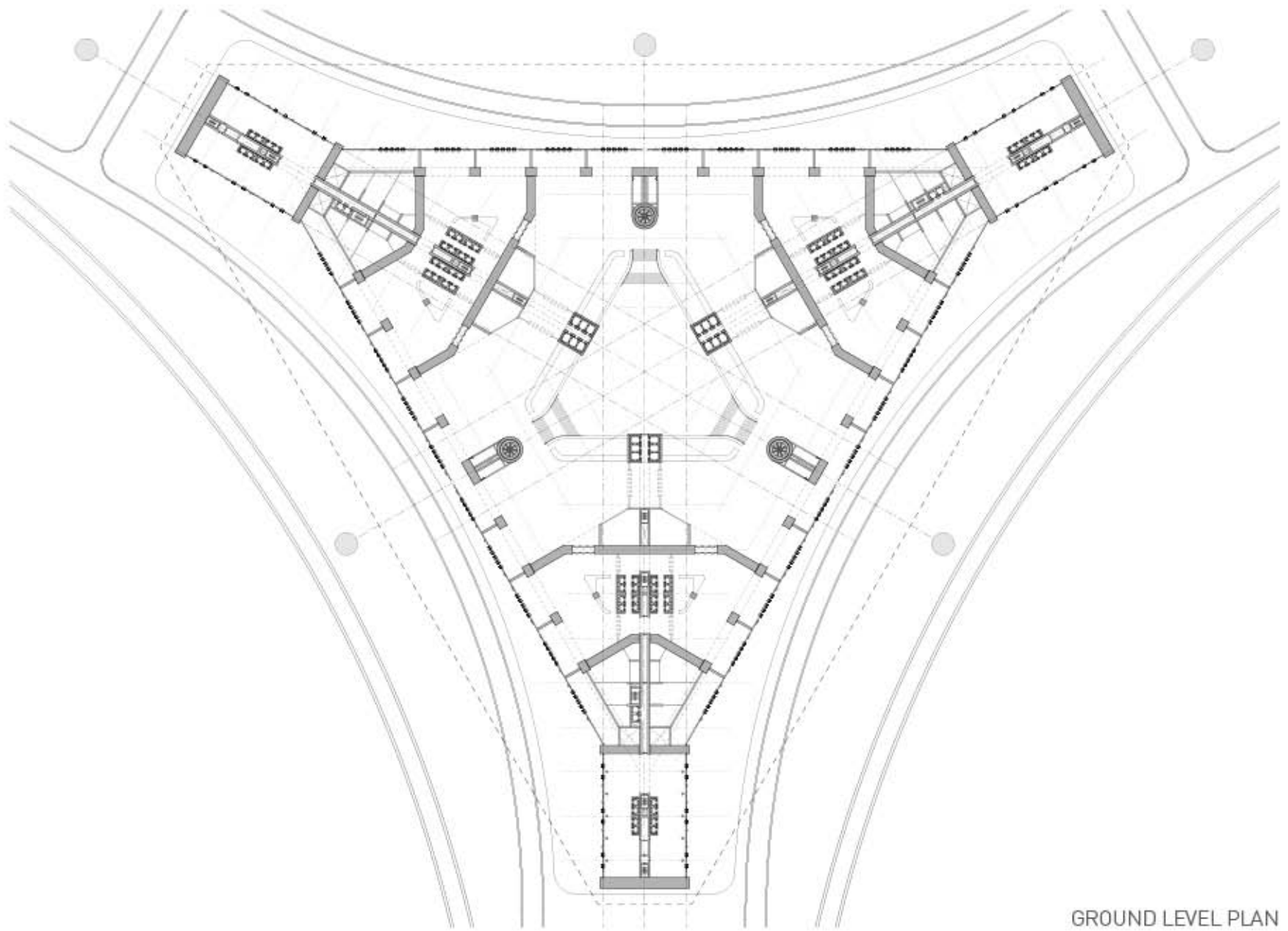

GROUND LEVEL PLAN

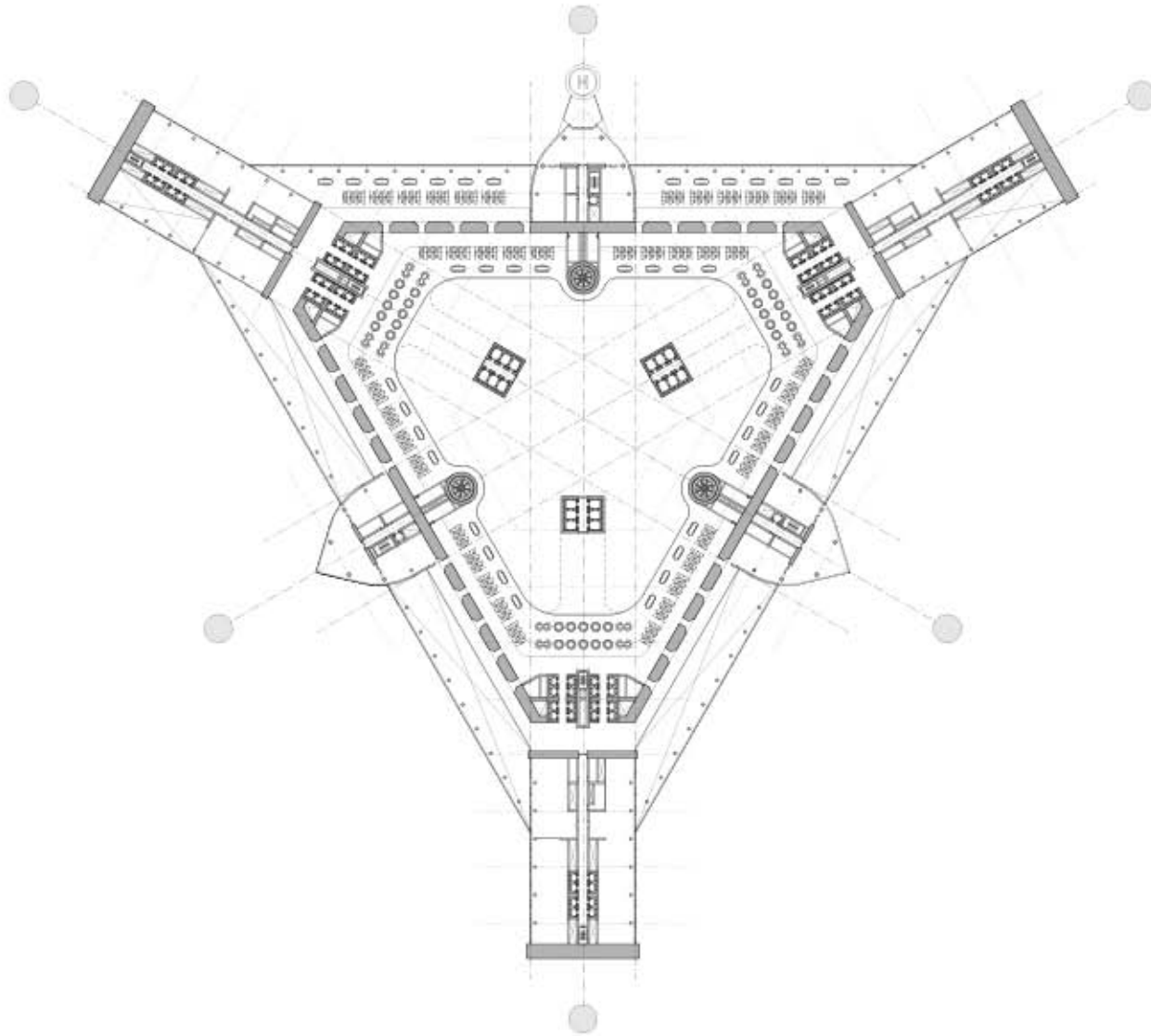

TYPICAL LOW-RISE OFFICE LEVEL

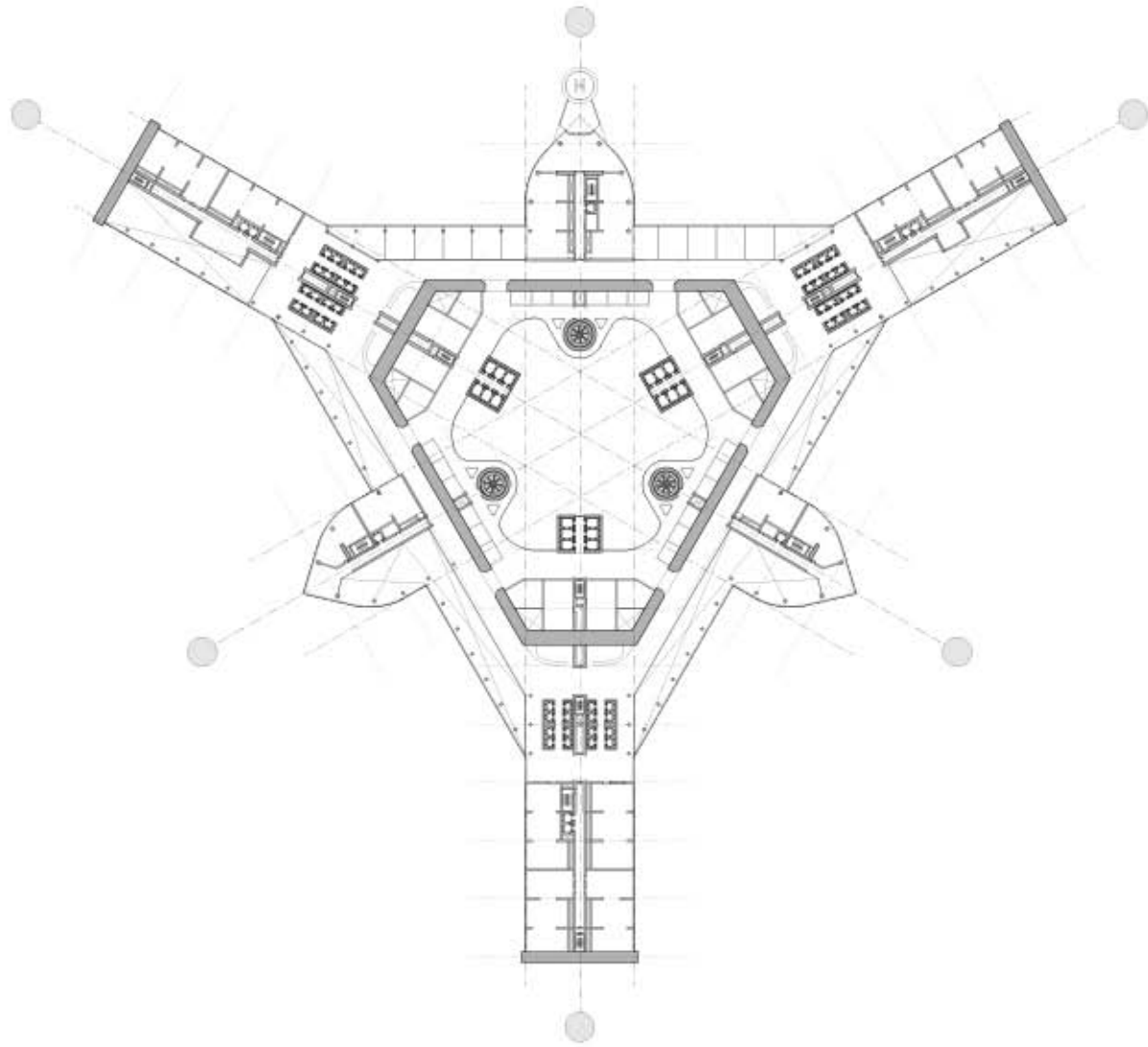

TYPICAL MID-RISE HOTEL LEVEL

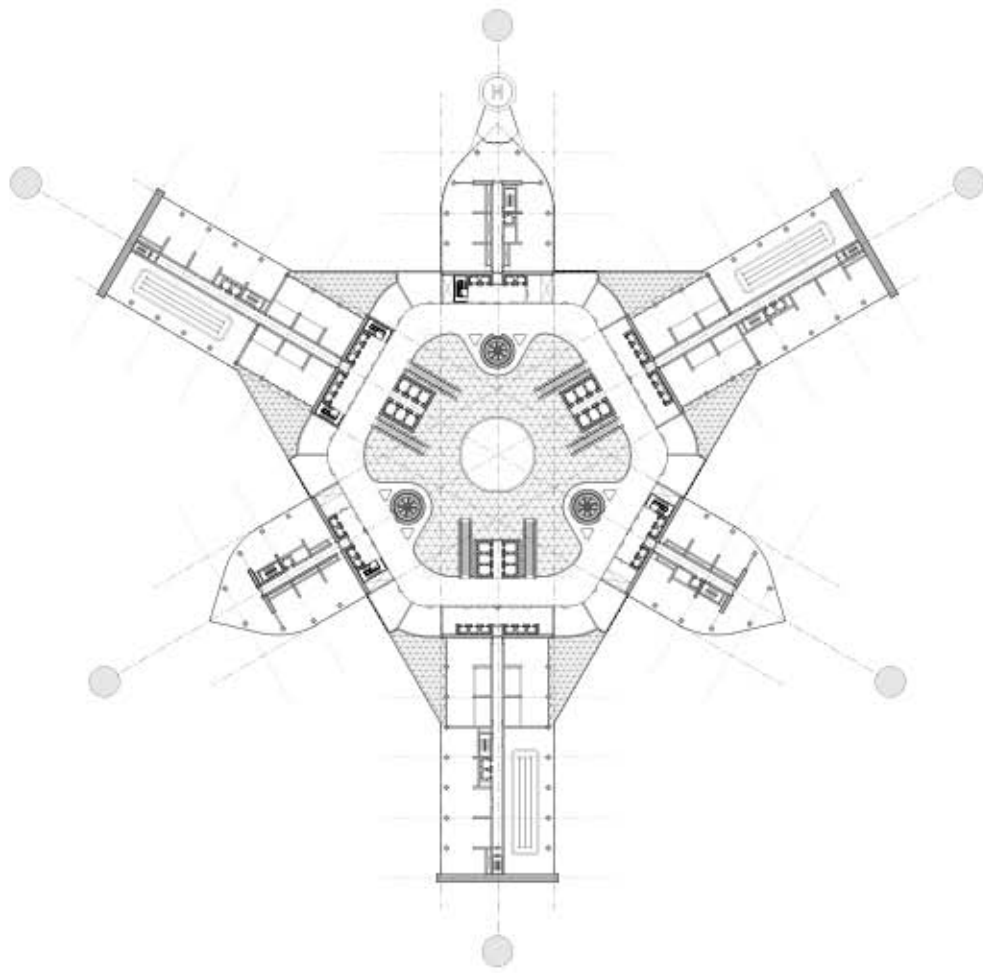

TYPICAL HIGH-RISE PLAZA LEVEL

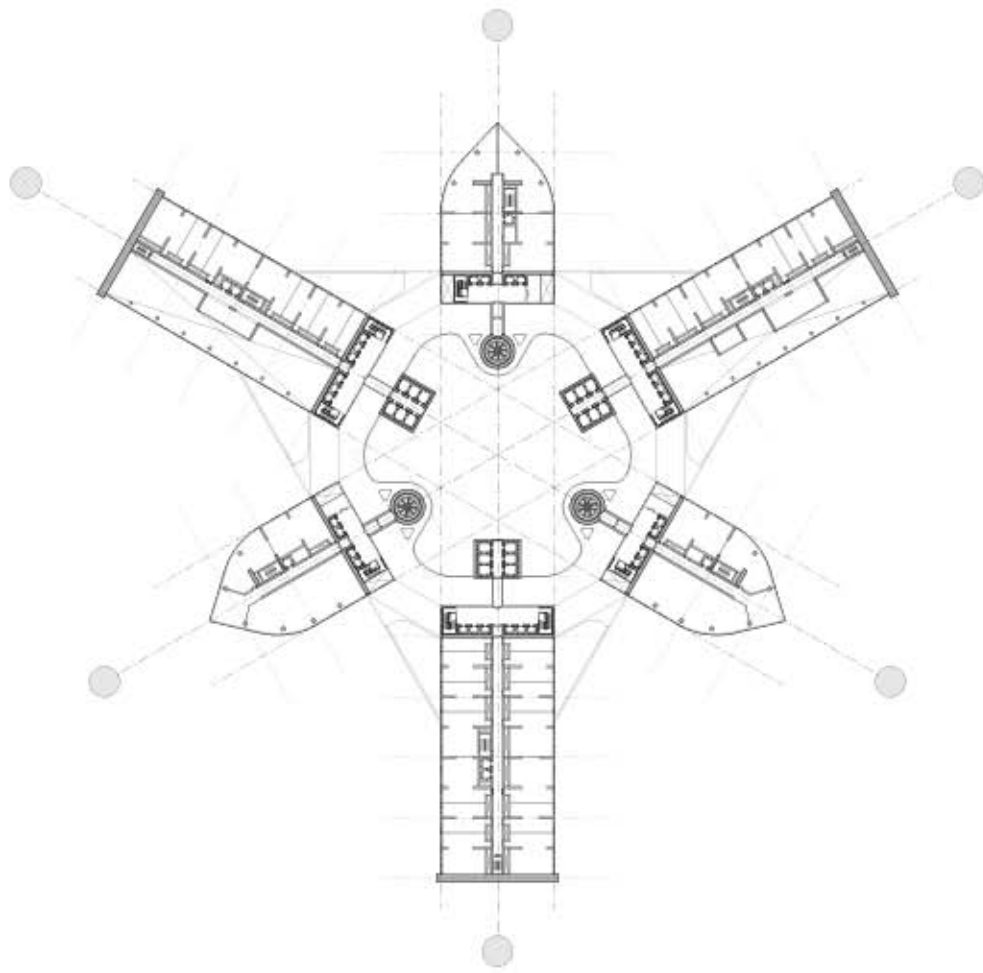

TYPICAL HIGH-RISE RESIDENTIAL LEVEL



Typical 200m Module

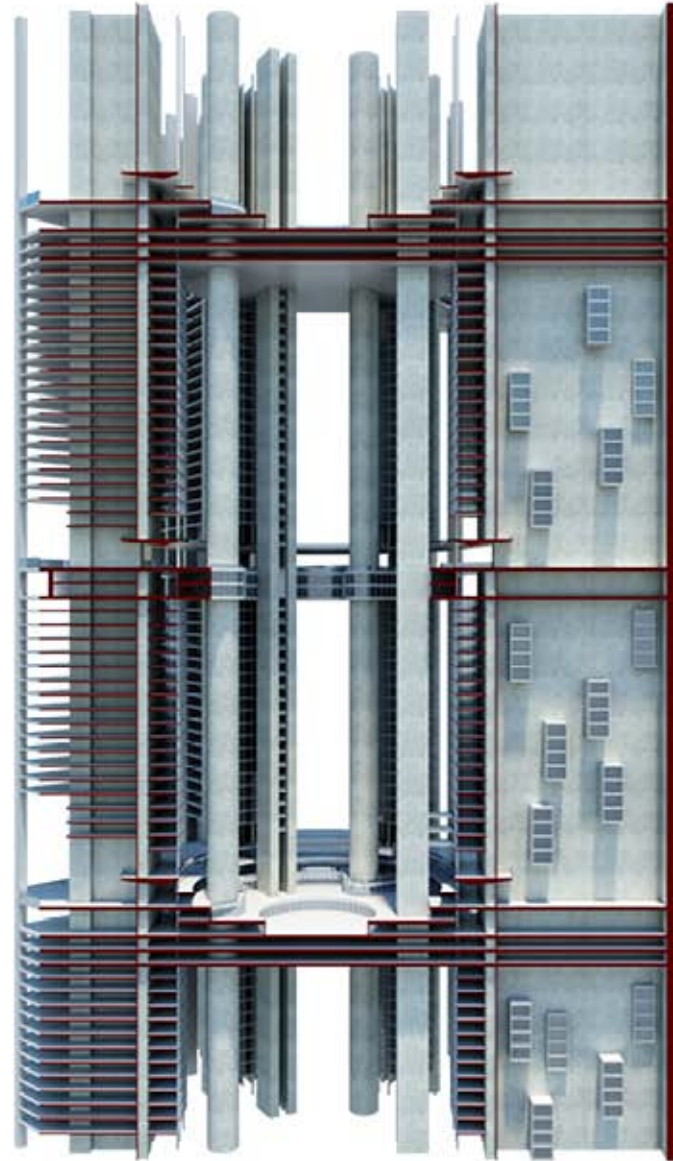

Typical 200m Module

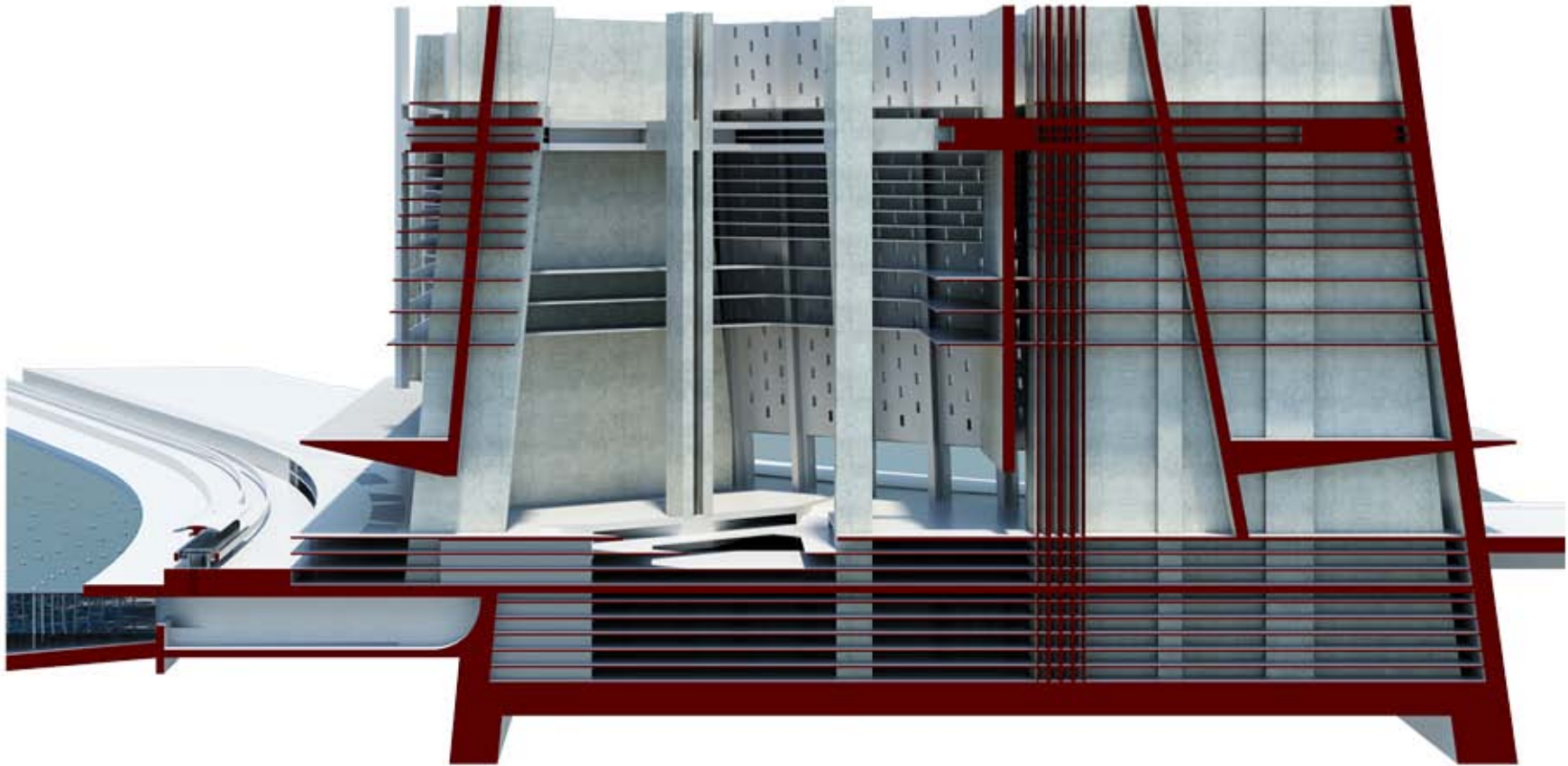

Cross Section at the Base

















INTENTIONALLY LEFT BLANK

5

APPENDIX

Fig. 76
Board 1:
Renderings 1



Fig. 77
Board 2:
Research
Diagrams

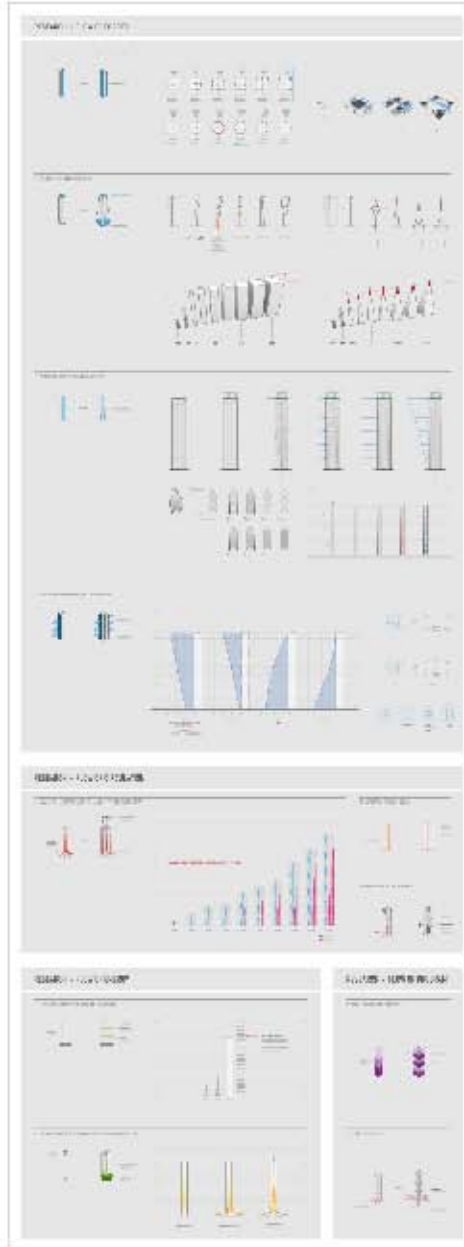

Fig. 78
Board 3:
Site & General
Info

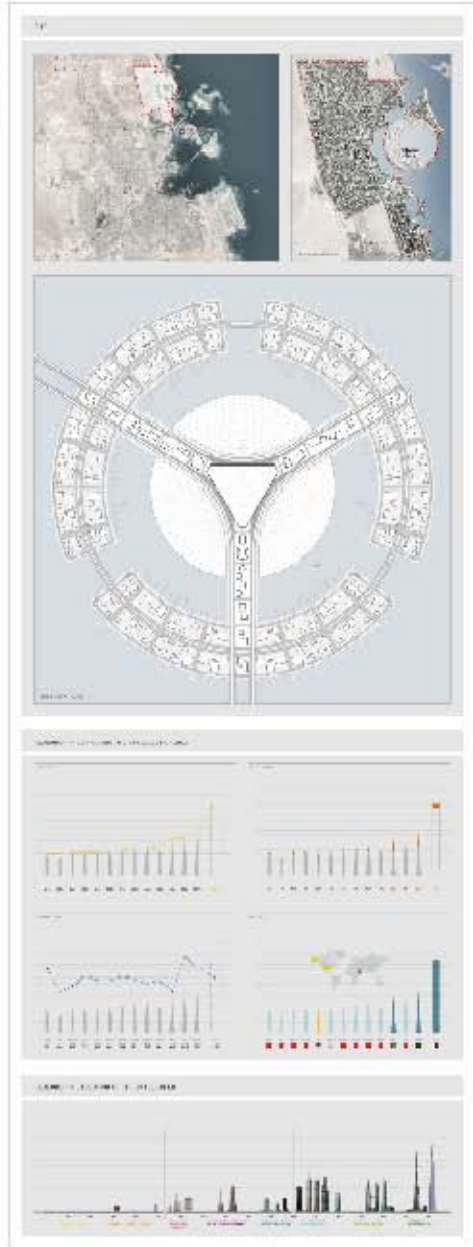

Fig. 79
Board 4:
Renderings 2



Fig. 80
Board 5:
Form Finding
Diagrams

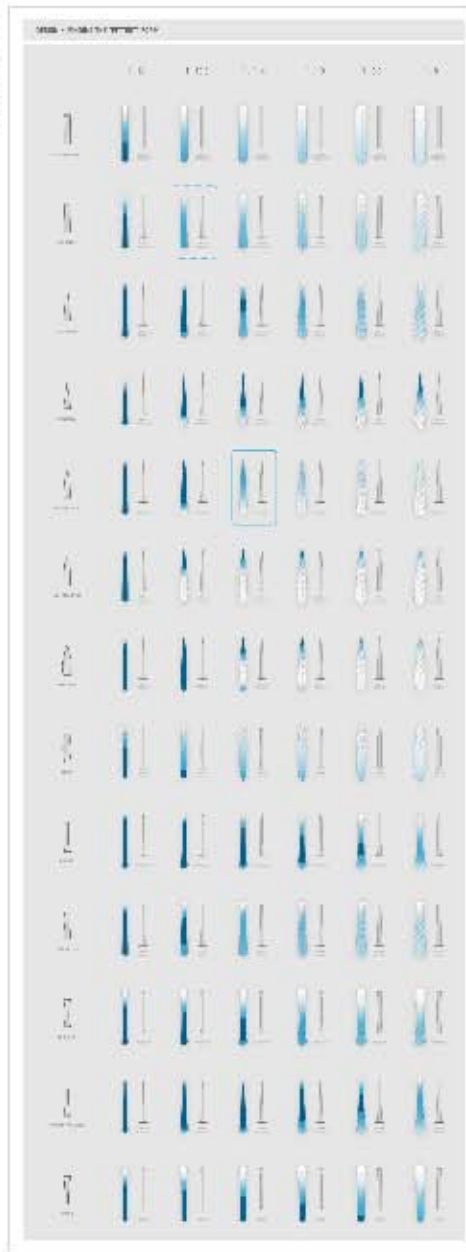

Fig. 81
Board 6:
Strategy
Diagrams

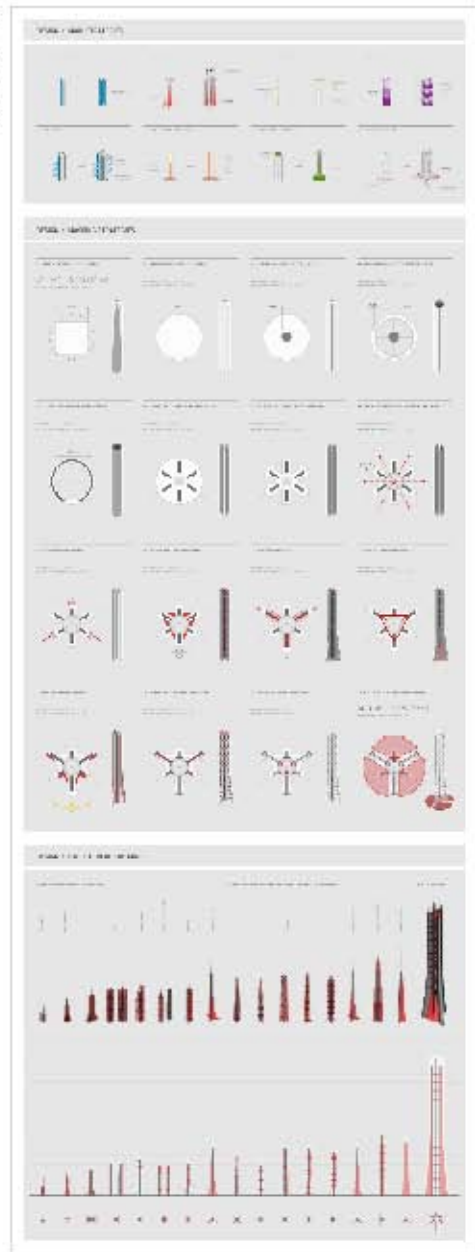

Fig. 82
Board 7:
Renderings 3



Fig. 83
Board 8:
System
Diagrams

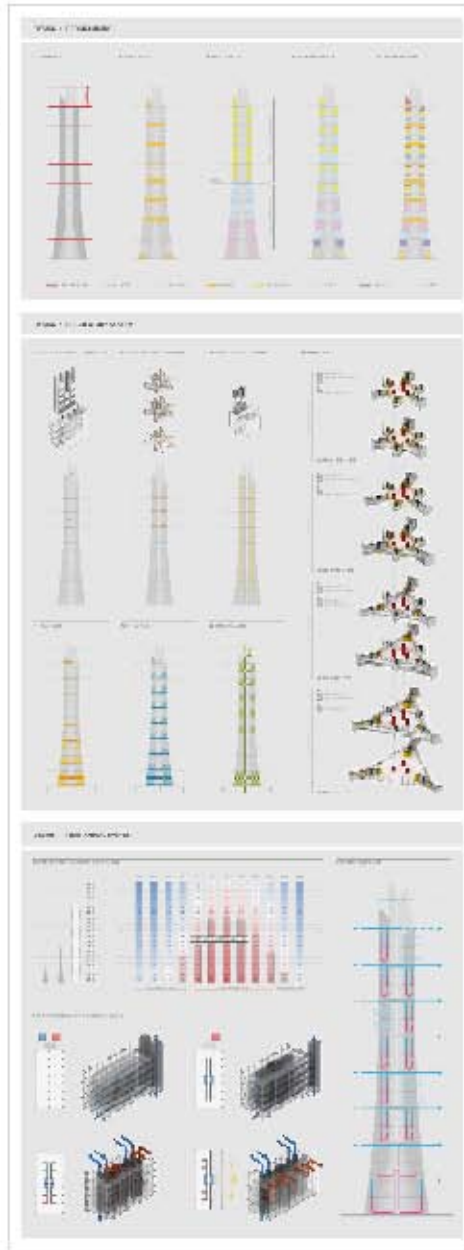

Fig. 84
Board 9:
Plans

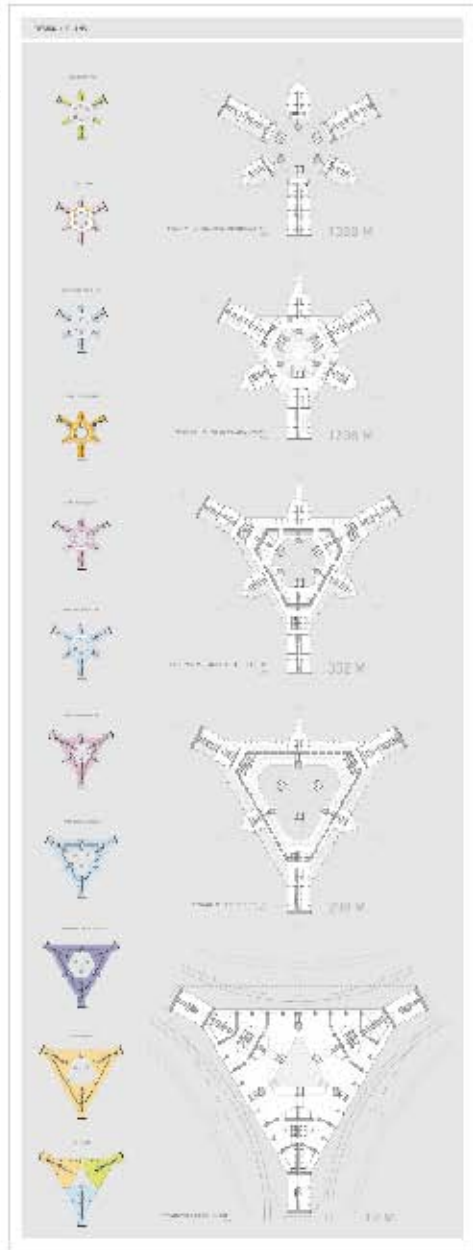

Fig. 85
Board 10:
Renderings 4



Fig. 86
Board 11:
Sections &
Program
Details

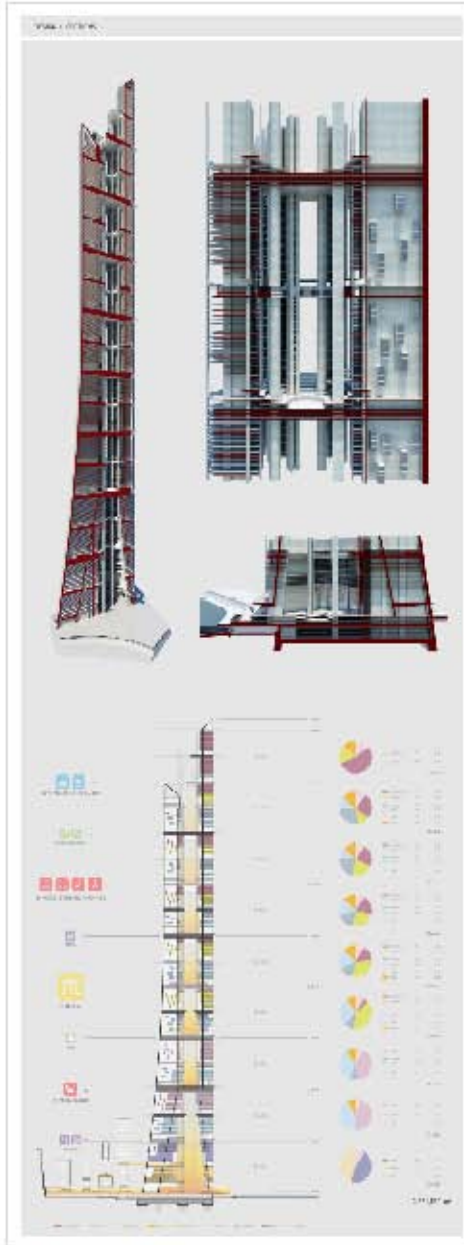

Fig. 87
Board 12:
Renderings 5



Bibliography

- Aerospaceweb.org. Atmospheric Properties Calculator . n.d. 2013 <<http://www.aerospaceweb.org/design/scripts/atmosphere/>>.
- Ali, M. and P. Armstrong. *Architecture of Tall Buildings*. New York: McGraw-Hill Book Company, 1995.
- Ascher, Kate. *The Hegiths: Anatomy of a Skyscraper*. The Penguin Press, 2011.
- Baker, William. *The World's Tallest Building - Burj Dubai*, U.A.E. Seoul, Korea, 2004.
- Bales, Richard. What do we know about the Great Chicago Fire? 12 May 2004. 13 April 2013 <<http://www.thechicagofire.com/>>.
- Bosschaert, Tom. Solar Updraft Tower Upgrade. 6 July 2009. October 2013 <<http://www.except.nl/en/#.en.articles.93-solar-updraft-tower-upgrade>>.
- Casparn, H. A. "The Riddle of the Tall Building: Has the Skyscraper a Place in American Architecture." *Stickley. The Craftsman*. 1906. 476-488.
- Cluckman, Ron. "How High Will They Build?" *Popular Science* (2003).
- CTBUH (Council on Tall Buildings & Urban Habitat). *Vanity Height: the Use-less Space in Today's Tallest*. September 2013. September 2013 <<http://www.ctbuh.org/Publications/Journal/InNumbers/TBINVanityHeight/tabid/5837/language/en-US/Default.aspx>>.
- CTBUH. *The Skyscraper Page: The Global Tall Building Databse of the CTBUH*. 2014. <<http://www.skyscrapercenter.com/>>.
- Davenport, A.G. "The Response of Six Building Shapes to Turbulent Wind *Philosophical Transactions of the Royal Society of London.*" *Mathematical and Physical Sciences* (1971): 385-394.
- Dubai Municipality. "Dubai Wind Code." 2013. 2013 <<https://www.dm.gov.ae/wps/wcm/connect/f7890833-ba29-4cf3-bd95-9a8eeca7e93/Dubai+Wind+Code22.pdf?MOD=AJPERES>>.
- Grimond, J. "The World Goes to Town." *The Economist* (2007).
- Halvorson and Partners. "Halvorson and Partners: Structural Engineers." n.d. *Wind Engineering Integration*. 2013 <<http://www.halvorsonandpartners.com/explore/31>>.
- Hayashida, H. : Iwasa, Y. "Aerodynamic Shape Effects of Tall Building for Vortex Induced Vibration." *Journal of Wind Engineering and Industrial Aerodynamics* (1990).
- Hibbeler, R. C. *Mechanics of Materials*, 7th Edition. 2007.
- Hollister, Nathaniel. *The Tallest 20 in 2020: Entering the Era of the Megatall*. Chicago: Council on Tall Buildings and Urban Habitat, 2011.
- Ilgin, H. Emre and M. Halis Günel. "The Role of Aerodynamic Modifications in the Form of Tall Buildings Against Wind Excitation." (2007).
- Irwin, P.A. "Developing Wind Engineering Techniques to Optimize Design and Reduce Risk." *UK Conference on Wind Engineering*. Wind Engineering Society, 2006.
- Kareem, A., T. Kijewski and Y. Tamura. "Mitigation of Motion of Tall Buildings with Recent Applications." *Wind and Structures* (1999): 201-251.
- Kawai, H. "Effect of Corner Modifications on Aeroelastic Instabilities of Tall Buildings." *Journal of Wind Engineering and Industrial Aerodynamics* (1998): 74-76.
- Koolhaas , Rem. *Content*. Taschen, 2004.
- Koolhaas, Rem. *Delirious New York: A Retroactive Manifesto for Manhattan*. The Monacelli Press, 1997.
- Lecher, Colin. "The World's Tallest Skyscrapers Have a Dirty Little Secret." *Popular Science* (2013).

Lusail Real Estate Development Company W.L.L. Lusail City. 2014. 2013 <http://www.lusail.com/English/Pages/English_Home.aspx>.

Masamichi, Nakagawa. "Aerodynamic Coefficients of a Dimpled Sphere in Back-Spin." *Nihon Kikai Gakkai Nenji Taikai Koen Ronbunshu* (2005): 89-90.

Risen, Clay. "The Rise of the Supertalls." *Popular Science* (2013).

Schueller, W. *High-Rise Building Structures*. New York: John and Wiley Sons Inc., 1977.

United Nations. United Nations, Department of Economic and Social Affairs. n.d. 2013 <<http://esa.un.org/unup/CD-ROM/Urban-Rural-Population.htm>>.

WeaterSpark. Average Weather for Dubai, United Arab Emirates. 2012. 2013 <<http://weatherspark.com/averages/32855/Dubai-United-Arab-Emirates>>.

Image Credits

- <Fig. 1> <http://encyclopedia.chicagohistory.org/pages/3524.html>
<Fig. 2> http://4.bp.blogspot.com/-EsJbwu0QVFY/UTbJMxNo1UI/AAAAAAAAAF6I/iTKcpBR6g_U/s1600/Sullivan-WainwrightBldg-B-1891.jpg
<Fig. 3> <http://architizer.com/blog/evolution-of-skyscraper/>
<Fig. 4> http://upload.wikimedia.org/wikipedia/commons/e/ec/Louis_Sullivan_-_Wainwright_Building,_Seventh_%2B_Chestnut_Streets,_Saint_Louis,_St._Louis_City_County,_MO.jpg
<Fig. 5> http://25.media.tumblr.com/tumblr_lzk52yfxSY1rodbnso1_1280.jpg
<Fig. 6> <http://toptravellists.net/wallpapers/2012/10/Black-and-white-New-York-United-States-1600x2560.jpg>
- <Fig. 7> <https://d2iweeeny6suwz.cloudfront.net/thumbnails-PRODUCTION/6f/35/6f359a6a520079ad2edf47de6b49317e.jpg>
<Fig. 8> <http://media-cache-ec0.pinimg.com/736x/23/a0/29/23a02987f1ea5dd1ecc6c514f0f0f251.jpg>
<Fig. 9> <http://arch-proect.com/wp-content/uploads/2013/01/Empair-21.jpg>
<Fig. 10> <http://c.ask.nate.com/imgs/knsi.tsp/137947/20187/30-6.jpg>
<Fig. 11> http://www.photographium.com/sites/default/files/rca_building_rockefeller_center_new_york_city_new_york_1933_september_1.jpg
<Fig. 12> <http://archleague.org/main/wp-content/uploads/2010/12/1929.jpg>
<Fig. 13> http://1.bp.blogspot.com/_mlPoGU4VqSk/S6OhTW8eShI/AAAAAAAAAHJI/iXBq9ITaJbk/s400/moses%5B1%5D.jpg
- <Fig. 14> <http://graphics8.nytimes.com/images/2013/04/07/arts/07SEAGRAM1/07SEAGRAM1-superJumbo.jpg>
<Fig. 15> <http://www.interiorclip.com/interior-image/lever-house-skidmore-owings-merrill-new-york-ny-bfccaeffeccda.jpg>
<Fig. 16> http://www.johnhancockcenterchicago.com/images/photo_hancock.jpg
<Fig. 17> <http://foundwalls.com/wallpapers/2012/10/World-Trade-Center-New-York-1800x2880.jpg>
<Fig. 18> http://www.blue-world.pl/menu_cudaswiata/naj_bud_swiata/willis_tower/6.jpg
<Fig. 19> <http://blog.baabespacios.com/wp-content/uploads/2012/03/obras666.jpg>
<Fig. 20> http://www.lehigh.edu/~infrk/images/Figure1{1}_1_800X600.jpg
<Fig. 21> http://www.worldofbuildings.com/aec_images/9-BruceGraham.jpg
- <Fig. 22> <http://i4.minus.com/iJo2y3piqlbdd.png>
<Fig. 23> http://www.anypics.ru/images/201211/anypics.ru_36311.jpg
<Fig. 24> <http://thefabweb.com/wp-content/uploads/2013/03/8t6OGQP.jpg>
<Fig. 25> <http://www.flickr.com>
<Fig. 26> <http://ugm.cl/ontherecord/wp-content/uploads/2011/10/Sao-Paulo.jpg>
<Fig. 27> http://luxfon.com/images/201203/luxfon.com_9966.jpg

<Fig. 28> <https://d2iweeeny6suwz.cloudfront.net/thumbnails-PRODUCTION/59/f8/59f8d7db1c72a497815446b17c40e3ae.jpg>

<Fig. 30> <http://www.dvice.com/sites/dvice/files/images/0object-15-skyscrapers-on-hold-Dubai-Towers.jpg>

<Fig. 31> <http://oi50.tinypic.com/idd5bc.jpg>

<Fig. 32> <http://wohndeem.minimalisti.com/wp-content/uploads/2012/07/Tanzende-Turme-Zaha-Hadid.jpg>

<Fig. 33> <http://assets.inhabitat.com/wp-content/blogs.dir/1/files/2011/12/The-Cloud-MVRDV-6.jpg>

<Fig. 34> http://gigart.ru/uploads/posts/2009-06/1245000654_1175584614_ren_7.jpg

<Fig. 35> http://assets.dezeen.com.s3.amazonaws.com/dezeen_One_Thousand_Museum_residential_skyscraper_Miami_large.jpg

<Fig. 36> <http://raazebaghaa.ir/imagecenter/images/eoob3lfg6reawd72pxm.jpg>

<Fig. 37> http://sphotos-a.ak.fbcdn.net/hphotos-ak-snc6/196528_415026685233492_927098748_n.png

<Fig. 38> <http://mirvishandgehrytoronto.com/wp-content/uploads/2013/06/north-view-towers.jpg>

<Fig. 39> http://img.archilovers.com/projects/b_730_00E7689C-90A8-49BE-A489-E12EA4E799AD.jpg

<Fig. 40> http://arquitecturadeco.files.wordpress.com/2013/01/list_3_4_20101125_074715_264.jpg

<Fig. 41> <http://3.bp.blogspot.com/-R5KoBwY7Jpo/T1nRJpoo0QI/AAAAAAAAABRE/RwPH2youD9g/s1600/10.jpg>

<Fig. 42> http://upload.wikimedia.org/wikipedia/commons/1/1a/Taipei_101_2009_amk-EditMylius.jpg

<Fig. 43> http://tamanduabandeirablog.files.wordpress.com/2013/03/burj_khalifa.jpg

<Fig. 44> <http://llnw.wbez.org/blog/insert-image/2011-August/2011-08-02/Jeddah%20Tower.jpeg>

<Fig. 61> <http://www.andrewschneider.com/gallery/series-IranYazd/630%5Bwind-towers.jpg>, <http://mw2.google.com/mw-panoramio/photos/medium/92902495.jpg>

<Fig. 70> <http://maps.google.com>

<Fig. 71> http://www.lusail.com/English/Pages/English_Home.aspx

INTENTIONALLY LEFT BLANK

INTENTIONALLY LEFT BLANK