

MIT Open Access Articles

Tensor network implementation of bulk entanglement spectrum

The MIT Faculty has made this article openly available. **Please share** how this access benefits you. Your story matters.

Citation: Hsieh, Timothy H., Liang Fu, and Xiao-Liang Qi. "Tensor Network Implementation of Bulk Entanglement Spectrum." Phys. Rev. B 90, no. 8 (August 2014). © 2014 American Physical Society

As Published: <http://dx.doi.org/10.1103/PhysRevB.90.085137>

Publisher: American Physical Society

Persistent URL: <http://hdl.handle.net/1721.1/89194>

Version: Final published version: final published article, as it appeared in a journal, conference proceedings, or other formally published context

Terms of Use: Article is made available in accordance with the publisher's policy and may be subject to US copyright law. Please refer to the publisher's site for terms of use.



Tensor network implementation of bulk entanglement spectrumTimothy H. Hsieh,¹ Liang Fu,¹ and Xiao-Liang Qi²¹*Department of Physics, Massachusetts Institute of Technology, Cambridge, Massachusetts 02139, USA*²*Department of Physics, Stanford University, Stanford, California 94305, USA*

(Received 3 July 2014; published 25 August 2014)

Many topologically nontrivial states of matter possess gapless degrees of freedom on the boundary, and when these boundary states delocalize into the bulk, a phase transition occurs, and the system becomes topologically trivial. We show that tensor networks provide a natural framework for analyzing such topological phase transitions in terms of the boundary degrees of freedom which mediate it. To do so, we make use of a correspondence between a topologically nontrivial ground state and its phase transition to a trivial phase established in T. Hsieh and L. Fu ([arXiv:1305.1949](https://arxiv.org/abs/1305.1949)). This involved computing the bulk entanglement spectrum (BES) of the ground state upon tracing out an extensive subsystem. This work implements BES via tensor network representations of ground states. In this framework, the universality class of the quantum critical entanglement Hamiltonian in d spatial dimensions is either derived analytically or mapped to a classical statistical model in $d + 1$ dimensions, which can be studied using Monte Carlo or tensor renormalization-group methods. As an example, we analytically derive the universality classes of topological phase transitions from the spin-1 chain Haldane phase and demonstrate that the Affleck-Kennedy-Lieb-Tasaki (AKLT) wave function (and its generalizations) remarkably contains critical six-vertex (and, in general, eight-vertex) models within it.

DOI: [10.1103/PhysRevB.90.085137](https://doi.org/10.1103/PhysRevB.90.085137)

PACS number(s): 03.67.Mn, 75.10.Pq, 03.65.Ud

I. INTRODUCTION

Despite lacking a local order parameter, topological states contain a wealth of subtly encoded information [1–8], including in some cases topological invariants such as the Chern number and in other cases ground-state degeneracy on higher-genus manifolds, for example. Given the stark contrast between topological states and classically ordered states, it is natural that purely quantum notions are often necessary for analyzing topological states. In particular, measures of entanglement, which has no classical analog, have proven to be extremely useful. For example, the entanglement entropy between a subsystem and its complement has been used [9–13] to detect topological order in a ground state. Moreover, the full spectrum of the reduced density matrix, called the entanglement spectrum [14–22], has allowed simulation of the edge excitations of a topological ground state. In other words, tracing out a subsystem from a ground state achieves an effect similar to introducing excitations localized at the boundary of the subsystem.

With this paradigm in mind, two of us have introduced a technique called the bulk entanglement spectrum (BES) to study the *bulk* of a system [23]. Specifically, it was found that a topological state contains information about its phase transition to a trivial phase. How is it possible that a single wave function can give birth to quantum criticality associated with a topological phase transition? By using a special partition of the topological state that is extensive in all directions and possesses symmetry between the remaining and traced out subsystems, the resulting bulk entanglement Hamiltonian [see Eq. (1)] was argued either to be critical or to possess ground-state degeneracy. In the former case, the critical bulk entanglement Hamiltonian sits right at a phase transition between the original topologically nontrivial phase and a trivial phase. The essence of this argument is the discrete nature of topological order and extreme limits of the partition. When nearly nothing is traced out, the remaining subsystem is in the same topological

phase as the original nontrivial wave function. When nearly everything is traced out, the remaining subsystem consists of decoupled small “islands” and thus is topologically trivial. Tuning the geometry of the partition thus induces a phase transition in the entanglement Hamiltonian. If there is a single phase transition, then it must occur at the intermediate, symmetric partition defined above. This protocol, which is derived from a single wave function, differs markedly from the usual realization of a quantum phase transition by tuning parameters in a Hamiltonian. As a proof of concept, BES has rigorously been shown to work for integer quantum Hall states. The BES produces the massless Dirac spectrum expected at the transition between states with Chern numbers 1 and 0.

In this paper, we study the quantum phase transition in BES for generic matrix product states (MPSs) [24,25], which are efficient representations of generic noncritical states in one dimension. We analytically implement the BES technique and obtain a more explicit understanding of the entanglement Hamiltonian and topological phase transition. The partition function of this bulk entanglement Hamiltonian serves as the centerpiece of this work, with three primary uses. First, it allows us to identify the critical theory of the entanglement Hamiltonian. Second, it maps the quantum critical d -dimensional system to a classical $(d + 1)$ -dimensional system, enabling Monte Carlo numerics or tensor renormalization-group methods [26] to tackle quantum critical problems. Finally, it provides a dynamic picture of a topological phase transition and highlights the importance of edge states in mediating such a phase transition. We will explicitly show that the virtual degree of freedom in the MPSs gains a life of its own in the partition function, and it is precisely the interactions of these virtual elements which constitute the topological phase transition. While we focus on one-dimensional systems in this work, many of our techniques generalize to tensor network wave functions in any dimension.

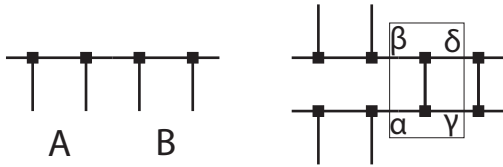

FIG. 1. (a) A segment of a matrix product state partitioned into two spatial subspaces, A and B . The open-ended vertical links represent physical degrees of freedom, and the horizontal links represent “virtual” degrees of freedom which are summed as in Eq. (2). (b) The reduced density matrix obtained by tracing out B . The MPS transfer matrix is shown by the box.

II. BULK ENTANGLEMENT SPECTRUM AND TENSOR NETWORKS

We begin by briefly reviewing BES and tensor networks before using them together. Consider a ground state $|\Psi\rangle$ defined on a Hilbert space S and partition S into two complementary parts, A and B . After tracing out part B , the description of $|\Psi\rangle$ on A is given by a thermal density matrix

$$\rho_A = \text{Tr}_B |\Psi\rangle\langle\Psi| \equiv e^{-H_A}, \quad (1)$$

corresponding to an entanglement Hamiltonian H_A . The entanglement spectrum is the set of eigenvalues of H_A , and in the following we will be interested in the ground state of H_A and its topological nature.

When an *extensive partition* is used, i.e., when A and B are extensive with system size in all directions, one attains a *bulk* entanglement Hamiltonian: H_A has support on an extensive subsystem A . It was argued in [23] that when the ground state $|\Psi\rangle$ is an irreducible topological state [27] and when A and B are related by symmetry, H_A either (1) has ground-state degeneracy or (2) is gapless and characterizes a topological phase transition from nontrivial to trivial. As outlined earlier, this claim can be motivated by considering extreme examples of extensive partitions. The critical point occurs at the symmetric partition in which A and B are related by a symmetry such as translation.

Tracing out degrees of freedom has a convenient pictorial representation in the framework of tensor networks. Consider a MPS given by a tensor M_{α}^{σ} with a physical index σ and virtual indices $\{\alpha\}$ emanating from the physical sites [see Fig. 1(a)]. The virtual indices are contracted, leaving a wave function $|\psi\rangle$ defined by

$$\langle\sigma_1 \cdots \sigma_N|\psi\rangle \equiv \sum_{\text{virtual indices}} M^{\sigma_1} \cdots M^{\sigma_N}. \quad (2)$$

The reduced density matrix ρ_A obtained from tracing out part B is

$$\rho_A = \sum_{\sigma_B} \langle\sigma_B|\psi\rangle\langle\psi|\sigma_B\rangle. \quad (3)$$

Graphically, $\langle\psi|$ is simply represented by reflecting the MPS $|\psi\rangle$ and complex conjugating the tensors. Then, the σ_B indices are contracted to yield ρ_A [Fig. 1(b)]. In this pictorial language, the topological phase transition realized by tuning the extensive partition is shown in Fig. 2, in which the density matrix interpolates between the nontrivial projector onto the topological ground state and a trivial product of density

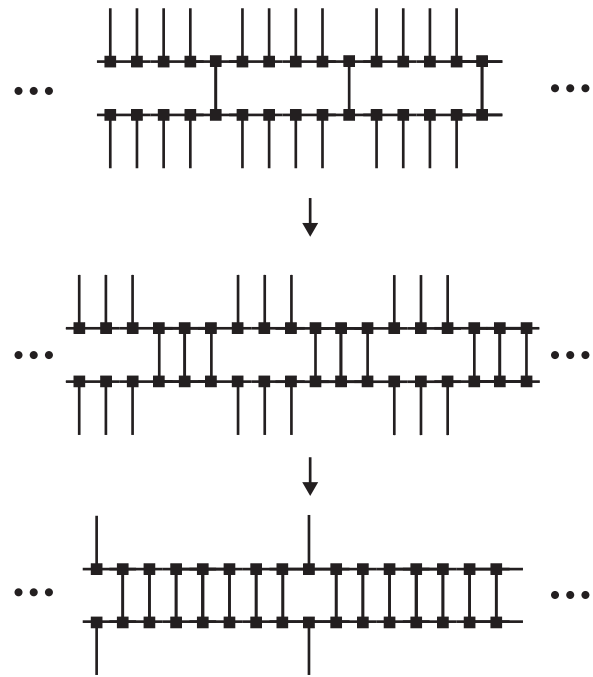

FIG. 2. The tensor network representation of the BES procedure. The reduced density matrices ρ_A corresponding to different extensive partitions are shown. Tuning the extensive partition of a topologically nontrivial ground state Ψ realizes a topological phase transition that occurs at the partition where A and B are symmetric (middle). If too little is traced out (top), $\rho_A \approx |\Psi\rangle\langle\Psi|$ is nontrivial. If too much is traced out (bottom), $\rho_A \approx \otimes_{i \in A} \rho_i$ is trivial.

operators. The phase transition occurs at a partition in which A and B are related by some symmetry.

III. PARTITION FUNCTION OF ENTANGLEMENT HAMILTONIAN

It is now extremely useful to construct the partition function of the entanglement Hamiltonian $Z = \text{tr}(e^{-nH_A}) = \text{tr}(\rho_A^n)$, where $n = 1/T$ is the inverse “temperature.” We will eventually take the limit $T \rightarrow 0$ ($n \rightarrow \infty$) to probe the universality class of H_A . Graphically, one simply stacks n copies of ρ_A and then contracts all physical indices, including those at the top of the n th copy and those at the bottom of the first copy. Because all indices are contracted, we now have the freedom to reinterpret the partition function as one involving the virtual degrees of freedom, thus providing a different perspective on the topological phase transition being studied. In some cases, we can rewrite the partition function as $Z = \text{tr}(e^{-\beta\tilde{H}})$, where \tilde{H} now acts on the virtual indices as opposed to the physical indices. Hence, we call \tilde{H} the effective entanglement Hamiltonian. Equally important, the partition function can be understood as that of a classical model (in one higher dimension) if the Boltzmann weights of all configurations are nonnegative. The above holds for general extensive partitions, yet it is particularly interesting at the symmetric partition, where the partition function of the critical quantum model can be studied using Monte Carlo or

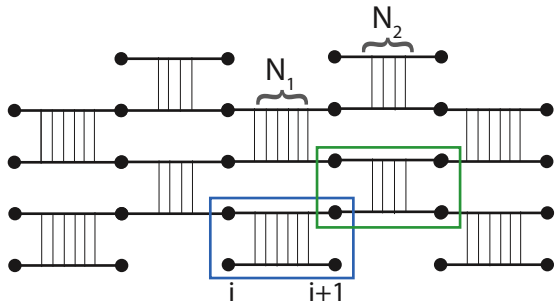

FIG. 3. (Color online) The partition function corresponding to the entanglement Hamiltonian from an extensive partition, tracing out blocks of N_1 sites and leaving N_2 sites in between. Boxed in blue and green are the building blocks of the partition function, namely, the transfer matrices propagating two virtual degrees of freedom from one layer to the next.

tensor renormalization-group methods to attain approximate critical exponents.

Choosing the two subsystems A and B of the extensive partition to be alternating blocks of N_1 and N_2 spins, respectively, we follow the general procedure outlined above and obtain the tensor network state (TNS) structure of the partition function, shown in Fig. 3. Interestingly, this TNS can be viewed as a partition function for the virtual degrees of freedom (depicted by and hereafter referred to as dots) located at the ends of each block. Each “ladder diagram” obtained by contracting physical indices (blue or green boxes in Fig. 3) plays the role of a time evolution operator acting on two virtual sites. The value of the ladder can be evaluated by defining the transfer matrix T acting on the auxiliary indices, defined as $T_{\alpha\beta;\gamma\delta} = \sum_{\sigma} M_{\alpha\gamma}^{\sigma} (M^{\sigma*})_{\beta\delta}$ (see Fig. 1). The two basic building blocks boxed in Fig. 3 are then given by T^{N_1}, T^{N_2*} . When we permute the vertices and view $[T^{N_1}]_{\alpha\beta;\gamma\delta}$ as a mapping from auxiliary indices $\alpha\gamma$ to $\beta\delta$, it describes the “imaginary time evolution” of the virtual sites $i, i+1$ for odd i and on odd-numbered rows. Similarly, T^{N_2} acts on sites $j, j+1$ for even j and even-numbered rows.

Further simplification can be made by considering large N_1, N_2 ; in this limit, the transfer matrix $T^{N_{i(2)}}$ will be dominated by leading eigenvalues of T . As is well known for MPSs, by transformations in the virtual indices one can always transform T into a canonical form. As we show in the Supplemental Material [28], for the canonical T in the limit of large N_1, N_2 , neighboring dots become almost decoupled, and T^N has the form of

$$T^N \approx \lambda(1 \otimes 1) + \xi_2^N (U_2^L \otimes U_2^R), \quad (4)$$

where $\lambda > 0$ is a constant, 1 is the identity operator acting on a single dot, ξ_2 is the second largest eigenvalue of the double tensor of the MPS, and $U_2^{L,R}$ are the corresponding left and right eigenvectors, respectively (they are, nonetheless, operators acting on a single dot). The tensor product above is that between two adjacent dots. The key point is that MPSs which represent gapped ground states have a nondegenerate largest eigenvalue of the double tensor. This allows us to analyze the large N , “weak-coupling” limit.

Up to a constant λ , each transfer matrix is nearly the identity. Therefore we can write $T^N \simeq \lambda \exp[\xi_2^N \lambda^{-1} U_2^L \otimes U_2^R]$. The Suzuki-Trotter expansion ($e^A e^B \approx e^{A+B}$ for small A, B) allows us to ignore the commutator arising from the overlap of T^{N_1} and T^{N_2} (i.e., the green and blue boxes in Fig. 3) and write

$$Z \approx \text{tr}(e^{-n\tilde{H}}), \quad (5)$$

$$\tilde{H} \equiv - \sum_{\text{odd } i} \xi_2^{N_1} \lambda^{-1} (U_2^L)_i \otimes (U_2^R)_{i+1} - \sum_{\text{even } j} \xi_2^{N_2} \lambda^{-1} (U_2^L)_j \otimes (U_2^R)_{j+1}, \quad (6)$$

up to a constant.

IV. APPLICATION TO HALDANE PHASE

We now demonstrate this procedure explicitly for the BES of the Haldane phase of the spin-1 chain [29]. This is a topologically nontrivial phase protected by either time reversal, a dihedral subgroup of rotations (detailed later), or inversion symmetry [19,30]. We begin by analyzing a representative of the Haldane phase: the Affleck-Kennedy-Lieb-Tasaki (AKLT) matrix product state [31],

$$M^+ = \sqrt{\frac{2}{3}} \sigma^+, \quad M^0 = -\frac{1}{\sqrt{3}} \sigma^z, \quad M^- = -\sqrt{\frac{2}{3}} \sigma^-. \quad (7)$$

Here, $\pm, 0$ stand for $S^z = \pm 1, 0$, and σ are the Pauli spin matrices, with $\sigma^{\pm} = \frac{1}{2}(\sigma^x \pm i\sigma^y)$. The transfer matrix is $T_{\alpha\beta;\gamma\delta} = \frac{1}{3} \sum_{i=x,y,z} \sigma_{\alpha\gamma}^i \sigma_{\beta\delta}^{i*} = \frac{2}{3}(\delta_{\alpha\beta}\delta_{\gamma\delta} - \frac{1}{2}\delta_{\alpha\gamma}\delta_{\beta\delta})$. Viewing T as a two-site operator acting on the auxiliary indices, we can write

$$T = \frac{1}{2}(1 \otimes 1 - \frac{1}{3}\vec{\sigma} \cdot \vec{\sigma}^*). \quad (8)$$

This transfer matrix corresponds to $\xi_2 = -\frac{1}{3}$, $U_2^L = \sigma^i$, $U_2^R = \sigma^{i*}$ in the generic formula, with a threefold degeneracy in the eigenstates. After a unitary transformation on the odd sites $\vec{\sigma}^* = -\sigma_y \vec{\sigma}_y$, the effective entanglement Hamiltonian has the Heisenberg form:

$$\tilde{H} \equiv - \left(-\frac{1}{3}\right)^{N_1} \sum_{\text{odd } i} P_{i,i+1} - \left(-\frac{1}{3}\right)^{N_2} \sum_{\text{even } j} P_{j,j+1},$$

up to a constant. Here P is the projection operator of two spin-1/2s onto the singlet state.

Hence we find that for large even N_1, N_2 , the entanglement Hamiltonian has the same spectrum as the antiferromagnetic spin-1/2 Heisenberg chain with alternating nearest-neighbor couplings. A quantum phase transition occurs at the symmetric partition $N_1 = N_2$, where the BES describes a spin-1/2 translation-invariant Heisenberg chain. The quantum phase transition can also be understood in terms of the original spin-1 model. In the limit $N_1 \ll N_2$, region A consists of isolated blocks, while in the opposite limit, $N_1 \gg N_2$, it is in the Haldane phase. Therefore the phase transition is one between the Haldane phase and a trivial product state, driven by translation symmetry breaking. Indeed, this transition is known to be described by $SU(2)$ level-1 Wess-Zumino-Witten

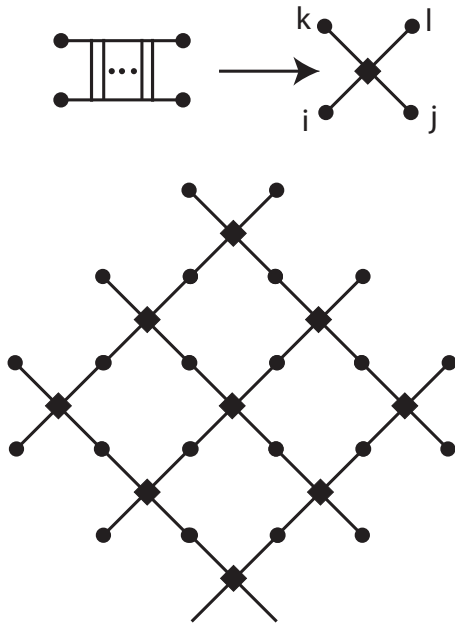

FIG. 4. The partition function from the entanglement Hamiltonian at the symmetric partition is identified as a classical partition function. (top) The transfer matrix is interpreted as a vertex interaction between Ising variables (large dots). (bottom) The resulting classical model is defined on a new lattice.

(WZW) theory [32–34], the same conformal field theory that describes the Heisenberg spin-1/2 chain.

Although the above derivation applies generally to any extensive partition of any MPS representation of a gapped ground state, it is valid only in the large N_1, N_2 limit, an approximation which may not hold in general in higher dimensions. Hence we now provide a complementary analysis that (1) holds for arbitrary N_1, N_2 and (2) generalizes readily to higher dimensions: we view the partition function as that of a (two-dimensional) classical model. Because we are interested in the topological phase transition expected from BES, we focus on the symmetric partition $N_1 = N_2 = N$ for the AKLT state. Upon redrawing the tensor network so that each set of N contracted physical indices serves as an interaction vertex between four spin-1/2 nodes (Fig. 4), we find that the classical partition function is that of a particular six-vertex model on a square lattice with vertex weights

$$V_{kl}^{ij} = \delta_k^i \delta_l^j + \lambda \delta_j^i \delta_l^k, \quad \lambda = \frac{(-3)^N - 1}{2}.$$

In this model, there are two possible states on each link of the square lattice, and the weight of each configuration in the partition function is given by the product of the above vertex terms. It is remarkable that the AKLT wave function “contains” such six-vertex models, which are exposed by BES. For the above parameters, the model is critical, equivalent to the four-state Potts model, and is described in the continuum limit by the level-1 $SU(2)$ WZW theory [35].

V. GENERALIZATIONS

This particular universality class is a consequence of the $SO(3)$ symmetry of the AKLT MPS. However, recall that

the full $SO(3)$ symmetry group is not necessary to protect the topological Haldane phase. Hence we now consider MPS ground states which are slightly perturbed away from the AKLT state, and we analyze the nature of the bulk entanglement Hamiltonian in such cases. For this purpose, it is useful to make the spin symmetries manifest by parameterizing these MPSs as [36]

$$M^x = a\sigma^x, \quad M^y = b\sigma^y, \quad M^z = c\sigma^z, \quad (9)$$

where a, b, c are real numbers. Comparing (9) to (7), we are simply using a new basis: $|\pm\rangle = \frac{1}{\sqrt{2}}(x \pm iy)$, $|0\rangle = z$. When $a = b = c$, the MPS is the $SO(3)$ symmetric AKLT state up to an overall normalization, and when two of the coefficients are equal, the MPS has at least a $U(1)$ symmetry (in the plane corresponding to those two coefficients). Finally, when all three parameters are different, the MPS still has dihedral symmetry generated by rotations by π about the x, y, z axes.

Parameterizing small perturbations to the AKLT state by $a = 1, b = 1 + \delta, c = 1 + \epsilon$, we proceed as above and find that the entanglement Hamiltonian from the symmetric partition in the large N and small δ, ϵ limit is given by the XYZ spin-1/2 chain (see the Supplemental Material [28]). More specifically, the spin symmetry of the MPS ground state is in one-to-one correspondence with the symmetry of the entanglement Hamiltonian: the AKLT MPS yields the Heisenberg chain, the MPS with $U(1)$ symmetry yields the XXZ chain, and the most general MPS of the form (9) yields the XYZ chain. Since the XYZ chain either is critical or spontaneously orders along a direction [37–39], the corresponding entanglement Hamiltonian either is critical or has ground-state degeneracy, both of which are consistent with our general arguments [23].

Because of the two free parameters in the MPS, the resulting entanglement Hamiltonian will generically be in the gapped part (with ground-state degeneracy) of the XYZ phase diagram. If the MPS is fine-tuned so that the corresponding entanglement Hamiltonian lies on one of the critical lines, then the universality class can be simply extracted from the XYZ model. All critical lines in the XYZ phase diagram map to the XXZ chain [39], which in turn can be mapped via bosonization to (critical) Luttinger liquids with the Luttinger parameter depending on the XXZ anisotropy. We conclude that such critical theories describe the transition of the Haldane phase to a topologically trivial dimerized phase.

Alternatively, for finite N , we can also map the partition function of the entanglement Hamiltonian for this wider class of MPSs to classical models in two dimensions, as we derived a six-vertex model from the AKLT state. We find that the general class of MPSs of the form (9) maps into eight-vertex models [37], although in some cases the weights of some configurations may be negative.

VI. SUMMARY AND OUTLOOK

By using tensor networks to construct the partition function of the critical bulk entanglement Hamiltonian, we gain much insight into the topological phase transition revealed by BES. Previously, topological phase transitions have been described by the condensation of fractionalized excitations or the delocalization of edge states [40]; in both cases, the original degrees

of freedom of the model are overshadowed by emergent ones. Thanks to the partition function and the tensor network framework, we have a clear picture of the virtual degrees of freedom interacting and giving rise to the phase transition. As a by-product of this procedure, we attain classical lattice models of quantum critical points; as an example, we derived critical six-vertex models from the AKLT wave function. We note that this tensor network implementation of BES generalizes readily to higher dimensions, in which interesting quantum-classical mappings may await.

Note added. Recently, we noticed numerical results [41] for a fixed extensive partition of the AKLT chain in which alternating blocks of two sites are traced out. We also noticed a recently posted study relating entanglement properties from

extensive partitions of spin chains to classical models [42]. These results support our conclusions.

ACKNOWLEDGMENTS

We thank T. Senthil for informing us of the relation between the Heisenberg model and the four-state Potts model. T.H. is supported by NSF Graduate Research Fellowship No. 0645960. L.F. is supported by the DOE Office of Basic Energy Sciences, Division of Materials Sciences and Engineering, under Award No. DE-SC0010526. X.-L.Q. is supported by the National Science Foundation through the Grant No. DMR-1151786.

-
- [1] D. J. Thouless, M. Kohmoto, M. P. Nightingale, and M. den Nijs, *Phys. Rev. Lett.* **49**, 405 (1982).
 - [2] M. Z. Hasan and C. L. Kane, *Rev. Mod. Phys.* **82**, 3045 (2010).
 - [3] X. L. Qi and S. C. Zhang, *Rev. Mod. Phys.* **83**, 1057 (2011).
 - [4] J. E. Moore, *Nature (London)* **464**, 194 (2010).
 - [5] X. G. Wen and Q. Niu, *Phys. Rev. B* **41**, 9377 (1990).
 - [6] X. G. Wen, *Int. J. Mod. Phys. B* **4**, 239 (1990).
 - [7] C. L. Kane and E. J. Mele, *Phys. Rev. Lett.* **95**, 146802 (2005).
 - [8] C. Nayak, S. H. Simon, A. Stern, M. Freedman, and S. Das Sarma, *Rev. Mod. Phys.* **80**, 1083 (2008).
 - [9] M. Levin and X. G. Wen, *Phys. Rev. Lett.* **96**, 110405 (2006).
 - [10] A. Kitaev and J. Preskill, *Phys. Rev. Lett.* **96**, 110404 (2006).
 - [11] A. Hamma, R. Ionicioiu, and P. Zanardi, *Phys. Lett. A* **337**, 22 (2005).
 - [12] A. Hamma, R. Ionicioiu, and P. Zanardi, *Phys. Rev. A* **71**, 022315 (2005).
 - [13] Y. Zhang, T. Grover, A. Turner, M. Oshikawa, and A. Vishwanath, *Phys. Rev. B* **85**, 235151 (2012).
 - [14] H. Li and F. D. M. Haldane, *Phys. Rev. Lett.* **101**, 010504 (2008).
 - [15] V. Alba, M. Haque, and A. M. Lauchli, *Phys. Rev. Lett.* **108**, 227201 (2012).
 - [16] A. Chandran, M. Hermanns, N. Regnault, and B. A. Bernevig, *Phys. Rev. B* **84**, 205136 (2011).
 - [17] X.-L. Qi, H. Katsura and A. W. W. Ludwig, *Phys. Rev. Lett.* **108**, 196402 (2012).
 - [18] B. Swingle and T. Senthil, *Phys. Rev. B* **86**, 045117 (2012).
 - [19] F. Pollmann, A. M. Turner, E. Berg, and M. Oshikawa, *Phys. Rev. B* **81**, 064439 (2010).
 - [20] L. Fidkowski, *Phys. Rev. Lett.* **104**, 130502 (2010).
 - [21] H. Yao and X.-L. Qi, *Phys. Rev. Lett.* **105**, 080501 (2010).
 - [22] J. Dubail and N. Read, *Phys. Rev. Lett.* **107**, 157001 (2011).
 - [23] T. Hsieh and L. Fu, [arXiv:1305.1949](https://arxiv.org/abs/1305.1949).
 - [24] M. Fannes, B. Nachtergaele, and R. F. Werner, *Commun. Math. Phys.* **144**, 443 (1992).
 - [25] F. Verstraete and J. I. Cirac, [arXiv:cond-mat/0407066](https://arxiv.org/abs/cond-mat/0407066).
 - [26] M. Levin and C. P. Nave, *Phys. Rev. Lett.* **99**, 120601 (2007).
 - [27] A topological state is dubbed irreducible if it cannot be written as the direct product of two states with identical, nontrivial topological invariants or order. An example (counterexample) is a state with Chern number $\nu = 1$ (2).
 - [28] See Supplemental Material at <http://link.aps.org/supplemental/10.1103/PhysRevB.90.085137> for a derivation of the effective entanglement Hamiltonian, and application to AKLT and perturbed AKLT chain.
 - [29] F. D. M. Haldane, *Phys. Lett. A* **93**, 464 (1983).
 - [30] Z.-C. Gu and X.-G. Wen, *Phys. Rev. B* **80**, 155131 (2009).
 - [31] I. Affleck, T. Kennedy, E. H. Lieb, and H. Tasaki, *Phys. Rev. Lett.* **59**, 799 (1987).
 - [32] I. Affleck and F. D. M. Haldane, *Phys. Rev. B* **36**, 5291 (1987).
 - [33] J. Wess and B. Zumino, *Phys. Lett. B* **37**, 95 (1971).
 - [34] E. Witten, *Commun. Math. Phys.* **92**, 455 (1984).
 - [35] I. Affleck, *Phys. Rev. Lett.* **55**, 1355 (1985).
 - [36] Z.-X. Liu, M. Liu, and X.-G. Wen, *Phys. Rev. B* **84**, 075135 (2011).
 - [37] R. J. Baxter, *Ann. Phys. (NY)* **70**, 323 (1972).
 - [38] J. D. Johnson, S. Krinsky, and B. M. McCoy, *Phys. Rev. A* **8**, 2526 (1973).
 - [39] M. P. M. den Nijs, *Phys. Rev. B* **23**, 6111 (1981).
 - [40] For a general discussion of how delocalized edge states contribute to the critical theory of a phase transition, see X. Chen, F. Wang, Y.-M. Lu, and D.-H. Lee, *Nucl. Phys. B* **873**, 248 (2013).
 - [41] W.-J. Rao, X. Wan, and G.-M. Zhang, [arXiv:1406.7113](https://arxiv.org/abs/1406.7113).
 - [42] R. A. Santos, [arXiv:1408.1716](https://arxiv.org/abs/1408.1716) (2014).