

Product Family Formation in Linked-Cell Manufacturing System Design

By

David C. Estrada

B.S. Mechanical Engineering
Massachusetts Institute of Technology, 1998

SUBMITTED TO THE DEPARTMENT OF MECHANICAL ENGINEERING IN PARTIAL
FULFILLMENT OF THE REQUIREMENTS FOR THE DEGREE OF

MASTER OF SCIENCE IN MECHANICAL ENGINEERING
AT THE
MASSACHUSETTS INSTITUTE OF TECHNOLOGY

JUNE 2000

© 2000 Massachusetts Institute of Technology
All Rights Reserved

Signature of Author: _____
Department of Mechanical Engineering
May 5, 2000

Certified by: _____
David S. Cochran
Assistant Professor of Mechanical Engineering
Thesis Supervisor

Approved by: _____
Ain A. Sonin
Professor of Mechanical Engineering
Chairman, Graduate Committee

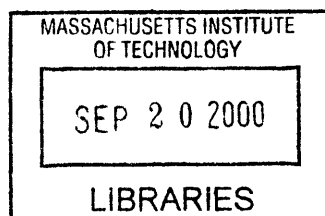

Product Family Formation in Linked-Cell Manufacturing System Design

By

David C. Estrada

Submitted to the Department of Mechanical Engineering
on May 5, 2000 in Partial Fulfillment of the
Requirements for the Degree of Master of Science in
Mechanical Engineering

ABSTRACT

The work presented herein focuses on the design of a linked-cell manufacturing system for a company moving into a new facility. In the current plant, a traditional mass production system is in place, with parts advancing through a series of functional departments on the fabrication side of production, and then being assembled on moving assembly lines. The first step taken in the design of the new system was to demonstrate cell feasibility, with respect to the specific product, by replacing one of the moving belt assembly lines with two cells. The cells outperformed the assembly line, and thus allowed for the next steps of the design process to be pursued which included 1) an assessment of each current piece of equipment to determine if it was cell compatible “as-is,” needed modification, or required complete replacement, and 2) proposing a complete plan for conversion. In order to accomplish these tasks it was necessary to form product families. The basis used for forming product families dictates the complexity of the manufacturing system design at all levels – system, subsystem (cell), and machine – and thus ultimately determines whether conversion to the new system is cost justifiable.

The design effort resulted in a plan to break conversion of the overall system into two stages. The first stage, referred to as the interim plan, calls for the complete conversion of the final assembly lines to cells. The second stage involves the implementation of fabrication cells that will be linked to the assembly cells formed in the interim. In order for the fabrication cells to be formed several equipment design issues need to be addressed. Other recommended changes regard the product design and allocation of support personnel.

Thesis Supervisor: David S. Cochran
Title: Assistant Professor of Mechanical Engineering

Acknowledgements

Over the past six years, I have greatly matured as a student of engineering, and for that I am indebted to Professor David S. Cochran who served as my advisor during undergraduate and graduate studies. For support of my graduate research, and for helping me grow in an industry setting, I would like to thank Mark Winters and Victor Carrillo of Coclisa, along with Bart Hogarth of Visteon's Climate Control Headquarters. The experience of researching on-site was a "bumpy ride," but I feel that all involved have greatly benefited from traveling down the road of change together. I am also thankful for having the opportunity to work with Abhinav Shukla on the research project, and for the friendship it has allowed us to form. He made the whole experience much more enjoyable, and his contribution to the work presented in this thesis is immeasurable.

My years at MIT have also forced me to grow as a person. In my time here, I have undoubtedly come across some of the brightest minds in the world, but I am happy to report that along with several of these minds, come caring hearts and warm smiles. It has been a pleasure to come to work everyday, and interact with my peers in the Production System Design (PSD) Laboratory. I would like to extend a word of thanks and congratulations to my fellow PSDers who will be graduating with me – Jorge Arinez, Brandon Carrus, Alex Chu, Deny Gomez, and Ania Mierzejewska.

I also owe a great deal of thanks to the following friends for holding me up when times were rough and for laughing alongside me when times were good: Richard and Morayma Guerrero, Lorenzo Lopez, Antonio Armendariz, Yamel Acosta, Marcos Herrera, Andre Brown, Andres Tellez, Detric Carter, Paula Valdivia y Alvarado, and Cristina Estrada. You are each very special to me in your own unique way.

Of course, I cannot leave out Nitza Basoco, Jeremiah Alderete, and Victor Morales, whom I knew for years before we ever thought of applying to MIT. I've already told each of you, on several occasions, how I could not have made it through the first years without you here beside me, but I figure saying it one more time can't hurt. Thank you!

It is so hard to describe in words, how much I appreciate the sacrifices my parents have made to provide me with, what many consider, the best education in the world. Mom, thanks for being there, and reminding me that I was always loved. And Dad, thanks for always staying on top of me, and forcing me to aim higher. Until just a few years ago, I could not understand why you were my harshest critic, but I now realize that it's only because you're also my number one fan. I hope to repay you both by living life to my fullest potential. As for Ricky and Yvette, my younger brother and sister, I love you both very much, and am very excited about your futures. I am also grateful for Naomi, my niece and newest addition to the family. She has brought so much life into our home, and fills me with joy each and every time I see her. I would also like to thank my grandparents, Alfredo and Adelaida Aguinaga. You both mean the world to me.

And last, but certainly not least, I want to thank Merlyn Flores, my girlfriend of eight years at this point, for sticking by me and providing me with a continuous source of love and inspiration. I will never understand why or how you put up with so much from me, so instead I simply thank you for it. You have always given me a reason to keep my head up and looking toward the future in which we would finally be together. We have dreamt many dreams together, and now it is time to go out and make sure they come true.

Table of contents

1	Overview of Coclisa Hose Manufacturing	10
1.1	INTRODUCTION	10
1.2	PROBLEM STATEMENT AND MOTIVATION	11
1.3	DEFINING MANUFACTURING AND PRODUCTION SYSTEMS	12
1.3.1	<i>Manufacturing System Breakdown</i>	<i>13</i>
1.4	WHY NOT JUST BUILD A BIGGER FACTORY?.....	14
1.5	THE CURRENT MANUFACTURING SYSTEM	15
1.5.1	<i>Current Layout of San Lorenzo Plant</i>	<i>15</i>
1.5.2	<i>Following an Aluminum Part through Fabrication</i>	<i>16</i>
1.5.2.1	Tube Cutoff.....	16
1.5.2.2	Tube Forming	19
1.5.2.3	Washing	21
1.5.2.4	Post- Wash Inspection.....	23
1.5.2.5	Brazing.....	24
1.5.3	<i>The Fabrication of Steel Tubes</i>	<i>27</i>
1.5.4	<i>Assembly Area.....</i>	<i>28</i>
1.5.4.1	Bending.....	28
1.5.4.2	Final Assembly Lines.....	29
1.6	SUMMARY OF THE CURRENT MANUFACTURING SYSTEM.....	30
1.6.1	<i>Scorecard of the current manufacturing system</i>	<i>32</i>
2	System Level Change: Where does one start?	34
2.1	A PROCESS PLAN FOR PRODUCTION SYSTEM DESIGN.....	34
2.2	STEP -1: DEMONSTRATE CELL FEASIBILITY	37
2.2.1	<i>Option 1 - "Fix" Existing Cells</i>	<i>37</i>
2.2.2	<i>Option 2 – Cell in Prototype Shop.....</i>	<i>38</i>
2.2.3	<i>Option 3 - Conversion of an Assembly Line.....</i>	<i>41</i>
2.3	CONCLUSIONS	41
3	Converting from Moving Assembly Lines to Cells	43
3.1	INTRODUCTION	43
3.2	MOVING BELT ASSEMBLY LINES.....	43
3.3	THE PRODUCT’S BASICS	44
3.4	STATE OF THE ASSEMBLY LINE, JUNE 1999.....	45
3.5	SIMPLIFIED “MASS” ASSEMBLY LINE DESIGN PROCESS.....	45
3.5.1	<i>Determining Belt Rate.....</i>	<i>46</i>
3.5.2	<i>Determining Operations’ Standard Times</i>	<i>47</i>
3.5.3	<i>Calculating the Number of Direct Workers</i>	<i>48</i>
3.5.4	<i>Calculating Belt Length</i>	<i>49</i>
3.6	DISCUSSION OF PROBLEMS OBSERVED ON THE ASSEMBLY LINE.....	50
3.6.1	<i>Conveyors Create the Need for Final Inspection.....</i>	<i>50</i>
3.6.2	<i>Lines are Never Truly Balanced</i>	<i>51</i>
3.6.3	<i>Loss of Predictability</i>	<i>52</i>
3.6.4	<i>Intentional Line Stoppages.....</i>	<i>52</i>
3.6.5	<i>Lack of Flexibility</i>	<i>52</i>
3.6.6	<i>No Concept of Continuous Improvement</i>	<i>53</i>
3.7	GOALS FOR THE CONVERSION TO CELLS	53
3.8	SIMPLIFIED CELL DESIGN PROCESS	54
3.8.1	<i>Defining Part Families</i>	<i>54</i>
3.8.2	<i>Determining Takt Time</i>	<i>54</i>
3.8.3	<i>Standardize Process and Operator Routine.....</i>	<i>56</i>
3.8.4	<i>Cell Testing: Is the Takt Time Met?.....</i>	<i>58</i>
3.9	COMPARISON OF QUANTIFIABLE MEASURES.....	60

3.10	DISCUSSION OF NON-QUANTIFIABLE BENEFITS OBTAINED THROUGH CELLS	60
3.10.1	<i>Ability to Balance Work Content</i>	60
3.10.2	<i>Workers' Attitude</i>	61
3.10.3	<i>Volume Flexibility</i>	61
3.10.4	<i>Predictable Output Exposes Problems</i>	62
3.11	CONCLUSIONS	62
4	Product Family Formation.....	64
4.1	INTRODUCTION	64
4.2	THE IMPORTANCE OF PRODUCT FAMILIES.....	65
4.3	WHAT PRODUCTS WILL RUN TOGETHER IN A SINGLE CELL?.....	66
4.4	CUSTOMER BASED PRODUCT FAMILIES.....	66
4.5	PROCESSING BASED PRODUCT FAMILIES.....	70
4.5.1	<i>Large Families</i>	70
4.5.2	<i>Subset Families</i>	74
4.6	ESTIMATES OF WORKER AND EQUIPMENT REQUIREMENTS.....	77
4.7	INTERIM PLAN	78
4.8	IDEAL PLAN.....	81
4.9	CONCLUSIONS	86
5	Changes Required to Achieve the Ideal Design.....	87
5.1	INTRO: AREAS OF CHANGE.....	87
5.2	NON-VALUE ADDING PROCESSES.....	89
5.2.1	<i>Leak Test</i>	89
5.2.2	<i>Post-Wash Inspection</i>	91
5.3	REDESIGN OF EQUIPMENT.....	93
5.3.1	<i>Tube Cutoff</i>	94
5.3.2	<i>Forming</i>	97
5.3.3	<i>Brazing</i>	99
5.3.4	<i>Bending</i>	102
5.3.5	<i>Crimping</i>	105
5.3.6	<i>Summary of Suggested Equipment Modifications</i>	106
5.4	CONVERSION OF REMAINING STEEL TUBES TO ALUMINUM.....	107
5.5	ORGANIZE PERSONNEL INTO PRODUCT FAMILIES TEAMS.....	108
5.6	CONCLUSIONS	110
6	References	111
7	Appendices.....	113
7.1	APPENDIX A: ESTIMATE OF DIRECT WORKER REQUIREMENTS	113
7.2	APPENDIX B: ESTIMATE OF EQUIPMENT REQUIREMENTS	114

List of Figures

Figure 1.1: Relationship between a production system and a manufacturing system [4].....	13
Figure 1.2: Design Levels of a Manufacturing System [3].....	14
Figure 1.3: San Lorenzo Plant: Layout of Current Manufacturing System.....	16
Figure 1.4: Aluminum spool loaded on tube cutoff machine	17
Figure 1.5: Formed end types	19
Figure 1.6: Steps required to form a ferrule end.....	20
Figure 1.7: Operator loading P-nut forming machine.....	21
Figure 1.8: Washing system used for removing oil from tubes.....	22
Figure 1.9: (left) Metal basket that holds parts during wash. The basket rotates inside of each wash station, and is moved automatically by an overhead joist. (right) Washer stations....	23
Figure 1.10: Post-Wash inspection	24
Figure 1.11: Different Braze Types	25
Figure 1.12: Rotary brazing machine used for aluminum parts.....	26
Figure 1.13: Schematic of brazing machine's 12 stations	26
Figure 1.14: Operator applying flux to steel tubes and loading conveyor oven for brazing	27
Figure 1.15: Dual-station bending machine.....	29
Figure 1.16: Final assembly line.....	30
Figure 2.1: Product families based on customers for simplified flow [10]	36
Figure 2.2: Layout of prototype shop with part flow.....	39
Figure 3.1: Connector between air conditioning components	44
Figure 3.2: Layout of the assembly line.....	46
Figure 3.3: Workers are idle for half of the assembly line throughput time.....	49
Figure 3.4: Layout of the two cells used to replace Line 4.....	56
Figure 3.5: Breakdown of final assembly operations	57
Figure 4.1: (left) Front view of crimping machine setup with dies in the open position. (right) Side view of dies in the closed position.....	68
Figure 4.2: Typical hybrid, 4 crimp model, in which the design objective is to change hose diameter between components of the climate control system.....	69
Figure 4.3: Different workloops used in a single assembly cell to produce the 4 hoses of the customer-based family. Black dot means the crimp machine is used in assembly of that hose.....	70
Figure 4.4: Large Families formed on the basis of material type and crimping.....	71
Figure 4.5: Product Family Tree. Highlighted levels show subset families with the third level representing the number of brazes and the fourth level the hose diameter.	76
Figure 4.6: General strategy for Linking Fabrication and Assembly Cells	82
Figure 4.7: Schedule for completion of the interim and ideal phases of conversion.....	83
Figure 4.8: Layout of Ideal System can be accommodated by assembly room at San Lorenzo plant.	84
Figure 5.1: Linked-cell subsystems pursued in the ideal plan. Arrows show part flow, while information is flowing in the opposite direction.	88
Figure 5.2: Conceptual design of a cellular washer	93
Figure 5.3: Orientation of spool with respect to the tension relief roller.....	95
Figure 5.4: Indexing and cutting mechanism of current cutoff machine.....	96
Figure 5.5: Straighteners at the start of the tube cutoff machine.	96

Figure 5.6: Suggested changes to the current forming machine design for the purpose of cell compatibility.....	98
Figure 5.7: Conceptual design for a cellular brazing machine.	101
Figure 5.8: Current design couples the indexing and rotating functions into a single jaw, and therefore cannot accommodate formed tubes.....	104
Figure 5.9: Proposed design for uncoupling rotation and indexing of the tube. Part is not linearly indexed, instead a jaw moves along the length to dictate bend location. Allows formed tubes to be bent.	104
Figure 5.10: Crimping machine	105

List of Tables

Table 1.1: Current System Attributes.....	33
Table 3.1: Final assembly work standard times.....	48
Table 3.2: Takt Time Calculations.....	55
Table 3.3: Comparison of Assembly Line 4 to Cells.....	60
Table 3.4 General Comparison of High Speed Lines and Cells.....	63
Table 4.1: Comparison of Hose for Single Vehicle.....	66
Table 4.2: Summary of Large Families.....	72
Table 4.3: Summary of Subset Families.....	77
Table 4.4: Comparison of the Current and Interim Systems.....	81
Table 4.5: Comparison of the Current and Ideal Systems.....	85
Table 5.1: Equipment Modifications Required for Use in Cells.....	106

1 Overview of Coclisa Hose Manufacturing

1.1 Introduction

In June of 1999, the Production System Design (PSD) Laboratory at MIT teamed up with engineers and production managers from Coclisa S.A. de C.V. to design the ideal production system for a new plant that was yet to be built. The new plant would be responsible for manufacturing the hoses used in automobile air-conditioning systems. The term *ideal* is used since the design being sought embodied fundamental “lean” concepts, while respecting current constraints of the company. Moreover, the process of designing a truly “lean” plant is one of continuous improvement, and a key objective of the ideal design was to create a plant that allows itself to change easily as financial resources become available and the business grows.

From a research standpoint, the opportunity to design an entire production system in a near-greenfield situation was an excellent opportunity for PSD to test many of the design tools and approaches it has been developing over the past several years. In most instances, PSD has pursued its research within existing mass production systems, and thus has only been capable of affecting specific, relatively small areas of a larger system. Also, the constraints imposed by a mass system often make it difficult to distinguish whether the issues of the area undergoing change were a result of the constraints or the quality of design and implementation of change. Is the lean component being implemented the best solution? If not, is it a failure of lean production concepts or is the problem rooted in the fact that the lean component is embedded in a larger system with which it is not compatible?

The near-greenfield situation, at the Coclisa site, minimized the influence of such factors, and allowed easier evaluation of the new production system. Among the approaches tested were

those put forth by Prof. David S. Cochran [9] for the design of entire lean production systems, as well as the cells that make up these systems. In both cases a list of recommended steps to pursue were offered. The first question to address was the appropriateness of each step. Then, it was important to test the completeness of these lists to ensure no steps were overlooked and that the list was generic enough to be applicable in all situations.

1.2 Problem Statement and Motivation

Coclisa, a member of Visteon's Climate Control Division, is a manufacturer of air-conditioning radiators, compressors, condensers, and connecting hoses. Its operation, located in Ciudad Juarez, Mexico, is spread out over 4 separate plants with the San Lorenzo plant being the primary facility for hose manufacturing. However, this plant is not capable of accommodating all hose production. As a result, production has moved into two other plants -- the first of the "spillover" plants handling fabrication, the second doing final assembly. Along with the obvious problems that arise by having production split over three facilities, there is also a need to take hose assembly out of the second spillover plant by July of 2000. This move is necessary to make room for production of a new compressor.

Coclisa's solution was to construct a new building that is large enough to hold all hose manufacturing and could offer several amenities that are not available in the current facility. The construction of a new building offers several possibilities for reorganization of the manufacturing operation, and thus, is an excellent opportunity to investigate the design of an ideal "lean" plant. It was at this point that MIT's Production System Design (PSD) group was asked to assist.

Along with the design of the ideal factory, Coclisa was also interested in knowing which of its current equipment would be useable "as is," which could be retrofitted, and which needed to be replaced. As Mark Winters, the plant manager, put it, "Since every piece of equipment we

own needs to be picked up and moved, it's a good time to figure out what is worth keeping and what can get left behind." Most importantly, knowing that things would not happen overnight, Coclisa wanted a detailed plan for getting from their current situation to the ideal.

The work presented here took place on-site at Coclisa, and covers the several steps that were taken to reach interim and ideal designs. While it focuses on the technical aspects of manufacturing system design as they pertain to the project being pursued at Coclisa, the fact that the work took place on-site, rather than behind a desk elsewhere, presented a unique set of situations. These situations stem mostly from peoples' attitudes and perceptions of the design work. They played a significant role in the design process, and are a large part of the "real world" that design tools are unable to capture.

1.3 Defining Manufacturing and Production Systems

Based on the distinction Black [1] makes between a manufacturing system and a production system, Cochran and Dobbs [11] propose the following definitions:

- **Manufacturing system:** The arrangement and operation of machines, tools, material, people and information to produce a value-added physical informational or service product whose success and is characterized by measurable parameters
- **Production system:** the supporting elements of the manufacturing system including the performance measurement system.

The manufacturing system is the part of the plant directly involved in physical production, while departments such as accounting, production planning, quality control, and engineering are the support cast and comprise the production system. Figure 1.1 shows the relationship between the manufacturing system and production system.

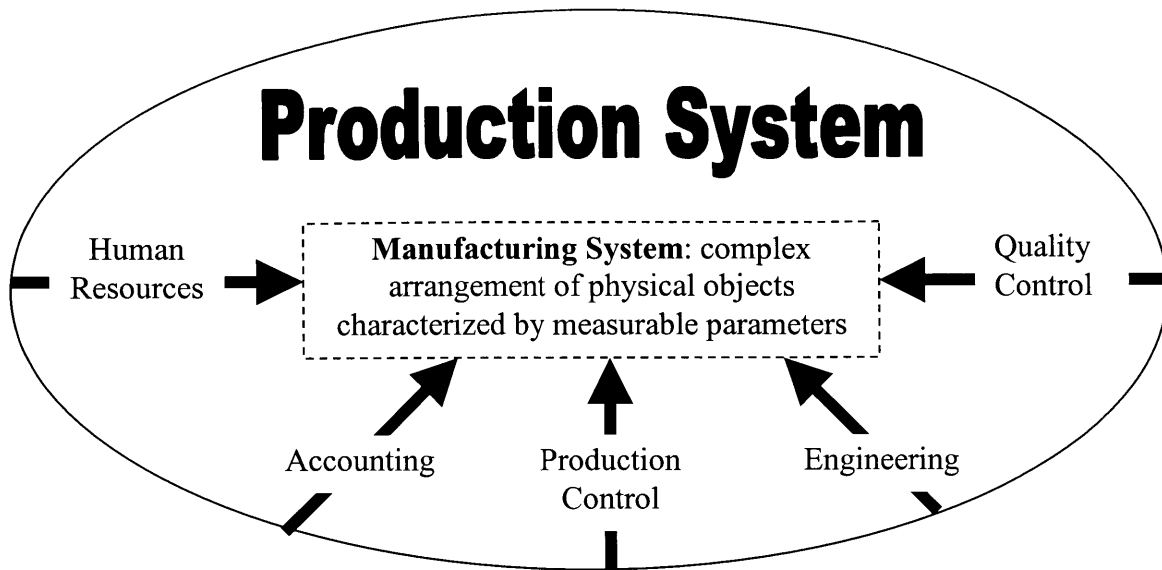

Figure 1.1: Relationship between a production system and a manufacturing system [4]

1.3.1 Manufacturing System Breakdown

Manufacturing system design takes place at three levels starting with the system level, leading to the sub-system level, and finally the unit level. Figure 1.2 attempts to capture the three aspects of manufacturing system design. As one moves down the levels the scope becomes more specific. Decisions made at the lower level should be in line with the goals of the level above it. Once a design decision is made at a lower level, the levels above have to be adjusted to account for the decision. Thus, the higher levels are continually fine tuned in response to the discoveries and decisions made at the lower levels, allowing rough designs to become more detailed.

At the system level, questions must be answered regarding criteria for forming product families, information flow between cells and the final customer, and the strategy for linking fabrication and assembly. Once a system-level picture is painted, the subsystem level focuses on the specifics of designing individual cells, which are the building blocks of a lean manufacturing system. While it is feasible to design base models for the general types of cells, it is essential that

cells are designed individually since each will present a unique set of constraints that will in turn affect the end design. At the subsystem level, the design choices pertain to Takt time, cell layout, the number of workers per cell, operators' standard work routines, and the cell design allowing volume flexibility. At the unit level, attention is placed on designing or retrofitting the machines to be right-sized. Right sizing mainly deals with the machine's cycle time being able to meet takt time, its overall physical size and its ability to stop automatically if a problem is detected.

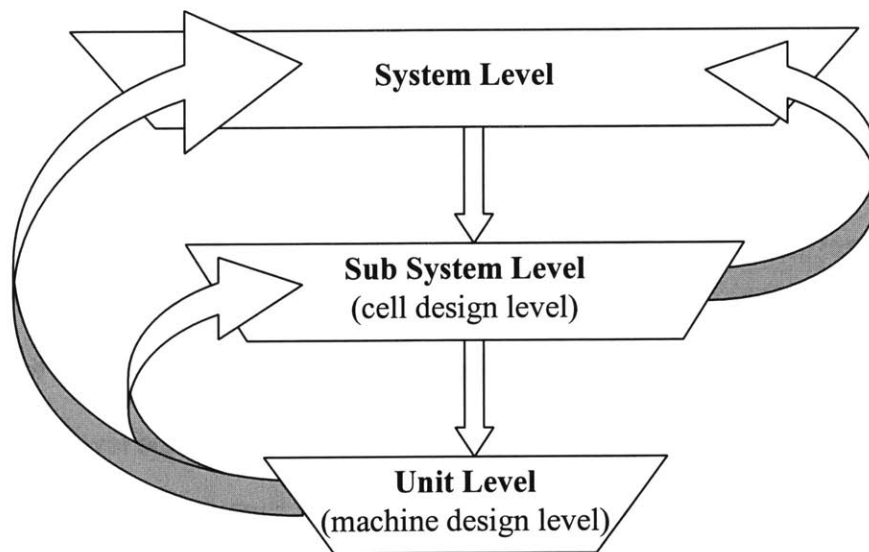

Figure 1.2: Design Levels of a Manufacturing System [3]

1.4 Why Not Just Build a Bigger Factory?

In planning the size of a new facility, Coclisa could have taken the sum of the production area currently utilized at the three different plants and added an allowance for forecasted business growth. In this way, once the new building is complete, transferring the manufacturing system is simply a matter of relocating equipment. The benefits of this approach are that no time is lost making a new system work and no additional money is spent on equipment investment.

While this logic might suffice elsewhere, Coclisa's hose manufacturing operation is plagued by several problems, besides limited floorspace, which are being addressed by

redesigning the manufacturing system. The major issues that require attention are: high throughput time, quality problems, and processing methods. These problems are deeply rooted in the design of Coclisa's current manufacturing system, and are not a consequence of a lack of space. Coclisa's departmental, mass production system approach to manufacturing hoses is the cause for most of its persistent production problems. There are several principles regarding why mass systems do not work as well as lean system [5, 11], which will be developed in this thesis.

1.5 The Current Manufacturing System

To describe Coclisa's current manufacturing system, this section will follow a part through the entire system, highlighting the relevant details within each department. This virtual plant tour will give a better overall picture of why various problems have arisen throughout the system. The description should serve as both an introduction to the workings of a typical mass system, and also as a reference for future comparisons with the ideal design.

1.5.1 Current Layout of San Lorenzo Plant

Upon entering the San Lorenzo plant, one immediately notices a wall running the width of the plant, separating the final assembly processes from the fabrication processes. On the fabrication side of the wall there are two distinct paths parts follow depending on their material type. Aluminum tubes are washed, then go to rotary braze machines, and are then taken to the assembly side of the manufacturing system. Steel parts tend to have more complicated brazes and require parts to be press-fitted prior to being brazed. This department is shown as the "Steel Subassembly" in Figure 1.3. Brazing of steel parts is then done on a conveyor oven rather than rotary machines. The last difference in these two paths is that the steel parts leave the plant for anti-corrosive plating by an outside supplier. Once the tubes reach the assembly side, their paths are identical as they get bent and then sent to the final assembly lines. Of all tubes being

fabricated, 70% are aluminum and 30% are steel. Steel tubes are being phased out because they are heavier and require extra processing.

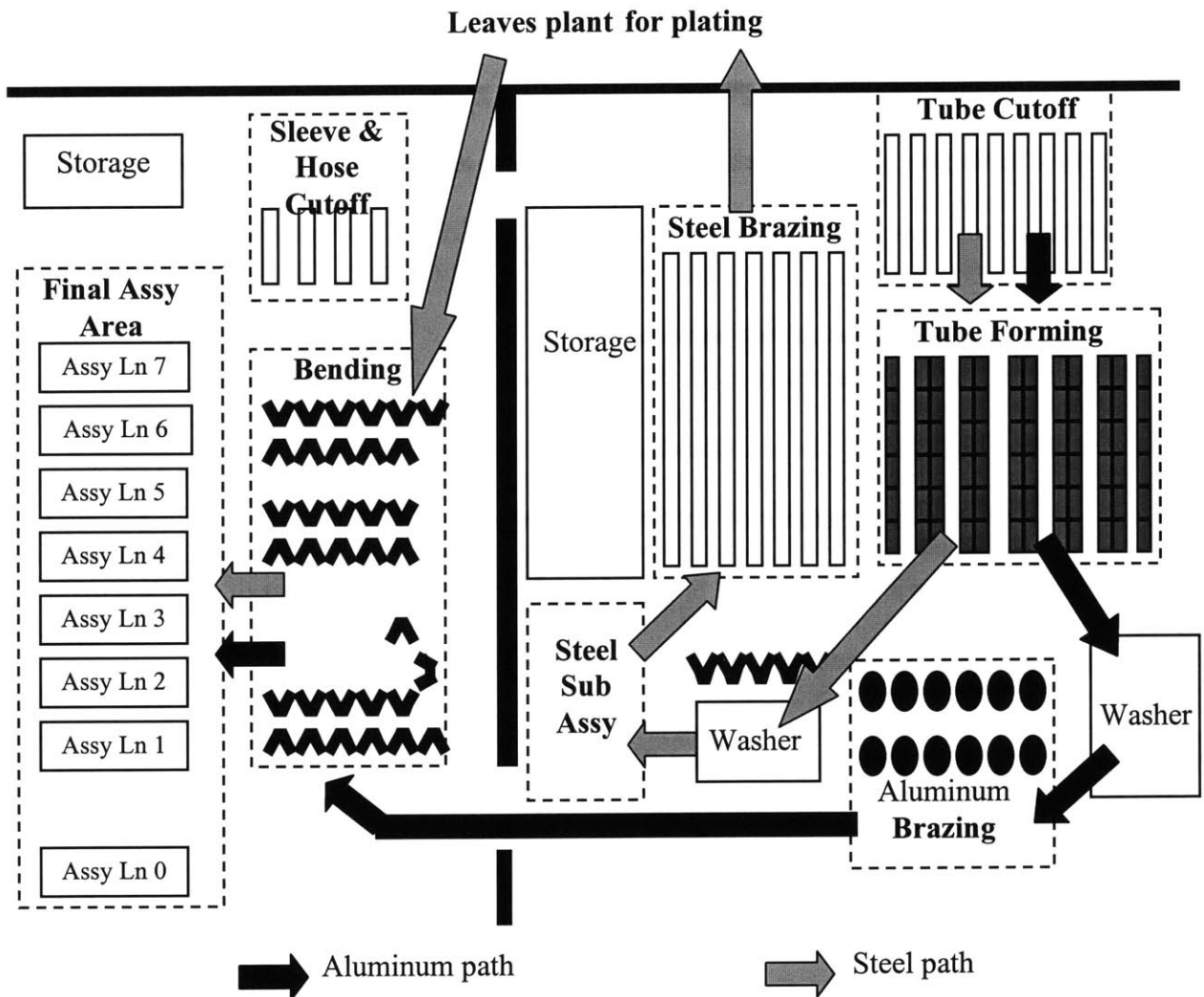

Figure 1.3: San Lorenzo Plant: Layout of Current Manufacturing System

1.5.2 Following an Aluminum Part through Fabrication

1.5.2.1 Tube Cutoff

As shown in Figure 1.4, aluminum tube stock comes to the plant on spools, which are loaded onto cutoff machines. Once loaded, the machine will automatically index to a preset length, cut, and repeat the process for the desired number of cuts. Having the material on a spool minimizes the number of times the machine must be loaded. But, in order for the machine to

pull the stock from the spool, a great deal of oil is applied to reduce friction between the aluminum and the nylon roller used for tension relief. Thus, even prior to the first processing step, the aluminum tubes are covered in oil over the entire length, which creates the need for the washing operation downstream.

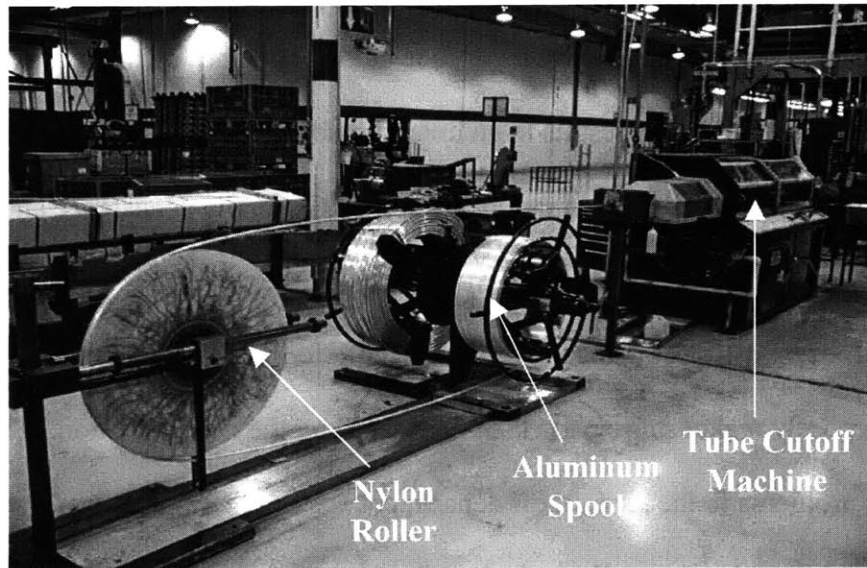

Figure 1.4: Aluminum spool loaded on tube cutoff machine

Another difficulty encountered in the tube cutoff area is scheduling. As well as there being several different tube lengths, there are also four tube diameters so the various combinations of cut tubes required are numerous. However, once a machine is loaded with a certain diameter stock, parts are cut until the spool runs out, rather than loading and unloading spools of different diameter. This practice usually leads to more parts being cut than needed.

A second factor compounding the scheduling problem is the number of cutoff machines available. The number of machines available is directly related to the machine's cycle time of 2 to 4 seconds (depending on the tube's cut length). As Cochran [6] suggests, in mass systems the typical calculation used to determine the number of machines needed per department is the following:

$$\text{Number of Machines} = \frac{\text{Aggregate Production Demand Rate [total parts required/minute]}}{\text{Machine Production Rate [parts produced/min]}}$$

where Machine Production Rate is the inverse of the machine's cycle time. However, since aggregate demand is used in the calculation, no allowances are made for the changeovers required to meet production exactly.

Another factor that makes scheduling of tube cutoff machines difficult is quality loss. The variation that causes quality loss results in an unpredictable degree of scrap, and makes it difficult to accurately produce a given number of parts. Given the persistence and unpredictability of scrap being produced at this operation, the current system deals with the problem by purposely overproducing. Overproducing refers to the situation in which a department purposely makes more parts than demanded by the next operation. These root causes for scheduling problems in the tube cutoff department are common in most of the other departments as well, and are actually typical attributes of a department within any mass system.

There is one worker per machine in the tube cutoff department. One person per machine, regardless of the machine's function, is another common feature of mass systems. The operator takes cut tubes from the machine's output bin, visually inspects the length of the tubes relative to each other, and then packs the tubes into bins for transport to the tube forming department. Moreover, there is no standard size for batches being transported between departments. Rather the worker at cutoff machine fills a bin with as many parts as possible (which is a function of tube diameter, tube length, and the worker's judgment) then moves it on.

While the batch size is not standard, a conservative estimate of the number of pieces in a batch is about 200, for tubes that are less than a foot in length. The result of working with such large batch sizes is increased throughput time due to the variable described as lot delay. Lot delay describes the time loss associated with every part having to wait on every other part in its

batch to be processed before being advanced to the next operation. In any production system, lot delay is viewed as waste since the first part of the batch could have been advanced to the next process immediately after being cut, but instead waits for all other parts in the transfer batch. During this period no value is added to the part, and overall throughput has been significantly increased. Worse yet, response time to defects is directly proportional to the batch size. Thus, if a defective part is detected in the next department, there is a high probability that many other parts in the batch are also defective.

1.5.2.2 Tube Forming

In this department, both ends of the tube undergo a series of forming processes to make different end geometries. Any end that will eventually be crimped to the hose gets a ferrule forming, while ends that do not connect to the hose may receive either an end cage or P-nut end form. Figure 1.5 shows examples of the different end types that are formed.

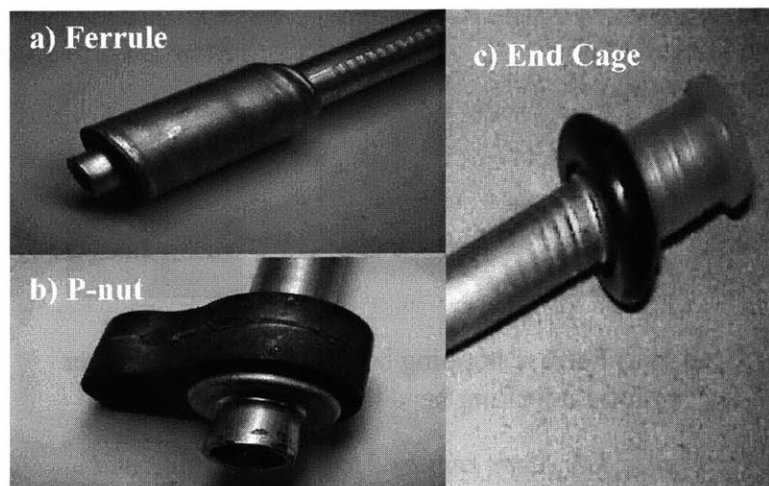

Figure 1.5: Formed end types

In ferrule forming, up to four separate machines are used, with each having approximately a six second cycle time. Given that the metal is being cold-worked, oil is again applied to the tube. In this department, each operator simply dips the tube end in an oil reservoir before

feeding it into the machine. Due to this technique for oil application, the tube's interior also gets coated with oil, and further complicates the task of washing.

The first of the ferrule forming machines reduces the tube's diameter from the end to about an inch inward. It may be necessary to use a second reduction machine depending on the product's design. The next machine forms V-grooves on the tube's end to make the task of slipping the hose over the tube end easier in final assembly, and also to grip the hose should the end product be subjected to tension. The last machine actually places the ferrule over the tube end, and is referred to as a 3-stroke machine since it makes use of 3 different dies to complete the process. The first die forms a bead on the tube that acts as a stopper, the next die pushes the ferrule over the end up to the stopper, and the last die forms a bead inside the ferrule to lock it in place. Figure 1.6 summarizes the steps involved in forming the ferrule end.

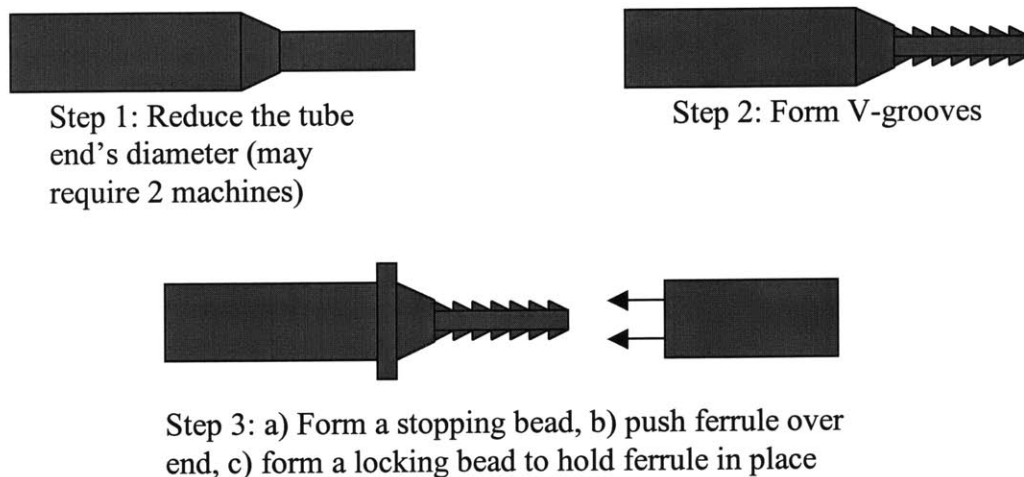

Figure 1.6: Steps required to form a ferrule end

The steps required for P-nut forming are identical to those used for ferrule forming, however, all the steps are done on a 6-stroke machine that has incorporated all the necessary dies onto a single machine. At this time, the geometry of some P-nuts does not allow them to be formed. Those particular P-nuts are instead joined to the tube by brazing.

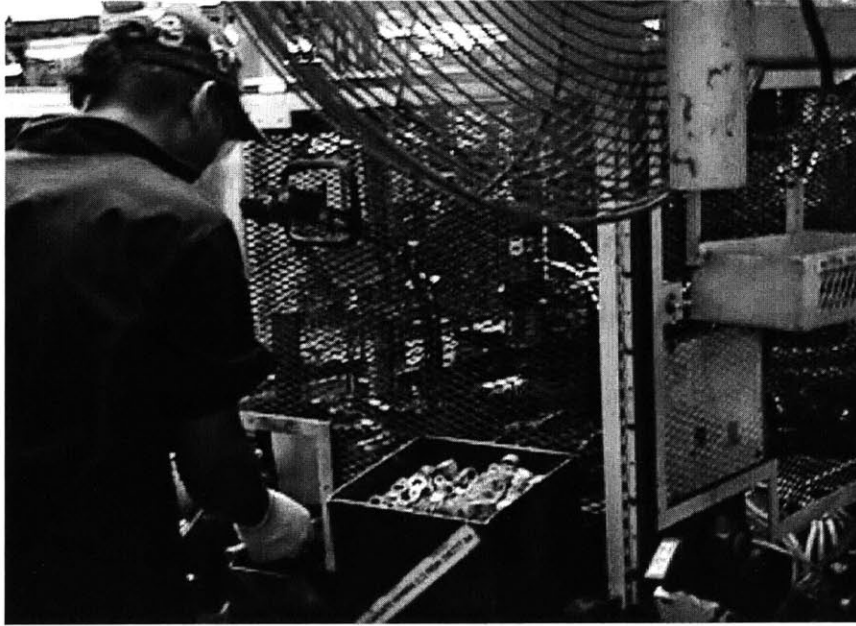

Figure 1.7: Operator loading P-nut forming machine

The forming of an end cage is also similar to ferrule forming except that no diameter reduction is necessary. Thus, only two machines are needed for attaching an end cage to the tube. First, a 3-stroke machine is used to form a stopping bead, push the end cage over the end, and form a locking bead, and then a grooving machine. The grooves serve a different function on the end cage end, and are straight as opposed to being V-shaped.

1.5.2.3 Washing

The current system's first two departments are value adding, which means that the process changes the product in a way that the final customer values and is willing to pay for. However, the same cannot be said of washing. The need to wash is a direct result of having to remove the oil used in tube cutoff and end forming. While all tubes require some level of washing, for those parts that require brazing, washing is a critical process. If the parts are not properly cleaned, the braze may be porous and hence very weak.

The size and design of the current washers is largely dictated by 1) each tube being contaminated with oil over its entire length on both the exterior and interior, and 2) the batch size of parts to be processed. Washing is done in 4 stages – pre-soak, detergent bath, rinse, and dry. In order to wash the tubes, bundles of about 200 are loaded into a large metal basket, and then within each of the first three stages the metal basket is introduced into the bath and rotated by an overhead joist. The washing system, shown in Figures 1.8 and 1.9, has two major problems. First, it is not a capable process since some parts remain oily after passing through the washer. Worse is the fact that the problem usually goes undetected until brazing. Secondly, the washing process causes damage to a high number of the tubes. The damage is the result of the tubes being loosely packed to allow the washing fluid to circulate as the basket rotates. While the loose packing leads to better cleaning, it also means that the tubes are constantly banging against each other and the walls of the basket, which causes deformation and scratching.

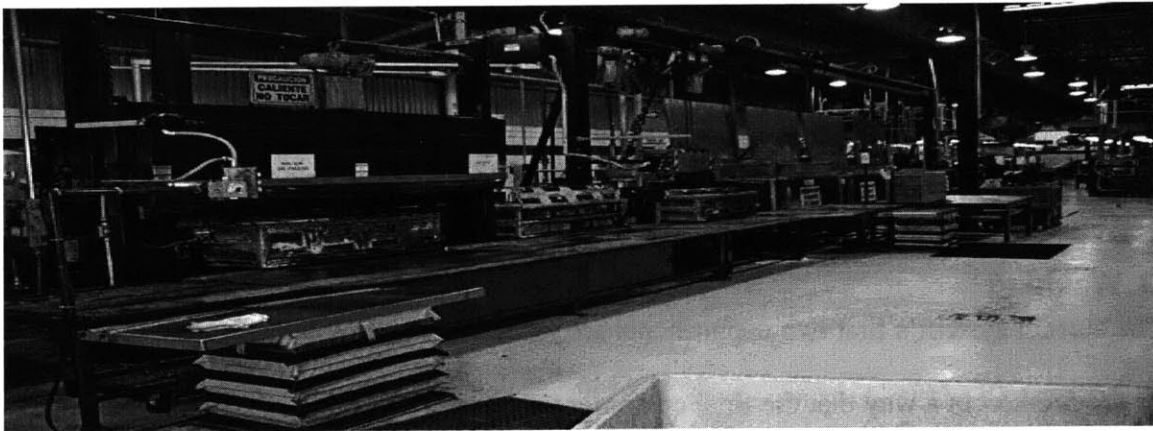

Figure 1.8: Washing system used for removing oil from tubes

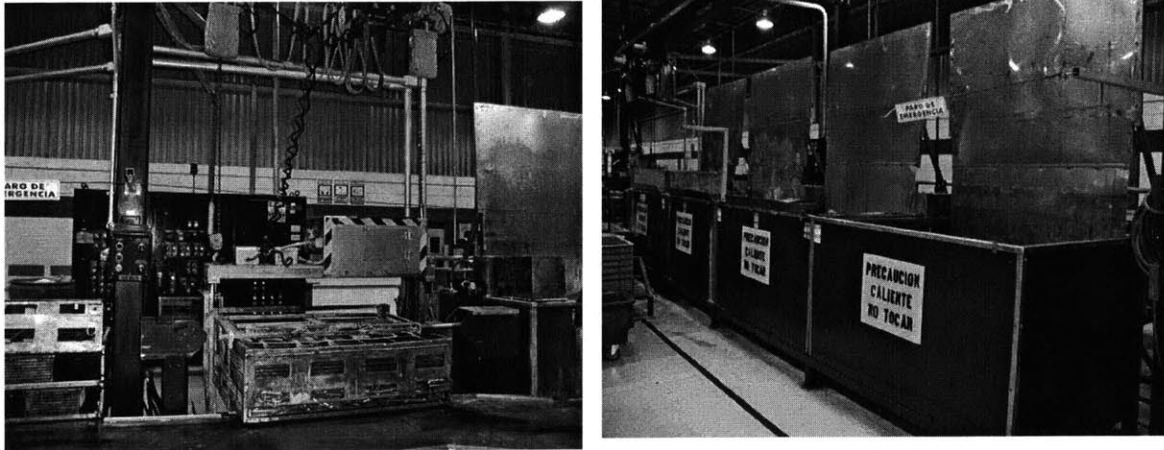

Figure 1.9: (left) Metal basket that holds parts during wash. The basket rotates inside of each wash station, and is moved automatically by an overhead joist. (right) Washer stations.

1.5.2.4 Post-Wash Inspection

Figure 1.10 shows the post-wash inspection station, which requires four operators to visually inspect all parts leaving the washer. Given the large number of tubes the inspectors have to look through, they often choose to inspect about ten parts at a time (or a quantity based on how many they can hold in their hands). The problem associated with the current work method, inspecting several parts at one time, is that defects are overlooked. However, the more serious problem with washer-related defects is that they come after a significant amount of tube fabrication has already taken place.

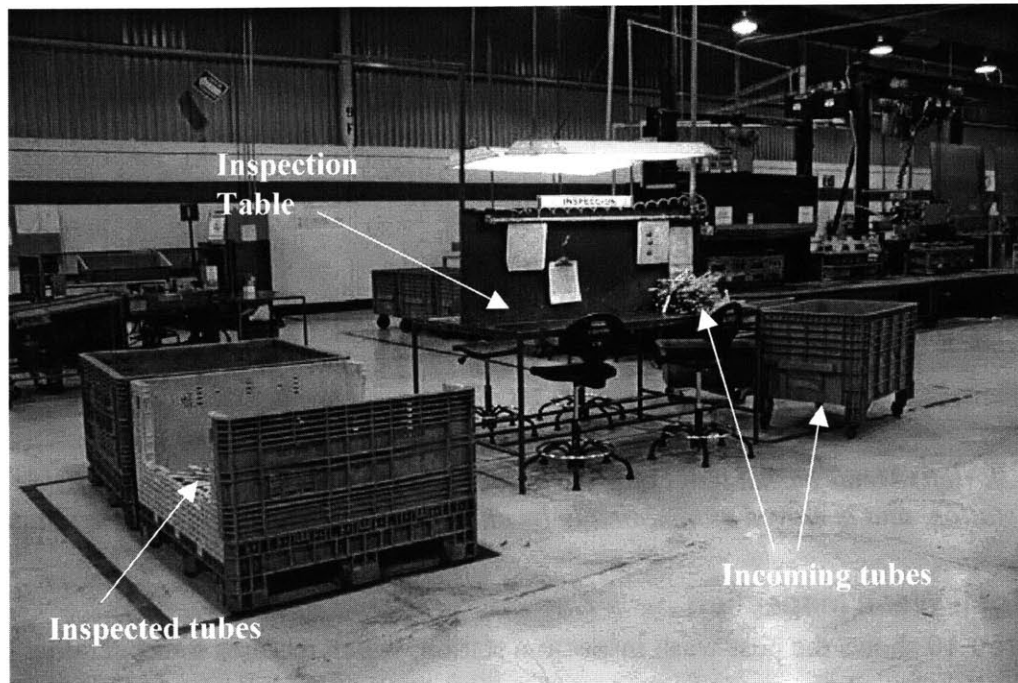

Figure 1.10: Post-Wash inspection

1.5.2.5 Brazing

Brazing is necessary when the geometry of the parts do not allow joining by forming. For instance, forming can only be used at the tubes' ends, while some designs require the joining of tubes along their length. For aluminum tubes there are 4 typical braze types made which include saddle, stem adaptor, charge valve, and P-nut. A saddle braze joins the end of one tube along the length of another tube, forming a T-shape. This braze type gets its name from the lip formed on the end of the tube which conforms to the second tube's exterior shape and resembles a saddle. A second braze type is called the stem adaptor. In this case, the braze is such that the adaptor is inserted along a tube's length. The last two braze types, the charge valve and P-nut, are joined to the end of the tube. Figure 1.11 shows the difference in the braze types, while the brazed P-nut is shown in Figure 1.5.

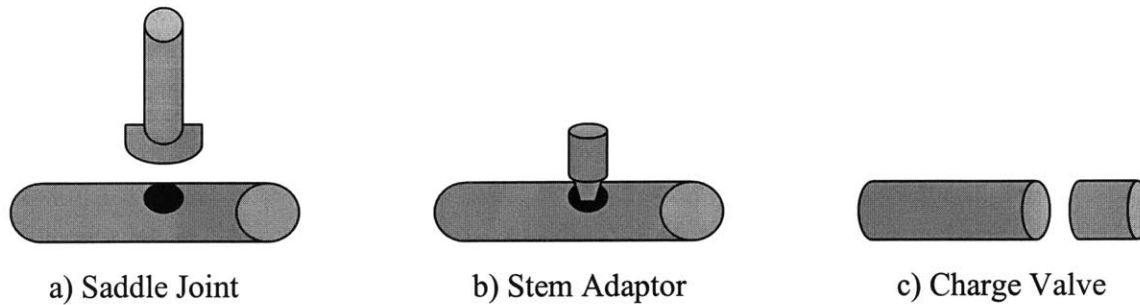

Figure 1.11: Different Braze Types

The aluminum brazing machine, shown in Figure 1.12, has two workers tied to it, one for loading the parts onto the fixture and the other for unloading the brazed parts. The cycle time of each machine varies between 9 and 11 seconds depending on the type of braze being run. As a result of the fast cycle time, the brazing machines each have a continuous rotary turntable with 12 stations. The number of stations utilized is based on the heating and cooling times required for a given braze. For example, a P-nut braze requires 25 seconds of heating in order to achieve an acceptable braze joint. Thus, with a 9 second cycle time, heating takes place over three stations. Figure 1.13 shows a schematic of the twelve stations that make up the braze machine.

On any braze machine only one part type is being run, and thus there are identical fixtures at each of the twelve stations. Moreover, the fixtures for various part types are custom built based on braze type and tube geometry. While the storage of these fixtures takes up floor space, the larger issue at hand is that of changing over between models. The task of removing each fixture and replacing it with the new one takes about 20 minutes. The process of adjusting parameters to account for the new tube geometry and heating requirements of the braze type is not standard. Consequently, several parts are run before the first good part is obtained.



Figure 1.12: Rotary brazing machine used for aluminum parts

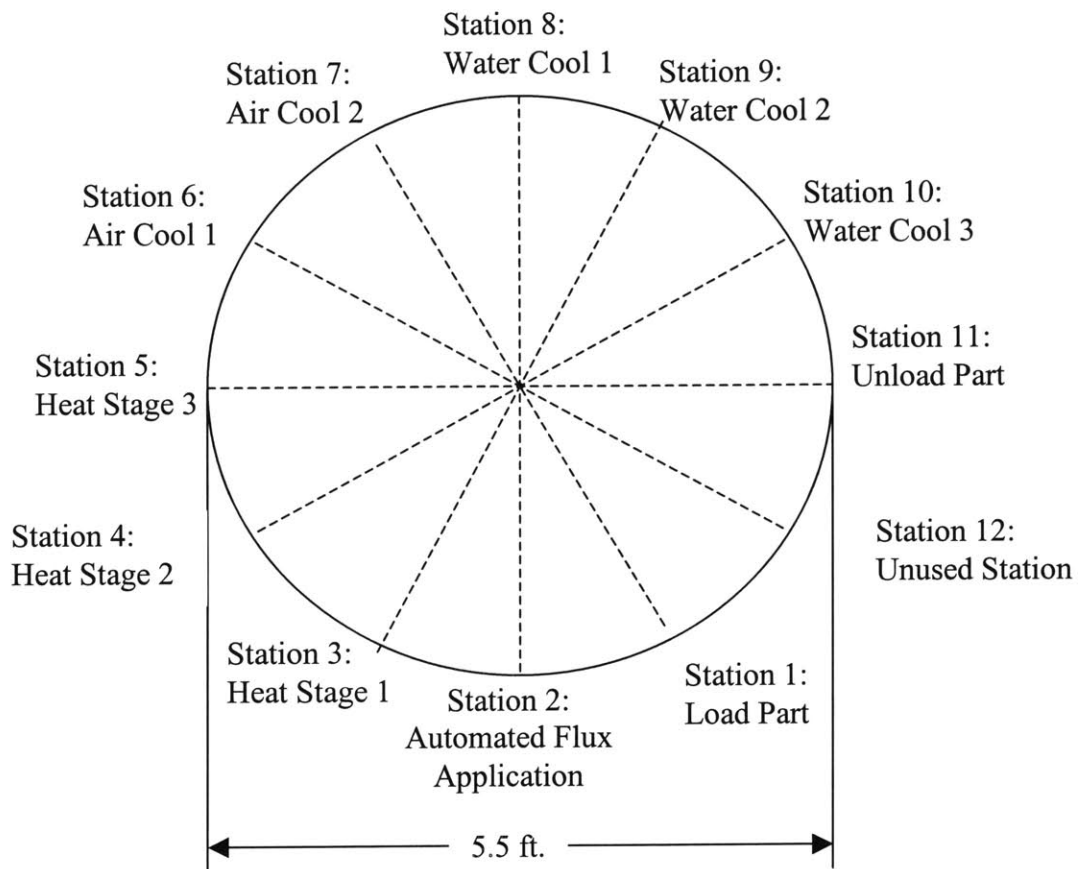

Figure 1.13: Schematic of brazing machine's 12 stations

1.5.3 The Fabrication of Steel Tubes

Fabrication of steel tubes is a process identical to that of aluminum tubes up to the brazing process. After post-wash inspection, the steel tubes go to a subassembly area, where the parts to be brazed are press fit onto the tubes, before being sent to brazing. Press fitting is necessary since the brazes being made to the steel tubes are more complex than those on the aluminum tubes; also any one steel tube may have several braze joints, while the aluminum tubes typically have a maximum of two.

Given the complexity and number of braze joints, the task of applying flux is not automated, but instead is applied by the worker. After applying flux, the operator then places the tubes on a conveyor oven where they will be brazed. Since the brazing of steel requires higher temperatures and longer heating times, the rotary design used for aluminum is not feasible. The oven used for steel brazing is shown in Figure 1.14.

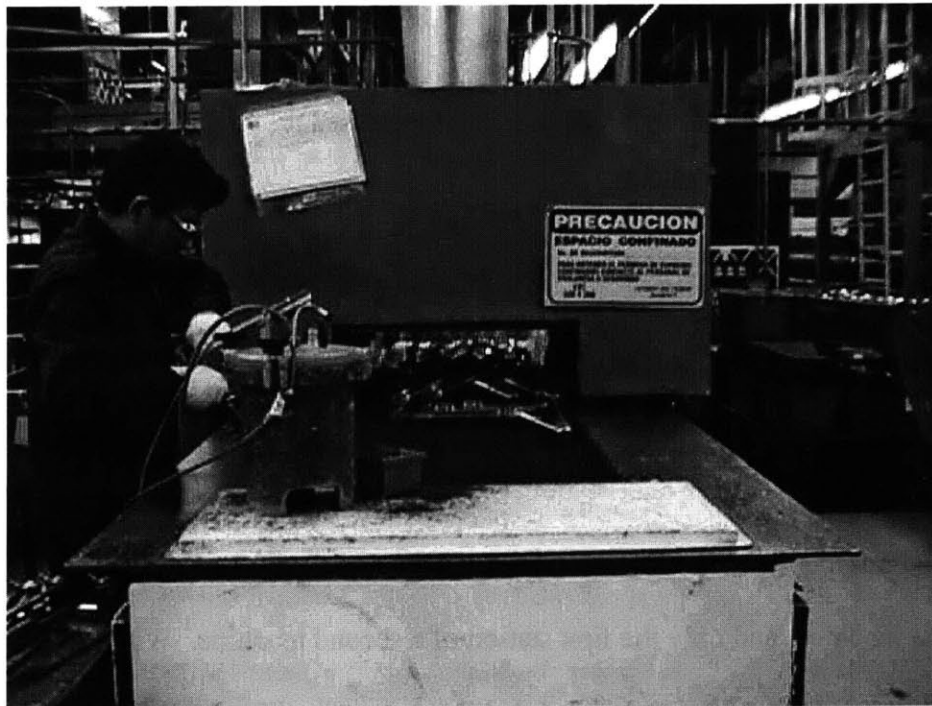

Figure 1.14: Operator applying flux to steel tubes and loading conveyor oven for brazing

After brazing, the steel tubes leave the plant for a plating process that is performed by an outside vendor. Even though the vendor is local there have been problems with return of the steel tubes when expected, leading to an array of production problems. Thus, Coclisa has chosen to carry a large inventory of plated steel tubes, in order to lessen the effects of the vendor not delivering on time. However, carrying inventory is far from ideal in manufacturing since it hides quality problems, ties up capital, and physically takes up a great deal of floor space.

1.5.4 Assembly Area

The assembly side of hose production consists of two departments, bending and final assembly. In both of these departments steel and aluminum follow identical paths. The final product may be composed entirely of aluminum tubes, entirely of steel tubes or a combination of the two, which are known as hybrids. Therefore, the equipment used in assembly is capable of handling both material types.

1.5.4.1 Bending

In the bending department, the machines bend the tubes through the use of impact dies. All machines have one operator tied to them, whose task is to load two stationary dies with tubes. Once loaded, the operator activates the machine and the impact dies come down bending both tubes simultaneously. See Figure 1.15.

Tubes can require anywhere from one to ten bends to attain the desired final geometry. However, since all machines are dual-station, several machines have an idle station when a tube requires an odd number of bends. For example, a tube requiring 3 bends, will pass through both stations of one machine, and only the first station of a second machine. With only one worker, activating both stations, it has been decided that it is better for the station to sit idle rather than complicating the operator's task by introducing a second tube type.

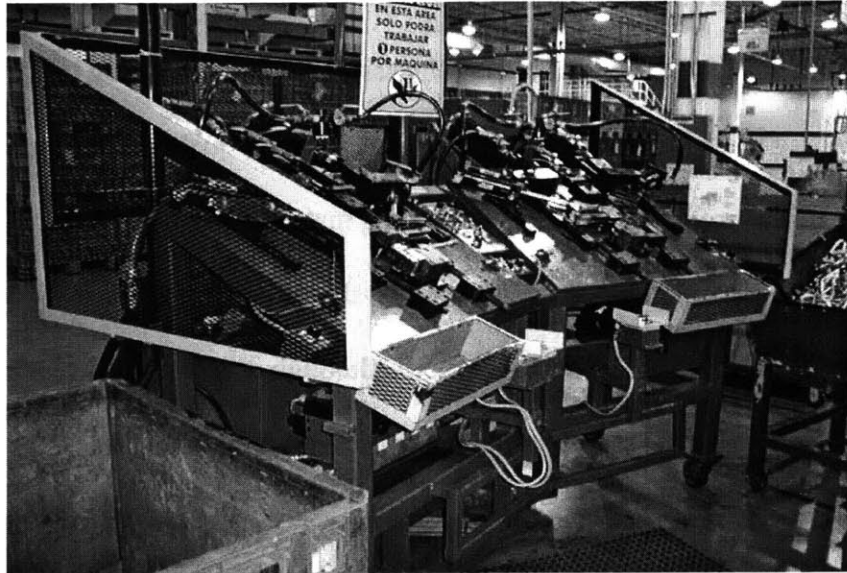

Figure 1.15: Dual-station bending machine

Another problem with the current bending machines is their lack of flexibility. Every tube bend requires its own special set of dies, with a set costing on the order of \$10,000. Moreover, changeover becomes an issue since the task takes on the order of twenty minutes. Instead, large batches are run to reduce the number of changeovers.

1.5.4.2 Final Assembly Lines

After passing through all other departments, the tubes reach moving-belt assembly lines and are assembled to rubber hoses for construction of the end product. A typical assembly line is responsible for the production of about 3,000 to 4,200 parts a day, which is equal to a cycle time of 6.2 to 8.7 seconds. Given that final assembly has been designed to run at such a short cycle time, the work is greatly subdivided. As a result, the assembly lines measure close to 100' in length, and the number of workers per line ranges from 18 to about 30 depending on the complexity of the hose being assembled.

The operations that take place on the line are inspection of the tubes, attaching O-rings, crimping of the tubes to the hoses, leak testing the assembly, and preparing the product for shipping by attaching protective caps to the tube ends. Several quality problems exist in final assembly. Some of the problems are due to incoming material from fabrication. Other problems are caused by the abusive handling of the material on the line itself in which the operator tosses the part back on the conveyor after each operation. Although it is difficult to see much detail, Figure 1.16 gives an idea of the massive size of a typical final assembly line.

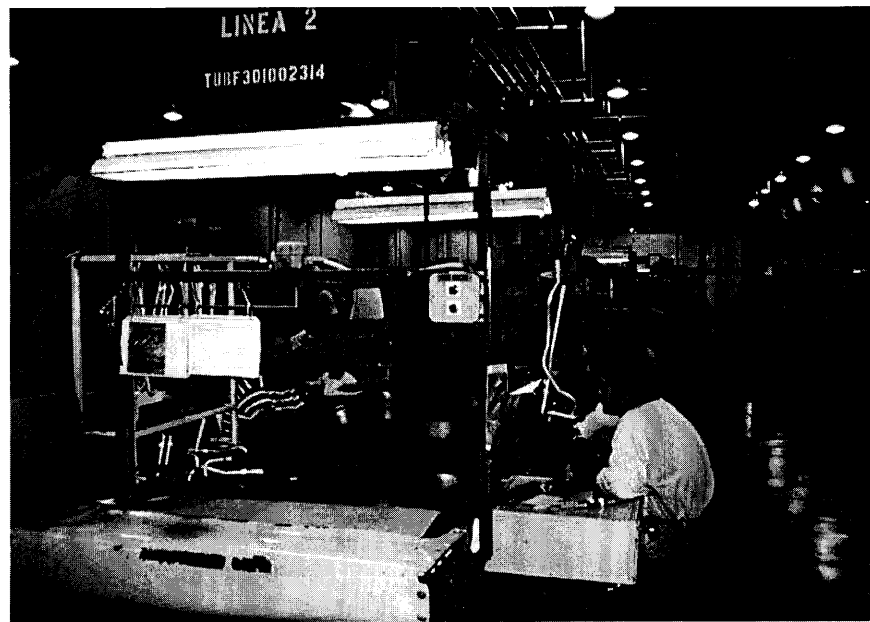

Figure 1.16: Final assembly line

1.6 Summary of the Current Manufacturing System

In any manufacturing system, operations can be classified into one of the following: processing, inspection, storage, and transport [4, 18]. Of these, only processing may be a value-adding operation, where value adding is defined as changing the form or function of a part to a state the final customer is willing to pay for. For example, customers will pay for hoses that do not leak. However, while inspecting the hoses for leaks may ensure a quality product, the act of

inspection adds no value. By using this same definition of value-adding, it may also be found that some processing is unnecessary.

In any case, all manufacturing systems require some amount of inspection, storage, and transport, reduction of these non-value adding operations and improvement of value adding operations should always be sought. Thus, while each operation of the current manufacturing system can be analyzed individually and stripped of its non-value adding components, many problems are the direct result of departmental system design. Therefore, when seeking improvements to individual operations the following system-level goals should be observed:

- simplify product and information flow throughout the plant by forming a linked-cell manufacturing system,
- reduce throughput time by eliminating lot delay with single-piece flow,
- eliminate the waste of transport and storage delay by moving manufacturing processes adjacent to each other and designing the processes to operate at the customer takt time,
- prevent the occurrence of defects by integrating quality control into the station design,
- separate the workers from the machines to effectively utilize direct labor, while ensuring single-piece flow, and
- reduce the time and complexity of machine setup by designing the machines to system takt time (not high speed to reduce labor cost) and by eliminating the need for adjustment during setup.

Achieving these general goals will lead to higher quality, lower inventory (which translates into lower cost), and thus, increased customer satisfaction. The new manufacturing system

design being proposed accomplishes each of the above goals through several different means. For example, simplified product and information flow is largely dependent on the proper formation of product families (discussed in Chapter 4). Similarly, the reduction of throughput time, the reduction of transport and storage delay, and increased worker utilization are achieved by the formation of cells that promote single-piece flow and multi-functional workers (discussed in section 3.8). Lastly, the redesign or modification of equipment to make it compatible for use in cells is discussed in section 5.3. The new manufacturing system design only focuses on the processing of aluminum tubes, which account for 70% of all tubes. Steel tubes, which make up the remaining 30%, are rapidly being phased out, and their inclusion in the new design was not deemed worthwhile.

1.6.1 Scorecard of the current manufacturing system

Table 1.1 offers a summary of the current manufacturing system's objective measurables.

Objective measurables are defined by the following two characteristics:

1. being unanimously agreed upon (not subject to debate), and
2. being quantifiable.

The table is intended to give an appreciation for the size of the overall operation by presenting the number of machines and people that make up the system. Measures such as throughput time and scrap will become important in a later comparison of the new system design.

Table 1.1: Current System Attributes

Features		Current Mfg System
Production		~7,000,000 pcs/year
Floor Space (sq. ft)		163,140
Total Direct Workers (all shifts)		1052
Total Indirect Workers (all shifts)		175
Total required man-hours per year		2190195
Fab Production	a) Machine cycle time	b) Number of machines
tube cutoff machines	2-4 sec (length dependent)	10
formers (3 stroke)	6-8 sec	56
formers (6 stroke)	6-8 sec	23
groovers (ferrule)	6-8 sec	21
groovers (end cage)	6-8 sec	4
piercing machines	2 sec	13
washers	~ 30 min	5
Aluminum brazers	9-11 sec	16
Yearly Fab Scrap Expenses		~ \$540,000
Fab WIP		variable (~ 64,000)
Fab Throughput Time		variable (~1 day)
Assy Production	a) Cycle time	b) Number of machines
assembly lines	6.2 – 8.7 sec	12
bending machines	4 sec	132
crimping machines	4 sec	46
leak testing machines	operator dependent	28
Yearly Assy Scrap Expense		~ \$135,000
Assembly WIP		variable (~1800)
Assembly Throughput Time		variable (~1 day)

2 System Level Change: Where does one start?

2.1 A Process Plan for Production System Design

There are numerous challenges to designing an entire manufacturing system stemming from the scale of the project and the interdependencies of several design aspects. In an attempt to make explicit the interdependent relations of the design and show the proper context of lower level design aspects (tools), Cochran and PSD have constructed the Manufacturing System Design Decomposition (MSDD) [22]. Resulting from this work, Cochran prescribes the following steps as those an organization should take when moving toward a lean system design [9]:

- Step 0. Determine who the customers are
- Step 1. Define linked cell system
- Step 2. Form cells based on takt time
- Step 3. Reduce setup times - Single minute changeovers
- Step 4. Improve quality and output predictability
- Step 5. Level manufacturing in assembly cells
- Step 6. Link cells with a pull system
- Step 7. Link suppliers with plant pull system
- Step 8. Integrate product development

While the steps in this list present a logical way to proceed, it may be argued that the list is not exhaustive. For instance, in the case of Coclisa a great deal of skepticism surrounded the project, and thus there existed a need to prove the benefits of cells before proceeding with steps 1

through 8. Thus, the manufacturing system design process started with Step –1: Demonstrate cell feasibility.

There are several reasons for wanting to start the design process with the design and implementation of a cell, but the most important stem from a need to instill confidence by reducing the number of uncertainties/unknowns and to demonstrate feasibility. The aspects of feasibility being demonstrated include the following:

1. current direct labor is capable of adapting to cells
2. the specific product is capable of being manufacture within a cell
3. current equipment can be modified to be cell compatible
4. investment needed to implementing a cell is reasonable and easily justifiable when compared to cost savings

Therefore, the “demo” cells that result from the attempt to demonstrate feasibility should be looked upon as a teaching tool since a properly designed cell integrates many lean concepts. Demonstrating cell feasibility is an important step to take before all others, whether faced with skepticism or not, and offer two benefits. First, the process of designing and implementing a cell forces the evaluation of the product and manufacturing processes used to produce it, with the concepts of a new sub-system in mind. In the case of Coclisa, the new sub-system meant replacing the assembly lines and machining departments with cells. A second, and more important, reason for wanting to pursue the feasibility of cells as a first step is that the generic structure of the “demo” cells can serve as the base model for all future cells in the system design.

A second deviation from Cochran’s list of steps came in Step 0, “Determine who the customers are.” Identifying the customers gives a basis for product family formation. The rationale for forming families in this manner is that if all products going to a single customer

constitute a family, then the system shown in Figure 2.1 can be achieved. In this system the flow of parts and information is in its simplest form, and a system-level goal is achieved. However, in the case of Coclisa, more than one hose makes up a single automobile's air conditioning unit. Thus, hoses going to a single customer are not necessarily similar in material, geometry, and size, and hence undergo different manufacturing processing routes. Forming product families based on customers would have led to an increased level of complexity at the subsystem (cell) level of design. Instead, families were formed on the basis of processing using the following criteria:

1. Material make up (all steel, all aluminum or hybrid)
2. Number of crimps (0, 2, 4, 6 or 8)
3. Braze type (none, saddle, charge valve, P-nut, stem adaptor, or other.)
4. Hose diameter (5/16", 1/2", 5/8" or 3/4")

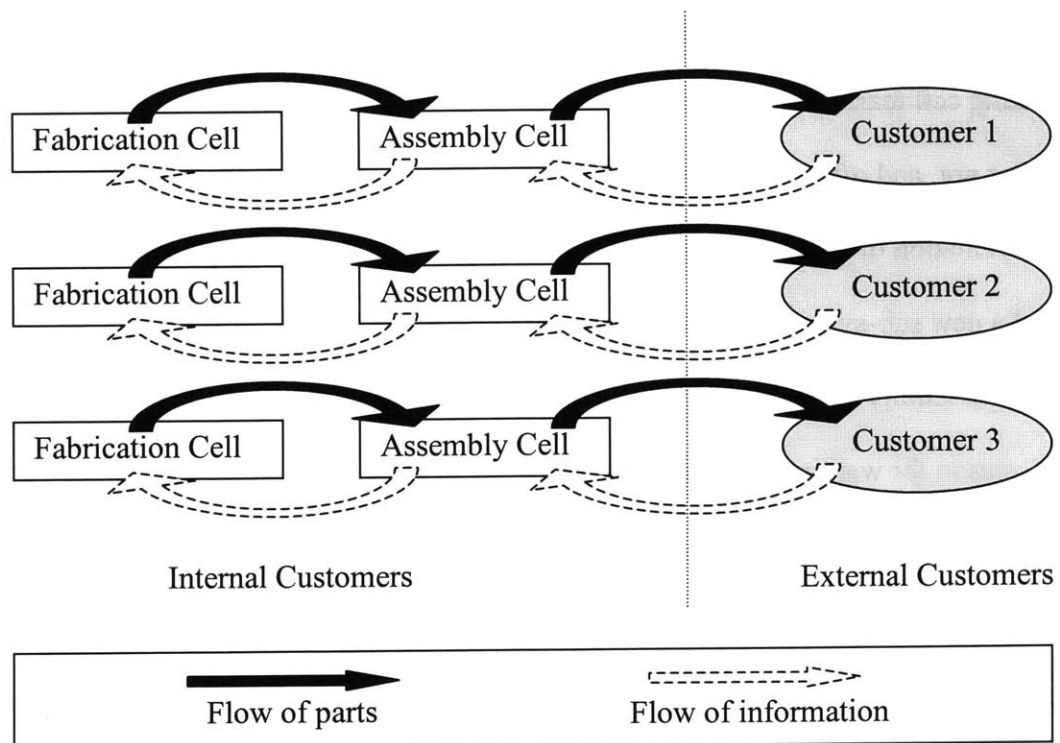

Figure 2.1: Product families based on customers for simplified flow [10]

2.2 Step -1: Demonstrate Cell Feasibility

Once the decision to demonstrate cell feasibility was made, three options for doing so were available. The first dealt with attempting to improve two cells Coclisa had installed prior to PSD's involvement. A second involved designing a single cell that integrated the fabrication and assembly for all low-volume products. The final option, and the one chosen, was to create cells for a high volume product by converting an entire assembly line.

2.2.1 Option 1 - "Fix" Existing Cells

Coclisa had formed two final assembly cells prior to the start of the system design project. While these first attempts at cell design were moderately successful in showing improvements over the assembly line, many fundamental cell design concepts were missed. Among the most common problems with these early designs was that the "cells" were perceived as being interchangeable with the assembly lines. This notion of interchangeability was most evident in the number of assembly line design concepts that crept into the design of these cells. For example, workers in these cells remained tied to a station, as they had on the line, and thus the ability to balance work was only marginally better (due to the longer cycle time) than it had been on the one-worker-per-station assembly line. Along with several other problems, these early attempts at cell design basically resulted "U-shaped assembly lines" that lacked important cell design concepts. Worst of all, and a clear indicator that the concepts of production system design were not well understood at Coclisa, the formation of cells, alone, was viewed as the end of a particular product's conversion to lean. A complete manufacturing system design was not the goal at the time these "cells" were implemented. Given that these "U-shaped assembly lines", and all their shortcomings, were equated with "lean manufacturing," questions regarding the appropriateness of a cellular approach to hose manufacturing began to arise at all levels of

the organization. Thus, one opportunity for demonstrating cell feasibility was to improve several aspects of these existing cells.

Working to improve these cells would have shown that the existing problems were caused by errors in design based on a limited understanding of various production system design principles. However, the option was decided against for two main reasons. First, when products were selected for these first cells designs, low volume, mainstream products were chosen. In this way, the consequences of failing to implement the cells would be less severe, since running the product on the line remained a possibility. Low volume products were also chosen to allow for a slow learning curve. Consequently, the design and installation of these cells was never considered urgent and once implemented, there was little attention given to evaluation, analysis, and the pursuit of improvements.

Knowing the products being run in these cells were not viewed as highly important, any improvements made would have a limited impact. Thus, the second reason for not opting to fix the existing cells was a concern that working to improve their current state may have involved more effort than simply starting anew. Another concern centered on the issue of the current cell design negatively influencing or hindering the level of improvement that could be made. For if the “demo” cells were to be used as a base model, the design of future cells would have also been affected.

2.2.2 Option 2 – Cell in Prototype Shop

A second option involved the design of a single cell capable of producing all low volume products, approximately 30 in total, that were currently being run in the prototype shop. The prototype shop was not part of the regular production system, and served two separate functions. As the name suggests, the shop provides the product engineering group with prototypes required

throughout the design phase of new products. More important to the production system, the prototype shop is expected to produce all low volume (typically less than 50 pieces daily) products that would otherwise be difficult to schedule and run on the assembly lines. Thus, it functions much like a job shop in which a few pieces of general equipment produce a wide variety of end products. A layout of the prototype shop is shown in Figure 2.2.

The plan was to create a single cell integrating fabrication and assembly, such that raw material came into the cell and a complete end product left it. Adding another level of complexity to the cell’s design was the fact that hoses for both production and prototyping were expected to run in the same cell. The issue was that the prototype parts did not have a standard processing route and each process required several attempts before the machine was properly setup. A cell cannot function under such conditions because it depends on standardized processing and reliable machine setup to deliver the benefits associated with it. The design of the cell for the prototype shop was not chosen for three main reasons.

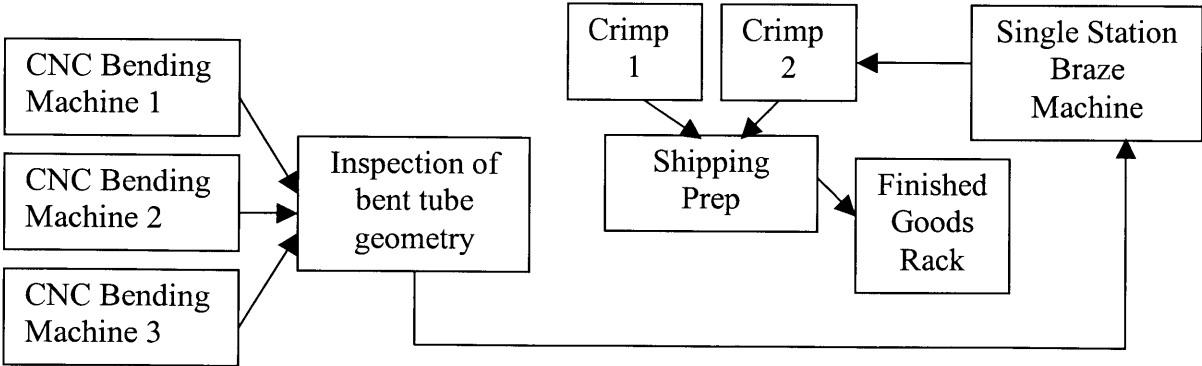

Figure 2.2: Layout of prototype shop with part flow

First, the logic for running all low volume products in a single cell was flawed. The thought was that products of a similar takt time should run together, where

$$\text{Takt Time} = \frac{\text{Available working hours per day}}{\text{Average daily demand}}, \text{ with units of } \left[\frac{\text{time}}{\text{part}} \right]$$

The misuse of takt time stems from the fact that it was being used as a basis for forming product families. The low volume products were chosen to run in a single cell based on the logic that products with similar demand have similar takt times, and should therefore be run together. When used correctly, takt time is calculated after product families are formed, and the denominator “average daily demand” is the aggregate demand of all products planned to run in a single cell. This faulty method for grouping products also added to the complexity of the cell, as there were major variations among the thirty models it was expected to run. Therefore, while it is true that properly designed cells should be able to handle product flexibility, this design goal should not be pursued at the expense of unnecessarily increasing cell complexity.

Another reason for deciding against this option, was that the cell was not going to run mainstream products, and thus it may have been a difficult to learn from this example. Moreover, with the prototype shop being detached from the regular production area, the cell would have received very limited exposure, again limiting the impact this cell could have had on Coclisa as a whole. The low volume cell would also have been difficult to learn from because the part flow in the prototype shop is different from that in regular production. The difference in product flow arises from the CNC benders used in the prototype shop since these machines cannot bend tubes with formed ends (see Figure 2.2).

However, the main reason for deciding against the low volume cell is that it had so many details and constraints that it would have been nearly, if not, impossible to design. This overly complex cell would confirm the doubts of lean’s critics: 1) hoses cannot be manufactured in cells or 2) given the amount of effort and expertise required to make a single cell function, it is not

feasible to convert the entire manufacturing system. Wanting to avoid these false and negative conclusions, the design of this cell was not undertaken.

2.2.3 Option 3 - Conversion of an Assembly Line

The third option was to convert an assembly line that ran a single product, of minimal complexity, representing the largest volume hose being run at Coclisa. These product characteristics made it an appealing opportunity to demonstrate cell feasibility. The fact that assembly ran only one product greatly reduced the complexity of the cell design since changeovers were not a factor. Also, many of the fixtures used on the assembly line could be introduced into the cell with minimal modification. The hose being run on the assembly line was the simplest type of hose being manufactured since it was all aluminum, required only 2 crimps, and had no brazes. These product attributes translated into a cell that could be quickly designed and implemented. Lastly, the fact that the hose had a high daily volume, twice that of the next highest volume product, assured that the cells would be considered a top priority.

However, the importance of the product to Coclisa was a double-edged sword. For on one hand, the attention surrounding the product would speed the time to implement a cell and would have several employees willing to help in the design and implementation. While, on the other hand, there would be little time to experiment with the cell's design since it was expected to produce the total daily output immediately after being implemented. In any case, the process of converting this highly important assembly line into cells was the option chosen to demonstrate cell feasibility.

2.3 Conclusions

Although the initial reason for wanting to demonstrate cell feasibility prior to taking the steps prescribed by Cochran was to gain the confidence of Coclisa, it proved to be a valuable

step for two other reasons. First, in order to demonstrate cell feasibility the specifics of hose production were critically evaluated at an early stage. While the specifics would eventually arise in Cochran's second step, "Form cells based on takt time," it is best to gain such knowledge as early in the design process as possible. Second, the generic structure of these demo cells eventually served as the model upon which all future cells in the system design would be based. With these cells in place and capable of meeting full production, reasonable estimates regarding the design of other cells was possible.

Once a decision has been made to demonstrate cell feasibility as a first step, it is essential that the product or product family chosen have the following attributes:

- Be relatively simple as compared to other products – starting with a more complex product may increase the cell's complexity and make the learning of lean concepts difficult to grasp
- Be of high importance to the company – such that there is an urgency and interest about the design and implementation of the cell, and more support is received during and after implementation.
- Be representative of mainstream production – the lessons learned from this initial cell will be more easily diffused throughout the production system.

3 Converting from Moving Assembly Lines to Cells

3.1 Introduction

Many companies attempting to convert from a departmental, mass manufacturing system to a linked-cell manufacturing system quickly get lost in the exercise of physically implementing cells, while system-level goals such as leveling production and simplifying material and information flow are forgotten. Thus, it is essential to emphasize the fundamental design differences that make lean systems superior to traditional mass systems. It needs to be understood that cells are not a quick or one-time solution, but rather the outcome of a thorough understanding of the need to reduce throughput time by operating with single-piece flow.

The Coclisa project required that a moving assembly line -- typically associated with mass systems -- be converted to cells which serve as the building blocks of a linked-cell manufacturing system. Once the cells were implemented, the two subsystems were compared in terms of 1) design process, 2) quantifiable measures, and 3) non-quantifiable benefits. This chapter will show how the measures used for system comparison, quantifiable and non-quantifiable, take root in the design phase.

3.2 Moving Belt Assembly Lines

The use of moving belt assembly lines is a familiar sight in the final assembly areas of most mass production systems. It is also typical for the entire final assembly area, composed of several assembly lines, to be treated as a department within the larger manufacturing system, where parts enter the department in extremely large batches, are taken to entry points along various assembly lines, and then wait to be processed. Despite the fact that mass systems operate in a batch and queue fashion, it can be argued that their moving assembly lines promote single

piece flow (SPF) -- the primary reason for converting to cells -- and thus the question may arise as to whether a conversion to cells is necessary. In an attempt to answer the question of why cells should be pursued over moving belt assembly lines, it is necessary to describe the fundamental differences in the design process for both, and the benefits, quantifiable and non-quantifiable, associated with these differences.

3.3 The Product's Basics

A common thought among those who have either failed to convert their manufacturing system or are hesitant to change, is that some products are better suited for cells than others. It is important to emphasize that the product being to be run in the demo cells was not altered in any way to make it a better candidate for production in cells. The product is not overly simple, nor complicated, and has neither very few nor many processing steps. The product is the hose and tube assembly shown in Figure 3.1, which acts as a connector between components of an automotive air conditioning system. At either end of the product there are aluminum tubes, each with a different type of end joint. In final assembly, the tubes are joined to a flexible, rubber hose by a crimping process. Other assembly steps include attaching O-rings to the tubes, leak testing the assembly, and placing caps on the tube ends for protection during shipping.

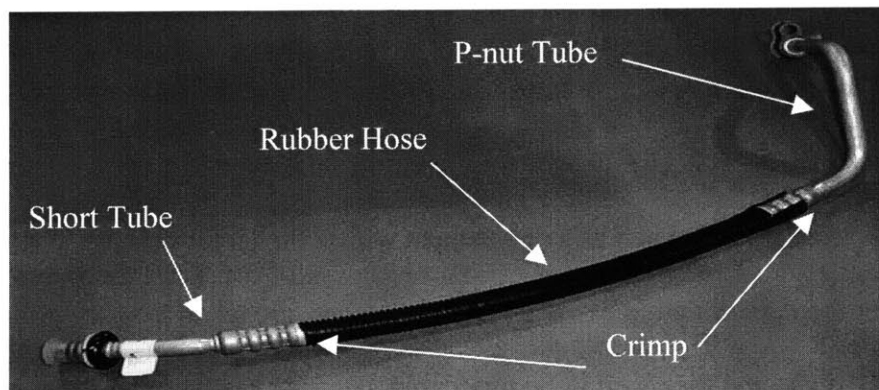

Figure 3.1: Connector between air conditioning components

The hose has an average daily demand of 4200 pieces, while 3600 and 4800 pieces are other quantities occasionally demanded. The production planning group always schedules these parts in multiples of 600 because it is the maximum number a shipping container can hold. Given the high demand, the assembly line and the cells that replaced it were both entirely dedicated to the final assembly of this single product.

3.4 State of the Assembly Line, June 1999

When the project began, the assembly line, had been running the hose for close to two years and was, by all accounts, mature in operation, meaning all the “bugs” had been worked out. The assembly line’s conveyor measured 90 ft. long and 3 ft. wide, while the entire working space of the line was about 100 ft. by 15 ft. The belt ran at a fixed rate of 470 pieces per hour, meaning that one part should come off the end every 7.7 seconds. In order for the product to be assembled at this high speed, 18 direct and 6 indirect workers were dedicated to the line. Figure 3.2 shows a layout of the line. These are the most essential variables that go into designing an assembly line. Thus, it is important to understand how these variables are related, and the sequence in which the design choices are made.

3.5 Simplified “Mass” Assembly Line Design Process

The following four steps, shown in the order in which they were pursued, are those taken in designing a mass assembly line

1. Determine the line cycle time
2. Determine a standard time for each operation by balancing the cycle time of each operation
3. Calculate the number of direct workers such that one worker will do each operation
4. Calculate the length of the belt

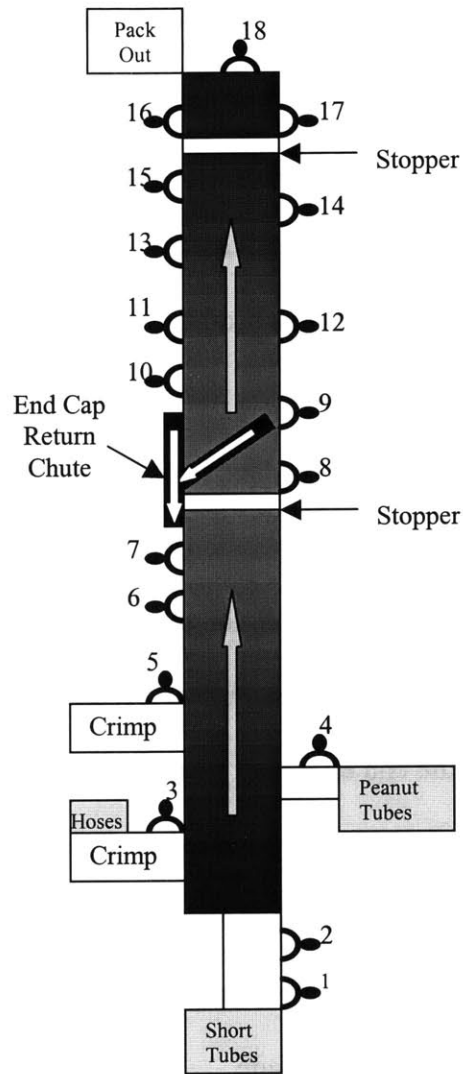

Figure 3.2: Layout of the assembly line

3.5.1 Determining Belt Rate

The company's work schedule philosophy dictated that the assembly line should complete hose production of the hose in the first shift. This design goal stems from the desire to have the assembly lines free in subsequent shifts to accommodate unforeseen spikes in demand and deal with problems that occurred over the course of the day, by working overtime.

As a result of the need to complete production in the first shift, which has 8.5 hours of available working time, a part needs to come off the line every 6.2 seconds (this result is

assuming an uptime factor of 85%). However, when the line was introduced it was rated for an output of 470 parts per hour or a finished part every 7.7 seconds. When volume later increased, the fixed belt rate led to a dependence on overtime of at least one hour a day to complete production. While one hour may not seem like a lot of time, it should be kept in mind that for the assembly line to function all 18 direct workers are needed. The yearly cost of overtime for all direct workers of this particular line is approximately \$4500.

3.5.2 Determining Operations' Standard Times

The operations that took place on the mass assembly line are shown in Table 3.1, along with their standard times. Standard times are the result of time studies conducted by the plant's Industrial Engineering Department. In some cases, a worker was much faster than the predetermined work standard, and in other cases the worker could not actually meet the target time. An example of the latter was observed in operation 11, attaching a sleeve over hose. The task took so long that a second operator was permanently added to the line to make sure that this operation did not disrupt the flow. These workers correspond to #11 and #12 in Figure 3.2. They sit across from each other, on either side of the moving conveyor belt, and each picks every other part that comes down the line.

Table 3.1: Final assembly work standard times

Op #	Tasks completed by operator	Std. Time (secs)	# of operators required
1	Remove shipping cap, inspect, attach metal spring to short tube	7.6	1
2	Attach 3 O-rings to short tube	2.2	1
3	Crimp short tube to hose	3.8	1
4	Remove shipping cap, inspect, attach O-ring to peanut tube	3.6	1
5	Crimp peanut tube to hose	4.7	1
6	Attach end cap to peanut tube	3.9	1
7	Attach end cap to short tube, and load assembly with helium	3.7	1
8	Leak Test	4.4	1
9	Unload helium and remove end cap from short tube	4.7	1
10	Remove end cap from peanut tube	2.8	1
11	Attach sleeve over hose	4.7	1
12	Attach indicator and shipping cap to short tube	4.3	1
13	Attach shipping cap to peanut tube	3.5	1
14	Attach product label	2.9	1
15	Final inspection	9.2	2
16	Package parts	1.9	1
	Total Processing Time	67.9	

3.5.3 Calculating the Number of Direct Workers

In calculating the number of direct workers for a mass assembly line, the only constraint pertains to the product's assembly sequence since some operations must precede others. With this constraint in mind, the next step is to group tasks so that the line is balanced, meaning that each operator has roughly the same work content, based on time, and that this time is less than the belt speed. The final step is determining the number of workers needed for each task by using the following equation:

$$\text{Number of Workers per Task} = \frac{\text{Standard Cycle Time of Task}}{\text{Line Cycle Time}}$$

In most instances each operator has a single task, but in the case of final inspection, which is greater than the belt speed, two workers were given an identical task. These tasks correspond to workers #16 and #17 in Figure 3.2.

The obvious problem with this method is that almost all the workers, by design, have a great deal of idle time per cycle. Figure 3.3, provides a plot of the work standard times against line cycle time, and shows that the workers are idle for 50% of a part’s throughput time. This loss of worker utilization is largely due to the fact that with a cycle time of 7.7 seconds, there are very few choices for combining operations.

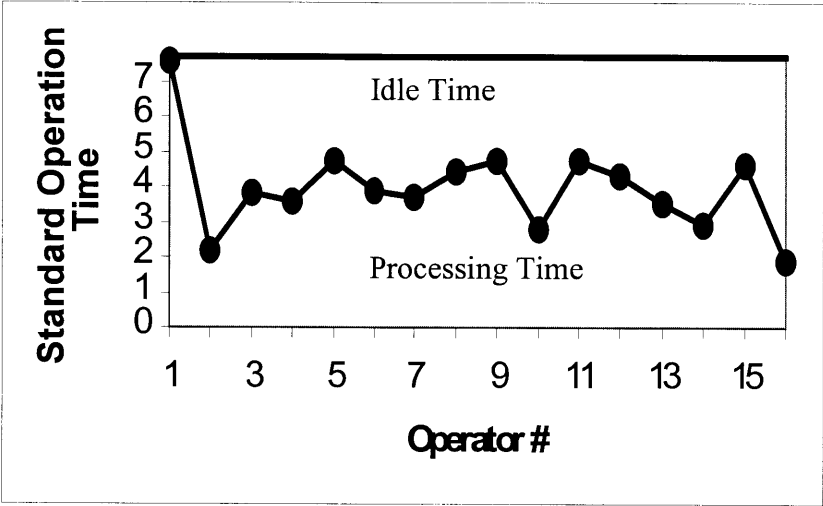

Figure 3.3: Workers are idle for half of the assembly line throughput time

3.5.4 Calculating Belt Length

Once the number of workers needed and their positions along the line are known, the last step in designing the moving assembly line is to determine the length of the belt. The length is determined by allowing sufficient space between workers so that they are able to keep up with the belt speed. Since the operations that actually take place on the belt, #3 through #15, all vary in time from 2.8 seconds to 4.7 seconds the spacing also varies to smooth out these differences. The typical spacing between operations along the line is about 5 feet.

3.6 Discussion of Problems Observed on the Assembly Line

Prior to the conversion of the mass assembly line to cells several problems were observed, most of which caused the line to stop for varying amounts of time. Most of these problems are directly associated with the design of the moving assembly line.

3.6.1 Conveyors Create the Need for Final Inspection

The most serious problem with a conveyor belt assembly is that a part can pass through a station unprocessed. On the hose assembly line, physical stoppers on the line, before leak test and final inspection (see Figure 3.2), to ensure all parts are processed at these particular stations. However, putting a stopper in front of each station is unfeasible, and so a lengthy final inspection becomes the only solution. It becomes the task of the final inspectors to check the work of the 15 people before them. Because the inspectors also have to respect the fast line cycle time they are rushed to complete the inspection, and defective parts pass through on a regular basis.

Another inherent problem with the use of a conveyor for assembly is that it is linear, and so the inspectors' effectiveness is minimized. When the final inspector finds a defect there is nothing he can do except pull the part off the line. For example, when an inspector notices that Operator #2 only put two O-rings on the product instead of three, he may be inclined to quickly fix the part by attaching the O-ring himself, but cannot disrupt his work by walking 90 feet to do so. As a result, the defective parts are placed in a rework area. It may be hours or even days before the defective parts receive attention. Therefore, the output quality of a particular product type is highly variable and unpredictable, which leads to additional costs in scheduling overtime, floor space, and premium freight. In our example, where the entire assembly is only missing one O-ring, the person reworking will have to relocate the defect, and if he misses it, may send the defective part through for packing.

3.6.2 Lines are Never Truly Balanced

A result of trying to balance operator time to a fast belt rate is that some operators end up with very little work content per part as shown in Table 3.1. In reality, people who are stationed at material entry points are not dependent on parts coming down the line, and quickly reason that they can work ahead of the belt, building up work-in-process (WIP). By doing so, workers essentially create for themselves additional break time. Problems arise because the workers building WIP typically choose to send it down the line in small batches, and then feel free to leave the area. Meanwhile, the next operator is left with no choice but to pick the pile of WIP from the line and clutter his working area, a major inconvenience. However, the larger problem is that the fast operator may not return to his station prior to the WIP running out, and as a result the entire line will stop. With a quarter of the workers able to build up WIP, it is a conservative estimate that at any time there are at least 150 pieces of WIP on the line, roughly 60% more than expected by design. Consequently, the assembly line's throughput time may be as high as 20 minutes, while the belt speed times the number of workers suggest that the throughput time should be about 2 minutes.

The other issue with workers operating at several different cycle times is that the method of material replenishment, in which the material handler simply walks the area waiting to be asked for parts, often results in material shortages. The length of the belt plays a role in the material handler's job since it is not uncommon for him to be far from the station needing material. To make matters worse, there are no standard replenishment quantities to give the material handler a better feel for when to replenish. Rather the empty bins are simply filled with as many parts as possible, and the quantities vary greatly.

3.6.3 Loss of Predictability

WIP and material replenishment problems are two of the problems that make the output of the assembly line unpredictable. Once predictability is lost, the job of the supervisor becomes difficult since he must evaluate production hourly and if it is not on target, he must figure out what to do. He will probably not get to the root of the problem, and instead spends his time on quick fixes, usually finding volunteers to stay overtime.

3.6.4 Intentional Line Stoppages

One “lean” concept that has crept into the design of assembly lines is the idea that all workers are free to pull a stop cord if there is a problem. While this concept works well within a properly designed cellular system, it has few benefits on a line since the workers are isolated and thus do not attempt to understand and solve the problem that created the line to stop. When the line is stopped, several reactions take place among the line operators. Some automatically reach for their newspapers, others leave, and those in the habit of building WIP continue producing in order to gain an even longer break. These various reactions point to the fact that the 18 direct workers on the line do not feel that they are part of a team. Instead each worker is conditioned to only feel responsible for the operations that take place at his station, and if the problem is not due to him, then he is indifferent because the design of the assembly promotes it. The end result is that no one is aware of the reason why the line stopped, and how the problem was solved. Thus, the chances of there being another line stoppage, are higher than if a team worked together to solve the problem.

3.6.5 Lack of Flexibility

With the hose assembly line at Coclisa demand increased beyond the belt rate originally designed for, and the only solution was to work overtime everyday. Had demand decreased, the line is still designed for a fixed belt rate, and each day production would have been completed

early. Thus, the 18 workers would have no work for the remainder of the shift. It is important to reiterate that, by design, the assembly line requires that all 18 workers be present in order to function. Thus, the problem of absenteeism, not looked upon favorably in any system design, is an especially large problem in the case of the one-person-per-station design of mass assembly lines.

3.6.6 No Concept of Continuous Improvement

While several of the above problems are immediately evident, the fact that they persist can be attributed to the lack of continuous improvement efforts. While many fire-fighting efforts are put forth on behalf of the assembly line, the results should not be confused with continuous improvement. Instead, continuous improvement emphasizes the fact that there are always better ways to operate the current system, and that a manufacturing system must be designed in a way that it can be improved. Thus, several systems aspects are regularly analyzed and challenged in search of improved methods. In the case of the hose assembly line, where basic variables such as belt speed and operator times are “standard” implies that these are not variables subject to analysis, little room is left for true continuous improvement.

3.7 Goals for the Conversion to Cells

Upon taking on the assignment to convert the line to cells, three goals were agreed upon:

1. the equipment to be used in the cells could only come from that being used on the line
(no additional equipment could be purchased)
2. once implemented, the cells were responsible for producing the required daily volume
(the cells were not being built for experimental purposes)
3. the cells were to serve as a teaching tool for all employees.

3.8 Simplified Cell Design Process

In a lecture entitled “Cell Design” [8], Cochran identifies the following steps as those needed to design cells within a lean system.

1. Define part families.
2. Determine takt time.
3. Standardize process and operator routine.
4. Is the takt time met? If not, is it due to operator delay or machine delay?

3.8.1 Defining Part Families

In this initial conversion to cells only one hose type was considered because of its high volume, and therefore defining part families was not relevant at this point.

3.8.2 Determining Takt Time

By definition, takt time is the total available working hours in a day divided by the customer’s daily demand (see equation in section 2.2.2). The value arrived at is in units of time and tells the manufacturer how often a customer needs a part and thus how often to produce. While takt time calculation is similar to determining belt rate, it is a more integral part of the cell design since a primary design goal of an overall lean system is to match production pace with customer demand.

Moreover, in lean thinking, both the denominator and numerator in takt time calculation are viewed as variable. With takt time perceived as dynamic, a fundamental difference in the approach to cell design is that volume flexibility is emphasized from the onset. For this reason, an underlying design goal is that the cell be capable of running with a single person, should the need arise. This goal greatly affects machine and workstation design.

Due to the equipment constraint, a maximum of two cells could be formed. The different takt time calculations that were considered are given in Table 3.2, with the available working hours per day being the only variable. The calculations are based on the following:

1. 8.5 hours of available working time in the first shift
2. 7.5 hours of available working hours in the second shift
3. an uptime factor of 85%
4. a daily demand of 4200 pieces.

Table 3.2: Takt Time Calculations

Work Schedule	Takt Time (sec)
a) 1cell, 1 shift (same as line)	6.2
b) 2 cells, 1 shift	12.4
c) 2 cells, 2 shifts	23.3

In order to achieve the full benefits of a cell, takt times should be greater than 30. While running two cells for two shifts gives the highest possible takt time, ideally a third cell would have been formed. In this way each cell would have had a takt time of 35 seconds. Deciding to run a second shift was a major departure from the company's traditional operating pattern.

The pursuit of two cells meant that each cell would have one crimp machine, and that the cells would share the leak tester, as shown in Figure 3.4. The dotted line is intended to show the separation of the two cells. The cells' U-shape is a function of the cells needing to share the leak test equipment (shown as the dot in the crosshatched section). The sharing of the leak tester is not ideal, since it makes the cells interdependent, in that the two cells have to coordinate so that the person testing in one cell is not waiting for his counterpart in the other cell to finish using the equipment. This coordination adds a level of complexity that would have been better avoided, had there not been an equipment constraint of using only one leak tester.

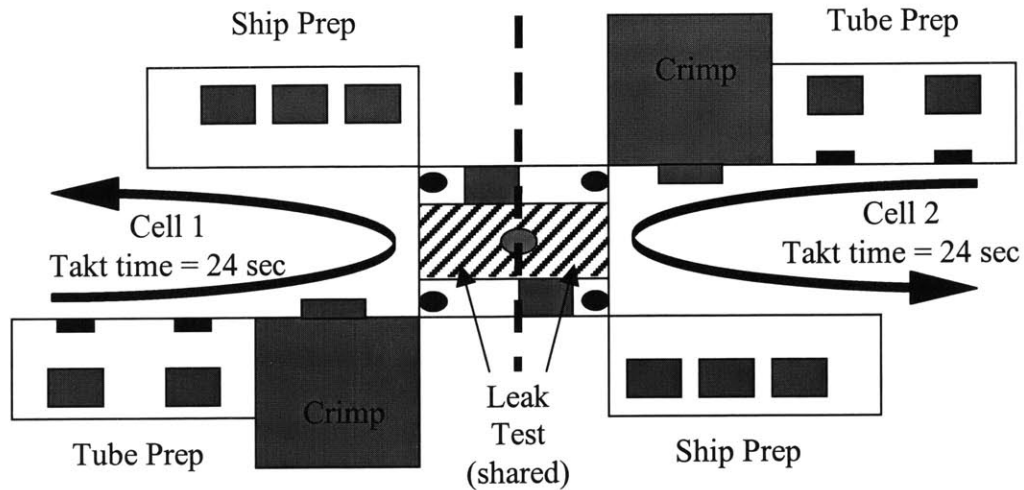

Figure 3.4: Layout of the two cells used to replace Line 4

On the assembly line, each of the two crimp machines was dedicated to crimping only one end. In order to place a single crimp machine in each cell, another shift from traditional operation was made in that each machine would now have to crimp both ends of the product. The change required the design of new fixtures capable of holding the product while each end was crimped individually.

3.8.3 Standardize Process and Operator Routine

Another fundamental difference between the design of assembly lines and cells is the consideration given to the order of operations. When designing cells, the product's assembly sequence must only be respected in terms of the cell's physical layout. However, the fact that the workers are walking and multi-functional means that their workloops do not necessarily need to follow the product's assembly sequence. For instance, a worker may be given tasks 1, 2, and 3 and then jump to tasks 15 and 16 in his loop. This added flexibility in forming workloops, along with the higher takt time, provides several choices for combining operations when defining standard loops. The workloops are always subject to improvement, and thus the term standard

means that an agreed upon loop will be strictly adhered to, until such time that the improvement is implemented. The only constraint in designing workloops is to have the sum of each worker's operations, plus walking time, be less than the takt time.

Through analysis of the hose's assembly operations, it was found that the tasks all fit into one of three main categories -- assembly, leak test or shipping prep as shown in Figure 3.5. Figure 3.5 shows that while it is necessary that shipping prep follow leak test, and that leak test follow assembly, within each of the three categories the order of operations is not significant. For example, O-rings can be attached before or after crimping, and either tube can be crimped to the hose first. This realization offers yet another level of freedom in determining workloops, and allows for a great deal of iterations to be easily tested during the implementation phase of the cells.

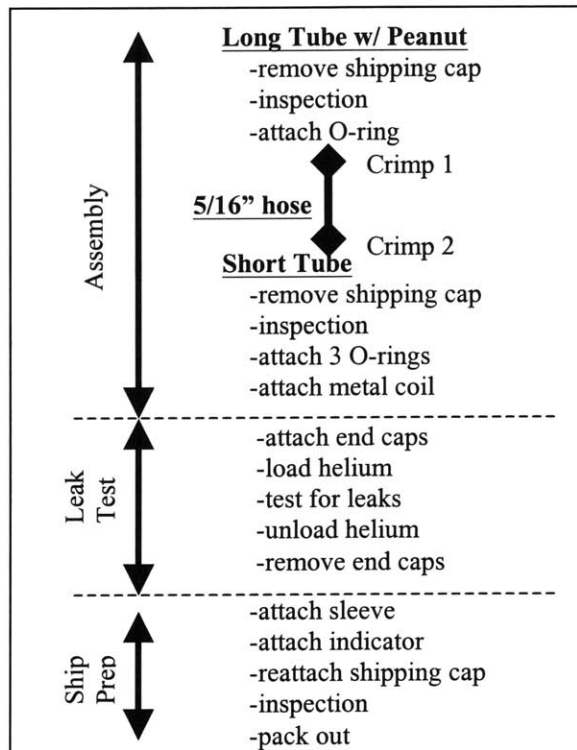

Figure 3.5: Breakdown of final assembly operations

The number of workers needed to run the cell was decided by dividing the sum of operating time as determined from assembly line standards (67.9 seconds) by the takt time. The logic is that the time assembly line operators spent reaching for a part and returning it to the line would totally cancel the minimal walking time within the cell (the operators' travel distance is less than 10 ft.). In any case, this first pass calculation suggested that three workers would be needed, and that each should be given about 23 seconds of work to do in a loop. After several theoretical iterations it was decided that in terms of balancing the workload and minimizing the amount of non-active walking time it would be best to have

- the first worker prepare both tubes and make the first crimp,
- the second worker make the second crimp and leak test,
- the third worker remove the end caps and prepare the part for shipping.

3.8.4 Cell Testing: Is the Takt Time Met?

In the first rounds of testing, the new cell design was not meeting takt time. The sum of manual and walking times was close to 85 seconds, which is above the desired cell throughput time of 72 seconds in which each worker had 24 seconds to complete their respective tasks. Given that the machinery in the cells had a processing time well below the takt time, it was easy to conclude that the problem lay with the operators.

Upon further examination of the situation, it was realized that once the operators were asked to do tasks they were unfamiliar with, a learning curve was to be expected. What is more, once the workers were asked not only to do a larger set of operations per workloop, but also be responsible for knowing all the operations, it was to be expected that they would not necessarily master any one task, but rather become efficient at completing their workloops.

Thus, the conclusion was that the three cell workers simply needed time to familiarize themselves with the new system, and adding a fourth worker to the cell was decided against. The three workers were made fully aware that as a team they were responsible for producing a finished part every 24 seconds, and then asked what could be done to help them accomplish this end. The resulting communication led to the workers becoming involved in improving their workloops, the different workstations, and identifying processing steps they felt were not essential.

Within only a few days of all the changes being implemented, the workers were very close to producing a part every 24 seconds. An unforeseen advantage of having two identical cells placed back to back is that as the workers spoke to each other, the best practices of each cell were being adopted in both. As a result, the cells matured very quickly. Therefore, after a month of running the cells it was not surprising to find that their cycle times were down to about 20 seconds.

Since the time being saved was not enough to justify the removal of a worker from each cell, a material handler was introduced to pace the cells. Keep in mind that while the system should meet customer demand, overproduction is not desirable. A single material handler replenishes both cells by working on a 10 minute cycle. However, since he alternates between the cells, he provides each with 20 minutes worth of parts (50 parts). The introduction of a material handler now meant that there was feedback every 20 minutes. This was made possible by having the material handler count how many parts, if any, were left in the bins when he returned after 20 minutes. This tally along with an explanation as to why production was not met during a certain interval, now gave the supervisor a much clearer picture as to where his problem solving efforts should be directed. For example, it was found that in the interval before lunch,

production was not being met because one worker was leaving a few minutes early. While the problem was relatively minor and easy to solve, it would most likely have gone unnoticed on the line.

3.9 Comparison of Quantifiable Measures

As stated earlier, cellular systems tend to consistently outperform mass systems on several quantifiable fronts. In a comparison of the assembly line to the cells that replaced it, the results are no different. Table 3.3 shows that comparison. The most striking results are in the 78% floor space savings, and the 45% reduction in man-hours required for production.

Table 3.3: Comparison of Assembly Line 4 to Cells

Measurable	Assembly Line 4	2 Cells
Floor Space	1500 sq. ft.	320 sq. ft.
Direct Workers	18	12 (3 per cell for 2 shifts)
Cycle Time	6.2 sec	24 sec
Man-hours required	~170	96
Avg # of Defects per Month	226	2.5
% Absenteeism	4	0
Throughput time	Variable (~20 min)	72 secs
WIP	Variable (~150)	6 (3 per cell)
Incoming Material	High and variable	50 pieces/20 min
Conveyor	90 ft	none

3.10 Discussion of Non-Quantifiable Benefits Obtained Through Cells

3.10.1 Ability to Balance Work Content

As shown earlier, balancing work on the assembly line is difficult for two reasons. First, the line is designed such that workers are tied to a single station, and thus the work done at each station must follow exactly the product's assembly sequence. Consequently, this one worker, one station design reduces the ability to give an operator work content that is closer to the line cycle time. The fast line cycle time itself is another issue in balancing since it further reduce the number of tasks a worker can be assigned.

In the case of cells, takt times of 30 seconds are usually sought, and at these slower cycle times a single operator to take on several tasks per cycle. Also, by having the worker walk and be multi-functional, rather than tied to a station, several combinations are possible when defining the workloop. As a result, the workers are more effectively utilized. Moreover, by each worker having a better understanding of all the tasks involved to assemble the product, making suggestions and solving problems becomes easier.

3.10.2 Workers' Attitude

Among the most important benefits of cells is an improved attitude of the workers toward their jobs. Once the workers were trained to be multi-functional, two things happened. First, their level of interest in the work itself increased. This increase in interest was evident in the fact that on assembly lines it is common for people to wait for instruction before doing anything out of the ordinary (such as during line stops), while the cell workers tended to be more confident at solving problems on their own. Secondly, the cell workers were more inclined to give opinions and constructive criticism of the cell. Such discussion was often fruitful, and leads to the workers giving thought to their jobs and constantly seeking improvement.

It is of utmost importance that all ideas put forth by cell workers be taken seriously because the workers' major source of reward comes from seeing their ideas take form. If workers are content, and play a role in designing their work space, the benefits are endless. The closest gauge of the workers feeling of importance and reward comes from the sharp drop in absenteeism that was experienced when the assembly line was converted to cells.

3.10.3 Volume Flexibility

The most often discussed benefit of cells, which is difficult to quantify, is volume flexibility. Cells are designed such that workers can be added or removed in order to match

customer demand, while the number of workers on an assembly line is fixed. Along the same lines, absenteeism is not as great an issue with cells as it is on assembly lines, for even if only one cell worker is present he can still deliver some level of production. This is a significant improvement over line production where if even one worker is absent, no production is possible.

3.10.4 Predictable Output Exposes Problems

An important problem exposed by the final assembly cells producing at a predictable output is that several of the components being fed by upstream processes are defective. With the material handler delivering only 50 parts every 20 minutes, defects prevent production from being met for that interval, and cannot be tolerated. On the assembly line where parts arrive in large batches, at varying time intervals, quality problems with the incoming material are hidden.

3.11 Conclusions

A cell is a physical tool that integrates several system and subsystem-level objectives. A cell is designed in line with the manufacturing system design, it becomes a tool for achieving the system-level goals, as this chapter has illustrated. The thought process behind cell design varies greatly from that used to design an assembly line. Moreover, while the primary goal of the assembly line is to reduce labor cost through high speed production, the primary goal of cells is to allow for single-piece flow such that throughput time is decreased and leveling production to match customer demand is possible. These major differences lead to several quantifiable and non-quantifiable advantages of one system over the other, as highlighted in Table 3.4.

Table 3.4 General Comparison of High Speed Lines and Cells

	High Speed Line	Cell
Balancing	Difficult. One worker per station assumption and the fast line cycle time. As a result workers spend a great deal of time idle	Easy. Several combinations possible since workers are walking and multi-functional. These attributes allows them to work independent of the product's assembly sequence
Workers	Underutilized and often unable to take action in problem situations	Effectively utilized and in a position to take initiative to resolve problems
Ability to Correct Defects	The physical arrangement isolates workers and does not allow workers to correct easy-to-fix defects	Circular workloops with all workers inside the cell encourages teamwork and facilitates the correction of defects
Ability to Improve	Limited. Operations and the associated standard times are considered fixed	Continuous. Workers continually suggest improvements and all processing time are considered variable
Defects	High and root cause for defect seldom found since incoming batches allow operators to continue working despite quality problems	Low since defects cannot be tolerated and thus are quality problems are quickly addressed. Feedback from material handler enables fastfeedback
Throughput Time	Variable due to workers building WIP	Constant and predictable since workloops are balanced and adhered to
Overtime	Necessary if volume demanded exceeds that which the belt is rated for	Can be avoided by the addition of a worker when volume demanded increase
Ability to Produce:		
Right Mix	Not feasible since the task of changing over the line is time consuming	Cells should be designed for quick and easy changeover which accommodates the production of different models in a single cell
Right Quantity	Not possible. Line designed to run at a single fixed speed. Assuming no problems will occur, at best a maximum production volume can be calculated ahead of time	Possible by the addition and removal of workers to the cell as needed to meet customer demand rate.

4 Product Family Formation

4.1 Introduction

At Coclisa, the success of the demo cells led to an assumption that the best way to proceed with the remainder of final assembly conversion was to replace each assembly line, one by one, with cells. The company felt this approach would be most logical, citing the ease of transition of Assembly Line 4 to cells, where the line supervisor became the cell supervisor and workers were the same as those who had worked on the line. The point being missed, however, is that this approach was only suitable in the case of Assembly Line 4 because it was dedicated to producing a single product. On all other lines multiple products are run, and it is necessary to assess whether the products currently run on each line constitute a family that fits the system-level goals. Where products do not constitute a family, cells formed to duplicate the production of a particular line will be more complex.

Seeing the success of the assembly cells, the quality and fabrication departments wanted to rush ahead, and begin forming cells so that they could share in the benefits being realized in the assembly department. Thus, while there was a high level of enthusiasm to convert the entire manufacturing system, if misguided, this same enthusiasm may lead to disaster. For if all departments were to form cells independent of one another, the result would be a scatter of cells throughout the manufacturing system, all based on different logic without the value stream or customer in mind. Just as the individual cells, described above, will be more complex, the same is true of the manufacturing system made up of such cells.

Therefore, after demonstrating cell feasibility it was necessary to delay the formation of more cells, until a complete plan for conversion was in place. Taking the first step toward

generating the plan, and the next step in the overall system design process, meant answering the following questions:

- What products will run together in each of the cells to be implemented?
- In what order will the cells be implemented?
- What is the basis for prioritizing?

The answers to these questions rely on the basis chosen to form product families. The formation of product families is crucial to the success of the final design since it dictates the complexity of the system, and provides the macro-level strategy to be used during the conversion process. In the case of Coclisa, equipment constraints and the formation of product families, pointed to a strategy calling for the complete conversion of the final assembly lines to cells, followed by the conversion of the fabrication area, and lastly, the linking of cells by a material handler.

4.2 The Importance of Product Families

The criteria by which product families are formed dictates the complexity of all three levels of the manufacturing system design -- system, cell, and machine. Thus, when deciding which products constitute a family, the goal is to simplify design at all levels. At the system level, the greatest impact of product family formation is on physical layout as this determines the material and information flow. At the cell level, product families dictate the complexity of the fixture design, the amount of changeover required, and the “intuitiveness” of the cell -- how easy it is for the cell operators to learn their job and make suggestions for improvement. The manner in which product families are formed also dictates the number and complexity of individual machines within a cell.

4.3 What products will run together in a single cell?

Coclisa manufactures 85 different hose models, with any one model possibly having multiple final customers. Moreover, a vehicle requires more than a single hose to build up the climate control system. A distinct vehicle type requires four very different hose models shown in Table 4.1.

Table 4.1: Comparison of Hose for Single Vehicle

	Material	Number of Crimps	Hose Diameter 1	Hose Diameter 2	Total Number of Bends
Hose 1	Hybrid	2	13/32	N/A	7
Hose 2	Hybrid	4	13/32	5/8	13
Hose 3	Steel	0	N/A	N/A	5
Hose 4	Steel	2	5/8	N/A	6

Assume that there are three final customers demanding each of these hoses, and that each customer orders enough parts to justify having a dedicated cell. In this case, there are two options for forming product families. One based on the final customer, and the other on processing requirements. In this example, where multiple customers have identical orders with regard to product types, but the desired products are all different, forming cells strictly on the basis of the final customer will lead to the following problems which will be highlighted in the next section:

1. the unnecessary duplication of similar cells, and
2. individual cells having to run hose models with very different processing routes and specifications.

4.4 Customer Based Product Families

In the above example, if cells were formed based on the final customer, the result would be three identical cells running in parallel (similar to the configuration shown in Figure 2.1), with each cell potentially having a different takt time since each final assembler produces a different

quantity of vehicles. While there is no problem with the duplication of cells in the event of a volume increase, issues arise when the cell being duplicated is overly complex and its equipment is not being used effectively, as would be the case with these assembly cells. To explain how customer-based families would lead to the above problems, the logic for the design of assembly cells in this scenario is presented in detail.

In the hose assembly cells, the only pieces of equipment utilized are the leak tester and the crimp machines. In the case of crimp machines, the following two assumptions are made regarding their use:

1. a crimp machine can make at least two crimps of the same diameter, and
2. a crimp machine can crimp either aluminum or steel.

The number of crimps that can be made on a single machine depends on two variables. First is the fixture design. As was the case with the demo cells, it was possible to crimp both ends of the hose on a single machine. The second variable is the diameter of the hose being crimped, since crimping dies are specific to hose diameter, and the dies must be changed over.

In the second assumption, each machine is currently capable of crimping both aluminum and steel without making any parameter changes. Adjustment is avoided by having all machines set to crimp steel, which requires more pressure, and by having the stationary crimping die act as a stopper when crimping aluminum. See Figure 4.1. However, the desired final diameters are different for aluminum and steel, and thus the crimping dies for hoses of the same diameter are different. Aluminum tubes are crimped to a smaller diameter than steel tubes because both must be capable of meeting the same standard when subjected to a tension test. The standard is set so that the hose in tension must tear, rather than slip out of the crimp. Thus, in order to avoid changing the crimping fixtures when running different materials of the same diameter, the

assumption is that the diameter specs for steel and aluminum can be brought into a range that is acceptable for both.

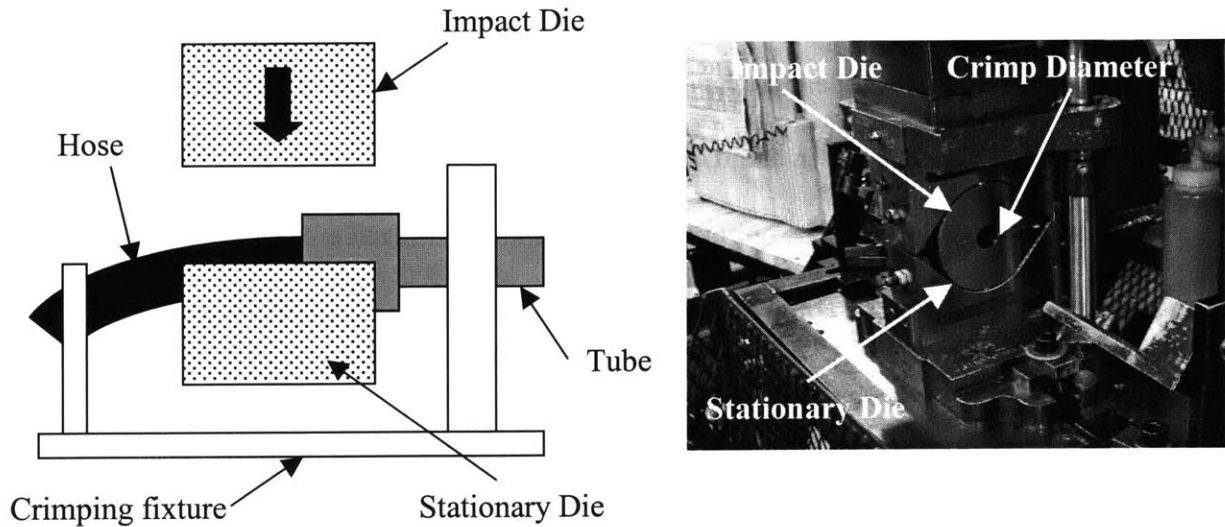

Figure 4.1: (left) Front view of crimping machine setup with dies in the open position. (right) Side view of dies in the closed position.

If both assumptions hold true, each of the three cells would require a minimum of two crimp machines in order to assemble the hybrid, four-crimp model (hose 2 in Table 4.1). One machine would make both $13/32$ " crimps, while the other would be set to make the other two crimps at the $5/8$ " diameter. Figure 4.2 shows a typical hybrid, four crimp model, in which the product design calls for the hose diameter between components to be different. The tubes shown in black and the junction where they meet, referred to as a manifold block, are made of steel, while the gray tubes are aluminum. The reason the model uses both steel and aluminum is that the manifold blocks are yet to be made of aluminum. Thus, tubes brazed to it must continue to be made of steel as well.

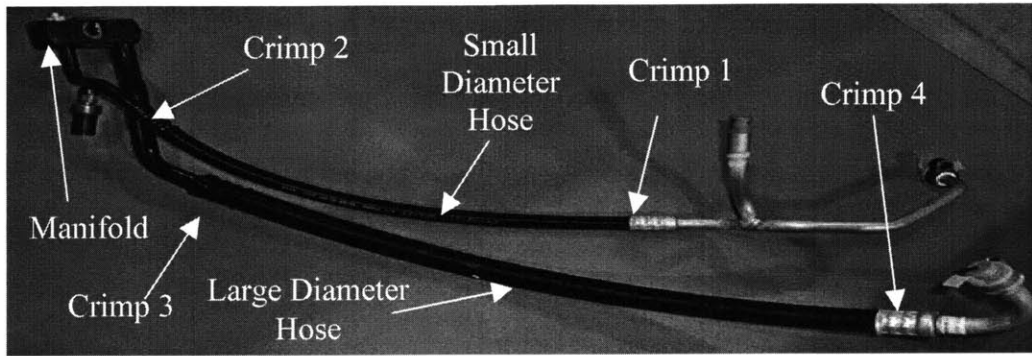

Figure 4.2: Typical hybrid, 4 crimp model, in which the design objective is to change hose diameter between components of the climate control system

If product families are based on the final customer, then each of the three cells requires two crimp machines, and as shown in Figure 4.3, each machine would only be used half the time. The 5/8" crimp machine is only used to process hoses 2 and 4, while the 13/32" crimp machine processes hoses 1 and 2. Thus, to run hose 2, which is only 25% of the volume, the inner length of the entire assembly cell needs to be increased by 3 feet (the width of one crimp machine). Thus, the cell occupies more floor space than necessary. It is important to note that while machine utilization is not the deciding factor in the formation of product families, in the case of Coclisa the current crimping machines were cell compatible, and thus an effort was made to effectively make use of this resource.

“Effective use” of a machine is a measure of how many of the products being processed in a cell make use of that machine. If all the products of a family go through a particular machine, then it is being used effectively. While the situation in which a machine is placed in a cell to accommodate only one of several models is considered the least effective use of the machine. Thus, the term *effective* is not to be confused with the concept of maximizing machine utilization in which the goal is to run a machine continually, and as fast as possible, in order to receive product at or near the machine’s full capacity.

In this simple example of the customer-based product family, a total of six crimp machines would be required, and each would only be used in half of the total cycles run in the cell. When extended over the entire range of hoses being produced at Coclisa, it is evident that forming cells on the basis of customer would require several crimping machines that would most likely be used ineffectively. While the effective use of crimping machines has been the focus of this example, several other piece of processing equipment such as the brazing machines are at risk of being used ineffectively if families are formed on the basis of customers, rather than processing sequence.

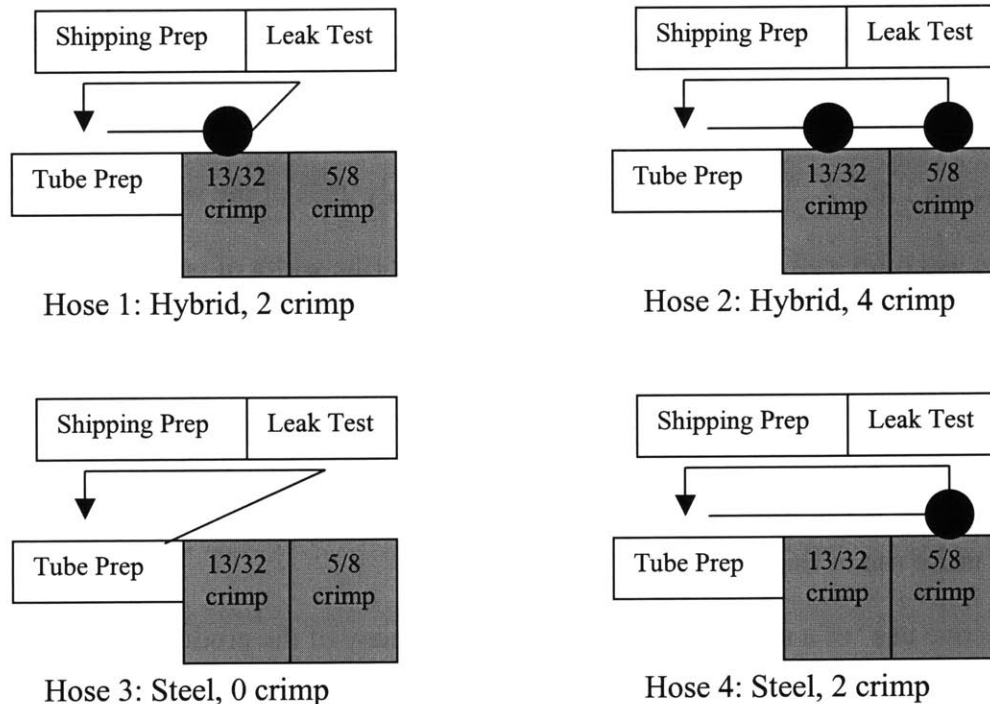

Figure 4.3: Different workloops used in a single assembly cell to produce the 4 hoses of the customer-based family. Black dot means the crimp machine is used in assembly of that hose.

4.5 Processing Based Product Families

4.5.1 Large Families

To avoid the problems of ineffectively utilizing equipment and unnecessarily complicating the design of individual cells, Coclisa products were grouped on the basis of the manufacturing

processing sequence within the factory. The first factor that determines the processing a tube will undergo is its material type, and thus, the end models were first grouped into one of three categories – aluminum, hybrid or steel. Next, to minimize the number of crimping machines used per assembly cell, within each material type, the end models were sorted by the number of crimps required, 0, 2, 4, or 6+. Classifying by this characteristic meant there would be no situations in which a cell would have crimp machines not used for the particular products of a family. Again, while maximizing machine utilization is not a goal of cell design, efficiently distributing existing machines among the cells helps reduce the investment required to implement the new production system design.

Considering these two attributes, the end models into ten families, as can be seen in Figure 4.4. Each family is referred to by these initial characteristics, one being the “Aluminum, 2 crimp” family, another the “Aluminum, 4 crimp” family, and so on. Taken as a whole, the ten families are referred to as the Large Families, since subset families were later formed within each family. The results of the Large Family groupings are summarized in the first column of Table 4.2.

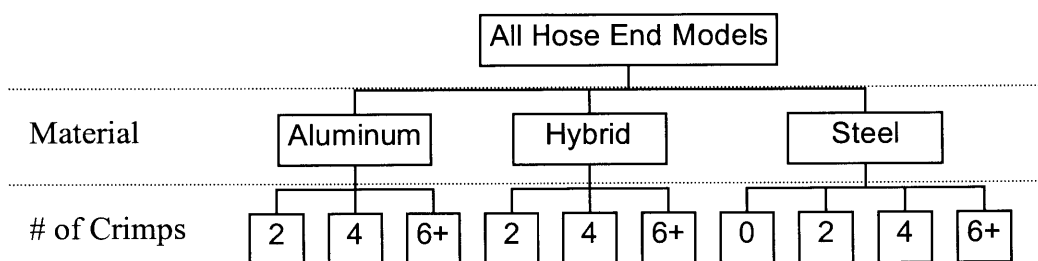

Figure 4.4: Large Families formed on the basis of material type and crimping

Table 4.2: Summary of Large Families

	# of models in family	# of cells for family	# of shifts cells will run	avg Takt time for cells (sec)	% of total cells	# of crimp machines
Family 1 - Al or St, 0 crimp	5	1	2	36	4.2	0
Family 2 - Al, 2 crimp	14	9	2	32	33.3	9
Family 3 - Hybrid, 2 crimp	9	3	2	39	12.5	3
Family 5 - Al, 4 crimp	11	3	2	39	12.5	6
Family 6 - Hybrid, 4 crimp	30	7	2	30	25.0	14
Family 9 - Hybrid, 6+ crimp	4	2	2	35	4.1	7
Family 8 - Al, 6 crimp	5	1	1	49	2.0	3
Family 4 - St, 2 crimp	3					
Family 7 - St, 4 crimp	2					
Family 10 - St, 6 crimp	2	1	1	45	2.1	
						42

12% of volume {

Looking at the Large Families, it is possible to form a rough sketch of the assembly cell requirements. One of the most striking features of the Large Family summary is the high volume associated with the “Aluminum, 2 crimp” family, which represents one third of all hoses produced, despite having only half as many end models as the “Hybrid, 4 crimp” family. It is also interesting to note that six families, the all steel product families plus the hybrid and aluminum 6 crimp families, account for only 12% of the total volume of hoses. This low volume suggests that forming cells to run these particular products is of low priority, and that the real focus should be on forming cells for the aluminum and hybrid, 2 and 4 crimp models.

By taking the aggregate demand for products in each family, the number of cells required per family was estimated by assuming that all cells will run two shifts. The need to run a second shift is the same as in the case of the demo cells, in that the volumes demanded are so high that if only one shift is run, then one of the following scenarios results:

1. twice as many cells are needed in order to operate each cell at a takt time greater than 30 seconds. This increase in the number of cells means a significant increase in investment.
2. the total number of cells is unchanged, but the takt time of each is cut in half. As mentioned earlier, cells with takt times lower than 30 seconds are not volume flexible if demand increases and also make it difficult to realize many benefits the cell is intended to offer such as separating the worker from the machine.

The results of these calculations are shown in the second and fourth columns of Table 4.2. In the case of the three steel product families and the “Aluminum, 6+ crimp” family, the volumes did not justify each of these families having its own assembly cell. Thus, in keeping with the effort to reduce the number of crimp machines used per cell, it was decided that the four families should be run together in a single cell operating two shifts.

Knowing the number of cells required per large family and making the same assumptions with regard to the crimp machines being capable of:

1. making two crimps of the same diameter and
2. crimping both steel and aluminum,

it was possible to calculate the number of crimp machines required by each family (sixth column of Table 4.2). Prior to performing this calculation, Coclisa had assumed that the number of crimp machines required to fully convert final assembly to cells would exceed the number currently owned. However, the assumption proved false, and forming product families with the intention of minimizing the number of crimp machines per cell actually meant the company would have four extra machines once cells replaced the assembly lines. With the knowledge that

there was not an equipment constraint in final assembly, an interim plan was proposed such that work could begin immediately in this area.

4.5.2 Subset Families

Estimates gathered from analysis of the Large Families proved that a sufficient number of crimp machines were on hand to begin the conversion of final assembly to cells. However, before any cells could be designed, there was still a need to further subdivide each of the Large Families to determine which products would run in a specific cell. For example, the “Aluminum, 2 crimp” family is made up of fourteen end models and requires approximately nine assembly cells, but this information is not enough to determine which of these end models should run together in each of the nine cells. Thus, within each of the Large Families, Subset Families were formed.

The product characteristic used for determining the next level of resolution was the brazing requirement. Given that current braze machines are not acceptable for use in the cell, there is already a need to purchase newly designed ones, and minimizing this investment was deemed critical to continuing the conversion. The emphasis is not on running machines non-stop, as fast as possible, for the sake of machine utilization, but rather on using the machine effectively within each cell. For example, if it was decided that four products should run in the same cell, of which only one required brazing, a brazing machine is still required in that cell, and it is this type of situation that would be considered inefficient use of the machine. Thus, the end models within a Large Family were divided according to the total number of aluminum brazes required—0, 1, 2, 3+. In this way, products not requiring brazing could run together and the cell would not require a machine, while product with the same number of brazes could have a matching number of machines in the cell.

The fourth, and last, characteristic used for forming the Subset Families was hose diameter. This feature was chosen because it dictates the amount of changeover required on the forming and crimping machines. At this level, a major aim of the product family formation was to group products such that changeover could be minimized and, if possible, eliminated. Given that changeover of the forming and crimping dies was not completely eliminated within all Subset Families, it is still necessary to investigate ways to reduce setup time on these machines. However, by minimizing changeover frequency, the need to reduce setup time does not become a major obstacle to the initial performance of the cell. Thus, in the transition stage, where cells are being implemented but setup time is yet to be reduced, it is possible to run products of one type during the first shift, perform a changeover between shifts, and run another type in the second shift. While this strategy means that some cells will not be leveled by mix, it enables the cell to be physically in place and capable of meeting production requirements until such a time that the full range of products can be run to follow customer demand.

The entire classification scheme used for forming product families is shown in Figure 4.5, with the third level representing the total number of aluminum brazes per end model, while the last level represents hose diameter. In the case of “2 crimp” models, only one hose diameter is listed since both tubes making up an end model are of the same diameter. Meanwhile, the “4 crimp” models are subdivided on the basis of two hose diameters since it is common for these models to have two different hose diameters.

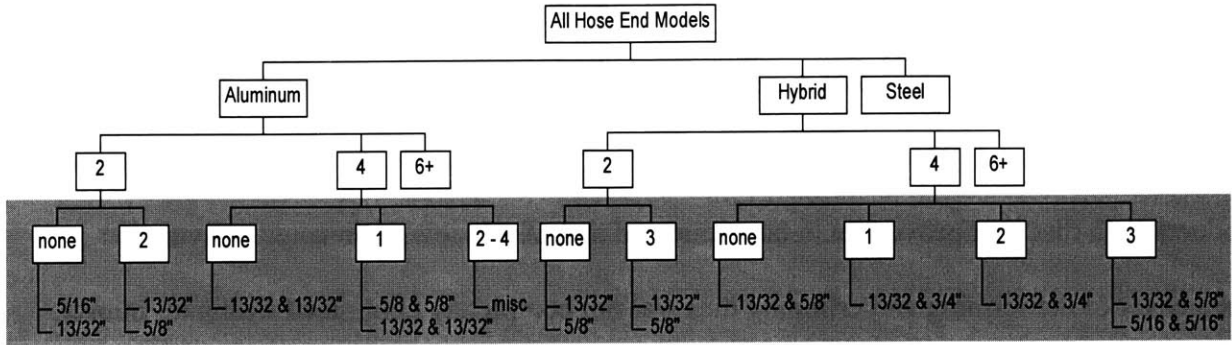

Figure 4.5: Product Family Tree. Highlighted levels show subset families with the third level representing the number of brazes and the fourth level the hose diameter.

Using the same calculations and cell design considerations as those discussed for the Large Families, it is possible to get a more detailed picture of what each assembly cell will run. However, in columns 3 and 4 of Table 4.3, the aggregate demand within a Subset Family is being used to determine the number of cells to be required. In most cases, where a subset family requires more than one cell in order to have a takt time over 30 seconds, the cells are designed to be identical. For instance, Family 2A is made up of only two end models, and thus all three assembly cells will be designed to run both of the products. In a few other cases, a Subset Family may still be further subdivided based on unique features such as braze type, and each of the assembly cells for that family may run different products.

Given that families are formed on the basis of the number of crimps required, this same factor also determines the number of tubes that are comprised the model, as governed by the following equation:

$$\text{Number of Tubes} = \frac{\text{Number of Crimps}}{2} + 1$$

where the number of crimps is a multiple of 2. By knowing the number of tubes feeding into the each of the assembly cells to be formed, a rough plan for the formation of all cells within the

manufacturing system, in both fabrication and assembly, can be formed. The plan for the complete conversion of the manufacturing system is referred to as the ideal design, and will be the focus of a subsequent section.

Table 4.3: Summary of Subset Families

Subset Family	% of Total Volume	Takt Time	# of assy cells
Family 1 - St, 0 crimp	3.8	39	1
Family 2 - Al, 2 crimp	35.6		
2A: 5/16, no Al braze		35	3
2B: 13/32, no Al braze		34	4
2C: 13/32 & 5/8, with 2 Al brazes		51	2
Family 3 - Hybrid, 2 crimp	11.3		
3A: 13/32, no Al braze		35	1
3B: 5/8, no Al braze		30	1
3C: 13/32 (& 5/8), with 3 Al brazes		64	1
Family 5 - Al, 4 crimp	9.9		
5A: 13/32,13/32, no braze		35 (1st shift)	0.5
5B: 5/8, 5/8, with 1 Al braze		47 (2nd shift)	0.5
5C: 13/32,13/32, with 1 Al braze		45	1
5D: misc diameters, max 4 brazes		47	1
Family 6 - Hybrid, 4 crimp	27.7		
6A: 13/32,5/8, no braze		32	2
6B: 13/32,5/8, with up to 3 Al brazes		39 (1st shift)	
6C: 5/16, 5/16 with up to 3 Al brazes		37 (2nd shift)	1
6D: 13/32, 3/4 with 1 Al braze		48	1
6E: 13/32, 3/4 with 2 Al braze		37	3
Totals	88.3		23
Family 9 - Hybrid, 6+ crimp	8.6	34	2
Family 8 - Al, 6 crimp	1.6	49 (1st shift)	1
Family 4 - St, 2 crimp	0.9		
Family 7 - St, 4 crimp	0.4	45 (2nd shift)	
Family 10 - St, 6 crimp	0.3		
Totals	100		26

4.6 Estimates of Worker and Equipment Requirements

Using the demo cells as a reference, the formation of the Subset Families allowed for fairly accurate estimates to be made as to equipment and the number of workers needed in the new

cells. These estimates were crucial to the continuation of the conversion process since they pointed toward expected savings that more than cost justified the investment in new fabrication equipment. Estimates for the number of direct workers are provided in Appendix A, while equipment estimates can be found in Appendix B.

4.7 Interim Plan

Given that the existing crimp machines are suitable for use in cells without any need for redesign, and that there are a sufficient number on hand, an interim plan calling for the complete conversion of final assembly to cells was proposed. With the subset families in place, the design of specific assembly cells could begin, and the next level of planning involved prioritizing the cells to be implemented. Due to low volume, the steel end models and those with 6 or more crimps were given low priority. Thus, the choices to be made were mainly between aluminum and hybrid, two and four crimp models.

A decision to first form cells for the “Aluminum, 2 crimp” family was made for three reasons. First, aluminum products were chosen over hybrid ones to postpone the need to find a common crimping spec between steel and aluminum tubes. Second, the demo cells belonged to this family, and thus could serve as a reference while Coclisa worked on its first cell designs for the new system. Lastly, and stemming from more long term thinking, seven of the nine assembly cells required for this family do not need to be fed by fabrication cells with brazing machines. Thus, if fabrication cells are implemented in the same order as the assembly cells, then the first ones will be simple since no brazing is necessary. Planning for the first fabrication cells to be those that do not include brazing machines also means that more time can be spent designing the new machine.

The next family to be converted to cells would be the “Steel, 0 crimp” family. Since the cell requires no crimp machines, it should be fairly easy to implement. The third family to be converted is the “Aluminum, 4 crimp” family. The reason for choosing it over the “Hybrid, 2 crimp” family is again to allow more time to find the common crimping spec between steel and aluminum. Unless this crimping spec is changed, the “Hybrid, 2 crimp” cells will require two crimp machines, one for each material type. The cells for the “Aluminum, 4 crimp” family will also be largely based on the demo cells, but will make use of two crimping machines—with each machine making two crimps. In this family, it is necessary to prepare three tubes for the assembly of the model, and the tube prep section of the cell may differ from that of the demo cells (see Figure 3.4).

The entire interim plan is as follows:

1. Design and implementation of cells for the “Aluminum, 2 crimp” family
2. Design and implementation of cells for the “Steel, 0 crimp” family
3. Design and implementation of cells for the “Aluminum, 4 crimp” family
4. Redesign of St manifold, making most “Hybrid, 4 crimp” models into “Aluminum, 4 crimp”
5. Design and implementation of cells for the newly formed “Aluminum, 4 crimp” family
6. Design and implementation of cells for the “Hybrid, 2 crimp” family
7. Design and implementation of cells for any remaining “Hybrid, 4 crimp” family
8. Design and implementation of cells for the “Hybrid, 6+ crimp” family
9. Design and implementation of cell for the “Aluminum, 6+ crimp” and Steel families

Although the redesign of the steel manifold is listed as step 4, the intention is that this task be carried out in parallel with steps 1 through 3 such that it may be complete when cells for the original “Aluminum, 4 crimp” models are in place.

The expected savings of implementing the interim design are highlighted in Table 4.4. The largest source of savings comes through the reduction in the direct labor, which is calculated to be roughly three times less in the new manufacturing system. However, this major cut is not entirely surprising since the demo cells alone showed a 33% decrease in the number of direct workers. Other significant savings come from the reduction in scrap anticipated in the interim system. The scrap figure presented is based on the scrap of the demo cells collected in the four-month period after their installation, and is believed to be reliable. It is also important to note the 12 minute throughput time in assembly for the interim system. This throughput time is the result of bending not being integrated into the assembly cells during the interim phase since these machines require major redesign (discussed in section 5.3.4). Bending will become part of the assembly cell in the ideal phase.

Table 4.4: Comparison of the Current and Interim Systems

(only final assembly is converted to cells and bending is not part of these cells)

Features		Current	Interim
Production		~7,000,000 pcs/year	~7,000,000 pcs/year
Assembly Production			
	# of cells	4	26
	# of assembly lines	11	0
	# of benders	132	132
	# of crimping machines	46	42+ 4 (stuck on line) + 4 (new for ease of implementation)
	# of leak testing machines	28	26 + 2 (stuck on line) + 4 (new for ease of implementation)
Floor Space (sq. ft)		163,140	112,124
Total Direct Workers (all shifts)		526 (assy) + 98 (bend) + 429 (fab)	160 (assy) + 98 (bend) + 429 (fab)
Total Indirect Workers (all shifts)		60 (assy) + 16 (bend) + 99 (fab)	74 (assy & bend) + 99 (fab)
Total required man-hours per year		2191980	1350720
Yearly Fab Scrap Expenses		\$540,000	\$540,000
Fab WIP		variable (~ 64,000)	variable (~ 64,000)
Yearly Fab Throughput Time		variable (~1 day)	variable (~1 day)
Assy Scrap Expenses		\$135,000.00	\$45,000
Assembly WIP		variable (~1800)	81 (3 pcs per cell)
Assembly Throughput Time		variable (~1 day)	11 - 12 min

4.8 Ideal Plan

While the interim design will involve a great deal of work, it is only the first phase of the larger scale plan to convert the entire manufacturing system at Coclisa. In the next phase, also referred to as the ideal plan, the formation of cells in the fabrication area is the first major step, followed by linking of the fabrication and assembly cells. The general strategy being sought for

the linkage of fabrication and final assembly is to have the number of fabrication cells equal the number of tubes required by the end models being assembled. In the case of 2 crimp models, two tubes are needed, while 4 crimp models are comprised of either three tubes or two tubes and a manifold subassembly. Assuming that the manifold subassembly – the manifold and two connecting tubes – can be converted to aluminum, then a single fabrication cell will need to process both tubes and braze the entire subassembly since the subassembly is brazed on a single fixture. Figure 4.6 shows the general strategy for the cases of two and four crimp end models.

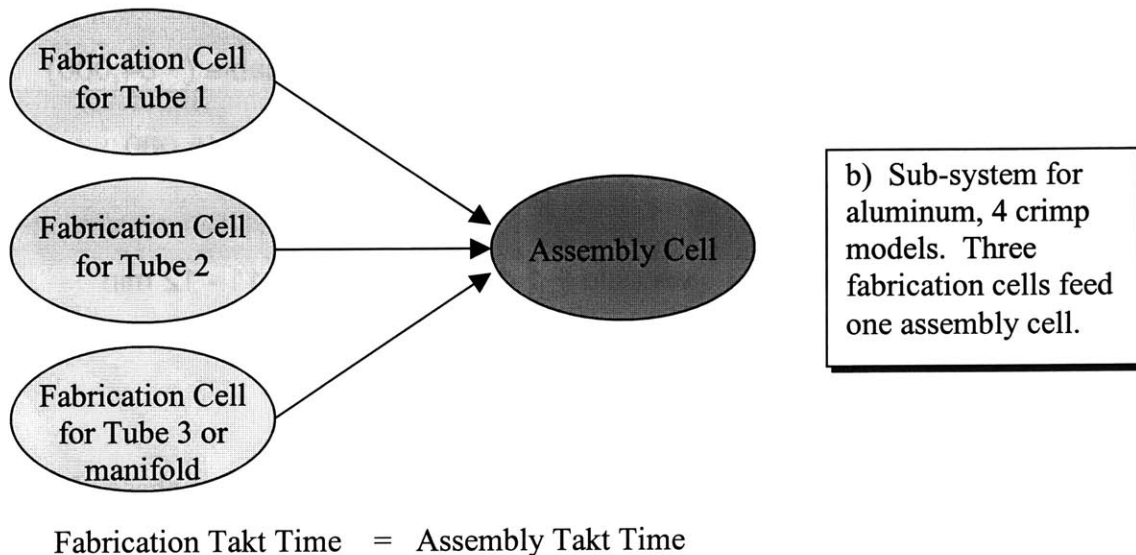
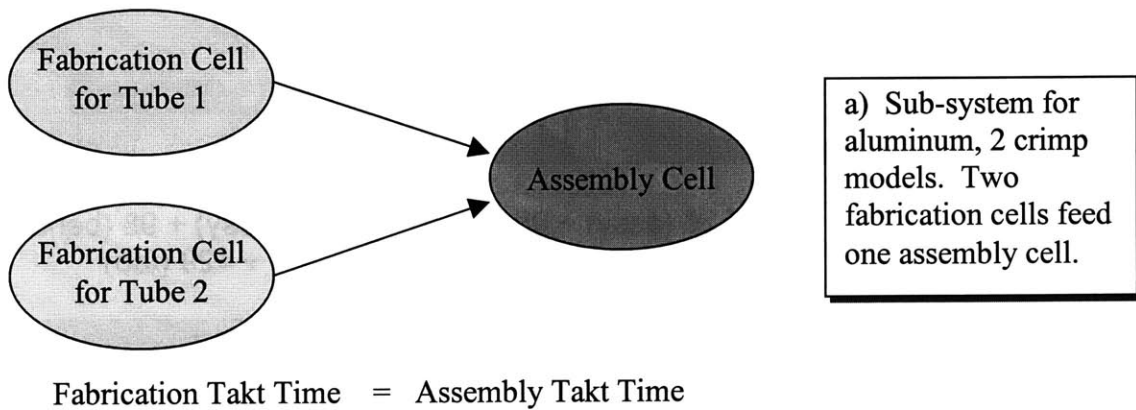

Figure 4.6: General strategy for Linking Fabrication and Assembly Cells

Upon completing implementation of the ideal plan, all final assembly cells will include bending machines. The cells requiring aluminum tubes will be fed by fabrication cells. Meanwhile, steel tubes will continue to be supplied by the fabrication department. The expected savings at this point in the conversion process are summarized in Table 4.5.

It should be noted that the equipment design portion of the ideal phase overlaps with the design and implementation of assembly cells in the interim phase. See Figure 4.7. In this way, implementation of the fabrication cells can begin shortly after the assembly cells are in place. If the full benefits of the assembly cells are to be realized, then feeding the cells with consistent quantities based on takt time becomes essential. This scheduled feeding of the desired quantity to be consumed reduces the work-in-process (WIP) inventory outside of the assembly cells, and more importantly, should increase the quality of the end product.

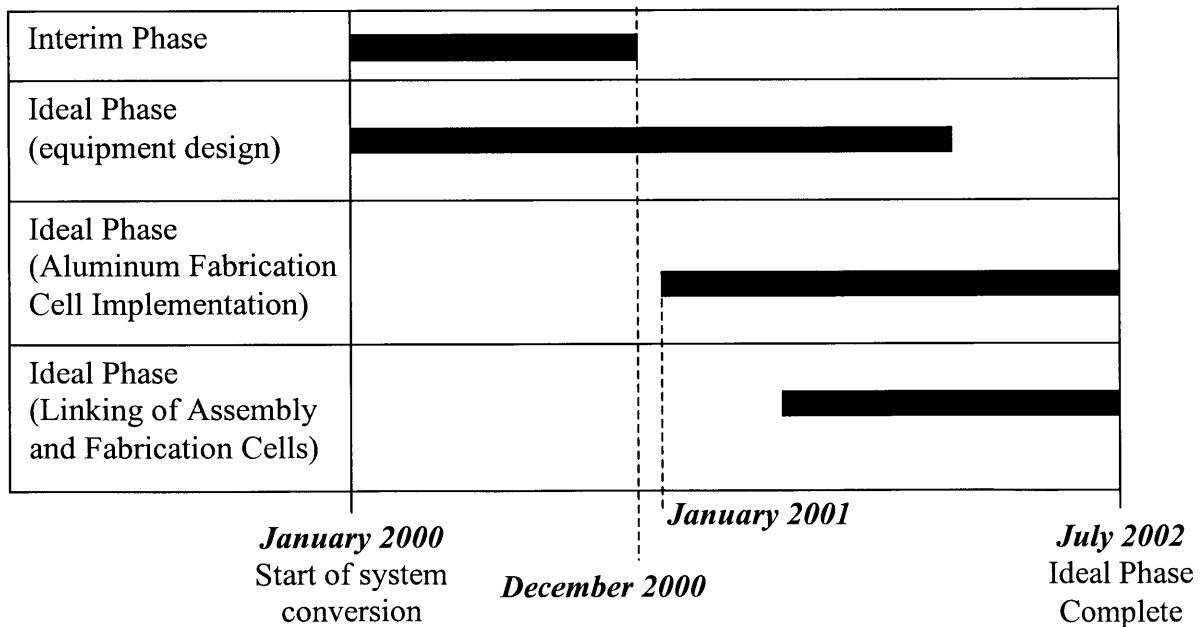

Figure 4.7: Schedule for completion of the interim and ideal phases of conversion

Upon completion of the ideal phase, it is estimated that the assembly room of the San Lorenzo plant (refer to Figure 1.3) is sufficient to house the entire linked-cell manufacturing system, as shown in Figure 4.8. The estimates used to calculate the floor space requirements are based on the dimensions of the demo cell, while estimates of the aluminum fabrication cells are based on the dimensions of the current forming machines and assumptions about the new brazing and washing machines. This proposed layout does not account for the fabrication of steel tubes, and assumes the tubes will be processed in departments until being phased out. Thus, it is assumed the steel tubes needed by the assembly cells will continue to be fed in large batches.

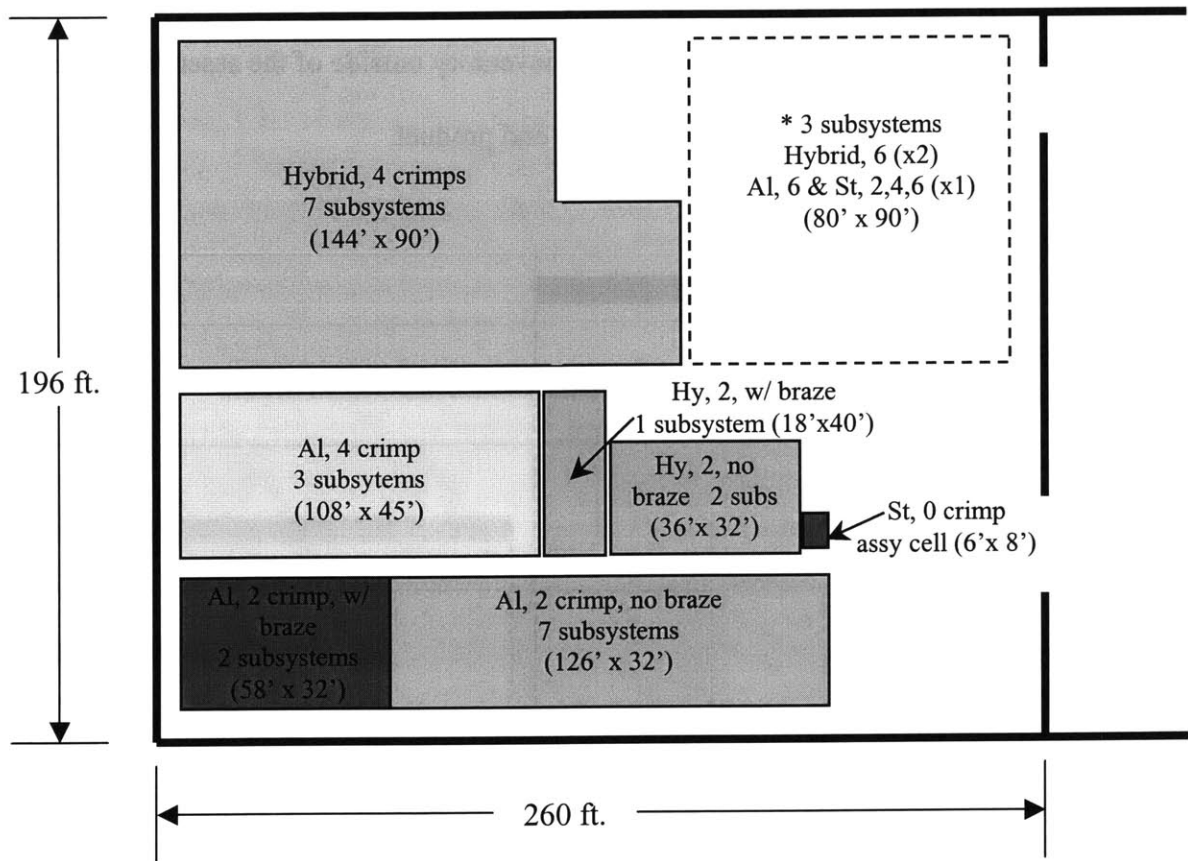

Figure 4.8: Layout of Ideal System can be accommodated by assembly room at San Lorenzo plant.

Table 4.5: Comparison of the Current and Ideal Systems

(Aluminum fabrication cells formed and linked to assembly cells formed in interim)

Features		Current	Ideal
Production		~7,000,000 pcs/year	~7,000,000 pcs/year
Fab Production			
	# of Aluminum fab cells	0	41
	# of tube cutoff machines	10	5 + 3 (St fab)
	# of formers (3 stroke)	56	82 + 17 (St fab)
	# of formers (6 stroke)	23	36 + 7 (St fab)
	# of groovers (ferrule)	21	41 + 7 (St fab)
	# of groovers (end cage)	4	21 + 1 (St fab)
	# of piercing machines	13	10 + 3 (St fab)
	# of washers	5	41
	# of Aluminum brazers	16	29
Assy Production			
	# of cells	4	26
	# of assembly lines	11	0
	# of benders	132	70
	# of crimping machines	46	82
	# of leak testing machines	28	26
Floor Space (sq. ft)		163,140	51352
Total Direct Workers (all shifts)		623 (assy & bend) + 232 (Al fab) + 198 (St fab)	160 (assy & bend) + 141 (Al fab) + 198 (St fab)
Total Indirect Workers (all shifts)		76 (assy & bend) + 45 (Al fab) + 54 (St fab)	140 (Al assy, bend, & fab) + 54 (St fab)
Total required man-hours per year		2191980	838320
Yearly Fab Scrap Expenses		\$540,000	\$80,500
Fab WIP		variable (~ 64,000)	285 (~7 per fab cell)
Fab Throughput Time		variable (~1 day)	4 min
Yearly Assy Scrap Expenses		\$135,000	\$7,000
Assembly WIP		variable (~1800)	78 (3 per assy cell)
Assembly Throughput Time		variable (~1 day)	2 min

4.9 Conclusions

In the case of Coclisa, the formation of product families based on manufacturing processing, as opposed to the final customer, was appropriate since individual customers require very different products. Attempting to run these products in a single assembly and/or fabrication cell would lead to unnecessary complexity in the design of both the cells and the fixtures within them. Another benefit to forming families based on processing is that it allows decisions to be made in accordance with machines considered important. For example, the crimping machine was important to the success of the assembly cells, as it is the only major piece of equipment in these cells. In terms of the fabrication cell, the braze machine was deemed important since it needs to be completely redesigned. And in order to minimize the complexity of the new design, special considerations could easily be made during the family formation process.

Beyond comparison with the customer-based method for forming product families, the processing-based method has several other benefits. First, as newly designed end models enter the manufacturing system, their place is automatically known, making them easier to handle. Second, the manufacturing system becomes more intuitive for the product designers, and when designing products of a certain family type, understanding of their manufacture is made easier. Third, it becomes possible to allocate support personnel, such as engineers and production supervisors, along the lines of the product families (discussed in section 5.5). This type of structure facilitates communication and can lead to more complete solutions when problems arise.

5 Changes Required to Achieve the Ideal Design

5.1 Intro: Areas of Change

In order to implement the ideal manufacturing system design outlined in the previous chapter, it is critical that Coclisa take the following four steps:

1. Eliminate the non-value adding operations of leak testing in assembly and post-wash inspection in fabrication,
2. Redesign the equipment for aluminum processing so that it is cell compatible
3. Complete the conversion of steel parts to aluminum, and
4. Reorganize personnel to support production based on product families.

Each of the above steps requires a great deal of effort, and it is not expected that Coclisa will be able to move quickly on any one item. However, to the company's advantage, steps 1, 2, and 3 can be pursued in parallel, and thus the time to implement the new system can be shortened. Once the physical system is in place, teams based on product families can be formed.

The generic structure of the linked-cell subsystems that will make up the overall manufacturing system are shown in Figure 5.1. The number of fabrication cells will equal the number of tubes required by the final assembly so that all cells making up a subsystem can operate at the same takt time. It is important to note that in the ideal plan bending is physically integrated into the assembly cells, and each fabrication cell has a washing machine. Thus, for the cells in Figure 5.1 to be implemented both of these machines will need to be replaced, while all other machines will require some amount of modification.

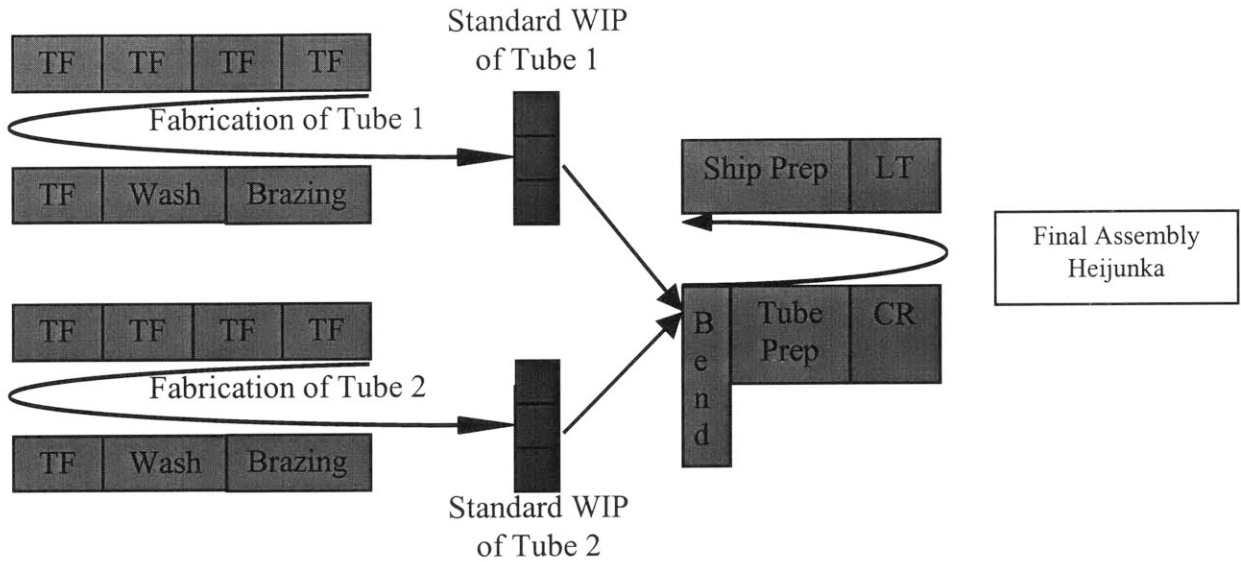

a) Sub-system for aluminum, 2 crimp models. Two fabrication cells feed one assembly cell.

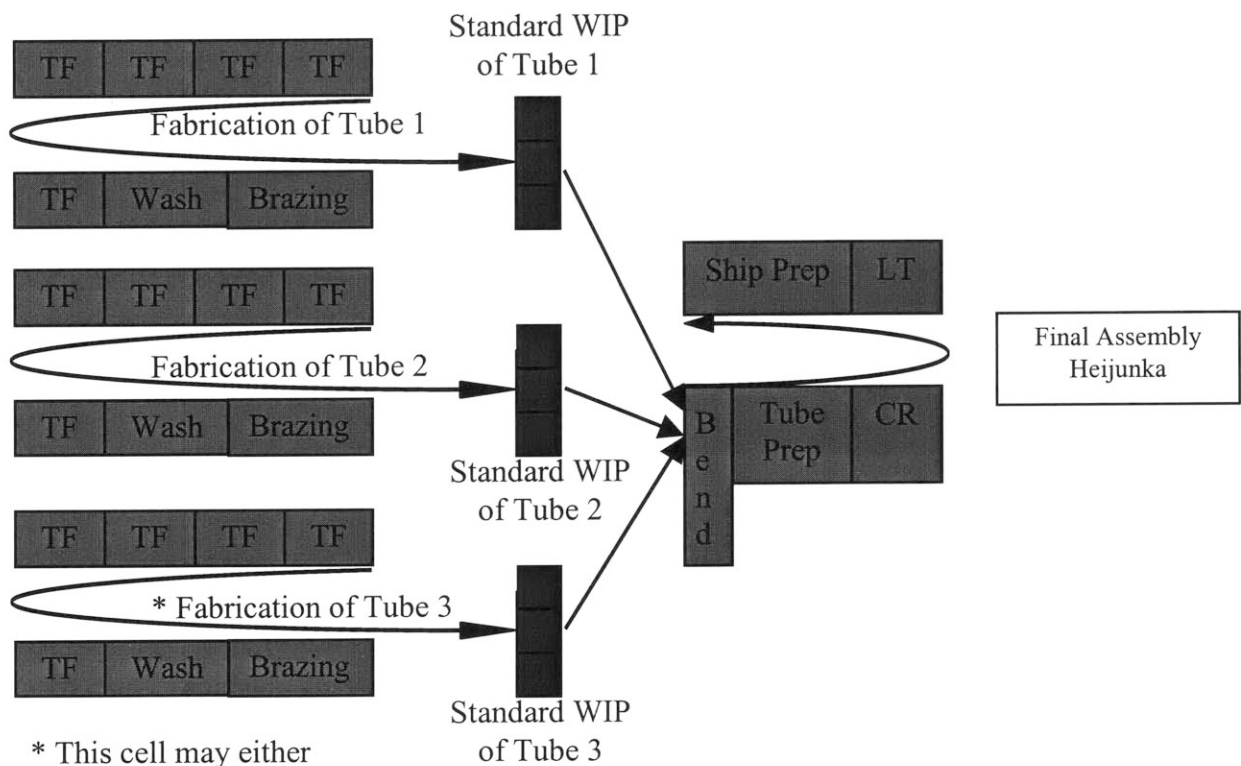

* This cell may either fabricate a single tube or the entire manifold subassembly

b) Sub-system for aluminum, 4 crimp models. Three fabrication cells feed one assembly cell.

Figure 5.1: Linked-cell subsystems pursued in the ideal plan. Arrows show part flow, while information is flowing in the opposite direction.

5.2 Non-Value Adding Processes

While there are several wasteful operations in the current system, the cellular approach being proposed will reduce, and in many cases eliminate, the wastes associated with excess transport and storage. Thus, the last set of non-value adding operations that require analysis, for the purpose of elimination, deal with inspection. In the case of Coclisa, these operations refer to leak testing in final assembly, and post-wash inspection in fabrication.

5.2.1 Leak Test

The elimination of the leak test was sought during the formation of the demo cells. The motive stems from the fact that while the task of leak testing itself is a non-value-adding operation, the preparation necessary to perform the leak test requires that four more non-value-adding steps be taken. These steps include plugging the assembly's ends with process fittings, loading it with helium, and after the leak test is complete, unloading the helium, and finally removing the process fittings. As a result, in the three-operator cell with a 24 second takt time, one operator is entirely devoted to the task of leak testing. Thus, if leak testing is eliminated, then an operator is available to work elsewhere in the plant or provide the cell with support in the form of implementing improvements.

Another problem with the current method of leak testing is that the helium "sniffer" used to detect leaks is very sensitive, and is easily damaged. Consequently, it is necessary to test the condition of the sniffer throughout the shift as a form of preventive maintenance. Even with frequent checkups, it is still quite common for the sniffer to become damaged during use, in which case production must stop. Again, creating a situation that is not appropriate for cells, or the assembly line for that matter, since their proper function depends on the equipment being reliable and available.

Aside from the requirements imposed by the cell, another fact that led to a desire to eliminate leak testing is that in the two years that Assembly Line 4 had been running, there was no recorded instance of a product failing the leak test. This fact can be interpreted in one of two ways – 1) either the assemblies do not leak, in which case the usefulness of the test is subject to question, or 2) the current method for leak testing is not capable of detecting leaks. Regarding the former, two reasons were cited for leak testing on line 4, despite no occurrence of leaks. First, other assembly lines had detected leaking hoses, and thus the Quality Department insisted that all lines follow the same process. A study of why some lines had leaks, while others were leak-free was never pursued. Second, it was a “customer requirement.” Most likely, this requirement is the result of a “customer complaint” after having received a leaking hose in the past. However, as long as the customers can be assured that the products they receive will not leak, they would most likely not object to the elimination of a testing operation that raises cost.

As for the latter, concerning the capability of the current leak process, there are two reasons the test itself should be questioned. First, at Coclisa, the operation has no established standard for the length of time an operator should spend testing each hose. Second, there are different opinions as to what areas of the hose the operator should focus on when sniffing for leaks. Some engineers felt it is only essential to leak test the joints formed by brazing and crimps, while others said it is also necessary to inspect along the length of the tubes and hose. The argument against testing braze joints in final assembly is that they had already been leak tested prior to being delivered to the area; an entire assembly line is devoted to the leak testing of brazed tubes. However, that still leaves the tube, hose, and crimp joint to inspect. In the case of the tube, it is believed that if the surface is scratched during the fabrication process this scratch may be a source of leaks. As for the hose, the supplier’s method of production, in which the outer sleeve

of the hose is pricked to release trapped gases, is believed to be a known source of leaks along the hose. Lastly, no good reasons were offered as to why the crimp joint should be tested, other than a belief that all joints run the risk of leaking.

Ideally, the leak test would be entirely eliminated by correcting the sources of leaks. The goal should be to understand where, during the fabrication process, the tube could be scratched, and measures should be taken to prevent these occurrences. Situations in which the supplier ships leaking hoses should simply not be tolerated, and it is the job of the supplier, not the customer, to find the leaks. As for the crimped joints, tests need to be conducted to assess whether or not these joints are truly a potential source of leaks.

If it is determined that leak testing cannot be eliminated, then several improvements can be made regarding the capability and accuracy of the inspection, and the process should also be designed for use in the cell. After initial brainstorming, the best concept to emerge involved filling the assembly with helium, and then placing it in a sealed “box” for a set amount of time to detect the leaks. In this way, the entire hose is tested at once, and the subjectivity as to what parts of the assembly the operator should test is eliminated. Also, the testing time for a particular product could be standardized, which is currently not possible since the operator always has the option of rushing the sniffing process if the need arises. The major drawback to the current concept is that it still requires the assembly to be filled with helium, and thus the other four non-value-adding steps are still required.

5.2.2 Post-Wash Inspection

As discussed in the Chapter 1, the need for post-wash inspection arises from the fact that the current washing process damages and/or leaves parts oily. Thus, in order to eliminate post-

wash inspection, attention should be focused on the washing process. Washing itself could be eliminated if the tubes were not contaminated with oil during the cutoff and forming processes.

If it is found that some amount of oil is required in the cutoff and forming machinery, then two alternatives are suggested. First, the possibility of using either water-soluble or vanishing oils that do not require detergent washing should be investigated. The company needs to define the level of cleanliness required such that brazing quality will not be affected. These cleanliness standards will be significant to the design of the next generation of washer. Second, it is suggested that oil be applied in controlled amounts and only at the point required. In all instances, only about an inch of the tube's ends are affected during cutoff and forming. As for the forming machines, the current method of application is to have the operator dip the tube's end in a container of oil prior to loading it into the machine. During the handling, transport and storage the oil eventually coats the inner and outer walls of the tube. If oil can be limited to the point of use and applied accordingly, the washing process would be greatly simplified.

The batch size of tubes arriving from the forming department, along with the need to wash the tube over its entire length are the main reasons for the design of the current washer. First, the size of each wash station is dictated by the longest tube that needs to be washed, since the basket holding the tubes must rotate within each bath. Meanwhile, the departmental system supplies parts to the washer in large bundles, and thus the desire to continue processing in batches leads to the design of the rotating basket. At the same time, the amount of oil on the tubes requires the washing process to include a pre-soak station to assist in removing the bulk of the oil.

To correct many of these drawbacks, the washer to be used within the new manufacturing system should be designed to have the following characteristics:

- wash one piece at a time

- only wash the tube ends
- load the part vertically
- be less than 4' in width, to reduce walking time of the operator
- only be comprised of wash, rinse, and dry stations
- meet the takt time

One conceptual design of the new washer machine is to load the part vertically so that the length of the tube does not affect machine size. Also, the machine could have an overhead spray gun that attaches to the tube end, and can be used to flush the tube's interior and wash the ends' exterior. A diagram of the conceptual machine is shown in Figure 5.2.

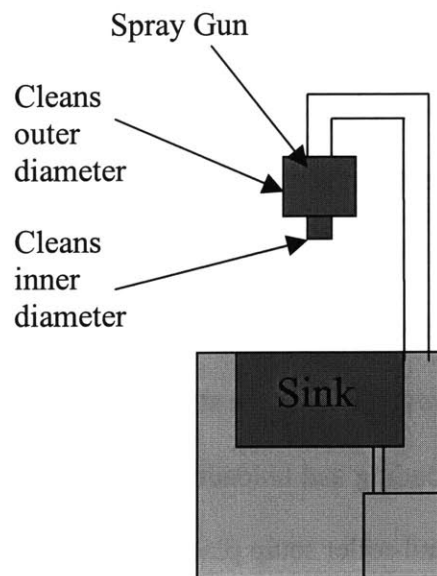

Figure 5.2: Conceptual design of a cellular washer

5.3 Redesign of Equipment

The redesign of fabrication equipment, in particular the brazing machines, is critical to the success of the entire manufacturing system being converted to cells. Forming fabrication cells

out of current equipment is not feasible because overall it is inflexible, designed to run at a cycle time of 10 seconds or less, and assumes a worker will be tied to the machine.

5.3.1 Tube Cutoff

The new tube cutoff machine design should avoid the use of oils to index and cut the part. As mentioned earlier, oil is applied to the spool stock to reduce friction between it and the nylon roller (see Figure 1.4). The roller serves as a tension relief by sliding linearly toward the machine during indexing, and then sliding back to take the slack out of the stock. It can be assumed that some sort of tension relief is always necessary to avoid damaging the stock, and so simply removing the roller to avoid oiling may not be possible.

However, there are currently two options for reducing friction. The first alternative is to find a material which has a lower coefficient of friction than nylon and is feasible for use as a roller. The second option deals with reducing the amount of stock that is in contact with the roller at any one time. In the current setup, the stock is in contact with half of the circumference of the roller. In order to reduce this contact length it is necessary to place the aluminum spool above the nylon roller, in which case the stock would only be in contact with one-fourth the circumference. See Figure 5.3. However, having the stock fed from above the roller may introduce problems associated with loading and unloading the spools. It is probably more feasible to have the proposed spool-and-roller setup placed horizontally such that the entire mechanism, shown in Figure 5.3, is rotated by 90°. In this way, the aluminum spool can remain at a height equal to the cutoff machine, and similar to that of the current setup.

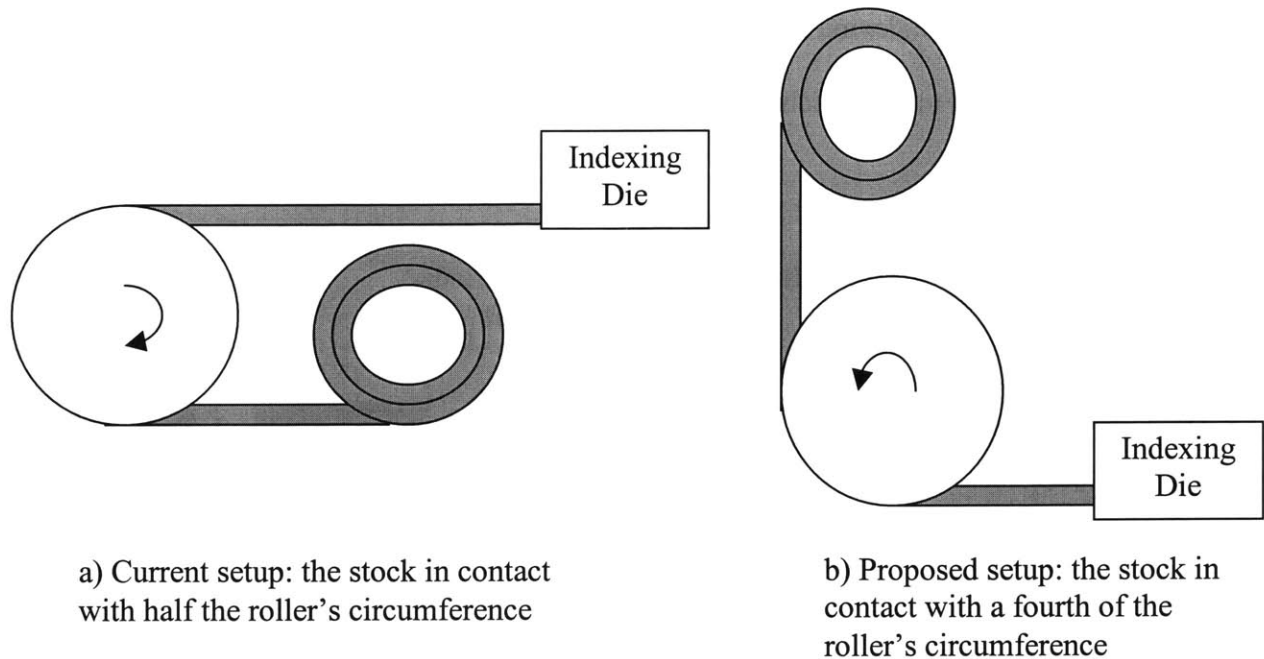

Figure 5.3: Orientation of spool with respect to the tension relief roller.

Oil is also applied to the entire aluminum spool to aid the indexing die of the cutoff machine. In the current design there are two dies that ensure the tubes are cut to the correct length. One die is stationary and keeps the stock centered, while the indexing die grabs the part and slides linearly to advance it toward the cutter. When the indexing die reaches the stationary die, a sensor is activated and signals the cutter. The setup is shown in Figure 5.4. The indexing die is made up of two jaws such that the stock is advanced when the jaws are closed, and as the indexing die travels away from the stationary die with the jaws open.

The need for oiling the length of the tube arises because in the open position only the top jaw is raised, and the lower jaw of the indexing die remains in contact with the stock. The reason quoted for having the lower jaw remain in contact is to keep the stock centered. However, having the lower jaw serve this purpose is redundant since the stock is being kept centered on either side of the indexing die. A series of straighteners at the start of the machine align the stock prior to the indexing die (see Figure 5.5), and the stationary die does the same at

the other end. Thus, the indexing die could operate such that neither jaw was in contact with the stock in the open position. In which case, the second reason for using oil on the tube cutoff machine is eliminated.

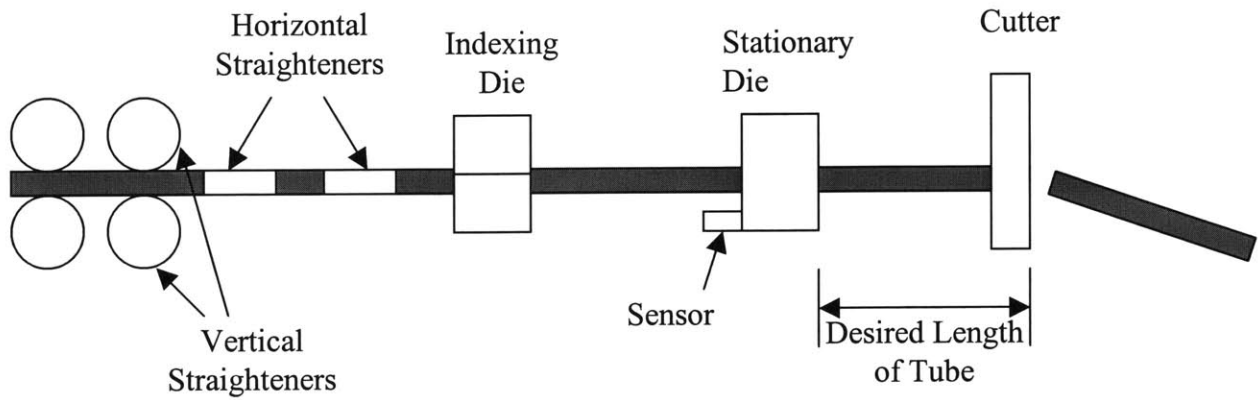

Figure 5.4: Indexing and cutting mechanism of current cutoff machine.

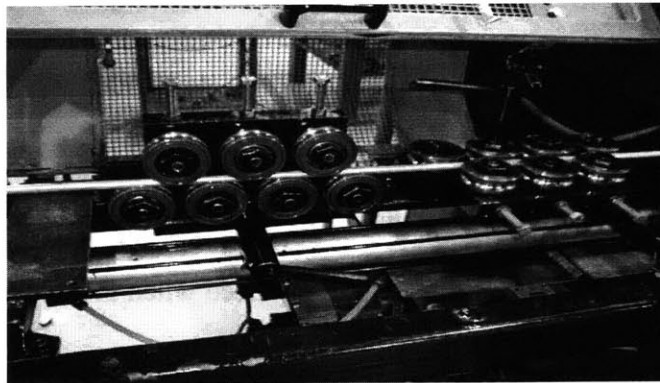

Figure 5.5: Straighteners at the start of the tube cutoff machine.

The last place oil is used within the cutoff machine is at the cutting blade. At this location, however, the oil is intended to serve as a coolant rather than a lubricant. Thus, replacing the oil, with a water soluble coolant is relatively easy because most coolants have this attribute. On the

current machine, the use of oil at the cutting blade is not given much thought since the part is already covered in oil by the time it is to be cut. The water soluble cutting fluid allows the tubes to be cleaned through a simple rinsing process.

5.3.2 Forming

As with the cutoff machine, a major aim of the newly designed forming machines is to eliminate the use of oils. However, unlike the tube cutoff machines, the forming machines will be part of fabrication cells, and thus must meet certain criteria to be made compatible. The current forming machines have cycle times on the order of 6 to 8 seconds, and in the departmental layout it is most logical to have one operator per machine. As such, the machines are designed with a seated operator in mind. Thus, one recommended modification is that the machine be raised to a convenient height such that a walking worker can easily load the tube.

Other modifications regarding cell compatibility deal with minimizing the width of the machine in order to reduce the walking time of the cell operator. In the current design, a control panel and tank are located on either side of the machine extending the overall width by about two feet. These components should be relocated. One suggestion is to have the control panel placed above the machine and the tank below. In placing the control panel above the machine it becomes necessary to reduce the height of the protective steel cage (for a picture of the protective cage refer to Figure 1.7) enclosing the machine die. It is important to note that the control panel is not used for activating the machine during production, but rather is used during routine maintenance checkups and changeovers. To activate the machines, the operator uses a single switch near the loading point. The last necessary modification is to make the machine accessible for cleaning from the front. Currently, the protective cage has doors on either side that are opened for daily cleaning which involves picking up the oil that falls off the tubes and

chips created during the forming process. One idea is to have a funnel-like device catch the waste, and channel it toward a reservoir in the front of the machine. In this way the reservoir can be quickly removed and replaced by a clean one, with cleaning taking place off-line by maintenance personnel.

For cell compatibility it would also be ideal for the forming machine to be placed on casters to allow various cell configurations to be continually tested with minimal effort. It also allows a machine requiring service to be easily taken out of the cell, and replaced by another machine with a minimum disruption to production. A summary of the changes to the current design is presented in Figure 5.6.

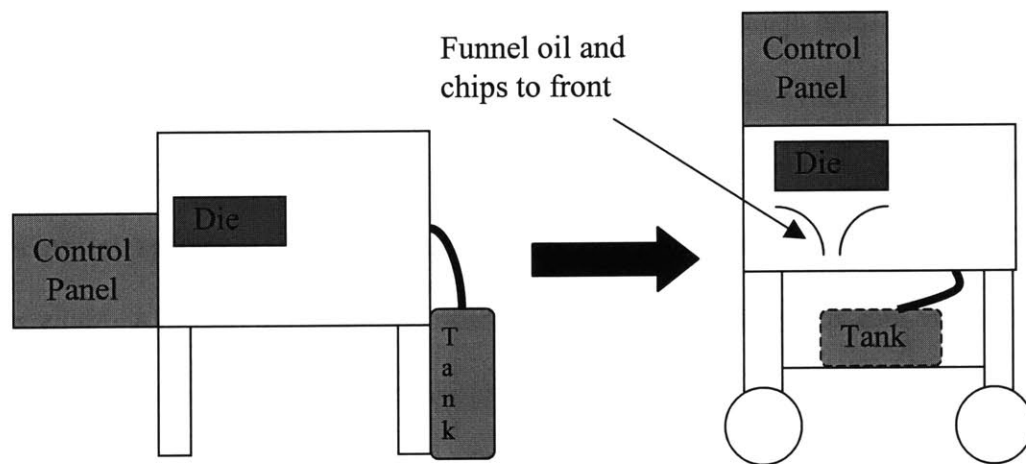

Figure 5.6: Suggested changes to the current forming machine design for the purpose of cell compatibility

As for the use of oil in the forming machines, it is assumed that the slower cycle time demands of the cell will translate into significantly less oil being needed. If the machines are designed for a cycle time on the order of 25 seconds¹, as opposed to 8 seconds, then it is feasible that less or no oil will be needed for the purposes of lubrication since the die move over the tube

at a slower speed. Similarly, the use of oil as a coolant is significantly reduced since the machine is used less frequently, and natural convection may be sufficient for cooling the dies. As in the case of the cutoff machine, the current oils being used should also be replaced with water-soluble ones. It is also important to determine the minimum amount of oil actually needed to ensure an acceptable formed end and prolong the life of the die. Once this amount is known, it is appropriate to eliminate the current method used for oil application – the operator dipping the end in a reservoir -- and instead applying a controlled amount of oil. Moreover, oil should only be applied at the required point. If these steps are taken, the task of washing may reduce to simply rinsing the ends of each tube and wiping them dry.

5.3.3 Brazing

The design of the current brazing machine makes it incapable of being used within a cell. First, the machine operates on a continuously rotating turntable, and does not detect whether a part has been loaded. In order to ensure that the machine is always loaded with a part, a worker is tied to this task. A second operator is used solely for unloading, and a third for inspecting the parts. In the cell, tying workers to the machine is not possible since workers are expected to be multifunctional and must leave machines unattended while completing the remainder of their workloop. In cell design, the focus shifts from getting maximum machine utilization to effectively utilizing the worker.

Besides requiring constant worker attention, the brazing machines also have unpredictable output in terms of quality. In a few instances, poorly brazed parts reach final assembly and are detected by the leak test. However, it is most common for the inspector at each braze machine to visually detect the majority of defective brazes, and feed the parts back into the machine. While

¹ A machine cycle time of 25 seconds was decided to allow for volume flexibility in the fabrication cells which are designed to run at takt times on the order of 30 – 45 seconds. Thus, the cell can accommodate increases in volume until takt time equals 25 seconds, at which time it becomes necessary to duplicate the cell.

it is good that the defective parts are not passed to the next operation, the fact that the parts are reworked without investigation of the root cause makes problems in brazing persistent.

However, it is the low process capability that ultimately ties a third worker to each brazing machine. In the cell, machines are expected to be both capable and reliable so that inspection can be avoided, or at least minimized.

The last feature of the current brazing machine that must be addressed by the new design concerns changeover time. The machine has twelve identical fixtures, one at each station, and changeover from one type of braze to another involves removing and replacing all twelve fixtures, and temperature and flame position changes to the three heating stations. While exchanging the fixtures is standard, and the quantity of fixtures is the only issue, in the case of setting heating parameters, changeover procedure becomes one of trial-and-error. On average, a changeover currently takes 15-20 minutes, and is not acceptable within the fabrication cells, which are designed to operating at takt times of 30-45 second.

In order to address the above problems, the newly designed braze machine will consist of only three stations: load/unload, heating, and cooling, and have an operator-controlled, indexing turntable. See Figure 5.7. The parts will not advance to the next station until the operator returns to unload the part loaded three cycles ago, loads a new part, and activates the machine with a walk-away switch. At this point, each of the parts would advance by one stage, so that the loaded part moves to the heating station, the heated part moves to be cooled and the cooled part unloads itself, ready for the operator. To accomplish this end, it is necessary that the flame at the heat station be capable of shutting off or withdrawing in the interval between completing the braze and waiting for the operator to return. This feature of removing the heat source is necessary since overheating also leads to an unacceptable braze. In order to program the

machine, it is necessary to have the heating time for each braze type – P-nut, saddle, stem adaptor, and charge valve—predetermined. The same programmable logic controller (PLC) will also keep records of specific adjustments such as duration for heating and cooling, flame temperature and the configuration of the burners. These parameters can be pre-set for all braze and part types to be run on the machine, in which case the task of changing over is reduced to the operator selecting from a menu containing numbers corresponding to each braze type. Using the PLC greatly reduces the effort required for changeover, and by having accounted for brazing in the formation of subset families, the frequency of changeover is also minimized.

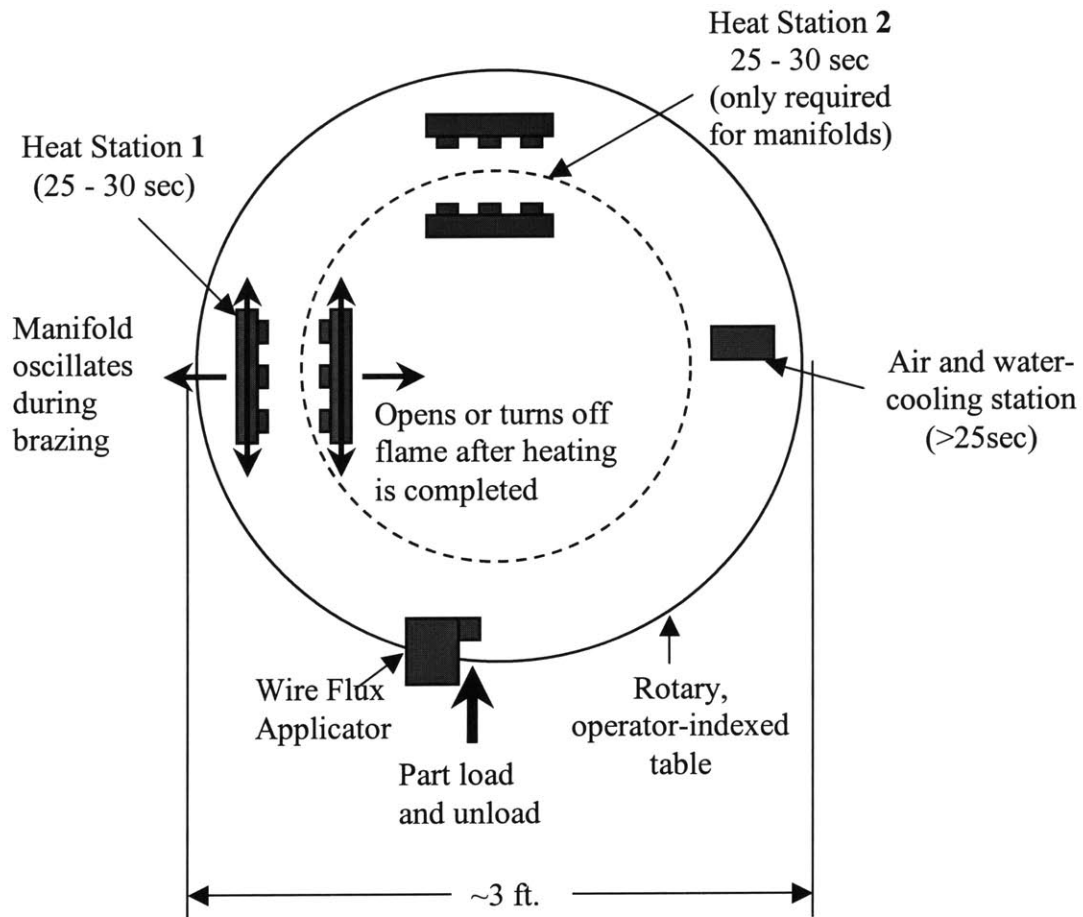

Figure 5.7: Conceptual design for a cellular brazing machine.

The new design is possible for use with all braze types with the exception of the manifold. Given that the manifold has significantly more mass than hollow tubes, it requires longer heating time. On the three station design being proposed, the manifold has a 75-80 seconds cycle time with about 45-50 seconds of that time being for heating. Thus, to meet takt time it will be necessary to subdivide heating into two stations on machines that will braze manifolds. The second heat station can easily be added as a module to the three-station design since cooling and load/unload stations remain unchanged.

5.3.4 Bending

In forming product families, consideration is not given to the bends required since both the number of bends and the required geometry of each bend varies greatly among models. The number of bends per tube ranges from 0 to 12. However, two tubes with an equal number of bends will not have a similar geometry since the position of the bends along the tube length can vary, as well as the angle of each bend. On current bending machines (see Figure 1.15) it is necessary to have a specific die designed for each bend required, and changing over a die can take up to 20 minutes. If these machines were to be used in a cell “as is,” it would be necessary for the number of machines to equal half of the aggregate number of bends per family. For example, if a family is composed of three end models, requiring a total number of 2, 5, and 6 bends respectively, then the cell will need at least 7 bending machines. This approach greatly increases the physical size of the cell. Another major flaw of the current machines is that where an odd number of bends are required an entire bending station sits completely idle. As in the above example, where the total number of bends is 13 and 7 bending machines are required. It is suggested that the current bending machines be completely replaced if they are to be used within the assembly cells.

The best candidate for use within a cell is a CNC bender, similar to those used in the prototype shop. In this way a single machine can bend any tube regardless of the number of bends or geometry required, and the need for dies is eliminated. However, unlike the prototype shop's CNC machines, it is necessary that the machines be capable of bending tubes with formed ends. The alternative, in which the tubes are bent immediately after being cut, results in complicated fixtures being required for brazing and makes forming and washing difficult. Bending should be postponed as long as possible since the handling of bent tubes may cause the desired geometry to be lost.

In order to make the CNC bender capable of handling formed tubes, it is necessary to change the mechanism used to rotate and index the tubes. On the CNC benders in the prototype shop, the tube is fed into a single jaw that rotates and indexes it, as well as holds it in place during bending. Feeding of the tube into the jaw is the characteristic of the current design that does not allow the tube to have formed ends since the jaw requires that the tube have a uniform outer diameter over its entire length. The current design is depicted in Figure 5.8.

In the new design, the tube would not actually be indexed, but rather a jaw would be able to move along the length of the tube dictating the location of the bend, while a stationary jaw would be used to rotate the part. Thus, the material would not feed into the stationary jaw as in the current design. Instead, the stationary jaw would be located to the side of the tube, and would be positioned at a convenient point along the length of the tube. In this arrangement, a tube with formed ends can be handled. The concept for the new design is shown in Figure 5.9.

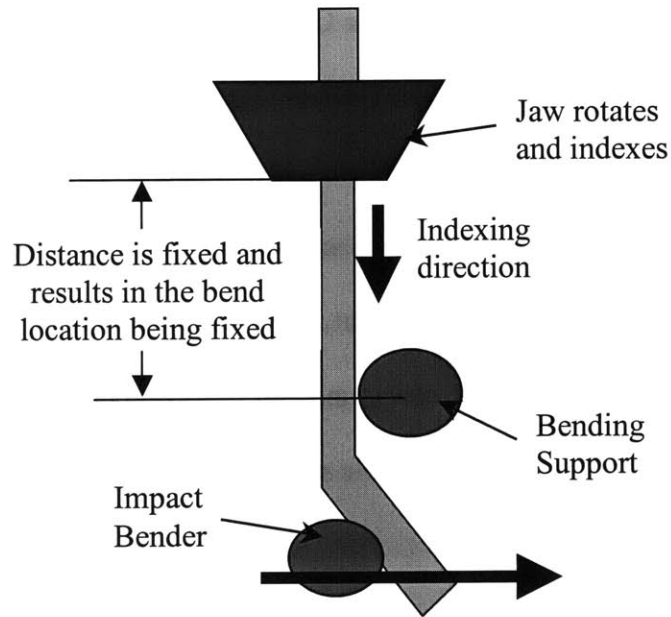

Figure 5.8: Current design couples the indexing and rotating functions into a single jaw, and therefore cannot accommodate formed tubes

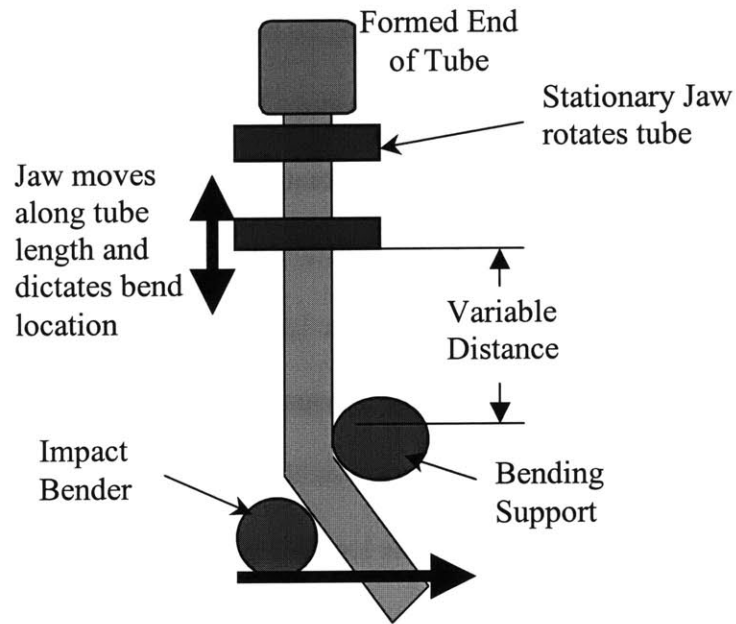

Figure 5.9: Proposed design for uncoupling rotation and indexing of the tube. Part is not linearly indexed, instead a jaw moves along the length to dictate bend location. Allows formed tubes to be bent.

5.3.5 Crimping

For the most part, the crimping machines can be used “as is” since the necessary modifications to this operation are being addressed through the design of new fixtures that allow multiple crimps to be made on a single machine. However, an improvement that could be pursued is replacing the two-palm activating switch with a single-touch switch. See Figure 5.10. The two-palm switch was implemented to avoid the injury that would result if the operator’s hand was in the way as the die came down. However, within the cell the operator would ideally be able to load the part and walk away from the machine to do the next task, and thus a single-touch switch is more appropriate. To maintain the same level of safety as the current design offers, a light curtain could be installed. If the sensor is activated by the operator’s hand breaking the light, then the machine can be programmed to shut off. As a second improvement, it is suggested that the crimping machines also be put on casters for reasons cited in the case of the forming machines.

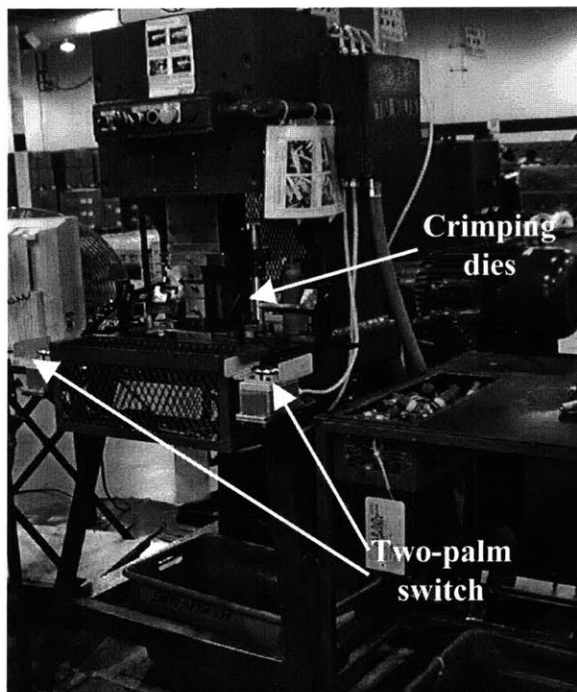

Figure 5.10: Crimping machine

5.3.6 Summary of Suggested Equipment Modifications

The answer to the question as to which equipment could be remain “as is”, which could be modified to fit the new system and which needed to be replaced, is summarized in Table 5.1, along with the suggested modifications for each piece of equipment.

Table 5.1: Equipment Modifications Required for Use in Cells

Machine	Recommendation	Desired Effect	Modification
Tube Cutoff Machine	Modify	No oil needed at roller a) reduce friction b) reduce contact length	Modify spool and roller a) change roller material b) change spool orientation with respect to roller
		No oil for indexing	Bottom jaw <u>not</u> in contact with stock in “open” position
		No oil at cutting blade	Replace with water-soluble coolant
Forming	Modify	Ease of loading machine	Adjust to proper height for walking worker
		Reduce width of machine front	Control panel and oil tank relocated
		Ease of mobility	Put machine on casters
		Minimize/eliminate the need for oil	Increase machine cycle time closer to takt time
		If oil is needed, then applied in controlled amounts	Water-soluble oil applied at point of use
Brazing	Replace	Operator controlled	Indexing turntable
		Reduce changeover time a) reduce number of fixtures b) standard process of changing heating parameters	a) Three station design b) Programmable Logic Controlled heaters
Bending	Replace	Bend tubes without need for die changeover	CNC benders
		Bend formed tubes with CNC machine	Uncoupled design for rotating and indexing
Crimping	Keep “as-is” (with minor modifications)	Separate worker from machine	Replace two-palm switch, with single-touch switch
		Ease of mobility	Put machine on casters

5.4 Conversion of Remaining Steel Tubes to Aluminum

Due to considerations including final vehicle weight and the extra plating processing required, all steel tubes and components are being redesigned of aluminum. It is anticipated that within the next few years all tubes will be aluminum, and thus investment in equipment for steel fabrication is not justifiable. While the ultimate goal is to eliminate steel, it is still necessary to put forth a strategy for the product development team to follow during the redesign of tubes and components. From the viewpoint of manufacturing system design, the conversion of the steel manifold to aluminum is critical and should be given high priority.

The manifold is the component that makes all “Hybrid, 4 crimp” models (for an example, refer back to Figure 4.2) dependent on steel. This family is the second largest and represents nearly 28% of the total volume. (Current “Aluminum, 4 crimp” models do not have manifolds, and the additional tube in their design is usually intended to give a specific geometry that is not achievable with a rubber hose) The strategy for linking cells within the “Hybrid, 4 crimp” family, calls for each assembly cell to be fed by three fabrication cells with one of the fabrication cells producing the manifold subassembly. However, as long as the manifold is made of steel it will continue to be fabricated in a departmental system. While the departmental system is capable of feeding the assembly cell, it does so at the expense of increased inventory since large batch sizes will be delivered to the cell. Moreover, the rate of information feedback between the assembly cell and the fabrication of the manifold is decreased. As a result, defects take longer to detect, and changes in the production schedule are more difficult to coordinate. By redesigning the manifold these problems are avoided, and the ideal manufacturing system can function as intended.

After conversion of the steel manifold, the product development team could continue to focus their efforts on redesigning steel components based on total volume represented by a

product family that makes use of steel tubes. Applying this strategy, the steel tubes would be converted in the following order:

1. all tubes of the Hybrid, 2 crimp family (11.3% of the total volume)
2. all tubes of the Hybrid, 6 crimp family (8.6% of the total volume)
3. all tubes of the Steel, 0 crimp family (3.8% of the total volume)
4. all tubes of the Steel, 2 crimp family (0.9% of the total volume)
5. all tubes of the Steel, 4 crimp family (0.4% of the total volume)
6. all tubes of the Steel, 6 crimp family (0.3% of the total volume)

With many of these models sharing similar type tubes and components, redesigns made for one product family will be applicable when redesigning the next. Thus, as the redesign process continues the time to convert the components of an entire family should shorten significantly.

Once all tubes are designed of aluminum, the number of product families is reduced from ten to four (Aluminum 0, 2, 4, and 6 families), and thus there will be much more uniformity within the manufacturing system. One advantage to achieving this uniformity is that improvements are more easily transferred throughout the organization. Similarly, it becomes easier for workers to move about the system, and makes the goal of volume flexibility, by adding and removing workers from the cells, a more feasible proposition. Yet another advantage of having fewer families is that the flexibility of assigning products to run in a specific cell is greatly increased. Thus, the complexity of each cell can be further reduced, as better combinations of products within a family become available.

5.5 Organize Personnel into Product Families Teams

In the current production system, the manufacturing engineering support group is broken down by vehicle type such that each engineer is responsible for a set of specific vehicles. The

method used for appointing certain engineers to a particular vehicle is not clear, but in any case there are three flaws to this structure. First, the products a single engineer is responsible for are scattered throughout the plant, making it difficult to be aware of the status of each. Second, with each vehicle type requiring very different hoses, the lessons learned from one hose may not even be applicable to another. Third, communication between engineers responsible for similar hoses, and thus similar production problems, is difficult to coordinate.

In order to avoid the above problems, it is suggested that engineering support be assigned to product families, making it easier to allocate personnel as needed. For example, in the current system it is not obvious how to

- assess the number of vehicle platforms each engineer should be responsible for, and
- whether the hoses for one vehicle require more time and attention than those of another.

In the new arrangement there is a basis for assuming that an “aluminum, 2 crimp” model which has no brazes is easier to fabricate and assemble, than an “aluminum, 6 crimp” with several brazes. Support can be supplied accordingly, and the engineers can be easily moved around as necessary. Beside complexity of the product family, engineers could also be allocated based on the volume each family comprises.

It is also suggested that current production personnel, in particular production supervisors, be grouped according to product families, rather than departments. In the current system there is a lack of communication among departments. Worse, the departmental arrangement persuades the local optimization of departments over optimization of overall system performance. Supervisors make decisions to improve measurables such as overhead, direct labor, scrap, and material cost in their individual department, without regard for the impact these

decisions have on other areas and the system as a whole. In the new arrangement, it is suggested that production supervisors be assigned to an assembly cell and the fabrication cells that feed it. In this way, the decisions being made take into consideration the entire manufacture of an end model, and the consequences of seeking a local saving are more evident.

5.6 Conclusions

The changes Coclisa must make are typical of any company undergoing conversion to a lean production system in that they require equipment design to be rethought, coordination with the product design team to improve manufacturing performance, and cultural change to deal with a different organizational structure. While the design of equipment and products are continuous tasks that take place whether converting production systems or not, changes to an organizational structure are less common.

It is foreseeable that the structure change may prove to be the largest hurdle of the conversion process. In the specific case of Coclisa, it will be difficult to have a supervisor who has only worked in assembly give equal attention to the fabrication cells for which he will come to assume responsibility. In a similar fashion, breaking the paradigm of having engineers assign to specific vehicle types, with no overlap, will force interdependence on one another and may also be a difficult transition. While the proposed organizational structure is not necessarily required for the manufacturing system to function as designed, the suggested changes are intended for the entire production system to run more smoothly. Thus, if it is truly the responsibility of all employees, other than direct workers, to provide support to the production of parts, then it is feasible that this task is simplified and better support is offered by having these functions kept in line with the design of the manufacturing system.

6 References

- [1] Black, *The Design of the Factory with a Future*, New York: McGraw-Hill, Inc, 1991. ISBN 0-07-005550-5
- [2] Black and Schroer, Simulation of an Apparel Assembly Cell With Walking Workers and Decouplers, *Journal of Manufacturing Systems*, Vol 12/No. 2, 1993, pp. 170-180
- [3] Cochran, Manufacturing System Design and Control, PhD Thesis, Department of Industrial Engineering, Auburn University, 1994.
- [4] Cochran, *Historical Comparison of Manufacturing Systems and Defining Waste*, Lecture from Production System Design Course, 1999.
- [5] Cochran, *Plant Design Comparison: Lean vs. Mass from a Production System Perspective*, Lecture from Production System Design Course, 1999.
- [6] Cochran, *Why are plants designed the way they are?*, Lecture from Production System Design Course, 1999.
- [7] Cochran, *Time in Manufacturing Systems*, Lecture from Production System Design Course, 1999.
- [8] Cochran, *Cell Design*, Lecture from Production System Design Course, 1999.
- [9] Cochran, *Steps to Lean*, Lecture from Production System Design Course, 1999.
- [10] Cochran, *Balanced Production*, Lecture from Production System Design Course, 1999.
- [11] Cochran and Dobbs, Mass vs. lean Plant Design Evaluation Using the Production System Design Decomposition, submitted to *Journal of Manufacturing Systems*, out for review.
- [12] Estrada, Shukla, and Cochran, Converting from Moving Assembly Lines to Cells, to be presented at CIRP Conference, Cambridge, MA: June 28-30, 2000.
- [13] Klein, The Human Costs of manufacturing Reform, *Harvard Business Review*, March-April 1989, pp. 4-8.
- [14] Linck and Cochran, The Importance of Takt Time in Manufacturing System Design, Proceeding from IAM/SAE Conference, Detroit, MI: May 11-13, 1999.
- [15] Maccoby, Is there a Best Way to Build a Car?, *Harvard Business Review*, November-December 1997, pp. 161-170.
- [16] Monden, *Toyota Production System: An Integrated Approach to Just-in-Time*, Norcross, GA: Engineering & Management Press, 1993. ISBN 0-89806-180-6
- [17] Ohno, *Toyota Production System*, Portland, OR: Productivity Press, 1988. ISBN 0-915299-14-3
- [18] Shingo, *A Study of the Toyota Production System*, Portland, OR: Productivity Press, 1989. ISBN 0-915299-17-8

- [19] Shukla, Estrada, and Cochran, Equipment Design in Fabrication as Part of Production System Design, to be presented at CIRP Conference, Cambridge, MA: June 28-30, 2000.
- [20] Spear and Bowen, Decoding the DNA of the Toyota Production System, Harvard Business Review, September-October 1999, pp. 97-106.
- [21] Suh, The Principles of Design, New York: Oxford University Press, 1990. ISBN 0-19-504345-6
- [22] Suh, Cochran, and Lima, Manufacturing System Design, Annals of 48th General Assembly of CIRP, 1998, Vol. 47/2/1998, pp. 627-639.
- [23] Wemmerlov and Johnson, Empirical findings on manufacturing cell design, International Journal of Production Research, 2000, Vol. 38, No. 3, pp. 481-507.
- [24] Womack and Jones, *Lean Thinking*, New York: Simon & Schuster, 1996. ISBN 0-684-81035-2
- [25] Womack, Jones, and Roos, *The Machine that Changed the World*, New York: HarperCollins Publisher, 1991. ISBN 0-06-097417-6

7 Appendices

7.1 Appendix A: Estimate of Direct Worker Requirements

Large Family	% of Total Volume	Takt Time	# of assy cells	# of direct workers per assy cell	total # of direct assy workers (2 shifts)	# of fab cells	# of direct workers per fab cell	total # of direct fab workers (2 shifts)	Total # of direct workers (2 shifts)
Family 1 - St, 0 crimp	3.8	39	1	3	6	0	0	0	6
Family 2 - Al, 2 crimp	35.6								
2A: 5/16, no Al braze		35	3	3	18	3	2	12	30
2B: 13/32, no Al braze		34	4	3	24	4	2	16	40
2C: 13/32 & 5/8, with 2 Al brazes		51	2	2	8	4	1	8	16
Family 3 - Hybrid, 2 crimp	11.3								
3A: 13/32, no Al braze		35	1	3	6	1	2	4	10
3B: 5/8, no Al braze		30	1	3	6	1	2	4	10
3C: 13/32 (& 5/8), with 3 Al brazes		64	1	2	4	1	1	2	6
Family 5 - Al, 4 crimp	9.9								
5A: 13/32,13/32, no braze		35 (1st shift)	0.5	3	3	1.5	2	6	9
5B: 5/8, 5/8, with 1 Al braze		47 (2nd shift)	0.5	3	3	1.5	1	3	6
5C: 13/32,13/32, with 1 Al braze		45	1	3	6	3	1	6	12
5D: misc diameters, max 4 brazes		47	1	3	6	3	2	12	18
Family 6 - Hybrid, 4 crimp	27.7								
6A: 13/32,5/8, no braze		32	2	3	12	2	2	8	20
6B: 13/32,5/8, with up to 3 Al brazes		39 (1st shift)							
6C: 5/16, 5/16 with up to 3 Al brazes		37 (2nd shift)	1	3	6	1	2	4	10
6D: 13/32, 3/4 with 1 Al braze		48	1	3	6	2	1	4	10
6E: 13/32, 3/4 with 2 Al braze		37	3	3	18	6	2	24	42
Totals	88.3		23	43	132	34	23	113	245
Family 9 - Hybrid, 6+ crimp	8.6	34	2	5	20	3	2	12	32
Family 8 - Al, 6 crimp	1.6	49 (1st shift)	1	4	8	4	2	16	24
Family 4 - St, 2 crimp	0.9								
Family 7 - St, 4 crimp	0.4	45 (2nd shift)							
Family 10 - St, 6 crimp	0.3								
Totals	100.1		26	52	160	41	27	141	301

7.2 Appendix B: Estimate of Equipment Requirements

Large Family	% of Total Volume	# of Al fab cells	# of leak test machines	# of crimping machines	# of CNC bending machines (for Al)	# of brazing machines (for Al)	# of 3 stroke forming machines (for Al)	# of 6 stroke forming machines (for Al)	# of ferrule grooving machines (for Al)	# of end cage grooving machines (for Al)	# of piercing machines (for Al)
Family 1 - St, 0 crimp	3.8	0	1	0	0	0	0	0	0	0	0
Family 2 - Al, 2 crimp	35.6										
2A: 5/16, no Al braze		3	3	6	6	0	6	3	3	3	0
2B: 13/32, no Al braze		4	4	8	8	0	8	4	4	4	0
2C: 13/32 & 5/8, with 2 Al brazes		4	2	4	4	2	8	4	4	2	2
Family 3 - Hybrid, 2 crimp	11.3										
3A: 13/32, no Al braze		1	1	2	2	0	2	1	1	1	0
3B: 5/8, no Al braze		1	1	2	2	0	2	1	1	1	0
3C: 13/32 (& 5/8), with 3 Al brazes		1	1	2	2	3	2	1	1	1	1
Family 5 - Al, 4 crimp	9.9										
5A: 13/32,13/32, no braze											
5B: 5/8, 5/8, with 1 Al braze		3	1	4	3	1	6	1	3	1	1
5C: 13/32,13/32, with 1 Al braze		3	1	4	3	1	6	2	3	1	0
5D: misc diameters		3	1	4	3	4	6	3	3	1	1
Family 6 - Hybrid, 4 crimp	27.7										
6A: 13/32,5/8, no braze		2	2	8	6	0	4	2	2	2	0
6B: 13/32,5/8, with up to 3 Al brazes											
6C: 5/16, 5/16 with up to 3 Al brazes		1	1	4	3	3	2	1	1	1	1
6D: 13/32, 3/4 with 1 Al braze		2	1	4	3	1	4	1	2	1	1
6E: 13/32, 3/4 with 2 Al braze		6	3	12	9	6	12	6	6	3	1
Totals	88.3	34	23	64	54	21	68	30	34	22	8
Family 9 - Hybrid, 6+ crimp	8.6	3	2	12	12	4	6	2	3	2	1
Family 8 - Al, 6 crimp	1.6	4	1	6	4	4	8	4	4	1	1
Family 4 - St, 2 crimp	0.9										
Family 7 - St, 4 crimp	0.4										
Family 10 - St, 6 crimp	0.3										
Totals	100.1	41	26	82	70	29	82	36	41	25	10

5967 - 21