

**Comparison of Analytical and Numerical Approaches for Determining Failure of Ring-Stiffened Cylindrical Shells**

by

**Michael W. Temme**

B.S. Electrical Engineering  
South Dakota State University, 1990

MBA

University of Nebraska-Lincoln, 1997

Submitted to the Department of Ocean Engineering and the Department of Mechanical Engineering in  
Partial Fulfillment of the Requirements for the Degrees of

Master of Science in Naval Architecture and Marine Engineering

and

Master of Science in Mechanical Engineering

at the

Massachusetts Institute of Technology

June 2003

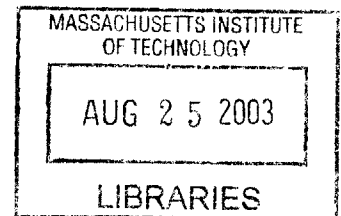

© 2003 Michael W. Temme. All rights reserved.

The author hereby grants to MIT permission to reproduce and to distribute publicly paper and electronic copies of this thesis document in whole or in part.

Signature of Author \_\_\_\_\_

Department of Ocean Engineering and the  
Department of Mechanical Engineering  
May 12, 2003

Certified by \_\_\_\_\_

A handwritten signature in black ink, appearing to be "D. Burke".

David V. Burke, Senior Lecturer  
Department of Ocean Engineering  
Thesis Supervisor

Certified by \_\_\_\_\_

Nicholas M. Patrikalakis, Professor of Ocean and Mechanical Engineering  
awasaki Professor of Engineering  
Thesis Reader

Accepted by \_\_\_\_\_

A handwritten signature in black ink, appearing to be "Michael Triantafyllou".

Michael Triantafyllou, Professor of Ocean Engineering  
Chairman, Department Committee on Graduate Students  
Department of Ocean Engineering

Accepted by \_\_\_\_\_

Ain A. Sonin, Professor of Mechanical Engineering  
Chairman, Department Committee on Graduate Students  
Department of Mechanical Engineering

**BARKER**

Page Intentionally Left Blank

**Comparison of Analytical and Numerical Approaches for Determining Failure of Ring-Stiffened Cylindrical Shells**

by

Michael W. Temme

Submitted to the Department of Ocean Engineering and the Department of Mechanical Engineering in Partial Fulfillment of the Requirements for the Degrees of

Master of Science in Naval Architecture and Marine Engineering  
and

Master of Science in Mechanical Engineering

**ABSTRACT**

The thesis compares the analytical solution, two marine classification society design rules, and numerical analysis against experimental results for predicting the failure modes (general instability, axisymmetric buckling, and asymmetric collapse of the shell) and failure pressures of ring-stiffened cylindrical shells.

The analytical solution is first summarized based on several sources. Design rules for the classification societies are then presented with brief explanations for each one. The design rules used are: American Petroleum Institute (*Bulletin on Stability Design of Cylindrical Shells*, API Bulletin 2U, Second Edition, October 2000) and Det Norske Veritas (*Buckling Strength of Shells*, October 2002). The numerical analysis was performed using the software package, Method For Analysis Evaluation and Structural Optimization (MAESTRO™, version 8.5, Proteus Engineering).

The United States Navy Naval Sea Systems Command, Submarine Structural Integrity Division supplied experimental data for four test cylinders that covered the failure modes and allowed comparison between experimental and analytical / numerical results.

The comparison of experimental to predicted data found the design rules and numerical solution performed adequately in predicting asymmetric buckling and general instability failure modes, but the predictions for failure pressure were unsatisfactory. The design rules were overly conservative in their predictions of failure pressure due to the semi-empirical solutions used in the rules. The numerical solution was only slightly better for the same failure pressure predictions. The results indicate the predicted failure pressure for a cylinder is closely tied to the size and dimensions of the cylinders used for determining the empirical solutions. These results should be further explored to determine causes and corrections.

Thesis Supervisor: David V. Burke

Title: Senior Lecturer

Thesis Reader: Nicholas M. Patrikalakis

Title: Professor of Ocean and Mechanical Engineering

Kawasaki Professor of Engineering

## Acknowledgements

I would like to thank Mr. William Will of the Naval Sea Systems Command, Submarine Structural Integrity division for providing the experimental data for the thesis and providing invaluable knowledge into the mechanics of cylindrical failures.

I would like to thank Prof. Owen Hughes of the Aerospace and Ocean Engineering Department, Virginia Tech for providing me with information and advice on MAESTRO™ and the source code behind the program.

I would also like to thank Dr. David Burke for not only being a very supportive advisor and providing the impetus for the thesis, but for giving much needed and timely guidance throughout the analysis and writing processes.

This thesis is dedicated to:

My wife: Holly A. Temme

My parents: Lowell G. Temme and Ethel A. Temme

# Table of Contents

Table of Contents .....	5
List of Figures .....	8
List of Tables .....	8
CHAPTER 1: Introduction and Problem Statement .....	9
1.1 Definition of Failure Modes.....	9
1.2 Literature Search.....	10
1.3 Previous Work .....	11
1.4 Problem Statement .....	12
CHAPTER 2: Approach .....	13
2.1 Analysis Techniques .....	13
2.1.1 Analytical Methods.....	13
2.1.2 Numerical Method .....	14
2.2 Design Rules Examined.....	14
CHAPTER 3: Basics of Ring-Stiffened Cylindrical Shells.....	15
3.1 Nomenclature.....	15
3.2 Dimensions .....	15
3.3 Stresses in Cylinders .....	17
CHAPTER 4: Analytic Solution.....	19
4.1 Axisymmetric Yield.....	20
4.2 Asymmetric Buckling.....	24
4.3 General Instability.....	25
CHAPTER 5: Numerical Solution.....	27

5.1 MAESTRO™ Overview.....	28
5.2 Cylindrical Models.....	29
5.3 Failure Modes Evaluated .....	29
CHAPTER 6: Classification Society Design Rules.....	31
6.1 American Petroleum Institute (API).....	31
6.1.1 Limitations and Applicability .....	32
6.1.2 Local Shell Buckling.....	32
6.1.3 General Instability.....	34
6.2 Det Norske Veritas (DNV) .....	35
6.2.1 Limitations and Applicability .....	36
6.2.2 Shell Buckling.....	36
6.2.3 Panel Ring Buckling .....	38
CHAPTER 7: Results .....	41
7.1 NAVSEA Test Cylinders.....	41
7.1.1 Cylinder 1.d.....	42
7.1.2 Cylinder 1.f .....	43
7.1.3 Cylinder 2.a.....	44
7.1.4 Cylinder 2.c.....	45
7.2 Calculation to Experimental Comparison.....	46
7.2.1 Cylinder 1.d Results.....	46
7.2.2 Cylinder 1.f Results .....	48
7.2.3 Cylinder 2.a Results .....	50
7.2.4 Cylinder 2.c Results .....	51

7.3 Comparison to Previous Work.....	53
CHAPTER 8: Conclusions .....	55
8.1 Comparative Analysis Review.....	55
8.2 Agreements and Discrepancies .....	56
8.3 Applications of the Results .....	58
8.4 Further Areas of Study.....	59
List of References .....	61
Appendices.....	63
Appendix A: Analytic Solution .....	65
Appendix B: Numerical Solution.....	91
Appendix C: API (Bull 2U) Solution.....	123
Appendix D: DNV (RP-C202) Solution.....	165

## List of Figures

Figure 1: General Cylinder Dimensions .....	16
Figure 2: General Stiffener Dimensions .....	17
Figure 3: Failure Pressure Ratio versus Slenderness Ratio .....	20
Figure 4: Element of a Cylindrical Shell .....	21
Figure 5: Test Cylinder 1.d Structural Dimensions .....	42
Figure 6: Test Cylinder 1.f Structural Dimensions.....	43
Figure 7: Test Cylinder 2.a Structural Dimensions .....	44
Figure 8: Test Cylinder 2.c Structural Dimensions .....	45
Figure 9: Comparison of Predicted Failure Pressures for Cylinder 1.d.....	47
Figure 10: Comparison of Predicted Failure Pressures for Cylinder 1.f.....	49
Figure 11: Comparison of Predicted Failure Pressures for Cylinder 2.a.....	50
Figure 12: Comparison of Predicted Failure Pressures for Cylinder 2.c.....	52

## List of Tables

Table 1: Comparison of Predicted Failure Mode and Pressure to Experimental Data .....	46
Table 2: Predicted Failure Pressures and Modes for Cylinder 1.d .....	47
Table 3: Predicted Failure Pressures and Modes for Cylinder 1.f.....	48
Table 4: Predicted Failure Pressures and Modes for Cylinder 2.a.....	50
Table 5: Predicted Failure Pressures and Modes for Cylinder 2.c.....	51
Table 6: Comparison With Previous Work.....	53



# CHAPTER 1: Introduction and Problem Statement

Recent interest in submersibles, submarines, and off-shore drilling rigs, has led to an increasing demand for structural design information on ring-stiffened cylindrical shells under uniform external pressure. The submarine designer today, has many analytical tools and methods available to help determine an optimum design. The widespread use of ring-stiffened cylinders in the marine industry has resulted in a significant amount of interest and activity being devoted to determining the failure pressure and characteristics of these cylinders. Marine Classification Societies, such as the American Petroleum Institute (API), the American Bureau of Shipping (ABS), Det Norske Veritas (DNV), Germanischer Lloyd (GL) and others have promulgated design rules to provide guidelines on designing and building stiffened cylinders for marine use. Other research has been conducted using numerical methods, such as finite element analysis, to design and validate the structural adequacy of these ring-stiffened cylinders. By comparing these design methods, classification society design rules and numerical methods, with experimental results, the submarine designer can obtain a better understanding of the strengths and limitations of each method.

## 1.1 Definition of Failure Modes

Any discussion of cylinder failure analysis must first include definitions of the different failure modes. There are primarily three failure modes for ring-stiffened cylinders. They are axisymmetric yielding (AX) of the shell between stiffeners, asymmetric buckling of the shell between stiffeners (Lobar buckling) (L), and general instability (GI) of the shell and stiffeners. Axisymmetric yield is characterized by an accordion type pleat extending around the periphery of the cylinder, and generally occurs when the shell is relatively heavy and the frames are closely

spaced. Lobar buckling is characterized by inward and outward lobes or dimples, which may or may not develop around the entire periphery, and normally occurs when the shell is relatively thin and the frames are strong and widely spaced. General instability is characterized by the failure of both the shell and ring frames resulting in a dished-in surface. General instability normally occurs when the cylinder is relatively long, the shell is thin, and the frames are light.

## **1.2 Literature Search**

The failure of cylinders exposed to external pressure has been studied for over a hundred years. As early as the 1850's, attempts were made to understand cylinder behavior by using experiments and empirical relationships [1]. The first analytic solution for a non-reinforced cylinder was presented by G. H. Bryan in 1888 [2]. During this time period, non-reinforced flues were observed to fail in fire-tube boilers at a pressure much less than the hoop stress, which led to a significant amount of research and interest in the subject. As a solution to this problem, stiffening rings or bulkheads were added to reduce the unsupported length of the tube [3]. The first analysis of a reinforced cylinder appeared in 1913 by R. V. Southwell, followed a year later by a solution to the elastic buckling of a thin shell proposed by von Mises [1]. In 1934 Widenburg proposed a solution for asymmetric buckling that was independent of the number of lobes of failure, which made the solution easier to calculate [1]. Solutions for axisymmetric yield were first put forward by von Sanden and Günther in 1920 [2]. In 1930, Viterbo presented a modified version of Sanden and Günther's solution [2]. Finally, Pulos and Salerno incorporated the previous work and presented a solution that included the Sanden and Günther solution, the Viterbo modification and a term to account for the bending stress in the cylinder caused by the axial pressure [2]. For elastic general instability, the first reported analysis was

presented by Tokugawa in 1929. In 1954 A. R. Bryant developed a similar equation using a different methodology [1].

Analytical work from the 1950's onward has focused on obtaining solutions for different boundary conditions and more fully reconciling the analytic predictions with experimental results and more fully understanding the effects of initial cylinder imperfections. With the advent of the digital computer, programs like BOSOR 5 were developed that could use numerical solutions to quickly and accurately predict failure pressures [1]. Further developments relating to numerical solutions led to the design of finite element programs, like ABAQUAS™, that could provide accurate stress and strain values for analyzing cylinder designs [1].

### **1.3 Previous Work**

Tighter budgets in both industry and government have forced many large organizations to look for cost saving measures. One such perceived cost saving measure has been the outsourcing of many functions that were previously done within an organization. An example of this is found in the greater role that marine classification societies are playing in certifying and classifying naval vessels, not only for commercial interests, but also for governments. This interest has led many classification societies to develop extensive rules for certifying naval vessels and other marine structures. These rules can also be valuable tools for the submarine designer.

In a recent review of these classification society rules, D.J. Price used two marine classification design rules and compared them with analytical and experimental results for ring-stiffened cylinders [4]. His work indicated that the two rules used (ABS and GL) were accurate for predicting axisymmetric yielding and lobar buckling when compared to experimental results.

However, they did not accurately predict failure by general instability. Further study was indicated in this area.

## **1.4 Problem Statement**

In today's fiscally constrained environment, the submarine designer is faced with the challenge of providing the best structural design possible at the lowest cost. Detailed confirmation models can increase costs not only through expensive fabrication but also time delays for constructing and testing the models. If the designer can use some of the tools available, like classification society design rules and numerical solutions, to reduce or eliminate some of the confirmation models, there are significant cost savings to be anticipated.

This thesis used three of the design tools available (classification society design rules, numerical analysis tools, closed-form analytic solutions) to determine the failure modes and pressures for four experimentally tested ring-stiffened cylinders. The results from the design tools and the experiments were compared to determine the applicability and usefulness of these tools.

This thesis was not an exhaustive study of classification rules or of numerical analysis tools, rather it was an application of the design tools available. Comparisons and conclusions were drawn based on the results in order to provide the submarine designer a better understanding of the limitations of each design method.

## **CHAPTER 2: Approach**

For this thesis, emphasis was placed on exploring how various classification society design rules predicted failure of cylinders that were similar in design to modern submarine hulls. Similar design meant that the shell was relatively thick compared to the diameter of the cylinder. For comparison purposes, a numerical analysis was also performed on the same cylinders using a numerical analysis tool. In order to compare results with previous work, experimental failure data was obtained from the Naval Sea Systems Command (NAVSEA) Submarine Structural Integrity Division on the same test cylinders used in [4]. For consistency of analysis, the scope was limited to examining ring-stiffened cylindrical shells. The test cylinders used were selected to cover all three modes of cylinder failure, allowing for comparison of not only failure pressure but also failure mode.

### **2.1 Analysis Techniques**

#### **2.1.1 Analytical Methods**

For the purpose of this thesis, the analytical methods include the classification society design rules and the closed-form analytic solutions. These analytical methods were programmed into MATHCAD™ for consistency of approach, clarity of symbolic representation, and ease of calculation. Dimensions were input into each computer code, which provided failure pressures for each mode of failure. The lowest calculated pressure was considered the failure pressure with a corresponding failure mode. The failure modes and pressures were compared to experimental results with primary emphasis being placed on agreement of failure mode and secondary emphasis on failure pressure.

### **2.1.2 Numerical Method**

To determine a numerical solution for the failure mode and pressure of a ring-stiffened cylinder, a numerical analysis tool was used. Analysis was performed using the Method for Analysis Evaluation and Structural Optimization (MAESTRO™), version 8.5 distributed by Proteus Engineering. Models of the test cylinders were created in MAESTRO™ and subjected to increasing submergence pressure until failure occurred. The associated failure mode and pressure were considered the failure point for the model. Once again, failure modes and pressures were compared to experimental results with primary emphasis being placed on agreement of failure mode and secondary emphasis on failure pressure.

### **2.2 Design Rules Examined**

There were two classification society design rules examined: The American Petroleum Institute (Bulletin on Stability Design of Cylindrical Shells, API (Bull 2U), Second Edition, October 2000) [5] and Det Norske Veritas (Recommended Practice on Buckling Strength of Shells, DNV-RP-C202, October 2002) [6]. The specific classification societies were selected due to their widespread use throughout the world and the availability of documented rules for ring-stiffened cylinders. Additionally, API was selected because of its widespread use in the U.S. while DNV was selected because of its widespread use in Europe. By using these two classification societies, a concise snapshot of guidance relating to cylinder design could be obtained for a large segment of the marine industry.

## **CHAPTER 3: Basics of Ring-Stiffened Cylindrical Shells**

The main structural body of most submarines and submersibles today, is constructed of a cylindrical parallel mid-body section. These cylinders are reinforced with ring-stiffeners (frames) to provide additional strength to the shell that would collapse very easily if not reinforced. A strong cylindrical structure is required for the large pressure differential between external hydrostatic pressure and internal pressure (normally maintained close to atmospheric pressure).

### **3.1 Nomenclature**

Each of the analytical and numerical methods incorporated in this study used slightly different terminology for cylinder geometries and properties. When the analytical methods were programmed into MATHCAD™, the symbols used by the source document were generally used in the program to avoid confusion between the published classification society rules and the programs. All of the analytical methods required the calculation of the moment of inertia of a combined plate and stiffener ( $I_c$ ) using an effective shell length ( $L_e$ ). The formula for  $I_c$  came from [7], while the formulas for  $L_e$  were normally contained within the classification society rules. All stresses and pressures are in pounds per square inch (psi), lengths are in inches (in), areas are in square inches ( $\text{in}^2$ ) and moments of inertia are in inches to the fourth ( $\text{in}^4$ ).

### **3.2 Dimensions**

The dimensions of interest for analyzing ring-stiffened cylinders are related to the cylinder (shell) itself and the ring-stiffeners (frames). Terms and definitions are listed below and represented in Figure 1 and Figure 2.

- 1) Cylinder Length ( $L_b$ ): Overall length of the cylinder between supports.
- 2) Radius of Cylinder ( $R$ ): Mean shell radius.
- 3) Shell Thickness ( $t, h$ ): Thickness of cylinder shell plating.
- 4) Ring Spacing ( $L_f$  or  $L_r$ ): Unsupported length of shell from centerline to centerline of frames.
- 5) Web Height ( $h_w$ ): Length of the web from shell to the shell side of flange.
- 6) Web Thickness ( $t_w$ ): Thickness measured across web.
- 7) Flange Breadth ( $b_f$ ): Width of the flange.
- 8) Flange Thickness ( $t_f$ ): Thickness of flange measured perpendicular to breadth.
- 9) Faying Width ( $b$ ): Contact width of ring frame to shell, normally equal to  $t_w$ .
- 10) Effective Shell Length ( $L_e$ ): Usually some fraction of  $L_f$  specified in the individual solution.
- 11) Area of Stiffener ( $A_f$  or  $A_r$ ): Cross-sectional area of the ring-stiffener.
- 12) Effective Area of Stiffener ( $A_{eff}$  or  $A_T$ ): Cross-sectional area of combined stiffener and  $L_e$  of shell.

**Figure 1: General Cylinder Dimensions**

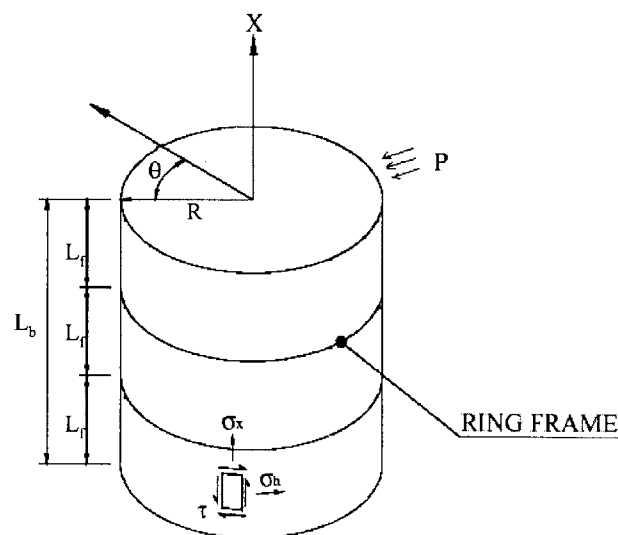



**Figure 2: General Stiffener Dimensions**

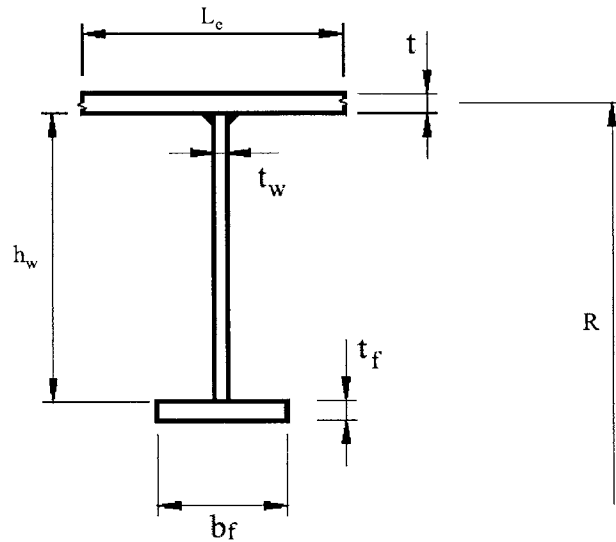

### 3.3 Stresses in Cylinders

Stresses in cylindrical pressure vessels must be discussed briefly in order to provide a background for the derivation of the analytical solution. To begin with, a cylinder can be considered a thin-walled shell if the ratio of the radius,  $R$ , to shell thickness,  $t$ , is greater than ten. With this assumption, the determination of the stresses can be accomplished using statics alone. All of the cylinders under consideration for this thesis are treated as shells. Another assumption in the analysis is that hydrostatic pressure is considered constant across the shell.

From classic static analysis it can be shown that cylindrical shells, exposed to hydrostatic pressure, have two basic stresses imparted to them by the pressure: hoop stress and axial stress [8]. The equations for these stresses are shown below:

1) Hoop Stress:  $\sigma_h = \frac{pR}{t}$  (1)

2) Axial Stress:  $\sigma_x = \frac{pR}{2t}$  (2)

Where p is defined as the external (or internal) pressure, R is the mean shell radius and t is the thickness of the shell.

Once the shell is stiffened using ring-frames, the hoop stress analysis becomes complicated because non-uniform deformation of the shell is introduced in the radial direction. Additionally, there is a beam-column effect due to the pressure acting in the axial direction. The effects introduced by adding ring-frames are discussed in detail in Chapter 4.

## CHAPTER 4: Analytic Solution

While all failure modes are addressed individually, there was no comprehensive theoretical solution that addressed all modes. Reference [1] provides a good summary of the current closed-form analytic solutions that are widely used.

When trying to determine how a cylinder will fail, it is often advantageous to look at some key parameters. A first indicator of the failure mode of a cylinder is found by plotting the cylinder's slenderness ratio ( $\lambda$ ) against the pressure factor ( $\psi$ ) [9].  $\lambda$  has the following nondimensional value.

$$\lambda = \left[ \frac{\frac{L_f}{2R} \left( \frac{\sigma_y}{E} \right)}{\left( \frac{t}{2R} \right)^2} \right]^{\frac{1}{2}} \quad (3)$$

$\psi$  is the ratio of the shell buckling pressure ( $p_c$ ) to the hoop pressure at yield ( $p_y$ ).

$$\psi = \frac{p_c}{p_y} \quad (4)$$

For most steel cylinders, the following assumptions can be made;  $\nu=0.3$  and  $L_f/2R \gg t/2R$ . By making these assumptions the equation for  $\psi$  becomes [9]:

$$\psi = \frac{1.30}{\lambda^2} \quad (5)$$

A plot of  $\psi$  verses  $\lambda$  is shown in Figure 3.

**Figure 3: Failure Pressure Ratio versus Slenderness Ratio**

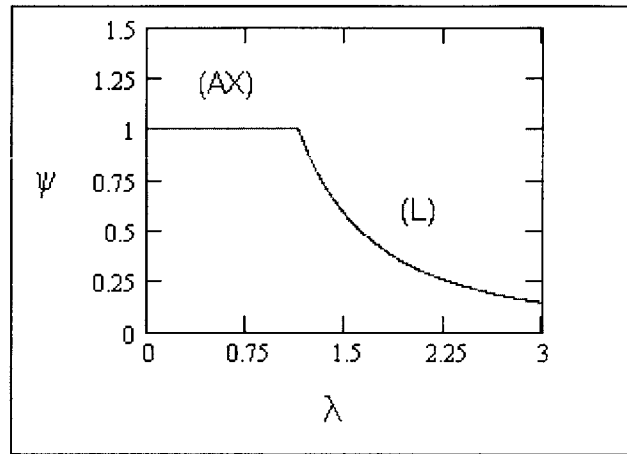

If the slenderness ratio is less than roughly 1.14 then the cylinder should fail by axisymmetric yield (AX), and when it is greater than 1.14 it should fail by lobar buckling (L). If the shell and stiffeners are not sufficiently sized, the cylinder may fail by general instability at a pressure less than that predicted by the  $\psi$  versus  $\lambda$  curve.

Another very important factor for the analytic solutions is the treatment of boundary conditions. The literature devotes a significant amount of research and discussion on what types of boundary conditions to use for analysis, with methods ranging from fully clamped to simply supported ends. In reality, both extremes are difficult to create, so the experimental results fall in a range between the two extremes. For this thesis, no discrete boundary conditions were required as inputs to the equations because the analytic solutions used do not distinguish between differing boundary conditions.

#### **4.1 Axisymmetric Yield**

Axisymmetric yield has been studied since the 1920's. As discussed in Chapter 1.2, Pulos and Salerno presented a closed-form solution for axisymmetric yield in 1961. It

incorporated previous works of van Sunden and Günther, and Viterbo and includes a previously neglected beam-column effect due to hydrostatic pressure acting in the axial direction of the cylinder [10]. The governing differential equation for the Pulos and Slerno equation is:

$$D \left( \frac{d^4 w}{dx^4} \right) + \frac{p \cdot R}{2} \cdot \frac{d^2 w}{dx^2} + \frac{E \cdot t}{R^2} \cdot w = p \cdot \left( 1 - \frac{\nu}{2} \right) \quad (6)$$

Where  $w$  is the radial displacement and  $D$  is the flexural rigidity of the shell and is defined:

$$D := \frac{E \cdot t^3}{12 \cdot (1 - \nu^2)} \quad (7)$$

The beam-column effect term is  $\frac{pR}{2}$  which makes equation (6) a non-linear function of pressure. This term was neglected in the previous analyses of axisymmetric yield and greatly improved the accuracy of the results. For deriving the governing equations, a coordinate system for a shell element is used in reference [10] and is shown in Figure 4.

**Figure 4: Element of a Cylindrical Shell**

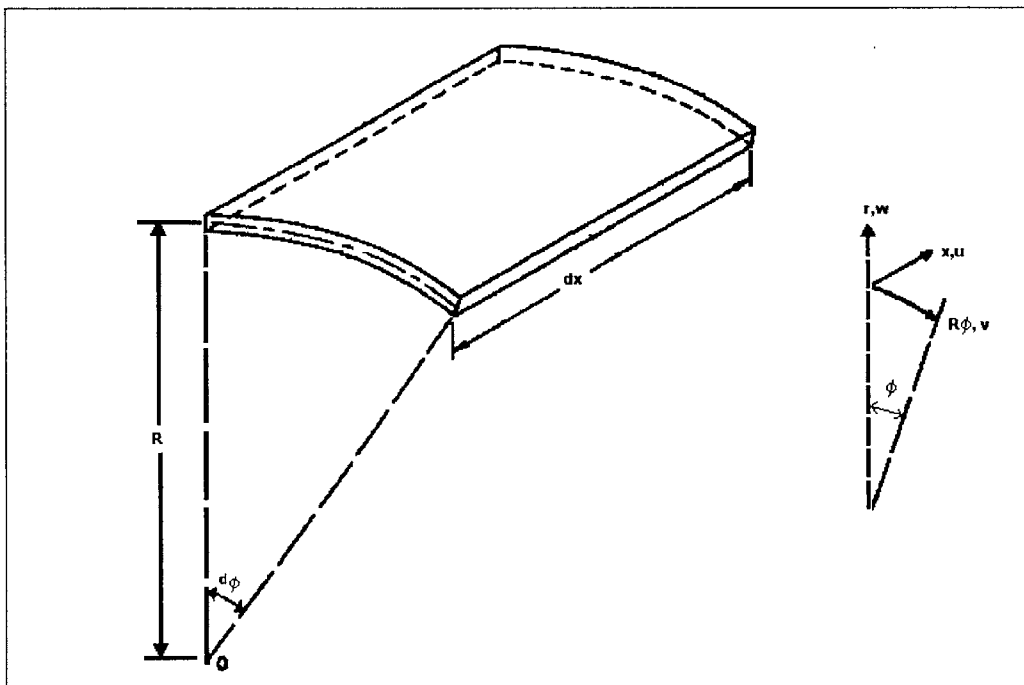

In order to solve the non-homogeneous differential equation, the general solution of the governing equation was written as the sum of the solution of the homogeneous equation and a particular solution [1]. The solution to the homogeneous equation produces four roots ( $\lambda_1, \lambda_2, \lambda_3, \lambda_4$ ). By analysis, placement of the origin of the coordinate system to take advantage of symmetry, and trigonometric identities, the general solution can be written as:

$$w = B \cosh \lambda_1 x + F \cosh \lambda_3 x - \frac{pR^2}{Et} \left(1 - \frac{\nu}{2}\right) \quad (8)$$

where B and F are new arbitrary constants of integration [10]. After further mathematical substitutions, several dimensionless parameters were introduced into the solution to allow ease of solving the problem. Four of these dimensionless parameters ( $F_1, F_2, F_3, F_4$ ) were transcendental functions based on the geometry of the cylinder. Poulos and Salerno graphed these transcendental functions in reference [10] to allow a quick solution to be found for a cylinder with known dimensions. Finally, an equation for the failure pressure of the cylinder was determined. The Poulos and Salerno equation is used in this analysis and is shown below:

$$P_{cAX} := \frac{\sigma_y \left(\frac{h}{R}\right)}{\sqrt{\frac{3}{4} + \kappa_1 - \kappa_2}} \quad (9)$$

Where:

$$\kappa_1 := A^2 \left[ F_2^2 + F_2 \cdot F_4 \cdot (1 - 2\nu) \cdot \left(\sqrt{\frac{0.91}{1 - \nu^2}}\right) + F_4^2 \cdot (1 - \nu + \nu^2) \cdot \left(\frac{0.91}{1 - \nu^2}\right) \right]$$

$$\kappa_2 := \left(\frac{3}{2}\right) \cdot A \cdot \left( F_2 - \nu \cdot F_4 \cdot \sqrt{\frac{0.91}{1 - \nu^2}} \right)$$

$$\beta := \frac{b}{L_f}$$

$$\alpha := \frac{A_{\text{eff}}}{L_f \cdot h}$$

$$A := \frac{\left(1 - \frac{v}{2}\right) \cdot \alpha}{\alpha + \beta + (1 - \beta) \cdot F_1}$$

$$\gamma := \frac{p_c}{2 \cdot E} \cdot \left[ \sqrt{3 \cdot (1 - v^2)} \right] \cdot \left( \frac{R}{h} \right)^2$$

$$\eta_1 := \frac{1}{2} \cdot \sqrt{1 - \gamma}$$

$$\eta_2 := \frac{1}{2} \cdot \sqrt{1 + \gamma}$$

$$\theta := \sqrt[4]{3 \cdot (1 - v^2)} \cdot \frac{L}{\sqrt{R \cdot h}}$$

$$F_1 := \frac{4}{\theta} \cdot \frac{\cosh(\eta_1 \cdot \theta)^2 - \cos(\eta_2 \cdot \theta)^2}{\frac{\cosh(\eta_1 \cdot \theta) \cdot \sinh(\eta_1 \cdot \theta)}{\eta_1} + \frac{\cos(\eta_2 \cdot \theta) \cdot \sin(\eta_2 \cdot \theta)}{\eta_2}}$$

$$F_2 := \frac{\frac{\cosh(\eta_1 \cdot \theta) \cdot \sin(\eta_2 \cdot \theta)}{\eta_2} + \frac{\sinh(\eta_1 \cdot \theta) \cdot \cos(\eta_2 \cdot \theta)}{\eta_1}}{\frac{\cosh(\eta_1 \cdot \theta) \cdot \sinh(\eta_1 \cdot \theta)}{\eta_1} + \frac{\cos(\eta_2 \cdot \theta) \cdot \sin(\eta_2 \cdot \theta)}{\eta_2}}$$

$$F_4 := \sqrt{\frac{3}{1 - v^2}} \cdot \frac{\frac{\cosh(\eta_1 \cdot \theta) \cdot \sin(\eta_2 \cdot \theta)}{\eta_2} - \frac{\sinh(\eta_1 \cdot \theta) \cdot \cos(\eta_2 \cdot \theta)}{\eta_1}}{\frac{\cosh(\eta_1 \cdot \theta) \cdot \sinh(\eta_1 \cdot \theta)}{\eta_1} + \frac{\cos(\eta_2 \cdot \theta) \cdot \sin(\eta_2 \cdot \theta)}{\eta_2}}$$

Once the variables were defined, an iterative process was required for the general case where the parameter  $\gamma$  was not zero. Iteration was begun by assuming  $\gamma$  was zero, and then finding the corresponding failure pressure. Having this interim failure pressure,  $\gamma$  was recalculated solving

the equations for failure pressure again. Usually only two or three iterations are needed for satisfactory convergence of the failure pressure [10].

## 4.2 Asymmetric Buckling

Asymmetric buckling, or lobar buckling, is the collapse of the shell between adjacent rings characterized by circumferential lobes extending partially around the periphery of the cylinder. As discussed previously, this failure mode normally occurs when the slenderness ratio ( $\lambda$ ) is greater than 1.14. Asymmetric buckling can also occur when the cylinder shell is relatively thin and the ring-stiffeners are widely spaced. In 1929, von Mises first proposed a solution to the buckling of non-reinforced cylinders under hydrostatic pressure. He assumed sinusoidal displacements in the axial and circumferential directions to allow solving a set of linearized partial differential equations. The equations represented the elastic action of the shell [1]. von Mises eventually obtained the following well know equation for the buckling pressure:

$$P_{vm} = \left( \frac{E \cdot t}{R} \right) \cdot \left[ \frac{1}{n^2 + .5 \cdot \left( \frac{\pi \cdot R}{L} \right)^2} \right] \cdot \left[ \frac{\left( \frac{\pi \cdot R}{L} \right)^4}{\left[ n^2 + \left( \frac{\pi \cdot R}{L} \right)^2 \right]^2} + \frac{\left( \frac{t}{R} \right)^2}{12 \cdot (1 - \mu^2)} \cdot \left[ n^2 + \left( \frac{\pi \cdot R}{L} \right)^2 \right]^2 \right] \quad (10)$$

Where L is the unsupported shell length between ring-frames ( $L = L_f - b$ ). In this equation, the buckling pressure is dependent on the number of circumferential lobes (n), which is an integer value. To arrive at the correct failure pressure, an iterative process is required varying n until the lowest pressure is determined.

Another approach to minimizing the failure pressure in equation (10) is to solve it analytically, and thus find an expression for failure pressure that is independent of n. In 1933, Widenburg solved this equation that resulted in the Widenburg approximation shown below [1]:



$$P_{cLB} := \frac{2.42 \cdot E \cdot \left(\frac{h}{D}\right)^{\frac{5}{2}}}{(1 - \nu^2)^{\frac{3}{4}} \cdot \left[ \left(\frac{L}{D}\right) - 0.45 \left(\frac{h}{D}\right)^{\frac{1}{2}} \right]} \quad (11)$$

Test data shows that buckling pressures determined by the use of equation (11) differ by no more than about 3.5 percent from those found from equation (10) [1]. Because of its ease of calculation and good results, the Widenburg approximation (11) is generally accepted in the reference material as the best method to calculate asymmetric buckling, and was therefore used for this analysis.

### 4.3 General Instability

General instability is characterized by the failure of both the shell and the ring-stiffeners. A cylinder normally fails by general instability when the rings are relatively “light” or “weak” in comparison to the shell, and the cylinder is long [1]. General instability can initiate in either the elastic or inelastic stress region, but the final configuration is in the plastic range of the material. Elastic general instability is the mode covered by the available literature and is addressed in this thesis. Inelastic general instability has been studied mainly by government laboratories and organizations. Most of the material is classified in nature and therefore not covered in this analysis.

The first analysis of general instability was conducted by Tokugawa in 1929 [1]. His methodology was based on the method of “split rigidities”, where he considered the failure of the ring and shell separately and summed the combined pressures [2]. In the 1940’s Kendrick used a strain energy method, with good results, to determine the failure pressure. Kendrick’s solution was rather complicated though, and in 1954 Bryant used a simpler strain energy method and

developed an equation that produced nearly the same results [2]. The Bryant equation is used in this analysis and is shown below:

$$p_{cGI}^{(n)} := \frac{Eh}{R} \left[ \frac{\lambda^4}{\left(n^2 + \frac{\lambda^2}{2} - 1\right) \cdot \left(n^2 + \lambda^2\right)^2} \right] + \frac{\left(n^2 - 1\right) \cdot EI_e}{R^3 \cdot L_f} \quad (12)$$

Where:

$$\lambda := \frac{\pi R}{L_b}$$

In the Bryant equation (12), the first term corresponds to the shell failure and the second term to the ring failure, similar to the “split rigidity” used by Tokugawa [2]. The moment of inertia ( $I_e$ ) used is that of the combined section of one ring plus an “effective” length ( $L_e$ ) of the adjacent shell. This effective length term has received significant attention over the years. For the purpose of this analysis,  $L_e$  was calculated using the equation from Pulos and Salerno shown below [10]:

$$L_e := 1.56\sqrt{R \cdot h} \cdot \left( \frac{\cosh(\theta) - \cos(\theta)}{\sinh(\theta) + \sin(\theta)} \right) \quad (13)$$

Where:

$$\theta := \sqrt[4]{3 \cdot (1 - \nu^2)} \cdot \frac{L}{\sqrt{R \cdot h}}$$

In order to determine the failure pressure for general instability (equation 12), the number of circumferential lobes ( $n$ ) must be varied to find the number that minimizes the failure pressure.

The calculations and results of the analytic solutions are provided in Appendix A.

## **CHAPTER 5: Numerical Solution**

Numerical analysis methods are very widely used in engineering design, and are employed extensively in the analysis of solids, structures, and fluids. With the advent of the digital computer, the effectiveness and general applicability of this form of engineering analysis was finally made practical. The tools available for numerical analyses cover a wide range of applicability from providing good first-order design predictions to detailed stress analyses. With the increasing fidelity of the numerical analysis tool, the cost of use (time and money) also increases. Some numerical analysis tools are good for initial design estimates and predictions, allowing the designer to easily input data and test several model variations. Other numerical analysis tools involve finite element analysis and provide detailed local stress evaluation of structures, but involve complicated models that are time consuming to develop and analyze. The submarine designer must consider the benefits and applicability of the various numerical analysis tools and determine which one is appropriate for the particular stage of the design process.

For this thesis, a numerical analysis tool was used for comparison to the analytic and classification society solutions for the failure pressure and failure mode of the test cylinders. As a result, the numerical analysis tool was selected based on its ease of use and applicability for cylindrical structures. The tool was intended to be used for initial design predictions and not local stress analysis. This thesis was not intended to make comparisons of different numerical analysis tools, rather to select one tool and compare it to other solutions using different methodology.

## 5.1 MAESTRO™ Overview

The Method for Analysis, Evaluation, and Structural Optimization (MAESTRO™) is a finite element-based computer analysis tool, designed specifically to facilitate the modeling of ocean engineering structures, including ships and ring-reinforced cylinders. MAESTRO™ was selected as the tool for determining the numerical solution and has the following features:

- 1) *Rationally-based* analysis tool, in that it is based on the limit-state approach to structural design as described in reference [7].
- 2) Capable of modeling virtually an entire structure; for a pressure hull of a submarine, this includes the hull plating, frames, kingframes, and bulkheads to almost any level of detail.
- 3) Capable of modeling virtually any load or combination of loads.
- 4) Can be operated in analysis, evaluation, or optimization modes.

The program's underlying theory and detailed description of its principal features are given in reference [7], which constitutes the Theoretical Manual for the program.

The basic units of structural modeling are principal ship structural members such as beams, stiffened panels, or girders. In order to have an efficient interaction for the finite element analysis, the elements used by MAESTRO™ are in most cases the same as the principal ship structural members [11]. Elements are combined to make strakes that are further grouped into modules. A module is a portion of the structure being modeled that has regularly spaced sections and local element dimensions that are similar; that is, plate thickness and flange and web widths and thicknesses. Modules are then combined together to create the complete mathematical model. The mathematical model is meshed using several finite element types discussed in detail in reference [11]. MAESTRO™ uses an interactive graphics program, MAESTRO™ Modeler,

to facilitate the creation of the structural model and the input file for analysis by the source program.

## 5.2 Cylindrical Models

MAESTRO™ is particularly useful for the submarine designer due to its ability to analyze cylindrical structures. Strakes can be identified as part of a complete cylinder (360 degrees) with the curvature (segment height, H) being defined at the strake level by the following equation:

$$H := R \left( 1 - \cos \left( \frac{\Theta}{2} \right) \right) \quad (14)$$

Where:

$\Theta$  is the strake's sector angle

When the cylinder option is used, it implies that the module includes one complete cylinder (or half cylinder) and that all of the strakes are part of that cylinder. For strakes identified in this manner, calculations are made to determine the proximity to failure modes similar to those defined in Chapter 1.1

For this thesis, cylindrical models were developed for the test cylinders with known dimensions and failure modes and pressures. The MAESTRO™ Modeler was used to graphically create the models (and input file), while the MAESTRO™ (version 8.5) solver was used to perform the numerical analysis.

## 5.3 Failure Modes Evaluated

MAESTRO™ uses limit states (or adequacy parameters) for determining proximity to failure for various structural members. When using the cylinder feature in MAESTRO™,

specific calculations are invoked which replace some of the limit state analyses with three types of cylinder collapse: bay buckling, general buckling, and local buckling. Calculations for these cylinder failure modes are based on API (Bull 2U, 1987 edition). A detailed discussion of API (Bull 2U) is provided Chapter 6.

The failure mode and pressure for each test cylinder was determined by varying the submergence pressure (load) applied to each model. Once one of the limit states was exceeded, the pressure was recorded as the failure pressure along with the corresponding failure mode. Results of the numerical analysis conducted using MAESTRO™ are provided in Appendix B.

## CHAPTER 6: Classification Society Design Rules

The two classification society design rules that were utilized were the American Petroleum Institute and Det Norske Veritas. These rules were chosen for their availability, their widespread use around the world, and their coverage of the specific geometries of the experimental cylinders. Additionally, API and DNV use semi-empirical formulations that could be contrasted to design rules that use strictly closed-form analytical equations.

### 6.1 American Petroleum Institute (API)

The API design rules, as delineated in the *Bulletin on Stability Design of Cylindrical Shells* [5], gives a brief and conservative approach for determining the failure pressures and stresses for each of the failure modes considered. Since the API design rules are used for many different types of marine structures, it accounts for several different stiffener and stringer geometries. The appropriate geometry for use in submarine design is classified as a “ring-stiffener” geometry. Under the ring-stiffener geometry, API (Bull 2U) addresses the following buckling modes: Local Shell Buckling, General Instability, Local Stiffener Buckling, and Column Buckling. For comparison purposes, local shell buckling and general instability described in [5] are the same as asymmetric buckling and general instability described in Chapter 1.1, respectively. Column buckling is of concern for large risers used to support axial loads while local stiffener buckling is of concern for designs with “light” stiffeners. Because column buckling and local stiffener buckling are not of concern for cylinders of the overall size and dimensions used in this analysis, these buckling modes were not considered.

The buckling strength formulations presented in this bulletin are based upon classical linear theory that is modified by reduction factors to account for the effects of imperfections,

boundary conditions, nonlinear material properties and residual stresses. The reduction factors are determined from empirical data on shells of representative size and initial imperfections [5].

**6.1.1 Limitations and Applicability**

API (Bull 2U) contains semi-empirical formulations for evaluating the buckling strength of stiffened cylindrical shells. The empirical data for these formulations was obtained through numerous tests of ring-stiffened cylindrical shells. As a result, the failure modes and pressures predicted are very dependent upon having cylinders similar in size to those used for the empirical data.

API (Bull 2U) is applicable to shells that are fabricated from steel plates where the plates are cold or hot formed and joined by welding, and stiffeners are to be uniformly spaced. It is intended for design and review of large diameter cylindrical shells, typically identified as those with diameter to shell thickness (D/t) ratios greater than 300 but less than 2000. A minimum shell thickness of 3/16 inches is allowed with a limit of shell radius to shell thickness (R/t) ratio of less than or equal to 1000. Most of the material used for empirical tests had yield strengths between 36 ksi and 100 ksi [5].

**6.1.2 Local Shell Buckling**

The failure pressure for local buckling mode (asymmetric buckling) was determined by first solving for the theoretical failure pressure for local buckling ( $p_{cL}$ ) of the cylindrical shell. Once the theoretical failure pressure was known, reduction factors were applied that account for fabrication tolerances ( $\alpha_{\theta L}$ ) and plasticity reduction ( $\eta$ ) for nonstress relieved shells [5]. The equation for determining the failure pressure for local buckling mode is shown below:

$$P_{cLr} := \eta \cdot \alpha_{\theta L} \cdot P_{eL} \tag{15}$$



The theoretical failure pressure formulation was based on an equation that was derived from von Mises equation (10). The theoretical failure pressure is a smooth lower bound curve of (10) which was obtained by letting the number of circumferential lobes ( $n$ ) be a noninteger [5]. The equations for the theoretical failure pressure are shown below:

$$p_{eL} := \begin{cases} \left[ \frac{5.08}{A_m^{1.18} + 0.5} \cdot E \cdot \left( \frac{t}{D} \right)^2 \right] & \text{if } M_x > 1.5 \wedge A_m < 2.5 \\ \left[ \frac{3.68}{A_m} \cdot E \cdot \left( \frac{t}{D} \right)^2 \right] & \text{if } 2.5 \leq A_m < 0.104 \cdot \left( \frac{D}{t} \right) \\ \left[ 6.688 \cdot C_p^{-1.061} \cdot E \cdot \left( \frac{t}{D} \right)^3 \right] & \text{if } 0.208 < C_p < 2.85 \\ \left[ 2.2 \cdot E \cdot \left( \frac{t}{D} \right)^3 \right] & \text{if } C_p \geq 2.85 \end{cases} \quad (16)$$

Where:

$$M_x := \frac{L_r}{\sqrt{R \cdot t}}$$

$$A_m := M_x - 1.17 + 1.06k$$

$$C_p := \frac{(2A_m)}{\left( \frac{D}{t} \right)}$$

$$k \equiv 0.5 \quad \text{for external hydrostatic pressure}$$

Imperfection factors ( $\alpha_{\theta L}$ ) are generally assigned a constant value of 0.8 for fabrication processes that meet the specifications given in [5]. The plasticity reduction factors are applied using the following equations:

$$\eta := \begin{cases} 1 & \text{if } \Delta c \leq 0.55 \\ \left( \frac{0.45}{\Delta c} + 0.18 \right) & \text{if } 0.55 < \Delta c \leq 1.6 \\ \frac{1.31}{1 + 1.15 \cdot \Delta c} & \text{if } 1.6 < \Delta c < 6.25 \\ \frac{1}{\Delta c} & \text{if } \Delta c \geq 6.25 \end{cases} \quad (17)$$

Where:

$$\Delta c := \frac{F_{reLr}}{F_y}$$

$F_y$  = yield strength of the material

$F_{reLr}$  = elastic buckling stress

### 6.1.3 General Instability

The failure pressure for general instability mode was calculated by first determining the theoretical elastic failure pressure for general instability ( $p_{eG}$ ) of the ring-stiffened shell. Once the elastic failure pressure was determined, reduction factors were applied that account for fabrication tolerances ( $\alpha_{\theta G}$ ) and plasticity reduction ( $\eta$ ) for nonstress relieved shells, in a manner similar to Chapter 6.1.2. The equation for determining the failure pressure for general instability mode is shown below:

$$p_{cGr} := \eta \cdot \alpha_{\theta G} \cdot p_{eG}^{(n)} \quad (18)$$

The theoretical failure pressure formulation was based on the Bryant equation (12), where the failure pressure was a function of the number of circumferential lobes ( $n$ ), which must be varied to determine the minimum pressure value. The equation for the theoretical failure pressure is shown below:

$$p_{eG^{(n)}} := \frac{E \cdot \left(\frac{t}{R}\right) \cdot \lambda_G^4}{\left(n^2 + k \cdot \lambda_G^2 - 1\right) \cdot \left(n^2 + \lambda_G^2\right)^2} + \frac{E \cdot I_{er} \cdot (n^2 - 1)}{L_r \cdot R_c^2 \cdot R_o} \quad (19)$$

Where:

$$\lambda_G := \frac{\pi R}{L_b}$$

$$I_{er} := I_r + A_r \cdot Z_r^2 \cdot \frac{L_e \cdot t}{A_r + L_e \cdot t} + \frac{L_e \cdot t^3}{12} \quad \text{moment of inertia calculation}$$

$$L_e := \begin{cases} (1.1\sqrt{D} \cdot t + t_w) & \text{if } M_x > 1.56 \\ L_r & \text{if } M_x \leq 1.56 \end{cases} \quad \text{effective length determination}$$

$R_c$  = radius to the centroid of the effective section

$R_o$  = radius to the outside of the shell

The imperfection factor ( $\alpha_{0G}$ ) and the plasticity reduction factor ( $\eta$ ) are the same as those applied in Chapter 6.1.2.

The results and calculations of the API (Bull 2U) analysis are provided in Appendix C.

## 6.2 Det Norske Veritas (DNV)

The DNV design rules, as delineated in the *Buckling Strength of Shells*, Recommended Practice DNV-RP-C202 [6], treats the buckling stability of shell structures based on the load and resistance factor design format (LRFD). The methods used in [6] are considered semi-empirical. The reason for basing the design on semi-empirical methods is that the agreement between theoretical and experimental buckling loads for some cases has been found to be non-existent. This discrepancy is due to the effect of the geometric imperfections and residual stresses in fabricated structures. Actual geometric imperfections and residual stresses do not in general

appear as explicit parameters in the expressions for buckling resistance. This means that the methods for buckling analysis are based on an assumed level of imperfections. For DNV, this tolerance level is specified in DNV OS-C401; *Fabrication and Testing of Offshore Structures*. Since the DNV design rules are used for many different types of marine structures, they account for several different stiffener and stringer geometries. The appropriate geometry for use in submarine design is classified as a “ring-stiffened” geometry. Under the ring-stiffened geometry, DNV (RP-C202) addresses the following buckling modes: Shell Buckling, Panel Ring Buckling, and Column Buckling. For comparison purposes, shell buckling and panel ring buckling described in [6] are the same as asymmetric buckling and general instability described in Chapter 1.1, respectively. Column buckling is of concern for large risers used to support axial loads. Because column buckling is not of concern for cylinders of the overall size and dimensions used in this analysis, this buckling mode was not considered.

### **6.2.1 Limitations and Applicability**

Similar to API (Bull 2U), DNV (RP-C202) contains semi-empirical formulations for evaluating the buckling strength of stiffened cylindrical shells. In the case of the DNV design rules though, no specific limitations were placed on the size or dimensions of the cylinders. The only specified requirement, assumes the edges of the cylinder are effectively supported by ring frames, bulkheads or end closures [6]. Neither empirical data nor experimental results, used to derive the equations for cylinder buckling were provided in [6].

### **6.2.2 Shell Buckling**

The failure pressure for shell buckling (asymmetric buckling) was determined by first calculating the characteristic buckling strength of the shell ( $f_{ks}$ ). The characteristic buckling

strength was then divided by a material factor ( $\gamma_M$ ) to determine the design shell buckling strength ( $f_{ksd}$ ) shown below:

$$f_{ksd} := \frac{f_{ks}}{\gamma_m} \quad (20)$$

Where:

$$f_{ks} := \frac{F_y}{\sqrt{1 + \lambda_{s\_square}^2}}$$

$$\gamma_m := \left[ \begin{array}{l} 1.15 \text{ if } \lambda_s < 0.5 \\ (0.85 + 0.6\lambda_s) \text{ if } 0.5 \leq \lambda_s \leq 1.0 \\ 1.45 \text{ if } \lambda_s > 1.0 \end{array} \right]$$

To solve (20), the reduced shell slenderness ( $\lambda_s$ ) must first be defined.  $\lambda_s$  is a combination of the shell stresses and elastic buckling strength. For the current analysis, the design stresses associated with bending and shear were neglected since they were not present in the test cylinders analyzed. The equation for reduced shell slenderness is shown below:

$$\lambda_{s\_square} := \frac{F_y}{\sigma_{j\_sd}} \cdot \left( \frac{-\sigma_{a\_sd}}{f_{Ea}} + \frac{-\sigma_{h\_sd}}{f_{Eh}} \right) \quad (21)$$

Where:

$$\sigma_{j\_sd} := \left( \sigma_{a\_sd}^2 - \sigma_{a\_sd} \cdot \sigma_{h\_sd} + \sigma_{h\_sd}^2 \right)^{\frac{1}{2}} \quad \text{design equivalent von Mises stress}$$

$$\sigma_{a\_sd} := \frac{-\text{press} \cdot R}{2t} \quad \text{design axial stress}$$

$$\sigma_{h\_sd} := \frac{-\text{press} \cdot R}{t} \cdot \left[ 1 - \frac{\alpha \cdot \left( 1 - \frac{\nu}{2} \right) \cdot \xi_{t\_m}}{\alpha + 1} \right] \quad \text{design circumferential stress}$$

$$f_E := \frac{C_{SB} \cdot \pi^2 \cdot E}{12 \cdot (1 - \nu^2)} \cdot \left( \frac{t}{L_r} \right)^2$$

elastic buckling strength of shell

$$C_{SB} := \psi \cdot \sqrt{1 + \left( \frac{\rho \cdot \xi}{\psi} \right)^2}$$

reduced buckling coefficient

The remaining constants and definitions are provided in [6].

Using the above equations, the design shell buckling strength ( $f_{ksd}$ ) can be determined for a specific submergence pressure. The shell buckling strength was then compared to the design equivalent von Mises stress ( $\sigma_{j\_sd}$ ). If  $\sigma_{j\_sd} \leq f_{ksd}$  then the cylinder should not fail by shell buckling. To determine the pressure at which the shell would fail,  $\sigma_{j\_sd} > f_{ksd}$ , an iterative process was used. Submergence pressure was increased in step intervals while recalculating (20) and (21). Once the limit condition was exceeded, a failure pressure for shell buckling was determined.

### 6.2.3 Panel Ring Buckling

Failure by panel ring buckling (general instability) was determined by evaluating both the cross sectional area of a ring frame and the effective moment of inertia of a ring frame. To ensure the ring frame would not fail prematurely the cross sectional area of a ring frame (exclusive of the effective shell plate flange) should not be less than  $A_{Req}$ , defined by:

$$A_{Req} \geq \left( \frac{2}{Z_L^2} + 0.06 \right) \cdot L_r \cdot t$$

(22)

Where:

$$Z_L := \frac{L_b^2}{R \cdot t} \cdot \sqrt{1 - \nu^2}$$

If a ring-stiffened cylinder, or a part of a ring-stiffened cylinder, is effectively supported at the ends, a *refined calculation of moment of inertia* ( $I_h$ ) is used by DNV (RP-C202) for calculating the capacity of the ring frame. Using an initial geometry, an effective moment of inertia of the combined ring frame and shell ( $I_e$ ) can be calculated. The value for  $I_e$  is also implicit in the procedure for calculating the buckling capacity of the panel and ring.

When a ring-stiffened cylinder is subjected to external pressure, the ring-stiffeners should satisfy:

$$p_{sd\_GI} \leq 0.75 \frac{f_k}{\gamma_m} \cdot t \cdot r \cdot f_r \frac{\left(1 + \frac{A_r}{I_{eo} \cdot t}\right)}{R^2 \cdot \left(1 - \frac{\nu}{2}\right)} \quad (23)$$

Where:

$$f_k := (f_r) \cdot \frac{1 + \mu + \lambda_1^2 - \sqrt{(1 + \mu + \lambda_1^2)^2 - 4 \cdot \lambda_1^2}}{2 \cdot \lambda_1^2} \quad \text{characteristic buckling strength}$$

$f_r$  = characteristic material yield strength ( $F_y$ )

$$\lambda_1 := \sqrt{\frac{f_r}{f_E}} \quad \text{reduced column slenderness}$$

$$\mu := \frac{Z_t \cdot \zeta_o \cdot r \cdot f_r \cdot L_r}{i_{h\_square} \cdot R \cdot I_{eo}} \cdot \left(1 - \frac{C_2}{C_1}\right) \cdot \frac{1}{1 - \frac{\nu}{2}}$$

$$C_1 := \frac{2 \cdot (1 + \alpha_B)}{1 + \alpha} \cdot \left( \sqrt{1 + \frac{0.27 \cdot Z_L}{\sqrt{1 + \alpha_B}}} - \frac{\alpha_B}{1 + \alpha_B} \right)$$

$$C_2 := 2 \cdot \sqrt{1 + 0.27 \cdot Z_L}$$

$$\alpha_B := \frac{12 \cdot (1 - \nu^2) \cdot I_h}{L_r \cdot t^3}$$

$$i_{h\_square} := \frac{I_h}{A_r + l_{eo} \cdot t} \quad \text{effective radius of gyration or ring frame}$$

$$l_{eo\_min} := \begin{pmatrix} 1.56\sqrt{R \cdot t} \\ L_r \end{pmatrix} \quad \text{equivalent length of shell plating}$$

$$\zeta_o := 0.005R \quad \text{initial out-of-roundness parameter}$$

$$I_h := I_e \quad \text{effective moment of inertia}$$

$$Z_L := \frac{L_b^2}{R \cdot t} \cdot \sqrt{1 - \nu^2} \quad \text{curvature parameter}$$

$A_r$  = cross-sectional area of ring frame

$r_f$  = radius of shell measured to ring flange

Using the above equations, the maximum design external pressure can be determined.

Given known cylinder and ring frame dimensions, values can be substituted in equation (23) and the associated calculations to determine a maximum design external pressure. The maximum design pressure is then considered the failure pressure for the panel ring failure (general instability) mode.

The results and calculations of the DNV (RP-C202) analysis are provided in Appendix D.



## **CHAPTER 7: Results**

The analytic solution, numerical solution, and classification society design solution were all compared against test data collected from experiments conducted by the United States Navy in support of submarine design. Each solution method was used to determine a failure pressure and failure mode for each of the test cylinders. The resulting predictions were then compared to the experimental results. Of primary interest was the agreement between the predicted and experimental mode of failure, followed by the accuracy of the predicted failure pressure when compared to the actual failure pressure.

### **7.1 NAVSEA Test Cylinders**

The test data was provided by the Naval Sea Systems Command Submarine Structural Integrity Division (NAVSEA 05P2). Data was provided for four test cylinders that were selected to cover the range of examined failure modes. The cylinder diameter to thickness ratios ( $D/t$ ) were from 112 to 198. Two of the cylinders had internal stiffeners while the other two cylinders had external stiffeners. All four test cylinders had built-up end stiffeners with a combination of narrower spacing and / or larger stiffener dimensions than the uniform section of stiffeners. The end stiffeners were designed to prevent shell yielding in the end bays due to increased stress levels associated with the boundary conditions. It was estimated that without the end stiffeners a 4-5% reduction in axisymmetric yielding pressure could occur [12]. Neither the analytic solution nor the classification society design rules allowed for variable spaced stiffeners, therefore the non-uniformities were disregarded and the end stiffeners were treated as uniform section stiffeners. The four test cylinders are described below.

### 7.1.1 Cylinder 1.d

Cylinder 1.d was a machined cylindrical shell with external rectangular stiffeners. The material used was high strength steel with yield strength of 80,000 psi. Figure 5 shows the structure and principal dimensions of the cylinder. The boundary conditions consisted of one end being fully fixed with the other end having all freedoms fixed except for axial displacement. External hydrostatic pressure was applied including axial line load to simulate load on the end plate. The experiment tested the ability of the analysis method to predict elastic shell buckling (asymmetric buckling). The experimentally determined collapse pressure was 633 psi with failure by asymmetric (Lobar) buckling.

**Figure 5: Test Cylinder 1.d Structural Dimensions**

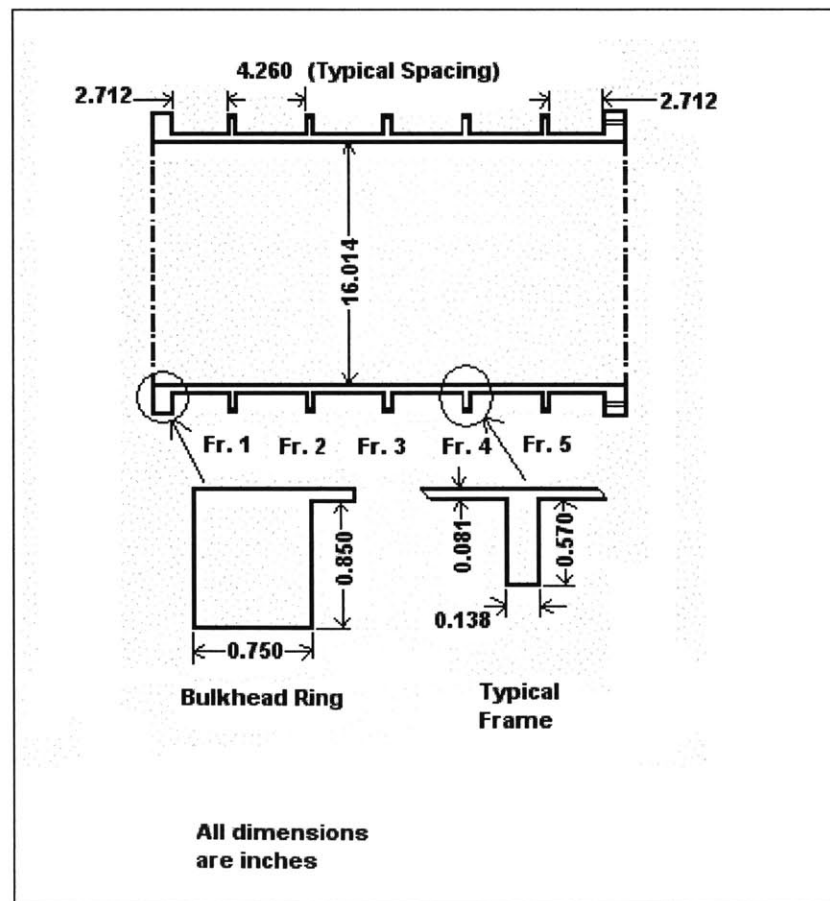

### 7.1.2 Cylinder 1.f

Cylinder 1.f was a cylindrical shell with internal tee stiffeners of welded construction. The material used was high strength steel with yield strength of 98,500 psi. The boundary conditions consisted of 4.0 inch steel plates attached with full fixity to the end of the adaptor ring on the model. External hydrostatic pressure was applied. This test cylinder was used to predict failure by elastic general instability. There was no experimental elastic collapse pressure; therefore the critical pressure was calculated by two separate, reliable analysis programs with the results being 4858 psi (with 3 waves) and 4953 psi (with 3 waves). The test cylinder actually failed by inelastic general instability at a pressure of 2200 psi. Figure 6 shows the structure and dimensions of the test cylinder.

**Figure 6: Test Cylinder 1.f Structural Dimensions**

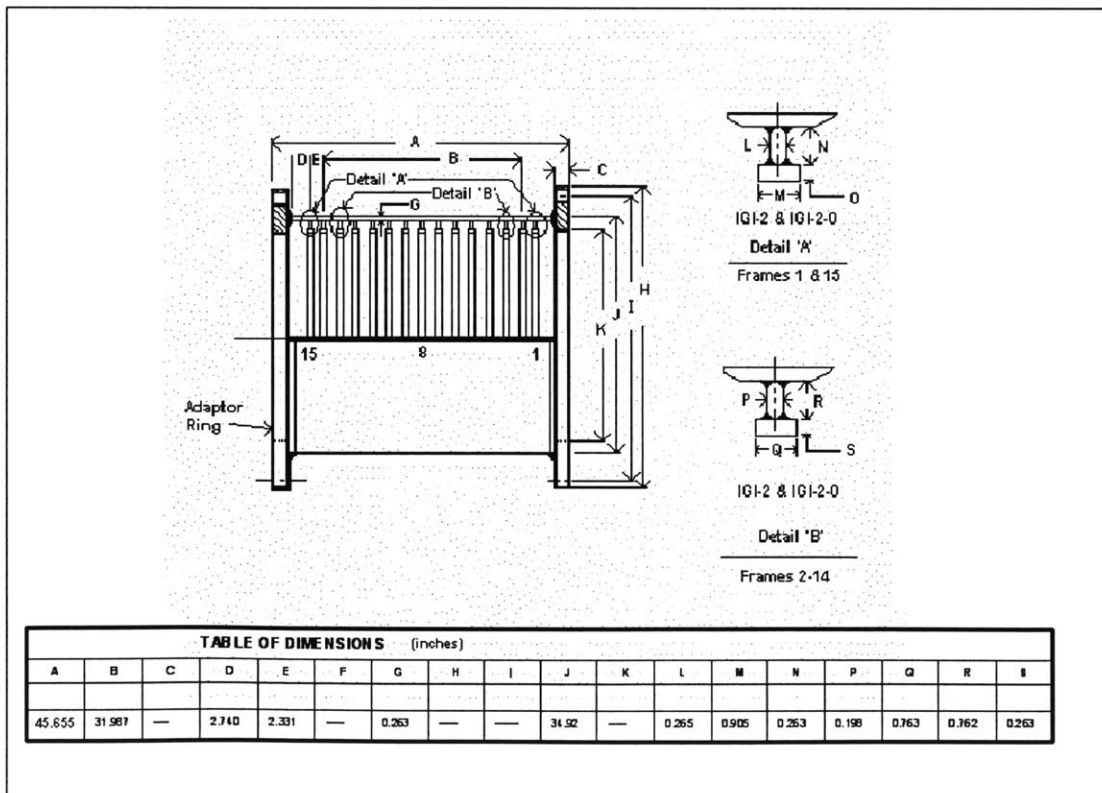

### 7.1.3 Cylinder 2.a

Cylinder 2.a was a machined cylindrical shell with external tee stiffeners. The material used was high strength steel with yield strength 65,500 psi. Figure 7 shows the structure and dimensions of the test cylinder. The boundary conditions consisted of end closures made of 3.0 inch steel plates attached to the idealized adaptor ring with full fixity. External uniform hydrostatic pressure was applied to the model. The cylinder tests the ability of the analysis methods to predict end bay failure (shell collapse influenced by end bay design). Specifically this model provides an example of axisymmetric buckling. The experimental collapse pressure was determined to be 921 psi by axisymmetric collapse in the second bay from the adaptor ring.

**Figure 7: Test Cylinder 2.a Structural Dimensions**

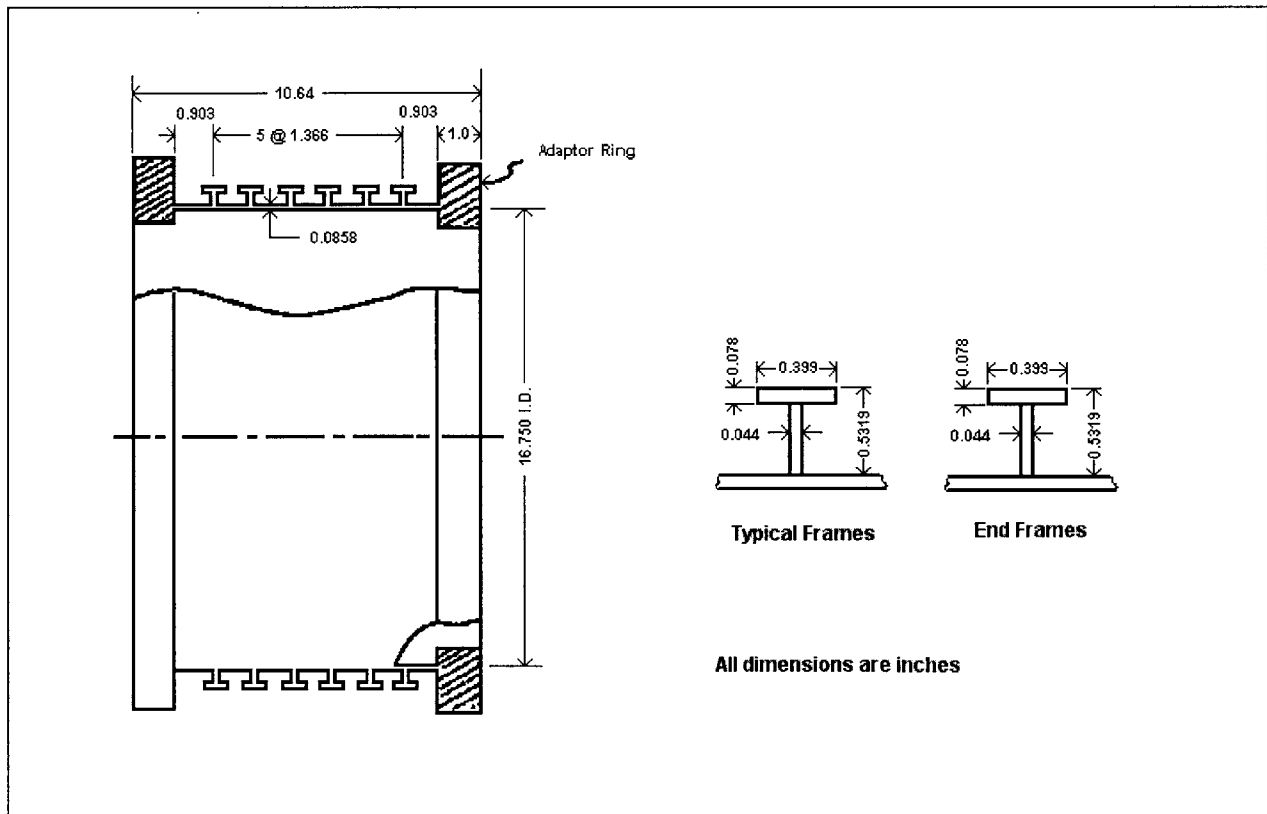

### 7.1.4 Cylinder 2.c

Cylinder 2.c was a fabricated cylinder with internal ring-stiffeners. The base material used was high strength steel with yield strength of 157,000 psi. Figure 8 shows the structure and dimensions of the cylinder. The shell was cold rolled and fabricated with a deliberate out-of-roundness imperfection. The frames were built-up. The frame web material was base metal, and the frame flanges were cold rolled. The boundary conditions consisted of one end being fully fixed with the other end having all freedoms except axial displacement. External uniform hydrostatic pressure with an axial end load to simulate end plate loading was applied. The test cylinder was used to predict the inelastic general instability failure mode and to model out-of-roundness imperfections. In the current analysis the out-of-roundness was not considered, and inaccuracies in predicted results were expected. The collapse pressure was experimentally found to be 3640 psi in two circumferential waves in an inelastic general instability mode.

**Figure 8: Test Cylinder 2.c Structural Dimensions**

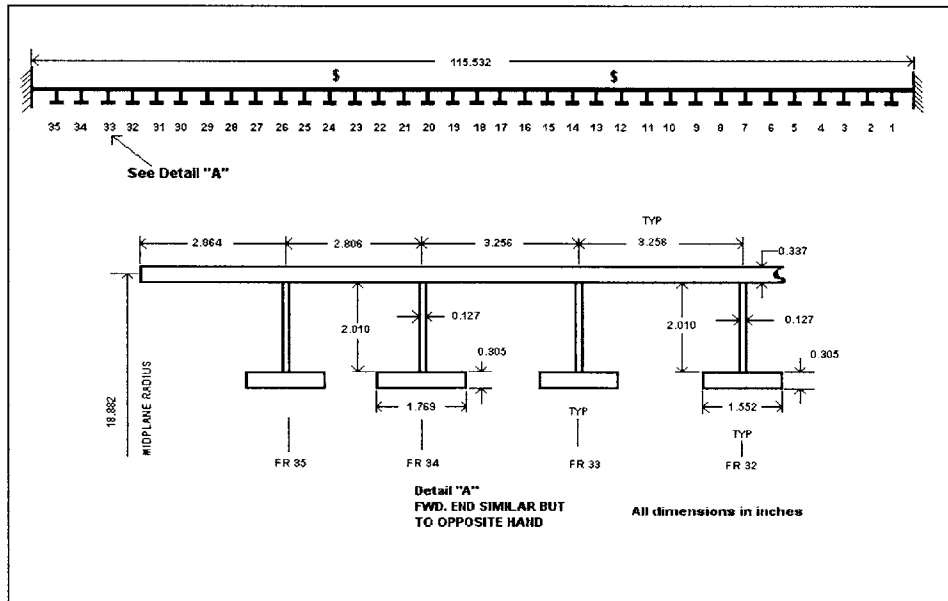

## 7.2 Calculation to Experimental Comparison

The dimensions of each of the test cylinders were used to calculate a predicted failure mode and failure pressure for the analytic solution, numerical solution, and classification society design rules (Appendix A-D). Table 1 shows the comparison of the predicted solutions to the experimental results. The table displays the calculated failure mode and failure pressure for each test cylinder.

**Table 1: Comparison of Predicted Failure Mode and Pressure to Experimental Data**

	Cyl 1.d		Cyl 1.f		Cyl 2.a		Cyl 2.c	
	Pressure	Mode	Pressure	Mode	Pressure	Mode	Pressure	Mode
<b>Experiment</b>	633	L	2200	GI	921	AX	3640	GI
<b>Analytic</b>	623	L	2176	AX	885	AX	4137	AX
<b>API (Bull 2U)</b>	447	L	1838	GI	710	L	3784	GI
<b>DNV (RP-C202)</b>	164	L	1089	GI	487	GI	2457	GI
<b>MAESTRO</b>	567	L	1920	GI	797	L	4167	GI
Key:           L           Asymmetric (Lobar) Buckling AX          Axisymmetric Yielding GI          General Instability  Note:           API, DNV, and MAESTRO only address L and GI for ring-stiffened cylinders								

The comparative analysis for each of the test cylinders is discussed in the following sections.

### 7.2.1 Cylinder 1.d Results

Cylinder 1.d was designed to test the ability of design tools to predict asymmetric buckling failure. There was excellent agreement between the predicted failure modes and the experimentally determined failure mode. Asymmetric buckling was expected since the

slenderness ratio was 201, much greater than the breakpoint (1.14) between asymmetric and axisymmetric failure. Specific comparisons for cylinder 1.d are shown in Table 2 and Figure 9.

**Table 2: Predicted Failure Pressures and Modes for Cylinder 1.d**

	Failure Pressure (psi)	Failure Mode	% From Experiment
<b>Experiment</b>	<b>633</b>	L	---
<b>Analytic Solution</b>	623	L	-1.6
<b>API (Bull 2U)</b>	447	L	-29.4
<b>DNV (RP-C202)</b>	164	L	-74.1
<b>MAESTRO</b>	567	L	-10.4

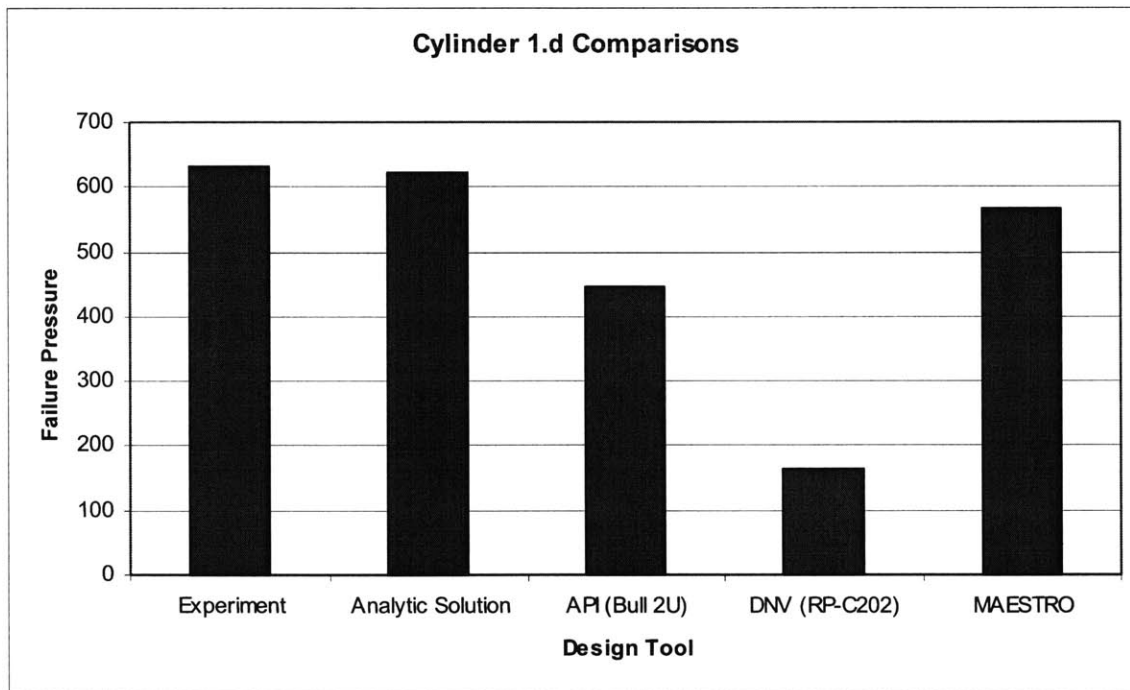

**Figure 9: Comparison of Predicted Failure Pressures for Cylinder 1.d**

The predicted failure pressures covered a large range of values. The closed-form analytic solution was very close to the experimental value, being only 1.6% below the critical pressure. The classification society design rules significantly under predicted the failure pressure. In the

case of API (Bull 2U), the discrepancy is attributable to the reduction factors applied for cylinder imperfections and residual stresses due to fabrication. Test cylinder 1.d was machined, therefore these reduction factors would not be applicable. DNV (RP-C202) is based on a semi-empirical solution and the results are closely tied to the specific cylinders used to develop the empirical relationships. Cylinder 1.d is relatively small and therefore is not modeled well by the DNV design rules. The MAESTRO™ solution under predicted the failure pressure by approximately 10%.

### 7.2.2 Cylinder 1.f Results

Cylinder 1.f was fabricated to test the ability of design tools to predict general instability. The cylinder failed under experiment at 2200 psi by general instability. There was excellent agreement between the predicted failure modes and the experimentally determined failure mode. Specific comparisons for cylinder 1.f are shown in Table 3 and Figure 10.

**Table 3: Predicted Failure Pressures and Modes for Cylinder 1.f**

	<b>Failure Pressure (psi)</b>	<b>Failure Mode</b>	<b>% From Experiment</b>
<b>Experiment</b>	<b>2200</b>	GI	---
<b>Analytic Solution</b>	2176	AX	-1.1
<b>API (Bull 2U)</b>	1838	GI	-16.5
<b>DNV (RP-C202)</b>	1089	GI	-50.5
<b>MAESTRO</b>	1920	GI	-12.7



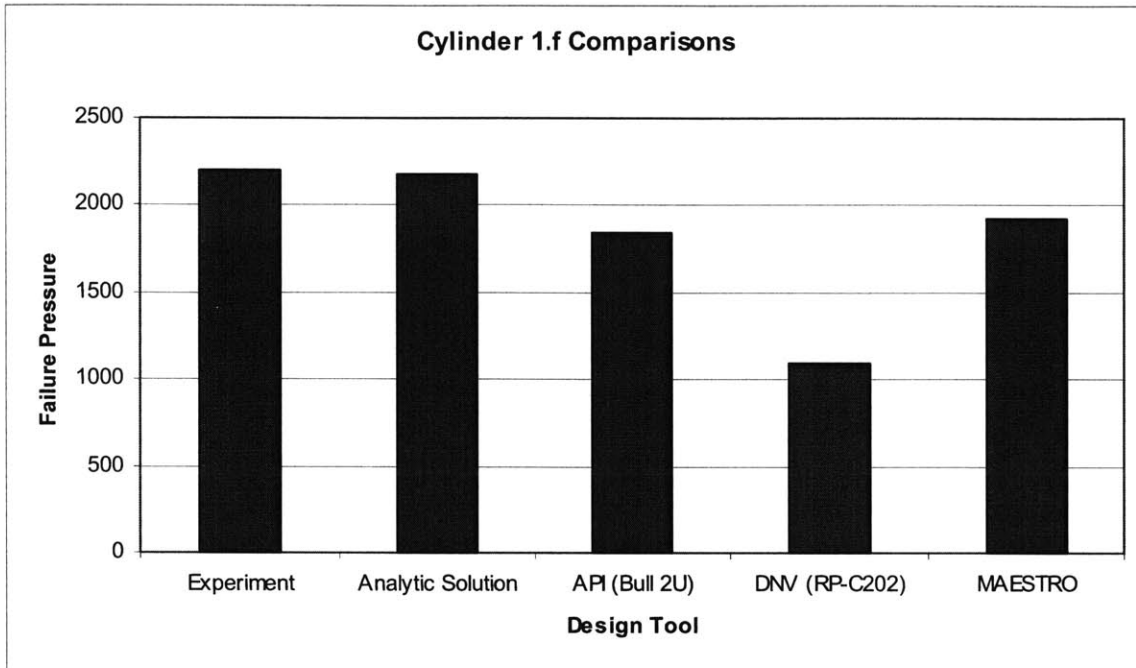

**Figure 10: Comparison of Predicted Failure Pressures for Cylinder 1.f**

All solutions except the closed-form analytic solution predicted that the cylinder would fail by general instability. The analytic solution predicted that the failure would be by axisymmetric yielding at a pressure that was very close to the experimental failure pressure (-1.1%). In the case of API (Bull 2U), a form of the Bryant equation was used to calculate the failure pressure for general instability, and the difference from experimental value is attributed to the difference between reduction factors and actual imperfections and residual stresses. DNV (RP-C202) again significantly under predicted the failure pressure. Cylinder 1.f was slightly larger than cylinder 1.d, but still not on the size scale of typical marine structures, contributing to the difference found in the DNV prediction. The MAESTRO™ solution under predicted the failure pressure by approximately 13%.

### 7.2.3 Cylinder 2.a Results

Cylinder 2.a was fabricated to test the ability of the design tools to predict axisymmetric yielding. Of the solutions used for the current analysis, only the analytic solution addresses axisymmetric yielding and provides a failure pressure. Test cylinder 2.a was experimentally determined to fail by axisymmetric yield at 921 psi. Specific comparisons for cylinder 2.a are shown in Table 4 and Figure 11.

**Table 4: Predicted Failure Pressures and Modes for Cylinder 2.a**

	Failure Pressure (psi)	Failure Mode	% From Experiment
<b>Experiment</b>	<b>921</b>	AX	---
<b>Analytic Solution</b>	885	AX	-3.9
<b>API (Bull 2U)</b>	710	L	-22.9
<b>DNV (RP-C202)</b>	487	GI	-47.1
<b>MAESTRO</b>	797	L	-13.5

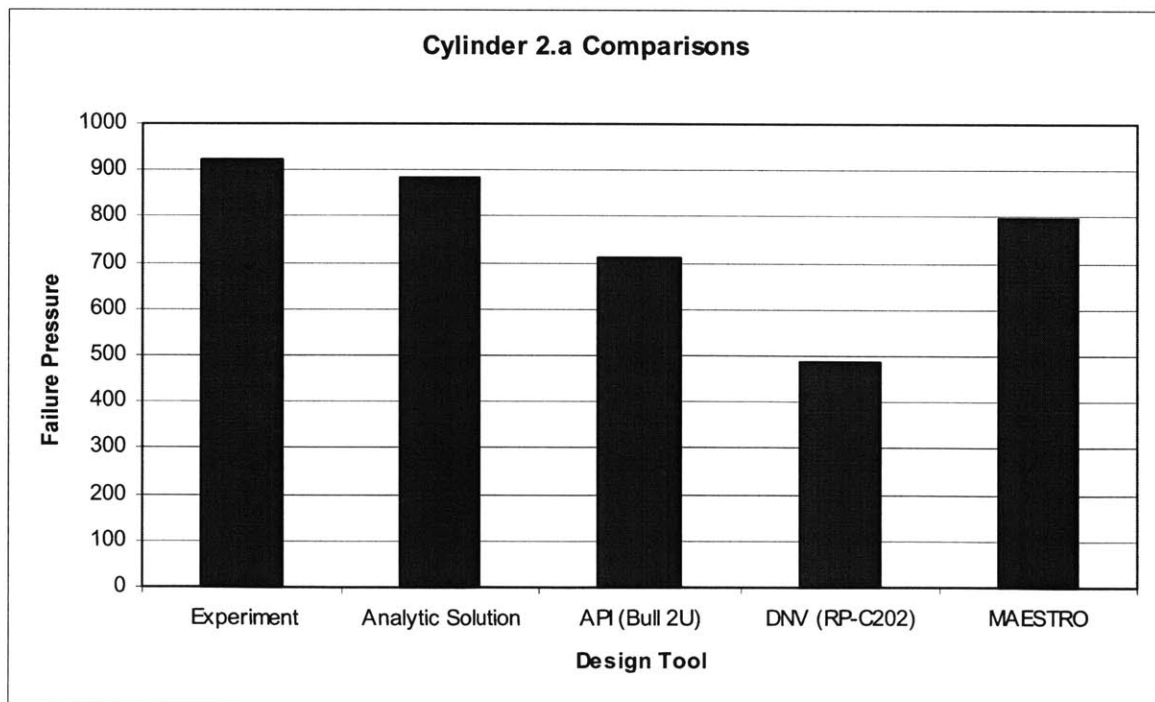

**Figure 11: Comparison of Predicted Failure Pressures for Cylinder 2.a**

The predicted failure modes for cylinder 2.a varied significantly between the design tools used. Axisymmetric yield was expected since the slenderness ratio was 0.698, much less than the breakpoint (1.14) between asymmetric and axisymmetric failure. In the case of the analytic solution, the correct failure mode was predicted and the failure pressure was within in 4% of experimental value, showing a good correlation. API (Bull 2U) and DNV (RP-C202) do not calculate an axisymmetric yield failure pressure. Most large marine structures have a slenderness ratio greater than 1.14, therefore it is presumed that API and DNV are primarily concerned with these types of structures and do not consider axisymmetric yield important for their design rules. MAESTRO™ uses API (Bull 2U, 1987 edition) for its calculations and therefore does not address axisymmetric yield either.

#### 7.2.4 Cylinder 2.c Results

Cylinder 2.c was fabricated to test the ability of the design tools to predicted general instability and model out-of-roundness imperfections. While none of the design tools used explicitly modeled out-of-roundness imperfections, the classification society design rules do apply generic reduction factors for imperfections and residual stresses. There was generally good agreement between the predicted failure modes and the experimentally determined failure mode. Specific comparisons for cylinder 2.c are shown in Table 5 and Figure 12.

**Table 5: Predicted Failure Pressures and Modes for Cylinder 2.c**

	Failure Pressure (psi)	Failure Mode	% From Experiment
<b>Experiment</b>	<b>3640</b>	GI	---
<b>Analytic Solution</b>	4137	AX	13.7
<b>API (Bull 2U)</b>	3784	GI	4.0
<b>DNV (RP-C202)</b>	2457	GI	-32.5
<b>MAESTRO</b>	4167	GI	14.5

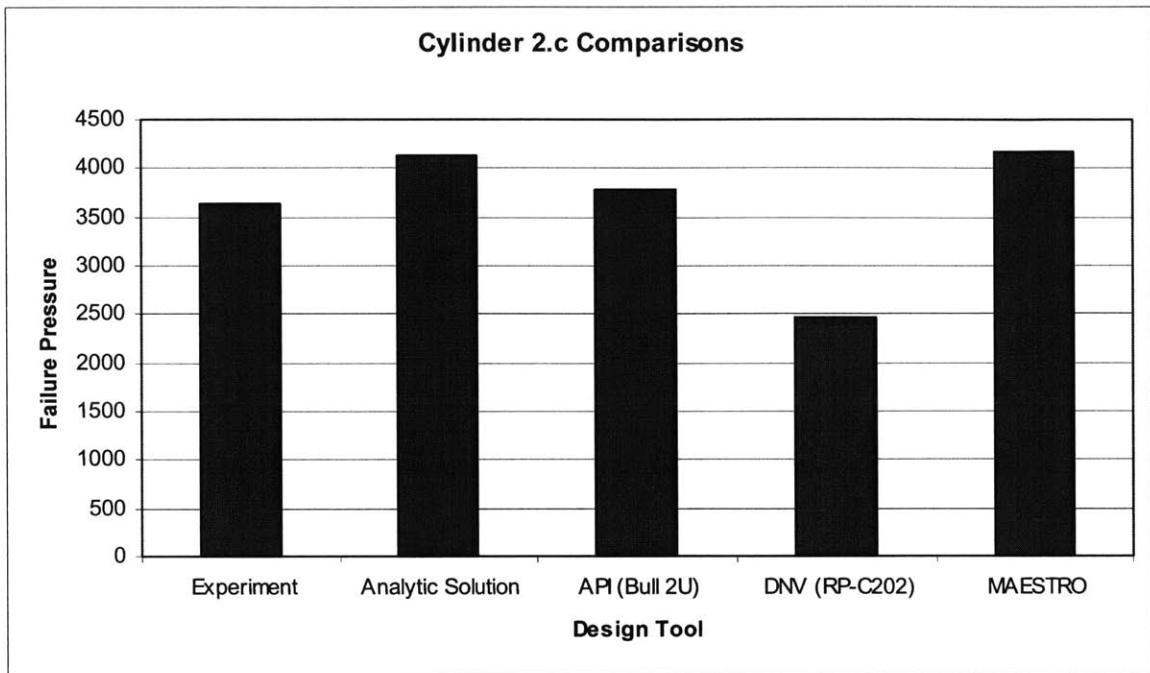

**Figure 12: Comparison of Predicted Failure Pressures for Cylinder 2.c**

All solutions except the closed-form analytic solution predicted that the cylinder would fail by general instability. The analytic solution predicted that the failure would be by axisymmetric yield at a pressure approximately 14% greater than the actual failure pressure. In the case of API (Bull 2U), the predicted failure pressure was very close to the actual failure pressure (4% over) with the error attributed to the rough approximations used for nominal imperfection levels. DNV (RP-C202) once again predicted the correct failure mode, but greatly under predicted the failure pressure. The MAESTRO™ solution over predicted the failure pressure by approximately 15%.

### 7.3 Comparison to Previous Work

Analysis was previously conducted by D. Price [4], comparing the failure modes and pressures of the same test cylinders (cylinders 1.d, 1.f, 2.a, 2.c) using different classification society design rules and guides. Table 6 shows the comparison of [4] to the current analysis.

**Table 6: Comparison With Previous Work**

	Cyl 1.d		Cyl 1.f		Cyl 2.a		Cyl 2.c	
	Pressure	Mode	Pressure	Mode	Pressure	Mode	Pressure	Mode
<b>Experiment</b>	633	L	2200	GI	921	AX	3640	GI
<b>Analytic</b>	623	L	2176	AX	885	AX	4137	AX
<b>ABS</b>	605	L	2039	AX	844	AX	4211	AX
<b>Germanischer Lloyd</b>	606	L	2931	AX	1030	AX	4567	AX
<b>SNAME</b>	605	L	1928	AX	815	AX	3864	AX
<b>API (Bull 2U)</b>	447	L	1838	GI	710	L	3784	GI
<b>DNV (RP-C202)</b>	164	L	1089	GI	487	GI	2457	GI
<b>MAESTRO</b>	567	L	1920	GI	797	L	4167	GI

Key:	L	Lobar Buckling		previous work
	AX	Axisymmetric Yielding		
	GI	General Instability		
Note:	API, DNV, and MAESTRO only address L and GI for ring-stiffened cylinders			

The classification society design rules and guides examined in [4] were: The American Bureau of Shipping (ABS) (*Rules for Building and Classing Underwater Vehicles, Systems and Hyperbaric Facilities*, 1990 Edition), Germanischer Lloyd (*Rules for Underwater Technology*, 1998 Edition), and Society of Naval Architects and Marine Engineers (SNAME) (*Submersible Vehicle Systems Design*, 1990 Edition). The design tools used in [4] all predicted the same failure mode as the analytic solution. This was due primarily to the fact that most of the

solutions for these rules and guides were based on closed-form solutions similar to those used in the analytic solution. In the case of cylinders 1.d and 2.a, the design rules and guides predicted the correct failure mode for both cylinders, and failure pressures were all within 12% of the experimental value. Cylinders 1.f and 2.c though, were predicted to fail by axisymmetric yield and instead failed by general instability. This discrepancy, when determining failure by general instability, indicates there may be some limitations with the closed-form analytic solution predicting a general instability failure.

## **CHAPTER 8: Conclusions**

The classification society design rules and numerical solution studied in this thesis are important tools for engineers and naval architects designing and manufacturing ring-stiffened cylindrical structures (like submarines) subjected to external hydrostatic pressure. The design engineer must have confidence in his analysis tools and be assured that they will provide appropriate, and safe calculations for the structure under consideration. Confidence can be assured by comparison of the calculated failure pressure and mode to those determined experimental through physical model tests. This thesis attempted to provide that comparison by using two widely used classification society design rules along with a numerical analysis program to compare analytical, numerical, and experimental results.

### **8.1 Comparative Analysis Review**

As discussed in Chapter 5, the design rules and numerical methods had mixed results in correctly predicting the failure mode and failure pressure of the test cylinders. In general, the classification society design rules and the numerical solution correctly predicted the failure mode for the types of failures addressed by these sources (asymmetric buckling and general instability). In the case of axisymmetric yield though, as found in cylinder 2.a, API (Bull 2U) and MAESTRO™ predicted failure by asymmetric buckling (local shell buckling) and DNV (RP-C202) predicted failure by general instability. Failure pressures were not predicted well by the design rules with API predicting failure at a pressure 16% lower on average than actual, and DNV predicting failure at a pressure 51% lower on average than actual. The numerical solution, MAESTRO™, performed markedly better predicting a failure pressure 5.5% lower on average than actual. In general, the classification society design rules and numerical solution all were

overly conservative when predicting failure pressures for the cylinders fabricated within normal tolerances. Cylinder 2.c was manufactured with a deliberate 0.105 inch out-of-roundness that resulted in all the design tools, except DNV (RP-C202), predicting failure at a pressure higher than experimental.

## **8.2 Agreements and Discrepancies**

In this thesis there were sixteen failure pressures calculated (four failures for each of four test cylinders). To provide a useful comparison methodology for the design tools that did not address axisymmetric yielding, failure by asymmetric buckling (lobal) and axisymmetric yield were both considered to be a local failure of the shell (between the stiffeners) and considered a similar failure mode. Local shell failure was then contrasted to general instability that was a failure of the shell and ring-stiffener. Using these guidelines for comparison, the design tools (Analytic, API, DNV, MAESTRO™) correctly predicted 81% of the failure modes. The failure pressures calculated varied from experimental by 1% to 74%.

The closed-form analytic solution correctly predicted the failure mode for two of the four test cylinders and predicted a failure pressure within 4% for those two cases. Both test cylinders that failed by inelastic general instability, were incorrectly predicted to fail by axisymmetric yield. This indicates that the two modes of failure are very close together and that the closed-form solution has difficulty discerning the two failure modes.

The API (Bull 2U) solution correctly predicted local shell failure and general instability in all four of the test cylinders and predicted the failure pressure within 29% of the experimental value. Since the API solution is based on the von Mises equation (10) for local shell buckling and the Bryant equation (12) for general instability, it was expected that the results would be similar to the analytic solution. The differences between the API and experimental results can be



attributed to two sources. First, the constants used in API (Bull 2U) are derived from actual test data. Being empirical in nature, these values are closely correlated to the size and dimensions of the models tested to determine the coefficients. In the case of the four test cylinders that were analyzed, their dimensions were smaller than those used to determine the empirical constants. Second, the reduction factors applied (imperfections and residual stress) do not accurately model the test cylinders (e.g. two test cylinders were machined, where the constant imperfection reductions would not be accurate). As a result, some inaccuracies in the predicted pressures were encountered.

The DNV (RP-C202) solution correctly predicted local shell failure and general instability in three of the four test cylinders but significantly under predicted the failure pressure by 33% to 74% of the experimental value. The differences between the DNV and experimental results are attributed to the semi-empirical nature of the equations in the rules. The constants and equations used in DNV (RP-C202) are empirically derived and therefore closely correlated to the size and dimensions of the models used to determine them. There were no limitations on applicability stated in the rules, but there were large discrepancies noted in the predicted failure pressures. This appears to indicate the DNV rules are more applicable to large marine structures instead of smaller submersible or submarine designs.

The MAESTRO™ solution correctly predicted local shell failure and general instability in all four of the test cylinders and predicted the failure pressure within 15% of the experimental value. The MAESTRO™ cylinder analysis function is based on the design rules from API (Bull 2U, 1987 edition), and was therefore expected to provide results similar to those from the design rules. The MAESTRO™ solution was somewhat more accurate than the design rules because it allows for the use of non-uniform stiffeners and spacing. Additionally, the cylinder can be

modeled in whole including the end plates and fixturing. The added flexibility of MAESTRO™ appeared to improve the accuracy of the predicted failure pressures over the other two classification society design rules.

### **8.3 Applications of the Results**

The various design rules and numerical methods studied are promulgated to ensure a safe and adequate design of ring-stiffened cylinders for use under external hydrostatic pressure. The safe design requires a high degree of certainty that the cylinder will not fail under the worse case anticipated conditions. The comparison of the closed-form analytic solution, the classification society design rules (API and DNV), and the numerical solution (MAESTRO™) to experimental results allows a designer to have a good understanding of the strengths and limitations of each analysis method. The ability to compare design predictions would be useful in judging the initial feasibility of a design and also the case where a specific design is subject to more than one classification society.

The solutions and comparisons in this thesis should in no way be used as detailed design tools for construction of ring-stiffened cylinders. Instead, a useful methodology for early stage design can be developed from these comparisons. First, an initial design can be quickly developed using closed-form analytic solutions similar to those in Appendix A. Next, the size and dimensions of the initial design can be evaluated using one of the classification society design rules, Appendix C and D (in this case, API (Bull 2U) is recommended over DNV (RP-C202) due to better predictions of failure pressures). The classification society design rules are a good check on the analytic solution because of the use of empirical data in the derivations of the equations. Finally, the design can be model using MAESTRO™, which allows the designer much greater flexibility in the complexity of design. The MAESTRO™ solution was generally

found to be a good first-order design approximation that predicted failure pressures within 15% of experimental results. The overall size and dimensions taken from MAESTRO™ can provide the designer a good estimate of the structural material required to build the cylinder or submarine, which in turn can be used to approximate the structural weight.

After the initial design is refined and judged to be adequate, a much more rigorous analyses must be used to ensure a safe design. These advanced analyses should include a finite element analysis with higher fidelity (e.g. ADINA™ or ABAQUS™) than the current analysis, and other tools that can provide a more detailed local stress analysis. These higher order analysis tools can account for material differences, geometric out-of-roundness, and actual construction factors such as heat affected zones due to welding, and bulkhead effects.

#### **8.4 Further Areas of Study**

There are several areas that require further research to completely understand the results of the analysis conducted in this thesis. The area most evident in need of more study is the large difference between the predicted failure pressures determined using the classification society design rules, API (Bull 2U) and DNV (RP-C202), and the actual failure pressures. Due to the semi-empirical nature of these design tools, it is expected that larger test cylinders (with diameter to thickness ratios greater than 300) would provide more accurate failure predictions. To accomplish this analysis, more test cylinder data would need to be obtained with careful attention paid to diameter to thickness ratio, radius to thickness ratio, and minimum thickness specifications.

There are other classification societies that produce design rules for stiffened cylinders and other geometries. These societies include NORSOK (Norway), Lloyd's Register (United Kingdom), Registro Italiano Group (RINA) (Italy) and several others. These additional design

rules could be compared against the existing test cylinders. More importantly, the design rules used in [4] and the design rules used in this thesis could be compared using additional experimental test cylinder data.

Finally, the source code for MAESTRO™ was written based on formulations from API (Bull 2U, 1987 edition). The source code should be updated to reflect the current edition (2000) of API (Bull 2U). MAESTRO™ could then be used for comparisons to other finite element programs (e.g. ADINA™ or ABAQUS™) to determine the relative strengths and weaknesses of each.

## List of References

- [1] W. A. Nash, *Hydrostatically Loaded Structures: The Structural Mechanics, Analysis and Design of Powered Submersibles*. Tarrytown, NY: Pergamon Press, 1995.
- [2] C. T. F. Ross, "The Collapse of Ring-Reinforced Cylinders Under Uniform External Pressure," *Transactions of The Royal Institution of Naval Architects*, VMI-15, vol. 107, pp. 375-394, 1965.
- [3] E. Wenk, JR., "Pressure Vessel Analysis of Submarine Hulls," *Welding Journal*, Reprinted from June 1961.
- [4] D. J. Price, *Comparison of Approaches for Determining the Failure of Stiffened Cylindrical Shells*. MIT-Cambridge, MA: Price, 2002.
- [5] American Petroleum Institute, *Bulletin on Stability Design of Cylindrical Shells*. API Bulletin 2U, 2<sup>nd</sup> Edition, Washington, D.C.: American Petroleum Institute, 2000.
- [6] Det Norske Veritas, *Recommended Practice on Buckling Strength of Shells*. DNV-RP-C202, Norway: Det Norske Veritas, 2002.
- [7] O. F. Hughes, *Ship Structural Design: A Rationally-Based, Computer-Aided Optimization Approach*. Jersey City, NJ: Society of Naval Architects and Marine Engineers, 1988.
- [8] I. H. Shames and J. M. Pitarresi, *Introduction to Solid Mechanics*, Third Edition. Upper Saddle River, NJ: Prentice Hall, 2000.
- [9] Society of Naval Architects and Marine Engineers, *Principles of Naval Architecture*. New York: The Society of Naval Architects and Marine Engineers, 1967.

- [10] J. G. Pulos and V. L. Salerno, "Axisymmetric Elastic Deformations and Stresses in a Ring-Stiffened, Perfectly Circular Cylindrical Shell Under External Hydrostatic Pressure," West Bethesda, MD. David Taylor Model Basin Report 1497, 1961.
- [11] Optimum Structural Design, Inc., *Basic Features Manual for MAESTRO™ Program Version 8.0*. Stevensville, MD: Optimum Structural Design, Inc.(Proteus Engineering), 1999.
- [12] W. Will, Private Conversations. Naval Sea Systems Command (NAVSEA 05P2), Washington, D.C. 2003.

## **Appendices**

Page Intentionally Left Blank



# Appendix A: Analytic Solution

Page Intentionally Left Blank

# Analytic Solution

## NAVSEA Test Cylinder 1.d

### General Defintions

$$\text{ksi} := 6.89475710^6 \text{Pa} \quad \text{rtog} := 64.0 \frac{\text{lbft}}{\text{ft}^3} \quad \text{kip} := 1000 \text{bf} \quad \text{bload} := 1 \frac{\text{kip}}{\text{in}}$$

$E := 30000 \text{ksi}$  Young's Modulus of Elasticity

$R_i := 8.007 \text{in}$  Inner radius of cylinder

$\sigma_y := 80 \text{ksi}$  Yield strength

$L_f := 4.266 \text{in}$  Length of supported cylinder  $L_f = 4.266 \text{in}$

$L_b := 22.488 \text{in}$  Distance between bulkheads  $L_b = 22.488 \text{in}$

$\nu := .3$  Poison's ratio for Fe/Steel

$h := 0.081 \text{in}$  Shell thickness  $h = 0.081 \text{in}$

### Ring Stiffener Dimensions

$t_w := 0.138 \text{in}$  thickness of web of ring stiffener  $t_w = 0.138 \text{in}$

$h_w := 0.57 \text{in}$  height of web of ring stiffener  $h_w = 0.57 \text{in}$

$b := t_w$  faying width of stiffener (from P&S for I beam stiffener)

$b_f := 0.0 \text{in}$  breadth of flange of ring stiffener  $b_f = 0 \text{in}$

$t_f := 0.0 \text{in}$  flange thickness of ring stiffener  $t_f = 0 \text{in}$

$R := R_i + \frac{h}{2}$  radius of cylinder to mid-line of shell  $R = 8.047 \text{in}$

$D := 2 \cdot R$  diameter of cylinder  $D = 16.095 \text{in}$

$$L := L_f - b \quad \text{unsupported shell length} \quad L = 4.128\text{in}$$

$$c_1 := \frac{\frac{t_w \cdot h_w^2}{2} + t_f \cdot b_f \left( h_w + \frac{t_f}{2} \right)}{t_w \cdot h_w + t_f \cdot b_f} \quad \text{dist from shell to centroid} \quad c_1 = 0.285\text{in}$$

$$c_2 := h_w - c_1 \quad \text{dist from centroid to end of flange} \quad c_2 = 0.285\text{in}$$

$$R_{cg} := R + .5 \cdot h + c_1 \quad \text{radius to centroid of ring stiffener (external stiffeners)} \quad R_{cg} = 8.373\text{in}$$

$$A_f := (t_w \cdot h_w + b_f \cdot t_f) \quad \text{cross-sectional area of ring stiffener} \quad A_f = 0.079\text{in}^2$$

$$A_{eff} := A_f \left( \frac{R}{R_{cg}} \right) \quad \text{effective area of stiffener eqn [24a] from P\&S} \quad A_{eff} = 0.076\text{in}^2$$

$$\alpha := \frac{A_{eff}}{L_f \cdot h} \quad \text{ratio of effective frame area to shell area eqn [62] P\&S} \quad \alpha = 0.219$$

$$\beta := \frac{b}{L_f} \quad \text{ratio of faying width to frame spacing eqn [62] P\&S} \quad \beta = 0.032$$

# Failure Modes

## a. Axisymmetric Buckling (AX)

Based on Poulos and Salerno, 1961

```

P_cab :=
  γ ← 0
  limit ← 5psi
  test ← 0psi
  convert ← 1psi
  j ← 0
  while j ≤ 10
    η1 ←  $\frac{1}{2} \cdot \sqrt{1 - \gamma}$ 
    η2 ←  $\frac{1}{2} \cdot \sqrt{1 + \gamma}$ 
    θ ←  $\sqrt[4]{3 \cdot (1 - \nu^2)} \cdot \frac{L}{\sqrt{R \cdot h}}$ 
    F1 ←  $\frac{4}{\theta} \cdot \frac{\cosh(\eta_1 \cdot \theta)^2 - \cos(\eta_2 \cdot \theta)^2}{\frac{\cosh(\eta_1 \cdot \theta) \cdot \sinh(\eta_1 \cdot \theta)}{\eta_1} + \frac{\cos(\eta_2 \cdot \theta) \cdot \sin(\eta_2 \cdot \theta)}{\eta_2}}$ 
    F2 ←  $\frac{\frac{\cosh(\eta_1 \cdot \theta) \cdot \sin(\eta_2 \cdot \theta)}{\eta_2} + \frac{\sinh(\eta_1 \cdot \theta) \cdot \cos(\eta_2 \cdot \theta)}{\eta_1}}{\frac{\cosh(\eta_1 \cdot \theta) \cdot \sinh(\eta_1 \cdot \theta)}{\eta_1} + \frac{\cos(\eta_2 \cdot \theta) \cdot \sin(\eta_2 \cdot \theta)}{\eta_2}}$ 
    F4 ←  $\sqrt{\frac{3}{1 - \nu^2}} \cdot \frac{\frac{\cosh(\eta_1 \cdot \theta) \cdot \sin(\eta_2 \cdot \theta)}{\eta_2} - \frac{\sinh(\eta_1 \cdot \theta) \cdot \cos(\eta_2 \cdot \theta)}{\eta_1}}{\frac{\cosh(\eta_1 \cdot \theta) \cdot \sinh(\eta_1 \cdot \theta)}{\eta_1} + \frac{\cos(\eta_2 \cdot \theta) \cdot \sin(\eta_2 \cdot \theta)}{\eta_2}}$ 
    A ←  $\frac{\left(1 - \frac{\nu}{2}\right) \cdot \alpha}{\alpha + \beta + (1 - \beta) \cdot F_1}$ 
    κ1 ←  $A^2 \cdot \left[ F_2^2 + F_2 \cdot F_4 \cdot (1 - 2 \cdot \nu) \cdot \left( \sqrt{\frac{0.91}{1 - \nu^2}} \right) + F_4^2 \cdot (1 - \nu + \nu^2) \cdot \left( \frac{0.91}{1 - \nu^2} \right) \right]$ 
    κ2 ←  $\left( \frac{3}{2} \right) \cdot A \cdot \left( F_2 - \nu \cdot F_4 \cdot \sqrt{\frac{0.91}{1 - \nu^2}} \right)$ 
    pc ←  $\frac{\sigma_y \cdot \left( \frac{h}{R} \right)}{\sqrt{\frac{3}{4} + \kappa_1 - \kappa_2}}$ 
    break if |pc - test| ≤ limit
    γ ←  $\frac{p_c}{2 \cdot E} \cdot \left[ \sqrt{3 \cdot (1 - \nu^2)} \right] \cdot \left( \frac{R}{h} \right)^2$ 
    test ← pc
    j ← j + 1
    out0 ←  $\frac{p_c}{convert}$ 
    out1 ← j
  end while
  out

```

$$P_{cab} = \left( \begin{array}{c} 874.261 \\ 2 \end{array} \right)$$

$$P_{cAX} := P_{cab} \cdot 1 \text{psi}$$

$$P_{cAX} = 874.26 \text{psi}$$

### **b. Asymmetric Collapse (Lobar Buckling) (LB)**

**Based on von Mises theory, with approximations by Windenburg, 1933**

Windenburg approximation assumes number of lobes (n) is  $\pi \cdot 2P/L$

$$P_{cLB} := \frac{2.42 \cdot E \cdot \left(\frac{h}{D}\right)^{\frac{5}{2}}}{(1 - \nu^2)^{\frac{3}{4}} \cdot \left[ \left(\frac{L}{D}\right) - 0.45 \left(\frac{h}{D}\right)^{\frac{1}{2}} \right]}$$

Lobar buckling  
[PNA eqn 19]

$$P_{cLB} = 623.477 \text{psi}$$

### **c. General Instability (GI)**

**Based on Kendrick, 1954**

Moment of Inertia Calculations for combined plate and stiffener

$$\theta := \sqrt[4]{3 \cdot (1 - \nu^2)} \cdot \frac{L}{\sqrt{R \cdot h}}$$

$$L_e := 1.56 \sqrt{R \cdot h} \cdot \left( \frac{\cosh(\theta) - \cos(\theta)}{\sinh(\theta) + \sin(\theta)} \right) \quad \text{effective shell length, [P\&S eqn 92]}$$

$$L_e = 1.255 \text{in}$$

$$d := h_w + \frac{h}{2} + \frac{t_f}{2}$$

$$A_p := L_e \cdot h \quad A_w := t_w \cdot h_w \quad A_{fl} := t_f \cdot b_f \quad A_T := A_p + A_w + A_{fl}$$

$$C_1 := \frac{A_w \left( \frac{A_T}{3} - \frac{A_w}{4} \right) + A_{fl} \cdot A_p}{A_T^2}$$

$$I_e := A_T \cdot d^2 \cdot C_1 \quad \text{moment of inertia for combined plate/stiffener}$$

[Hughes eqn 8.3.6]

$$I_e = 0.007 \text{in}^4$$

#### General Instability Calculation

$$\lambda := \frac{\pi R}{L_b}$$

$$n := 1$$

$$p_{cGI}^{(n)} := \frac{E \cdot h}{R} \left[ \frac{\lambda^4}{\left( n^2 + \frac{\lambda^2}{2} - 1 \right) \cdot \left( n^2 + \lambda^2 \right)^2} \right] + \frac{(n^2 - 1) \cdot E \cdot I_e}{R^3 \cdot L_f}$$

General Instability  
calculation  
[SNAME eqn 10]

Given

$$n \geq 1$$

$$n_{gi} := \text{Minimiz}(p_{cGI}, n)$$

$$n_{gi} = 3.258 \quad \text{must be integer value}$$

$$n_{gi\_int} := \text{round}(n_{gi})$$

$$n_{gi\_int} = 3$$

$$n_{gi\_range} := \begin{pmatrix} n_{gi\_int} - 2 \\ n_{gi\_int} - 1 \\ n_{gi\_int} \\ n_{gi\_int} + 1 \\ n_{gi\_int} + 2 \end{pmatrix}$$

$$P_{cGI\_range} := \begin{pmatrix} P_{cGI}(n_{gi\_range}_0) \\ P_{cGI}(n_{gi\_range}_1) \\ P_{cGI}(n_{gi\_range}_2) \\ P_{cGI}(n_{gi\_range}_3) \\ P_{cGI}(n_{gi\_range}_4) \end{pmatrix} \quad P_{cGI\_range} = \begin{pmatrix} 148926.73 \\ 5059.37 \\ 1240.24 \\ 1434.37 \\ 2157.73 \end{pmatrix} \text{ psi}$$

$$P_{cGI} := \min(P_{cGI\_range})$$

$$P_{cGI} = 1240.24 \text{ psi}$$

## Summary

**Axisymmetric Buckling**  $P_{cAX} = 874.26 \text{ psi}$

**Lobar Buckling**  $P_{cLB} = 623.48 \text{ psi}$

**General Instability**  $P_{cGI} = 1240.24 \text{ psi}$



# Analytic Solution

## NAVSEA Test Cylinder 1.f

### General Defintions

$\text{ksi} := 6.89475710^6 \text{Pa}$	$\text{rtog} := 64.0 \frac{\text{lbft}}{\text{ft}^3}$	$\text{kip} := 1000 \text{bf}$	$\text{bload} := 1 \frac{\text{kip}}{\text{in}}$
$E := 3000 \text{ksi}$	Young's Modulus of Elasticity		
$R_i := 17.197 \text{in}$	Inner radius of cylinder		
$\sigma_y := 98.5 \text{ksi}$	Yield strength		
$L_f := 2.666 \text{in}$	Length of supported cylinder	$L_f = 2.666 \text{in}$	
$L_b := 42.129 \text{in}$	Distance between bulkheads	$L_b = 42.129 \text{in}$	
$\nu := .3$	Poison's ratio for Fe/Steel		
$h := 0.263 \text{in}$	Shell thickness	$h = 0.263 \text{in}$	

### Ring Stiffener Dimensions

$t_w := 0.198 \text{in}$	thickness of web of ring stiffener	$t_w = 0.198 \text{in}$
$h_w := 0.762 \text{in}$	height of web of ring stiffener	$h_w = 0.762 \text{in}$
$b := t_w$	faying width of stiffener (from P&S for I beam stiffener)	
$b_f := 0.763 \text{in}$	breadth of flange of ring stiffener	$b_f = 0.763 \text{in}$
$t_f := 0.263 \text{in}$	flange thickness of ring stiffener	$t_f = 0.263 \text{in}$
$R := R_i + \frac{h}{2}$	radius of cylinder to mid-line of shell	$R = 17.328 \text{in}$
$D := 2 \cdot R$	diameter of cylinder	$D = 34.657 \text{in}$

$$L := L_f - b \quad \text{unsupported shell length} \quad L = 2.468\text{in}$$

$$c_1 := \frac{\frac{t_w \cdot h_w^2}{2} + t_f \cdot b_f \left( h_w + \frac{t_f}{2} \right)}{t_w \cdot h_w + t_f \cdot b_f} \quad \text{dist from shell to centroid} \quad c_1 = 0.674\text{in}$$

$$c_2 := h_w - c_1 \quad \text{dist from centroid to end of flange} \quad c_2 = 0.088\text{in}$$

$$R_{cg} := R - .5 \cdot h - c_1 \quad \text{radius to centroid of ring stiffener (external stiffeners)} \quad R_{cg} = 16.523\text{in}$$

$$A_f := (t_w \cdot h_w + b_f \cdot t_f) \quad \text{cross-sectional area of ring stiffener} \quad A_f = 0.352\text{in}^2$$

$$A_{eff} := A_f \left( \frac{R}{R_{cg}} \right) \quad \text{effective area of stiffener eqn [24a] from P\&S} \quad A_{eff} = 0.369\text{in}^2$$

$$\alpha := \frac{A_{eff}}{L_f \cdot h} \quad \text{ratio of effective frame area to shell area eqn [62] P\&S} \quad \alpha = 0.526$$

$$\beta := \frac{b}{L_f} \quad \text{ratio of faying width to frame spacing eqn [62] P\&S} \quad \beta = 0.074$$

# Failure Modes

## a. Axisymmetric Buckling (AX)

Based on Poulos and Salerno, 1961

```

P_cab :=
  γ ← 0
  limit ← 5 psi
  test ← 0 psi
  convert ← 1 psi
  j ← 0
  while j ≤ 10
    η1 ←  $\frac{1}{2} \cdot \sqrt{1 - \gamma}$ 
    η2 ←  $\frac{1}{2} \cdot \sqrt{1 + \gamma}$ 
    θ ←  $\sqrt{3 \cdot (1 - \nu^2)} \cdot \frac{L}{\sqrt{R \cdot h}}$ 
    F1 ←  $\frac{4}{\theta} \cdot \frac{\cosh(\eta_1 \cdot \theta)^2 - \cos(\eta_2 \cdot \theta)^2}{\frac{\cosh(\eta_1 \cdot \theta) \cdot \sinh(\eta_1 \cdot \theta)}{\eta_1} + \frac{\cos(\eta_2 \cdot \theta) \cdot \sin(\eta_2 \cdot \theta)}{\eta_2}}$ 
    F2 ←  $\frac{\cosh(\eta_1 \cdot \theta) \cdot \sin(\eta_2 \cdot \theta) + \sinh(\eta_1 \cdot \theta) \cdot \cos(\eta_2 \cdot \theta)}{\frac{\eta_2}{\cosh(\eta_1 \cdot \theta) \cdot \sinh(\eta_1 \cdot \theta)} + \frac{\eta_1}{\cos(\eta_2 \cdot \theta) \cdot \sin(\eta_2 \cdot \theta)}}$ 
    F4 ←  $\sqrt{\frac{3}{1 - \nu^2}} \cdot \frac{\cosh(\eta_1 \cdot \theta) \cdot \sin(\eta_2 \cdot \theta) - \sinh(\eta_1 \cdot \theta) \cdot \cos(\eta_2 \cdot \theta)}{\frac{\eta_2}{\cosh(\eta_1 \cdot \theta) \cdot \sinh(\eta_1 \cdot \theta)} + \frac{\eta_1}{\cos(\eta_2 \cdot \theta) \cdot \sin(\eta_2 \cdot \theta)}}$ 
    A ←  $\frac{\left(1 - \frac{\nu}{2}\right) \cdot \alpha}{\alpha + \beta + (1 - \beta) \cdot F_1}$ 
    κ1 ←  $A^2 \cdot \left[ F_2^2 + F_2 \cdot F_4 \cdot (1 - 2 \cdot \nu) \cdot \left( \sqrt{\frac{0.91}{1 - \nu^2}} \right) + F_4^2 \cdot (1 - \nu + \nu^2) \cdot \left( \frac{0.91}{1 - \nu^2} \right) \right]$ 
    κ2 ←  $\left( \frac{3}{2} \right) \cdot A \cdot \left( F_2 - \nu \cdot F_4 \cdot \sqrt{\frac{0.91}{1 - \nu^2}} \right)$ 
    Pc ←  $\frac{\sigma_y \cdot \left( \frac{h}{R} \right)}{\sqrt{\frac{3}{4} + \kappa_1 - \kappa_2}}$ 
    break if |Pc - test| ≤ limit
    γ ←  $\frac{P_c}{2 \cdot E} \cdot \left[ \sqrt{3 \cdot (1 - \nu^2)} \right] \cdot \left( \frac{R}{h} \right)^2$ 
    test ← Pc
    j ← j + 1
    out0 ←  $\frac{P_c}{convert}$ 
    outj ← j
  out
  
```

$$P_{cab} = \left( \frac{2.176 \times 10^3}{2} \right)$$

$$P_{cAX} := P_{cab_0} \cdot \text{psi}$$

$$P_{cAX} = 2176.44 \text{psi}$$

### **b. Asymmetric Collapse (Lobar Buckling) (LB)**

**Based on von Mises theory, with approximations by Windenburg, 1933**

Windenburg approximation assumes number of lobes (n) is  $\pi \cdot 2P/L$

$$P_{cLB} := \frac{2.42 \cdot E \cdot \left(\frac{h}{D}\right)^{\frac{5}{2}}}{(1 - \nu^2)^{\frac{3}{4}} \cdot \left[ \left(\frac{L}{D}\right) - 0.45 \left(\frac{h}{D}\right)^{\frac{1}{2}} \right]}$$

Lobar buckling  
[PNA eqn 19]

$$P_{cLB} = 12211.34 \text{psi}$$

### **c. General Instability (GI)**

**Based on Kendrick, 1954**

Moment of Inertia Calculations for combined plate and stiffener

$$\theta := \sqrt[4]{3 \cdot (1 - \nu^2)} \cdot \frac{L}{\sqrt{R \cdot h}}$$

$$L_e := 1.56 \sqrt{R \cdot h} \cdot \left( \frac{\cosh(\theta) - \cos(\theta)}{\sinh(\theta) + \sin(\theta)} \right) \quad \text{effective shell length, [P\&S eqn 92]}$$

$$L_e = 2.41 \text{ in}$$

$$d := h_w + \frac{h}{2} + \frac{t_f}{2}$$

$$A_p := L_e \cdot h \quad A_w := t_w \cdot h_w \quad A_{fl} := t_f \cdot b_f \quad A_T := A_p + A_w + A_{fl}$$

$$C_1 := \frac{A_w \left( \frac{A_T}{3} - \frac{A_w}{4} \right) + A_{fl} \cdot A_p}{A_T^2}$$

$$I_e := A_T \cdot d^2 \cdot C_1 \quad \text{moment of inertia for combined plate/stiffener} \\ \text{[Hughes eqn 8.3.6]}$$

$$I_e = 0.182 \text{in}^4$$

#### General Instability Calculation

$$\lambda := \frac{\pi R}{L_b}$$

$$n := 1$$

$$p_{cGI}^{(n)} := \frac{E \cdot h}{R} \left[ \frac{\lambda^4}{\left( n^2 + \frac{\lambda^2}{2} - 1 \right) \cdot \left( n^2 + \lambda^2 \right)^2} \right] + \frac{\left( n^2 - 1 \right) \cdot E \cdot I_e}{R^3 \cdot L_f} \quad \text{General Instability calculation} \\ \text{[SNAME eqn 10]}$$

Given

$$n \geq 1$$

$$n_{gi} := \text{Minimize}(p_{cGI}, n)$$

$$n_{gi} = 2.984 \quad \text{must be integer value}$$

$$n_{gi\_int} := \text{round}(n_{gi})$$

$$n_{gi\_int} = 3$$

$$n_{gi\_range} := \begin{pmatrix} n_{gi\_int} - 2 \\ n_{gi\_int} - 1 \\ n_{gi\_int} \\ n_{gi\_int} + 1 \\ n_{gi\_int} + 2 \end{pmatrix}$$

$$P_{cGI\_range} := \begin{pmatrix} P_{cGI}(n_{gi\_range}_0) \\ P_{cGI}(n_{gi\_range}_1) \\ P_{cGI}(n_{gi\_range}_2) \\ P_{cGI}(n_{gi\_range}_3) \\ P_{cGI}(n_{gi\_range}_4) \end{pmatrix} \quad P_{cGI\_range} = \begin{pmatrix} 213331.15 \\ 11481.17 \\ 4417.53 \\ 6173.06 \\ 9537.92 \end{pmatrix} \text{ psi}$$

$$P_{cGI} := \min(P_{cGI\_range})$$

$$P_{cGI} = 4417.53 \text{ psi}$$

## Summary

**Axisymmetric Buckling**  $P_{cAX} = 2176.44 \text{ psi}$

**Lobar Buckling**  $P_{cLB} = 12211.34 \text{ psi}$

**General Instability**  $P_{cGI} = 4417.53 \text{ psi}$

# Analytic Solution

## NAVSEA Test Cylinder 2.a

### General Definitions

$\text{ksi} := 6.89475710^6 \text{Pa}$	$\text{rtog} := 64.0 \frac{\text{lbft}}{\text{ft}^3}$	$\text{kip} := 1000 \text{bf}$	$\text{bload} := 1 \frac{\text{kip}}{\text{in}}$
$E := 3000 \text{ksi}$	Young's Modulus of Elasticity		
$R_i := 8.375 \text{in}$	Inner radius of cylinder		
$\sigma_y := 65.5 \text{ksi}$	Yield strength		
$L_f := 1.366 \text{in}$	Length of supported cylinder	$L_f = 1.366 \text{in}$	
$L_b := 8.636 \text{in}$	Distance between bulkheads	$L_b = 8.636 \text{in}$	
$\nu := .3$	Poison's ratio for Fe/Steel		
$h := .0858 \text{in}$	Shell thickness	$h = 0.086 \text{in}$	

### Ring Stiffener Dimensions

$t_w := .044 \text{in}$	thickness of web of ring stiffener	$t_w = 0.044 \text{in}$
$h_w := .4539 \text{in}$	height of web of ring stiffener	$h_w = 0.454 \text{in}$
$b := t_w$	faying width of stiffener (from P&S for I beam stiffener)	
$b_f := .399 \text{in}$	breadth of flange of ring stiffener	$b_f = 0.399 \text{in}$
$t_f := .078 \text{in}$	flange thickness of ring stiffener	$t_f = 0.078 \text{in}$
$R := R_i + \frac{h}{2}$	radius of cylinder to mid-line of shell	$R = 8.418 \text{in}$
$D := 2 \cdot R$	diameter of cylinder	$D = 16.836 \text{in}$

$$L := L_f - b \quad \text{unsupported shell length} \quad L = 1.322\text{in}$$

$$c_1 := \frac{\frac{t_w \cdot h_w^2}{2} + t_f \cdot b_f \left( h_w + \frac{t_f}{2} \right)}{t_w \cdot h_w + t_f \cdot b_f} \quad \text{dist from shell to centroid} \quad c_1 = 0.389\text{in}$$

$$c_2 := h_w - c_1 \quad \text{dist from centroid to end of flange} \quad c_2 = 0.065\text{in}$$

$$R_{cg} := R + .5 \cdot h + c_1 \quad \text{radius to centroid of ring stiffener (external stiffeners)} \quad R_{cg} = 8.85\text{in}$$

$$A_f := (t_w \cdot h_w + b_f \cdot t_f) \quad \text{cross-sectional area of ring stiffener} \quad A_f = 0.051\text{in}^2$$

$$A_{eff} := A_f \left( \frac{R}{R_{cg}} \right) \quad \text{effective area of stiffener eqn [24a] from P\&S} \quad A_{eff} = 0.049\text{in}^2$$

$$\alpha := \frac{A_{eff}}{L_f \cdot h} \quad \text{ratio of effective frame area to shell area eqn [62] P\&S} \quad \alpha = 0.415$$

$$\beta := \frac{b}{L_f} \quad \text{ratio of faying width to frame spacing eqn [62] P\&S} \quad \beta = 0.032$$



# Failure Modes

## a. Axisymmetric Buckling (AX)

Based on Poulos and Salerno, 1961

```

Pcab :=
  γ ← 0
  limit ← 5psi
  test ← 0psi
  convert ← 1psi
  j ← 0
  while j ≤ 10
    η1 ← 1/2 * √(1 - γ)
    η2 ← 1/2 * √(1 + γ)
    θ ← √(3 * (1 - ν²)) * L / √(R * h)
    F1 ← 4 * (cosh(η1 * θ)² - cos(η2 * θ)²) / (θ * (cosh(η1 * θ) * sinh(η1 * θ) / η1 + cos(η2 * θ) * sin(η2 * θ) / η2))
    F2 ← (cosh(η1 * θ) * sin(η2 * θ) / η2 + sinh(η1 * θ) * cos(η2 * θ) / η1) / (cosh(η1 * θ) * sinh(η1 * θ) / η1 + cos(η2 * θ) * sin(η2 * θ) / η2)
    F4 ← √(3 / (1 - ν²)) * (cosh(η1 * θ) * sin(η2 * θ) / η2 - sinh(η1 * θ) * cos(η2 * θ) / η1) / (cosh(η1 * θ) * sinh(η1 * θ) / η1 + cos(η2 * θ) * sin(η2 * θ) / η2)
    A ← ((1 - ν/2) * α) / (α + β + (1 - β) * F1)
    κ1 ← A² * [F2² + F2 * F4 * (1 - 2 * ν) * (√(0.91 / (1 - ν²))) + F4² * (1 - ν + ν²) * (0.91 / (1 - ν²))]
    κ2 ← (3/2) * A * (F2 - ν * F4 * √(0.91 / (1 - ν²)))
    pc ← (σy * (h/R)) / √(3/4 + κ1 - κ2)
    break if |pc - test| ≤ limit
    γ ← pc / (2 * E) * [√(3 * (1 - ν²))] * (R/h)²
    test ← pc
    j ← j + 1
  out0 ← pc / convert
  out1 ← j
  
```

$$P_{cab} = \begin{pmatrix} 884.668 \\ 2 \end{pmatrix}$$

$$P_{cAX} := P_{cab_0} \cdot 1 \text{ psi}$$

$$P_{cAX} = 884.67 \text{ psi}$$

### **b. Asymmetric Collapse (Lobar Buckling) (LB)**

**Based on von Mises theory, with approximations by Windenburg, 1933**

Windenburg approximation assumes number of lobes (n) is  $\pi \cdot 2P/L$

$$P_{cLB} := \frac{2.42 \cdot E \cdot \left(\frac{h}{D}\right)^{\frac{5}{2}}}{(1 - \nu^2)^{\frac{3}{4}} \cdot \left[ \left(\frac{L}{D}\right) - 0.45 \left(\frac{h}{D}\right)^{\frac{1}{2}} \right]}$$

Lobar buckling  
[PNA eqn 19]

$$P_{cLB} = 3113.77 \text{ psi}$$

### **c. General Instability (GI)**

**Based on Kendrick, 1954**

Moment of Inertia Calculations for combined plate and stiffener

$$\theta := \sqrt[4]{3 \cdot (1 - \nu^2)} \cdot \frac{L}{\sqrt{R \cdot h}}$$

$$L_e := 1.56 \sqrt{R \cdot h} \cdot \left( \frac{\cosh(\theta) - \cos(\theta)}{\sinh(\theta) + \sin(\theta)} \right) \quad \text{effective shell length, [P\&S eqn 92]}$$

$$L_e = 1.221 \text{ in}$$

$$d := h_w + \frac{h}{2} + \frac{t_f}{2}$$

$$A_p := L_e \cdot h \quad A_w := t_w \cdot h_w \quad A_{fl} := t_f \cdot b_f \quad A_T := A_p + A_w + A_{fl}$$

$$C_1 := \frac{A_w \left( \frac{A_T}{3} - \frac{A_w}{4} \right) + A_{fl} \cdot A_p}{A_T^2}$$

$$I_e := A_T \cdot d^2 \cdot C_1 \quad \text{moment of inertia for combined plate/stiffener}$$

[Hughes eqn 8.3.6]

$$I_e = 0.008 \text{in}^4$$

#### General Instability Calculation

$$\lambda := \frac{\pi R}{L_b}$$

$$n := 1$$

$$p_{cGI}^{(n)} := \frac{E \cdot h}{R} \left[ \frac{\lambda^4}{\left( n^2 + \frac{\lambda^2}{2} - 1 \right) \cdot \left( n^2 + \lambda^2 \right)^2} \right] + \frac{\left( n^2 - 1 \right) \cdot E \cdot I_e}{R^3 \cdot L_f}$$

General Instability  
calculation  
[SNAME eqn 10]

Given

$$n \geq 1$$

$$n_{gi} := \text{Minimize}(p_{cGI}, n)$$

$$n_{gi} = 3.975 \quad \text{must be integer value}$$

$$n_{gi\_int} := \text{round}(n_{gi})$$

$$n_{gi\_int} = 4$$

$$n_{gi\_range} := \begin{pmatrix} n_{gi\_int} - 2 \\ n_{gi\_int} - 1 \\ n_{gi\_int} \\ n_{gi\_int} + 1 \\ n_{gi\_int} + 2 \end{pmatrix}$$

$$P_{cGI\_range} := \begin{pmatrix} |P_{cGI}(n_{gi\_range}_0)| \\ |P_{cGI}(n_{gi\_range}_1)| \\ |P_{cGI}(n_{gi\_range}_2)| \\ |P_{cGI}(n_{gi\_range}_3)| \\ |P_{cGI}(n_{gi\_range}_4)| \end{pmatrix} \quad P_{cGI\_range} = \begin{pmatrix} 20396.34 \\ 8552.29 \\ 6391.31 \\ 7626.22 \\ 10294.03 \end{pmatrix} \text{ psi}$$

$$P_{cGI} := \min(P_{cGI\_range})$$

$$P_{cGI} = 6391.31 \text{ psi}$$

## Summary

**Axisymmetric Buckling**  $P_{cAX} = 884.67 \text{ psi}$

**Lobar Buckling**  $P_{cLB} = 3113.77 \text{ psi}$

**General Instability**  $P_{cGI} = 6391.31 \text{ psi}$

# Analytic Solution

## NAVSEA Test Cylinder 2.c

### General Defintions

$\text{ksi} := 6.89475710^6 \text{Pa}$	$\text{rtog} := 64.0 \frac{\text{lbf}}{\text{ft}^3}$	$\text{kip} := 1000 \text{lbf}$	$\text{load} := 1 \frac{\text{kip}}{\text{in}}$
$E := 3000 \text{ksi}$	Young's Modulus of Elasticity		
$R_i := 18.714 \text{in}$	Inner radius of cylinder		
$\sigma_y := 157 \text{ksi}$	Yield strength		
$L_f := 3.256 \text{in}$	Length of supported cylinder	$L_f = 3.256 \text{in}$	
$L_b := 115.532 \text{in}$	Distance between bulkheads	$L_b = 115.532 \text{in}$	
$\nu := .3$	Poisson's ratio for Fe/Steel		
$h := 0.337 \text{in}$	Shell thickness	$h = 0.337 \text{in}$	

### Ring Stiffener Dimensions

$t_w := 0.127 \text{in}$	thickness of web of ring stiffener	$t_w = 0.127 \text{in}$
$h_w := 2.01 \text{in}$	height of web of ring stiffener	$h_w = 2.01 \text{in}$
$b := t_w$	faying width of stiffener (from P&S for I beam stiffener)	
$b_f := 1.552 \text{in}$	breadth of flange of ring stiffener	$b_f = 1.552 \text{in}$
$t_f := 0.305 \text{in}$	flange thickness of ring stiffener	$t_f = 0.305 \text{in}$
$R := R_i + \frac{h}{2}$	radius of cylinder to mid-line of shell	$R = 18.883 \text{in}$
$D := 2 \cdot R$	diameter of cylinder	$D = 37.765 \text{in}$

$$L := L_f - b \quad \text{unsupported shell length} \quad L = 3.129\text{in}$$

$$c_1 := \frac{\frac{t_w \cdot h_w^2}{2} + t_f \cdot b_f \left( h_w + \frac{t_f}{2} \right)}{t_w \cdot h_w + t_f \cdot b_f} \quad \text{dist from shell to centroid} \quad c_1 = 1.757\text{in}$$

$$c_2 := h_w - c_1 \quad \text{dist from centroid to end of flange} \quad c_2 = 0.253\text{in}$$

$$R_{cg} := R - .5 \cdot h - c_1 \quad \text{radius to centroid of ring stiffener (internal stiffeners)} \quad R_{cg} = 16.957\text{in}$$

$$A_f := (t_w \cdot h_w + b_f \cdot t_f) \quad \text{cross-sectional area of ring stiffener} \quad A_f = 0.729\text{in}^2$$

$$A_{eff} := A_f \left( \frac{R}{R_{cg}} \right) \quad \text{effective area of stiffener eqn [24a] from P\&S} \quad A_{eff} = 0.811\text{in}^2$$

$$\alpha := \frac{A_{eff}}{L_f \cdot h} \quad \text{ratio of effective frame area to shell area eqn [62] P\&S} \quad \alpha = 0.739$$

$$\beta := \frac{b}{L_f} \quad \text{ratio of faying width to frame spacing eqn [62] P\&S} \quad \beta = 0.039$$

# Failure Modes

## a. Axisymmetric Buckling (AX)

Based on Poulos and Salerno, 1961

```

Pcab :=
  γ ← 0
  limit ← 5 psi
  test ← 0 psi
  convert ← 1 psi
  j ← 0
  while j ≤ 10
    η1 ←  $\frac{1}{2} \cdot \sqrt{1 - \gamma}$ 
    η2 ←  $\frac{1}{2} \cdot \sqrt{1 + \gamma}$ 
    θ ←  $\sqrt[4]{3 \cdot (1 - \nu^2)} \cdot \frac{L}{\sqrt{R \cdot h}}$ 
    F1 ←  $\frac{4}{\theta} \cdot \frac{\cosh(\eta_1 \cdot \theta)^2 - \cos(\eta_2 \cdot \theta)^2}{\frac{\cosh(\eta_1 \cdot \theta) \cdot \sinh(\eta_1 \cdot \theta)}{\eta_1} + \frac{\cos(\eta_2 \cdot \theta) \cdot \sin(\eta_2 \cdot \theta)}{\eta_2}}$ 
    F2 ←  $\frac{\frac{\cosh(\eta_1 \cdot \theta) \cdot \sin(\eta_2 \cdot \theta)}{\eta_2} + \frac{\sinh(\eta_1 \cdot \theta) \cdot \cos(\eta_2 \cdot \theta)}{\eta_1}}{\frac{\cosh(\eta_1 \cdot \theta) \cdot \sinh(\eta_1 \cdot \theta)}{\eta_1} + \frac{\cos(\eta_2 \cdot \theta) \cdot \sin(\eta_2 \cdot \theta)}{\eta_2}}$ 
    F4 ←  $\sqrt{\frac{3}{1 - \nu^2}} \cdot \frac{\frac{\cosh(\eta_1 \cdot \theta) \cdot \sin(\eta_2 \cdot \theta)}{\eta_2} - \frac{\sinh(\eta_1 \cdot \theta) \cdot \cos(\eta_2 \cdot \theta)}{\eta_1}}{\frac{\cosh(\eta_1 \cdot \theta) \cdot \sinh(\eta_1 \cdot \theta)}{\eta_1} + \frac{\cos(\eta_2 \cdot \theta) \cdot \sin(\eta_2 \cdot \theta)}{\eta_2}}$ 
    A ←  $\frac{\left(1 - \frac{\nu}{2}\right) \cdot \alpha}{\alpha + \beta + (1 - \beta) \cdot F_1}$ 
    κ1 ←  $A^2 \cdot \left[ F_2^2 + F_2 \cdot F_4 \cdot (1 - 2 \cdot \nu) \cdot \left( \sqrt{\frac{0.91}{1 - \nu^2}} \right) + F_4^2 \cdot (1 - \nu + \nu^2) \cdot \left( \frac{0.91}{1 - \nu^2} \right) \right]$ 
    κ2 ←  $\left( \frac{3}{2} \right) \cdot A \cdot \left( F_2 - \nu \cdot F_4 \cdot \sqrt{\frac{0.91}{1 - \nu^2}} \right)$ 
    Pc ←  $\frac{\sigma_y \cdot \left( \frac{h}{R} \right)}{\sqrt{\frac{3}{4} + \kappa_1 - \kappa_2}}$ 
    break if |Pc - test| ≤ limit
    γ ←  $\frac{P_c}{2 \cdot E} \cdot \left[ \sqrt{3 \cdot (1 - \nu^2)} \right] \cdot \left( \frac{R}{h} \right)^2$ 
    test ← Pc
    j ← j + 1
    out0 ←  $\frac{P_c}{\text{convert}}$ 
    out1 ← j
  out
  
```

$$P_{cab} = \left( \frac{4.137 \times 10^3}{2} \right)$$

$$P_{cAX} := P_{cab} \cdot 1 \text{psi}$$

$$P_{cAX} = 4137.25 \text{ psi}$$

### **b. Asymmetric Collapse (Lobar Buckling) (LB)**

**Based on von Mises theory, with approximations by Windenburg, 1933**

Windenburg approximation assumes number of lobes (n) is  $\pi \cdot 2P / L$

$$P_{cLB} := \frac{2.42 \cdot E \cdot \left(\frac{h}{D}\right)^{\frac{5}{2}}}{(1 - \nu^2)^{\frac{3}{4}} \cdot \left[ \left(\frac{L}{D}\right) - 0.45 \left(\frac{h}{D}\right)^{\frac{1}{2}} \right]}$$

Lobar buckling  
[PNA eqn 19]

$$P_{cLB} = 14528.26 \text{ psi}$$

### **c. General Instability (GI)**

**Based on Kendrick, 1954**

Moment of Inertia Calculations for combined plate and stiffener

$$\theta := \sqrt[4]{3 \cdot (1 - \nu^2)} \cdot \frac{L}{\sqrt{R \cdot h}}$$

$$L_e := 1.56 \sqrt{R \cdot h} \cdot \left( \frac{\cosh(\theta) - \cos(\theta)}{\sinh(\theta) + \sin(\theta)} \right) \quad \text{effective shell length, [P\&S eqn 92]}$$

$$L_e = 3.03 \text{ in}$$



$$d := h_w + \frac{h}{2} + \frac{t_f}{2}$$

$$A_p := L_e \cdot h \quad A_w := t_w \cdot h_w \quad A_{fl} := t_f \cdot b_f \quad A_T := A_p + A_w + A_{fl}$$

$$C_1 := \frac{A_w \left( \frac{A_T}{3} - \frac{A_w}{4} \right) + A_{fl} \cdot A_p}{A_T^2}$$

$$I_e := A_T \cdot d^2 \cdot C_1 \quad \text{moment of inertia for combined plate/stiffener}$$

[Hughes eqn 8.3.6]

$$I_e = 1.913 \text{in}^4$$

### General Instability Calculation

$$\lambda := \frac{\pi R}{L_b}$$

$$n := 1$$

$$p_{cGI}(n) := \frac{E \cdot h}{R} \left[ \frac{\lambda^4}{\left( n^2 + \frac{\lambda^2}{2} - 1 \right) \cdot (n^2 + \lambda^2)^2} \right] + \frac{(n^2 - 1) \cdot E \cdot I_e}{R^3 \cdot L_f}$$

General Instability  
calculation  
[SNAME eqn 10]

Given

$$n \geq 1$$

$$n_{gi} := \text{Minimize}(p_{cGI}, n)$$

$$n_{gi} = 1.657 \quad \text{must be integer value}$$

$$n_{gi\_int} := \text{round}(n_{gi})$$

$$n_{gi\_int} = 2$$

$$n_{gi\_range} := \begin{pmatrix} n_{gi\_int} - 2 \\ n_{gi\_int} - 1 \\ n_{gi\_int} \\ n_{gi\_int} + 1 \\ n_{gi\_int} + 2 \end{pmatrix}$$

$$P_{cGI\_range} := \begin{pmatrix} |P_{cGI}(n_{gi\_range}_0)| \\ |P_{cGI}(n_{gi\_range}_1)| \\ |P_{cGI}(n_{gi\_range}_2)| \\ |P_{cGI}(n_{gi\_range}_3)| \\ |P_{cGI}(n_{gi\_range}_4)| \end{pmatrix} \quad P_{cGI\_range} = \begin{pmatrix} 619329.53 \\ 176802.28 \\ 8506.69 \\ 20994.71 \\ 39274.39 \end{pmatrix} \text{ psi}$$

$$P_{cGI} := \min(P_{cGI\_range})$$

$$P_{cGI} = 8506.69 \text{ psi}$$

## Summary

**Axisymmetric Buckling**  $P_{cAX} = 4137.25 \text{ psi}$

**Lobar Buckling**  $P_{cLB} = 14528.26 \text{ psi}$

**General Instability**  $P_{cGI} = 8506.69 \text{ psi}$

## **Appendix B: Numerical Solution**

Page Intentionally Left Blank

# Numerical Solution (MAESTRO, version 8.5)

## NAVSEA Test Cylinder 1.d

### General Defintions

$E := 30000 \text{ ksi}$	Young's Modulus of Elasticity	$\text{ksi} := 6.89475710^6 \text{ Pa}$
$F_y := 80 \text{ ksi}$	Yield Strength	
$\nu := .3$	Poison's ratio for Fe/Steel	
$t := 0.08 \text{ in}$	thickness of shell	
$R_i := 8.007 \text{ in}$	Inner radius of cylinder	
$D_0 := 2 \cdot (R_i + t)$	diameter to outside of shell	$D_0 = 16.176 \text{ in}$
$L_T := 4.266 \text{ in}$	ring spacing (frame center to frame center)	
$L_b := 22.488 \text{ in}$	length of cylinder between bulkheads or lines of support	
$R := \frac{D_0}{2} - \frac{t}{2}$		
$R = 8.047 \text{ in}$	radius to centerline of shell	

### Ring Stiffener Dimensions

$t_w := 0.138 \text{ in}$	thickness of web of ring stiffener	$t_w = 0.138 \text{ in}$
$h_w := 0.57 \text{ in}$	height of web of ring stiffener	$h_w = 0.57 \text{ in}$
$b := t_w$	faying width of stiffener (from P&S for I beam stiffener)	
$b_f := 0.0 \text{ in}$	breadth of flange of ring stiffener	$b_f = 0 \text{ in}$
$t_f := 0.0 \text{ in}$	flange thickness of ring stiffener	$t_f = 0 \text{ in}$

MAESTRO Modeler representation of cylinder 1.d

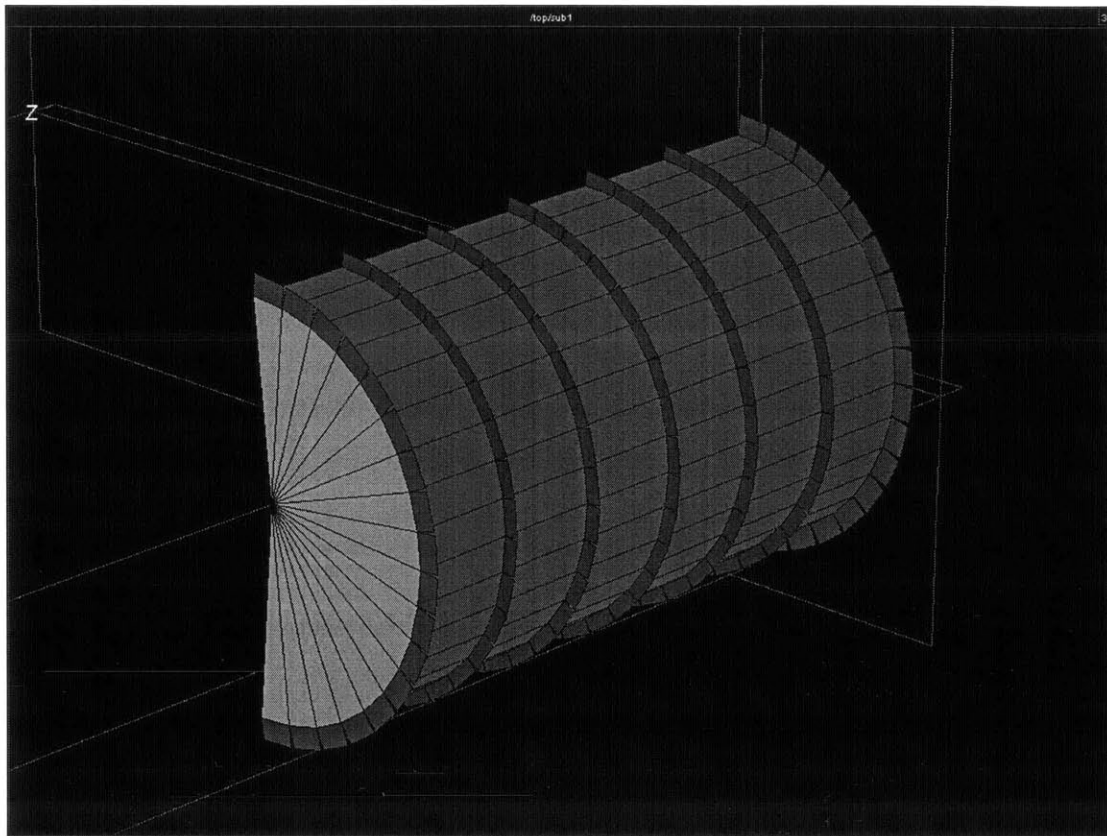

MAESTRO Version 8.5.0  
 HYDROSTATIC TEST - CYL 1.D

29-APR-2003 PAGE 1

=====

VERSION OF DATA SET IS 8.1.1

JOB TYPE: STRUCTURAL ANALYSIS  
 DEFLECTIONS TO BE SAVED ON FILE CYL 1D-2.DEF

STRUCTURE PARAMETERS:  
 \*\*\*\*\*

PLOT LEVEL =	2
TRANSVERSE SYMMETRY INDICATOR =	2
LEVEL OF OUTPUT REGARDING F. E. MODEL =	1
DEFAULT EVALUATION LEVEL =	3
STATION SPACING FOR PRINTING SUMMED	
VERTICAL LOADS =	1st sectn.
FIRST SUBSTRUCTURE IN NODE RENUMBERING:	1
FIRST MODULE IN NODE RENUMBERING:	1
GLOBAL X VALUE FOR STATION 0:	Lowest value
IF 1, SUPPRESS OUT-OF-PLANE DEFLECTION	
OF UNSTIFFENED COMPOUND NODES:	0

REFERENCE COORDINATES OF STRUCTURE ORIGIN AND OCEAN SURFACE				
KEYWORD	XREF.	YREF.	ZREF.	OCEAN SURFACE
REFERENCE	0.000	0.000	0.000	0.000

Module 1 of Substructure 1

DATA GROUP IV(A) - DEFINITION OF STRAKES

TYPE	STRAKE	ENDPOINT NUMBERS		MATERIAL TYPE			EFFECT. SPAN	PANEL TYPE	RADIUS OR		FRAME WEB ANGLE	LOAD ALLOCATION OR		EVAL. LEVEL
		EDGE 1	EDGE 2	PLT	STIFF	FRM			REF. STRAKE			OPP. R & SEC/BAY		
BOTTOM	1	1	2	1	1	1	4.26	LCYL	H+3.05E-02	+X TRANS	H+3.05E-02	0	3	
BOTTOM	2	2	3	1	1	1	4.26	LCYL	H+3.05E-02	+X TRANS	H+3.05E-02	0	3	
BOTTOM	3	3	4	1	1	1	4.26	LCYL	H+3.05E-02	+X TRANS	H+3.05E-02	0	3	
BOTTOM	4	4	5	1	1	1	4.26	LCYL	H+3.05E-02	+X TRANS	H+3.05E-02	0	3	
BOTTOM	5	5	6	1	1	1	4.26	LCYL	H+3.05E-02	+X TRANS	H+3.05E-02	0	3	
BOTTOM	6	6	7	1	1	1	4.26	LCYL	H+3.05E-02	+X TRANS	H+3.05E-02	0	3	
BOTTOM	7	7	8	1	1	1	4.26	LCYL	H+3.05E-02	+X TRANS	H+3.05E-02	0	3	
BOTTOM	8	8	9	1	1	1	4.26	LCYL	H+3.05E-02	+X TRANS	H+3.05E-02	0	3	
BOTTOM	9	9	10	1	1	1	4.26	LCYL	H+3.05E-02	+X TRANS	H+3.05E-02	0	3	
BOTTOM	10	10	11	1	1	1	4.26	LCYL	H+3.05E-02	+X TRANS	H+3.05E-02	0	3	
BOTTOM	11	11	12	1	1	1	4.26	LCYL	H+3.05E-02	+X TRANS	H+3.05E-02	0	3	
BOTTOM	12	12	13	1	1	1	4.26	LCYL	H+3.05E-02	+X TRANS	H+3.05E-02	0	3	
BOTTOM	13	13	14	1	1	1	4.26	LCYL	H+3.05E-02	+X TRANS	H+3.05E-02	0	3	
BOTTOM	14	14	15	1	1	1	4.26	LCYL	H+3.05E-02	+X TRANS	H+3.05E-02	0	3	
BOTTOM	15	15	16	1	1	1	4.26	LCYL	H+3.05E-02	+X TRANS	H+3.05E-02	0	3	
BOTTOM	16	16	17	1	1	1	4.26	LCYL	H+3.05E-02	+X TRANS	H+3.05E-02	0	3	
BOTTOM	17	17	18	1	1	1	4.26	LCYL	H+3.05E-02	+X TRANS	H+3.05E-02	0	3	
BOTTOM	18	18	19	1	1	1	4.26	LCYL	H+3.05E-02	+X TRANS	H+3.05E-02	0	3	

GROUP VI (B) - SHELL TRIANGLE ELEMENTS

LABEL OR SEQ. NO.	NODE 1		NODE 2		NODE 3		MATL. TYPE	PLATE THICK.	PANEL CODE	H.G. EFF.
	ENPT	SEC	ENPT	SEC	ENPT	SEC				

Module 2 of Substructure 1

DATA GROUP IV(A) - DEFINITION OF STRAKES

TYPE	STRAKE	ENDPOINT NUMBERS		MATERIAL TYPE			EFFECT. SPAN	PANEL TYPE	RADIUS OR REF. STRAKE	FRAME WEB ANGLE	LOAD ALLOCATION OR		EVAL. LEVEL
		EDGE 1	EDGE 2	PLT	STIFF	FRM					OPP. R	SEC/BAY	
BOTTOM	1	1	2	1	1	1	4.26	LCYL	H+3.05E-02	+X TRANS	H+3.05E-02	0	3
BOTTOM	2	2	3	1	1	1	4.26	LCYL	H+3.05E-02	+X TRANS	H+3.05E-02	0	3
BOTTOM	3	3	4	1	1	1	4.26	LCYL	H+3.05E-02	+X TRANS	H+3.05E-02	0	3
BOTTOM	4	4	5	1	1	1	4.26	LCYL	H+3.05E-02	+X TRANS	H+3.05E-02	0	3
BOTTOM	5	5	6	1	1	1	4.26	LCYL	H+3.05E-02	+X TRANS	H+3.05E-02	0	3
BOTTOM	6	6	7	1	1	1	4.26	LCYL	H+3.05E-02	+X TRANS	H+3.05E-02	0	3
BOTTOM	7	7	8	1	1	1	4.26	LCYL	H+3.05E-02	+X TRANS	H+3.05E-02	0	3
BOTTOM	8	8	9	1	1	1	4.26	LCYL	H+3.05E-02	+X TRANS	H+3.05E-02	0	3
BOTTOM	9	9	10	1	1	1	4.26	LCYL	H+3.05E-02	+X TRANS	H+3.05E-02	0	3
BOTTOM	10	10	11	1	1	1	4.26	LCYL	H+3.05E-02	+X TRANS	H+3.05E-02	0	3
BOTTOM	11	11	12	1	1	1	4.26	LCYL	H+3.05E-02	+X TRANS	H+3.05E-02	0	3
BOTTOM	12	12	13	1	1	1	4.26	LCYL	H+3.05E-02	+X TRANS	H+3.05E-02	0	3
BOTTOM	13	13	14	1	1	1	4.26	LCYL	H+3.05E-02	+X TRANS	H+3.05E-02	0	3
BOTTOM	14	14	15	1	1	1	4.26	LCYL	H+3.05E-02	+X TRANS	H+3.05E-02	0	3
BOTTOM	15	15	16	1	1	1	4.26	LCYL	H+3.05E-02	+X TRANS	H+3.05E-02	0	3
BOTTOM	16	16	17	1	1	1	4.26	LCYL	H+3.05E-02	+X TRANS	H+3.05E-02	0	3
BOTTOM	17	17	18	1	1	1	4.26	LCYL	H+3.05E-02	+X TRANS	H+3.05E-02	0	3
BOTTOM	18	18	19	1	1	1	4.26	LCYL	H+3.05E-02	+X TRANS	H+3.05E-02	0	3
END													

ENDCOMP

GROUP VI(B) - SHELL TRIANGLE ELEMENTS

LABEL OR SEQ. NO.	NODE 1		NODE 2		NODE 3		MATL. TYPE	PLATE THICK.	PANEL CODE	H.G. EFF.
	ENPT	SEC	ENPT	SEC	ENPT	SEC				
T1	2	3	-1	0	1	3	1	3.00	W	
T2	3	3	-1	0	2	3	1	3.00	W	
T3	4	3	-1	0	3	3	1	3.00	W	
T4	5	3	-1	0	4	3	1	3.00	W	
T5	6	3	-1	0	5	3	1	3.00	W	
T6	7	3	-1	0	6	3	1	3.00	W	
T7	8	3	-1	0	7	3	1	3.00	W	
T8	9	3	-1	0	8	3	1	3.00	W	
T9	10	3	-1	0	9	3	1	3.00	W	
T10	11	3	-1	0	10	3	1	3.00	W	



**LOAD CASE: HYDROSTATIC PRESSURE - 567 PSI**

HYDROSTATIC TEST - CYL 1.D

=====

INITIAL PANEL ADEQUACY PARAMETER VALUES - MODULE 1 OF SUBSTR. 1

-----

STRAKE	CCBB	CCGB	PCMY	CCLB	PYTF	PYTP	PYCF	PYCP	PSPBT	PSPBL	PFLB
1	1.000	0.005	0.329	0.004	1.000	1.000	1.000	1.000	1.000	1.000	0.082
2	1.000	0.005	0.329	0.004	1.000	1.000	1.000	1.000	1.000	1.000	0.081
3	1.000	0.004	0.329	0.003	1.000	1.000	1.000	1.000	1.000	1.000	0.081
4	1.000	0.003	0.328	0.003	1.000	1.000	1.000	1.000	1.000	1.000	0.081
5	1.000	0.003	0.328	0.002	1.000	1.000	1.000	1.000	1.000	1.000	0.080
6	1.000	0.003	0.328	0.002	1.000	1.000	1.000	1.000	1.000	1.000	0.081
7	1.000	0.004	0.328	0.003	1.000	1.000	1.000	1.000	1.000	1.000	0.081
8	1.000	0.004	0.329	0.004	1.000	1.000	1.000	1.000	1.000	1.000	0.081
9	1.000	0.004	0.329	0.004	1.000	1.000	1.000	1.000	1.000	1.000	0.081
10	1.000	0.004	0.329	0.004	1.000	1.000	1.000	1.000	1.000	1.000	0.081
11	1.000	0.004	0.329	0.003	1.000	1.000	1.000	1.000	1.000	1.000	0.081
12	1.000	0.003	0.328	0.003	1.000	1.000	1.000	1.000	1.000	1.000	0.081
13	1.000	0.003	0.328	0.002	1.000	1.000	1.000	1.000	1.000	1.000	0.081
14	1.000	0.002	0.328	0.001	1.000	1.000	1.000	1.000	1.000	1.000	0.080
15	1.000	0.003	0.328	0.002	1.000	1.000	1.000	1.000	1.000	1.000	0.081
16	1.000	0.003	0.328	0.002	1.000	1.000	1.000	1.000	1.000	1.000	0.081
17	1.000	0.004	0.329	0.003	1.000	1.000	1.000	1.000	1.000	1.000	0.081
18	1.000	0.004	0.329	0.003	1.000	1.000	1.000	1.000	1.000	1.000	0.081

POSITIVE NUMBER: CONSTRAINT SATISFIED. | THESE VALUES ARE NORMALIZED  
 NEGATIVE NUMBER: CONSTRAINT VIOLATED. | BETWEEN +1. AND -1.  
 1.000 : CONSTRAINT NOT RELEVANT OR NULLIFIED BY USER.  
 -2.000 : CONSTRAINT SUPPRESSED.  
 -- : STRAKE NOT EVALUATED.

HYDROSTATIC TEST - CYL 1.D

=====

INITIAL PANEL ADEQUACY PARAMETER VALUES - MODULE 2 OF SUBSTR. 1

STRAKE	CCBB	CCGB	PCMY	CCLB	PYTF	PYTP	PYCF	PYCP	PSPBT	PSPBL	PFLB
1	1.000	0.005	0.329	0.004	1.000	1.000	1.000	1.000	1.000	1.000	0.082
2	1.000	0.005	0.329	0.004	1.000	1.000	1.000	1.000	1.000	1.000	0.081
3	1.000	0.004	0.329	0.003	1.000	1.000	1.000	1.000	1.000	1.000	0.081
4	1.000	0.003	0.328	0.003	1.000	1.000	1.000	1.000	1.000	1.000	0.081
5	1.000	0.003	0.328	0.002	1.000	1.000	1.000	1.000	1.000	1.000	0.080
6	1.000	0.003	0.328	0.002	1.000	1.000	1.000	1.000	1.000	1.000	0.081
7	1.000	0.004	0.328	0.003	1.000	1.000	1.000	1.000	1.000	1.000	0.081
8	1.000	0.004	0.329	0.004	1.000	1.000	1.000	1.000	1.000	1.000	0.081
9	1.000	0.004	0.329	0.004	1.000	1.000	1.000	1.000	1.000	1.000	0.081
10	1.000	0.004	0.329	0.004	1.000	1.000	1.000	1.000	1.000	1.000	0.081
11	1.000	0.004	0.329	0.003	1.000	1.000	1.000	1.000	1.000	1.000	0.081
12	1.000	0.003	0.328	0.003	1.000	1.000	1.000	1.000	1.000	1.000	0.081
13	1.000	0.003	0.328	0.002	1.000	1.000	1.000	1.000	1.000	1.000	0.081
14	1.000	0.002	0.328	0.001	1.000	1.000	1.000	1.000	1.000	1.000	0.080
15	1.000	0.003	0.328	0.002	1.000	1.000	1.000	1.000	1.000	1.000	0.081
16	1.000	0.003	0.328	0.002	1.000	1.000	1.000	1.000	1.000	1.000	0.081
17	1.000	0.004	0.329	0.003	1.000	1.000	1.000	1.000	1.000	1.000	0.081
18	1.000	0.004	0.329	0.003	1.000	1.000	1.000	1.000	1.000	1.000	0.081

POSITIVE NUMBER: CONSTRAINT SATISFIED. | THESE VALUES ARE NORMALIZED  
 NEGATIVE NUMBER: CONSTRAINT VIOLATED. | BETWEEN +1. AND -1.  
 1.000 : CONSTRAINT NOT RELEVANT OR NULLIFIED BY USER.  
 -2.000 : CONSTRAINT SUPPRESSED.  
 -- : STRAKE NOT EVALUATED.

# Numerical Solution (MAESTRO, version 8.5)

## NAVSEA Test Cylinder 1.f

### General Defintions

$E := 30000 \text{ ksi}$	Young's Modulus of Elasticity	$\text{ksi} := 6.89475710^6 \text{ Pa}$
$F_y := 98.5 \text{ ksi}$	Yield Strength	
$\nu := .3$	Poison's ratio for Fe/Steel	
$t := 0.263 \text{ in}$	thickness of shell	
$R_i := 17.197 \text{ in}$	Inner radius of cylinder	
$D_0 := 2 \cdot (R_i + t)$	diameter to outside of shell	$D_0 = 34.92 \text{ in}$
$L_r := 2.666 \text{ in}$	ring spacing (frame center to frame center)	
$L_b := 42.129 \text{ in}$	length of cylinder between bulkheads or lines of support	
$R := \frac{D_0}{2} - \frac{t}{2}$		
$R = 17.328 \text{ in}$	radius to centerline of shell	

### Ring Stiffener Dimensions

$t_w := 0.198 \text{ in}$	thickness of web of ring stiffener	$t_w = 0.198 \text{ in}$
$h_w := 0.762 \text{ in}$	height of web of ring stiffener	$h_w = 0.762 \text{ in}$
$b := t_w$	faying width of stiffener (from P&S for I beam stiffener)	
$b_f := 0.763 \text{ in}$	breadth of flange of ring stiffener	$b_f = 0.763 \text{ in}$
$t_f := 0.263 \text{ in}$	flange thickness of ring stiffener	$t_f = 0.263 \text{ in}$

MAESTRO Modeler representation of cylinder 1.f

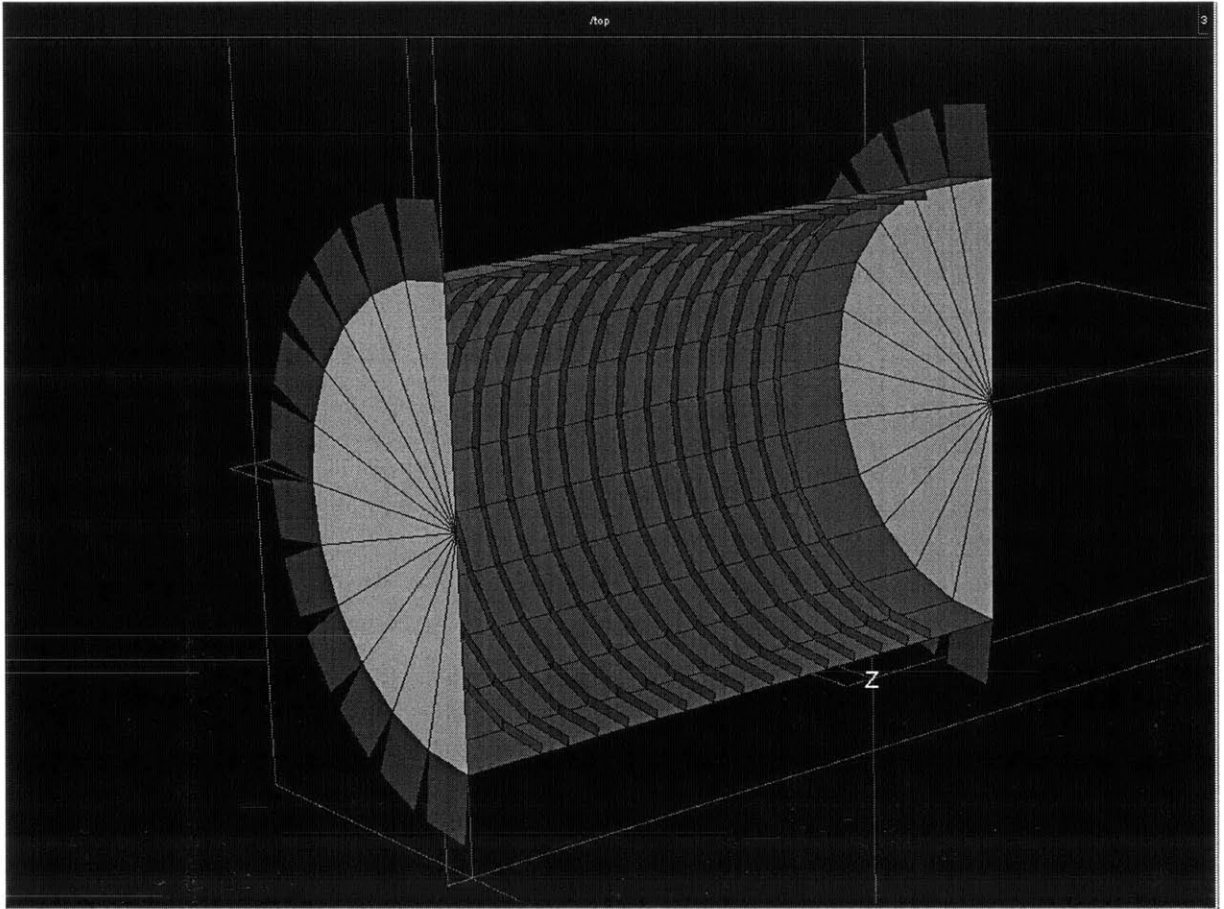

MAESTRO Version 8.5.0 27-APR-2003 PAGE 1  
 HYDROSTATIC TEST - CYL 1.F  
 =====  
 VERSION OF DATA SET IS 8.1.1

JOB TYPE: STRUCTURAL ANALYSIS  
 DEFLECTIONS TO BE SAVED ON FILE CYL 1F.DEF

STRUCTURE PARAMETERS:  
 \*\*\*\*\*

PLOT LEVEL = 2  
 TRANSVERSE SYMMETRY INDICATOR = 2  
 LEVEL OF OUTPUT REGARDING F. E. MODEL = 1  
 DEFAULT EVALUATION LEVEL = 3  
 STATION SPACING FOR PRINTING SUMMED  
 VERTICAL LOADS = 1st sectn.  
 FIRST SUBSTRUCTURE IN NODE RENUMBERING: 1  
 FIRST MODULE IN NODE RENUMBERING: 1  
 GLOBAL X VALUE FOR STATION 0: Lowest value  
 IF 1, SUPPRESS OUT-OF-PLANE DEFLECTION  
 OF UNSTIFFENED COMPOUND NODES: 0

REFERENCE	XREF.	YREF.	ZREF.	OCEAN SURFACE
REFERENCE	0.000	0.000	0.000	0.000

Module 1 of Substructure 1

DATA GROUP IV(A) - DEFINITION OF STRAKES

TYPE	STRAKE	ENDPOINT NUMBERS		MATERIAL TYPE			EFFECT. SPAN	PANEL TYPE	RADIUS OR REF. STRAKE	FRAME WEB ANGLE	LOAD ALLOCATION OR		EVAL. LEVEL
		EDGE 1	EDGE 2	PLT	STIFF	FRM					OPP. R	SEC/BAY	
BOTTOM	1	1	2	1	1	1	6.48	LCYL	H+1.49E-01	+X TRANS	H+1.49E-01	0	3
BOTTOM	2	2	3	1	1	1	6.48	LCYL	H+1.49E-01	+X TRANS	H+1.49E-01	0	3
BOTTOM	3	3	4	1	1	1	6.48	LCYL	H+1.49E-01	+X TRANS	H+1.49E-01	0	3
BOTTOM	4	4	5	1	1	1	6.48	LCYL	H+1.49E-01	+X TRANS	H+1.49E-01	0	3
BOTTOM	5	5	6	1	1	1	6.48	LCYL	H+1.49E-01	+X TRANS	H+1.49E-01	0	3
BOTTOM	6	6	7	1	1	1	6.48	LCYL	H+1.49E-01	+X TRANS	H+1.49E-01	0	3
BOTTOM	7	7	8	1	1	1	6.48	LCYL	H+1.49E-01	+X TRANS	H+1.49E-01	0	3
BOTTOM	8	8	9	1	1	1	6.48	LCYL	H+1.49E-01	+X TRANS	H+1.49E-01	0	3
BOTTOM	9	9	10	1	1	1	6.48	LCYL	H+1.49E-01	+X TRANS	H+1.49E-01	0	3
BOTTOM	10	10	11	1	1	1	6.48	LCYL	H+1.49E-01	+X TRANS	H+1.49E-01	0	3
BOTTOM	11	11	12	1	1	1	6.48	LCYL	H+1.49E-01	+X TRANS	H+1.49E-01	0	3
BOTTOM	12	12	13	1	1	1	6.48	LCYL	H+1.49E-01	+X TRANS	H+1.49E-01	0	3

ENDCOMP

1

MAESTRO Version 8.5.0 ANALYSIS JOB  
HYDROSTATIC TEST - CYL 1.F

27-APR-2003 PAGE 4

GROUP VI(B) - SHELL TRIANGLE ELEMENTS

LABEL OR SEQ. NO.	NODE 1 ENPT	NODE 1 SEC	NODE 2 ENPT	NODE 2 SEC	NODE 3 ENPT	NODE 3 SEC	MATL. TYPE	PLATE THICK.	PANEL CODE	H.G. EFF.
T1	1	0	-1	0	2	0	1	4.00	W	
T2	2	0	-1	0	3	0	1	4.00	W	
T3	3	0	-1	0	4	0	1	4.00	W	
T4	4	0	-1	0	5	0	1	4.00	W	
T5	5	0	-1	0	6	0	1	4.00	W	
T6	6	0	-1	0	7	0	1	4.00	W	
T7	7	0	-1	0	8	0	1	4.00	W	
T8	8	0	-1	0	9	0	1	4.00	W	
T9	9	0	-1	0	10	0	1	4.00	W	
T10	10	0	-1	0	11	0	1	4.00	W	
T11	11	0	-1	0	12	0	1	4.00	W	
T12	12	0	-1	0	13	0	1	4.00	W	

Module 2 of Substructure 1  
 DATA GROUP IV(A) - DEFINITION OF STRAKES

TYPE	STRAKE	ENDPOINT NUMBERS		MATERIAL TYPE			EFFECT. SPAN	PANEL TYPE	RADIUS OR REF. STRAKE	FRAME WEB ANGLE	LOAD ALLOCATION		EVAL. LEVEL
		EDGE 1	EDGE 2	PLT	STIFF	FRM					OPP. R & SEC/BAY	OR	
BOTTOM	1	1	2	1	1	1	2.62	LCYL	H+1.49E-01	-X TRANS	H+1.49E-01	0	3
BOTTOM	2	2	3	1	1	1	2.62	LCYL	H+1.49E-01	-X TRANS	H+1.49E-01	0	3
BOTTOM	3	3	4	1	1	1	2.62	LCYL	H+1.49E-01	-X TRANS	H+1.49E-01	0	3
BOTTOM	4	4	5	1	1	1	2.62	LCYL	H+1.49E-01	-X TRANS	H+1.49E-01	0	3
BOTTOM	5	5	6	1	1	1	2.62	LCYL	H+1.49E-01	-X TRANS	H+1.49E-01	0	3
BOTTOM	6	6	7	1	1	1	2.62	LCYL	H+1.49E-01	-X TRANS	H+1.49E-01	0	3
BOTTOM	7	7	8	1	1	1	2.62	LCYL	H+1.49E-01	-X TRANS	H+1.49E-01	0	3
BOTTOM	8	8	9	1	1	1	2.62	LCYL	H+1.49E-01	-X TRANS	H+1.49E-01	0	3
BOTTOM	9	9	10	1	1	1	2.62	LCYL	H+1.49E-01	-X TRANS	H+1.49E-01	0	3
BOTTOM	10	10	11	1	1	1	2.62	LCYL	H+1.49E-01	-X TRANS	H+1.49E-01	0	3
BOTTOM	11	11	12	1	1	1	2.62	LCYL	H+1.49E-01	-X TRANS	H+1.49E-01	0	3
BOTTOM	12	12	13	1	1	1	2.62	LCYL	H+1.49E-01	-X TRANS	H+1.49E-01	0	3

END

ENDCOMP

GROUP VI(B) - SHELL TRIANGLE ELEMENTS

LABEL OR SEQ. NO.	NODE 1 ENPT SEC	NODE 2 ENPT SEC	NODE 3 ENPT SEC	MATL. TYPE	PLATE THICK.	PANEL CODE	H.G. EFF.
----------------------	--------------------	--------------------	--------------------	---------------	-----------------	---------------	--------------

Module 3 of Substructure 1  
 DATA GROUP IV(A) - DEFINITION OF STRAKES

TYPE	STRAKE	ENDPOINT NUMBERS		MATERIAL TYPE			EFFECT. SPAN	PANEL TYPE	RADIUS OR REF. STRAKE	FRAME WEB ANGLE	LOAD ALLOCATION OR		EVAL. LEVEL
		EDGE 1	EDGE 2	PLT	STIFF	FRM					OPP. R	SEC/BAY	
BOTTOM	1	1	2	1	1	1	2.65	LCYL	H+1.49E-01	-X TRANS	H+1.49E-01	0	3
BOTTOM	2	2	3	1	1	1	2.65	LCYL	H+1.49E-01	-X TRANS	H+1.49E-01	0	3
BOTTOM	3	3	4	1	1	1	2.65	LCYL	H+1.49E-01	-X TRANS	H+1.49E-01	0	3
BOTTOM	4	4	5	1	1	1	2.65	LCYL	H+1.49E-01	-X TRANS	H+1.49E-01	0	3
BOTTOM	5	5	6	1	1	1	2.65	LCYL	H+1.49E-01	-X TRANS	H+1.49E-01	0	3
BOTTOM	6	6	7	1	1	1	2.65	LCYL	H+1.49E-01	-X TRANS	H+1.49E-01	0	3
BOTTOM	7	7	8	1	1	1	2.65	LCYL	H+1.49E-01	-X TRANS	H+1.49E-01	0	3
BOTTOM	8	8	9	1	1	1	2.65	LCYL	H+1.49E-01	-X TRANS	H+1.49E-01	0	3
BOTTOM	9	9	10	1	1	1	2.65	LCYL	H+1.49E-01	-X TRANS	H+1.49E-01	0	3
BOTTOM	10	10	11	1	1	1	2.65	LCYL	H+1.49E-01	-X TRANS	H+1.49E-01	0	3
BOTTOM	11	11	12	1	1	1	2.65	LCYL	H+1.49E-01	-X TRANS	H+1.49E-01	0	3
BOTTOM	12	12	13	1	1	1	2.65	LCYL	H+1.49E-01	-X TRANS	H+1.49E-01	0	3

END

ENDCOMP

GROUP VI(B) - SHELL TRIANGLE ELEMENTS

LABEL OR SEQ. NO.	NODE 1 ENPT	NODE 2 SEC ENPT	NODE 3 SEC ENPT	MATL. TYPE	PLATE THICK.	PANEL CODE	H.G. EFF.
----------------------	----------------	--------------------	--------------------	---------------	-----------------	---------------	--------------

Module 4 of Substructure 1  
 DATA GROUP IV(A) - DEFINITION OF STRAKES

TYPE	STRAKE	ENDPOINT NUMBERS		MATERIAL TYPE			EFFECT. SPAN	PANEL TYPE	RADIUS OR REF. STRAKE	FRAME WEB ANGLE	LOAD ALLOCATION		EVAL. LEVEL
		EDGE 1	EDGE 2	PLT	STIFF	FRM					OPP. R &	SEC/BAY	
BOTTOM	1	1	2	1	1	1	6.74	LCYL	H+1.49E-01	+X TRANS	H+1.49E-01	0	3
BOTTOM	2	2	3	1	1	1	6.74	LCYL	H+1.49E-01	+X TRANS	H+1.49E-01	0	3
BOTTOM	3	3	4	1	1	1	6.74	LCYL	H+1.49E-01	+X TRANS	H+1.49E-01	0	3
BOTTOM	4	4	5	1	1	1	6.74	LCYL	H+1.49E-01	+X TRANS	H+1.49E-01	0	3
BOTTOM	5	5	6	1	1	1	6.74	LCYL	H+1.49E-01	+X TRANS	H+1.49E-01	0	3
BOTTOM	6	6	7	1	1	1	6.74	LCYL	H+1.49E-01	+X TRANS	H+1.49E-01	0	3
BOTTOM	7	7	8	1	1	1	6.74	LCYL	H+1.49E-01	+X TRANS	H+1.49E-01	0	3
BOTTOM	8	8	9	1	1	1	6.74	LCYL	H+1.49E-01	+X TRANS	H+1.49E-01	0	3
BOTTOM	9	9	10	1	1	1	6.74	LCYL	H+1.49E-01	+X TRANS	H+1.49E-01	0	3
BOTTOM	10	10	11	1	1	1	6.74	LCYL	H+1.49E-01	+X TRANS	H+1.49E-01	0	3
BOTTOM	11	11	12	1	1	1	6.74	LCYL	H+1.49E-01	+X TRANS	H+1.49E-01	0	3
BOTTOM	12	12	13	1	1	1	6.74	LCYL	H+1.49E-01	+X TRANS	H+1.49E-01	0	3
END													

ENDCOMP

1

GROUP VI(B) - SHELL TRIANGLE ELEMENTS

LABEL OR SEQ. NO.	NODE 1		NODE 2		NODE 3		MATL. TYPE	PLATE THICK.	PANEL CODE	H.G. EFF.
	ENPT	SEC	ENPT	SEC	ENPT	SEC				
T1	2	1	-1	0	1	1	1	4.00	W	
T2	3	1	-1	0	2	1	1	4.00	W	
T3	4	1	-1	0	3	1	1	4.00	W	
T4	5	1	-1	0	4	1	1	4.00	W	
T5	6	1	-1	0	5	1	1	4.00	W	
T6	7	1	-1	0	6	1	1	4.00	W	
T7	8	1	-1	0	7	1	1	4.00	W	
T8	9	1	-1	0	8	1	1	4.00	W	
T9	10	1	-1	0	9	1	1	4.00	W	
T10	11	1	-1	0	10	1	1	4.00	W	
T11	12	1	-1	0	11	1	1	4.00	W	
T12	13	1	-1	0	12	1	1	4.00	W	



**LOAD CASE: HYDROSTATIC PRESSURE – 1920 PSI**

HYDROSTATIC TEST - CYL 1.F

=====

INITIAL PANEL ADEQUACY PARAMETER VALUES - MODULE 1 OF SUBSTR. 1

STRAKE	CCBB	CCGB	PCMY	CCLB	PYTF	PYTP	PYCF	PYCP	PSPBT	PSPBL	PFLB
1	1.000	1.000	0.266	0.287	1.000	1.000	1.000	1.000	1.000	1.000	0.078
2	1.000	1.000	0.266	0.287	1.000	1.000	1.000	1.000	1.000	1.000	0.078
3	1.000	1.000	0.266	0.287	1.000	1.000	1.000	1.000	1.000	1.000	0.078
4	1.000	1.000	0.266	0.287	1.000	1.000	1.000	1.000	1.000	1.000	0.078
5	1.000	1.000	0.266	0.287	1.000	1.000	1.000	1.000	1.000	1.000	0.078
6	1.000	1.000	0.266	0.287	1.000	1.000	1.000	1.000	1.000	1.000	0.078
7	1.000	1.000	0.266	0.287	1.000	1.000	1.000	1.000	1.000	1.000	0.078
8	1.000	1.000	0.266	0.287	1.000	1.000	1.000	1.000	1.000	1.000	0.078
9	1.000	1.000	0.266	0.287	1.000	1.000	1.000	1.000	1.000	1.000	0.078
10	1.000	1.000	0.266	0.287	1.000	1.000	1.000	1.000	1.000	1.000	0.078
11	1.000	1.000	0.266	0.287	1.000	1.000	1.000	1.000	1.000	1.000	0.078
12	1.000	1.000	0.266	0.287	1.000	1.000	1.000	1.000	1.000	1.000	0.078

POSITIVE NUMBER: CONSTRAINT SATISFIED. | THESE VALUES ARE NORMALIZED  
 NEGATIVE NUMBER: CONSTRAINT VIOLATED. | BETWEEN +1. AND -1.  
 1.000 : CONSTRAINT NOT RELEVANT OR NULLIFIED BY USER.  
 -2.000 : CONSTRAINT SUPPRESSED.  
 -- : STRAKE NOT EVALUATED.

HYDROSTATIC TEST - CYL 1.F

=====

INITIAL PANEL ADEQUACY PARAMETER VALUES - MODULE 2 OF SUBSTR. 1

STRAKE	CCBB	CCGB	PCMY	CCLB	PYTF	PYTP	PYCF	PYCP	PSPBT	PSPBL	PFLB
1	1.000	0.014	-0.018	0.265	1.000	1.000	1.000	1.000	1.000	1.000	-0.126
2	1.000	0.014	-0.018	0.265	1.000	1.000	1.000	1.000	1.000	1.000	-0.126
3	1.000	0.014	-0.018	0.265	1.000	1.000	1.000	1.000	1.000	1.000	-0.126
4	1.000	0.014	-0.018	0.265	1.000	1.000	1.000	1.000	1.000	1.000	-0.126
5	1.000	0.014	-0.018	0.265	1.000	1.000	1.000	1.000	1.000	1.000	-0.126
6	1.000	0.014	-0.018	0.265	1.000	1.000	1.000	1.000	1.000	1.000	-0.126
7	1.000	0.014	-0.018	0.264	1.000	1.000	1.000	1.000	1.000	1.000	-0.126
8	1.000	0.014	-0.018	0.264	1.000	1.000	1.000	1.000	1.000	1.000	-0.126
9	1.000	0.014	-0.018	0.264	1.000	1.000	1.000	1.000	1.000	1.000	-0.127
10	1.000	0.014	-0.018	0.264	1.000	1.000	1.000	1.000	1.000	1.000	-0.127
11	1.000	0.014	-0.018	0.264	1.000	1.000	1.000	1.000	1.000	1.000	-0.127
12	1.000	0.014	-0.018	0.264	1.000	1.000	1.000	1.000	1.000	1.000	-0.127

POSITIVE NUMBER: CONSTRAINT SATISFIED. | THESE VALUES ARE NORMALIZED  
 NEGATIVE NUMBER: CONSTRAINT VIOLATED. | BETWEEN +1. AND -1.  
 1.000 : CONSTRAINT NOT RELEVANT OR NULLIFIED BY USER.  
 -2.000 : CONSTRAINT SUPPRESSED.  
 -- : STRAKE NOT EVALUATED.

HYDROSTATIC TEST - CYL 1.F

=====

INITIAL PANEL ADEQUACY PARAMETER VALUES - MODULE 3 OF SUBSTR. 1

-----

STRAKE	CCBB	CCGB	PCMY	CCLB	PYTF	PYTP	PYCF	PYCP	PSPBT	PSPBL	PFLB
1	1.000	0.001	-0.026	0.248	1.000	1.000	1.000	1.000	1.000	1.000	-0.134
2	1.000	0.000	-0.026	0.248	1.000	1.000	1.000	1.000	1.000	1.000	-0.134
3	1.000	0.000	-0.026	0.248	1.000	1.000	1.000	1.000	1.000	1.000	-0.134
4	1.000	0.000	-0.026	0.248	1.000	1.000	1.000	1.000	1.000	1.000	-0.134
5	1.000	0.000	-0.026	0.248	1.000	1.000	1.000	1.000	1.000	1.000	-0.134
6	1.000	0.000	-0.026	0.247	1.000	1.000	1.000	1.000	1.000	1.000	-0.134
7	1.000	0.000	-0.026	0.247	1.000	1.000	1.000	1.000	1.000	1.000	-0.134
8	1.000	0.000	-0.026	0.247	1.000	1.000	1.000	1.000	1.000	1.000	-0.134
9	1.000	0.000	-0.026	0.247	1.000	1.000	1.000	1.000	1.000	1.000	-0.134
10	1.000	0.000	-0.026	0.247	1.000	1.000	1.000	1.000	1.000	1.000	-0.135
11	1.000	0.000	-0.026	0.247	1.000	1.000	1.000	1.000	1.000	1.000	-0.135
12	1.000	0.000	-0.026	0.247	1.000	1.000	1.000	1.000	1.000	1.000	-0.135

POSITIVE NUMBER: CONSTRAINT SATISFIED. | THESE VALUES ARE NORMALIZED  
 NEGATIVE NUMBER: CONSTRAINT VIOLATED. | BETWEEN +1. AND -1.  
 1.000 : CONSTRAINT NOT RELEVANT OR NULLIFIED BY USER.  
 -2.000 : CONSTRAINT SUPPRESSED.  
 -- : STRAKE NOT EVALUATED.

HYDROSTATIC TEST - CYL 1.F

=====

INITIAL PANEL ADEQUACY PARAMETER VALUES - MODULE 4 OF SUBSTR. 1

STRAKE	CCBB	CCGB	PCMY	CCLB	PYTF	PYTP	PYCF	PYCP	PSPBT	PSPBL	PFLB
1	1.000	1.000	0.268	0.295	1.000	1.000	1.000	1.000	1.000	1.000	0.078
2	1.000	1.000	0.268	0.295	1.000	1.000	1.000	1.000	1.000	1.000	0.078
3	1.000	1.000	0.268	0.295	1.000	1.000	1.000	1.000	1.000	1.000	0.078
4	1.000	1.000	0.268	0.294	1.000	1.000	1.000	1.000	1.000	1.000	0.078
5	1.000	1.000	0.268	0.294	1.000	1.000	1.000	1.000	1.000	1.000	0.078
6	1.000	1.000	0.268	0.294	1.000	1.000	1.000	1.000	1.000	1.000	0.078
7	1.000	1.000	0.267	0.294	1.000	1.000	1.000	1.000	1.000	1.000	0.078
8	1.000	1.000	0.267	0.294	1.000	1.000	1.000	1.000	1.000	1.000	0.078
9	1.000	1.000	0.267	0.294	1.000	1.000	1.000	1.000	1.000	1.000	0.078
10	1.000	1.000	0.267	0.294	1.000	1.000	1.000	1.000	1.000	1.000	0.078
11	1.000	1.000	0.267	0.294	1.000	1.000	1.000	1.000	1.000	1.000	0.078
12	1.000	1.000	0.267	0.294	1.000	1.000	1.000	1.000	1.000	1.000	0.078

POSITIVE NUMBER: CONSTRAINT SATISFIED. | THESE VALUES ARE NORMALIZED  
 NEGATIVE NUMBER: CONSTRAINT VIOLATED. | BETWEEN +1. AND -1.  
 1.000 : CONSTRAINT NOT RELEVANT OR NULLIFIED BY USER.  
 -2.000 : CONSTRAINT SUPPRESSED.  
 -- : STRAKE NOT EVALUATED.

# Numerical Solution (MAESTRO, version 8.5)

## NAVSEA Test Cylinder 2.a

### General Defintions

$E := 30000 \text{ ksi}$	Young's Modulus of Elasticity	$\text{ksi} := 6.89475710^6 \text{ Pa}$
$F_y := 65.5 \text{ ksi}$	Yield Strength	
$\nu := .3$	Poison's ratio for Fe/Steel	
$t := 0.0858 \text{ in}$	thickness of shell	
$R_i := 8.375 \text{ in}$	Inner radius of cylinder	
$D_0 := 2 \cdot (R_i + t)$	diameter to outside of shell	$D_0 = 16.922 \text{ in}$
$L_r := 1.366 \text{ in}$	ring spacing (frame center to frame center)	
$L_b := 8.636 \text{ in}$	length of cylinder between bulkheads or lines of support	
$R := \frac{D_0}{2} - \frac{t}{2}$		
$R = 8.418 \text{ in}$	radius to centerline of shell	

### Ring Stiffener Dimensions

$t_w := 0.044 \text{ in}$	thickness of web of ring stiffener	$t_w = 0.044 \text{ in}$
$h_w := 0.4539 \text{ in}$	height of web of ring stiffener	$h_w = 0.454 \text{ in}$
$b := t_w$	faying width of stiffener (from P&S for I beam stiffener)	
$b_f := 0.399 \text{ in}$	breadth of flange of ring stiffener	$b_f = 0.399 \text{ in}$
$t_f := 0.078 \text{ in}$	flange thickness of ring stiffener	$t_f = 0.078 \text{ in}$

MAESTRO Modeler representation of cylinder 2.a

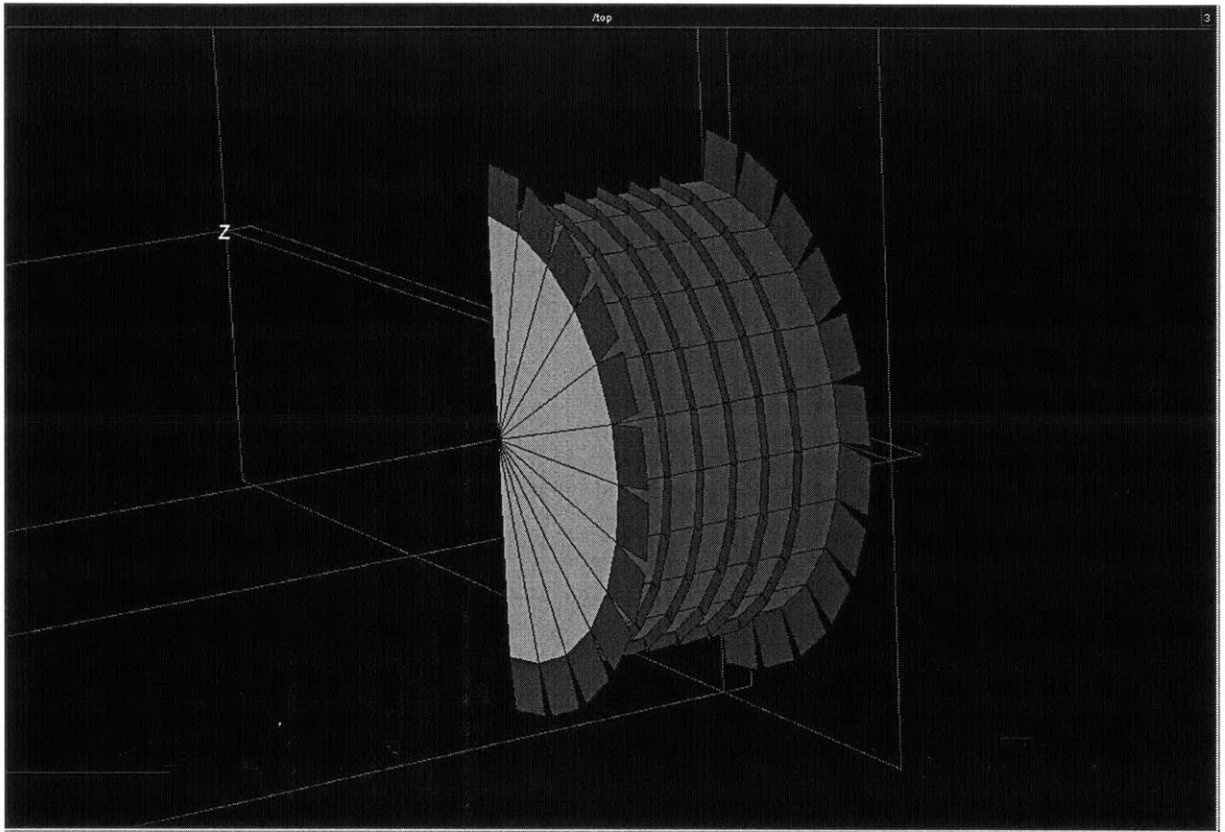

MAESTRO Version 8.5.0 12-APR-2003 PAGE 1

HYDROSTATIC TEST - CYL 2.A

=====

VERSION OF DATA SET IS 8.1.1

JOB TYPE: STRUCTURAL ANALYSIS  
 DEFLECTIONS TO BE SAVED ON FILE CYL 2A.DEF

STRUCTURE PARAMETERS:  
 \*\*\*\*\*

PLOT LEVEL =	2
TRANSVERSE SYMMETRY INDICATOR =	2
LEVEL OF OUTPUT REGARDING F. E. MODEL =	1
DEFAULT EVALUATION LEVEL =	3
STATION SPACING FOR PRINTING SUMMED	
VERTICAL LOADS =	1st sectn.
FIRST SUBSTRUCTURE IN NODE RENUMBERING:	1
FIRST MODULE IN NODE RENUMBERING:	1
GLOBAL X VALUE FOR STATION 0:	Lowest value
IF 1, SUPPRESS OUT-OF-PLANE DEFLECTION	
OF UNSTIFFENED COMPOUND NODES:	0

REFERENCE COORDINATES OF STRUCTURE ORIGIN AND OCEAN SURFACE				
KEYWORD	XREF.	YREF.	ZREF.	OCEAN SURFACE
REFERENCE	0.000	0.000	0.000	0.000

Module 1 of Substructure 1  
 DATA GROUP IV(A) - DEFINITION OF STRAKES

TYPE	STRAKE	ENDPOINT NUMBERS		MATERIAL TYPE			EFFECT. SPAN	PANEL TYPE	RADIUS OR REF. STRAKE	FRAME WEB ANGLE	LOAD ALLOCATION OR		EVAL. LEVEL
		EDGE 1	EDGE 2	PLT	STIFF	FRM					OPP. R	SEC/BAY	
BOTTOM	1	1	2	1	1	1	1.90	LCYL	H+7.20E-02	+X TRANS	H+7.20E-02	0	3
BOTTOM	2	2	3	1	1	1	1.90	LCYL	H+7.20E-02	+X TRANS	H+7.20E-02	0	3
BOTTOM	3	3	4	1	1	1	1.90	LCYL	H+7.20E-02	+X TRANS	H+7.20E-02	0	3
BOTTOM	4	4	5	1	1	1	1.90	LCYL	H+7.20E-02	+X TRANS	H+7.20E-02	0	3
BOTTOM	5	5	6	1	1	1	1.90	LCYL	H+7.20E-02	+X TRANS	H+7.20E-02	0	3
BOTTOM	6	6	7	1	1	1	1.90	LCYL	H+7.20E-02	+X TRANS	H+7.20E-02	0	3
BOTTOM	7	7	8	1	1	1	1.90	LCYL	H+7.20E-02	+X TRANS	H+7.20E-02	0	3
BOTTOM	8	8	9	1	1	1	1.90	LCYL	H+7.20E-02	+X TRANS	H+7.20E-02	0	3
BOTTOM	9	9	10	1	1	1	1.90	LCYL	H+7.20E-02	+X TRANS	H+7.20E-02	0	3
BOTTOM	10	10	11	1	1	1	1.90	LCYL	H+7.20E-02	+X TRANS	H+7.20E-02	0	3
BOTTOM	11	11	12	1	1	1	1.90	LCYL	H+7.20E-02	+X TRANS	H+7.20E-02	0	3
BOTTOM	12	12	13	1	1	1	1.90	LCYL	H+7.20E-02	+X TRANS	H+7.20E-02	0	3

ENDCOMP

1

GROUP VI(B) - SHELL TRIANGLE ELEMENTS

LABEL OR SEQ. NO.	NODE 1		NODE 2		NODE 3		MATL. TYPE	PLATE THICK.	PANEL CODE	H.G. EFF.
	ENPT	SEC	ENPT	SEC	ENPT	SEC				
T1	1	0	-1	0	2	0	1	3.00	W	
T2	2	0	-1	0	3	0	1	3.00	W	
T3	3	0	-1	0	4	0	1	3.00	W	
T4	4	0	-1	0	5	0	1	3.00	W	
T5	5	0	-1	0	6	0	1	3.00	W	
T6	6	0	-1	0	7	0	1	3.00	W	
T7	7	0	-1	0	8	0	1	3.00	W	
T8	8	0	-1	0	9	0	1	3.00	W	
T9	9	0	-1	0	10	0	1	3.00	W	
T10	10	0	-1	0	11	0	1	3.00	W	
T11	11	0	-1	0	12	0	1	3.00	W	
T12	12	0	-1	0	13	0	1	3.00	W	

Module 2 of Substructure 1  
 DATA GROUP IV(A) - DEFINITION OF STRAKES

TYPE	STRAKE	ENDPOINT NUMBERS		MATERIAL TYPE			EFFECT. SPAN	PANEL TYPE	RADIUS OR REF. STRAKE	FRAME WEB ANGLE	LOAD ALLOCATION		EVAL. LEVEL
		EDGE 1	EDGE 2	PLT	STIFF	FRM					OPP. R &	SEC/BAY	
BOTTOM	1	1	2	1	1	1	1.37	LCYL	H+7.20E-02	+X TRANS	H+7.20E-02	0	3
BOTTOM	2	2	3	1	1	1	1.37	LCYL	H+7.20E-02	+X TRANS	H+7.20E-02	0	3
BOTTOM	3	3	4	1	1	1	1.37	LCYL	H+7.20E-02	+X TRANS	H+7.20E-02	0	3
BOTTOM	4	4	5	1	1	1	1.37	LCYL	H+7.20E-02	+X TRANS	H+7.20E-02	0	3
BOTTOM	5	5	6	1	1	1	1.37	LCYL	H+7.20E-02	+X TRANS	H+7.20E-02	0	3
BOTTOM	6	6	7	1	1	1	1.37	LCYL	H+7.20E-02	+X TRANS	H+7.20E-02	0	3
BOTTOM	7	7	8	1	1	1	1.37	LCYL	H+7.20E-02	+X TRANS	H+7.20E-02	0	3
BOTTOM	8	8	9	1	1	1	1.37	LCYL	H+7.20E-02	+X TRANS	H+7.20E-02	0	3
BOTTOM	9	9	10	1	1	1	1.37	LCYL	H+7.20E-02	+X TRANS	H+7.20E-02	0	3
BOTTOM	10	10	11	1	1	1	1.37	LCYL	H+7.20E-02	+X TRANS	H+7.20E-02	0	3
BOTTOM	11	11	12	1	1	1	1.37	LCYL	H+7.20E-02	+X TRANS	H+7.20E-02	0	3
BOTTOM	12	12	13	1	1	1	1.37	LCYL	H+7.20E-02	+X TRANS	H+7.20E-02	0	3
END													

ENDCOMP

GROUP VI(B) - SHELL TRIANGLE ELEMENTS

LABEL OR SEQ. NO.	NODE 1 ENPT SEC	NODE 2 ENPT SEC	NODE 3 ENPT SEC	MATL. TYPE	PLATE THICK.	PANEL CODE	H.G. EFF.
----------------------	--------------------	--------------------	--------------------	---------------	-----------------	---------------	--------------



Module 3 of Substructure 1  
 DATA GROUP IV(A) - DEFINITION OF STRAKES

TYPE	STRAKE	ENDPOINT NUMBERS		MATERIAL TYPE			EFFECT. SPAN	PANEL TYPE	RADIUS OR REF. STRAKE	FRAME WEB ANGLE	LOAD ALLOCATION OR		EVAL. LEVEL
		EDGE 1	EDGE 2	PLT	STIFF	FRM					OPP. R & SEC/BAY		
BOTTOM	1	1	2	1	1	1	1.90	LCYL	H+7.20E-02	+X TRANS	H+7.20E-02	0	3
BOTTOM	2	2	3	1	1	1	1.90	LCYL	H+7.20E-02	+X TRANS	H+7.20E-02	0	3
BOTTOM	3	3	4	1	1	1	1.90	LCYL	H+7.20E-02	+X TRANS	H+7.20E-02	0	3
BOTTOM	4	4	5	1	1	1	1.90	LCYL	H+7.20E-02	+X TRANS	H+7.20E-02	0	3
BOTTOM	5	5	6	1	1	1	1.90	LCYL	H+7.20E-02	+X TRANS	H+7.20E-02	0	3
BOTTOM	6	6	7	1	1	1	1.90	LCYL	H+7.20E-02	+X TRANS	H+7.20E-02	0	3
BOTTOM	7	7	8	1	1	1	1.90	LCYL	H+7.20E-02	+X TRANS	H+7.20E-02	0	3
BOTTOM	8	8	9	1	1	1	1.90	LCYL	H+7.20E-02	+X TRANS	H+7.20E-02	0	3
BOTTOM	9	9	10	1	1	1	1.90	LCYL	H+7.20E-02	+X TRANS	H+7.20E-02	0	3
BOTTOM	10	10	11	1	1	1	1.90	LCYL	H+7.20E-02	+X TRANS	H+7.20E-02	0	3
BOTTOM	11	11	12	1	1	1	1.90	LCYL	H+7.20E-02	+X TRANS	H+7.20E-02	0	3
BOTTOM	12	12	13	1	1	1	1.90	LCYL	H+7.20E-02	+X TRANS	H+7.20E-02	0	3

END

ENDCOMP

GROUP VI(B) - SHELL TRIANGLE ELEMENTS

LABEL OR SEQ. NO.	NODE 1		NODE 2		NODE 3		MATL. TYPE	PLATE THICK.	PANEL CODE	H.G. EFF.
	ENPT	SEC	ENPT	SEC	ENPT	SEC				
T1	2	1	-1	0	1	1	1	3.00	W	
T2	3	1	-1	0	2	1	1	3.00	W	
T3	4	1	-1	0	3	1	1	3.00	W	
T4	5	1	-1	0	4	1	1	3.00	W	
T5	6	1	-1	0	5	1	1	3.00	W	
T6	7	1	-1	0	6	1	1	3.00	W	
T7	8	1	-1	0	7	1	1	3.00	W	
T8	9	1	-1	0	8	1	1	3.00	W	
T9	10	1	-1	0	9	1	1	3.00	W	
T10	11	1	-1	0	10	1	1	3.00	W	
T11	12	1	-1	0	11	1	1	3.00	W	
T12	13	1	-1	0	12	1	1	3.00	W	

**LOAD CASE: HYDROSTATIC PRESSURE - 797 PSI**

HYDROSTATIC TEST - CYL 2.A

=====

INITIAL PANEL ADEQUACY PARAMETER VALUES - MODULE 1 OF SUBSTR. 1

-----

STRAKE	CCBB	CCGB	PCMY	CCLB	PYTF	PYTP	PYCF	PYCP	PSPBT	PSPBL	PFLB
1	1.000	1.000	0.281	0.176	1.000	1.000	1.000	1.000	1.000	1.000	0.088
2	1.000	1.000	0.281	0.176	1.000	1.000	1.000	1.000	1.000	1.000	0.088
3	1.000	1.000	0.281	0.176	1.000	1.000	1.000	1.000	1.000	1.000	0.088
4	1.000	1.000	0.281	0.176	1.000	1.000	1.000	1.000	1.000	1.000	0.088
5	1.000	1.000	0.281	0.176	1.000	1.000	1.000	1.000	1.000	1.000	0.088
6	1.000	1.000	0.281	0.176	1.000	1.000	1.000	1.000	1.000	1.000	0.088
7	1.000	1.000	0.280	0.176	1.000	1.000	1.000	1.000	1.000	1.000	0.088
8	1.000	1.000	0.280	0.176	1.000	1.000	1.000	1.000	1.000	1.000	0.088
9	1.000	1.000	0.280	0.175	1.000	1.000	1.000	1.000	1.000	1.000	0.088
10	1.000	1.000	0.280	0.175	1.000	1.000	1.000	1.000	1.000	1.000	0.088
11	1.000	1.000	0.280	0.175	1.000	1.000	1.000	1.000	1.000	1.000	0.088
12	1.000	1.000	0.280	0.175	1.000	1.000	1.000	1.000	1.000	1.000	0.088

POSITIVE NUMBER: CONSTRAINT SATISFIED. | THESE VALUES ARE NORMALIZED  
 NEGATIVE NUMBER: CONSTRAINT VIOLATED. | BETWEEN +1. AND -1.  
 1.000 : CONSTRAINT NOT RELEVANT OR NULLIFIED BY USER.  
 -2.000 : CONSTRAINT SUPPRESSED.  
 -- : STRAKE NOT EVALUATED.

HYDROSTATIC TEST - CYL 2.A

=====

INITIAL PANEL ADEQUACY PARAMETER VALUES - MODULE 2 OF SUBSTR. 1

S'TRAKE	CCBB	CCGB	PCMY	CCLB	PYTF	PYTP	PYCF	PYCP	PSPBT	PSPBL	PFLB
1	1.000	0.054	0.073	0.003	1.000	1.000	1.000	1.000	1.000	1.000	-0.067
2	1.000	0.054	0.073	0.003	1.000	1.000	1.000	1.000	1.000	1.000	-0.067
3	1.000	0.054	0.073	0.003	1.000	1.000	1.000	1.000	1.000	1.000	-0.067
4	1.000	0.054	0.073	0.003	1.000	1.000	1.000	1.000	1.000	1.000	-0.067
5	1.000	0.054	0.073	0.003	1.000	1.000	1.000	1.000	1.000	1.000	-0.067
6	1.000	0.054	0.073	0.003	1.000	1.000	1.000	1.000	1.000	1.000	-0.067
7	1.000	0.054	0.073	0.002	1.000	1.000	1.000	1.000	1.000	1.000	-0.067
8	1.000	0.054	0.073	0.002	1.000	1.000	1.000	1.000	1.000	1.000	-0.067
9	1.000	0.053	0.073	0.002	1.000	1.000	1.000	1.000	1.000	1.000	-0.067
10	1.000	0.053	0.073	0.002	1.000	1.000	1.000	1.000	1.000	1.000	-0.067
11	1.000	0.053	0.073	0.002	1.000	1.000	1.000	1.000	1.000	1.000	-0.067
12	1.000	0.053	0.073	0.002	1.000	1.000	1.000	1.000	1.000	1.000	-0.067

POSITIVE NUMBER: CONSTRAINT SATISFIED. | THESE VALUES ARE NORMALIZED  
 NEGATIVE NUMBER: CONSTRAINT VIOLATED. | BETWEEN +1. AND -1.  
 1.000 : CONSTRAINT NOT RELEVANT OR NULLIFIED BY USER.  
 -2.000 : CONSTRAINT SUPPRESSED.  
 -- : STRAKE NOT EVALUATED.

HYDROSTATIC TEST - CYL 2.A

=====

INITIAL PANEL ADEQUACY PARAMETER VALUES - MODULE 3 OF SUBSTR. 1

STRAKE	CCBB	CCGB	PCMY	CCLB	PYTF	PYTP	PYCF	PYCP	PSPBT	PSPBL	PFLB
1	1.000	1.000	0.281	0.176	1.000	1.000	1.000	1.000	1.000	1.000	0.088
2	1.000	1.000	0.281	0.176	1.000	1.000	1.000	1.000	1.000	1.000	0.088
3	1.000	1.000	0.281	0.176	1.000	1.000	1.000	1.000	1.000	1.000	0.088
4	1.000	1.000	0.281	0.176	1.000	1.000	1.000	1.000	1.000	1.000	0.088
5	1.000	1.000	0.281	0.176	1.000	1.000	1.000	1.000	1.000	1.000	0.088
6	1.000	1.000	0.281	0.176	1.000	1.000	1.000	1.000	1.000	1.000	0.088
7	1.000	1.000	0.280	0.176	1.000	1.000	1.000	1.000	1.000	1.000	0.088
8	1.000	1.000	0.280	0.176	1.000	1.000	1.000	1.000	1.000	1.000	0.088
9	1.000	1.000	0.280	0.175	1.000	1.000	1.000	1.000	1.000	1.000	0.088
10	1.000	1.000	0.280	0.175	1.000	1.000	1.000	1.000	1.000	1.000	0.088
11	1.000	1.000	0.280	0.175	1.000	1.000	1.000	1.000	1.000	1.000	0.088
12	1.000	1.000	0.280	0.175	1.000	1.000	1.000	1.000	1.000	1.000	0.087

POSITIVE NUMBER: CONSTRAINT SATISFIED. | THESE VALUES ARE NORMALIZED  
 NEGATIVE NUMBER: CONSTRAINT VIOLATED. | BETWEEN +1. AND -1.  
 1.000 : CONSTRAINT NOT RELEVANT OR NULLIFIED BY USER.  
 -2.000 : CONSTRAINT SUPPRESSED.  
 -- : STRAKE NOT EVALUATED.

# Numerical Solution (MAESTRO, version 8.5)

## NAVSEA Test Cylinder 2.c

### General Defintions

$E := 30000 \text{ ksi}$	Young's Modulus of Elasticity	$\text{ksi} := 6.89475710^6 \text{ Pa}$
$F_y := 157 \text{ ksi}$	Yield Strength	
$\nu := .3$	Poison's ratio for Fe/Steel	
$t := 0.337 \text{ in}$	thickness of shell	
$R_i := 18.714 \text{ in}$	Inner radius of cylinder	
$D_0 := 2 \cdot (R_i + t)$	diameter to outside of shell	$D_0 = 38.102 \text{ in}$
$L_r := 3.256 \text{ in}$	ring spacing (frame center to frame center)	
$L_b := 115.532 \text{ in}$	length of cylinder between bulkheads or lines of support	
$R := \frac{D_0}{2} - \frac{t}{2}$		
$R = 18.883 \text{ in}$	radius to centerline of shell	

### Ring Stiffener Dimensions

$t_w := 0.127 \text{ in}$	thickness of web of ring stiffener	$t_w = 0.127 \text{ in}$
$h_w := 2.0 \text{ in}$	height of web of ring stiffener	$h_w = 2.01 \text{ in}$
$b := t_w$	faying width of stiffener (from P&S for I beam stiffener)	
$b_f := 1.552 \text{ in}$	breadth of flange of ring stiffener	$b_f = 1.552 \text{ in}$
$t_f := 0.305 \text{ in}$	flange thickness of ring stiffener	$t_f = 0.305 \text{ in}$

MAESTRO Modeler representation of cylinder 2.c

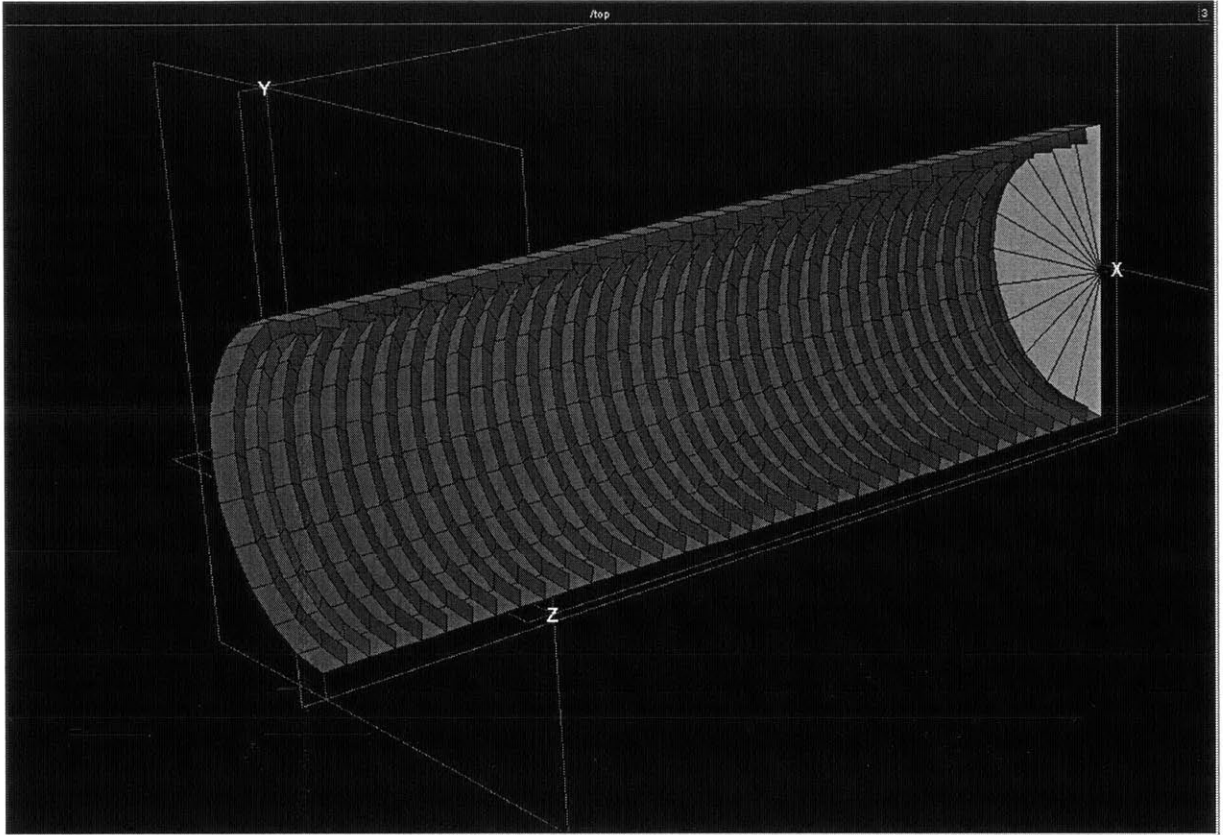

MAESTRO Version 8.5.0 12-APR-2003 PAGE 1  
 HYDROSTATIC PRESSURE - CYL 2C  
 =====

VERSION OF DATA SET IS 8.1.1

JOB TYPE: STRUCTURAL ANALYSIS  
 DEFLECTIONS TO BE SAVED ON FILE CYL 2C.DEF

STRUCTURE PARAMETERS:  
 \*\*\*\*\*

PLOT LEVEL =	2
TRANSVERSE SYMMETRY INDICATOR =	2
LEVEL OF OUTPUT REGARDING F. E. MODEL =	1
DEFAULT EVALUATION LEVEL =	3
STATION SPACING FOR PRINTING SUMMED VERTICAL LOADS =	1st sectn.
FIRST SUBSTRUCTURE IN NODE RENUMBERING:	1
FIRST MODULE IN NODE RENUMBERING:	1
GLOBAL X VALUE FOR STATION 0:	Lowest value
IF 1, SUPPRESS OUT-OF-PLANE DEFLECTION OF UNSTIFFENED COMPOUND NODES:	0

REFERENCE COORDINATES OF STRUCTURE ORIGIN AND OCEAN SURFACE				
KEYWORD	XREF.	YREF.	ZREF.	OCEAN SURFACE
REFERENCE	0.000	0.000	0.000	0.000

Module 1 of Substructure 1  
 DATA GROUP IV(A) - DEFINITION OF STRAKES

TYPE	STRAKE	ENDPOINT NUMBERS		MATERIAL TYPE			EFFECT. SPAN	PANEL TYPE	RADIUS OR REF. STRAKE	FRAME WEB ANGLE	LOAD ALLOCATION OR		EVAL. LEVEL
		EDGE 1	EDGE 2	PLT	STIFF	FRM					OPP. R	SEC/BAY	
BOTTOM	1	1	2	1	1	1	3.21	LCYL	H+1.62E-01	-X TRANS	H+1.62E-01	0	3
BOTTOM	2	2	3	1	1	1	3.21	LCYL	H+1.62E-01	-X TRANS	H+1.62E-01	0	3
BOTTOM	3	3	4	1	1	1	3.21	LCYL	H+1.62E-01	-X TRANS	H+1.62E-01	0	3
BOTTOM	4	4	5	1	1	1	3.21	LCYL	H+1.62E-01	-X TRANS	H+1.62E-01	0	3
BOTTOM	5	5	6	1	1	1	3.21	LCYL	H+1.62E-01	-X TRANS	H+1.62E-01	0	3
BOTTOM	6	6	7	1	1	1	3.21	LCYL	H+1.62E-01	-X TRANS	H+1.62E-01	0	3
BOTTOM	7	7	8	1	1	1	3.21	LCYL	H+1.62E-01	-X TRANS	H+1.62E-01	0	3
BOTTOM	8	8	9	1	1	1	3.21	LCYL	H+1.62E-01	-X TRANS	H+1.62E-01	0	3
BOTTOM	9	9	10	1	1	1	3.21	LCYL	H+1.62E-01	-X TRANS	H+1.62E-01	0	3
BOTTOM	10	10	11	1	1	1	3.21	LCYL	H+1.62E-01	-X TRANS	H+1.62E-01	0	3
BOTTOM	11	11	12	1	1	1	3.21	LCYL	H+1.62E-01	-X TRANS	H+1.62E-01	0	3
BOTTOM	12	12	13	1	1	1	3.21	LCYL	H+1.62E-01	-X TRANS	H+1.62E-01	0	3

END

ENDCOMP

GROUP VI(B) - SHELL TRIANGLE ELEMENTS

LABEL OR SEQ. NO.	NODE 1		NODE 2		NODE 3		MATL. TYPE	PLATE THICK.	PANEL CODE	H.G. EFF.
	ENPT	SEC	ENPT	SEC	ENPT	SEC				

Module 2 of Substructure 1  
 DATA GROUP IV(A) - DEFINITION OF STRAKES

TYPE	STRAKE	ENDPOINT NUMBERS		MATERIAL TYPE			EFFECT. SPAN	PANEL TYPE	RADIUS OR REF. STRAKE	FRAME WEB ANGLE	LOAD ALLOCATION		EVAL. LEVEL
		EDGE 1	EDGE 2	PLT	STIFF	FRM					OPP. R & SEC/BAY	OR	
BOTTOM	1	1	2	1	1	1	3.21	LCYL	H+1.62E-01	-X TRANS	H+1.62E-01	0	3
BOTTOM	2	2	3	1	1	1	3.21	LCYL	H+1.62E-01	-X TRANS	H+1.62E-01	0	3
BOTTOM	3	3	4	1	1	1	3.21	LCYL	H+1.62E-01	-X TRANS	H+1.62E-01	0	3
BOTTOM	4	4	5	1	1	1	3.21	LCYL	H+1.62E-01	-X TRANS	H+1.62E-01	0	3
BOTTOM	5	5	6	1	1	1	3.21	LCYL	H+1.62E-01	-X TRANS	H+1.62E-01	0	3
BOTTOM	6	6	7	1	1	1	3.21	LCYL	H+1.62E-01	-X TRANS	H+1.62E-01	0	3
BOTTOM	7	7	8	1	1	1	3.21	LCYL	H+1.62E-01	-X TRANS	H+1.62E-01	0	3
BOTTOM	8	8	9	1	1	1	3.21	LCYL	H+1.62E-01	-X TRANS	H+1.62E-01	0	3
BOTTOM	9	9	10	1	1	1	3.21	LCYL	H+1.62E-01	-X TRANS	H+1.62E-01	0	3
BOTTOM	10	10	11	1	1	1	3.21	LCYL	H+1.62E-01	-X TRANS	H+1.62E-01	0	3
BOTTOM	11	11	12	1	1	1	3.21	LCYL	H+1.62E-01	-X TRANS	H+1.62E-01	0	3
BOTTOM	12	12	13	1	1	1	3.21	LCYL	H+1.62E-01	-X TRANS	H+1.62E-01	0	3
END													

ENDCOMP

GROUP VI(B) - SHELL TRIANGLE ELEMENTS

LABEL OR SEQ. NO.	NODE 1		NODE 2		NODE 3		MATL. TYPE	PLATE THICK.	PANEL CODE	H.G. EFF.
	ENPT	SEC	ENPT	SEC	ENPT	SEC				
T1	2	18	-1	0	1	18	1	3.00	W	
T2	3	18	-1	0	2	18	1	3.00	W	
T3	4	18	-1	0	3	18	1	3.00	W	
T4	5	18	-1	0	4	18	1	3.00	W	
T5	6	18	-1	0	5	18	1	3.00	W	
T6	7	18	-1	0	6	18	1	3.00	W	
T7	8	18	-1	0	7	18	1	3.00	W	
T8	9	18	-1	0	8	18	1	3.00	W	
T9	10	18	-1	0	9	18	1	3.00	W	
T10	11	18	-1	0	10	18	1	3.00	W	
T11	12	18	-1	0	11	18	1	3.00	W	



**LOAD CASE: HYDROSTATIC PRESSURE - 4167PSI**

HYDROSTATIC PRESSURE - CYL 2C

=====

INITIAL PANEL ADEQUACY PARAMETER VALUES - MODULE 1 OF SUBSTR. 1

STRAKE	CCBB	CCGB	PCMY	CCLB	PYTF	PYTP	PYCF	PYCP	PSPBT	PSPBL	PFLB
1	1.000	0.002	0.064	0.301	1.000	1.000	1.000	1.000	1.000	1.000	-0.079
2	1.000	0.002	0.064	0.301	1.000	1.000	1.000	1.000	1.000	1.000	-0.079
3	1.000	0.002	0.064	0.301	1.000	1.000	1.000	1.000	1.000	1.000	-0.079
4	1.000	0.002	0.064	0.301	1.000	1.000	1.000	1.000	1.000	1.000	-0.079
5	1.000	0.002	0.064	0.301	1.000	1.000	1.000	1.000	1.000	1.000	-0.079
6	1.000	0.002	0.064	0.301	1.000	1.000	1.000	1.000	1.000	1.000	-0.079
7	1.000	0.002	0.064	0.301	1.000	1.000	1.000	1.000	1.000	1.000	-0.079
8	1.000	0.002	0.064	0.301	1.000	1.000	1.000	1.000	1.000	1.000	-0.079
9	1.000	0.002	0.064	0.301	1.000	1.000	1.000	1.000	1.000	1.000	-0.079
10	1.000	0.002	0.064	0.301	1.000	1.000	1.000	1.000	1.000	1.000	-0.079
11	1.000	0.002	0.064	0.301	1.000	1.000	1.000	1.000	1.000	1.000	-0.079
12	1.000	0.002	0.064	0.301	1.000	1.000	1.000	1.000	1.000	1.000	-0.079

POSITIVE NUMBER: CONSTRAINT SATISFIED. | THESE VALUES ARE NORMALIZED  
 NEGATIVE NUMBER: CONSTRAINT VIOLATED. | BETWEEN +1. AND -1.  
 1.000 : CONSTRAINT NOT RELEVANT OR NULLIFIED BY USER.  
 -2.000 : CONSTRAINT SUPPRESSED.  
 -- : STRAKE NOT EVALUATED.

HYDROSTATIC PRESSURE - CYL 2C

=====

INITIAL PANEL ADEQUACY PARAMETER VALUES - MODULE 2 OF SUBSTR. 1

-----

STRAKE	CCBB	CCGB	PCMY	CCLB	PYTF	PYTP	PYCF	PYCP	PSPBT	PSPBL	PFLB
1	1.000	0.002	0.064	0.301	1.000	1.000	1.000	1.000	1.000	1.000	-0.079
2	1.000	0.002	0.064	0.301	1.000	1.000	1.000	1.000	1.000	1.000	-0.079
3	1.000	0.002	0.064	0.301	1.000	1.000	1.000	1.000	1.000	1.000	-0.079
4	1.000	0.002	0.064	0.301	1.000	1.000	1.000	1.000	1.000	1.000	-0.079
5	1.000	0.002	0.064	0.301	1.000	1.000	1.000	1.000	1.000	1.000	-0.079
6	1.000	0.002	0.064	0.301	1.000	1.000	1.000	1.000	1.000	1.000	-0.079
7	1.000	0.002	0.064	0.301	1.000	1.000	1.000	1.000	1.000	1.000	-0.079
8	1.000	0.002	0.064	0.301	1.000	1.000	1.000	1.000	1.000	1.000	-0.079
9	1.000	0.002	0.064	0.301	1.000	1.000	1.000	1.000	1.000	1.000	-0.079
10	1.000	0.002	0.064	0.301	1.000	1.000	1.000	1.000	1.000	1.000	-0.079
11	1.000	0.002	0.064	0.301	1.000	1.000	1.000	1.000	1.000	1.000	-0.079
12	1.000	0.002	0.064	0.301	1.000	1.000	1.000	1.000	1.000	1.000	-0.079

POSITIVE NUMBER: CONSTRAINT SATISFIED. | THESE VALUES ARE NORMALIZED  
 NEGATIVE NUMBER: CONSTRAINT VIOLATED. | BETWEEN +1. AND -1.  
 1.000 : CONSTRAINT NOT RELEVANT OR NULLIFIED BY USER.  
 -2.000 : CONSTRAINT SUPPRESSED.  
 -- : STRAKE NOT EVALUATED.

## **Appendix C: API (Bull 2U) Solution**

Page Intentionally Left Blank

# Classification Society Solution (API Bulletin 2U)

## NAVSEA Test Cylinder 1.d

### General Definitions

$\text{ksi} := 6.89475710^6 \text{ Pa}$	$\text{rtog} := 64.0 \frac{\text{lb}_f}{\text{ft}^3}$	$\text{kip} := 1000 \text{ lb}_f$	$\text{load} := 1 \frac{\text{kip}}{\text{in}}$
$E := 30000 \text{ ksi}$	Young's Modulus of Elasticity		$\text{kpa} := \frac{\text{kg}}{\text{sec}^2 \cdot \text{m}}$
$F_y := 80 \text{ ksi}$	Yield Strength		
$\nu := .3$	Poisson's ratio for Fe/Steel		
$t := 0.08 \text{ in}$	thickness of shell		
$R_i := 8.007 \text{ m}$	Inner radius of cylinder		
$D_0 := 2 \cdot (R_i + t)$	diameter to outside of shell	$D_0 = 16.176 \text{ in}$	
$L_T := 4.266 \text{ m}$	ring spacing (frame center to frame center)		
$L_b := 22.488 \text{ m}$	length of cylinder between bulkheads or lines of support		

### Ring Stiffener Dimensions

$t_w := 0.138 \text{ in}$	thickness of web of ring stiffener	$t_w = 0.138 \text{ in}$
$h_w := 0.57 \text{ in}$	height of web of ring stiffener	$h_w = 0.57 \text{ in}$
$b := t_w$	faying width of stiffener (from P&S for I beam stiffener)	
$b_f := 0.0 \text{ in}$	breadth of flange of ring stiffener	$b_f = 0 \text{ in}$
$t_f := 0.0 \text{ in}$	flange thickness of ring stiffener	$t_f = 0 \text{ in}$

$$R_0 := \frac{D_0}{2} \quad \text{radius to outside of shell}$$

$$R := R_0 - \frac{t}{2} \quad \text{radius to centerline of shell}$$

$$c_1 := \frac{\frac{t_w \cdot h_w^2}{2} + t_f \cdot b_f \left( h_w + \frac{t_f}{2} \right)}{t_w \cdot h_w + t_f \cdot b_f} \quad \text{dist from shell to centroid} \quad c_1 = 0.285 \text{in}$$

$$c_2 := h_w - c_1 \quad \text{dist from centroid to end of flange} \quad c_2 = 0.285 \text{in}$$

$$Z_r := c_1 + \frac{t}{2} \quad \text{distance from centerline of shell to centroid of ring stiffener (**positive outward**)} \quad Z_r = 0.325 \text{in}$$

$$R_r := R + Z_r \quad \text{radius to centroid of ring stiffener}$$

$$A_r := (t_w \cdot h_w + b_f \cdot t_f) \quad \text{cross-sectional area of ring stiffener} \quad A_r = 0.079 \text{in}^2$$

$$L := L_r - b \quad \text{unsupported shell length} \quad L = 4.128 \text{in}$$

$$I_r := \frac{1}{12} \cdot t_w \cdot h_w^3 + t_w \cdot h_w \left( c_1 - \frac{h_w}{2} \right)^2 + \frac{1}{12} \cdot b_f \cdot t_f^3 + b_f \cdot t_f \left( c_2 + \frac{t_f}{2} \right)^2$$

$$I_r = 2.13 \times 10^{-3} \text{in}^4 \quad \text{moment of inertia of ring stiffener about its centroidal axis}$$

Moment of Inertia Calculations for combined plate and stiffener

$$\theta := \sqrt[4]{3 \cdot (1 - \nu^2)} \cdot \frac{L}{\sqrt{R \cdot t}}$$

$$L_e := 1.56 \sqrt{R \cdot t} \cdot \left( \frac{\cosh(\theta) - \cos(\theta)}{\sinh(\theta) + \sin(\theta)} \right) \quad \text{effective shell length, [P\&S eqn 92]}$$

$$L_e = 1.255 \text{in}$$

$$d := h_w + \frac{t}{2} + \frac{t_f}{2}$$

$$A_p := L_e \cdot t \quad A_w := t_w \cdot h_w \quad A_{fl} := t_f \cdot b_f \quad A_T := A_p + A_w + A_{fl}$$

$$C_1 := \frac{A_w \cdot \left( \frac{A_T}{3} - \frac{A_w}{4} \right) + A_{fl} \cdot A_p}{A_T^2}$$

$$C_2 := \frac{\left( \frac{A_w}{2} + A_p \right)}{A_T}$$

$$y_p := \frac{1}{2} \cdot t + d \cdot (1 - C_2)$$

$$y_f := \frac{1}{2} \cdot t_f + d \cdot C_2$$

$$I_e := A_T \cdot d^2 \cdot C_1 \quad \text{moment of inertia for combined plate/stiffener}$$

[Hughes eqn 8.3.6]

$$I_e = 0.007 \text{in}^4$$

$$R_c := R - \frac{t}{2} + y_p$$

radius to centroidal axis of combined ring stiffener and effective width of shell  
(**outside stiffener -/+, inside +/-**)

$$R_c = 8.181 \text{in}$$

# Failure Modes

## 4.1 - Local Buckling of Unstiffened or Ring Stiffened Cylinders

### 4.1.1 - Axial Compression or Bending

#### a - Elastic Buckling Stresses

$$M_x := \frac{L_r}{\sqrt{R \cdot t}} \quad M_x = 5.284$$

$$D := 2R \quad D = 16.095 \text{ in}$$

$$c := \begin{cases} 2.64 & \text{if } M_x \leq 1.5 \\ \frac{3.13}{(M_x)^{0.42}} & \text{if } 1.5 < M_x < 15 \\ 1.0 & \text{if } M_x \geq 15 \end{cases} \quad c = 1.556$$

$$\alpha_{xL} := \begin{cases} 0.207 & \text{if } \frac{D}{t} \geq 1242 \\ \frac{(169c)}{195 + 0.5 \left(\frac{D}{t}\right)} & \text{if } \frac{D}{t} < 1242 \end{cases} \quad \alpha_{xL} = 0.893$$

$$C_x := 0.605 \quad \text{for } D/t > 300$$

$$F_{xeLr} := \alpha_{xL} \cdot C_x^2 \cdot E \cdot \frac{t}{D}$$

$$F_{xeLr} = 1.125 \times 10^9 \text{ Pa}$$

#### b - Inelastic Buckling Stresses

$$F_{xcLra} := \begin{cases} \frac{233F_y}{166 + 0.5 \left(\frac{D}{t}\right)} & \text{if } \frac{D}{t} < 600 \\ (0.5F_y) & \text{if } \frac{D}{t} \geq 600 \end{cases}$$

$$F_{xcLr} := \min((F_{xeLr} \ F_{xcLra}))$$

$$F_{xcLr} = 4.843 \times 10^8 \text{ Pa}$$



Choose:

$k \equiv 0.5$        $k = 0$  for radial pressure and 0.5 for hydrostatic pressure

#### 4.1.2 - External Pressure

a - Elastic Buckling Stresses

$$A_m := M_x - 1.17 + 1.06k \qquad A_m = 4.648$$

$$C_p := \frac{(2A_m)}{\left(\frac{D}{t}\right)} \qquad C_p := C_p \qquad C_p = 0.047$$

$$p_{eL} := \begin{cases} \left[ \frac{5.08}{A_m^{1.18} + 0.5} \cdot E \cdot \left(\frac{t}{D}\right)^2 \right] & \text{if } M_x > 1.5 \wedge A_m < 2.5 \\ \left[ \frac{3.68}{A_m} \cdot E \cdot \left(\frac{t}{D}\right)^2 \right] & \text{if } 2.5 \leq A_m < 0.104 \left(\frac{D}{t}\right) \\ \left[ 6.688 C_p^{-1.061} \cdot E \cdot \left(\frac{t}{D}\right)^3 \right] & \text{if } 0.208 < C_p < 2.85 \\ \left[ 2.2 \cdot E \cdot \left(\frac{t}{D}\right)^3 \right] & \text{if } C_p \geq 2.85 \end{cases}$$

$$p_{eL} = 601.6 \text{ psi}$$

$\alpha_{\theta L} := .8$       imperfection factor, normally 0.8 for fabricated cyl

$$A := A_r \cdot \left(\frac{R}{R_r}\right)^2 \qquad A = 0.073 \text{ in}^2 \qquad \text{section 11.3}$$

$$L_e := 1.56 \sqrt{R \cdot t} + t_w \qquad L_e = 1.397 \text{ in}$$

$$\psi := \begin{cases} 1.0 & \text{if } M_x \leq 1.26 \\ (1.58 - 0.46 M_x) & \text{if } 1.26 < M_x < 3.42 \\ 0 & \text{if } M_x \geq 3.42 \end{cases}$$

$$\varepsilon := \frac{1 - 0.3k}{1 + \frac{L_e \cdot t}{A}}$$

$$K_{\theta L} := \begin{cases} 1.0 & \text{if } M_x \geq 3.42 \\ 1 - \varepsilon \cdot \psi & \end{cases}$$

$$F_{reLr} := \frac{\alpha_{\theta L} \cdot P_{eL} \cdot R_0}{t} \cdot K_{\theta L}$$

$$F_{reLr} = 48.057 \text{ksi}$$

### c - Inelastic Buckling Stresses

$$\Delta c := \frac{F_{reLr}}{F_y} \quad \Delta c = 0.601$$

$$\eta := \begin{cases} 1 & \text{if } \Delta c \leq 0.55 \\ \left( \frac{0.45}{\Delta c} + 0.18 \right) & \text{if } 0.55 < \Delta c \leq 1.6 \\ \frac{1.31}{1 + 1.15 \Delta c} & \text{if } 1.6 < \Delta c < 6.25 \\ \frac{1}{\Delta c} & \text{if } \Delta c \geq 6.25 \end{cases}$$

$$F_{rcLr} := \eta \cdot F_{reLr} \quad \eta = 0.929$$

$$F_{rcLr} = 4.465 \times 10^4 \text{psi}$$

### d - Failure Pressures

$$P_{cLr} := \eta \cdot \alpha_{\theta L} \cdot P_{eL}$$

$$P_{cLr} = 447.165 \text{psi}$$

## 4.2 - General Instability of Ring Stiffened Cylinders

### 4.2.1 - Axial Compression or Bending

#### a - Elastic Buckling Stresses

$$A_{rb} := \frac{A_r}{L_r \cdot t}$$

$$\alpha_{xL} := \begin{cases} 0.207 & \text{if } \frac{D}{t} \geq 1242 \\ \frac{(169)}{195 + 0.5 \cdot \left(\frac{D}{t}\right)} & \text{if } \frac{D}{t} < 1242 \end{cases}$$

$$\alpha_{xG} := \begin{cases} 0.72 & \text{if } A_{rb} \geq 0.2 \\ \left[ (3.6 - 5.0 \cdot \alpha_{xL}) \cdot A_{rb} + \alpha_{xL} \right] & \text{if } 0.06 < A_{rb} < 0.2 \\ \alpha_{xL} & \text{if } A_{rb} \leq 0.06 \end{cases}$$

$$F_{xcGr} := \alpha_{xG} \cdot 0.605 E \cdot \left(\frac{t}{R}\right) \cdot (1 + A_{rb})^{\frac{1}{2}}$$

$$F_{xcGr} = 1.005 \times 10^9 \text{ Pa}$$

#### c - Inelastic Buckling Stresses

$$\Delta c := \frac{F_{xcGr}}{F_y}$$

$$\eta := \begin{cases} 1 & \text{if } \Delta c \leq 0.55 \\ \left( \frac{0.45}{\Delta c} + 0.18 \right) & \text{if } 0.55 < \Delta c \leq 1.6 \\ \frac{1.31}{1 + 1.15 \Delta c} & \text{if } 1.6 < \Delta c < 6.25 \\ \frac{1}{\Delta c} & \text{if } \Delta c \geq 6.25 \end{cases}$$

$$F_{xcGr} := \eta \cdot F_{xcGr}$$

$$F_{xcGr} = 4.253 \times 10^8 \text{ Pa}$$

#### 4.2.2 - External Pressure

a - Buckling Stresses With or Without End Pressure

$$L_e := \begin{cases} (1.1\sqrt{D}\cdot t + t_w) & \text{if } M_x > 1.56 \\ L_T & \text{if } M_x \leq 1.56 \end{cases}$$

$$I_{er} := I_T + A_r \cdot Z_r^2 \cdot \frac{L_e \cdot t}{A_r + L_e \cdot t} + \frac{L_e \cdot t^3}{12}$$

$$\lambda_G := \frac{\pi R}{L_b}$$

$$p_{eG}(n) := \frac{E \cdot \left(\frac{t}{R}\right) \cdot \lambda_G^4}{\left(n^2 + k \cdot \lambda_G^2 - 1\right) \cdot \left(n^2 + \lambda_G^2\right)^2} + \frac{E \cdot I_{er} \cdot (n^2 - 1)}{I_T \cdot R_c^2 \cdot R_0}$$

$$n := 6$$

Given

$$2 \leq n < 15$$

$$n_1 := \text{Minimiz}(p_{eG}, n)$$

$$n_1 = 3.241$$

$$p_{eG}(n_1) = 1220.78 \text{ psi}$$

$$K_{\theta G} := (1 - 0.3k) \cdot \frac{L_e \cdot t}{A_r + L_e \cdot t}$$

$$\alpha_{\theta G} := .8 \quad \text{imperfection factor, normally 0.8 for fabricated cyl}$$

$$F_{reGr} := \alpha_{\theta G} \cdot \frac{p_{eG}(n_1) \cdot R_0}{t} \cdot K_{\theta G}$$

$$F_{reGr} = 3.37 \times 10^8 \text{ Pa}$$

c - Inelastic Buckling Stresses

$$\Delta c := \frac{F_{reGr}}{F_y}$$

$$\eta := \begin{cases} 1 & \text{if } \Delta c \leq 0.55 \\ \left( \frac{0.45}{\Delta c} + 0.18 \right) & \text{if } 0.55 < \Delta c \leq 1.6 \\ \frac{1.31}{1 + 1.15 \Delta c} & \text{if } 1.6 < \Delta c < 6.25 \\ \frac{1}{\Delta c} & \text{if } \Delta c \geq 6.25 \end{cases}$$

$$F_{rcGr} := \eta \cdot F_{reGr}$$

$$F_{rcGr} = 3.09 \times 10^8 \text{ Pa}$$

d - Failure Pressures

$$p_{cGr} := \eta \cdot \alpha_{\theta G} \cdot p_{eG}(n_1)$$

$$p_{cGr} = 895.44 \text{ psi}$$

## SUMMARY

### 4.1 - Local Buckling of Unstiffened or Ring Stiffened Cylinders

#### 4.1.1 - Axial Compression or Bending

##### a - Elastic Buckling Stresses

$$F_{xeLr} = 1.125 \times 10^9 \text{ Pa} \quad F_{xeLr} = 1.125 \times 10^9 \text{ Pa}$$

##### b - Inelastic Buckling Stresses

$$F_{xcLr} = 4.843 \times 10^8 \text{ Pa} \quad F_{xcLr} = 4.843 \times 10^8 \text{ Pa}$$

#### 4.1.2 - External Pressure

##### a - Elastic Buckling Stresses

$$F_{reLr} = 3.313 \times 10^8 \text{ Pa} \quad F_{reLr} = 3.313 \times 10^8 \text{ Pa}$$

##### c - Inelastic Buckling Stresses

$$F_{rcLr} = 3.079 \times 10^8 \text{ Pa} \quad F_{rcLr} = 3.079 \times 10^8 \text{ Pa}$$

##### d - Failure Pressures

$$p_{cLr} = 3.083 \times 10^6 \text{ Pa} \quad p_{cLr} = 447.165 \text{ psi}$$

### 4.2 - General Instability of Ring Stiffened Cylinders

#### 4.2.1 - Axial Compression or Bending

##### a - Elastic Buckling Stresses

$$F_{xeGr} = 1.005 \times 10^9 \text{ Pa} \quad F_{xeGr} = 1.005 \times 10^9 \text{ Pa}$$

##### c - Inelastic Buckling Stresses

$$F_{xcGr} = 4.253 \times 10^8 \text{ Pa} \quad F_{xcGr} = 4.253 \times 10^8 \text{ Pa}$$

#### 4.2.2 - External Pressure

##### a - Buckling Stresses With or Without End Pressure

$$F_{reGr} = 3.368 \times 10^8 \text{ Pa} \quad F_{reGr} = 3.368 \times 10^8 \text{ Pa}$$

##### c - Inelastic Buckling Stresses

$$F_{rcGr} = 3.088 \times 10^8 \text{ Pa} \quad F_{rcGr} = 3.088 \times 10^8 \text{ Pa}$$

##### d - Failure Pressures

$$p_{cGr} = 6.174 \times 10^6 \text{ Pa} \quad p_{cGr} = 895.44 \text{ psi}$$

# Classification Society Solution (API Bulletin 2U)

## NAVSEA Test Cylinder 1.f

### General Definitions

$\text{ksi} := 6.89475710^6 \text{Pa}$	$\text{rtog} := 64.0 \frac{\text{lbf}}{\text{ft}^3}$	$\text{kip} := 1000 \text{lbf}$	$\text{load} := 1 \frac{\text{kip}}{\text{in}}$
$E := 30000 \text{ksi}$	Young's Modulus of Elasticity		$\text{kpa} := \frac{\text{kg}}{\text{sec}^2 \cdot \text{m}}$
$F_y := 98.5 \text{ksi}$	Yield Strength		
$\nu := .3$	Poisson's ratio for Fe/Steel		
$t := 0.263 \text{in}$	thickness of shell		
$R_i := 17.197 \text{in}$	Inner radius of cylinder		
$D_0 := 2 \cdot (R_i + t)$	diameter to outside of shell	$D_0 = 34.92 \text{in}$	
$L_r := 2.666 \text{m}$	ring spacing (frame center to frame center)		
$L_b := 42.129 \text{m}$	length of cylinder between bulkheads or lines of support		

### Ring Stiffener Dimensions

$t_w := 0.198 \text{in}$	thickness of web of ring stiffener	$t_w = 0.198 \text{in}$
$h_w := 0.762 \text{in}$	height of web of ring stiffener	$h_w = 0.762 \text{in}$
$b := t_w$	faying width of stiffener (from P&S for I beam stiffener)	
$b_f := 0.763 \text{in}$	breadth of flange of ring stiffener	$b_f = 0.763 \text{in}$
$t_f := 0.263 \text{in}$	flange thickness of ring stiffener	$t_f = 0.263 \text{in}$

$$R_0 := \frac{D_0}{2} \quad \text{radius to outside of shell}$$

$$R := R_0 - \frac{t}{2} \quad \text{radius to centerline of shell}$$

$$c_1 := \frac{\frac{t_w \cdot h_w^2}{2} + t_f \cdot b_f \left( h_w + \frac{t_f}{2} \right)}{t_w \cdot h_w + t_f \cdot b_f} \quad \text{dist from shell to centroid} \quad c_1 = 0.674 \text{in}$$

$$c_2 := h_w - c_1 \quad \text{dist from centroid to end of flange} \quad c_2 = 0.088 \text{in}$$

$$Z_r := \left( c_1 + \frac{t}{2} \right) \cdot (-1) \quad \text{distance from centerline of shell to centroid of ring stiffener (**positive outward**)} \quad Z_r = -0.805 \text{in}$$

$$R_r := R + Z_r \quad \text{radius to centroid of ring stiffener} \quad R_r = 16.523 \text{in}$$

$$A_r := (t_w \cdot h_w + b_f \cdot t_f) \quad \text{cross-sectional area of ring stiffener} \quad A_r = 0.352 \text{in}^2$$

$$L := L_r - b \quad \text{unsupported shell length} \quad L = 2.468 \text{in}$$

$$I_r := \frac{1}{12} \cdot t_w \cdot h_w^3 + t_w \cdot h_w \cdot \left( c_1 - \frac{h_w}{2} \right)^2 + \frac{1}{12} \cdot b_f \cdot t_f^3 + b_f \cdot t_f \cdot \left( c_2 + \frac{t_f}{2} \right)^2$$

$$I_r = 0.031 \text{in}^4 \quad \text{moment of inertia of ring stiffener about its centroidal axis}$$

Moment of Inertia Calculations for combined plate and stiffener

$$\theta := \sqrt[4]{3 \cdot (1 - \nu^2)} \cdot \frac{L}{\sqrt{R \cdot t}}$$

$$L_e := 1.56 \sqrt{R \cdot t} \cdot \left( \frac{\cosh(\theta) - \cos(\theta)}{\sinh(\theta) + \sin(\theta)} \right) \quad \text{effective shell length, [P\&S eqn 92]}$$

$$L_e = 2.41 \text{in}$$

$$d := h_w + \frac{t}{2} + \frac{t_f}{2}$$



$$A_p := L_e \cdot t \quad A_w := t_w \cdot h_w \quad A_{fl} := t_f \cdot b_f \quad A_T := A_p + A_w + A_{fl}$$

$$C_1 := \frac{A_w \cdot \left( \frac{A_T}{3} - \frac{A_w}{4} \right) + A_{fl} \cdot A_p}{A_T^2}$$

$$C_2 := \frac{\left( \frac{A_w}{2} + A_p \right)}{A_T}$$

$$y_p := \frac{1}{2} \cdot t + d \cdot (1 - C_2)$$

$$y_f := \frac{1}{2} \cdot t_f + d \cdot C_2$$

$$I_e := A_T \cdot d^2 \cdot C_1 \quad \text{moment of inertia for combined plate/stiffener}$$

[Hughes eqn 8.3.6]

$$I_e = 0.182 \text{in}^4$$

$$R_c := R + \frac{t}{2} - y_p \quad \text{radius to centroidal axis of combined ring stiffener and effective width of shell} \quad R_c = 17.041 \text{in}$$

**(outside stiffener -/+, inside +/-)**

# Failure Modes

## 4.1 - Local Buckling of Unstiffened or Ring Stiffened Cylinders

### 4.1.1 - Axial Compression or Bending

#### a - Elastic Buckling Stresses

$$M_x := \frac{L_r}{\sqrt{R \cdot t}} \quad M_x = 1.249$$

$$D := 2R \quad D = 34.657 \text{ in}$$

$$c := \begin{cases} 2.64 & \text{if } M_x \leq 1.5 \\ \frac{3.13}{(M_x)^{0.42}} & \text{if } 1.5 < M_x < 15 \\ 1.0 & \text{if } M_x \geq 15 \end{cases} \quad c = 2.64$$

$$\alpha_{xL} := \begin{cases} 0.207 & \text{if } \frac{D}{t} \geq 1242 \\ \frac{(169 \cdot c)}{195 + 0.5 \left( \frac{D}{t} \right)} & \text{if } \frac{D}{t} < 1242 \end{cases} \quad \alpha_{xL} = 1.71$$

$$C_x := 0.605 \quad \text{for } D/t > 300$$

$$F_{xeLr} := \alpha_{xL} \cdot C_x \cdot 2 \cdot E \cdot \frac{t}{D}$$

$$F_{xeLr} = 3.248 \times 10^9 \text{ Pa}$$

#### b - Inelastic Buckling Stresses

$$F_{xcLra} := \begin{cases} \frac{233F_y}{166 + 0.5 \left( \frac{D}{t} \right)} & \text{if } \frac{D}{t} < 600 \\ (0.5F_y) & \text{if } \frac{D}{t} \geq 600 \end{cases}$$

$$F_{xcLr} := \min((F_{xeLr} \ F_{xcLra}))$$

$$F_{xcLr} = 6.824 \times 10^8 \text{ Pa}$$

Choose:

$k \equiv 0.5$        $k = 0$  for radial pressure and 0.5 for hydrostatic pressure

#### 4.1.2 - External Pressure

a - Elastic Buckling Stresses

$$\frac{D}{t} = 131.776$$

$$A_m := M_x - 1.17 + 1.06k \quad A_m = 0.613$$

$$C_p := \frac{(2A_m)}{\left(\frac{D}{t}\right)} \quad C_p := C_p \quad C_p = 0.009$$

$$P_{eL} := \begin{cases} \left[ \frac{5.08}{A_m^{1.18} + 0.5} \cdot E \cdot \left(\frac{t}{D}\right)^2 \right] & \text{if } M_x > 1.5 \wedge A_m < 2.5 \\ \left[ \frac{3.68}{A_m} \cdot E \cdot \left(\frac{t}{D}\right)^2 \right] & \text{if } 2.5 \leq A_m < 0.104 \left(\frac{D}{t}\right) \\ \left[ 6.688 C_p^{-1.061} \cdot E \cdot \left(\frac{t}{D}\right)^3 \right] & \text{if } 0.208 < C_p < 2.85 \\ \left[ 2.2 \cdot E \cdot \left(\frac{t}{D}\right)^3 \right] & \text{if } C_p \geq 2.85 \end{cases}$$

Mx is too small, not in range

$P_{eL} = \blacksquare$  psi

\*\*Value not calculated (Mx outside limits)

$\alpha_{\theta L} := 0.8$       imperfection factor, normally 0.8 for fabricated cyl

$$A := A_r \cdot \left(\frac{R}{R_r}\right)^2 \quad A = 0.387 \text{in}^2 \quad \text{section 11.3}$$

$$L_e := 1.56 \sqrt{R \cdot t} + t_w \quad L_e = 3.528 \text{in}$$

$$\psi := \begin{cases} 1.0 & \text{if } M_x \leq 1.26 \\ (1.58 - 0.46M_x) & \text{if } 1.26 < M_x < 3.42 \\ 0 & \text{if } M_x \geq 3.42 \end{cases}$$

$$\varepsilon := \frac{1 - 0.3k}{1 + \frac{L_e \cdot t}{A}}$$

$$K_{\theta L} := \begin{cases} 1.0 & \text{if } M_x \geq 3.42 \\ 1 - \varepsilon \cdot \psi & \end{cases}$$

$$F_{reLr} := \frac{\alpha_{\theta L} \cdot p_{eL} \cdot R_0}{t} \cdot K_{\theta L}$$

$$F_{reLr} = \blacksquare \text{ Pa}$$

### c - Inelastic Buckling Stresses

$$\Delta c := \frac{F_{reLr}}{F_y}$$

$$\eta := \begin{cases} 1 & \text{if } \Delta c \leq 0.55 \\ \left( \frac{0.45}{\Delta c} + 0.18 \right) & \text{if } 0.55 < \Delta c \leq 1.6 \\ \frac{1.31}{1 + 1.15 \Delta c} & \text{if } 1.6 < \Delta c < 6.25 \\ \frac{1}{\Delta c} & \text{if } \Delta c \geq 6.25 \end{cases}$$

$$F_{rcLr} := \eta \cdot F_{reLr}$$

$$F_{rcLr} = \blacksquare \text{ Pa}$$

### d - Failure Pressures

$$p_{cLr} := \eta \cdot \alpha_{\theta L} \cdot p_{eL}$$

$$p_{cLr} = \blacksquare \text{ psi}$$

\*\*Value not calculated  
(Mx outside limits)

## 4.2 - General Instability of Ring Stiffened Cylinders

### 4.2.1 - Axial Compression or Bending

#### a - Elastic Buckling Stresses

$$A_{rb} := \frac{A_r}{L_r \cdot t}$$

$$\alpha_{xL} := \begin{cases} 0.207 & \text{if } \frac{D}{t} \geq 1242 \\ \frac{(169)}{195 + 0.5 \cdot \left(\frac{D}{t}\right)} & \text{if } \frac{D}{t} < 1242 \end{cases}$$

$$\alpha_{xG} := \begin{cases} 0.72 & \text{if } A_{rb} \geq 0.2 \\ \left[ \left( (3.6 - 5.0 \cdot \alpha_{xL}) \cdot A_{rb} + \alpha_{xL} \right) \right] & \text{if } 0.06 < A_{rb} < 0.2 \\ \alpha_{xL} & \text{if } A_{rb} \leq 0.06 \end{cases}$$

$$F_{xeGr} := \alpha_{xG} \cdot 0.605 E \cdot \left(\frac{t}{R}\right) \cdot (1 + A_{rb})^{\frac{1}{2}}$$

$$F_{xeGr} = 1.676 \times 10^9 \text{ Pa}$$

#### c - Inelastic Buckling Stresses

$$\Delta c := \frac{F_{xeGr}}{F_y}$$

$$\eta := \begin{cases} 1 & \text{if } \Delta c \leq 0.55 \\ \left( \frac{0.45}{\Delta c} + 0.18 \right) & \text{if } 0.55 < \Delta c \leq 1.6 \\ \frac{1.31}{1 + 1.15 \Delta c} & \text{if } 1.6 < \Delta c < 6.25 \\ \frac{1}{\Delta c} & \text{if } \Delta c \geq 6.25 \end{cases}$$

$$F_{xcGr} := \eta \cdot F_{xeGr}$$

$$F_{xcGr} = 5.72 \times 10^8 \text{ Pa}$$

## 4.2.2 - External Pressure

a - Buckling Stresses With or Without End Pressure

$$L_e := \begin{cases} (1.1\sqrt{D}\cdot t + t_w) & \text{if } M_x > 1.56 \\ L_T & \text{if } M_x \leq 1.56 \end{cases}$$

$$I_{er} := I_T + A_r \cdot Z_r^2 \cdot \frac{L_e \cdot t}{A_r + L_e \cdot t} + \frac{L_e \cdot t^3}{12}$$

$$\lambda_G := \frac{\pi R}{L_b}$$

$$p_{eG(n)} := \frac{E \cdot \left(\frac{t}{R}\right) \cdot \lambda_G^4}{\left(n^2 + k \cdot \lambda_G^2 - 1\right) \cdot \left(n^2 + \lambda_G^2\right)^2} + \frac{E \cdot I_{er} \cdot (n^2 - 1)}{I_T \cdot R_c^2 \cdot R_0}$$

$$n := 6$$

Given

$$2 \leq n < 15$$

$$n_1 := \text{Minimiz}(p_{eG}, n)$$

$$n_1 = 2.963$$

$$p_{eG}(n_1) = 4576.00 \text{ psi}$$

$$K_{\theta G} := (1 - 0.3k) \cdot \frac{L_e \cdot t}{A_r + L_e \cdot t}$$

$$\alpha_{\theta G} := 0.8$$

$$F_{reGr} := \alpha_{\theta G} \cdot \frac{p_{eG}(n_1) \cdot R_0}{t} \cdot K_{\theta G}$$

$$F_{reGr} = 9.49 \times 10^8 \text{ Pa}$$

c - Inelastic Buckling Stresses

$$\Delta c := \frac{F_{reGr}}{F_y}$$

$$\eta := \begin{cases} 1 & \text{if } \Delta c \leq 0.55 \\ \left( \frac{0.45}{\Delta c} + 0.18 \right) & \text{if } 0.55 < \Delta c \leq 1.6 \\ \frac{1.31}{1 + 1.15 \Delta c} & \text{if } 1.6 < \Delta c < 6.25 \\ \frac{1}{\Delta c} & \text{if } \Delta c \geq 6.25 \end{cases}$$

$$F_{rcGr} := \eta \cdot F_{reGr}$$

$$F_{rcGr} = 4.76 \times 10^8 \text{ Pa}$$

d - Failure Pressures

$$p_{cGr} := \eta \cdot \alpha_{\theta G} \cdot p_{eG}(n_1)$$

$$p_{cGr} = 1838.26 \text{ psi}$$

## SUMMARY

### 4.1 - Local Buckling of Unstiffened or Ring Stiffened Cylinders

#### 4.1.1 - Axial Compression or Bending

##### a - Elastic Buckling Stresses

$$F_{xeLr} = 3.248 \times 10^9 \text{ Pa}$$

$$F_{xeLr} = 3.248 \times 10^9 \text{ Pa}$$

##### b - Inelastic Buckling Stresses

$$F_{xcLr} = 6.824 \times 10^8 \text{ Pa}$$

$$F_{xcLr} = 6.824 \times 10^8 \text{ Pa}$$

#### 4.1.2 - External Pressure

##### a - Elastic Buckling Stresses

$$F_{reLr} = \blacksquare \text{ Pa}$$

$$F_{reLr} = \blacksquare \text{ Pa}$$

##### c - Inelastic Buckling Stresses

$$F_{rcLr} = \blacksquare \text{ Pa}$$

$$F_{rcLr} = \blacksquare \text{ Pa}$$

##### d - Failure Pressures

$$p_{cLr} = \blacksquare \text{ Pa}$$

$$p_{cLr} = \blacksquare \text{ psi}$$

\*\*Value not calculated  
(Mx outside limits)

### 4.2 - General Instability of Ring Stiffened Cylinders

#### 4.2.1 - Axial Compression or Bending

##### a - Elastic Buckling Stresses

$$F_{xeGr} = 1.676 \times 10^9 \text{ Pa}$$

$$F_{xeGr} = 1.676 \times 10^9 \text{ Pa}$$

##### c - Inelastic Buckling Stresses

$$F_{xcGr} = 5.72 \times 10^8 \text{ Pa}$$

$$F_{xcGr} = 5.72 \times 10^8 \text{ Pa}$$

#### 4.2.2 - External Pressure

##### a - Buckling Stresses With or Without End Pressure

$$F_{reGr} = 9.487 \times 10^8 \text{ Pa}$$

$$F_{reGr} = 9.487 \times 10^8 \text{ Pa}$$

##### c - Inelastic Buckling Stresses

$$F_{rcGr} = 4.764 \times 10^8 \text{ Pa}$$

$$F_{rcGr} = 4.764 \times 10^8 \text{ Pa}$$

##### d - Failure Pressures

$$p_{cGr} = 1.267 \times 10^7 \text{ Pa}$$

$$p_{cGr} = 1838.26 \text{ psi}$$



# Classification Society Solution (API Bulletin 2U)

## NAVSEA Test Cylinder 2.a

### General Definitions

$\text{ksi} := 6.89475710^6 \text{Pa}$	$\text{rtog} := 64.0 \frac{\text{lbft}}{\text{ft}^3}$	$\text{kip} := 1000 \text{bf}$	$\text{bload} := 1 \frac{\text{kip}}{\text{in}}$
$E := 30000 \text{ksi}$	Young's Modulus of Elasticity		$\text{kpa} := \frac{\text{kg}}{\text{sec}^2 \cdot \text{m}}$
$F_y := 65.5 \text{ksi}$	Yield Strength		
$\nu := .3$	Poisson's ratio for Fe/Steel		
$t := 0.0858 \text{in}$	thickness of shell		
$R_i := 8.375 \text{in}$	Inner radius of cylinder		
$D_0 := 2 \cdot (R_i + t)$	diameter to outside of shell	$D_0 = 16.922 \text{in}$	
$L_r := 1.366 \text{in}$	ring spacing (frame center to frame center)		
$L_b := 8.636 \text{in}$	length of cylinder between bulkheads or lines of support		

### Ring Stiffener Dimensions

$t_w := 0.044 \text{in}$	thickness of web of ring stiffener	$t_w = 0.044 \text{in}$
$h_w := 0.4539 \text{in}$	height of web of ring stiffener	$h_w = 0.454 \text{in}$
$b := t_w$	faying width of stiffener (from P&S for I beam stiffener)	
$b_f := 0.399 \text{in}$	breadth of flange of ring stiffener	$b_f = 0.399 \text{in}$
$t_f := 0.078 \text{in}$	flange thickness of ring stiffener	$t_f = 0.078 \text{in}$

$$R_0 := \frac{D_0}{2} \quad \text{radius to outside of shell}$$

$$R := R_0 - \frac{t}{2} \quad \text{radius to centerline of shell}$$

$$c_1 := \frac{\frac{t_w \cdot h_w^2}{2} + t_f \cdot b_f \left( h_w + \frac{t_f}{2} \right)}{t_w \cdot h_w + t_f \cdot b_f} \quad \text{dist from shell to centroid} \quad c_1 = 0.389\text{in}$$

$$c_2 := h_w - c_1 \quad \text{dist from centroid to end of flange} \quad c_2 = 0.065\text{in}$$

$$Z_r := c_1 + \frac{t}{2} \quad \text{distance from centerline of shell to centroid of ring stiffener (positive outward)} \quad Z_r = 0.432\text{in}$$

$$R_r := R + Z_r \quad \text{radius to centroid of ring stiffener}$$

$$A_r := (t_w \cdot h_w + b_f \cdot t_f) \quad \text{cross-sectional area of ring stiffener} \quad A_r = 0.051\text{in}^2$$

$$L := L_r - b \quad \text{unsupported shell length} \quad L = 1.322\text{in}$$

$$I_r := \frac{1}{12} \cdot t_w \cdot h_w^3 + t_w \cdot h_w \left( c_1 - \frac{h_w}{2} \right)^2 + \frac{1}{12} \cdot b_f \cdot t_f^3 + b_f \cdot t_f \left( c_2 + \frac{t_f}{2} \right)^2$$

$$I_r = 1.219 \times 10^{-3} \text{in}^4 \quad \text{moment of inertia of ring stiffener about its centroidal axis}$$

Moment of Inertia Calculations for combined plate and stiffener

$$\theta := \sqrt[4]{3 \cdot (1 - \nu^2)} \cdot \frac{L}{\sqrt{R \cdot t}}$$

$$L_e := 1.56 \sqrt{R \cdot t} \cdot \left( \frac{\cosh(\theta) - \cos(\theta)}{\sinh(\theta) + \sin(\theta)} \right) \quad \text{effective shell length, [P\&S eqn 92]}$$

$$L_e = 1.221\text{in}$$

$$d := h_w + \frac{t}{2} + \frac{t_f}{2}$$

$$A_p := L_e \cdot t \quad A_w := t_w \cdot h_w \quad A_{fl} := t_f \cdot b_f \quad A_T := A_p + A_w + A_{fl}$$

$$C_1 := \frac{A_w \cdot \left( \frac{A_T}{3} - \frac{A_w}{4} \right) + A_{fl} \cdot A_p}{A_T^2} \quad C_2 := \frac{\left( \frac{A_w}{2} + A_p \right)}{A_T}$$

$$y_p := \frac{1}{2} \cdot t + d \cdot (1 - C_2)$$

$$y_f := \frac{1}{2} \cdot t_f + d \cdot C_2$$

$$I_e := A_T \cdot d^2 \cdot C_1 \quad \text{moment of inertia for combined plate/stiffener}$$

[Hughes eqn 8.3.6]

$$I_e = 0.008 \text{in}^4$$

$$R_c := R - \frac{t}{2} + y_p \quad \text{radius to centroidal axis of combined ring stiffener and effective width of shell} \quad R_c = 8.559 \text{in}$$

**(outside stiffener -/+, inside +/-)**

# Failure Modes

## 4.1 - Local Buckling of Unstiffened or Ring Stiffened Cylinders

### 4.1.1 - Axial Compression or Bending

#### a - Elastic Buckling Stresses

$$M_x := \frac{L_r}{\sqrt{R \cdot t}} \quad M_x = 1.607$$

$$D := 2R \quad D = 16.836 \text{ in}$$

$$c := \begin{cases} 2.64 & \text{if } M_x \leq 1.5 \\ \frac{3.13}{(M_x)^{0.42}} & \text{if } 1.5 < M_x < 15 \\ 1.0 & \text{if } M_x \geq 15 \end{cases} \quad c = 2.564$$

$$\alpha_{xL} := \begin{cases} 0.207 & \text{if } \frac{D}{t} \geq 1242 \\ \frac{(169c)}{195 + 0.5 \cdot \left(\frac{D}{t}\right)} & \text{if } \frac{D}{t} < 1242 \end{cases} \quad \alpha_{xL} = 1.479$$

$$C_x := 0.605 \quad \text{for } D/t > 300$$

$$F_{xeLr} := \alpha_{xL} \cdot C_x^2 \cdot E \cdot \frac{t}{D}$$

$$F_{xeLr} = 1.886 \times 10^9 \text{ Pa}$$

#### b - Inelastic Buckling Stresses

$$F_{xcLra} := \begin{cases} \frac{233F_y}{166 + 0.5 \cdot \left(\frac{D}{t}\right)} & \text{if } \frac{D}{t} < 600 \\ (0.5F_y) & \text{if } \frac{D}{t} \geq 600 \end{cases}$$

$$F_{xcLr} := \min((F_{xeLr} \ F_{xcLra}))$$

$$F_{xcLr} = 3.984 \times 10^8 \text{ Pa}$$

Choose:

$k \equiv 0.5$        $k = 0$  for radial pressure and 0.5 for hydrostatic pressure

#### 4.1.2 - External Pressure

a - Elastic Buckling Stresses

$$A_m := M_x - 1.17 + 1.06k \qquad A_m = 0.971$$

$$C_p := \frac{(2A_m)}{\left(\frac{D}{t}\right)} \qquad C_p := C_p \qquad C_p = 9.9 \times 10^{-3}$$

$$p_{eL} := \begin{cases} \left[ \frac{5.08}{A_m^{1.18} + 0.5} \cdot E \cdot \left(\frac{t}{D}\right)^2 \right] & \text{if } M_x > 1.5 \wedge A_m < 2.5 \\ \left[ \frac{3.68}{A_m} \cdot E \cdot \left(\frac{t}{D}\right)^2 \right] & \text{if } 2.5 \leq A_m < 0.104 \left(\frac{D}{t}\right) \\ \left[ 6.688 C_p^{-1.061} \cdot E \cdot \left(\frac{t}{D}\right)^3 \right] & \text{if } 0.208 < C_p < 2.85 \\ \left[ 2.2 \cdot E \cdot \left(\frac{t}{D}\right)^3 \right] & \text{if } C_p \geq 2.85 \end{cases}$$

$$p_{eL} = 2699.49 \text{psi}$$

$\alpha_{\theta L} := 0.8$       imperfection factor, normally 0.8 for fabricated cyl

$$A := A_r \cdot \left(\frac{R}{R_r}\right)^2 \qquad A = 0.046 \text{in}^2 \qquad \text{section 11.3}$$

$$L_e := 1.56\sqrt{R \cdot t} + t_w \qquad L_e = 1.37 \text{in}$$

$$\psi := \begin{cases} 1.0 & \text{if } M_x \leq 1.26 \\ (1.58 - 0.46M_x) & \text{if } 1.26 < M_x < 3.42 \\ 0 & \text{if } M_x \geq 3.42 \end{cases}$$

$$\varepsilon := \frac{1 - 0.3k}{1 + \frac{L_e \cdot t}{A}}$$

$$K_{\theta L} := \begin{cases} 1.0 & \text{if } M_x \geq 3.42 \\ 1 - \varepsilon \cdot \psi & \end{cases}$$

$$F_{reLr} := \frac{\alpha_{\theta L} \cdot p_{eL} \cdot R_0}{t} \cdot K_{\theta L}$$

$$F_{reLr} = 1.172 \times 10^9 \text{ Pa}$$

### c - Inelastic Buckling Stresses

$$\Delta c := \frac{F_{reLr}}{F_y}$$

$$\eta := \begin{cases} 1 & \text{if } \Delta c \leq 0.55 \\ \left( \frac{0.45}{\Delta c} + 0.18 \right) & \text{if } 0.55 < \Delta c \leq 1.6 \\ \frac{1.31}{1 + 1.15 \Delta c} & \text{if } 1.6 < \Delta c < 6.25 \\ \frac{1}{\Delta c} & \text{if } \Delta c \geq 6.25 \end{cases}$$

$$F_{rcLr} := \eta \cdot F_{reLr} \quad \eta = 0.329$$

$$F_{rcLr} = 3.853 \times 10^8 \text{ Pa}$$

### d - Failure Pressures

$$p_{cLr} := \eta \cdot \alpha_{\theta L} \cdot p_{eL}$$

$$p_{cLr} = 709.97 \text{ psi}$$

## 4.2 - General Instability of Ring Stiffened Cylinders

### 4.2.1 - Axial Compression or Bending

#### a - Elastic Buckling Stresses

$$A_{rb} := \frac{A_r}{L_r \cdot t}$$

$$\alpha_{xL} := \begin{cases} 0.207 & \text{if } \frac{D}{t} \geq 1242 \\ \frac{(169)}{195 + 0.5 \cdot \left(\frac{D}{t}\right)} & \text{if } \frac{D}{t} < 1242 \end{cases}$$

$$\alpha_{xG} := \begin{cases} 0.72 & \text{if } A_{rb} \geq 0.2 \\ \left[ (3.6 - 5.0 \cdot \alpha_{xL}) \cdot A_{rb} + \alpha_{xL} \right] & \text{if } 0.06 < A_{rb} < 0.2 \\ \alpha_{xL} & \text{if } A_{rb} \leq 0.06 \end{cases}$$

$$F_{xeGr} := \alpha_{xG} \cdot 0.605 E \cdot \left(\frac{t}{R}\right) \cdot (1 + A_{rb})^{\frac{1}{2}}$$

$$F_{xeGr} = 1.1 \times 10^9 \text{ Pa}$$

#### c - Inelastic Buckling Stresses

$$\Delta c := \frac{F_{xeGr}}{F_y}$$

$$\eta := \begin{cases} 1 & \text{if } \Delta c \leq 0.55 \\ \left( \frac{0.45}{\Delta c} + 0.18 \right) & \text{if } 0.55 < \Delta c \leq 1.6 \\ \frac{1.31}{1 + 1.15 \Delta c} & \text{if } 1.6 < \Delta c < 6.25 \\ \frac{1}{\Delta c} & \text{if } \Delta c \geq 6.25 \end{cases}$$

$$F_{xcGr} := \eta \cdot F_{xeGr}$$

$$F_{xcGr} = 3.791 \times 10^8 \text{ Pa}$$

## 4.2.2 - External Pressure

a - Buckling Stresses With or Without End Pressure

$$L_e := \begin{cases} (1.1\sqrt{D \cdot t} + t_w) & \text{if } M_x > 1.56 \\ L_T & \text{if } M_x \leq 1.56 \end{cases}$$

$$I_{er} := I_T + A_T \cdot Z_T^2 \cdot \frac{L_e \cdot t}{A_T + L_e \cdot t} + \frac{L_e \cdot t^3}{12}$$

$$\lambda_G := \frac{\pi R}{L_b}$$

$$p_{eG}(n) := \frac{E \cdot \left(\frac{t}{R}\right) \cdot \lambda_G^4}{\left(n^2 + k \cdot \lambda_G^2 - 1\right) \cdot \left(n^2 + \lambda_G^2\right)^2} + \frac{E \cdot I_{er} \cdot (n^2 - 1)}{L_T \cdot R_c^2 \cdot R_0}$$

$$n := 6$$

Given

$$2 \leq n < 15$$

$$n_1 := \text{Minimize}(p_{eG}, n)$$

$$n_1 = 3.984$$

$$p_{eG}(n_1) = 6333.09 \text{ psi}$$

$$K_{\theta G} := (1 - 0.3k) \cdot \frac{L_e \cdot t}{A_T + L_e \cdot t}$$

$$\alpha_{\theta G} := 0.8$$

$$F_{reGr} := \alpha_{\theta G} \cdot \frac{p_{eG}(n_1) \cdot R_0}{t} \cdot K_{\theta G}$$

$$F_{reGr} = 2.04 \times 10^9 \text{ Pa}$$



c - Inelastic Buckling Stresses

$$\Delta c := \frac{F_{reGr}}{F_y}$$

$$\eta := \begin{cases} 1 & \text{if } \Delta c \leq 0.55 \\ \left( \frac{0.45}{\Delta c} + 0.18 \right) & \text{if } 0.55 < \Delta c \leq 1.6 \\ \frac{1.31}{1 + 1.15 \Delta c} & \text{if } 1.6 < \Delta c < 6.25 \\ \frac{1}{\Delta c} & \text{if } \Delta c \geq 6.25 \end{cases}$$

$$F_{rcGr} := \eta \cdot F_{reGr}$$

$$F_{rcGr} = 4.31 \times 10^8 \text{ Pa}$$

d - Failure Pressures

$$p_{cGr} := \eta \cdot \alpha_{\theta G} p_{eG}(n_1)$$

$$p_{cGr} = 1071.8 \text{ psi}$$

## SUMMARY

### 4.1 - Local Buckling of Unstiffened or Ring Stiffened Cylinders

#### 4.1.1 - Axial Compression or Bending

##### a - Elastic Buckling Stresses

$$F_{xeLr} = 1.886 \times 10^9 \text{ Pa} \quad F_{xeLr} = 1.886 \times 10^9 \text{ Pa}$$

##### b - Inelastic Buckling Stresses

$$F_{xcLr} = 3.984 \times 10^8 \text{ Pa} \quad F_{xcLr} = 3.984 \times 10^8 \text{ Pa}$$

#### 4.1.2 - External Pressure

##### a - Elastic Buckling Stresses

$$F_{reLr} = 1.172 \times 10^9 \text{ Pa} \quad F_{reLr} = 1.172 \times 10^9 \text{ Pa}$$

##### c - Inelastic Buckling Stresses

$$F_{rcLr} = 3.853 \times 10^8 \text{ Pa} \quad F_{rcLr} = 3.853 \times 10^8 \text{ Pa}$$

##### d - Failure Pressures

$$p_{cLr} = 4.895 \times 10^6 \text{ Pa} \quad p_{cLr} = 709.97 \text{ psi}$$

### 4.2 - General Instability of Ring Stiffened Cylinders

#### 4.2.1 - Axial Compression or Bending

##### a - Elastic Buckling Stresses

$$F_{xeGr} = 1.1 \times 10^9 \text{ Pa} \quad F_{xeGr} = 1.1 \times 10^9 \text{ Pa}$$

##### c - Inelastic Buckling Stresses

$$F_{xcGr} = 3.791 \times 10^8 \text{ Pa} \quad F_{xcGr} = 3.791 \times 10^8 \text{ Pa}$$

#### 4.2.2 - External Pressure

##### a - Buckling Stresses With or Without End Pressure

$$F_{reGr} = 2.039 \times 10^9 \text{ Pa} \quad F_{reGr} = 2.039 \times 10^9 \text{ Pa}$$

##### c - Inelastic Buckling Stresses

$$F_{rcGr} = 4.314 \times 10^8 \text{ Pa} \quad F_{rcGr} = 4.314 \times 10^8 \text{ Pa}$$

##### d - Failure Pressures

$$p_{cGr} = 7.39 \times 10^6 \text{ Pa} \quad p_{cGr} = 1071.8 \text{ psi}$$

# Classification Society Solution (API Bulletin 2U)

## NAVSEA Test Cylinder 2.c

### General Defintions

$\text{ksi} := 6.89475710^6 \text{Pa}$	$\text{rtog} := 64.0 \frac{\text{lbft}}{\text{ft}^3}$	$\text{kip} := 1000 \text{bf}$	$\text{bload} := 1 \frac{\text{kip}}{\text{in}}$
$E := 30000 \text{ksi}$	Young's Modulus of Elasticity		$\text{kpa} := \frac{\text{kg}}{\text{sec}^2 \cdot \text{m}}$
$F_y := 157 \text{ksi}$	Yield Strength		
$\nu := .3$	Poison's ratio for Fe/Steel		
$t := 0.337 \text{in}$	thickness of shell		
$R_i := 18.714 \text{in}$	Inner radius of cylinder		
$D_0 := 2 \cdot (R_i + t)$	diameter to outside of shell	$D_0 = 38.102 \text{in}$	
$L_r := 3.256 \text{in}$	ring spacing (frame center to frame center)		
$L_b := 115.532 \text{in}$	length of cylinder between bulkheads or lines of support		

### Ring Stiffener Dimensions

$t_w := 0.127 \text{in}$	thickness of web of ring stiffener	$t_w = 0.127 \text{in}$
$h_w := 2.01 \text{in}$	height of web of ring stiffener	$h_w = 2.01 \text{in}$
$b := t_w$	faying width of stiffener (from P&S for I beam stiffener)	
$b_f := 1.552 \text{in}$	breadth of flange of ring stiffener	$b_f = 1.552 \text{in}$
$t_f := 0.305 \text{in}$	flange thickness of ring stiffener	$t_f = 0.305 \text{in}$

$$R_0 := \frac{D_0}{2} \quad \text{radius to outside of shell}$$

$$R := R_0 - \frac{t}{2} \quad \text{radius to centerline of shell}$$

$$c_1 := \frac{\frac{t_w \cdot h_w^2}{2} + t_f \cdot b_f \left( h_w + \frac{t_f}{2} \right)}{t_w \cdot h_w + t_f \cdot b_f} \quad \text{dist from shell to centroid} \quad c_1 = 1.757 \text{in}$$

$$c_2 := h_w - c_1 \quad \text{dist from centroid to end of flange} \quad c_2 = 0.253 \text{in}$$

$$Z_r := \left( c_1 + \frac{t}{2} \right) \cdot (-1) \quad \text{distance from centerline of shell to centroid of ring stiffener (**positive outward**)} \quad Z_r = -1.925 \text{in}$$

$$R_r := R + Z_r \quad \text{radius to centroid of ring stiffener} \quad R_r = 16.957 \text{in}$$

$$A_r := (t_w \cdot h_w + b_f \cdot t_f) \quad \text{cross-sectional area of ring stiffener} \quad A_r = 0.729 \text{in}^2$$

$$L := L_r - b \quad \text{unsupported shell length} \quad L = 3.129 \text{in}$$

$$I_r := \frac{1}{12} \cdot t_w \cdot h_w^3 + t_w \cdot h_w \cdot \left( c_1 - \frac{h_w}{2} \right)^2 + \frac{1}{12} \cdot b_f \cdot t_f^3 + b_f \cdot t_f \cdot \left( c_2 + \frac{t_f}{2} \right)^2$$

$$I_r = 0.312 \text{in}^4 \quad \text{moment of inertia of ring stiffener about its centroidal axis}$$

Moment of Inertia Calculations for combined plate and stiffener

$$\theta := \sqrt[4]{3 \cdot (1 - \nu^2)} \cdot \frac{L}{\sqrt{R \cdot t}}$$

$$L_e := 1.56 \sqrt{R \cdot t} \cdot \left( \frac{\cosh(\theta) - \cos(\theta)}{\sinh(\theta) + \sin(\theta)} \right) \quad \text{effective shell length, [P\&S eqn 92]}$$

$$L_e = 3.03 \text{in}$$

$$d := h_w + \frac{t}{2} + \frac{t_f}{2}$$

$$A_p := L_e \cdot t \quad A_w := t_w \cdot h_w \quad A_{fl} := t_f \cdot b_f \quad A_T := A_p + A_w + A_{fl}$$

$$C_1 := \frac{A_w \cdot \left( \frac{A_T}{3} - \frac{A_w}{4} \right) + A_{fl} \cdot A_p}{A_T^2} \quad C_2 := \frac{\left( \frac{A_w}{2} + A_p \right)}{A_T}$$

$$y_p := \frac{1}{2} \cdot t + d \cdot (1 - C_2)$$

$$y_f := \frac{1}{2} \cdot t_f + d \cdot C_2$$

$$I_e := A_T \cdot d^2 \cdot C_1 \quad \text{moment of inertia for combined plate/stiffener}$$

[Hughes eqn 8.3.6]

$$I_e = 1.913 \text{in}^4$$

$$R_c := R + \frac{t}{2} - y_p \quad \text{radius to centroidal axis of combined ring stiffener and effective width of shell} \quad R_c = 18.082 \text{in}$$

**(outside stiffener -/+, inside +/-)**

# Failure Modes

## 4.1 - Local Buckling of Unstiffened or Ring Stiffened Cylinders

### 4.1.1 - Axial Compression or Bending

#### a - Elastic Buckling Stresses

$$M_x := \frac{L_T}{\sqrt{R \cdot t}}$$

$$M_x = 1.291$$

$$D := 2R$$

$$D = 37.765 \text{ in}$$

$$c := \begin{cases} 2.64 & \text{if } M_x \leq 1.5 \\ \frac{3.13}{(M_x)^{0.42}} & \text{if } 1.5 < M_x < 15 \\ 1.0 & \text{if } M_x \geq 15 \end{cases}$$

$$c = 2.64$$

$$\alpha_{xL} := \begin{cases} 0.207 & \text{if } \frac{D}{t} \geq 1242 \\ \frac{(169 \cdot c)}{195 + 0.5 \cdot \left(\frac{D}{t}\right)} & \text{if } \frac{D}{t} < 1242 \end{cases}$$

$$\alpha_{xL} = 1.777$$

$$C_x := 0.605 \quad \text{for } D/t > 300$$

$$F_{xeLr} := \alpha_{xL} \cdot C_x \cdot 2 \cdot E \cdot \frac{t}{D}$$

$$F_{xeLr} = 3.969 \times 10^9 \text{ Pa}$$

#### b - Inelastic Buckling Stresses

$$F_{xcLra} := \begin{cases} \frac{233F_y}{166 + 0.5 \cdot \left(\frac{D}{t}\right)} & \text{if } \frac{D}{t} < 600 \\ (0.5F_y) & \text{if } \frac{D}{t} \geq 600 \end{cases}$$

$$F_{xcLr} := \min((F_{xeLr} \ F_{xcLra}))$$

$$F_{xcLr} = 1.136 \times 10^9 \text{ Pa}$$

Choose:

$k \equiv 0.5$        $k = 0$  for radial pressure and 0.5 for hydrostatic pressure

#### 4.1.2 - External Pressure

a - Elastic Buckling Stresses

$$\frac{D}{t} = 112.062$$

$$A_m := M_x - 1.17 + 1.06k \quad A_m = 0.655 \quad M_x = 1.291$$

$$C_p := \frac{(2A_m)}{\left(\frac{D}{t}\right)} \quad C_p := C_p \quad C_p = 0.012$$

$$P_{eL} := \begin{cases} \left[ \frac{5.08}{A_m^{1.18 + 0.5}} \cdot E \cdot \left(\frac{t}{D}\right)^2 \right] & \text{if } M_x > 1.5 \wedge A_m < 2.5 \\ \left[ \frac{3.68}{A_m} \cdot E \cdot \left(\frac{t}{D}\right)^2 \right] & \text{if } 2.5 \leq A_m < 0.104 \left(\frac{D}{t}\right) \\ \left[ 6.688 C_p^{-1.061} \cdot E \cdot \left(\frac{t}{D}\right)^3 \right] & \text{if } 0.208 < C_p < 2.85 \\ \left[ 2.2 \cdot E \cdot \left(\frac{t}{D}\right)^3 \right] & \text{if } C_p \geq 2.85 \end{cases}$$

Mx is too small, not in range

$$P_{eL} = \blacksquare \text{ psi}$$

\*\*Value not calculated  
(Mx outside limits)

$\alpha_{\theta L} := 0.8$       imperfection factor, normally 0.8 for fabricated cyl

$$A := A_r \cdot \left(\frac{R}{R_r}\right)^2 \quad A = 0.903 \text{in}^2 \quad \text{section 11.3}$$

$$L_e := 1.56\sqrt{R \cdot t} + t_w \quad L_e = 4.062 \text{in}$$

$$\psi := \begin{cases} 1.0 & \text{if } M_x \leq 1.26 \\ (1.58 - 0.46M_x) & \text{if } 1.26 < M_x < 3.42 \\ 0 & \text{if } M_x \geq 3.42 \end{cases}$$

$$\varepsilon := \frac{1 - 0.3k}{1 + \frac{L_e \cdot t}{A}}$$

$$K_{\theta L} := \begin{cases} 1.0 & \text{if } M_x \geq 3.42 \\ 1 - \varepsilon \cdot \psi & \end{cases}$$

$$F_{reLr} := \frac{\alpha_{\theta L} \cdot p_{eL} \cdot R_0}{t} \cdot K_{\theta L}$$

$$F_{reLr} = \blacksquare \text{ Pa}$$

### c - Inelastic Buckling Stresses

$$\Delta c := \frac{F_{reLr}}{F_y}$$

$$\eta := \begin{cases} 1 & \text{if } \Delta c \leq 0.55 \\ \left( \frac{0.45}{\Delta c} + 0.18 \right) & \text{if } 0.55 < \Delta c \leq 1.6 \\ \frac{1.31}{1 + 1.15 \Delta c} & \text{if } 1.6 < \Delta c < 6.25 \\ \frac{1}{\Delta c} & \text{if } \Delta c \geq 6.25 \end{cases}$$

$$F_{rcLr} := \eta \cdot F_{reLr}$$

$$F_{rcLr} = \blacksquare \text{ Pa}$$

### d - Failure Pressures

$$p_{cLr} := \eta \cdot \alpha_{\theta L} \cdot p_{eL}$$

$$p_{cLr} = \blacksquare \text{ psi}$$

\*\*Value not calculated  
(Mx outside limits)



## 4.2 - General Instability of Ring Stiffened Cylinders

### 4.2.1 - Axial Compression or Bending

#### a - Elastic Buckling Stresses

$$A_{rb} := \frac{A_r}{L_r \cdot t}$$

$$\alpha_{xL} := \begin{cases} 0.207 & \text{if } \frac{D}{t} \geq 1242 \\ \frac{(169)}{195 + 0.5 \cdot \left(\frac{D}{t}\right)} & \text{if } \frac{D}{t} < 1242 \end{cases}$$

$$\alpha_{xG} := \begin{cases} 0.72 & \text{if } A_{rb} \geq 0.2 \\ \left[ \left( (3.6 - 5.0 \cdot \alpha_{xL}) \cdot A_{rb} + \alpha_{xL} \right) \right] & \text{if } 0.06 < A_{rb} < 0.2 \\ \alpha_{xL} & \text{if } A_{rb} \leq 0.06 \end{cases}$$

$$F_{xeGr} := \alpha_{xG} \cdot 0.605 E \cdot \left(\frac{t}{R}\right) \cdot (1 + A_{rb})^{\frac{1}{2}}$$

$$F_{xeGr} = 2.074 \times 10^9 \text{ Pa}$$

#### c - Inelastic Buckling Stresses

$$\Delta c := \frac{F_{xeGr}}{F_y}$$

$$\eta := \begin{cases} 1 & \text{if } \Delta c \leq 0.55 \\ \left( \frac{0.45}{\Delta c} + 0.18 \right) & \text{if } 0.55 < \Delta c \leq 1.6 \\ \frac{1.31}{1 + 1.15 \Delta c} & \text{if } 1.6 < \Delta c < 6.25 \\ \frac{1}{\Delta c} & \text{if } \Delta c \geq 6.25 \end{cases}$$

$$F_{xcGr} := \eta \cdot F_{xeGr}$$

$$F_{xcGr} = 8.482 \times 10^8 \text{ Pa}$$

#### 4.2.2 - External Pressure

a - Buckling Stresses With or Without End Pressure

$$L_e := \begin{cases} (1.1\sqrt{D \cdot t} + t_w) & \text{if } M_x > 1.56 \\ L_T & \text{if } M_x \leq 1.56 \end{cases}$$

$$I_{er} := I_T + A_T \cdot Z_T^2 \cdot \frac{L_e \cdot t}{A_T + L_e \cdot t} + \frac{L_e \cdot t^3}{12}$$

$$\lambda_G := \frac{\pi R}{L_b}$$

$$p_{eG}(n) := \frac{E \cdot \left(\frac{t}{R}\right) \cdot \lambda_G^4}{\left(n^2 + k \cdot \lambda_G^2 - 1\right) \cdot \left(n^2 + \lambda_G^2\right)^2} + \frac{E \cdot I_{er} \cdot (n^2 - 1)}{L_T \cdot R_c^2 \cdot R_0}$$

$$n := 6$$

Given

$$2 \leq n < 15$$

$$n_1 := \text{Minimize}(p_{eG}, n)$$

$$n_1 = 2$$

$$p_{eG}(n_1) = 9287.46 \text{ psi}$$

$$K_{\theta G} := (1 - 0.3k) \cdot \frac{L_e \cdot t}{A_T + L_e \cdot t}$$

$$\alpha_{\theta G} := 0.8$$

$$F_{reGr} := \alpha_{\theta G} \cdot \frac{p_{eG}(n_1) \cdot R_0}{t} \cdot K_{\theta G}$$

$$F_{reGr} = 1.48 \times 10^9 \text{ Pa}$$

### c - Inelastic Buckling Stresses

$$\Delta c := \frac{F_{reGr}}{F_y}$$

$$\eta := \begin{cases} 1 & \text{if } \Delta c \leq 0.55 \\ \left( \frac{0.45}{\Delta c} + 0.18 \right) & \text{if } 0.55 < \Delta c \leq 1.6 \\ \frac{1.31}{1 + 1.15 \Delta c} & \text{if } 1.6 < \Delta c < 6.25 \\ \frac{1}{\Delta c} & \text{if } \Delta c \geq 6.25 \end{cases}$$

$$F_{rcGr} := \eta \cdot F_{reGr}$$

$$F_{rcGr} = 7.53 \times 10^8 \text{ Pa}$$

### d - Failure Pressures

$$p_{cGr} := \eta \cdot \alpha_{\theta G} p_{eG}(n_1)$$

$$p_{cGr} = 3784.03 \text{ psi}$$

## RESULTS

### 4.1 - Local Buckling of Unstiffened or Ring Stiffened Cylinders

#### 4.1.1 - Axial Compression or Bending

##### a - Elastic Buckling Stresses

$$F_{xeLr} = 3.969 \times 10^9 \text{ Pa} \quad F_{xeLr} = 3.969 \times 10^9 \text{ Pa}$$

##### b - Inelastic Buckling Stresses

$$F_{xcLr} = 1.136 \times 10^9 \text{ Pa} \quad F_{xcLr} = 1.136 \times 10^9 \text{ Pa}$$

#### 4.1.2 - External Pressure

##### a - Elastic Buckling Stresses

$$F_{reLr} = \blacksquare \text{ Pa} \quad F_{reLr} = \blacksquare \text{ Pa}$$

##### c - Inelastic Buckling Stresses

$$F_{rcLr} = \blacksquare \text{ Pa} \quad F_{rcLr} = \blacksquare \text{ Pa}$$

##### d - Failure Pressures

$$p_{cLr} = \blacksquare \text{ Pa} \quad p_{cLr} = \blacksquare \text{ psi} \quad \text{**Value not calculated (Mx outside limits)}$$

### 4.2 - General Instability of Ring Stiffened Cylinders

#### 4.2.1 - Axial Compression or Bending

##### a - Elastic Buckling Stresses

$$F_{xeGr} = 2.074 \times 10^9 \text{ Pa} \quad F_{xeGr} = 2.074 \times 10^9 \text{ Pa}$$

##### c - Inelastic Buckling Stresses

$$F_{xcGr} = 8.482 \times 10^8 \text{ Pa} \quad F_{xcGr} = 8.482 \times 10^8 \text{ Pa}$$

#### 4.2.2 - External Pressure

##### a - Buckling Stresses With or Without End Pressure

$$F_{reGr} = 1.479 \times 10^9 \text{ Pa} \quad F_{reGr} = 1.479 \times 10^9 \text{ Pa}$$

##### c - Inelastic Buckling Stresses

$$F_{rcGr} = 7.534 \times 10^8 \text{ Pa} \quad F_{rcGr} = 7.534 \times 10^8 \text{ Pa}$$

##### d - Failure Pressures

$$p_{cGr} = 2.609 \times 10^7 \text{ Pa} \quad p_{cGr} = 3784.03 \text{ psi}$$

## **Appendix D: DNV (RP-C202) Solution**

Page Intentionally Left Blank

# Classification Society Solution (DNV-RP-C202)

Buckling Strength of Shells  
Oct 2002

## NAVSEA Test Cylinder 1.d

### General Definitions

$\text{ksi} := 6.89475710^6 \text{Pa}$	$\text{rtog} := 64.0 \frac{\text{lbft}}{\text{ft}^3}$	$\text{kip} := 1000 \text{bf}$	$\text{bload} := 1 \frac{\text{kip}}{\text{in}}$
$E := 30000 \text{ksi}$	Young's Modulus of Elasticity		$\text{kpa} := \frac{\text{kg}}{\text{sec}^2 \cdot \text{m}}$
$F_y := 80 \text{ksi}$	Yield Strength		
$\nu := .3$	Poisson's ratio for Fe/Steel		
$t := 0.08 \text{in}$	thickness of shell		
$R_i := 8.007 \text{in}$	Inner radius of cylinder		
$D_0 := 2 \cdot (R_i + t)$	diameter to outside of shell	$D_0 = 16.176 \text{in}$	
$L_r := 4.266 \text{in}$	ring spacing (frame center to frame center)		
$L_b := 22.488 \text{in}$	length of cylinder between bulkheads or lines of support		

### Ring Stiffener Dimensions

$t_w := 0.138 \text{in}$	thickness of web of ring stiffener	$t_w = 0.138 \text{in}$
$h_w := 0.57 \text{in}$	height of web of ring stiffener	$h_w = 0.57 \text{in}$
$b := t_w$	faying width of stiffener (from P&S for I beam stiffener)	
$b_f := 0.0 \text{in}$	breadth of flange of ring stiffener	$b_f = 0 \text{in}$
$t_f := 0.0 \text{in}$	flange thickness of ring stiffener	$t_f = 0 \text{in}$

$$R_0 := \frac{D_0}{2} \quad \text{radius to outside of shell}$$

$$R := R_0 - \frac{t}{2} \quad \text{radius to centerline of shell} \quad R = 8.047\text{in}$$

$$c_1 := \frac{\frac{t_w \cdot h_w^2}{2} + t_f \cdot b_f \left( h_w + \frac{t_f}{2} \right)}{t_w \cdot h_w + t_f \cdot b_f} \quad \text{dist from shell to centroid} \quad c_1 = 0.285\text{in}$$

$$c_2 := h_w - c_1 \quad \text{dist from centroid to end of flange} \quad c_2 = 0.285\text{in}$$

$$Z_r := c_1 + \frac{t}{2} \quad \text{distance from centerline of shell to centroid of ring stiffener (positive outward)} \quad Z_r = 0.325\text{in}$$

$$R_r := R + Z_r \quad \text{radius to centroid of ring stiffener}$$

$$A_r := (t_w \cdot h_w + b_f \cdot t_f) \quad \text{cross-sectional area of ring stiffener} \quad A_r = 0.079\text{in}^2$$

$$L := L_r - b \quad \text{unsupported shell length} \quad L = 4.128\text{in}$$

$$I_r := \frac{1}{12} \cdot t_w \cdot h_w^3 + t_w \cdot h_w \left( c_1 - \frac{h_w}{2} \right)^2 + \frac{1}{12} \cdot b_f \cdot t_f^3 + b_f \cdot t_f \left( c_2 + \frac{t_f}{2} \right)^2$$

$$I_r = 2.13 \times 10^{-3} \text{in}^4 \quad \text{moment of inertia of ring stiffener about its centroidal axis}$$

Moment of Inertia Calculations for combined plate and stiffener

$$\theta := \sqrt[4]{3 \cdot (1 - \nu^2)} \cdot \frac{L}{\sqrt{R \cdot t}}$$

$$L_e := 1.56 \sqrt{R \cdot t} \cdot \left( \frac{\cosh(\theta) - \cos(\theta)}{\sinh(\theta) + \sin(\theta)} \right) \quad \text{effective shell length, [P\&S eqn 92]}$$

$$L_e = 1.255\text{in}$$

$$d := h_w + \frac{t}{2} + \frac{t_f}{2}$$



$$A_p := L_e \cdot t \quad A_w := t_w \cdot h_w \quad A_{fl} := t_f \cdot b_f \quad A_T := A_p + A_w + A_{fl}$$

$$C_1 := \frac{A_w \cdot \left( \frac{A_T}{3} - \frac{A_w}{4} \right) + A_{fl} \cdot A_p}{A_T^2} \quad C_2 := \frac{\left( \frac{A_w}{2} + A_p \right)}{A_T}$$

$$y_p := \frac{1}{2} \cdot t + d \cdot (1 - C_2)$$

$$y_f := \frac{1}{2} \cdot t_f + d \cdot C_2$$

$$I_e := A_T \cdot d^2 \cdot C_1 \quad \text{moment of inertia for combined plate/stiffener}$$

[Hughes eqn 8.3.6]

$$I_e = 0.007 \text{in}^4$$

$$R_c := R - \frac{t}{2} + y_p \quad \text{radius to centroidal axis of combined ring stiffener and effective width of shell} \quad R_c = 8.181 \text{in}$$

**(outside stiffener -/+, inside +/-)**

# Failure Modes

## 3.5 Ring stiffened shells

### 3.5.1 General

The buckling modes to be checked are:

- a) Shell buckling, see Section 3.4.2.
- b) Panel ring buckling, see Section 3.5.2.
- c) Column buckling, see Section 3.8. - *(not applicable for these cylinders)*

### 3.4.2 Shell buckling

$$\psi := 2 \quad \rho := .6 \quad Z_1 := \frac{L_T^2}{R \cdot t} \cdot \sqrt{1 - \nu^2}$$

Buckling coefficients for hydrostatic pressure (Table 3.4-1)

$$\xi := 1.04 \sqrt{Z_1}$$

$$C_{SB} := \psi \cdot \sqrt{1 + \left( \frac{\rho \cdot \xi}{\psi} \right)^2} \quad (3.4.2)$$

$$f_E := \frac{C_{SB} \pi^2 \cdot E}{12 \cdot (1 - \nu^2)} \cdot \left( \frac{t}{L_T} \right)^2$$

Elastic buckling strength of unstiffened shell (3.4.1)  $f_E = 2.555 \times 10^8 \text{ Pa}$

$$f_{Eh} := f_E \quad f_{Ea} := f_E$$

$$l_{eo} := 1.56 \sqrt{R \cdot t}$$

$$\alpha := \frac{A_T}{l_{eo} \cdot t} \quad \beta := \frac{L_T}{1.56 \sqrt{R \cdot t}}$$

$$\xi_m := 2 \cdot \frac{\sinh(\beta) \cdot \cos(\beta) + \cosh(\beta) \cdot \sin(\beta)}{\sinh(2 \cdot \beta) + \sin(2 \cdot \beta)} \quad (2.2.10)$$

$$\xi_{t\_m} := \begin{cases} \xi_m & \text{if } \xi_m \geq 0 \\ 0 & \text{if } \xi_m < 0 \end{cases}$$

```

Psd_SB := | press ← 100·psi
           | limit ← 5·psi
           | test ← 0·psi
           | convert ← 1·psi
           | j ← 0
           | while j ≤ 40
           |   |  $\sigma_{a\_sd} \leftarrow \frac{-press \cdot R}{2 \cdot t}$  (2.2.2)
           |   |  $\sigma_{h\_sd} \leftarrow \frac{-press \cdot R}{t} \cdot \left[ 1 - \frac{\alpha \cdot \left( 1 - \frac{v}{2} \right) \cdot \xi_{t\_m}}{\alpha + 1} \right]$  (2.2.14)
           |   |  $\sigma_{j\_sd} \leftarrow \left( \sigma_{a\_sd}^2 - \sigma_{a\_sd} \cdot \sigma_{h\_sd} + \sigma_{h\_sd}^2 \right)^{\frac{1}{2}}$  (3.2.3)
           |   |  $\lambda_{s\_square} \leftarrow \frac{F_y}{\sigma_{j\_sd}} \cdot \left( \frac{-\sigma_{a\_sd}}{f_{Ea}} + \frac{-\sigma_{h\_sd}}{f_{Eh}} \right)$  (3.2.2)
           |   |  $f_{ks} \leftarrow \frac{F_y}{\sqrt{1 + \lambda_{s\_square}^2}}$  (3.2.1)
           |   |  $\lambda_s \leftarrow \sqrt{\lambda_{s\_square}}$ 
           |   |  $\gamma_m \leftarrow \begin{cases} 1.15 & \text{if } \lambda_s < 0.5 \\ (0.85 + 0.6 \lambda_s) & \text{if } 0.5 \leq \lambda_s \leq 1.0 \\ 1.45 & \text{if } \lambda_s > 1.0 \end{cases}$  (3.1.3)
           |   |  $f_{ksd} \leftarrow \frac{f_{ks}}{\gamma_m}$  (3.1.2)
           |   | break if  $\sigma_{j\_sd} > f_{ksd}$  (3.1.1)
           |   | press ← press + 2·psi
           |   | j ← j + 1
           |   | out0 ←  $\frac{press}{convert}$ 
           |   | out1 ← j
           |   | out2 ←  $\lambda_s$ 
           | out

```

$$P_{sd\_SB} = \begin{pmatrix} 166 \\ 33 \\ 1.934 \end{pmatrix}$$

$$P_{sd\_L} := P_{sd\_SB_0} \cdot 1\text{psi} - 2\text{psi}$$

$$P_{sd\_L} = 164\text{psi}$$

Maximum pressure to still meet stability requirement of eqn. 3.1.1.  
Prevent shell shell buckling (Local Buckling)

### 3.5.2 Panel ring buckling

#### 3.5.2.1 Cross sectional area check

The cross sectional area of a ring frame (exclusive of effective shell plate flange) should not be less than  $A_{req}$ , which is defined by:

$$Z_L := \frac{L_b^2}{R \cdot t} \cdot \sqrt{1 - \nu^2}$$

$$A_{Req} := \left( \frac{2}{Z_L^2} + 0.06 \right) \cdot L_r \cdot t \quad (3.5.1)$$

$$A_{Req} = 0.021\text{in}^2$$

required area

$$A_r = 0.079\text{in}^2$$

actual area

### 3.5.2.7 Refined calculation of $I_h$ for external pressure

Method for calculating the the capacity of the ring frame

If a ring stiffened cylinder, or a part of a ring stiffened cylinder, is effectively supported at the ends, the following procedure may be used to calculate required moment of inertia.

Moment of inertia for the combined plate/stiffener previously calculated [Hughes eqn 8.3.6]

$$I_h := I_e \quad I_h = 0.00658 \text{in}^4$$

$$f_r := F_y \quad \text{characteristic material strength (yield strength)}$$

$$Z_t := y_f$$

$$\zeta_o := 0.005R$$

$$l_{eo\_min} := \left( \begin{array}{c} 1.56\sqrt{R \cdot t} \\ L_r \end{array} \right)$$

$$l_{eo} := \min(l_{eo\_min}) \quad \text{equivalent length} \quad l_{eo} = 1.259 \text{in}$$

$$\alpha := \frac{A_r}{l_{eo} \cdot t} \quad (3.5.24)$$

$$r_r := \frac{D_0}{2}$$

$$r_f := R + \frac{t}{2} + h_w + t_f \quad \text{radius of shell measured to ring flange}$$

**(external stiffeners + + + / internal - - - )**

$$\lambda_s := P_{sd\_SB_2}$$

$$\gamma_m := \begin{cases} 1.15 & \text{if } \lambda_s < 0.5 \\ (0.85 + 0.60\lambda_s) & \text{if } 0.5 \leq \lambda_s \leq 1.0 \\ 1.45 & \text{if } \lambda_s > 1.0 \end{cases} \quad \text{material factor from sec 3.1} \quad (3.1.3)$$

$$\gamma_m = 1.45$$

$$i_{h\_square} := \frac{I_h}{A_r + l_{eo} \cdot t} \quad i_{h\_square} = 0.036 \text{ in}^2 \quad (3.5.27)$$

$$\alpha_B := \frac{12 \cdot (1 - \nu^2) \cdot I_h}{L_r \cdot t^3} \quad \alpha_B = 31.671 \quad (3.5.23)$$

$$C_1 := \frac{2 \cdot (1 + \alpha_B)}{1 + \alpha} \cdot \left( \sqrt{1 + \frac{0.27 \cdot Z_L}{\sqrt{1 + \alpha_B}}} - \frac{\alpha_B}{1 + \alpha_B} \right) \quad C_1 = 185.478 \quad (3.5.21)$$

$$C_2 := 2 \cdot \sqrt{1 + 0.27 \cdot Z_L} \quad C_2 = 28.342 \quad (3.5.28)$$

$$\mu := \frac{Z_t \cdot \zeta_o \cdot r_f \cdot L_r}{i_{h\_square} \cdot R \cdot l_{eo}} \cdot \left( 1 - \frac{C_2}{C_1} \right) \cdot \frac{1}{1 - \frac{\nu}{2}} \quad \mu = 1.917 \quad (3.5.25)$$

$$f_E := C_1 \cdot \frac{\pi^2 \cdot E}{12 \cdot (1 - \nu^2)} \cdot \left( \frac{t}{L_b} \right) \quad f_E = 1.811 \times 10^7 \text{ psi} \quad (3.5.20)$$

$$\lambda_1 := \sqrt{\frac{f_r}{f_E}} \quad \lambda_1 = 0.066 \quad (3.5.16)$$

$$f_k := (f_r) \cdot \frac{1 + \mu + \lambda_1^2 - \sqrt{(1 + \mu + \lambda_1^2)^2 - 4 \cdot \lambda_1^2}}{2 \cdot \lambda_1^2} \quad f_k = 2.74 \times 10^4 \text{ psi} \quad (3.5.15)$$

$$P_{sd\_GI} := 0.75 \cdot \frac{f_k}{\gamma_m} \cdot t \cdot r_f \cdot \frac{\left( 1 + \frac{A_r}{l_{eo} \cdot t} \right)}{R^2 \cdot \left( 1 - \frac{\nu}{2} \right)} \quad (3.5.14)$$

$P_{sd\_GI} = 319.755 \text{ psi}$

maximum allowed external pressure to prevent par ring buckling (General Instability)

## SUMMARY

### 3.5 Ring stiffened shells

#### 3.5.1 General

The buckling modes to be checked are:

- a) Shell buckling, see Section 3.4.2.
- b) Panel ring buckling, see Section 3.5.2.
- c) Column buckling, see Section 3.8. - *(not applicable for these cylinders)*

#### 3.4.2 Shell buckling (Elastic local buckling of unstiffened shell)

$$P_{sd\_L} = 164 \text{psi}$$

#### 3.5.2 Panel ring buckling

##### 3.5.2.1 Cross sectional area check

The cross sectional area of a ring frame (exclusive of effective shell plate flange) should not be less than  $A_{req}$ , which is defined by:

$$A_{Req} = 0.021 \text{in}^2$$

required area

$$A_r = 0.079 \text{in}^2$$

actual area

##### 3.5.2.7 Refined calculation of $I_h$ for external pressure (General Instability)

$$P_{sd\_GI} = 319.755 \text{psi}$$

Page Intentionally Left Blank



# Classification Society Solution (DNV-RP-C202)

Buckling Strength of Shells  
Oct 2002

## NAVSEA Test Cylinder 1.f

### General Defintions

$$\text{ksi} := 6.89475710^6 \text{ Pa}$$

$$\text{rtog} := 64.0 \frac{\text{lbft}}{\text{ft}^3}$$

$$\text{kip} := 1000 \text{bf}$$

$$\text{bload} := 1 \frac{\text{kip}}{\text{in}}$$

$$E := 30000 \text{ ksi}$$

Young's Modulus of Elasticity

$$\text{kpa} := \frac{\text{kg}}{\text{sec}^2 \cdot \text{m}}$$

$$F_y := 98.5 \text{ ksi}$$

Yield Strength

$$\nu := .3$$

Poison's ratio for Fe/Steel

$$t := 0.263 \text{ in}$$

thickness of shell

$$R_i := 17.197 \text{ in}$$

Inner radius of cylinder

$$D_0 := 2 \cdot (R_i + t)$$

diameter to outside of shell

$$D_0 = 34.92 \text{ in}$$

$$L_T := 2.666 \text{ in}$$

ring spacing (frame center to frame center)

$$L_b := 42.129 \text{ in}$$

length of cylinder between bulkheads or lines of support

### Ring Stiffener Dimensions

$$t_w := 0.198 \text{ in}$$

thickness of web of ring stiffener

$$t_w = 0.198 \text{ in}$$

$$h_w := 0.762 \text{ in}$$

height of web of ring stiffener

$$h_w = 0.762 \text{ in}$$

$$b := t_w$$

faying width of stiffener (from P&S for I beam stiffener)

$$b_f := 0.763 \text{ in}$$

breadth of flange of ring stiffener

$$b_f = 0.763 \text{ in}$$

$$t_f := 0.263 \text{ in}$$

flange thickness of ring stiffener

$$t_f = 0.263 \text{ in}$$

$$R_0 := \frac{D_0}{2} \quad \text{radius to outside of shell}$$

$$R := R_0 - \frac{t}{2} \quad \text{radius to centerline of shell} \quad R = 17.328\text{in}$$

$$c_1 := \frac{\frac{t_w \cdot h_w^2}{2} + t_f \cdot b_f \left( h_w + \frac{t_f}{2} \right)}{t_w \cdot h_w + t_f \cdot b_f} \quad \text{dist from shell to centroid} \quad c_1 = 0.674\text{in}$$

$$c_2 := h_w - c_1 \quad \text{dist from centroid to end of flange} \quad c_2 = 0.088\text{in}$$

$$Z_r := \left( c_1 + \frac{t}{2} \right) \cdot (-1) \quad \text{distance from centerline of shell to centroid of ring stiffener (positive outward)} \quad Z_r = -0.805\text{in}$$

$$R_r := R + Z_r \quad \text{radius to centroid of ring stiffener}$$

$$A_r := (t_w \cdot h_w + b_f \cdot t_f) \quad \text{cross-sectional area of ring stiffener} \quad A_r = 0.352\text{in}^2$$

$$L := L_r - b \quad \text{unsupported shell length} \quad L = 2.468\text{in}$$

$$I_r := \frac{1}{12} \cdot t_w \cdot h_w^3 + t_w \cdot h_w \cdot \left( c_1 - \frac{h_w}{2} \right)^2 + \frac{1}{12} \cdot b_f \cdot t_f^3 + b_f \cdot t_f \cdot \left( c_2 + \frac{t_f}{2} \right)^2$$

$$I_r = 0.031\text{in}^4 \quad \text{moment of inertia of ring stiffener about its centroidal axis}$$

Moment of Inertia Calculations for combined plate and stiffener

$$\theta := \sqrt[4]{3 \cdot (1 - \nu^2)} \cdot \frac{L}{\sqrt{R \cdot t}}$$

$$L_e := 1.56 \sqrt{R \cdot t} \cdot \left( \frac{\cosh(\theta) - \cos(\theta)}{\sinh(\theta) + \sin(\theta)} \right) \quad \text{effective shell length, [P\&S eqn 92]}$$

$$L_e = 2.41\text{in}$$

$$d := h_w + \frac{t}{2} + \frac{t_f}{2}$$

$$A_p := L_e \cdot t \quad A_w := t_w \cdot h_w \quad A_{fl} := t_f \cdot b_f \quad A_T := A_p + A_w + A_{fl}$$

$$C_1 := \frac{A_w \left( \frac{A_T}{3} - \frac{A_w}{4} \right) + A_{fl} \cdot A_p}{A_T^2} \quad C_2 := \frac{\left( \frac{A_w}{2} + A_p \right)}{A_T}$$

$$y_p := \frac{1}{2} \cdot t + d \cdot (1 - C_2) \quad y_f := \frac{1}{2} \cdot t_f + d \cdot C_2$$

$$I_e := A_T \cdot d^2 \cdot C_1 \quad \text{moment of inertia for combined plate/stiffener}$$

[Hughes eqn 8.3.6]

$$I_e = 0.182 \text{in}^4$$

$$R_c := R + \frac{t}{2} - y_p \quad \text{radius to centroidal axis of combined ring stiffener and effective width of shell} \quad R_c = 17.041 \text{in}$$

**(outside stiffener -/+, inside +/-)**

# Failure Modes

## 3.5 Ring stiffened shells

### 3.5.1 General

The buckling modes to be checked are:

- a) Shell buckling, see Section 3.4.2.
- b) Panel ring buckling, see Section 3.5.2.
- c) Column buckling, see Section 3.8. - *(not applicable for these cylinders)*

### 3.4.2 Shell buckling

$$\psi := 2 \quad \rho := .6 \quad Z_1 := \frac{L_T^2}{R \cdot t} \sqrt{1 - \nu^2}$$

Buckling coefficients for hydrostatic pressure (Table 3.4-1)

$$\xi := 1.04 \sqrt{Z_1}$$

$$C_{SB} := \psi \cdot \sqrt{1 + \left( \frac{\rho \cdot \xi}{\psi} \right)^2} \quad (3.4.2)$$

$$f_E := \frac{C_{SB} \pi^2 \cdot E}{12 \cdot (1 - \nu^2)} \cdot \left( \frac{t}{L_T} \right)^2$$

Elastic buckling strength of unstiffened shell (3.4.1)  $f_E = 3.893 \times 10^9 \text{ Pa}$

$$f_{Eh} := f_E \quad f_{Ea} := f_E$$

$$l_{eo} := 1.56 \sqrt{R \cdot t}$$

$$\alpha := \frac{A_T}{l_{eo} \cdot t} \quad \beta := \frac{L_T}{1.56 \sqrt{R \cdot t}}$$

$$\xi_m := 2 \cdot \frac{\sinh(\beta) \cdot \cos(\beta) + \cosh(\beta) \cdot \sin(\beta)}{\sinh(2 \cdot \beta) + \sin(2 \cdot \beta)} \quad (2.2.10)$$

$$\xi_{t\_m} := \begin{cases} \xi_m & \text{if } \xi_m \geq 0 \\ 0 & \text{if } \xi_m < 0 \end{cases}$$

```

Psd_SB := | press ← 1600 psi
           | limit ← 5·psi
           | test ← 0·psi
           | convert ← 1·psi
           | j ← 0
           | while j ≤ 100
           |   |  $\sigma_{a\_sd} \leftarrow \frac{-\text{press} \cdot R}{2 \cdot t}$  (2.2.2)
           |   |  $\sigma_{h\_sd} \leftarrow \frac{-\text{press} \cdot R}{t} \cdot \left[ 1 - \frac{\alpha \cdot \left( 1 - \frac{\nu}{2} \right) \cdot \xi_{t\_m}}{\alpha + 1} \right]$  (2.2.14)
           |   |  $\sigma_{j\_sd} \leftarrow \left( \sigma_{a\_sd}^2 - \sigma_{a\_sd} \cdot \sigma_{h\_sd} + \sigma_{h\_sd}^2 \right)^{\frac{1}{2}}$  (3.2.3)
           |   |  $\lambda_{s\_square} \leftarrow \frac{F_y}{\sigma_{j\_sd}} \cdot \left( \frac{-\sigma_{a\_sd}}{f_{Ea}} + \frac{-\sigma_{h\_sd}}{f_{Eh}} \right)$  (3.2.2)
           |   |  $f_{ks} \leftarrow \frac{F_y}{\sqrt{1 + \lambda_{s\_square}^2}}$  (3.2.1)
           |   |  $\lambda_s \leftarrow \sqrt{\lambda_{s\_square}}$ 
           |   |  $\gamma_m \leftarrow \begin{cases} 1.15 & \text{if } \lambda_s < 0.5 \\ (0.85 + 0.6 \lambda_s) & \text{if } 0.5 \leq \lambda_s \leq 1.0 \\ 1.45 & \text{if } \lambda_s > 1.0 \end{cases}$  (3.1.3)
           |   |  $f_{ksd} \leftarrow \frac{f_{ks}}{\gamma_m}$  (3.1.2)
           |   | break if  $\sigma_{j\_sd} > f_{ksd}$  (3.1.1)
           |   | press ← press + 2·psi
           |   | j ← j + 1
           |   | out0 ←  $\frac{\text{press}}{\text{convert}}$ 
           |   | out1 ← j
           |   | out2 ←  $\lambda_s$ 
           | out

```

$$P_{sd\_SB} = \begin{pmatrix} 1.756 \times 10^3 \\ 78 \\ 0.572 \end{pmatrix}$$

$$P_{sd\_L} := P_{sd\_SB}_0 \cdot 1\text{psi} - 2\text{psi}$$

$$P_{sd\_L} = 1754\text{psi}$$

Maximum pressure to still meet stability  
requirement of eqn. 3.1.1.  
Prevent shell shell buckling (Local Buckling)

### 3.5.2 Panel ring buckling

#### 3.5.2.1 Cross sectional area check

The cross sectional area of a ring frame (exclusive of effective shell plate flange) should not be less than  $A_{req}$ , which is defined by:

$$Z_L := \frac{L_b^2}{R \cdot t} \cdot \sqrt{1 - \nu^2}$$

$$A_{Req} := \left( \frac{2}{Z_L^2} + 0.06 \right) \cdot L_r \cdot t \quad (3.5.1)$$

$$A_{Req} = 0.042\text{in}^2$$

required area

$$A_r = 0.352\text{in}^2$$

actual area

### 3.5.2.7 Refined calculation of $I_h$ for external pressure

Method for calculating the the capacity of the ring frame

If a ring stiffened cylinder, or a part of a ring stiffened cylinder, is effectively supported at the ends, the following procedure may be used to calculate required moment of inertia.

Moment of inertia for the combined plate/stiffener previously calculated [Hughes eqn 8.3.6]

$$I_h := I_e \quad I_h = 0.18238 \text{in}^4$$

$$f_r := F_y \quad \text{characteristic material strength (yield strength)}$$

$$Z_t := y_f$$

$$\zeta_o := 0.005 R$$

$$l_{eo\_min} := \begin{pmatrix} 1.56\sqrt{R \cdot t} \\ L_r \end{pmatrix}$$

$$l_{eo} := \min(l_{eo\_min}) \quad \text{equivalent length} \quad l_{eo} = 2.666 \text{in}$$

$$\alpha := \frac{A_r}{l_{eo} \cdot t} \quad (3.5.24)$$

$$r_r := \frac{D_0}{2}$$

$$r_f := R - \frac{t}{2} - h_w - t_f \quad \text{radius of shell measured to ring flange}$$

**(external stiffeners + + + / internal - - - )**

$$\lambda_s := p_{sd\_SB_2}$$

$$\gamma_m := \begin{cases} 1.15 & \text{if } \lambda_s < 0.5 \\ (0.85 + 0.60\lambda_s) & \text{if } 0.5 \leq \lambda_s \leq 1.0 \\ 1.45 & \text{if } \lambda_s > 1.0 \end{cases} \quad \text{material factor from sec 3.1} \quad (3.1.3)$$

$$\gamma_m = 1.193$$

$$i_{h\_square} := \frac{I_h}{A_r + l_{eo} \cdot t} \quad i_{h\_square} = 0.173 \text{ in}^2 \quad (3.5.27)$$

$$\alpha_B := \frac{12 \cdot (1 - \nu^2) \cdot I_h}{L_r \cdot t^3} \quad \alpha_B = 41.065 \quad (3.5.23)$$

$$C_1 := \frac{2 \cdot (1 + \alpha_B)}{1 + \alpha} \cdot \left( \sqrt{1 + \frac{0.27 \cdot Z_L}{\sqrt{1 + \alpha_B}}} - \frac{\alpha_B}{1 + \alpha_B} \right) \quad C_1 = 172.677 \quad (3.5.21)$$

$$C_2 := 2 \cdot \sqrt{1 + 0.27 \cdot Z_L} \quad C_2 = 20.13 \quad (3.5.28)$$

$$\mu := \frac{Z_t \cdot \zeta_o \cdot r_f \cdot L_r}{i_{h\_square} \cdot R \cdot l_{eo}} \cdot \left( 1 - \frac{C_2}{C_1} \right) \cdot \frac{1}{1 - \frac{\nu}{2}} \quad \mu = 0.422 \quad (3.5.25)$$

$$f_E := C_1 \cdot \frac{\pi^2 \cdot E}{12 \cdot (1 - \nu^2)} \cdot \left( \frac{t}{L_b} \right) \quad f_E = 2.923 \times 10^7 \text{ psi} \quad (3.5.20)$$

$$\lambda_1 := \sqrt{\frac{f_r}{f_E}} \quad \lambda_1 = 0.058 \quad (3.5.16)$$

$$f_k := (f_r) \cdot \frac{1 + \mu + \lambda_1^2 - \sqrt{(1 + \mu + \lambda_1^2)^2 - 4 \cdot \lambda_1^2}}{2 \cdot \lambda_1^2} \quad (3.5.15)$$

$$f_k = 6.924 \times 10^4 \text{ psi}$$

$$P_{sd\_GI} := 0.75 \cdot \frac{f_k}{\gamma_m} \cdot t \cdot r_f \cdot \frac{\left( 1 + \frac{A_r}{l_{eo} \cdot t} \right)}{R^2 \cdot \left( 1 - \frac{\nu}{2} \right)} \quad (3.5.14)$$

$$P_{sd\_GI} = 1088.83 \text{ psi}$$

maximum allowed external pressure to prevent par ring buckling (General Instability)



## SUMMARY

### 3.5 Ring stiffened shells

#### 3.5.1 General

The buckling modes to be checked are:

- a) Shell buckling, see Section 3.4.2.
- b) Panel ring buckling, see Section 3.5.2.
- c) Column buckling, see Section 3.8. - *(not applicable for these cylinders)*

#### 3.4.2 Shell buckling (Elastic local buckling of unstiffened shell)

$$P_{sd\_L} = 1754 \text{psi}$$

#### 3.5.2 Panel ring buckling

##### 3.5.2.1 Cross sectional area check

The cross sectional area of a ring frame (exclusive of effective shell plate flange) should not be less than  $A_{req}$ , which is defined by:

$$A_{Req} = 0.042 \text{in}^2$$

required area

$$A_r = 0.352 \text{in}^2$$

actual area

##### 3.5.2.7 Refined calculation of $I_h$ for external pressure (General Instability)

$$P_{sd\_GI} = 1088.83 \text{psi}$$

Page Intentionally Left Blank

# Classification Society Solution (DNV-RP-C202)

Buckling Strength of Shells  
Oct 2002

## NAVSEA Test Cylinder 2.a

### General Definitions

$\text{ksi} := 6.89475710^6 \text{ Pa}$	$\text{rtog} := 64.0 \frac{\text{lbf}}{\text{ft}^3}$	$\text{kip} := 1000 \text{ lbf}$	$\text{load} := 1 \frac{\text{kip}}{\text{in}}$
$E := 30000 \text{ ksi}$	Young's Modulus of Elasticity		$\text{kpa} := \frac{\text{kg}}{\text{sec}^2 \cdot \text{m}}$
$F_y := 65.5 \text{ ksi}$	Yield Strength		
$\nu := .3$	Poisson's ratio for Fe/Steel		
$t := 0.0858 \text{ in}$	thickness of shell		
$R_i := 8.375 \text{ in}$	Inner radius of cylinder		
$D_0 := 2 \cdot (R_i + t)$	diameter to outside of shell	$D_0 = 16.922 \text{ in}$	
$L_r := 1.366 \text{ in}$	ring spacing (frame center to frame center)		
$L_b := 8.636 \text{ in}$	length of cylinder between bulkheads or lines of support		

### Ring Stiffener Dimensions

$t_w := 0.044 \text{ in}$	thickness of web of ring stiffener	$t_w = 0.044 \text{ in}$
$h_w := 0.4539 \text{ in}$	height of web of ring stiffener	$h_w = 0.454 \text{ in}$
$b := t_w$	faying width of stiffener (from P&S for I beam stiffener)	
$b_f := 0.399 \text{ in}$	breadth of flange of ring stiffener	$b_f = 0.399 \text{ in}$
$t_f := 0.078 \text{ in}$	flange thickness of ring stiffener	$t_f = 0.078 \text{ in}$

$$R_0 := \frac{D_0}{2} \quad \text{radius to outside of shell}$$

$$R := R_0 - \frac{t}{2} \quad \text{radius to centerline of shell} \quad R = 8.418\text{in}$$

$$c_1 := \frac{\frac{t_w \cdot h_w^2}{2} + t_f \cdot b_f \left( h_w + \frac{t_f}{2} \right)}{t_w \cdot h_w + t_f \cdot b_f} \quad \text{dist from shell to centroid} \quad c_1 = 0.389\text{in}$$

$$c_2 := h_w - c_1 \quad \text{dist from centroid to end of flange} \quad c_2 = 0.065\text{in}$$

$$Z_r := c_1 + \frac{t}{2} \quad \text{distance from centerline of shell to centroid of ring stiffener (positive outward)} \quad Z_r = 0.432\text{in}$$

$$R_r := R + Z_r \quad \text{radius to centroid of ring stiffener}$$

$$A_r := (t_w \cdot h_w + b_f \cdot t_f) \quad \text{cross-sectional area of ring stiffener} \quad A_r = 0.051\text{in}^2$$

$$L := L_r - b \quad \text{unsupported shell length} \quad L = 1.322\text{in}$$

$$I_r := \frac{1}{12} \cdot t_w \cdot h_w^3 + t_w \cdot h_w \cdot \left( c_1 - \frac{h_w}{2} \right)^2 + \frac{1}{12} \cdot b_f \cdot t_f^3 + b_f \cdot t_f \cdot \left( c_2 + \frac{t_f}{2} \right)^2$$

$$I_r = 1.219 \times 10^{-3} \text{in}^4 \quad \text{moment of inertia of ring stiffener about its centroidal axis}$$

Moment of Inertia Calculations for combined plate and stiffener

$$\theta := \sqrt[4]{3 \cdot (1 - \nu^2)} \cdot \frac{L}{\sqrt{R \cdot t}}$$

$$L_e := 1.56 \sqrt{R \cdot t} \cdot \left( \frac{\cosh(\theta) - \cos(\theta)}{\sinh(\theta) + \sin(\theta)} \right) \quad \text{effective shell length, [P\&S eqn 92]}$$

$$L_e = 1.221\text{in}$$

$$d := h_w + \frac{t}{2} + \frac{t_f}{2}$$

$$A_p := L_e \cdot t \quad A_w := t_w \cdot h_w \quad A_{fl} := t_f \cdot b_f \quad A_T := A_p + A_w + A_{fl}$$

$$C_1 := \frac{A_w \cdot \left( \frac{A_T}{3} - \frac{A_w}{4} \right) + A_{fl} \cdot A_p}{A_T^2} \quad C_2 := \frac{\left( \frac{A_w}{2} + A_p \right)}{A_T}$$

$$y_p := \frac{1}{2} \cdot t + d \cdot (1 - C_2)$$

$$y_f := \frac{1}{2} \cdot t_f + d \cdot C_2$$

$$I_e := A_T \cdot d^2 \cdot C_1 \quad \text{moment of inertia for combined plate/stiffener}$$

[Hughes eqn 8.3.6]

$$I_e = 0.008 \text{in}^4$$

$$R_c := R - \frac{t}{2} + y_p \quad \text{radius to centroidal axis of combined ring stiffener and effective width of shell} \quad R_c = 8.559 \text{in}$$

**(outside stiffener -/+, inside +/-)**

# Failure Modes

## 3.5 Ring stiffened shells

### 3.5.1 General

The buckling modes to be checked are:

- a) Shell buckling, see Section 3.4.2.
- b) Panel ring buckling, see Section 3.5.2.
- c) Column buckling, see Section 3.8. - *(not applicable for these cylinders)*

### 3.4.2 Shell buckling

$$\psi := 2 \quad \rho := .6 \quad Z_1 := \frac{L_r^2}{R \cdot t} \sqrt{1 - \nu^2}$$

Buckling coefficients for hydrostatic pressure (Table 3.4-1)

$$\xi := 1.04 \sqrt{Z_1}$$

$$C_{SB} := \psi \cdot \sqrt{1 + \left( \frac{\rho \cdot \xi}{\psi} \right)^2} \quad (3.4.2)$$

$$f_E := \frac{C_{SB} \cdot \pi^2 \cdot E}{12 \cdot (1 - \nu^2)} \cdot \left( \frac{t}{L_r} \right)^2$$

Elastic buckling strength of unstiffened shell (3.4.1)  $f_E = 1.643 \times 10^9 \text{ Pa}$

$$f_{Eh} := f_E \quad f_{Ea} := f_E$$

$$l_{eo} := 1.56 \sqrt{R \cdot t}$$

$$\alpha := \frac{A_r}{l_{eo} \cdot t} \quad \beta := \frac{L_r}{1.56 \sqrt{R \cdot t}}$$

$$\xi_m := 2 \cdot \frac{\sinh(\beta) \cdot \cos(\beta) + \cosh(\beta) \cdot \sin(\beta)}{\sinh(2 \cdot \beta) + \sin(2 \cdot \beta)} \quad (2.2.10)$$

$$\xi_{t\_m} := \begin{cases} \xi_m & \text{if } \xi_m \geq 0 \\ 0 & \text{if } \xi_m < 0 \end{cases}$$

```

Psd_SB := | press ← 600·psi
           | limit ← 5·psi
           | test ← 0·psi
           | convert ← 1·psi
           | j ← 0
           | while j ≤ 40
           |   | σa_sd ←  $\frac{-\text{press} \cdot R}{2 \cdot t}$  (2.2.2)
           |   | σh_sd ←  $\frac{-\text{press} \cdot R}{t} \left[ 1 - \frac{\alpha \cdot \left( 1 - \frac{\nu}{2} \right) \cdot \xi_{t_m}}{\alpha + 1} \right]$  (2.2.14)
           |   | σj_sd ←  $\left( \sigma_{a\_sd}^2 - \sigma_{a\_sd} \cdot \sigma_{h\_sd} + \sigma_{h\_sd}^2 \right)^{\frac{1}{2}}$  (3.2.3)
           |   | λs_square ←  $\frac{F_y}{\sigma_{j\_sd}} \cdot \left( \frac{-\sigma_{a\_sd}}{f_{Ea}} + \frac{-\sigma_{h\_sd}}{f_{Eh}} \right)$  (3.2.2)
           |   | fks ←  $\frac{F_y}{\sqrt{1 + \lambda_{s\_square}^2}}$  (3.2.1)
           |   | λs ←  $\sqrt{\lambda_{s\_square}}$ 
           |   | γm ←  $\begin{cases} 1.15 & \text{if } \lambda_s < 0.5 \\ (0.85 + 0.6 \lambda_s) & \text{if } 0.5 \leq \lambda_s \leq 1.0 \\ 1.45 & \text{if } \lambda_s > 1.0 \end{cases}$  (3.1.3)
           |   | fksd ←  $\frac{f_{ks}}{\gamma_m}$  (3.1.2)
           |   | break if σj_sd > fksd (3.1.1)
           |   | press ← press + 2·psi
           |   | j ← j + 1
           |   | out0 ←  $\frac{\text{press}}{\text{convert}}$ 
           |   | out1 ← j
           |   | out2 ← λs
           | out

```

$$p_{sd\_SB} = \begin{pmatrix} 678 \\ 39 \\ 0.717 \end{pmatrix}$$

$$p_{sd\_L} := p_{sd\_SB_0} \cdot 1\text{psi} - 2\text{psi}$$

$$p_{sd\_L} = 676\text{psi}$$

Maximum pressure to still meet stability requirement of eqn. 3.1.1.  
Prevent shell shell buckling (Local Buckling)

### 3.5.2 Panel ring buckling

#### 3.5.2.1 Cross sectional area check

The cross sectional area of a ring frame (exclusive of effective shell plate flange) should not be less than  $A_{req}$ , which is defined by:

$$Z_L := \frac{L_b^2}{R \cdot t} \cdot \sqrt{1 - \nu^2}$$

$$A_{Req} := \left( \frac{2}{Z_L^2} + 0.06 \right) \cdot L_r \cdot t \quad (3.5.1)$$

$$A_{Req} = 0.0071\text{in}^2$$

required area

$$A_r = 0.051\text{in}^2$$

actual area



### 3.5.2.7 Refined calculation of $I_h$ for external pressure

Method for calculating the the capacity of the ring frame

If a ring stiffened cylinder, or a part of a ring stiffened cylinder, is effectively supported at the ends, the following procedure may be used to calculate required moment of inertia.

Moment of inertia for the combined plate/stiffener previously calculated [Hughes eqn 8.3.6]

$$I_h := I_e \quad I_h = 0.00773 \text{in}^4$$

$$f_T := F_y \quad \text{characteristic material strength (yield strength)}$$

$$Z_t := y_f$$

$$\zeta_0 := 0.005 R$$

$$l_{eo\_min} := \left( \begin{array}{c} 1.56\sqrt{R \cdot t} \\ L_T \end{array} \right)$$

$$l_{eo} := \min(l_{eo\_min}) \quad \text{equivalent length} \quad l_{eo} = 1.326 \text{in}$$

$$\alpha := \frac{A_r}{l_{eo} \cdot t} \quad (3.5.24)$$

$$r_r := \frac{D_0}{2}$$

$$r_f := R + \frac{t}{2} + h_w + t_f \quad \text{radius of shell measured to ring flange}$$

**(external stiffeners + + + / internal - - - )**

$$\lambda_s := P_{sd\_SB_2}$$

$$\gamma_m := \begin{cases} 1.15 & \text{if } \lambda_s < 0.5 \\ (0.85 + 0.60\lambda_s) & \text{if } 0.5 \leq \lambda_s \leq 1.0 \\ 1.45 & \text{if } \lambda_s > 1.0 \end{cases} \quad \text{material factor from sec 3.1} \quad (3.1.3)$$

$$\gamma_m = 1.28$$

$$i_{h\_square} := \frac{I_h}{A_r + l_{eo} \cdot t} \quad i_{h\_square} = 0.047 \text{in}^2 \quad (3.5.27)$$

$$\alpha_B := \frac{12 \cdot (1 - \nu^2) \cdot I_h}{L_r \cdot t^3} \quad \alpha_B = 97.872 \quad (3.5.23)$$

$$C_1 := \frac{2 \cdot (1 + \alpha_B)}{1 + \alpha} \cdot \left( \sqrt{1 + \frac{0.27 \cdot Z_L}{\sqrt{1 + \alpha_B}}} - \frac{\alpha_B}{1 + \alpha_B} \right) \quad C_1 = 126.503 \quad (3.5.21)$$

$$C_2 := 2 \cdot \sqrt{1 + 0.27 \cdot Z_L} \quad C_2 = 10.506 \quad (3.5.28)$$

$$\mu := \frac{Z_t \cdot \zeta_o \cdot r_f \cdot L_r}{i_{h\_square} \cdot R \cdot l_{eo}} \cdot \left( 1 - \frac{C_2}{C_1} \right) \cdot \frac{1}{1 - \frac{\nu}{2}} \quad \mu = 0.462 \quad (3.5.25)$$

$$f_E := C_1 \cdot \frac{\pi^2 \cdot E}{12 \cdot (1 - \nu^2)} \cdot \left( \frac{t}{L_b} \right) \quad f_E = 3.408 \times 10^7 \text{psi} \quad (3.5.20)$$

$$\lambda_1 := \sqrt{\frac{f_r}{f_E}} \quad \lambda_1 = 0.044 \quad (3.5.16)$$

$$f_k := (f_r) \cdot \frac{1 + \mu + \lambda_1^2 - \sqrt{\left( (1 + \mu + \lambda_1^2)^2 - 4 \cdot \lambda_1^2 \right)}}{2 \cdot \lambda_1^2} \quad f_k = 4.479 \times 10^4 \text{psi} \quad (3.5.15)$$

$$P_{sd\_GI} := 0.75 \cdot \frac{f_k}{\gamma_m} \cdot t \cdot r_f \cdot \frac{\left( 1 + \frac{A_r}{l_{eo} \cdot t} \right)}{R^2 \cdot \left( 1 - \frac{\nu}{2} \right)} \quad (3.5.14)$$

$$P_{sd\_GI} = 487.078 \text{psi}$$

maximum allowed external pressure to prevent par ring buckling (General Instability)

## SUMMARY

### 3.5 Ring stiffened shells

#### 3.5.1 General

The buckling modes to be checked are:

- a) Shell buckling, see Section 3.4.2.
- b) Panel ring buckling, see Section 3.5.2.
- c) Column buckling, see Section 3.8. - *(not applicable for these cylinders)*

#### 3.4.2 Shell buckling (Elastic local buckling of unstiffened shell)

$$P_{sd\_L} = 676 \text{psi}$$

#### 3.5.2 Panel ring buckling

##### 3.5.2.1 Cross sectional area check

The cross sectional area of a ring frame (exclusive of effective shell plate flange) should not be less than  $A_{req}$ , which is defined by:

$$A_{Req} = 0.0071 \text{in}^2$$

required area

$$A_r = 0.051 \text{in}^2$$

actual area

##### 3.5.2.7 Refined calculation of $I_h$ for external pressure (General Instability)

$$P_{sd\_GI} = 487.08 \text{psi}$$

Page Intentionally Left Blank

# Classification Society Solution (DNV-RP-C202)

Buckling Strength of Shells  
Oct 2002

## NAVSEA Test Cylinder 2.c

### General Definitions

$\text{ksi} := 6.89475710^6 \text{ Pa}$	$\text{rtog} := 64.0 \frac{\text{lbf}}{\text{ft}^3}$	$\text{kip} := 1000 \text{ lbf}$	$\text{load} := 1 \frac{\text{kip}}{\text{in}}$
$E := 30000 \text{ ksi}$	Young's Modulus of Elasticity		$\text{kpa} := \frac{\text{kg}}{\text{sec}^2 \cdot \text{m}}$
$F_y := 157 \text{ ksi}$	Yield Strength		
$\nu := .3$	Poisson's ratio for Fe/Steel		
$t := 0.337 \text{ in}$	thickness of shell		
$R_i := 18.714 \text{ in}$	Inner radius of cylinder		
$D_0 := 2 \cdot (R_i + t)$	diameter to outside of shell	$D_0 = 38.102 \text{ in}$	
$L_r := 3.256 \text{ in}$	ring spacing (frame center to frame center)		
$L_b := 115.532 \text{ in}$	length of cylinder between bulkheads or lines of support		

### Ring Stiffener Dimensions

$t_w := 0.127 \text{ in}$	thickness of web of ring stiffener	$t_w = 0.127 \text{ in}$
$h_w := 2.01 \text{ in}$	height of web of ring stiffener	$h_w = 2.01 \text{ in}$
$b := t_w$	faying width of stiffener (from P&S for I beam stiffener)	
$b_f := 1.552 \text{ in}$	breadth of flange of ring stiffener	$b_f = 1.552 \text{ in}$
$t_f := 0.305 \text{ in}$	flange thickness of ring stiffener	$t_f = 0.305 \text{ in}$

$$R_0 := \frac{D_0}{2} \quad \text{radius to outside of shell}$$

$$R := R_0 - \frac{t}{2} \quad \text{radius to centerline of shell} \quad R = 18.883\text{in}$$

$$c_1 := \frac{\frac{t_w \cdot h_w^2}{2} + t_f \cdot b_f \left( h_w + \frac{t_f}{2} \right)}{t_w \cdot h_w + t_f \cdot b_f} \quad \text{dist from shell to centroid} \quad c_1 = 1.757\text{in}$$

$$c_2 := h_w - c_1 \quad \text{dist from centroid to end of flange} \quad c_2 = 0.253\text{in}$$

$$Z_r := \left( c_1 + \frac{t}{2} \right) \cdot (-1) \quad \text{distance from centerline of shell to centroid of ring stiffener (**positive outward**)} \quad Z_r = -1.925\text{in}$$

$$R_r := R + Z_r \quad \text{radius to centroid of ring stiffener}$$

$$A_r := (t_w \cdot h_w + b_f \cdot t_f) \quad \text{cross-sectional area of ring stiffener} \quad A_r = 0.729\text{in}^2$$

$$L := L_r - b \quad \text{unsupported shell length} \quad L = 3.129\text{in}$$

$$I_r := \frac{1}{12} \cdot t_w \cdot h_w^3 + t_w \cdot h_w \cdot \left( c_1 - \frac{h_w}{2} \right)^2 + \frac{1}{12} \cdot b_f \cdot t_f^3 + b_f \cdot t_f \cdot \left( c_2 + \frac{t_f}{2} \right)^2$$

$$I_r = 0.312\text{in}^4 \quad \text{moment of inertia of ring stiffener about its centroidal axis}$$

Moment of Inertia Calculations for combined plate and stiffener

$$\theta := \sqrt[4]{3 \cdot (1 - \nu^2)} \cdot \frac{L}{\sqrt{R \cdot t}}$$

$$L_e := 1.56 \sqrt{R \cdot t} \cdot \left( \frac{\cosh(\theta) - \cos(\theta)}{\sinh(\theta) + \sin(\theta)} \right) \quad \text{effective shell length, [P\&S eqn 92]}$$

$$L_e = 3.03\text{in}$$

$$d := h_w + \frac{t}{2} + \frac{t_f}{2}$$

$$A_p := L_e \cdot t \quad A_w := t_w \cdot h_w \quad A_{fl} := t_f \cdot b_f \quad A_T := A_p + A_w + A_{fl}$$

$$C_1 := \frac{A_w \cdot \left( \frac{A_T}{3} - \frac{A_w}{4} \right) + A_{fl} \cdot A_p}{A_T^2} \quad C_2 := \frac{\left( \frac{A_w}{2} + A_p \right)}{A_T}$$

$$y_p := \frac{1}{2} \cdot t + d \cdot (1 - C_2)$$

$$y_f := \frac{1}{2} \cdot t_f + d \cdot C_2$$

$$I_e := A_T \cdot d^2 \cdot C_1 \quad \text{moment of inertia for combined plate/stiffener}$$

[Hughes eqn 8.3.6]

$$I_e = 1.913 \text{in}^4$$

$$R_c := R + \frac{t}{2} - y_p \quad \text{radius to centroidal axis of combined ring stiffener and effective width of shell} \quad R_c = 18.082 \text{in}$$

**(outside stiffener -/+, inside +/-)**

# Failure Modes

## 3.5 Ring stiffened shells

### 3.5.1 General

The buckling modes to be checked are:

- a) Shell buckling, see Section 3.4.2.
- b) Panel ring buckling, see Section 3.5.2.
- c) Column buckling, see Section 3.8. - *(not applicable for these cylinders)*

### 3.4.2 Shell buckling

$$\psi := 2 \quad \rho := .6 \quad Z_1 := \frac{L_r^2}{R \cdot t} \sqrt{1 - \nu^2}$$

Buckling coefficients for hydrostatic pressure (Table 3.4-1)

$$\xi := 1.04 \sqrt{Z_1}$$

$$C_{SB} := \psi \cdot \sqrt{1 + \left( \frac{\rho \cdot \xi}{\psi} \right)^2} \quad (3.4.2)$$

$$f_E := \frac{C_{SB} \cdot \pi^2 \cdot E}{12 \cdot (1 - \nu^2)} \cdot \left( \frac{t}{L_r} \right)^2$$

Elastic buckling strength of unstiffened shell (3.4.1)  $f_E = 4.304 \times 10^9 \text{ Pa}$

$$f_{Eh} := f_E \quad f_{Ea} := f_E$$

$$l_{eo} := 1.56 \sqrt{R \cdot t}$$

$$\alpha := \frac{A_r}{l_{eo} \cdot t} \quad \beta := \frac{L_r}{1.56 \sqrt{R \cdot t}}$$

$$\xi_m := 2 \cdot \frac{\sinh(\beta) \cdot \cos(\beta) + \cosh(\beta) \cdot \sin(\beta)}{\sinh(2 \cdot \beta) + \sin(2 \cdot \beta)} \quad (2.2.10)$$

$$\xi_{t\_m} := \begin{cases} \xi_m & \text{if } \xi_m \geq 0 \\ 0 & \text{if } \xi_m < 0 \end{cases}$$



```

Psd_SB := | press ← 3100 psi
           | limit ← 5·psi
           | test ← 0·psi
           | convert ← 1·psi
           | j ← 0
           | while j ≤ 100
           |   |  $\sigma_{a\_sd} \leftarrow \frac{-\text{press} \cdot R}{2 \cdot t}$  (2.2.2)
           |   |  $\sigma_{h\_sd} \leftarrow \frac{-\text{press} \cdot R}{t} \cdot \left[ 1 - \frac{\alpha \cdot \left( 1 - \frac{\nu}{2} \right) \cdot \xi_{t\_m}}{\alpha + 1} \right]$  (2.2.14)
           |   |  $\sigma_{j\_sd} \leftarrow \left( \sigma_{a\_sd}^2 - \sigma_{a\_sd} \cdot \sigma_{h\_sd} + \sigma_{h\_sd}^2 \right)^{\frac{1}{2}}$  (3.2.3)
           |   |  $\lambda_{s\_square} \leftarrow \frac{F_y}{\sigma_{j\_sd}} \cdot \left( \frac{-\sigma_{a\_sd}}{f_{Ea}} + \frac{-\sigma_{h\_sd}}{f_{Eh}} \right)$  (3.2.2)
           |   |  $f_{ks} \leftarrow \frac{F_y}{\sqrt{1 + \lambda_{s\_square}^2}}$  (3.2.1)
           |   |  $\lambda_s \leftarrow \sqrt{\lambda_{s\_square}}$ 
           |   |  $\gamma_m \leftarrow \begin{cases} 1.15 & \text{if } \lambda_s < 0.5 \\ (0.85 + 0.6 \lambda_s) & \text{if } 0.5 \leq \lambda_s \leq 1.0 \\ 1.45 & \text{if } \lambda_s > 1.0 \end{cases}$  (3.1.3)
           |   |  $f_{ksd} \leftarrow \frac{f_{ks}}{\gamma_m}$  (3.1.2)
           |   | break if  $\sigma_{j\_sd} > f_{ksd}$  (3.1.1)
           |   | press ← press + 2·psi
           |   | j ← j + 1
           |   | out0 ←  $\frac{\text{press}}{\text{convert}}$ 
           |   | out1 ← j
           |   | out2 ←  $\lambda_s$ 
           | out

```

$$p_{sd\_SB} = \begin{pmatrix} 3.122 \times 10^3 \\ 11 \\ 0.693 \end{pmatrix}$$

$$p_{sd\_L} := p_{sd\_SB_0} \cdot 1\text{psi} - 2\text{psi}$$

$$p_{sd\_L} = 3120\text{psi}$$

Maximum pressure to still meet stability requirement of eqn. 3.1.1.  
Prevent shell shell buckling (Local Buckling)

### 3.5.2 Panel ring buckling

#### 3.5.2.1 Cross sectional area check

The cross sectional area of a ring frame (exclusive of effective shell plate flange) should not be less than  $A_{req}$ , which is defined by:

$$Z_L := \frac{L_b^2}{R \cdot t} \cdot \sqrt{1 - \nu^2}$$

$$A_{Req} := \left( \frac{2}{Z_L^2} + 0.06 \right) \cdot L_r \cdot t \quad (3.5.1)$$

$$A_{Req} = 0.066\text{in}^2$$

required area

$$A_r = 0.729\text{in}^2$$

actual area

### 3.5.2.7 Refined calculation of $I_h$ for external pressure

Method for calculating the the capacity of the ring frame

If a ring stiffened cylinder, or a part of a ring stiffened cylinder, is effectively supported at the ends, the following procedure may be used to calculate required moment of inertia.

Moment of inertia for the combined plate/stiffener previously calculated [Hughes eqn 8.3.6]

$$I_h := I_e \quad I_h = 1.91274 \text{in}^4$$

$$f_T := F_y \quad \text{characteristic material strength (yield strength)}$$

$$Z_t := y_f$$

$$\zeta_o := 0.005 R$$

$$l_{eo\_min} := \left( \begin{array}{c} 1.56\sqrt{R \cdot t} \\ L_T \end{array} \right)$$

$$l_{eo} := \min(l_{eo\_min}) \quad \text{equivalent length} \quad l_{eo} = 3.256 \text{in}$$

$$\alpha := \frac{A_r}{l_{eo} \cdot t} \quad (3.5.24)$$

$$r_r := \frac{D_0}{2}$$

$$r_f := R - \frac{t}{2} - h_w - t_f \quad \text{radius of shell measured to ring flange}$$

**(external stiffeners + + + / internal - - - )**

$$\lambda_s := p_{sd\_SB_2}$$

$$\gamma_m := \begin{cases} 1.15 & \text{if } \lambda_s < 0.5 \\ (0.85 + 0.60\lambda_s) & \text{if } 0.5 \leq \lambda_s \leq 1.0 \\ 1.45 & \text{if } \lambda_s > 1.0 \end{cases} \quad \text{material factor from sec 3.1} \quad (3.1.3)$$

$$\gamma_m = 1.266$$

$$i_{h\_square} := \frac{I_h}{A_r + l_{eo} \cdot t} \quad i_{h\_square} = 1.048 \text{ in}^2 \quad (3.5.27)$$

$$\alpha_B := \frac{12 \cdot (1 - \nu^2) \cdot I_h}{L_r \cdot t^3} \quad \alpha_B = 167.612 \quad (3.5.23)$$

$$C_1 := \frac{2 \cdot (1 + \alpha_B)}{1 + \alpha} \cdot \left( \sqrt{1 + \frac{0.27 \cdot Z_L}{\sqrt{1 + \alpha_B}}} - \frac{\alpha_B}{1 + \alpha_B} \right) \quad C_1 = 1.121 \times 10^3 \quad (3.5.21)$$

$$C_2 := 2 \cdot \sqrt{1 + 0.27 \cdot Z_L} \quad C_2 = 46.53 \quad (3.5.28)$$

$$\mu := \frac{Z_t \cdot \zeta_o \cdot r_f \cdot L_r}{i_{h\_square} \cdot R \cdot l_{eo}} \cdot \left( 1 - \frac{C_2}{C_1} \right) \cdot \frac{1}{1 - \frac{\nu}{2}} \quad \mu = 0.149 \quad (3.5.25)$$

$$f_E := C_1 \cdot \frac{\pi^2 \cdot E}{12 \cdot (1 - \nu^2)} \cdot \left( \frac{t}{L_b} \right) \quad f_E = 8.869 \times 10^7 \text{ psi} \quad (3.5.20)$$

$$\lambda_1 := \sqrt{\frac{f_r}{f_E}} \quad \lambda_1 = 0.042 \quad (3.5.16)$$

$$f_k := (f_r) \cdot \frac{1 + \mu + \lambda_1^2 - \sqrt{(1 + \mu + \lambda_1^2)^2 - 4 \cdot \lambda_1^2}}{2 \cdot \lambda_1^2} \quad (3.5.15)$$

$$f_k = 1.367 \times 10^5 \text{ psi}$$

$$P_{sd\_GI} := 0.75 \cdot \frac{f_k}{\gamma_m} \cdot t \cdot r_f \cdot \frac{\left( 1 + \frac{A_r}{l_{eo} \cdot t} \right)}{R^2 \cdot \left( 1 - \frac{\nu}{2} \right)} \quad (3.5.14)$$

$$P_{sd\_GI} = 2457.38 \text{ psi}$$

maximum allowed external pressure to prevent par ring buckling (General Instability)

## SUMMARY

### 3.5 Ring stiffened shells

#### 3.5.1 General

The buckling modes to be checked are:

- a) Shell buckling, see Section 3.4.2.
- b) Panel ring buckling, see Section 3.5.2.
- c) Column buckling, see Section 3.8. - *(not applicable for these cylinders)*

#### 3.4.2 Shell buckling (Elastic local buckling of unstiffened shell)

$$p_{sd\_L} = 3120 \text{psi}$$

#### 3.5.2 Panel ring buckling

##### 3.5.2.1 Cross sectional area check

The cross sectional area of a ring frame (exclusive of effective shell plate flange) should not be less than  $A_{req}$ , which is defined by:

$$A_{Req} = 0.066 \text{in}^2$$

required area

$$A_r = 0.729 \text{in}^2$$

actual area

##### 3.5.2.7 Refined calculation of $I_h$ for external pressure (General Instability)

$$p_{sd\_GI} = 2457.38 \text{psi}$$

Page Intentionally Left Blank