

Propositional Attitudes and Indexicality: A Cross-Categorical Approach

by
Philippe Schlenker

Agrégation de Philosophie (1994), École Normale Supérieure
DEA de Philosophie (1995), Université de Paris 10

Submitted to the Department of Linguistics and Philosophy
in Partial Fulfillment of the Requirements for the Degree of

Doctor of Philosophy in Linguistics
at the
Massachusetts Institute of Technology

September 1999

©1999 Philippe Schlenker. All rights reserved.

The author hereby grants to MIT permission to reproduce and to distribute publicly
paper and electronic copies of this thesis document in whole or in part.

Signature of Author: _____
Department of Linguistics and Philosophy
September 7, 1999

Certified by: _____
Irene Heim
Professor of Linguistics
Thesis Supervisor

Accepted by: _____
Alec Marantz
Professor of Linguistics
Head, Department of Linguistics and Philosophy

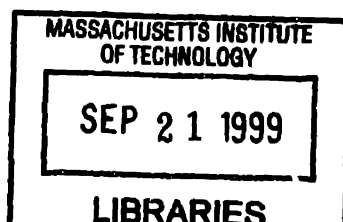

ARCHIVES

Propositional Attitudes and Indexicality: A Cross-Categorial Approach

by

Philippe Schlenker

Submitted to the Department of Linguistics and Philosophy on September 10, 1999
in Partial Fulfillment of the Requirements for the Degree of Doctor of Philosophy

ABSTRACT

Universal Grammar uses the same distinctions (features) and the same interpretive procedures for reference to individuals, times, and possible worlds. We give a partial argument for this hypothesis: person, tense and (maybe) mood can be treated on a par when they occur in reported speech. We consider several generalizations that hold across sortal domains, and develop a theory of propositional attitudes and indexicality that captures these facts, and treats all three categories on a par.

First, we extend the notion of 'Sequence' phenomena from tense to person. In Russian, the tense of a direct discourse can be preserved in reported speech, but in English tense agreement, i.e. 'Sequence of Tense', must generally hold. The same contrast exists between English and Amharic pronouns: in Amharic the indexical pronoun of a direct discourse can be retained in reported speech, while in English person agreement, i.e. 'Sequence of Person', must hold. Second, we extend the notion of 'Logophoricity' from person to tense. In Ewe, the indexical pronoun of a direct discourse can only be reported in indirect discourse if a special form is used, one that never occurs outside of attitude environments - a 'logophoric pronoun'. But logophoric tense/mood also exists, and is instantiated by one of the subjunctive forms that exist in modern German (the 'Konjunktiv I'). Third, we observe that both tense and person display the same idiosyncratic behavior in Free Indirect Discourse - an interesting fact given that other indexical elements pattern differently. Finally, we speculate that the notion of Obviation can be extended from person to tense, and suggest that English past tenses are the temporal counterpart of obviative person markers in Algonquian.

Our main auxiliary assumption is that attitude operators are quantifiers over contexts of speech/thought, which allows an indexical expression to be evaluated with respect to the context of a *reported* speech act, and thus to be shifted. Every attitude operator is thus a Kaplanian 'monster', and shifted indexicals are analyzed as a morphological variant of De Se pronouns. Logical forms are assumed to be uniform across languages, with morphology as the only source of cross-linguistic variation.

Acknowledgments

I cannot say how much this work owes to the help of others. For constant discussion and criticism, I wish to thank the members of my committee: Noam Chomsky, Sabine Iatridou, David Pesetsky, Bob Stalnaker, Kai von Stechow, and especially Irene Heim. I have also benefited from discussions with Karlos Arregi, Rajesh Bhatt, David Braun, Sylvain Bromberger, Marie-Hélène Côté, Dave Embick, Danny Fox, Jean-Pierre Gendreau, Martin Hackl, Ken Hale, Morris Halle, Jim Higginbotham, Roumi Izvorski, Ed Keenan, Hilda Koopman, Idan Landau, Pascal Ludwig, Alec Marantz, Ora Matushansky, Jon Nissenbaum, François Récanati, Dominique Sportiche, Tim Stowell, and Arnim von Stechow. Special thanks to Barry Schein for numerous conversations. I presented parts of this work in Berlin (GLOW), Leipzig (Sinn und Bedeutung), Los Angeles (USC and UCLA), Paris (Université de Paris 7), Themi (CHRONOS), and Tübingen – thanks to the audiences for their comments. I owe the native speaker judgments to Cornelia Krause (German), Martin Hackl (Upper Austrian & German), Sabine Iatridou (Greek), Idan Landau (Hebrew), Ora Matushansky (Russian), Lea Nash (Russian), and especially Degif Petros (Amharic & Chaha). The intellectual influence of Francis Wolff and Jean-Claude Pariente was indirect but important – merci. My first two years at MIT were sponsored by École Normale Supérieure and Fondation Thiers.

Immeasurable support was provided by my family: Claire Schlenker & Michel Schlenker, Jean-Marc Schlenker, Martine Schlenker, Evi Schlenker – and Misha Levit. Michel Bar-Zeev, Fränzi Schlenker, Anna Schnaider, and Tamara Levit saw the beginning of my studies at MIT, but not their completion. I dedicate this work to their memory.

TABLE OF CONTENTS

Overview	7
1. Semantic Uniformity	7
2. Empirical basis: cross-categorical generalizations in indirect discourse	8
2.1. Sequence Phenomena	9
2.2. Logophoricity	10
2.3. Free Indirect Discourse	11
3. Auxiliary assumption: attitude operators as quantifiers over contexts	11
4. A second plot: matrix contexts vs. embedded contexts	13
5. Language Variation	15
Chapter 1. Statement of the Cross-Categorical Generalizations	16
I. Generalization 1. Sequence Phenomena Across Domains	16
1.1. Sequence of Tense vs. Non-Sequence of Tense	17
1.2. Sequence-of-Person vs. Non-Sequence-of-Person	21
1.3. Replicating the Distinction within English: Temporal Adverbials	25
1.4. Where we are	28
II. Generalization 2. Logophoricity Across Domains	30
2.1. Author-denoting Logophoric Pronouns	32
2.2. Logophoricity with Tense and Mood	35
III. Generalization 3. Free Indirect Discourse Across Domains	37
IV. Generalization 4. Obviation Across Domains (A Speculation)	39
4.1. Four Definitions of Obviation	39
4.2. Statement of the Hypothesis	40
4.3. Shared properties	43

Chapter 2. A Revised Semantics for Propositional Attitudes	47
I. Problems with a proposition-based system	47
1.1. All-purpose Indexicals	47
1.2. Attitudes De Se	49
II. Proposal	56
2.1. The system: Utterances and Propositional Attitudes	56
2.2. Temporal Adverbials	61
2.3. Comments	65
III. Ross's Generalization and the Performative Analysis	67
3.1. Ross's Generalization	67
3.2. Comparison with Ross's 'Performative Analysis'	70
Appendix I. On Monsters	73
Appendix II. 'He' can be read De Se	75
<i>Guide to the Formal System</i>	84
Chapter 3. Person	88
I. Indexical Pronouns as Bound Variables (English)	89
1.1. 'I' is sometimes a bound variable	89
1.2. 'I' is always a bound variable	92
1.3. Implementation	94
II. Sequence of Person (English vs. Amharic)	95
2.1. English 1st person vs. Amharic 1st person	95
2.2. Agreement and De Se readings	98
2.3. Implementation	104
III. Logophoricity	104
3.1. Author-denoting logophoric pronouns	106
3.2. Hearer-denoting logophoric pronouns	110
IV. Free Indirect Discourse	111
V. Obviation	115
5.1. A Simple Analysis	115
5.2. A Refinement	117

Chapter 4. Present and Past Tenses	120
I. Setting Up the Correspondence between Person and Tense	121
1.1. The General Idea	121
1.2. Propositional Attitudes: Temporal De Re vs. De Se	123
1.3. The Present as a Bound Variable	125
1.4. Past tenses as obviatives (English)	127
II. Sequence of Tense (English vs. Russian)	132
2.1. The Null Hypothesis vs. the History	134
2.2. The Null Hypothesis: Sequence of Tense = Sequence of Person	137
2.3. Summary of the rules	154
III. Logophoric Tense/Mood	155
IV. Free Indirect Discourse	156
Appendix. Future tense and Mood	160
I. Feature transmission under 'will'	160
II. Upper Limit Constraint and Double-Access Readings	163
III. Speculations on Sequence of Mood	169
References	178
Notes	

OVERVIEW

1. Semantic Uniformity

We attempt to establish, within a limited domain, the plausibility of a general hypothesis - that a single interpretive system underlies reference to individuals, to times and to possible worlds; that, in other words, the grammar of person, tense and mood can and should be unified. We call this hypothesis 'Semantic Uniformity'; in its strongest form, it can be stated as follows:

(1) Hypothesis of Semantic Uniformity

Universal Grammar uses the same distinctions (features) and the same interpretive procedures for reference to individuals, times, and possible worlds. Specifically:

- a. Every feature that exists in one domain can (in principle at least) exist in every other domain as well
- b. The interpretive rules for those features are the same across sortal domains¹.

Although the name 'Semantic Uniformity' hasn't been used before, previous work has made this hypothesis plausible in two domains: natural language quantification and anaphora.

Consider quantification first. It was an old insight of intensional logic that the *same* formal system could be used to handle both modality ('can', 'must', etc.) and tense - to handle, in other words, quantification over possible worlds and quantification over times. Originally it was thought that the system that was needed was strictly less powerful than what was required to formalize reference to individuals, i.e. a logic with full quantification over individuals. Interestingly, this hypothesis, which made quantification over times and worlds crucially *different* from quantification over individuals, was in the end disproved. Cresswell 1990 shows that temporal and modal discourse in natural language is rich enough to amount to *full quantification* over times and worlds (an idea first hinted at in van Benthem 1977). In the end, then, it seems that the *same* quantificational system underlies not just reference to times and to worlds, as was originally thought, but also reference to individuals. In that sense Cresswell's work can be seen as an argument for Semantic Uniformity from the study of natural language quantification.

Next, consider anaphora. The notion was originally applied solely to reference to individuals. Partee's discovery (in Partee 1973, further developed, and partly retracted, in Partee 1984) was that it could be extended to reference to time as well. Her argument was that tenses have exactly the same range of uses as pronouns do, and may thus be deictic ('I didn't turn off the stove'), anaphoric or bound. Partee's insights are extended to modality in Stone 1997, where it is claimed that Partee's temporal examples can be replicated with modality. This, in turn, suggests that anaphora applies not just to reference to individuals and to times, but *also* to reference to possible worlds (or scenarios, or whatever one uses to formalize modal discourse). Partee's discovery, together with Stone's extension of it, can thus be seen as an argument for Semantic Uniformity from the study of natural language anaphora².

Other cross-categorical generalizations are also relevant to the Hypothesis of Semantic Uniformity, but will not be discussed for reasons of space. To give one prominent example, it has been argued by Bach that the telic-atelic distinction is the verbal analogue of the count-mass contrast in the nominal domain. The idea is highly appealing from our perspective, but goes beyond the present work. Other attempts at unification in syntax or in semantics are less directly relevant. For the Hypothesis of Semantic Uniformity does not simply claim that different domains should be unified *somehow*. Rather, the suggestion is that a single mapping should yield at the same time a correspondence between the system of morpho-syntactic *features* that are used in different domains, and the *semantic* rules that interpret them. This provides a relatively simple heuristics for determining how the unification should be effected: take the system of features used, say, for reference to individuals; keep the same interpretive rules, but replace symbols ranging over individuals with symbols ranging over times and worlds³ - and you should have obtained the system used by Universal Grammar for reference to times and to worlds. The claim might be too strong, or plainly incorrect, but it is relatively easy to see how it could be fleshed out. Some attempts at unification do not satisfy it. To give but one example, Stowell has suggested in recent years that tenses should be analyzed by analogy with polarity items. His theory provides a simple mapping between the syntax of tense and that of polarity items, but it is not clear what the semantic correspondence should be (i.e. it is not clear that the semantic correspondence would in any way be natural). For an attempt at unification to fall under Semantic Uniformity, it must yield both a morphosyntactic *and* a semantic correspondence.

2. Empirical basis: cross-categorical generalizations in indirect discourse

The general enterprise of arguing for Semantic Uniformity might be exciting, and it might also be wrong-headed; but what seems clear is that it goes far beyond the present work. We thus tackle a problem of more manageable dimensions - we attempt to show that tense, person and mood can be analyzed in uniform fashion *when they occur in indirect discourse*. The restriction is of some interest because a number of non-trivial phenomena occur precisely in these environments. The main line of argument will be as follows:

(i) Three puzzling morpho-semantic phenomena affect person, tense and mood *in indirect discourse and never in other environments*. The facts under consideration are: (1) Sequence effects, (2) Logophoricity, and (3) Free Indirect Discourse.

(ii) Each of these phenomena shows up both with person and with tense/mood⁴, although not necessarily in the same languages.

(iii) Therefore a uniform theory, i.e. a theory that treats in the same way tense, person and mood, should be posited to account for the generalizations.

[We will also mention a fourth possible generalization across sortal domains. We will speculate that the tense system of English has a counterpart in the pronominal system of Algonquian. If this is correct, English tense will turn out to be an 'obviative' system. But since this generalization is not related to indirect discourse *per se*, we do not mention it any further in this Overview].

2.1. Sequence Phenomena

In Russian, the tense of a direct discourse must be retained in reported speech. Thus, if Peter said a week ago: 'It is raining', a Russian speaker has no choice but to report this by saying literally: 'Peter said a week ago that it IS raining'. This is of course impossible in English, where the embedded tense must be shifted so as to agree with the matrix past tense: 'Peter said a week ago that it WAS raining'. Languages like English are said to have a 'Sequence of Tense' rule, which Russian lacks. Our first task is empirical - we have to show that the same typological contrast holds for person (reference to individuals) and mood (reference to possible worlds). The point to establish is that in some languages the tense or mood of a direct discourse must be retained in reported speech, while in others it has to be shifted. The final generalization will look like this:

(2) Sequence Generalization (1)

a. Sequence-of-Tense vs. Non-Sequence-of-Tense

Two weeks ago, Peter said: 'It is raining'

- i) Russian (lit.): Peter said that it IS raining
- ii) English: Peter said that it WAS raining

b. Sequence-of-Person vs. Non-Sequence-of-Person

John says: 'I am a hero'

- i) Amharic (lit.): John_i says that I_i am a hero
- ii) English: John_i says that he_j is a hero

c. Sequence-of-Mood vs. Non-Sequence-of-Mood

- i) M. Greek (lit.): If Mary <was in a situation where she> knew that Clinton IS dead, she would be devastated
- ii) English: If Mary <was in a situation where she> knew that Clinton WAS dead, she would be devastated

As seen in b., just as Russian preserves in reported speech the tense of a direct utterance, Amharic can retain in reported speech the indexical pronoun of a direct utterance, so that 'I' in bi) can refer to John rather than to the actual speaker - an interpretation which is not open to the English speaker. Similarly, in c. if a person's speech or thoughts are reported in a counterfactual proposition in Modern Greek, the mood of the direct discourse can be retained, although this is impossible in English, at least on the intended interpretation [(2ci) is grammatical in English, but has a special reading which the Greek sentence lacks - this will be discussed later].

Tense, indexical pronouns and mood share an interpretive property - their denotation is defined with reference to the speech situation. Thus the present refers to an interval which contains the utterance time; a first person pronoun refers to the speaker; and the use of indicative mood suggests that the proposition expressed holds at worlds that are 'close enough' to the actual world, in a sense to be made precise. All three categories are thus *indexical*⁵. The typological distinctions introduced in (2) can thus be restated more briefly:

(3) Sequence Generalization (2)

- a. Constructions that lack a Sequence 'rule' allow an indexical element to be retained in reported speech in the same form as it would appear in direct discourse.
- b. Constructions that have a Sequence 'rule' do not allow this.

The general idea of relating Sequence of Tense to parallel phenomena in the pronominal domain is not new. In Kratzer 1998, an attempt is made at showing that, within English, there exist locality constraints on certain readings of indexical pronouns which can be replicated in the temporal domain. Apart from the general idea of unifying tense and pronouns, there is very little in common between Kratzer's attempt and ours. In particular, we differ with her on (i) the data we consider (she concentrates on English, while our main argument is that the same cross-linguistic *typologies* are found in each domain), (ii) the theory we put forth, and (iii) the assessment of the data that underlie her own system (see the discussion below)⁶.

2.2. Logophoricity

English present tense and English 'I' can only depend on the context of the actual speech act. The complement set of this class is made of elements that can only depend on the context of a *reported* speech act. In the person domain pronouns that have this property are called 'logophoric'. We suggest that Logophoricity applies across sortal domains.

In Ewe and Gokana, a special pronoun or agreement marker is used whenever a discourse containing a 1st person pronoun is reported in the 3rd person. Thus if Kofi says: 'I am leaving', the English speaker will report this by saying: 'Kofi says that HE is leaving', while the Ewe speaker has to use a special form (call it 'he*') which occurs only in reported speech: 'Kofi says that HE* is leaving'. 'he*' can be used only when it occurs in the scope of an attitude operator - that is, in precisely those environments in which a 1st person pronoun in Amharic can be shifted. There is a difference between the two cases, however: Amharic 'I' can always denote the actual speaker; by contrast, 'he*' can only refer to the author of a *reported* speech act.

But now consider tense/mood. In German there is a special form - call it 'be*' - which appears only in the scope of an attitude operator. If Kofi says: 'Peter is sick', the German speaker can⁷ report this by saying: 'Kofi says that Peter BE* sick'. And, just as 'he*' can never be used in a direct discourse, so similarly 'be*' appears (almost) only when somebody's thoughts or words are reported. To summarize:

(4) Logophoricity Generalization

a. Logophoric pronouns vs. no logophoric pronouns

Situation: Kofi says: 'I am leaving'

- i) Ewe / Gokana: Kofi says that he* is leaving
- ii) English: Kofi says that he is leaving

b. Logophoric tense/mood vs. no logophoric tense/mood

Situation: Kofi says: 'Peter is sick'

- i) German: Kofi says that Peter be* sick
- ii) English: Kofi says that Peter is sick

2.3. Free Indirect Discourse

Finally, consider Free Indirect Discourse, a literary style characterized by the fact that a sentence reports thoughts or words other than the speaker's, even though no attitude operator is present:

- (5) Situation: John said to Ann. 'Yes, indeed, today I want to marry you'
- a. <John was talking to Ann with great passion> Yes, indeed, today he wanted to marry her.
 - b. *<John was talking to Ann with great passion> Yes, indeed, today I wanted to marry you.
 - c. *<John was talking to Ann with great passion> Yes, indeed, today he wants to marry her.
 - d. *John told Ann that <yes, indeed> today he wanted to marry her.

The hallmark of Free Indirect Discourse is that an indexical like 'today' can refer to a moment which is *before* the time of the actual utterance [(5a)], something which is not possible in standard indirect discourse [(5d)]. What is interesting for our purposes is that, by contrast with indexical adverbs like 'today', indexical pronouns and tenses *cannot be shifted* - 'I', 'you' and the present tense can simply not be used, and must be replaced with 'he'/'she' and the past tense. In this case as well, then, we see that *both* pronouns and tense display a puzzling behavior; and that furthermore they seem to display precisely the *same* behavior - again something which is consistent with the Hypothesis of Semantic Uniformity.

3. Auxiliary assumption: attitude operators as quantifiers over contexts

If these generalizations are correct, the point will already be established that any theory of Sequence phenomena must treat reference to individuals, to times and to worlds on a par. But of course we would also like to explain *why* such phenomena should exist in the first place - why Universal Grammar should make these particular options available, and why languages should differ in how they use them. In order to do this, however, we must first make sure that we have the right analytical tools to capture the relevant. This is where we hit trouble, and need an auxiliary assumption.

Consider once again the Sequence Generalization. As was already mentioned it hinges crucially on the notion that an indexical pronoun or tense that appears in direct discourse can be 'retained' in reported speech. But this means that, semantically, an indexical expression can in some cases be evaluated with respect to the context of the *reported* rather than of the actual speech act. This immediately raises a problem. In a standard semantics, an attitude operator is treated as a quantifier over *possible worlds*, so that e.g. 'John believes that Peter is a hero' is analyzed as 'John believes that he lives in a world in which Peter is a hero' [or even less poetically: 'John believes that he lives in

a world w such that Peter is a hero in w]. But on such an analysis there is no mention at all of the context of the reported speech act, with the result that Amharic-style (shifted) indexicals cannot even be formalized.

By contrast, we will argue that attitude operators are in fact quantifiers over *contexts of speech or of thought* - what John believes in our little example is that he is in a thought situation $c = \langle \text{author, time of thought, world of thought} \rangle$ such that 'Peter is a hero' can be uttered or thought truthfully in c . In simple cases the difference between the two theories isn't particularly obvious. But when we come to examples like (2b), the difference will be dramatic. Although on a standard semantics (2bi) cannot be analyzed since an indexical pronoun can only be evaluated with respect to a context of speech/thought, not with respect to a possible world, the problem simply goes away in our framework - the Amharic first person pronoun, just as its English counterpart, is evaluated with respect to a context of utterance (or thought). The only difference between the two is that in Amharic, the first person pronoun can be evaluated with respect to *any* sort of context, while in English it is lexically specified as depending only a coordinate of a context that refers to the actual speaker⁸.

Contexts will play an essential role throughout the analysis. As a first approximation, English-type indexical pronouns and tenses will be treated as *anaphoric to a coordinate of the highest context variable there is*, what we call the 'matrix context variable' - where in normal cases the 'matrix context' has as its value the actual speech situation. By contrast, Amharic-type indexicals will be lexically specified as being bound *either* by a coordinate of the matrix *or* by a coordinate of an embedded context (where 'embedded contexts' are just the context variables that attitude operators quantify over). Logophoric elements are treated as the complement set of English-type indexicals: the latter can be bound only by a coordinate of a *matrix* context; the former can be bound only by a coordinate of an *embedded* context. Finally, Free Indirect Discourse is analyzed as involving a matrix context, and no attitude operator at all; but for reasons to be explained later, in Free Indirect Discourse an element which is semantically dependent on the matrix context is spelled-out as 'he' or as a past tense rather than as 'I', 'you' or as a present tense. If we represent matrix contexts with $\langle X, Y, T, W \rangle$ ($= \langle \text{author, hearer, time, world} \rangle$) and embedded contexts as $\langle x, t, w \rangle$ ($= \langle \text{author, time, world} \rangle$), the system for person vs. tense will look somewhat like this (the lines represent possible relations of binding between a temporal or a pronominal element and a coordinate of a context):

(6)

a. Sequence Phenomena & Logophoricity: Persons

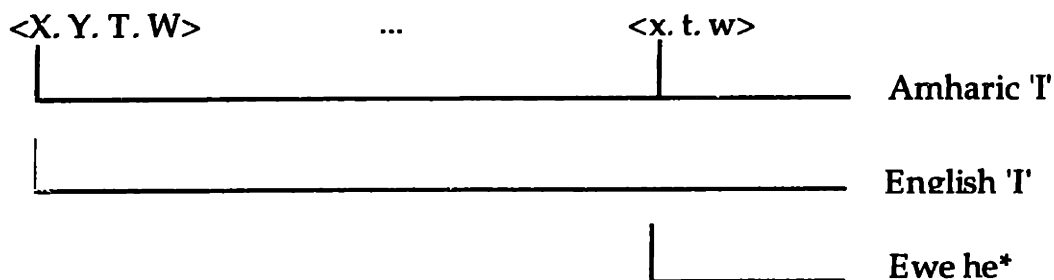

b. Sequence Phenomena & Logophoricity: Tense

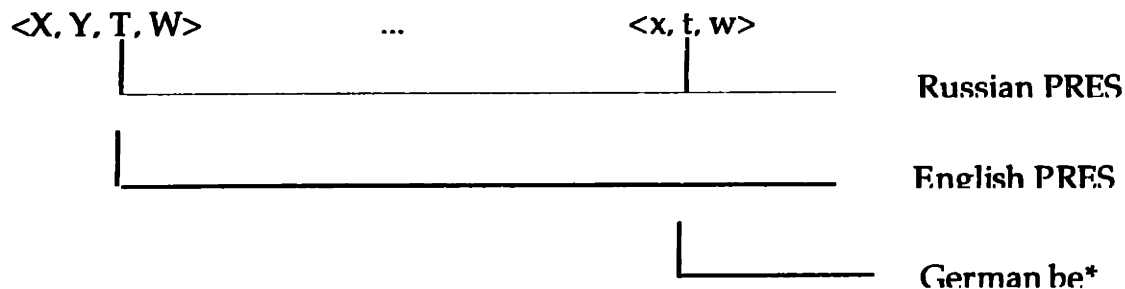

c. Free Indirect Discourse: Person and Tense

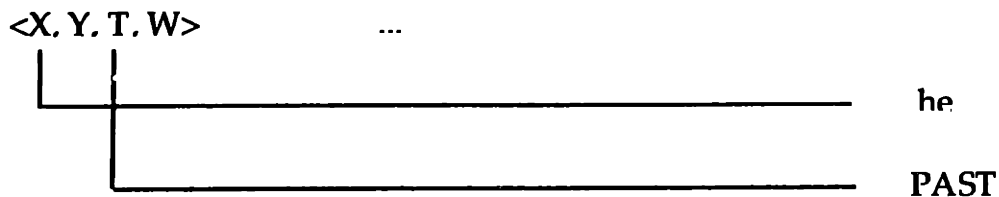

4. A second plot: matrix contexts vs. embedded contexts

So far what is crucial about contexts as we have represented them is that they have coordinates ranging over individuals, times and worlds, and that *all coordinates are treated on a par*. If correct, this provides a direct argument for Semantic Uniformity. But there is another type of generalization that comes out of the theory sketched above: if attitude operators are really quantifiers over *contexts*, elements that are in their scope should in some respects behave like garden-variety indexicals, since they share with indexicals the property of being semantically dependent on a context variable. Thus there should be a natural class that comprises standard indexicals *and* elements that are in the scope of an attitude operator. There are reasons to think that this is indeed correct:

(i) Shifted Indexicals

Morphologically, Amharic 'I' is used both to refer to the author of the actual speech act and to the author of the reported speech act - in fact this was the original motivation for positing that attitude operators are quantifiers over contexts.

(ii) De Se readings

In English, 'he' rather than 'I' is used in an embedded clause to refer to the author of the reported speech act. By contrast, 'I' must be used to refer to the author of the actual speech act. So in English there can be no morphological argument that elements embedded under an attitude operator behave like standard indexicals. But there is *semantic* evidence that they do: there are cases in which 'he' can, and PRO must be *interpreted* exactly as if they were Amharic-style shifted indexicals. In other words, there is interpretive evidence that in some cases 'he' and PRO can be bound by the author coordinate of an embedded context.

Consider the problem of 'De Se' readings. Briefly, the difficulty is that 'John hopes PRO to be elected' does *not* mean (as is assumed within a standard semantics) that John hopes to live in a world *w* in which John is elected. In a somewhat contrived situation, John might be drunk and have forgotten that he is running in the election. And he might be watching a terrific candidate on TV, hoping that *that person* will be elected, without realizing that the candidate in question is John himself. In such a case one cannot claim that 'John hopes PRO to be elected' (though one could say: 'John hopes that he will be elected'). Intuitively, the embedded infinitive only has a reading on which John's hope is of the form: 'I will be elected', not 'He will be elected', even if 'he' refers to John - in other words, it can only have a 'De Se reading', as the phenomenon has been called in the philosophical literature ('he' can have both a De Se and a non-De Se reading). But how are we to represent such readings? In our theory (a modification of Lewis's analysis of Attitudes De Se), the content of John's hope is that he should be in a context in which 'I will be elected' can be uttered truthfully; the non-De Se reading does not satisfy this (since there John's hope is of the form: 'He will be elected'), and the correct distinction can thus be drawn. Thus the De Se problem turns out to be a purely interpretive counterpart of what is overtly expressed in Amharic: De Se 'he' is interpreted as a shifted indexical in English, and it is spelled-out as one in Amharic. The challenge, of course, will be to explain why an element with the semantics of Amharic 'I' should ever be spelled-out as 'he'.

(iii) Ross's generalization

Ross 1970 observed that a number of syntactic rules (in particular, reflexivization in the absence of a local antecedent) apply in exactly the same way to first (and second) person pronouns, and to those third person pronouns that are *embedded under an attitude verb*. The existence of such a natural class is surprising on standard theories, but is expected if attitude operators quantify over contexts. In the present framework Ross' generalization can be stated as a constraint on pronouns bound by the author (and to some extent by the hearer) coordinate of a context, be it matrix or embedded.

5. Language Variation

Before we conclude this overview, we wish to say a word about the role of language variation in this study. The existence of similar cross-linguistic typologies in the domain of reference to individuals, times and worlds is an important argument for Semantic Uniformity. But why should there be any differences across languages in the first place? The strategy pursued here is to suggest that with respect to the phenomena under study *there is no cross-linguistic variation in the syntax or in the semantics*. The only cross-linguistic difference there is has to do with the lexical items that are available to spell-out bundles of syntactic features. In other words, we pursue in this study a Null Theory of linguistic variation: all languages are identical, except in the way they pronounce feature bundles.

The thesis is organized as follows. We first lay out the cross-categorical generalizations (chapter 1), and then develop a modified semantics for attitudes in order to handle shifted indexicals of the Amharic type (chapter 2). We then give a detailed account of pronouns (chapter 3), which we then extend to present and past tenses (chapter 4) and finally to future tense and mood (Appendix).

CHAPTER 1. STATEMENT OF THE CROSS-CATEGORIAL GENERALIZATIONS

The goal of this chapter is to give a precise statement of the cross-categorical generalizations which provide the empirical basis for the Hypothesis of Semantic Uniformity.

(i) First, we show that the contrast between Sequence-of-Tense and Non-Sequence-of-Tense languages can be replicated in other sortal domains. We thus display Sequence-of-Person and Sequence-of-Mood effects.

(ii) Second, we suggest that logophoric pronouns/agreement markers in Ewe and Gokana have a counterpart in the tense/mood domain: the 'Konjunktiv I' in German can be analyzed as a logophoric tense/mood.

(iii) Third, we show that person and tense display the same puzzling behavior in Free Indirect Discourse, a behavior which other indexical elements (for example temporal adverbials) do not have.

(iv) Finally we suggest, somewhat more tentatively, that there are parallels between person and tense even outside the domain of indexical elements: the past tenses of English (past tense and pluperfect) can be analyzed as the counterpart of the obviative systems that are found in Algonquian in the person domain.

I. GENERALIZATION 1. SEQUENCE PHENOMENA ACROSS DOMAINS

Let us first dispel a possible confusion. The term 'non Sequence of Tense language' (non SOT) has been applied to two very distinct types of languages <REF TO KONDRASHOVA>. On the one hand Russian or Hebrew are said to be 'non SOT'. Both of them preserve in reported speech the tense of a direct discourse ('reported speech' should be understood as including reports of thought as well as of speech - as we use it, the term can be used whenever a propositional attitude is described). They differ in this respect from English or French, which cannot normally do this when the matrix verb is in the past tense. Outside of attitude environments (in particular, in relative clauses), Russian and Hebrew pattern exactly like English. However the term 'non SOT' is also applied to Japanese [Ogihara 1996]. Japanese does indeed follow the pattern of Russian or Hebrew in reported speech - it preserves in the embedded clause the tense of the original discourse. In addition, however, Japanese *also* differs from English and Russian *outside* of attitude contexts, so that a present tense which appears in a relative clause may be interpreted as referring to a past moment *if the matrix verb is itself in the past tense*. The typological situation is summarized in the following table (from Kusumoto 1998; she in turn cites Kondrashova):

- (1) a. Attitude environments: John said a week ago: 'Pjeita is crying'
 b. Relative clauses: John met a week ago a man who was crying

	English	Russian	Japanese
Attitude	Past	Present	Present
Relative	Past	Past	Present

We will be exclusively concerned with the contrast between English and Russian, and will have nothing to say about Japanese. Whenever we use the term 'non Sequence of Tense', it should be understood as 'non Sequence of Tense in the Russian sense'. Obviously one wants in the end to have a theory that also accounts for Japanese, but this is an enterprise that goes beyond the present work.

1.1. Sequence of Tense vs. Non-Sequence of Tense

a) Basic facts

The essential contrasts are presented below:

- (2) a. (A week ago) Pjetja said that Misha was crying (*is crying)
 b. (A week ago) Pjetja met a person who was crying
- (3) a. Pjetja_i skazal, Cto miSa plaCet [Russian]
Pjetja_i said that Misha is-crying
 'Pjetja said that Misha was crying [at the time of Pjetja's utterance]'
- a'. Pjetja_i skazal, Cto oni plaCet [Russian]
Pjetja_i said that he_j is-crying
 'Pjetja said that he was crying [at the time of his utterance]'
- b. Pjetja vstretil Celoveka, kotory plaCet [Russian]
Pjetja met person, who is-crying
 'Pjetja met a person who is crying / cries'

NOT: 'Pjetja met a person who was crying [at the time of the meeting]'

[Similar examples in Kondrashova 1999. See also Kusumoto 1998]

With respect to relative clauses, Russian and English pattern on a par - a present tense can only be interpreted as referring to the Utterance time. In attitude contexts, however, things are different - if Pjetja said a week ago: 'Misha is crying', there is no way to report this in English but by using a past tense in the embedded clause. Russian, on the other hand, preserves in the embedded clause the present tense of the direct discourse.

Let us now characterize the contrast between the two languages. The generalization can be stated as follows:

- (4) a. The difference between English and Russian occurs only when a verb is interpreted in the scope of an attitude operator.
 b. In Russian the tense of a direct discourse is preserved in reported speech. In English the tense of a direct discourse is not preserved if the matrix verb in the past tense; in these cases the embedded verb must bear past tense morphology.

[...] If we want to describe this situation now, we cannot say:

(7) John married a woman who might become rich. [Abusch's (40)]¹⁰

(Note that unlike 'might', 'could' would be perfect in (7): 'John married a woman who at the time could - and later did - become rich'). By contrast, Abusch observes that the modal of the direct discourse can be preserved in reported speech:

(8) John believed that his bride might become rich [Abusch's (42b)]¹¹

Thus 'might' has exactly the distribution of a Russian present tense verb: (a) it *cannot* be used with a shifted reading in a relative clause, but (b) it *can* be shifted when it appears in an attitude environment. These properties follow if we assume that 'might' has no past tense, and has exactly the same lexical specifications as a present tense verb in Russian. These examples will provide an argument that no language-particular rule should be postulated, since within English a subclass of verbs (some of the modals) behave exactly like present tense does in Russian quite generally. For the moment, however, the important point is that the generalization must be stated in terms of attitude contexts¹².

The result, then, is that the contrast between Russian and English (or between English verbs and English modals) arises just in case an embedded tense is in the scope of an attitude operator.

c) Indexicality

We now come to the second part of the generalization. The difference between English and Russian can be characterized in the following terms: an indexical tense is always preserved in reported speech in Russian, but not in English. For future reference, we attempt to draw several empirical and terminological distinctions which will be necessary for a more precise understanding of indexicality.

An element is indexical if its denotation depends on the context of speech¹³. By 'context of speech' we understand the information that characterizes the speech event in a narrow sense: who the speaker and hearer are, and what the time and world of utterance are. Contexts of speech (or simply 'contexts') will be represented in what follows as tuples of the form $\langle X, Y, T, W \rangle$, where X is the speaker (or 'author') of the speech event, Y is the hearer, T the time of utterance, and W the world of utterance. Thus for example $\langle \text{John, Mary, 5:00 pm, } W^* \rangle$ is the context of a speech event that occurred at 5:00 pm in the actual world W^* , with John as the speaker and Mary as the hearer. This very narrow notion of context should be kept clearly distinct from the 'discourse context', i.e. the set of presuppositions shared by the speaker and the hearer of a speech act. The latter notion is for instance relevant when the denotation of a definite description must be computed ('the President' typically refers to Clinton if the speaker and hearer are American, but to Chirac if they are French); but it will *not* be relevant in what follows: when we speak of a 'context', we will always have in mind the context of speech in the narrow sense, i.e. a tuple of the form $\langle \text{author, hearer, time of utterance, world of utterance} \rangle$.

We henceforth use the word 'indexicality' exclusively to refer to context-dependency *in the narrow sense*. But we will need additional distinctions as well. We will say that an element has *indexical uses* if its denotation depends a coordinate of the

context of speech. Thus 'today' uttered on Monday does not refer to same day as if its uttered on Tuesday; clearly, then, the word can be used indexically. An easy truth-conditional test to determine whether an expression is indexical is to change the context of speech, and see whether the reference of the expression changes¹⁴.

But besides *indexical uses* of an element, we also wish to define a class of elements which are *lexically specified as indexical*, or in other words which can only depend on a coordinate of a context, and never on any other elements. To see why this additional distinction is needed, consider the following cases:

- (9) a. John will come tomorrow
b. John will come two days later
- (10) a. *A week ago Mary criticized a man who killed himself tomorrow.
b. A week ago Mary criticized a man who killed himself later.

Both 'the day after tomorrow' and 'two days later' count as indexical according to the truth-conditional test - both (9a) and (9b) might for instance be true if uttered on Monday, but not on Tuesday. Still, there is an important difference between 'later' and 'tomorrow', which is brought out in (10). Although the context of speech is the same in both cases, 'later' can, but 'tomorrow' cannot be used in this situation. For 'tomorrow', the reason seems obvious enough - the term must refer to a moment that *follows* the speech time, which contradicts the use of the past tense in the relative clause. But then why is 'later' perfect in that environment? A natural assumption is that 'later' is in fact *anaphoric* to the tense of the matrix clause, and has a representation of the form 'later than it', with ellipsis of the pronominal argument of the comparative¹⁵. Being anaphoric, its concealed argument 'it' may be coindexed with the time coordinate of the context of speech, as in (9b), or it may corefer with any salient moment introduced in the previous discourse.

We will thus distinguish between:

- (i) elements that are *lexically specified as indexical*, i.e. which can *only* depend on a coordinate of a context, and
- (ii) elements that are *anaphoric*, and may be coindexed with any salient element of a discourse (one of these being, in some cases, a coordinate of a context).

'tomorrow' satisfies (i), while 'later ~~than it~~' falls under (ii). If we wish to single out a class of items that are lexically as indexical, we must thus add an additional criterion:

(11) Distributional criterion

An element is *lexically specified as indexical* if it can only be evaluated with respect to some coordinate of a context.

According to the distributional criterion, 'tomorrow' is indexical, while 'later' is not, and should count as anaphoric.

1.2. Sequence-of-Person vs. Non-Sequence-of-Person

We now show that the contrast between English and Russian tense can be replicated in the person domain. Just as Russian preserves in reported speech the tense of a direct discourse, so Amharic preserves in reported speech the 1st or 2nd person pronoun of a direct discourse:

(12) <Situation: John says: 'I am a hero'> [D. Petros, p.c.]

john Jägna näNN yt-lall
 John hero I-am says-3 sg.m
 'John says that he is a hero'

Typically one reacts to such examples by claiming that the embedded clause must be quoted. This is a possible explanation for this simple example, but it won't do in the general case in Amharic, and, in fact, in many other languages as well. We now show why this is so.

a) The embedded clause is not quoted

Consider the following examples, which involve embedded questions in Amharic and Chaha, a closely-related Semitic language of Ethiopia. The point of interest is the use of a 2nd person pronoun in the embedded clause:

(13) a. mðn amTa ðndaläNN alsämmahumm
 [[what bring-imp.2sg] that-he-said-to-me] I-didn't-hear
 'I didn't hear what he told me to bring' [Amharic, Leslau 1995 + Petros]

b. mIr namð yð-bar-e xðma an-sðma-x^W
 [[what bring-imp.-2sg] yð.say.to-me that] neg.listen.I
 'I didn't hear what he told me to bring' [Chaha, D. Petros, p.c.]

a. means literally 'I didn't hear that he said to me bring [imperative] what'. Now in this case it is clear that the embedded clause could not possibly be quoted - 'Bring what!' just doesn't make sense! The translation of the sentence tells us what the intended reading is - 'I didn't hear what he told me to bring', i.e. he told me 'Bring X!', and I didn't hear what the X was. More precisely, the argument that we are dealing here with indirect rather than with direct discourse runs as follows:

(i) **Hypothesis:** Quotations can never be affected by grammatical processes. In particular overt or covert extraction out of a quotation is impossible.

Thus in English or in French wh-extraction out of a quoted sentence is always impossible, even when the wh-word remains in situ:

- (14)a. What did John say he liked t?
 b. *John said he liked what? [Ok in an echo question]
 a'. *What did John say: 'I like t'?
 b'. *John said: 'I like' what?

- (15) a. *Qu'est-ce que Jean a dit qu' il aimait?*
What is-it that Jean has said that he liked?
 b. *Jean a dit qu' il aimait quoi?*
Jean has said that he liked what?
 a'. **Qu'est-ce que Jean a dit: 'j'aime'?*
What is it that Jean has said: 'I like'?
 b'. **Jean a dit: 'j'aime' quoi?*
Jean has said: 'I like' what?

(ii) **Observation:** In our Amharic and Chaha examples a wh-word is extracted out of the embedded clause¹⁶.

(iii) **Conclusion:** In these examples the embedded clause is not quoted.

One could challenge the hypothesis and suggest that the difference between Amharic or Chaha and English is that the former allow extraction out of a quoted sentence (alternatively the hypothesis could be that partial quotation is possible in Amharic and Chaha, though not in English; under this view only the embedded verb would be quoted, while the embedded object would not be, allowing wh-extraction to take place). Preliminary (and somewhat tentative) evidence suggests that this is not correct, however:

(16) a. **Situation:** John and Peter each said: 'I am a hero'

b. **Report:** John-Inna Peter [Jəgna nən] alu [D. Petros, p.c.]
John and Peter [hero we-are] they-said

'John and Peter said that they were heroes'

No plural element was used in the sentences uttered by John and Peter (each of them was only talking about himself). Still, the copula that appears in the embedded clause in b. bears 1st person *and* plural features. But this means that the word 'nən' ('we-are') could not be quoted in this case. Thus even if we were to relax the conditions on quotation in Chaha and Amharic, our problem would still remain unsolved.¹⁷

[A technical notion of quotation could be devised that allowed a single syntactic feature rather than an entire sentence or a word to be quoted. But this would be a different enterprise altogether].

It should be noted at this point that the embedded indexical pronoun can but does not *have* to be interpreted with respect to the reported speech act. It could also refer to the actual speaker, and in many cases this leads to multiple ambiguities:

(17) **Situation:** John said: 'I like X', but Mary (she) didn't hear what the X was

mən əwədalläx^w əndaläalsämacəm
what I-like that-he-said she-didn't-hear

'She didn't hear what he_j said he_j liked' [Amharic, D. Petros, p. c.]

or 'She didn't hear what he said I liked'

Similar facts are reported for a number of languages, e.g. for Navajo in Hale & Platero 1998 and Speas 1999, etc.

The logic of our discussion can and will be applied to other constructions as well. Each time the argument will take the same form:

- One element of the embedded clause shows that indirect rather than direct discourse is used
- Still, an indexical can be interpreted with respect to the context of the *reported* speech act.

We now sketch other versions of the argument, for Amharic and for other languages:

(i) Two 1st-person pronouns in the same embedded clause with different referents

- (18) a. aləttazzäNN alä [Amharic, Leslau 1995, p. 779]
I-will-not-obey-me he-said
'He refused to obey me'
- b. alaggəzäNN aläCC
I-will-not-help-me she-said
'She refused to help me'

In (18) what tells us that the embedded clause is not cited is that one of the indexical pronouns is interpreted with respect to the context of the actual speech act - thus in a. the object first person pronoun refers to the actual speaker, not to the speaker of the reported speech act. However these sentences also contain another indexical pronoun which is interpreted with respect to the context of the reported speech act - thus the subject pronoun of the embedded clause in a. does not refer to the actual speaker, but to the speaker of the reported speech act. In all of these cases it is clear that the embedded sentence is not quoted, since it would not make sense in a direct discourse (for instance a. would have to be literally: 'I will not obey me', which is certainly not the intended reading).

(ii) 'Semi-indirect' quotation in Engenni and in Aghem

Researchers that have described languages like Amharic have often been puzzled by these indexicals which can be interpreted with respect to the context of the embedded speech act. Some have come up with the descriptive category of 'semi-indirect' quotation to characterize these surprising examples, which have properties of both direct and indirect discourse.

-Engenni [Kwa; Thomas 1978]

In Engenni, a Kwa language described by Elaine Thomas, the indexical that displays a surprising behavior is the second person pronoun, which in reported speech

can refer to the hearer of the *reported* speech act. The first person pronoun, on the other hand, has the behavior of its English counterpart. This minimal difference suggests that what is at stake is *not* a rule active for a language as a whole, since this would lead one to expect that all indexical pronouns should behave on a par, contrary to fact.

(19)	Speaker of reported speech-act	Hearer of reported speech-act
Direct	1st	2nd
Indirect	3rd reflexive	3rd
'Semi-indirect'	3rd	2nd

(20) a.ò wei ga ... bhú tou èi ka òkì nàà iwó wu zà
 he say [sp you should-take him seq he and you should-die stay]
 2-sub 3(-ref)-obj 3-ref-sub 2-obj

'He said, "Look after me, and I will die with you"' or
 'He said that she should look after him, and he would die with her'

b. ... ga òkí wo ku wo <ga bhù nà gba> à
 sp he not-say give you <that you neg tell >
 3-ref-sub 2-obj 2-sub

'(He said,) "Did I not tell you that you weren't to tell anyone?"' or
 '(He said) hadn't he told him that he wasn't to tell anyone?'

Similar phenomena were described by Hyman for Aghem:

-Aghem [Bantu; Hyman 1979]

(21) wizín 'vÚ ndzÈ à wín Ní'á é Ngé 'lghá wò
 [woman that] said to him [that LOG-3 much like you]

'the woman said to him that she liked him a lot', or
 'the woman said to him "I like you"'

Here the use of the 3rd person logophoric pronoun shows that the embedded clause is not quoted; but still a second person pronoun can be used to refer to the hearer of the reported speech act.

The conclusion, then, is that there are numerous cases cross-linguistically where an indexical is evaluated with respect to the context of a reported speech act, even though the embedded clause is not quoted. This is of course reminiscent of the Russian facts as we analyzed them. We now show that the parallel is complete.

b) Propositional Attitudes

Just as with Russian tense, it is only in attitude contexts that an indexical pronoun can be evaluated with something else than the context of the actual speech act. Thus there is no contrast between English and Amharic with respect to relative clauses:

(22) a. [My_k brother]_i found a girl that he_i, *_k likes

b. [My_k brother]_i found a girl that I_{*i}, _k like

a'. wəndIme yəmmiwədatIn IJ agəNNə
[my_k-brother]_i whom-he_i, *_k-likes girl found
'My brother found a girl he likes'

b'. wəndIme yəmmIwədatIn IJ agəNNə
[my_k-brother]_i whom-I_{*i}, _k-like girl found
'My brother found a girl I like'

c) Indexicality

Finally, using our truth-conditional test it is fairly obvious that the Amharic 1st person pronoun is an indexical. Furthermore, it also appears to be lexically specified as indexical according to our distributional test - as shown above in a relative clause the 1st person pronoun cannot be used unless it refers to the speaker. The generalization appears to be that in Amharic an 1st person indexical pronoun is preserved in indirect discourse. In English, however, this is impossible - there is an important difference between the following examples (Carnap, p.c. to Kaplan):

- (23) a. Otto said "I am a fool"
b. Otto said that I am a fool

In order to report the claim in a., one has no choice but to say:

(24) Otto said that he was a fool

Thus, while Amharic can retain in reported speech the 1st person pronoun of a direct discourse, this option is not open in English, and an anaphoric pronoun must be used instead. And, just as English embedded tense had to agree with the tense of the matrix clause, so similarly the embedded pronoun has to agree with the agent of the matrix attitude verb:

- (25) a. I said that I was a fool
b. You said that you were a fool
c. She said that she was a fool

1.3. Replicating the Distinction within English: Temporal Adverbials

A generalization across sortal domains now suggests itself - some indexicals (Russian tense, Amharic 1st person pronoun) can be retained in reported speech, while others (English tense, English 'I') cannot; in the latter case an anaphoric device must be used instead. We now show that these cross-linguistic distinctions can be replicated within English, although in a different domain. Consider the following temporal PPs:

(26) Situation: John has told me repeatedly over the years: 'I'll give you your money back in two days / the day after tomorrow'

a. John has told me repeatedly over the years that he would give me my money back in two days.

b. *John has told me repeatedly over the years that he would give me my money back the day after tomorrow.

c. John has told me repeatedly over the years that he would give my money back two days later.

In the situation described above, a sentence uttered in direct discourse involves an indexical - e.g. 'in two days' or 'the day after tomorrow' (it doesn't matter which). It can be checked that these are indeed indexical expressions:

(i) Semantically, it is clear that 'in two days' or 'the day after tomorrow' do not refer to the same day when they are uttered on Monday or on Tuesday.

(ii) Furthermore, these expressions are not anaphoric - they cannot be evaluated with respect to just any element made salient in a discourse. For instance, when they occur in a relative clause or in an independent clause they can only be evaluated with respect to the time of the actual utterance. In this respect they differ minimally from 'two days later', as shown below:

(27) a. *I met John a week ago. In two days he gave me my money back.
b. *I met John a week ago. The day after tomorrow he gave me my money back.

c. I met John a week ago. Two days later he gave me my money back

(28) a. *A week ago I met a man who left in two days [Ok if 'in two days' is interpreted as 'within two days', but * if it means: exactly two days later]

b. *A week ago I met a man who left the day after tomorrow

c. A week ago I met a man who left two days later

But although 'in two days' and 'the day after tomorrow' are both indexical expressions, there is a minimal difference between them - while 'the day after tomorrow' can only be evaluated with respect to the time of the actual utterance, 'in two days' may either be evaluated *either* with respect to the time of the actual *or* with respect to the time of the reported utterance. Furthermore, just like the distinction between English and Russian tense, or English and Amharic pronouns, the difference between 'in two days' and 'the day after tomorrow' shows up only in attitude contexts. It fails to hold in complements of causatives:

(29) a. *? A week ago John made Peter leave in two days. [Ok if 'in two days' is interpreted as 'within two days', but * if it means: exactly two days later]

b. *A week ago John made Peter leave the day after tomorrow.

c. A week ago John made Peter leave two days later.

What we see, then, is that we can replicate within English the distinction between English and Russian tense, or English and Amharic first (and second) person pronouns. Like Russian tense and like the Amharic first person pronoun, 'in two days' is an indexical expression which can be evaluated either with respect to the actual utterance or with respect to the context of the reported speech act. 'The day after tomorrow', by contrast, behaves like the English present tense or 'T': it can only be evaluated with respect to the context of the actual utterance. *Indexical devices which can be evaluated with*

respect to any context (actual or reported) will henceforth be called 'all-purpose indexicals'. Indexicals which can only be evaluated with respect to the context of the actual speech act will be called 'matrix indexicals' [note that a matrix indexical depends, not on any element of the matrix clause, but only on the context of the matrix clause; this will be formalized below, where the term 'matrix' indexical will be further justified]. The results of our typological investigations can now be summarized as follows:

(30)

	Indexical devices	
	All-purpose	Matrix
Adverbs	in two days	the day after tomorrow
Pronouns	Amharic 'I'	English 'I'
Tense	Russian present tense	English present tense

But this table is still incomplete. As was shown in the c. examples above, yet another device can be used in indirect discourse to report what would be in direct discourse an indexical like 'in two days' or 'the day after tomorrow', as in a. below:

- (31) a. John has told me repeatedly over the years that he would give me my money back **two days later**
 b. *John has told me repeatedly over the years: 'I'll give you your money back **two days later**'
 c. I met John a week ago. **Two days later** he gave me my money back.

What is the nature of 'two days later'? First, we observe (as in b.) that it cannot be used in direct speech with the meaning of the indexical 'the day after tomorrow' (or 'in two days'); rather, it requires an antecedent made salient in the previous discourse or in the speech situation¹⁸, and when there is one, it can be evaluated with respect to any moment made salient in a previous discourse, as in c. above. This strongly suggests that 'two days later' is anaphoric rather than indexical, and as we saw above in the case of 'later', this fits well with the syntactic nature of the expression: 'later' being a comparative, it is natural to assume that it has a concealed pronominal argument ['two days later ~~than it~~¹⁹].

Strikingly, this is a pattern that we already observed in the pronominal domain - in fact this is exactly the device that English uses to report in indirect discourse what would be a first or a second person pronoun if the utterance were quoted. Thus if John says: 'I am a hero', the report will read: 'John says that HE is a hero', where 'he' agrees in features with the matrix subject 'John'. Now on the face of it 'he' here is just what it normally is, an anaphoric device. The only difference between 'two days later' and 'he' is that the pronoun is concealed in the first case, and overt in the second.

Let us now go one step further. What happens in English when the present tense of a direct discourse is reported with a past tense in an embedded clause? John said a year ago: 'Mary is pregnant'. If we report this today, we have to say that 'John said a year ago that Mary **WAS** pregnant'. By analogy with 'two days later ~~than it~~' and with 'he', we wish to suggest that 'was' in sequence-of-tense environments is a *temporal pronoun that agrees in features with the matrix past tense*. The hypothesis is that this is but

one more case of a past tense used anaphorically, as in Partee's examples (Partee 1973, 1984):

(32) Sheila had a party last Friday and Sam got drunk [Partee 1973, ex. (10), p. 605]

We thus end up with the following typology:

(33)

	Indexical devices		Anaphoric Devices
	All-purpose	Matrix	
Adverbs	in two days	the day after tomorrow	two days later than it;
Pronouns	Amharic 'I'	English 'I'	English 'he'
Tense	Russian present tense	English present tense	English past tense [in SOT contexts]

Treating 'was' as a result of agreement when it occurs in Sequence of Tense environments has an important advantage - it will allow the tense features to remain uninterpreted (along lines to be developed below). This is important because it is known that in SOT environments a past tense does not (even in English) always 'refer' to a moment that precedes the time of utterance. This was the point of the following type of examples, first brought up by Kamp & Rohrer:

(34) Yesterday John decided that tomorrow at lunch time he would tell his mother that they WERE having their last meal together.

Since in this sentence the time of the meal is supposed to be 'tomorrow', the most deeply embedded tense refers to a moment which does not precede *any* moment introduced in the previous discourse, and in particular not the Utterance time. This will be accounted for by positing that, in case the tense features are the result of agreement, they simply remain uninterpreted.

1.4. Where we are

The result of these typological investigations is the following:

(i) Sequence phenomena exist not just in the temporal domain, but also in the person domain (we leave for chapter 5 the discussion of Sequence of Mood)

(ii) The contrast between English 'I', Amharic 'I', and English 'he', or that between the English present, the Russian present and the English past tense when it occurs in an SOT environment, can be replicated within English with temporal adverbials.

Anticipating on the theory to be developed below, we can summarize our results so far in the following way (as before, $\langle X, Y, T, W \rangle = \langle \text{author, hearer, time, world} \rangle$ is the matrix context, while $\langle x, t, w \rangle = \langle \text{author, time, world} \rangle$ is the embedded context variable which the attitude operator quantifies over):

(34) Summary

a. Person

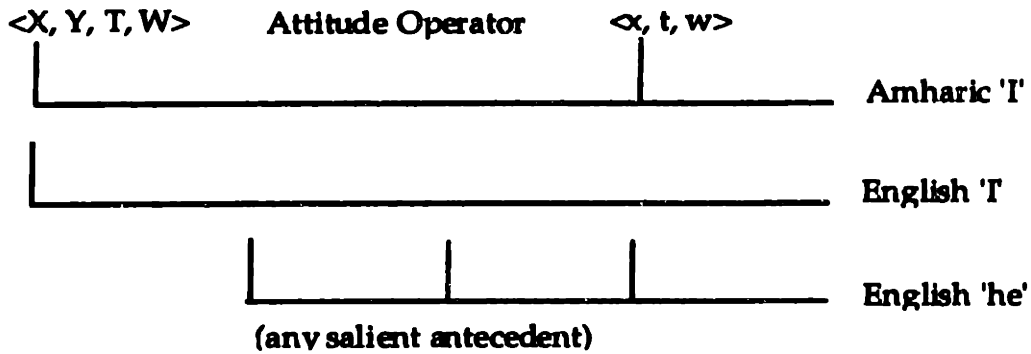

b. Tense

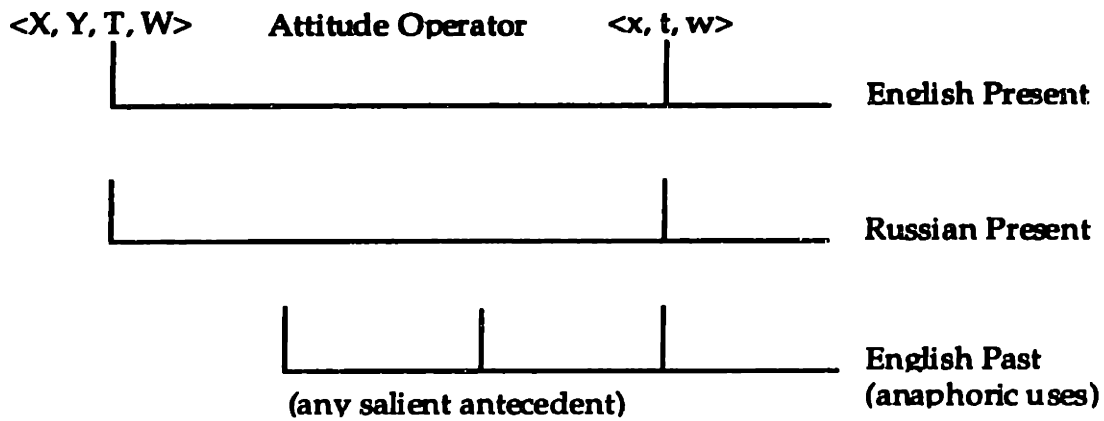

c. Temporal Adverbials

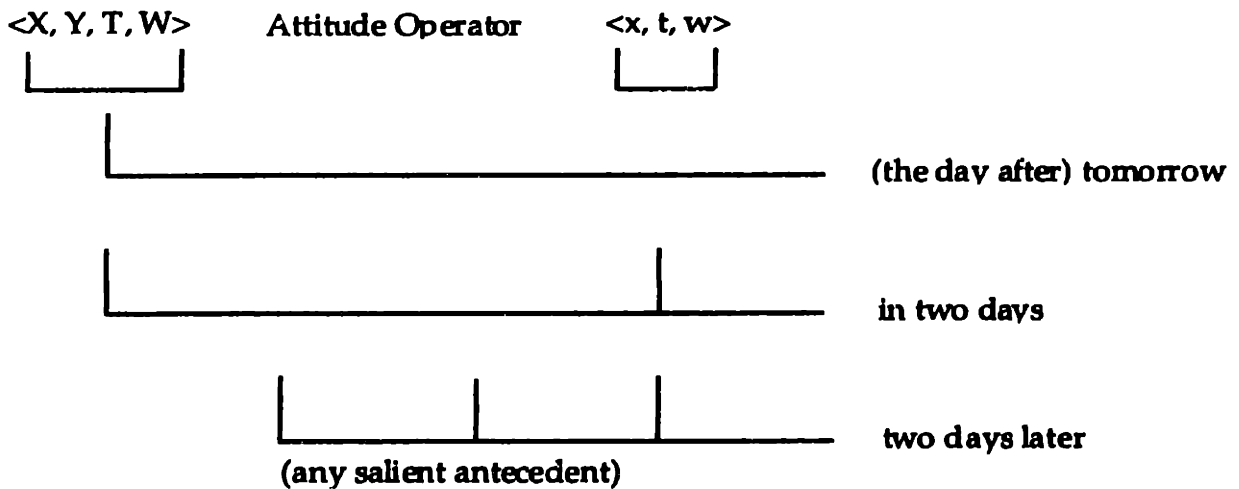

[For reasons that will become apparent in Chapters 2 and 3, we do not indicate a direct dependency between 'in two days' / '(the day after) tomorrow' and the time coordinate of a context; rather, we show a dependency between these elements and a context as a whole. Nothing hinges on this at this point, since a time coordinate *t* is trivially recoverable from a context $\langle x, (y), t, w \rangle$]

In a sense one might wonder whether the generalizations we have obtained are not too much of a good thing. We wanted to show that tense and person behave in a uniform fashion. But we have now shown more: whatever typology is found in each of these domains can be replicated with English temporal adverbials. This, in turn, suggests that Sequence phenomena might have nothing to do with tense or person *per se*; rather, they seem to be a by-product of certain lexical specifications which make an item either 'matrix indexical' (= 'tomorrow'), 'all-purpose indexical' (= 'in two days'), or anaphoric (= 'two days later'). This result would of course be *consistent* with the Hypothesis of Semantic Uniformity, for it would suggest that no domain-specific stipulations are needed to handle Sequence phenomena. But it might also prove too much - an ideal argument for Semantic Uniformity would be that a certain quirk exists, say, in the temporal domain, and that exactly the *same* quirk exists in the person domain as well. However at this point there appears to be no quirk at all, just some general properties of indexicality and anaphora.

But temporal and pronominal quirks do exist. The rest of this chapters discusses three of them, which appear to exist in the pronominal, in the temporal and maybe in the modal domain, *but nowhere else*. They will thus strengthen the general argument for Semantic Uniformity.

II. GENERALIZATION 2. LOGOPHORICITY ACROSS DOMAINS

Logophoric pronouns (etymologically: pronouns that 'carry discourse' - the terminology seems to be due to Hagege 1974) are anaphoric elements that can only appear in reported speech²⁰. Specifically, the logophoric pronoun in Ewe (beautifully described in Clements 1975) can only be used to refer to the author of a *reported* speech or thought act; we call it 'he*-1'. [We will see in Chapter 3 that there also exist in Mapun logophoric elements which are used primarily to refer to the *hearer* of a reported speech act; we will call these elements 'he*-2']. But here is now the remarkable fact: logophoric pronouns have a counterpart in the tense/mood domain. The 'Konjunktiv I', one of the two subjunctives found in modern German, can (almost) only be used in reported speech, and always refers to the time/world of the reported speech act. The suggestion, then, is that the Konjunktiv I is a logophoric tense or a logophoric mood (we leave it for future research to determine which one it is). Furthermore, there do not appear to be adverbial counterparts to logophoric pronouns or logophoric tense/mood; logophoricity appears to be a phenomenon found exclusively in the tense/person/mood domain (although in fairness it must be said that too little is known concerning the phenomenon to make any strong claims about which cases are or are not instantiated).

The idea that tenses may behave as logophoric pronoun has been explored in Kusumoto 1998. Kusumoto suggests that bound uses of the present tense in Russian and Japanese should be compared respectively to the logophoric pronoun 'ye' in Ewe and to the long-distance reflexive 'zibun' in Japanese. Her analogies are highly suggestive, and the data she considers are clearly relevant for the Hypothesis of Semantic Uniformity. However the terminology is slightly deceptive: while 'zibun' might have logophoric uses, it is *not* a logophoric pronoun in the strict sense, since it can be used outside the scope of an attitude operator (e.g. in a relative clause). And while the Russian present can be shifted *only* when it is in the scope of an attitude operator, it can obviously appear in matrix sentences as well (this also applies to the Japanese present, which in addition can be shifted when it appears in a relative clause). It is however the case, as we will see in Chapter 4, that a shifted present in Russian can be analyzed exactly like an Ewe logophoric pronoun, at least if one accepts to posit homophonous lexical entries (since we must *also* account for the non-logophoric uses of the Russian morpheme). Kusumoto's insight was thus correct.

In the notation we have been using so far, the crucial facts we consider can be summarized as follows [for future reference we include in this summary hearer-denoting logophoric pronouns; but since they do not bear directly on the issue of cross-categorial generalizations, we leave the discussion of the relevant facts for Chapter 3] :

(35) Logophoricity

a. Author-denoting logophoric pronouns

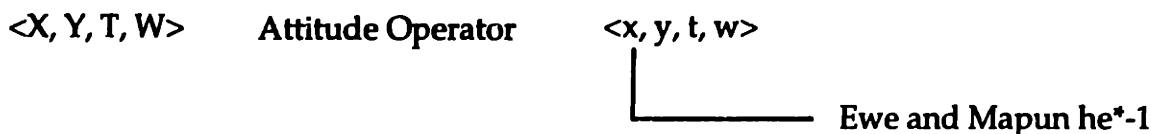

b. Hearer-denoting logophoric pronouns



c. Logophoric tense/mood

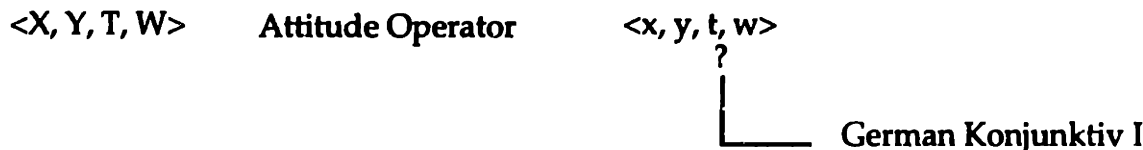

2.1. Author-denoting Logophoric Pronouns

We consider two cases of author-denoting logophoric pronouns. One is Ewe 'yè', described in great detail in Clements 1975; the other is the logophoric agreement marker which can appear on the verb in Gokana, as described in Hyman & Comrie 1981. The major difference between the two cases (at least for our purposes) is that Ewe 'yè' can only appear when the matrix element it 'corefers' with is in the 2nd or in 3rd person, while in Gokana all three persons can take the logophoric agreement marker (however the logophoric marker appears to be dispreferred in the 1st person, for reasons which I do not understand).

Here are the major properties of Ewe and Gokana logophors:

(i) Logophoric elements appear only in attitude environments

First, the elements under study can only appear in attitude environments, and never in other embedded contexts:

- Logophoric elements can occur when embedded under an attitude verb:

(36) Ewe: basic examples

a. kofi be yè-dzo [=Clements's (1)]
Kofi say LOG-leave
 'Kofi said that he (Kofi) left'

b. kofi be e-dzo [=Clements's (3)]
Kofi say he/she left
 'Kofi said that he/she (≠Kofi) left'

(36') Goakana: basic examples

a. à nyí má kɔ aè dɔ-è [H & C's (3b)]
he knows that he fell-LOG
 'He_j knows that he_j fell'

b. à nyí má kɔ aè dɔ [H & C's (3a)]
he knows that he fell-
 'He_j knows that he_k fell'

- However they cannot appear in a relative clause, unless the relative clause is itself embedded under an attitude verb:

(37) Ewe: relative clause

a. *ama ɔ̄ ŋku nyɔnuvi hi dze yè gbo dyi
ama set eye girl WH stay LOG side on

b. ama ɔ̄ ŋku nyɔnuvi hi dze e gbo dyi
ama set eye girl WH stay pro side on
 'Ama set eye on (remembered) the girl who stayed with her' [Clements (38)]

- c. ama gbo be yè-dɔ ŋku nyɔnuvi hi dze yè gbo dyi
ama say that LOG eye girl WH stay LOG side on
 ‘Ama; said that she; remembered the girl who stayed with her;’ [Clements (39)]

(37') Goakana: relative clause [I write I for î, A for â]

a. *lébàrèè dīb nŵín e aè de-è a gǎǎ [H&C's (35b)]
Lebare hit child that he ate-LOG his yams

b. lébàrèè dīb nŵín e aè dé a gǎǎ [H & C's (35a)]
Lebare hit child that he ate his yams

‘Lebare; hit the child_k who ate his_{i/k/l} yams’

- On a superficial analysis there might appear to be exceptions to the generalization that logophoric pronouns appear only in attitude environments:

(38) Ewe: purpose clauses

e-yi be yè-a-va-kpɔ kɔku
pro-go so that LOG-T-P-see Koku

[Clements's (34)]

‘He went to see Koku’

(38') Gokana: purpose clauses

a. lébàrèè dù kɔ baá mɔn-èè ɛ
Lebare came that they see-LOG him

[H & C's (33b)]

‘Lebare; came for them to see him;’

b. *lébàrèè dù vaá baá mɔn-èè ɛ
Lebare came and they see-LOG him

[H & C's (33c)]

The only way our theory can account for these facts is to postulate that they involve concealed attitude operators. The assumption is idle if it is a mere stipulation. But positing an attitude operator does make non-trivial predictions, such as the following:

(i) Attitude operators, like other intensional operators, yield De Re/De Dicto contrasts.

(ii) Attitude operators can shift all-purpose indexicals like ‘in two days’.

Preliminary evidence suggests that there is evidence for (i). In English purpose clauses do yield a De Re/De Dicto distinction:

- (39)a. John came (in order) to kill a unicorn . But of course there are no unicorns!
 b. #John came after killing a unicorn. But of course there are no unicorns!

The natural assumption, then, is that purpose clauses have at least in some cases an attitude reading, which makes the logophoric pronoun grammatical in these environments.²¹ As is expected, if the purpose clause is replaced with a consecutive one, logophoric agreement in Gokana becomes impossible [H & C's gloss gives 'and' for b., but they call it a 'consecutive clause', presumably because the conjunction is interpreted as 'and then']²².

(ii) Ewe and Gokana logophoric elements appear to be author-denoting

Finally, we show for completeness that Ewe and Gokana logophoric elements appear to be exclusively *author-denoting*. They will in this respect contrast with some of the logophoric pronouns that are found in Mapun.

- In both languages logophoric marking appears to be possible only if what is reported could correspond in a direct discourse to a 1st rather than to a 2nd person pronoun:

(40) Ewe: 'yè' can be used only to report a 1st person

me-gblɔ na kofi be e-du dyi [Clements's (30)]
pro-say so to Kofi that pro win
 'I told Kofi that he had won'

Direct discourse: I told Kofi: 'You have won' [presumably]

'Here the logophoric pronoun may not replace 'e' as the subject of the verb <in> the subordinate clause, even when this pronoun refers to Kofi' [Clements p. 154]

(40') Gokana: logophoric agreement can be used only to report a 1st person

a. *m̀m̀ kɔ̀ nɛ̀ lɛ̀bàrɛ̀ kɔ̀ aɛ̀ dɔ̀-ɛ̀ [H & C's (8b)]
I said give Lebare that he fell-LOG

b. m̀m̀ kɔ̀ nɛ̀ lɛ̀bàrɛ̀ kɔ̀ aɛ̀ dɔ̀ [H & C's (8a)]
I said give Lebare that he fell
 'I said to Lebare that he_i/k fell'

Direct discourse: 'You fell' [presumably]

[Note, however, that the facts given by Hyman & Comrie for Gokana are more complicated than is suggested here. 'Hear' appears to contradict our claim that logophoric marking can only be author-denoting:

(41) Gokana: logophoric agreement can be used only to report a 1st person

a. lébàrè dǎ́ m̄ gǎ́ kɔ́ aè dɔ-è
Lebare heard me mouth that he fell-LOG [H & C's (6b)]
 'Lebarej heard from me that hej fell'

[H & C's gloss for this example contains an obvious typo, which can be corrected by comparison with their (6a), which is the other member of the pair]

b. lébàrè dǎ́ m̄ gǎ́ kɔ́ aè dɔ-
Lebare heard me mouth that he fell [H & C's (6a)]
 'Lebarej heard from me that he_k fell'

Direct discourse: presumably 'You fell'

From the present perspective the contrast between 'hear' and 'tell' is rather surprising. The best we can do is postulate that 'hear' is not analyzed as a verb of communication ('be told'), but rather as a verb of thought ('come-to-think-after-hearing'). This would make a. similar to: 'Lebare thought that he fell', and thus solve the problem, since 'he' would then refer to the *author* rather than to the hearer of the reported speech act. At this point, however, this is a mere stipulation].²³

2.2. Logophoricity with Tense and Mood

We now suggest that the German Konjunktiv I can be analyzed as a logophoric tense or a logophoric mood. We do not know which one it is, but the distribution of the morpheme fits rather well with the hypothesis that it is logophoric.

First, the Konjunktiv I occurs almost exclusively in attitude environments, i.e. it is almost always used to report somebody's words or thoughts. In particular it cannot appear in conditionals, and differs in this respect minimally from the Konjunktiv II, the other subjunctive found in modern German. There are a few exceptions to the generalization, which however appear to be set phrases rather than productive patterns, at least for some speakers.²⁴

Second, semantically, the Konjunktiv I is always interpreted in the scope of an attitude operator. The following contrasts are telling (we use uninflected 'be' to gloss a Konjunktiv I):

- (42) Der Peter meint, a. es sei später, als es tatsächlich ist
the Peter thinks it be later than it really is
- b. es ist später, als es tatsächlich ist
is is
- c. * es sei später, als es tatsächlich sei
be be
- d. * es is später, als es tatsächlich sei
be be

c. implies that the agent of the attitude believes a contradiction ('it is later than it is'), while d. is ungrammatical because the than-clause has to be interpreted outside the scope of the attitude verb - but this entails that 'sei' cannot be licensed.

These contrasts can be replicated when the matrix verb is in the past tense- 'sei' can always refer to the agent's present, independently of the tense of the attitude verb. But, just as in the preceding examples, it cannot be interpreted outside the scope of the attitude operator:

(43) Situation: yesterday, at 5:00 pm, Peter thought it was already 6:00 pm

Der <i>the</i>	Peter <i>Peter</i>	meinte, <i>thought</i>	a. daß es später	war, als es tatsächlich <i>was</i>	war <i>was</i>
			b. daß es später	ist, als es tatsächlich <i>is</i>	war <i>was</i>
			c. *daß es später	ist, als es tatsächlich <i>is</i>	ist <i>is</i>
			d. *daß es später	war, als es tatsächlich <i>was</i>	ist <i>is</i>
			e. daß es später	sei, als es tatsächlich <i>be</i>	war <i>was</i>
			f. *daß es später	sei, als es tatsächlich <i>be</i>	sei <i>be</i>
			g. *daß es später	ist, als es tatsächlich <i>is</i>	sei <i>be</i>

Third, in case no overt attitude operator is present in a sentence where the Konjunktiv I occurs, one is semantically reconstructed or understood, as shown by the following contrasts (from Jäger 1971):

- (44) a. Er sagte, sie sei schön. Sie habe grüne Augen. [Jäger 1971]
He said she be pretty. She have green eyes.
- b. Er sagte, sie sei schön. Sie hat grüne Augen. [Jäger 1971]
He said, she be pretty. She has green eyes

While both a. and b. are grammatical, there is an interpretive difference between them - in a. the second sentence is taken to represent the agent's rather than the speaker's thoughts, for instance that the fact that the woman in question has green eyes is a reason given by the subject for finding her beautiful. There is no such implication in b. - the second sentence simply asserts a fact from the standpoint of the speaker.

Strikingly, exactly the same effect appears to exist in Ewe when a logophoric pronoun occurs in an environment without an overt attitude operator - in these cases it is understood that the sentence reports a thought from the standpoint of somebody else than the narrator:

(45) "The antecedent of the logophoric pronoun in Ewe need not occur in the same sentence, but may occur several sentences earlier. In such cases (...) the subsequent sentences of the discourse will continue to present the events described by the narrator from the point of view of the same individual or individuals." [Clements 1975 p. 170]²⁵

III. GENERALIZATION 3. FREE INDIRECT DISCOURSE ACROSS DOMAINS

From the study of Sequence phenomena, we learned that Sequence of Tense was not something special to the temporal domain, but had a counterpart in the person domain. But we learned more: the relevant phenomena could be replicated with English temporal adverbials, and thus did not seem to be specific to the person/tense(/mood) domain. Logophoricity, on the other hand, appeared to target *specifically* person and tense/mood. We now consider a further piece of cross-categorical evidence: in Free Indirect Discourse²⁶, a literary style studied from a linguistic perspective in Reinhart 1983, Banfield 1982 and Doron 1991, person and tense, which behaved exactly like 'tomorrow' in Sequence phenomena, take a life of their own and display a behavior which is not matched by that of temporal adverbials. In other words, elements that behaved on a par in Sequence phenomena are differentiated in Free Indirect Discourse. Crucially, however, tense and pronouns behave in one and the same way, while temporal adverbials display a different behavior (we follow Banfield's discussion in her Chapter 2, 'The Sentence of Represented Speech and Thought').

Consider some examples first:

(46) a. Tomorrow was Monday, Monday, the beginning of another school week!
[Lawrence, *Women in Love*, p. 185, London, Heinemann 1971; cited in Banfield 1982 p. 98 (her (54))]

a'. #He thought: 'Tomorrow was Monday, Monday, the beginning of another school week!'

a''. #He thought that tomorrow was Monday, Monday, the beginning of another school week!

b. Que faire? ... C'était dans vingt-quatre heures; demain!

What was there to do? It was in twenty-four hours; tomorrow!

[Flaubert, *Madame Bovary*, p. 592, Gallimard, Bibliothèque de la Pléiade, 1951; cited in Banfield 1982 p. 98 (her (54))]

b'. #Il se dit: 'Que faire? ... C'était dans vingt-quatre heures; demain!'

He said to himself: 'What was there to do? It was in 24 hours; tomorrow!'

b''. #Il se demanda que faire, et se dit que c'était dans vingt-quatre heures;

He asked himself what to-do, and said to-himself that it was in 24 hours

demain!

tomorrow!

The sentences in a. and b. are attributed to somebody other than the actual speaker, even though no attitude operator is present. Furthermore, there is evidence that no covert attitude operator is involved in this case: 'tomorrow' can never be shifted when it is embedded under an attitude verb, as in a'' and b''.; but it is clear that it is shifted in a. and b., or else the cooccurrence of 'tomorrow' and the past tense would yield a contradiction. This is the hallmark of Free Indirect Discourse, which makes it irreducible to either Direct Discourse or standard Reported Speech:

- Unlike Direct Discourse, Free Indirect Discourse does *not* reproduce the tense of the thoughts or words that are reported - even though the thought must have been of the form 'Tomorrow IS Monday' in a., the *past* tense of the verb is used in Free Indirect Discourse.
- Unlike standard Indirect Discourse, Free Indirect Discourse allows 'tomorrow' to be shifted.

The correct generalization about Free Indirect Discourse is that everything (including temporal adverbials) appears to be quoted (i.e. to appear in direct discourse), *except* tense and pronouns, which yield Sequence phenomena as if they were embedded under an attitude operator:

(47) a. Jean parlait à Marie, avec passion. Oui, vraiment, il l'aimait, et demain
Jean was-talking to Marie, with passion. Yes, really, he loved her, and tomorrow
 il l'épouserait. (Rien de tout cela n'était vrai)
he would marry her. (None of all this was true)

b. #Jean parlait à Marie, avec passion. Oui, vraiment, je t'aimais, et demain
Jean was-talking to Marie, with passion. Yes, really, he loved her, and tomorrow
 je t'épouserais.
I would marry you

c. #Jean parlait à Marie, avec passion. Oui, vraiment, il l'aime, et demain
Jean was-talking to Marie, with passion. Yes, really, he loves her, and tomorrow
 il l'épousera.
he will marry her

d. <Jean parlait à Marie, avec passion. Il disait:> 'Oui, vraiment, je t'aime, et
Jean was-talking to Marie, with passion. He said: 'Yes, really, I love you, and
 demain je t'épouserai'. (Rien de tout cela n'était vrai).
tomorrow I will marry you'. (None of all this was true).

e. Jean parlait à Marie, avec passion. Il disait qu'il l'aimait, et que
Jean was-talking to Marie, with passion. He said that he loved her, and that

le lendemain/ *demain il l'épouserait
*the day after / *tomorrow he would marry her.*

If an utterance like that in d. is reported in Free Indirect Discourse, every word can be preserved, *except* that indexical pronouns and tense must appear in the form that they would have in standard reported speech (e.). We will argue in Chapters 3 and 4 that Free Indirect Discourse involves an utterance *whose matrix context does not correspond to*

that of the actual speech act. Thus no concealed attitude operator will be posited, and we will end up with representations such as the following:

(48) Free Indirect Discourse

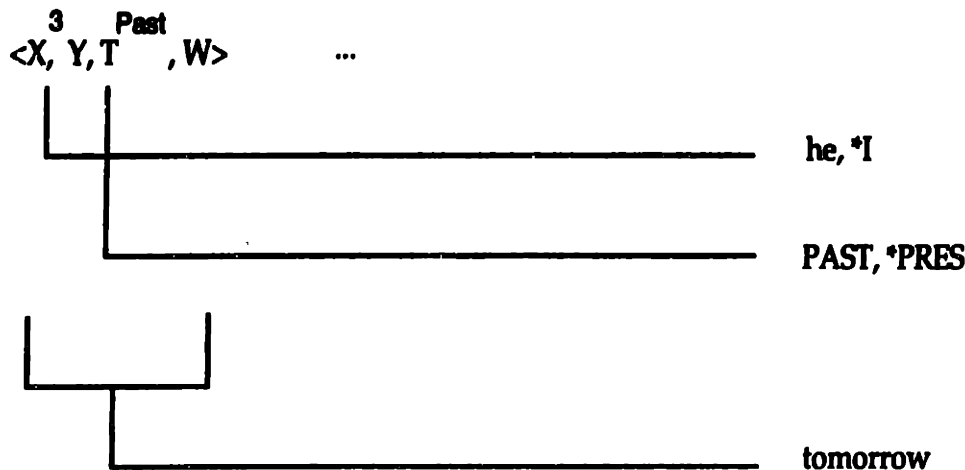

In a nutshell, the idea will be this: 'he' and PAST are (in this case) anaphoric to the author and time coordinates of the matrix context, and agree in features with their antecedents. But since X and T do not refer to the speaker and time of the actual speech act, but rather to the speech act attributed to Jean (=X) at some point in the past (=T), X and T bear respectively 3rd person and past tense features, and transmit them to the personal and temporal pronouns found in the sentence.

For present purposes, however, much less is needed. All we wanted to show was that in Free Indirect Discourse person and tense display the same idiosyncratic behavior, one which is different from that of temporal adverbials.

IV. GENERALIZATION 4. OBVIATION ACROSS DOMAINS (A SPECULATION)

More tentatively, we wish to suggest a final generalization: the tense system of English, French or German (in particular, the difference between the past and the pluperfect) has a counterpart in the person domain, to be found in languages that have obviative markers. Since the latter are not well-known, we start by listing some of the important properties of the Algonquian pronominal system.

4.1. Four Definitions of Obviation

The major property of obviative systems is that they mark a distinction between different types of 3rd person markers: a proximate one, which refers to an individual which is somehow the point of reference for a particular discourse; an obviative one, which can be seen as marking reference to some 3rd person element different from the proximate one (it might help to paraphrase the obviative marker as: 'the other'); and, in some cases, a further obviative which is different from the first two. Since I have done no fieldwork on these phenomena, the best I can do is quote people who have:

(49) Dahlstrom

'Obviation is a grammatical opposition found in the Algonquian languages which distinguishes one third person (or group of third persons) from all others. The one singled out is called proximate, and the other third persons are obviative.²⁷ The proximate third person may be the topic of the discourse, similar to what Karmiloff-Smith 1980 calls thematic subject. The proximate third person is also usually the focus of the speakers's empathy (cf. Kuno and Kaburaki 1977); in narratives, proximate often corresponds to the character whose point of view is being represented.' [Dahlstrom p. 91]

(50) Bloomfield

'In any one context, there is a distinction, among animate third persons, between proximate and obviative. Only one animate third person, be it singular or plural, is proximate; all others are in obviative form. The proximate third person represents the topic of discourse, the person nearest the speaker's point of view, or the person earlier spoken of and already known'. [Bloomfield 1962 p. 38]

(51) Frantz

'Within a narrative the major character is identified as 3; all other animate characters are subordinate to him and are identified as 4 (i.e. obviative - PS) or 5 (i.e. further obviative - PS). This serves as a focus device, for 3 is on camera and other characters are less prominent. For example, a man out hunting may be 3; an elk he sights is then 4. The narrator, wishing to describe the elk or his actions, has the option of making the elk 3, that is, shifting the focus to him, or of keeping him 4 and thereby subtly reminding the listeners that the major character, while not a participant in the immediate sentence, is still the aforementioned man. Should the elk remain 4 and the narrator mention the elk's eye, it would be 5 because it is subordinate to its possessor, elk 4. Another animal entering the scene could be 4 even though the elk is already tagged as 4.' [Frantz 1966 p. 51]

(52) Hockett

(i) 'Potawatomi nouns, pronouns, personal affixes, and noun phrases denote what I shall call *entities*. The workings of the language assign entities to the following grammatically relevant categories:

animate

local

speaker

addressee

proximate

(nearer) obviative

further obviative

inanimate

proximate

obviative'

(ii) Here is how Hockett represents the system:

Hockett's Representation of the obviative system of Potawatomi

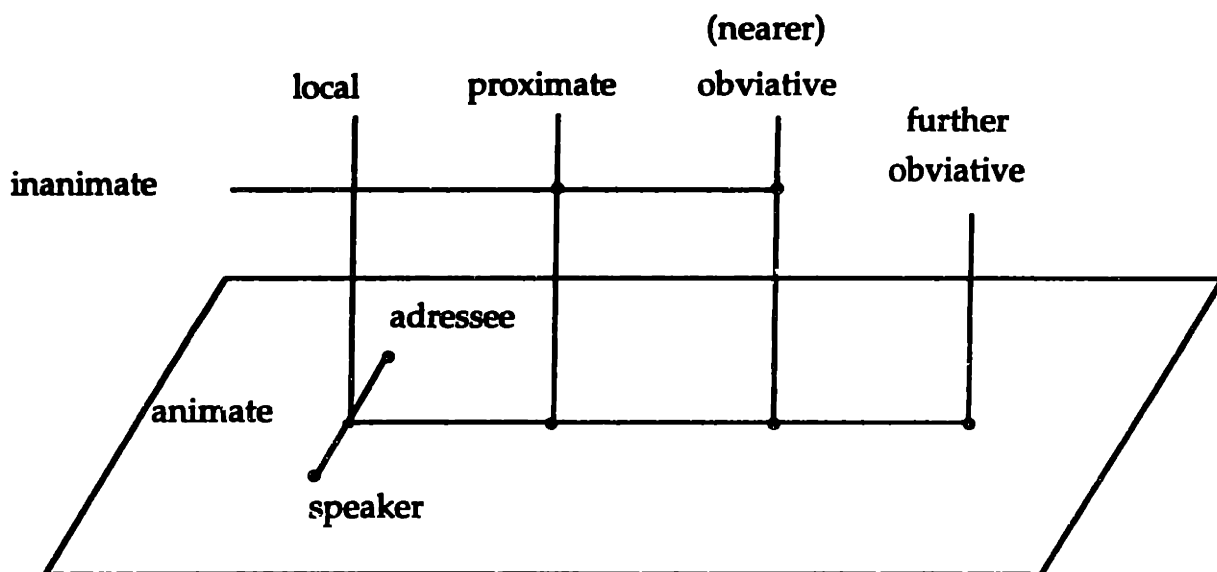

(iii) Hockett further comments:

“A basic principle of Potawatomi discourse is that within a single contextual span - the length of which is variable, usually small, but sometimes as long as several sentences - distinct entities must belong to distinct categories of those listed above, unless they stand in mere conjunction. Thus, in ‘I went for a walk and saw a bear and an elk’, the entities named by the Potawatomi equivalents of ‘bear’ and ‘elk’ will both be proximate animate; but in ‘I went for a walk and saw a bear chasing an elk’, they cannot both be proximate animate; one of the two, say ‘elk’, will instead be obviative animate. Which of two non-local animates is obviated depends on the focus of interest: the entity at the focus of interest remains proximate.’ [Hockett 1966 p. 60]

4.2. Statement of the Hypothesis

For our purposes the important property of obviative systems is that the value of an element marked as obviative must be different from that of another element (call it the ‘anchor’ of the first one) which bears proximate features. In fact things are a little more precise than this - the value of an obviative element must be *less salient* (or less *x*, where *x* is whatever discourse notion is relevant here - be it topichood, empathy, or what not) than the value of the proximate one. Similarly, the value of a further obviative must be *less salient* than the value of an obviative element. We will say that an obviative must be *anchored* to a proximate; and that a further obviative must be *anchored* to an obviative. To put it in pictures:

(53) Proximate - Obviative - Further Obviative

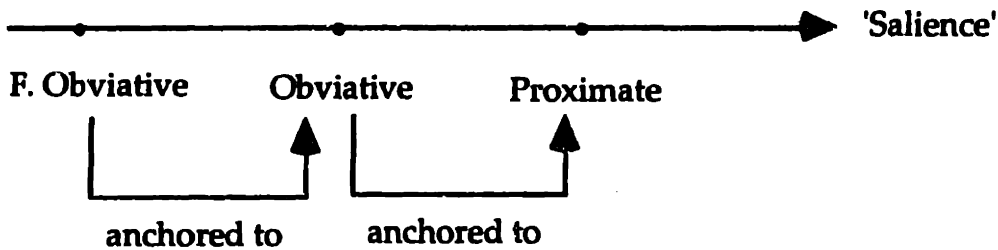

The analogy we have in mind, then, is that the distinction between Proximate - Obviative - Further Obviative in the person domain is structurally identical to that between Present - Past - Pluperfect in the temporal domain:

(54) Present - Past - Pluperfect

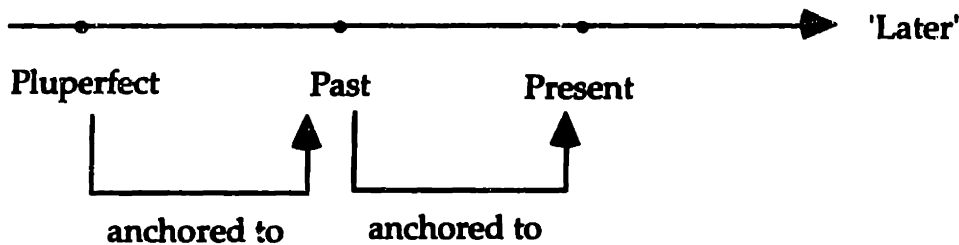

(i) The relation 'less salient than' in the nominal domain corresponds to the notion 'prior to' in the temporal one²⁸.

(ii) The grammatical categories correspond to each other in the following way:

Present	Proximate
Past	Obviative
Pluperfect	Further Obviative

Just as a past tense has to have a present tense anchor, an obviative must have a proximate anchor; and, just as a pluperfect has an anchor with past tense features, so a further obviative is anchored to an element with obviative features. [Obviously the notion of 'anchor' will have to be given a more precise definition; this is done in Chapters 2 and 3].

So far, all we have is an analogy. To have the beginning of a generalization, we need to show that several non-trivial properties are shared by both systems. Here is a first attempt.

4.3. Shared properties

(i) Meaning

Under this heading we lump together the basic semantic properties that were observed earlier - the relation between an element and its anchor, etc. From the foregoing it should be clear that these can be construed as identical in both systems, *modulo* a reinterpretation of the primitive notions.

(ii) Discourse conditions

There appear to be very few syntactic conditions on the use of an obviative form - the system seems to be driven essentially by discourse considerations. Any attempt to derive obviation from structural conditions (by analogy with Condition B effects, for instance) seems doomed, as was noted by Dahlstrom:

(55) 'Despite the examples in which NPs in topic positions are proximate, and the extension of obligatory obviation into sentential complements of a matrix verb, the examples of obviative inflection on main clause intransitives show that obviative marking cannot be predicted with a structural condition like c-command. It is also not possible to predict obviative marking on the basis of linear order of arguments'. [Dahlstrom p. 106]

As far as I know there are only two cases where a particular pattern of obviation is obligatory in a given syntactic environment:

(a) In possessive constructions, the possessor must always be marked as more 'salient' (or 'closer', as Hockett says) than the possessed²⁹

(b) In transitive constructions, one of the two arguments must be marked as more 'salient' than the other (it could be either the subject or the object; depending on which it is, the verb takes 'direct' or 'inverse' morphology).

In other cases, the choice between a proximate and an obviative form seems to be dictated by fine-grained discourse conditions which, to my knowledge, have not been formalized. All we have to go by, then, are a number of informal descriptions such as those quoted above. Consider again Frantz's illustration:

(56) " a man out hunting may be 3; an elk he sights is then 4. The narrator, wishing to describe the elk or his actions, has the option of making the elk 3, that is, shifting the focus to him, or of keeping him 4 and thereby subtly reminding the listeners that the major character, while not a participant in the immediate sentence, is still the aforementioned man. "

The description is vague, but not uninformative. Consider now a parallel example in then temporal domain:

- (57) a. Clinton was elected in 1992. And Bush was elected in 1988.
b. Clinton was elected 1992. And Bush had been elected in 1988.

mechanism is used as for the past tense, except that is applied twice [which yields: (have (had (cured))]. Now the suggestion is this: the past participle ending is simply a *temporal obviative marker*. The Yiddish present tense is simply a *proximate*. The *obviative* (=the past tense) is formed by adding to the proximate (realized as 'have') an obviative marker (=the past participle morphology). And the *further obviative* (=the pluperfect) is constructed by adding an additional obviative marker (an additional past participle ending) to the obviative form.

(iv) Semi-productivity

While both the obviative marker and the past participle ending can in some cases be iterated once, the system is in neither case truly recursive - a rather puzzling property given the possibility to have *some* iteration. The fact is very clear in the temporal domain - while it might look like all the pieces are available to make 'I have had eaten' grammatical in English, it is not. Hockett made a similar remark concerning Potawatomi in a footnote:

(71) 'In the frame of reference of generative grammar, this repeated adding of the obviative suffix begins to look like recursion. But the specified limit - not more than two obviations - is part of the language, not merely a limitation on how the speakers of the language use the language. A form with three successive occurrences of /-un/ might be uttered - but it would not be 'grammatical': it would be a paralytic, rejected by the speaker if he noticed it, interpreted by a hearer as a slip for an intended double occurrence'. [Hockett 1966, fn. 13 p. 63].

(v) Competition-based nature of the system

One final property appears to be shared by the temporal system of English (and presumably Yiddish) and by the person system of Algonquian: it is never the case that a derivation crashes for lack of the necessary morphological resources. Thus there are cases in which a further obviative would seem to be required by the grammar, although the language does not have a form for this - and in this case a simple obviative is used, and no ungrammaticality ensues. Similarly, there are cases in English in which a double pluperfect (i.e. had had eaten) would be expected, even though the form does not exist (although it does exist in other languages, for instance in Occitan). Again, in such cases the grammar simply resorts to a pluperfect, and the result does not appear to be deviant.

Consider first the possessive construction in Cree. As was noted earlier, it seems to be a general property of obviative systems that the possessor must be marked as 'more salient' ('closer') than the possessed. There is an exception to this, however - when the possessor is itself obviative, the possessed can also be obviative:

(72) "Both possessor and possessed noun may be obviative (...). There is, however, no way to express an obviative possessor and proximate possessed noun, or a proximate possessor and a proximate possessed noun" [Dahlstrom 1991 p. 97]³⁰

In other words, the patterns found in Cree are the following:

- (73) a. *possessor=obviative and possessed=proximate
 b. *possessor=proximate and possessed=proximate
 c. Ok possessor=proximate and possessed=obviative
 d. Ok possessor=obviative and possessed=obviative

Now apparently there is no further obviative in Cree. Thus the most 'distant' form available is used for the possessed when the possessor is obviative. But since no further obviative is available in Cree, a simple obviative is inserted for the possessor and the derivation does not crash.

Consider now tense in English. There are cases in which the logic of the system leads one to expect that a double-pluperfect should be used, as in the following case:

- (74) a. Five years ago, Peter told me: "Even though John arrived on Monday, Mary left on Tuesday".
 b. Five years ago, Peter told me that even though Mary HAD arrived on Monday, John HAD left on Tuesday.
 c. Five years ago Peter told me: "When Mary arrived, John had already been (# was already) out of town for five days."
 d. Five years Peter told me that when Mary HAD arrived, John HAD already been out of town for five days.

- (75) a. Il y a cinq ans, Pierre m'a dit: "Alors que Jean est arrivé lundi, Marie est partie mardi"
 b. Il y a cinq ans, Pierre m'a dit qu'alors que Jean ÉTAIT arrivé lundi, Marie ÉTAIT partie mardi"
 c. Il y a cinq ans, Pierre m'a dit: "Lorsque Jean est arrivé, Marie ÉTAIT déjà partie"
 d. Il y a cinq ans, Pierre m'a dit que lorsque Jean ÉTAIT arrivé, Marie ÉTAIT déjà partie.

a. and b. simply show that an utterance with a past tense verb must be reported in the pluperfect when the matrix verb is in the past. c. is a case in which the pluperfect is obligatory in the main clause of the direct utterance; but we see in d. that, even though we would expect it to be rendered with one additional layer of past participle morphology in d. (i.e. as 'had had left'), this does not happen and the pluperfect is used instead.

CHAPTER 2. A REVISED SEMANTICS FOR PROPOSITIONAL ATTITUDES

This chapter is an extended argument for a revised semantics for propositional attitudes, one that will allow all-purpose indexicals to be properly formalized. Whereas it is normally assumed that propositional attitude operators quantify over possible worlds, we will suggest that they quantify over contexts of speech/thought. We thus argue for the following semantics:

(1) 'John believes that p ' is true if and only if p holds in every context c compatible with John's belief [i.e. p uttered in c is true in the world of c , with $c = \langle \text{author, (hearer), time of utterance, world of utterance} \rangle$].

We first show that the problem encountered with all-purpose indexicals is in fact the other side of a well-known deficiency of the standard semantics in dealing with so-called 'De Se' readings. We then suggest that a revised semantics for attitudes, which extends Lewis's theory of Attitudes De Se, is both empirically and conceptually adequate to deal with both problems.

I. Problems with a proposition-based system

1.1. All-purpose indexicals

1.1.1. *Standard semantics for attitudes*

The problem raised by all-purpose indexicals for a standard analysis of attitudes can be summarized as follows. Hintikka's classic theory of attitudes was that a verb like 'believe' is a relation between an individual (the agent of the attitude) and a proposition, or set of possible worlds:

(2) Standard Possible Worlds Semantics

[[John believes (in w^*) that [λw the earth is flat in w]]] = true if and only for all John knows in w^* he lives in a world w s.t. the earth is flat in w , i.e. iff all worlds w that are compatible with John's beliefs are such that the earth is flat in w .

To take another example, according to Hintikka's analysis 'John says that p ' is analyzed as 'John says that he lives in a world w such that p holds at w '. But there is no mention here of a context, so that of course there is no way an indexical expression could be evaluated with respect to the context of the reported speech act.

1.1.2. *Simplified characters and the semantics of indexicals.*

Let us make things a little more precise to see what will be needed to handle all-purpose indexicals. What is the minimal machinery we need to handle indexicality in general? The hallmark of an indexical expression is that its reference changes with the context in which it is uttered. Thus if we want to formalize indexicals we need, minimally, functions from contexts to truth-values (for sentences) or to entities (for noun phrases). We call these 'Simplified characters', as they are a simplified version of David Kaplan's 'characters', which he introduced *Demonstratives* to capture context-

dependency (Kaplan used functions from contexts to *intensions*, which is more complicated; hence the simplification). We assume that contexts are characterized by 3 or 4 coordinates: <speaker, (hearer), time of utterance, world of utterance>. The knowledge speakers have of pronouns like 'I' or 'you', or present tense or indicative morphemes, can (somewhat provisionally) be formalized as follows:

- (3) a. $[[I]](c) = \text{speaker}(c)$
 b. $[[\text{you}]](c) = \text{hearer}(c)$
 c. $[[\text{PRES}]](c) = \text{time}(c)$
 d. $[[\text{INDIC}]](c) = \text{world}(c)$

Thus the truth-conditions of 'I am speaking to you' will turn out to be:

- (4) $[[[I \text{ am speaking to you}]](c) = \text{true iff author}(c) \text{ speaks to hearer}(c) \text{ at time}(c) \text{ in world}(c)$
 i.e. $[[[I \text{ am speaking to you}]] = \lambda c [\text{author}(c) \text{ speaks to hearer}(c) \text{ at time}(c) \text{ in world}(c)]$

Do we need anything else? Kaplan suggested that a more complex function was called for, one that yielded a proposition when applied to a context. And since propositions are themselves functions from worlds to truth-values, the resulting notion of meaning was two-tiered, as shown below:

- (5) Context \rightarrow [World \rightarrow Truth-value]
 Character(C) \rightarrow Content
 Content(w) \rightarrow Truth-value

On Kaplan's account, (3) receives the following analysis (we subscript 'K' to the brackets to indicate that this is Kaplan's theory):

- (6) $[[[I \text{ am speaking to you}]]_K = \lambda c \lambda w [\text{speaker}(c) \text{ speaks to hearer}(c) \text{ at time}(c) \text{ in } w]$

Applied to a context, say <John, Mary, 08.06.99, W*>, a Kaplanian character does indeed yield a proposition:

- (7) $[[[I \text{ am speaking to you}]]_K (<\text{John, Mary, 08.06.99, W}^*>)$
 $= [\lambda c \lambda w [\text{speaker}(c) \text{ speaks to hearer}(c) \text{ at time}(c) \text{ in } w]](<\text{John, Mary, 08.06.99, W}^*>)$
 $= \lambda w [\text{John speaks to Mary on 08.06.99 in } w]$

We do not see any need for this additional structure, and will thus stick in what follows to Simplified characters. This simplifying assumption is already made in Haas-Spohn 1995 and in Heim 1991, although there the terminology is slightly different. Haas-Spohn accepts Kaplan's notion of a Character, but observes that the cognitive significance of a sentence (what she calls its 'subjective meaning') is determined by something simpler, the *diagonal* of a Character. The latter notion goes back to Stalnaker 1978, who defined the following operation on (his variant of) Kaplan's Characters³¹:

$$(8) \quad \Delta[\lambda c \lambda w \chi(c)(\cdot w)] = \lambda c \chi(c)(\text{world}(c))$$

It is easy to see that the Diagonal of a Kaplanian Character is just a Simplified Character:

$$(9) \quad \Delta [[\text{I am speaking to you}]]_{\mathcal{K}}$$

$$= \Delta [\lambda c \lambda w \text{ speaker}(c) \text{ speaks to hearer}(c) \text{ at time}(c) \text{ in } w]$$

$$= \lambda c \text{ speaker}(c) \text{ speaks to hearer}(c) \text{ at time}(c) \text{ in world}(c)]$$

$$= [[\text{I am speaking to you}]]$$

[The system sketched by Heim, by contrast, seeks to dispense with Kaplanian Characters altogether, and to do everything in terms of Diagonals, that is, of Simplified Characters. One difference is that her system is based on abstraction over single variables, rather than over tuples of the form $\langle x, (y), t, w \rangle$. And of course she has no discussion of shifted indexicals, since the data we discussed in Chapter 1 were not known at the time.]

(See also Zimmermann 1991 for a very thorough discussion of context-dependency)

We now see more precisely what is inadequate in the standard semantics for attitudes. In order for embedded indexicals of the Amharic type to be interpreted, attitude operators have to quantify over contexts rather than over possible worlds. And since contexts include a world coordinate, the semantics we are suggesting is strictly more powerful than the standard one.

Interestingly, the conclusion that the standard semantics had to be enriched was reached on rather different grounds by researchers who ignored the existence of all-purpose indexicals. As we will see, however, the English phenomena that prompted the move (PRO, 'he') display the same semantic problem that we encountered with Amharic 'I' or English 'in two days', although in a different morphosyntactic guise. The heart of the matter lies in a classic of the philosophical literature, what has come to be known as the 'De Se' problem.

1.2. Attitudes De Se

The history of the problem is somewhat confusing, and it is therefore important to be clear about the 'philosophical' and the linguistic aspects of the question. The inadequacy of the standard semantics has been discussed in two rather different settings. This is because possible world semantics itself is typically used for two distinct purposes:

(i) In philosophical discussions the framework is supposed to be a tool to describe and explain attitudes of the mind like belief, desire, etc. (not the way we *talk* about these attitudes, but the attitudes themselves). Smith (or for that matter his dog Fido) is said to hope that *p* just in case he stands in a particular relation to the set of possible worlds where *p* holds, or so the story goes [obviously the nature of these 'possible worlds' is a matter of considerable debate - a debate which is of no import here, since we are solely interested in the natural language problem]. Propositions will turn out to be descriptively adequate for this task only in case every belief, desire, etc. can be adequately described as a relation between an individual and a specific proposition.

(ii) But possible worlds are also used to give a semantics for attitude operators in natural language - in other words, they are used to formalize the way we *talk* about attitudes. The condition of adequacy will be that this device must be able to encode the truth-conditions of every reading of every natural-language sentence.

As we will see shortly, the problem of 'Attitudes De Se' in the philosophy of mind shows that sets of possible worlds (propositions) are not fine-grained enough to describe the variety of real-world attitudes. But this by itself does not entail anything concerning the linguistic description of attitude operators. It is not in general the case that every category needed to describe the world corresponds to a distinct grammatical reading of natural language sentences. The De Se problem is of linguistic relevance only because it can be shown that the grammar generates De Se *readings*, i.e. syntactic representations which are different from those used for De Re readings, and which also have different truth-conditions. That such readings exist was conjectured by several philosophers in connection with 'indirect reflexive pronouns' in Ancient Greek and Latin³². In linguistically-oriented discussions, the point was made by showing that PRO and logophoric pronouns are unambiguously interpreted De Se, at least in certain environments [Morgan 1970, Chierchia 1987, Higginbotham 1989]

1.2.1. *The De Se problem in the philosophy of mind*

a) The problem

A series of articles by Castañeda, Perry, Lewis and many others attempted to establish that certain beliefs, desires, and other attitudes cannot adequately be described as relations between individuals and propositions. Briefly, the point is that one might know everything there is to know about the world and still not know where in the world one is located - so that the knowledge one lacks in such cases cannot be described in terms of propositions. Here is how Perry illustrates the problem (passage cited in Lewis 1979):

An amnesiac, Rudolf Lingens, is lost in the Stanford library. He reads a number of things in the library, including a biography of himself, and a detailed account of the library in which he is lost... He still won't know who he is, and where he is, no matter how much knowledge he piles up, until that moment when he is ready to say, "*This place is aisle five, floor six, of Main Library, Stanford. I am Rudolf Lingens.*" [Perry 1977]

Lewis comments:

"It seems that the Stanford library has plenty of books, but no helpful little maps with a dot marked "location of this map." Book learning will help Lingens locate himself in logical space. The more he reads, the more he finds out about the world he lives in, so the fewer worlds are left where he may perhaps be living. The more he reads, the more propositions he believes, and the more he is in a position to self-ascribe properties of inhabiting such-and-such a kind of world. But none of this, by itself, can guarantee that he knows where in the world he is. He needs to locate himself not only in logical space but also in ordinary space". [Lewis 1979 p. 138]

Beliefs that are irreducible to a proposition are called 'beliefs De Se'. As is clear from the previous examples, it was always apparent in the philosophical discussion that attitudes De Se arise whenever a belief is essentially indexical, i.e. whenever one could not express one's belief without using an indexical expression.

b) Lewis's property-based treatment

Lewis proposed to solve the problem by systematically replacing propositions (=sets of possible worlds) with properties (=sets of possible individuals) in the analysis of attitudes. His argument runs as follows:

(i) Properties are strictly more fine-grained than propositions - to every set of possible worlds there corresponds a property (= the property of being one of the individuals that live in one of those worlds), though the converse is not true (a proposition cannot discriminate among individuals that inhabit the same world).

(ii) One might know everything there is to know about the world without thereby knowing *where* one is located in that world, i.e. which individual one is (several well-known examples are supposed to illustrate this). Thus in some cases (e.g. in Perry's Liggins story) the object of an attitude must be taken to be a property rather than a proposition.

(iii) But given the observation in (i) this implies that one can achieve a uniform treatment of attitudes by assuming that their object is always a property.

But a property of what? one may ask. Initially Lewis suggests that one should consider properties of individuals, i.e. sets of situated (=Lewisian) individuals, individuals that exist in just one possible world. If one uses an ontology of transworld (=Kripkean) individuals, a situated individual can be identified with a pair (x, w) of a transworld individual and a possible world. Later in his discussion, however, Lewis further relativizes his notion of individuals to time-slices of world-stages of Kripkean individuals:

"Earlier I assumed that each subject of attitudes inhabits only one world, even if, as some think, persons are extended across the worlds. Now I make a parallel assumption with respect to extension through time.

Consider the insomniac. Tonight, as most nights, he lies awake for hours. While he lies awake, his state of mind changes little. He does not keep track of the time. So all through the night he wonders what time it is. (...)

To understand how he wonders, we must recognize that it is time-slices of him that do the wondering. A slice of the insomniac may locate the whole of the insomniac well enough in logical space and space and time. And yet that slice may fail to locate itself in space, in time, and in the population of slices of the well-located continuant insomniac." Lewis 1979/1983, pp. 143-144.

The result is that an attitude is now defined in effect as a relation between (temporal slice of a world stage of) an individual and a set of tuples $\langle x, t, w \rangle$ which can be seen as *contexts of thought* (x is the author, t is the time, and w is the world of the thought act).

c) Partial irrelevance of this discussion

The philosophical discussion might be of some interest, but by itself it does not have much import for the linguistic question of how to represent attitude operators in natural language. All it suggests is that the semantics of attitudes must be compatible with a De Se situation - thus if Lingens has no idea who he is, the sentence 'Lingens believes he is in the Stanford library' might still be true in case he thinks that, whoever he is, *that* person must be located in the Stanford library. But being compatible with a De Se situation is of course very different from having a De Se reading. The first requirement is fairly easy to satisfy, and in particular it does not cause any trouble for a possible world analysis of attitudes as such³³. To see this, consider for instance the (somewhat cryptic) discussion of indirect discourse in Kaplan's *Demonstratives*. Kaplan suggests that attitude operators are always defined as functions from propositions to truth values. However he recognizes that thoughts can be irreducibly indexical, so that a character rather than a proposition is taken to be what a thought is defined on. Still, the object of an attitude operator remains a proposition rather than a character. The trick is to give a semantics that mentions (in the existential mode) a Kaplanian character whose content is the proposition expressed by the embedded clause. Suppose that Lingens finally comes to believe that he (himself, whoever he may be) is in the Stanford library. Kaplan's theory will provide the following logical form, which says in essence that Lingens believes a character whose *content* is that Lingens is in the Stanford library [we modify Kaplan's presentation]:

- (10) a. Lingens believes that he is in the Stanford library
b. Lingens believes in w^* that λw Lingens is in the Stanford library in w
c. $\exists c, \chi$ [c is a context & χ is a character & Lingens is the author of c & Lingens believes a thought with character χ & $\chi(c) = \lambda w$ Lingens is in the Stanford library in w]
'Lingens believes a thought whose content is that Lingens is in the Stanford library'³⁴

Obviously according to this semantics the object of an attitude operator is, as in Hintikka's standard account, a proposition. Furthermore, Kaplan's proposal is certainly compatible with a De Se situation:

- (11) a. Lingens believes: 'I am in Stanford library'
b. Let $\chi = \lambda c \lambda w$ author(c) is in Stanford library in w . Then clearly the context $c = \langle \text{Lingens, time of his thought, actual world} \rangle$ is such that $\chi(c) = \lambda w$ Lingens is in Stanford library in w .

1.2.2. De Se readings

a) PRO is unambiguously De Se

The crucial examples for linguistic purposes are those first brought up by Morgan 1970, and first discussed in relation to the De Se problem in linguistics by Chierchia³⁵. Here is a variation on these examples:

- (12) a. Smith hopes PRO to be elected
 b. Smith_i hopes that he_i will be elected

On the face of it there isn't much difference between the two sentences, which appear to be synonymous. Consider however the following situation: Smith is so drunk that he's forgotten that he is a candidate in the election. He watches TV and sees an interview with a candidate that he finds particularly nice. So of course he hopes that *that guy* will be elected. He does not realize, however, that the person he is watching is Smith himself. Now in this (admittedly contrived) situation, one could utter truthfully b. above, but not a. a. can be true only in case Smith's hope is that the following (direct discourse) sentence be true: 'I will be elected'. This, of course, is not the case in our scenario, since Smith does not realize that he is the candidate in question. This is what has been called a 'De Se' reading [the idea being that Smith's desire is that he *himself*, whoever he may be, will be elected]. PRO in a. can only be read De Se, while 'he' in b. may either be read De Se or De Re.

The problem with a proposition-based theory is that it gives us no way to capture the difference between the De Se and the De Re readings. The standard semantics tells us that in (12) Smith hopes to live in a world w that belongs to a set P . But this is not fine-grained enough - if Smith wants to be elected, he doesn't just want to live in a world where certain things happen to certain individuals (say, Smith gets elected); rather, he wants to be one of the individuals who get elected, and depending on who he is in the world he might or might not be satisfied (he will be happy if Smith is elected, and he is Smith, or if Jones is elected while he is Jones, but not if he is Smith and Jones is elected). To make things concrete, a plausible candidate for the logical form of a. would be the following - but it wouldn't yield any difference between a De Re and a De Se reading:

- (13) a. Hope (Smith, λw [Smith BE elected in w], w^*)
 b. Every world w compatible with S.'s desire in w^* is such that S. is elected in w
 = "Smith hopes to live in a world where Smith is elected"

b) The Lewis/Chierchia solution

Since we now have an empirical argument that shows that De Se readings actually exist, we can follow Chierchia and use Lewis's property-based treatment of attitudes to formalize the behavior of attitude operators. 'Believe' is now uniformly a relation between an individual and a property:

- (14) a. Smith hopes to be elected
 b. Hope (Smith, λx x gets elected)
 = "Smith hopes to be one of the individuals who get elected"

Let us make this a little more precise. For reasons that are irrelevant here, Lewis's discussion is framed in a system where each individual exists in just one world. b. could be redundantly paraphrased as: Smith hopes to be an individual x such that x gets elected in x 's world. To facilitate the comparison between the approaches at hand, we will henceforth work within a system with transworld (=Kripkean) individuals, i.e. individuals that exist in several possible worlds. Since a Lewisian individual is just a world-slice of a transworld individual, we can identify x in the formalization above with

a pair of a transworld individual and a world. Lewis's analysis can now be re-written as:

(15) De Se, Lewis/Chierchia Solution

a. Hope (Smith, $\lambda\langle e, w \rangle$ [e BE elected in w], w^*, c^*)

[e is a variable over transworld individuals; $\langle e, w \rangle$ is a situated individual]

b. Every situated individual $\langle e, w \rangle$ compatible with S.'s desire is such that e is elected in w.

= "Smith hopes to be one of the individuals who are elected"

Lewis's theory thus provides a solution to the De Se problem. Following Chierchia, we now have a way to capture the reading of the Control structure in (7a). All we have to do is to stipulate that PRO has to be bound by a λ -abstract in Comp, as in the following:

(16) Smith hopes λi PRO_i to be elected

The point is not that we have explained why PRO is always read De Se - we haven't, we just stipulated that it is. What is new is that we now have a mechanism to capture the De Se reading, which wasn't the case in the standard theory. And PRO was crucial to provide an argument that De Se *readings* exist in natural language. [We could have used other arguments - as we will see later (following Chierchia and Kusumoto) there are in some languages overt pronouns that are exclusively interpreted De Se.]

Although the problem is solved from a technical standpoint, the connection between De Se and indexicality, which was more or less explicit in the philosophical discussion, is now lost. Specifically, if we assume both the standard semantics for indexicals, due to Kaplan, and the Lewis/Chierchia analysis of De Se, there is no obvious connection between the object of an attitude operator (=a property) and the semantic value of a sentence with indexicals (= a Kaplanian Character). The formal connection between De Se and indexicality will be reinstated in our final analysis.

c) Does 'he' have a De Se reading?

So now we know that the grammar has to generate De Se readings. And while PRO is only read De Se, 'he' seems to have the ability to be read either De Re or De Se. And in the end we will claim that this is indeed the case. However the same general problem that we observed before in relation to De Se situations vs. De Se readings reemerges with 'he' - is 'he' only read De Re, and compatible with a De Se situation, or does it also have a De Se reading?

i. The problem

To see the nature of the problem, consider the following situation (Zimmermann, p.c.):

- (17) a. **Situation:** Several drunk candidates are watching themselves on TV. Some of them hope: 'I will be elected', while others, pointing at the their own self on TV, hope: 'He will be elected'.
 b. **False:** Each candidate hopes PRO to be elected.
 c. **True:** Each candidate hopes that he will be elected

Clearly the Control structure is false in this situation, since the candidates who hope: 'He will be elected' do not have a hope De Se. On the other hand we see that 'he' can be used in this situation. Within the Lewis - Chierchia framework, the grammar provides for two readings:

- (18) Smith hopes that he will be elected
 a. De Se: Smith_i hopes that $\lambda <x_k, w>$ he_k is elected in w
 b. De Re: Smith_i hopes that $\lambda <x_k, w>$ he_j is elected in w

But certainly the reading 'he' had in (17) couldn't be the De Se one, or else the sentence would have been false (just like the Control structure is). So it must have the following structure:

- (19) [Every candidate] λx_i x_i hopes that $\lambda <x_k, w>$ x_j is elected in w

But since (17c) is true, the De Re structure has to be compatible with a De Se situation, since some of the candidates have a De Se rather than a De Re hope.

ii. Assumption: 'he' can be read De Se

But if a De Re reading is always compatible with a De Se situation, how could we ever tell whether 'he' does or does not have a distinct De Se reading? The difficulty is that every situation compatible with a De Se reading will *ipso facto* be compatible with a De Re reading as well. The argument that 'he' can indeed be read De Se is tricky, and since the discussion is rather technical, we leave it for Appendix II. At this point we simply assume that 'he' can indeed be read De Se, and defuse one possible counterargument.

The counterargument is that the assumption that 'he' can be De Se makes the formal system somewhat ugly, because it forces us to posit some *ad hoc* mechanism to explain how 'he' can have the features of the matrix subject, even though it is bound by an abstractor in the embedded clause:

- (23) Smith hopes that $\lambda <x, w>$ [x is elected in w]

But on second thought the counterargument is superficial. It is indeed correct that such a mechanism must be postulated, but this is the case independently of the analysis of 'he'. For PRO also has phi-features. In general these cannot be seen because PRO is unpronounced, but as soon as one looks at examples in which an overt element is coindexed with PRO, the phi-features become visible:

- (24) Smith hopes $\lambda <x_i, w>$ PRO_i to buy himself/*herself/*themselves a new car

Whatever it is, then, the mechanism that allows PRO to inherit the correct features in the latter example will also ensure that 'he' read De Se does as well.

Summarizing, we now have a solution to the De Se problem. But we still don't have a solution to the problem raised by all-purpose indexicals. This is rather unsurprising, since the problem was not known when Chierchia and his followers developed their framework. In fact philosophers like Kaplan had even claimed that on (more or less) principled grounds all-purpose indexicals could not exist [cf. the discussion of Kaplan's theory of demonstratives later in the chapter]. And this is a shame, since there appears to be a connection between the two problems - 'John hopes PRO to be elected' is true just in case his desire was of the form 'I will be elected'. Similarly, 'John told Mary PRO to leave' is true just in case John said to Mary something of the form 'Leave!' or 'You should leave', with an overt or understood 2nd person pronoun. Thus PRO in an object Control structure appears to be interpreted exactly like an embedded 'you' read with a shifted meaning in Aghem or Engenni. In effect, then, PRO or a 3rd person pronoun read De Se are interpreted exactly as if the indexical of the original discourse had been preserved in reported speech.

We now wish to capture the generalization that the existence of De Se readings and the problem of all-purpose indexicals are in fact two sides of the same coin - PRO or De Se 'he' are semantically equivalent to the Amharic first person pronoun when it is interpreted with respect to the context of a reported speech act³⁶. Thus our goal will be to extend the Lewis/Chierchia semantics so as to handle all-purpose indexicals and De Se pronouns in one fell swoop. To look at it from the other side, we will try to show that the semantics we need to handle all-purpose indexicals will give use an account of De Se pronouns for free.

II. PROPOSAL

A simple solution suggests itself. Since there are all-purpose indexicals, an attitude operator should be defined as a quantifier over contexts. This will give us a straightforward way of capturing De Se readings: a pronoun read De Se will be treated semantically exactly like an embedded indexical (although its syntax will be different) This theory can be seen an extension of the Lewis-Chierchia semantics for attitudes, and is particularly close to the system advocated in recent works by Haas-Spohn 1991.³⁷

2.1. The system: Utterances and Propositional Attitudes

Simplified characters give us a way to treat the semantics of indexicals. Once we have this tool, a completely straightforward theory suggests itself to handle Amharic-type embedded indexicals in attitude contexts. We can retain the standard theory of propositional attitudes, with the only difference that attitude verbs will now quantify over full contexts rather than just over possible worlds. Since contexts are identified with tuples of the form <author, (hearer), time of speech/thought, world of speech/thought>, which include a world coordinate, we will obtain a system which is strictly more powerful than the standard one. But the additional power will be fully justified from an empirical standpoint.

2.1.1. Utterances

• We assume that every utterance is a relation of predication between a (simplified) character, of the form $\lambda C P(C)$, and the context of the utterance, formally represented in the logical form as a tuple of coordinates $C^* = \langle X, Y, T, W \rangle = \langle \text{author, hearer, time of utterance, world of utterance} \rangle$. Every utterance, then, will be of the following form (a. uses an abbreviated form, and b. is the full notation):

- (25) a. $C^* \lambda C \phi$
 b. $\langle X^*, Y^*, T^*, W^* \rangle \lambda \langle X, Y, T, W \rangle \phi$

For instance, if John is talking to Mary in the actual world W^* on Aug. 13, 1999, the representation will be:

- (26) $\langle \text{John, Mary, Aug. 13, 1999, } W^* \rangle \lambda \langle X, Y, T, W \rangle \phi$

On this definition, an utterance is true just in case the (simplified) character of the sentence is true of the context represented in the prefix; this is a simple relation of predication between the character of the sentence and the context of utterance. The simplified character of the sentence gives its cognitive significance. This definition is thus seen to capture formally Frege's idea that the same semantic object accounts both for the cognitive significance of a matrix clause and for the truth-conditional contribution of an embedded clause.

• Formally, we assume that the syntax and semantics of sentences is defined recursively in whichever way the reader likes best. From a given sentence we can form what we call an 'utterance' by prefixing to the formula something of the form ' $C^* \lambda C$ '. Since we will need to distinguish between matrix and embedded contexts, we use capitalized variables for the former, and non-capitalized variables for the latter:

- (27) Variables

$X_i, x_i, Y_i, y_i, i \in \mathbb{N}$ [individuals]
 $T_i, t_i, i \in \mathbb{N}$ [times]
 $W_i, w_i, i \in \mathbb{N}$ [worlds]

- (28) Utterances

a. Syntax: If $\langle X^*, Y^*, T^*, W^* \rangle$ is a tuple of constants and if ϕ is a well-formed formula, then $\langle X^*, Y^*, T^*, W^* \rangle \lambda \langle X, Y, T, W \rangle \phi$ is an utterance.

b. Semantics: An utterance $\langle X^*, Y^*, T^*, W^* \rangle \lambda \langle X, Y, T, W \rangle \phi$ is true if and only if for every assignment s $[[\lambda \langle X, Y, T, W \rangle \phi]]_s ([[\langle X^*, Y^*, T^*, W^* \rangle]])_s = \text{true}$

2.1.2. Propositional Attitudes

- Attitude operators are analyzed as quantifiers over contexts; thus they introduce a context variable (more precisely: a tuple of variables). We could have decided to use the standard notation of First-Order Logic, with a variable 'c' (i. e. <x, y, t, w>) following the attitude operator:

- (29) a. $\forall x \phi$
 b. $\text{ATT } c \phi$

For convenience, we follow the usual practice in semantics and bind the variable by a λ -operator; it should be clear that nothing hinges on this (again we give both the abbreviated and the full notation):

- (30) a. $\text{ATT } \lambda C \phi$
 b. $\text{ATT } \lambda \langle x, (y), t, w \rangle \phi$

In case what is reported is a thought- rather than a speech-act, we will leave out the hearer coordinate ('y' in b.).

- The formation rules for Attitude operators are the following (note that attitude operators quantify over non-capitalized context variables):

(31) Attitude operators

a. Syntax: If ϕ is a well-formed formula and if ATT is an attitude operator, $\text{ATT}(x', (y'), t', w') \lambda \langle x, (y), t, w \rangle \phi$ is a well-formed formula.

b. Semantics: if s is an assignment and if ATT is an attitude operator, $[[\text{ATT}(x', (y'), t', w') \text{ that } \lambda \langle x, (y), t, w \rangle \phi]]_s$ is true iff

every assignment s' identical to s except maybe for the values assigned to $x, (y), t, w$ is $s. t.:$

$\langle [[x]]_{s'}, ([[y]]_{s'}), [[t]]_{s'}, [[w]]_{s'} \rangle \in \text{ATT}^*(\langle [[x']]_s, ([[y']]_s), [[t']]_s, [[w']]_s \rangle) \Rightarrow [[\phi]]_{s'} = \text{true}$

where $\text{ATT}^*(\langle [[x']]_s, ([[y']]_s), [[t']]_s, [[w']]_s \rangle)$ is the set of all contexts compatible with the attitude of $[[x']]_s$ (e.g. the set of all contexts compatible with what $[[x']]_s$ hopes in case we are talking about 'x' hopes that...' in $[[w']]_s$ at $[[t']]_s$)

2.1.3. Where we are going

At this point we have the main auxiliary assumption we will need to account for the generalizations involving attitudes that were stated in Chapter 1. The main component of the analysis is that attitude operators, just as utterances, introduce a

context variable in a logical form. In the next sections and chapters, we will need a distinction between *two ways* in which an element may depend on a context:

(i) Temporal adverbials that are indexical will be represented in a logical form as *functions* that take as argument a context variable (matrix or embedded, as the case may be).

Indexical Temporal Adverbials: functions

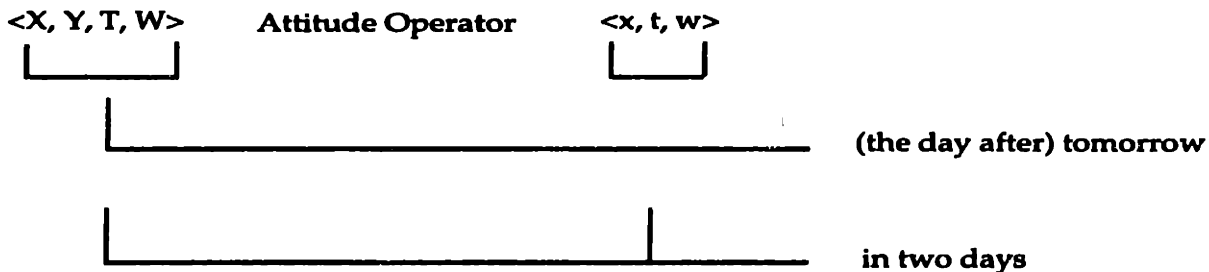

(ii) 1st/2nd person pronouns and 3rd person De Se pronouns, by contrast, will be treated as *variables bound by a coordinate of a context* (again, either matrix or embedded, depending on the case). Some uses of 'two days later ~~than it~~', of tense and of mood will be treated in the same way.

Pronouns, tense and 'two days later': bound variables

a. Pronouns

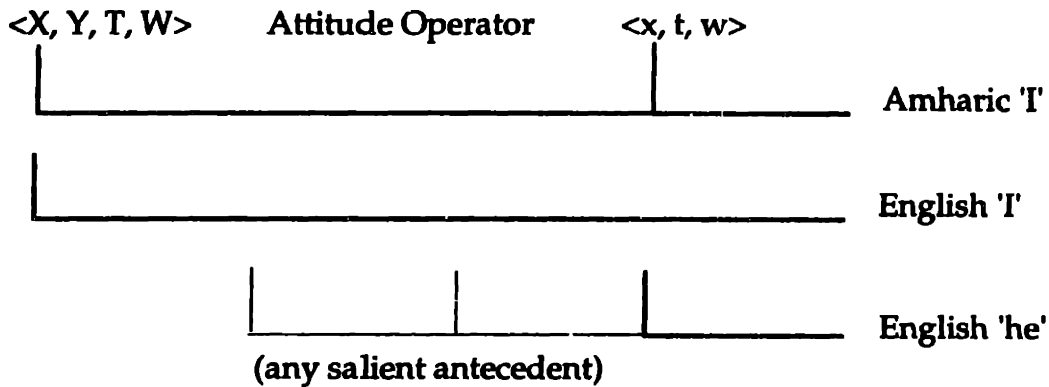

b. Tense and 'two days later'

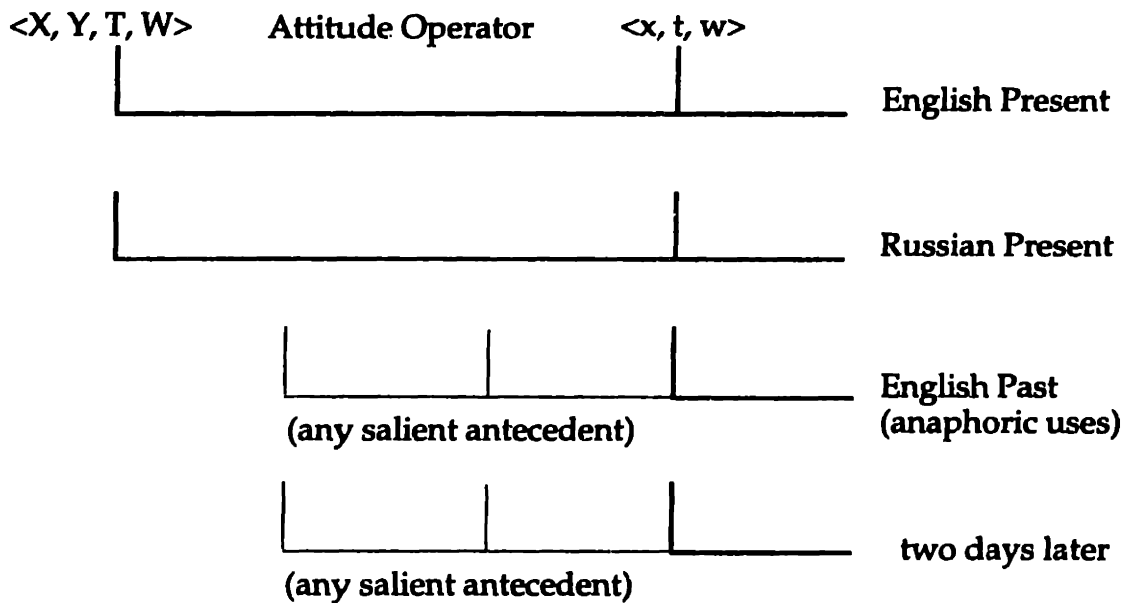

The motivation for such a differentiated treatment is empirical: in Free Indirect Discourse, temporal adverbials and pronouns/tense display different behaviors, and therefore we need *some* formal device to capture the distinction.

Since the treatment of bound variables is somewhat more involved, we now illustrate the workings of our revised semantics for attitudes with temporal adverbials. Pronouns and tense are taken up in later chapters.

2.2. Temporal Adverbials

We can now give a simple treatment of temporal adverbials. We first treat the distinction between 'in two days' and 'the day after tomorrow', and then consider 'two days later'. Pronouns and tense are treated in the following chapters.

a) 'In two days' vs. 'the day after tomorrow'

The context variable introduced by an attitude operator is never capitalized. This makes it possible to draw the crucial distinctions.

Both 'in two days' and 'tomorrow' are indexicals. We formalize them as *functions that take context variables as arguments*. But while 'in two days' may depend either a matrix (i.e. capitalized) context or on an embedded one, 'tomorrow' only takes a matrix context as argument³⁸. The important idea, then, is that in a logical form a sequence like 'tomorrow(c)', with a non-capitalized context variable, is simply *ill-formed*. By contrast, 'in-two-days(c)' will be grammatical. The following cases will therefore arise:

- (32) a. John said a week ago that it would rain in two days (embedded reading)
b. LF: $C^* \lambda C$ John said at time(C)-7 that $[\lambda c$ it would rain in two days(c)]
c. Interpretation: (a) is true iff

John said at time(C^*)-7 in world(C^*) that $[[\lambda c$ rain[in two days(c) in world(c)]], iff every context c compatible with what John said at time(C^*)-7 in world(C^*) was such that there is rain at time(c)+2.

The interpretation is unproblematic, since it is just the standard semantics for propositional attitudes, except that 'worlds' are replaced with 'contexts'. This is of course crucial to capture the indexicality of 'in two days' on the embedded reading, but does not present any further difficulties.

The reading on which 'in two days' depends on the matrix context (and is thus synonymous with 'the day after tomorrow') is entirely unproblematic:

- (33) a. John said a week ago that it would rain in two days (matrix reading)
b. LF: $C^* \lambda C$ John said at time(C)-7 that λc rain[in two days(C)] in world(c)
c. Interpretation: (a) is true iff

John said at time(C^*)-7 in world(C^*) that $[[\lambda c$ rain[in two days(C^*)] in world(c)], iff every context c compatible with what John said at time(C^*)-7 in world(C^*) was such that there is rain at time(C^*)+2 in world(c).

When we come to 'the day after tomorrow', on the other hand, it is impossible to get an embedded reading, because in the syntax the context variables (which are uncapitalized) are not of the correct variety to appear as the argument of 'tomorrow', so that the derivation crashes:

(34) a. John said a week ago that it would rain the day after tomorrow (embedded reading, which is ungrammatical)

b. LF: $C^* \lambda C$ John said at time(C)-7 that λc it would rain the day after tomorrow(c) in world(c)

=> The derivation crashes here, since tomorrow(c) is ill-formed.

The matrix reading is entirely unproblematic, and the derivation is similar to the matrix reading of 'in two days':

(35) a. John said a week ago that it would rain the day after tomorrow (matrix reading, which is grammatical)

b. LF: $C^* \lambda C$ John said at time(C)-7 that λc rain[the day after tomorrow(C) in world(c)]

c. (a) is true iff

John said at time(C)-7 in world(C) that $[[\lambda c$ rain[the day after tomorrow(C)] in world(c)]], iff

every context c compatible with what John said at time(C)-7 in world(C) was such that there is rain at time(C)+2 in world(c).

b) 'Two days later'

The simplest assumption about 'two days later' is that it involves a concealed temporal pronoun, which can be bound by any salient element. We will thus represent the expression as 'two days later than t', where t is a temporal variable.

The possibilities are the following:

(i) the concealed pronoun takes as antecedent an element of the previous discourse or of the matrix sentence

(ii) the concealed pronoun takes as antecedent the time-coordinate of the embedded context

(iii) the concealed pronoun takes as antecedent the time-coordinate of the matrix context

(iii) is excluded for reasons I do not understand [note that (iii) would be possible if we had considered 'later' rather than 'two days later'].

(i) yields a straightforward De Re reading. (ii) yields a reading on which the time referred to by 'two days later' is computed with respect to the time-coordinate of the embedded context - what we will call a De Se reading with respect to time.

- (36) a. John said a week ago that it would rain two days later (De Re reading)
 b. **LF:** $C^* \lambda C$ John said at $t'=\text{time}(C)-7$ that $\lambda \langle x, y, t, w \rangle$ it would rain two days later(t') in world($\langle x, y, t, w \rangle$)

c. **Interpretation:** (a) is true iff

John said at $t'=\text{time}(C^*)-7$ in world(C^*) that $[[\lambda \langle x, y, t, w \rangle \text{rain}[\text{two days later}(t') \text{ in world}(\langle x, y, t, w \rangle)]]]$, iff
 every context $\langle x, y, t, w \rangle$ compatible with what John said at $\text{time}(C^*)-7$ in world(C^*) was such that there is rain at $\text{time}(C^*)-7$ in w

- (37) a. John said a week ago that it would rain two days later (De Se reading)
 b. **LF:** $C^* \lambda C$ John said at $t'=\text{time}(C)-7$ that $\lambda \langle x, y, t, w \rangle$ it would rain two days later(t) in world($\langle x, y, t, w \rangle$)

c. **Interpretation:** (a) is true iff

John said at $t'=\text{time}(C^*)-7$ in world(C^*) that $[[\lambda \langle x, y, t, w \rangle \text{rain}[\text{two days later}(t)] \text{ in world}(\langle x, y, t, w \rangle)]]]$, iff
 every context $\langle x, y, t, w \rangle$ compatible with what John said at $\text{time}(C^*)-7$ in world(C^*) was such that there is rain at t in w

c) Implementation

The definition of the formal system is unproblematic. We simply introduce the following lexical entries:

(38) Lexical entries

a. 'in two days' is a function symbol that can take a matrix or a context variable as argument. Its value given an assignment s is:

$$[[\text{in two days}(C)]]_s = [[\text{time}(C)]]_s + 2$$

$$[[\text{in two days}(c)]]_s = [[\text{time}(c)]]_s + 2$$

b. '(the day after tomorrow)' is a function symbol that can only take as a matrix context variable as argument, i.e. the day after tomorrow(C) is well-formed, but the day after tomorrow(c) is not. When it is syntactically well-formed, its value given an assignment s is:

$$[[\text{the day after tomorrow}(C)]] = [[\text{time}(C)]] + 2$$

c. 'two days later' is a function defined over time variables. Where defined, its value given an assignment s is:

$$[[\text{two days later}(t)]]_s = [[t]]_s + 2$$

(41) De Se / Indexicality Generalization

An indexical can only be interpreted De Se. An anaphoric element can be interpreted either De Se or De Re.

Observe that the theory was developed purely on the basis of the distributional properties of different items, without any reference to the De Se/De Re distinction. If correct, the generalization is thus an argument for the theory developed here.

2.3. Comments

At this point the philosophically-minded might gasp. The semantics for attitudes which we just gave makes them what Kaplan calls 'monsters' - operators that can shift the context with respect to which an indexical is evaluated. Kaplan, rather optimistically, claimed that monsters do not exist in natural language. If our theory is right, it is in fact the case that *every propositional attitude operator is a Kaplanian monster*. While we defer the discussion of Kaplan's theory until the end of this chapter, we wish to claim at this point that our theory is not only empirically right, but is also conceptually motivated from a rather conservative perspective:

- (i) It can be seen as a rather trivial reinterpretation of Lewis's theory of Attitudes De Se
- (ii) It follows from Frege's considerations in 'Sense and Reference', together with a widely-accepted point made by Kaplan in his work on demonstratives
- (iii) Even on Kaplan's theory there is nothing that blocks monstrous operators from existing in the first place - in fact a stipulation is needed. All we need is to remove the stipulation, and thus simplify the theory.

(i) The final version of Lewis's theory was that an attitude is a relation between an individual and a property of time-slices of Lewisian individuals, i.e. an object of the form $\lambda\langle x, t, w \rangle \chi(x, t, w)$ [in a notation using transworld individuals]. But a triple $\langle x, t, w \rangle$ is just the context of a thought act. So if Chierchia's linguistic version of Lewis's theory had been extended according to Lewis's original insight, with abstraction over *time-slices* of individuals rather than just over (Lewisian) individuals, we would have obtained an account very close to that developed here.

-One remaining difference would be that in Chierchia's particular system there is in fact no way to single out a notion equivalent to our 'elements bound by a coordinate of an embedded context'. But this is an idiosyncrasy of his theory, not replicated for instance in the version of his system presented in Kratzer 1997.

-On a conceptual level, the important difference is that what is abstracted over in all these systems does not count (or is not called) a 'context', with the result that the conceptual connection between De Se and indexicality is obscured. On an empirical level, this had the consequence that the existence of shifted indexicals was not, to our knowledge, predicted by any of the researchers involved in the De Se problem.

-In Lewis's account there are only contexts of thought-, not of speech-acts. Therefore Lewis's contexts lack the 'hearer' coordinate which we posited whenever we were

dealing with verbs of speech rather than of thought. Certainly it is natural to have a hearer coordinate in matrix contexts in order to handle 2nd person pronouns; all we do is to extend this to those embedded contexts that are introduced by a verb of speech. And we will see in the discussion of Mapun logophoric pronouns that there is morphosyntactic evidence for this additional coordinate, since in Mapun a pronoun bound by the hearer coordinate of an embedded context takes a special form.³⁹

(ii) To see that the theory is 'conceptually' motivated, just go back to Frege. In 'Sense and Reference' Frege attempted to kill two birds with one stone: his contention was that a single notion of 'Sense' could explain both (i) why 'The Morning Star is the Evening Star' has a different cognitive value from 'The Morning Star is the Morning Star', and (ii) why 'Smith believes that the Morning Star is the Morning Star' does not entail 'Smith believes that the Morning Star is the Evening Star'. The key was that a Fregean sense gives both the cognitive (non purely truth-conditional) value of a main clause, and the truth-conditional contribution of an embedded clause in an intensional context. Now a number of philosophers, for instance Kaplan, have shown that the cognitive value of a main clause was crucially related to its context-dependency. Consider Kaplan's example:

(42) 'If I see, reflected in a window, the image of a man whose pants appear to be on fire, my behavior is sensitive to whether I think, 'His pants are on fire', or 'My pants are on fire', though the object of thought may be the same [i.e. the proposition expressed may be the same, P.S.]'.

In Kaplan's framework, as well as in our modification of it, this example shows that what accounts for the cognitive value of a main clause is a Character rather than a standard proposition. But on Frege's story whatever object yields the cognitive value of a main clause should also account for the truth-conditional contribution of an embedded clause. Therefore the truth-conditional contribution of an embedded clause should also be given by a Character - which was precisely our conclusion.

(iii) Third, observe that as soon as one introduces Characters (whether simplified or not), one allows in principle for the possibility that operators could affect them in all sorts of ways. In fact Kaplan needs a stipulation to prevent this, since as he himself notes in 'Demonstratives monstrous operators are perfectly well-formed from a logical standpoint. All we say, then, is that there is no need for this stipulation - it complicates the theory unnecessarily, and is empirically incorrect.

Finally, we note that many of these points were already conjectured in Israel & Perry's 'Where Monsters Dwell' - in particular they observed that Kaplan's ban on monsters was nothing more than a stipulation, and that one might expect to find monsters in the attitude domain. While they did not know of examples of monstrous ('all-purpose') indexicals, their conjecture was exactly correct, and essentially for the right reasons.⁴⁰

III. Ross's Generalization and the Performative Analysis

In this section we provide further evidence for our revised theory of propositional attitudes. The argument, based on a paradigm discovered by Ross 1970, runs as follows:

(i) The main thesis of our revised analysis of attitudes is that attitude operators introduce context variables.

(ii) This, in turn, entails that elements that are in the scope of an attitude operator (and thus semantically dependent on an embedded context) should be in some respects similar to garden-variety indexicals, which depend on a *matrix* context. The prediction is that there should be a natural class that includes *those elements that are semantically dependent on a context (be it matrix or embedded)*.

(iii) A set of facts discussed in Ross 1970 suggests that this is indeed correct. 'Ross's Generalization', as we call it, shows that 3rd person pronouns embedded under an attitude operator behave with respect to a certain rule R *exactly as 1st (or to some extent 2nd) person pronouns that are unembedded*.

(iv) Furthermore, we show that the revised analysis of attitudes makes a prediction not made by Ross's system: the Generalization should hold *only in case a 3rd person pronoun is read De Se*. The prediction turns out to be borne out, which provides further evidence that 'he' can (among others) have a De Se reading.

We compare our solution to Ross's 'Performative Analysis' towards the end of the chapter.

3.1. Ross's Generalization

3.1.1. First Person Cases

In 'On Declarative Sentences', Ross observed a number of striking similarities between 1st and 2nd person on the one hand, and 3rd person pronouns embedded under an attitude verb on the other. His most remarkable examples involved reflexivization of a pronoun in the absence of a local antecedent:

(43) [Ross's (21); his judgments, with my informant's judgments inside brackets where they differ]

- a. This paper was written by Ann and myself.
- b. ?? This paper was written by myself.
- c. ? Ann and myself wrote this paper. (D. Embick: ??)
- d. *Myself wrote this paper.
- e. ? The lioness may attack Ann and myself.
- f. *The lioness may attack myself. [Ross's (21)]

(44) [Ross's (22); his judgments, with my informant's judgments inside brackets where they differ]

- a. Tom believed that the paper had been written by Ann and himself.
- b. ?? Tom believed that the paper had been written by himself.
- c. ?Tom believed that Ann and himself had written the paper.(D. Embick: ??)
- d. *Tom believed that himself had written the paper.
- e. ?Tom believed that the lioness might attack Ann and himself.
- f. *Tom believed that the lioness might attack himself.

Within our framework, there is a simple way of stating the generalization, since what is common to all these cases is that they involve pronouns *that are dependent on a context*, as represented below [at this point we simply stipulate that the pronouns under study are *bound by a coordinate of a context*; this will be justified in the next chapter]:

- (45) a. $\langle X^*, Y^*, T^*, W^* \rangle \lambda \langle X_i, Y, T, W \rangle$ This paper was written by Ann and myself_i.
b. $\langle X^*, Y^*, T^*, W^* \rangle \lambda \langle X, Y, T, W \rangle$ Tom believed that $\lambda \langle x_i, t, w \rangle$ the paper had been written by Ann and himself_i.

3.1.2. Second Person Cases

Ross noted in a footnote (footnote 19 on p. 263) that 'yourself' appears, with the same spectrum of acceptabilities, in *questions* that are analogous to the sentences' in (49) [his (21)]. Later in the paper, he observed that for some speakers (not him) sentences like the following were possible:

- (46) ?? This paper was written by Ann and yourself. [Ross's (89)]

He conjectured that for these speakers the embedded equivalent of the sentence should also become possible:

- (47) ?? Ted told Sarah_i that the paper had been written by Ann and herself_i

Very preliminary empirical work indicates that the 2nd person examples are indeed more degraded than the 1st person ones. In fact this also appears to hold for questions, which according to Ross's footnote are grammatical. Still, the contrasts in (43) and (44) can to some limited extent be replicated in the 2nd person case (I have changed 'by yourself' into 'for yourself' in order to make the examples more plausible - it would be rather odd to inform X that a given letter had been written by him). [The following are D. Embick's judgments]

- (48) a. ?? This paper was written for Ann and yourself.
a'. *This paper was written for Ann and himself.
b. *This paper was written for yourself.
c. *Ann and yourself wrote this paper
d. *Yourself wrote this paper.
e. ?? The lioness might attack Ann and yourself
f. *The lioness might attack yourself

- (49) a. ?? Was this paper really written by Ann and yourself?
 b. *? Was this paper really written by yourself?
 c. *? Did Ann and yourself really write this paper?
 d. *Did yourself really write this paper?
 e. ?? Did the lioness really attack Ann and yourself?
 f. *Did the lioness attack yourself?
- (50) a. ? I told John that the paper had been written for Ann and himself
 b. *? I told John that the paper had been written for himself
 c. *? I told John that Ann and himself had written the paper
 d. * I told John that himself had written the paper.
 e. *? I told John that the lioness might attack Ann and himself
 f. * I told John that the lioness might attack himself.
- (51) a. ? I asked John whether the paper had really been written by Ann and himself.
 b. ?? I asked John whether the paper had really been written by himself.
 c. *? I asked John whether Ann and himself had really written the paper.
 d. * I asked John whether himself had really written the paper.
 e. ?? I asked John whether the lioness had really attacked Ann and himself.
 f. * I asked John whether the lioness had really attacked himself.

Again, there is a simple way to re-state the facts within our framework: a rule of non-local reflexivization is allowed to apply (marginally) whenever an element is bound by the hearer coordinate of a context - as shown below:

- (52) a. $\langle X^*, Y^*, T^*, W^* \rangle \lambda \langle X, Y_i, T, W \rangle$ This paper was written by Ann and yourself_i.
 b. $\langle X^*, Y^*, T^*, W^* \rangle \lambda \langle X, Y, T, W \rangle$ Ted told Sarah that $\lambda \langle x, y_i, t, w \rangle$ the paper had been written by Ann and herself_i.

3.1.3 The Generalization

We can now give a preliminary statement of Ross's Generalization:

- (53) A pronoun bound by the author of a context (be it matrix or embedded) can optionally be reflexivized in the absence of a local binder. Reflexivization of a pronoun bound the the hearer coordinate of a context is also marginally possible.

Obviously we have not *explained* why Ross's Generalization should hold. Nor had Ross done so. For him, just as for us, the interest of the generalization was to show that a natural class must be defined which comprises 3rd person pronouns interpreted in the scope of an attitude operator, and 1st and 2nd person pronouns. This, in turn, lends support to a theory that treats these elements in a uniform way (here, as bound by a coordinate of a context)⁴¹.

3.2. Comparison with Ross's 'Performative Analysis'

1. In order to account for his generalization, Ross proposed that every declarative clause was in fact embedded under an abstract performative verb like 'I declare to you that...'. Thus 'Prices slumped' is analyzed as '~~I DECLARE (to) you~~ prices slumped', with deletion of the matrix clause:

(54) Ross's performative analysis [his (6) and (7)]

a. Prices slumped.

b.

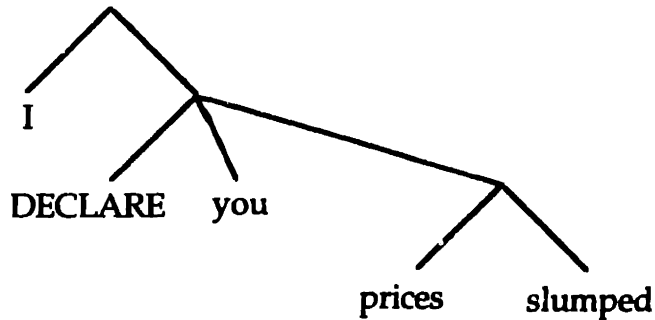

where DECLARE :=

+V
+performative
+communication
+linguistic
+declarative

[DECLARE is my notation; Ross uses the matrix of features instead. Note that DECLARE cannot itself be embedded; this is because, as Ross observes, a verb cannot have a performative interpretation 'when it is embedded as the complement of another verb' (p. 251) - and since DECLARE contains the feature +performative, it can't be further embedded - which saves the analysis from infinite regress]

The leading idea of his analysis was that his generalization could be captured by positing that 'I' in the first set of examples was, despite appearances, itself embedded under a propositional attitude verb. And indeed his analysis makes the 1st person and the relevant 3rd person cases entirely similar:

- (55) a. ~~I DECLARE (to) you~~ this paper was written by Ann and myself_i.
 b. Tom_i believed that the paper had been written by Ann and himself_i.

For comparison, here is a (somewhat) simplified version of the analysis we will give of when we have more fully developed our system:

- (56) a. $\lambda < X_i, Y, T, W >$ this paper was written by Ann and myself_i.
 b. $\lambda < X, Y, T, W >$ Tom believed that $\lambda < x_i, t, w >$ the paper had been written by Ann and himself_i.

2. There is an important similarity between our analysis and Ross's, since in both cases 'he' can behave like 'I' (or for that matter like 'you', as we will see later) just in case it is embedded under an attitude verb. The difference, however, is that Ross captures the generalization by embedding matrix clauses under an attitude verb. By contrast, in our system matrix clauses are unembedded, but both matrix and embedded clauses start with an abstraction over a contextual variable [$\lambda\langle x, t, w \rangle$ or $\lambda\langle X, Y, T, W \rangle$]. (In more standard accounts [e.g. Kaplanian ones] it is only at the level of the matrix clause that the contextual variable is abstracted over, which would make it hard to capture the generalization.) So we now have two ways to account for Ross's generalization. Which one is correct?

(i) Ross's Performative Analysis makes it easy to state the generalization. But so does our theory. In this respect, then, there is no difference between the two theories. However in other respects the contenders are not equal. For example, the distinction between De Se and non-De Se readings, which our theory has no trouble handling, is problematic for Ross. In his system an embedded pronoun has just one possible antecedent (the matrix subject or indirect object, depending on the case). On our theory there are always 2 possible antecedents, and this correctly derives the existence of two separate readings:

- (57) a. Tom_i believed that he_j had written the paper.
 b. $\langle X, Y, T, W \rangle$ Tom_i believed that $\lambda\langle x_k, t, w \rangle$ he_j, k had written the paper.

In addition, there are so many differences between embedded and unembedded clauses that Ross's theory would definitely have to be supplemented with a device that draws the relevant distinctions. To take but one example, 'tomorrow' can be evaluated with respect to a matrix context, but not with respect to an embedded one. And adding the necessary distinctions would greatly complicate the statement of Ross's theory.

(ii) The two theories make subtly different predictions. Within our system it is only a 3rd person *read De Se* which should behave like an unembedded pronoun - a De Re pronoun would not be bound by a coordinate of a context, and should thus behave like pronouns that appear in extensional environments. Ross's system makes no such prediction - in fact it is not even clear how it could capture De Se readings in the first place. Our prediction appears to be borne out, since all examples become sharply ungrammatical in a non-De Se situation:

(58) Situation: Tom is studying a certain manuscript, whose author he seeks to identify. He is given a number of writing samples to compare the manuscript with. He eventually matches the paper with a particular sample which, unbeknownst to him, is in his own handwriting.

- a. *Tom believed that the paper had been written by Ann and himself.
 b. *Tom believed that the paper had been written by himself.
 c. *Tom believed that Ann and himself had written the paper.
 d. *Tom believed that himself had written the paper.
 e. *Tom believed that the lioness might attack Ann and himself.
 f. *Tom believed that the lioness might attack himself.

This piece of empirical evidence clearly favors our treatment over (a simple version of) Ross's Performative Analysis. It also provides an additional argument for positing that 'he' is ambiguously De Se or De Re rather than unambiguously De Re, since in the latter case we would have no way of stating the generalization.

(iii) Finally, observe that our theory is not as such incompatible with a performative analysis. We could give of Rossian version of our system, for instance along the following lines:

- (59) a. ~~I DECLARE (to) you~~ $\lambda <x_i, y, t, w>$ this paper was written by Ann and myself_i.
b. ~~I DECLARE (to) you~~ $\lambda <x', y', t', w'>$ Tom believed that $\lambda <x_i, t, w>$ the paper had been written by Ann and himself_i.

Some of the facts that Ross mentions toward the end of his article are not amenable to our treatment without this additional device - for instance the optional appearance of the complementizer '?inna' at the beginning of every declarative sentence in Arabic is not a fact that follows from the presence of the contextual prefix $<X, Y, T, W>$ on every matrix clause. [One could attempt to reinterpret the Arabic complementizer as the spell-out of a context variable/parameter, but I have no idea whether this is in any way plausible].

generalization. Given that the context of 'in two days' can also be shifted by any attitude verb in English, it seems to be quite generally the case that attitude operators are Kaplanian monsters⁴².

APPENDIX II. 'HE' CAN BE READ DE SE

How can we learn whether 'he' is unambiguously read De Re, or whether it can either be De Re or De Se? The source of the difficulty was that the De Re reading appeared to be compatible both with a De Se and with a non-De Se situation (the relevant examples are repeated for convenience):

(1) a. **Situation:** Several drunk candidates are watching themselves on TV. Some of them hope: 'I will be elected', while others, pointing at the their own self on TV, hope: 'He will be elected'.

b. **False:** Each candidate hopes PRO to be elected.

c. **True:** Each candidate hopes that he will be elected

(2) [Every candidate] $\lambda x_j x_j$ hopes that $\lambda \langle x_k, w \rangle x_j$ is elected in w

The argument was that since c. is true, and some of the candidates clearly have a non-De Se attitude, the logical form of the sentence should be the one in (2), with a De Re rather than a De Se reading. But since some of the candidates also have a De Se attitude, the De Re reading must be compatible with a De Se situation. The hypothesis was that it is in fact *always* the case that a De Se reading entails a De Re one, with the consequence that it is very hard to argue that 'he' does indeed have a separate De Se reading.

We explore three types of arguments that suggest that 'he' can in fact be read De Se:

I. Preference for De Se over De Re structures

Even on the assumption that a De Re reading is always compatible with a De Se situations, it can be shown that in languages that distinguish De Se elements from De Re pronouns the De Re pronoun is highly dispreferred in unmarked contexts if the De Se structure can be used. But in the same situations 'he' does not appear to be dispreferred, which suggests that it can be read De Se.

II. Cases where De Se does not entail De Re

The hypothesis that a De Se reading always entails a De Re one can be challenged. There exist (complex) situations in which a structure which is uncontroversially De Se (one involving PRO) is true, even though a De Re version of the sentence isn't. In these cases 'he' can freely replace PRO, which suggests that it too can be read De Se.

III. Syntactic argument

Finally we observe that Ross's Generalization provides a syntactic argument for the availability of a De Se reading for 'he'.

- a. John believes that his pants are on fire
 b. John wà?àtə mə *yɪ/à ká khi (Kusumoto)
John thinks that self/he FUT burn
 'John thinks that he is going to get burnt'

(Note that this argument can go through only if Bafut logophoric pronouns behave like their Ewe counterparts, and yield disjoint reference effects in an unmarked context).

• In English, on the other hand, 'he' under an attitude verb never yields disjoint reference effects with the matrix subject, even if PRO can be chosen instead:

- (5) a. John_i hopes he_j will be elected
 b. John_i hopes PRO_j to be elected

2. Epithets

The same argument can be made within English from a comparison between 'he' and what Dubinsky & Hamilton 1998 call 'antilogophoric pronouns'. These, we will assume, are simply an English version of the De Re pronoun in Ewe. And just as their Ewe counterpart they yield disjoint reference effects *just in case they appear in the scope of an attitude verb*. The argument will thus be the same as before: if 'he' were only read De Re, it would behave like other De Re pronouns, and yield a disjoint reference effect under an attitude verb. But it does not, and must therefore have a De Se reading.

But, one may ask, what is an 'antilogophoric pronoun' in English? Dubinsky & Hamilton suggest that this is just what an epithet is. Their crucial observation is that epithets are not just (like pronouns) subject to Condition B of the Binding Theory. They can also be bound (in the syntactic sense: coindexed with and c-commanded by some element), contrary to what has been assumed in the literature so far. The only reason researchers didn't see this before is that epithets are antilogophoric, and thus may not be bound by the agent of an attitude verb. For the rest, they behave like simple pronouns. Here are some of Dubinsky and Hamilton's examples [their (12-14)]:

- (6) a. John_i ran over a man (who was) trying to give the idiot_j directions.
 b. Through an accumulation of slipups, John_i (inadvertently) led his students to conclude that the idiot_j couldn't teach.

- (7) a. *It was said by John_i that the idiot_j lost a thousand dollars on the slots.
 b. It was said of John_i that the idiot_j lost a thousand dollars on the slots

In (7a) the epithet cannot be used because it would denote the author of the reported thought act. By contrast, since John is not the author of the reported speech act in (7b), the epithet can freely appear in the embedded clause.

Dubinsky & Hamilton frame their analysis within Sells's theory of Logophoricity, which does not establish any connection between logophoric pronouns and De Se readings. But this step is an easy one to take within the present framework. This predicts that epithets, i.e. English De Re pronouns, should *fail* to yield disjoint reference effects when a non-De Se situation is set up. This appears to be correct (D. Embick's judgments):

(8) a. Unmarked situation

#John_i is convinced that that [the idiot]_j's voice is too aggressive

b. Non-De Se situation

John hears on tape several people's voices. He must determine whose voice could be used for some advertisement. He finds that a certain person's voice sounds too aggressive for the task, without realizing that the person in question is John himself. [Variation on Reinhart 1991]

John_i is convinced that that [the idiot]_j's voice is too aggressive

3. *Kuno Effects*

In Kuno 1972, it is suggested that there is some preference for using a pronoun rather than an R-expression to report in indirect discourse what would involve a 1st or a 2nd person pronoun in direct discourse. The judgments are rather subtle, and the conditions under which they hold are not entirely clear. But if there is indeed an effect, the natural suggestion would be that a De Se reading must be preferred over a De Re one whenever there is a choice. Since R-expressions can never be read De Se, we could capture Kuno's generalization by postulating that 'he' can be read De Se. On the other hand if 'he' were only read De Re, Kuno's effects would be entirely unexpected. Here is a simplified version of Kuno's paradigm (his judgments; my informants have weak contrasts):

- (9) a. John_i expects that he_j will be elected
b. That he_j will be elected is expected by John_i
c. *That John_i will be elected is expected by him_i

- (10) a. John_i claimed that he_j was the best boxer in the world
b. That he_j was the best boxer in the world was claimed by John_i
c. *That John_i was the best boxer in the world was claimed by him_i

The form of Kuno's argument (somewhat modernized) is that no binding-theoretic violation occurs in the c. examples. Still, the R-expressions are ungrammatical. If the facts are correct, we can re-state them as a preference for the De Se over the De Re option in these examples. We leave it for future research to determine (i) how real Kuno's paradigm is, and (ii) whether his generalization can be derived⁴³.

II. Cases in which De Se does not entail De Re

In order to analyze the source of the problem we are trying to solve with 'he', we have to be a little more explicit about what De Re readings are. Quite generally there is a difficulty when it comes to determining what it means to have a De Re belief or hope about anything. This is exemplified in Quine's 'Orcutt' problem - we can say of Orcutt both that Ralph believes that he is a spy [*qua* the man in the brown hat], and that Ralph believes that he is not a spy [*qua* the man seen at the beach]. The point of the example is that Ralph does not hold contradictory beliefs, since he does not realize that the man

in the brown hat and the man seen at the beach are one and the same. But how are we to avoid ascribing irrationality to Ralph? If he were to believe that he is in a world (or for that matter in a context) in which Ortcutt is a spy, and also in a world (in a context) where Ralph is not a spy, he would believe... the empty proposition. The solution offered by Kaplan was to reintroduce in the analysis the guises under which Ralph believes that Ortcutt is or isn't a spy. In Lewis's framework, this means the following:

"A subject ascribes property X to individual Y under description Z if and only if
 (i) the subject bears the relation Z uniquely to Y, and
 (ii) the subject self-ascribes⁴⁴ the property of bearing relation Z uniquely to something which has property X."

(11) a. Ralph believes that Ortcutt is a spy

b. $\exists \alpha R(\text{Ralph}, \text{Ortcutt}, w^*, \alpha) \ \& \ \text{Ralph believes } \lambda \langle x, w \rangle [\text{ty } \alpha(x, y, w)] \text{ is a spy in } w]$

= There is a 'vivid' relation of acquaintance α between Ralph and Ortcutt in the actual world w^* such that Ralph believes he is an individual x living in a world w such that the person who stands in the relation α to x in w is a spy in w

Note that not any description will do. If Ralph believes: 'The shortest spy is a spy', and Ortcutt happens to be the shortest spy, the claim that 'Ralph believes that Ortcutt is a spy' will be false. In Kaplan's terminology, 'the shortest spy' is not a description which is 'vivid' for Ralph [no definite criterion is offered to determine whether a name is 'vivid' or not; nor is it clear that one should be given - the notion is presumably highly context-dependent]

Let us assume, on the other hand, that the relation one has with oneself, 'self-identity', is always a 'vivid' acquaintance relation. This would entail that an attitude De Se is always *ipso facto* also an attitude De Re. Consider our Control example:

(12) a. Smith hopes PRO to be elected

b. Smith hopes $\lambda \langle x, w \rangle [x \text{ is elected in } w]$, therefore:

c. Smith hopes $\lambda \langle x, w \rangle [\text{ty } \alpha(x, y, w) \text{ is elected in } w]$ with $\alpha(x, y, w) := [x=y \text{ (in } w)]$, and hence:

d. $\exists \alpha R(\text{Smith}, \text{Smith}, w^*, \alpha) \ \& \ \text{Smith hopes } \lambda \langle x, w \rangle [\text{ty } \alpha(x, y, w) \text{ is elected in } w]$

So if self-identity is considered to be a vivid acquaintance relation, c. entails d. And since b. always entails c., b. also entails d. - which is just to say that a De Se reading systematically entails a De Re one:

(13) Smith hopes that $\lambda \langle x, w \rangle [x \text{ is elected in } w] \Rightarrow \text{Smith hopes that } \lambda \langle x, w \rangle [\text{Smith is elected in } w]$

This, of course, is the reason 'Every candidate hopes that he will be elected' can be true in a mixed situation (De Se for some candidates, non-De Se for others): '[Every candidate] $\lambda x_i x_i$ hopes that $\lambda \langle x_k, w \rangle \text{ he}_i \text{ is elected in } w$ ' has a De Re reading, and is thus compatible both with a De Se and a non-De Se situation.

But is it so clear that a De Se reading *always* entails a De Re one? All we have done so far was to generalize from one example, and stipulate that since De Se entails De Re in one situation, it does so quite generally. But it is not clear that this is correct. Two arguments should be made at this point. One is conceptual: on standard theories of De Se readings, a *stipulation* is needed to ensure that the purported entailment holds. If we drop the stipulation, we expect that in at least *some* cases a De Se reading should fail to entail a De Re one. The other argument is empirical: as a point of fact there do seem to be cases in which De Se does not entail De Re.

- First, observe that (as we saw earlier) the reason a De Se reading normally entails a De Re one is that self-identity appears to always count as an acquaintance relation (i.e., in Kaplan's terminology, self-identity is always a 'vivid' relation). If correct, this is a brute fact which does not follow from anything else in the theory. In order to obtain the correct inference in our previous example we had to rely on the following step from c. to d.:

- (13) c. Smith hopes $\lambda \langle x, w \rangle$ [$\exists y \alpha(x, y, w)$ is elected in w] with $\alpha(x, y, w) := [x=y \text{ (in } w)]$, and hence:
 d. $\exists \alpha R(\text{Smith}, \text{Smith}, w^*, \alpha)$ & Smith hopes $\lambda \langle x, w \rangle$ [$\exists y \alpha(x, y, w)$ is elected in w]

But this step is valid only if there is a general principle of the form:

- (14) Let w^* be the actual world. Then for every individual x^* ,
 $R(x^*, x^*, w^*, \lambda x \lambda y \lambda w x=y \text{ (in } w))$
 'Self-identity is an acquaintance relation (a 'vivid' relation)'

One might try to argue that it is somehow 'conceptually necessary' or 'natural' that self-identity should always be a 'vivid' relation (maybe because agents of attitudes are assumed to have a direct cognitive access to themselves). However there are cases in which a De Se reading does not involve a relation between an agent and himself, but rather between an agent and a person he or she addresses. Consider the following case of object control⁴⁵:

(14) Situation: At a party John is told that Mary is obnoxious. Reporting on what he just learned he says to the lady he is talking to: 'Mary should leave'. That lady happens to be Mary herself.

- a. **True:** John told Mary that she should leave
- b. **False:** John told Mary PRO to leave

What is interesting in this example is that the Control case does not correspond to something which, in direct discourse, would involve a first-person pronoun, but rather a second person pronoun. Thus b. could be true only if what John had told Mary was of the form 'Leave!' or 'You should leave!', but not 'Mary should leave'. PRO has to be interpreted De Se or, rather, 'De Te'⁴⁶. Now just as in the subject Control cases that were observed earlier, 'he' is certainly compatible with a De Se ('De Te') situation - if John told Mary: 'Leave!', we could relate the event with: 'John told Mary that she should leave' just as well as with: 'John told Mary to leave'. Now consider the De Re

construal. What is the relation that holds between John and Mary? The example is perfectly compatible with a situation in which John had no idea who he was talking to. So at least in this case the relation must be something like: 'the person John is talking to'. But why should *that* always count as a 'vivid' relation (as an acquaintance relation)? Again, we could use a postulate to enforce this, but it is very unclear why the postulate should hold in the first place: with a little imagination it is easy to think of relations of address in which *the agent has no idea who he is talking or writing to*. Why should these necessarily be 'vivid' relations?

- Let us now see what the facts are. Consider the following scenarios:

(15) (i) Situation 1: In 1867, Anna Smith left a note for the eldest of her great-grandchildren, in case she was to have any. The note read: 'Behave!'. Peter Smith is this person, and finally gets the note.

- The note says to Peter Smith PRO to behave
- #The note says to Peter Smith that Peter (Smith) should behave
- #The note says that Peter (Smith) should behave.
- The note says to Peter Smith that he should behave.

(ii) Situation 2: Yesterday, Anna Smith left a note for her grandson Peter Smith. The note read: 'Behave'

- The note says to Peter Smith to behave
- The note says to Peter Smith that Peter should behave
- The note says that Peter Smith should behave
- The note says to Peter Smith that he should behave

Situation 1 appears to be one in which there is no 'vivid' relation between Anna Smith and Peter Smith - presumably because Anna Smith had already long died when Peter Smith was born. Thus b. and c. are deviant / false. By contrast, a., which involves a Control structure, is perfect. But the Control structure can only be read De Se; while b. and c. could only be De Re or De Dicto. Situation 1, then, appears to be a case in which *a De Se reading does not entail a De Re one*. A minimal contrast is provided by Situation 2, which is supposed to control for any bias there might be in the choice of the examples. As soon as Anna Smith is allowed to stand in a reasonable acquaintance relation with Peter Smith, all the examples become acceptable.

Since we now have a situation in which the De Se reading is true, even though the De Re one isn't, we can determine whether 'he' is only read De Re, or whether it is ambiguously De Re or De Se. If we embed 'he' under 'The letter says to Peter Smith that he....', the following predictions hold:

A. If 'he' is unambiguously De Re, the sentence should behave like b.-c. rather than like a.

B. If 'he' can be read De Se, it should be allowed to have the reading that PRO does, and the sentence should be acceptable, just as a. is.

(i d) shows that the second hypothesis is correct. 'He' does indeed appear to have both a De Se and a De Re reading.

One might argue that the use of 'Peter (Smith)' in the embedded clause in (i c) is misleading because it tends to suggest that the proper name was used in Anna Smith's

letter. But whatever bias there is should exist in (ii c) as well. However the latter is clearly more acceptable, so that the deviance of (i c) cannot be blamed on the embedded proper name. Furthermore, no proper name appears in the following examples, and the use of the indexical pronoun 'your' forces the embedded noun phrase to be read De Re rather than De Dicto. But the contrasts still hold [Jon Nissenbaum, p.c.]:

(16) (i) Situation 1: Same as Situation 1, but in addition Peter Smith happens to be your friend.

- a. Ok The note says to your friend to behave
- b. #The note says that your friend should behave

(ii) Situation 2: Same as Situation 2, but in addition Peter Smith happens to be your friend.

- a. Ok The note says to your friend to behave
- b. Ok The note says that your friend should behave

It should be observed that the preceding argument does *not* hinge on the hypothesis that a De Re reading is systematically blocked in situation x or y. In fact a minimal change in the example can sometimes make the De Re construal acceptable, for reasons which I do not understand⁴⁷. But our argument does *not* hinge on a general understanding of the conditions in which a relation between an agent and a *res* is considered 'vivid' enough to yield a De Re reading. Rather, the argument is just that *there exist situations in which a De Re reading is not acceptable, even though a De Se reading is; and in these cases 'he' can behave like PRO, which shows that 'he' can be read De Se*^{48, 49}

III. A Syntactic Argument

5. Ross's Generalization

Finally, as was seen before the study of Ross's Generalization provides a syntactic argument for positing a distinct De Se reading of 'he'. To repeat, the logic of the argument was the following:

i. Ross shows that a particular syntactic operation (reflexivization in the absence of a local binder) affects in the same way 1st and (to some extent) 2nd person pronouns on the one hand, and 3rd person pronouns embedded under an attitude operator on the other hand.

ii. However Ross's effects disappear *when a 3rd person pronoun embedded under an attitude operator is not read De Se*. Call the rule responsible for Ross's facts 'R' (for Ross's Rule of Reflexivization), and consider two possible theories of 'he' (we use the notation introduced in the Overview):

A. Ambiguity Theory: 'he' can be bound either by an element of the matrix clause, or by a coordinate of the embedded context.

(i) Ross's Generalization, on the assumption that 'he' can be read either De Re or De Se

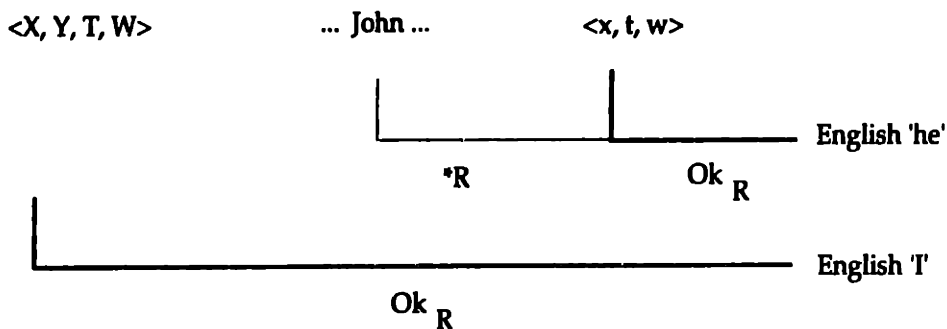

On the Ambiguity Theory it is very to define the class of environments in which Ross's rule is triggered: they are just those cases in which an element (be it 'he' or 'I' or, to some extent, 'you') is bound by a coordinate of a context (matrix or embedded). When 'he' under an attitude operator is read De Re, it is *not* bound by a coordinate of an embedded context, but rather by an element of the matrix sentence, and thus Ross's rule cannot apply.

B. De Re only Theory: 'he' can never be bound by a coordinate of an embedded context. The possible binding relations are now the following:

(ii) Ross's generalization, on the assumption that 'he' can only be read De Re.

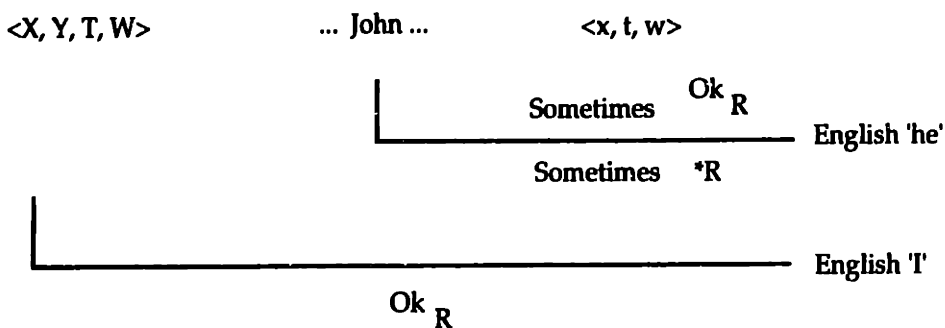

On the 'De Re only' theory the statement of Ross's generalization is rather cumbersome: R may or may not apply when 'he' is bound by 'John', but the precise conditions are now entirely obscure. This was not the case on the Ambiguity Theory, which should thus be preferred.

Guide to the Formal System

In the remaining chapters of this part we will start stating our theory in a relatively explicit formal system. The notation is designed to capture several types of information at the same time, which has the advantage of shortening the presentation, but might also make it occasionally hard to follow. This guide is designed to facilitate the reader's task. Instead of introducing the system piecemeal, we try to give a synthetic presentation, to which the reader might want to go back as he/she reads the coming chapters.

The derivations we introduce have three properties:

- (i) They are as semantically transparent as possible. We have represented variable binding explicitly, and have introduced λ -operators wherever this is necessary for the interpretation.
- (ii) Still, the derivations are supposed to represent syntactic trees at S-Structure (since we do not consider any cases of movement, be it overt or covert, the trees in question wouldn't look too different at LF and at S-Structure anyway). We concentrate on S-Structure because we wish to represent all the features that are relevant to the morphology. Following standard assumptions in Distributed Morphology, we assume that underspecified lexical items are inserted into syntactic trees after S-Structure on the PF branch of the derivation.
- (iii) Where it matters, underspecified lexical items have also been included, together with their featural content (written as a subscript). While we do not particularly concentrate on the morphology, considerations of morphological elegance should in the end matter quite a bit [for instance we have postulated that Anharic 'I' is ambiguous rather than underspecified for a matrix and an embedded use; and this is probably the wrong move].

Concentrating all three types of information on a single representation might give the superficial impression that the formal system is particularly cumbersome. But the reader should bear in mind that the representations that are standardly given in the semantics literature only have property (i), and ignore matters of feature transmission in the syntax and of feature expression in the morphology, i.e. properties (ii) and (iii).⁵⁰

In order to satisfy both (i) and (ii), we use a system in which variables and constants may bear any number of diacritics, written as superscripts. These diacritics should be thought of as syntactic features, like 'masculine', 'feminine', 'plural', etc. [we will need other features in addition]. For simplicity, however, we assume that *the diacritics are part of the variable itself*, so that two instances of a variable may not count as 'the same' unless they share the same features. This has the advantage of enforcing the principle that *a binder and its bindee always have the same features*. [Nothing of substance hinges on this. However other conventions would involve more notation].

Let us now consider a typical example, in which we concentrate on pronouns [see the representation on the next page]:

- (1) a. Smith hopes that he is elected
 b. $\langle \text{John}^A, \text{Mary}^B, 5:00^T, W^{*W} \rangle \lambda \langle X^A, Y^B, T^T, W^W \rangle$ Smith^B hopes that $\lambda \langle x^A, t^t, w^W \rangle$
 x^A /he_m/ is elected at t^t in w^W

1. The initial prefix $\langle \text{John}^A, \text{Mary}^B, 5:00^T, W^{*W} \rangle$ represents the context of the utterance. An utterance is construed as a relation of predication between the (simplified) character of the sentence, of the form $\lambda C P(C)$, and the context of the utterance, construed as a tuple of constants. Constants may bear any number of diacritics. Thus 'Smith', represented as 'Smith^B', with a diacritic 'm' contributes a presupposition that the denotation of 'Smith^B' is male (the diacritic is in bold because it is not the result of agreement, and thus has to be interpreted). Similarly, 'John' bears the diacritic 'A', which indicates that John is the author of the utterance (more precisely: since it appears in bold, and is thus interpreted, it contributes a presupposition that 'John^A' denotes the author of the utterance).

Note that there is nothing in the present system to force the diacritics A, B, T and W to appear on the coordinates of the context of utterance. And while this is not the unmarked situation, it does happen in Free Indirect Discourse that the context of utterance does not bear these features, with the consequence that (for instance) the utterance can be attributed to somebody else than the actual speaker.

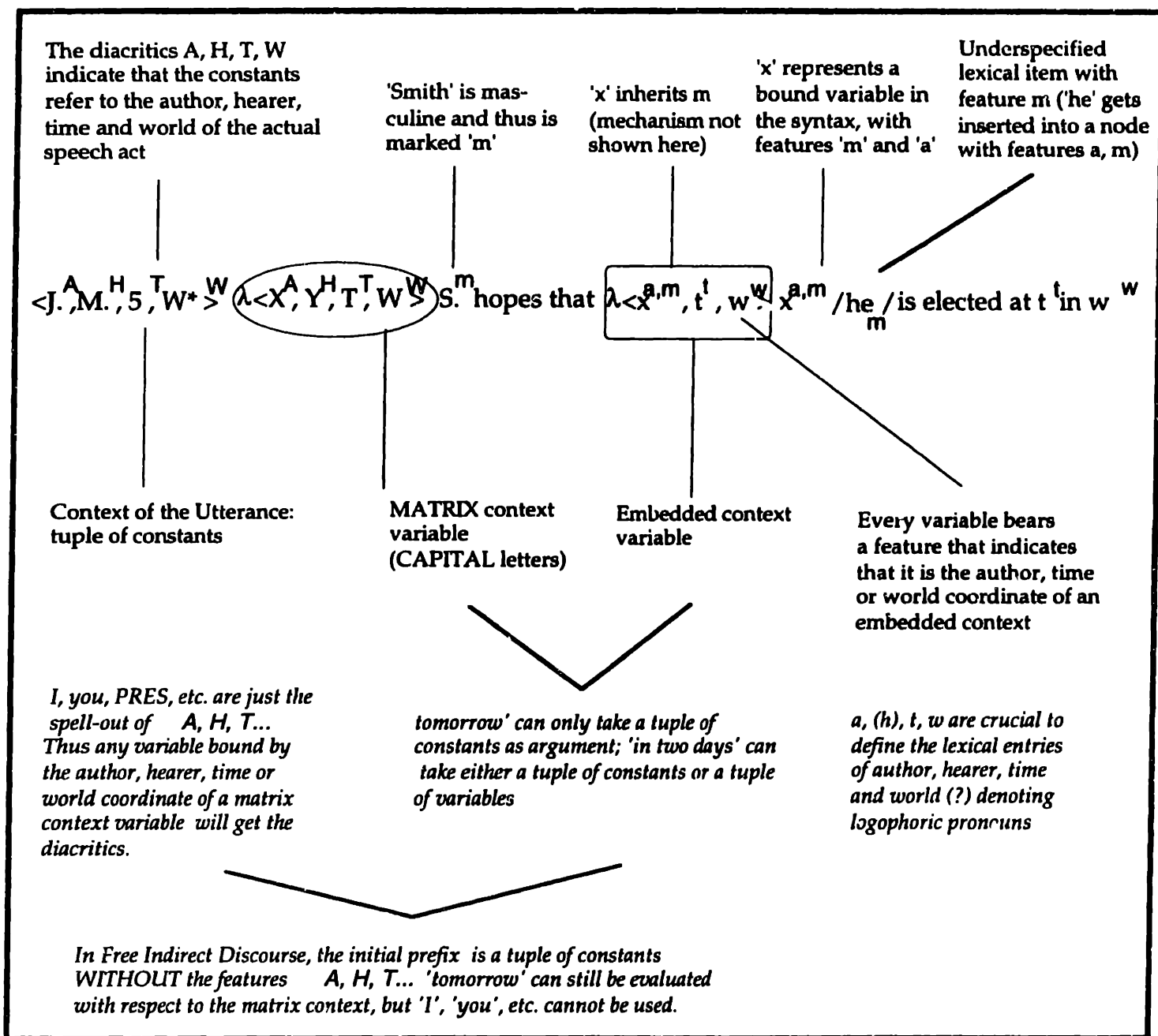

2. The **matrix context variable**, bound by a lambda-abstractor, is represented with CAPITAL letters, to indicate that it is the highest context variable of the sentence. The distinction between matrix and embedded contexts is crucial to formalize the distinction between 'tomorrow' (which can only depend on a matrix context) and 'in two days' (which may either depend on a matrix or on an embedded context).

The coordinates of the matrix context variable inherit the features of the corresponding coordinates of the context of utterance (i.e. the tuple of constants that prefixes the entire sentence): $\langle John^A, Mary^H, 5:00^T, W^{*W} \rangle \lambda \langle X^A, Y^H, T^T, W^W \rangle$.

It is tempting to reduce the difference between matrix and embedded context variables to the distinction between capitalized and non-capitalized. But this won't do: in

Free Indirect Discourse the matrix context bears no capitalized diacritics, but 'tomorrow' can still be evaluated with respect to it. Thus we need to distinguish:

(a) the property of being a matrix context variable (this is encoded by the use of capital letters)

(b) the property of referring to the speaker, hearer etc. of the actual speech act (this is indicated by the diacritics $\overset{\text{A}}$, $\overset{\text{I}}$ etc.).

[The importance of Free Indirect Discourse should be emphasized, as it places non-trivial, and mostly ignored constraints on any semantics for indexicality.]

3. $\langle x^{\overset{\text{A}}{\text{a}}}, t^{\overset{\text{I}}{\text{t}}}, w^{\overset{\text{W}}{\text{w}}} \rangle$ is the embedded context. The variables are not capitalized, since they are not coordinates of the highest context. Two sorts of diacritics appear here:

(i) $\overset{\text{M}}$ is the feature 'masculine', 'inherited' from the matrix subject 'Smith' [the rule of agreement is not given here]

(ii) $\overset{\text{A}}$, $\overset{\text{I}}$ and $\overset{\text{W}}$ (written as superscripts) indicate that the variables are respectively the author, time and world coordinates of an embedded context. The difference between the diacritics $\overset{\text{a}}$, $\overset{\text{t}}$, $\overset{\text{w}}$ and $\overset{\text{A}}$, $\overset{\text{T}}$, $\overset{\text{W}}$ is crucial to capture the contrast between:

(a) the English vs. the Amharic first person pronoun: the latter can bear either $\overset{\text{a}}$ or $\overset{\text{A}}$; the former can only bear $\overset{\text{A}}$.

(b) 'normal' pronouns vs. logophoric pronouns: the latter systematically bear a feature $\overset{\text{a}}$, $\overset{\text{I}}$ or $\overset{\text{W}}$, which forces them to appear on in the scope of an attitude operator, and to have a De Se reading.

CHAPTER 3. PERSON

In this chapter we attempt to account for that part of our cross-categorical generalizations that involves grammatical *person* (tense next chapters). The theory of attitudes and indexicality developed in the preceding chapter will serve as an important auxiliary assumption in the treatment of (1) Sequence Phenomena, (2) Logophoricity, and (3) Free Indirect Discourse. We will end the chapter with a formal treatment of (4) Obviation.

Our account of person will have three main features.

(i) First, we attempt to develop a *Null Theory* of the cross-linguistic differences in the person domain. We claim that the patterns observed cross-linguistically are *not* the result of specific rules (e.g. 'Sequence of Person' rules) that exist in some languages but not in others. Rather, we suggest that the *lexical specifications* of various morphemes can in some cases conspire to yield an apparently homogeneous pattern. This, however, is nothing systematic, and as a result mixed patterns can also be found. Thus in Amharic *both* the 1st and the 2nd person pronouns can be shifted under 'say', while in English none of them can be. But as was observed in Chapter 1, in Aghem and Engenni it is *only the 2nd person pronoun* that can be shifted under an attitude operator; the 1st person pronoun cannot be. While these particular languages have not been studied in detail, the *existence* of such mixed patterns shouldn't be particularly surprising. In fact mixed patterns exist in the domain of temporal adverbials in English, since both the unshiftable indexical 'tomorrow' and the shiftable one 'in two days' are attested. This means that Universal Grammar has the necessary features to establish a lexical distinction between an all-purpose indexical and a matrix indexical. All we suggest, then, is that an analogous distinction should exist in the person domain.

(ii) Still, despite the similarity between temporal adverbials and person, the two must be treated in a slightly different way. There are two empirical reasons for this. First, as was already observed there is in Free Indirect Discourse a difference between adverbs like 'tomorrow', which can be shifted, and indexical pronouns, which cannot. Second, we will see that in some restricted environments a 1st person pronoun can be interpreted as a bound variable; this, however, never happens with 'tomorrow' or 'in two days'.

In order to account for both differences, we assume (1) that an indexical pronoun is not represented as a *function*, but as a *variable*, and (2) that it inherits its features from its binder. In simple cases 'I' is bound by the author coordinate of a matrix context (in English), and inherits its features from that coordinate. These are the cases in which 'I' can simply be interpreted as: 'speaker of the utterance'. But in more complex cases a binder may get 1st person features on purely morphological grounds, and transmit them to the bindee, which can then be spelled-out as 'I' *without denoting the author of the speech act*.

Thus there are cases in which an element which is not bound by the author coordinate of the matrix context still inherits 1st person features. The mirror-image of this is Free Indirect Discourse. There an element which *is* bound by the author coordinate of a matrix context fails to inherit 1st person features, because in Free Indirect Discourse the author coordinate of the matrix context may fail to have the relevant features to begin with.

(iii) Since features are so crucial to our system, we need some specific assumptions about how they get spelled-out. In order to simplify the analysis, we keep the morphological discussion to a minimum. Where precise assumptions matter, we postulate (following standard ideas in Distributed Morphology) that lexical items can be underspecified for one or for several features, and are inserted into fully-inflected syntactic trees in the phonological component. Lexical insertion proceeds according to the Subset Principle, which says in a nutshell that an item *I* can be inserted in a node *just in case I is the most highly specified item compatible with the features of the node*⁵¹.

(iv) The feature system we posit is essentially all we need to handle person. In particular, our system does not by itself raise any issues of locality - and in most cases we will see that there are simply no locality constraints on the readings we consider. This is not to say that there cannot be locality constraints on the elements under study, but only that the constraints have nothing to do with indexicality or propositional attitudes as such. Thus PRO has locality constraints when it is interpreted as a De Se pronoun, but of course the *same* constraints holds in extensional contexts as well, which suggests that they are orthogonal to the system we consider.

I. INDEXICAL PRONOUNS AS BOUND VARIABLES (ENGLISH)

In Heim 1991, examples are presented that show that 'I' is *sometimes* interpreted as a bound variable. Heim's next step is to sketch a system in which 'I' is *always* a bound variable, even when it has its standard indexical interpretation. We develop this intuition within the system introduced in Chapter 2.

1.1. 'I' is sometimes a bound variable

1.1.1. Heim's facts

In general an indexical pronoun cannot be bound - thus 'Every boy knows someone who hates me' cannot mean that every boy knows someone who hates *him*, where 'him' is bound by 'every boy'. However Heim observed that in a small number of environments 'I' can in fact be interpreted as a bound variable. Her key example was the following:

- (1) a. Only I do my homework
- b. [Only I] λx x does my homework
- c. [Only I] λx x does x's homework

The reading in b. is unproblematic, since 'my homework' is interpreted as 'the homework of the speaker'. But this analysis is not possible for c., where the possessive pronoun functions as a bound variable rather than as an indexical pronoun. Hence in c. 'my' does not refer to the speaker - in fact it does not refer at all, since it is a bound variable. This example displays a mismatch between binding and agreement, as illustrated below [we do not explain *why* agreement works in this way - we will end up positing a rule that simply stipulates that it does⁵²]:

- (2) a. Only I do my homework
 b. [only I] λx_i x_i do x_i 's homework

morphological agreement

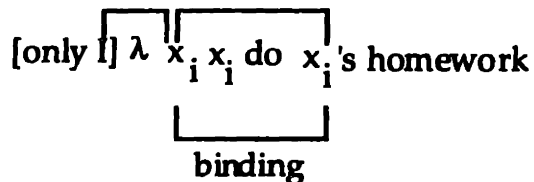

1.1.2. Kratzer's claim⁵³

Kratzer 1998 makes an interesting observation about these examples. She suggests that a 1st person pronoun read as a bound variable must satisfy locality constraints that are not found with 3rd person pronouns. And she further argues that precisely the same type of locality constraints appear to hold for indexical tense. If correct, this would be an interesting discovery from our present perspective, since it would yield a further argument that person and tense should be unified.

Consider Kratzer's examples (her sentences (6) thru (11)):

- (3) (i) Ambiguous: strict and sloppy reading
 a. Only I got a question that I thought I could answer
 b. Only I considered the question whether I should leave before I got bored.
- (ii) Unambiguous: strict reading only
 a. Only I got a question that you thought I could answer
 b. Only I think that Mary won't come if I invite her
- (iii) Ambiguous: non-indexical pronouns
 a. Only this man got a question that you thought he could answer
 b. Only this man thinks that Mary won't come if he invites her

In (ii), Kratzer suggests, the bound variable reading becomes unavailable when another nominal element intervenes between 'only I' and the embedded pronoun. Kratzer claims that the reason for this is that bound first person pronouns start out in a syntactic derivation as 'zero pronouns'. These, she suggests, are elements without features that must inherit their ϕ -features from the closest nominal element. She further argues that zero pronouns are in fact the nominal counterpart of the 'Null tenses' postulated by Ogihara 1996 in his treatment of Sequence of Tense.

While Kratzer's facts are highly suggestive, it is not entirely clear that they are correct. The judgments are subtle⁵⁴. As usual, basic controls must be performed to ensure that the reading which is claimed not to exist is indeed unavailable. First, a context must be chosen that makes the 'unavailable' reading the only sensible one, so that a disambiguation task is in effect transformed into an acceptability task. However when this is done, the bound variable reading in (ii) becomes available:

(4) a. (Among the boys in my family,) only I married a woman that you thought I really loved. (However my marriage just ended up in divorce even though all of my brothers are happily married.)

a'. (Parmi tous les garçons de ma famille), je suis le seul à avoir épousé une femme que tu croyais que j'aimais vraiment. (Pourtant mon mariage s'est fini en divorce, tandis que mes frères ont l'air parfaitement heureux.)

b. (Mary never comes to anybody's parties - and everyone knows this). Only I was vain enough to believe that Mary would come if I invited her.

b'. (Marie ne vient jamais aux soirées de quiconque - et tout le monde le sait) J'étais le seul à être assez sûr de moi pour croire que Marie viendrait si je l'invitais.

Consider a-a'. Given the discourse situation, the property of interest is whether my brothers married women that you thought *they* (not I) loved. And in this context the bound variable reading becomes available (D. Embick, p.c.) Similarly, in b'. vanity is the topic of the conversation. And what shows that I am particularly vain is that the others would never think that Mary would come if *they* (not I) invited her. Again, this is enough to make the bound variable reading available. Looking at other diagnostics for a bound variable reading only confirms the verdict:

(5) a. (Tu sous-estimes toujours les gens.) J'ai eu une question dont tu pensais que je ne pourrais pas la comprendre. Mais après tout Pierre aussi, et Marie également.

b. (Je ne suis pas le seul à présumer de mes forces.) Certes, il y a un an j'ai été assez vaniteux pour penser que Marie viendrait si je l'invitais. Mais après tout Pierre aussi, pas plus tard qu'hier.

A second control is in order. Since the examples in (3 ii) are not disambiguated, we need to make sure that there isn't any bias that favors the uncontroversial reading over the reading claimed to be unavailable. But there does seem to be such a bias. Even in simple cases the bound variable reading is harder to get in the 1st person than in the 3rd person, as shown below (D. Embick, p.c.):

(6) a. (?) Only I like my car (... for instance John doesn't like his)
b. Only Peter likes his car (... for instance John doesn't like his)

(7) a. (?) I like my car and Peter does too (i.e. Peter likes his own car)
b. John likes his car and Peter does too (i.e. Peter likes his own car).

Apparently in both cases the bound variable reading is somewhat harder to get in the 1st than in the 3rd person case. This would explain why there is a contrast between Kratzer's examples in (ii) and those in (iii). [This does not account for the contrast between (i) and (ii), but since our first control showed that sentences analogous to those in (ii) *are* ambiguous after all, it is not clear that there remains any fact to be explained.]

Finally, we will see in Chapter 4 that the temporal part of Kratzer's generalization is also highly questionable - there does not appear to be any argument

for locality constraints in Sequence of Tense cases. To summarize, Kratzer's claims appear to be incorrect, but in a way that preserves her general insight: she is wrong *in the same way for tense and for pronouns*.⁵⁵

1.2. 'I' is always a bound variable

The next step (following the sketch in Heim 1991) is to suggest that 'I' can *always* be treated as a bound variable. The idea is that the author coordinate of the matrix context is (almost) always a possible binder, and that therefore *indexical uses* of 'I' can be analyzed as a special case of bound variable readings [the exception to this is Free Indirect Discourse, where the author coordinate *cannot* bind 'I', for reasons that will become clear later]. Within our system, the natural way to implement this idea is to assume that 'I' spells-out a feature \mathbb{A} (for 'Author') which the variable inherits from its binder. But where did the binder itself get the feature from? We distinguish two cases:

(i) The author coordinate of the tuple of constants that denotes the speech act can have a feature \mathbb{A} , which is interpreted. In these cases we write the feature in **bold** (it is not the case, however, that the author coordinate *must* bear the feature \mathbb{A} - in Free Indirect Discourse this is precisely *not* the case). When it is interpreted, \mathbb{A} forces the constant on which it appears to denote the speaker of the actual speech act.

(ii) In all other cases \mathbb{A} remains uninterpreted. This happens *whenever* \mathbb{A} arises out of *syntactic agreement*. Two cases should be distinguished:

(a) A variable always agree with its binder. If the binder has the \mathbb{A} feature, so does the bindee. But the feature remains uninterpreted.

(b) In addition, there are also situations in which a rule applies to force an element to have the features of another one *which is not its binder* [it is irrelevant for our purposes where the rule is enforced; it could be in the course of a syntactic condition, or it could be at an interface].

Our statement of the condition under which a feature is interpreted is controversial. A rather different theory is suggested for gender features in Heim & Kratzer 1998⁵⁶. There it is assumed that gender features are *always* interpreted. In case a pronoun is not bound, this is unproblematic. In cases of binding, it is suggested that (for instance) the masculine features on the pronoun 'him₁' (with index 1) constrain variable assignments in the following way: "'him₁" cannot denote an inanimate (or non-male) individual *under any assignment*'. It is hard to see how such a proposal could be made to work: Heim's 1st person examples can be replicated with gender features, and there it is clear that a masculine pronoun *does* denote non-male individuals under some assignments:

- (8) a. Only he did his homework (Therefore, his sister didn't do hers)
 b. [Only he] λx x does x's homework

Certainly the possessive 'his' cannot just range over male individuals, for if this were the case the statement wouldn't say anything about individuals in the domain of

discourse that are *not* male. In particular, the inference that ‘his sister didn’t do *her* homework’ would be blocked - an incorrect result⁵⁷.

Once a system is devised for 1st person pronouns, it is easy to extend it to the hearer, time and world coordinates. We introduce the features \mathbb{H} (‘hearer of the actual speech act’), \mathbb{T} (‘time of the actual speech act’) and \mathbb{W} (‘world of the actual speech act’). As usual, lexical items can be specified for any of these features. English ‘I’ can thus receive the specification \mathbb{A} , which indicates that it must inherit its features (directly or indirectly) from an element that refers to the speaker of the actual speech act.

Let us now see how the system works. Consider first a simple case:

(9) a. I think

b. $\langle X^{*\mathbb{A}}, Y^{*\mathbb{H}}, T^{*\mathbb{T}}, W^{*\mathbb{W}} \rangle \lambda \langle X^{\mathbb{A}}, Y^{\mathbb{H}}, T^{\mathbb{T}}, W^{\mathbb{W}} \rangle X^{\mathbb{A}}$ think at $T^{\mathbb{T}}$ in $W^{\mathbb{W}}$

(i) The feature \mathbb{A} on the constant X^* is interpreted as constraining the constant X^* to refer to the speaker of the actual speech act.

(ii) A rule of agreement forces the coordinates of the context variable to agree in features with the coordinates of the context constant:

$\langle X^{*\mathbb{A}}, Y^{*\mathbb{H}}, T^{*\mathbb{T}}, W^{*\mathbb{W}} \rangle \lambda \langle X^{\mathbb{A}}, Y^{\mathbb{H}}, T^{\mathbb{T}}, W^{\mathbb{W}} \rangle \phi$

Since the features on the coordinate of the context variable are the result of agreement, they remain uninterpreted.

(iii) In the morphological component the item ‘I’, specified for the feature \mathbb{A} , is inserted into the node that corresponds to $X^{\mathbb{A}}$. When we wish to give a synthetic notation for both the syntactic structure and the result of competition for insertion in the morphological component, we write the /item/ next to the variable, together with its feature content:

(10) a. I think

b. $\langle X^{*\mathbb{A}}, Y^{*\mathbb{H}}, T^{*\mathbb{T}}, W^{*\mathbb{W}} \rangle \lambda \langle X^{\mathbb{A}}, Y^{\mathbb{H}}, T^{\mathbb{T}}, W^{\mathbb{W}} \rangle X^{\mathbb{A}} /I_{\mathbb{A}}/$ think at $T^{\mathbb{T}}$ in $W^{\mathbb{W}}$

Here $I_{\mathbb{A}}$ represents the (potentially underspecified) lexical entry for the 1st person pronoun. $X^{\mathbb{A}}$ is the variable which gets spelled-out in the morphological component as ‘I’.

Consider now Heim’s example (we consider only the bound variable reading):

(11) a. [Only I] λx x does x’s homework

b. $\langle X^{*\mathbb{A}}, Y^{*\mathbb{H}}, T^{*\mathbb{T}}, W^{*\mathbb{W}} \rangle \lambda \langle X^{\mathbb{A}}, Y^{\mathbb{H}}, T^{\mathbb{T}}, W^{\mathbb{W}} \rangle$ [Only $X^{\mathbb{A}}$] $\lambda y^{\mathbb{A}}$ $y^{\mathbb{A}}$ does $y^{\mathbb{A}}$ ’s homework

(i) The features on $X^{\mathbb{A}}$ have exactly the same origin as in the previous example.

(ii) A rule of agreement forces the variable bound by the λ -operator to bear the feature that appears on $X^{\mathbb{A}}$ in ‘[Only $X^{\mathbb{A}}$]’. The rule is a mere stipulation, but as was observed before, it applies to gender features in exactly the same way as it does to

There is one last detail to attend to. So far nothing in the system forces a symbol to bear a feature. In case a feature is inherited through agreement, special rules already enforce this. But when an interpretable feature appears on a constant, nothing so far prevents the constant from not bearing any feature at all. The following principle blocks this:

- (13) Use features whenever possible!

II. SEQUENCE OF PERSON (ENGLISH VS. AMHARIC)

2.1. English 1st person vs. Amharic 1st person

With this framework in mind, the discussion of the contrast between English and Amharic will be relatively easy. The crucial fact we need to account for is that the English 1st person pronoun may only bear a feature that originates (directly or indirectly) with the author coordinate of the matrix context; by contrast, its Amharic counterpart may *either* get its feature from the matrix *or* from the embedded context.

There are two components to our analysis. First, we must assume that the syntax has features that can distinguish the author coordinate of an embedded context from the author coordinate of a matrix one. We thus assume that the author, hearer, time and world coordinates of an embedded context are endowed with the features \mathfrak{a} , \mathfrak{h} , \mathfrak{t} , and \mathfrak{w} respectively. [Note that these are non-capitalized, and are thus different from the features that appear on the coordinate of a matrix context]. Second, we can use these features to define different lexical entries for the 1st person pronoun in English and in Amharic. The only difference between the two languages will thus have to do with their lexical resources.

At this point we will not attempt to encode formally the fact that the features \mathfrak{A} and \mathfrak{a} (resp. \mathfrak{h} and \mathfrak{H} , \mathfrak{t} and \mathfrak{T} , \mathfrak{w} and \mathfrak{W}) have something in common, since they both appear on elements that denote the author (resp. the hearer, time and word) of a speech/thought act. Ultimately the analysis should probably be done in terms of underspecification, with a further decomposition of \mathfrak{A} and \mathfrak{a} into a feature complex of the form $\mathfrak{A}=[\mathfrak{a}, +\text{matrix}]$ and $\mathfrak{a}=[\mathfrak{a}, -\text{matrix}]$. This would allow the Amharic first person pronoun to have a single, underspecified entry $/I_{\text{Amha}}/$, while the English pronoun would have the entry $/I_{\mathfrak{a}, +\text{matrix}}/$, which is more fully specified (since it contains the features 'a' and '+matrix' rather than just 'a'). The account grounded on underspecification is more desirable than that based on homophony, since it is probably no accident that \mathfrak{A} and \mathfrak{a} should syncretize in the morphology of several languages. On the homophony-based account, this is a complete accident. On the other hand if \mathfrak{a} and \mathfrak{A} are further decomposed, an underspecified item can naturally exist which is specified only for 'a', and can thus be inserted in precisely those environments. We leave this topic for future research, and assume for now homophony rather than underspecification.

a) The system (provisional)

We assume, then, that the coordinates of a context introduced by an attitude verb obligatorily bear certain features. 'John says that ϕ ' will be formalized as:

(14) $\langle X^{\lambda}, Y^{\lambda}, T^{\lambda}, W^{\lambda} \rangle \lambda \langle X^{\lambda}, Y^{\lambda}, T^{\lambda}, W^{\lambda} \rangle$ John says at T^{λ} in W^{λ} that
 $\lambda \langle x^{\lambda}, y^{\lambda}, t^{\lambda}, w^{\lambda} \rangle \phi$

The first line only includes the notation that was introduced in the preceding section. What is new is the second line, which starts with a λ -abstract over a context whose coordinates obligatorily bear the features $\lambda, \lambda, \lambda, \lambda$.

Once this device is established, all we need to do is to assume that the English 1st person pronoun has a single entry /I/ which allows it to be inserted *only in case the variable it spells-out bears the feature λ* , while the Amharic 1st person pronoun may be *either specified for λ or for λ* . For simplicity we assume that the Amharic 1st person pronoun is simply ambiguous between two entries: /I_{Amh λ} / vs. /I_{Amh λ} /.

Consider a provisional implementation of these ideas. In Amharic, the 1st person pronoun may spell-out a variable which is bound either by the author coordinate of a matrix or of an embedded context:

(15) john jägna näNN yt-lall [Amharic]
 John hero I-am says-3 sg.m

a. Matrix reading with 'I_{Amh λ} ': well-formed [the ' λ ' option is chosen]

$\langle X^{\lambda}, Y^{\lambda}, T^{\lambda}, W^{\lambda} \rangle \lambda \langle X^{\lambda}, Y^{\lambda}, T^{\lambda}, W^{\lambda} \rangle$ John says at T^{λ} in W^{λ} that
 $\lambda \langle x^{\lambda}, y^{\lambda}, t^{\lambda}, w^{\lambda} \rangle X^{\lambda} /I_{Amh\lambda}/$ be a hero at t^{λ} in w^{λ}

b. Embedded reading with 'I_{Amh λ} ': well-formed [the ' λ ' option is chosen]

$\langle X^{\lambda}, Y^{\lambda}, T^{\lambda}, W^{\lambda} \rangle \lambda \langle X^{\lambda}, Y^{\lambda}, T^{\lambda}, W^{\lambda} \rangle$ John says at T^{λ} in W^{λ} that
 $\lambda \langle x^{\lambda}, y^{\lambda}, t^{\lambda}, w^{\lambda} \rangle x^{\lambda} /I_{Amh\lambda}/$ be a hero at t^{λ} in w^{λ}

As before, the first line in both examples contains nothing new. But now consider the second line. In a. the embedded pronoun is bound by the author coordinate of the matrix context, and therefore it inherits the feature λ . This allows the item /I_{Amh λ} / to be inserted in the morphological component. In b. the embedded pronoun is bound by the author coordinate of the embedded context, and therefore it bears the feature λ . As a result, the item /I_{Amh λ} / is inserted in the morphological component.

Now consider English. The only difference there is between English and Amharic is that the English 1st person pronoun can only spell-out the feature λ , and never the feature λ . As a result the derivation in b. above is blocked *in the morphological component*:

(16) John says that I am a hero

a. Matrix reading with 'I': well-formed

$\langle X^{*A}, Y^{*B}, T^{*C}, W^{*D} \rangle \lambda \langle X^A, Y^B, T^C, W^D \rangle$ John says at T^C in W^D that
 $\lambda \langle x^A, y^B, t^C, w^D \rangle X^A / I_A /$ be a hero at t^C in w^D

b. Embedded reading with 'I': ill-formed, since 'I' is specified for A

$\langle X^{*A}, Y^{*B}, T^{*C}, W^{*D} \rangle \lambda \langle X^A, Y^B, T^C, W^D \rangle$ John says at T^C in W^D that
 $\lambda \langle x^A, y^B, t^C, w^D \rangle x^A / I_A /$ be a hero at t^C in w^D

The derivation in a. is entirely parallel to its Amharic counterpart. b., on the other hand, is morphologically ill-formed: in the syntax the embedded pronoun is specified only for the feature A. But this entails that the item /I_A/ cannot be inserted, since it is specified for a feature (A) which is not present in the syntax.

It should be noted at this point that there do not appear to be any locality conditions on the dependency of a 1st person pronoun on a matrix or on an embedded context. In English it is clear that the 1st person pronoun may be as deeply embedded as it wants and still depend on the author coordinate of the matrix context. But this also seems to hold in Amharic, as shown by the ambiguity of the example in (15): it is clearly *not* the case that Amharic 'I' can only depend on the closest available context, or else only an embedded reading (=a shifted reading) would be available.

b) The Indexicality / De Se Generalization

Finally, we want to show that the De Se-Indexicality generalization holds in the pronominal case, just as it did in the domain of temporal PPs in English. Consider the following example:

(17) Situation: John, who is a candidate in the election, is so drunk that he doesn't remember who he is. He watches TV and sees a candidate he finds terrific, thinking that this guy must be a hero. This candidate happens to be John himself, though he doesn't realize it.

a. True:	John	səwyew	jägna	näw	alä
	John	the-man	hero	is	said
b. False:	John	əne	Jägna	näNN	alä
	John	I	hero	am	said

[In a normal situation where John has a 'de se' belief, b. becomes true.]

The situation is one in which John has a non-De Se belief about himself - he hopes that the candidate will be elected, without realizing that this candidate is none other than John himself. As predicted, the first-person pronoun is impossible in that context. In case one thinks that this might be because the embedded clause is quoted,

we can correlate wh-extraction with our far-fetched situation to show that the result holds even in cases that are unambiguously in reported speech:

(18) **Situation:** John, who is a candidate in the election, is so drunk that he doesn't remember who he is. He watches TV and sees a candidate, and says: 'He must like X'. This candidate happens to be John himself, though he doesn't realize it. Alemitu didn't hear what the X was.

False: Alemitu assu mən əwäddaläx^w əndalä alsämmaCCəm
 Alemitu he what I-like that-said she-didn't-hear⁵⁹

c) A German version of the Amharic 1st person pronoun

Kratzer 1997 suggested that the inclusive version of the German impersonal pronoun 'man' could be used as a 'De Se pronoun' - in our terms, as a pronoun bound by a coordinate of an embedded context⁶⁰. Her discussion is complicated by the existence of a homophonous form 'man' which, as she argues, is an *exclusive* impersonal pronoun (meaning 'they'). The two can be morphologically distinguished in that exclusive 'man' is defective, and lacks an accusative and a dative forms; while inclusive 'man' becomes 'einen' in the accusative, and 'einem' in the dative. Once these controls are performed, it turns out that inclusive 'man' may refer either to a group that includes the author of the *actual* speech act, or to a group that includes the author of a *reported* speech act. If this is correct, then, *inclusive 'man' is just the 1st person plural inclusive version of the Amharic 1st person pronoun.*

2.2. Agreement and De Se readings

The system outlined in the preceding section is incomplete. As we saw in Chapter 2, 'he' can be semantically dependent on the author coordinate of an embedded context. When this happens the embedded pronoun is read De Se. The natural assumption is that De Se 'he' is just what 'he' normally is, that is, an anaphoric device. But the system developed so far cannot formalize this, for it cannot explain how an element bound by the author coordinate of the embedded context would ever end up with 3rd person features (i.e. with the feature $\mathfrak{3}$). So something more has to be said.

2.2.1. Feature percolation with attitude verbs

Let us consider the problem more closely. As was mentioned in Chapter 2, De Se readings present a mismatch between morphological agreement and binding:

(19) Smith hopes that he will be elected [De Se reading]

Smith hopes that $\lambda \langle x, t, w \rangle$ [x is elected at t in w]

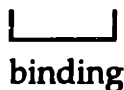
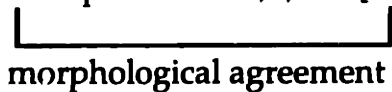

The difficulty is that although the embedded pronoun is bound by the author coordinate of the embedded context, it inherits the features of the matrix subject. Why should that be?

This pattern should be reminiscent of another one - this is in fact precisely the problem we had observed with bound variables readings of 'I' (or for that matter of 'she') under 'only I':

- (20) a. Only I do my homework
 b. [only I] λx_i x_i do x_i 's homework

morphological agreement

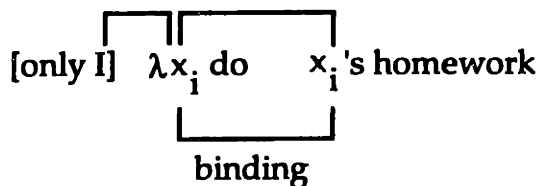

The problem is formally the same in both examples: a pronoun agrees in features with an element which is *inside* the quantifier that binds it. In Heim's example the quantifier is [only I], but the element that triggers agreement is the pronoun embedded inside the brackets. Similarly in the De Se case the quantifier is the entire matrix clause 'Smith hopes (that)' [since attitude operators are just *quantifiers* over contexts], but what triggers agreement is 'Smith', an element embedded inside the quantifier, so to speak.

The solution in the De Se case will be the same as in Heim's example: a stipulation. A rule of feature percolation for De Se cases was stated in Heim 1991. We give a precise mechanism at the end of this section. For present purposes, it is enough to observe that some stipulation can easily be devised that enforces the correct result.

With this provision, the syntax will generate structures such as the following:

- (21) $\langle X^a, Y^b, T^c, W^d \rangle \lambda \langle X^a, Y^b, T^c, W^d \rangle$ John^d says at T^c in W^d that
 $\lambda \langle x^{a,b}, y^b, t^c, w^d \rangle x^{a,b}$ be a hero at t^c in w^d

As can be seen, the author coordinate of the embedded context has now two features: as before, it bears the feature *a*. But in addition it also has a 3rd person feature, which it inherits from the matrix subject 'John'. At this point morphological underspecification becomes crucial: it allows 'he', which is only specified for the feature *d*, to spell-out an element that bears the features *d* and *a* in the syntax. Note that the *same* syntactic element is spelled-out with /I_{Amh}/ in Amharic, and with /he₃/ in English. Both pronouns express the same terminal node, but they choose to express different features of the

2.2.2. 1st person cases within the new system

Before we go any further, we must make sure that the analysis of the Amharic examples provided in the preceding section remains valid with our latest modification of the feature percolation mechanism. The potential problem is that if the Amharic 3rd person pronoun has the same specifications as its English counterpart, i.e. /he_{Amh3}/, it could in principle *also* be inserted to spell-out the embedded pronoun in (19). Consider the case in more detail:

(22) john Jägna näNN yt-lall [Amharic]
John hero I-am says-3 sg.m

b. Embedded reading with /I_{Amh3}/ : well-formed? [the 'a' option is chosen]

$\langle X^{*1}, Y^{*2}, T^{*3}, W^{*4} \rangle \lambda \langle X^1, Y^2, T^3, W^4 \rangle$ John³ says at T³ in W⁴ that
 $\lambda \langle x^{13}, y^1, t^1, w^4 \rangle x^{13}/I_{Amh3}/$ be a hero at t¹ in w⁴

b'. Embedded reading with /he_{Amh3}/: well-formed ?

$\langle X^{*1}, Y^{*2}, T^{*3}, W^{*4} \rangle \lambda \langle X^1, Y^2, T^3, W^4 \rangle$ John³ says at T³ in W⁴ that
 $\lambda \langle x^{13}, y^1, t^1, w^4 \rangle x^{13}/he_{Amh3}/$ be a hero at t¹ in w⁴

The Subset Principle does not decide the issue in this case: both the features of /I_{Amh3}/ and those of /he_{Amh3}/ are a subset of {**1**, **3**}, and furthermore neither item is specified for strictly more⁶¹ features than the other. Nothing is predicted in that case, and morphological theory must resort to 'hierarchies of features', i.e. principles that tell the grammar which feature should be expressed in priority. The Amharic facts are that /I_{Amh3}/ rather than /he_{Amh3}/ must be inserted in that case, which suggests that Universal Grammar finds it more desirable to express **1** than to express **3**. At this point this is a mere stipulation, but later we will see that parallel facts appear to hold in the temporal domain in Russian.

2.2.3. De Se readings

a) 3rd person

We can now give a simple account of De Se vs. De Re readings in the 3rd person case. Agreement in De Re is straightforward, since the embedded pronoun simply agrees with its binder in the matrix clause. In the De Se case, the mechanism of feature percolation used for attitude verbs plays a crucial role and allows the 3rd person feature of the matrix subject to appear on the author coordinate of the embedded context:

(23) John says that he is a hero

a. De Re

$\langle X^{*A}, Y^{*M}, T^{*T}, W^{*W} \rangle \lambda \langle X^A, Y^M, T^T, W^W \rangle$ John^M $\lambda y^M y^M$ says at T^T in W^W that
 $\lambda \langle x^{A,M}, y^M, t^T, w^W \rangle y^M /he_M/$ be a hero at t^T in w^W

b. De Se

$\langle X^{*A}, Y^{*M}, T^{*T}, W^{*W} \rangle \lambda \langle X^A, Y^M, T^T, W^W \rangle$ John^M says at T^T in W^W that
 $\lambda \langle x^{A,M}, y^M, t^T, w^W \rangle x^{A,M} /he_M/$ be a hero at t^T in w^W

b) Other ϕ -features

The agreement mechanism used for 'he' carries over to other ϕ -features as well, as shown in the following. We consider masculine and feminine features⁶², and then 1st and 2nd person matrix pronouns. Since here precise assumptions matter, we make the natural assumption that 'he' is specified for the features M and M ('masculine'), while 'she' is specified for F and f :

(24) a. Smith hopes that he is elected

a'. $\langle X^{*A}, Y^{*M}, T^{*T}, W^{*W} \rangle \lambda \langle X^A, Y^M, T^T, W^W \rangle$ Smith^{M,M} hope at T^T in W^W that $\lambda \langle x^{A,M,M}, t^T, w^W \rangle x^{A,M,M} /he_{M,M}/$ be elected at t^T in w^W

b. Mary hopes that she is elected

b'. $\langle X^{*A}, Y^{*M}, T^{*T}, W^{*W} \rangle \lambda \langle X^A, Y^M, T^T, W^W \rangle$ Mary^{M,f} hope at T^T in W^W that $\lambda \langle x^{A,M,f}, t^T, w^W \rangle x^{A,M,f} /she_{M,f}/$ be elected at t^T in w^W

c. You hope that you are elected

c'. $\langle X^{*A}, Y^{*M}, T^{*T}, W^{*W} \rangle \lambda \langle X^A, Y^M, T^T, W^W \rangle$ Y^M hope at T^T in W^W that $\lambda \langle x^{A,M}, t^T, w^W \rangle x^{A,M} /you_M/$ be elected at t^T in w^W

d. I hope that I am elected

d'. $\langle X^{*A}, Y^{*M}, T^{*T}, W^{*W} \rangle \lambda \langle X^A, Y^M, T^T, W^W \rangle$ X^A hope at T^T in W^W that $\lambda \langle x^{A,A}, t^T, w^W \rangle x^{A,A} /I_A/$ be elected at t^T in w^W

At this point the reader might be puzzled. Doesn't the example in d. display an embedded 1st person pronoun which gets evaluated with respect to the context of the *reported* speech act? And isn't this precisely the pattern that was supposed to hold in Amharic, but crucially not in English? Well, it is indeed correct that in this case English looks surprisingly like Amharic; and furthermore, this is a necessary consequence of the system developed so far: the agreement procedure needed to handle a., b. and c. will mechanically generate d. as well. However it is for entirely different reasons that a 1st person pronoun can be shifted in this particular case in English, and in full generality in Amharic. The crux of the matter in d. is that the matrix subject bears the feature A , which gets passed on to the author coordinate of the embedded context and then to the embedded De Se pronoun; this allows $/I_A/$ to be inserted in the morphological

component. In Amharic, on the other hand, there is a lexical entry /I_{Amh}/, specified for the feature a; as a consequence, independently of any issue of agreement a variable bound by the author coordinate of an embedded context can always be spelled-out as a 1st person pronoun.

The same agreement mechanism also accounts for the appearance of a plural pronoun in the embedded clause even if the thought which is reported was in the singular:

- (25) a. Smith and Jones (each) hope: 'I will be elected'
 => Smith and Jones (each) hope that THEY will be elected
 b. $\langle X^A, Y^B, T^C, W^D \rangle \lambda \langle X^A, Y^B, T^C, W^D \rangle$ [Smith and Jones]^B hope that $\lambda \langle x^A, t^C, w^D \rangle x^A, t^C$ /they_{pl}/ be elected at t^C in w^D

The system also predicts that number features should percolate to the subject of the embedded clause in Amharic. This appears to be correct:

- (26) Situation: John said: 'I like X', and Peter said: 'I like Y'. I want to know what X and Y are.

a. mIn Inwəddallən alu
what we-love they-said
 'What did they say they like?'

b. *mIn Iwəddalləku (Iwəddalləku) alu
what I-love (I-love) they-said

Even though the claims that are reported were in the 1st person singular, they have to be reported in the 1st person plural. Abstracting from wh-extraction (which is needed to insure that the embedded clause is not quoted, as in b.), the derivation is exactly the same as for the aforementioned English sentence:

- (27) lit. $\langle X^A, Y^B, T^C, W^D \rangle \lambda \langle X^A, Y^B, T^C, W^D \rangle$ [They]^B said that
 $\lambda \langle x^A, t^C, w^D \rangle x^A, t^C$ /we_{Amh pl}/ be elected at t^C in w^D

If the Amharic 1st person plural ending can have the entry: we_{Amh pl}, its features are clearly compatible with those that appear in the subject position of the embedded clause, and hence (since no other item is specified for more features) it must be inserted.

c) Locality

It should be noted that nothing in the system predicts any locality constraints on De Se readings. It could be that some element is lexically specified as having certain locality conditions. In fact this appears to be the case of PRO. But there is nothing in the system to force this.

First, we observe that the feature passing mechanism used for De Se readings does not require that the element whose features are copied be syntactically

represented in the same sentence, at least not on the surface. Consider for instance the following:

- (27) a. <Talking about the murderer> The desire PRO to be recognized for the genius he really was was too overwhelming. <John turned himself in.>
a'. Le désir d'être reconnu pour ce qu'il était, un génie du crime, était trop fort. <Jean se dénonça>.
b. <John Smith, a former candidate, looks back> In retrospect, the hope that he would be elected was utterly groundless.
b'. L'espoir qu'il serait élu avait été, en définitive, sans le moindre fondement.

In these examples it is enough for it to be *understood* that the agent of the desire/hope is male for the correct ϕ -features to be transmitted to PRO or De Se 'he' in the embedded clause (as usual, proving that 'he' is De Se rather than De Re would be difficult). Accordingly, the rule of feature transmission for attitude operators should not be stated in terms that refer to the overt syntax, since this would make the foregoing cases particularly problematic. [We will see in Chapter 4 that exactly the same facts hold of Tense agreement in attitude environments: no overt tense need appear to trigger tense agreement. Rather, it is enough that it be understood that the speech- or thought-act occurred in the past to force tense agreement].

Second, there do not appear to be any locality conditions on De Se readings. In fact it has been known since Castañeda's work that De Se 'he' (what he called 'he*') can be very long-distance indeed. He gave the following examples [Castañeda 1968], in which 'he (himself)' is a pronoun read De Se:

- (28) a. The Editor of *Soul* knows that he (himself) is a millionaire.
b. The Editor of *Soul* knows that Mary knows that her niece knows that he (himself) is a millionaire.

a. is a simple case of De Se, while b. is a long-distance version. As Castañeda notes, what the Editor of *Soul* would assert is:

- (29) a. 'I am a millionaire'
b. 'Mary knows that her niece knows that I am a millionaire'

As usual, an indexical ('I') in direct discourse corresponds to a De Se pronoun in reported speech. Within our system (28b) is formalized as follows (for simplicity I replace 'her niece' with 'Ann'. And I omit the usual context prefix at the beginning of the matrix clause, and leave out diacritics):

- (30) The Editor of *Soul* knows that
 $\lambda\langle x, t, w \rangle$ Mary knows that
 $\lambda\langle x', t', w' \rangle$ Ann knows that
 $\lambda\langle x'', t'', w'' \rangle$ x is a millionaire.

Note, on the other hand, that there *do* exist locality conditions on PRO. But they have nothing to do with the De Se issue *per se*, since the same conditions exist even when PRO appears in an extensional context (e.g. with 'force'). In fact the fact that PRO is unambiguously read De Se should presumably be derived from its locality conditions.

Since the author coordinate is always a possible antecedent for PRO, and since it is closer than other potential antecedents, it presumably blocks binding of PRO by a higher element. We leave this topic for future research.

2.3. Implementation

The implementation of the system outlined so far is relatively unproblematic. Here is a statement of the main principles:

(31) Features [disregarding gender features]

- a. $\lambda, \mu, \tau, \omega$ [as before]
- b. \exists [as before]
- c. a, b, t, w [new]

Note: a, b, t, w are never interpreted

(32) Lexical Entries [disregarding gender features]

- a. I_λ
- b. you_μ
- c. he_τ
- d. $I_{Amh\lambda}$
- e. $I_{Amh\mu}$
- f. $he_{Amh\tau}$

(33) Attitude Operators

Replace the formation rule for attitude operators with:

If ϕ is a well-formed formula and if ATT is an attitude operator,

$ATT(x^\lambda, (y^\mu), t^\tau, w^\omega) \lambda \langle x^\lambda, (y^\mu), t^\tau, w^\omega \rangle \phi$ is a well-formed formula.

[where $\lambda, \mu, \tau, \omega$ stand for the set of all features that appear on $x, y, t,$ and w respectively]

III. LOGOPHORICITY

The feature system we have introduced gives us a straightforward way to account for Logophoricity. As was pointed out in Chapter 1, some West African languages have a pronoun which can only occur in indirect discourse, and systematically denotes the author of a *reported* speech act. Why should that be? Simply because these pronouns are lexically specified for the feature λ . This is the formal counterpart in our system of a suggestion made in Chierchia 1988: logophoric pronouns are De Se pronouns.

Before we get into technicalities, it should be noted that Castañeda 1966 had already postulated the existence of a separate pronoun 'he*', used to attribute self-knowledge to others. 'he*' was supposed to correspond in indirect discourse to the 1st person pronoun of a direct discourse. In terms of more recent philosophical and linguistic discussions, 'he*' is just a pronoun which is unambiguously De Se. In terms of comparative linguistics, he* is a logophoric pronoun. Apparently Castañeda had already hinted at the existence of a separate form for he* in Ancient Greek. And Chierchia suggested that English PRO, and Italian 'proprio', had specific De Se uses. This line of research was further explored by Kusumoto 1998, who (partly following Kuno) extended these ideas to Japanese 'zibun', and sought to argue for the existence of logophoric uses of tense. However none of these elements are exclusively De Se (except, maybe, Ancient Greek indirect reflexives). Similarly, Kratzer 1997 suggested that the inclusive version of the German impersonal pronoun 'man' had logophoric uses, but as was said earlier the 'man' is really an inclusive plural counterpart of the Amharic 1st person pronoun, which may either depend on a matrix or on an embedded context.

Thus none of these cases are pure examples of Castañeda's he*, which by definition occurs *only* in attitude environments, and is thus a pure De Se pronoun. By contrast, logophoric pronouns in the original sense (i.e. pronouns that are used only to 'carry discourse', i.e. to report somebody's thoughts or words) are pure cases of he*. As was mentioned in Chapter 1, the logophoric pronouns that are found in a number of West African languages are 'used exclusively to designate the individual (...) whose speech, thoughts, feelings, or general state of consciousness are reported or reflected in the linguistic context in which the pronoun occurs' [Clements on Ewe, 1975 p. 141]⁶³. Summarizing cross-linguistic data, Clements characterized logophoric pronouns as elements that satisfy conditions (i)-(iii) [Clements 1975 p. 171]:

"(i) logophoric pronouns are restricted to *reportive contexts* transmitting the words or thought of an individual or individuals other than the speaker or narrator";

(ii) the antecedent does not occur in the same reportive context as the logophoric pronoun;

(iii) the antecedent designates the individual or individuals whose words or thoughts are transmitted in the reportive context in which the logophoric pronoun occurs."⁶⁴

The idea we pursue is that all three properties follow if the logophoric pronoun in Ewe is lexically specified as being bound by the author coordinate of an embedded context:

(i) it can only occur in reportive contexts because these are the only environments in which there is an embedded context in the first place;

(ii) its 'antecedent' (i.e. the element it 'corefers with', in intuitive terms) must be the agent of the thought or speech act which is reported, and therefore it must occur as an argument of the attitude verb which introduces the embedded context, and not in the embedded clause itself;

(iii) since the pronoun is bound by the author coordinate of an embedded context, it necessarily reports somebody's words or thoughts.

3.1. Author-denoting logophoric pronouns

First, let us observe that our analysis of Amharic 'I' already relied on a lexical entry used exclusively in case a variable was bound by the author coordinate of an embedded context:

- (34) a. I_{Amhl}
 b. I_{Amha}

For better or worse, the entry in b. can only be used to spell-out an author-denoting De Se pronoun. This solution was not particularly elegant for Amharic, since it was based on homophony rather than underspecification, even though the two uses of Amharic 'I' would rather seem to have a lot in common. Still, there is little doubt that entries of precisely this form are available to Universal Grammar, since there are morphological forms which, unlike the Amharic 1st person pronoun, can *only* appear if they are bound by a coordinate of an embedded context.

As was shown in Chapter 1, in Ewe and Gokana logophoric markers appear to be author-denoting. This suggests that the following entries should be posited⁶⁵:

- (35) a. Ewe: yè₁
 b. Gokana: LOG₁

From these entries the two major properties of Ewe-style logophoric pronouns can be derived:

- (i) Logophoric pronouns can only appear in attitude environments, since only attitude operators can introduce a feature *a*.
- (ii) Since only an author coordinate can bear *a*, these elements must be author-denoting.

The formalization is straightforward. Clements's first example is analyzed as in b. [for simplicity, I disregard tense]:

- (36) a. kofi be yè-dzo [=Clements's (1)]
 Kofi say LOG-leave
 'Kofi said that he (Kofi) left'

b. $\langle X^a, Y^a, T^a, W^a \rangle \lambda \langle X^a, Y^a, T^a, W^a \rangle$ Kofi^a said at T^a in W^a that $\lambda \langle x^a, t^a, w^a \rangle$
 x^a /yè₁/be elected at t^a in w^a

(iii) There is a further relevant fact, which is of some interest in connection with our analysis. In both Ewe and Gokana, a plural pronoun may be logophoric *even if only one of the individuals denoted is the author of the reported speech act*:

(37) Ewe: logophoric equivalent of 'we'

kofi kpo be yèwo-do go
Kofi see that LOG-come out
[Clements's (24)]

'Kofi_i saw that they_{i+k} had come out'

'Direct discourse': 'We have come out' (presumably)

(37') Gokana: logophoric equivalent of 'we'

a. lébàrè kɔ baè dɔ-è
Lebare said they fell-LOG [H & C's (38b)]
'Lebare_i said that they_{i+k} fell'

b. lébàrè kɔ baè dɔ
Lebare said they fell [H & C's (38a)]
'Lebare_i said that they_{i+k} fell'
'Lebare_i said that they_i fell'

Direct discourse : 'We fell' (presumably)

In other words, a logophoric feature [or rather, an **ã** feature] can appear not just in case an element is bound by the author coordinate of the embedded context, but also when somehow the value of a pronoun includes the author of the reported speech act. Is this something that has to be stipulated, or can it be derived?

As a matter of fact this is a phenomenon that we already know from garden-variety indexical pronouns. In English, a pronoun that refers to the speaker and somebody else is spelled-out as 'we', not 'they'. And in Chinese, it is pronounced as 'wo³men', i.e. as the concatenation of the 1st person pronoun [=wo³] and the plural marker [=men]. So this certainly suggests that the 1st person plural pronoun has, among others, a 1st person feature. And, just as the feature **ã** gets overtly spelled-out as 'wo³' in Chinese, so the feature **ã** is systematically spelled-out as a logophoric agreement marker in Gokana.

[Kratzer 1997 makes a related point with respect to inclusive 'man' in German. She observes that it can be plural, but must always include the speaker of the actual or of the reported speech act. She proposes a semantic decomposition into two parts: one element, MAN, denotes the speaker of a context; while the other, IN (an inclusive marker) denotes a function which associates to an individual a 'the group of a'⁶⁶]

Thus on morphological and semantic grounds, a very simple theory of plural indexical pronouns suggests itself: 'we' is analyzed semantically as 'I + he' (exclusive 'we') or 'I + you' (inclusive 'we'); and morphologically the features of *both* members of the (semantic) conjunct appear on the plural pronoun. This yields the following system, already hinted at in Landau 1999:

(1) English: 'we' has the lexical entry /we_{1, n}/, while 'you', which is underspecified for number, is just /you_n/. Here is an illustration:

(38) a. We (= I + you) think
 b. $\langle X^{*1}, Y^{*2}, T^{*3}, W^{*n} \rangle \lambda \langle X^1, Y^2, T^3, W^n \rangle$
 $[X^1 \& Y^2]^{1,2} /we_{1, n} /$ think at T^3 in W^n

(39) a. We (= I + he) think
 b. $\langle X^{*1}, Y^{*2}, T^{*3}, W^{*n} \rangle \lambda \langle X^1, Y^2, T^3, W^n \rangle$
 $[X^1 \& x^2]^{1,2} /we_{1, n} /$ think at T^3 in W^n

(2) In languages that distinguish 1st person inclusive from 1st person exclusive pronouns, the following entries can be posited:

/we-incl_{1, 2, (n)}/

/we-excl_{1, 3, (n)}/

(3) In Ewe and Gokana, the logophoric pronoun/agreement marker is simply specified for **1**. Disregarding tense, the plural example considered above becomes:

(40) a. lébàrè kɔ baè dɔ-è
 Lebare said they fell-LOG [H & C's (38b)]

b. $\langle X^{*1}, Y^{*2}, T^{*3}, W^{*n} \rangle \lambda \langle X^1, Y^2, T^3, W^n \rangle$ Lebare¹ says in W^n that
 $\lambda \langle x^1, y^2, t^3, w^n \rangle [x^1 \& x^2]^{1,2} /LOG_1 /$ fell in w^n

This derives a puzzling asymmetry noted by Hyman & Comrie. Although a plural logophoric pronoun can (optionally) 'be used to indicate that a third person trigger [i.e. a third person matrix antecedent] is *properly included* in a third person target [i.e. a third person embedded element - PS]', 'the LOG suffix is not grammatical when it is the target which is properly included in the trigger' (p. 32):

(41) Gokana: logophoric equivalent of 'we'

a. *baè kɔ aè dɔ-è
 they said he fell-LOG [H & C's (39b)]

b. baè kɔ aè dɔ
 they said he fell-LOG [H & C's (39b)]
 'They_{i+k} said that he_{i+k} fe!'
 'They_i said that he_j fell'

Direct discourse: presumably, they said: 'He fell'

On the present approach there is no particular reason for logophoric marking to appear in a., since the discourse which is reported was of the form 'He fell' rather than 'I fell' or

'we fell'. As a consequence, the embedded pronoun does not bear any μ features, so that the logophoric agreement marker cannot be inserted.

The decompositional analysis of plural indexical pronouns has other desirable consequences⁶⁷:

I. The system predicts that the 'he' part of 'we' could be bound by a quantifier, even though the 'I' part is not. This is indeed the case, as shown by the following examples [c. is due to B. Partee]:

- (42) a. Most of my relatives are so annoying that we end up having an argument
a'. [Most of my relatives] λx [x is so neurotic that [I + x] end up having an argument
b. (Said by a man who was married many times) Most of my wives were so neurotic that we would have fights all the time.
c. John often comes over for Sunday brunch. Whenever someone else comes over too, we (all) end up playing trios. (Otherwise we play duets) [Partee 1991; her (15)]

As shown in a', the 'he' part of 'I + he' can be bound by the generalized quantifier 'most of my relatives'.

II. As was observed earlier, PRO in an attitude context can only be read De Se, and behaves in this respect like a logophoric pronoun. However unlike logophoric pronouns, PRO always needs a local antecedent when it appears in a complement clause. But there is an interesting twist to this. As shown in Landau 1999, there are in (some) attitude contexts cases of partial control, in which the embedded infinitive is interpreted as having as subject a (semantically) plural entity, one member of which is coindexed with the controller. Furthermore, there are locality conditions only on the controlled part of the plural subject. The natural assumption, then, is that in these cases the embedded subject is in fact 'PRO + he', with the standard locality conditions for PRO, and no locality conditions at all for the 3rd person pronoun.

(iv) Are logophoric pronouns unambiguously De Se ?

We come to the crucial semantic test: are logophoric pronouns unambiguously De Se? The prediction is of course that this should be their only reading. Unfortunately we have no data concerning De Se in Ewe and Gokana. Kusumoto gives data for Japanese (where 'zibun' is not a true logophoric pronoun, but does seem to have logophoric uses), and Bafut, a language we know nothing about. Here are her data - her claim is of course that these elements are indeed unambiguously De Se:

(43) Kusumoto 1998 (her example (15))

Situation (Kaplan 1977): John is looking at a mirror from a distance and sees a man in the mirror. He notices that the man's pants are on fire. In fact, the man he sees in the mirror is John himself, but he doesn't realize it.

a. John believes that his pants are on fire

b. John-wa ?*zibun-no/kare-no pantu-ni hi-ga tuiteiru to omoteiru
John-top self-gen /he-gen pant-on fire-nom set-pres comp think-pres

'John thinks that his pants are on fire' [Kusumoto's judgment; confirmed by Miyagawa, p.c.]

c. John wà?àtð mð *yu/à ká khi (Bafut; P.Tamanji,p.c to Kusumoto)

John thinks that self/he FUT burn

'John thinks that he is going to get burnt'

Finally, we note that the system we have been using to account for Logophoricity does not predict any locality constraints on the distribution of logophoric pronouns (except, of course, for the obvious fact that they have to be in the scope of an attitude operator). Earlier we observed (following Castañeda) that there are no locality constraints on De Se readings in English. What we now claim is that there are no locality conditions on the *morphological reflex* of a De Se reading. Again, there *could* be cases in which some logophoric element is lexically specified as having some locality constraints, but our contention is that there is no intrinsic connection between De Se/Logophoricity and Locality. And this appears to be correct. Clements made the following observation (Clements 1975 p. 173):

"That the intervention constraint (...) plays no strict role in Ewe is demonstrated by examples such as the following, in which a possible antecedent intervenes between 'yè' and its true antecedent (in reading (a)):

(44) kofi xɔ-e se be ama gblɔ be yè-fu-i
Kofi receive-pro hear comp ama say comp LOG-beat-pro

a. 'Kofi believed that Ama said that he_j beat her'

b. 'Kofi believed that Ama_j said that she_j beat him' [Clements's (73)]

Both readings appear to be equally salient for the speakers consulted.' Thus Ewe logophoric pronouns can be bound by an element which is two clauses up, and no intervention effects seem to exist. Similar facts appear to hold in Gokana.⁶⁸

3.2. Hearer-denoting logophoric pronouns

Since contexts have a hearer as well as a speaker coordinate, there should in principle exist hearer-denoting logophoric pronouns, i.e. pronouns used only in reported speech to denote whoever would in direct discourse be referred to as 'you'. There appear to be such pronouns in Mapun, a Chadic language described by Frayzingier. There are three categories of pronouns in Mapun, which he calls sets A, B and C. He describes their uses as follows:

(45) 'In logophoric environments, set B pronouns indicate coreferentiality with the subject, set C pronouns indicate coreferentiality with the addressee when they share with it the features of gender and number. Set C pronouns may also refer to the addressee who is not overtly marked in the main clause, when the embedded clause is in either the imperative or the prohibitive mood. In other environments, set C pronouns indicate disjoint reference. Set A pronouns always indicate disjoint reference with either subject or addressee'. [Frayzingier 1985 p. 31]

It is clear from Frayzingier's description that B-pronouns are not purely logophoric, but rather have logophoric uses in which they can only refer to the speaker coordinate of an embedded context. For our purposes it is enough to see that some feature or combination of features has to single out the hearer coordinate of an embedded context. This shows that contexts should include a hearer coordinate, which of course is a natural assumption since matrix contexts certainly do have such a coordinate^{69,70}.

IV. FREE INDIRECT DISCOURSE

The present system has a rather surprising property. Although all the examples we have analyzed so far started with the prefix $\langle X^{*A}, Y^{*B}, T^{*T}, W^{*W} \rangle$, there is nothing in the theory that forces the matrix context to bear the diacritics A, B, T, and W. Since A, B, T, and W encode the fact that the constants X^* , Y^* , T^* and W^* refer to the speaker, hearer, time and world of utterance of the actual speech act, this entails that there is nothing in the system to force the matrix context to be the context of the actual speech act. What would be a sentence that did not satisfy this condition?

Suppose the matrix context is $\langle \text{John, Mary, 1960, actual world} \rangle$. The context of the *actual* speech act is clearly different, since *I* am writing what follows, and *you* are reading it. Since John and Mary are neither the speaker nor the hearer of the actual speech act, the constants that refer to them ('J' and 'M') should not bear the diacritics 'A' or 'B'. And, since 1960 is in *our* past, the constant T should bear a diacritic that encodes this, say, *Past*. The result, then, will be an utterance that starts with:

(46) $\langle J^i, M^j, 1960^{Past}, W^{*W} \rangle \lambda \langle X^i, Y^j, T^{Past}, W^{*W} \rangle \dots$

How should the sentence that follows the prefix look like?

(i) *Morphologically*, every pronoun bound by J should be in the 3rd person masculine, every pronoun bound by M should be in the 3rd person feminine. 'I' and 'you' should not be used to refer to John and Mary, since J and M lack the features 'A' or 'B'. [We will see later that, similarly, any temporal pronoun bound by the time coordinate of the matrix context must in this case inherit the feature *Past*.]

(ii) *Matrix indexicals* like 'tomorrow' or 'today' should be interpreted with respect to the matrix context $\lambda \langle X, Y, T^T, W^W \rangle$. This is because we had originally stipulated that such elements are function symbols that take matrix context variables (i.e. capitalized symbols) as arguments. The lexical entry we had posited was [(43 b), Chapter 2]:

(47) '(the day after tomorrow)' is a function symbol that can only take as a matrix context variable as argument, i.e. the day after tomorrow(C) is well-formed, but the day after tomorrow(c) is not. When it is syntactically well-formed, its value given an assignment s is:

$$[[\text{the day after tomorrow}(C)]] = [[\text{time}(C)]] + 2$$

Since $\langle X^i, Y^j, T^{\text{ind}}, W^{\text{pl}} \rangle$ is clearly a matrix context, 'the day after tomorrow' can (and in fact must) be evaluated with respect to it.

(iii) *Semantically*, the entire sentence should be interpreted as an utterance made by John to Mary. In other words, it should be interpreted essentially like a direct discourse that took place in 1960, with John as the actual speaker and Mary as the actual speaker. This has several consequences:

a. There should be no De Dicto-De Re distinction, for the simple reason that there is no attitude operator at all.

b. Since one doesn't normally use one's own name to refer to oneself in direct discourse, it should sound odd to use 'John' in such sentences. For similar reasons, 'she' rather than 'Mary' should be used to refer to Mary in such a sentence.

As the reader will have guessed, this surprising type of sentences is instantiated in 'Free Indirect Discourse' ('Discourse Indirect Libre' in French, 'Erlebte Rede' in German; Banfield uses the term 'Represented Speech and Thought' in English, but I will stick to the literal translation of the French term). The phenomenon was studied from a linguistic perspective by Reinhart 1975 and Banfield 1982 and Doron 1991. I follow Banfield's discussion in her Chapter 2 ('The sentence of represented speech and thought').

Consider again these examples, which were mentioned in Chapter 1:

(48) a. Jean parlait à Marie, avec passion. Oui, vraiment, il l'aimait, et demain
Jean was-talking to Marie, with passion. Yes, really, he loved her, and tomorrow
 il l'épouserait. (Rien de tout cela n'était vrai)
he would marry her. (None of all this was true)

b. #Jean parlait à Marie, avec passion. Oui, vraiment, je t'aimais, et demain
Jean was-talking to Marie, with passion. Yes, really, he loved her, and tomorrow
 je t'épouserais.
I would marry you

c. #Jean parlait à Marie, avec passion. Oui, vraiment, il l'aime, et demain
Jean was-talking to Marie, with passion. Yes, really, he loves her, and tomorrow
 il l'épousera.
he will marry her

d. <Jean parlait à Marie, avec passion. Il disait:> 'Oui, vraiment, je t'aime, et
Jean was-talking to Marie, with passion. He said: 'Yes, really, I love you, and
 demain je t'épouserai'. (Rien de tout cela n'était vrai).
tomorrow I will marry you'. (None of all this was true).

e. Jean parlait à Marie, avec passion. Il disait qu'il l'aimait, et que
Jean was talking to Marie, with passion. He said that he loved her, and that

le lendemain/ *demain il l'épouserait
*the day after / *tomorrow he would marry her.*

d. is in direct discourse; 'tomorrow' can be used, but 'I' and 'you' rather than 'he' and 'she' must be used to refer to Jean and Marie. e. is in indirect discourse - 'he' and 'she' can be used to refer to Jean and Marie, but then the matrix indexical 'tomorrow' cannot be shifted. a. is the surprising combination that defines Free Indirect Discourse:

(i) 'He' and 'she' are used to refer to Jean and Marie

(ii) 'tomorrow' is shifted, i.e. it is evaluated with respect to the time of Jean's speech act.

(iii) To see that the entire sentence (with the exception of temporal and pronominal elements!) is interpreted as an utterance made by John to Mary, note that the actual speaker (me, not John) does not have to believe a word of what is said in the sentence. Thus a. is not a contradiction:

(49) a. Jean parlait à Marie, avec passion. Oui, vraiment, hier il lui avait sauvé la vie, et demain, il l'épouserait! Une semaine plus tard, il ne s'était toujours rien passé.

'Jean was talking to Marie with passion. Yes, really, yesterday he had saved her life, and tomorrow he would marry her! A week later, nothing had happened'

b. #Jean parlait à Marie, avec passion. La veille il lui avait sauvé la vie. Et le lendemain il l'épousa. Une semaine plus tard, il ne s'était toujours rien passé.

'#Jean was talking to Marie with passion. The day before he had saved her life, and a day later he married her. A week later, nothing had happened'

b., on the other hand, is contradictory: if Jean married his interlocutor two days after their discussion, then of course one week later *something* had happened - the wedding had taken place! But a. is coherent. The second sentence in a. can only be interpreted as a Free Indirect Discourse, since 'après-demain' cooccurs with a future-in-the-past. As a consequence, the sentence is not construed as an utterance by the actual speaker (me) to the actual hearer (you), but rather as what Jean said to Marie. And the fact that he said he would marry her certainly does not entail that he in fact did.

This also derives a puzzling fact about Free Indirect Discourse: proper names cannot be used to refer to the purported author (or hearer) of the utterance / thought act (hence the deviance of c'. in the preceding example). As Reinhart observed, this can be reduced to a constraint on direct discourse, since there the speaker cannot normally refer to himself using his own name. Thus c'. can and must be treated on a par with a':

(50)

a'. #J. parlait à M., avec passion. Il dit: 'Oui, vraiment, hier Jean a sauvé Marie!'

#'Yes, really, yesterday Jean saved Marie!'

c'. (Jean parlait à Marie, avec passion.) #Oui, vraiment, hier Jean avait sauvé Marie!

#Yes, really, yesterday Jean had saved Marie!

Let us see more precisely how the formal system handles these examples. A quotation is treated as a simple utterance; indirect discourse works as stated above; and free indirect discourse is a direct utterance, but with no λ , \mathbb{M} or \mathbb{T} diacritics in the matrix context [I have assumed that there was still a \mathbb{W} diacritic on the world coordinate; it is not clear that this is the right move - after all these are cases of *fiction*]. For simplicity, I omit some of the time and world variables:

(51) (i) Direct Discourse

a. 'Oui, vraiment, je t'aime, et demain...'

Yes, really, I love you, and tomorrow...

b. $\langle J^{\lambda}, M^{\mathbb{M}}, 1960^{\mathbb{T}}, W^{*\mathbb{W}} \rangle \lambda \langle X^{\lambda}, Y^{\mathbb{M}}, T^{\mathbb{T}}, W^{\mathbb{W}} \rangle$ Yes, really, X^{λ} love $Y^{\mathbb{M}}$... and tomorrow($\langle X^{\lambda}, Y^{\mathbb{M}}, T^{\mathbb{T}}, W^{\mathbb{W}} \rangle$)...

(ii) Standard Indirect Discourse

a. Jean disait à Marie qu'il l'aimait, et que dans deux jours / *demain...

*Jean was saying to Marie that he loved her, and that in two days / *tomorrow...*

b. $\langle PS^{\lambda}, Reader^{\mathbb{M}}, 1999^{\mathbb{T}}, W^{*\mathbb{W}} \rangle \lambda \langle X^{\lambda}, Y^{\mathbb{M}}, T^{\mathbb{T}}, W^{\mathbb{W}} \rangle$ Jean say to Marie ... that $\lambda \langle x^{\lambda, \mathbb{J}}, y^{\mathbb{M, \mathbb{J}}}, t^{\mathbb{T, \mathbb{J}}}, w^{\mathbb{W}} \rangle$ in-tw-days($\langle x^{\lambda, \mathbb{J}}, y^{\mathbb{M, \mathbb{J}}}, t^{\mathbb{T, \mathbb{J}}}, w^{\mathbb{W}} \rangle$) / *... tomorrow($\langle x^{\lambda, \mathbb{J}}, y^{\mathbb{M, \mathbb{J}}}, t^{\mathbb{T, \mathbb{J}}}, w^{\mathbb{W}} \rangle$)

(iii) Free Indirect Discourse

a. Oui, vraiment, il l'aimait, et demain...

Yes, really, he loved her, and tomorrow...

b. $\langle J^{\mathbb{J}}, M^{\mathbb{J}}, 1960^{\mathbb{J}}, W^{*\mathbb{W}} \rangle \lambda \langle X^{\mathbb{J}}, Y^{\mathbb{J}}, T^{\mathbb{T, \mathbb{J}}}, W^{\mathbb{W}} \rangle$ Yes, really, $X^{\mathbb{J}}$ love $Y^{\mathbb{J}}$... and tomorrow($\langle X^{\mathbb{J}}, Y^{\mathbb{J}}, T^{\mathbb{T, \mathbb{J}}}, W^{\mathbb{W}} \rangle$)...

Our theory is very close to Banfield's. In particular, Banfield had correctly observed that two notions must be distinguished if Free Indirect Discourse is to be analyzed correctly - the *speaker of the actual utterance* (which she calls 'SPEAKER'), and the *author of the matrix context* (which she calls 'SELF'):

"The existence of this style where elements and constructions expressive of subjectivity are not interpreted as the speaker's point of view means that the notion of point of view or subjectivity is not by definition tied to the speaker" (Banfield 1982 p. 93).

Of course our attempt was to *derive* (as much as possible) properties of Free Indirect Discourse from the system we used to analyze indexicality and propositional attitudes - an enterprise Banfield was not concerned with.^{71, 72}

V. OBVIATION

We turn to a brief analysis of Obviative systems. These are of considerable interest on their own, but in addition they will turn out to be quite important for the analysis of Tense, since we will suggest in Chapter 4 that the temporal system of English can fruitfully be analyzed as an obviative system.

As will be recalled from Chapter 1, the essential property of an obviative system is that a distinction is established among 3rd person elements: there is in general one proximate, which we call the 'anchor', and one or several obviatives, which must be different from and less 'salient' than the anchor (we leave it entirely open which technical meaning should be given to the term 'salient'). In some languages there is in addition a 'further obviative' marker, whose anchor must be an element which is itself marked as obviative. The situation was summarized in Chapter 1 with the following diagram:

(52) Proximate - Obviative - Further Obviative

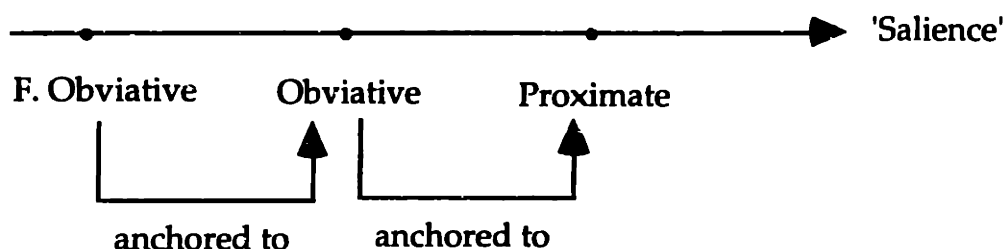

We first introduce a relatively simple system for representing obviation, and then suggest a refinement which, we will claim, can derive the major properties that were sketched in Chapter 1.

5.1. A Simple Analysis

• We must encode formally the fact that the value of an element marked as obviative must be less salient than that of an element marked as proximate; and that the value of an element marked as 'further obviative' must be less salient than that of an obviative. In order to do this, we use three features, which trigger the appearance in the logical forms of certain presuppositions:

(i) The features $\bar{3}$, $\bar{3}$, and $-\bar{3}$ can appear on a variable to mark it as proximate (i.e. as a simple 3rd person variable), as obviative or as further obviative.

(ii) We represent presuppositions explicitly in the logical forms, and write them inside brackets next to the constant or the first occurrence of the variable on which the feature appears. The following cases will arise:

(a) $\bar{3}$ does not trigger the appearance of any presupposition

(b) An element $x^{\mathfrak{3}}$ (with a feature $\mathfrak{3}$ appearing in bold, i.e. interpreted) must be immediately followed by a presupposition of the form $[x^{\mathfrak{3}} <^* y^{\mathfrak{3}}]$, where $y^{\mathfrak{3}}$ is an element marked as proximate. The presupposition will be interpreted as: the value of $x^{\mathfrak{3}}$ must be lower on the salience hierarchy than the value of $y^{\mathfrak{3}}$, or else $x^{\mathfrak{3}}$ has no value.

(c) In a completely parallel fashion, an element $x^{-\mathfrak{3}}$ must be immediately followed by a presupposition of the form $[x^{-\mathfrak{3}} <^* y^{\mathfrak{3}}]$, where $y^{\mathfrak{3}}$ is a variable marked as obviative.

Before going any further, let us consider the logical forms that we will end up with (I leave out the context prefix, as well as the time and world variables):

(53) a. *nakate.w mahke.si.sah wi.sahke.ca.hk*
 leave 3-obv fox obv Wisahkechahk
 ‘Wisahkechahk (prox) left Fox (obv) behind’ [Dahlstrom’s (13), p. 98]

b. ... Wisahkechahk³leave-behind Fox³[Fox³<^{*}Wisahkechahk³] ...

The (partial) logical form in b. includes a presupposition that Fox is less salient than Wisahkechahk.

- To be explicit, we introduce the following system:

(54) a. Inventory of features: add

$\mathfrak{3}$ $-\mathfrak{3}$

b. Syntax

- A constant or a variable of the form $x^{\mathfrak{3}}$ (with $\mathfrak{3}$ in bold) is ill-formed unless it is immediately followed by $[x^{\mathfrak{3}} <^* \xi]$, where ξ is an element with diacritic $\mathfrak{3}$

- A constant or a variable of the form $x^{-\mathfrak{3}}$ (with $-\mathfrak{3}$ in bold) is ill-formed unless it is immediately followed by $[x^{-\mathfrak{3}} <^* \xi]$, where ξ is an element with diacritic $-\mathfrak{3}$

c. Semantics

If s is an assignment, $[[x [x <^* x']]]_s = [[x]]_s$ if $[[x]]_s$ is less salient than $[[x']]_s$

Otherwise $[[x [x <^* x']]]_s$ has no value

d. Lexical Entries

 PROX $\mathfrak{3}$

 OBV $\mathfrak{3}$

 F-OBV $-\mathfrak{3}$

In the preceding example, ‘Fox’ will fail to have a value unless Fox is lower on the salience hierarchy than Wisahkechahk:

$[[\text{Fox}^{\mathfrak{f}} [\text{Fox}^{\mathfrak{f}} <^* \text{Wisahkechahk}^{\mathfrak{f}}]]]_s = [[\text{Fox}^{\mathfrak{f}}]]_s$ only if $[[\text{Fox}^{\mathfrak{f}}]]_s$ is less salient than $[[\text{Wisahkechahk}^{\mathfrak{f}}]]_s$; otherwise $[[\text{Fox}^{\mathfrak{f}} [\text{Fox}^{\mathfrak{f}} <^* \text{Wisahkechahk}^{\mathfrak{f}}]]]_s$ has no value.

5.2. A Refinement

Even if the preliminary discussion that precedes is on the right track, there is something a little puzzling about the system we have introduced. As was observed earlier, there is a clear analogy between the relation of the further obviative to the obviative and that of the obviative to the proximate:

- A further obviative is lexically specified as requiring an obviative anchor.
- An obviative is lexically specified as requiring a proximate anchor.

However this similarity is not formally captured in the system. All we did was use symbols that evoked the similarity ($-^{\mathfrak{f}}$ is to $^{\mathfrak{f}}$ what $^{\mathfrak{f}}$ is to \mathfrak{f}) without capturing it formally. Can we do any better?

One possibility is to postulate that there aren't three, but just two primitive features: $<^*$ and \mathfrak{f} [Note that the feature ' $<^*$ ' is different from the relation symbol ' $<^*$ ', although there is an obvious connection between the two; no confusion should arise in practice since the feature is superscripted while the relation symbol is not]. We further assume that in the syntax 'obviative' is not a primitive notion, but is decomposed into two features: $<^*, \mathfrak{f}$. Similarly a further obviative is decomposed into the feature bundle: $<^*, <^*, \mathfrak{f}$. When a feature $<^*$ is interpreted, it triggers the appearance in the logical form of a presupposition of the form ' $x <^* y$ '. Specifically, we use the following alternative to the system introduced in the previous section:

(55) a. Inventory of features: Add $<^*$

b. Syntax

A variable or a constant of the form $x^{<^* \mathfrak{f}}$ (with $<^*$ in bold), where \mathfrak{f} is a set of person features, is ill-formed unless immediately followed by $[x^{<^* \mathfrak{f}} <^* \xi^{\mathfrak{f}}]$.

c. Semantics

If s is an assignment, $[[x [x <^* x']]]_s = [[x]]_s$ if $[[x]]_s$ is less salient than $[[x']]_s$

Otherwise $[[x [x <^* x']]]_s$ has no value

d. Lexical Entries

PROX \mathfrak{f}

OBV $<^*, \mathfrak{f}$

F-OBV $<^*, <^*, \mathfrak{f}$

This system is simpler than our previous formalization, since we have now strictly less primitives and strictly less rules. The example mentioned before is now analyzed as:

- (56) a. *nakate.w mahke.si.sah wi.sahke.ca.hk*
leave 3-obv fox obv Wisahkechahk
 'Wisahkechahk (prox) left Fox (obv) behind' [Dahlstrom's (13), p. 98]

b. ... Wisahkechahk³leave-behind Fox³{Fox³<^{*}Wisahkechahk³} ...

Since Fox³ bears the feature <^{*}, it must be followed by [x³<^{*}ξ³]. The feature bundle {<^{*}, 3} has exactly the same effect as the single feature 3 in the previous formalization. But there are several advantages to the new system:

(i) The number of primitives and the number of rules has been reduced.

(ii) The underlying features reflect rather closely the overt morphology which is found in Potawatomi according to Hockett. We repeat his example:

- (57) a. /PROX/ = *waposo*
rabbit
- b. /OBV/ = *waposo* -n
rabbit OBV
- c. /F. OBV/ = *waposo* -n- -un-
rabbit OBV OBV

With the previous system, there was no particular reason to expect that reduplicating an obviative morpheme could yield a further obviative. But within the new system this is natural, since the the further obviative contains two instances of the feature '<^{*}':

- (58) a. /PROX/ = *waposo*
rabbit
 3
- b. /OBV/ = *waposo* -n
rabbit OBV
 3 <^{*}
- c. /F. OBV/ = *waposo* -n- -un-
rabbit OBV OBV
 3 <^{*} <^{*}

What seems to be happening in Hockett's example is that the features of a single bundle ({3, <^{*}, <^{*}}) can simply be expressed piecemeal [such a process appears to exist in the morphology of other languages, and is called 'Fission' in Distributed Morphology].

(iii) Finally, there might be a third advantage to the new system. As was observed in Chapter 1, there are cases in which a further obviative is expected in a language that does not have the resources to express it. In these cases a (simple) obviative is used. Why should that be?

Consider an example. As was noted in Chapter 1, in possessive constructions the possessed is always less salient than the possessor, *except* (in Cree) when the possessor is itself obviative:

- (59) a. *possessor=obviative and possessed=proximate
 b. *possessor=proximate and possessed=proximate
 c. Ok possessor=proximate and possessed=obviative
 d. Ok possessor=obviative and possessed=obviative

Let us assume that it is indeed correct that *in the syntax* the possessed is always less 'salient' than the possessor. That means that the appearance of an obviative (rather than of a further obviative) on the possessed in d. can only be a fact of morphology:

- | | | |
|--------------------|------------------------|---------------------|
| (60) d. | Ok possessor=obviative | possessed=obviative |
| <u>Syntax:</u> | ᑖ, < | ᑖ, <, < |
| <u>Morphology:</u> | OBV<, ᑖ | OBV<, ᑖ |

Within the new system there is a natural way to describe what seems to be going on: the morphology of Cree expresses maximally the features present in the syntax. But since Cree has not further obviative (and since in this case, contrary to what happens in Hockett's Potawatomi example, the features cannot be expressed piecemeal), OBV<, ᑖ is the most highly specified morpheme compatible with the features in the bundle {ᑖ, <, <}, and therefore it must be inserted. By contrast, when the possessor is proximate, the possessed must bear obviative features in the syntax, and since OBV<, ᑖ is more highly specified than PROXᑖ, it must be inserted in the morphological component.

- | | | |
|--------------------|------------------------|---------------------|
| (61) c. | Ok possessor=proximate | possessed=obviative |
| <u>Syntax:</u> | ᑖ | ᑖ, < |
| <u>Morphology:</u> | PROXᑖ | OBV<, ᑖ |
| | | not: PROXᑖ |

In the old system, the case in which the possessor is obviative would be represented as follows:

- | | | |
|--------------------|------------------------|---------------------|
| (62) d. | Ok possessor=obviative | possessed=obviative |
| <u>Syntax:</u> | -ᑖ | -ᑖ |
| <u>Morphology:</u> | OBVᑖ | OBVᑖ |

But since in this case there is no formal connection between the feature expressed in the morphology (namely -ᑖ) and that which appears in the syntax (-ᑖ), the pattern under study cannot be explained.

CHAPTER 4. PRESENT AND PAST TENSES

If the Hypothesis of Semantic Uniformity is correct, we should now have at our disposal all the tools we need to account for Tense: a simple reinterpretation of the system developed for Person should yield an analysis of the temporal phenomena introduced in Chapter 1. In this chapter we argue that this is essentially correct for the present tense, the simple past and the pluperfect (the future is briefly considered in the Appendix).

Our enterprise is one of unification. Thus our primary goal is *not* to show that some fashionable theory T should be replaced with a theory T' which is of the same order of complexity as T, but makes better predictions. By itself, such an enterprise would not provide any argument for Semantic Uniformity. The logic of the present work is different: we wish to show that no theory of tense is needed at all, and that all the morpho-syntactic features and interpretive rules that are needed were already used in the person domain. Accordingly, we would be content to take some existing theory of tense, leave it untouched and demonstrate that its principles are independently motivated in the person domain⁷³.

This is not exactly what we do, for several reasons. First, some of the phenomena we discuss (logophoric tense, Free Indirect Discourse) have not - to our knowledge - been treated in any similar way in the formal literature. Second, even in the discussion of Sequence of Tense, where our analysis is rather close to Abusch 1997, the parallels with Person force us to make subtly different predictions. These are, unfortunately, somewhat hard to test (we do provide some evidence that they are correct, however). Still, deriving new predictions is not our main goal, and the reader is asked *not* to consider this chapter in isolation from the previous one, since the thrust of the argument is precisely that Person and Tense can and should be treated on a par.

Exactly as in the case of Person, our account has three main features:

- (i) We develop a *Null Theory* of the cross-linguistic differences observed in the tense domain. We claim that the patterns observed cross-linguistically are not the result of specific rules (e.g. 'Sequence of Tense' rules) that exist in some languages but not in others. Rather, the typologies result solely from the interaction between the lexical specifications of different morphemes. This was precisely the logic we followed in the treatment of temporal adverbials in English, and of Person in English and Amharic.
- (ii) In Chapter 3 we had to postulate a difference between the formal treatment of Person and that of English temporal adverbials. The same split will be found here, and tense will pattern with pronouns rather than with temporal adverbials. The split is instantiated in two cases. First, in Free Indirect Discourse the English present cannot be shifted, whereas 'tomorrow' can be. Second, there are numerous cases in which tenses are treated as bound variables, and in some of them (most notably, in Sequence of Tense environments) the temporal features remain uninterpreted. No such phenomena exist with 'tomorrow'.
- (iii) As in our treatment of Person, we will give a detailed account of the morpho-syntactic features that are present at S-Structure, and get spelled-out in the morphological component. As a result, some of the representations we use might look complicated. But the reader is asked to bear in mind the following:

a. Alternative analyses typically do *not* account for the morphology, or at least not in the same representations as are used for logical forms.

b. The set of primitives that we use is small; and only few rules are needed. But as expected when the *data* to be accounted for are complex, the primitives interact in intricate ways. This, of course, is precisely what is desired if complex phenomena are to be derived from a simple system. But as a result, the representations are themselves somewhat complicated. In order to simplify things, we will often leave out those parts of the representations that are not crucial to the analysis (for instance when we deal with tense we will often leave out world variables).

We start with a presentation of the correspondence between the analysis of Person and that of Tense, and then account for Sequence Phenomena, Logophoricity and Free Indirect Discourse.

I. SETTING UP THE CORRESPONDENCE BETWEEN PERSON AND TENSE

The treatment of Tense is essentially parallel to that of Person. One apparent difference is that the analysis of Obviation, which only played a marginal role in our theory of Person, will be of central importance here. If we are right, this results from a typological accident: for an English speaker, obviative systems are highly exotic in the personal domain, but utterly common in the temporal one (except, of course, that in the latter case they are not *called* 'obviative'). And since considerable attention has been devoted to the tense system of English, we too must study it in some detail, and thus give an account of Obviation with tense.

1.1. The General Idea

Here, then, is the Correspondence we wish to develop:

(i) An indexical tense, just as an indexical pronoun, is treated as a variable bound by the author coordinate of a context:

-In simple cases, 'I' and 'you' in English are bound by the author or by the hearer coordinates of the matrix context⁷⁴. Their Amharic counterparts have the additional option of being bound by a coordinate of an embedded context.

-Similarly, the English present tense is (in simple cases) bound by the time coordinate of the matrix context. But its Russian counterpart can, in addition, be bound by the time coordinate of an embedded context. This is represented below [as elsewhere, <x, y, t, w> is an embedded context; <X, Y, T, W> represents a matrix context]:

(1) Indexical Pronouns and Indexical Tense as Bound Variables

a. Indexical Pronouns

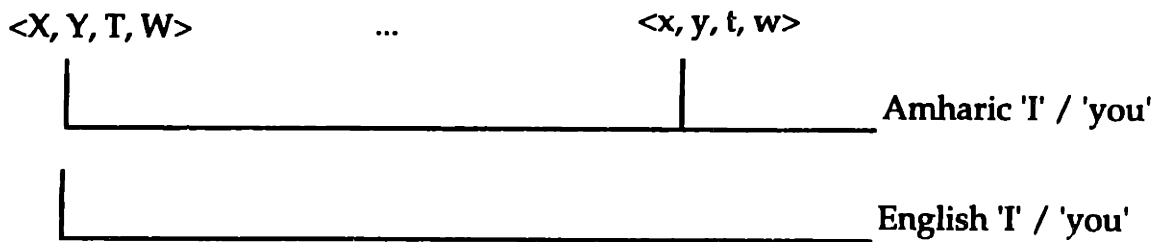

b. Indexical Tense

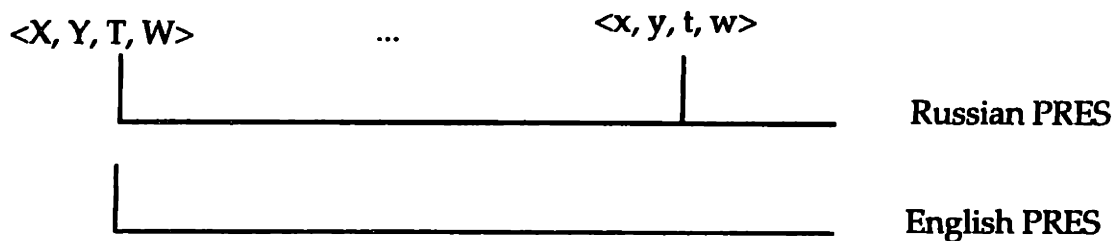

(ii) Logophoric pronouns were formalized as variables that are obligatorily bound by the speaker or hearer coordinate of an embedded context. Similarly logophoric tense (the Konjunktiv I in German) will be analyzed as a variable which is obligatorily bound by the time coordinate of an embedded context:

(2) Logophoric Pronouns and Logophoric Tense

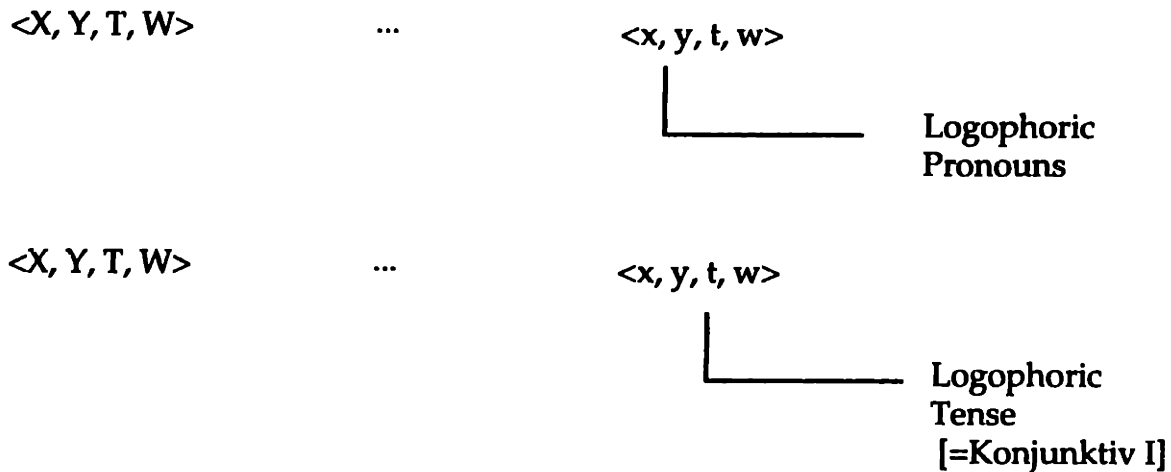

(iii) The temporal counterpart of the Obviative system of Algonquian is found in the Present/Past/Pluperfect system of English:

(3) a. Proximate - Obviative - Further Obviative

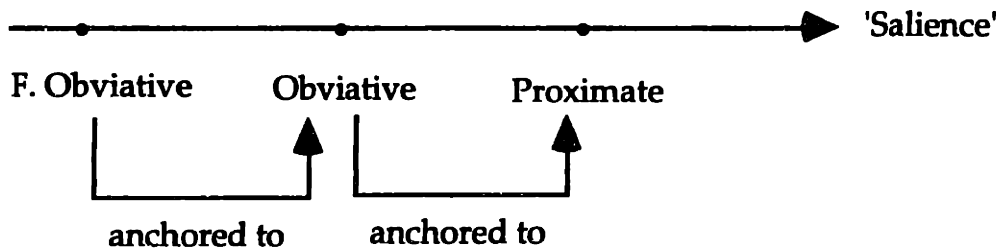

b. Present - Past - Pluperfect

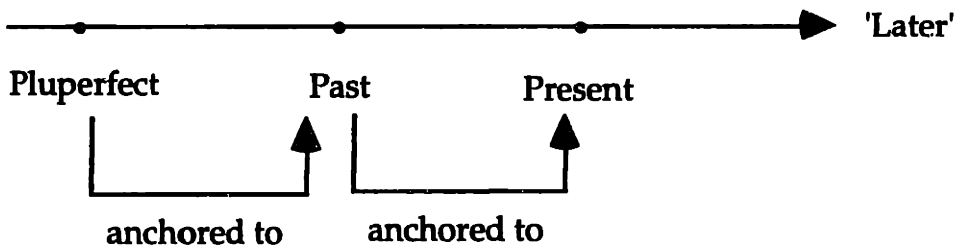

It should be observed at this point that we are departing from a completely strict version of the Hypothesis of Semantic Uniformity. While the obviative features that we use here are morphologically and semantically parallel in both domains, they apply to different types of anchors:

- An obviative pronoun is anchored to a 3rd person (a proximate), i.e. to a variable which is *not* bound by a coordinate of a context.
- By contrast, a past tense is anchored to a present, i.e. to a variable bound by a coordinate of a context (in simple cases).

We can only speculate about the source of the difference, and will leave this as an unresolved (but relatively minor) difficulty. [An attractive possibility would be to analyze a 3rd person as an obviative 1st/2nd person - or rather, as an 'obviative x', where x is the feature (call it PSE for 'Participant to the Speech Event', following Halle) that 1st and 2nd person have in common. This would make the person domain completely parallel to tense. However we have no evidence for such an analysis at this point.]

For the rest, we will rely on the same semantic and morphosyntactic rules as in the treatment of Tense. We go briefly through the main components of the analysis.

1.2. Propositional Attitudes: Temporal De Re vs. De Se

The analysis of attitudes developed in Chapter 2 treats tense and individuals on a par. And since it has been argued at length that a distinction is needed between De Re and De Se readings in the pronominal domain, we expect to find the same distinction with tense. Thus we expect to find logical forms of the following sorts [where $ATT(x, t,$

w) is an attitude operator, for instance ‘x hopes at t in w that...’, which quantifies over a context of the form $\langle x', t', w' \rangle$]:

(4) a. De Re vs. De Se with Person

De Re: $ATT(x, t, w) \lambda \langle x', t', w' \rangle \dots x \dots$

De Se: $ATT(x, t, w) \lambda \langle x', t', w' \rangle \dots x' \dots$

b. De Re vs. De Se with Tense

De Re: $ATT(x, t, w) \lambda \langle x', t', w' \rangle \dots t \dots$

De Se: $ATT(x, t, w) \lambda \langle x', t', w' \rangle \dots t' \dots$

This is the expectation. And indeed Ogihara 1996, Abusch 1997 and von Stechow 1995 all assume that tense in attitude environments can be read either De Se or De Re⁷⁵. But we should be clear about the nature of the argument: it hinges almost entirely on an analogy between pronouns and tense. In the pronominal domain, the crucial reason for positing De Se readings was that PRO was unambiguously De Se (as are, apparently, logophoric pronouns). It was thus relatively easy to construct a situation in which a De Re structure can be used, but PRO cannot be (Smith hopes that the terrific candidate he sees on TV will be elected, etc.). But to our knowledge no such arguments have been offered in the temporal domain. Class hand-outs by Heim mention examples with infinitives (ECM structures) as a paradigm example of temporal De Se, but no situation is set up in which a truth-conditional *difference* arises between a De Se and a De Re structure. Maybe for good reason. Although it is easy to construct a situation that has the right properties, the judgments are particularly delicate. Here is an attempt:

(5) English: both a ‘de se’ and a ‘de re’ reading (?) (D. Embick, p.c.)

Scenario: On Tuesday, Mary read a chart that read: ‘Tuesday - doctor on duty: John’. However Mary mistakenly thought that that day’s date was Thursday.

a. #On Tuesday Mary believed John to be the doctor on duty

<b. On Tuesday Mary believed that John was the doctor on duty>

The hope is that infinitive structures should be unambiguously De Se not just with respect to PRO (in cases of Control), but also with respect to the tense the embedded clause (in ECM or Control examples). Since Mary has a non-De Se belief with respect to time (she does not realize that Tuesday is the time of her thought act), the prediction is that the infinitive structure should be disallowed here (b. will be discussed later). But unfortunately the judgments are subtle.

Many researchers write as if there were a clear conceptual argument for positing De Se readings with respect to tense. All they show, however, is that attitude operators in natural language are compatible with De Se *situations* with respect to time. But this does not demonstrate that there are separate De Se *readings*. This is the temporal version of the problem we encountered in Chapter 2: it is possible to maintain both that

(i) attitude operators are *compatible* with a De Se situation, but that (ii) there are no De Se readings in the grammar⁷⁶.

1.3. The Present as a Bound Variable

On an intuitive level, it is clear that a present tense normally refers to the time of the speech act. Similarly 1st and 2nd person pronouns denote the protagonists of the speech act. The natural idea, then, is that the formal device used for 1st and 2nd person pronouns should carry over to tense. Thus we will treat a present tense as a variable which, in simple cases, is bound by the time coordinate of a matrix context. [In more complex cases, a present tense, just as a 1st or a 2nd person pronoun, may be bound by something else, as we will see shortly].

Formally, exactly the same system as was used for indexical pronouns can be applied to tense. In fact all the pieces we need are already in place, since we have from the beginning used contexts that had a time coordinate. And together with person diacritics, we had introduced time diacritics. 'I think' had thus been formalized in the following way:

- (6) a. I think
 b. $\langle X^A, Y^B, T^T, W^W \rangle \lambda \langle X^A, Y^B, T^T, W^W \rangle X^A / I_A / \text{think at } T^T \text{ in } W^W$

The variable T^T played of course precisely the same role that X^A did. The formalism used so far gives a straightforward way of handling the present: a present tense simply spells-out a time variable that bears the diacritic 'T'. The system would obviously have to be enriched to handle cases in which an interval rather than a moment is needed in the interpretation (e.g. in 'Every morning I wake up at 9:00 am'), but for present purposes this simple formalization will suffice.

Let us recall what were the cases that had lead us to posit that 1st and 2nd person pronouns could be bound variables. While we ended up positing that indexical pronouns *could* always be treated as bound variables, the motivating cases were those in which they *had* to be treated as bound. This, in turn, happened when 'I' could not be taken to refer to the speaker, so that the 1st person features appeared to remain uninterpreted.

(i) We had started from Heim's examples, which show that a 1st person pronoun is sometimes interpreted as a bound variable. The facts were the following:

- (7) a. Only I do my homework
 b. $[\text{only } I] \lambda x_i x_i \text{ do } x_i \text{'s homework}$

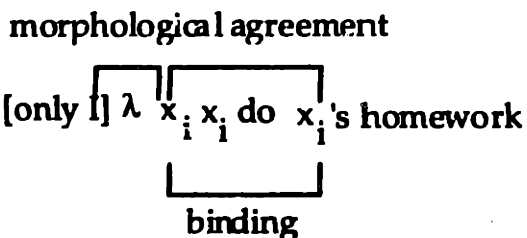

The final account was that in structures of this type the embedded pronoun inherited its features from an element that was not its binder:

- (7) a. [Only I] λx x does x's homework
 b. $\langle X^{*A}, Y^{*B}, T^{*T}, W^{*W} \rangle \lambda \langle X^A, Y^B, T^T, W^W \rangle$
 [Only X^A] $\lambda y^A y^A$ does y^A 's homework

The general statement of the rule that enforced this pattern of agreement (and was simply stipulated) was the following:

- (8) [Only x] $\lambda y \phi$ is well-formed only if x and y bear the same diacritics.

Do similar cases exist in the temporal domain? Almost. Consider the following:

- (9) **Situation:** The Concord took off from LAX at 6:00 pm, and is scheduled to land in Paris exactly three hours later. It's now 9:00 pm L.A. time.
 (1) Only now is the Concord in Paris. [Therefore it wasn't there before]
 (2) $C^* \lambda C$ [Only now] λt [the Concord is in Paris at t]

In this case the present tense features remain uninterpreted, since the bound variable must range over times that lie in our past⁷⁷. Does this follow from the system outlined so far?

It does, but there is one difference between this sentence and Heim's example. In the latter case the element following 'only' was a pronoun: 'only I'. The situation is different here, since an adverb ('now') appears next to 'only'. Furthermore, we know that 'now' must be formalized as a function taking a matrix context as argument⁷⁸, rather than as a variable bound by the time coordinate of the embedded context. This is because in Free Indirect Discourse 'now' can be shifted: 'Yes, he would marry her... but not now, maybe tomorrow'. So in standard cases 'now' must have the following analysis:

- (10) $\langle X^{*A}, Y^{*B}, T^{*T}, W^{*W} \rangle \lambda \langle X^A, Y^B, T^T, W^W \rangle \dots \text{now}(\langle X^A, Y^B, T^T, W^W \rangle) \dots$

Since 'now' is not a variable, it cannot inherit the feature \bar{T} from the time coordinate of the matrix context. Therefore if it does bear the feature \bar{T} , it can only be because the diacritic is interpreted (and thus \bar{T} must appear in bold). Furthermore, since 'now' *does* denote the time of the actual speech act, it *can* bear the feature \bar{T} . And according to the principle defined in Chapter 3, if it can, it must, since the injunction was:

- (11) Use features whenever possible!

As a result, the following representation should be posited:

- (12) $\langle X^{*A}, Y^{*B}, T^{*T}, W^{*W} \rangle \lambda \langle X^A, Y^B, T^T, W^W \rangle \dots [\text{now}(\langle X^A, Y^B, T^T, W^W \rangle)]^{\bar{T}} \dots$

The preceding example is now parallel to Heim's 'only I' sentence:

- (13) a. [Only I] λx x does x's homework
 b. $\langle X^{*d}, Y^{*f}, T^{*f}, W^{*f} \rangle \lambda \langle X^d, Y^f, T^f, W^f \rangle$
 [Only X^d] λy^d y^d does y^d 's homework
- (14) a. [Only now] is the Concord in Paris.
 b. $\langle X^{*d}, Y^{*f}, T^{*f}, W^{*f} \rangle \lambda \langle X^d, Y^f, T^f, W^f \rangle$
 [Only [now($\langle X^d, Y^f, T^f, W^f \rangle$)]^f] λt^f [the Concord be in Paris at t^f]

Since 'now' must bear the feature \bar{f} , the agreement principle in (8) ensures that \bar{f} must appear on the time variables that follow 'only now' - a correct result.

(ii) There was a second case in which we had posited that 1st and 2nd person features could remain uninterpreted. This happened when a De Se reading was obtained from a verb whose agent was in the 1st or 2nd person:

- (15) a. I hope that I am elected
 b. $\langle X^{*d} \dots \rangle \lambda \langle X^d \dots \rangle X^d$ hope ... $\lambda \langle x^{*d} \dots \rangle x^{*d}$ /I_A/ be elected...
- (16) a. You hope that you are elected
 b. $\langle \dots Y^{*f} \dots \rangle \lambda \langle \dots Y^f \dots \rangle Y^d$ hope $\lambda \langle x^{*f} \dots \rangle x^{*f}$ /you_f/ be elected

How did we know that De Se readings are available in these cases? The argument, which was given for 'he' but carries over to embedded 'I' and 'you', was indirect. We had for instance observed in Appendix II (Chapter 2) that pronouns that are unambiguously read De Re yield a disjoint reference effect in an unmarked De Se situation. No such effect holds in (15) and (16), which suggests that the embedded pronoun can be read De Se.

Whatever their worth, the arguments carry over to the temporal case:

- (17) a. John hopes that it is raining
 b. $\langle \dots T^{*f} \dots \rangle \lambda \langle \dots T^f \dots \rangle$ John hopes at T^f $\lambda \langle \dots t^{*f} \dots \rangle$ it rains at t^{*f}

The rule of feature agreement that is required was already stated as applying to every coordinate of a context, so that nothing new need be said. The rule simply stipulates that every coordinate of an embedded context inherits the features of the corresponding elements of the speech- or thought-act that defines the attitude operator:

(18) If ϕ is a well-formed formula and if ATT is an attitude operator,

$ATT(x^d, (y^b), t^f, w^f) \lambda \langle x^{*d}, (y^{*b}), t^{*f}, w^{*f} \rangle \phi$ is a well-formed formula.

[where d, b, f, g stand for the set of all features that appear on $x, y, t,$ and w respectively]

(iii) In the case of tense, there is a third type of environment in which it is useful to allow for transmission of a \bar{T} feature to an element which is *not* bound by a coordinate of the matrix context. Consider the following:

- (19) a. Mary will say tomorrow that John IS crying (at the time of her speech act)
 b. Mary will meet a person who IS crying (at the time of the meeting)
 a'. Mary might say tomorrow that John IS crying (at the time of her speech act)
 b'. Mary might meet tomorrow a person who IS crying (at the time of the meeting).

In these cases it is clear that the embedded present tense does not refer to the time of the *actual* speech act. But if we treat 'will' and 'might' as being morphosyntactically present, we can state an agreement rule (similar to the one introduced for attitude operators) that will allow the embedded tense to inherit a \bar{T} feature, and thus to be spelled-out as a present tense. These cases are considered in more detail in Chapter 5.

1.4. Past tenses as obviatives (English)

With the present tense taken care of, the next step in our analysis is to treat the past tense as an obviative, and the pluperfect as a further obviative. [The obviative analysis of past tenses will become crucial only in the discussion of the Pluperfect; much of what we will have to say about Sequence of Tense does not hinge on this.]

If the Hypothesis of Semantic Uniformity is correct, there should be a simple correspondence that maps personal obviation into the temporal system.

a) The reinterpretation

Let us recall first what our final analysis of personal obviation was at the end of Chapter 3:

- (20) a. Inventory of features: Add \langle^*

b. Syntax

A variable or a constant of the form $x^{\langle^* \bar{\imath}}$ (with \langle^* in bold), where $\bar{\imath}$ is a set of person features, is ill-formed unless immediately followed by $[x^{\langle^* \bar{\imath}} \langle^* \xi^{\bar{\imath}}$].

c. Semantics

If s is an assignment, $[[x [x \langle^* x']]]_s = [[x]]_s$ if $[[x]]_s$ is **less salient than** $[[x']]_s$
 Otherwise $[[x [x \langle^* x']]]_s$ has no value

d. Lexical Entries

PROX $\bar{\imath}$

OBV $\langle^*, \bar{\imath}$

F-OBV $\langle^*, \langle^*, \bar{\imath}$

Let us now reinterpret this system within the temporal domain, with the stipulation (discussed before) that the temporal analogue of a proximate 3rd person is a present tense. The correspondence is the following:

- The inventory of features is the same in both domains.
- The relation symbol '<*' is rewritten as '<', and is reinterpreted as temporal priority
- Morphologically, PROX is reinterpreted as PRES, OBV as PAST, and F-OBV as PLUP. The result is the following system:

(21) a. Inventory of features: Add <

b. Syntax

A variable or a constant of the form $t^{\langle \delta \rangle}$ (with < in bold), where δ is a set of tense features, is ill-formed unless immediately followed by $[t^{\langle \delta \rangle} < \xi^{\langle \delta \rangle}]$.

[In what follows we understand this well-formedness constraint as applying to variables that are not immediately adjacent to a λ -abductor or a quantifier. Thus ' $\lambda t^{\langle \delta \rangle} \dots t^{\langle \delta \rangle} [t^{\langle \delta \rangle} < \xi^{\langle \delta \rangle}] \dots$ ' is well-formed]

c. Semantics

If s is an assignment, $[[[t < t']]]_s = [[t]]_s$ if $[[t]]_s$ is prior to $[[t']]]_s$
 Otherwise $[[[t < t']]]_s$ has no value

d. Lexical Entries

PRES $_{\uparrow}$

PAST $_{<, \uparrow}$

PLUP $_{<, <, \uparrow}$

b) Illustration

- The system works essentially as in the person domain - with a twist. In the tense domain a variable with past/pluperfect features may be bound by an overt or a covert existential quantifier. We will thus end up with three cases (examples from Partee 1984):

(22) a. Case 1: A past tense is bound by a covert existential quantifier.

Sam got drunk

b. Case 2: A past tense is bound by an overt quantifier

Whenever there was a party, Sam got drunk

c. Case 3: A past tense is anaphoric

There was a party on Monday and Sam got drunk

[From the present perspective, the availability of a mechanism of covert existential quantification in the temporal domain might appear puzzling, since there does not appear to be any comparable device in the person domain. But appearances are deceptive. There *are* cases in which a verb in the 3rd person receives an existential reading in the absence of an overt quantifier. Consider the following case from Russian:

- (23) a. *stuCat* [Russian; Ora Matushansky, p.c.]
are-knocking (3pl.)
 'Someone is knocking'
- b. \neq *oni stuCat*
they are-knocking (3pl.)
 'They are knocking' (not: someone is knocking)

a. is read existentially, and furthermore the contrast with b. makes it unlikely that the subject is 'really' definite but that the existential force is somehow obtained in the pragmatics⁷⁹. If this were the case, there would be no reason for the difference between cases with an overt and a null pronoun]

For simplicity, we will almost always leave the variable introduced by a past tense free, with the convention that, depending on the environment in which it appears, the variable may either be bound by a quantifier or anaphorically related to some salient temporal element.

- In simple cases, the anchor of a variable with past tense features is the time coordinate of the matrix context. This will yield partial logical forms as in a., which gets interpreted as in b. (under an assignment s):

- (24) a. LF: $t^{\leftarrow} [t^{\leftarrow} < T^{\rightarrow}]$
 b. Interpretation: $[[t^{\leftarrow} [t^{\leftarrow} < T^{\rightarrow}]]]_s = [[t^{\leftarrow}]]_s$ if $[[t^{\leftarrow}]]_s$ is prior to $[[T^{\rightarrow}]]_s$
 Otherwise $[[t^{\leftarrow} [t^{\leftarrow} < T^{\rightarrow}]]]_s$ has no value⁸⁰

- In more complex cases, the anchor of the variable with past tense features might *not* be bound by the time coordinate of the matrix context. These are precisely the environments in which an English present tense appears to be shifted. Clear cases arise with modals and 'will':

- (25) a. Mary will say in a week that John WAS crying two days earlier.
 b. In a week Mary will meet a person who WAS crying two days earlier.
 a'. Mary might say in a week that John WAS crying two days earlier.
 b'. In a week Mary might meet a person who WAS crying two days earlier.

These are of course similar to the examples with a shifted present tense that were mentioned above. The advantage of the obviative analysis of the past tense is that it captures straightforwardly a generalization that seems to apply in a number of cases: a past tense can be shifted just in case a present tense can be. In our system, the reason for this is that the past tense is just, by definition, an obviative present

- This system also has the advantage of extending straightforwardly to the pluperfect. In the latter case the *anchor* must bear past tense rather than present tense features. Consider the following:

- (26) a. <John got sick because> it had rained
 b. $\langle \dots T^{\rightarrow} \dots \rangle \lambda \langle \dots T^{\rightarrow} \dots \rangle$ J. gets sick at $t^{\leftarrow} [t^{\leftarrow} < T^{\rightarrow}] \dots$
 because it rains at $t^{\leftarrow} [t^{\leftarrow} < t^{\leftarrow}]$

The first line contains nothing new. On the other hand a feature bundle '<, <, T' appears on the time variable of the second line. The first feature < appears in bold, and must therefore be followed by a presupposition of the form [$t^{<T} < t^{<}$]. This, in turn, correctly forces a reading in which it rained *before* John got sick.

c) Advantages of the system

In the person domain, the corresponding analysis of obviation was found to have three main advantages:

(i) Since obviatives and further obviatives were decomposed into bundles of just two primitive features (with obviative = <*, 3 and further obviative = <*, <*, 3), the system of primitives was particularly simple. Obviously the same observation applies to the decompositional analysis of the past tense and of the pluperfect.

(ii) The decompositional analysis of obviation allowed the morphology to reflect particularly closely the features present in the syntax:

(27)	a. /PROX/	=	waposo		
			rabbit		
			3		
	b. /OBV/	=	waposo	-n	
			rabbit	OBV	
			3	<*	
	c. /F. OBV/	=	waposo	-n-	-un-
			rabbit	OBV	OBV
			3	<*	<*

The same observation applies to periphrastic tenses in French, German or Yiddish:

(28)	a. /PRES/	=	(ikh)	heył		
			I	cure		
				T		
	b. /PERF/	=	ikh	hob	geheyłt	
			I	have	cured	
				T	<	
	c. /PLUP/	=	ikh	hob	geha-t	geheył-t
			I	have	ha-d	cur-ed
				T	<	<

(iii) Finally, it was observed that the decompositional analysis could explain straightforwardly why in certain cases an obviative was inserted in the morphology even though a *further* obviative was expected. This, it was argued, happened because the language in question (in this case, Cree) lacked the morphological resources to

express a further obviative, with the result that the most highly specified form compatible with the features present in the syntax was a simple obviative, as in the following example [it will be recalled that the generalization about possessive constructions in Algonquian is that the possessed is always less 'salient' than the possessor; since the possessor is obviative, one expects the possessed to have further obviative features]:

(29)	Ok possessor=obviative	possessed=obviative
<u>Syntax:</u>	‡, <	‡, <, <
<u>Morphology:</u>	OBV<,‡	OBV<,‡

As was observed in Chapter 1, similar cases arise in the tense domain. Sometimes a double-pluperfect (i.e. a past form of the pluperfect) is expected in English. But because there is no double pluperfect, a pluperfect is inserted in the morphological component:

- (30) a. Five years ago, Peter told me: "Even though John arrived on Monday, Mary left on Tuesday".
 b. Five years ago, Peter told me that even though Mary HAD arrived on Monday, John HAD left on Tuesday.
 c. Five years ago Peter told me: "When Mary arrived, John had already been (# was already) out of town for five days."
 d. Five years Peter told me that when Mary HAD arrived, John HAD already been out of town for five days.

- (30') a. Il y a cinq ans, Pierre m'a dit: "Alors que Jean est arrivé lundi, Marie est partie mardi"
 b. Il y a cinq ans, Pierre m'a dit qu'alors que Jean ÉTAIT (#est) arrivé lundi, Marie ÉTAIT (#est) partie mardi"
 c. Il y a cinq ans, Pierre m'a dit: "Lorsque Jean est arrivé, Marie ÉTAIT déjà partie"
 d. Il y a cinq ans, Pierre m'a dit que lorsque Jean ÉTAIT arrivé, Marie ÉTAIT déjà partie.

a. and b. simply show that an utterance with a past tense verb must be reported in the pluperfect when the matrix verb is in the past. In c. the pluperfect is obligatory in the main clause of the direct discourse. Thus we would expect the report in d. to involve one additional layer of past participle morphology (i.e. 'had had left'). However this does not happen and the pluperfect is inserted instead.

The suggestion, then, is that this case is parallel to the person case discussed before, with the only difference that here a 'further further obviative' is expected (i.e. a form with features <, <, <, T) even though the most highly specified form which is available is a further obviative:

- (31) d. ... when Mary HAD arrived, John HAD already been out of town....

<u>Syntax:</u>	‡, <, <	‡, <, <, <
<u>Morphology:</u>	PLUP<, <, ‡	PLUP<, <, ‡

The conclusion, then, is that the unification of obviation and tense is not only possible (and therefore conceptually desirable) given what we know, but it also derives a few non-trivial properties of both systems. However since very little is known about obviative systems in the person domain, much empirical work will be needed to determine whether the unification is fruitful, or spurious.

II. SEQUENCE OF TENSE (ENGLISH VS. RUSSIAN)

With this framework in mind, we turn to a discussion of Sequence of Tense phenomena. We would like to show (i) that the system developed so far suffices to account for the contrast between Russian and English, which (we claim) is but the temporal version of the contrast between Amharic and English 1st/2nd person pronouns; and (ii) that the cases in English in which tense features remain uninterpreted are predicted from the mechanism of feature transmission that was posited for the person domain. Our main goal, then, is to show that no domain-specific stipulations are needed in the treatment of Tense. Since our enterprise is one of unification, we will provide a systematic comparison between Sequence of Person and Sequence of Tense. The typological correspondence was already discussed in Chapter 1 in a preliminary form (it will be refined below):

(32) Sequence of Tense vs. Sequence of Person

<X, Y, T, W> is the matrix context

<x, t, w> is an embedded context

a. Person

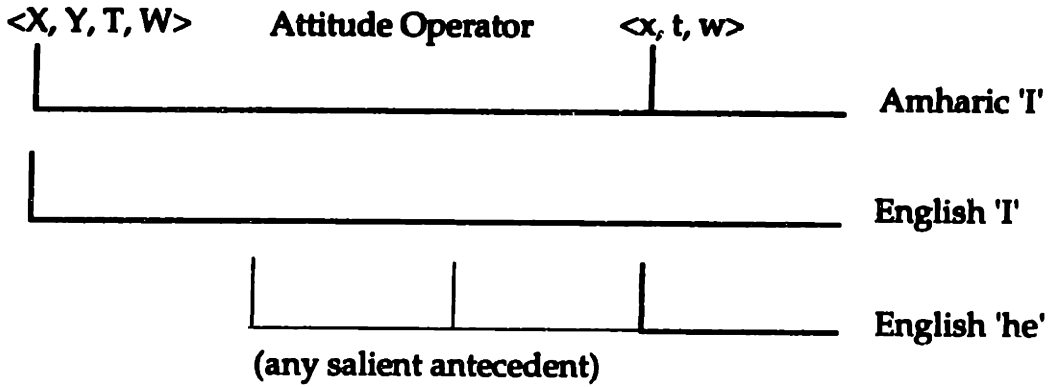

b. Tense

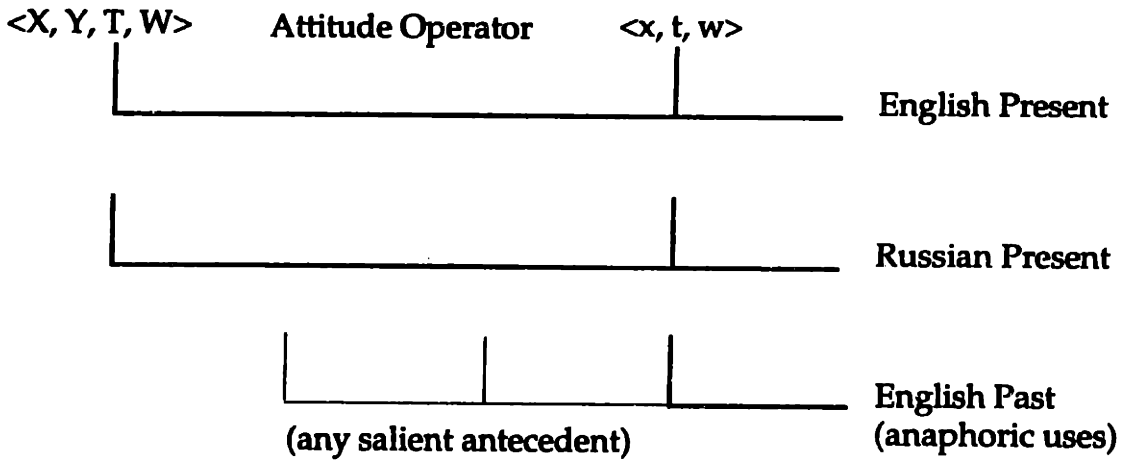

2.1. The Null Hypothesis vs. the History

From our perspective, Sequence of Tense does not display any special properties. The major facts were already observed in the person domain:

(i) The Amharic 1st person pronoun could either spell-out a feature λ , inherited from the author coordinate of a matrix context, or a feature λ , transmitted by the author coordinate of an embedded context. English 'I', on the other hand, could only spell-out λ . The same typology arises with tense: the Russian present may choose to either express a feature \mathbb{T} , inherited from the time coordinate of a matrix context, or a feature

t , transmitted by the time coordinate of an embedded context. But the English present may only spell-out \bar{t} .

(ii) In English a pronoun read De Se is bound by a coordinate of an embedded context, but inherits its features from an argument of the matrix verb / operator. Since these features are a result of agreement, they remain uninterpreted. Exactly the same phenomenon exists in the temporal domain: a tense read De Se under an attitude verb inherits the tense features of the matrix verb. And these remain uninterpreted in the embedded clause. From our perspective, there is nothing surprising about this: the rules of agreement that were defined for Person apply to Tense, unmodified.

(33) a. Agreement vs. Binding with Person

Smith hopes that $\lambda\langle x, t, w \rangle$ [he is elected at t in w]

┌──────────────────────────┐
morphological agreement

┌───┐
binding

b. Agreement vs. Binding with Tense

Smith thought- t that $\lambda\langle x, t, w \rangle$ [it WAS raining]

┌──────────────────────────┐
morphological agreement

┌───┐
binding

Of course the agreement rule we had posited for Person was a mere stipulation. From a cross-categorial perspective, however, the point is that the *same* stipulation will do for both Person and Tense.

(iii) As in the case of Person, we do not expect any locality conditions to be intrinsically tied to either De Se readings or morphological agreement. It could be that some temporal analogues of PRO have certain locality conditions, but this would presumably be an independent property of the item in question, not something that followed from the rest of the system.

These, then, are the main properties of the Null hypothesis. But the history of the discussion of Sequence of Tense has proceeded along rather different lines.

(i') First, the distinction between Russian and English has hardly been discussed at all, except by Kondrashova in a syntactic framework. The typological contrast that has received most attention is that between English and Japanese (discussed in Ogihara 1996) - something we have nothing to say about at this point.

(ii') The fact that has most puzzled researchers is that in English tense features remain uninterpreted in Sequence of Tense environments. An essential aspect of the question, then, is morphosyntactic: how is it that tense features may in some cases be present

morphosyntactically, but have no semantic import? While the notion of 'agreement' has often been used to account for the phenomenon, there has not (to my knowledge) been any successful attempt to *reduce* SOT to mechanisms of feature transmission that are motivated elsewhere in the grammar. There is a clear *attempt* at unifying Sequence of Tense with some analogous phenomena in the pronominal domain in Kratzer 1998, but as we saw in Chapter 3 the pronominal part of her generalization is rather questionable (we will see below that the temporal part is also weak - which is a good thing, for this will allow us to suggest that Kratzer might be wrong in the *same* way for pronouns and for tense, which would preserve her basic intuition).

Some developments that are apparently considered important in the SOT literature are the following:

A. First, the necessity of a 'Sequence of Tense' rule was demonstrated by the failure of a simple and appealing theory, which says in essence that past tense morphemes are always interpreted, and always mean something like 'before x', where x is the 'anchor' of the past tense. A version of this account is presented in Enç 1987's referential theory of tense. The attempt was shown to be doomed by the following type of examples, due to Kamp & Rohrer 1984:

(34) Yesterday John decided that tomorrow at lunch time he would tell his mother that they WERE having their last meal together.

Since the meal is taking place 'tomorrow', it could not possibly be *before* any time introduced in the previous discourse, which shows that in this case past tense on 'were' does not contribute any meaning of anteriority.

B. Since tenses are not always interpreted, some Sequence of Tense rule must be posited in *some* cases. The question is to know which, and why.

Abusch argued in Abusch 1997 (and earlier work) that it was only in intensional environments that a morphological rule was needed (the technical version of her proposal is discussed below). We essentially agree with her characterization of the problem, and use a variant of her semantics for tense, with the notational difference that the time coordinate of an embedded context is called in her system a 'now' parameter. Unfortunately when it comes to explaining the morphosyntactic aspect of the SOT problem, Abusch simply stipulates an entire system of feature transmission in the syntax, with no attempt to relate it to any mechanism known from other domains of the grammar. Thus the morphosyntactic part of her theory is entirely *ad hoc*. One consequence of this is that in complex cases her system makes subtly different predictions from the theory that falls out of the tense/person analogy. But even if this were not the case (i.e. if the two theories were extensionally equivalent), her system would be highly undesirable on the ground that its morphosyntactic part is so utterly stipulative.

C. Ogiwara 1996 also argued for a Sequence of Tense rule. His system, devised to account for the contrast between English and Japanese, relies on a mechanism that can optionally apply in English (though not in Japanese) to delete a tense that appears under another tense with identical features (the rule can only apply within a local domain). In case a tense is deleted, the corresponding time variable gets bound by an

abstractor in the most local Comp. Unlike Abusch, Ogihara assumes that the rule can apply both in intensional and in extensional contexts. But for present purposes the important point is that, like Abusch, Ogihara fails to relate his 'deletion rule' to any other grammatical phenomenon.

At this level of generality, one might think of Ogihara's 'deletion rule' as another way of stating what we have assumed all along, namely that some features arise through agreement in the syntax, and are ignored at LF: we say that features 'are there' but can be ignored; Ogihara says that they get 'deleted' at LF. But apart from terminology, there is no difference at this point. However given the way Ogihara set up his formal system, a notion of locality was built into tense deletion: in his system tense deletion can occur only *locally*. Correspondingly, the variable that corresponds to a deleted tense must be bound by an abstractor in the closest Comp position. This could be an interesting move if (i) he could connect the conditions on tense deletion to some analogous morphosyntactic phenomenon elsewhere in the grammar, and if (ii) he gave arguments for the locality conditions. But unfortunately he does neither.

(iii') What about locality, then? First, observe that from our perspective there is no reason morphosyntactic agreement should be constrained by locality. In fact when we discussed Kratzer's claim in Chapter 3 we observed that this was precisely *not* the case, since 1st person features could be copied long-distance even when it was clear that the features of the lower pronoun were not interpreted:

(35) Only I was vain enough to believe that Mary would come if I invited her.
 [Only I] λx x was vain enough [to believe [that Mary would come [if x invited her]]]

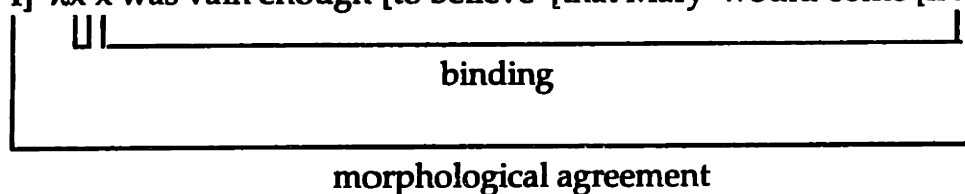

It is of course the case that there are pronominal elements that are constrained by locality - for instance PRO. And of course PRO must inherit features from an antecedent, which must therefore appear locally. So it *could* be that tenses are like PRO rather than like 'I'. This is not the Null hypothesis, however. If this were the case one would have to ask why both 'PRO' and 'I' should exist in the person domain, even though only the equivalent of PRO exists for tense. But this would certainly be an interesting discovery.

Unfortunately, as far as I can tell no argument was provided in Ogihara's book for the locality of the 'tense deletion rule'. As a matter of logic, the claim cannot be supported unless some examples are provided that contain two levels of embedding, and are for that reason ungrammatical. But there are no such examples in Ogihara 1996. On the other hand there are interesting arguments for the locality of SOT in Hornstein 1990 - but Ogihara does not discuss Hornstein's work in this context. The topic of Locality of Sequence of Tense is taken up at the end of this section.

2.2. The Null Hypothesis: Sequence of Tense = Sequence of Person

Building from the Null Hypothesis, we follow the same format of discussion as we did for Person. We start with the contrast between the English and the Russian

present tenses, and then study the mechanism of agreement which is needed to account for cases in which tense features are not interpreted.

2.2.1. English Present vs. Russian Present

In the person domain, the basic contrast between English and Amharic 1st person pronouns had been captured by postulating that English 'I' is unambiguously specified for a feature λ , while Amharic 'I' has two homophonous entries, with one specified for λ , while the other is specified for λ . It was also understood that homophony was probably not the right way to handle the phenomenon, and that in the end a further decomposition might be needed, with $\lambda = [a, +matrix]$ and $\lambda = [a, -matrix]$. In simple cases [i.e. those that involve neither Free Indirect Discourse nor 'only' or attitude operators], λ forced a variable to be bound by the author coordinate of the matrix context, while λ forced binding by the author coordinate of an embedded context. Exactly the same device can be used for Tense: the English present is only specified for \uparrow , so that in simple cases it must be bound by the time coordinate of the matrix context. By contrast, the Russian present may be specified either for \uparrow or for \downarrow , which allows it to be bound by the time coordinate of an embedded context. To summarize:

- (36) Present
 a. English: /PRES \uparrow /
 b. Russian: /PRES_{Rust}/, /PRES_{Rust} \uparrow /

We will later assume that the English past is specified for the features \langle, \uparrow (= obviative present), while the English pluperfect has a specification for $\langle, \langle, \uparrow$ (= further obviative)⁸¹:

- (37) Past Tenses in English
 /PAST \langle, \uparrow /, /PAST $\langle, \langle, \uparrow$ /

- The English present cannot be shifted for exactly the same reason as in the case of the English 1st person pronoun: it can only be specified for a feature \uparrow which does not appear on the embedded variable, so that the item cannot be inserted:

- (38) a. #John_i says that I_i am a hero (intended reading: John_i says that he_i is a hero)
 b. C* λC John_i says ... that $\lambda \langle x^{\lambda \uparrow}, \dots \rangle x^{\lambda \uparrow} / I_i /$ be a hero ...
 [The derivation is ruled out in the morphological component, since λ is not among the features that appear on the embedded variable]

- (39) a. #Peter said (a year ago) that Mary is pregnant
 b. Shifted reading with /PRES \uparrow /: morphologically ill-formed
 C* λC P. says at t^{Past} ... that $\lambda \langle \dots t^{\lambda \text{Past}} \rangle > M.$ be-pregnant at $t^{\lambda \text{Past}} / \text{PRES}_{\text{Rust}} /$

[The derivation is ruled out in the morphological component, since \mathfrak{a} is not among the features that appear on the embedded variable]

• Similarly, the Russian present can be shifted in exactly the same way as the Amharic 1st person pronoun. Consider again our final analysis of the shifted reading of Amharic 'I':

(40) john Jägna näNN yt-lall [Amharic]
John hero I-am says-3 sg.m

a. Embedded reading with $/I_{\text{Amh}\mathfrak{a}}/$: well-formed? [the ' \mathfrak{a} ' option is chosen]

$C^* \lambda C$ John ^{$\mathfrak{3}$} says ... that $\lambda < x^{\mathfrak{3}\mathfrak{3}}, \dots > x^{\mathfrak{3}\mathfrak{3}} / I_{\text{Amh}\mathfrak{a}}/$ be a hero ...

b. Embedded reading with $/he_{\text{Amh}\mathfrak{h}}/$: well-formed?

$C^* \lambda C$ John ^{$\mathfrak{3}$} says ... that $\lambda < x^{\mathfrak{3}\mathfrak{3}}, \dots > x^{\mathfrak{3}\mathfrak{3}} / he_{\text{Amh}\mathfrak{h}}/$ be a hero ...

There were two parts to the final analysis.

(i) First, we wanted to make sure that $/I_{\text{Amh}\mathfrak{a}}/$ could in principle be inserted to spell-out the embedded variable, i.e. that its features were a subset of those that appear on $x^{\mathfrak{3}\mathfrak{3}}$. This was indeed the case since $x^{\mathfrak{3}\mathfrak{3}}$ was bound by the author coordinate of an embedded context, and was thus forced to bear a feature \mathfrak{a} .

(ii) Second, we had to ensure that no other item which was more highly specified than $/I_{\text{Amh}\mathfrak{a}}/$ could be inserted. While no other Amharic item had strictly more features than \mathfrak{a} , it was plausible to think that Amharic 'he', with the feature $\mathfrak{3}$, was equally highly specified as $/I_{\text{Amh}\mathfrak{a}}/$. We were forced to stipulate that in such cases Universal Grammar prefers to express \mathfrak{a} over $\mathfrak{3}$ in order to block in the morphological component the derivation in b. above.

The same logic applies to the shifted reading of a Russian present tense embedded under an attitude verb in the past. All we claim to accomplish here is to explain why the present tense morpheme can in principle be inserted, i.e. why its features are a subset of those that appear on the variable in the syntax. The second part of the morphological task would be to explain why it *must* be inserted, i.e. why it is more highly specified than its competitors. Here things are more problematic than in the person case, and we will leave this as an open problem. [For the moment, we abbreviate the past tense features $< \mathfrak{P} /$ as *Past*]

(41) pjetja skazal, Cto miSa plaCet [shifted reading]
Pjetja said that Misha is-crying

a. Simultaneous reading with $/PRES_{\text{Rus}\mathfrak{t}}/$ well-formed?

$C^* \lambda C$ P. says at t^{Past} ... that $\lambda < \dots t^{\text{Past}} \dots > M.$ cries at $t^{\text{Past}} / PRES_{\text{Rus}\mathfrak{t}}/$

b. Simultaneous reading with $/PAST_{\text{Rus}\mathfrak{t}}/$: well-formed?

$C^* \lambda C$ P. says at t^{Past} ... that $\lambda < \dots t^{\text{Past}} \dots > M.$ cries at $t^{\text{Past}} / PAST_{\text{Rus}\mathfrak{t}}/$

(i) As in the Person case, it is clear why /PRES_{Rusl}/ can in principle be inserted: the embedded time variable is bound by the time coordinate of the embedded context, and it thus inherits a feature *t*

(ii) The analysis of the competition procedure involves some difficulties. At this point it looks like we could use the same stipulation as in the Person case ('express *t* rather than *Past*'), but in fact when the unabbreviated notation is used further problems arise, which we leave for future research.⁸²

2.2.2. Sequence of Tense in English

How does English spell-out the logical form which is pronounced with a shifted present tense in Russian? With an embedded past tense whose features remain uninterpreted. The same question had arisen in the Person domain: English could not use a 1st person to pronounce what was spelled-out in Amharic as (literally) 'John_i says that I_i am a hero'. The pronoun 'he' had to be used in English for the embedded De Se pronoun. This was not a problem given the rules for feature transmission that we had posited for Attitude operators: a variable could be bound by a coordinate of an embedded context, but still inherit the features of an element of the superordinate clause. And since these features were the result of agreement, they remained uninterpreted⁸³:

- (42) a. Smith hopes that he is elected
 a'. $C^* \lambda C \text{ Smith}^{i\#} \text{ hope ...that } \lambda \langle x^{i\#} \dots \rangle x^{i\#} / \text{he}_{i\#} / \text{ be elected ...}$
- b. Mary hopes that she is elected
 b'. $C^* \lambda C \text{ Mary}^{i\#} \text{ ...that } \lambda \langle x^{i\#} \dots \rangle x^{i\#} / \text{she}_{i\#} / \text{ be elected ...}$
- c. You hope that you are elected
 c'. $\langle \dots Y^{i\#} \dots \rangle \lambda \langle \dots Y^{i\#} \dots \rangle Y^{i\#} \text{ hope ...that } \lambda \langle x^{i\#} \dots \rangle x^{i\#} / \text{you}_{i\#} / \text{ be elected ..}$
- d. I hope that I am elected
 d'. $\langle X^{i\#} \dots \rangle \lambda \langle X^{i\#} \dots \rangle X^{i\#} \text{ hope ...that } \lambda \langle x^{i\#} \dots \rangle x^{i\#} / I_A / \text{ be elected ...}$

Exactly the same logic can be applied to Tense. An embedded time variable inherits the features of the tense of the matrix clause. These features remain uninterpreted, but can be spelled-out in the morphological component. This is just what Sequence of Tense is in English (we consider only the De Se reading at this point; cf. below for the De Re reading):

- (43) a. Peter said (a year ago) that Mary was pregnant [Simultaneous Reading, De Se]
 b. $C^* \lambda C P. \text{ says at } t^{Past} \dots \lambda \langle \dots t^{Past} \dots \rangle M. \text{ be-pregnant at } t^{Past} / \text{PAST}_{Past} /$

This, of course, is an abbreviation, since we have written *Past* for \langle, \uparrow , and have omitted from the representation the presuppositions contributed by the past tense of the matrix

clause. A fuller representation is the following (for clarity, we leave out individual and world variables):

- (44) $\langle \dots T^{\uparrow} \dots \rangle \lambda \langle \dots T^{\uparrow} \dots \rangle$ P. says at $t^{\langle \uparrow \rangle} [t^{\langle \uparrow \rangle} < T^{\uparrow}] \dots$
 $\lambda \langle \dots t^{\langle \uparrow \rangle} \rangle$ M. be-pregnant at $t^{\langle \uparrow \rangle} / \text{PAST}_{\langle \uparrow \rangle} / \dots$

It should be noted that in English and in French the decompositional analysis of the past tense does not seem to bring very much in simple Sequence of Tense environments. Although the analysis claims that the features \langle and \uparrow are present in the embedded clause, they never get spelled-out separately, i.e. with a present tense auxiliary to express \uparrow , and a past participle to express \langle . But apparently in some languages a periphrastic past *can* be used in Sequence of Tense environments. Preliminary work suggests that this is optionally the case in Upper Austrian [in other words, both the SOT and the non-SOT option are available in Upper Austrian for present-in-the-]:

- (45) Present-in-the-past: optional Sequence-of-Tense [M. Hackl, p.c.]

a. 10 years ago he said: 'Ich arbeite für BayBank' ['I work for BayBank']
 [note: BayBank doesn't exist any more, so a double-access reading doesn't make sense in this situation]

b. Vor zehn Jahren hat er mir gesagt, daß er für BayBank arbeitet.
Before ten years has he to-me said that he for BayBank works
 'Ten years ago he told me that he worked for BayBank'

c. Vor zehn Jahren hat er mir gesagt, daß er für Baybank gearbeitet hat.
Before ten years has he to-me said, that he for BayBank worked has
 'Ten years ago he told me that he worked for BayBank'.

Presumably the difference between English or French and Upper Austrian is related to the fact that the periphrastic past is the only past tense there is in the latter, though not in the former languages. It is not clear how this should be derived.

2.2.3. De Se vs. De Re: the De Se - Indexicality Generalization

As was mentioned at the outset, the De Se / De Re distinction in the temporal domain is not particularly well argued for, and the crucial judgments are not particularly clear. Still, we present the logic of a test for the De Se - Indexicality generalization, since this is a fine-grained semantic prediction which we have seen at work with temporal adverbials and with pronouns. The prediction is that a shifted present under a past tense verb in a non-SOT language should be exclusively read De Se, since its feature content forces it to be bound by the time coordinate of the embedded context. By contrast, English 'was' should be read either De Re or De Se, since it can either be anaphoric to the time coordinate of the embedded context *or* to the matrix tense. Here, then, are the predictions:

(46) Non-SOT languages

lit. Pjetja said that Misha is crying

a. Ok Simultaneous Reading, De Se

C* λC P. says at t^{Past} ... that λ<... $t^{λPast}$... > M. cries at $t^{λPast}$ /PRES_l/

b. # Simultaneous Reading, De Re

C* λC P. says at t^{Past} ... that λ<... $t^{λPast}$... > M. cries at t^{Past} /PRES_l/

This derivation is presumably blocked in the morphological component - the Russian past tense must be inserted whenever the features *Past* appear on a variable (but see the discussion in fn. 11)

(47) SOT languages

Peter said (a year ago) that Mary was pregnant [Simultaneous Reading, De Se]

a. Ok Simultaneous Reading, De Se

C* λC P. says at t^{Past} ... λ<... $t^{λPast}$ > M. be-pregnant at $t^{λPast}$ /PAST_{Past}/

b. Ok Simultaneous Reading, De Re

C* λC P. says at t^{Past} ... λ<... $t^{λPast}$ > M. be-pregnant at t^{Past} /PAST_{Past}/

In order to test the prediction, our strategy has been to compare the SOT and the non-SOT option in Modern Greek, a language which (like Upper Austrian) allows for both possibilities for present-in-the-past. The prediction is of course that the non-SOT option, i.e. the one that involves an embedded indexical, should only have a De Se reading, while the anaphoric option should yield both a De Se and a De Re reading. In English, a non-SOT option is not available. However in order to get comparative judgments we have tried to contrast the SOT option with a synonymous sentence involving an infinitive structure, with the hope (already expressed before) that embedded tense might be unambiguously De Se. This seems to be correct, since the infinitive structure appears to disallow the De Re reading. However the following judgments should be considered with extreme caution given the difficulty of the task.

(48) Modern Greek (Sabine Iatridou, p.c.)

Scenario: On Tuesday, Petros read a chart and said: 'The doctor on duty on Tuesday was Kostas'. Of course Petros was mistaken about that day's date - he mistakenly thought it was already Thursday.

- | | | |
|--------------------------|------------|--|
| a. tin proigumeni triti | o Petros | ipe otti o Kostas itan o iatros ipiresias |
| the last Tuesday | the Petros | said that the Kosta was the doctor on-duty |
| b. *tin proigumeni triti | o Petros | ipe otti o Kostas ine o iatros ipiresias |
| the last Tuesday | the Petros | said that the Kosta is the doctor on-duty |

In a more 'normal' situation where Petros said on Tuesday: 'Kostas is on duty today', both sentences become grammatical.

(49) English: both a 'de se' and a 'de re' reading (?) (D. Embick, p.c.)

Scenario: On Tuesday, Mary read a chart that read: 'Tuesday - doctor on duty: John'. However Mary mistakenly thought that that day's date was Thursday.

- a. #On Tuesday Mary believed John to be the doctor on duty
- b. On Tuesday Mary believed that John was the doctor on duty

2.2.4. Past Tense vs. Pluperfect

The system developed so far makes an uncommon prediction. It is typically assumed (e.g. in Ogihara 1996 and Abusch 1997) that a past tense can *always* be used with a backward-shifted reading, independently of the tense of the matrix verb. The situation is slightly different within our system. Consider the following example:

- (50) a. **Situation:** John said: 'Clinton has resigned'
 - b. **Report:** John said that Clinton had resigned
 - c. $\langle \dots T^{\uparrow} \dots \rangle \lambda \langle \dots T^{\uparrow} \dots \rangle$ J. says at $t^{\langle, \uparrow} [t^{\langle, \uparrow} < T^{\uparrow}] \dots$
 $\lambda \langle \dots t^{\langle, \uparrow} \dots \rangle$ Clinton resigns at $t^{\langle, \uparrow} [t^{\langle, \uparrow} < t^{\langle, \uparrow}] \dots$
- or in a more standard notation (one without diacritics):
- c'. $\langle \dots T^* \dots \rangle \lambda \langle \dots T \dots \rangle$ J. says at $t_1 [t_1 < T]$...
 - $\lambda \langle \dots t_2 \dots \rangle$ Clinton resigns at $t_3 [t_3 < t_2]$

In this situation John's claim is that Clinton resigned at some point before (what John believes to be) the time of his speech act. It would thus be natural to report this by using a logical form as in c., where the anchor of the embedded time variable is the time coordinate of the reported speech act. But this implies that the embedded variable cannot be spelled-out with a simple past, but only with a pluperfect. Here is why.

The time coordinate of the embedded context bears the features \downarrow (because it is the coordinate of an embedded context), as well as $<$ and \uparrow (by agreement with the tense of the matrix verb). But if the logical form is to encode the fact that the embedded time variable takes the time coordinate of the embedded context as its *anchor*, the variable must bear an interpretable feature $<$ (which triggers the appearance in the logical form of the relevant presupposition). The variable bears the tense features of its anchor, as well as the interpretable feature. In total, it must thus bear the features: $<, <, \downarrow, \uparrow$. As a result, the pluperfect, specified as $/PLUP_{<, <, \uparrow}/$ will win in the competition procedure over $/PAST_{<, \uparrow}/$. Which means that a. above can only be reported with b., not with 'John said that Clinton resigned'.

The problem is that very often one can say both. Thus in the foregoing example it wouldn't be particularly odd to report John's claim with: 'John claimed that Clinton resigned'. The reason is presumably that an alternative logical form can be used to do the reporting, in which the embedded variable is anchored to the time coordinate of the matrix context:

- (51) $\langle \dots T^{\uparrow} \dots \rangle \lambda \langle \dots T^{\uparrow} \dots \rangle$ J. says at t_1 [$t_1^{\uparrow} < T^{\uparrow}$] ...
 $\lambda \langle \dots t^{\uparrow} \dots \rangle$ Clinton resigns at t_3 [$t_3^{\uparrow} < T^{\uparrow}$] ...

or without diacritics:

- (51') $\langle \dots T^* \dots \rangle \lambda \langle \dots T \dots \rangle$ J. says at t_1 [$t_1 < T$] ...
 $\lambda \langle \dots t_2 \dots \rangle$ Clinton resigns at t_3 [$t_3 < T$] ...

In this logical form the time of Clinton's resignation is presupposed to be before the time of the actual speech act. In the previous logical form, it was supposed to be before (what John took to be) the time of John's utterance:

- (52) $\langle \dots T^* \dots \rangle \lambda \langle \dots T \dots \rangle$ J. says at t_1 [$t_1 < T$] ...
 $\lambda \langle \dots t_2 \dots \rangle$ Clinton resigns at t_3 [$t_3 < t_2$] ...

Sometimes one can use either logical form. But there are cases in which a difference between the two logical forms might be easier to see. Consider the following situation:

(53) **Situation:** Until yesterday Pierre believed we were already in year 2003. If he had been asked, he would have assented to the following: 'Clinton left office in year 2000'.

- (i) a. Jusqu'à hier Pierre croyait que Clinton avait quitté la présidence en 2001
 b. ?? Jusqu'à hier Pierre croyait que Clinton a quitté la présidence en 2001
 a'. Jusqu'à hier Pierre croyait que Clinton avait été élu en 1993
 b'. (?) Jusqu'à hier Pierre croyait que Clinton a été élu en 1993
- (ii) a. Until yesterday Peter believed that Clinton had left office in year 2001
 b. #Until yesterday Peter believed that Clinton left office in year 2001
 <a'. Until yesterday Peter believed that Clinton had been elected in 1993>
 <b'. Until yesterday Peter believed that Clinton was elected in 1993>

Using a simplified notation (without diacritics), here is how our theory handles these examples:

- (53) a. Peter believed that Clinton HAD left office in year 2001
 $\langle \dots T^* \dots \rangle \lambda \langle \dots T \dots \rangle$ P. believes at t_1 [$t_1 < T$] ...
 $\lambda \langle \dots t_2 \dots \rangle$ Clinton leaves office at t_3 [$t_3 < t_2$] & $t_3 = 2001$...
- b. #Peter believed that Clinton left office in year 2001
 $\langle \dots T^* \dots \rangle \lambda \langle \dots T \dots \rangle$ P. believes at t_1 [$t_1 < T$] ...
 $\lambda \langle \dots t_2 \dots \rangle$ Clinton leaves office at t_3 [$t_3 < T$] & $t_3 = 2001$...

(a) is unproblematic: since Peter is mistaken about the time, it is indeed the case that the time at which he *thinks* his thought act is taking place ($=t_2$) is *after* year 2001, and therefore the condition ' $[t_3 < t_2]$ & $t_3 = 2001$ ' does not cause any problem. By contrast, (b) yields an odd result when lambda-conversion is applied :

(54) Clinton leaves office at t_3 [$t_3 < T^*$] & $t_3 = 2001$

If $T^* = 1999$, the condition imposes contradictory requirements on t_3 , whose value must be both before the time of the actual utterance (1999) and after 2001. This is presumably the source of the contrast between a. and b.

Maybe a clearer example is provided by cases that involve a shifted past tense under 'would':

(55) **Situation:** Peter will be promoted tomorrow morning. And he knows that, as usual, his mother will learn the news before he announces it to her.

a. Yesterday Peter told me that tomorrow at lunch time his mother would already know that he HAD BEEN promoted in the morning [i.e. in the morning before their conversation]

b. #? Yesterday Peter told me that tomorrow at lunch time his mother would already know that he was promoted in the morning [i.e. in the morning before their conversation]

(55') a. Hier Pierre m'a dit que demain au moment du déjeuner sa mère saurait déjà qu'il avait été promu le matin même.

b. #Hier Pierre m'a dit que demain au moment du déjeuner sa mère saurait déjà qu'il a été promu le matin même.

The most deeply embedded tense is anchored to an element with past tense features (since 'would' is the past tense form of 'will'), and therefore it should appear in the syntax with pluperfect features - which should get reflected in the morphology since English had the means to express this. A past tense, by contrast, should be interpreted as 'past relative to the actual speech time', which should contradict the fact the time of the promotion is in our future. This appears to account for the deviance of the b. examples (although one would wish that the contrasts were stronger).

No such prediction is made by theories that allow a past tense to be anchored to the time coordinate of *any* embedded context, independently of the tense of the attitude verb. This is in particular the case of Abusch's theory, which stipulates the following rules of feature transmission:

(56) Abusch's Theory of Sequence-of-Tense [Abusch 1997 p. 31]

"(i) All temporal arguments (not only tenses, but also covert arguments of nominals such as 'desire') are supplied with a relation variable relating their index to local evaluation time, as determined in LF.

(ii) An intensional operator such as 'believe' or 'desire' transmits the relation associated with its temporal argument to its intensional argument by a feature passing mechanism. Such relations are cumulative

down the tree, so that a tense embedded in an intensional context has access to a set of temporal relation variables.

(iii) The semantics of tense is a constraint on a set of temporal relations, consisting of the local relation together with transmitted relations. For past tense, the constraint is that at least one of the relations must be the temporal precedence relation⁸⁴

The important point is that in Abusch's system the condition for the appearance of a past tense is that 'at least one' of the temporal relations a time variable has access to should be the precedence relation [(iii)]. The condition is trivially satisfied for any sort of backward shifted reading, and in particular in the cases which, according to us, *must* involve a pluperfect. Thus Abusch's system appears to be too liberal. It could be improved by stating the constraint as requiring that *exactly one* of the relations must be temporal precedence (but this would be just another stipulation; what is needed is a mechanism that derives the correct rule from a principled account of feature transmission).

2.2.5. Structure

As was mentioned earlier, the discussion of Sequence of Tense is commonly framed in terms of locality. We believe the assumption to be rather questionable: if tenses behave like pronouns, there is no reason they should by definition be constrained by locality. Maybe *some* temporal pronouns are so constrained, but there is no reason to build this in the system. We now consider possible arguments for a locality condition on Tense agreement / tense deletion, and suggest that they are not strong.

a) c-command

Ogihara 1989/1996 suggested that Tense deletion could apply only in case a tense was c-commanded (locally) by another tense with identical features. However in the course of the discussion in Ogihara 1996, the c-command condition is weakened because of the following examples, due to I. Heim (Ogihara 1996 (64a-c) p. 132):

- (57) a. John's (earlier) claim that he was innocent is well-known.
b. I still recall John's public announcement that he had cancer
c. This contradicts John's (earlier) claim that Mary would win the prize

In these examples there is no overt tense to trigger tense agreement (i.e., in Ogihara's terms, tense deletion), and therefore the c-command condition is violated. Similar facts hold of Person, as was mentioned in Chapter 3:

- (58) a. <Talking about the murderer> The desire PRO to be recognized for the genius he really was was too overwhelming. <John turned himself in.>
a'. Le désir d'être reconnu pour ce qu'il était, un génie du crime, était trop fort. <Jean se dénonça.>
b. <John Smith, a former candidate, looks back> In retrospect, the hope that he would be elected was utterly groundless.
b'. L'espoir qu'il serait élu avait été, en définitive, sans le moindre fondement.

In our treatment there is no c-command condition on tense agreement. Consider again our statement of formation rule for attitude operators:

(59) If ϕ is a well-formed formula and if ATT is an attitude operator,

$ATT(x^{\mathfrak{d}}, (y^{\mathfrak{e}}), t^{\mathfrak{f}}, w^{\mathfrak{g}}) \lambda \langle x^{\mathfrak{d}}, (y^{\mathfrak{e}}), t^{\mathfrak{f}}, w^{\mathfrak{g}} \rangle \phi$ is a well-formed formula.

[where $\mathfrak{d}, \mathfrak{e}, \mathfrak{f}, \mathfrak{g}$ stand for the set of all features that appear on $x, y, t,$ and w respectively]

While the rule constrains the way in which morphosyntactic features are transmitted, it is in a crucial respect semantically based: the features that get transmitted are those that appear on the semantic *arguments* of the attitude operator, independently of their position in the syntactic structure. Thus for a thought act the author coordinate of the embedded context inherits the features of the thinker, the time coordinate those of the time of thought, etc.

As long as attitude operators like 'claim' or 'desire' can be represented in the logical syntax with a 'thinker' and a time arguments, the general agreement rule for attitude operators can apply in the same way as it does when overt agent and time arguments are represented in a superordinate clause.

b) Locality of binding and locality of tense deletion

Two additional locality conditions are often assumed to constrain the interpretation and the morphosyntax of tense. One of them is a red herring, while the other is hard to test, and probably incorrect.

(i) Locality of Binding: von Stechow's 'Abusch's Constraint'

Von Stechow 1995 suggests that a temporal argument that appears in an attitude environment must always be read De Se. In our terms, it must be bound by the time coordinate of the closest context variable. Von Stechow calls this 'Abusch's constraint', and states it as an injunction that there be 'no free tense' in attitude environments (these he calls 'strong intensional contexts' [p. 372]. The constraint reads: 'No free tense in strong intensional contexts!' [p.372]).

[The appeal of the constraint might be to account for examples such as the following:

- (i) Peter believed that Mary left
 - a. Ok Peter believed that Mary left at some point before (what he thinks is) the time of his belief
 - b. #Peter believed that Mary left at some point after (what he thinks is) the time of his belief [=Peter believed that Mary WOULD leave]

b. is a 'forward shifted' reading, which is markedly deviant. Given some constraints on the syntax of tense, one could imagine that b. would be blocked because it would result from a configuration in which a variable is free in the scope of attitude operator, while this wouldn't hold of a.:

- (ii) a. $\exists t < T^*$ [Peter believes at t that $\exists t' t' < T^*$ Mary leaves at t']
 b. $\# \exists t < T^* \exists t' t' < T^*$ [Peter believes at t that Mary leaves at t']

Abusch introduced a special constraint, which she calls the 'Upper Limit Constraint' to rule out examples like a. (see Appendix for a discussion). But that constraint has nothing to do with free variables in the scope of attitude operators, and it is hard to see how it could be reduced to von Stechow's 'Abusch's constraint'. Certainly von Stechow 1975 doesn't claim to achieve such a reduction.]

The constraint can easily be misconstrued as preventing a tense from ever being read De Re in an attitude environment. But in von Stechow's system this is not so. ~~The crux of the matter is that he allows tenses to be syntactically moved outside the scope of an attitude operator, and to be thus read De Re - an assumption shared by Abusch and Ogihara.~~ The process is somewhat complicated, and irrelevant for our purposes⁸⁵. The point is that von Stechow, Abusch and Ogihara get through syntactic movement what we achieve by leaving *in situ* a variable which is bound from outside the attitude operator. Following Kaplan's work on 'Quantifying In', we assume that logical forms with a free variable under an attitude operator are perfectly well-formed, although their *interpretation* requires non-standard rules that involve acquaintance relations and a notion of 'vividness', as was briefly discussed in Chapter 2. A further question would be whether there is any evidence for a movement analysis of De Re readings⁸⁶.

(ii) Locality of Tense Deletion: Ogihara's Condition

It has often been suggested that Tense Deletion (in our terms: tense agreement) is constrained by Locality. Ogihara 1996 suggests that his Tense Deletion rule can apply only locally: a tense feature may be deleted only if no other tense feature intervenes between the trigger and the target of the deletion⁸⁷. The semantic side of Tense Deletion is that a time variable whose tense feature has been deleted gets bound by a λ -abstractor in the *closest* Comp. It should be observed that for us, just as for Ogihara, the syntactic side and the interpretive side of tense agreement are tightly connected. In our system, a coordinate of a context variable always inherits the features of an argument of the attitude verb that binds it. In Ogihara's system, the relation is less direct, but since both tense deletion and binding are assumed to be local, the result is the same.

In simple cases Ogihara's mechanism of Tense deletion has the same effect as the rule of feature transmission that was posited for attitude environments:

- (60) a. Ogihara's Tense Deletion Rule
 1. Syntax: John said that Mary was pregnant
 2. LF: John Past say that Mary \emptyset pregnant
 3. Interpretation: $\exists t [t < T^* \ \& \ \text{say}'(t, j, \lambda w \lambda t \lambda x [\text{be-pregnant}'(t, m, w)])]$
- b. Feature Transmission
 1.-2. Syntax/LF: $\langle \dots T^{\uparrow} \dots \rangle \lambda \langle \dots T^{\uparrow} \dots \rangle \exists t^{\langle \uparrow \rangle} J. \text{ says at } t^{\langle \uparrow \rangle} [t^{\langle \uparrow \rangle} < T^{\uparrow}] \dots$
 $\lambda \langle \dots t^{\langle \uparrow \rangle} \dots \rangle M. \text{ be-pregnant at } t^{\langle \uparrow \rangle} \dots$
 3. Interpretation: $\exists t [t < T^* \ \& \ \text{say}'(t, j, \lambda \langle x, t, w \rangle [\text{be-pregnant}'(t, m, w)])]$

As can be seen, in this case the two mechanisms are equivalent. But in more complex situations, this is not so: in our system feature transmission in the syntax can be long-distance, and similarly time variables can be bound irrespective of the degree of embedding:

- (61) $\langle \dots T^{\uparrow} \dots \rangle \lambda \langle \dots T^{\uparrow} \dots \rangle \exists t^{\langle \uparrow \rangle} J. \text{ says at } t^{\langle \uparrow \rangle} [t^{\langle \uparrow \rangle} < T^{\uparrow}] \dots$
 [[[[any number of embeddings
 $[\lambda \langle \dots t^{\langle \uparrow \rangle} \dots \rangle M. \text{ be-pregnant at } t^{\langle \uparrow \rangle} \dots]]]]]$

Ogihara's Tense Deletion system is of course different in this respect: tense deletion and, correspondingly, binding of a variable whose features have been deleted, can only occur locally.

As far as I can tell Ogihara 1996 does not provide any argument for the locality condition. This is surprising since Hornstein 1990, who proposed a similar condition, does provide some empirical support for his theory. We discuss two cases in which the locality condition is undesirable, one in which it might be correct (Hornstein's example), and one in which it is correct but orthogonal to the issue at hand (the tense of an infinitive verb seems to be bound locally).

a. Relative clauses in attitude environments.

It is relatively well-known that definite descriptions must sometimes be allowed to take scope *in situ*, for otherwise their movement would violate island constraints (see for instance Heim 1991). What is interesting is that in such cases tense agreement and binding, i.e. in Ogihara's terms Tense Deletion, can be triggered non-locally:

(62) Being of a playful nature, I decided that tomorrow at lunch time I would tell my mother the following: 'My doctor claimed that if one eats what you are ordering, one gets sick'.

a. Yesterday I decided that tomorrow at lunch time I would tell my mother that my doctor had claimed that if one ate what she was ordering one got sick.

b. Hier j'ai décidé que demain au moment du déjeuner je dirais à ma mère que mon médecin avait prétendu que si l'on mangeait ce qu'elle était en train de commander on tombait malade.

On the intended reading, the description 'what she was ordering' is outside the semantic scope of 'claim'. If movement were not constrained by islands, we could represent the intended reading as follows:

(63) Yesterday I decided that tomorrow at lunch time I would tell my mother that [what she was ordering]_i [my doctor had told me that if one ate e_i one got sick].

Furthermore since the time of the ordering is *after* all the moments mentioned in the previous discourse, it is clear that the past tense on 'was ordering' is the result of tense agreement. In Ogihara's terms, the past tense must be deleted at LF. But since the

description is trapped inside an island, the only representation Ogihara can get is the following:

(64) Yesterday I decided that tomorrow at lunch time I would tell my mother that my doctor had told me that if [[what she \emptyset be ordering]_i, one ate e_i] one got sick.

But this forces the time of the ordering to be interpreted as simultaneous with the time of my doctor's claim which is incorrect. The problem does not arise if tense agreement is allowed to be non-local.

b. Attitude verbs

There is another set of facts that suggests that Ogihara's locality condition is undesirable. As a preparation for the crucial data, consider the following examples, modeled after Higginbotham 1998:

- (65) a. Gianni will say that Maria is dancing well (right now) [Higginbotham's (29)]
 b. Tomorrow you will recognize that you are (now) being difficult
 c. Tomorrow everyone will know what you are doing right now.

The point of these examples is that on the only sensible reading the embedded present tense is bound by the time coordinate of the matrix context, as in the following (partial) representation:

(66) $\langle \dots T^{\uparrow} \dots \rangle \lambda \langle \dots T^{\uparrow} \dots \rangle \dots$ you will recognize ... $\lambda \langle \dots t^{\uparrow} \dots \rangle$ you be difficult at $T^{\uparrow} \dots$

In these cases embedded present tense is bound non-locally by the time coordinate of the matrix context. By themselves, these examples are not a problem for Ogihara's condition, since no Tense Deletion is involved here. But if we embed these examples under 'knew', things become different. The most deeply embedded tense will now be bound by the time coordinate of the context introduced by 'knew', and will thus inherit past tense features:

(67) During the discussion (a week ago) I knew that two days later you would recognize that you were being difficult

On a natural reading, the most embedded tense is bound by the time coordinate of the embedded context introduced by 'know', so that the past tense features must be inherited from the highest verb, 'know':

(68) $\langle \dots T^{\uparrow} \dots \rangle \lambda \langle \dots T^{\uparrow} \dots \rangle$ I knew at t_1 [$t_1 < T^{\uparrow}$] ...
 $\lambda \langle \dots t_2 \dots \rangle$... you would recognize ...
 $\lambda \langle \dots t_3 \dots \rangle$... you be difficult at t_2 ...

Unfortunately it is rather hard to prove that this reading *must* be available in this case, since the sentence also has a number of other readings as well. For instance, the past tense features of 'were being difficult' might *not* be the result of tense agreement, but rather be interpreted with respect to the time coordinate of the lowest context:

- (69) $\langle \dots T^{\uparrow} \dots \rangle \lambda \langle \dots T^{\uparrow} \dots \rangle$ I knew at t_1 [$t_1 < T^{\uparrow}$] ...
 $\lambda \langle \dots t_2 \dots \rangle$ > ... you would recognize ...
 $\lambda \langle \dots t_3 \dots \rangle$ > ... you be difficult at t_4 [$t_4 < t_3$] ...

The problem, then, is to *force* the tense of 'were difficult' to be bound by the time coordinate of the intermediate context, so that tense agreement and binding will be shown to occur non-locally.

A particular class of performative verbs enforce this. Consider the French verb 'emmerder'. As noted by O. Ducrot in class lectures, 'emmerder' has two uses. Standardly it is a colloquial (and rather impolite) version of 'annoy'. Thus if I say: 'Pierre emmerde Jean', it means simply means that Pierre is annoying Jean. But in addition 'emmerder' can be used in the 1st person with a different meaning: 'Je t'emmerde' means roughly 'Go to hell!', and seems to be synonymous with "Je te dis: 'Merde!'", literally: 'I tell you: 'Shit'', also something very impolite. The interesting observation is that this is possible only when 'emmerder' occurs in the 1st person *and* in the present tense. Compare the following:

- (70) a. Je t'emmerde
 Ok I annoy you
 Ok I send you to hell
- b. Pierre t'emmerde
 Ok Pierre annoys you
 ?/* Pierre sends you to hell⁸⁸
- c. Je t'ai emmerdé / Je t'emmerdais
 Ok I annoyed you
 *? I sent you to hell

Thus 'emmerder' has the reading 'send someone to hell' only when it appears in the present tense in direct discourse. Unsurprisingly, this reading is also available in reported speech, but only when the tense of 'emmerder' can be interpreted as simultaneous with the time of the saying event (presumably the tense can only be construed De Se):

- (71) a. Jean a dit à Marie qu'il l'emmerdait
 Ok Jean told Marie that he annoyed her
 Ok Jean told Marie that he sent her to hell
- b. Jean a dit à Marie que Pierre l'emmerdait
 Ok Jean told Marie that Pierre annoyed her
 ?/* Jean told Marie that Pierre sent her to hell
- c. Jean a dit à Marie qu'il l'avait emmerdée / qu'il l'emmerderait
 Ok Jean told Marie that he had annoyed her / that he would annoy her
 * Jean told Marie that he had sent her to hell / he would send her to hell

The idea, then, is that we can use 'emmerder' as a litmus test for a simultaneous reading. Now consider the following:

(72) Situation: Right before he died, my grandfather wrote the following at the beginning of his will:

a. Un jour, tout le monde saura que je vous emmerde.
One day, everyone will-know all that I you EMMERD-pres.

'One day, everyone will know that I send you to hell'

b. #? Un jour, tout le monde saura que je vous emmerdais
One day, everyone will know that I you EMMERD-ipf.

c. # Un jour, tout le monde saura que je vous ai emmerdés
One day, everyone will know that I you have EMMERD-past participle

Now suppose we want to report the situation in (72a):

(73) En 1979 mon grand-père a écrit qu'un jour tout le monde saurait qu'il
In 1979 my grandfather has written that one day everyone would know that he

nous emmerdait
us emmerd-ipf.

Given the constraints on the funny reading of 'emmerder', the time of 'emmerdait' in (73) must be simultaneous with the time of the writing [note that it could *not* be simultaneous with the time of the 'knowing', which is supposed to occur after my grandfather's death]. But this entails that the time variable of the lowest clause can be bound by the time coordinate of the context introduced by 'wrote', *despite the presence of an entire tensed clause in between.*

Unless Ogihara allows res-movement to be non-local, the only representation he can get for these examples is the following:

(74) 2. LF: My grandfather wrote that ... everyone would know that he EMMERD- \emptyset
us

As a result, 'emmerder' should be read as simultaneous with the time of the 'knowing', contrary to fact.

[And if Ogihara allowed res-movement to be non-local, we could still trap the tense of 'emmerdait' inside an island to make our point:

(75) En 1979 mon grand-père a écrit qu'un jour tout le monde serait conscient du
In 1979 my grandfather has written that one day everyone would be conscious of-the

fait qu'il nous emmerdait
fact that he us emmerd-ipf.

The tense of the embedded clause is inside a complex NP, and must thus remain there].

c. Hornstein's facts

Hornstein 1990 offers some empirical arguments to support the claim that Sequence of Tense can only apply locally. His first observation is that the following sentence lacks the reading indicated by the numbers:

- (76) #John said a week ago (= -7)
that Frank would believe in three days (= -4)
that Sam will /would be in London in two days. (= -5)
[Hornstein's (29) on p. 135]

Since we are not interested in all the other readings that Hornstein wanted to discuss, we can give a disambiguated version of his example:

(77) John said on Monday that Frank would believe on Thursday that Sam will / would be in London on Wednesday
Translated into our framework, Hornstein's claim is that the most deeply embedded tense cannot be anchored to the matrix tense (more probably, unless a De Re reading is intended, to the time coordinate of the intermediate context). But the argument is not convincing. Independently of Sequence of Tense phenomena, these sentences are awkward, as can be seen in unembedded examples

(78) #Frank will believe in three days that Sam will be in London in two days

(79) #Frank will believe on Thursday that Sam will be in London on Wednesday

It is not clear *why* these sentences should be deviant, but they seem to be. And that suggests that the problem noted by Hornstein in the embedded versions of these examples might have nothing to do with Sequence of Tense.

The second argument given by Hornstein is more convincing:

- (80) a. *John said that Harry believes that Frank would be here.
b. John said that Harry believed that Frank would be here.

We do not know why a. is deviant, and agree that it can be interpreted as an argument for Hornstein's Locality condition - a condition which, however, our previous examples seem to contradict. We leave a. as an open problem for the claim that there are no locality conditions on Sequence of Tense.

d. Locality with infinitives?

There might be a case in which binding of a time variable must indeed be local. Consider the following contrasts (D. Embick, p.c.):

- (81) a. ? Tomorrow you'll claim that you are not drunk right now
b. *Tomorrow you'll claim not to be drunk right now

It looks like the tense of an infinitive can only be bound by a local antecedent, which makes it impossible for it to be bound by the time coordinate of the matrix context. This is also consistent with the preliminary evidence we presented at the beginning of this chapter that the tense of an infinitive might be unambiguously De Se:

(82) Scenario: On Tuesday, Mary read a chart that read: 'Tuesday - doctor on duty: John'. However Mary mistakenly thought that that day's date was Thursday.

- a. #On Tuesday Mary believed John to be the doctor on duty
- <b. On Tuesday Mary believed that John was the doctor on duty>

These examples are parallel to, but considerably less clear than, the cases with PRO that were examined in Chapter 3. But if the facts are similar, the conclusion should be as well: the tense of an infinitive, just as its controlled subject when there is one, must be bound locally. But this might have nothing to do with attitudes or tense per se.

2.3. Summary of the rules

(83) If ϕ is a well-formed formula and if ATT is an attitude operator,

$ATT(x^{\mathfrak{d}}, (y^{\mathfrak{e}}), t^{\mathfrak{f}}, w^{\mathfrak{g}}) \lambda \langle x^{\mathfrak{h}}, (y^{\mathfrak{i}}), t^{\mathfrak{j}}, w^{\mathfrak{k}} \rangle \phi$ is a well-formed formula.

[where $\mathfrak{d}, \mathfrak{e}, \mathfrak{f}, \mathfrak{g}$ stand for the set of all features that appear on x, y, t , and w respectively]

(84) a. Inventory of features: Add <

b. Syntax

A variable or a constant of the form $t^{\mathfrak{d}}$ (with \langle in bold), where \mathfrak{d} is a set of tense features, is ill-formed unless immediately followed by $[t^{\mathfrak{d}} \langle \xi^{\mathfrak{d}}]$.

[In what follows we understand this well-formedness constraint as applying to variables that are not immediately adjacent to a λ -abstractor or a quantifier. Thus ' $\lambda t^{\mathfrak{d}} \dots t^{\mathfrak{d}} [t^{\mathfrak{d}} \langle \xi^{\mathfrak{d}}] \dots$ ' is well-formed]

c. Semantics

If s is an assignment, $[[t [t \langle t']]]_s = [[t]]_s$ if $[[t]]_s$ is prior to $[[t']]_s$
 Otherwise $[[t [t \langle t']]]_s$ has no value

(85) Lexical Entries

(86)

a. English: PRES \uparrow
 PAST \langle, \uparrow
 PLUP $\langle, \langle, \uparrow$

a. Russian⁸²: PRES_{Rus} \downarrow
 PRES_{Rus} \uparrow

III. LOGOPHORIC TENSE/MOOD

By comparison with the treatment of Sequence of Tense, the analysis of logophoricity with tense/mood will appear trivial.

In Chapter 1 we made the hypothesis that one of the two subjunctives present in modern German, the Konjunktiv I, was in fact a logophoric tense or mood. As noted before, we do not know for sure whether this form should be analyzed as tense or as mood, and will thus speak of logophoric tense/mood⁹⁰. The natural hypothesis is that logophoric tense/mood is simply the time/world counterpart of logophoric pronouns in Ewe, Gokana or Mapun.

First, recall our analysis of logophoric morphemes in Ewe and in Gokana. The hypothesis was that these were unambiguously specified for the feature \mathfrak{A} , i.e. the diacritic borne by the author coordinate of an embedded context:

- (86) a. Ewe: $y\grave{e}_{\mathfrak{A}}$
 b. Gokana: $LOG_{\mathfrak{A}}$

By parity of reasoning, then, we expect the Konjunktiv I to be specified either for \mathfrak{t} or for \mathfrak{W} , that is, for the diacritic borne by the time or world coordinate of an embedded context. Since we do not know whether \mathfrak{t} or \mathfrak{W} should be used, we henceforth write $\mathfrak{t}/\mathfrak{W}$. Thus the hypothesis is that the Konjunktiv I has the following lexical entry:

- (87) Konj- $I_{\mathfrak{t}/\mathfrak{W}}$

In the person domain, it had been noted that an entry like $y\grave{e}_{\mathfrak{A}}$ had already been used, since the homophony-based analysis of the Amharic 1st person pronoun relied on two entries, one of which was specified for the feature \mathfrak{A} :

- (88) a. $I_{Amh\mathfrak{A}}$
 b. $I_{Amh\mathfrak{a}}$

Exactly the same point can be made about the temporal domain. In the analysis of the Russian present, we relied on two homophonous entries, one of which was specified for the feature \mathfrak{t} :

- (89) $PRES_{Rus\mathfrak{t}}$
 $PRES_{Rus\mathfrak{f}}$

All we do, then, is make use of the same entry (or a world version of the same entry) to account for the behavior of the Konjunktiv I. The major property of the Konjunktiv I follows from this entry: it can only appear in the scope of an attitude operator because only attitude operators introduce embedded contexts whose time/world coordinates bear the feature $\mathfrak{t}/\mathfrak{W}$.

A further question is whether the Konjunktiv I can only, as the theory predicts, be read De Se. The fact that it can only occur in the scope of an attitude operator would lead one to expect precisely this, but given the difficulty of the De Se/De Re tests in the temporal domain, we will not attempt to give direct evidence that the Konjunktiv I is unambiguously De Se.

Finally, and more tentatively, we provide preliminary evidence (i) that the Konjunktiv I is a logophoric tense rather than a logophoric mood, and (ii) that there are no locality constraints on its use [the lack of locality conditions on logophoric pronouns was explicitly mentioned by Clements and Hyman & Comrie].

Consider the following example (C. Krause, p.c.):

(90) Der Peter hat jetzt kein Furunkel und wird deshalb auch morgen nicht
the Peter has now no furuncle and will therefore also tomorrow not
 behaupten, dass er jetzt in diesem Moment eines
claim, that he now in this moment one
 ok hat
has
 ?? habe
have-Konj. I
 ok gehabt habe
had have-Konj. I

'Peter has no furuncle, and he will therefore not claim tomorrow that right now, at this very moment, he has one'.

These contrasts are expected if 'habe' is a logophoric tense, i.e. an element that can only be bound by the time coordinate of an embedded context. Clearly if Peter makes any claim tomorrow, it will not be about (what he believes to be) his present, but about the time at which the actual utterance was made. As a result, the use of a logophoric tense is awkward. There is no reason to expect this if the Konjunktiv I is a logophoric mood: in all these examples Peter makes a claim about the world in which he thinks he lives, and no difference should thus arise between the three conditions.

We this framework in mind, consider the issue of locality (example due to C. Krause, p.c.; again the judgments are subtle, and should be tested further):

(91) Die Maria glaubt nicht, dass der Peter ein Furunkel habe und sie glaubt auch
the Maria believes not that the Peter a furuncle have and she believes also
 nicht, dass er morgen allen Ernstes behaupten wird, dass er heute, in diesem
not that he tomorrow of-all seriousness claim will that he today, in this
 Moment, eines habe⁹¹
moment, one have.

'Maria doesn't believe that Peter has a furuncle, and she also doesn't believe that he will claim tomorrow in all seriousness that today, at this very moment, he has one.'

From the previous example, we know that the most embedded verb 'habe' cannot be evaluated with respect to the context introduced by 'claim' (since the time of the claim is

after the moment at which Peter may or may not have a ...). So it must be bound by the time coordinate of the context introduced by 'believe'. But this shows that binding can in this case occur at a distance, since there is an entire clause between the binder and the bindee. Thus in this case as well Locality seems to play no role at all.

IV. FREE INDIRECT DISCOURSE

There is very little to add on the status of Tense in Free Indirect Discourse, except to point out that it behaves exactly like pronouns. This was already clear in the example we gave in Chapter 3:

(92)

a. Oui, vraiment, il l'aimait, et demain...

Yes, really, he loved her, and tomorrow...

b. $\langle J^j, M^j, 1960^{past}, W^{*n} \rangle \lambda \langle X^j, Y^j, T^{past}, W^n \rangle$ Yes, really, X^j love Y^j ... and tomorrow($\langle X^j, Y^j, T^{past}, W^n \rangle$)...

What is special about Free Indirect Discourse is that the tuple of constants that denotes the context of the speech act may in some cases *fail* to refer to the actual speech act. In such cases the entire sentence that follows the context prefix can be attributed to somebody else than the actual speaker, and the author, hearer and time coordinates may fail to bear the features λ, μ, τ . In the example above John is talking to Mary at some point in our past, and therefore the author and hearer of the initial tuple both bear the feature j . Similarly the time coordinate of the initial tuple bears the feature *Past*, which is now shorthand for \langle, τ . As a result, any variable bound by the time coordinate of the matrix context will be spelled-out with past tense morphology. And this is indeed what happens in Free Indirect Discourse.

It should be observed that the theory developed here makes a somewhat surprising prediction. Given our analysis of Free Indirect Discourse and of Logophoricity, we have no choice but to predict that logophoric forms *cannot* be used in Free Indirect Discourse. Here is why. Logophoric forms (including the Konjunktiv I in German) are lexically specified as being bound by a coordinate of an *embedded* context, i.e. a non-capitalized one. But what is special about Free Indirect Discourse is precisely that, although the speech- or thought'act is attributed to someone else than the actual speaker, the context is a matrix rather than an embedded one. The prediction is a little surprising, since logophoric elements are typically characterized as those that are used to report somebody else's thoughts or speech - precisely what happens in Free Indirect Discourse. But given the way the system is set up, we do not seem to have much room for maneuver.

Let us lay out the prediction in more detail. The logical forms of sentences involving Free Indirect Discourse vs. Logophoric pronouns/tense/mood are the following:

(93) a. Free Indirect Discourse:

$\langle X^*, (Y^*), T^*, W^{*n} \rangle \lambda \langle X, (Y), T, W^n \rangle$... $X^* \mid$ tomorrow($\langle X, (Y), T, W^n \rangle$) ...

b. Logophoric Elements:

[ATT(t, w)] $\lambda \langle x^t, (y^t) \lambda, w^n \rangle$... $x^t \mid$ in-two-days($\langle x^t, (y^t) \lambda, w^n \rangle$) ...

Since the attitude operator we are positing in b. can apparently be covert, it is not *prima facie* clear how we can distinguish Free Indirect Discourse from covertly embedded structures that involve logophoric elements. But in fact the analysis under consideration predicts that several phenomena should be correlated:

(94) a. Free Indirect Discourse:

1. Logophoric forms cannot be used, non-logophoric ones can.
2. Matrix indexicals ('tomorrow') can appear with a shifted reading (since the structure is not embedded)
3. There cannot be a De Dicto / De Re distinction (because there is no attitude operator).

b. Covertly Embedded Structures with Logophoric Elements:

1. Logophoric forms can be used.
2. Matrix indexicals ('tomorrow') cannot appear with a shifted reading (since the structure is embedded)
3. There can be a De Dicto / De Re distinction (because there is a covert attitude operator).

Since Free Indirect Discourse does not involve any attitude operator, matrix indexical adverbs like 'tomorrow' should be allowed to have a shifted reading (since the context of Free Indirect Discourse is capitalized, just as any other matrix context; the only difference lies in the diacritics which the coordinates of the context do or do not bear, but this is irrelevant - but these are irrelevant for the well-formedness of 'tomorrow'). By contrast, 'tomorrow' should not be allowed to appear in a covertly embedded structure with logophoric elements, since the context is embedded (non-capitalized). Furthermore, since covertly embedded structure involve an attitude operator, they should in principle yield De Dicto/De Re distinctions; Free Indirect Discourse should not, since it does not any attitude operator at all.

So what are the facts? We have too little evidence at this point to draw any definite conclusion. The facts relevant to Property 3 are very fuzz. Preliminary results on Property 2 suggest that the prediction might be borne out; but they be handled with extreme caution, given that we have not done any serious fieldwork on this:

- (94) a. Peter war sehr deprimiert. Ja, heute ging alles schief.
Peter was very depressed. Yes, today went everything wrong
 'Peter was very depressed. Yes, today everything was going wrong'
- b. *Peter war sehr deprimiert. Ja, heute gehe alles schief.
Peter was very depressed. Yes, today go-Konj.I everything wrong . [I. Heim, p.c.]⁹²

The logic of these examples is to correlate the use of a matrix indexical ('heute' = 'today') with the use of the Konjunktiv I vs. Indicative. The cooccurrence of 'heute' and

of a past tense situation (introduced by the first sentence) should force a Free Indirect Discourse reading. This, in turn, should make the indicative acceptable, and should rule out the use of the Konjunktiv I - apparently a correct result⁹³.

APPENDIX. FUTURE TENSE AND MOOD

In this Appendix we consider some problems raised for the theory by the Future, and some extensions of the analysis to Mood. We first consider feature transmission under 'will', then translate into our framework Abusch's account of Double Access Readings, and finally show that Double Access effects exist in the world domain as well.

I. Feature transmission under 'will'

The first problem raised by the Future is that 'will' (and future morphemes in other languages) can shift the point of evaluation of temporal elements that are in its scope:

- (1) a. Mary will say tomorrow that John IS crying (at the time of her speech act)
 b. Mary will meet a person who IS crying (at the time of the meeting)
- (1') a. Marie dira demain que Jean pleure (at the time of Marie's speech act)
Marie will-say tomorrow that Jean is-crying
 b. Marie rencontrera une personne qui pleure (at the time of the meeting)
Marie will-meet a person who is-crying
- (2) a. Mary will say in a week that John WAS crying two days earlier.
 b. In a week Mary will meet a person who WAS crying two days earlier.
- (2') a. Marie dira dans une semaine que Jean pleurait deux jours avant.
Marie will-say in a week that Jean was-crying two days before
 b. Dans une semaine Marie rencontrera une personne qui pleurait deux
In a week Marie will-meet a person who was-crying two
 jours avant.
days before

Although in simple sentences a present tense is bound by the time coordinate of the matrix context, this is clearly not the case here. Rather, the present in (1) refers to the time of Mary's future utterance in (1a), and to the time of the meeting in (1b). Similarly the time of John's crying is supposed to be before Mary's future utterance in (2a), and before the time of the meeting in (2b). And given the content of the claims, John's crying is supposed to take place *after* the time of the actual utterance.

Does this pose a threat to the theory developed here? Not really. It is true that the English present always spells-out a variable with a \uparrow feature, and that in many cases the feature is inherited through binding by the time coordinate of the matrix context. But this is not always the case, as was already discussed before. First, in the temporal version of Heim's examples, a variable with a \uparrow feature can be bound by [only now] rather than by the time coordinate of the matrix context:

- (3) a. [Only now] is the Concord in Paris.
 b. $\langle X^{\uparrow}, Y^{\uparrow}, T^{\uparrow}, W^{\uparrow} \rangle \lambda \langle X^{\uparrow}, Y^{\uparrow}, T^{\uparrow}, W^{\uparrow} \rangle$
 [Only [now($\langle X^{\uparrow}, Y^{\uparrow}, T^{\uparrow}, W^{\uparrow} \rangle$)] \uparrow] λt^{\uparrow} [the Concord be in Paris at t^{\uparrow}]

Similarly, we postulated that in attitude environments a variable bound by the time coordinate of an *embedded* context could inherit a \bar{T} feature from the matrix present tense, as in the following example (discussed above):

- (4) a. John hopes that it IS raining
 b. $\langle \dots T^{\bar{T}} \dots \rangle \lambda \langle \dots T^{\bar{T}} \dots \rangle$ John hopes at $T^{\bar{T}}$ $\lambda \langle \dots t^{\bar{T}} \dots \rangle$ it rains at $t^{\bar{T}}$

The principle of agreement that was required was encoded in the following formation rule, already used in the person domain:

- (5) If ϕ is a well-formed formula and if ATT is an attitude operator,
 $ATT(x^{\bar{t}}, (y^{\bar{t}}), t^{\bar{t}}, w^{\bar{t}}) \lambda \langle x^{\bar{t}}, (y^{\bar{t}}), t^{\bar{t}}, w^{\bar{t}} \rangle \phi$ is a well-formed formula.
 [where $\bar{t}, \bar{t}, \bar{t}, \bar{t}$ stand for the set of all features that appear on $x, y, t,$ and w respectively]

The obvious strategy, then, is to use the same type of formation rule for the future. Thus 'will' is treated as a present tense operator, which can transmit a \bar{T} feature to an element which is in its scope. Similarly 'would' is analyzed as a past tense operator, with an analogous mechanism of feature transmission. The proposal might look less controversial than it really is. While there is some evidence in English that 'will' is morphologically present, this is not the case in other languages (e.g. French), which nonetheless display the same patterns of agreement under future operator. Be that as it may, the proposal is that morphologically the future is more similar to an attitude operator than to a true tense like the present or the past. We leave it for future research to determine why this should be.

For simplicity, we follow Abusch 1997 and treat 'will' as a raising verb. We can then define the following lexical entry:

- (6) If ϕ is a well-formed formula,
 $WILL(t^{\bar{t}}) \lambda t^{\bar{t}} \phi$ is a well-formed formula.
 [where \bar{t} stands for the set of all features that appear on t and $t^{\bar{t}}$]

Since the problem is morphological, the interpretation of 'will' can be entirely standard: $WILL(t) \lambda t^{\bar{t}} \phi$ is true just in case there is a point after $[[t]]$ at which ϕ is true:

- (3) If s is an assignment,
 $[[WILL(t) \lambda t^{\bar{t}} \phi]]_s$ is true iff
 for some assignment s' identical to s except for the value assigned to $t^{\bar{t}}$,
 $[[t^{\bar{t}}]]_{s'} > [[t]]_s$ and $[[\phi]]_{s'} = \text{true}$.

[The definition would have to be refined, for instance to treat cases of temporal anaphora in the future. For our purposes this simple formalization will be sufficient].

First, let us consider the effects of the formation rule in cases that do not involve an attitude operator:

(4) a. Mary will meet a person who IS crying (at the time of the meeting)

b. $\langle \dots T^{\uparrow}, W^{\uparrow} \rangle \lambda \langle \dots T^{\uparrow}, W^{\uparrow} \rangle \text{WILL}(T^{\uparrow}) \lambda t^{\uparrow}$ [Mary meets at t^{\uparrow} a person who cries at t^{\uparrow} in W^{\uparrow}]

Obviously b. leaves a lot to be explained, in particular why 'meet', which is represented with a time variables that bears the feature \uparrow , is spelled-out as a bare root rather than as a present. On the other hand we do get the important fact that 'cries' should appear with present tense morphology, even though it is semantically shifted.

It is worth noting that given the definition of the past tense as an obviative present, a past tense can automatically be shifted as soon as a present can be (this is because a variable with past tense features is anchored to a variable with present tense features; if the present can be shifted, so can the past). This appears to be correct:

(5) a. Mary will meet a person who WAS crying

b. $\langle .T^{\uparrow} \rangle \lambda \langle .T^{\uparrow} \rangle \text{WILL}(T^{\uparrow}) \lambda t^{\uparrow}$ [Mary meets at t^{\uparrow} a person who cries at t^{\uparrow} [$t^{\uparrow} < t^{\uparrow}$]...]

In a notation without diacritics, this becomes:

(6) a. Mary will meet a person who WAS crying

b. $\langle .T^* \rangle \lambda \langle \dots T \dots \rangle \text{WILL}(T) \lambda t_1$ [Mary meets at t_1 a person who cries at t_2 [$t_2 < t_1$]...]

Cases that involve an attitude verb in the future are just a more complicated version of the same thing. Here is an example:

(7) a. Mary will say tomorrow that John IS crying (at the time of her speech act)

b. $\langle .T^{\uparrow} \rangle \lambda \langle .T^{\uparrow} \rangle \text{WILL}(T^{\uparrow}) \lambda t^{\uparrow}$ [Mary says at t^{\uparrow} that $\lambda \langle .t^{\uparrow} \rangle$ John be crying at t^{\uparrow} ...]

2. If the future is so similar to attitude operators, should the two cases be unified and treated as a single natural class? This is the suggestion made (somewhat tentatively) in Abusch 1997, where 'will' is called an 'intensional' operator, one which can shift the evaluation time of a tense without affecting its morphology⁹⁴. Part of her motivation is that 'will' patterns not just with attitude operators, but also with modals, which trigger the same patterns of temporal agreement:

(8) Mary might meet tomorrow a person who IS crying (at the time of the meeting)

It is not entirely clear what natural notion of an 'intensional operator' could at the same time include 'will', modals and attitude operators, and still exclude past tenses⁹⁵. But certainly we can treat the syntax of 'will' as that of an operator, with the result that, in our framework, a future tense does not appear as a diacritic on time variables, and thus is not a 'tense' in the technical sense. This is empirically desirable, but at the moment there is no deeper motivation for this stipulation.

Still, despite the similarities between 'will', 'might' and attitude operators, it is not possible to reduce them to a single class. If we were to look only at Sequence phenomena, the reduction might appear to work. But for some of the other facts we have looked at, a further distinction is needed between attitude operators and other intensional elements:

- 'in two days' can be shifted under an attitude operator, but not under 'will' (although the facts are not particularly sharp):

(9) a. John has repeatedly told me that someone would give his money back in two days [= exactly two days after the conversation].

b. #John will meet in a week someone who will give him his money back in two days.

(9') a. Jean m'a souvent répété qu'il me rendrait mon argent dans deux jours.

b. #Jean rencontrera dans une semaine une personne qui lui rendra son argent dans deux jours.

This split is expected in the present framework. 'in two days' is defined as a function symbol that takes a context variable as argument. But 'will' does not introduce a context variable (i.e. a 3- or 4-tuple of coordinates) at all, and therefore there is no reason to expect that 'in two days' could be shifted under a future operator.

With respect to 'in two days', then, attitude operators and other intensional operators part company.

- The Konjunktiv I in German can be used to make the same point: it can appear in the scope of an attitude operator, but not of 'will', as shown by the following:

(10) a. Der Peter hat mir erzählt, dass die Maria krank sei / ist
the Peter has to-me told, that the Maria sick be / is

b. # Morgen wird der Peter eine Frau treffen, die krank *sei / ist
tomorrow will the Peter a woman meet, who sick be / is

Again, the split is expected in the present framework. The Konjunktiv I is defined as a logophoric tense (or maybe mood), and is thus lexically specified as having a feature \bar{t} which it can only inherit from an embedded context. But 'will' quantifies over times, not over contexts, and therefore it does not introduce the relevant feature in the representations. As a result, the Konjunktiv I cannot be shifted under 'will'.

The conclusion, then, is that attitude operators are special, and cannot be entirely assimilated to other intensional operators. This is consistent with the theory advocated here, in which only attitude operators are analyzed as quantifiers over contexts.

II. Upper Limit Constraint and Double-Access Readings

1. The Upper Limit Constraint

The future also raises a second problem, which is of a purely semantic nature. It has been observed (e.g. in Ogihara 1996 and Abusch 1997) that 'forward shifted' readings are systematically deviant unless a form of 'will' is used in the embedded clause. In other words, somebody's beliefs about a point that lies in (what he believes to be) his future cannot be reported unless some form of 'will' appears in the report. Consider for instance the following:

- (11) **Situation:** John believed in 1980: 'Mary will die in 1985'
 a. #John believed in 1980 that Mary dieD in 1985
 b. John believed in 1980 that Mary WOULD die in 1985

The situation is one in which John's belief is that Mary will die at some point in his future. The surprising fact is that although that point (1985) is in our (the speaker's) past, the report in (a) is markedly deviant. As soon as 'will' (here in the past tense) is used, as in (b), the sentence becomes acceptable.

The same facts can be replicated when one attempts to report in the present tense a belief about a point that lies in an agent's future [more precisely, in what the agent believes to be his future]:

- (12) **Situation:** John believed in 1997: 'Mary will be pregnant in August 1999'
 a. [Uttered in August 1999]
 #John believed in 1997 that Mary is (now) pregnant
 b. [Uttered in August 1999]
 John believed in 1997 that Mary would (now) be pregnant

(We will see shortly that an example like a. becomes acceptable in case John's belief was about an interval that includes both the time of his belief, and the time of the report).

It should be noted that the problem appears to be specifically tied to reference to an agent's *future*. As noted in Higginbotham 1998, there does not appear to be any clear constraint against reporting in the present a belief about an agent's past, as shown by the following examples

- (13) a. Gianni will say that Maria is dancing well (right now) [Higginbotham's (29)]
 b. Tomorrow you will recognize that you are (now) being difficult
 c. Tomorrow everyone will know what you are doing right now.

In order to capture these facts, Abusch 1997 (discussed in Heim 1994) states a constraint on tense denotations, which she calls the 'Upper Limit Constraint'. Since for her the future counts as a modal rather than as a tense, she can state the constraint as follows:

'... the now of an epistemic alternative is an upper limit for the denotation of tenses. Given that the now of a belief is equated with the local evaluation time of the complement of 'believe', we can restate this by saying that the local evaluation time is an upper limit for the denotation of tenses.' (Abusch 1997 p. 25).

Within our framework, we can define Abusch's Upper Limit Constraint as follows (see Heim 1994 for a technical discussion):

- (14) If t is in the scope of an attitude operator, and if s is an assignment, $[[t]]_s$ cannot be such that $[[t]]_s > [[\tau]]_s$, where τ is the time variable introduced by the closest operator (=attitude operator or 'will' – or a modal).

2. Double-Access Readings

Abusch's Upper Limit Constraint has the advantage of deriving an interesting fact: when a variable with present tense features appears under an attitude verb in the past tense, the sentence is acceptable *only if* the thought/utterance which is reported was about an interval that includes *both* the time of thought and the time of the actual utterance (see Ogihara 1996 and Abusch 1997 for a discussion):

- (15) a. John said three months ago that Mary was pregnant
 b. John said three months ago that Mary is pregnant
 c. John said twelve months ago that Mary was pregnant
 d. #John said twelve months ago that Mary is pregnant

While both a. and b. are grammatical, there is a subtle difference between the two. In a. John's claim is simply that Mary was pregnant at the time of his utterance. But in b., his claim has to imply in addition that Mary would still be pregnant three months later, i.e. now. This explains why d. is odd: since a pregnancy normally lasts 9 rather than 12 months, it is hard to think of a scenario that would make d. true.

The intuitions can be made sharper by looking at examples that involve factive verbs:

- (16) a. John knew three months ago that Mary was pregnant
 b. John knew three months ago that Mary is pregnant

While the first sentence only presupposes that Mary was pregnant three months ago, the second one presupposes both that Mary was and still is pregnant.

Why should there be Double Access effects? Here again we essentially follow Abusch's analysis, recast in our framework. The Sequence-of-Tense cases are unproblematic. The non-SOT examples don't leave us much room for maneuver. In English, a present tense can only spell-out a variable with a \uparrow feature. And since the matrix verb is in the past tense, the only way the variable could bear the feature is by inheriting it through binding by the time coordinate of the matrix context:

- (17) $\langle \dots T^{\uparrow} \dots \rangle \lambda \langle \dots T^{\uparrow} \dots \rangle$ John knows at $t^{\langle, \uparrow} [t^{\langle, \uparrow} < T^{\uparrow}] \dots$
 $\lambda \langle \dots t^{\langle, \uparrow} \dots \rangle$ Mary be pregnant at $T^{\uparrow} \dots$

or without diacritics:

- (18) $\langle \dots T^* \dots \rangle \lambda \langle \dots T \dots \rangle$ John knows at $t_1 [t_1 < T] \dots$
 $\lambda \langle \dots t_2 \dots \rangle$ Mary be pregnant at $T \dots$

Since the embedded variable must be bound by the time coordinate of the matrix context, it is unsurprising that Mary's pregnancy should hold at the time of utterance. But why does it also have to hold at the time of John's thought act?

In a nutshell, Abusch's idea is that this is a consequence of the Upper Limit Constraint. Unless the interval at which Mary is pregnant according to John also includes John's 'now' (=the point at which he believes his thought act to be taking

place), the sentence is bound to violate the Constraint. This is because John's thought would be about an interval that would lie entirely in his future, even though no form of 'will' is used in the report.

In order to make this precise, we have to enrich the system so as to allow for reference to intervals rather than just moments. In general, a present tense does not have to mean that a particular event holds at the *moment* of utterance. Rather, it often means that it holds at a (salient) interval that *includes* the speech time. Thus in the following examples it is natural to assume that the feature \bar{T} on the interval variable $\underline{t}^{\bar{T}}$ (which is underlined to indicate that it ranges over intervals) contributes a presupposition that $\underline{t}^{\bar{T}}$ overlaps the time of utterance. We further assume that in this case the interval $\underline{t}^{\bar{T}}$ functions as a domain restriction [for notational convenience we use 'o' for the overlap relation, even though the cases we study only involve set membership of an element to an interval]:

- (19) a. Every Monday John sees a movie (but this didn't use to be the case)
 b. $\langle \dots T^{\bar{T}} \dots \rangle \lambda \langle \dots T^{\bar{T}} \dots \rangle$ Every $(\lambda t$ t is a Monday & $t \in \underline{t}^{\bar{T}}[\underline{t}^{\bar{T}}OT^{\bar{T}}])$ $(\lambda t$ John sees a movie at t)

Similarly, a past tense typically means that an event holds at an interval which is entirely before the utterance time:

- (20) a. Every Monday John saw (used to see) a movie (but now he doesn't any more)
 b. $\langle \dots T^{\bar{T}} \dots \rangle \lambda \langle \dots T^{\bar{T}} \dots \rangle$ Every $(\lambda t$ t is a Monday & $t \in \underline{t}^{\bar{T}}[t < T^{\bar{T}}])$ $(\lambda t$ John sees a movie at t)

This minor modification will be enough to give the key to the Double-Access phenomenon. Abusch's idea was that Double-Access readings are derived from two constraints for which there is independent evidence:

(i) Since 'will' does not appear in the reporting clause, the original speech- or thought-act must have been about an interval that was not *after* the time of thought (rather, what the agent believed to be the time of thought).

(ii) Since the reporting clause contains a present tense embedded under a past tense, the interval must also include the time of the actual speech act.

(i) and (ii) can be reconciled just in case the embedded tense refers to an interval which includes *both* the agent's 'now' and the speaker's 'now'. We show this more formally in the following system:

(21) [Sketch]

- a. Non-logical symbols: add O (< is reinterpreted)
 b. Syntax: add the rule

A variable of the form $\underline{t}^{\bar{T}}$ (with $\underline{t}^{\bar{T}}$ underlined) is ill-formed unless immediately followed by $[\underline{t}^{\bar{T}} o \tau]$, where τ is a variable with diacritic \bar{T}

c. Interpretation

- If s is an assignment, $[[t [\underline{t}^{\bar{T}} o t']]]_s = [[t]]_s$ if $[[t']]_s$ belongs to $[[t]]_s$

Otherwise $[[[t [t o t']]]_s]$ has no value

• If s is an assignment, $[[[t [t < t']]]_s] = [[t]]_s$ if $[[t]]_s$ is before $[[t']]]_s$ [i.e. if all elements of $[[t]]_s$ are before $[[t']]]_s$)

The case in which the embedded tense agrees in features with the matrix tense is unproblematic: the embedded time variable is bound by the time coordinate of the embedded context, and the Upper Limit Constraint is automatically satisfied. The only additional presupposition comes from the factivity of 'know', which entails that the embedded proposition (rather, character) should indeed hold at the point of thought:

- (22) a. John knew that Mary WAS pregnant
 b. $\langle \dots T^{\uparrow} \dots \rangle \lambda \langle \dots T^{\uparrow} \dots \rangle$ John knows at $t^{\uparrow} [t^{\uparrow} < T^{\uparrow}]$ /PAST_T/ ...
 $\lambda \langle \dots t'^{\uparrow} \dots \rangle$ Mary be pregnant at $t'^{\uparrow} [t'^{\uparrow} o t'^{\uparrow}]$ /PAST_T/ ...

or without diacritics:

- b'. $\langle \dots T^* \dots \rangle \lambda \langle \dots T \dots \rangle$ John knows at $t [t < T]$...
 $\lambda \langle \dots t' \dots \rangle$ Mary be pregnant at $t' [t' o t']$...

Factive presupposition: The embedded clause holds at the point of thought, i.e. $[\lambda \langle x^{\uparrow}, t'^{\uparrow}, w^{\uparrow} \rangle \text{Mary be pregnant at } t'^{\uparrow} [t'^{\uparrow} o t'^{\uparrow}]]$ in $w^{\uparrow} (\langle \text{John}, t^{\uparrow}, W^{\uparrow} \rangle) = \text{true}$, i.e. Mary is pregnant at t^{\uparrow} in W^{\uparrow}

Things are more interesting in examples with a Double-Access reading. There the time variable of the embedded clause must denote an interval that includes both the time of thought and the speech time:

- (23) a. John knew that Mary IS pregnant
 b. $\langle \dots T^{\uparrow} \dots \rangle \lambda \langle \dots T^{\uparrow} \dots \rangle$ John knows at $t^{\uparrow} [t^{\uparrow} < T^{\uparrow}]$ /PAST_T/ ...
 $\lambda \langle \dots t'^{\uparrow} \dots \rangle$ Mary be pregnant at $t'^{\uparrow} [t'^{\uparrow} o T^{\uparrow}]$ /PRES_T/ ...

or without diacritics:

- b'. $\langle \dots T^* \dots \rangle \lambda \langle \dots T^{\uparrow} \dots \rangle$ John knows at $t [t < T^{\uparrow}]$...
 $\lambda \langle \dots t' \dots \rangle$ Mary be pregnant at $t' [t' o T]$...

Here the embedded time variable is forced to denote an interval that satisfies two conditions:

- ⇒ Because of the present tense morphology, it must include the time of the actual speech act.
- ⇒ Because of the Upper Limit Constraint, it must include (what the agent believes to be) the time of thought.
- ⇒ Finally, because of the factive presupposition, the embedded clause must hold at the point of John's thought.

Formally:

- (24) Presuppositions on \underline{t}^{\uparrow} : (i) $\underline{t}^{\uparrow} \circ T^{\uparrow}$ [as stated in the logical form]
(ii) $\underline{t}^{\uparrow} \circ t^{\leftarrow \uparrow}$ [Upper Limit Constraint]

Factive presupposition: The embedded clause holds at the point of John's thought, i.e. $[\lambda \langle x^{\uparrow}, t^{\leftarrow \uparrow}, w^{\#} \rangle \text{ Mary be pregnant at } \underline{t}^{\uparrow} [\underline{t}^{\uparrow} \circ T^{\uparrow}]]$ in $w^{\#}$ ($\langle \text{John}, t^{\leftarrow \uparrow}, W^{\#} \rangle$) = true, i.e. Mary is pregnant at \underline{t}^{\uparrow} in $W^{\#}$

But from the presuppositions on \underline{t}^{\uparrow} :

- (i) $\underline{t}^{\uparrow} \circ T^{\uparrow}$
(ii) $\underline{t}^{\uparrow} \circ t^{\leftarrow \uparrow}$

Hence Mary is pregnant at T^{\uparrow} as well as $t^{\leftarrow \uparrow}$

We predict, of course, that Double-Access effects should *not* hold (that is, should not be obligatory) in languages that either display no SOT effects, or else have optional SOT. This is indeed borne out, as shown by the following example from Modern Greek (where Sequence of Tense is optional for Present-in-the-Past. Thus in Modern Greek the past tense in a. has, among others, a simultaneous, De Se reading; but the present tense can apparently be used with the same meaning in b.):

- (25) a. Prin apo 10 chronia o Kostas iksero oti i Maria itan engios
Before 10 years the Kostas knew that the Maria was pregnant
b. Prin apo 10 chronia o Kostas iksero oti i Maria ine engios
Before 10 years the Kostas knew that the Maria is pregnant

This can be explained if Modern Greek 'ine' has the option of being specified for the feature \downarrow , which allows it to be bound by the time coordinate of the embedded context:

- (26) Lexical entry for Modern Greek 'is': /ine_↓/ or /ine_↑/

The Greek sentence can now receive the following analysis, in which the only constraint on the interval denoted by the embedded variable is that it should overlap with the value of the time coordinate of the embedded context:

- (27) $\langle \dots T^{\uparrow} \dots \rangle \lambda \langle \dots T^{\uparrow} \dots \rangle$ John knows at $t^{\leftarrow \uparrow} [t^{\leftarrow \uparrow} < T^{\uparrow}]$ /PAST_↓/ ...
 $\lambda \langle \dots t^{\leftarrow \uparrow} \dots \rangle$ Mary be pregnant at $\underline{t}^{\uparrow} [\underline{t}^{\uparrow} \circ t^{\leftarrow \uparrow}]$ /ine_↓/ ...

or without diacritics:

- (28) $\langle \dots T^{\uparrow} \dots \rangle \lambda \langle \dots T \dots \rangle$ John knows at $t [t < T]$...
 $\lambda \langle \dots t \dots \rangle$ Mary be pregnant at $\underline{t} [\underline{t} \circ t]$...

[Apparently there is no blocking effect between /ian/ and /ine/, for reasons I do not understand]

III. Speculations on Sequence of Mood

So far we have shown that Sequence phenomena exist in the person and in the tense domains. In the latter case we saw that Abusch's Upper Limit Constraint interacted with Sequence Phenomena to yield Double Access Readings. We now attempt to extend some of these results to the world domain. Since contexts as we have formalized them have a world coordinate which is treated exactly like the author, hearer and time coordinate, we expect that there should be Sequence Phenomena in the world domain as well – what we will call 'Sequence of Mood' effects. Of course if these phenomena didn't exist we could change the theory so as to treat the world variable differently from other context coordinates - we could decide, for that matter, that contexts don't have a world coordinate at all, and that evaluation at a world is achieved in a different way. But that would complicate the theory. And fortunately it won't be necessary. For Sequence phenomena do exist in the world domain as well.

3.1. Sequence of Mood Effects: the Generalization

We wish to suggest that there are Sequence phenomena, and in fact Double Access Readings, in the world domain. The world counterpart of the present/past contrast is the distinction between indicative and subjunctive morphology in conditionals – or so we will speculate. The purported generalization has two components:

(i) As we just saw, when an English present tense is embedded under an attitude verb in the past tense, a Double-Access Reading ensues. Things are particularly clear when the attitude verb is factive, since in that case the Double-Access Reading presupposes that the embedded clause holds both at the time of thought and at the time of the actual speech act. The surprising observation is that similar facts appear to hold with mood. In the antecedent of a conditional, when an indicative verb is embedded under 'know' in the subjunctive, a reading is obtained in which the embedded clause must hold both at the actual world and at the counterfactual world picked out by the if-clause. This appears to be the world counterpart of a Double-Access Reading⁹⁶.

(ii) In Modern Greek, Sequence of Tense is optional for present-in-the-past; as a result, there do not seem to be any Double Access effects. Remarkably, similar facts appear to hold in the world domain. Whereas in English an indicative verb embedded under subjunctive 'know' yields a presupposition that the embedded clause holds at the actual world, there does not appear to be a similar constraint in Modern Greek.

Let us now consider the facts, which we try to describe in a theory-neutral fashion.

(i) English

(29) a. If Mary <was [were] in a situation where she> knew that Clinton WAS [were] dead... [she would be devastated.]

=> does NOT presuppose that Clinton is actually dead [but does presuppose that Clinton is dead in the counterfactual world picked out by the if-clause]

b. If Mary <was [were] in a situation where she> knew that Clinton IS dead... [she would be devastated.]

=> presupposes that Clinton is actually dead [and also presupposes that Clinton is dead in the counterfactual world picked out by the if-clause]

The contrast between the two cases is subtle, but interesting. b. is awkward given our knowledge of the world; the sentence seems inappropriate, because it appears to presuppose that Clinton is actually dead. There is no such presupposition in a., which is thus perfectly appropriate. To put things more sharply, a. only presupposes that Clinton is dead in the counterfactual world picked out by the if-clause; but b. presupposes in addition that Clinton is dead in the actual world. Now recall the following cases from the temporal domain:

(30) a. John knew three months ago that Mary was pregnant

⇒ does NOT presuppose that Mary is pregnant right now [but does presuppose that Mary was pregnant at the time of John's thought act]

⇒

b. John knew three months ago that Mary is pregnant

=> presupposes that Mary is pregnant right now [and also presupposes that Mary was pregnant at the time of John's thought act]

(29b) thus appears to be parallel to the Double Access reading illustrated in (30b): when mood agreement fails to obtain between the embedded and the matrix clause, the embedded clause is presupposed to hold both at the actual and at the counterfactual worlds that are talked about (in a sense to be made precise).

The analogy can be made more complete by considering temporal cases involving when-clauses - nothing essential changes, except that for plausibility the matrix verb has to be replaced with another factive verb⁹⁷:

(31) a. [Until last month, even] when John admitted that Mary was pregnant ... [in general his interlocutors still didn't believe it]

=> does NOT presuppose that Mary is pregnant right now [but does presuppose that Mary was pregnant at the time of John's thought act]

a'. [Jusqu'au mois dernier, même] quand Jean reconnaissait que Marie était enceinte... [en général ses interlocuteurs ne le croyaient pas]

=> same as a.

b. [Until last month, even] when John admitted that Mary is pregnant ... [in general his interlocutors still didn't believe it]

=> presupposes that Mary is pregnant right now [and also presupposes that Mary was pregnant at the time of John's thought act]

b'. [Jusqu'au mois dernier, même] quand Jean reconnaissait que Marie est enceinte, ses interlocuteurs ne le croyaient pas.

⇒ same as b.

(ii) Modern Greek

Double-Access effects appear to fail in Modern Greek not just in the time domain, but also in the world domain. As it turns out, Modern Greek has the option of retaining in reported speech the mood of a direct discourse, even when the attitude verb bears counterfactual features:

(32) <a. An i Maria itan engios ke o Kostas iksero oti i Maria itan engios ...
if the M. was pregnant and the K. knew that the M. was pregnant...
=> no presupposition that Maria is actually pregnant>

b. An i Maria itan engios ke o Kostas iksero oti i Maria ine engios ...
if the M. was pregnant and the K. knew that the M. is pregnant....
=> also no presupposition that Maria is actually pregnant

[A further observation is that in Modern Greek, as some dialects of English and many other languages, the same morphemes are used for the expression of present tense/indicative mood and for past tense/subjunctive mood. What we see, then, is that in Modern Greek the two uses of the same form behave in the same way with respect to Sequence phenomena: Double-Access effects fail to hold both in the temporal and in the modal domain. See Iatridou 1998 for an insightful discussion of syncretisms between tense and mood].

3.2. Towards an analysis?

A full account of these facts goes beyond this work. What could an analysis look like? Here is a partial suggestion:

- When Sequence of Mood is applied in English, the embedded world variable denotes a set of world that must overlap the value of the world coordinate of the embedded context – and this is the only constraint there is. Therefore the factive presupposition only entails that the embedded clause holds at the counterfactual world picked out by the if-clause.

- When Sequence of Mood is not applied, the embedded world variable denotes a set of worlds that must, among others, overlap with the value of the world coordinate of the *matrix* context. As a consequence, the factive presupposition entails that the embedded clause should hold throughout that set of worlds, and thus in particular in the actual world.

Of course this only derives half of the Double Access effect. We would also have to explain why the embedded clause must, in addition, hold at the counterfactual world(s) picked out by the if-clause. Presumably a world version of Abusch's Upper Limit Constraint is called for, but we leave this for future research.

The hope, then, is that the following type of logical forms could be posited. Morphologically, a subjunctive is analyzed as a bundle of features \langle, \mathbb{W} , while an indicative corresponds to the single feature \mathbb{W} . The obvious suggestion is that the difference between English and Modern Greek is that in the latter case the indicative can be specified either for \mathbb{W} or for its embedded counterpart \mathbb{w} , while an English indicative can only be specified for \mathbb{W} . The result would look like this:

English

- (33) a. <If> Mary knew that Clinton WAS dead....
b. <... W*^W> λ<... W^W> ... Mary knows in w^W...
λ<... w'^W> Clinton be dead in w''^W [w''^W o w'^W]

- (34) a. <If> Mary knew that Clinton IS dead....
b. <... W*^W> λ<... W^W> Mary knows in w^W...
λ<... w'^W> Clinton be dead in w''^W [w''^W o W^W] ...

Modern Greek

- (35) a. lit. <If> Mary knew that Clinton WAS dead....
b. = (36b)
- (36) a. lit. <If> Mary knew that Clinton IS dead....
= (36b) as well, but 'ine' can spell-out w [while English 'is' can only spell-out W]

REFERENCES

- Abusch, Dorit (1988) 'Sequence of Tense, Intensionality and Scope', *Proceedings of WCCFL* 7.
- Abusch, Dorit (1997) 'Sequence of Tense and Temporal *De Re*', *Linguistics & Philosophy* 20: 1-50
- Aissen, Judith (1997) 'On the Syntax of Obviation', *Language* 73.4
- Anderson, S. R. & E. L. Keenan (1985) 'Deixis', in Shopen, M. (ed.) *Language Typology and Syntactic Description*, vol. 3: 'Grammatical Categories in the Lexicon', Cambridge University Press.
- Anscombe, G. E. M (1975) 'The First Person', reprinted in Cassam, Quassim, ed. *Self-Knowledge*.
- Banfield, Ann (1982) *Unspeakable Sentences (Narration and Representation in the Language of Fiction)*, Routledge & Kegan Paul.
- Barentsen, Adrian (1996) 'Shifting points of orientation in Modern Russian: Tense selection in 'reported perception'', in Janssen & van der Wurff, ed. *Reported Speech*
- Bäuerle, Rainer (1989) 'Ereignisse und Repräsentationen', LILOG-REPORT 43, IBM Deutschland.
- Benthem, J. van (1978) 'Tense logic and standard logic', *Logique et Analyse* 80, 47-83.
- Bevington, Barbara (1998) *Indexical Expressions: Syntax and Context*, Dissertation, CUNY.
- Bloomfield, Leonard (1962) *The Menomini Language*.
- Cassam, Quassim [ed.] (1994) *Self-Knowledge*, Oxford University Press.
- Castañeda, Hector-Neri (1966) 'He: A Study in the Logic of Self-Consciousness', *Ratio* 7.
- Castañeda, Hector-Neri (1967) 'Indicators and Quasi-Indicators', *American Philosophical Quarterly*, Volume 4, Number 2.
- Castañeda, Hector-Neri (1968) 'On the Logic of Attributions of Self-Knowledge to Others', *The Journal of Philosophy*, Volume 65, Number 15.
- Castañeda, Hector-Neri (1969) 'On the Phenomeno-Logic of the I', *Proceedings of the 14th International Congress of Philosophy*, reprinted in Cassam (ed.) 1994.
- Chierchia, Gennaro (1987) 'Anaphora and Attitudes *De Se*', in Bartsch, van Benthem & van Emde Boas (eds), *Language in Context*, Doris.
- Clements, George N. (1979) 'The logophoric pronoun in Ewe: Its role in discourse', *Journal of West African Languages* 10: 141-77
- Cooper, Robin (1983) *Quantification and Syntactic Theory*, Reidel.
- Cresswell, Maxwell (1990) *Entities and Indices*, Kluwer
- Cresswell, Maxwell J. & Arnim von Stechow (1982) 'De Re Belief Generalized', *Linguistics and Philosophy* 5: 503-535
- Dahlstrom, Amy (1991) *Plains Cree Morphosyntax*, Garland.
- Doron, Edit (1991) 'Point of View as a Factor of Content', SALT I.
- Dubinsky, Stanley & Robert Hamilton (1998) 'Epithets as Antilogophoric Pronouns', *Linguistic Inquiry*, Fall 1998, 685-693
- Duden (1998) *Grammatik der deutschen Gegenwartssprache*. 6., neu bearbeitete Auflage.
- Enç, Mürvet (1987) 'Anchoring Conditions for Tense', *Linguistic Inquiry*, 18.4
- Fintel, Kai von (1997) 'The Presupposition of Subjunctive Conditionals', MIT Working Papers in Linguistics 25, eds. Orin Percus and Uli Sauerland.
- Fintel, Kai von (1998) 'Counterfactuals in a Dynamic Context', ms., MIT.
- Frantz, Donald G. (1966) 'Person Indexing in Blackfoot', *International Journal of American Linguistics*, Volume 32, 50-59.

- Frajzyngier, Zygmunt (1985) 'Logophoric Systems in Chadic', *Journal of African Languages and Linguistics* 7: 23-37
- Goodwin, William Watson (1879) *A Greek Grammar*, St Martin's Press
- Haas-Spohn, Ulrike (1995) *Versteckte Indexicalität und subjektive Bedeutung*, *Studia Grammatica* 38, Akademie Verlag.
- Halle, Morris (1997) 'Distributed Morphology: Impoverishment and Fission', *MIT Working Papers in Linguistics*, 30, 425-449.
- Halle, Morris & Alec Marantz (1994) 'Some Key Features of Distributed Morphology', *MIT Working Papers in Linguistics* 21.
- Heim, Irene (1988) 'On the Projection Problem for Presuppositions', in *Proceedings of the Second West Coast Conference on Formal Linguistics*. Reprinted in Davis, ed. *Pragmatics*.
- Heim, Irene (1991). 'Artikel und Definitheit.' In A. v. Stechow and D. Wunderlich (eds) *Handbuch der Semantik*. Berlin: de Gruyter, 1991.
- Heim, Irene (1991) Class hand-outs on 'Control' (Seminar taught by Heim & Higginbotham, Spring 1991): 'Interpretation of PRO' (Feb. 22), 'The first person' (March 8), and a hand-out on 'connectedness' (April 12).
- Heim, Irene (1994) 'Puzzling reflexive pronouns in *de se* reports', hand-out, Bielefeld Conference, March 1994.
- Heim, Irene (1994b) 'Comments on Abusch's Theory of Tense', in H. Kamp (ed.), *Ellipsis, Tense and Questions*, pp. 143-170, U. of Amsterdam.
- Higginbotham, James. 1989. 'Reference and Control'. *Rivista di Linguistica* 1, 2.
- Higginbotham, James (1995) 'Tensed Thoughts'. *Mind & Language*, 10, 3.
- Higginbotham, James 'Why is Sequence of Tense Obligatory?', hand-out of a talk given at Harvard on November 6th, 1998.
- Hockett, Charles F. (1966) 'What Algonquian is Really Like', *International Journal of American Linguistics*, Volume 32, 59-73.
- Huang, C.-T. James (1998) 'Long Distance Reflexives - An Overview', class hand-outs, Irvine.
- Hyman, Larry M., ed. (1979). *Aghem Grammatical Structure*. Southern California Occasional Papers in Linguistics No. 7
- Hyman, Larry M. & Bernard Comrie (1981) 'Logophoric Reference in Gokana', *Journal of African Languages and Linguistics* 3: 19-37
- Iatridou, Sabine (1994) 'On the Contribution of Conditional *Then*', *Natural Language Semantics* 2: 171-199
- Iatridou, Sabine (1998) 'The Grammatical Ingredients of Counterfactuality', ms., MIT
- Ippolito, Michela (1997) 'Reference Time and Tense Anaphora', ms., MIT.
- Israel, David & John Perry (1996) 'Where Monsters Dwell', in Seligman & Westerståhl, ed. *Logic, Language and Computation*, Volume 1.
- Jackson, Frank (1991) *Conditionals*, Oxford Readings in Philosophy
- Jäger, Siegfried (1971) *Der Konjunktiv in der deutschen Sprache der Gegenwart*, Max Hueber Verlag.
- Janssen, Theor & Wim van der Wurff, ed. (1996) *Reported Speech*, John Benjamins
- Kaplan, David (1990) 'Thoughts on Demonstratives', in ed. P. Yourgrau, *Demonstratives*, Oxford University Press, 1990.
- Kaplan, David (1977) 'Demonstratives', in *Themes from Kaplan*, ed. Almog/Perry/Wettstein, Oxford University Press, 1989
- Kaplan, David (1989) 'Afterthoughts', in *Themes from Kaplan*, ed. Almog/Perry/Wettstein, Oxford University Press, 1989

- Kitagawa, Yoshihisa (1991) 'Copying Identity', *Natural Language and Linguistic Theory*, 9.3.
- Kondrashov, D. & N. Kondrashova (1999). 'Double-access double-decker: Where semantics can get a free ride on syntax', hand-out, Themi Conference on Tense, Aspect and Mood.
- Koopman, Hilda & Dominique Sportiche (1989) 'Pronouns, Logical Variables, and Logophoricity in Abe', *Linguistic Inquiry*, 20: 4
- Kratzer, Angelika (1978) *Semantik der Rede*, Scriptor
- Kratzer, Angelika (1991) 'Conditionals', in A. von Stechow, D. Wunderlich (ed.) *Semantik: ein internationales Handbuch der zeitgenössischen Forschung*.
- Kratzer, Angelika (1991) 'Modality', in A. von Stechow, D. Wunderlich (ed.) *Semantik: ein internationales Handbuch der zeitgenössischen Forschung*.
- Kratzer, Angelika (1997) 'Impersonal Pronouns and Logophoricity'. Hand-out of a talk given at *Sinn und Bedeutung II*, Berlin, December 1997.
- Kratzer, Angelika (1998) 'More Structural Analogies Between Pronouns and Tenses', *Proceedings of SALT VIII*
- Kuno, Susumu (1972) 'Pronominalization, Reflexivization, and Direct Discourse' *Linguistic Inquiry* 3(2): 161-195
- Kuno, Susumu (1973) *The Structure of the Japanese Language*, MIT Press
- Kuno, Susumu (1987) *Functional Syntax*, University of Chicago Press
- Künne, Wolfgang & Ernest Sosa 'Deixis und Selbstbezug / Deixis and self-reference'
- Kusumoto, Kiyomi. 1998. 'Tenses as logophoric pronouns'. Hand-out of talk given at the MIT/UConn/UMass Semantics Workshop, October 31, 1998 (UConn)
- Larson, Richard K. & Peter Ludlow (1993) 'Interpreted Logical Forms' *Synthese* 95: 305-356. Reprinted in Ludlow 1997.
- Lazard, Gilbert (1992) *A Grammar of Contemporary Persian*, Mazda Publishers & Bibliotheca Persica
- Leslau, Wolf (1995). *Reference Grammar of Amharic*. Harrassowitz - Wiesbaden.
- Lewis, David (1970) 'General Semantics'. Reprinted in *Philosophical Papers*, Vol. I, Oxford University Press, 1983
- Lewis, David (1973) *Counterfactuals*, Harvard University Press
- Lewis, David (1975) 'Adverbs of Quantification', in Keenan (ed.) *Formal Semantics of Natural Language*, reprinted in Lewis 1998
- Lewis, David (1979) 'Attitudes De Dicto and De Se'. *The Philosophical Review* 88, 513-43. Reprinted in Lewis 1983
- Lewis, David (1979b) 'Scorekeeping in a Language Game'. *Journal of Philosophical Logic* 8, 339-359. Reprinted in Lewis 1983
- Lewis, David (1980) 'Index, Context and Content'. Reprinted in Lewis 1998
- Lewis, David (1983) *Philosophical Papers I*, Oxford University Press
- Lewis, David (1986a) *Philosophical Papers II*, Oxford University Press
- Lewis, David (1986b) *On the Plurality of Worlds*, Blackwell
- Lewis, David (1998) *Papers in Philosophical Logic*, Cambridge University Press
- Ludlow, Peter (1997) *Readings in the Philosophy of Language*, MIT Press.
- Morgan, Jerry (1970) 'On the Criterion of Identity for Noun Phrase Deletion', CLS 6.
- Ogihara, Toshiyuki (1996) *Tense, Attitudes, and Scope*. Kluwer
- Partee, Barbara (1973) 'Some Structural Analogies Between Tenses and Pronouns in English', *The Journal of Philosophy* 70, 601-609.
- Partee, Barbara (1984) 'Nominal and Temporal Anaphora', *Linguistics & Philosophy* 7, 243-286.

- Partee, Barbara (1989) 'Binding Implicit Variables in Quantified Contexts', CLS 25.
- Partee, Barbara (1991) 'Deictic and Anaphoric Pieces of Meaning', hand-out of a talk given at the ASL/LSA Conference on Logic and Linguistics, Santa Cruz, July 19-21, 1991.
- Perry, John (1977) 'Frege on Demonstratives', *Philosophical Review*, 86. Reprinted in Yourgrau 1990.
- Rebuschi, Georges (1997) 'Quirky Dependence: Discourse Pronouns and Predicate Ellipsis', in F. Corblin, D. Godard and J.-M. Marandin (eds.), *Empirical Issues in Formal Syntax and Semantics*, 171-191. Bern: Peter Lang.
- Reinhart, Tanya (1983) 'Point of View in Language - The Use of Parentheticals', in Gisa Rauh (ed.) *Essays on Deixis*, Gunter Narr Verlag Tübingen.
- Reinhart, Tanya (1991) 'Self-Representation'. Ms.
- Rescher, Nicholas & Alasdair Urquhart (1971) *Temporal Logic*, Springer.
- Roncador, Manfred von (1992) 'Types of Logophoric Marking in African Languages', *Journal of African Languages and Linguistics* 13: 163-182.
- Ross, John Robert (1970) 'On Declarative Sentences', in R. Jacobs & P Rosenbaum (eds), *Readings in English Transformational Grammar*
- Sag, Ivan (1976) *Deletion and Logical Form*, Doctoral Dissertation, MIT.
- Seligman, Jerry & Dag Westerståhl, ed. (1996) *Logic, Language and Computation* Volume 1, CLSI Publications.
- Sells, Peter (1987). 'Aspects of Logophoricity', *Linguistic Inquiry*, 18, 3: 445-479
- Sher, Gila (1991). *The Bounds of Logic*. MIT Press.
- Smyth, Herber Weir (1956) *Greek Grammar*, Harvard University Press
- Speas, Peggy (1999) 'Person and Point of View in Navajo Direct Discourse Complements', ms., University of Massachusetts, Amherst
- Stalnaker, Rober (1968) 'A Theory of Conditionals', reprinted in Jackson, ed. *Conditionals*
- Stalnaker, Rober (1975) 'Indicative Conditionals', reprinted in Jackson, ed. *Conditionals*
- Stalnaker, Rober (1978) 'Assertion', reprinted in Stalnaker 1999.
- Stalnaker, Robert (1981) 'Indexical Belief', *Synthese* 49
- Stalnaker, Rober (1984) *Inquiry*, MIT Press
- Stalnaker, Rober (1999) *Context and Content*, Oxford University Press.
- Stechow, Arnim von (1982) 'Structured Propositions', Papier Nr. 59, SFB 99, Konstanz
- Stechow, Arnim von (1984) 'Structured Propositions and Essential Indexicals', in F. Landman, F. Veltman (ed) *Varieties of Formal Semantics*, Dordrecht.
- Steinberg, Günter (1971) *Erlebte Rede. Ihre Eigenart und ihre Formen in neuerer deutscher, französischer und englischer Erzählliteratur*. Verlag Alfred Kümmerle, Göppingen.
- Stone, Matthew (1997) 'The Anaphoric Parallel between Modality and Tense', IRCS Report 97-06, University of Pennsylvania
- Stowell, Tim 'The Phrase Structure of Tense', in Rooryck & Zaring, ed. *Phrase Structure and the Lexicon*, Kluwer.
- Stowell, Tim 'What Do the Present and Past Tenses Mean?', in Bertinetto, Bianchi, Higginbotham & Squartini (eds) *Temporal Reference, Aspect and Actionality*. Vol. 1: Semantic and Syntactic Perspectives. Rosenberg & Sellier.
- Tedeschi, Philip J. (1981) 'Some Evidence for a Branching-Futures Semantic Model', in Tedeschi, Philip J. & Annie Zaenen, ed. *Tense and Aspect*
- Tedeschi, Philip J. & Annie Zaenen (1981) *Tense and Aspect*, Volume 14 of *Syntax and Semantics*
- Thomas, Elaine (1978). *A Grammatical Description of the Engenni Language*. Summer Institute of Linguistics Publication Number 60.

- Thomason, Richmond H. (1970) 'Indeterminist time and truth-value gaps', *Theoria*, 36, 264-281
- von Stechow (1975) 'On the Proper Treatment of Tense', *SALT V*, 362-386.
- Wolfart, H. Christoph & Janet F. Carroll (1981) *Meet Cree: A Guide to the Cree Language*, University of Nebraska Press
- Yourgrau, Palle [ed.] (1990) *Demonstratives*. Oxford Readings in Philosophy.
- Zimmermann, Thomas Ede (1991) 'Kontextabhängigkeit', in A. von Stechow, D. Wunderlich (ed.) *Semantik: ein internationales Handbuch der zeitgenössischen Forschung*.

Notes

¹There is a still more general way of stating the hypothesis: 'The interpretive system is domain-neutral' - every interpretable feature and every interpretive rule exists in every sortal domain (individuals, times, worlds, and probably events as well - although it would take a lot of work to show that events exist *in addition* to times).

²Note that Partee's discovery is normally stated as an analogy between tense and *pronouns*. But one could suggest instead that the correct analogy is between tense and *agreement markers in pro-drop languages*. In many cases, this won't make a difference - agreement markers in pro-drop languages *can* always behave as pronouns. But they have other uses in addition - they can, unlike (standard) pronouns, cooccur with a local quantifier ('*Someone HE has arrived' [English] vs. 'Qualcuno è arrivato' [Italian]). And of course this is also the case of tenses ('At some point the little cat died'). In what follows we rely on an analogy between tense and *person*, which is compatible both with Partee's statement and with the alternative we just considered.

³More technically: by replacing (sorted) constants or variables ranging over individuals with (sorted) constants or variables ranging over times or worlds.

⁴We write 'tense/mood' when either (i) we do not know how to distinguish the two (as will be the case in the study of logophoric tense/mood), or else when (ii) the phenomenon we examine appears to exist only with tense (Free Indirect Discourse).

⁵The term will be defined later. For present purposes an intuitive understanding will be enough: an element is indexical if its denotation depends on the context of speech.

⁶Some on-going work by Kusumoto might be somewhat more directly related to the present attempt. Unfortunately I have only seen a hand-out by her (cited in the references).

⁷The use of the logophoric form is obligatory in Ewe and Gokana, and optional in German. We will have nothing to say about this difference.

⁸This will be refined when we study in detail 1st and 2nd person pronouns.

⁹Her claim is in fact weaker - she suggests that 'might' and 'ought' can be shifted in intensional contexts.

¹⁰Abusch claims that 'John married a woman who might HAVE become rich' is appropriate in that context. But apparently this judgment is not shared by all speaker (D. Pesetsky, p.c.).

¹¹K. von Stechow informs me that there is a prefiguration of this in Groenendijk & Stokhof's 1975 paper [*Theoretical Linguistics* No 1/2, 1975, p. 70].

¹²As noted in Ogiwara 1996 (p. 132) [who in turn credits Heim], Sequence of Tense can be triggered even in the absence of an overt past tense. It is enough for it to be understood that the attitude occurred in the past, as in the following examples (Ogiwara's (64)):

- (i) a. John's (earlier) claim that he was innocent is well-known.
- b. I still recall John's public announcement that he had cancer.
- c. This contradicts John's (earlier) claim that Mary would win the prize.

Here there is no matrix past tense, only a **noun** phrase (e.g. 'John's (earlier) claim'). But the discourse situation makes it clear that the claim itself occurred in the past, and this is enough to trigger Sequence of Tense in the embedded clause. (Abusch 1997 cites similar examples). Cf. Chapter 4 for a discussion.

¹³The terminology is rather unfortunate, but since it is widely accepted we will stick to it. 'Indexicality' should really be called 'contextuality', since we are interested in the dependency of an

expression on a coordinate of a *context*. An indexical expression in this sense is one which is evaluated with respect to a context, *not* with respect to an index (in the sense of 'point of evaluation'). Apparently it is only recently that the term 'index' has come to be used to refer a point of evaluation; in more traditional usage it denoted what is otherwise called a 'context'.

¹⁴More pedantically, we can give the following criterion:

(i) Truth-conditional Criterion

An element E of a sentence is indexically dependent on a coordinate $i \in$ [[author, hearer, time, world]] of the speech situation C just in case E uttered in C may have a different semantic value from E uttered in C', where C' is identical to C except for the coordinate i.

$\exists C \exists C' \exists i \forall j \in$ [[author, hearer, time, world] - {i}] $j(C)=j(C') \ \& \ [[E]](C) \neq [[E]](C')$

¹⁵Partee 1991 observes that an overt pronominal cannot always be inserted in these environments. She comments on the following examples [her (4)]:

- (i) a. Every man who stole a car abandoned it 2 hours later.
- b. Every man who stole a car abandoned it within 50 miles / 50 miles away.

"We cannot substitute 'later than that', 'within 50 miles of there', '50 miles away from there' in [(ia-b)] as they stand, but if we added a simple 'at some time' or 'somewhere' in the respective antecedent relative clauses then we could". [It is not clear how strong these judgments are. Thus D. Pesetsky (p.c.) reports the following contrasts: ?later than that, *within 50 miles of there, Ok 50 miles from there].

As Partee shows, however, implicit anaphors share many properties of overt pronominals - for instance they can yield Weak Cross-Over effects:

- (ii) a. From five feet away I tried to toss a peanut to the pigeon.
- b. #? From five feet away I tried to toss a peanut to every pigeon.

Whatever natural class encompasses both overt and implicit anaphors is what we designate by the word 'pronominals'. The difference between the two subclasses is not relevant for us at this point.

¹⁶Modern Persian presents an interesting contrast. Although it patterns with Amharic and Chaha in that it allows an indexical to be shifted under an attitude operator, wh-extraction is blocked in case the indexical is shifted. This suggests that a complement clause may appear in direct discourse despite the presence of a complementizer. Consider the following facts (Karine Megerdooian, p.c):

- (i) goft (ke) xAham Amad
said that I-will come-subj

- 1. He said he will come
- 2. He said I will come

At this point Interpretation 1. might be analyzed in one of two ways:

(a) (i) is analyzed as a case of direct discourse, despite the (optional) presence of the complementizer;

or

(b) (i) is a case of indirect discourse, and the embedded 'I' is a shifted indexical.

Persian is minimally different from Amharic (to be discussed in greater detail below) in that it displays evidence for (a) (the direct discourse alternative) and against (b). The argument is the following: in case a wh-element is extracted out of the embedded clause (something which is never possible out of a quotation), interpretation 1. becomes unavailable:

- (ii) #be Soma xabar dad ke koja xaham raft?
to you information gave that where aux-FUT-1sg go
‘Hej told you where hej was going’ [Persian, Lazard 1992 - given by Lazard as Ok]]

The sentence is found to be deviant by my informant, which suggests that for her (i) on interpretation 1. is analyzed as a direct discourse (i.e. literally: He said that “I will come”). Interestingly, Lazard 1992 cites this sentence as grammatical (he quotes it from literary sources). Maybe at some stage Persian had Amharic-style (shiftable) indexicals, which then got lost, at least for some speakers. Thus the appearance of shifting remains in (i), but this is only because speakers can analyze it as a case of quotation, from which, however, wh-extraction is always impossible.

¹⁷Unfortunately the situation appears to be more complicated than is implied in our presentation. There are cases that do not allow plural features to percolate from the matrix subject to the subject of the embedded clause [D. Petros, p.c.]:

- (i) a. **Situation:** John and Peter each said: ‘I am better’ [each was comparing himself to the other]

b. **Report:**

1. **False:** John-Inna Peter [INNa Inbəlt’allən] alu
John and Peter [we are-better] they-said

The sentence is true if either (a) John and Peter claimed that I (the speaker of the report) and someone else are better, or (b) John and Peter’s claim was of the form: ‘We [i.e. John + Peter] are better’.

2. **True:** John-Inna Peter Iyyandandaccaw [Ine Ibəlt’alləxu Ine Ibəlt’alləxu] alu
John and Peter each I am-better I am-better they-said

2. is most probably a case of direct quotation with each of the embedded elements corresponding to one of the claims that were made (i.e. John said ‘I am better’ and Peter also said ‘I am better’). Furthermore, when an element is extracted out of the embedded clause (which should force an indirect discourse reading) the structure in 2. becomes ungrammatical [D. Petros, p.c.]:

- (ii) **Situation:** John said: ‘I like X’, and Peter said: ‘I like Y’. I want to know what X and Y are.

- a. mIn Inwəddallən alu
what we-love they-said
‘What did they say they liked?’
- b. *mIn Iwəddalləku (Iwəddalləku) alu
what I-love (I-love) they-said

Note also that (iib.) remains ungrammatical when the embedded element is *not* repeated. This suggests that in case of reported speech the embedded subject inherits the number features of the matrix subject.

A further question is why (iib1) should be false. The contrast with (i) appears to be completely mysterious. But the problem might have nothing to do with indexicality. Notice that in English or in French the situation in (iia) is also very hard to report (R. Bhatt, p.c.):

- (iii) a. ?? John and Peter (each) said that they are better (than the other)
b. *John and Peter (each)said that he is better (than the other)
a’. ??(?) Jean et Pierre ont (chacun) dit qu’ils étaient meilleurs (que l’autre)
b’. *Jean et Pierre ont (chacun) dit qu’il était meilleurs (que l’autre)

[Note that the difference between a' and b' is not solely orthographic - 'ils étaient' is pronounced (in my dialect) [ilzete], while 'il était' is [ilete] (other dialects would have [ilzete] and [ilete] respectively)]. Apparently (iv a) improves when 'they' is stressed (D. Pesetsky, p.c.)

One possible interpretation of the facts in (ib1) is that (a) one *never* likes to report a situation like (ia) with a plural in the embedded clause, be it in English or in Amharic (for whatever reason this is). Hence (b) the Amharic speaker assigns the sentence one of its two grammatical readings (we=speaker of the report + somebody else, or we=John+Peter, on the assumption that their claim was of the form 'We are better'), and the sentence is judged to be false.

Clearly, more empirical work is needed here.

¹⁸Just as 'he' can be used without a linguistic antecedent if some male individual is sufficiently salient in the speech situation, 'two days later' can be evaluated with respect to any which is salient enough, even if does not appear in the previous discourse. For example the following words could appear at the end of a movie: 'John Smith died two days later'. It would be understood that the point of reference was the last scene of the film.

¹⁹Note that there is a minimal difference (which I do not understand) between 'two days later' and 'later': although both are anaphoric, only the latter can take the utterance time as an antecedent.

²⁰The term 'logophoric' has been applied to a variety of phenomena in recent linguistic theorizing. We use it in its original sense.

²¹Clements cites interpretive evidence for this; the presence of the logophoric pronoun in the adjunct appears to correlate with a purpose (rather than a consecutive) reading:

(i) a. $\text{q}\epsilon\text{vi-a}$ xo tohehe be $\text{y}\grave{\epsilon}\text{-a-ga-da}$ alakpa ake o
child-D receive punishment so that LOG-T-P-tell lie again NEG
 'The child_i received punishment so that he_j wouldn't tell lies again' [Clements's (50)]

b. $\text{q}\epsilon\text{vi-a}$ xo tohehe be $\text{w}\grave{\delta}\text{-a-ga-da}$ alakpa ake o
child-D receive punishment so that pro-T-P-tell lie again NEG
 'The child_i received punishment so that he_j wouldn't tell lies again' [Clements's (51)]

'There is a rather striking difference in meaning between these two versions', Clements observes (p. 161). 'In [a], we understand by the use of 'yè' that the child voluntarily received punishment, in the belief that this would cure him of his unfaithfulness. (While some speakers find [a] somewhat strange, they attribute this to the unlikelihood of such a situation ever occurring.) Although [b] may be interpreted in the same way as [a], its more likely interpretation is that the child was punished against his will, in the belief (on the part of someone else) that this would cure him of telling lies. These differences in interpretation are consistent with our general characterization of the use of logophoric forms: the use of 'yè' in [a] informs us that the context in which it occurs (the purpose clause) designates an intention on the part of its antecedent.'

²²Given our semantics for propositional attitudes, it is not sufficient to claim that purpose clauses are intensional. We must show that they actually quantify over contexts. [There is nothing in our general theory that disallows quantifiers over possible worlds, and presumably this is what modals normally are, just as standard theories claim.] We can in principle establish the point by showing that 'in two days' can be shifted in a purpose clause. Unfortunately I am not sure how convincing the data are; I find the French examples rather degraded, although they are still better than the extensional cases [note that French 'dans deux jours' can mean 'in two days' with the sense of 'exactly two days later', not 'within two days']:

- (i) a. *Le 12 juillet Jean a travaillé beaucoup plus que d'habitude, dans le but d'être libre deux jours plus tard.*
 'On July 12 Jean worked far more than usual, in order to (lit. in the goal to) be free two days later'
- b. *?*Le 12 juillet Jean a travaillé beaucoup plus que d'habitude, dans le but d'être libre dans deux jours.*
 'On July 12 Jean worked far more than usual, in order to (lit. in the goal to) be free in two days'
- c. (?) *Le 12 juillet Jean a décidé qu'il partirait dans deux jours / deux jours plus tard*
 'On July 12 Jean decided that he would leave in two days / two days later'
- d. **Le 12 juillet Jean a travaillé beaucoup plus que d'habitude, et est parti dans deux jours*
 'On July 12 Jean worked far more than usual, and left in two days'
- e. *Le 12 juillet Jean a travaillé beaucoup plus que d'habitude, et est part deux jours plus tard*
 'On July 12 Jean worked far more than usual, and left two days later'

I do not know why b. is so degraded.

²³One could try to argue that (7) is independently ruled out because (as a number of researchers have suggested) there is a subjecthood condition on the use of 'yè'. This may be true for some speakers, but not for all. Clements gives the following examples:

(8) Ewe: no subjecthood condition (at least not for all speakers)

me-se tso kofi gbɔ be yè-xɔ nunana
pro-hear from Kofi side that LOG-receive gift [Clements's (44)]

'I hear from Kofi_i that he_j had received a gift' [note that a 1st person pronoun can never be the 'antecedent' of 'yè']

Direct discourse: I hear from Kofi: 'I have received a gift' [presumably]

(8') Gokana: no subjecthood condition

à kyẽ lébàrè kɔ aé dɔ-è
it angers Lebare that he fell-LOG [H & C's (4b)]
 'It angers Lebare_i that he_j fell'

²⁴Here are a few examples, provided by I. Heim and M. Hackl.

(i) Mathematical examples: *Sei A ein Dreieck*, etc. ['Let A be a triangle...']. For M. Hackl these examples sound awkward in his High German register (although he clearly does accept the Konjunktiv I when it is embedded under an attitude verb). An important question is whether, for those speakers who accept the mathematical example, the pattern is productive (can they say: 'Es habe ein Dreieck zwei gleich lange Seiten' ('Let a triangle have two sides of equal length'), etc.

(ii) 'es sei denn' = unless

'Ich werde morgen nach Providence fahren, es sei denn mein Auto funktioniert nicht mehr'
 I'll go to Providence tomorrow, unless my car doesn't work any more.

Clearly this pattern is not productive, since there is not way 'sei' could be replaced with any other verb.

(iii) a. Sei es heute oder morgen ...
Be it today or tomorrow

b. *Habe der Peter Fieber oder nicht
Have the Peter fever or not

Here again the pattern with 'be' in the Konjunktiv I cannot be replicated with other verbs.

(iv) Es sei wie es sei, stirbt die Kuh, bleibt das Heu (M. Hackl, p.c.)

²⁵Clements cites the following example, 'from an oral retelling of the tale "The Monkeys and the Moon":

(i)	wo ame etãa	woqui veviẽ be	yèwoaɖe	dyinua
	<i>the three</i>	<i>of them they planned firmly that</i>	<i>LOG would take out</i>	<i>the moon</i>
tsa me.	ne yèwodji tsa me ko a,	yèwoakœ		
<i>from the water.</i>	<i>when LOG had taken it out of the water,</i>	<i>LOG would lift it</i>		
wðano yewo nɔts yèwo si,	ale be wðano dɔdɔm	na	yèwo	yɛsiaɣi le zã me.
<i>(so that) it would be LOG's,</i>	<i>so that it would be shining</i>	<i>for</i>	<i>LOG</i>	<i>always in the night.</i>
ne zã do ko a,	dyinu dɔdɔm	na yèwo,	ke vivityi	
<i>when night fell,</i>	<i>the moon would be shining</i>	<i>for LOG,</i>	<i>and darkness</i>	
mega dodoge	na yèwo,	yɛaɖekeyi o.		
<i>would not come again</i>	<i>for LOG</i>	<i>ever.</i>		

'The three of them_i resolved that they_j would take the moon out of the water. When they_i had taken it out of the water, they_j would lift it up so that it would be theirs_j, so that it would be shining for them_i always in the night. When night came, the moon would be shining for them_i, and darkness would never again fall on them_j.' [Clements's (72) p. 170]

²⁶This is a translation of the French term, 'discours (style) indirect libre'. The German term is 'erlebte Rede'.

²⁷Dahlstrom's footnote: 'The term "obviatif" was coined by Cuoq 1866 for this Algonquian grammatical category'.

²⁸The correspondence between 'salience' and temporal ordering has been used before. In *Counterfactuals*, Lewis suggested that his logic for conditionals could be extended to definite descriptions and (his equivalent of) when-clauses. Lewis's idea was that there was a structural analogy between the notion 'closer to' in the world domain, 'more recent than' in the time domain, and 'more salient than' in the domain of reference to individuals. A simplified version of his system would treat if-clauses as definite descriptions of worlds and when-clauses as definite descriptions of times. This would yield the following analysis:

if p: the closest possible world such that p

when-next p: the next time that p

when-last p: the last time that p

the p: the most salient individual that has the property p

We leave the following questions for future research:

(i) Is the notion of 'salience' relevant for obviation the same as what is needed in the analysis of definiteness?

(ii) Can Lewis's ideas be implemented in such as to give a further argument for the correspondence between salience hierarchies and temporal ordering?

²⁹"If the possessed noun is animate, then a nonlocal animate possessor and the possessed noun must be located at different points on the obviation scale; and it is a general principle in Algonquian that the possessor in such cases is 'closer' than the possessed entity. This overrides other factors that might control the assignment of various nonlocal animate entities to the various points on the scale. Thus, for *his father*, *he* can be proximate and *father* obviative, or *he* nearer obviative and *father* further obviative; but there is no way for *father* to be proximate and *he* to be obviative. Actually, in Potawatomi there are only two distinct forms: /ʔos.un/ *his father* with possessor proximate and possessed obviative, and /ʔos.nun/ with possessor indifferently proximate or obviative and possessed further obviative; of these two, the latter is rare and perhaps avoided as 'awkward'." [Hockett 1966 p. 64]

³⁰See also Hockett 1966 p. 60:

'The basic principle breaks down when the machinery for the differentiation does not exist. In theory, 'John saw Bill, Bill's father, and Bill's father's dog' would call for four different points, other than local, on the obviation scale; but there is machinery only for three, so that 'father' and 'dog' would not be overtly marked as distinct in category. Even when the machinery does exist, the more delicate distinctions, calling for more elaborate machinery, are sometimes omitted; or else what is to be said is recast into two or more successive spans instead of being put into one, with a shift of focus from one to the next.'

³¹Unlike Kaplan's, Stalnaker's Characters are defined as functions from *worlds* to propositions rather than as functions from *contexts* to propositions (where 'contexts' should be understood in our technical sense, as tuples $\langle x, (y), t, w \rangle$ which include an author and, optionally, a hearer coordinate); we disregard this difference here

³²In 'The First Person', Anscombe writes:

'... what is in question is not the ordinary reflexive pronoun, but a peculiar reflexive, which has to be explained in terms of 'I'. It is the reflexive called by grammarians the 'indirect reflexive' and there are languages (Greek, for example) in which there is a special form for it'.

She adds in a footnote (fn. 4):

'he, hou, hoi'. See Thucydides II. 13. The form is rare. Credit for discerning the indirect reflexive in English, which does not have a distinct form for it, belongs in the present day to H.-N. Castañeda in 'On the Logic of Self-Knowledge', *Noûs*, 1 (1967), 9-21. But his presentation is excessively complicated and I believe it has not attracted enough attention to the substantive point'. Anscombe, 1975, p. 141.

In linguistic terms, the 'indirect reflexives' of Latin and Greek are logophoric pronouns, or at least they have logophoric uses. Here is what Nick Clements had to say about them in his study of logophoric pronouns in Ewe [Clements 1975 p. 142]:

"What may be termed the *logophoric use* of reflexive pronouns has been observed in a number of languages outside Africa, and has long been documented for Latin and classical Greek, where it is usually termed 'indirect reflexivization'. The indirect reflexive, like the logophoric pronoun of Ewe, permits a speaker to avoid ambiguity of reference in many cases. Woodcock (1959, 24) cites as an example the ambiguous English sentence (6) and its unambiguous Latin analogue (7), in which the reflexive pronoun *sibi* refers uniquely to Cicero, and the nonreflexive personal pronoun *eum* to someone else:

(6) Mr. Smith said that he had insulted him

(7) Cicero dixit eum sibi maledixisse
'Ciceroj said that he_k (eum) had insulted him_j (sibi)' "

Clements concludes (p. 144):

"... the logophoric pronoun of Latin differs primarily from the logophoric pronoun of Ewe not in function, but rather in the fact that in Latin, it is homophonous with the reflexive pronoun."

About Ancient Greek, Clements writes (p. 144):

"The reflexive pronouns of classical Greek are employed, like those of Latin, in logophoric function, although their use is more flexible in some respects. (...) Of particular interest here are the archaic reflexive pronouns 'he' and 'sphas' retained in Attic, where they are reserved, in general, for 'indirect' reflexivization, contrasting with the newer forms which are used for 'direct' reflexivization (Humbert 1972, 63)."

After discussing several possible analogues of Ewe logophoric pronouns, Clements concludes on p. 147:

"It is therefore with the 'indirect reflexive pronouns' of Latin, classical Greek and other languages that the logophoric pronouns have the closest affinity. The evidence they provide for the role of discourse factors in grammar places the study of 'indirect reflexives' in a new light. As we saw earlier in (4) and (5) (and as we see in more detail in section 3, below), the logophoric pronoun of Ewe is morphologically unrelated to the reflexive form, and these two forms are quite dissimilar in terms of the syntactic and semantic conditions governing their occurrence. We have no a priori reason, therefore, to expect the indirect reflexive pronouns of Latin and Greek to share any important grammatical functions or other characteristics with the 'direct reflexive' forms. That the logophoric and reflexive pronouns of Latin and Greek are in fact homophonous, and share certain distributional features, can be attributed to diachronic factors (the assignment of a new grammatical function to an already-available grammatical form), and need not lead us to impose upon one form the analysis appropriate to the other."

³⁹This is not to say that the observation that De Se situations are compatible with sentences like 'Lingens thinks he is in Stanford library' does not constrain the semantics of attitudes - our point is simply that it does not by itself entail that the *object* of an attitude operator couldn't be a standard proposition. But some proposition-based theories are certainly falsified by the observation. Consider for instance a standard possible worlds semantics rendition of Kaplan's proposal for Quantifying In:

(i) 'Ralph believes (De Re) that Ortcutt is a spy' is true in w^* if and only if
 $\exists \alpha \langle e, \langle w, t \rangle \rangle [R(\alpha, \text{Ortcutt}, \text{Ralph}) \ \& \ \text{Ralph believes in } w^* \text{ that } [\lambda w (\exists x: \alpha(x) (w)) \text{ is a spy in } w]$

where $R(\alpha, \text{Ortcutt}, \text{Ralph})$ if and only if

I. $\text{Ortcutt} = \lambda x: \alpha(x)(w^*)$

II. α is a description of Ortcutt for Ralph

III. α is sufficiently vivid

The problem is that in a pure De Se situation, there might be no description whatsoever which satisfies these conditions. Suppose Lingens (i) knows everything there is to know about the world (he's read all the books), but (ii) has no idea who he is, except that (iii) he would assent to the following: 'Whoever I am, I am an amnesiac!' The situation does not appear to be contradictory; but there is no way the possible worlds version of Kaplan's Quantifying In theory can yield a De Re reading compatible with it. All the theory has to offer is the following:

(ii) $\exists \alpha \langle e, \langle w, t \rangle \rangle [R(\alpha, \text{Lingens}, \text{Lingens}) \ \& \ \text{Lingens believes in } w^* \text{ that } \lambda w [(1x: \alpha(x, w)) \text{ is an amnesiac in } w]$

where $R(\alpha, \text{Lingens}, \text{Lingens})$ if and only if

I. $\text{Lingens} = 1x: \alpha(x)(w^*)$

II. α is a description of Lingens for Lingens

III. α is sufficiently vivid

Since by assumption Lingens knows everything there is to know about the world, he can determine the value of the actual world w^* ; which implies that he can determine who he is by computing the value of $1x: \alpha(x)(w^*)$. But this contradicts our assumption! The problem is that Lingens's belief about himself is essentially indexical, so that no (non-indexical) description can replace 'I' in the statement of his belief. But this is precisely what the above semantics does not allow for.

Note, on the other hand, that a quotational version of Kaplan's semantics for Quantifying In could be compatible with a pure De Se situation:

(iii) 'Ralph believes (De Re) that Ortcutt is a spy' is true in if and only if

$\exists \alpha [R(\alpha, \text{Ortcutt}, \text{Ralph}) \ \& \ \text{Ralph believes: "}\alpha \text{ is a spy"}]$

where $R(\alpha, \text{Ortcutt}, \text{Ralph})$ if and only if

I. α denotes Ortcutt

II. α is a name of Ortcutt for Ralph

III. α is sufficiently vivid

If the context of speech/thought can be taken as a parameter, 'I' will denote Lingens, and will presumably be sufficiently vivid. The following conditions will thus be satisfied by the pure De Se situation:

(iv) 'Lingens believes that he is an amnesiac' is true in if and only if

$\exists \alpha [R(\alpha, \text{Lingens}, \text{Lingens}) \ \& \ \text{Lingens believes: "}\alpha \text{ is an amnesiac"}]$

where $R(\alpha, \text{Lingens}, \text{Lingens})$ if and only if

I. α denotes Lingens

II. α is a name of Lingens for Lingens

III. α is sufficiently vivid

In the pure De Se situation, we can just take $\alpha = 'I'$, which satisfies all the requirements.

³⁴Here is Kaplan's proposal in paragraph XX of *Demonstratives* ('Adding 'Says''):

"What is special and different about the present approach is the attempt to use the distinction between direct and indirect discourse to match the distinction between character and content. Thus when you wonder, 'Is that me?', it is correct to report you as having wondered whether you are yourself. These transformations are traced to the indexical form of your inner direct discourse rather than to any particular referential intentions. The idea is that the full analysis of indirect discourse includes

mention of the suppressed character of the direct discourse event which the indirect discourse reports, thus:

(i) $\exists c, C$ [c is a context & C is a character & x is the agent of c & x direct-discourse-verb C at the time t of c & the content of C in c is that...]

approximates a full analysis of

(ii) x indirect-discourse-verb that ... at t ." Kaplan, *Demonstratives*, p. 554.

[It is not clear whether (i) should be interpreted literally - a direct discourse verb (e.g. 'say' in: John says: 'I am a hero') is presumably a relation between an individual and a linguistic object (maybe the concatenation of the phonemes of the quoted utterance, maybe something more complex) rather than between an individual and a function from contexts to propositions. But this does not matter for Kaplan's purposes - just introduce a new relation 'say*' which corresponds to what Kaplan calls a 'direct discourse verb'; where C is a character, 'say*' is defined as:
say*(John, C) := $\exists S$ S is a sentence & character(S)= C & say(John, S)
where 'say' is a direct discourse verb in the standard, non-Kaplanian sense.]

³⁵ Here is Morgan's original example:

"Suppose that the baseball player Ernie Banks gets beamed, develops amnesia, and is taken to the hospital, where I am his doctor. He doesn't know his name. I, his doctor, know who he is, but I don't tell him. I observe his behavior over a period of time while he's in the hospital with no identity. During this time, he reads in the newspaper about a baseball player named Ernie Banks. He decides he likes Ernie Banks, and would like him to leave Chicago and go to New York to play for the Mets. I the doctor want to report this behavior of my patient Ernie Banks. Consider (5) through (7) in light of this situation.

- (5a) Ernie Banks wants [Ernie Banks to leave Chicago]
- (5b) Ernie Banks wants to leave Chicago.
- (6a) Ernie Banks would like [Ernie Banks to play for the Mets]
- (6b) Ernie Banks would like to play for the Mets
- (7a) Ernie Banks hopes for [Ernie Banks to move to New York]
- (7b) Ernie Banks hopes to move to New York."

³⁶ As was said earlier, the connection between De Se and indexicality was apparent from the beginning in the philosophy of mind, but the insight was lost in linguistic theories of De Se readings. The paradigm of the solution offered by Chierchia was that of the bound variable: a pronoun is read De Se just in case it is bound by a λ -operator in the embedded clause. PRO can *only* be bound by such an operator, while for 'he' this is optional. In his system, the connection between De Se and indexicality was lost for two reasons:

(i) Chierchia has no account of indexicality, and thus cannot draw the relevant connection.

(ii) He has no way to single out a class of elements that can only be bound by a coordinate of an embedded context (the terminology is ours, of course). In fact his theory entailed that *attitude environments are not special*. For Chierchia, there are just two classes of elements: (a) those, like PRO or Italian 'proprio', which *must* be bound by a λ -operator, and (b) those, like 'he', which can but do not have to be bound by such an operator. However *λ -operators do not only occur under attitude operators*. They are compatible with any matrix verb that can be followed by a Control structure (e.g. 'force', which is not an attitude verb)³⁶. As a consequence, *Chierchia has no way of defining a class of lexical elements which, like Ewe logophoric pronouns, can only occur in an attitude environment*. [This was a virtue of his theory given the facts that he considered, but it becomes a flaw when the pool of data is

enlarged]. As a consequence, the category of an all-purpose indexical ('in two days') can simply not be defined in Chierchia's system.

By contrast, Kratzer 1997 observes that the category of a 'De Se pronoun' cannot be dispensed with: she cites the case of logophoric pronouns in the West African languages, and further notes that German 'man' (on its inclusive reading) must refer to a group that includes the author of the actual or of a reported speech act. Kratzer posits a feature [log] which is introduced by what she calls the 'logophoric λ -operator'. She hints at a possible unification of the indexical and of the logophoric uses of inclusive 'man' 'within a dynamic, context-change framework'. However she does not provide any treatment of indexicality.

Finally, Heim 1991 (hand-out on 'The First Peron') sketches a system in which indexicals, like De Se pronouns, are bound by an operator in Comp. The crucial move is to posit that not just embedded clauses, but also matrix clauses can contain a λ -operator in their complementizer position. [Heim notes that there is a 'premonition' of this proposal in Koopman & Sportiche 1989, and further observes a similarity between her proposal and Ross's performative analysis].

Given the sketchiness of the latter proposals it is rather idle to speculate on the various possibilities there are to handle the generalizations presented in Chapter 1 within these systems. However the following points should be kept in mind:

(i) Heim's system relies on abstraction over *single variables* rather than over entire contexts, as in the system developed here. In our system it is possible to draw a distinction between 'tomorrow' (which is dependent on an entire context) and 'I' (which is coindexed with the author coordinate of a matrix context). This distinction plays an important role in the formalization of Free Indirect Discourse, where those elements pattern together. It is unclear how this could be done in the system sketched by Heim.

(ii) Abstraction over entire contexts has the advantage of predicting that *an operator that can shift some coordinate of a context* (e.g. the author coordinate) *must also shift other coordinates* (i.e. the hearer, time and world coordinates). This appears to be correct: attitude operators are the only elements that can shift indexicals, but they appear to do this for *any* sort of indexical (although the morphological reflex of this might not be observable in a single language - Russian shows that tense can be shifted, while Amharic shows that 'I' can be. But it is the same class of operators that can do the shifting in both languages). It is unclear how a similar prediction could be made within Heim's system.

³⁷As far as I know our theory of all-purpose indexicals is new - for the simple reason that the very existence of such indexicals has not been acknowledged in the theoretical literature. On the other hand the issue has occasionally been discussed in the typological literature, but to my knowledge no connection has been made with issues of formal semantics [e.g. in Anderson & Keenan 1985].

³⁸We could have defined 'in two days' and 'tomorrow' as functions that just take a time variable as argument, with the following well-formedness constraints:

Ok tomorrow(T)

* tomorrow(t)

Ok in-two-days(T)

Ok in-two-days(t)

This, however, makes incorrect predictions. There is nothing in this system that forces 'in two days' to be dependent on the time coordinate of a *context* [this definition makes it identical to 'later', which can indeed take any time variable as argument]. We could keep these definitions if we stipulated that there are not two, but three sorts of time variables:

T appears only as a coordinate of a matrix context

t appears only as a coordinate of an embedded context

d appears in all other environments

But this would clearly complicated the system. Thus the definition of ‘tomorrow’ and ‘in two days’ in terms of entire contexts has the advantage of forcing them to be indexical rather than anaphoric.

³⁹If our theory is correct, attitudes as they are represented in natural language cannot be construed as ‘egocentric’ - the center is the speech act rather than any sort of ‘ego’, ‘Ich’, etc. It is only in the case a thought act is reported that the hearer-coordinate is missing - which gives rise to apparently ‘egocentric’ representations like: Smith hopes $\lambda \langle x_i, t, w \rangle$ PRO_i to be elected. Whenever a speech act is reported, on the other hand, the hearer coordinate must be used as well:

⁴⁰“But now we should remind ourselves of the following facts about actual utterances and the contexts in which they are produced:

- One might not know who the agent of *c* is.
- One might not know when the time of *c* is.
- One might not know what the place of *c* is.
- One might not know what the world of *c* is.

Indeed, a speaker himself might be ignorant of the fact that he was the speaker of a given utterance. Consider the case of echoes, especially as produced at a famous and much-visited location. So given a type for an utterance, that is, given a sentence Φ , other contexts for Φ are epistemic alternatives. To see what may involved here, let us return to a simple double index account, in which the basic indices are just worlds. Here the ‘context’ index would represent the epistemic perspective of the agent and the circumstance index would, as usual, represent the world about which the knowledge claims are made. The clause for K (now suppressing indexing by agent) would be as follows:

- $w \models_v K\Phi$ iff $\forall w', v': \langle w, v \rangle R_K \langle w', v' \rangle \rightarrow w' \models_{v'} \Phi$

Notice that this operator involves quantification over contexts or generalized indices. It is a non-benign monster.

What would this look like in LD [=Kaplan’s Logic of Demonstratives -P.S.]? In conformity with Kaplan’s restriction, and supposing for simplicity that indices proper -circumstances- are just worlds, all he would allow us is this:

- $cw \models K\Phi$ iff $\forall w': w' R_K w \rightarrow cw' \models \Phi$

But to capture the facts about ignorance, what we need is rather more like this:

- $cw \models K\Phi$ iff $\forall c', w': \langle c, w \rangle R_K \langle c', w' \rangle \rightarrow c'w' \models \Phi$; where $c' = \langle c'_a, c'_t, c'_p, c'_w \rangle$.

This, of course, is monstrous.

In sum:

- Perhaps there is something right about Kaplan’s prohibition, but it is not quite right. Perhaps there could not be pure modal monsters, but there can be epistemic (and deontic, etc.) monsters.
- Double indexing has no explanation of the lack of modal monsters; Kaplan’s theory does not allow the epistemic ones.”

[Perry & Israel 1996, pp. 314-315]

⁴¹ We wish to mention briefly an additional property of Ross’s facts which might turn out to be important for future research. All cases of binding by a coordinate of a context that were analyzed so far displayed no locality conditions whatsoever, with the exception of Control. And this was a shame, for otherwise we could have had syntactic and not just semantic and morphological evidence for the existence of embedded contexts. Ross’s facts, on the other hand, do appear to have some locality restrictions. Consider the following examples (p. 232):

- (i) a. Tad knew that it would be a story about himself.
- b. Mike will not believe that this is a photograph of himself.
- c. I promised Omar that it would be a poem about himself. [Ross’s (33)]

- (ii) a. * Tad knew that Sheila had claimed that it would be a story about himself.
- b. * Mike will not believe that Jane found out that this is a photograph of himself.
- c. * I promised Omar to tell Betty that it would be a poem about himself. [Ross's (35)]

Ross first suggests that 'the NP to which the reflexive pronoun bears an anaphoric relationship must belong to the first sentence above the one containing the picture-noun construction'. However he adds in a footnote that this description is in fact incorrect, as shown by the following:

- (iii) Tad concedes that it is probable that it was not known that it would be a story about himself

'What differentiates this sentence from the ungrammatical ones' in [(38)], he suggests, 'is the fact that the sentences which separate the NP 'Tad' and its anaphoric reflexive pronoun here do not contain any occurrences of other human NP' (note 23 p. 264). There is a particularly natural way to state this observation within our framework: reflexivization of a pronoun by a coordinate of a context is subject to intervention effects. Consider the crucial cases:

- (iv) a. Tad knew that $\lambda <x_j, t, w>$ it would be a story about himself_j.
- b. * Tad knew that $\lambda <x_j, t, w>$ Sheila had claimed that $\lambda <x', t', w'>$ it would be a story about himself_j.
- c. Tad concedes that $\lambda <x_j, t, w>$ it is probable that [$\lambda <t', w'>$] it was not known that $\lambda <t'', w''>$ it would be a story about himself_j.

We have made the potentially controversial assumption that attitude verbs in the passive do not contain an author coordinate. Alternatively we could postulate that they do have one, but that it inherits no phi-features for lack of an antecedent. Be that as it may, it would seem that the contrast between a, b and c could be accounted for by an intervention effect of the intermediate author coordinate in b between 'himself' and the highest embedded context.

Surprisingly, Ross's paradigm was for once incomplete, for he did not provide 1st person cases of the intervention effect. Although he did provide a grammatical example, he did not try to add a level of embedding to determine whether, as in the 3rd person case, this led to ungrammaticality. This seems to be indeed the case:

- (v) This is a picture of / story about / description of / joke about myself. [Ross's (36)]

Here is the rest of the paradigm:

- (vi) a. *? Sheila had claimed that it would be a story about myself.
- a'. Ok Sheila had claimed that it would be a story about herself
- b. *? Jane found out that this is photograph of myself.
- b'. Ok Jane found out that this is a photograph of herself.
- c. *? Omar told Betty that it would be a poem about myself.
- c'. <T> Omar told Betty that it would be a poem about himself / herself
- (vii) a. *? Sheila had claimed that it would be a story about myself.
- b. Ok Sheila had made it so that it ended up being a story about myself.
- (viii) Ok It is probable that it was not known that it would be a story about myself.
- (ix) a. ? It was claimed that it would be a story about myself.
- b.?(?) It was discovered that it would be a poem about myself.
- c. ?? It was said that it would be a poem about myself.
- c'. ?? Betty was told that it would be a poem about myself.
- c''. *? Omar said that it would be a poem about myself.

⁴² Here was Kaplan's argument *against* Monsters:

"Are there such operators as 'In some contexts it is true that', which when prefixed to a sentence yields a truth if and only if in some context the contained *sentence* (not the content expressed by it) expresses a content that is true in the circumstances of that context? Let us try it:

(9) In some contexts it is true that I am not tired now.

For (9) to be true in the present context it suffices that some agent of some context not be tired at the time of that context. (9), so interpreted, has nothing to do with me or the present moment. But this violates Principle 2! [NB. Principle 2 states that 'Indexicals, pure and demonstrative alike, are directly referential'. P.S.]. Principle 2 can also be expressed in more theory laden way by saying that indexicals always take primary scope. If this is true - and it is - then no operator can control the character of the indexicals within its scope, because they will simply leap out of its scope to the front of the operator. I am not saying we could not construct a language with such operators, just that English is not one. And such operators *could not be added to it*.

There is a way to control an indexical, to keep it from taking primary scope, and even to refer it to another context (this amounts to changing its character). Use quotation marks. If we *mention* the indexical rather than *use* it, we can, of course, operate directly on it. (...). Operators like 'In some contexts it is true that', which attempt to meddle with character, I call *monsters*. I claim that none can be expressed in English (without sneaking in a quotation device)." [Kaplan, *Demonstratives*, p. 510]

From our perspective, the reason (9) does not shift the context of the embedded indexical is twofold: (i) 'I' is not the sort of indexical that can ever depend on an embedded context (in our terms, it is a 'matrix' indexical); (ii) It is not entirely clear how one should analyze the operator in (9) ('in some contexts it is true that'), but it's at least plausible that it is no attitude operator at all - so that there is no particular reason to expect it to quantify over contexts. If we replace 'I' with an all-purpose indexical, for instance 'in two days', and if we use an attitude verb instead of the operator in (9), we do end up with a sentence in which the context of an indexical can be shifted, even without quotation marks:

(i) John has told me repeatedly over the years that he would give me my money back in two days.

"Are there such operators as 'In some contexts it is true that', which when prefixed to a sentence yields a truth if and only if in some context the contained *sentence* (not the content expressed by it) expresses a content that is true in the circumstances of that context? Let us try it:

(9) In some contexts it is true that I am not tired now.

For (9) to be true in the present context it suffices that some agent of some context not be tired at the time of that context. (9), so interpreted, has nothing to do with me or the present moment. But this violates Principle 2! [NB. Principle 2 states that 'Indexicals, pure and demonstrative alike, are directly referential'. P.S.]. Principle 2 can also be expressed in more theory laden way by saying that indexicals always take primary scope. If this is true - and it is - then no operator can control the character of the indexicals within its scope, because they will simply leap out of its scope to the front of the operator. I am not saying we could not construct a language with such operators, just that English is not one. And such operators *could not be added to it*.

There is a way to control an indexical, to keep it from taking primary scope, and even to refer it to another context (this amounts to changing its character). Use quotation marks. If we *mention* the indexical rather than *use* it, we can, of course, operate directly on it. (...). Operators like 'In some contexts it is true that', which attempt to meddle with character, I call *monsters*. I claim that none can be expressed in English (without sneaking in a quotation device)." [Kaplan, *Demonstratives*, p. 510]

From our perspective, the reason (9) does not shift the context of the embedded indexical is twofold: (i) 'I' is not the sort of indexical that can ever depend on an embedded context (in our terms, it is a 'matrix' indexical); (ii) It is not entirely clear how one should analyze the operator in (9) ('in some contexts it is true that'), but it's at least plausible that it is no attitude operator at all - so that there is no particular

reason to expect it to quantify over contexts. If we replace 'I' with an all-purpose indexical, for instance 'in two days', and if we use an attitude verb instead of the operator in (9), we do end up with a sentence in which the context of an indexical can be shifted, even without quotation marks:

(i) John has told me repeatedly over the years that he would give me my money back in two days.

⁴³ Kuno's account in his 1972 paper was based on two assumptions:

A. The grammar has a rule converting a 1st or 2nd person pronoun into a 3rd pronoun - but no rule would ever convert 'I' or 'You' to 'John'.

B. Direct discourse must be preserved in indirect discourse.

Since the claim that was made by John was of the form 'I am the best boxer in the world' rather than 'John is the best boxer in the world', it follows on Kuno's account that c. in the foregoing examples should be deviant.

The problem with this account is that it is clearly *not* the case that the words of a direct discourse have to be preserved in reported speech - if this were the case, nothing would ever have a De Re interpretation! Furthermore, assumption A. is rather unmotivated as it stands - it simply restates the generalization, without relating it to any independently motivated mechanism.

Kuno's 1972 proposal is reproduced below:

"The direct discourse analysis proposed here claims that all these sentences are ungrammatical for the same reason; namely, in the deep structure, all these occurrences of *John_i* in the embedded clause are actually represented as I, and therefore they should not have received a chance to be realized as full-fledged noun phrases. Furthermore, (17a) [= ?That *John_i* was secretly in love with Mary worried him_i], (18a) [= ?That *John_i* was always unhappy worried him_i] and (19a) [= ?That *John_i* felt hungry all the time worried him_i] are better than (28a) [= ?*The idea that *John_i* was sick worried him_i] because the internal feelings represented by the sentential subjects of these sentences could be forced to assume the status of being abstract facts, while in the latter, *the idea* must presumably be followed by a direct feeling representation in the deep structure."(p. 168).

⁴⁴ 'Self-ascription' is taken by Lewis to be a primitive; it is a relation between an individual and a property (if Lewis's terminology seems obscure, replace 'self-ascribes' with 'ascribes to himself').

⁴⁵ Chierchia 1987 cites another case of object control ('persuade'), which he contrasts with 'force', which is not an attitude operator. Chierchia puts the point somewhat differently: he claims that in this case the relation involving the infinitive 'entail[s] and [is] also entailed by the relevant de re propositional construction', so that 'de se and de re readings will collapse into one' (Chierchia 1987 p. 17).

⁴⁶... except that, as D. Pesetsky notes, this doesn't make much sense: in proper Latin 'de te' should be the 2nd person counterpart of 'de me', not 'de se'. Still, for the illiterati among us, the term is suggestive, so I will keep it.

⁴⁷For instance, the contrasts in (15 i) seem to become weak (or to disappear) when a 2nd person pronoun is used instead of 'Peter (Smith)' or 'your friend' (I. Heim, p.c.):

(15') (i) Situation 1: In 1867, Anna Smith left a note for the eldest of her great-grandchildren, in case she was to have any. The note read: 'Behave!'. You are this person, and finally get the note.

- a. The note says to you PRO to behave
- b. The note says to you that you should behave
- c. The note says that you should behave.

I do not know why this should be so. One could argue from these examples that the contrasts in (15 i) and (16 i) are the result of a bias (for instance the presence of a full noun phrase in the embedded clause). But it is unclear why the *same* bias should not also yield similar contrasts in (15 ii) and (16 ii).

⁴⁸ There is another possible worry. In (15), (i b) and (ii b) involve a weak Condition C violation. The violation is relatively mild because the c-commanding expression is an R-expression ('The note said to him_i that [Peter Smith]_i should behave' is worse than b.) In any event, the contrast between (i b) and (ii b) shows that something else is going on. But if one wishes to eliminate the (weak) violation, one can use the following examples:

(15'') (i) Situation 1: Same as in (15 i)

- a. The request PRO to behave was made to Peter Smith / him in his great-grandmother's letter.
- c. #The request that Peter Smith should behave was made to Peter Smith / him in his great-grandmother's letter.
- d. The request that he should behave was made to Peter Smith / him in his great-grandmother's letter

(ii) Situation 2: Same as in (15 ii)

- a. The request PRO to behave was made to Peter Smith / him in his grandmother's letter.
- c. The request that Peter Smith should behave was made to Peter Smith / him in his grandmother's letter.
- d. The request that that he should behave was made to Peter Smith / him in his great-grandmother's letter

No Binding-theoretic violation occurs here, and the crucial contrasts still hold. c. shows that no De Re reading is available, although a De Se reading is. And 'he' can be used in b., which suggests that it does have a De Se reading.

⁴⁹ If a De Se reading systematically entailed a De Re reading, it would be very hard to show that 'he' does have a distinct De Se reading. Part of the problem is that every situation satisfying the purported De Se reading would also be compatible with the De Re reading, so that we couldn't construct a direct argument that the De Se reading exists. There are normally ways around this, but they happen to be particularly difficult in the present situation.

A standard trick is to reverse the entailment relations between the two readings by placing a given sentence P in the antecedent of a conditional, according to the following logic:

- (i) a. The problem is that P has a weak reading W and maybe a strong reading S. $S \Rightarrow W$, so every situation that satisfies S also satisfies W.
- b. Consider P':= 'If P, then Kaplan will do something about it', i.e. P':= $[P \Rightarrow K]$. P' has a reading $W \Rightarrow K$ and maybe a reading $S \Rightarrow K$.
- c. But since $S \Rightarrow W$, $[W \Rightarrow K] \Rightarrow [S \Rightarrow K]$ but in general not $[S \Rightarrow K] \Rightarrow [W \Rightarrow K]$. So if we can find a situation that satisfies $W \Rightarrow K$ but not $S \Rightarrow K$ we will have shown that P has a Strong reading. We could now try to apply this strategy to our problem in the following way:

(ii) a. 'If Kaplan thinks that his pants are on fire, he will do something about it!'

b. Prediction:

-If the sentence only has a De Re reading, the claim is necessarily falsified by the mirror situation: Kaplan believes that Kaplan's pants are on fire, but he doesn't do anything about it.

-If the sentence also has a De Se reading, there is one construal of a. on which it is not falsified - if what was meant was the De Se reading, Kaplan's De Re belief about Kaplan is irrelevant

Here is a variation on the same theme:

(iii) a. Kaplan is in front of a mirror, and watches the mirror intensely. At t , he sees in the mirror someone whose pants are on fire - and doesn't realize that that person is Kaplan himself. At $t+1$, he realizes - by direct experience - that his *own* pants are on fire.

b. Question: What is the first time Kaplan thought his pants are on fire?

c. Prediction: -If the sentence has just one reading, there should be just one possible answer: 't'
 -If the sentence has two readings, subjects should say something like: it depends what you meant - on one reading at t , on the other reading at $t+1$.

There is a difficulty, however. It has sometimes been denied in the literature that there is *one* De Re reading of a sentence, because -so the argument goes- the acquaintance relation used to get a De Re reading is *not* existentially quantified over (as in the Kaplan/Lewis semantics), but rather is given by the context. If this is correct, there isn't one De Re reading, but rather a series of them:

(iv) a. Ralph believes that Ortcutt is a spy

b. Ralph believes $\lambda\langle x, w \rangle [\exists y \alpha(x, y, w)]$ is a spy in w , where α is a SALIENT acquaintance relation between Ralph and Ortcutt

(v) (iva) is true if $\alpha = \lambda y \lambda x \lambda w y = \text{the man in the brown hat seen by } x \text{ in } w$
 (iva) is false if $\alpha = \lambda y \lambda x \lambda w y = \text{the man by } x \text{ at the beach in } w$

The difficulty is that there is now a series of De Re readings, and the De Se reading is just one of them, and is not formally distinguished:

(vi) a. Kaplan thinks that his pants are on fire

b. Kaplan believes $\lambda\langle x, w \rangle [\exists y \alpha(x, y, w)]$'s pants are on fire in w , where α is a SALIENT acquaintance relation between Ralph and Ortcutt

(vii) De Se reading: $\alpha = \lambda y \lambda x \lambda w (y = x \text{ in } w)$

De Re, non De Se: $\alpha = \lambda y \lambda x \lambda w (y = \text{the man seen by } x \text{ in the mirror in } w)$

etc.

⁵⁰ One could reply that this is because semantics is interested in... semantic representations. And that within a modular theory of the grammar, morphology is computed in a different component. But of course the fact that interpretation and morphology belong to different modules does not mean that the theory shouldn't be constrained by both types of information - quite the opposite.

⁵¹ To put it more formally:

1. An item I can be inserted in a node N only if the features of I [$=F(I)$] are a subset of the features present in N [$=F(N)$], i.e.

I is inserted in N only if $F(I) \subseteq F(N)$

2. Item I can be inserted only if there is no item I' containing a proper superset of its features which also satisfies condition 1. (in other words, the item that gets inserted must be the most specific one compatible with the node):

I is inserted in N only if: $\neg \exists I' F(I) \subset F(I') \subseteq F(N)$

3. In case conditions 1. and 2. do not uniquely determine which item is inserted, extrinsic principles of priority among features must be used to decide how insertion proceeds ['feature hierarchies' are

supposed to tell the system which features it is most desirable to express].

⁵² As Kai von Fintel (p.c.) observes, there is a minimal contrast between 'only I' and 'nobody but me/I', which are semantically equivalent but display different agreement patterns (stars are given for a bound variable reading):

- (i) a. Only I do my / *his homework
- b. Nobody but me/I does his / their / *my homework.

⁵³ This section can be skipped by any reader who is not interested in scholastic matters.

⁵⁴ ... as are some the judgments we rely on in Chapter 4. And, just as Kratzer's, these can and should be challenged.

⁵⁵ If I understand it correctly, Kratzer's system makes an interesting prediction. In the tense domain, a Zero tense is always bound by a local λ -abstractor, with the result that it is always read De Se. Presumably the same principle holds in the pronominal domain:

- (i) Principle (?)

A zero element (tense or pronoun) under an attitude operator is always read De Se.

Kratzer's original point was that bound variable readings of 'I' result from a configuration in which a zero pronoun appears in the syntax:

- (ii) a. Only I got a question that I understood
- b. [Only I]₁ got a question that \emptyset ₁ understood [Kratzer's (4')]

So of course the same fact should hold of bound variable readings when 'I' appears under an attitude operator:

- (iii) a. Only I thought that I didn't sound too aggressive [variation on Reinhart 1991]
- b. [Only I]₁ thought that \emptyset ₁ didn't sound too aggressive

So the prediction appears to be that on a bound variable reading the embedded 'I' in (iii) could only be read De Se. But this is incorrect:

(iv) **Situation:** Several people played a tape of their own voice, among many others. The test is to determine whether, when they hear their voice without recognizing it, they think that it sounds too aggressive. As it turns out, I am the only person who believes his voice to sound too aggressive.

<> Only I thought that my voice was too aggressive.
J'ai été le seul à penser que ma voix était trop agressive.

Clearly the intended reading is a bound variable one. But given the situation the reading cannot be De Se. The correct representation seems to be the following:

- (v) [Only I] λx x thinks that $\lambda \langle x', t', w' \rangle$ x didn't sound too agressive at t' in w'

⁵⁶ A presuppositional treatment of gender agreement is offered in Cooper 1983, who in addition has a discussion of natural vs. grammatical gender (p. 235).

⁵⁷There has been much discussion on the interpretation of ϕ -features in cases of VP-ellipsis. While it is often assumed that the issue of bound variable readings arises in the same way for VP-ellipsis and for only-examples, this is not correct.

1. In VP-ellipsis, there appears to be a lot of variation concerning the status of bound variable readings that involve gender mismatch between the antecedent and the elided element. But this does not seem to be the case with example like (8a): as far as I can tell the bound variable reading is perfect, even when it is clear that the variable ranges over male *and* female individuals. By contrast, the facts are rather murky in VP-ellipsis. The point had been noted by Sag 1976 in a footnote (fn. 15, p. 181):

(i) Sag on 'John scratches his arm and Mary did too'

"Not all speakers find [(i)] ambiguous. For some of the those speakers, it is the discrepancy of gender that blocks the 'sloppy' reading. Others object to similar examples involving discrepancy of person and/or number. Virtually all speakers find [(ii)] ambiguous, however.

(ii) John scratched his arm, and Bill did too."

The same point is made by Kitagawa 1991, with a detailed investigation of idiolectal variations in speakers' judgments.

There the data are complex, and in addition there appear to be differences across speakers. The situation appears to be different with 'only he' examples, where the reading in (8a) [i.e. a bound variable reading in which the variable ranges over male *and* female individuals] appears to be very clearly available.

2. There is in fact another case in which only-sentences and ellipsis display different properties. In French the 3rd person reflexive clitic 'se' allows only for bound variable readings when an IP is elided. But in some 'only' environments, both for a strict and for a sloppy reading are available (this is clearer in c. than in b.:

(iii) a. Pierre se trouve intelligent, et Jean aussi
Pierre SE finds intelligent, and Jean too

'Pierre finds himself intelligent, and Jean does too'
Ok bound variable reading: Jean finds Jean intelligent
* strict reading: Jean finds Pierre intelligent

b. Seul Jean se trouve intelligent
Only Jean SE finds intelligent

'Only Jean finds himself intelligent'

Ok [Only Jean] λx x finds x intelligent
(?) [Only Jean] λx x finds Jean intelligent

c. Jean est le seul à se trouver intelligent
Jean is the only-one to SE find intelligent

'Jean is the only one to find himself intelligent'

Ok [Only Jean] λx x finds x intelligent
Ok [Only Jean] λx x finds Jean intelligent

⁵⁸ This will have to be refined. Certainly a 3rd person feature does not contribute a presupposition that the value of the element on which it appears does not denote the speaker, for otherwise the following would be a contradiction:

(i) [Uttered by Kaplan, point at his own picture] His pants are on fire!

⁵⁹As was mentioned in a preceding footnote, D. Petros (p. c.) has observed that all-purpose indexicals can occur in an embedded clause *only* under the verb 'alu', which means roughly 'say', but has a considerably broader use than its English counterpart. Thus the Amharic version of 'tell' appears to behave like the English verb. Is there any way we can capture the difference between Amharic 'say' and Amharic 'tell'?

If we remain faithful to the system developed so far, there is one way to capture the distinction. Suppose that only certain verbs (in this case, only 'alu') allow coordinates of an embedded context to bear the diacritics a, h, t, w. This would yield two sorts of derivations, depending on the matrix verb:

- (i) a. C ... SAY ... $\lambda < x^a, y^b, t^t, w^w > x^a$...
- b. C ... TELL ... $\lambda < x, y, t, w > x$...

(ia) is what has been described so far. (ib) forces a 3rd person pronoun (unspecified for 'a' or 'A') to be inserted, with the result that Amharic 'tell' will yield English-style indirect discourse, so that (a) no indexical pronoun can have a shifted reading, and (b) a third person pronoun can be inserted.

The problem is that once this distinction is posited between Amharic 'say' and Amharic 'tell', it is not clear that there remains much motivation for making use in the pronominal domain of the distinction between matrix and all-purpose indexicals. More specifically, the system we are now using is so powerful that it gives us two ways to account for the English facts:

I. English 'I' is a matrix indexical, and differs in this respect from its Amharic counterpart, which can be evaluated either with respect to a matrix or an embedded context (this is the line we have been following in this chapter).

II. But it could also be that English 'I' is exactly similar to Amharic 'I', and that the only difference between English and Amharic lies in the fact that the latter has an attitude verb that inserts the diacritics a, h, t, w on the coordinates of an embedded context, while English has no such verb.

Note however that the facts of Aghem and Engenni suggest that distinctions between Attitude verbs will not suffice to account for all the facts, since there is in addition a minimal difference between different indexical pronouns in a single environment (the 2nd person pronoun can be shifted, but the 1st person pronoun cannot). So it looks like both types of lexical distinctions might be needed, which leads to a particularly powerful system.

⁶⁰Some examples that Kratzer lumps together under the heading 'non-source perspective' appear to indicate that (inclusive) 'man' is underspecified with respect to the author vs. hearer coordinate, at least in embedded contexts:

(i) Der Psychiater machte jedem Paar klar, dass man sich erst nach vielen Jahren so richtig gut
the psychiatrist made each (dat) couple clear that 'man' refl. only after many years so really well

verstehen würde [Kratzer's example (5) on p. 13]
understand would

The direct discourse pronoun that 'man' is reporting in this case is 'you-pl', not 'we'. Thus it looks like 'man' can be semantically dependent on the *hearer* coordinate of an embedded context.

⁶¹ 'more' in the sense of having features that are a proper superset of those of the other item.

⁶²Interestingly, it is possible to show that the gender features remain uninterpreted on a De Se reading. Consider the following case:

(i) **Situation:** Pierre (who is deluded) believes that he (himself) is a woman [he believes the first-person thought: 'I am a woman']. He is also convinced that every woman is jealous of him.

- a. Pierre croit qu'il est de sexe féminin, et que toutes les femmes sont jalouses de lui
- b. ?? Pierre croit qu'il est de sexe féminin, et que toutes les femmes sont jalouses d'elle

If the masculine features in a. were interpreted, they would presumably restrict the range of the variable 'lui' to male individuals; and this would presumably yield a contradiction, since for all he knows Pierre is a woman. On the other hand given the system of agreement we use, these facts are unsurprising since the gender features on 'lui' are the result of agreement, and thus remain uninterpreted:

(ii) $\langle X^A, Y^B, T^C, W^D \rangle \lambda \langle X^A, Y^B, T^C, W^D \rangle$ Pierre^B believes at T^C in W^D that $\lambda \langle x^A, t^C, w^D \rangle$ every woman is jealous of x^A /him^B/

⁶³This is the characterization Clements gives of Ewe 'yè'; the passage we omitted reads: <to designate the individual> '(other than the speaker)' <whose speech...>. In Gokana, on the other hand, logophoric marking may be used even when it is the speaker's thoughts which are reported; even in this case, however, logophoric marking on a 1st person antecedent appears to be dispreferred. I have no explanation for this.

⁶⁴There is a remarkable similarity between Clements's definition and Castañeda's characterization of 'he*' in Castañeda 1968:

"In the sequel we shall be concerned almost exclusively with third-person statements that ascribe self-knowledge to others, like

(3) The Editor of *Soul* knows that he (himself) is a millionaire.
and

(4) The Editor of *Soul* knows that Mary knows that her niece knows that he (himself) is a millionaire.

In these cases the attribution of self-knowledge is made by means of the third-person pronoun 'he (himself)' to be abbreviated 'he*', which has here the following characteristics:

- (i) it does not express an indexical reference made by the speaker;
- (ii) it appears in *oratio obliqua*;
- (iii) it has an antecedent, namely 'the Editor of *Soul*', to which it refers back;
- (iv) its antecedent is outside the *oratio obliqua* containing 'he*';
- (v) 'he*' is used to attribute, so to speak, implicit indexical reference to the Editor of *Soul*; that is, if the Editor were to assert what, according to (3) and (4), he knows, he would use the indicator 'I' where we, uttering (3) and (4), have used 'he*': he would assert, respectively,

(3a) I am a millionaire
and

(4a) Mary knows that her niece knows that I am a millionaire." [Castañeda 1968 pp. 440-441]

⁶⁵We abstract away from the difference between Ewe and Gokana: while Gokana logophoric markers can to some extent be used even when the matrix subject is in the first person, this is not possible in Ewe.

⁶⁶Here are her lexical entries (p. 5):

- (i) a. [[MAN]]^C, W = the speaker in (context) c
- b. [[IN]]^C, W (a) = the group of a in (world) w

⁶⁷Thanks to Idan Landau for providing some crucial generalizations about partial control that gave the impetus for this discussion.

⁶⁸Hyman & Comrie 1981 give examples that make the same point:

(i) a. *lébàrèè* *kɔ* *m̀m̀* *gbɪ* *gè* *de-è* *a* *gɪá* [H & K (26b)]
Lebare *said* *I* *wanted* *to* *eat-LOG* *his* *yams*

‘Lebare_i said that I wanted to eat his_i yams’

b. *lébàrèè* *kɔ* *m̀m̀* *gbɪ-è* *gè* *de-è* *a* *gɪá* [H & K (26b)]
Lebare *said* *I* *wanted-LOG* *to* *eat-LOG* *his* *yams*

‘Lebare_i said that I wanted to eat his_i yams’

One complication (reflected in the optionality between a. and b.) is that logophoric marking may appear only on the verb closest to the (De Se) pronoun, as in a., or both on the closes verb and on the next higher verb. But what seems clear is that logophoric marking can appear even when the antecedent is two clauses up. There do not appear to be locality constraints on logophoric marking.

⁶⁹At first blush a plausible set of lexical entries would be:

(i) Mapun pronoun (2nd version)

A	<->	[3, -a, -h]
B	<->	[3, a]
C	<->	[3]

C is a default form, A is the non-logophoric form, while B is the author-denoting logophoric form. The point is that in order to get the correct distribution, we need a feature $\pm h$ [these entries cannot be entirely correct, for they predict that A and C should never be in free variation, since the feature of C are a proper subset of those of A.

⁷⁰ Frajzingier also mentions another Chadic language, Pero, which apparently has only one logophoric pronoun, which is a hearer-denoting one. As we will see, however, the description that Frajzingier would rather suggest that this form is an all-purpose ‘you’, like the forms observed in Aghem and Engenni. The reason for this is that, contrary to strict logophoric pronouns, the form can also appear when no attitude verb is present or understood:

(i) a. ‘*di-* *ko* *kan* *ka* *daklani-* *a*
settle *COMPL* *ASSOC* *2m* *bad* *INTERR* [Frajzingier’s (22a)]
‘Is it bad that he settled with you?’

b. ‘*di-* *ko* *kan* *peemu* *daklani-* *a* [Frajzingier’s (22b)]
settle *COMPL* *ASSOC* *LOG-2m* *bad* *INTERR*
‘Is it bad that he settled with you?’

(ii) a. *ca* *mu* *kayu* *peemu*
said *OPT* *drive away* *LOG-2m*
‘[He₁] said that he₂ should be driven away’ [Frajzingier’s (23a)]

i.e. He said that his interlocutor should be driven away

b. ca peemu ta kayu laa mu mijiba
 said LOG-2m FUT drive man DEM stranger [Frajzingier's (23b)]
 '[He₁] said that he₂ is going to drive the stranger away'
 i.e. He said that his interlocutor is going to drive the stranger away

Cf. Frajzingier's observation:

'Note the difficulty involved in translation between two systems that do not encode the same semantic notions. While 'peemu' in Pero refers specifically to the addressee of the reported conversation, the pronoun 'he' in English may refer to any third person. Contrary to what is implied by the English translation it is not any disjoint reference that is encoded in Pero but rather distinction between a speaker and an addressee of the reported conversation.'

⁷¹Our system can apparently derive a generalization that Banfield had to stipulate. As she observed (her (48b) p. 93) there are specific constraints on the use of a 1st person pronoun in Free Indirect Discourse:

(i) "Priority of SPEAKER. If there is an 'I', 'I' is coreferential with the SELF. In the absence of an 'I', a third person pronoun may be interpreted as SELF."

In our terms, this means that in case a 1st person pronoun appears in Free Indirect Discourse, it must be the case the the author of the matrix context bears the diacritic 'I'

-i
 In other words, the speaker of the actual speech act and the author of the matrix context must be identical. This, however, is not a separate principle, but follows from the architecture of the system outlined so far.

Consider the following contrast [modified from Banfield 1982 (p. 100)]:

(ii) **Situation:** I / Bill asked Mary: 'What are you thinking about me now?'
 a. What was she thinking about me now? (I asked Mary.)
 b. #What was she thinking about me now? (Bill asked Mary.)

a. has a simple analysis:

(iii) $\langle X^I_i, \text{Mary}^I_k, T^{\text{Ind}}, W^{\text{I}} \rangle \lambda \langle X^I, Y^I, T^{\text{Ind}}, W^{\text{I}} \rangle$ What be Y thinking about X^I /me_I / ...?

Although the hearer of the matrix context does not bear the 'I' diacritic (this is because the hearer of the matrix context is *not* the hearer of the actual speech act), the author coordinate of the matrix context does bear the diacritic 'I', since in this example it is supposed to refer to the actual speaker.

Thus the object of 'think about', which is bound by X^I , inherits the 'I' diacritic, and is thus spelled-out as a 1st person pronoun.

Now consider the ungrammatical case. Since this is a case of Free Indirect Discourse, and it is understood that Bill

is the speaker, the representation must be:

(iv) $\langle \text{Bill}^I, \text{Mary}^I, T^{\text{Ind}}, W^{\text{I}} \rangle \lambda \langle X^I, Y^I, T^{\text{Ind}}, W^{\text{I}} \rangle$ What be Y thinking about X^I /me_I / ...?

Since Bill is not the speaker of the actual speech act, the constant 'Bill' in the matrix context cannot bear the diacritic 'I'; this, in turn, entails that 'me' cannot be coindexed with 'Bill'. Hence 'me' must

refer to the actual speaker, rather than to Bill. But even on the assumption that Bill has any desire to refer to *me*, the word he would use would be 'him' rather than 'me'. But as we observed before, in Free Indirect Discourse every element which is not bound by a coordinate of a context must be quoted; hence since 'me' can neither be quoted nor bound by a coordinate of the context, the sentence is deviant.

²²It is not clear whether we have been successful in actually *deriving* the properties of Free Indirect Discourse. The problem is that our analysis hinges on a distinction between capitalized and non-capitalized contexts, for which there is little independent evidence. One major reason the property 'being a capitalized context' could *not* be reduced to the appearance of the features $\lambda, \mu, \tau, \omega$ on the coordinates of the context was precisely the existence of Free Indirect Discourse, where 'I', 'you' etc. (=elements that spell-out the features) on the one hand, and 'tomorrow' on the other, display different behaviors. Had Free Indirect Discourse not existed, we could have tried to do away with the distinction - along the following lines:

The distinction between 'in two days' and 'tomorrow' would have had to be defined in terms of contexts whose coordinates bear $\lambda, \mu, \tau, \omega$ vs. those that don't. Things would have been a little tricky, because embedded contexts must be allowed to bear these diacritics too, in case they inherit them through agreement:

- (i) a. I swear to you that I do not hate you
 b. $\langle X^{\lambda}, Y^{\mu}, T^{\tau}, W^{\omega} \rangle \lambda \langle X^{\lambda}, Y^{\mu}, T^{\tau}, W^{\omega} \rangle X^{\lambda} / I_{\lambda} /$ swear to $Y^{\mu} / \text{you}_{\mu} /$ at T^{τ} in W^{ω} that $\lambda \langle X^{\lambda}, Y^{\mu}, T^{\tau}, W^{\omega} \rangle X^{\lambda} / I_{\lambda} /$ do not hate $Y^{\mu} / \text{you}_{\mu} /$ at T^{τ} in W^{ω}

Still, the reduction could have been achieved; the lexical entry for 'tomorrow' would have specified that it can only take as argument a context whose coordinates bear the features $\lambda, \mu, \tau, \omega$ and no features $\alpha, \beta, \gamma, \delta$. While a little cumbersome, such an entry can in principle be defined.

So at this point the distinction between capitalized and non-capitalized contexts appears to be a stipulation, needed especially to account for Free Indirect Discourse. But there is a way to have our cake and eat it too - we can in fact both (i) simplify the system, by suppressing the distinction between capitalized and non-capitalized contexts, while at the same time (ii) retaining the prediction that 'tomorrow' and 'I' should part company in Free Indirect Discourse. Here is how.

Suppose 'tomorrow' is defined on the context constant $\langle X^{\lambda}, Y^{\mu}, T^{\tau}, W^{\omega} \rangle$ rather than on the context variable $\langle X^{\lambda}, Y^{\mu}, T^{\tau}, W^{\omega} \rangle$ [the intuition being that 'tomorrow' is a demonstrative rather than an indexical]. Assume, furthermore, that there is no distinction between capitalized and non-capitalized contexts. Free Indirect Discourse cases are now analyzed as follows:

- (ii) a. Oui, vraiment, il l'aimait, et demain....
Yes, really, he loved her, and tomorrow...
 b. $\langle J^{\beta}, M^{\gamma}, 1960^{\delta}, W^{\omega} \rangle \lambda \langle X^{\lambda}, Y^{\mu}, T^{\tau}, W^{\omega} \rangle$ Yes, really, X^{λ} love Y^{μ} , and tomorrow ($\langle J^{\beta}, M^{\gamma}, 1960^{\delta}, W^{\omega} \rangle$)...

'tomorrow' can still be shifted in Free Indirect Discourse (since $\langle J^{\beta}, M^{\gamma}, 1960^{\delta}, W^{\omega} \rangle$ is represented just as any other context constant is), but it cannot be in standard indirect discourse, since there no context constant is available to begin with.

There is one problem with the purported simplification, however - it is not clear how it would handle the interpretation of quotations of the following sort [the problem was already mentioned in fn. XX]:

(iii) Everybody said to someone at some point or other: 'I hate you today'

Here the context of the quoted sentence appears to be bound:

(iv) [Everybody] λx [someone] λy [some point] λt x said to y at t (at W): $\langle x, y, t, W \rangle$ 'I hate you today'

⁷³An enterprise of this nature could appear objectionable if one thought of theories extensionally, i.e. as sets of facts. Under such a conception, two theories are identical just in case they make exactly the same predictions. Any attempt at *deriving* the principles of an existing theory would be utterly futile, since all this would yield would be the *same* theory, i.e. (by definition) one that makes that same predictions. But of course nobody has such a conception of scientific inquiry. If all that counted was to get the facts right, one would simply *list* them. Academic life would be boring, but easy.

⁷⁴In more complex cases, a 1st or a 2nd person pronoun can spell-out a variable which is bound by an element which is *not* a coordinate of a context. In these cases the variable inherits 1st or 2nd person agreement.

⁷⁵At first glance von Stechow seems to imply that tense in attitude environments can not be read De Re. Thus he suggests on p. 372 (3-11) that there can be 'no free tense in strong intensional contexts [=in attitude environments -PS]'. But in fact he does allow for De Re construals of tense under an attitude operator when he treats Double Access readings (pp. 375-376).

⁷⁶The argument typically used to show that Tense can be read De Se has the following logic:

(a) John might be wrong about the time, and thus believe that 3:47 pm: 'It is now 4:00 pm'.

(b) We can report this by saying: 'John believed (at 3:47 pm) that it was 4:00 pm'

(c) If attitude operators only allowed for De Re readings with respect to time, John's belief would have to be that he lives in a world in which 3:47 pm = 4:00 pm

(d) But there are no worlds in which 3:47 pm = 4:00 pm. The analysis wrongly implies that if John is wrong about the time, he must believe the empty proposition, and thus be irrational.

Here are some version of the argument:

(i) Ogihara 1996 (pp. 114-115)

"Examples like the following are discussed by Perry (1977) and by Lewis (1979):

a. John believes that it is 4 pm

(...) If the object of belief is a set of worlds, [a] translates as [b]:

b. believe' (5 pm, John, λw [5 pm = 4 pm])

(ii) Kratzer 1998 (p. 11)

"The temporal De Se can best be illustrated with sentences of the following kind (see e.g. v. Stechow 1982):

a. John thinks that it is 10 o'clock

If the tense in [a] was indexical, and [a] was uttered at 11 o'clock, for example, then [a] would say that John thinks that 11 o'clock is 10 o'clock. That's not the prominent reading of that sentence, however. On its most natural reading, [a] says that John 'temporally self-locates himself' at 10 o'clock'..."

This is the temporal version of an example discussed in Perry 1977 and Lewis 1979: Heimson might believe: 'I am Hume', without thereby believing that he lives in a world in which Heimson = Hume (there are no such worlds). But as noted in Chapter 2, Lewis was interested in the De Se problem as it arises in the philosophy of mind. His point is that the objects of thoughts must be at least as fine-grained as properties. But this does not entail that the object of natural language operators must be at least as fine-grained as properties. Thus Kaplan's analysis in 'Adding 'Says'' was a way to claim both that (a) 'say' can be compatible with a De Se situation, but that (b) it does not have to yield any De Se readings. In fact Kaplan discusses examples of exactly this type (in the pronominal domain):

(iii) '... when you wonder, 'Is that me?', it is correct to report you as having wondered whether you are yourself (...). the idea is that the full analysis of indirect discourse includes mention of the suppressed character of the direct discourse event which the indirect discourse reports...' (p. 554).

Consider again Kaplan's solution [repeated from Chapter 2]:

- (iv) a. Lingens believes that he is in the Stanford library
 b. Lingens believes in w^* that λw Lingens is in the Stanford library in w
 c. $\exists c, \chi$ [c is a context & χ is a character & Lingens is the author of c & Lingens believes a thought with character χ & $\chi(c)=\lambda w$ Lingens is in the Stanford library in w]

If we apply this solution to the Heimson example, we obtain:

- (v) a. Heimson believes that he is Hume
 b. Heimson believes in w^* that λw Heimson is in the Stanford library in w
 c. $\exists c, \chi$ [c is a context & χ is a character & Heimson is the author of c & Heimson believes a thought with character χ & $\chi(c)=\lambda w$ Heimson = Hume in w]

Now this might seem shocking, since there are no worlds in which Heimson = Hume. So Heimson believes a thought whose *content* is empty. But is this a problem? No. Given Kaplan's analysis, we ascribe irrationality to Heimson only in case we claim that he believes a *character* which is empty. But such is not the case here. The character of the thought that Heimson actually believes is:

- (vi) $\chi^* = \lambda c \lambda w$ author(c) = Hume in w

Clearly χ^* is not empty [i.e. there are contexts c and worlds w such that author(c) = Hume in w; by contrast there were no worlds w such that Heimson = Hume in w]. And if c^* is the context of Heimson's thought, it is also clear that:

- (vii) $\chi^*(c^*)$ = $[\lambda c \lambda w$ author(c) = Hume in w](c^*)
 = λw [Heimson = Hume in w]
 = \emptyset

Exactly the same reasoning can be applied to the temporal example. If John believes (at 3:47 pm) that it is 4:00 pm, Kaplan's solution yields the following analysis:

- (viii) a. John believes at 3:47 pm that it is 4:00 pm
- b. John believes at 3:47 pm in w^* that λw 3:47 pm = 4:00 pm in w
- c. $\exists c, \chi$ [c is a context & χ is a character & John is the author of c & 3:47 pm is the time of c & John believes at 3:47 pm a thought with character χ & $\chi(c) = \lambda w$ 3:47 pm = 4:00 pm in w]

John's original thought had the character in (ix), which indeed yields an empty content given his thought situation [(x)]:

- (ix) $\chi^* = \lambda c \lambda w$ time(c) = 4:00 pm in w
- (x) $\chi^*(c^*) = [\lambda c \lambda w$ time(c) = 4:00 pm in w](c^*)
 $= \lambda w$ 3:47 pm = 4:00 pm in w]

⁷⁷Partee 1984 has examples that show that a tense can be a bound variable (her (5), p. 246):

- (i) a. Whenever Mary telephoned, Sam was asleep.
- b. When Mary telephoned, Sam was always asleep.
- c. Whenever Mary wrote a letter, Sam answered it two days later.
- d. Whenever John got a letter, he answered it immediately.

What these examples do not show, however, is that the tense features are uninterpreted. It could be that even in the quantified cases the tense features contribute a presupposition that the moments quantified over (more precisely, the elements of the restrictor) are in the past. Since the constraint is satisfied in (i), there is no argument that the features can remain uninterpreted. Such is not the case in the temporal version of Heim's examples.

⁷⁸In fact it is not clear at all that 'now' is a matrix indexical. It appears to be shifted in number of environments:

- (i) After immigrating to the US in 1941, Peter thought that he was now in complete safety.

Whether 'now' is a matrix or an all-purpose indexical will not affect our point.

⁷⁹German 'man' (whether inclusive or exclusive) is analyzed by Kratzer 1997 as a definite. This is potentially relevant to the present question, since 'man', just as the Russian example in a., can receive an existential reading. [French 'on' also has existential readings]. Kratzer cites the following contrasts as evidence for an analysis based on definiteness (her (1)-(3), p. 6):

- (i) a. *Es war man gekommen
there was man come
 'They / we had come'
- b. Es war wer gekommen
there was somebody come
 'Somebody had come'

c. Es war jemand gekommen
there was somebody come

'Somebody had come'

⁸⁰ In these simple cases our treatment reduces to Heim 1994's presuppositional analysis of past tense (rather, to the first version of her proposal, since the analysis is modified later in her paper). The only difference is that we put the presupposition in the logical form, while she directly encodes it in the interpretive rules. Thus the interpretation of a past tense variable is as follows (we adapt the notation⁸⁰):

(i) $[[t^{\text{Past}}]]_s$ is defined only if $s(t^{\text{Past}}) < t_c$, where t_c is the time of utterance

⁸¹ For reasons that will become clear in a later footnote, we will remain agnostic on the feature specification of the Russian past tense.

⁸² The problem is that within our system standard principles of Competition for Insertion make the wrong prediction in this case [at least if it is assumed that the Russian past tense has the entries /PAST_{Rus}<↓/ and /PAST_{Rus}<↑/]. Consider the unabbreviated notation, where **Past** is replaced with <,↑.

(i) $C^* \lambda C$ P. says at $t^{<,\uparrow} \dots$ that $\lambda < \dots t^{\downarrow,<,\uparrow} \dots >$ M. cries at $t^{\downarrow,<,\uparrow}$

So far we have assumed that Russian had two entries: /PRES_{Rus}↓/ and /PRES_{Rus}↑/. But Russian also has a past tense. Suppose that, like the Present, it may either contain a feature ↓ or a feature ↑. This would give us two additional entries: /PAST_{Rus}<↓/ and /PAST_{Rus}<↑/.

Clearly, either of these is more highly specified than /PRES_{Rus}↓/, and still compatible with the features that appear on the embedded variable: ↓, <,↑. This falsifies our theory: the past tense should systematically be inserted in these cases. [Note that the version of our theory in which underspecification rather than homophony is posited for Russian suffers the same defect. Even if there is a single underspecified entry /PRES_{Rus} t/ (with ↑=[t, +matrix] and ↓=[t, -matrix]), and a single entry /PAST_{Rus} <, t/, the problem will reappear: /PAST_{Rus} <, t/ will be more highly specified than /PRES_{Rus} t/, while still compatible with the features borne by the embedded variable - causing the same problem as before].

I can think of two possible reactions to the problem. One is to take it to falsify the decompositional theory of the Past tense. Reverting to a conservative notion of the past tense allows one to state the same stipulation for tense as was used for person, with empirically adequate results. Another possibility is that the decompositional theory is correct, but that the Russian Past is not specified for either ↓ or ↑, but only for <. The same stipulation as in the Person case could then be used: UG prefers to express ↓ over <, and therefore /PRES_{Rus}↓/ wins over /PAST_{Rus}</ in the insertion procedure. This, however, cannot be correct: when a shifted *past* tense appears in the under an attitude verb, the stipulation would predict that a present tense morpheme should be used, since the features present in the syntax would be: <,↓, and the principle of preference we just defined would favor /PRES_{Rus}↓/ over /PAST_{Rus}</. One could further stipulate that principles of preference are sensitive to whether a feature is or is not interpreted, but at this point this would just amount to an additional stipulation.

⁸³As was already mentioned, the argument that the features were not interpreted was indirect. It hinged on the assumption that the embedded pronoun had the option of being read De Se - and *that* argument was not so easy to make. The most direct evidence that we have was cited in a footnote:

(i) **Situation:** Pierre (who is deluded) believes that he (himself) is a woman [he believes the first-person thought: 'I am a woman']. He is also convinced that every woman is jealous of him.

a. Pierre croit qu'il est de sexe féminin, et que toutes les femmes sont jalouses de lui

b. ?? Pierre croit qu'il est de sexe féminin, et que toutes les femmes sont jalouses d'elle

If the masculine features in a. were interpreted, they would presumably restrict the range of the variable 'lui' to male individuals; and this would presumably yield a contradiction, since for all he knows Pierre is a woman. On the other hand given the system of agreement we use, these facts are unsurprising since the gender features on 'lui' are the result of agreement, and thus remain uninterpreted.

⁸⁴ Here is her analysis of 'Mary believed it was raining':

(i)	Mary	PAST ₁ believed [λt_2 it	PAST ₂	was raining]
		con: $R_1(t_1, t_0)$		con: $R_2(t_2, t_2)$
		rel: $\{R_1\}$		rel: $\{R_1, R_2\}$
		tc: $R_1=<$		tc: $R_1=<$ or $R_2=<$

'con' is a feature whose value is a relation constraining the value of a variable with respect to the local evaluation time. Since (i) is interpreted on its simultaneous interpretation, both arguments of R_2 are just t_2 . Since the tense constraint tc requires that one of the two relations $\{R_1, R_2\}$ be temporal precedence, this correctly implies that the matrix tense must be interpreted as past.

Note that (i) can't be the only possible representation. In order to get the correct reading for 'Mary believes that John came', Abusch must presumably allow a non-simultaneous interpretation for the embedded tense:

(ii)	Mary	PRES ₁	believes [λt_2 John	PAST ₃	came]
		con: $R_1(t_1, t_0)$		con: $R_3(t_3, t_2)$	
		rel: $\{R_1\}$		rel: $\{R_2, R_3\}$	
		tc: $R_1=<$		tc: $R_1=<$ or $R_2=<$	

(I follow Abusch's convention of subscripting the relation associated with a given temporal argument 'with the index of that argument' (p. 30))

But since (ii) can be generated as well as (i), we can also have the following representation for 'Mary believed John came':

(iii)	Mary	PAST ₁ believed [λt_2 John	PAST ₃	came]
		con: $R_1(t_1, t_0)$		con: $R_3(t_3, t_2)$
		rel: $\{R_1\}$		rel: $\{R_2, R_3\}$
		tc: $R_1=<$		tc: $R_1=<$ or $R_2=<$

Given Abusch's constraint on past tense, it could be that both $R_1=<$ and $R_2=<$ (since her 'or' is inclusive). This, we suggest, is where Abusch's makes wrong predictions: in her system a past tense can always have a backward shifted reading, even if it is embedded under an attitude verb in the past.

⁸⁵ Consider an instance of so-called 'Double-Access Reading', in which the embedded present tense is semantically outside the scope of the attitude operator (the phenomenon will be discussed in greater detail in Chapter 5):

- (i) a. Bill believed that Mary is pregnant
 b. PAST₁ Bill believe-of PRES₂ λ₃ λ₀ [T₃ Mary be pregnant]
 c. <... T*...> λ<... T...> P. believes at t₁ [t₁ < T] ...
 λ<... t...> ... Mary is pregnant at T ...

b. is von Stechow's treatment (simplified - in his system PRES has a quantifier type, and must be further moved to leave in the argument position of 'believe-of' a trace of the individual type; this is orthogonal to the question at hand, and it can be assumed that PRES is of the individual type). c. is the formalization we would give (again, in simplified notation, without diacritics).

Several things have happened in b.: (a) 'believe that' has been changed to a verb that takes an additional time argument (believe-of ... that...); (b) PRES has been res-moved, and replaced by a variable bound by a λ-abstractor. Following Heim 1994, von Stechow gives the following entry for 'believe-of':

- (ii) [[believe-of]]^c (t_{res}) (R) (x) (t) (w) is defined only if c [=the discourse context -PS] supplies a suitable time-concept f_c such that f_c (w, t) = t_{res}.
 Where defined, [[believe-f]]^c (t_{res}) (R) (x) (t) (w) = 1 iff R(f_c(w', t'))(t')(w')=1 for all w' and t' compatible with x's belief in w at t.

⁸⁶ It is very dubious that there is:

- First, observe that res-movement is certainly not a conceptual necessity. The thrust of Kaplan's work on Quantifying In was precisely that formulas with variables that are free in the scope of an attitude operator can be treated like any other formulas, as long as special interpretive procedures are provided. In other words, Kaplan's point was that variables *could* appear free in an attitude environment in the logical syntax.

- Of course one could still argue that even though it is *possible* to devise systems in which a variable can remain free in the scope of an attitude operator, this is not the way natural language works. The argument would have to be that there is *syntactic* evidence for an analysis in which the 'res' is moved outside the syntactic scope of the operator. But this is precisely where theories that posit res-movement are particularly weak:

1. As Heim 1994 observes (fn. 25 p. 154) the result of the movement is non-standard:

(a) If one executes it *à la* Abusch, with the *res* and the complement forming a constituent (i.e. John believes [res [complement]]), one has to depart from compositionality, since 'the syntactic constituent consisting of res and complement is not a semantic unit'.

(b) If one does it *à la* Heim, with the moved element appearing as a sister to the verb (i.e. John [[believes res] [complement]], the movement itself is non-standard - as Heim further observes, 'one would normally expect the λ to appear on the sister constituent of the moved phrase, not on a lower node'.

2. In addition, res-movement does not obey any island constraints. For simplicity, consider simple cases involving individuals rather than time:

- (i) [Talking to Ortcutt] Ralph believes that if you are a spy, you must have caused a lot of trouble.

Here 'you' must be quantified in. If syntactic movement is involved, it must raise 'you' out of an *if*-clause - not an appealing result.

[Apparently the appeal of res-movement in these cases is that it facilitates the statement of a compositional semantics for propositional attitudes.]

⁸⁷ Here is his definition of the SOT rule (p. 134):

(i) The SOT rule [definitive version]:

If a tense feature B is the local tense feature of a tense feature A at LF, and A and B are occurrences of the same feature (i.e. either [+past] or [+pres]), A and the tense associated with A (if any) are optionally deleted.

N.B.: (i) The tense features include [+past] and [+pres] and nothing else.

(ii) A tense feature A is "in the scope" of a tense feature B iff B is associated with a common noun and asymmetrically c-commands A, or B is associated with a tense or a perfect and asymmetrically commands A.

(iii) A tense feature B is the local tense feature of a tense feature A iff A is "in the scope" of B and there is no tense feature C "in the scope" of B such that A is "in the scope" of C.

⁸⁸ Ducrot's contention was that the second reading is unavailable. However the facts are not so clear - or might be changing. D. Spector (p.c.) tells me that he heard the following sentence on *Apostrophe*, a literary program on French television which used to be very popular a few years ago:

(i) Et Mitterrand? Mitterrand, il nous emmerde

The intended reading seems to be that Mitterrand sends us to hell, i.e. he tells us 'Merde', which is not polite. And which suggests that the special meaning of the verb is to some extent available in the 3rd person.

The contrast between 1st and 3rd person is irrelevant for our purposes. We use 'emmerder' as a test for tense, and there I think the contrasts are relatively strong.

⁸⁹ As mentioned before, the status of the Russian past is problematic. By analogy with the Russian present, we might want to posit two entries:

PAST_{Rus}<,*t*

PAST_{Rus}<,*ʃ*

But this would make the wrong predictions for cases in which the past and the present compete for insertion in a node with the features <,*ʃ*,*t* [the past tense should always block the present, contrary to fact]. Another possibility is that the Russian past has a single entry specified only for the feature <:

PAST_{Rus}<

This does not cause any morphological problem. And it is also compatible with all the semantic facts, as far as I can tell.

⁹⁰ We hope that future work will determine which hypothesis is correct. Note also that, independently of the status of the Konjunktiv I in German, one would expect to find both cases of logophoric tense and of logophoric mood cross-linguistically. An obvious place to look is what has been called 'evidentials' in a variety of languages (e.g. Bulgarian, Tibetan, etc.). We leave for future research.

⁹¹ I. Heim points out that for her this example is deviant, among others because some of the verbs in the scope of the verb 'believe' appear in the indicative ('behaupten wird') while others are in the

Konjunktiv I ('habe'). In order to improve the example 'behaupten wird' should be replaced with 'behauptet werde'.

⁹²One important control is to make sure that for the informant 'heute' ('today') is a matrix and not an all-purpose indexical. This seems to be indeed the case here, but speakers might differ on this. Analogous tests with Martin Hackl have not confirmed our predictions, but again the work is extremely preliminary at this point.

⁹³An obvious question is whether similar facts hold of logophoric pronouns. But I am afraid I'll have to leave the study of Free Indirect Discourse in Ewe and Gokana for another occasion.

⁹⁴ Heim 1994 (p. 152, fn. 22) observes that Abusch's suggestion correctly predicts that the evaluation time of 'might' and 'ought' can be shifted under 'will':

(i) He will always be a student that ought to work harder.

⁹⁵ Abusch 1997 also treats 'will' as quantifying over times, with the following definition:

(i) $\lambda\phi \lambda t \lambda w \exists t' [t' > t \ \& \ \phi(t')(w)]$ (p. 38)

She comments:

'The discussion of 'will' suggests something about how we should understand 'intensional' in the present theory. The denotation [(i)] manipulates evaluation time, but it does not do anything essential with the world parameter. Thus if this definition is correct, it is clear that temporal intensionality is what is at issue. I do not think that this question should be considered settled, though, since one can imagine a treatment of 'will' according to which it quantifies worlds as well. This seems quite natural to me, since it would allow us to treat 'will' as a universal modal counterpart of the existential modal 'might'. For concreteness, though, I will adopt temporal intensionality as the criterion in the definition of tense constraints. This can be defined straightforwardly with reference to the type of the argument and/or the presence of an evaluation time abstractor on the argument at LF'. (p. 38)

⁹⁶ The effect is either non-existent or very weak when an attitude verb appears in the *consequent* of a conditional. I do not know why.

⁹⁷ Here is the problem we would have if we embedded the examples in (40) inside a when-clause:

- (i) a. When John knew that Mary was pregnant...
a'. #Quand Jean savait que Marie était enceinte...
b. When John knew that Mary is pregnant...
b'. #Quand Jean savait que Marie est enceinte

These sentences do not seem to be felicitous unless 'knew' is read as 'came to know'. The situation is clearer in French, since the use of the imperfect blocks the latter reading. But things are a little more subtle than this; in fact the French sentences can be made perfect in a context where Jean got Alzheimer's disease, and used to know things he has now forgotten. The problem with the sentences in (i) appears to be the following:

- Using the when-clause presupposes or implicates '...t the proposition does not hold at the utterance time
- But in general if someone knows something at time t, he also knows it at every later moment
- Therefore the sentences in (i) are odd, since they both presuppose that John knew p, and doesn't know it any more.

[Iatridou 1998 makes a somewhat similar observation].