

PFC/RR-89-17

DOE/ET-51013-277

**A Design Procedure for a Slotted Waveguide
With Probe-Fed Slots Radiating into Plasma**

Jeffrey A. Colborn

November 1989

**Department of Electrical Engineering
and
Plasma Fusion Center**

**Massachusetts Institute of Technology
Cambridge, Massachusetts 02139 USA**

**This work was supported by the USDOE Contract No. DE-AC02-78ET51013
and the Magnetic Fusion Energy Technology Fellowship Program administered
by Oak Ridge National Laboratory for the USDOE.**

A Design Procedure for a Slotted Waveguide With Probe-Fed Slots Radiating into Plasma

by

Jeffrey A. Colborn

ABSTRACT

A design procedure is developed for slotted-waveguide antennas with probe-fed slots. Radiation into a gyrotropic, plane-stratified medium is considered, nonzero waveguide wall thickness is assumed, and noncosinusoidal slot fields and arbitrary slot length up to about one free-space wavelength are allowed. External mutual coupling is taken into account by matching the tangential fields at the antenna surface. The particular case of longitudinal slots in the broad face of rectangular guide is analyzed. The motivation for this work is the design of such radiators for plasma heating and current-drive on thermonuclear fusion experiments, but some of the analysis is applicable to the probeless slotted waveguide used for avionics and communications.

INTRODUCTION

The coupling of electromagnetic waves from open-ended waveguides and slots into plasma was analyzed by several authors in the 1960's and early 1970's in order to treat the effects of the ionosphere on reentry-vehicle antennas.^{[1] [2] [3] [4]} However, these authors generally treated only one radiating element, used very crude plasma models, and allowed for at most one higher-order mode in the radiating aperture. In 1976, Brambilla analyzed the case of a "grill" of open-ended waveguides radiating in the lower-hybrid range of frequencies into a dense, magnetized plasma.^[5] He took full account of mutual coupling, and allowed an arbitrary number of higher-order waveguide modes. Brambilla was the first to show that the interaction of a radiating waveguide structure with a plasma is best analyzed in two stages: The interaction of a spectrum of waves with the body of a plasma should be studied using whatever physics is necessary for the problem of interest (e. g., wave propagation, Landau damping on electrons, nonlinear wave decay or absorption, ion heating), and the production of such near-field spectra should be studied by encapsulating the plasma characteristics into a reflection coefficient $\Upsilon(k)$ when analyzing the coupling of waves from the antenna to the plasma, where k is the wavenumber. His analysis has since been refined^{[6] [7] [8]} and computer codes are available.^[8] The slotted-waveguide radiator, a considerably more complicated device, was first analyzed by Stevenson,^[9] and his work has subsequently been highly refined by a number of researchers, particularly Elliot.^{[10] [11] [12] [13] [14] [15] [16]} Such antennas radiate when the slots are placed in such a position as to interrupt the wall currents of the dominant traveling mode in the guide, hence replacing them with displacement currents across the slots and yielding a source field for radiation. It was discovered very early^[17] that an alternative is to place the slots where they do not interrupt the dominant-mode currents, and instead feed the current across the slot by placing a probe nearby (see Figure 1), but such antennas have received relatively little attention. It has recently been discovered that the slotted-waveguide antenna can be used for

current-drive in magnetically confined plasmas for nuclear fusion research.^{[18] [19]} This paper describes a procedure for designing a slotted-waveguide radiator with probe-fed slots that can be used for such an application.

Existing procedures for designing slotted-waveguide radiators are not adequate to describe radiation into a dense magnetized plasma. For such media, the near-field spectrum, not the far-field pattern, is the function of merit, and waves with $|k_z| > \omega/c$ are desired, where k_z is the wave vector in the direction of the guide axis and the DC plasma magnetic field, as shown in Figure 2. Such waves, which do not propagate in free space, are best produced using probe-fed slots with alternating probe placement, as shown in Figure 1. The probeless slotted waveguide with alternating slot placement is unacceptable because its largest radiation lobes have $|k_y| > \omega/c$ but $|k_z| < \omega/c$. Several configurations may be useful, including longitudinal and transverse slots in rectangular guide as well as slots in coaxial transmission line. Here, the case of longitudinal probe-fed slots in the broad wall of a single rectangular guide is analyzed; the analysis can easily be extended to more than one guide or applied to the other guide types.

The goal of the present analysis is to find the required self-reflectances, Γ , of the slots, given the expected plasma characteristics and the desired fields at the face of the antenna. It is assumed from study of existing data (e.g.,^[20]) that a sufficiently broad band of self-reflectances can be produced by varying the probe depth, diameter, and y -position. The coordinates and slot-parameters used are shown in Figure 2. Slab geometry is used, and the guide is straight. The face of the antenna is flush with an infinite conducting sheet (e. g., the plasma vacuum chamber), and the plasma parameters do not vary in the y or z directions. The plasma is immersed in a DC magnetic field, which is in the z -direction, and the main waveguide propagates only the TE₁₀-mode. The plasma density is as shown in Figure 3, i. e., there is a vacuum region just outside the antenna, followed by a plasma region with some arbitrary initial density and density gradient. The vacuum region can be infinitesimally thin, but the plasma does not enter the slots. Inside

the waveguide, the slots do not couple to each other, i. e., the evanescent modes reflected into the guide by one slot do not reach another. The slots are rectangular, longitudinal, centered on the broad face of the guide, and are long, narrow, and fed by a centered probe such that only TE'_{n0} -modes are excited, where the prime indicates a slot-mode.

The outline of the calculation is as follows. First, a superposition of TE'_{n0} -modes is assumed to exist in each slot. The slots are treated as waveguides, with length equal to the wall thickness of the main waveguide and transverse dimensions equal to the dimensions of the slot. These modes are evanescent for slot lengths less than half a free-space wavelength ($2\ell < \lambda/2$), which is the case of greatest interest. This mode-superposition approach is less useful for $2\ell > \lambda$, but can be used for $\lambda/2 < 2\ell < \lambda$ by keeping track of the sign of k_x^2 for each slot mode. The fields outside the antenna are written as a superposition of plane waves in the narrow vacuum region, and the plasma response is encapsulated into a reflection coefficient at $x = 0$ and a radiation condition at large x . The fields are then matched at $x = 0$, yielding NP complex equations for the $2NP$ slot-modes, where P is the number of slots, and N is the number of slots modes considered, i. e., the infinite sum of slot modes is truncated at $n = N$. Successive orders of the problem are then analyzed. Starting with the zeroth-order problem, we assume only TE'_{10} -modes exist in the slots, so $N = 1$. The desired self-reflectances of the slots are then found. Higher-order modes are then successively allowed, and the problem is solved up to third order, with one ad-hoc assumption required. Higher-order solutions require an increasing number of similar ad-hoc assumptions. In terms of the antenna/plasma coupling, experience has shown that very good convergence can be achieved with a third- or fourth-order treatment.^[5] However, considering the approximations required regarding the plasma characteristics, geometry, and probe coupling, and the neglect of internal mutual coupling, a third-order solution is probably more than adequate.

EXTERNAL COUPLING

First the external coupling is calculated; a superposition of evanescent modes is assumed to exist in the slots, and these fields are matched to the external near fields at the antenna surface, in a manner similar to that of Brambilla.^[5]

The fields in the slots are the following:

$$\mathbf{E}^{slot} = \hat{y} \sum_{p=1}^P \Theta_p(y, z) \sum_{n=1}^{\infty} (\Phi_{pn} e^{-\gamma_n z} + R_{pn} e^{\gamma_n z}) \sin \frac{n\pi(z - z_p)}{2\ell} \quad (1)$$

$$\begin{aligned} \mathbf{H}^{slot} = & \frac{1}{j\omega\mu_0} \sum_{p=1}^P \Theta_p(y, z) \sum_{n=1}^{\infty} \left[\hat{x} (\Phi_{pn} e^{-\gamma_n z} + R_{pn} e^{\gamma_n z}) \frac{n\pi}{2\ell} \cos \frac{n\pi(z - z_p)}{2\ell} \right. \\ & \left. + \hat{z} (\Phi_{pn} e^{-\gamma_n z} - R_{pn} e^{\gamma_n z}) \gamma_n \sin \frac{n\pi(z - z_p)}{2\ell} \right], \end{aligned} \quad (2)$$

where Φ_{pn} and R_{pn} are the complex amplitudes of the n th forward- and backward-decaying evanescent modes in the p th slot, $\gamma_n = \sqrt{(n\pi/2\ell)^2 - (\omega/c)^2}$ is the decay constant of the n th mode, 2ℓ is the slot length, w is the slot width, z_p and y_p are the z - and y -coordinates of the left and top, respectively, of the p th slot, and $\Theta_p = 1$ for $z_p < z < z_p + 2\ell$ and $y_p < y < y_p + w$, and $\Theta_p = 0$ otherwise.

The tangential fields in the vacuum region ($x > 0$) can be written as Fourier integrals. They are the following:

$$E_y^V = \int_{-\infty}^{\infty} [\sigma(k_y, k_z) e^{-jk_z x} + \rho(k_y, k_z) e^{jk_z x}] e^{-jk_y y - jk_z z} dk_y dk_z \quad (3)$$

$$H_z^V = \frac{1}{\omega\mu_0} \int_{-\infty}^{\infty} k_z [\sigma(k_y, k_z) e^{-jk_z x} - \rho(k_y, k_z) e^{jk_z x}] e^{-jk_y y - jk_z z} dk_y dk_z. \quad (4)$$

To satisfy causality at large positive and negative y and z , the above integrals must be performed along the contours in the complex k_y - and k_z -planes shown in Figure 4. Branch cuts must be introduced as shown along the horizontal axes, and the integration path must be above the axis in the left half-plane and below the axis in the right half-plane.^{[5] [8]}

The plasma reflection coefficient is defined by

$$\rho(k_y, k_z) = -\Upsilon(k_y, k_z)\sigma(k_y, k_z). \quad (5)$$

Fairly sophisticated expressions for $\Upsilon(k_y, k_z)$ are available;^{[5] [7] [8]} it will not be discussed further here. The y -components of the vacuum and slot electric-field spectra are now matched at $x = 0$. The spectrum of the slot electric-field is defined as

$$\bar{E}_y^{slot}(k_y, k_z) = \frac{1}{2\pi} \int_{-\infty}^{\infty} \int_{-\infty}^{\infty} E_y^{slot}(y, z) e^{jk_y y + jk_z z} dy dz \quad (6)$$

which gives

$$\begin{aligned} \bar{E}_y^{slot} = & \sum_{p=1}^P \sum_{n=1}^{\infty} (\Phi_{pn} + R_{pn}) \left(\frac{e^{jk_y y_p} - e^{jk_y (y_p + w)}}{4\pi k_y} \right) \\ & \times \left[\frac{e^{jn\pi + jk_z (z_p + 2\ell)} - e^{jk_z z_p}}{j(\frac{n\pi}{2\ell} + k_z)} - \frac{e^{-jn\pi + jk_z (z_p + 2\ell)} - e^{jk_z z_p}}{j(-\frac{n\pi}{2\ell} + k_z)} \right] \end{aligned} \quad (7)$$

Writing the last two factors in Equation 7 as $F_{pn}(k_y, k_z)$ for compactness yields, upon matching the electric field spectra at $x = 0$,

$$\sigma(k_y, k_z) (1 - \Upsilon(k_y, k_z)) = \sum_{p=1}^P \sum_{n=1}^{\infty} (\Phi_{pn} + R_{pn}) F_{pn}(k_y, k_z). \quad (8)$$

The magnetic fields must also be matched, but due to surface currents on the outside of the waveguide, these fields are only equal at the slots. Therefore, the field outside the slots is inverse transformed and matched to $H_z(y, z)$ in the slots, yielding

$$\begin{aligned} & \frac{1}{\omega\mu_0} \int_{-\infty}^{\infty} \int_{-\infty}^{\infty} k_z \sigma(k_y, k_z) \left(1 + \Upsilon(k_y, k_z)\right) e^{-jk_y y - jk_z z} dk_y dk_z \\ &= \sum_{p=1}^P \Theta_p(y, z) \sum_{n=1}^{\infty} (\Phi_{pn} - R_{pn}) \left(\frac{\gamma_n}{j\omega\mu_0}\right) \sin \frac{n\pi(z - z_p)}{2\ell}. \end{aligned} \quad (9)$$

The orthogonality of the slot fields is now used to get a set of equations for the unknown coefficients Φ_{pn} and R_{pn} . Multiplying both sides of Equation 9 by $\Theta_q(y, z) \sin \frac{m\pi(z - z_q)}{2\ell}$ and integrating both sides over y and z gives the following:

$$\begin{aligned} & \frac{1}{\omega\mu_0} \int_{z_q}^{z_q+2\ell} \int_{y_q}^{y_q+w} \sin \frac{m\pi(z - z_q)}{2\ell} \left\{ \int_{-\infty}^{\infty} \int_{-\infty}^{\infty} k_z \sigma(k_y, k_z) \right. \\ & \left. (1 + \Upsilon(k_y, k_z)) e^{-jk_y y - jk_z z} dk_y dk_z \right\} dy dz = \frac{\ell w \gamma_m}{j\omega\mu_0} (\Phi_{qm} - R_{qm}). \end{aligned} \quad (10)$$

Substituting from Equation 8, switching index names, truncating the sum over slot modes at $n = N$, and defining $V_{pn} \equiv \Phi_{pn} + R_{pn}$ and $I_{pn} \equiv \Phi_{pn} - R_{pn}$ yields a set of NP complex external coupling equations relating the V_{pn} 's and the I_{pn} 's:

$$I_{pn} = \sum_{q=1}^P \sum_{m=1}^N Y_{pnqm} V_{qm}. \quad (11)$$

where

$$\begin{aligned} Y_{pnqm} &= \frac{j}{\ell w \gamma_n} \int_{-\infty}^{\infty} \int_{-\infty}^{\infty} \sqrt{(\omega/c)^2 - k_y^2 - k_z^2} \\ & F_{qm}(k_y, k_z) F_{np}^*(k_y, k_z) \left(\frac{1 + \Upsilon(k_y, k_z)}{1 - \Upsilon(k_y, k_z)}\right) dk_y dk_z, \end{aligned} \quad (12)$$

the Y_{pnqm} 's are the mutual admittances, and the I_{pn} 's and V_{pn} 's are the slot mode "currents" and "voltages", respectively.

Note from Equation 8 that if $\Upsilon(k_y, k_z) = 0$ (radiation into free space) the shape of the radiated spectrum $\sigma(k_y, k_z)$ is just given by the Fourier transform of the fields at $x = 0$.

Probe Coupling

The complex coefficients of the TE₁₀-modes scattered into the guide by each probe-fed slot are now related to the slot-modes via the probe. Any reactive behavior of the probe-fed slot is assumed to result from a phase difference between the incident waveguide mode and the probe current, rather than between the probe current and the scattered modes. This is because reactive fields near the probe will interfere with the relationship between the incident mode field and the probe current, but will not affect the coupling of the probe to TE₁₀-modes traveling away from it. It is now assumed that when the p th probe is excited, a fraction ϵ_p of its current appears as displacement current across the p th slot. This fraction ϵ_p can be determined by bench measurements, and it should be of similar magnitude as the analogous quantity for the probeless slotted waveguide. Ignoring fringing fields, the probe current is then given by

$$\begin{aligned} \iota_p &= \frac{j\omega}{2\epsilon_p} \int_{z_p}^{z_p+2\ell} \int_{-\tau}^0 \sum_{n=1}^{\infty} (\Phi_{pn} e^{-\gamma_n x} + R_{pn} e^{\gamma_n x}) \sin \frac{n\pi(z-z_p)}{2\ell} dx dz \\ &= \sum_{\substack{n=1 \\ n \text{ odd}}}^{\infty} \frac{j2\omega\ell}{n\pi\gamma_n\epsilon_p} [\Phi_{pn}(e^{\gamma_n\tau} - 1) + R_{pn}(1 - e^{-\gamma_n\tau})] \end{aligned} \quad (13)$$

where ι_p is the current of the p th probe and τ is the waveguide wall-thickness. The amplitudes of the scattered TE₁₀-modes may then be found by equating the power

exerted on these modes by the probe with the poynting flux traveling away from the probe in the guide:

$$P = -\frac{1}{2} \int_V \mathbf{E} \cdot \mathbf{J}^* dV = \frac{1}{2} \int_S (\mathbf{E}_{10} \times \mathbf{H}_{10}^*) \cdot d\mathbf{A}. \quad (14)$$

Assuming a probe current of $\mathbf{J}_p = \hat{x}\iota_0\Omega(x)\delta(y - \xi_p - w/2)\delta(z - z_p - \ell)$ gives $P = -s_p B_{10}^p \iota_0^* \sin(\pi\xi_p/a)$, where $\Omega = 1$ for $-s_p - \tau < x < -\tau$ and $\Omega = 0$ otherwise, and s_p is the probe length. Other models for $J(x)$ along the probe can equally well be used, but the probe diameter must be small enough that it scatters waves symmetrically. Thus

$$B_{10}^p = C_{10}^p = -\frac{2s_p \iota_0 \omega \mu_0}{k_g a b} \sin \frac{\pi\xi_p}{a}. \quad (15)$$

Substituting for ι_p gives

$$B_{10}^p = C_{10}^p = \sum_{\substack{n=1 \\ \text{nodd}}}^{\infty} K_{pn} [\Phi_{pn} (e^{\gamma_n \tau} - 1) + R_{pn} (1 - e^{-\gamma_n \tau})] \quad (16)$$

where

$$K_{pn} = -\frac{4js_p \omega^2 \mu_0 \ell}{n\gamma_n \pi k_g a b \epsilon_p} \sin \frac{\pi\xi_p}{a}. \quad (17)$$

Inclusion of the slot fringing fields would increase the magnitude of K_{pn} .

ZERO-ORDER SOLUTION

The zeroth-order problem is now analyzed, in which it is assumed that only TE'_{10} -modes exist in the slots, hence $N = 1$. The complex slot modes can be

determined from the P complex external coupling equations 11 and the pattern requirements on the amplitudes and phases of the slot voltages. Typical requirements are that at $x = 0$ the amplitudes are equal and the phase of the voltage of the p th slot is $(p - 1)(\pi - k_g d)$, where d is the slot spacing (uniform). Dropping the $n = 1$ subscript, we get the following set of $4P$ real equations in $4P$ unknowns:

$$\text{Re}[I_p] = \text{Re} \left[\sum_{q=1}^P Y_{pq} V_q \right] \quad (18)$$

$$\text{Im}[I_p] = \text{Im} \left[\sum_{q=1}^P Y_{pq} V_q \right] \quad (19)$$

$$|V_p| = \text{known constant (or otherwise specified)} \quad (20)$$

$$\angle V_p = (p - 1)(\pi - k_g d) \text{ (or otherwise specified)} \quad (21)$$

The matrix elements Y_{pq} can be determined (this involves numerical integrations), and this set of equations can then easily be solved for the complex slot currents I_p , which will depend on the plasma parameters (and the vacuum-gap thickness x_0 , as shown in Figure 3) and will determine the power radiated from each slot. These coefficients will now be related to the TE_{10} -modes traveling in the guide and the required self-impedance properties of each slot.

The situation for the p th slot in an array is shown in Figure 5. The guide mode complex coefficients A_p, B_p, C_p, D_p are defined at each respective probe (slot center), and the following relations apply:

$$B_p = A_p \Gamma_p + D_p (1 + \Gamma_p) + B_{p,ext} = B'_p + D_p \quad (22)$$

$$C_p = A_p(1 + \Gamma_p) + D_p\Gamma_p + C_{p,ext} = C'_p + A_p \quad (23)$$

$$A_p = C_{p-1}e^{-jk_g d} \quad (24)$$

$$D_p = B_{p+1}e^{jk_g d}. \quad (25)$$

The coefficients A_p , B_p , C_p , and D_p are for the *total* waves traveling toward and away from the p th slot as shown in Figure 5; Γ_p , the reflectance of the p th slot, is the ratio B/A for the isolated slot with a waveguide mode A incident from the left only; the *ext* subscript refers to guide waves caused by external coupling from other slots; and the primed modes are those scattered from the slot. Because the probe-fed slot is a symmetric scatterer, $C_{p,ext} = B_{p,ext}$ and $C'_p = B'_p$, as will be used henceforth.

Equations 23 and 24 give $A_p = (B'_p + A_{p-1})e^{-jk_g d}$, and Equations 22 and 25 give $D_p = (B'_{p+1} + D_{p+1})e^{jk_g d}$. These have the solutions

$$A_p = e^{-jk_g d(p-1)} \left[\sum_{r=1}^{p-1} B'_r e^{-jk_g d(1-r)} + A_1 \right] \quad p > 1 \quad (26)$$

and

$$D_{p-1} = e^{-jk_g d(P-p+2)} \left[\sum_{r=p}^P B'_r e^{jk_g d(P-r+1)} + D_P e^{jk_g d} \right] \quad p > 1 \quad (27)$$

We are free to specify either A_1 or D_P ; we set $D_P \equiv 0$, equivalent to specifying a matched load in the guide beyond the antenna. The magnitude of A_1 is then determined from power balance over the entire antenna:

$$|A_1|^2 - |B_1|^2 - |C_P|^2 = \frac{2\omega\mu_0}{abk_g} \sum_{p=1}^P P_p^{rad} \quad (28)$$

Where P_p^{rad} is the known power leaving the p th slot. The phase of A_1 can be set arbitrarily, and this determines the phase of Γ_1 . We choose $\angle A_1 \equiv B'_1$. For infinitely thin waveguide walls, the desired V_p 's give the phases of the B'_p 's to be $\angle B'_p = (p-1)(\pi + k_g d) - \pi/2$, and from Equation 26 we see that this implies that the A_p 's are in phase with the B'_p 's. For nonzero waveguide wall thickness, this is nearly true.

A power-balance equation is now derived for each slot. The power leaving the p th slot is given by

$$P_p^{rad} = \frac{1}{2} \text{Re} \int_{z_p}^{z_p+2\ell} \int_{y_p-w/2}^{y_p+w/2} \mathbf{E} \times \mathbf{H}^* \cdot \hat{\mathbf{x}} \, dy \, dz. \quad (29)$$

Writing the known slot-mode coefficients as $\Phi = \phi e^{j\varphi}$ and $R = r e^{j\rho}$ gives

$$P_p^{rad} = \frac{w\ell}{\omega\mu_0} \gamma_1 \phi_p r_p \sin(\varphi_p - \rho_p). \quad (30)$$

Balancing power at the p th slot gives

$$|A_p|^2 + |D_p|^2 - |B_p|^2 - |C_p|^2 = \frac{2\omega\mu_0}{abk_g} P_p^{rad} \quad (31)$$

using Equations 22 and 23, this reduces to

$$B_p^{i*} D_p + B_p' D_p^* + B_p^{i*} A_p + B_p' A_p^* - 2|B_p'|^2 = \frac{2\omega\mu_0}{abk_g} P_p^{rad} \quad (32)$$

The B_p' 's can now be determined by iteration as follows. Defining $B_p' \equiv b_p' e^{j\beta_p'}$, from Equation 16 the β_p' 's can be determined, and from Equation 32,

$$b_p' = \frac{2\omega\mu_0 P_p^{rad}}{abk_g (D_p e^{-j\beta_p'} + D_p^* e^{j\beta_p'} + A_p e^{-j\beta_p'} + A_p^* e^{j\beta_p'})}. \quad (33)$$

Initial guesses are now made for the b'_p 's, and Equations 26 and 27 are solved for the A_p 's and D_p 's. These are plugged into Equation 33 and the new b'_p 's are computed. This process is iterated until sufficient accuracy is attained. The A_p 's, B_p 's, and D_p 's can then be determined from Equations 26, 27 and 22. Some information about the physical probe characteristics can also now be obtained from Equation 17.

The unknown Γ_p 's can now be found by considering the following two situations, in order to isolate the $B_{p,ext}$'s. In situation X , perfect absorbers are placed on both sides of the p th slot, and the other slots are replaced by equivalent magnetic current sources skin-tight against the old slot positions such that they produce slot voltages exactly the same as in the original array. For this case, the external coupling equation is

$$I_{pX} - Y_{pp}V_{pX} = \sum'_{q=1}^P Y_{pq}V_q \quad (34)$$

where the right-hand side is known, and the primed sum means the $q = p$ term is excluded. In situation Y , again only the p th slot exists, and it is excited internally by equivalent sources such that A_p and D_p are the same as for the original array. The external coupling equation for this situation is

$$I_{pY} - Y_{pp}V_{pY} = 0 \quad (35)$$

In addition, we know that $\Phi_{pX} + \Phi_{pY} = \Phi_p$ and $R_{pX} + R_{pY} = R_p$, where Φ_p and R_p are known. Combining Equations 34 and 35 then gives

$$\Phi_{pY} = \frac{\Phi_p(1 - Y_{pp}) - R_p(1 + Y_{pp}) - \sum'_{q=1}^P Y_{pq}(\Phi_q + R_q)}{1 - Y_{pp}} \quad (36)$$

$$R_{pY} = \frac{\Phi_p(1 - Y_{pp}) - R_p(1 + Y_{pp}) - \sum_{q=1}^P Y_{pq}(\Phi_q + R_q)}{1 + Y_{pp}} \quad (37)$$

Equations 16 and 22 are then applied to the Y situation, yielding the desired self-reflectances of the probe-fed slots in the full array:

$$\Gamma_p = \frac{B'_{pY}(\Phi_{pY}, R_{pY})}{A_p + D_p} \quad (38)$$

This completes the solution, assuming only TE'_{10} modes exist in the slots.

FIRST-ORDER SOLUTION

It will generally be true that the magnitudes of the $n = 1$ modes will be substantially greater than those of the $n = 2$ modes, which will be greater than those of the $n = 3$ modes, etc. However, a simple perturbative solution for the higher-order modes, that is, assuming the introduction of the $(n + 1)$ th modes does not affect the n th modes, yields $V_{n+1} = 0$ to all orders, which does not introduce any corrections to the radiated spectrum, hence it is useless.

However, a first-order solution can be obtained by recognizing that since the $n = 2$ modes cannot couple current to the probes, they must have zero poynting flux in the slots. For the design specification, instead of dictating the $n = 1$ complex slot voltages as before, we now dictate the probe current amplitudes and phases as those found during the zeroth-order analysis, thus fixing the total displacement current across the slot and the power radiated. This gives the following system of $8P$ real equations, which can be solved for the new $n = 1$ and $n = 2$ modes:

$$I_{pn} = \sum_{q=1}^P \sum_{m=1}^2 Y_{pnqm} V_{qm} \quad (39)$$

$$l_p = l_p \Big|_{\substack{\text{zeroth} \\ \text{order}}} \quad (40)$$

$$\text{Im} [V_{p1} I_{p1}^*] = \text{Im} [V_{p1} I_{p1}^*] \Big|_{\substack{\text{zeroth} \\ \text{order}}} \quad (41)$$

$$\text{Im} [V_{p2} I_{p2}^*] = 0 \quad (42)$$

SECOND-ORDER SOLUTION

To solve the second-order problem, the ad-hoc assumption is made that the introduction of the $n = 3$ modes does not affect the ratio Φ_{p1}/R_{p1} of the $n = 1$ modes obtained from the first-order analysis, although the magnitudes and phases of Φ_{p1} and R_{p1} are allowed to change together so as to compensate for the contributions to the probe current and radiated power from the newly introduced $n = 3$ modes. The following set of $12P$ real equations is solved for the $6P$ unknown slot modes:

$$I_{pn} = \sum_{q=1}^P \sum_{m=1}^3 Y_{pnqm} V_{qm} \quad (43)$$

$$l_p = l_p \Big|_{\substack{\text{zeroth} \\ \text{order}}} \quad (44)$$

$$P_{p1}^{rad} + P_{p3}^{rad} = P_0^{rad} \quad (45)$$

$$\text{Im} [V_{p2} I_{p2}^*] = 0 \quad (46)$$

$$\frac{V_{p1} + I_{p1}}{V_{p1} - I_{p1}} = \frac{V_{p1} + I_{p1}}{V_{p1} - I_{p1}} \Big|_{\substack{\text{first} \\ \text{order}}} \quad (47)$$

THIRD-ORDER SOLUTION

For the third-order solution, the additional assumption is made that the introduction of the $n = 4$ modes does not affect the ratio Φ_{p2}/R_{p2} of the $n = 2$ modes obtained from the second-order analysis, although the magnitudes and phases of Φ_{p2} and R_{p2} are allowed to change together. Part of this is redundant with Equation 46, which says that Φ_{p2} and R_{p2} are in phase or one of them is zero. Dropping the $n = 2$ power balance (Equation 46) as redundant gives the following $16P$ real equations for the $8P$ complex slot modes with $N = 4$:

$$I_{pn} = \sum_{q=1}^P \sum_{m=1}^4 Y_{pnqm} V_{qm} \quad (48)$$

$$l_p = l_p \Big|_{\text{zerath order}} \quad (49)$$

$$P_{p1}^{rad} + P_{p3}^{rad} = P_0^{rad} \quad (50)$$

$$\text{Im} [V_{p4} I_{p4}^*] = 0 \quad (51)$$

$$\frac{V_{p1} + I_{p1}}{V_{p1} - I_{p1}} = \frac{V_{p1} + I_{p1}}{V_{p1} - I_{p1}} \Big|_{\text{first order}} \quad (52)$$

$$\frac{V_{p2} + I_{p2}}{V_{p2} - I_{p2}} = \frac{V_{p2} + I_{p2}}{V_{p2} - I_{p2}} \Big|_{\text{first order}} \quad (53)$$

This process can be carried on *ad infinitum*. However, considering the approximations involved regarding the plasma (e. g., plane stratified and not entering the slots), the probe coupling, and the neglect of internal mutual coupling, the third-order analysis is probably more than adequate.

CONCLUSIONS

A design procedure has been presented for a slotted-waveguide antenna with probe-fed slots radiating into a gyrotropic, plane-stratified medium. Given the desired slot-voltages or probe currents, the required self-reflectances of the probe-fed slots (as measured in isolation, radiating into free space) are found. It is hoped that others will extend this work. In particular, a rigorous theoretical and/or experimental analysis of the impedance properties of an isolated probe-fed slot and the fraction ϵ of probe current that appears as displacement current across the slot as a function of probe placement and dimensions is essential before such antennas can be produced. Internal mutual coupling should be taken into account, and the probe-to-slot coupling model should be checked experimentally and improved if needed.

ACKNOWLEDGEMENTS

This work was supported by USDOE Contract #DE-AC02-78ET51013 and the Magnetic Fusion Energy Technology Fellowship Program Administered by Oak Ridge National Laboratory for the USDOE. Helpful comments by R. R. Parker are gratefully acknowledged.

REFERENCES

- [1] A.T. Villeneuve, "Admittance of Waveguide Radiating into Plasma Environment," *IEEE Trans. Antennas Propagat.*, vol. AP-13 pp. 115-121, Jan. 1965.
- [2] J. Galejs and M.H. Mentzoni, "Waveguide admittance for Radiation into Plasma Layers," *IEEE Trans. Antennas Propagat.*, vol. AP-15 pp. 465-470, May 1967.
- [3] W.F. Croswell, et. al., "The input Admittance of a Rectangular Waveguide-fed Aperture under an Inhomogeneous Plasma: Theory and Experiment," *IEEE Trans. Antennas Propagat.*, vol. AP-16, pp. 475-487, July 1968.
- [4] M.C. Bailey, "The Impedance Properties of Dielectric-Covered Narrow Radiating Slots in the Broad Face of a Rectangular Waveguide," *IEEE Trans. Antennas Propagat.*, vol. AP-18, pp. 596-603, Sept. 1970.
- [5] M. Brambilla, "Slow-wave Launching at the Lower Hybrid Frequency Using a Phased Waveguide Array," *Nucl. Fusion* vol. 16, pp. 47-54, Jan. 1976.
- [6] M. Brambilla, "Waveguide Launching of Lower Hybrid Waves," *Nucl. Fusion* vol. 19, pp. 1343-1357, Oct. 1979.
- [7] A. Bers, K.S. Theilhaber, "Three-dimensional Theory of Waveguide-Plasma Coupling," *Nucl. Fusion* vol. 23, pp. 41-48, Jan. 1983.
- [8] R.I. Pinsky, et. al., "Calculation of Coupling to Slow and Fast Waves in the LHRF from Phased Waveguide Arrays," *Nucl. Fusion* vol. 26, pp. 941-954, July 1986.
- [9] A.F. Stevenson, "Theory of Slots in Rectangular Waveguides," *J. Appl. Phys.*, vol. 19, pp. 24-38, Jan. 1948.
- [10] A.A. Oliner, "The Impedance Properties of Narrow Radiating Slots in the Broad Face of Rectangular Waveguide," *IRE Trans. Antennas Propagat.*, vol. AP-5, pp. 4-20, Jan. 1957.
- [11] T. Vu Khac and C.T. Carson, "Impedance Properties of a Longitudinal Slot Antenna in the Broad Face of a Rectangular Waveguide," *IEEE Trans. Antennas Propagat.*, vol. AP-21, pp. 708-710 Sept. 1973.
- [12] R.S. Elliot and L.A. Kurtz, "The Design of Small Slot Arrays," *IEEE Trans. Antennas Propagat.*, vol. AP-26, pp. 214-219, Mar. 1978.
- [13] R.S. Elliot, "An Improved Design Procedure for Small Arrays of Shunt Slots," *IEEE Trans. Antennas Propagat.*, vol. AP-31, pp. 48-53, Jan. 1983.
- [14] G.J. Stern and R.S. Elliot, "Resonant Length of Longitudinal Slots and Validity of Circuit Representation: Theory and Experiment," *IEEE Trans. Antennas Propagat.*, vol. AP-33, pp. 1264-1271, Nov. 1985.

- [15] R.S. Elliot and W.R. O'Loughlin, "The Design of Slot Arrays Including Internal Mutual Coupling," *IEEE Trans. Antennas Propagat.*, vol. AP-34 Sept. 1986.
- [16] L.G. Josefsson, "Analysis of Longitudinal Slots in Rectangular Waveguides," *IEEE Trans. Antennas Propagat.*, vol. AP-35, pp. 1351-1357, Dec. 1987.
- [17] R.E. Clapp, "Probe-fed Slots as Radiating Elements in Linear Arrays," M.I.T. Rad. Lab Report #455, Jan. 25, 1944.
- [18] J.A. Colborn, "Current-Drive on the Versator-II Tokamak with a Slotted-Waveguide Fast-Wave Coupler," Master's Thesis, Massachusetts Institute of Technology, Cambridge, MA, Nov. 1987, and MIT Plasma Fusion Center Report #RR-87-20 (1987).
- [19] J.A. Colborn, et. al., "Fast-Wave Slotted-Waveguide Coupler on Versator-II," AIP Conf. Proc. #159, American Institute of Physics, New York (1987), pp. 123-127.
- [20] N. Marcuvitz, "Waveguide Handbook," vol. 10, M.I.T. Rad. Lab. Ser., McGraw-Hill, New York, pp. 271-273, 1951.

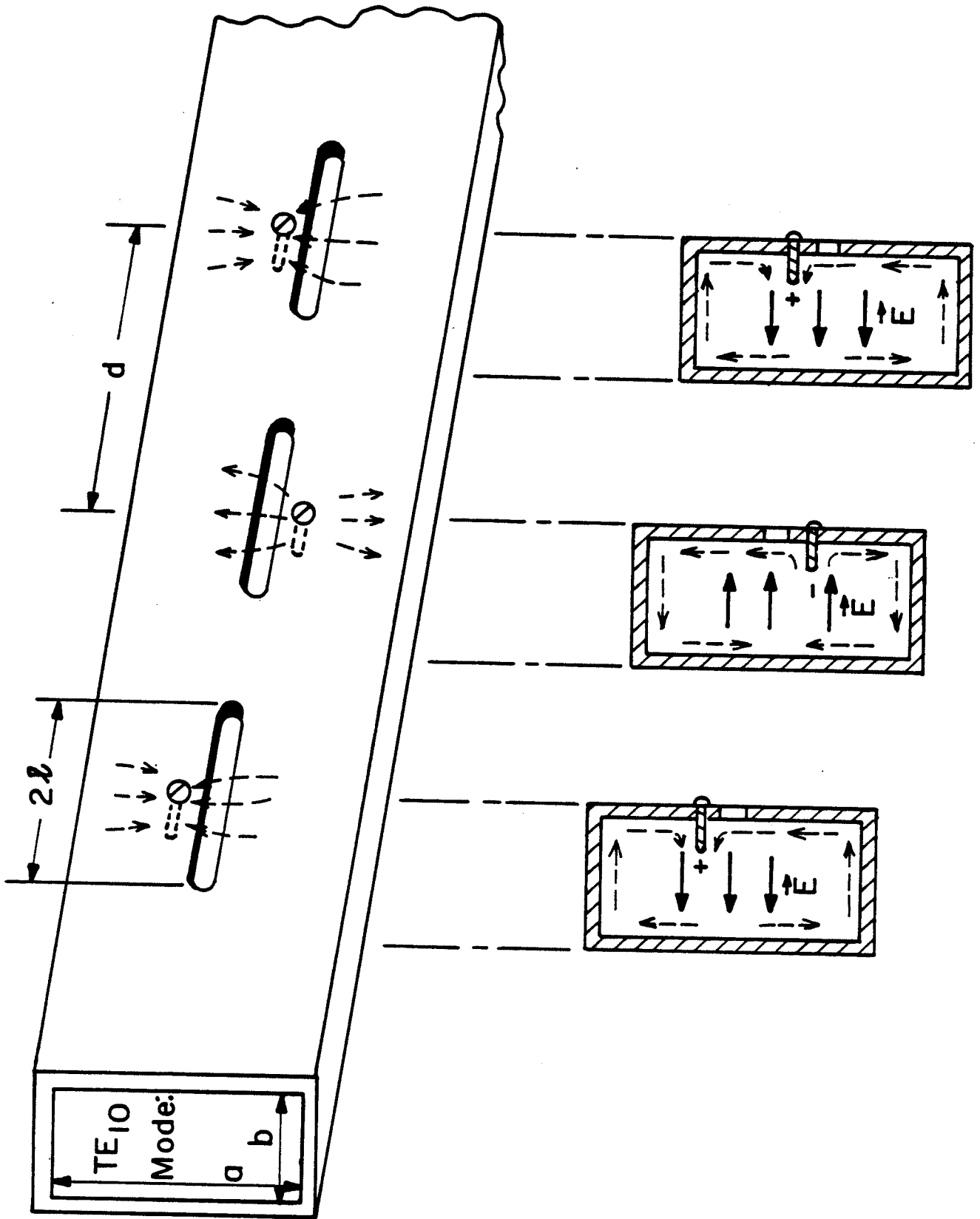

Figure 1

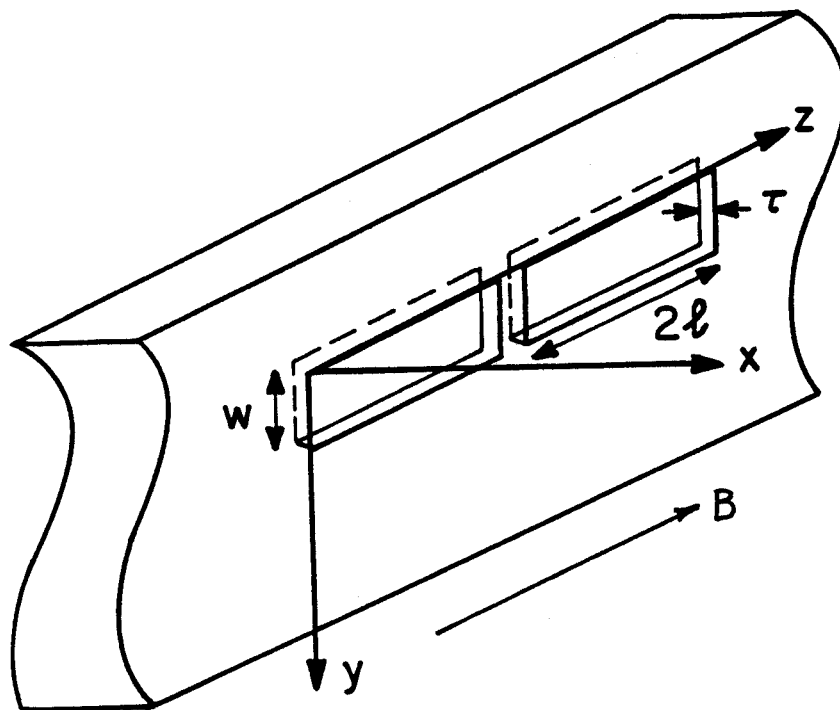

Figure 2

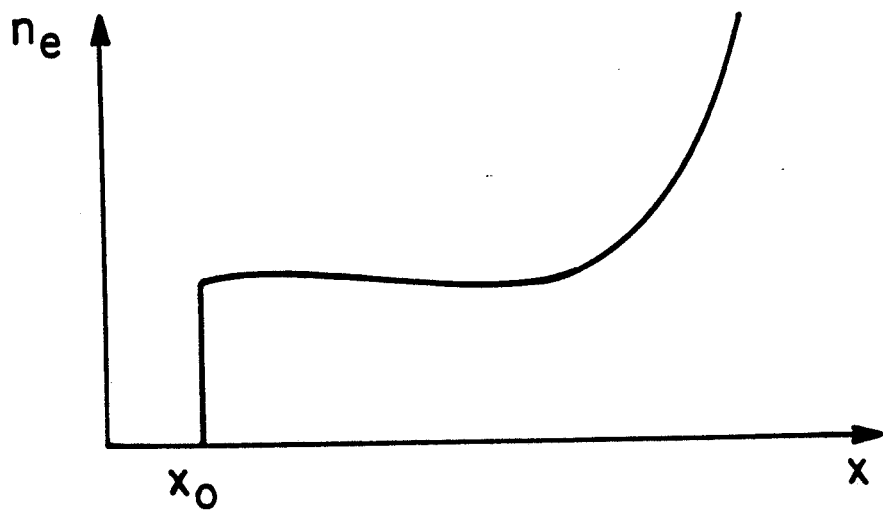

Figure 3

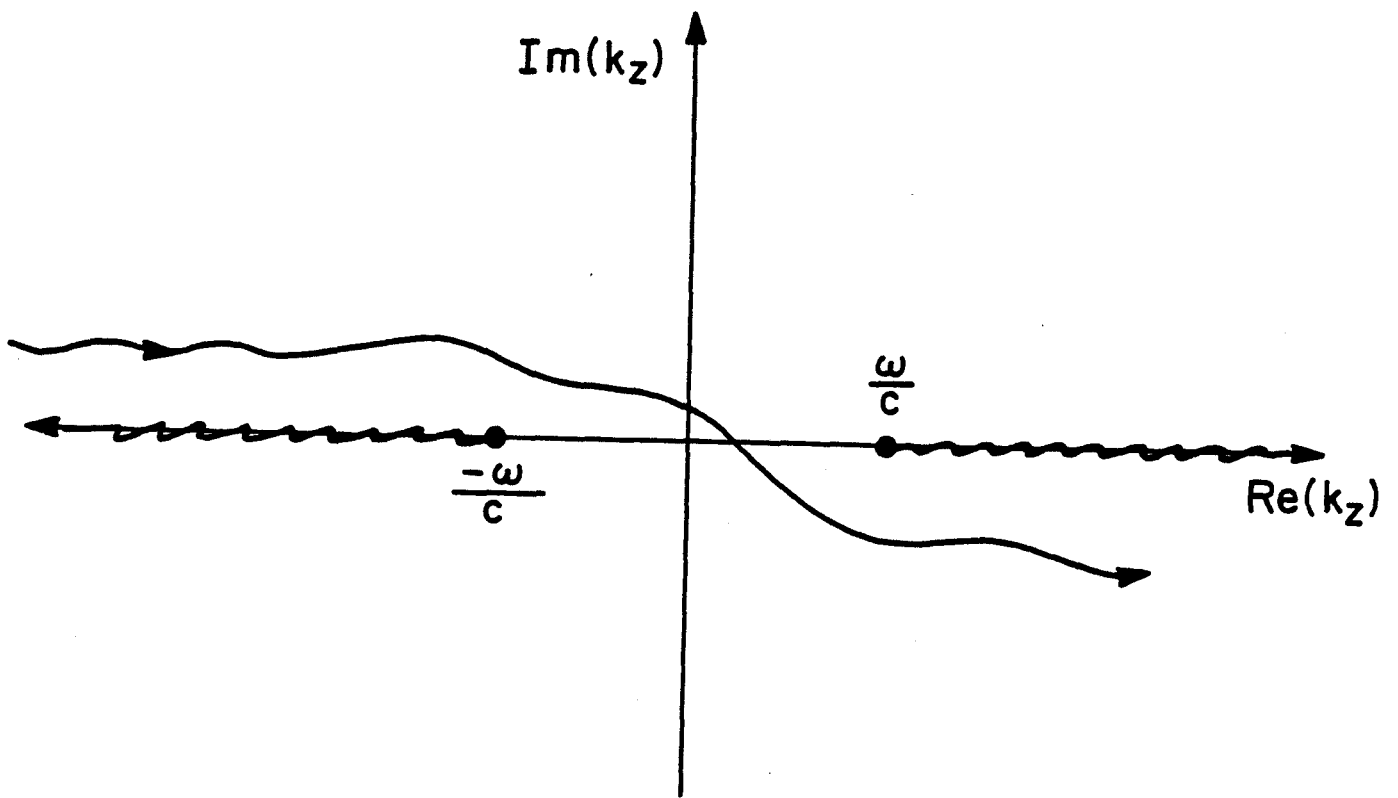

Figure 4

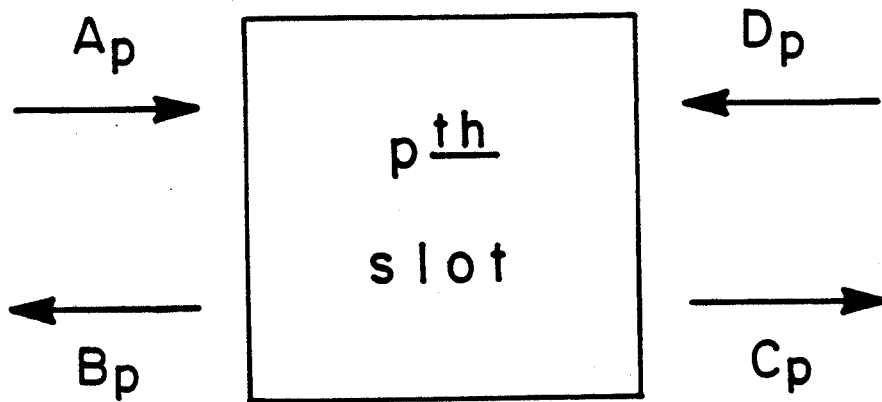

Figure 5