

# WARSHIP: A MEMORIAL IN ANTITHESIS

by  
**Andre Victor Tchelistcheff**  
B.A. Architecture  
University of California, Berkeley  
May 1984

SUBMITTED TO THE DEPARTMENT OF ARCHITECTURE  
IN PARTIAL FULFILLMENT OF THE REQUIREMENTS  
FOR THE DEGREE OF

MASTER OF ARCHITECTURE

AT THE  
MASSACHUSETTS INSTITUTE OF TECHNOLOGY  
FEBRUARY 1992

© Andre V. Tchelistcheff 1992. All Rights Reserved

The author hereby grants to MIT permission to reproduce and to distribute copies of this thesis document in whole or in part.

Signature of Author

Andre V. Tchelistcheff  
Department of Architecture, January 17, 1992

Certified by

Fernando Domeyko  
Lecturer in Architecture, Thesis Supervisor

Accepted by

Renée Y. Chow  
Chairman, Departmental Committee on Graduate Students

MASSACHUSETTS INSTITUTE  
OF TECHNOLOGY

FEB 24 1992

LIBRARIES

Rotch



# WARSHIP: A MEMORIAL IN ANTITHESIS

by

Andre Victor Tchelistcheff

SUBMITTED TO THE DEPARTMENT OF ARCHITECTURE ON JANUARY 17, 1992  
IN PARTIAL FULFILLMENT OF THE REQUIREMENTS FOR THE DEGREE OF  
MASTER OF ARCHITECTURE

## ABSTRACT

This thesis is divided into three distinct yet related parts. The first consists of observations and reflections on some of New York City's many war memorials, ranging from one commemorating the Revolutionary War to one dedicated this past year for the Korean War. What becomes evident within the wide range of memorials, is the degree to which they can be used to gauge the political sentiment and aspirations of previous epochs. In the second section I examine the aircraft carrier USS Intrepid Sea-Air-Space Museum of Patriotism, as a case study of how a contemporary memorial functions within and propagates a particular ideological agenda. This "living" memorial/museum works as a reminder of past threats to nationhood, and of the necessity to retain the state military apparatus to prevent future aggressions. The third section is a design for a war memorial to be located on the Hudson River coast in New York City. The project explores the possibilities for a future memorial, a memorial of resistance. It is intended to create an experience in antithesis to the sentiments of valor, patriotism and militarism glorified in the case study.

iii

THESIS SUPERVISOR: Fernando Domeyko  
TITLE: Lecturer in Architecture



## Acknowledgements

My advisors, Fernando Domeyko, Edward Levine and Ronald Lewcock have consistently pushed me to question and work ever more critically. They have greatly enriched my educational experience at MIT.

Thank you: Saba Al-Suleihi, for constructive comments from Sana' to the present; Michael Bennett, for hanging out, and pushing ink onto a city plan; Prof. Benjamin H. D. Buchloh for the Cold War consultation; Lambert Devoe, for exceptional casting; Murat Germen, for humor and intensity, for actively engaging the project from the design stage to photographing the models, inking and paginating; Robert Hahn, for down to earth structures; Jerry Hart, design talk, science talk and casting; Seong Kwon, for the beautiful site model, and doing it under the pressure; Sowon Kwon, for editing and designing the book, for minutes hours days to nights of inspiration; Gassia Salibian, for casting, smiles; Luke Tan, for genuine tolerance of every interruption (Bought Form); Elliot Yama, for keeping the cats cool in EW; Prof. Wacław Zalewsky, for a last minute blast of practical insight; and Susan and Patricia of the Visual Arts Program, for patience and thoughtfulness.

In New York: The research was made possible with the Tucker Ashworth Fellowship in the Municipal Arts from the Municipal Art Society, and by the generosity of everyone in the MAS office. Nanette Smith of the Art Commission of the City of New York provided invaluable assistance in locating documents in the city archives. My thanks to Professor Bernard Barber for his interest and assistance in my research.

Thanks also to my family for their continued support: my parents, Baba Vera, Dedushka, Babi, Kiera and Mark, and Volodja.

For Sowon

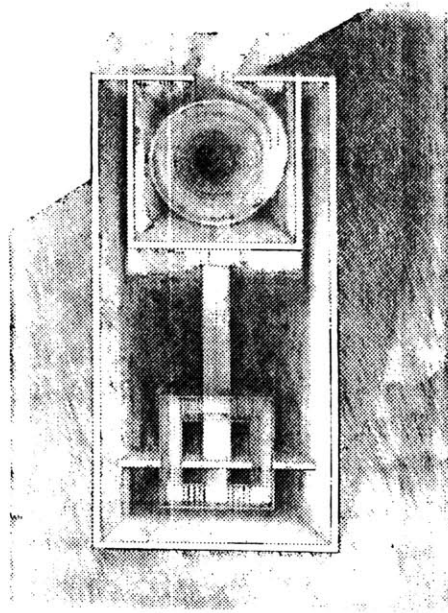

## TABLE OF CONTENTS

	iii	Abstract			
	v	Acknowledgements		Within the Hull	28
	2	The bell and the eagle		Enter the Limbs (cut from a prosthesis)	29
3		Common graves/Private walls		The Unspecified Enemy	30
	5	Wounded Knee		"Victory Park"	31
	6	Good Defeats Evil		End Game	35
	7	Whose Cannon Is It?		Footnotes	37
8		From Flanders Field/Life Insurance		Program (A Labyrinth)	40
	9	A Universal Soldier		Site	41
	11	For Tomorrow's Dead		Could the Belly Contain the Passage of Time	46
	12	Watch tower		Metal Ships Section	52
	17	Warship		Admonishment: A Memorial for Future Wars	54
	19	We		Sites of Memory	56
20		Fortification and Familiarity		Hands Clasped (forming an architecture of worship)	58
	25	Tool or Weapon		Illustrations	71
				Bibliography	72



## The bell and the eagle

The clock tower at the pier head of Pier A in Battery Park at one time pealed ship's bells at each half hour, memorializing the war dead of World War I. It is thought to be the first permanent memorial in the United States to the Great War. Within sight of it is the East Coast Memorial, composed of a bronze eagle and eight monolith granite slabs, with the names of those who lost their lives in the Atlantic Ocean during World War II. The latter memorial catches your attention in the specific, from each word, each name carved into stone. It tells a story open to civic as well as private grief. By contrast, the ship's bells are cryptic mournings to those who know, and to others, possibly only the counting of time or a sound marking for a passing vessel. While one derives its potency from the shared knowledge of a roll call of the dead, the other reverberates in a secret language, embedded in the sound of a waterfront city. The ship's bells may recall the "Lost Generation" of the Great War, an atmosphere of fog, punctured now and again by sound, in memoriam. Could the eagle, laying arrows and branches in the East Coast

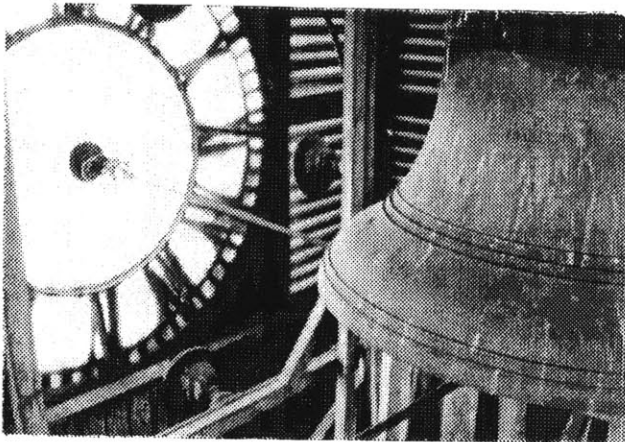

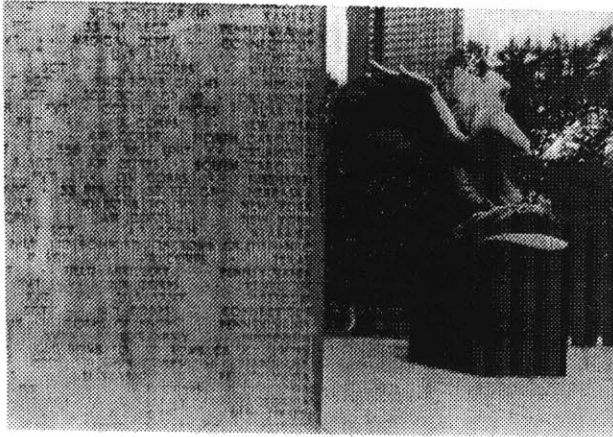

Memorial, with its wings in a vigorous "V," reflect both victory and post-war ambition of the 1950's?

### **Common graves/Private walls**

Two recent Vietnam memorials have used environmental and text based approaches to engage a controversial issue. In Maya Lin's Vietnam Memorial in Washington D.C., the viewer slowly descends, the names marking time, into the common grave of public consciousness. For the New York Vietnam Memorial the design competition guidelines stated that the memorial "should strive to express the contradictory, yet universally shared experiences of war and peace, of danger and relief, of weakness and strength, of isolation and comradeship." Architects Wormser and Fellows, and writer Ferrandino approached this theme by way of a monument that is a wall of words. Public consciousness is revealed by the letters sent during the Vietnam era. At both memorials there is a quality of exchange. Visitors touch the names and words, reading as if in

braille, and leave letters and medals, walking away having shared perhaps a disquieting communion. During the Persian Gulf war Vietnam veterans planted flowers next to the New York Vietnam Memorial in a quiet anti-war protest. After the welcome home parade I found affixed to the memorial a letter addressed to a soldier who had died in Vietnam, and a rubbing made from a name on the National Vietnam Memorial in Washington, D.C. The monuments in this way share stories, linking in death the fate that passed over this nation.

*Dear Cpl. Terry J. Perko,*

*My Dad told me about you. You even saved his life. Thank you very much! He asked me to leave a Marlboro Light, your favorite brand, and a lighter, because you two never were able to have that last cigarette together. If there is an afterlife, I would like to meet you.*

*Gratefully yours,*

*Lance Cpl. M.D.K.*

*1st Marines*

*2nd ReconBattalion*

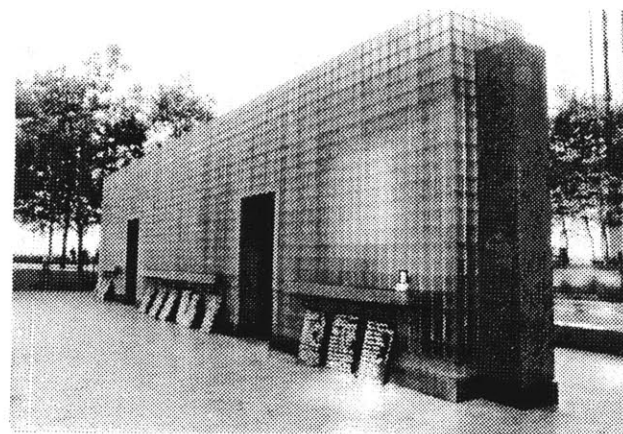

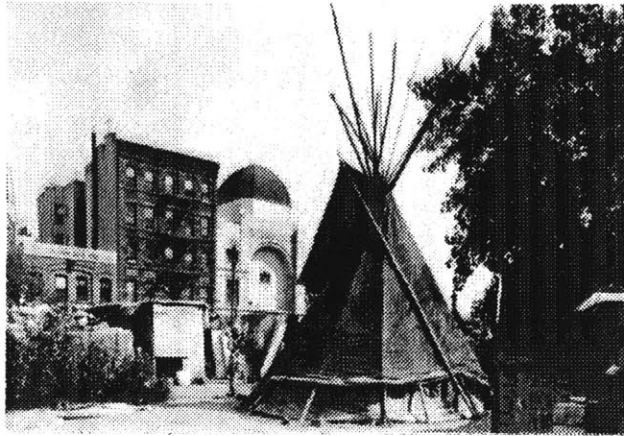

## Wounded Knee

Raised on Thanksgiving Day as a pantheon among the homeless, the tepee was dedicated on December 29, 1990, the centenary of the Wounded Knee Massacre. Constructed from 78 U.S. mail bags and 17 trees, the tepee serves as the lodge of Nick Fracara and Gabriele Schafer, who have formed a group called the Thieves Theatre, and whose purpose is to "embody and articulate the voice of those who are stigmatized, quarantined, and disenfranchised."

A ceremony enters the memorial the moment of its making. A circle is drawn, pulled close, and lines bound and taut. Canvas is stretched and poles dug in, ground is broken and shelter is had within a sunrise and setting. Against the Manhattan skyline it could be gilded and lose itself, a phenomenon of natural history. As it now stands it breathes, in memoriam, but not with the whish around the strike of a drum, a native nation contained within a Department of Indian Affairs, but with a living theater, a theater of thieves. Sounds that enter the tepee are taken on by the images of faces painted within. A woman whistles like a fire truck, a man takes

on the howl of a truck braking. All the while puffs of wind inhale the void inside, and the shadows of junkies are disformed further by the moving canvas. (The security of the tent can easily be ripped by a sharp knife.)

### Good Defeats Evil

As nations present memorials to their citizens, so nations give other nations monuments of peace. The sculptures at the United Nations are in this way national gestures to an international tribunal. *Roots and Ties for Peace* (Yolanda D'Augsburg Ulm, 1983), a gift from the Brazilian government, is an abstract steel sculpture. *Peace* (Antun Augustincic', 1954) donated by Yugoslavia, depicts a heroic equestrienne, carrying an olive branch and globe as symbols of peace. The sculptures donated to the United Nations by the Soviet Union are interesting in their references. *Let Us Beat Our Swords Into Plowshares* (Evgeniy Vuchetish, 1958) is based on a biblical text from Isaiah, and *Good Defeats Evil* (Zurab Tsereteli, 1990) depicts St. George on horseback slaying the

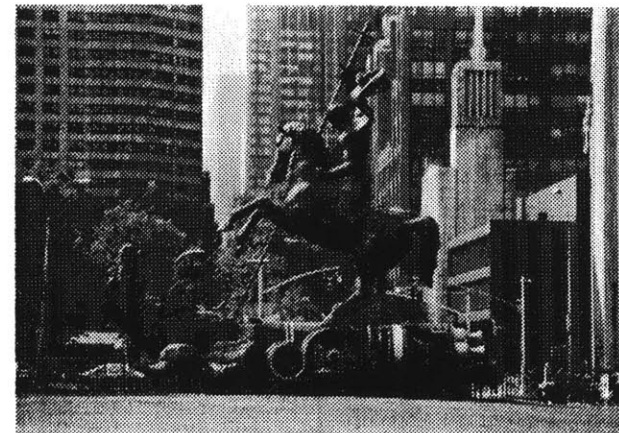

dragon. It is composed of two actual missiles, the Pershing II and a Soviet SS 20. What message is conveyed by the fact that the Soviet Union donated two monuments of Peace, spanning over thirty years, with Judeo-Christian references?

#### **Whose Cannon is it?**

A pre-revolutionary warship cannon is embedded in the grounds of Battery Park and pointed towards the city, towards the Customs House and the Bowling Green beyond. When the cannon was given to the city in 1914 it was placed not far from its present location, but pointed out to sea, in effect re-enacting its original defensive use. The cannon was removed in the 1940's and later relocated to its present location. Was this an oversight or historical correction?

7



## From Flanders Field

*If ye break faith  
with those who died  
We shall not sleep  
though poppies grow  
On Flanders Field*

John McCrae

For those who died so that we may live, echoes strangely with the hoarse coughs and chatter of the Flanders Field doughboy's neighbors, who have established their own trenches between the park benches. Dead boys are seen in the eyes of the crack-eyed, of the youth buried above ground, alive and missing in action under the mottling leaves. Does the faith implied in the inscription have any resonance with the current surroundings of the Flanders Field doughboy?

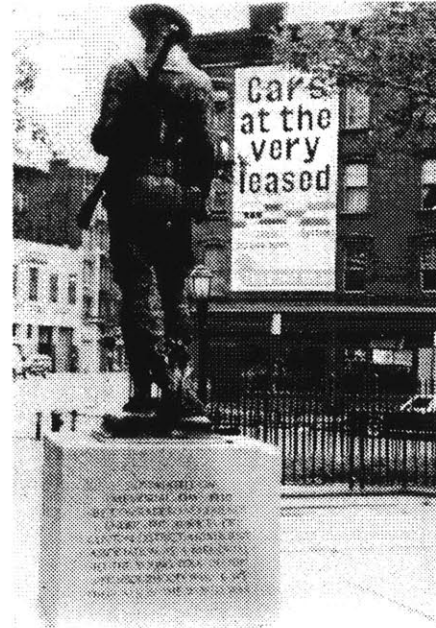

## Life Insurance

Much like village square war memorials, businesses pay tribute to their employees who served their country. The New York Life

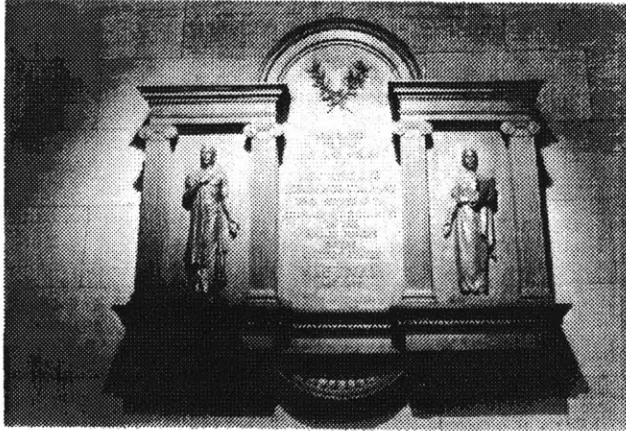

Insurance Company, in their building on Park Avenue, have commemorated the service of their employees in four wars, the First and Second World Wars, the Korean War and the Vietnam War. Most of the memorials in the daily workplace however, seem to go unnoticed, although generally located in public areas. Even the Bloomingdale's war memorial plaque, placed by the main elevators, is lost amidst the panoply of fashion and merchandise.

9



### **A Universal Soldier**

*The Universal Soldier is a fitting monument to the Korean War. It would represent a marine, a soldier, an airman, or a seaman. It could represent a nurse or a corpsman. This could be an American, a Korean, a Briton or any one of the twenty-two nationals that played a part on the United Nations side of the Korean War.*

Thomas W. Evans, Co-Chair of The New York Korean Veterans Memorial Commission. (Courtesy of the Art Commission of the City of New York.)

The Universal Soldier is sculpted as a void to convey not only the idea of loss, of death, but the necessity to represent a multinational, and transcultural constituency. This void is framed by a black granite stele placed on a dias, on which is carved the names of nations and the numbers of dead, wounded, and missing. A shaft of sunlight is cast through the soldier's empty silhouette, illuminating the numbers of dead, the light becoming a flame of a funerary sundial. Does the "Universal Soldier" connote the inevitability of soldiers, and of war? Implicit in "universality" is an all encompassing, limitless quality. As this memorial is of a specific geopolitical perspective, whose universality is it? For instance no mention is made of the dead of North Korea or China, which is understandable in terms of a war memorial, but less so in one that purports to be about a universal man.



## For Tomorrow's Dead

*We too may now choose what memorials we shall raise and entrust to the care of generations unborn in the hope that they shall not appear unworthy in their eyes. In doing so we shall do well to heed the experience of the past and avoid its mistakes.*

"War Memorials," *Bulletin of the Municipal Art Society of New York City*, no.17, 1st Quarter, 1919

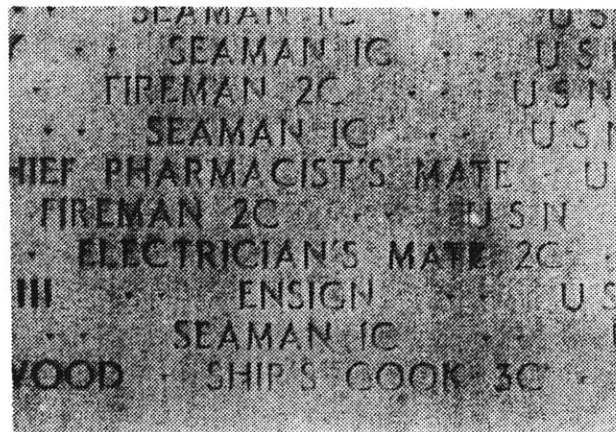

As our monuments are clues to our collective past and our social and political aspirations, so too are contemporary efforts at memorialization a hint at where we may be going. With a war just behind us, victory already commemorated by a "mother of all parades," a question arises as to what kind of monuments will be built to pay tribute to those who served and died. Are memorials which are "victorious" justifiable today, and do they really extend the social and political agenda that built them? Should memorials address not only the irrevocable loss, but also question the political programs that lead to war? These questions are only a few of the difficult

decisions grappled with in the design of a contemporary war memorial. Considering the diversity of the people of New York City, and the complexity of changing and competing social values, it will be necessary to re-examine how these questions about our "collective memory" can be addressed in our new monuments, so when finally built, they work as testimonials for our time.

### **Watch tower**

A watch should be sent up the tower to spot the hyper-mediated influence that a distant conflict can have on our collective reasoning. All the poppies of our backyard field are deadened. As the popular media of television and news magazines become the barometers to test our cohesiveness, we become voyeurs of power. The looking glass is backwards.

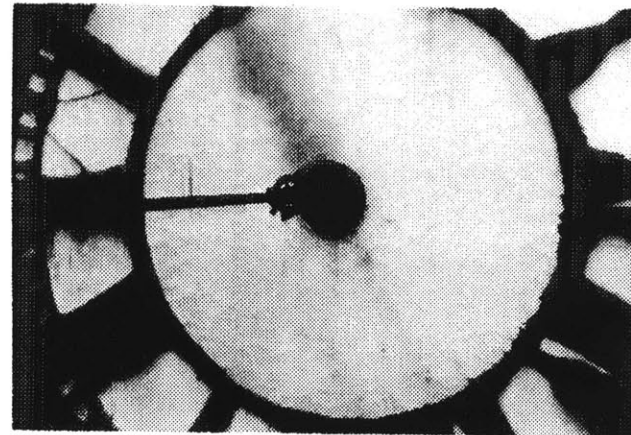

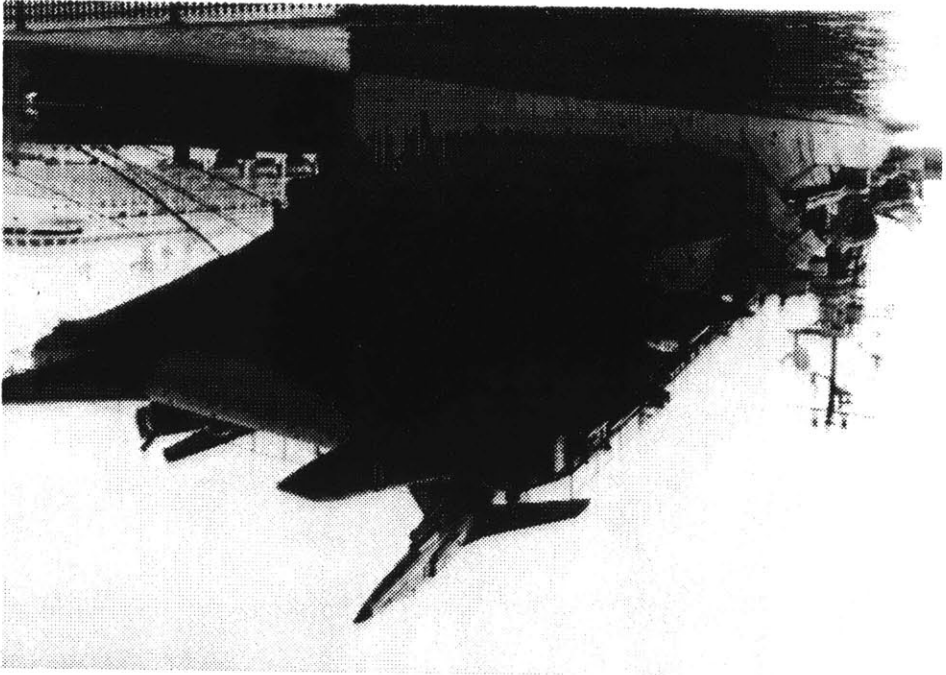

**VICTORY IN WAR IS  
APPARENT TO ALL, BUT  
THE SCIENCE OF ENSURING  
VICTORY IS A MYSTERIOUS  
SECRET, GENERALLY  
UNKNOWN.**

-Li Quan in *The Art of War*



In addition to paying tribute to those who served and died in war, war memorials can also function as built reminders of the military agenda for which those memorialized died. Through references to the sacrifices made in the name of duty, national identity, and patriotism, monuments of war and peace can prolong that agenda. They can, in short, be seen as attempts to grasp at that mysterious secret of ensuring victory within the field of representation. That victory is also over the minds at home. Having established a victory militarily, and in the process brought to the nation death and grief, there is the necessity both for consolation, as well as for the preservation and perpetuation of the state apparatus which engaged in war. Memorials can at times be built ideology, revealing a particular moment in the sentiment of a nation, state and city, and over time becoming a measure to gauge the social and political aspirations of previous epochs.

Their social and political readings can however change. Some monuments are merely forgotten, and others become rallying grounds for new causes. What are the factors that govern the conception and construction of a war memorial? How are the interests of a small group or individual served in the seemingly inherent national and patriotic nature of war memorials? The memorial examined in this section is the aircraft carrier USS Intrepid, which opened as a museum in 1983. Here the national military agenda is no longer only a subtext. This "living memorial" is the brainchild of one individual and is in fact called "The Museum of Patriotism."

## WARSHIP

*...step back into history... Climb aboard the aircraft carrier USS Intrepid and retrace the footsteps of history.*

-promotional brochure for The Intrepid Museum

*Today, Intrepid's battleship consort Iowa has been recommissioned as a formidable fighting machine adding depth and flexibility to the US Navy's capacity to respond to challenge in the present-day contest for mastery of the oceans. In this contest, we must keep the sea lanes open in the face of threat, or even strong free nations can succumb to creeping or avalanching aggression, leaving the US potentially isolated in a conquered world...Today, Intrepid serves a role fully as Iowa's. She serves as a remarkable museum exhibit.*

-advertisement for the Navy League of the United States, in their journal *Sea Power*

The aircraft carrier USS Intrepid: Sea-Air-Space Museum and The Museum of Patriotism, is located on the Hudson River and 46th street in New York City. Although the ship itself is a National Historic Landmark, The Intrepid Museum Foundation is not part of the U.S. Navy, or any branch of the Federal government. Founded by Elizabeth and Zachary Fisher, "two very dedicated,

patriotic New Yorkers who believe that 'freedom is never free'," the ship functions today in the new guise of a non-profit museological organization.<sup>1</sup> In brochures publicizing the museum, the Intrepid's role as a national monument and educational institution is emphasized and to some extent legitimized by invoking more famous (historically and commercially) moments and sites from American history. The Intrepid, with its "hallowed decks" is

*... comparable to the national historic sites at Gettysburg and Valley Forge... Today, the Intrepid no longer makes history. Instead she is the storyteller for America's history and technology.*<sup>2</sup>

An attempt is made here to inscribe the Intrepid into a lineage of pivotal sites and events in the official canons of American history. The site, as it is compared to other places of national pilgrimage, Gettysburg for instance, is linked to national patriotism. As a visitor then, foreign or otherwise, one participates in this pilgrimage. In contrast to Valley Forge or Gettysburg however, the Intrepid enters American history not for where it is and what took place there but for where it has been, what it did there (the legacy can continue abroad), and how it can teach us.<sup>3</sup> There is also a conflation of technological history with military history. Science made our military history possible and we need this ship to tell us about it. It is from here that a rationale and justification for the social acceptance of the military industrial

complex can be simultaneously produced and reproduced. A hard sell.

## WE

*Monuments are the expression of man's highest cultural needs. They have to satisfy the eternal demand of the people for translation of their collective force into symbols. The most vital monuments are those which express the feeling and thinking of this collective force--the people.*

*Every bygone period which shaped a real cultural life had the power and the capacity to create these symbols. Monuments are, therefore, only possible in periods in which a unifying consciousness and unifying culture exists. Periods which exist for the moment have been unable to create lasting monuments.*

-Jose Luis Sert, Fernand Leger and Sigfried Giedion, "Nine Points on Monumentality"

*As Marx said, every child knows that a social formation which did not reproduce the conditions of production at the same time as it was produced would not last a year.*

-Louis Althusser, *Essays on Ideology*

The Intrepid Museum of Patriotism presents the cohesiveness of a "we," with a sophisticated use of technology and media, both

presumably prerequisites for an enduring contemporary monument. This "living memorial" is firmly of its time, combining commercial awareness with grounded patriotism, that umbrella of a "unifying consciousness." The "we" prescribed by the Intrepid is the role we take once we enter it as a visitor, engaging it as a cultural site. As a recreational site, a place to "kill time," the warship becomes both playground and textbook. It allows you to explore, wander, *learn*. But that education is one of apprehension, of warning. Our perceived vulnerability and the necessity for military machinery seem to go hand in hand. The Intrepid operates both within the *mahnmal* and *denkmal* framework, as both a monument and a memorial. As a military monument it expresses a warning to the nation and to the world, of both the necessity of strength and preparedness, and as a memorial to those who died and served to perpetuate that strength, that "freedom which this country now enjoys."

20

## FORTIFICATION AND FAMILIARITY

*... surviving fortifications (even half surviving ones) have by now become monstrous monuments prompting armies of tourists to assault them.*

-Robert Harbison, *The Built, the Unbuilt, and the Unbuildable*

From the street the USS Intrepid presents a formidable, if not frightening facade, particularly at night when it is lit from below the bow. The flight deck several stories above bristles with planes and armaments. One plane is placed in the take-off position, facing the city. In its monumentality the Intrepid, as a fortification, operates as a symbol of the nation's fortitude. The fortification as a physical entity can outlive its intended use, yet retain elements of symbolic value.

What the Intrepid presents on the outside is partially mediated, yet also accentuated, by the exhibits within. As one enters there is an almost carnival-like atmosphere to the exhibit halls; voices of several different video narrations, often with accompanying sounds of battle, compete for your ear, while all around you, hanging from the ceiling and stretching across the hanger bays are military craft of all types, each with their history and statistics displayed on easy to read storyboards. These descriptions, performing the specific educational role of the monument, also begin to couch the war machine into a familiarity, each "significant" history and statistic reveals to you, the general public, the workings of the machine. This steady demystification of the technology also works inversely, obfuscating the first and foremost fact, the killing. We as "initiates," as tourists, participate in that killing, consuming the technical data to accompany the images, and soon become adept at recognizing the machines for their particular specifications.



**Arithmetic, the number, has always had a decisive role in the State apparatus... Thus the number has always served to gain mastery over matter, to control its variations and movements, in other words, to submit them to the spatiotemporal framework of the State--either the imperial spatium, or the modern extensio.**

**man-horse-bow, 1x1x1**

**Chariot, two horses and two men "2x1x2=1"**

-Gilles Deleuze and Felix Guattari,  
*A Thousand Plateaus*

In addition to the historical anecdotes of its exploits, the specifications of the USS Intrepid are given in exactitude, which goes as well for practically everything exhibited on the Intrepid. From the Information/Map brochure, we are told that the Intrepid is:

Built: Newport News Shipbuilding and Drydock Co.  
VA. Completed August 16, 1943

Displacement: 33,000 tons standard  
42,000 tons full load

Dimensions: Length overall: 898 ft.  
Width, hull: 103 ft, flight deck: 152 ft.  
Draft: 31 ft. full load

Powerplant: Eight 600 psi boilers  
Four steam turbines, 150,000 shp, 4 shafts

Speed: 30+ plus

Aircraft: World War Two: 103  
As CVA: 70  
As CVS: 47

Armament: Four 5/38 AA

Complement: 1,615 plus 800 Air Wing as CVS

Its location in the city is likewise precisely documented, provided in the cross hairs of the minute: 2 minutes northwest of the Lincoln Tunnel. 2 minutes north of the Javits Convention Center. 10 minutes due south of the George Washington Bridge. 9 minutes northwest of the Empire State Building. 12 minutes due north of the World Trade Center. The warship thus becomes easily placed within the cultural geography of the city. It also quantifies and abstracts its role as an instrument of death: "Her air wing destroyed 650 enemy planes on the ground and in the air. Some 289 enemy ships were sunk or damaged by

Intrepid's aircraft..." and [it] "... served three tours of duty in Vietnam, notably hitting significant targets while deployed in the Gulf of Tonkin."<sup>4</sup> This role is later absorbed, becoming testimony to the "technological excellence and human courage which are the American heritage."<sup>5</sup> The killing machine thus becomes a necessary instrument in the American Dream: "The Intrepid has become a monument to American know how and spirit."<sup>6</sup> In the end it is the *numerical elements of a war machine* which are of interest, everything else, the politics and killing, are laid to the side.

25

## TOOL OR WEAPON

*A distinction can always be made between weapons and tools on the basis of their usage (destroying people or producing goods). But although this extrinsic distinction explains certain secondary adaptations of a technical object, it does not preclude a general convertibility between the two groups, to the extent that it seems very difficult to propose an intrinsic difference between weapons and tools.*

-Deleuze and Guattari

The warship as science museum transforms its military role into an exhibit of technological patriotism, whose primary role, that of war, is subsumed into an unfortunate necessity. The implication

is that the technological achievements of the war machine is a product of man's desire of advancement. For instance the Intrepid will allow you to "look back at the fledging birth of aviation as the 20th century dawns and pass through Intrepid's time machine into the space age..."<sup>7</sup> A threat, past and present, is finally transferred to the scientific unknown. Implied in this transformation, from war machine to scientific discovery, is the need for the continuation of the state war apparatus. It relies, ultimately, on the fear of the unknown.

The military by definition must constantly reaffirm its usefulness, pointing towards perceived and unknown threats, and the proven historical necessity of "being prepared." The military instrument turned "civilian" monument either abandons its ties completely to its past, or like the Intrepid, reaffirms its necessity and ideology. Within the need for legitimization, both as an educational instrument and "former" war machine, it both reassesses its original function and obfuscates it. Its role as a warship, a war machine, is mystified, becoming not simply an instrument to destroy, but a builder, a builder of peace and an architect of ideology. In the displays of technological achievements, and therefore "progress", the warship USS Intrepid becomes a player in the "development" (patriotic and technological) of a nation. Because that progress is tied to science, the warship then supposedly participates in no less than the evolution of man. Within this logic, not only has it spurred a nation's progress, but in doing so has benefited mankind.



## WITHIN THE HULL

The smell of steel and salt air stills, for a moment, thought of any real mortal danger, and then the exhibits start, calling you school boy like to attention. One can learn, learn about machines and men. The Hanger Deck of the carrier is divided into four major sections, or Halls: Navy Hall, for the modern Navy; Intrepid Hall for World War II; Pioneer Hall for achievements from 1890-1941; and Technologies Hall, exhibiting 20th Century Science and Technology. The hull, truncated into time, time into technology, and technology into preservation: of itself, and like an animal, from itself. Starting with the most volatile, and ending with the purring domesticity. War movies in the bow, automated canteen food in the stern. One is, naturally to move from the bow to the stern, and in this movement there may be, however slight, the realization that the jets and wings and bullets, somehow evolve into the kindler, gentler offspring, a domesticated offspring. Other exhibitions relate either specifically to the Intrepid or have visiting, thematic exhibitions, the Battle of Britain for example (The whole world stands by us, sing along with us now). Emphasis is placed on a historical significance; first, biggest, highest, fastest, etc. For instance it is the site of the "Largest collection of Congressional Medals of Honor," contained within its own "Hall," which also happens to be the "National Headquarters for the Congressional Medal of Honor Society." A painting in this room depicts a civil war era soldier, holding an

American flag, juxtaposed with soldiers from the Second World War, with today's officers and soldiers, and finally, with the Statue of Liberty rising from the earth behind them. This painting carries not only the idea of a lineage, a tradition, but the appropriation of time and symbols, collapsed under the free weight of patriotism.

In the bow of the carrier one can watch on a giant screen the heroic action, like athletes and gladiators, the sailors and airmen of the United States Armed Forces. Recently there was a full array of Persian Gulf War scenes, with an emphasis, of course, placed upon the effectiveness of weaponry, and the great skill the fighting men have to attain to handle these machines. Hundreds, thousands of man hours spent wielding the machines to attain the perfect killing posture comes from an education spurred by myths, modern myths of GI Joes and God Bless America, all over the world. At the end of the cinema program one leaves, naturally, vivified, blood as patriotism runs warm under one's skin. It is, technologically speaking, the smell of the kill, an architecture of supreme, beautiful, anarchy.

29

### **ENTER THE LIMBS (cut from a prosthesis)**

The device that is implemented for destruction is placed as an instrument ready, the cure. The machines are no longer, once you have been culled into the swing of things, things of death, but devices to prevent death, a collective death insurance. In the

end, the instrument is innocent. It is not science, or technology that is the aggressor, but man, other men, the fascist, the communists, the enemy, preparing always a "creeping or avalanching aggression." The warship like the Trojan Horse operates as a monstrous prosthetic device, the body now enters (the time machine) the armour, (the war machine) to provide speed and destruction to an enemy, to the unknown frontiers. The tourist enters the exoskeleton becoming eventually inoculated, seduced by the armature.

## **THE UNSPECIFIED ENEMY**

Implicit in a science museum is the role of science pursuing, and surpassing, the unknown. Therefore it is the unknown, rather than the known that is the compelling, and underlying element in the museum. The emphasis on the measurable, the statistics of each object, is in contrast to that which has yet to be achieved, what has yet to be surpassed. The warship/monument/memorial as a museum of SEA-AIR-SPACE already colors, red, the astronomical sky; the "conquering" of space is presented in the same frame as the victory over one's enemies. Here the "enemy" is simply the unknown, where science stands guard to pursue space to the limits of knowledge. Like the war machine within a State apparatus, constantly reaffirming in peace time the necessity for its perpetuation, the pursuit of space technology is

placed against the unknown, which for the war apparatus must, by definition, be the enemy.<sup>8</sup>

## "VICTORY PARK"

*Now any commerce has a space-taming function; selling, buying, exchanging--it is by these simple gestures that men truly dominate the wildest sites, the most sacred constructions... for such commerce testifies to a kind of affectionate familiarity with regard to a monument whose singularity no longer intimidates...*

-Roland Barthes, *The Eiffel Tower*

31

This past summer on the pier adjacent to the Intrepid a fair was set up, its banner made up in red, white and blue: Victory Park. As a monument the Intrepid serves as a magnet, with its metallic hulk, drawing any form and size of patriotism to its quarter. Even though unrelated as business entities, the warship and the ferris wheel formed an image of the same "ride," the same game. The killing and the celebration, the victory and the diligent machine, side by side, one propagating by education, a moral didacticism, the other by release, water slides, a urination of appeasement.

The fact that the fair was placed next door to the Intrepid does not pose any philosophical problems within the context of the Intrepid's own site, as there is already a small congregation of

monuments/memorials/gift shop. This area, known as the Armed Forces Plaza, was "dedicated by Zachary and Elizabeth M. Fisher in tribute to all those who served in the United States Armed Services." The brochure tells us that the "park/plaza is a lovely place to relax and enjoy the day, as well as remember those who have fallen and those who have served": amidst a M-60 Patton battle tank, a M-42 Duster self propelled gun, and between them a section of the Berlin wall, with an inscription of graffiti-like words: "THE WALL." It is a curious omission on the brochure that the wall is not mentioned, although it is placed there on the plan, and in a photograph. Is the wall authentic?

Also in the plaza is a sculpture which pays tribute to those who continue to do their patriotic duty. Entitled "Anchors Aweigh," it depicts a sailor waving, carrying his sea bag over his shoulder. The pedestal inscription reads: *The American Blue Jacket/ protecting the seven seas /always in "Harms Way"/our first line of defence/our finest ambassadors.* This statue, with its inscription (by Zachary Fisher) and friendly wave, is inviting (hello/goodbye), it pays tribute, it remembers, yet it admonishes. The sculptor, Felix de Weldon has said that the sailor is not unhappy waving goodbye to his girl, because he knows in the next port another girl waits for him(!) Placed in New York City directly across Manhattan Island from the United Nations, this is an American gesture towards international diplomacy.





## END GAME

*There is a schizophrenic taste for the tool that moves it (the war machine) away from work and toward free action, a schizophrenic taste for the weapon that turns it into a means for peace, for obtaining peace. A counterattack and a resistance simultaneously. Everything is ambiguous.*

-Deleuze and Guattari

Although I did not demonstrate how these memorials fit into a general framework of memorialization and monumentalization, I hope my reflections and references bring about a sensibility in terms of how a memorial is so easily manipulated, and that this is more than likely to propagate the dominant ideological structure of a nation, even though the conception and construction of a memorial may be driven by an individual. What seems evident from the recent memorials, the New York Korean War Veterans Memorial (1991), The American Merchant Mariner's Memorial (1991), and the Intrepid, is that a war memorial as an element in the civic and national landscape is used in a greater ideological setting. Imbedded within the *mahnmal* reading is sharp admonishment, these are lessons towards a future in which militarism becomes indistinguishable from a sense of justice and progress. Although the argument runs towards a decreased tension and militarism with the close of the Cold War, I believe

that the role of memorials and monuments become even more important, because they do remind us of former aggressors and the necessity of retaining the war machine. The Intrepid is possibly a model for future monuments. Ostensibly war machines could be placed on exhibit as archaic devices of diplomacy and control. I believe however they propogate the myth of the necessity of war and as modern monuments, are frightening yardsticks of the sentiment of the nation at this time.

---

<sup>1</sup> The USS Intrepid is one of several warship museums berthed in a city. There are for example the Battleship Aurora in Leningrad, the USS Constitution in Boston, and the USS Yorktown in Charlestown, South Carolina.

<sup>2</sup> *Public information brochure*, Intrepid Sea-Air-Space Museum.

<sup>3</sup> It is interesting that the revolutionary and civil wars are cited. The two sites mark moments not only when America was at war on American soil but also when its very identity as a nation was in jeopardy. Could this attempt at inscription into this particular lineage also be signalling a similar crisis in the present?

<sup>4</sup> *Press release*, "History of the Intrepid", Intrepid Sea-Air-Space Museum, undated, p.2.

<sup>5</sup> *Ibid.*, p.3.

<sup>6</sup> *Ibid.*

<sup>7</sup> Intrepid promotional brochure

<sup>8</sup> A parallel can be found at the Astronauts Memorial at Cape Canaveral, Florida, where the inscription on the tablet, facing the United States flag, reads: *Whenever mankind has sought to conquer new frontiers there has been those who have given their lives for the cause. This Astronauts Memorial, dedicated May 9, 1991, is a tribute to America's men and women who have made the ultimate sacrifice believing the conquest of space is worth the risk of life.* (emphasis mine).

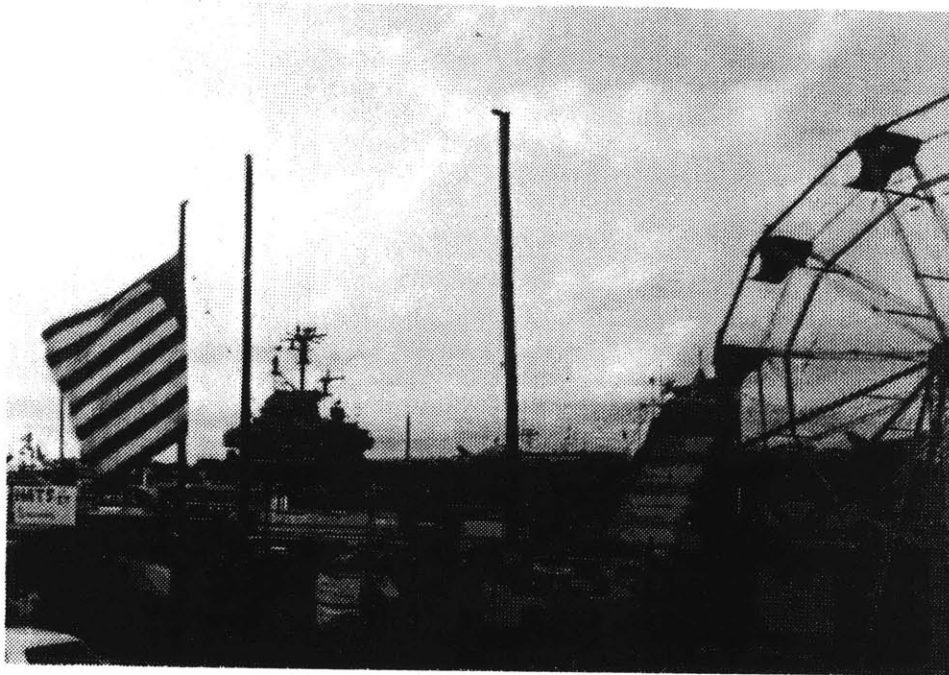



## **PROGRAM (A LABYRINTH)**

Without identifying particular traits of programmatic necessity, those movements and functional stations of a building's working parts, we (Domeyko, Levine, Lewcock and myself) at the first thesis meeting, determined that the program of the thesis was to identify specific experiences which would drive the design. So it remains to the end that the program is those experiences that one may, or may not, identify with after travelling through the structure. What remains clear is that the experience finally is not liberating, nor is it necessarily reflective. No sign of iconography is evident. Words of admonishment or consolation, even in the seemingly innocuous scribe of a name in memorium is absent. The quality is that of absence, the irreducibility of mortality, a blamelessness.

40

The lake, fire, and perseverance. The walls occupy the never ending, the ramp the tortuous, the underwater passage, the nave. Emerging one is placed upon a palm: is one on trial, or a charlatan of hope?

## SITE

In lower Manhattan there are close to a dozen war memorials, all less than a 10 minute walk from the proposed site. They are all located on or near the water's edge, and follow the course of the coast line, creating what could be termed a "memorial arc." They also form an inverse arc about the Statue of Liberty, which is used as a focal point of several of the memorials. Just north of my proposed site and adjacent to South Park *The Living Memorial for the Holocaust: Jewish Heritage Museum* is in the planning stages. And although never realized, two other war memorials, one designed by Louis Kahn, were proposed for nearby locations. Given these conditions and precedents, it appears entirely plausible that the memorial building tradition will continue in this area of New York.

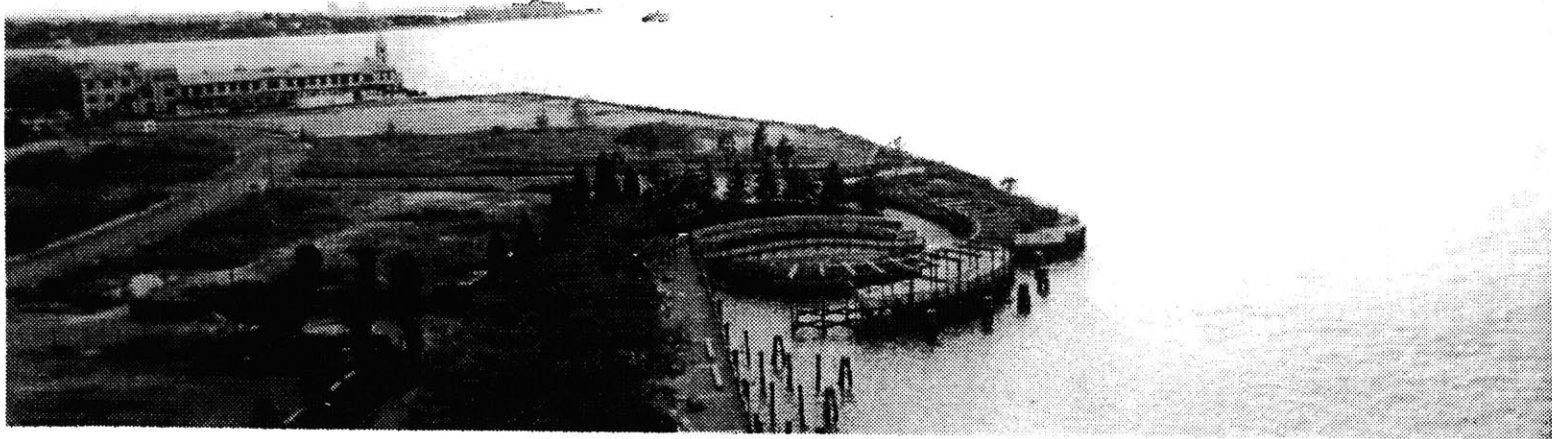

The site for my project is at one end of the 180 degree "memorial arc" on the Hudson River, the other end being the New York Vietnam Veterans Memorial on the East River. While the design process followed an unpredictable route, there were some observations and concerns which clearly directed the project from the beginning. The conditions of the "natural" geography are set up by the cultural reading. The river vista is not only an expanse of water, the edge of a city, but contains a national icon, the Statue of Liberty. Another consideration is the relationship of the adjacent buildings, which form a wall around the site, but are presently situated so that they neither cast shadows nor create a definite sense of enclosure. These buildings form a partial cordon about the site, contributing to the perception that the field is larger than its actual dimensions. The eye travels a distance and stops. An upward glance carries for a moment the rising towers of the World Trade Center, then is carried out beyond the city. Presently the site is a grassy field, used on occasion by a travelling circus, rodeo, or outdoor concerts. It is in fact one of the few clear areas in Manhattan; neither built nor vegetative matter exists in any substantial form. Retaining this field with an uninterrupted vista, both towards the river and the city, remained an important factor in designing the memorial. Keeping this in mind, the memorial could not be monumental in terms of the plain. The horizontality would have to be preserved.

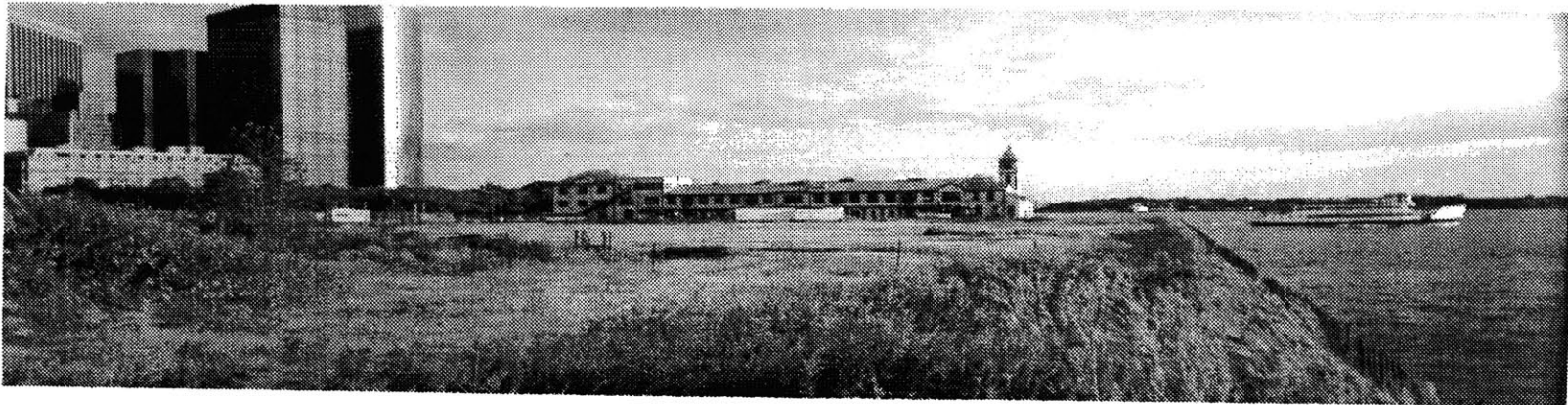

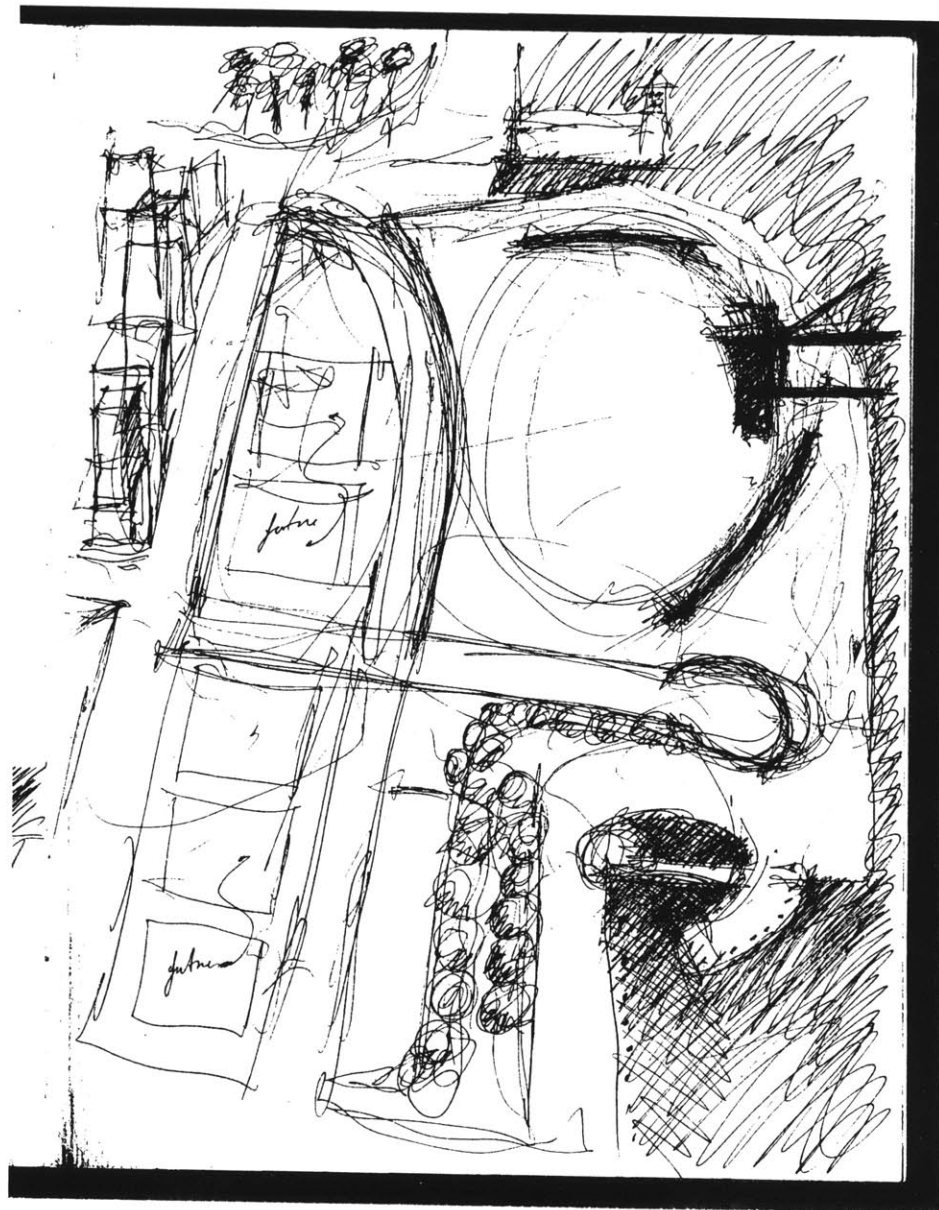

What a site connotes is the idea of a collective law, the "context" that comes before you and yet yields to one's intervention. Here at the tip of Manhattan on land fill, the collective recycled is, sifted and seeded, a new city, burying maritime trade and commerce, the shift of trash with every new tide now held in place, retaining walls and their dead men, lying parallel and perpendicular to the stretch of the island's length.

Readings of the site are developed from the physical characteristics of the earth, the trash of land fill, butted and joined to previous land fills, pushing further the island into the river. A new grid comes off of the city's: zones created; residential, light & heavy commercial, park and cultural lands. All the while the slow disintegration of waste, finer particles of memory opening potentials. The geographical properties transform the cultural landscape, as cultural icons demarcate territory, alluding to national, technological and moral supremacy. In one direction we see the twin towers of the WORLD Trade Center, turn 360 degrees, the arm of Liberty.

the image of some passing by as if in formation with the spoils. Book plates pressed on all together like shelves. The tide here faces the centrifuge below.

Towards a ne/paris krajolov

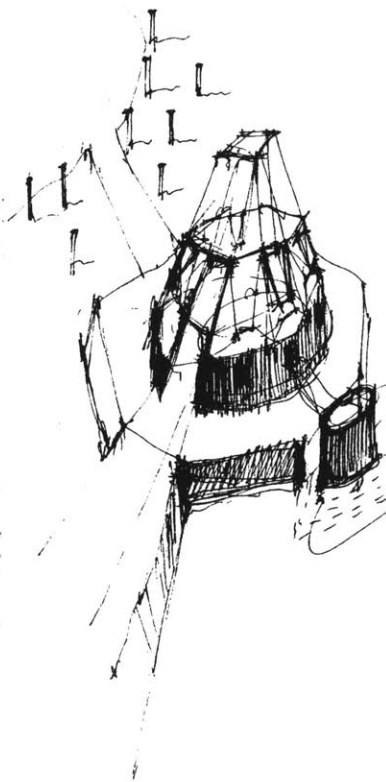

New building, now a family life, with part holes of air passing through

Centrifugal slide/pit

its brown a cut in earth where water in forms ducts the edge with a line

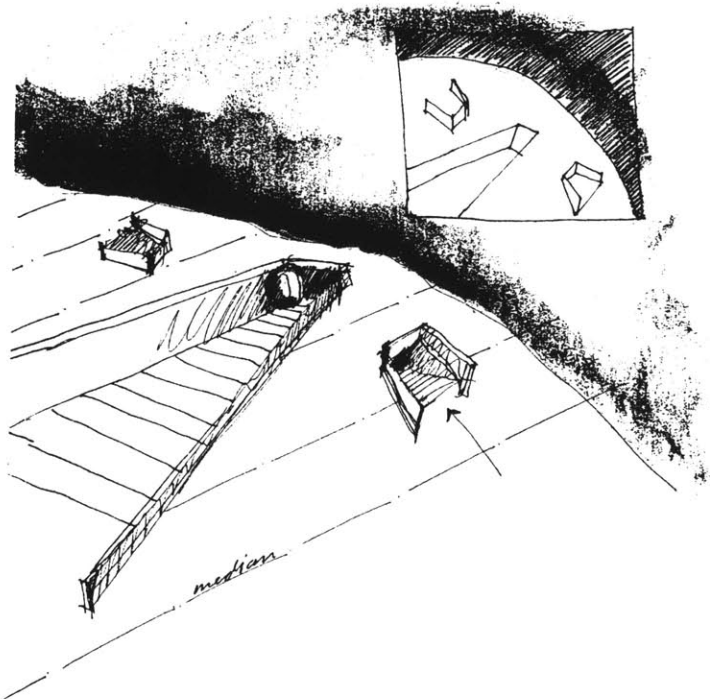

medium

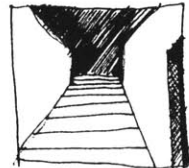
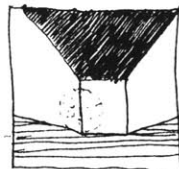
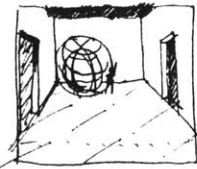

## **COULD THE BELLY CONTAIN THE PASSAGE OF TIME**

The Site could be in a biblical landscape, with the wounds, thorns and calling cards of man hunters, or within the cry for God in a holy war, all for one, or nothing will remain but a wasteland. The site could be the belly of a wooden horse, swaying ship like with the reek of soldiers waiting for the gift to be received, that of a war machine. I am taking as my cue the grinding of logic behind a violence committed with political forthrightness and solidified with a populace stirred with patriotism. Kings, knights, bishops and prime ministers have the power of mouth to mobilize thousands towards and against each other. Fronts move forward, an architecture crumbles. Soon another will be built, and within the rebuilding there occurs the gift horse, a necessity. Dues are made to the agency which proliferated the destruction. The site then is abandoned, a wreck, a ship now held up in mud, thieves displaying their wares.

must mention Trevi fountain - Rome.  
 bldg stone to rock (C)  
 Pantheon -

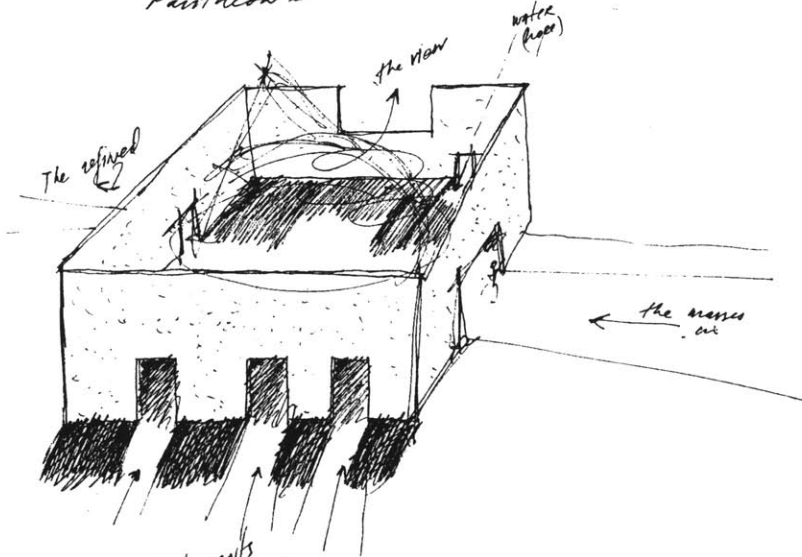

47

instruments  
 of progression  
 wisdom's  
 authority

• In idea of entrance - doors  
 of authority, public, private.



records as slabs - the  
 recorded information.  
 • cut on hand saw.

15 X 91

A War Memorial  
 15 X 91

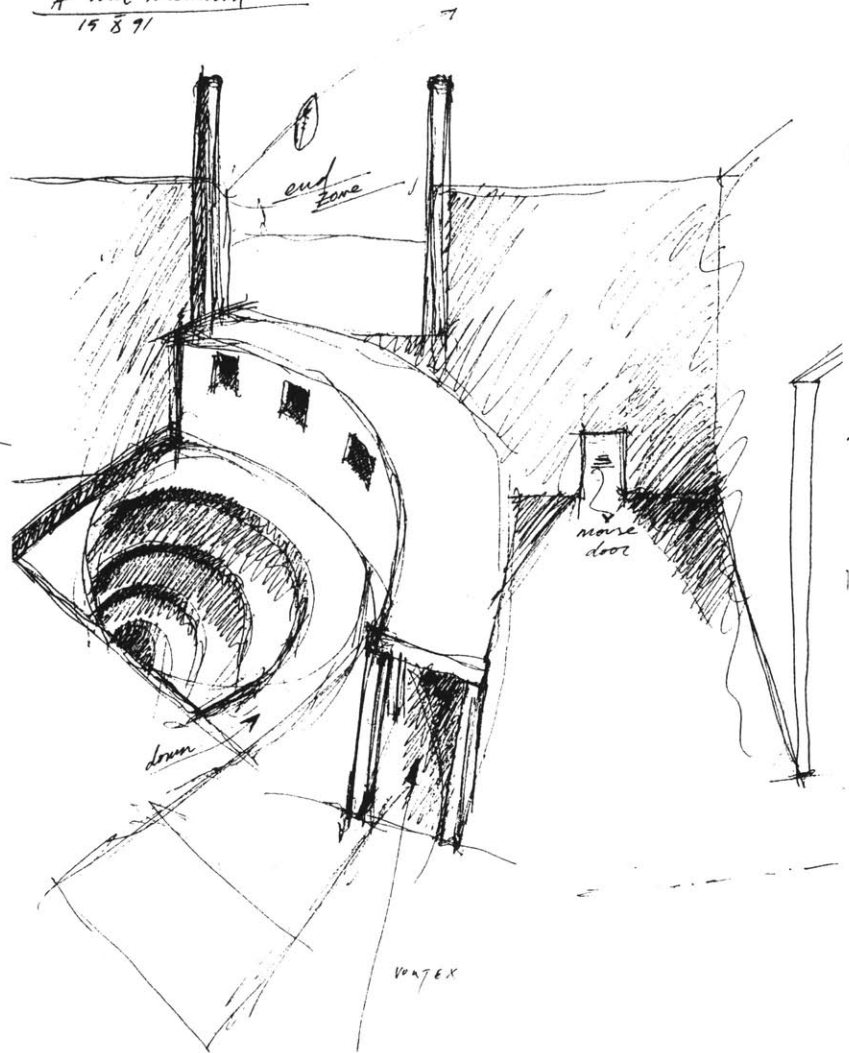

VORTEX

Again: the walls are not liberating. The passage one takes, twisting down, a screw driving into earth, disappears in water. One is directed, if willing, towards a ramp, sloping down, with shafts of oblique light reaching the seemingly subterranean passage. At the distant end there is a clearer light, reflected on falling water. It should be apparent, even to those with a poor sense of orientation, that one is below the river, contained now within the memorial, a giant crypt. Emerging, one is placed on a precipice. On four sides the walls cant inwards, towards you, while the river's water plunges down, masking the distance between the concrete, the tangible, and the river's desire to rise, to reach one's precipice. One may move either left or right, up and through the inward canted wall, more steps, to emerge finally within the bowels of the structure. Here the water lies still, barely reaching the low wall that contains you. The roar of the city is indistinguishable from the sound of the water dropping into the precipice, beyond the wall through which one has just passed. Through the murky water one recognizes the journey taken, the shaft reaching up, back towards the city. At night, the still surface of the water is broken with rings of light.

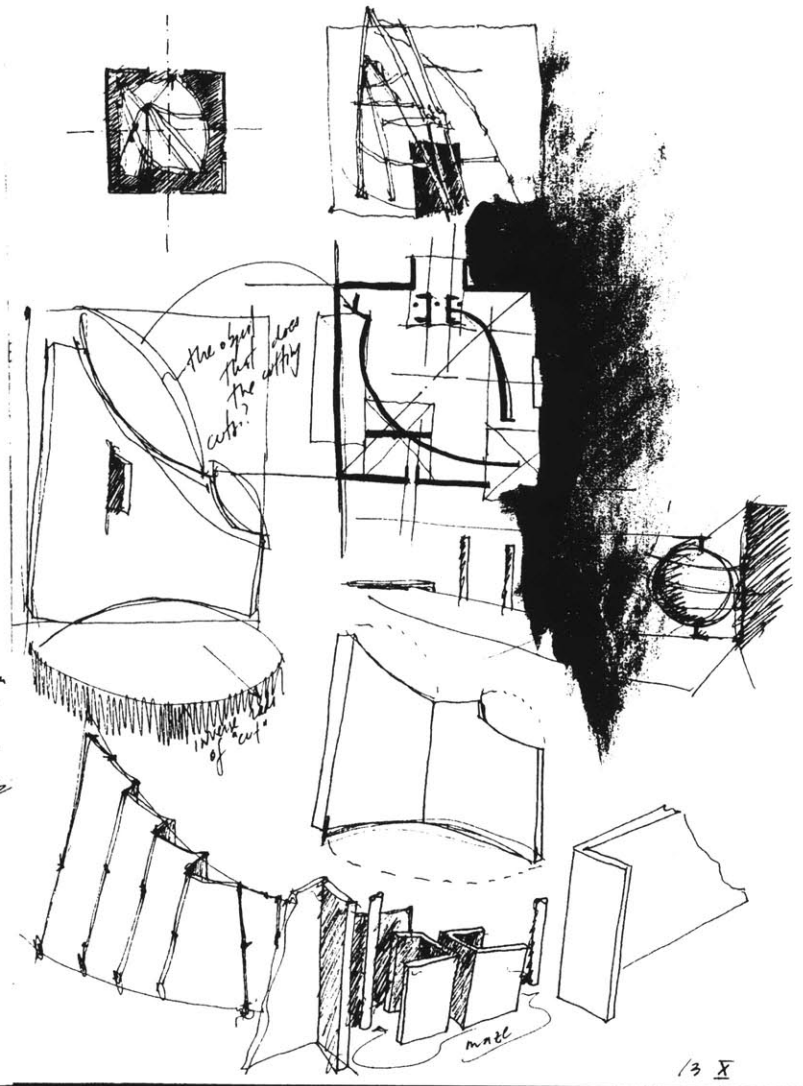
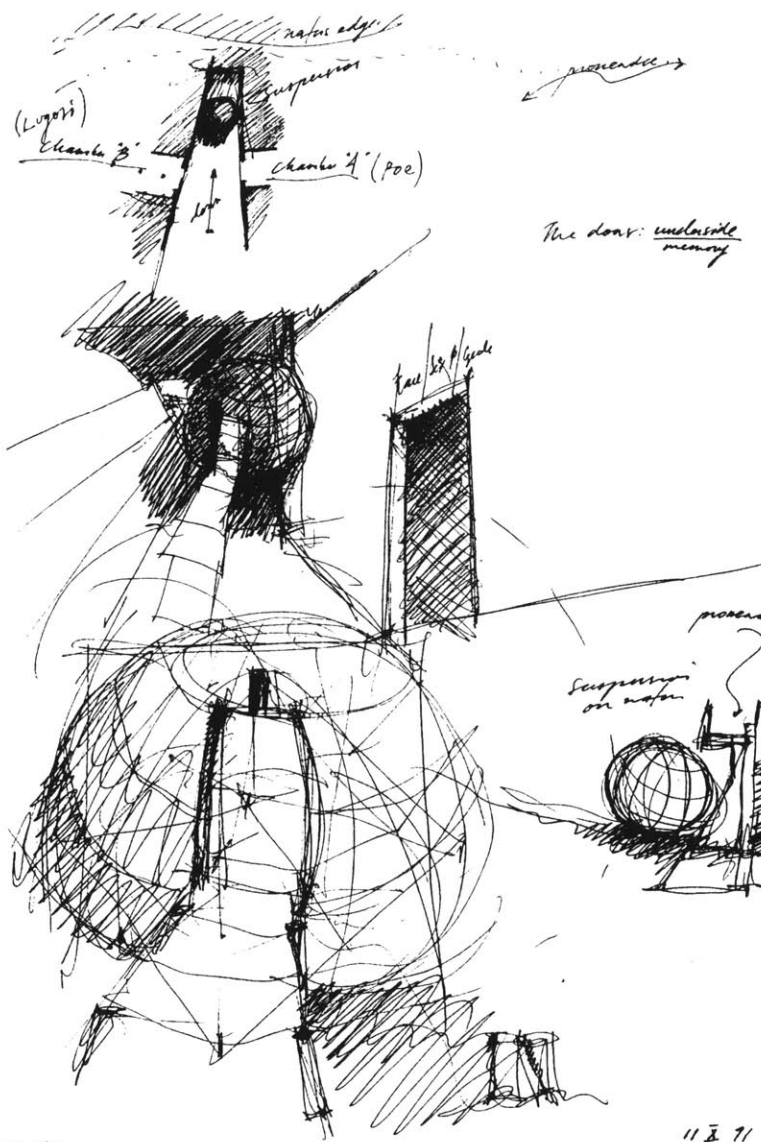

Indomitable walls, a cistern, churning, to finally be the orator to a silent architecture. Its role as inquisitor is unmistakable, yet it is the occupant that by nature becomes the inquisitor: why, why such monstrosity?

The access is through a labyrinth, a self burial between the walls. (Outside we join clubs, universities, parties, and eventually participate silently, by the radio or television, to the diligent killings of nations and peoples, under God.) Inside nature pulls, weeping with high water, and dry under the weak pull of the moon. Nature is mocked, the mechanical breath held, timed, released, timed, the walls providing the armature for man's control. The mechanical lung ticking, ticking according to an arbitrary day and night, filling the tank, sucking from the pool at the bottom of the precipice, the water moving from each container, a river's force redirected, misdirected. Given a failure of the clock, the mechanical apparatus held still, the water will rise to attain equilibrium with the surrounding river. The walls which provided the bulwark against time and nature now stand as the lost strivings of another era, the water slowly reducing the monstrosity to ruin.

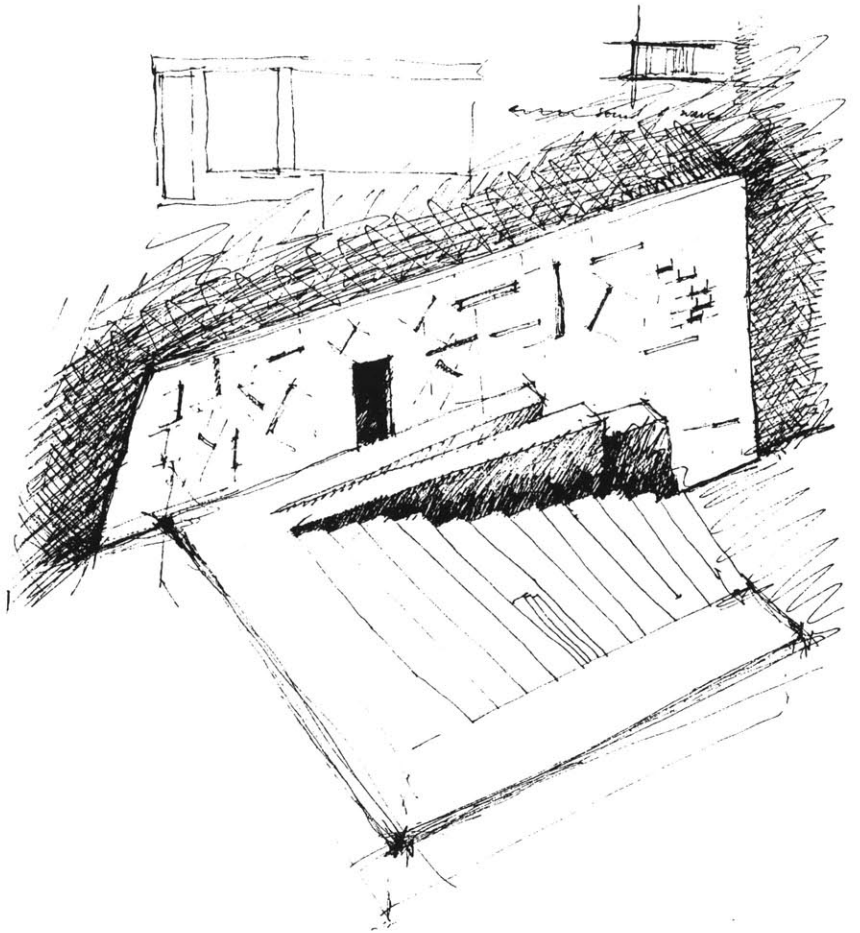
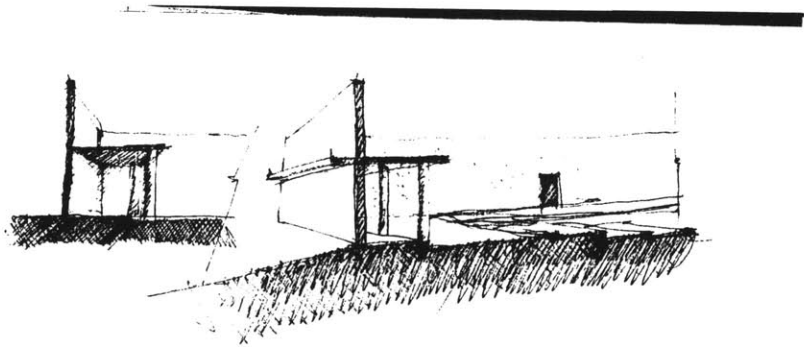

51

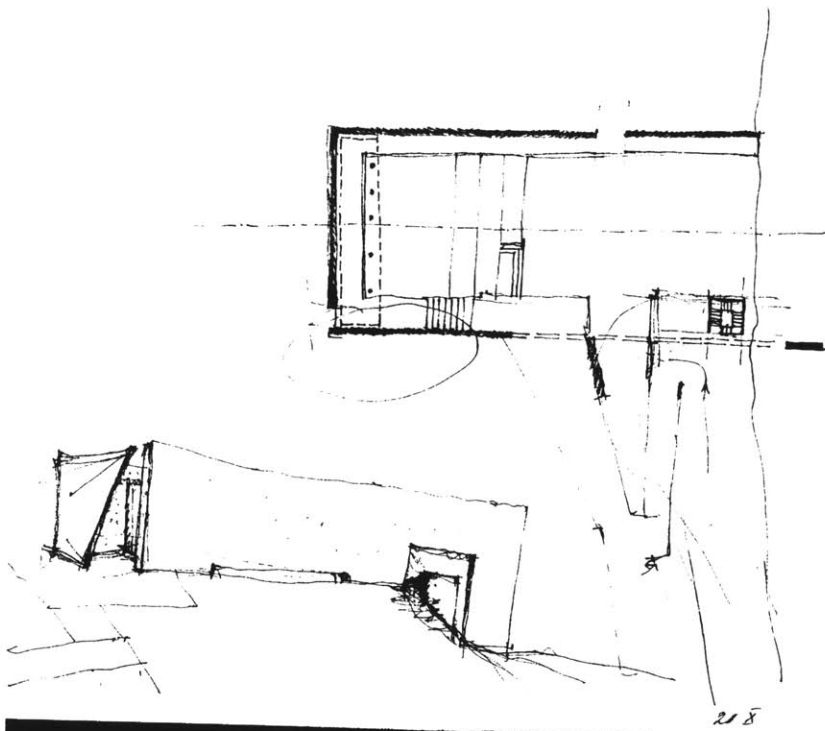

21 8

21 X

## **METAL SHIPS SECTION**

Within a question posed by the advisor, it was recognized that another site of memory contained the first impulses of the design. A ship yard was seen as a precedent in form, the large expanse of space at the edge of the water, containing yet releasing the flow of water. A few years ago an important place for me was the site of a ship dismantling yard, the former Kaiser Shipyards in Point Richmond, California, where Liberty ships were built during the Second World War. Here within the carcasses of ships hulls, conning towers and stacked rail cars were areas that appeared as natural and beautiful as a quiet countryside. While much of the site was neglected, work still progressed in another portion of the vast complex. The creak and groans of the huge cranes, the crash of unloaded material, and at night, the blackness cut by the work lights and sparks from the welding torches. Within this setting, seeming at times post apocalyptic, there was a feeling of security, amid the now quiet chaos, the scars of cut and torn material now rusting and settling in the ground, giants of industrial refuse pausing before being broken down further and constructed back into society.

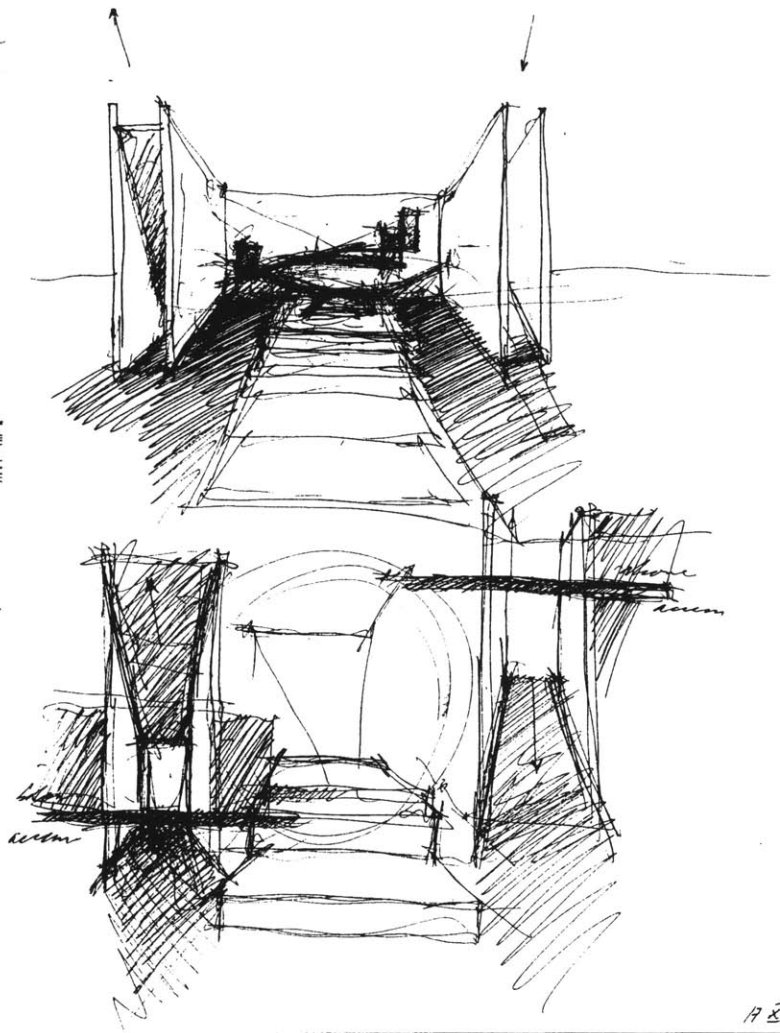
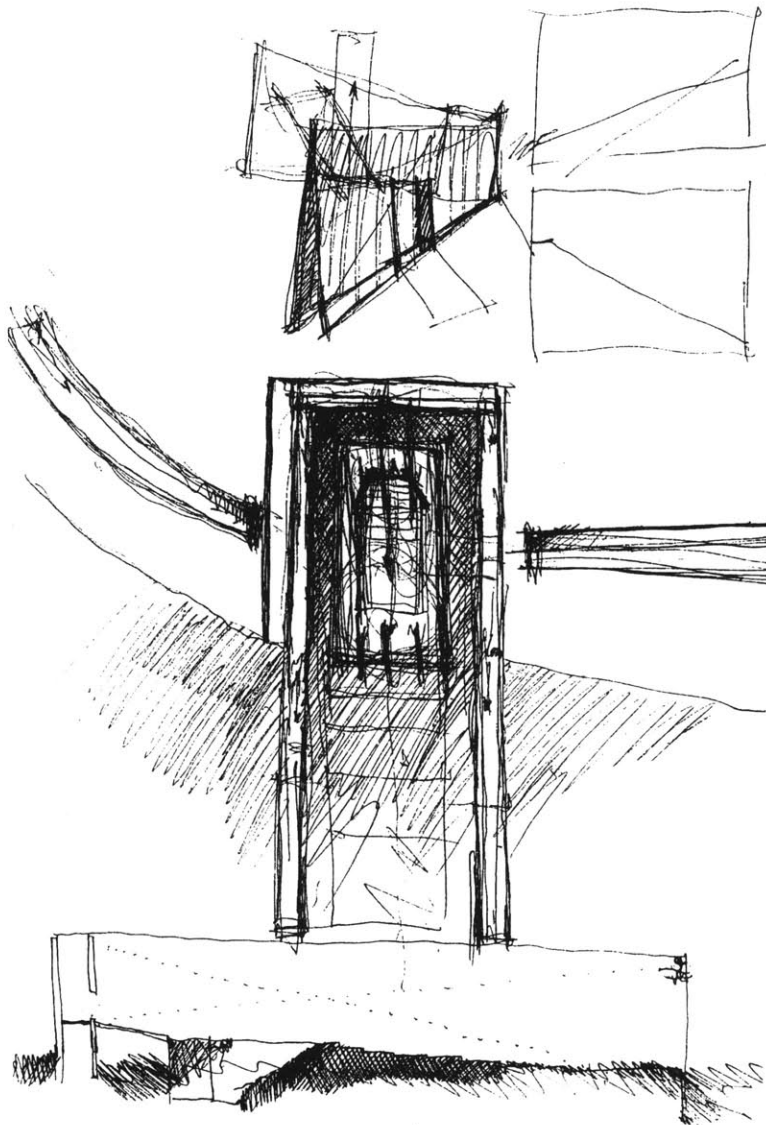

### **ADMONISHMENT: A Memorial For Future Wars**

The void carries the sense of abandonment. The ships, the hurrah's and glitter of medals, color bars of death, are gone. The widows and comrades are also gone, drifted, dry answers to half forgotten questions. No longer a politically viable ally the memorial sinks, neglect proliferates, the intentional nothingness becomes the site of destitution and the outcast. Soon thereafter an abandoned site is seen pregnant with the scratchings of graffiti, the unknown is thrust upon us and we yield, writing as a wound stitch. The abandoned is thus abused, rejected by the collective, it is declared a free territory for pillage and self sacrifice. I can scrawl my name on something once powerful and glorious, now succumbed to a momentary lecherous yearning, revealing in another way the political aspirations of the monuments birth. The memorial is born dead, unknown, incomprehensible.

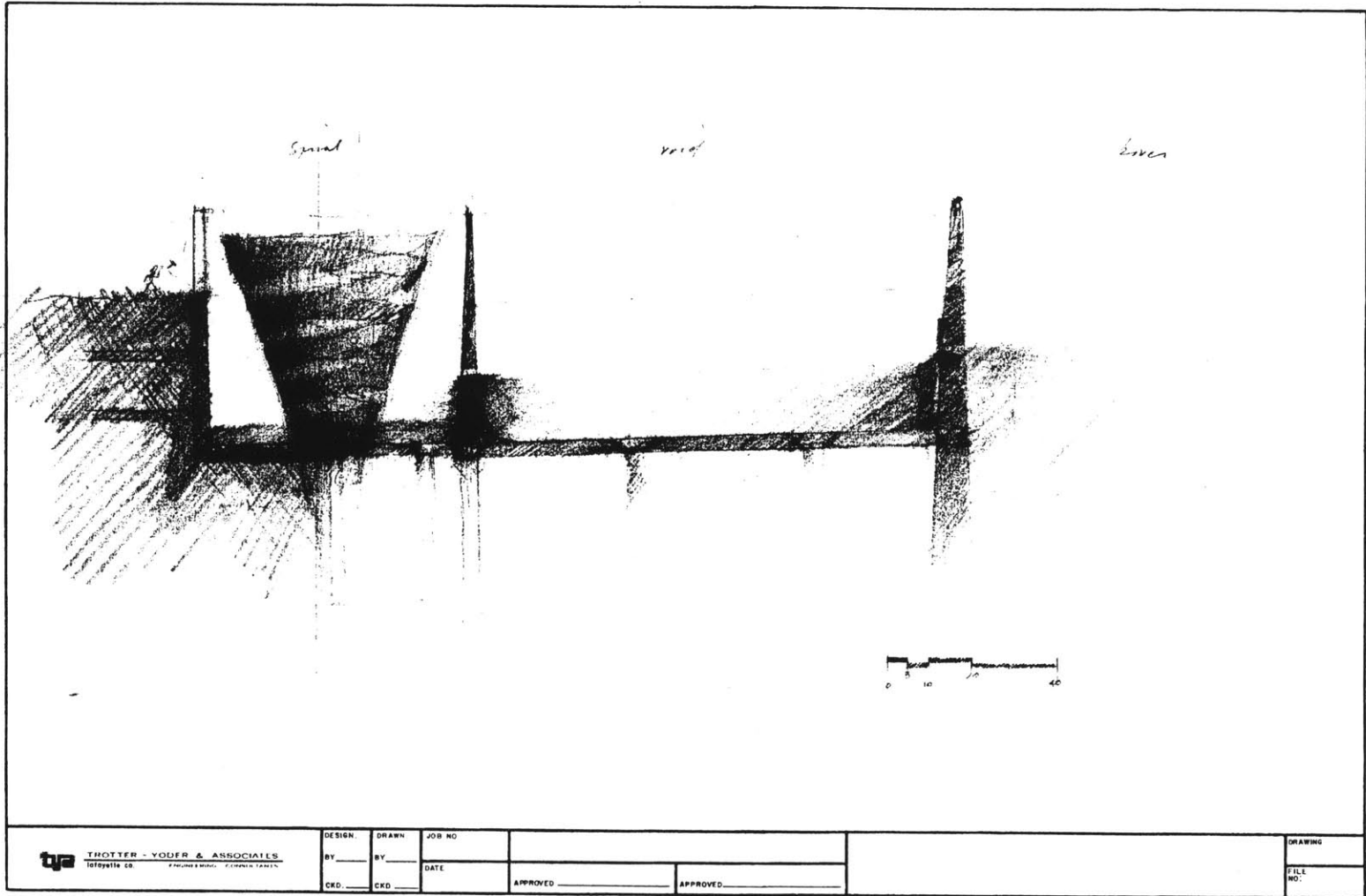

## SITES OF MEMORY

A program could begin with bibliographical notes, those scratches towards an empirical knowledge. This thesis is, after all, the unwoven thread of the past; sites of memory mixing with the apprehension of the present.

As a boy living in Israel, following the Six Day War, I had the hobby of collecting bullets, or any other residuals from spent explosive matter. A quarter's day bike ride from our house was the ruined remains of a munitions factory. It lay, to the boy's eye, in secrecy, in a fold in the sand dunes. Only the road a clue, being slightly browner than the rest of the desert, a trodden trail to the silent rusted carcass. Small gauge rail road tracks, for the munitions trolleys, radiated from the main building, ending abruptly in a rise of sand, or curving towards the skeletal remains of an out building, to be crisscrossed by fallen beams. Unfinished bullets, with razor sharp needle heads, lay scattered, as if pointing towards a thousand magnetic poles. On one occasion I found an unexploded artillery round, which I proudly carried down the dirt road. Flagging down some soldiers I presented them with the explosive, who to my disappointment, told me nonchalantly to bury it in the dunes.

Having a hobby of bullet collecting allowed both the training, as common to most hobbies, of observation and classification. The remains, bullets, shells, shrapnel, could be classified, in general size, in caliber, color, or degree of finish. Metal burnished with time in the sand, as smooth as it left the factory, or in frozen contortions. After a day of collecting I always sensed the presence of eyes, dead eyes, following me on the bicycle ride home. Whose cause of death did I carry in my satchel, now swinging rhythmically to the roll of the bicycle tires. In addition there was the necessity, at least at times, of remembering the fact, the killing, the flesh, the projectile's ultimate target.

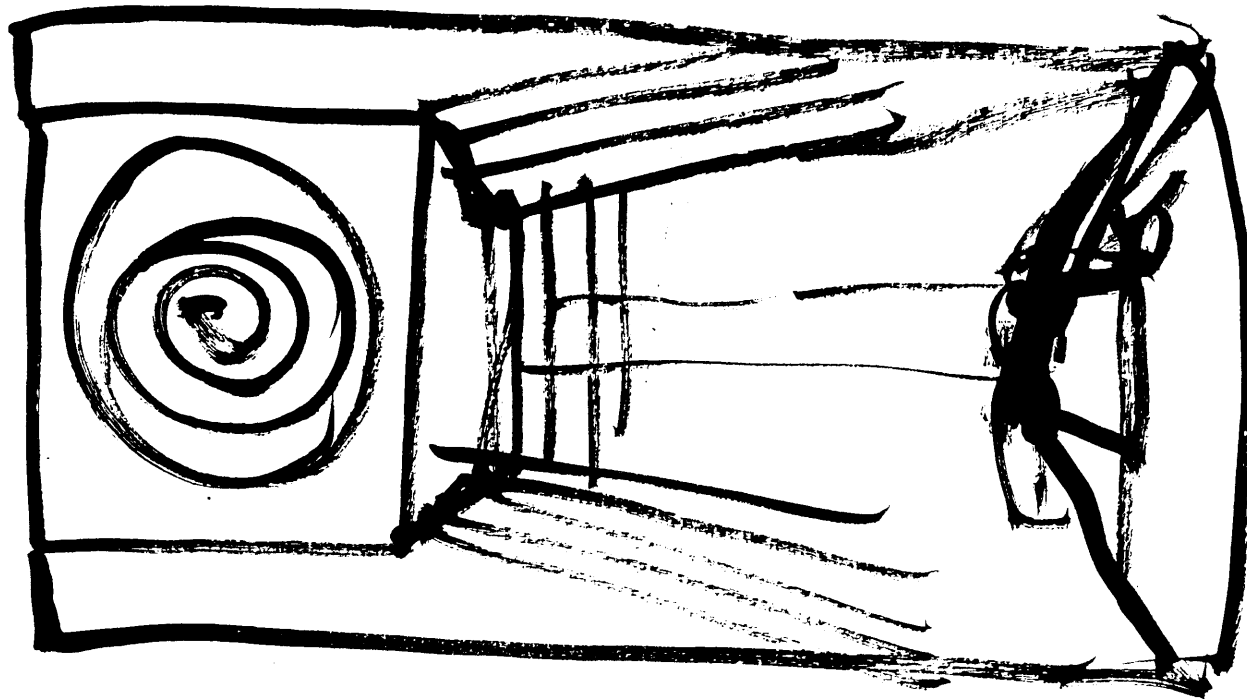

## **HANDS CLASPED (forming an architecture of worship)**

Often memorials are sacred places, yet they function within the secular. The purpose in this thesis is to present such a place without the iconography of a memorial, no dates, names, places, totems. Those sacred places whose functions have long been forgotten, to be perhaps transplanted by the seasonal migration of tourists, are precedents for this memorial. Similarly earthwork sculptures evoke an aura of unknown, enigmatic rituals.

The hands clasped in worship, religiously, within sacred walls, but words uttered unrecognizable: the language is not your own, except for the rhythm, one is deaf to the meaning. How much still is absorbed, remembered and carried. (The smell, taste and touch of an unknown church comes back to me, the baptism that occurred there merging with my own, with every baptism I see. I question even, was it my own?) The actions seen are absorbed within one's own memory, becoming meaningful in terms of one's own experiences. In this instance, I don't mind the mixing of my history with that of an anonymous boy. The experience fills a place where memory was empty. Amplify that, zero it a hundred million times until memory advances towards history. Your history is that of the collective, an invented collective. This memory is directed towards those who died, before your time, for the land, the nation in which you live.

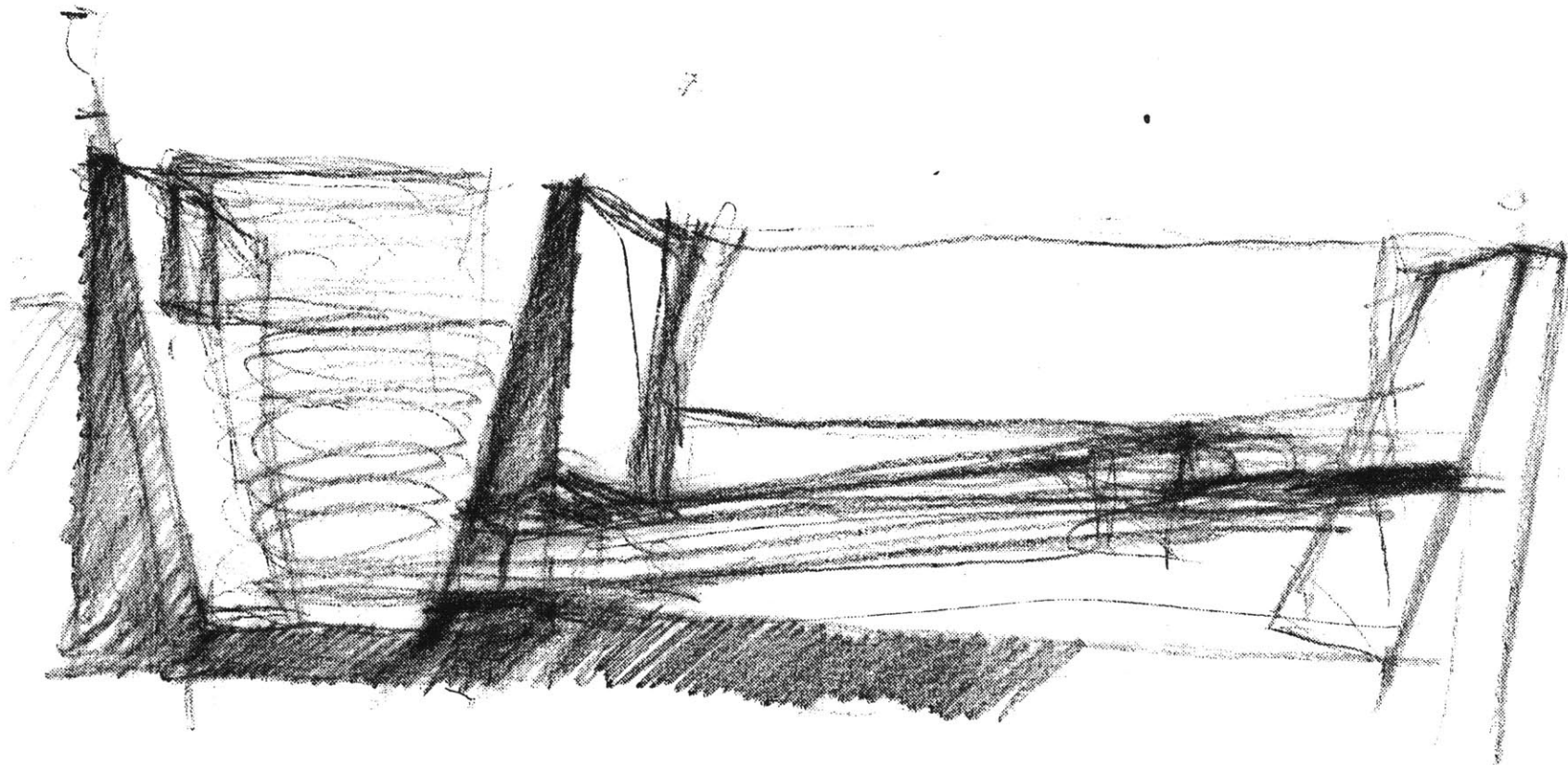

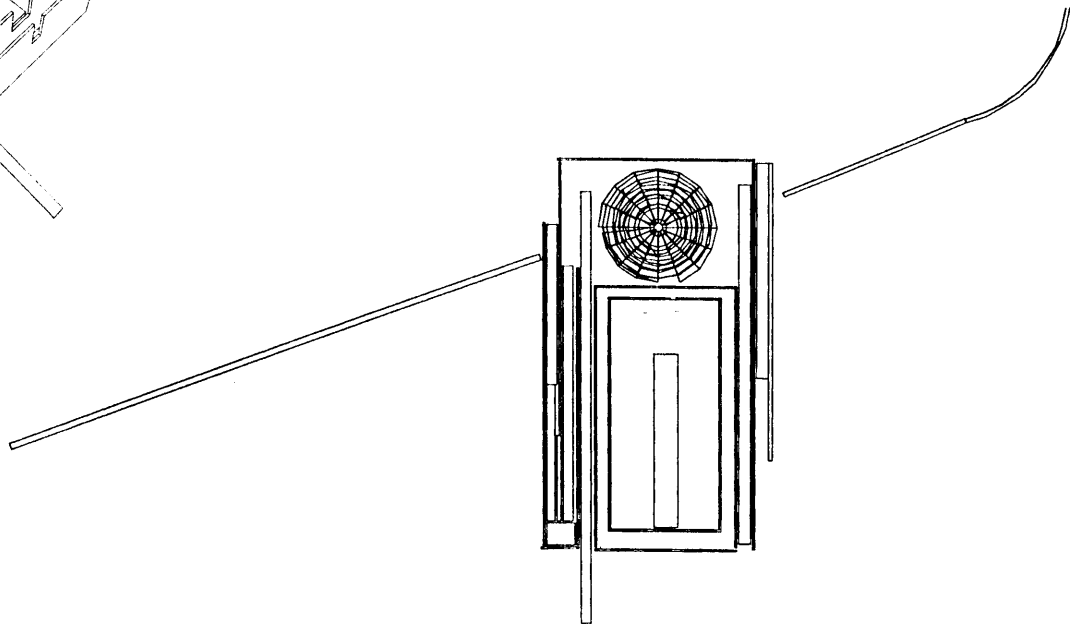
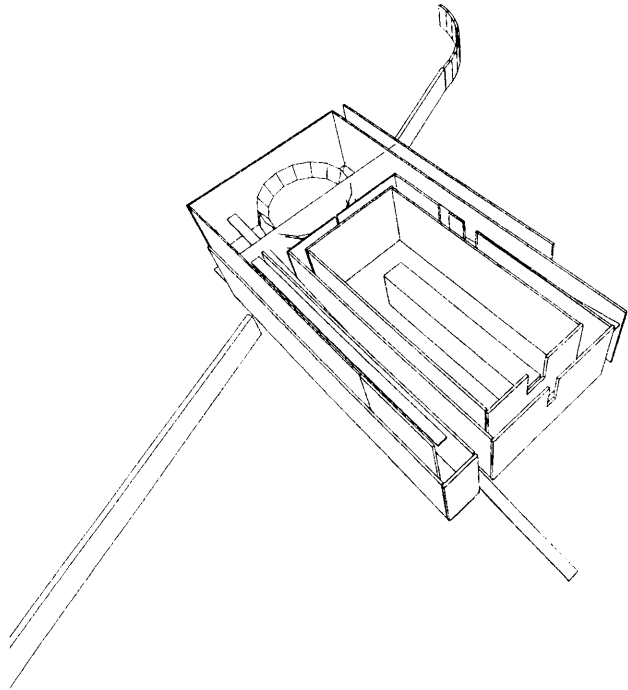

*Hudson River*

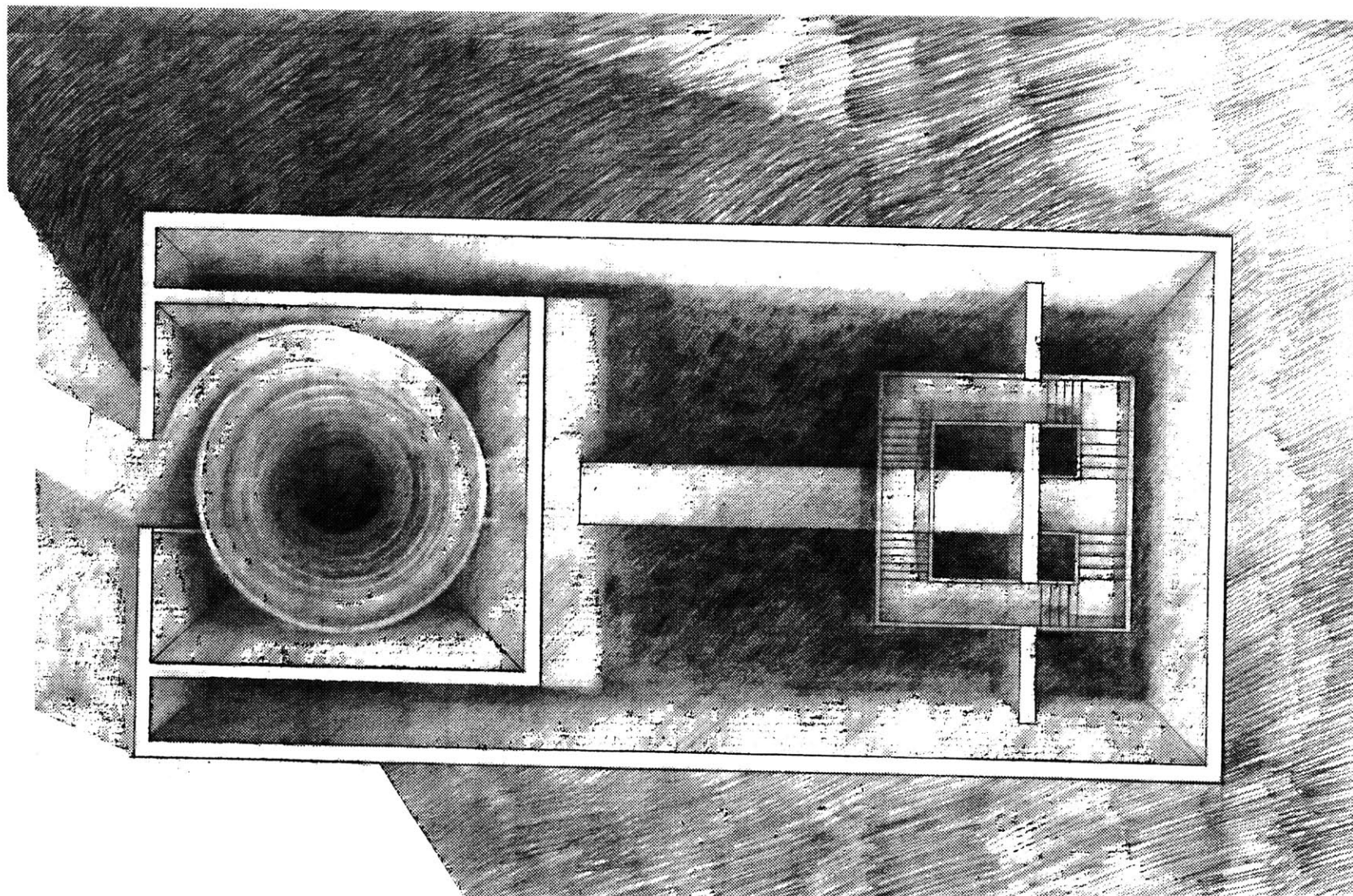

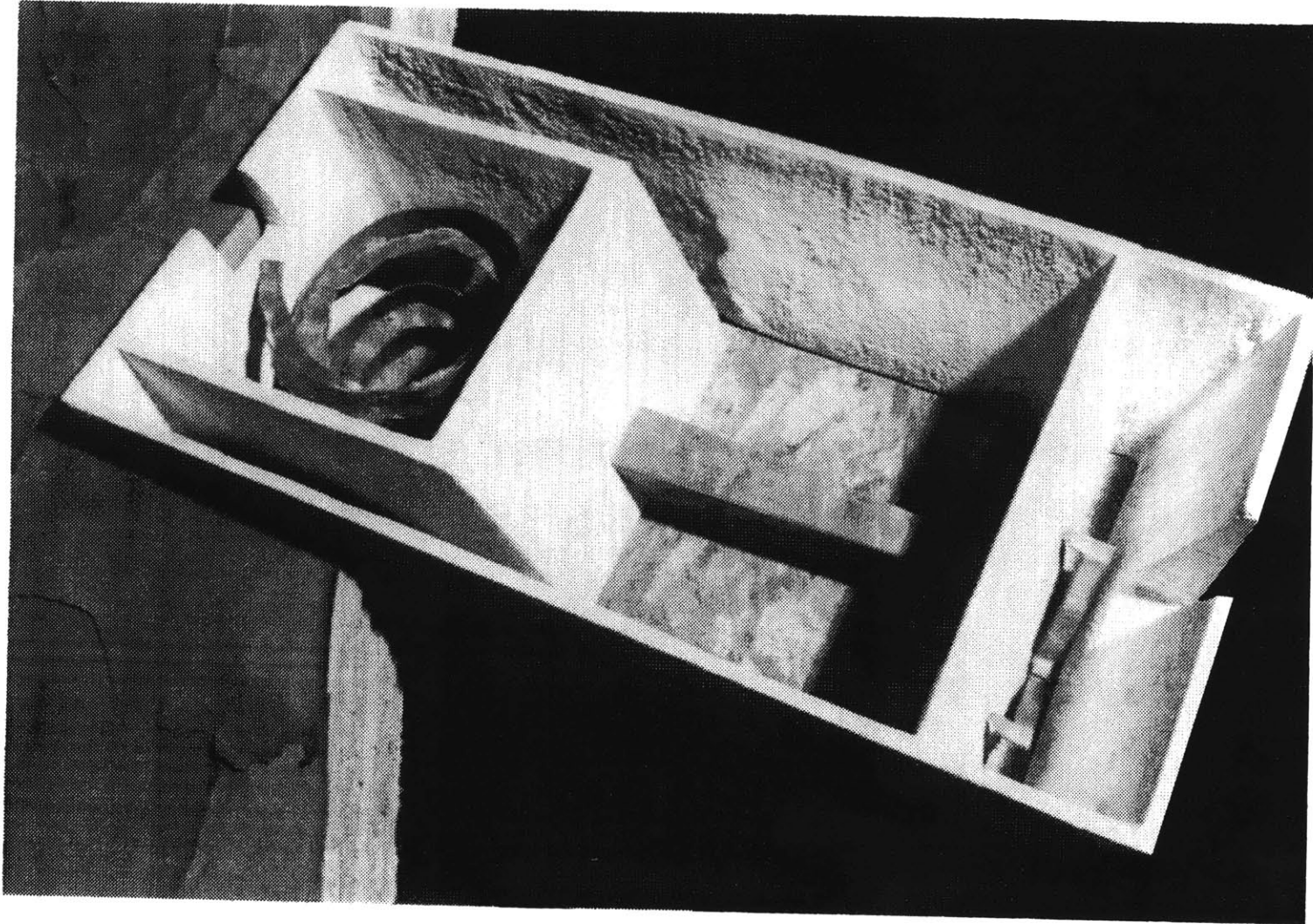

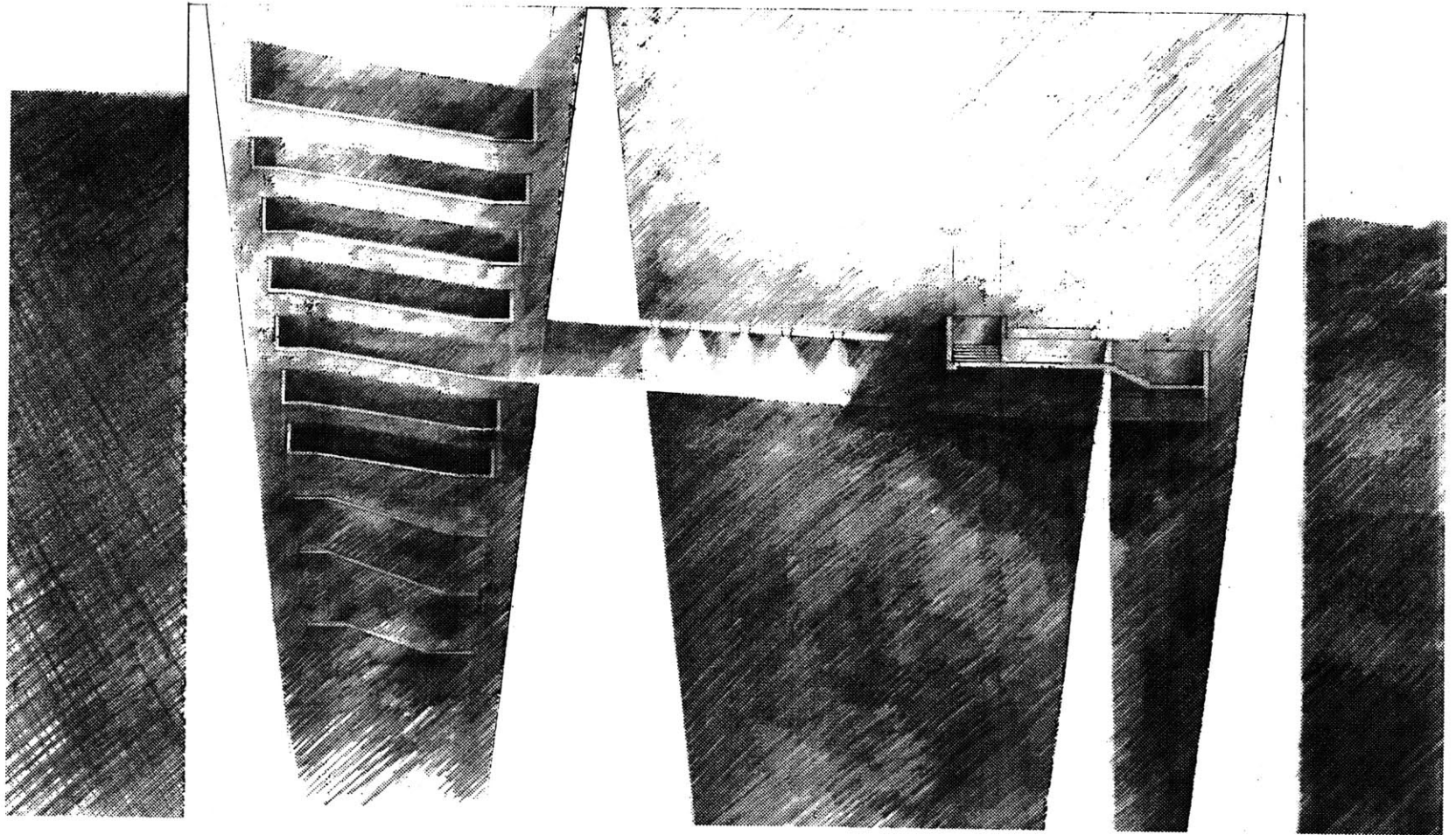

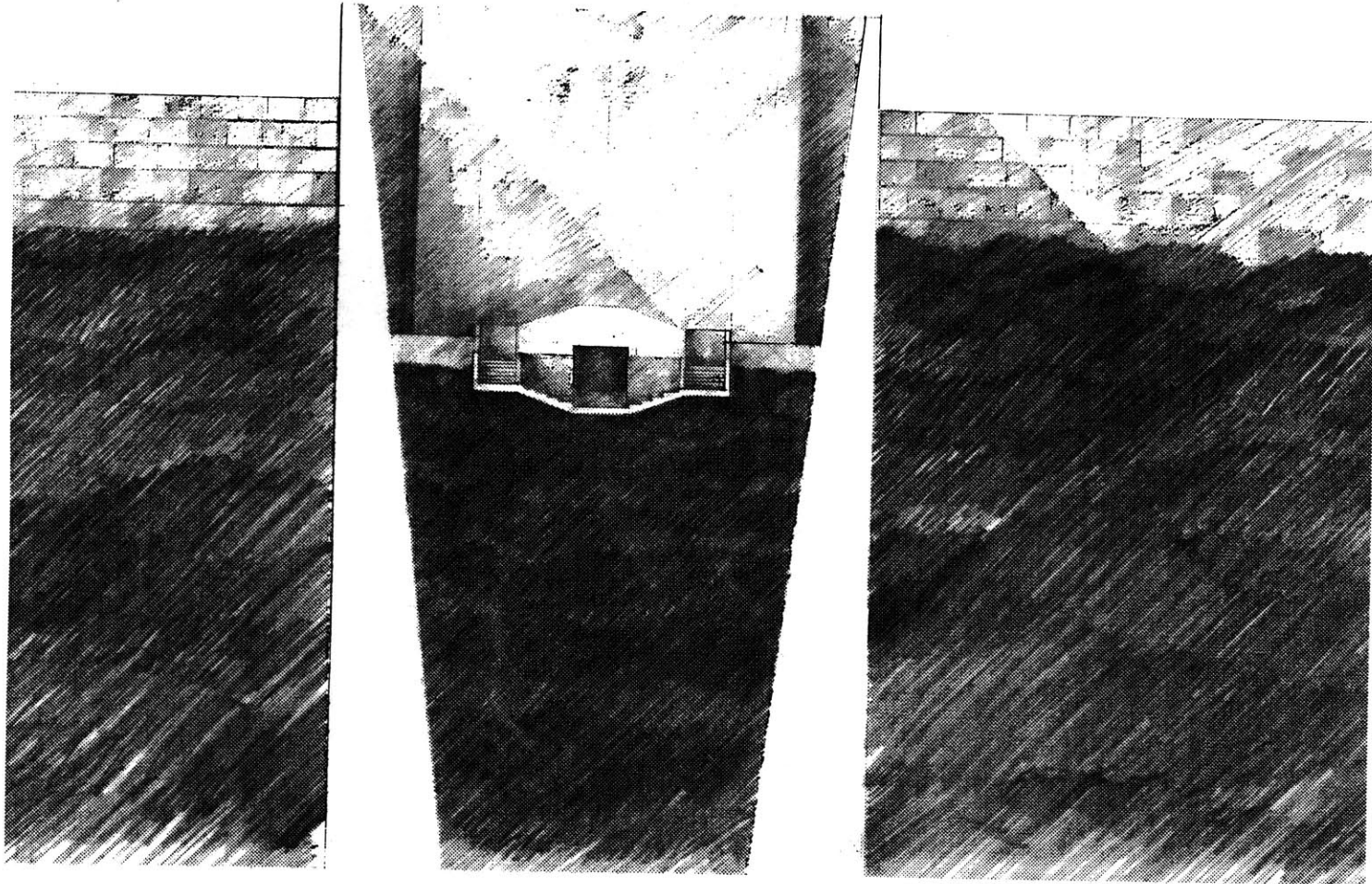

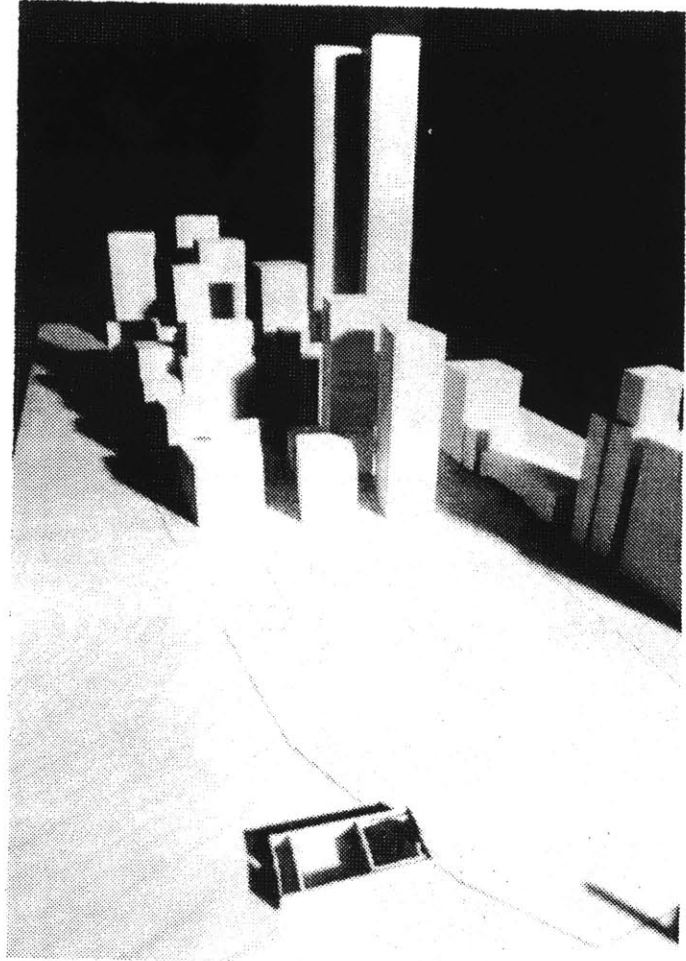
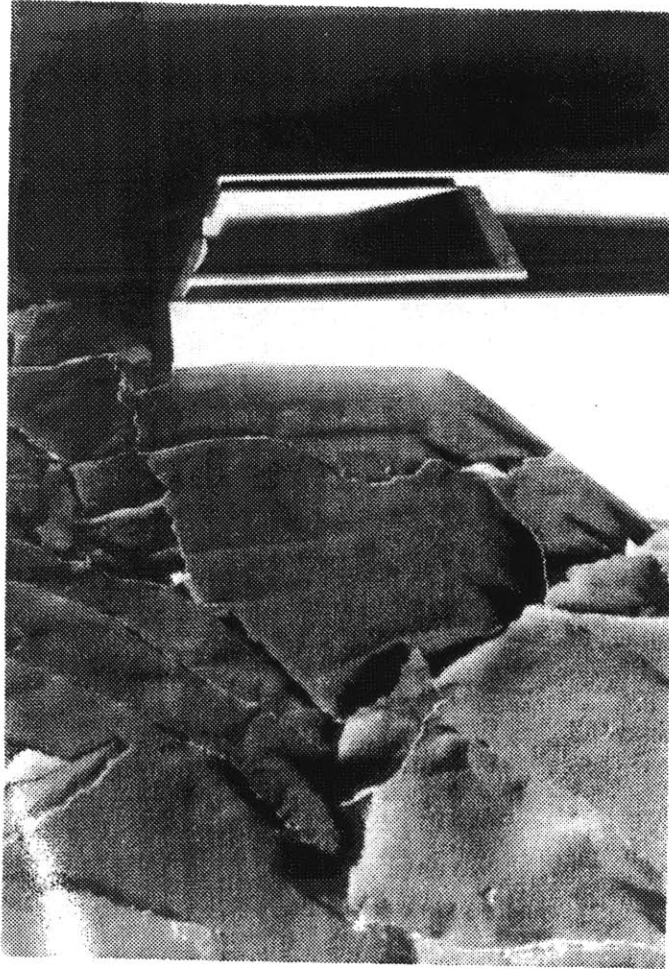

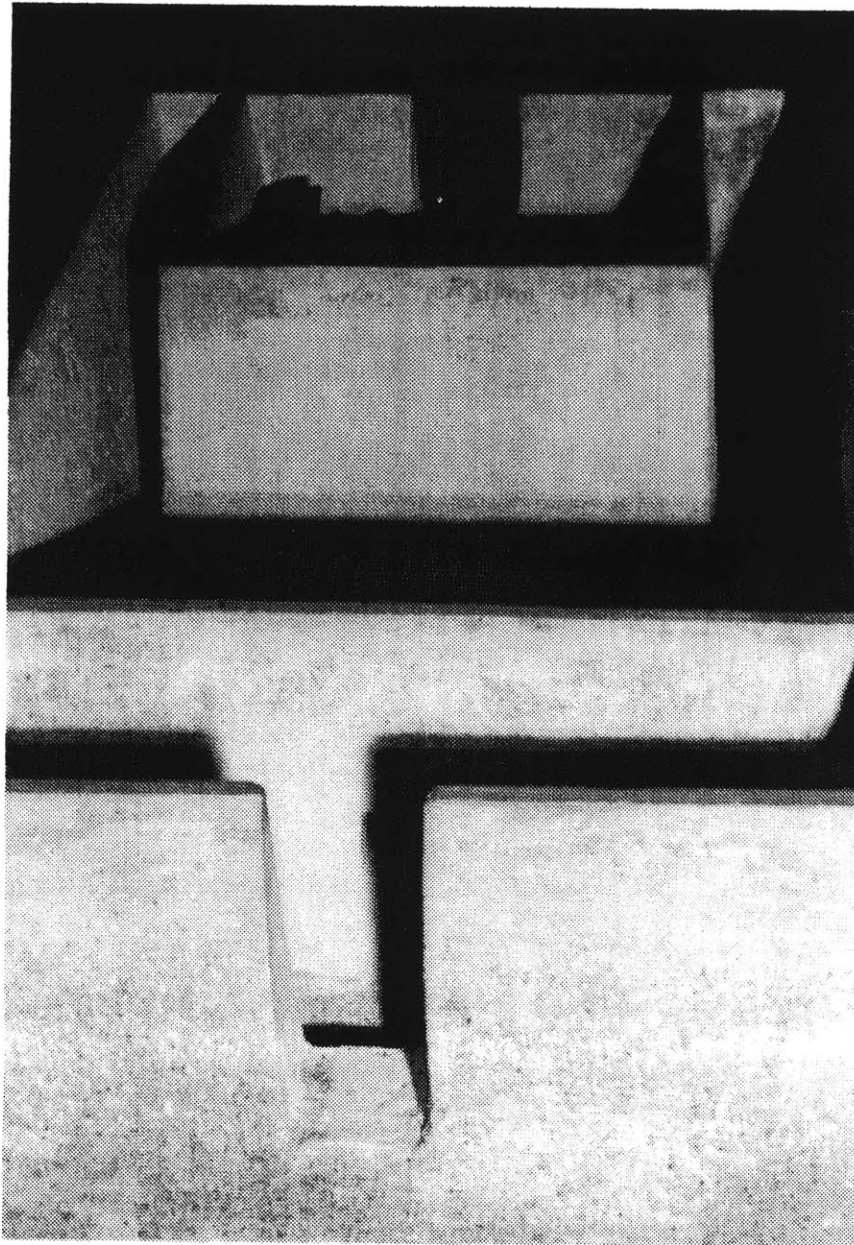

67

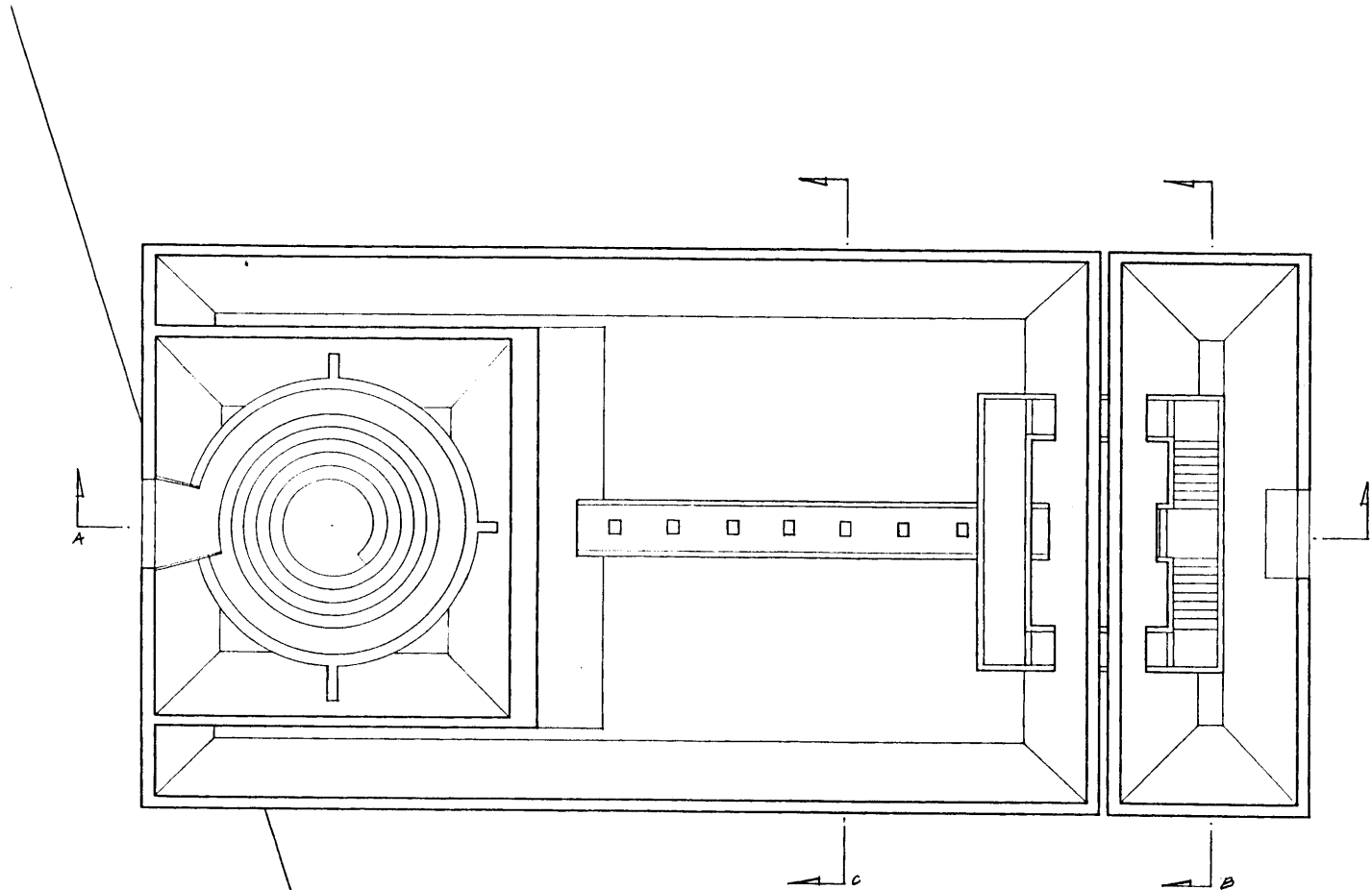

Hudson River

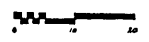

SECTION A

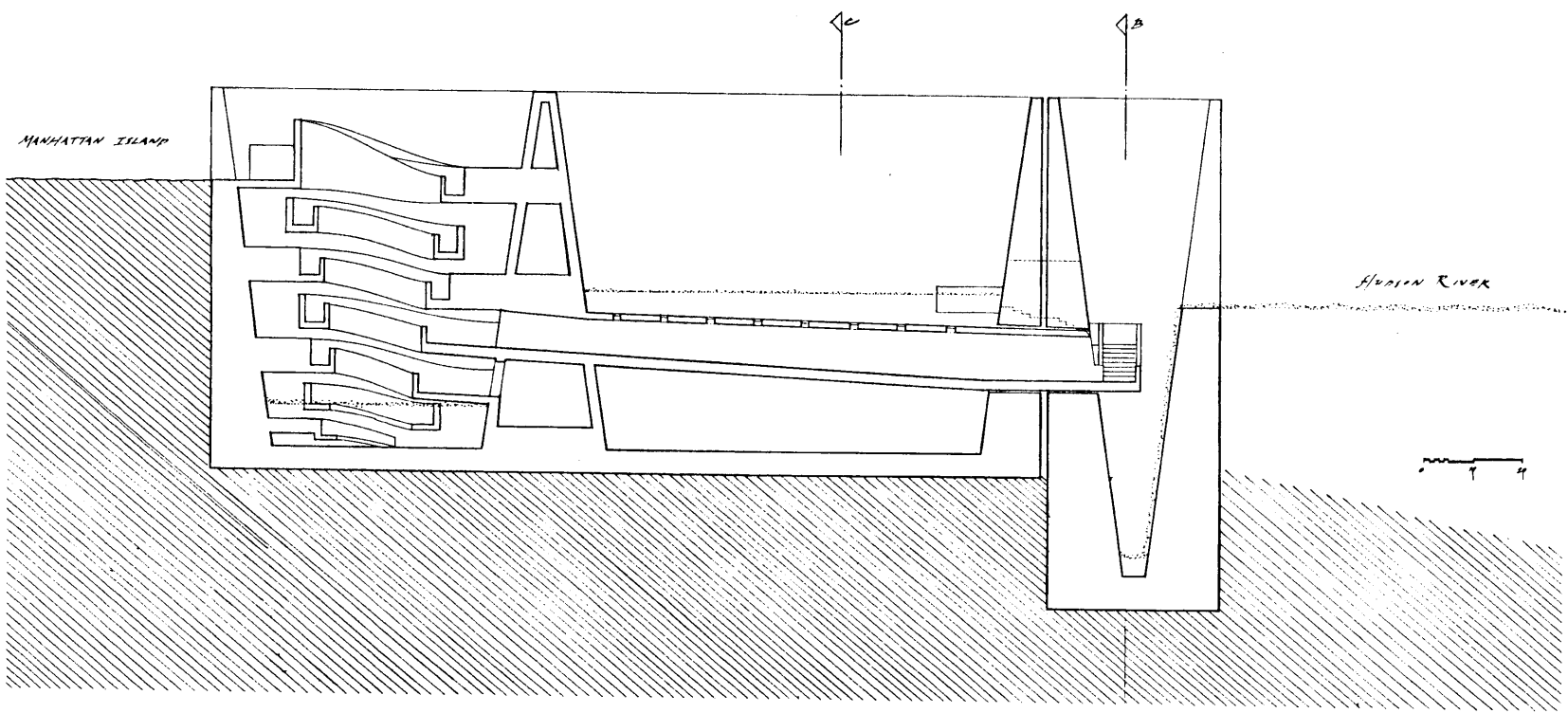

SECTION A

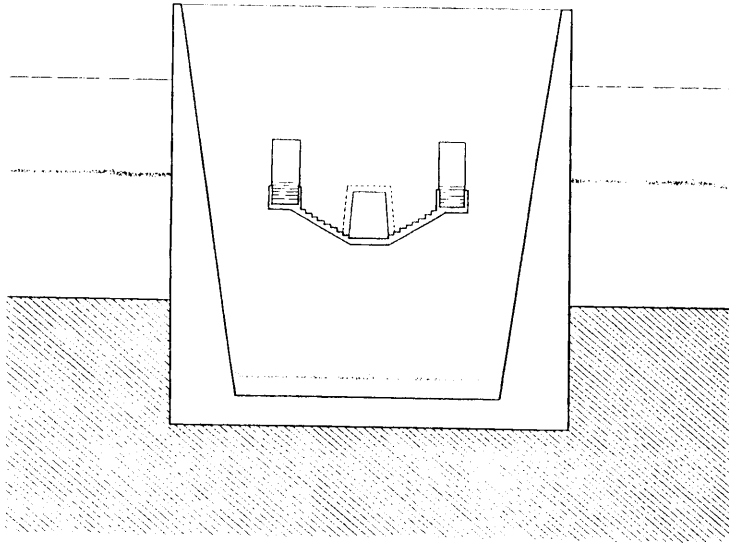

SECTION C

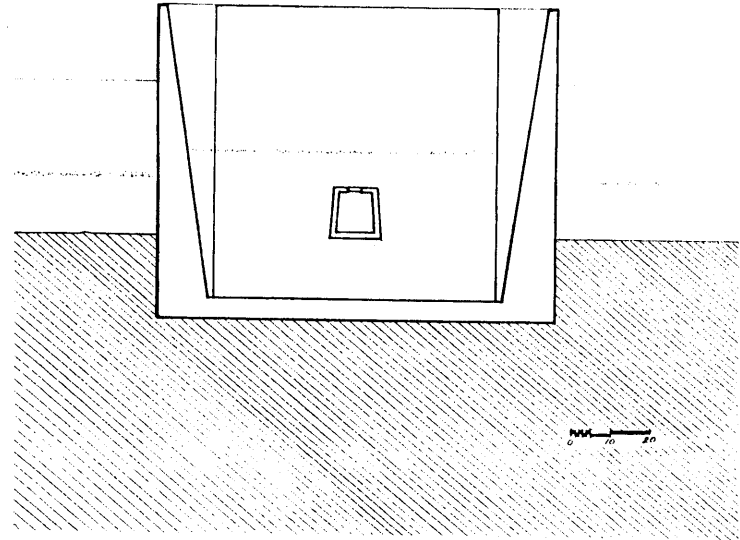

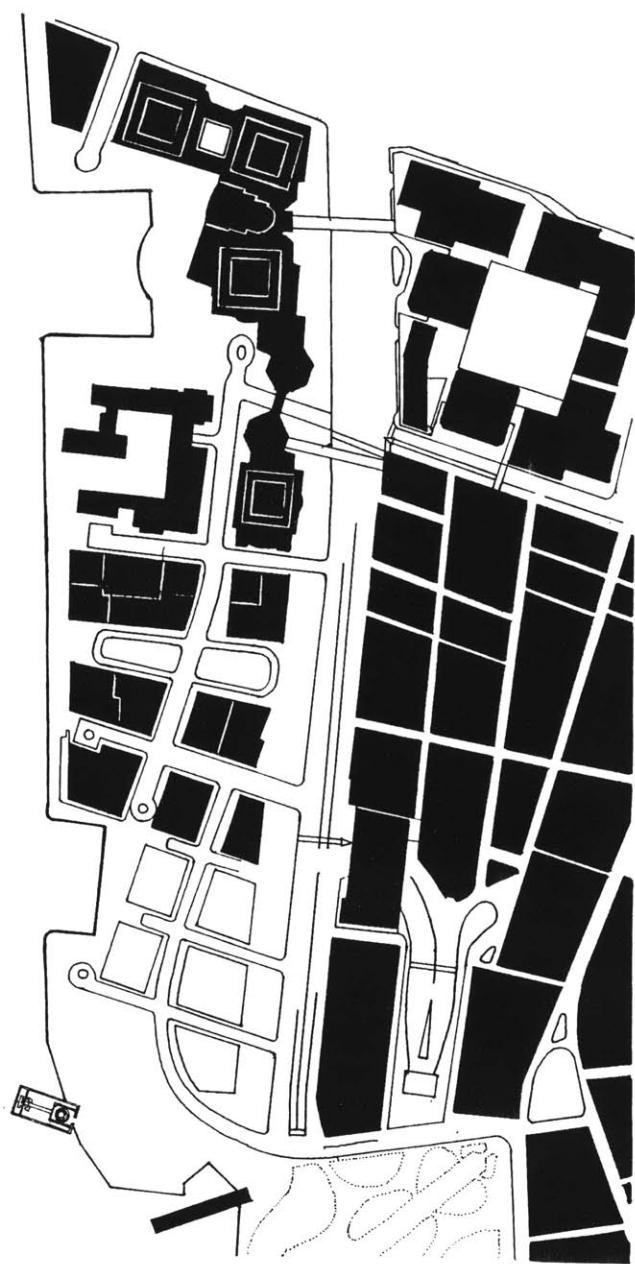

## ILLUSTRATIONS

All the monument and memorial photographs were taken by the author. Murat Germen photographed the models.

pg.

vi. conceptual sketch, plan.

2. Pier A Clock Tower, Battery Park, NYC.

3. East Coast Memorial, Battery Park, NYC.

4. New York Vietnam Veterans Memorial, NYC.

5. Wounded Knee Memorial, Canal St. at Manhattan Bridge, NYC.

6. Roots and Ties For Peace, UN Garden, NYC

7. Pre-revolutionary war canon, Battery Park, NYC.

8. Flanders Field Memorial, NYC.

9. upper: New York Life Insurance COo. Vietnam Veterans Memorial. Lower: New York Korean War Veterans Memorial, Battery Park.

10. Detail, Korean War Veterans Memorial, NYC.

11. East Coast Memorial, Battery Park.

12. Detail, Pier A Clock tower

14. USS Intrepid Sea-Air-Space Museum, NYC.

22. USS Intrepid, flight deck

27. USS Intrepid, Congressional Medal of Honor Hall

33. Foreground: Victory Park. Background; USS Intrepid.

34. Victory Park, NYC.

38. Victory Park and the USS Intrepid.

41. View looking south towards the site and in the background Pier A and the Statue of Liberty.

42. Ground view of the site looking south.

43-55 Notebook sketches, chronological.

57. ink brush sketch, plan.

59. Conceptual sectional sketch.

60. Computer rendering, preliminary design.

61. Final conceptual sketch, plan.

62. Final model, concrete and lead, 1-8" scale

63. Final conceptual sketch, E-W section .

64. Final conceptual sketch, N-S section.

65. Left: detail 1-8" model. Right: site model.

66. Detail 1-8" model, looking East.

67. Final design, ink drawing, plan.

68. Final design, ink drawing, E-W section.

69. Final design, ink drawings, N-S sections.

70. Figure ground lower Manhattan, with proposal.

73. Bell in the Clock Tower of Pier A, Battery Park.

## BIBLIOGRAPHY

Althusser, Louis. *Essays on Ideology*. London: Verso Editions, 1984.

Barber, Bernard. "Place, Symbol, and Utilitarian Function in War Memorials." In *People and Buildings*. Edited by Robert Gutman. New York: Basic Books, 1972.

Barthes, Roland. *The Eiffel Tower and Other Mythologies*. New York: Hill and Wang.

Bataille, Georges. *Visions of Excess: Selected Writings 1927-1939*. Minneapolis: University of Minnesota Press, 1985.

Blatner, Henry LeRoy. "War Memorial for New York State Dedicated To Peace." *Master of Architecture Thesis*. Cambridge: MIT, 1935.

Deleuze, Gilles, and Felix Guattari. *A Thousand Plateaus: Capitalism and Schizophrenia*. Minneapolis: University of Minnesota Press, 1987.

Doezema, Marianne, and June Hargrove. *The Public Monument and its Audience*. Cleveland: Cleveland Museum of Art, 1977.

Evans, Thomas W. "The New York Korean War Veterans Memorial Commission." Press release. New York: Art Commission of the City of New York, September 28, 1989.

Genauer, Emily. "This Week In Art." *New York World-Telegram* (September 21, 1945).

Harbison, Robert. *The Built, The Unbuilt, and The Unbuildable: In Pursuit of Architectural Meaning*. London: Thames and Hudson, 1991.

Hobsbawm, Eric, and Terence Ranger, eds. *The Invention of Tradition*. Cambridge, New York and Melbourne: Cambridge University Press, 1983.

Hollier, Denis. *Against Architecture: The Writings of Georges Bataille*. Cambridge: The MIT Press, 1989.

Hubbard, William. "A Meaning for Monuments." *Public Interest*, no. 74 (Winter 1984).

Mayo, James M. *War Memorial as Political Landscape*. New York: Praeger, 1988.

McLeod, Mary. "The Battle for the Monument: The Vietnam Veterans Memorial." In *The Experimental Tradition: Essays on Competitions in Architecture*. Edited by Helene Lipstadt. New York: The Architectural League of New York and Princeton: Princeton Architectural Press.

Reynolds, Donald Martin. *Monuments and Masterpieces: Histories and Views of Public Sculpture in New York City*. New York: Macmillan, 1988.

Riegl, Alois. "The Modern Cult of Monuments: Its Character and Its Origins." *Oppositions* (Fall 1982).

Sert, Jose Luis, Fernand Leger, and Sigfried Giedion. "Nine Points on Monumentality." *Harvard Architecture Review IV* (1984): 62-3.

Strait, Jerry L., and Sandra S. Strait. *Vietnam War Memorials: An Illustrative Reference to Vietnam Tributes throughout the United States*. Jefferson, NC: McFarland, 1988.

Tzu, Sun. *The Art of War*. Boston and London: Shambhala, 1988.

73

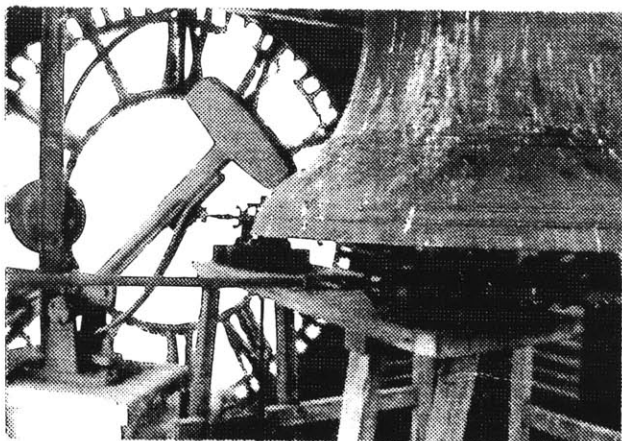

5871-13