

THE SUMMIT HOUSE: Forces and Forms Cooperating
in an Extreme Environment

by Eliot Warren Goldstein
B.S.A.D., M.I.T., 1977

Submitted in Partial Fulfillment of
the requirements for the Degree of

MASTER OF ARCHITECTURE

at the MASSACHUSETTS INSTITUTE OF TECHNOLOGY
SEPTEMBER 1980

Signature of Author
Department of Architecture
June 1980

Certified by
Maurice Smith, Thesis Supervisor
Professor of Architecture

Accepted by
Maurice Smith, Chairman, Departmental
Committee for Graduate Students

Rotch
MASSACHUSETTS INSTITUTE
OF TECHNOLOGY

SEP 25 1980

LIBRARIES

© Eliot Warren Goldstein, 1980

The author hereby grants to
M.I.T. permission to reproduce
and to distribute publicly
copies of this thesis document
in whole or in part.

THE SUMMIT HOUSE: Forces and Forms Cooperating
in an Extreme Environment

by Eliot Warren Goldstein
B.S.A.D., M.I.T., 1977

Submitted to the Department of
Architecture on June 16, 1980,
in partial fulfillment of the
requirements for the Degree of

MASTER OF ARCHITECTURE

Abstract

Summit houses are intended to provide dining and sleeping facilities for the hikers of summer and the skiers of winter.

The summit house is examined as a building type. The Green Mountain climate is analyzed. A site is chosen in order that specific, as well as general, issues can be addressed during the design process.

Protection is provided from only those aspects of the environment which pose a threat to the health or safety of the users. A cooperative attitude is defined toward the site and toward the climate. Natural forces are harnessed to reinforce selected architectural intentions. Natural forms which have evolved in a protective response to strong winds and various thermal actions are identified. The most effective of these are subsequently composed of or contained in built forms exposed to similar stresses.

The relationships between winter and summer uses are clarified. Building materials and techniques and the qualities of access and enclosure are varied in response to daily and seasonal changes in the climate and in the activities it allows. A positive attitude toward continuity with the landscape is used as a generator of local and total building form.

Thesis Supervisor: Maurice K. Smith
Title: Professor of Architecture

Acknowledgements

Of the many who have contributed to this project, the following deserve special mention:

My parents, for encouragement to pursue, and endless constructive criticism during the development of the ideas which follow.

Brother Roger, for sharing with me his perspective on the process of doing a thesis, as well as his criticism.

Brother Ray, for constantly reminding me of the importance of writing for a general audience.

My advisor, Maurice K. Smith, for not letting my intentions get lost, and for having pulled out of me the beginnings of some good work.

My readers, Edward Allen and Gunther Nitschke, for reminding me that there are endless ways of dealing with every issue.

The National Endowment for the Arts, for funding my research in the Alps, during January 1980.

Messrs. Frutiger and de Quervain of the Federal Institute of Snow and Avalanche Research, Weissfluhjoch, Davos, Switzerland, for their help in making my brief research mission extremely productive.

Messrs. Flanders, Mellor, and Tobiasson of the U.S. Army Corps of Engineers Cold Regions Research and Engineering Laboratory, Hanover, New Hampshire, for sharing a wealth of information with me about all aspects of cold-climate construction, but particularly about the problems of drifting snow.

Messrs. Bartschi, Indergand, and Jost, for their insights concerning traditions and regulations associated with alpine village architecture, the lifestyle and building methods of the people of Schuders, and the part that lawinen-keil and foehn play in the alpine existence.

The architects of the new Mt. Washington Summit House, Dudley, Walsh, and Moier, Concord, New Hampshire, for detailed information about the problems of building on the windiest site on earth and the solutions they have proposed.

Mike Pyatok, for having provoked this study of snow-country design unintentionally.

Frank Miller for encouraging me to define a topic which allowed examination of many areas of personal interest simultaneously.

Officials of the Rocky Mountain Forest and Range Experiment Station, Fort Collins, Colorado, the Back-country Research Program, Durham, New Hampshire and the National Research Council of Canada/Division of Building Research, Ottawa, for the wealth of valuable material they provided.

My friends and colleagues at the Smugglers' Notch Ski Area and in the Professional Ski Instructors of America, for showing me both the beauty and the challenge of the mountains over these last four years.

Contents

	Abstract	3	
	Acknowledgements	4	
	Contents	6	
	Foreword	9	Attitude Setting Process Concept
Part I: FORCES	1) The Sun	16	Solar Grain Fixed Responses Adjustable Devices Thermal Zones Materials Transformations
	2) The Wind	32	Fluid Grain Natural Forms Directional Devices Redirectional Devices

Part II: FORMS	3) The Ground	42	Ground Grain Fixed Responses Adaptation Association
	4) The Climate	50	Natural Transitions Protection Built Transitions
Part III: COOPERATION	5) Building Process	58	Materials Methods Directions Growth
	6) Total Form	82	Differentiation Continuity Public Form
	7) Afterword	89	Consistency Alternatives
APPENDIX	Bibliography	91	Philosophy Concept Environment Construction Form
	Program	103	Winter Summer

Foreword

The primary motivation for voluntarily building in the mountains has always been to maximize one's involvement with a dramatic site and an extreme climate. It is surprising, therefore, that the New England summit house has been called upon to provide only:

REFUGE from the cold and wind,

PROTECTED PLACES to eat and to sleep

and SELECTED VISTAS of the surrounding landscape.

The attitude underlying this thesis is that it is necessary to provide both shelter from and exposure to the forces of nature if the alpine experience is to be a healthful and meaningful one.

Although shelter is needed from the winter winds, summertime breezes are welcome. While the ground is white with snow in winter, it is the dark color of earth and rock in summer. The transience of the snowpack contrasts sharply with the relative permanence of the real ground.

Although the continuity of paths and the integrity of natural transitions should be maintained, the differences between the landscapes, the temperatures, and the activities of June and January must be emphasized. This principle has been stated well in another context:

...The sharing that occurs in deep relations of intimacy grows out of loving the distinctiveness, the uniqueness of the other person, not in the merging of selves into one homogenized being.

Attitude

D. de Rougemont in Sennett, p. 39.

Two groups of users will be assumed: skiers and hikers. Their seasons of use often overlap. The skiers of winter are usually day-visitors seeking shelter and warmth. The hikers of summer often bring their shelters and heat with them, in the form of tents and stoves, and seek an intense outdoor experience. All come to the mountain in order to reach its top. All should have the option to spend the night there. The issues to be addressed include:

the provision of THERMAL TRANSITIONS between the exterior and interior environments,

ORIENTATION to the sun and to features of the natural landscape,

CONSTRUCTIVE EMPLOYMENT of seasonal variations in the qualities of natural light and ground-cover,

ACCESS to and MOVEMENT through the site,

the DEFINITION OF BUILDING METHODS and the DEPLOYMENT OF BUILDING MATERIALS sympathetic to the topographic and micro-climatic characteristics of the site.

Process

Setting

Although it is composed of typical Green Mountain topographic features, the overall site is imaginary. In order that there be a high level of involvement between the site and the building, each had to be malleable at several scales. The building is located near a 4000' Green Mountain summit, and, for reasons to be elaborated upon later, on the northeastern face of the mountain. It is above a ski area and is reachable in winter by a ski lift and tracked snow vehicles. A well-maintained footpath provides access in summer.

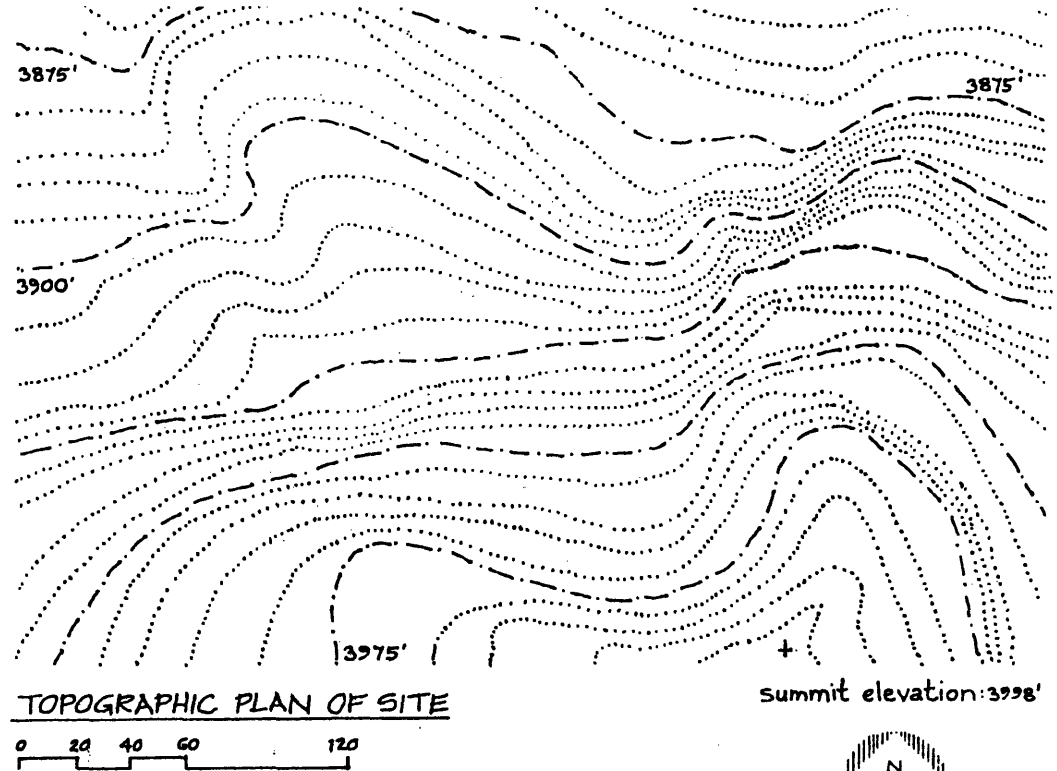

The design process consisted of three phases. The extreme natural forces acting at the alpine summit were identified first. The natural

forms generated by them and the built forms developed to cope with them were analyzed. Architectural alternatives were proposed which

manifested the directional aspects of the natural forms while solving the problems addressed by the built forms. In some cases, the options were generic ones. They could be employed effectively at sites of similar topography or in regions of similar climate. In some cases, the options could only be useful for the specific set of environmental conditions at the proposed site.

The second phase of the process involved analysis of the natural forms which result from the combined effects of several natural forces. Each type of precipitation, for example, forms only when a somewhat unique combination of winds and temperatures is present. Physical forms which are intended to operate best in the same narrow environmental range must still be useful when one (or more) of those conditions is not present. A number of formal precedents were examined.

During the third phase of the work, building methods were proposed to address issues of continuity with the form of the site and differentiation of space in response to climatic extremes. A study model was produced to explore architectural form both as it related locally to forces and activities dominant in specific building locations and as it related in its entirety to the ongoing landscape and the overall climate.

The model made it clear that a holistic design approach was required. What needed designing was not just a building, but an entire environment whose natural components were in very delicate balance. The total form was influenced as heavily by paths to the summit and ski trails as by the path to the building proper. The form of the entry court resulted as much from the type of lift serving it as from the qual-

ities of sunlight striking it.

The interconnectedness of the environmental aspects led to a non-linear design process. It had been intended originally that the second phase of the work would follow the first, and so on. It quickly became apparent that understanding of the issues could not be complete without

formal exploration of them in the model. Similarly, work on the model could not proceed until issues had been identified and attitudes toward them established. Because the concepts and forms guided the development of each other, sketches and photographs of the model appear with and are described in the text.

Concept

What, then, are the constructive uses of powerful natural forces? Of the useful forms generated by natural forces, which should have analogues in the built environment? How can the natural forces and built forms at the alpine summit be combined to produce a recreational facility heavily involved with its site and its extreme climate?

A discussion of natural and built form must begin with definition of the concept of grain. As used throughout this document, grain will refer to the physical characteristics which have been applied to or emphasized in materials as a result of an in the directions of the natural forces acting on them.

Grain can be found, for example, in the fur of a cat. It lies

smoothly in only one direction, the direction of least wind resistance. Similarly, buildings have grain. Wall shingles are applied with respect to the direction in which water flows under the force of gravity.

Three types of grain will be examined: solar grain, fluid grain, and ground grain. Although others exist, these three have the most influence at the alpine summit.



FORCES

The Sun

Solar Grain

Vitruvius

...in summer the heat makes everybody weak, not only in unhealthy but even in healthy places ...in winter even the most unhealthy districts are much healthier because they are given a solidity by the cooling off. Similarly, persons removed from cold countries to hot cannot endure it but waste energy; whereas those who pass from hot places to the cold regions of the north, not only do not suffer in health from the change of residence but even gain by it.



'Solar grain' describes the natural and built manifestations of the daily movement of the sun across the sky and the seasonal changes in the size of its arc and its altitude. *Alpine buildings, like plants, must lean toward the sun to maximize wintertime exposure to its rays.*

The dormer is an ancient architectural device which embodies solar grain. Just as a suspension bridge is a map of the magnitude of the forces acting within it, the edge of a south-facing gable dormer is a linear approximation of the sun's movement across the sky. The sun is lowest when it shines on the low east and west eaves, and highest when aligned with the peak of the gable. The rake details of farmhouses in the French Alps include ornate semi-circular screens which even more closely match the daily solar arc. Gable roofs with steep

glazed south-facing panels and vertical endwalls have the advantage that the sun's rays will strike normal to their surfaces not only in plan, but in section, when coming from the east, the west, and the south.

Natural light can be responded to in a number of other ways. The moat around Saarinen's Kresge Chapel at M.I.T. reflects daylight through horizontal glazing onto the rippled walls and ceiling of the interior. At Johansen's Goddard Library at Clark University, south-facing study

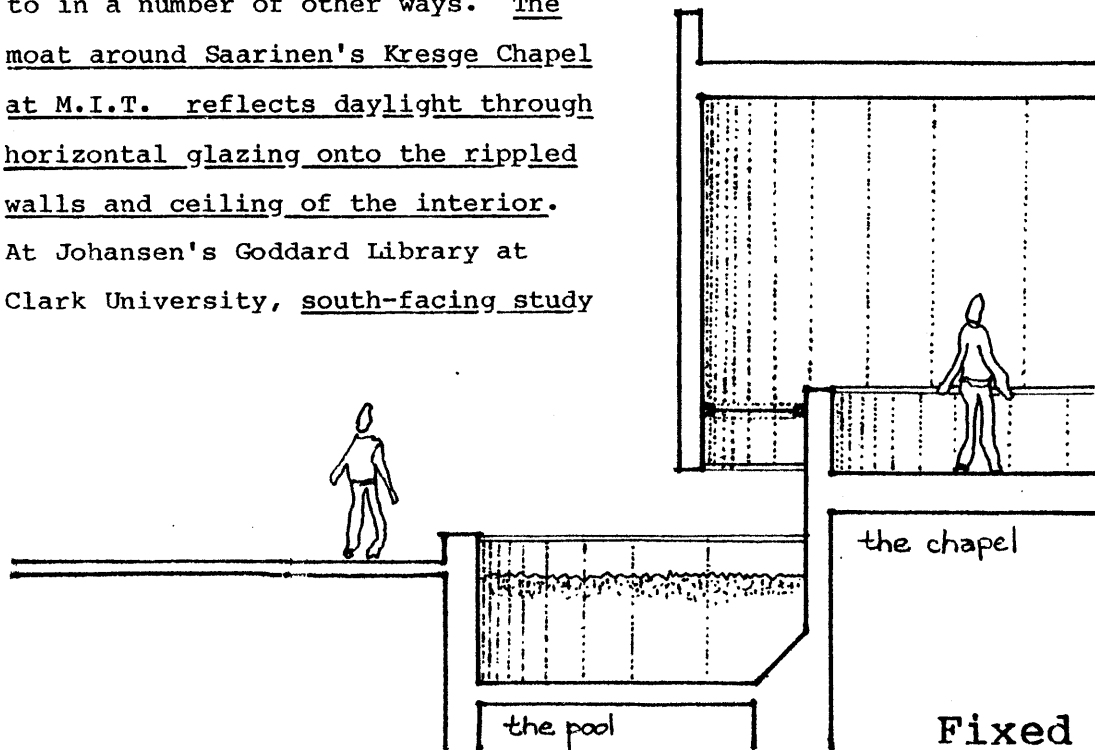
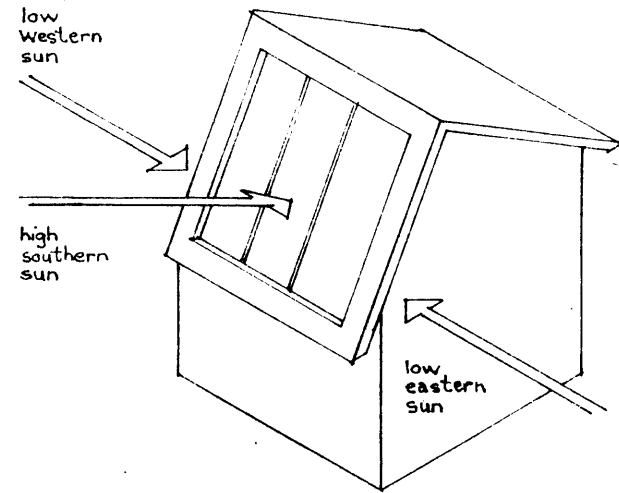
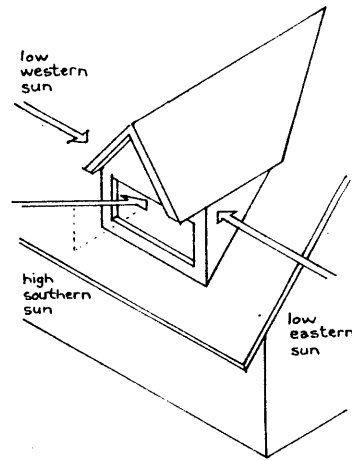

Fixed Responses

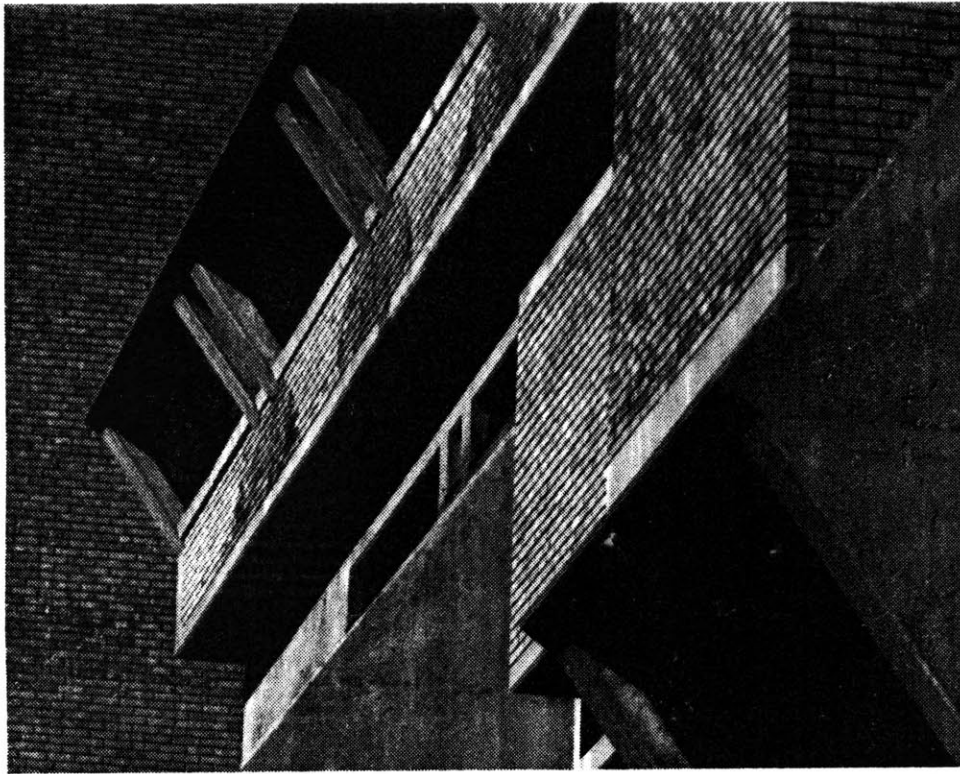

carrels have windows oriented parallel to the average noon altitude of the sun. Had the glass been vertical, objects in the foreground would have been seen only in silhouette. Because the sloped roof blocks the direct rays from view, the garden in front of and below the carrels is ideally illuminated.

The most comfortable lighting scheme in plan seems to be that in which an object in front of the viewer is lit from one side. At Goddard Library, the sectional relationship is analogous to the more familiar one in plan.

In alpine regions, "the sun bounces back off the snow and into the windows with almost the same intensity as when it comes directly from the sky." This has traditionally been considered a problem. In the summit house, reflections off the snow and off its shiny metal roofs can be directed into the upper-storey sleeping rooms through

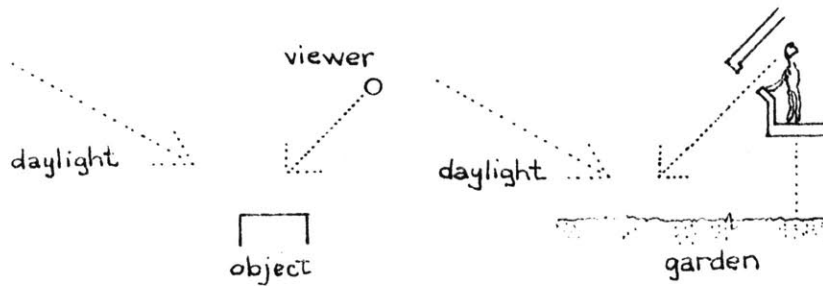

18 PLAN of typical state

SECTION at Goddard Lib.

glass tilted outward at its top.
Overnight visitors will be able to watch the movement of skiers near the main entrance from their rooms.

In general, window openings which are perpendicular to the landscape they frame offer the best long-distance views. At the summit house, northeast-facing windows should be tilted slightly outward at their heads to allow grazing views over the ski trails below. Views along the contours, in this case to the southwest, should be framed by vertical window openings.

The building section must respond to the variable qualities of daylight and views. The great night-time heat-loss potential of even triple-glazing, combined with the difficulty and expense of heating such an inaccessible facility require that small windows be provided except in those locations where direct gain can be used to advantage. *Glazing will not be per-*

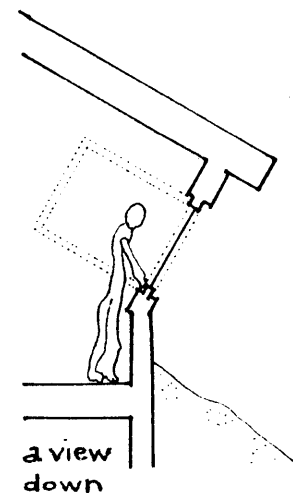
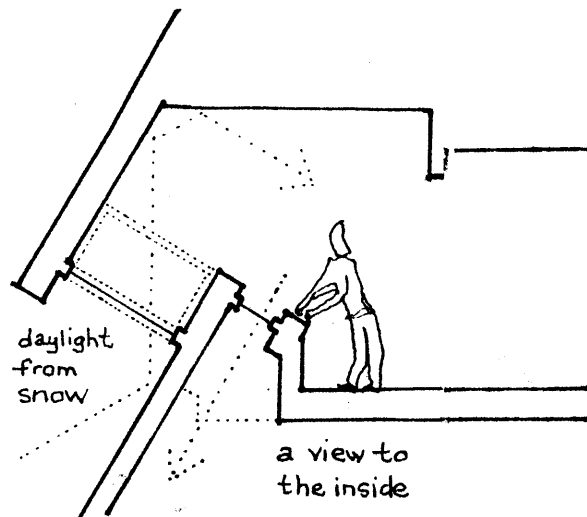

mitted unless it is oriented to optimize either exterior views, natural lighting conditions, solar gain, or a combination of these features.

Adjustable sun-control devices are critical for all interior spaces which are to be inhabited at times when exposure to the direct rays of the sun is likely. The shallow sun angles to the east and west must be handled differently, for example, from the higher angles of solar



Adjustable Devices

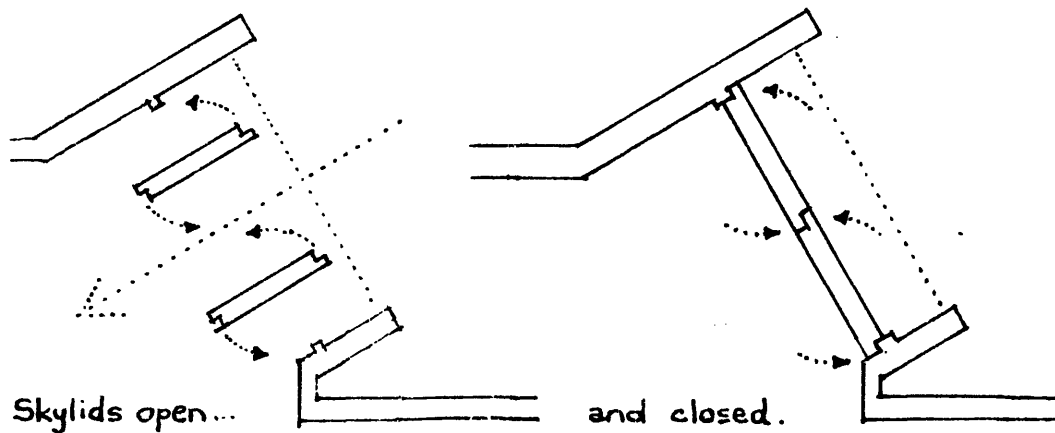

noon. Two extreme attitudes toward control are possible. The vertical louvers at Sert's Peabody Terrace Apartments can be rotated manually to reduce glare. The insulated horizontal louvers under the skylights at the Pitkin County Airport at Aspen operate automatically. At night and on cloudy days, these patented Skylids stay closed. Intense solar radiation vaporizes Freon stored within them. As it turns to gas, the Freon upsets the delicate balance of the louvers, which tip

open as a result. When sunlight is capable of heating the built environment, the skylids are open. When it is not, the lids close, and heat loss is reduced.

On the south side of the summit house, glazing for direct solar gain must be oriented differently from glazing for exterior views. Skylids should be placed between the two layers of glazing on the steep roofs. When the lids are closed, the roofs will be quite well insulated. In summer, they might be kept closed most of the time. When they are open, the sunlight will be able to reach the inside of the building.

All walls must be thought of as three-component systems. The functions of weatherproofing, insulation and interior thermal tempering should be built of identifiable and separable materials. The distances between the components will depend on the uses to be accommodated. Between the first and second layers

is a potentially habitable, dry, unheated space. Between the second and third is a heated space of low thermal mass.

The Trombe wall is an example of a gentle conceptual push in the right direction. A high-mass, high-absorption material is placed behind a south-facing glass wall, creating a continuous vertical air space. As the wall surface heats up, a convection loop is established. Cool room air is heated as it passes in front of the wall. If the glazing and the mass-wall are pulled farther apart, the dominant mode of heat transfer between the wall and the air changes from conduction to radiation, and the space between them becomes habitable.

The benefits to be derived from the separability of roof components are similar to those to be derived from the separability of wall components. The primary roof functions in an alpine setting are the

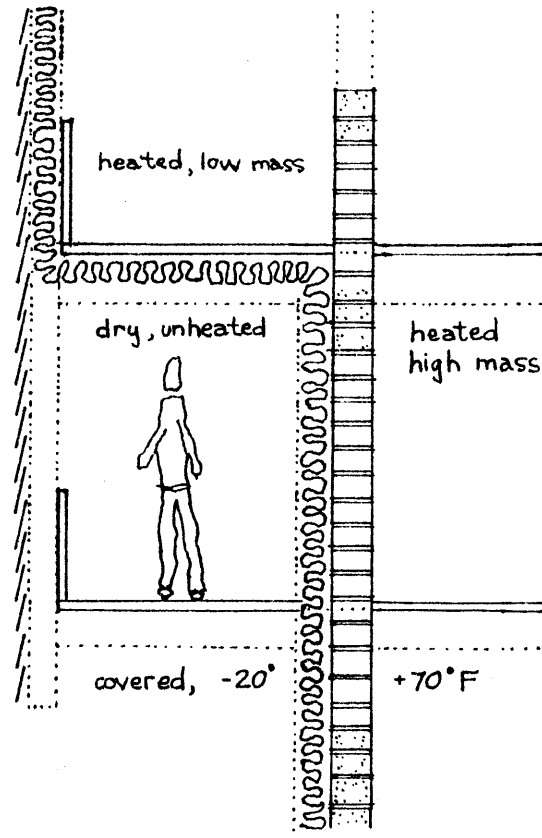

provision of a snow-bearing surface, a drainage surface, and a place for insulation. There are two potentially habitable intermediate spaces in a roof. Between the snow-bearing surface and the waterproof membrane is a partially covered outdoor space. The space under the membrane

Thermal Zones

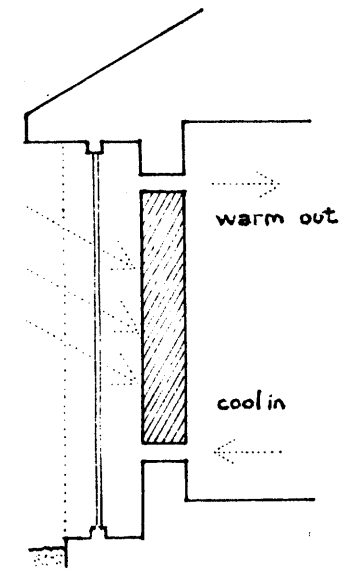



is out of the weather, but unheated, and could be continuous with the unheated indoor space between wall components.

In traditional alpine construction, there were three distinct thermal zones within the height of each house. The animals occupied the lowest level. Heat generated by them and the decomposition of their wastes rose to warm the floor of the spaces occupied by the family. The second-floor ceilings were insulated by the loosely-stacked feed grains resting on the attic floor. Whereas the lower levels

were sealed or sealable against the weather, the gable ends were generously ventilated. Besides helping to dry the feed, the cool air kept the roof cool.

A cold roof is one in which the cavity between the snow-bearing surface and the roof insulation is ventilated with cold outside air. A cold roof is not prone to ice-damming because the snow on top of it is maintained in its solid state. The snowmelt from warm roofs quickly refreezes at the eaves. Many believe that the problems resulting from these ice dams are more than offset by the insulating value of the snow on an unventilated roof. Few realize how low is the insulating potential of snow.

Snow's effectiveness as an insulator is directly proportional to its thickness, all else being equal. In order for it to act as an insulator on an unventilated roof, it must retain at least some of its thick-

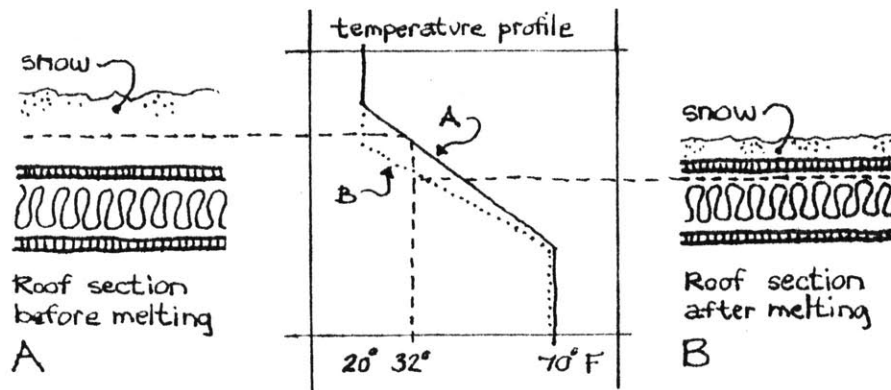

ness. If it is 70°F inside the building and 20°F outside, and assuming that the snow is as deep as the roof insulation and of equivalent insulating value, the net heat flow out through the roof will melt some of the snow. Not until freezing occurs below the surface of the roof will the melting stop. Only at this time will the snow be able to act as an insulator.

On a cold roof, snow will not melt from below. Ventilation under the roof deck, however, will render the snowpack useless as an insulator since the ventilating air will be at the outside ambient temperature. If it were possible to introduce ventilation at exactly 32°F, the snow snowpack would stay frozen and the insulation would only have to resist a design temperature of 32°F. There would still be a net heat flow to the outside, though, so energy would have to be expended to maintain a stable temperature in the cavity

between the roof layers.

A double roof is a cold roof in which the functions of snow-bearing and drainage have been physically separated. All the buildings at Avoriaz, a new resort in the French Alps, have double roofs. The uppermost surface is built with spaced square-edge planks and is supported on beams. These rest on brackets extending through the waterproof membrane below. Snow rests on the top deck. Water from rain and melting snow falls through the cracks and is carried off by the waterproof membrane.

To protect the delicate ground below the roof edge from excessive erosion by water from the melting snowpack and from the extremely heavy rainfall characteristic of high elevations, gutters and downspouts are a necessity. Unfortunately, large slabs of snow occasionally slide off the roof, endangering passersby, and taking gutters with

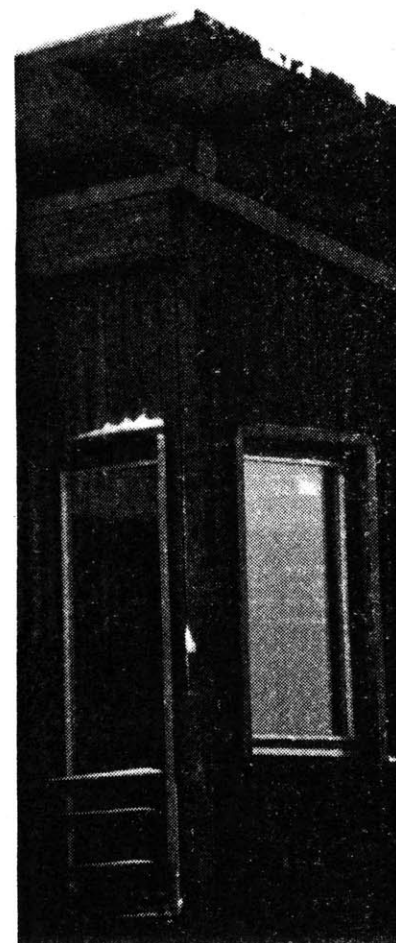

them as they fall.

The ambient air temperature must be above freezing for snow on the roof to melt and be carried to the gutters. These same temperatures will keep the water from freezing in the gutters. *By holding the edge of the drainage surface back from the edge of the snow-bearing deck, falling snow can be kept clear of*

the gutter. Crochettes - metal hooks - installed at the upper roof edge will break up large slabs sliding off the roof, reducing the danger to people below.

Once the functions of snow-bearing and drainage are physically separated, their forms can better define their potential uses. The membrane must still be sloped in order to drain. However, since the deck does not serve as a drainage surface, walking on it will do no harm. Therefore, the deck should be horizontal so that people can use it for outdoor activities.

At the altitude of four thousand feet where the summit house will be located, ninety percent of the nights and perhaps seventy-five percent of the days will require some heating. What is needed, therefore, is a building method which defines the differences between interior and exterior thermal zones, by taking advantage of the daily and seasonal

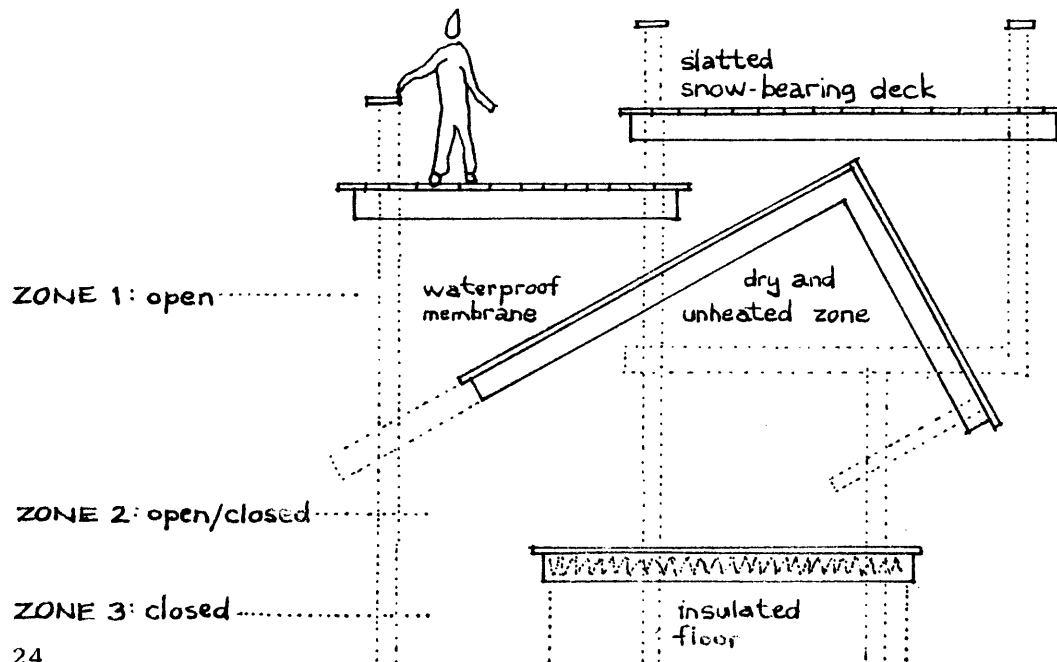

variations in solar insolation.

Ralph Knowles is sure that the Indians of the Acoma Pueblo in New Mexico realized this long ago:

Since the summer sun is more direct upon horizontal surfaces and the winter sun is more direct upon the south-facing walls... it would have been most reasonable if the vertical walls receiving winter sun had a high transmission coefficient and a high heat storage capacity. Conversely, the horizontals receiving their maximum energy in the summer should exhibit a low thermal transmission coefficient and a low heat storage capacity. A comparison of the materials used by the Indians reveals this to be the case.

Knowles, p. 31.

The reflectance of materials must become part of the thermal vocabulary. Surfaces sunstruck in

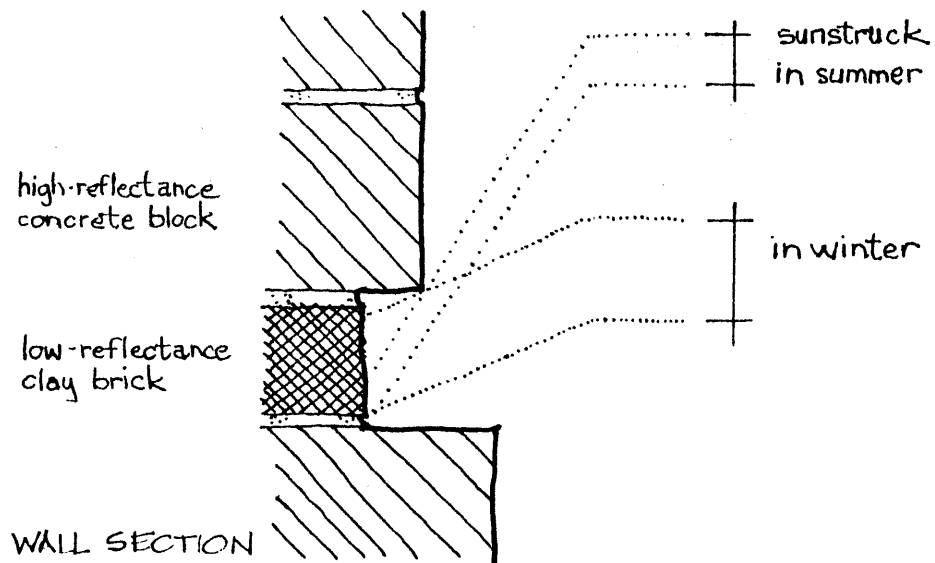

winter should be built of high-mass, low-reflectance materials, such as red brick. Higher-reflectance masonry blocks should be corbelled out so that they shade the bricks in summer, when less heat storage is desired. The high ambient air temperature of a summer day will still cause the bricks to warm up, but at only one quarter the rate that would result from direct gain.

The comfort of the inhabitants relies heavily on the thermal mass

Materials

sun for everyone: synthetic
skiing surface required

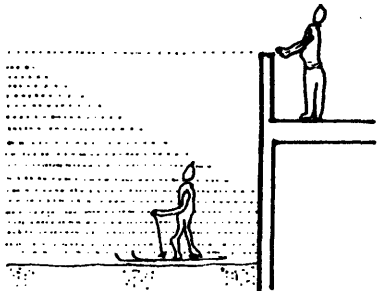
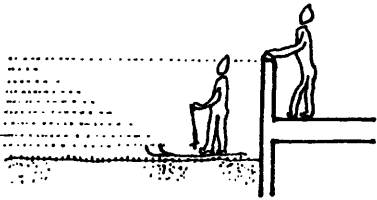

sun for bystanders only: real
snow will survive

Banham, p. 117.

and the radiant temperature of interior wall components. The chill felt near windows on cold winter nights and the cool of a concrete basement in summer are two familiar examples. In both cases, the mean radiant temperatures of the surrounding materials are much different from the ambient air temperatures.

Frank Lloyd Wright used this contrast to his advantage in the Robie House. The masonry walls and roof were extended far beyond the weatherskin of the house.

...The first environmental feature of the house strikes the summer visitor even before he is through the door - the coolness of the shaded entrance court. It lies on the north side of the house and receives practically no sun. Unfortunately, the architect doesn't seem to have considered how uncomfortable his cool-air trap might be

in winter.

Built forms must be sympathetic with the different natural forces dominant in each season. Aspects of the program needn't conflict with one another as a result. Separation of the forms which define conflicting uses is the proper response.

The landscape is often at its most magnificent when the air temperatures are near their lowest levels. The heat desired by the winter visitor sitting outside, however, will melt the snow he needs in order to ski. This problem has two categories of solutions.

The first involves trying to get sun and slippery surfaces to co-exist. Once a little ground shows on the ski trails, heat is absorbed by it and conducted to adjacent material. The snowpack melts from below. The melting rate of snow in direct sunlight can be kept to a minimum, therefore, if surrounding surfaces have reflectances almost as

high as its own. Another alternative involves covering the ground in the sun with the commercially-available toothed synthetic mats over which skis can slide. The presence of this material will allow skiers approaching the building to enjoy the sun without having to remove their skis, even if there is no snow underfoot. The teeth which project from the mats are very sharp, however, and make falling particularly uncomfortable.

The second class of solutions advocates the separation of these functions. Because the ambient air temperature in the morning is very low, sunlight at that time will not be as destructive to the snowpack as it will be later in the day. *The winter-time entrance court should be oriented to the southeast in order that arriving skiers have the benefit of solar heat in the early morning when they need it most.* Placing outdoor sitting places at

the same height as roofs further to their west will expose them to the warm afternoon sun. The shadows cast by the building at that time will keep the snow in the court from melting.

Thermally-tempered interior zones must distinguish not only between periods of use (morning, afternoon, or evening), but between frequencies of use. The manager's office at the summit house is liable to be occupied intermittently throughout the day. Its mean radiant temperature should be kept sufficiently high that it will be comfortable whenever it is entered, even if its ambient air temperature is allowed to drop when the room is unoccupied. Bathrooms serving the skiing public will get the great majority of their use during the day. Since it makes little sense to store their heat overnight, and would require great thermal mass, they should be lined with a low-mass

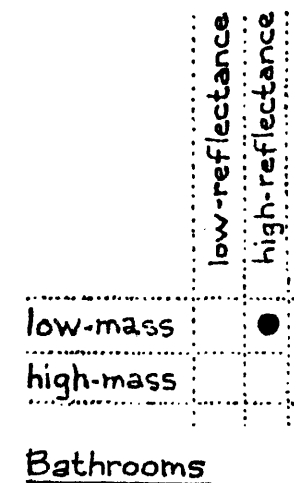
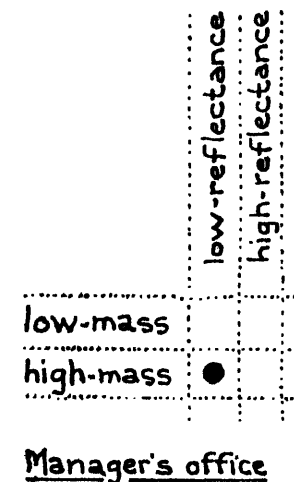

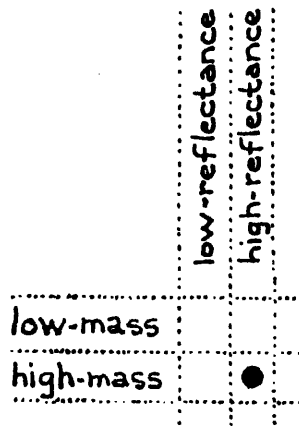

Plumbing chases

material and warmed with local space-heaters. The plumbing, however, should be contained in a high-mass compartment. The thermal stability of the space will delay freezing of the pipes in case of failure of the heating system.

The expansion and contraction of construction materials with changes in temperature should be

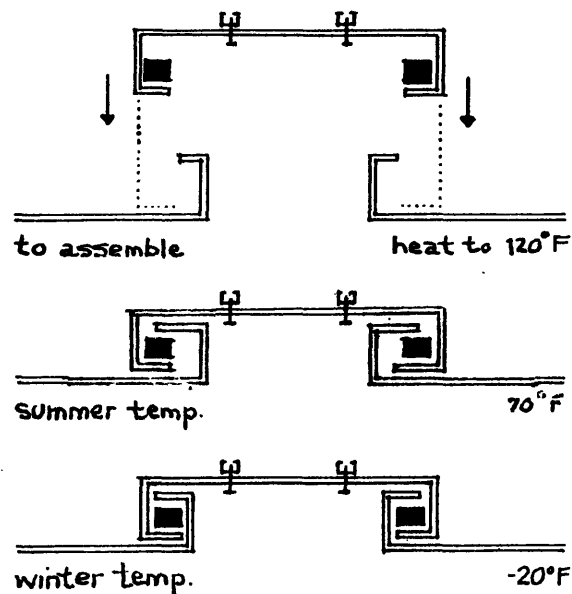

Floating metal panels engage fixed channel and compress neoprene strip as temperature drops.

considered a design opportunity, not a problem. Since infiltration and moisture migration are at their worst at low temperatures, the goal should be a weatherskin which gets tighter as the temperature drops.

Metal panel systems in which adjacent pieces are simply butt-jointed and caulked are unable to operate this way. A system is proposed in which adjacent panels lock into one another, with a compressible strip between. A high-reflectance surface is required so that the majority of thermal movement of the panel results from variations in the ambient air temperature, not from changes in the radiant solar temperature.

Much less heat is available outside on many winter days than is required for the comfort of stationary individuals in the sun. Because of the greenhouse effect, much more heat is available during a sunny winter day inside than is desired.

How can the radiant heat from the sun be distributed more equitably?

Outside, the sun's rays must be concentrated. At the Yokum Lodge in Aspen, Colorado, architect James Lambeth designed a faceted parabolic mirror intended to address this problem: "...twelve feet of snowfall is fine for skiing, but how do you get to the front door?" The mirror melts accumulations of snow at the entry. It is a device which must be used to create thermally tempered exterior spaces at the summit house.

Inside, the sun's rays must be redirected. At M.I.T.'s Solar House 5, parabolic venetian blinds focus sunlight on ceiling panels loaded with phase-change salts. As the heat is absorbed, the salts liquify. When the ambient temperature drops below 78°F, the stored heat is radiated, and the salts solidify. It might be possible for one device to serve the functions of both the Skylids and the blinds.

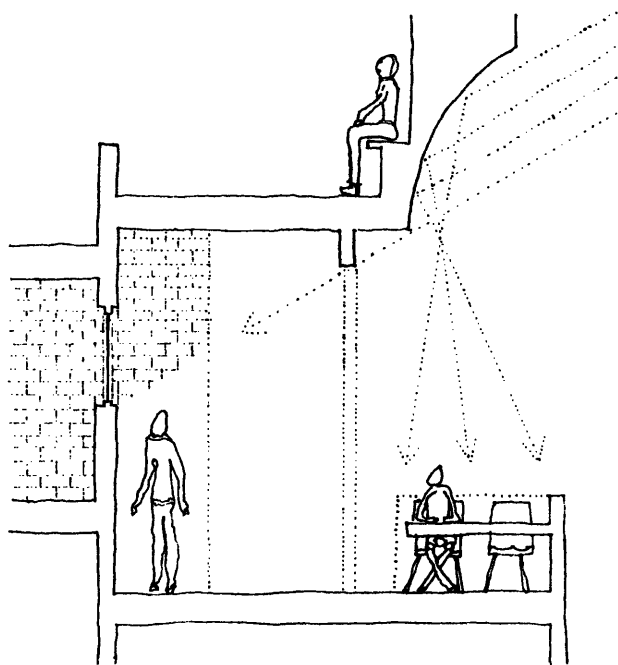

Lambeth, p. 84.

The summit house must incorporate advanced solar collection systems. The overnight accommodations should be located above the public spaces subject to the greatest direct winter solar gain. The plane of the phase-change tiles in the ceiling should be tilted slightly and be mounted behind a sealed layer of glass. The result will be a series of almost-

Transformations

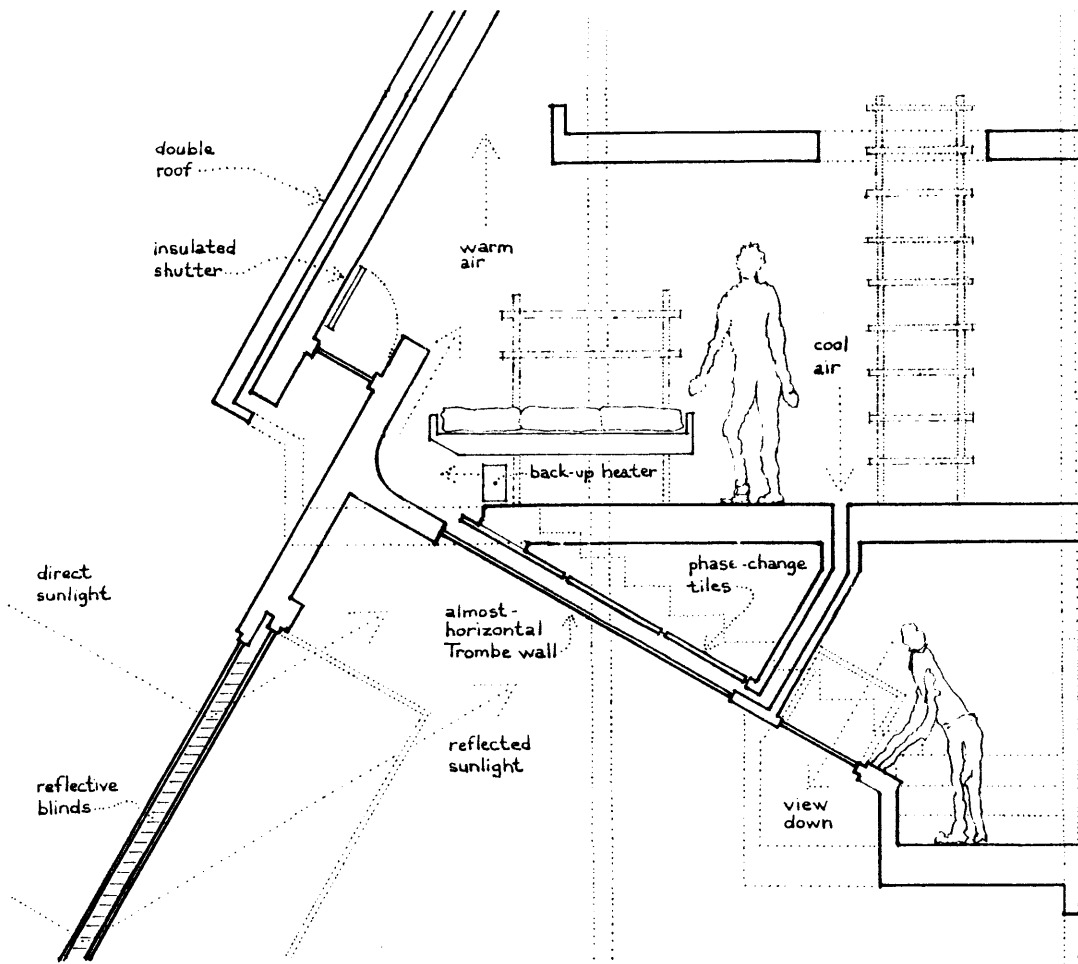

horizontal Trombe walls which will only operate when overnight visitors open vents in the floors of their rooms. The natural convection loops established by the warm tiles and the cool ceiling will help warm the bedrooms.

The Wind

The mountain winds, like the dew and rain, sunshine and snow, are measured and bestowed with love on the forests to develop their strength and beauty. However restricted the scope of other forest influences, that of the winds is universal...

John Muir

Fluid Grain

Fluid grain describes the orientation and texture which materials acquire from exposure to fluid flow. Plants submerged in a river or stream point in the direction of the fluid flow. The lateral growth of alpine groundcover to minimize exposure to wind and to assure protective and complete burial in winter snows is an evolutionary response to wind flow. In pre-industrial societies, fluid grain was considered in the construction of watercraft:

McPhee, J.: The Survival..., p.28.

The bark of a birchbark canoe is always inside out. The side that touched the wood of the tree is the side that touches the river. Rind clings only to bark that is taken in winter. There was a practical function in the designs the Indians scraped into it. The designs were a way to indicate the bow and the stern. Birchbark canoes are not...reversible, because where one piece of bark is sewn to another there is a slight overlap, and the overlap faces the stern, so the seams will not be torn open when the canoe scrapes over a rock.

Whenever an object moves relative to a fluid, fluid grain will manifest itself or should be built into the object. The canoe moves

relative to the water. Its grain is built into its hull. The mountain-top winds move relative to the summit house, and suggest that its closure have grain.

Since wind forces will often be nearly as great as those of gravity, precipitation will most likely fall diagonally along certain parts of the weatherskin. To prevent the passage of water through the weatherskin, the cladding must be installed in response to local wind patterns around the building.

Wind poses the most challenging environmental problems at the alpine summit. The inherent mass and shear-resistance of the materials used in traditional stone construction obviated supplemental lateral bracing. Because buildings today use so little and such light material, it has become necessary to incorporate additional wind resist-

ance in the form of shear walls or diagonal braces. Similarly, achievement of the goal of greater energy-efficiency has required, among other things, the installation of additional infiltration resistance, usually in the form of weatherstripping. The amount of stiffness and weather-tightness required is related to the speed and direction of the wind.

Increases in altitude are accompanied by higher windspeeds and reduced directional predictability. Although they can blow from any quarter, the strongest winds come from one direction. *On the site of the summit house, the prevailing winter winds come from the northwest.*

Snow drifts are a three-dimensional manifestation of the directions and velocities of the wind. In the calm air of the Alps, the



Natural Forms

consistency of the depth of the snowpack from place to place has led to the development of a lifestyle in which pedestrian and vehicular movement proceeds along the surface of whatever ground is available. Because the snow and ice of the winter-ground are more slippery than the bare earth and paved roads of summer, life there is easier in some ways in winter than in summer. Young children, for instance, can be pulled along in sleds rather than carried in their parents' arms. The situation changes dramatically, however, when strong winds are present. The inconsistencies in the depth and load-bearing capacity of the drifted snowpack make working with it a difficult problem.

Perla, p. 27.

Due to pulverization, the average size of the blowing snow particles may be only one-tenth the size of those that fall undisturbed.

Because of small particle

size, wind-deposited snow is two to four times denser than snow that falls in a sheltered study plot.

The capacity of moving air to carry snow is a function of its distance from the ground, its speed, and the moisture content of the snow it is carrying. The great majority of drifting results from transport within two meters of the ground. The volume of transported snow varies as the third power of the windspeed. Wet snow is deposited more heavily on the windward side of an obstacle during very light winds than on its lee side. In general, however, the greatest snow deposition occurs where windspeed is decreasing, such as on the leeward side of terrain irregularities.

Snow drifts form by a cumulative process. The total form is composed of a multitude of thin layers, each shifted slightly beyond the one below it. The snow cornice is a fami-

liar result of this process.

As each layer accretes onto the roof, it tends to extend out over the cornice face, supported as a cantilever sheet. After attachment to the roof, the layers are deformed slowly by gravity and bend toward the cornice face as a curved tongue that often encloses an airspace.

Cyclical changes in temperature and humidity slow the homogenization of the deposited layers. The density gradient bears striking resemblance to that found in the rings of a tree cross-section. The snow layers are a temporary record of daily climatic variation, while the tree rings are a permanent record of seasonal climatic variation.

The closely-spaced vertical slats at the eaves of Himalayan houses are a permanent record of seasonal climatic variation.

Although their primary purpose is to

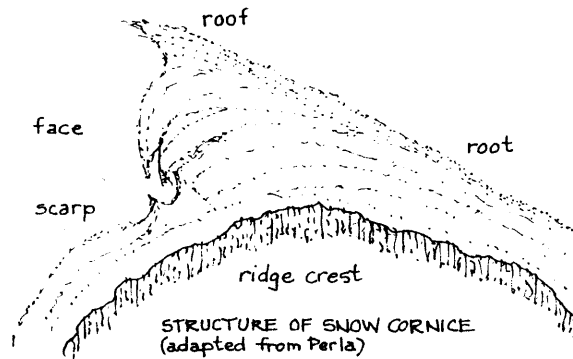

Perla, p. 25.

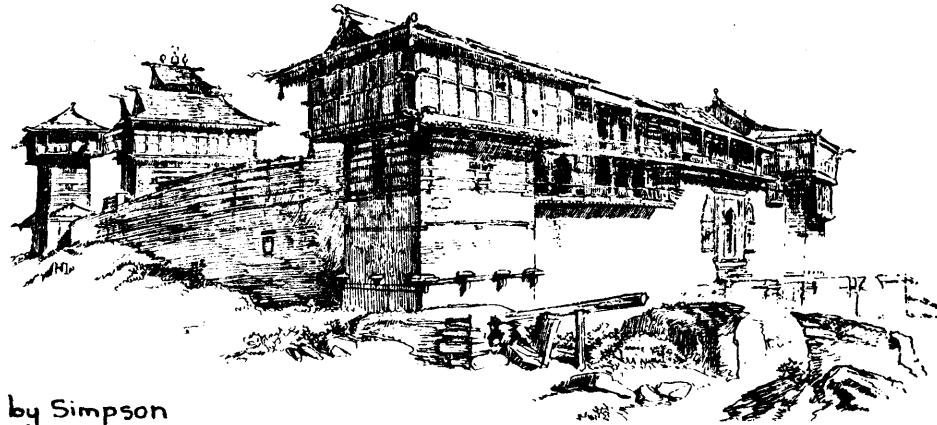

by Simpson

shade the exterior walls and balconies, they refer quite literally to the icicles which form near and around them in winter.

Simpson, p. 77.

If cornices were allowed to grow above south-facing windows at the summit house, they would find several uses, too. The problem, of

course, is that the potential for overheating of the interior is much higher in summer, after the snow has gone, than in winter. A cornice-like form can be built in the location where it would form naturally. And, like the real cornice, it will have a potentially habitable space under its tongue. The overhanging roof will provide shade in summer. In winter, it will keep icicles far enough out from the building that they will not endanger glazed roof surfaces when they fall.

If the wind direction is fairly constant, the designer can modify drift locations in predictable ways by building various irregularities

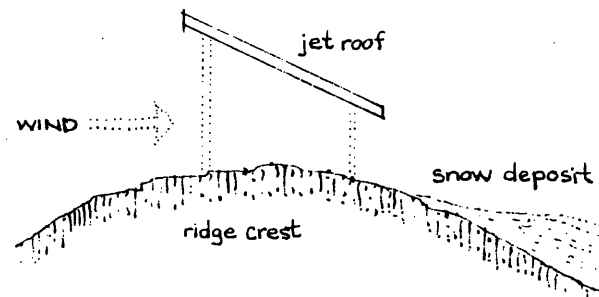

into the terrain. A number of forms have have been developed to set up to set up local differences in areas of otherwise constant air pressure. Because scouring occurs in zones of high pressure and deposition in zones of low, a snow fence on the windward side of a road can keep it clear only if adequate clearance is kept between the fence and the road for drifts to build. Jet roofs operate by accelerating the wind, thus keeping the area immediately behind them free of snow. Because of the direct correlation between the pressure and speed of flowing air, wind which passes under the higher side of a jet roof must leave the low side at higher speed, and with greater snow-carrying capacity. Whereas the snow fence will cause snow deposition in its general area for winds from either side, the jet roof is obviously effective only for winds approaching nearly perpendicular to its high side. It is import-

ant to remember, therefore, that winds from some directions will lead to undesirable deposition patterns. *Alternatively, the built forms might be designed to prevent the passage of wind coming from undesirable directions.*

What precedents exist for this sort of device? Gray's Anatomy describes the mechanism in the human body which deals with backflow:

On the surface of the valve next to the wall of the vein the cells are arranged transversely, while on the other surface, over which the current of blood flows, the cells are arranged longitudinally in the direction of the current.. if, however, any regurgitation takes place, the valves become distended, their opposed edges are brought into contact, and the current is interrupted.

The backflow dampers presently employed in hot-air solar collector

systems operate much this way, but on a very crude level. They have few moving parts, though, a distinct advantage if used as the model for such valves in alpine environments. The frequency and severity of the freeze-thaw cycles is likely to render all but the simplest mechanical devices inoperable in short order.

The characteristics of surfaces along which movement occurs must vary with the location of the flooring materials and the activities they must accommodate. People are liable to be wearing any of a number of types of footwear at a summit facility. For hiking, boots are required. For exclusively indoor use, sneakers may be worn. During a winter day, individuals will typically arrive at the building on skis, but enter it with only ski boots on their feet.

Because of the stiffness and lack of traction of ski boots, it is

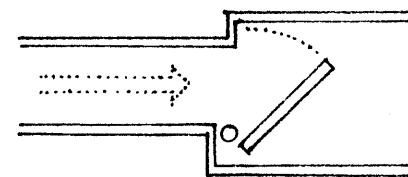

A spring-loaded door...

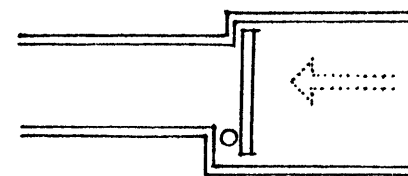

is all that it takes.

desirable to keep clear of snow those outdoor places where walking is expected in winter. Jet roofs should be oriented to cause scouring of exterior pedestrian zones. Snow fences should be installed as railings between walking and skiing surfaces to increase deposition where it is desired.

Directional Devices

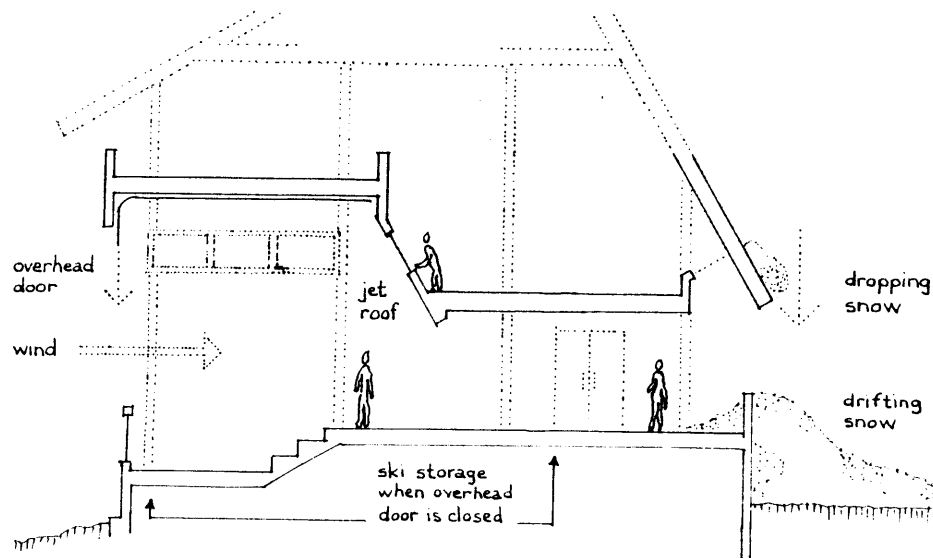

The space under and behind a jet roof must be large enough for human use. It will be clear of snow much of the time, but will be unusable when cold winds are blowing. If a door is provided on its higher side, the space can serve at least two purposes. For the eight hours of the day when a sheltered outdoor space is desired for leaving skis and poles before entering the building, the door can be kept closed. When the wind is blowing out of the northwest, and the skiers have made their final run down the mountain or moved inside the building for the night, the door can be opened. The wind will then be taking snow from places where it is not wanted and redistributing it where it will be of use.

Accumulated snow may move down-slope at either of two speeds. If the first snowfall of the season occurs before the ground has frozen, the underside of the snowpack will

slowly melt. The free water will act as a lubricant, allowing the snow to glide under the force of gravity, usually moving no more than a couple of feet a day. When large masses of snow move rapidly down-slope, however, an avalanche has occurred. Houses, transmission towers, and other objects in the path of glides or avalanches are often carried right along with the snow.

For centuries, people in the Alps have been building stone wedges on the uphill sides of their dwellings. In German, these wedges are called lawinen-keil. The English equivalent is avalanche-splitters. Sometimes each wedge protects a single home, as in Wengen, Switzerland. Sometimes, single wedges are used to protect entire villages, as in Zmut. Regardless of the speed with which the mass of snow approaches, the wedges deflect it from its original course. The great amount

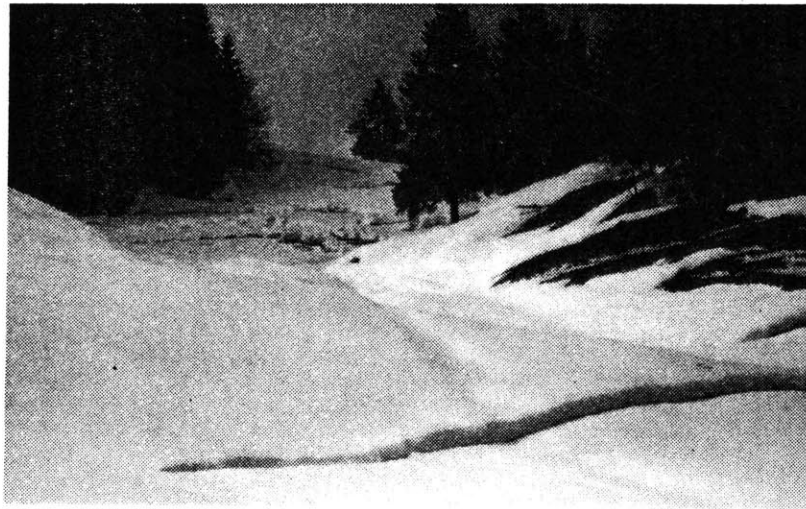

Redirectional Devices

of debris which is carried along by the sliding or gliding snow often includes many large stones. These are collected and used to build additional defense structures.

The mountains of New England are generally not subject to slides or glides. The great timber stands covering the flanks of the Green Mountains reduce the risk of avalanches by breaking up into small pieces the otherwise large slabs of

cohesive snow which slide frequently on unforested slopes elsewhere. Since the ground is usually at least partially frozen at the time of the first snowfall, glides are not a problem.

Although the wedge may not be of value at the summit station for resisting gravity-induced snow movement, it may be useful in efforts to use wind both to keep some surfaces clear for human use and to reinforce distinctions between the winter and summer entrances to the building. If oriented with its point toward the northwest, the wedge could deflect the strongest winds around the perimeter. The redirected wind flow could be put to use if the jet roof were built out from one side of the deflector. *By defining the deflector's other trailing edge so as to cause air turbulence, snow could be deposited intentionally in great enough quantities to prevent access in winter to the summer entrance.*

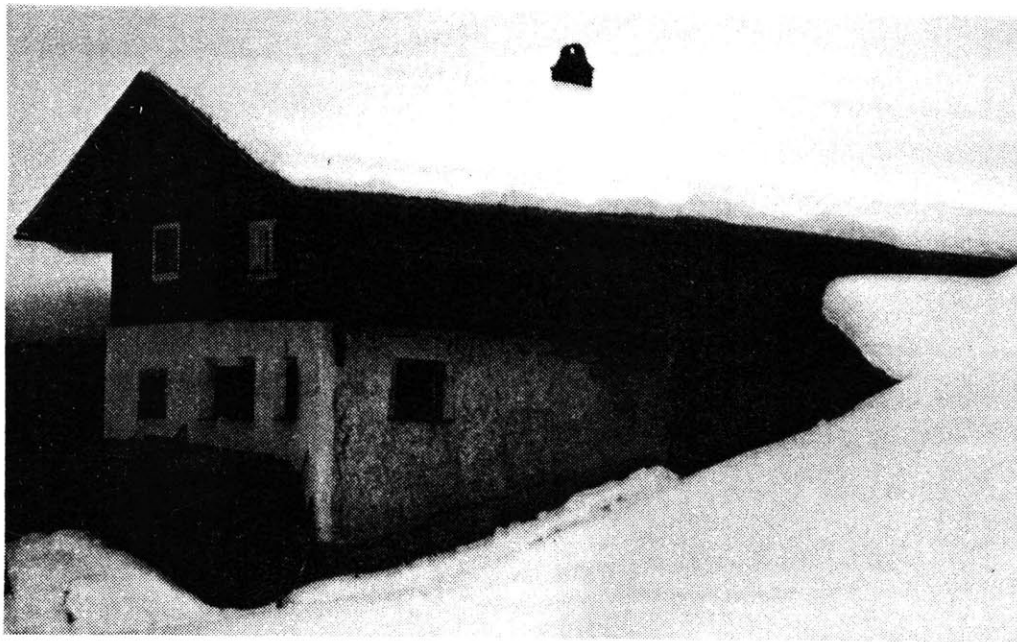

FORMS



The Ground

Ground Grain

John Wesley Powell

The mountains were not thrust up as peaks, but a great block was slowly lifted, and from this the mountains were carved by the clouds -- patient artists, who take what time may be necessary for their work.

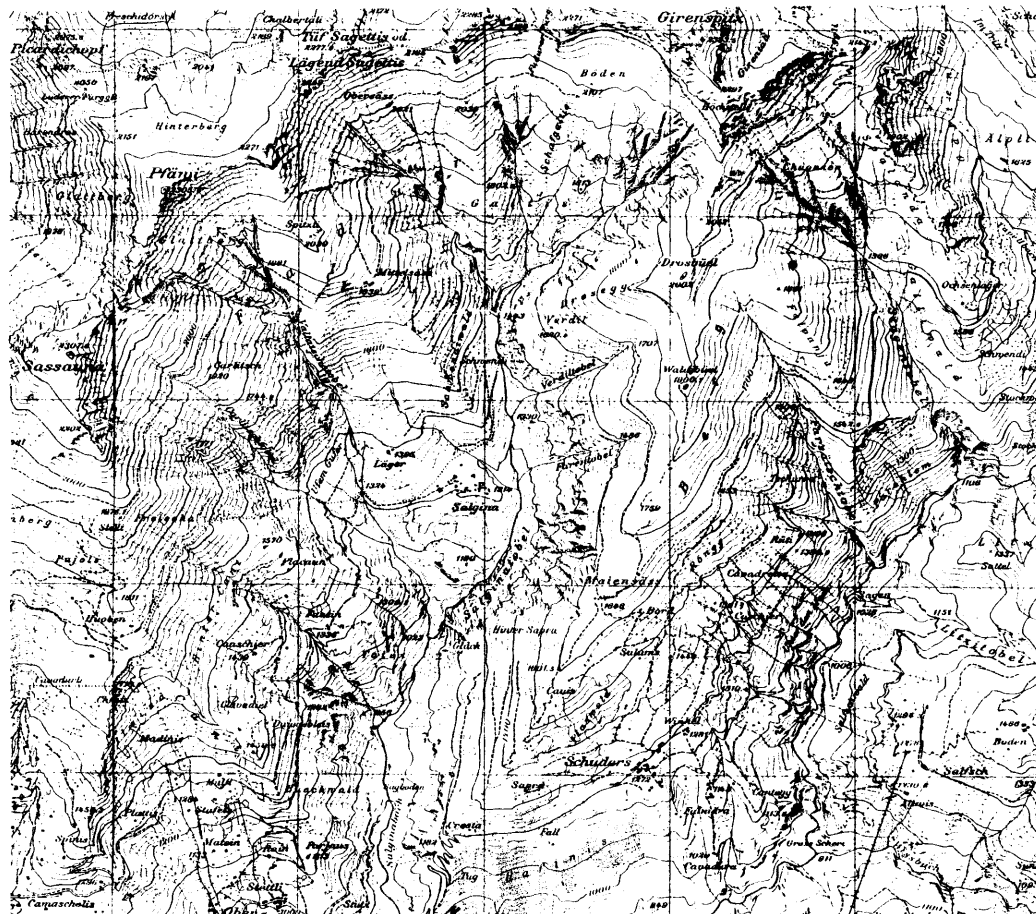

Ground grain refers primarily to the direction of the contours and the steepness of the slope. Because man cannot move with equal ease in all directions, ground grain influences patterns of use.

Walking with the contours requires little effort. To remain erect or to climb, however, man must resist the inexorable force of gravity. Movement through the mountains requires substantial changes of altitude. In what ways has this issue been addressed?

The topographic qualities of the Alps have led to the development of a highly territorial lifestyle which minimizes daily movement against the contours. Many villages lie at the foot of huge glacial cirques or bowls. As the snowline recedes in the spring, the shepherds and their flocks ascend to the fertile high-

elevation meadows. The landscape acts as a natural fence between the bowl belonging to one village and the one inhabited by the next.

The Swiss rail map describes the topography of the country, even though no contour lines are drawn on it. The strict limitations on the steepness of grade that trains can climb has resulted in a transportation system which moves along the valleys between mountain ranges. In general, movement over the mountains is avoided. Tunneling is preferred.

In general, man climbs by traversing the landscape between switchbacks. The angle, in plan, between that path and the actual fall line is primarily a function of the steepness of the slope. In extreme cases, the overall movement in the mountains runs nearly perpen-

dicular to the local movement.

Man can climb steep terrain more directly than most of his vehicles, but the stresses he induces in his Achilles tendons by doing so can be uncomfortable or even damaging. One manufacturer of mountaineering ski bindings has introduced a model which keeps the climber's foot in a horizontal position while holding the ski on the steep slope below. The system allows a reasonably normal gait on abnormally steep terrain.

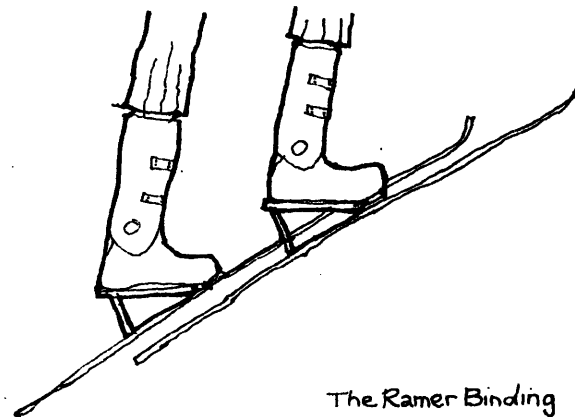

The Ramer Binding

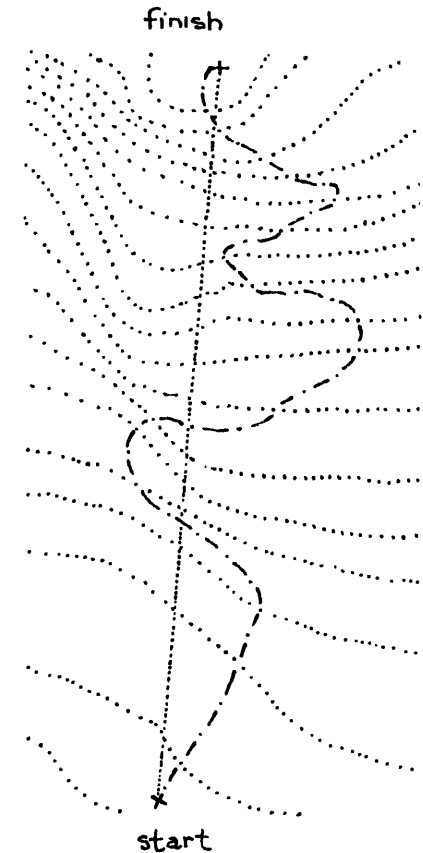

..... overall movement
 --- local movement
 contours

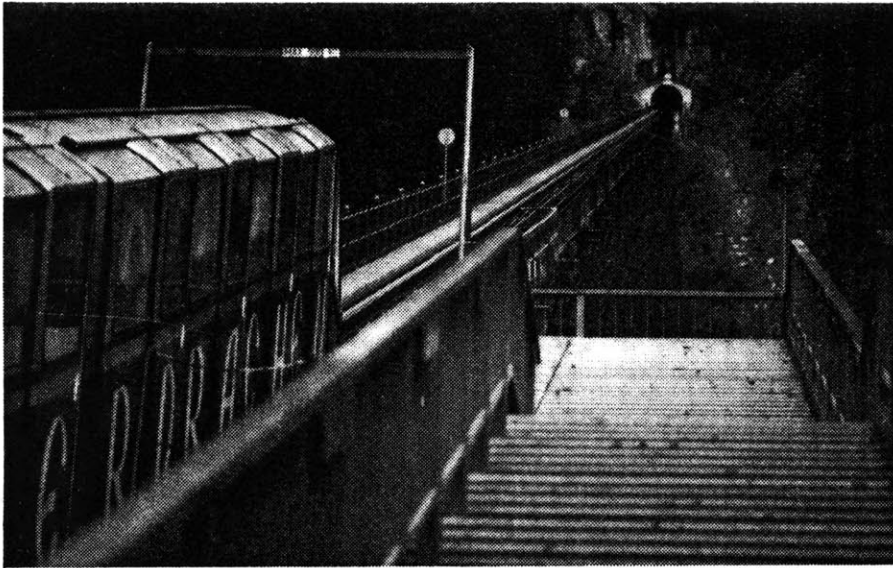

At least one mechanized mountain climbing system, the funicular railway, has maintained the distinctions between comfortable slopes for human use and actual mountain slopes. Funicular railways consist of two cars, one initially at the top station, the other at the bottom. Because they are connected by a cable, the ascension of one car causes the other to descend. Since the cars themselves are of identical weight,

energy is only expended to move people and cargo up or down and to overcome friction in the system. The passenger compartments are each about eight feet long and the width of the car, and are aligned with unloading platforms at the stations. The people use only horizontal surfaces, but the train sees only sloping track.

For the less steep slopes climbed by cog railways, a slightly different solution exists. For safety and comfort, the track at the stations is horizontal, as are the floors in the aisles and near the doors. The floors of the seating areas are built at an angle with respect to the aisle, but are actually horizontal when the train is climbing. The seats are oriented to the ascending attitude of the floors under them. When a floor surface is likely to be in use, it is horizontal.

All of the examples discussed above dealt with the differences between moving horizontally and climbing. Differences between going up and coming down were traditionally accommodated by sealskins attached to the bottoms of one's nordic skis. The grain of the fur, like that of the plastic fish-scale bases available today, allowed sliding in only the forward direction, regardless of the character of the snow underfoot.

The depth of snow at any location is constantly changing. To understand the ways in which exchanges between variable-ground and fixed-ground can be made, three models are proposed. All originate at ocean-side locations, where the height of the water varies with the tides.

The first and most common solution is the floating dock. It is a hinged extension of the real ground.

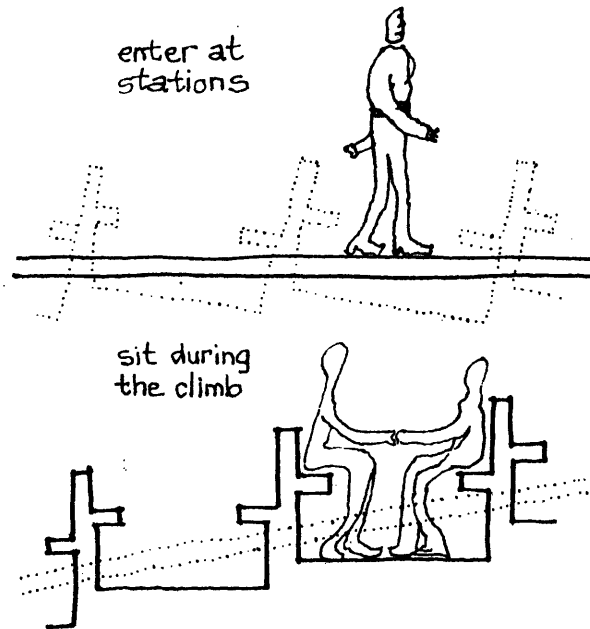

Analogous mechanisms are in use in snow country. The hotel at Lago Nero, in the Italian Alps, for instance, has a staircase hinged to its terrace. The bottom of the stair is supported so as to always be even with the snow surface. Because objects in snow don't float to the surface as they do in water, the raising of the stair must be performed manually. Also, the flatter the stair gets, the more

Fixed Responses

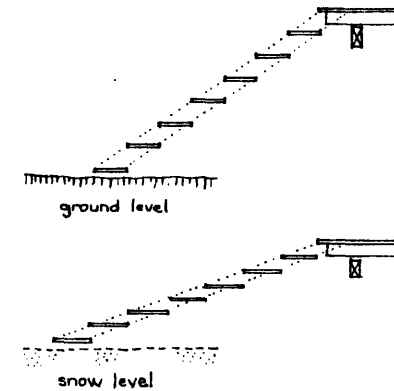

Careghini, p. 491.

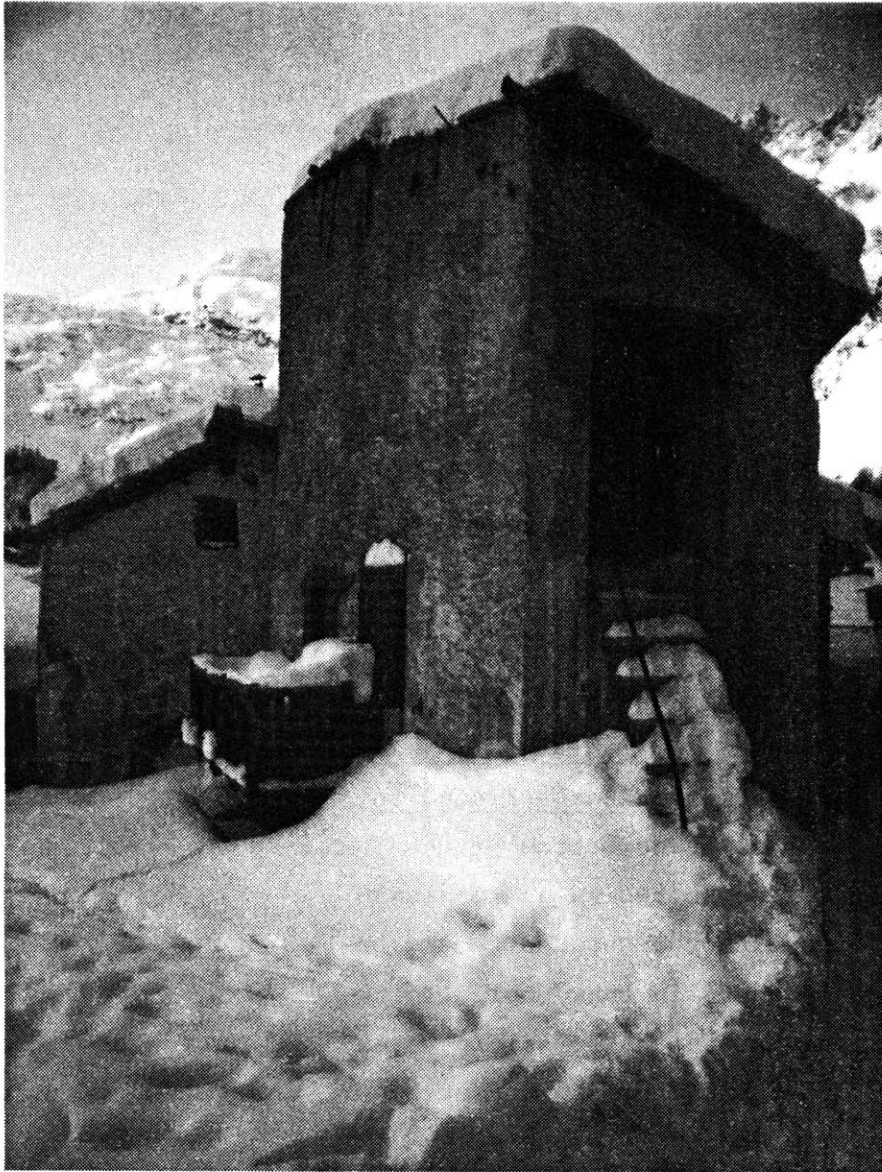

Adaptation

dangerous it will be to climb, particularly in ski boots.

The lift operators at Snowbird, Utah sit in closet-sized buildings mounted in tall wooden frames. A rope runs through the roof of each building, over a pulley on the outside frame, and back to a point of attachment on the roof. As the snow depth increases, the operator hoists up his shelter. In regions of immense accumulations of snow, this type of solution seems unavoidable.

The second ocean-side relationship is the fixed stair. Its top landing is just above high tide, and its bottom is just below the low-water mark. As at the ocean, the use of fixed stairs in the mountains provides a visual reference to the absolute fluid level.

Milestones in water level are visible in a canal and lock system. Passage from one body of water to another is handled by an intermediary compartment, whose water level

can vary. The level of the Charles River lock, for example, must match the harbor level for boats to enter, and must match the river level before the gates can be opened for boats to leave.

In the mountains, then, the third method of dealing with variable snow levels involves placement of a series of low walls adjacent to the summit house. The height of each wall would be related to the approximate snow depth that the trail behind it required in order to be skiable. Once the wall was buried, access to the trail would be direct.

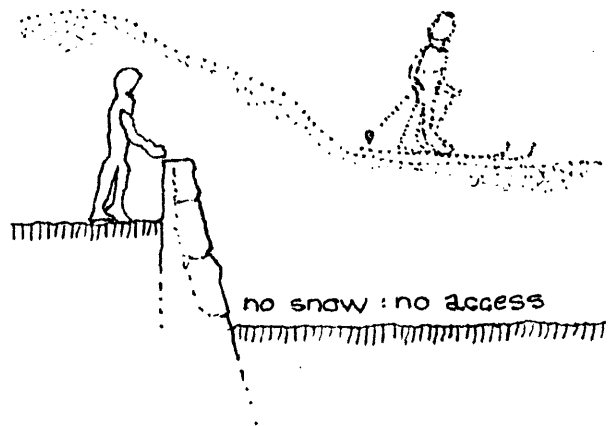

Access to the trail system is by ski lift. Three types of ski lifts are in general operation. The first requires that ski equipment be removed before loading. The second allows the skier to keep his skis on, but lifts him above the snow surface. The third requires that he leave his equipment on, for it pulls him up the hill along the snow.

Gondolas, trams, and ski trains compose the first group. The capacity of a gondola car is usually four persons, while that of a tram or train can reach over one hundred. Ski trains are more involved with the landscape than the others because they never leave the ground. Unable to climb steep slopes directly, they typically follow circuitous routes through the snowfields. Unfortunately, the qualitative differences between the train ride up and the skiing route down are thereby diminished.

Chairlifts compose the majority

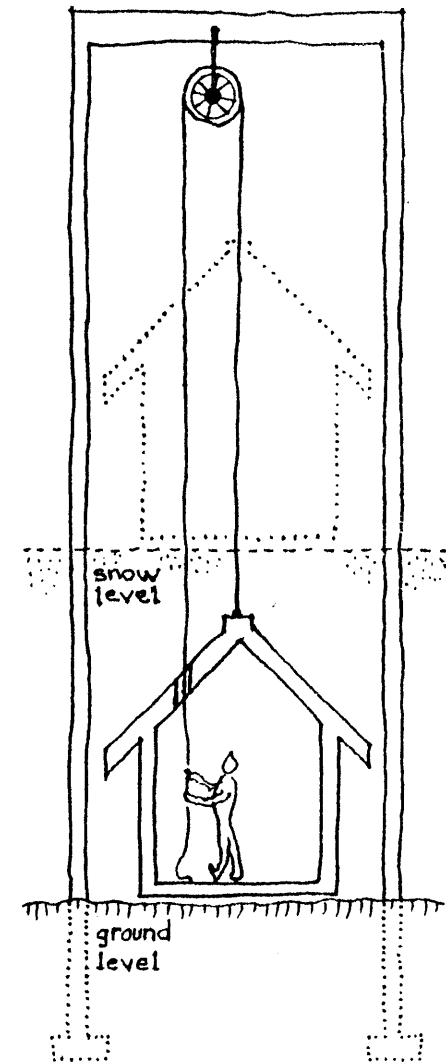



Barry, p. 726.

of the second category. They generally have only one destination. Reaching it requires its rider to sit in chairs suspended in space. Many dislike this experience, particularly on windy days.

Surface lifts compose the third category. The rider can terminate his journey at any time simply by releasing the moving metal or plastic seat on which he is sitting. These lifts are low enough to the ground that the surrounding trees shield them from all but the heaviest winds. Because of the lateral fixity provided by the skier's stance on the snow, lift operation can be continuous on even the windiest days. Although surface lifts experience the greatest frequency of accidents, the severity of injuries occurring on lifts which carry their passengers off the ground is much greater. *"The T-bar...is inherently the safest design," and will be used to reach the summit house.*

The technology exists to build and operate surface lifts whose routes are polygonal in plan, rather than single straight lines. *Lift routes could then respond not only to the trail network, but to changes*

in topography, vegetation, and microclimate.

Until recently, surface lifts were the only type whose operating season matched the snow season. The advent of tracked turf skis has changed all that. *T-bars can now be ridden all year.*

In winter, although most people will be brought to the site by the ski lift, food and other essentials will be delivered by tracked snow vehicles equipped to carry cargo. Because their primary function is grooming of the slopes and trails, the facility they serve should be adjacent to a major ski trail. The greatest danger will then be that a skier rounding a turn might run into a snow vehicle approaching the building. The human and vehicular paths must split far enough from the



building that each party has a clear view of the other. *Since some winter-time guests may arrive by snow vehicle, their route up and into the building must join the other winter-time entry route.*

Association

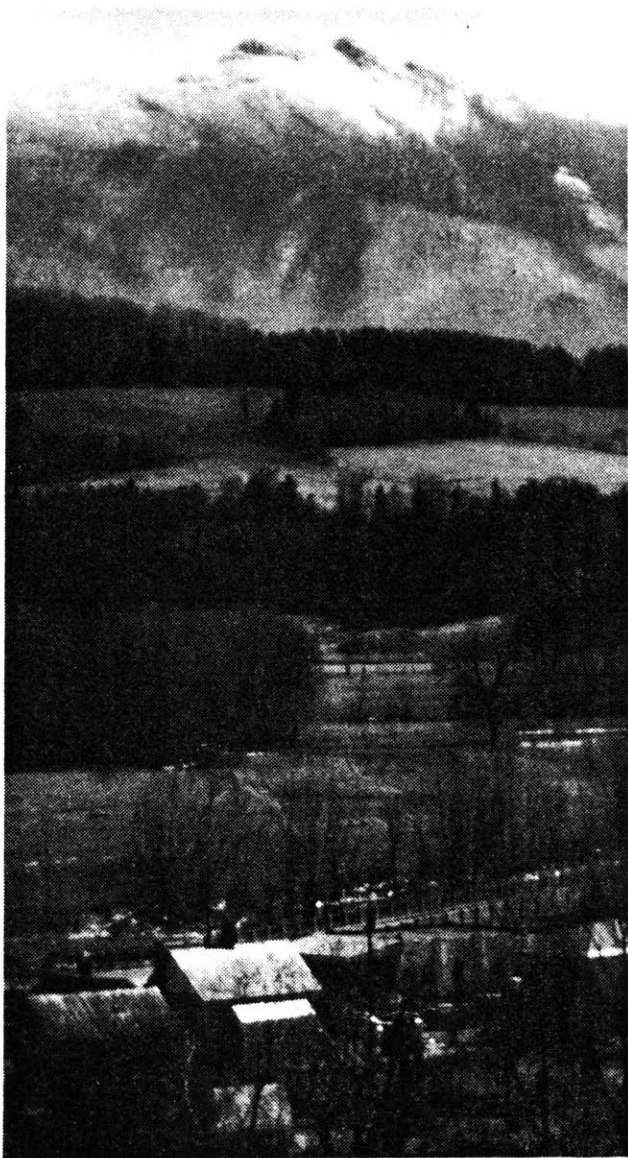

Cereghini, p. 31.

Natural Transitions

The Climate

The became disoriented with the loss of visibility in the rain or snow. Dressed only for warm conditions, they began to shiver in spite of the physical activity. Their strength began to drain away. Scared, they figured that they ought to stop and think, but there was little shelter among the rocks. Soon their fingers became too numb to open their packs or zip up their jackets, if they could get them on. Eventually, when they tried to stand up they fell. After coordination was lost, they became irrational. At this point the process became irreversible without outside help. You don't have to freeze to succumb.

Don't Die on the Mountain

The changes in temperature which accompany changes in altitude determine to a great extent what types of vegetation will thrive at each location on the mountain. Cereghini has isolated five climatic zones in the Alps, each occupying a horizontal band whose lower and upper limits

vary with orientation, latitude, and other factors. The lowest belt experiences a Mediterranean climate. Deciduous forest comprise the majority of the vegetation of the second belt. Fir trees predominate in the third. The fertile pastures which occur above three-line give way to rock faces which terminate at the summit. By contrast, the higher Green Mountains of Vermont have only three zones: the deciduous and fir forests and the glacially-carved summit cliffs.

The boundary between adjacent zones is not a straight line. Each reaches into the region of the other as a result of microclimatic variation. Vegetation in the dark and damp of a deep ravine will be much different from that of a well-drained forest at the same altitude. *In order that the transitions remain clear, mountainside facilities*

should not be built at the edge of any climatic zone.

Although it is clear that throughout the world natural conditions tend to persist long after the constructions of men have crumbled, over the short term men have been able to build over and grey out such distinctions and thereby, at least temporarily, to destroy the association among parts of the landscape that provide its character. No matter how carefully it is planned, development will obviously change the landscape, but it need not destroy the basic physical structure. Parts can be modified but the distinctions among those parts can be preserved.

Because the summit itself defines

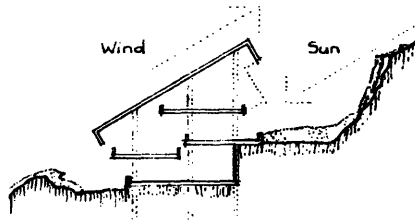

ski trails

Protection

the boundary between the mountain and the sky, it is not an acceptable building site. The band of exposed bedrock is too steep for skiing and will not hold snow, so the summit house should be located just short of the boundary between the evergreen forests and the rock band. Only ground pitched nearly parallel to the sun's rays will hold snow cover into the spring. The facility must be located on the north side of the summit, then, to support spring skiing. The space between the cliffs and the building will define the start of the ski trail system.

Unfortunately, most ski trails begin and end where terrain features begin and end. The congestion which occurs at the trailheads, as skiers try to decide which way to go next, makes it nearly impossible to experience the continuity of the mountain landscape. *Skiers of all levels should have the opportunity*

to experience a wide variety of slope angles, trail widths, snow textures, and degrees of natural enclosure on every run they take. The instability of mountain weather, however, requires that natural or built shelter always be near at hand.

Even on days which seem ideal in the valley, the weather can be quite unpleasant at the summit. With a drop of as much as 4°F per thousand vertical feet, and with increased wind velocities, winter lift-riders will often need substantial protection upon arrival. *The lack of natural tree cover at the alpine summit calls for a more protective artificial enclosure than would be required at lower altitudes.*

Experienced hikers realize the value of tree protection, especially after having descended from the alpine zone in bad weather conditions. This aspect of vegetative

cover is most important to the designer in the planning and location of campsites, where protection from the elements is a requisite of good site location.

The presence of more delicate ground cover calls for consolidation of hiking trails and the prohibition of camping in and near the alpine zone.

Small trees and shrubs at treeline grow in interdependent communities called krummholz. Removal of one tree in a patch of krummholz can jeopardize the other trees in the patch, which join roots and branches in protection against wind and cold.

The idea of spending the night very close to the summit, but with the option of being either partially or completely out of the weather, will undoubtedly draw large numbers of people to the summit house.

For the protection, then, of



Proudman, p. 29.

Proudman, p. 44.

both the natural environment and its human users, a building in the mountains should emphasize the differences between summer and winter access. The summer-time continuity of the hiking trail can be reinforced by carrying the series of switchbacks right through the building. The tops of dangerously steep and slippery cliffs can be reached by a bridge from an upper floor of the summit facility. After entering in

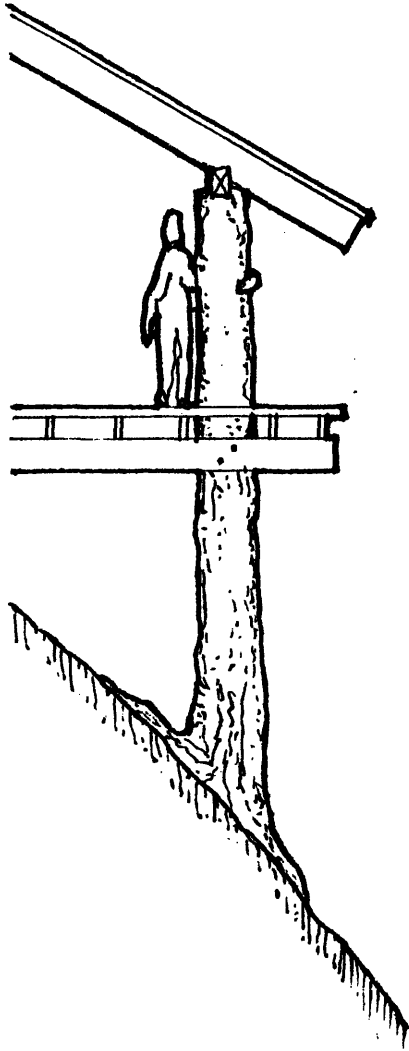

Cardwell, p. 84.

winter, skiers will spiral inward toward the warmest, most protected place in the building. Changes in temperature and in the degree of enclosure, however, must be gradual.

The base of a tree is a zone in which the earth of the forest floor gradually gives way to the natural column which projects from it. The roots reach down and out into the soil to anchor the tree in place. In the Grove Clubhouse, architect Bernard Maybeck preserved the solid anchorage that trees had established in the steep slope of the site. The beams for the building platform were bolted through the sides of the tree trunks. The trunks were sawn off at the eaves to provide platforms for the roof rafters. Maintenance of the natural corner between the floor and wall of the forest allowed straightforward construction on an otherwise unbuildable site. By letting the trees run the full height of the walls, the building became a

zone of transition between natural and built forms.

Similarly, a transition from outside to inside the building must have aspects of both environments. The greater the variety of architectural elements available, the more gradual can be the transition. If complete protection in a three-sided Adirondack shelter is achieved when one is nestled in a sleeping bag at its back wall, partial protection comes in at least three stages. It is possible to be under the roof and out of the wind, under the roof and out of the sun, or under the roof and out of both the sun and wind. Each degree of enclosure is useful in dealing with a different combination of temperature, windspeed, and precipitation.

The mud-room that is an integral part of every alpine home is simply the unheated space between the weatherskin and the insulation that was described earlier. It enjoys

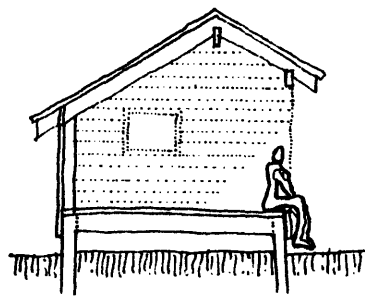

in the sun

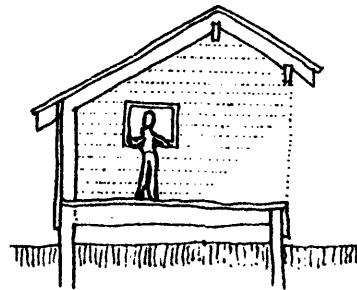

in the wind

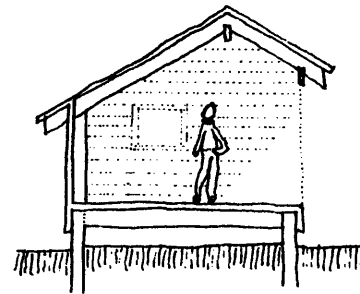

out of the paths of both

the sheltering qualities of the roof and is separated from both the inside and outside by doors. Heat loss is minimized if only one door is open at a time. Revolving doors would be even better there, because the angle between the leaves is smaller than the arc of the closure. The process of entering brings with it only a small volume of outside air, and no wind. Unfortunately, blowing snow would quickly jam it.

The tendency for cold air to settle is taken full advantage of in the Eskimo's igloo. To enter, one must descend first. Only after crawling through the curved entrance tunnel can one climb up into the

heated chambers. The plan of the entrance keeps out the wind. The section keeps in the heat. *Winter entry into the summit station will be modeled on that of the igloo, in plan and in section.*

Built Transitions

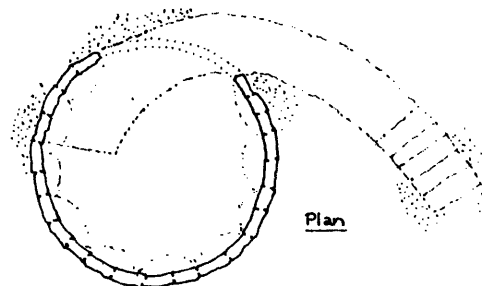

Plan

THE IGLOO

(adapted from Rapoport and Zrudlo)

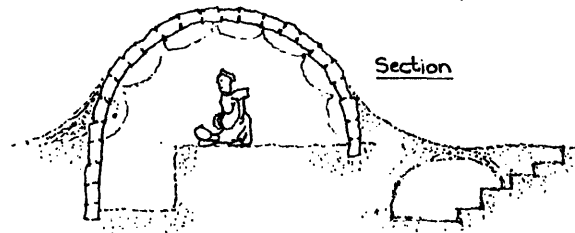

Section

COOPERATION

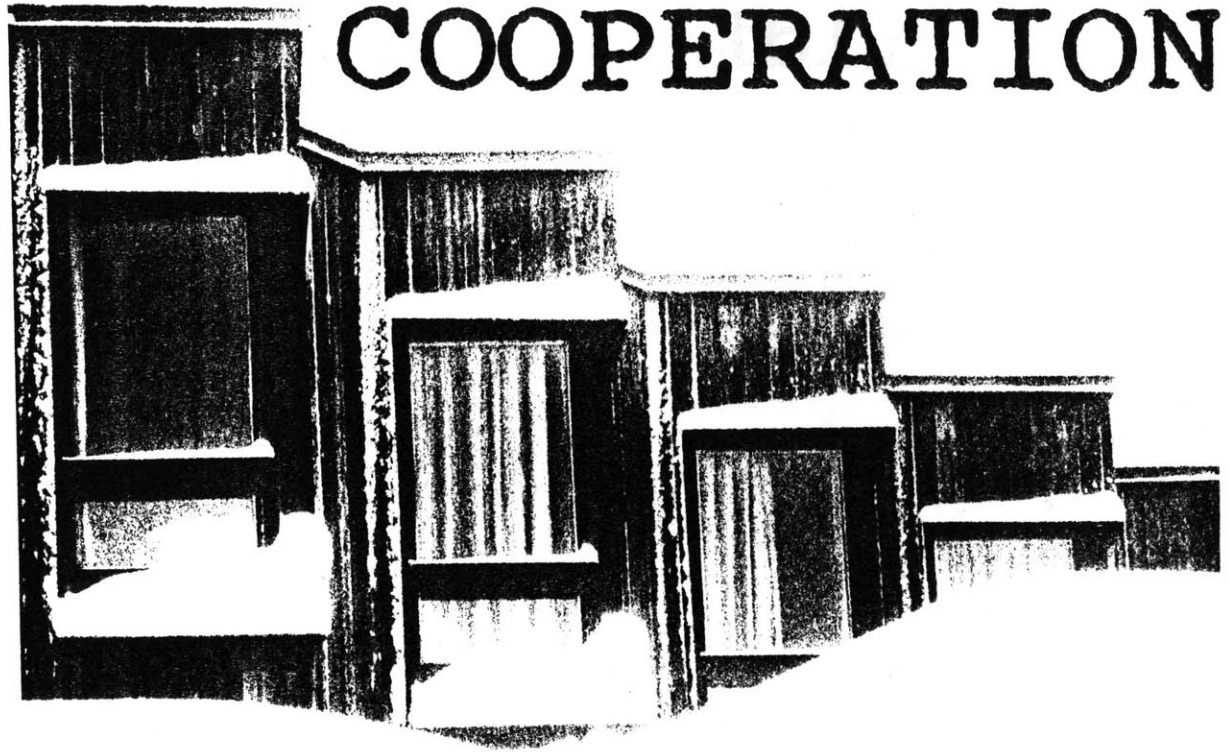

Building Process



"Never move more than one thing at a time!"

George Schaller in
The Snow Leopard

The extremely violent freeze-thaw cycles which characterize the alpine environment place great stress on building materials. In response, alpine builders over the centuries have developed and employed construction techniques which could tolerate the thermal and moisture-related movement of natural materials with high resistances to freeze-thaw damage. The dry-laid foundation walls were often left exposed. The interstices were large enough and sufficiently sloped to assure adequate drainage. Masonry walls built with mortar were protected with a continuous surface of stucco.

The wood superstructure projected

beyond the foundation wall to shield it from wind-driven rain, and to keep the perimeter of the house free from large accumulations of snow.

Tanne was the preferred species of wood. It was readily available in the Alps and naturally decay-resistant. The low temperatures of winter were resisted by solid 4"x6" wood sheathing boards stacked crib-like to enclose interior rooms.

Moss, used to fill the open joints between wall-boards, was compressed by the weight of heavy tiles or flat stones and snow on the roof.

Most of the housebuilding lumber was air-dried for a year or two before use. Although its moisture content dropped dramatically during that time, it continued to shrink for years after it was installed. Because the exterior walls were composed entirely of wood

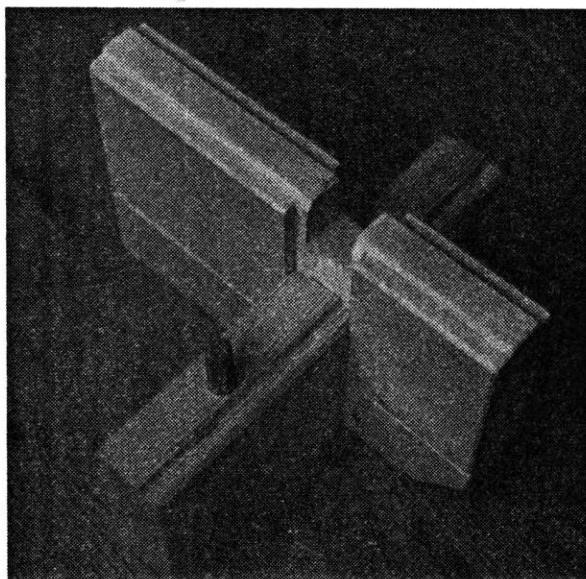
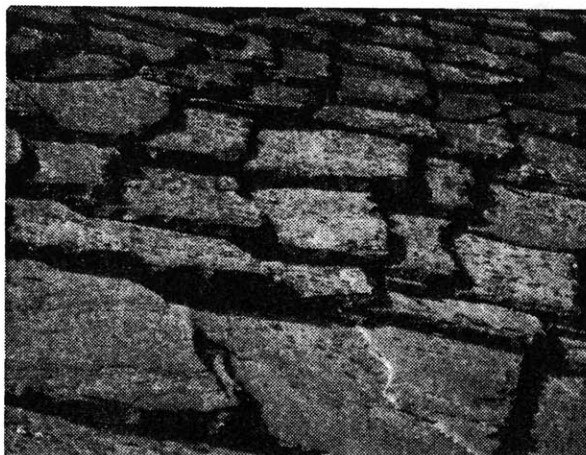



to penetrate the weatherskin of the building. The last tongue-and-groove floorplank was installed from outside the shell of the house, through a hole left in the sheathing. Its trailing end was slightly flared so that the weatherseal got tighter the further it was driven. The floor joints were much tighter, too, than would have otherwise been possible.

A different set of materials has required a different class of solutions. In his steel and concrete mid-rise housing in the arctic, architect Ralph Erskine has either hung balconies from cantilevered roof members or supported them on columns whose footings are independent of those of the heated building. *The objective in each case has been the elimination of thermal bridging and differential thermal movement arising from the passage of interior structure through the weatherskin into the*

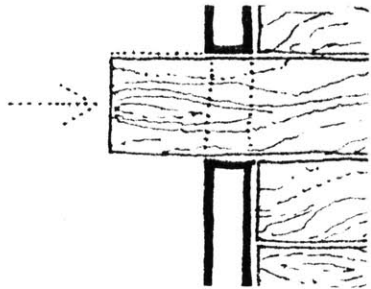

Goldstein, E.: "A Comparison....," p. 2.

oriented across the grain, they were subject to tremendous shrinkage over the lifetime of the house. The 'gwatt,' the joint at the corner, was designed to get tighter as the wall shrank.

Only materials of low thermal conductivity, like wood, were allowed

extremely cold outside air.

Composite construction of wood and stone was required in particularly cold areas, such as the Engadine Valley of Switzerland. The walls of the dwellings there may appear to be exclusively of stone, but are

likely to be of solid wood either stuccoed or covered with an actual outside wall of stone stuccoed. This double wall combines the wind shielding properties and strength of masonry with the insulation of wood.

The negative effects of the cold downslope winds from the north were minimized by orienting the roof ridge perpendicular to the contours. This gave the north wall less exposed surface than the south. The relationship between the dwelling and the hill became analogous to the relationship between a dormer and the roof from which it springs. *The*

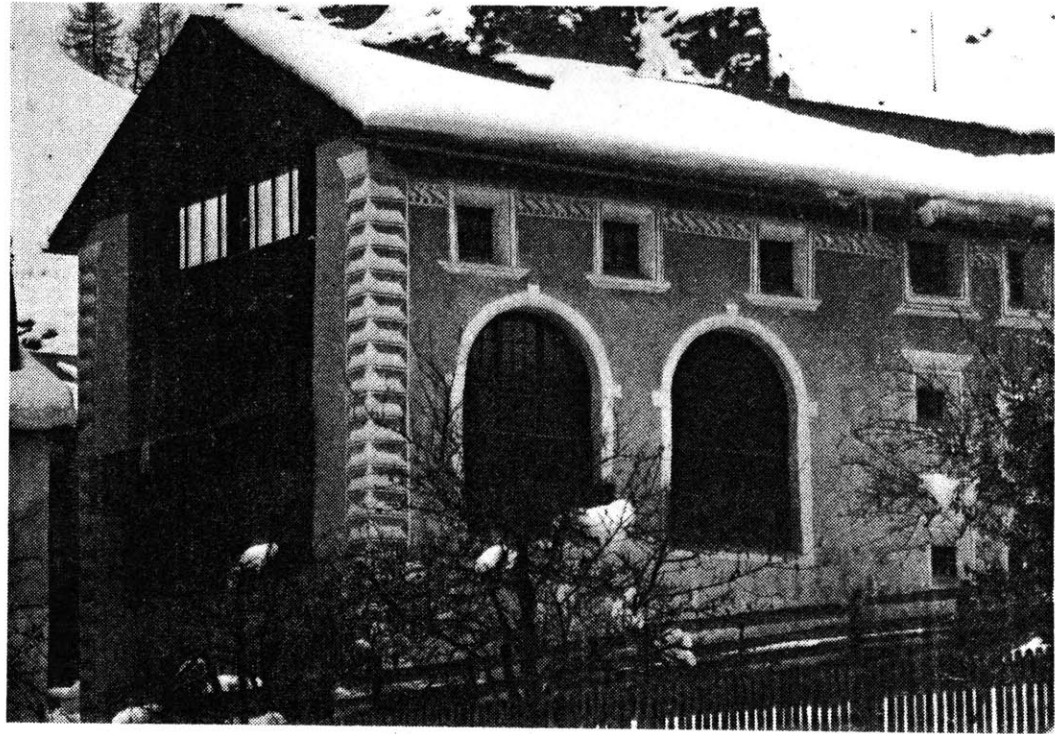

Smith, G. E. Kidder, p. 66.

dwelling became a dormer of the hill.

In the typical dwellings of the region near Saas-Fee, major differences in use are expressed with different materials. Minor differences are expressed with similar materials in different forms. In Graubunden, where wood and stone overlap within

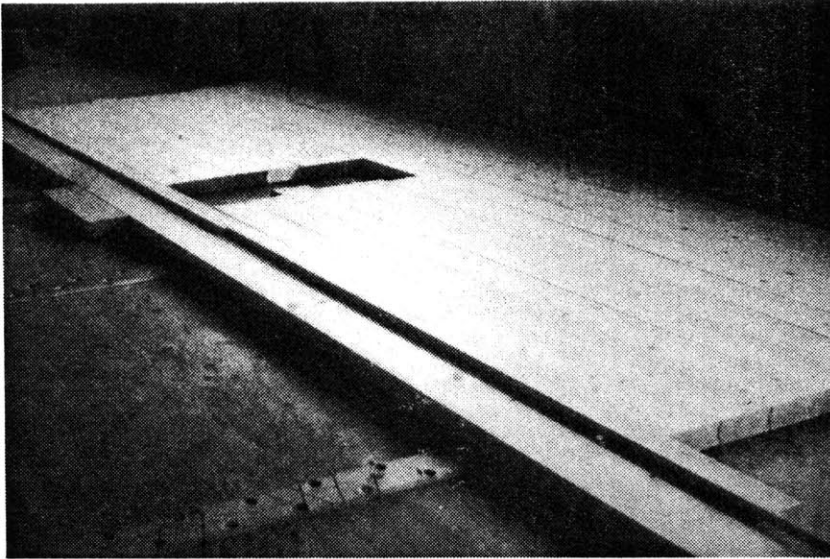

the thickness of the walls, a variety of material combinations appear which express and support more subtle differences in use. The exterior walls, though, are most commonly stone. In Himalayan wall construction, on the other hand, interior and exterior faces of outside walls are built of wood planks. Tensile members of wood connect them. The cavity is filled with stone rubble.

The simplicity and clarity of the building section, combined with the small number of variations on the basic house plan, made the wood superstructure of alpine houses a prime candidate for prefabrication. Working in his shop through the winter, the zimmermen (the revered house-framing carpenters) cut and fit the wall boards, assembled them on the floor, marked and sawed window and door openings, and notched the rafters to receive the thick roofing tiles. When all the components had been prepared, they were delivered to the site and assembled for the final time. After the roofing tiles were installed, the house was tight.

The problems of limited site access and a short construction season led to the adoption of building processes which minimized on-site construction time and maximized worker productivity during the long

winter. These same constraints have led to the development of a variety of other delivery and assembly techniques.

As recently as 1962, most of the materials for Appalachian Mountain Club cabins in the White Mountains were brought on foot.

A total of 39,950 pounds was moved up to the site, 7,000 pounds by airplane, 450 pounds by burros, and 32,500 pounds by backpacking. The donkeys tried a trip with roofing paper and had poor luck due to mud and poor trail conditions.

Buildings on Mt. Washington must withstand some of the highest wind velocities on earth. The frame of the old Observatory was composed of 9"x10" railroad timbers and was securely anchored to huge concrete footings cast in the gaps between the rocks at the summit. Structural calculations for the new summit



Sloat, p. 307.

house showed that uplift would be its most severe structural test. The speed with which steel could be erected convinced the architects that it was a more reasonable alternative than cast-in-place concrete, given the short construction season. The frame was encased in concrete after assembly to increase its mass and rigidity. The presence of the steel eased the forming of the concrete substantially.

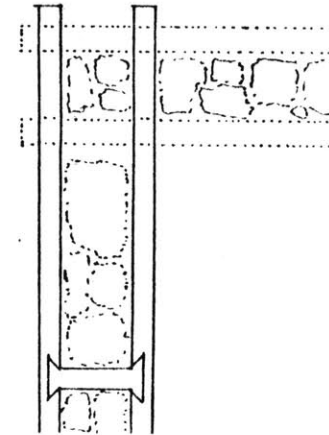



"Bridge-Like Structure....," p. 134.

Similarly, the use of prefabricated glue-laminated timber trusses at the Mid Gad Valley Restaurant at Snowbird drastically reduced erection time. The members were delivered to the site by helicopter in much less time than would have been required by any other technique.

In ski lift construction, heli-

copters substitute for the cranes which would be required otherwise, and take advantage of their much greater reach. Lift towers are customarily lowered onto and bolted into concrete piers which rest on and are anchored to bedrock. The concrete simply provides the level surface from which to build. *To take best advantage of a helicopter, therefore, the structural pieces for the summit house must be prefabricated, regardless of the specific materials of which they are composed, and like the lift towers, they must be erectable with a minimum of sitework.*

The high degree of prefabrication will expedite the outdoor work, as it did during the construction of the summit house at the Shilthorn, above Murren, Switzerland. It does not, however, address the problems of finishing the interior. Indoor work at the summit house in winter will be possible only if the shell

is weathertight. Because heavy construction equipment cannot be gotten to the site, materials for the interior must be small enough that they can be delivered by lift or snow vehicle. Early completion of the lift, therefore, must have high priority.

Although pier support for the lift can certainly be justified by the ease and speed with which it can be provided, pier support for the entire building cannot. The summit house must not ignore the ground.

Under each corner of the detached hay storage shelters near Zermatt is a large flat stone. Slender pillars about one meter in height support the stones. The separation from the ground and the circuitous profile of the supports is intended to keep rodents from getting to the hay. The dissociation from the ground is intentional.

It is more reasonable, on the other hand, to expect the structure

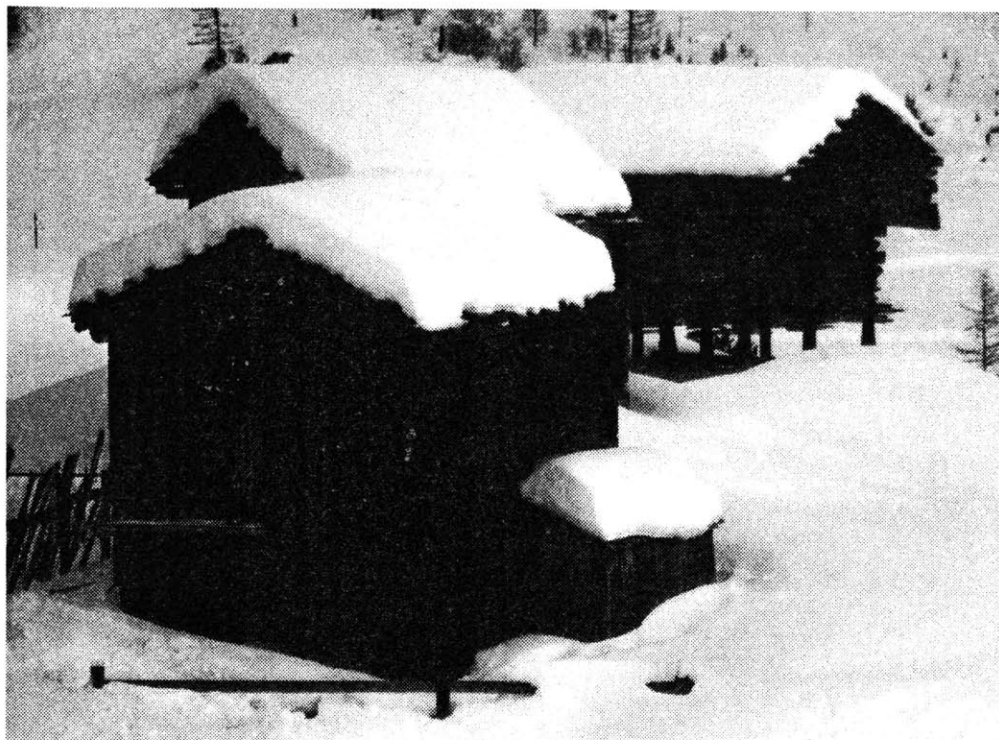

to get more massive as it approaches the ground. Mahone could be referring to any number of buildings by H.H. Richardson when he states:

This rough stone establishes a firm base that acts as the formal transition from the rocky ground to the superstructure. The base is

Mahone, p. 51.

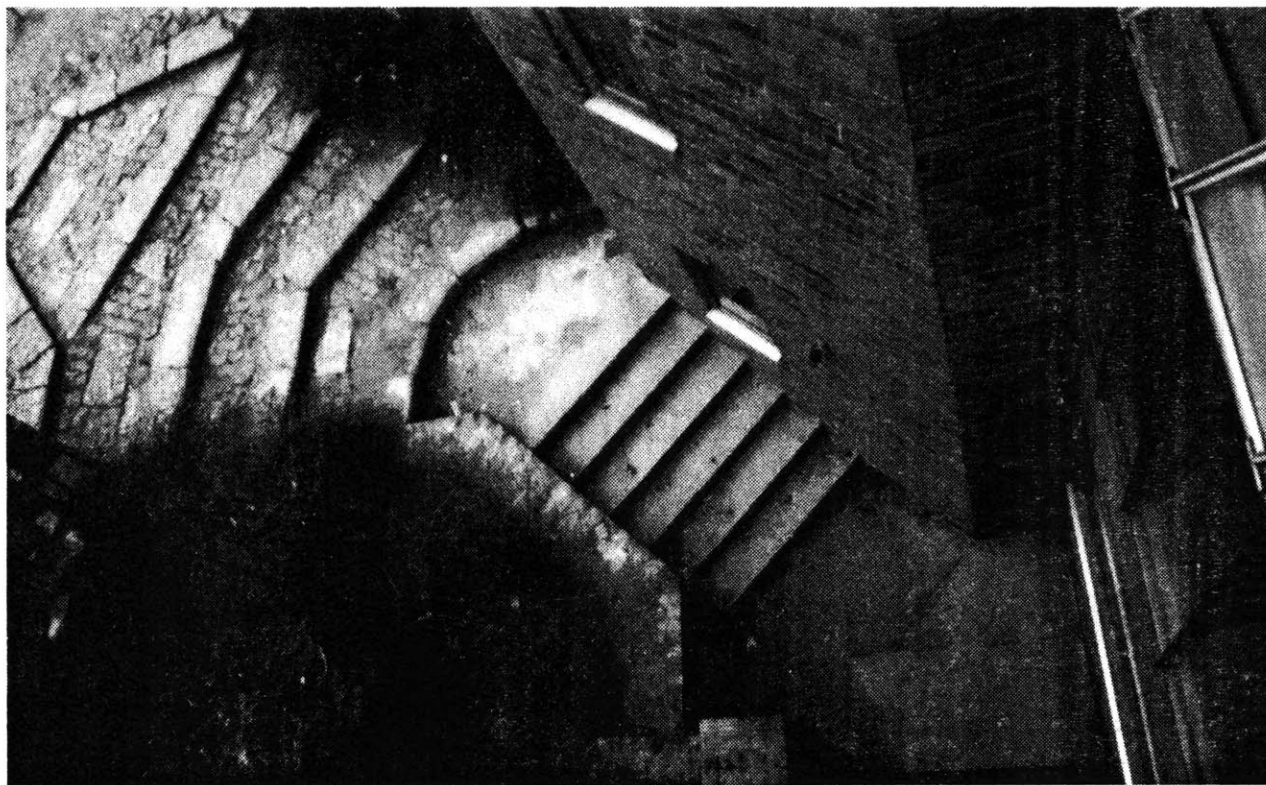

designed to enhance this transition... by the random coursing of the split-face stone... the battering of the wall recalls natural rock formations, and the structural imperative of widening the base to spread its accumulated

loads...reduce to only one space onto a larger area of ground.

At the dormitories of the Catholic University of Louvain Medical School, Lucien Kroll has gone one step further. The closer one gets to the level of the original ground,

the more ground-like are both the walls and the floors.

At the summit station, continuity with the ground will be provided by cast-in-place concrete exterior walls, and brick and block interior walls. The use of high-early-strength concrete should enable the foundation walls to carry gravity loads soon after pouring.

But forces from at least two independent directions act on building frames. Only gravity acts vertically. Wind and earthquake loadings are primarily horizontal. Structural functions are often consolidated in the hope that materials can be saved or that labor can be reduced. Separation of functions is thought to lead to redundancy.

Many societies have had to deal with the natural forces of the ocean. The durability of their boats often resulted from the separation of structural functions. De-

scribing the Indians of British Columbia, George Dyson states:

...I studied their adaptable and efficient pattern of construction involving a light flexible frame covered with a tough waterproof skin. It was this combination of independently flexible frame and skin which enabled this otherwise light and frail craft to withstand the stresses of the stormy, shallow, and ice-filled northern seas.

Until the early twentieth century, medium-span arch bridges were built of materials strong in compression only. The dynamic loads generated by vehicles passing over them induced tensile stresses in the arch which were resisted only by the weight of its materials. Robert Maillart, a Swiss engineer and a pioneer in the use of reinforced concrete, concluded that separation

Brower, K., p. 75.



Billington, p. 92.



of the form subject to dynamic loading from the form best able to carry static loading would result in a lighter structure. The deck was made stiff enough that the concentrated loads it received could be transmitted as distributed loads to the arch, through vertical struts in compression. The slender arch he specified weighed much less than the massive ones previously required.

As long as construction loads were distributed uniformly along the arch, it was possible to build it with very light scaffolding.

The behavior of the bridge followed directly from the underlying conceptual structure of its design: independently defined functions.

To the mathematical logician structure is a formal system of relations of certain logical types, and the emphasis in all usages is on the relations

rather than on the terms or entities which they relate.

Once the spanning action was defined with distinct forms, Maillart could have built each with different materials. Since the arch no longer had to resist great tensile stresses, it could have been built of unit masonry, a material very strong in compression. It could have been nearly as slender as the reinforced arch actually built. Further material efficiencies could have been achieved if the arch had been placed above the deck, and tensile ties had connected them. If the forms were to overlap in elevation, a greater variety of spatial conditions would have emerged.

Similarly, the summit house must respond separately to each of the natural forces acting on it. Forms which relate to each direction in the same manner would only be appropriate if forces acted on every

part of the building in the same way. As has been shown, this is not the case.

The desire to maximize passive solar gain requires that a substantial piece of the building run along a primary east-west axis. The establishment of northeast as the best orientation for ski trails, with adequate sunshine and wind protection, requires that the direction of contours defining a northeasterly slope be considered a second primary direction. Even though the wind will be somewhat useful in clearing outdoor surfaces, the width of the building facing the wind will be minimized and its direction will be considered secondary to that of the contours.



Kepes, p. 21.

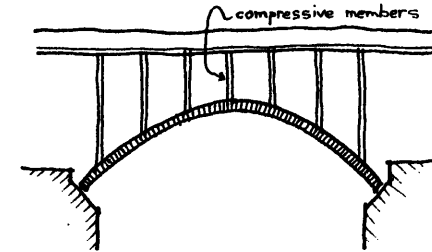

DECK OVER ARCH

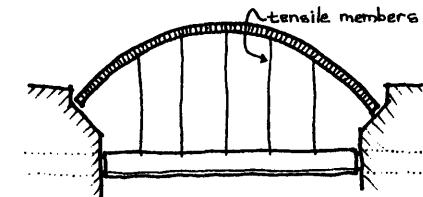

ARCH OVER DECK

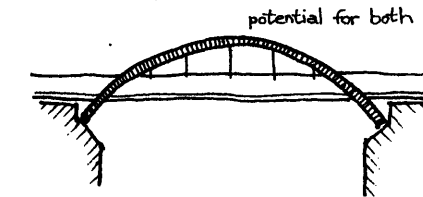

OVERLAPPING FORMS

Directions

The building must take a form which is streamlined with respect to the wind, but which is heavily exposed with respect to the sun.

Providing a directional continuity with the contours on the northside will maximize scouring of the roofs by, and minimize surface area

Martinelli, p. 1.

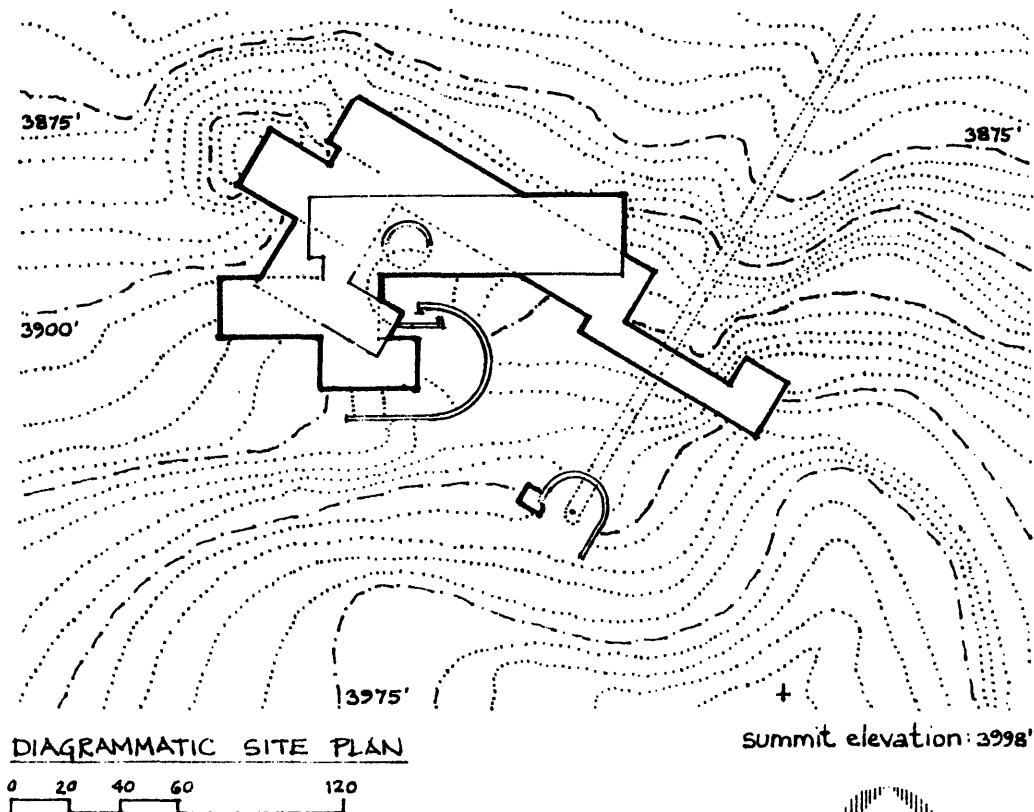

exposed to, the wind. The north-facing roofs, therefore, should be parallel to the 25-30° mountain slopes below them. To assure that snow deposited on south-facing roofs does not accumulate sufficiently to endanger people below, they must be pitched enough to shed snow spontaneously. "A simple, clean, steep, slick roof is certainly strongly recommended in areas of heavy snowfall or severe wind deposition." When the roofs are glazed, the 60° angle required for shedding will maximize direct solar gain in winter.

The combination of a north-facing roof conforming to the contours and a south-facing roof faceted to intercept or shade itself from the sun makes reference to the mountain forms which were carved by the advancing glacial ice sheets.

One...facet of the plucking process may simply be the drag force exerted by the ice

passing over a cliffed face and thus causing semi-loosened rock to move downstream. If one looks in the direction in which the ice travelled, the smoothed abraded stoss slopes are visible; if one looks in the direction from which the ice came, the rough plucked lee slopes are visible.

In vernacular alpine architecture, sectional continuity is provided in three locations: where the building meets the ground, where the wood superstructure meets the foundation, and where the roof meets the walls.

Where the building meets the ground, continuity is provided by

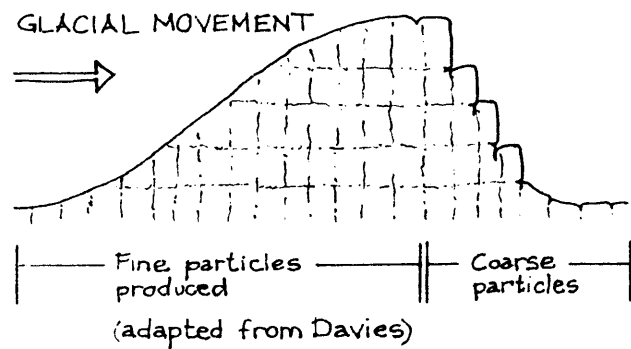

EXPOSURE OF HEATED BUILDING

Davies, p. 105.

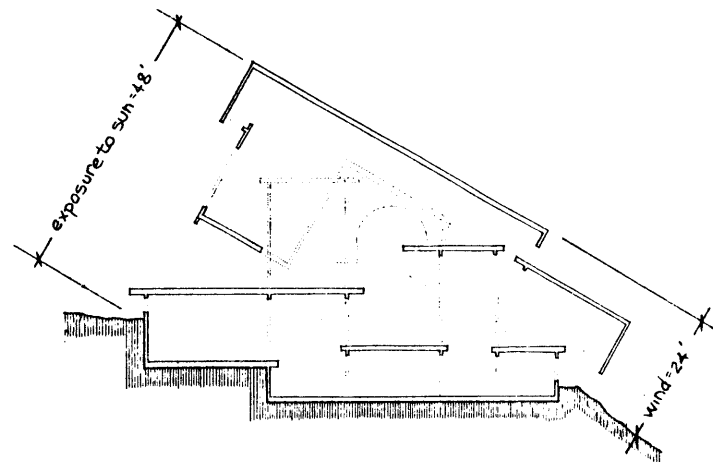
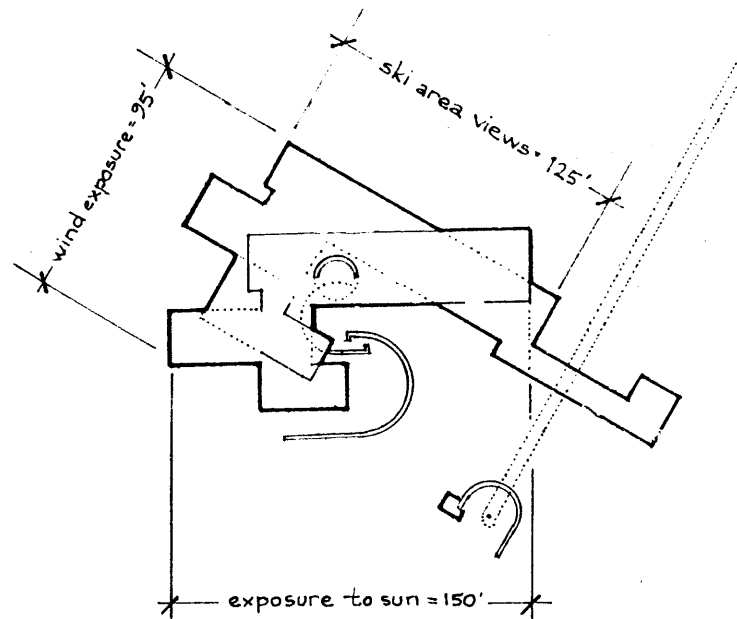

BUILDING SECTION

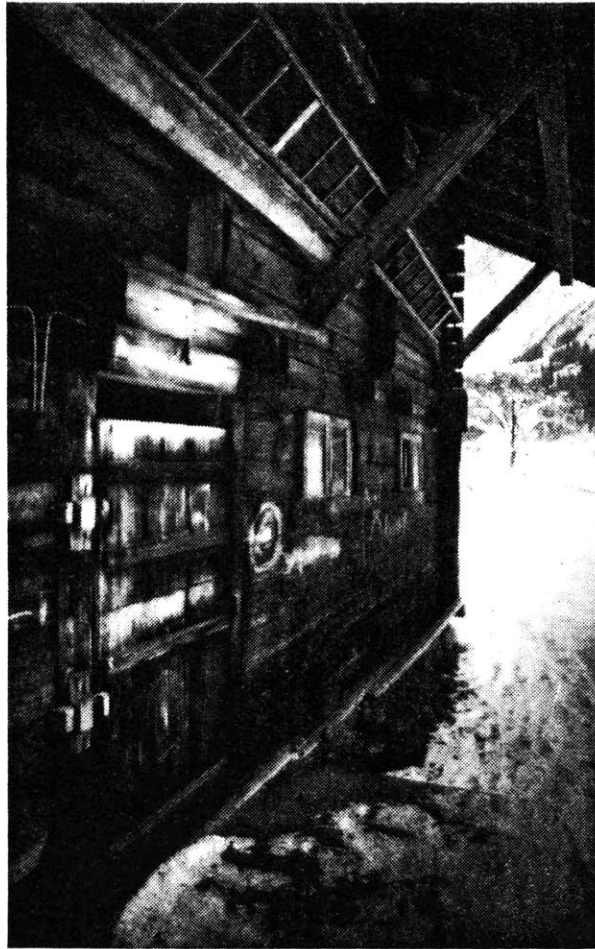

the materials. Stones found on the site are assembled on top of the bedrock of which they were once a part. The differences between the natural and built stone forms result

from the differences between the processes by which they were created. Erosion is primarily a subtractive process, while stone construction is an additive one.

From the foundation to the superstructure, the direction of growth remains the same (upward), but the materials change. The wood weatherskin is usually projected beyond the stone walls. An aggregation of the relatively small pieces which compose the foundation walls begins to establish a continuous surface, particularly if covered with stucco. The wood framing and sheathing boards are lineal members. Their structural capabilities include cantilevering and tensioning, actions the stone cannot perform.

Continuity of material characterizes the shift from the orthogonal walls of occupied floors to the symmetrically sloped planes of the roof. The areas under the eaves are further defined by diagonal braces

which are sometimes partially enclosed. Storage of tools, ladders and lumber often occurs in this space.

Alpine house plans, on the other hand, manifest only the direction of the contours and in only a passive way. Precedents for multi-directional plans must be found elsewhere.

The plan of the Basic Sciences Library at the University of Iowa was generated from two grids shifted 45° from one another. Architect Walter Netsch chose to slope the roofs of one grid, but to keep flat those of the other. The roofs are glazed when they cover the overlap of the two grids. All columns are round. Beams from every direction frame into them in precisely the same way. Unfortunately, this blurs the building's directional differences.

Richard Tremaglio's Arena House plan is composed of two axes shifted

45° from one another. Although almost all framing members run in the same direction, the partial enclosures, both inside and outside the house, relate to a larger organizational scheme in which both directions play major roles. What results is

an efficient center, allowing two regions - the family-kitchen and living-dining - to interlock. Instead of the center being taken up with movement, it became an overlap of the two regions.

In any building in which at least two structural systems with different directions are employed, there must be spaces which are partially defined by each. Just as such spaces will have aspects of the generating directions, they should share some aspects of each of the adjacent uses. In the summit house, the indoor space partially defined by the dominant directions is the

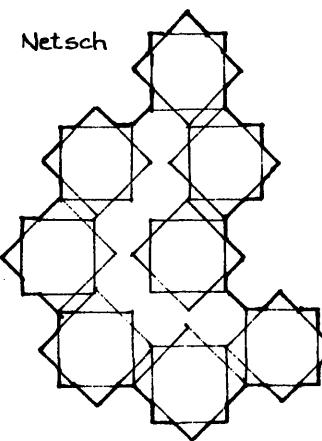

"The Arena Residence...", p. 126.

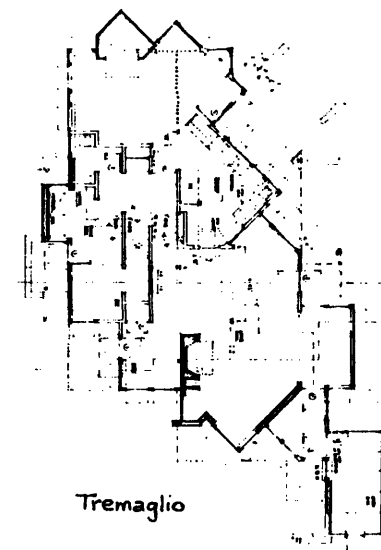

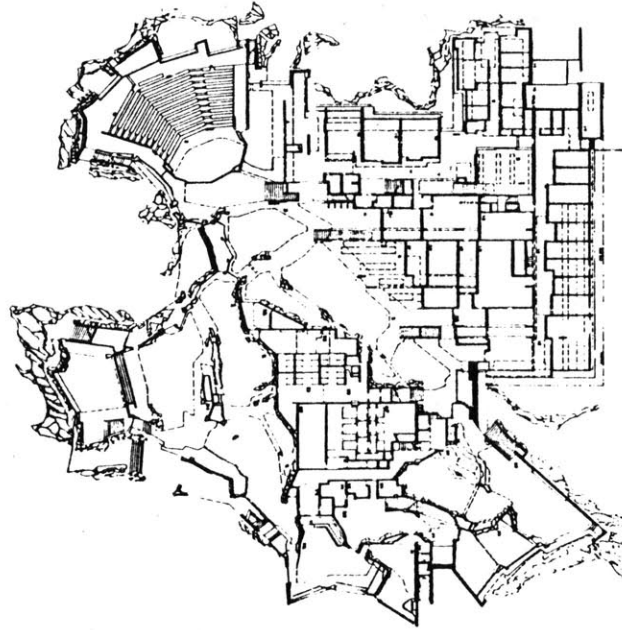

major gathering place. It is further reinforced by an enclosing cylindrical form which acts as the 'hinge' for the directional shift. The arch in the elevation of the post-tensioned concrete bents acts as the hinge for the two geometries of the section.

Two buildings in Otaniemi, Finland utilize major gathering spaces as hinges. The sides of the form containing the lecture rooms in Aalto's Technical Institute establish the two directions of growth for the building. One edge of the auditorium in Pietila's student center is built on the rougher quality of the bedrock outside its walls. The hinge allows qualitative as well as directional changes.

Qualitative changes occur in time as well as in space. Growth is as essential in built as in natural environments. Growth in nature always manifests the interactions between biological processes and

physical constraints.

The little round gourd grows naturally, by its symmetrical forces of expansive growth, into a big, round, or somewhat oval pumpkin or melon. But the Moorish husbandman ties a rag round its middle, and the same forces of growth, unaltered save for the presence of this trammel, now expand the globular structure into two superposed and connected globes.

Growth of total form can result from the addition of identical components, from changes in the dimensions of existing components, or from the substitution or addition of new and different components.

In the early colleges by deCarlo at Urbino, a slightly trapezoidal living unit is identified and distributed in rows along the contours. Slack is provided between clusters of about a dozen units so that irre-



Thompson, p. 67.

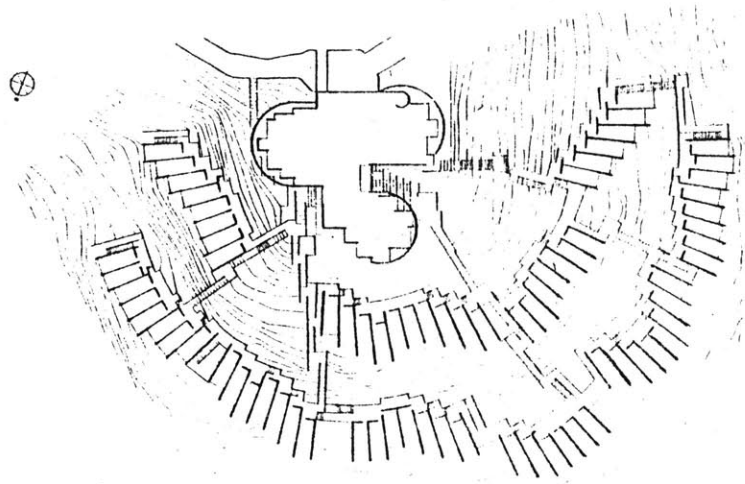

Growth



Goldstein, E.: Usonia, p. 8.

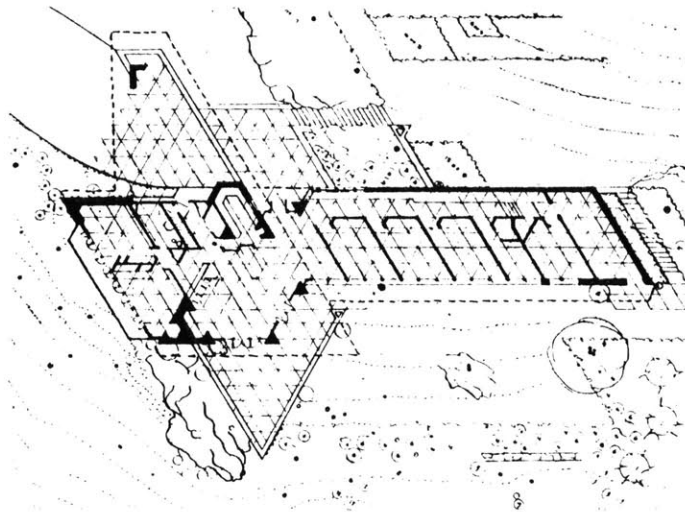

gularities in the terrain can be accommodated. Access perpendicular to the contours occurs between clusters. The total form is predictable from the pieces which compose it.

Frank Lloyd Wright's Reisley House, near Armonk, New York, was generated from a triangular module. Two of the directions can be observed in the site contours. The third seems to have been assumed. Like many of Wright's other Usonian projects, this house was built in stages. Initially, the house contained dining and living spaces sized to serve the planned family. It had only one bedroom, though, because the husband and wife were the only occupants at first. The master bedroom was oriented to suggest the direction of future bedroom additions. The form of the completed house resulted partially from the addition of identical planning modules and partially from

a change in the length and character of the bedroom wing. The total form was only partially predictable from the initial form.

In built form as in everyday life, symmetrical decisions, those involving choice between seemingly equivalent alternatives, are the most difficult to make. Because Wright's planning module was equilateral, it blurred the differences between its directions. When Netsch employs two grids of square rotated symmetrically with respect to one another, no growth clues are provided. When common gable dormers are built at right angles to the main roofs from which they project, no growth clues are provided. The deployment of Tremaglio's geometries, on the other hand, is sufficiently directional that the total form provides the inhabitants with suggestions for future growth.

In order for two zones of use to be involved spatially with one

Parallel Geometries:

Shared Space

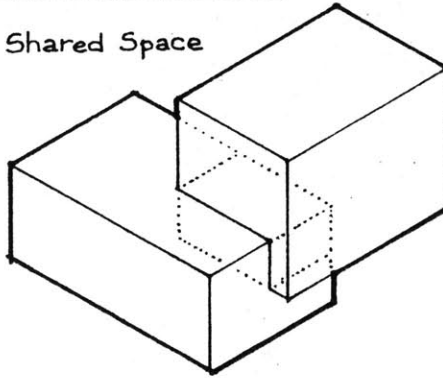

Skewed Geometries

Shared Space

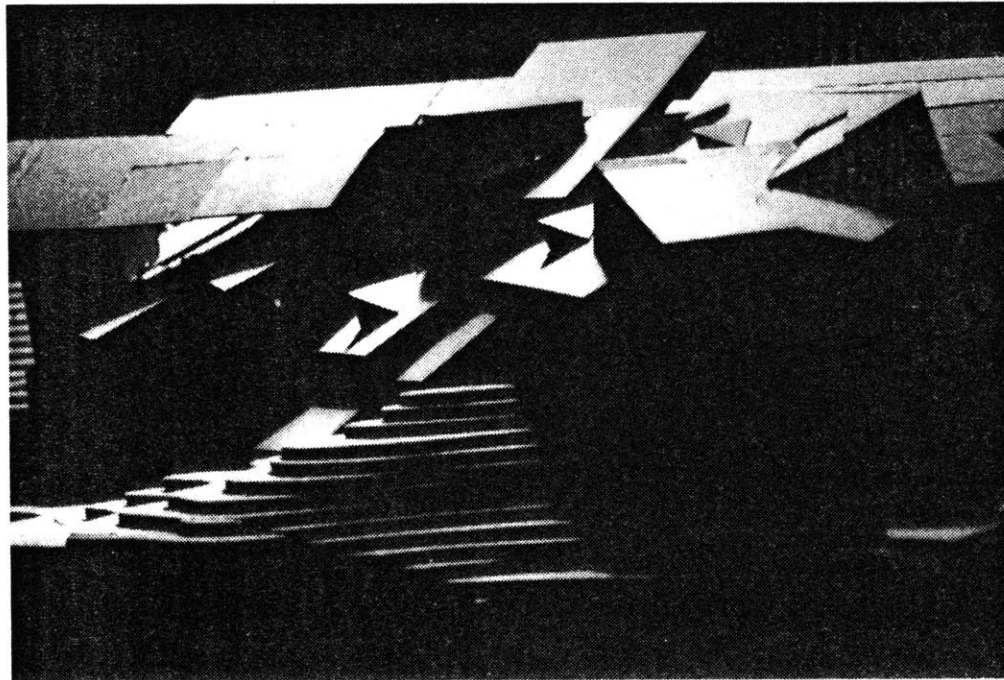
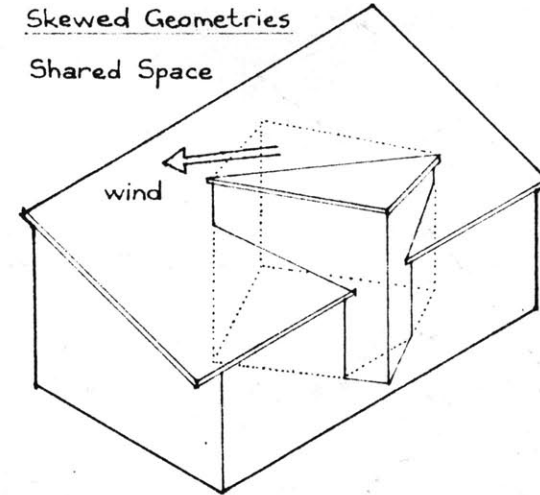

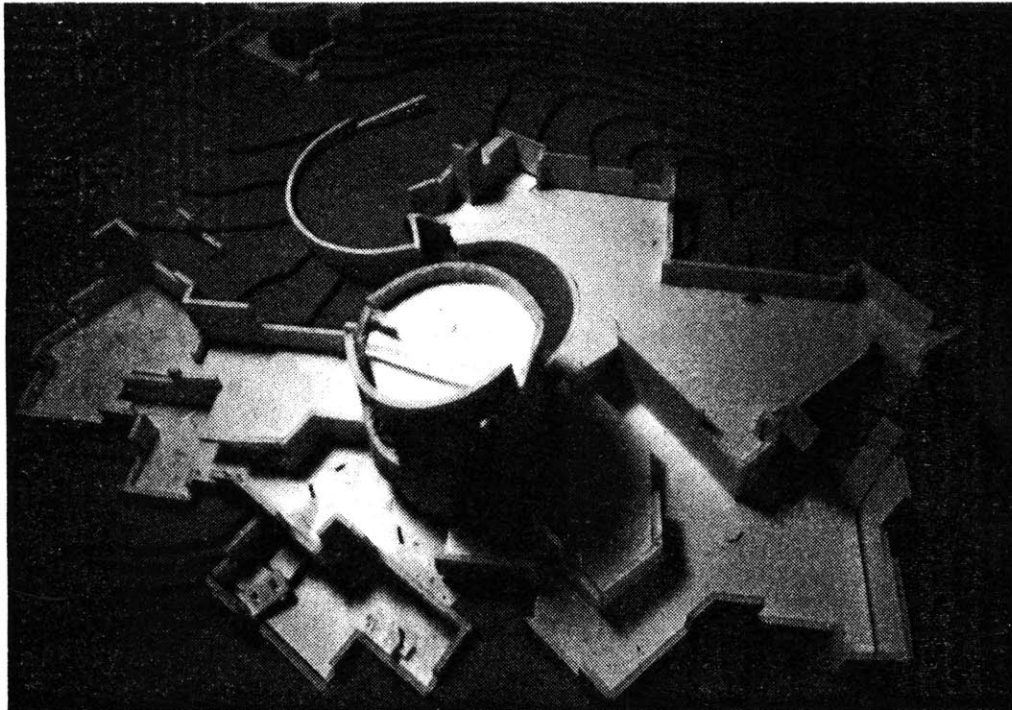
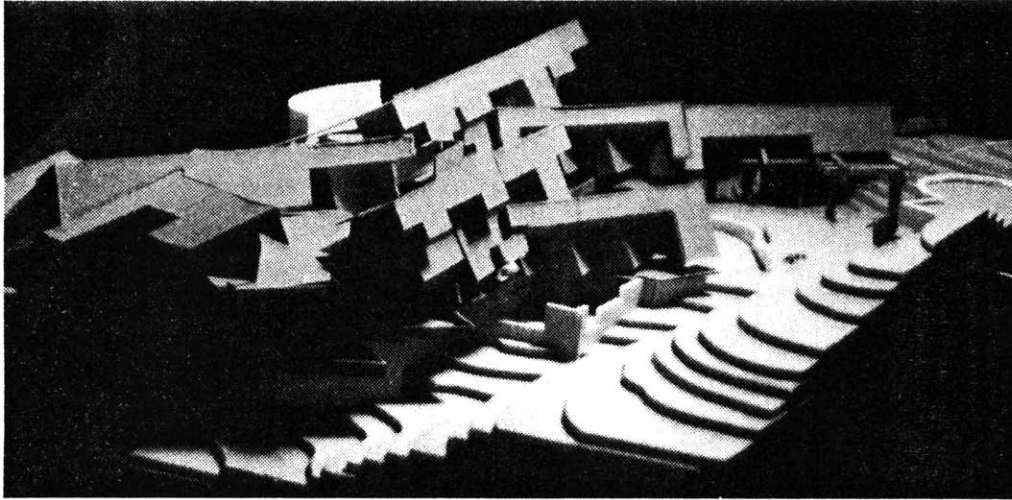

another, each must share part of its length, its width, and its height with the other. Similarly, in order for directions of movement to be exchangeable with one another, each must project some dimension onto the other. In general, since the uses enclosed by dormers are related to the uses enclosed by the roofs from which they project, the directions of the dormers should contain part of the primary roof direction, or should be part of a larger form.

The summit station will embody these principles in its response to wind. Those parts of the building which cannot take advantage of the wind will turn their backs to it. The dormers will open away from the wind and will share some of their direction with that of the main roof. During the few hot summer days, the suction created thereby can be used to ventilate the spaces under the roof.

The north-facing structural ele-

ments are exposed to the greatest wind pressures. Post-tensioned concrete bents composed of three pre-cast pieces will resist some of these forces. Masonry shear walls will resist the rest. The bents form a series of virtual arches through which the majority of the public path travels. *The pre-cast columns support the systems of enclosure for both the walls and the roof. This provides a continuity of material similar to that found in the same location in traditional alpine dwellings.*

To maximize the depth to which daylight penetrates in the interior, lightweight three-dimensional trusses will support the glazed south-facing roofs. They will be made of wood to reduce the problems of thermal movement on the side of the building subject to the largest daily temperature swings. They rest on cantilevered girders analogously to the way in which wood rafters get

direct bearing on beams. The bird's mouth cut in a rafter results from a subtractive process. The haunch of this truss has the form of a bird's mouth, but results from the addition of triangular modules to what would otherwise be an ordinary open-web joist.

The gable roof is supported by fire-treated plywood box beams. Their depth must reach eight feet to carry roof loads over such long spans. Their sloping south ends support windows oriented toward the highly reflective snow surface. *The sleeping rooms which occupy the upper levels of the building have lofts whose widths are defined by the spacing of the box beams.*

The characteristics of roofs exemplify the essence of shelter. The most primitive buildings were essentially all roof; this 'essence of shelter' is a protection and containment, and even if we

Freeman, p. 33.

watch a building from outside,
we expect a roof that encloses
space to be habitable, and
interpret it by imaginatively
placing ourselves within it.

Two floor systems are used. On the
south, floors are framed with heavy
timbers and planks. On the north,
the post-tensioned bents support
concrete plank floors and roofs.

The wood floor system can also be
supported on brackets attached below
the arches in the concrete bents.

Intermediate levels are framed this
way. *All members penetrating the
weatherskin are wood.*

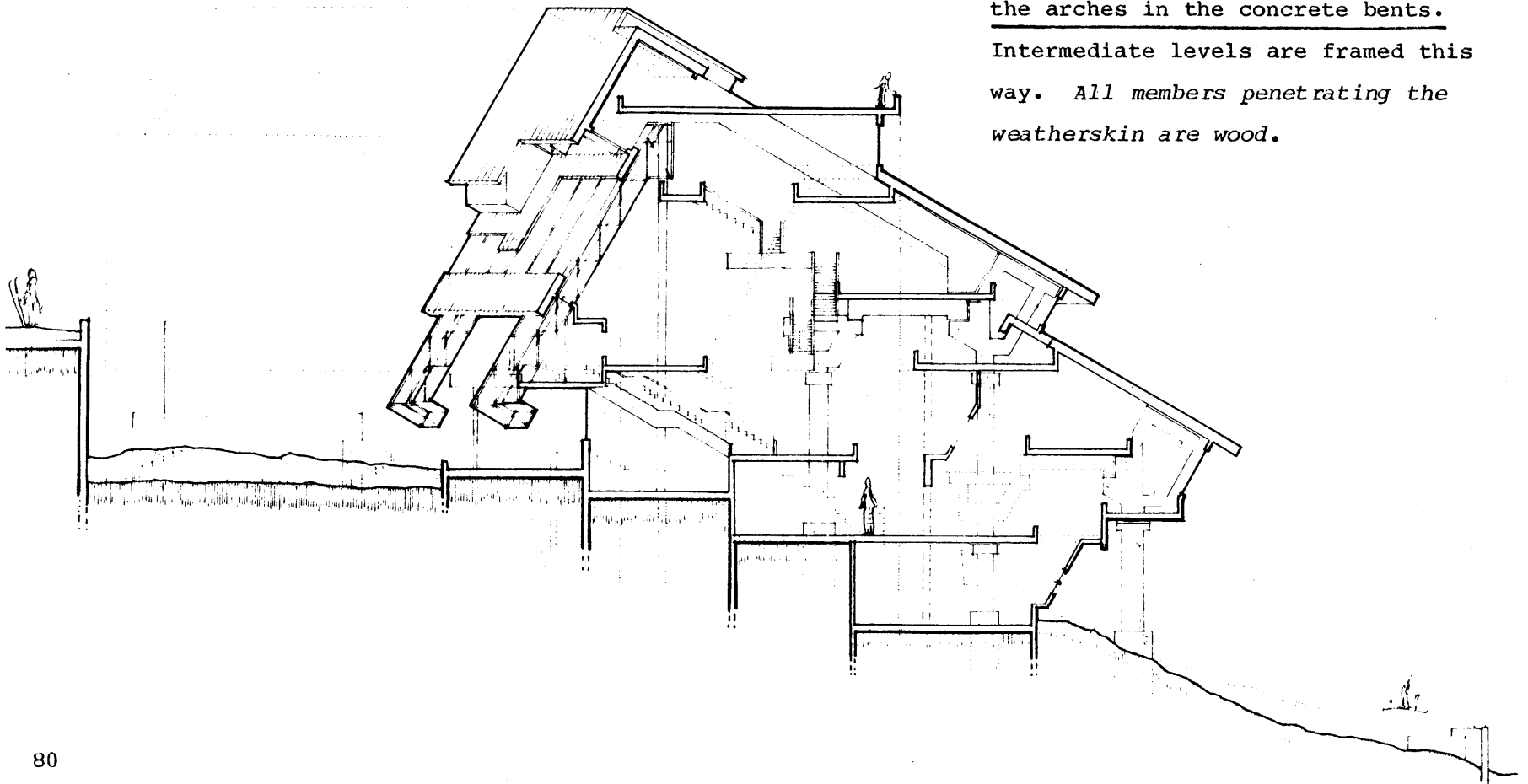

A minimum of differentiation of form in relation to force action produces a maximum variation in the force effect; a maximum differentiation of form in relation to force action produces a minimum of variation in the effect of that force. This generalization holds for phenomena in time as well as in space.

Knowles, p. 57.

Total Form

Differentiation

...material objects are not distinct entities, but are inseparably linked to their environment; ...their properties can only be understood in terms of their interaction with the rest of the world.

Fritjof Capra
The Tao of Physics

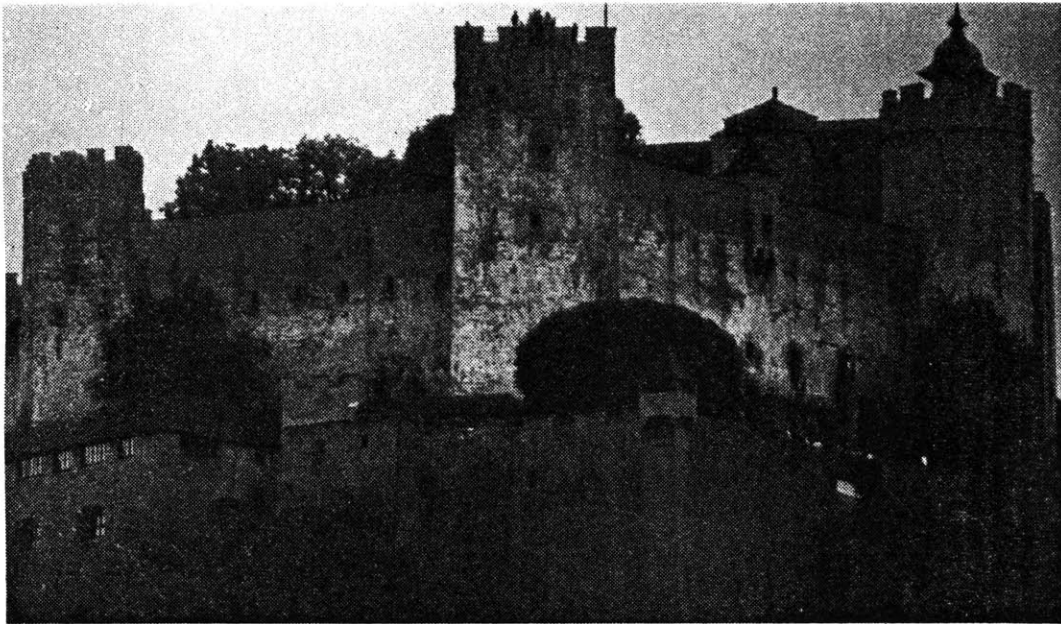

The forces of hostility and violence have caused many societies to build huge defense fortifications in the mountains. While being above one's enemies is certainly a military advantage, much of the defensibility of such fortresses resulted from the ways in which they reached into the landscape.

The ancient city of Toledo, Spain is situated on a hill bordered on three sides by the River Tagus. During Roman times, the river was used for commercial shipping. Movement along it was for peaceful purposes. Enemies tried to attack from across it. From the standpoint of commerce, the river was a boulevard. From the standpoint of defense, the river was a moat.

Similarly, turrets generally project from the walls of castles. Although this increases the attack-

able length of the wall, it enables the defenders to surround and bombard those people foolish enough to attempt scaling it. If the enemy was likely to gain control of the turret, the defenders could remove the floor between it and the wall. The new occupants of the turret would then be as exposed as their wall-climbing compatriots. *In each case, the extension of the built into the natural environment has increased the level of protection.*

Continuity with the landscape, on the other hand, can be achieved by making reference to its natural forms with built forms appropriate to the materials of which they are composed.

The castle of the Hofburgs sits on a dramatic hill overlooking the city of Salzburg, Austria. It is huge, and leaves little of the ori-

ginal summit intact. But because the profile of the fortress is a built approximation of the much smoother form of the hill on which it is constructed, it does not overpower the landscape.

The Gornergrat Hotel above Zermatt has a program similar to that of the proposed summit house. It overlooks a spectacular group of glaciers and deep valleys. In its massing, the stone building recalls

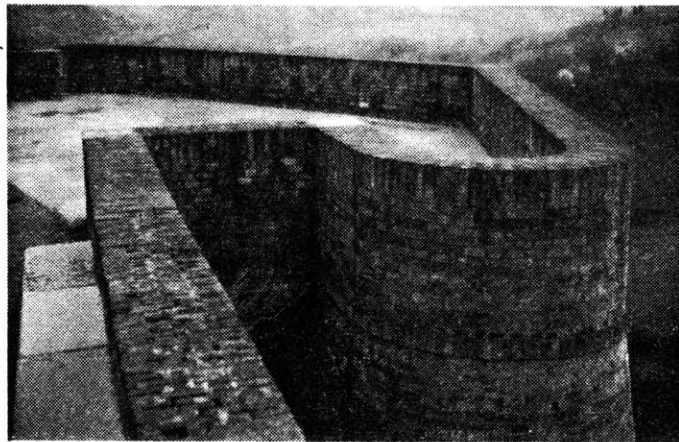
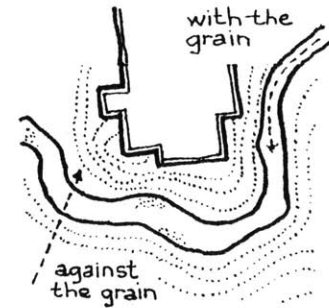

Continuity

a typical turreted fragment of the Salzburg Castle. Because it makes no reference to its surroundings, however, it appears to be a tiny object floating in a vast snowfield.

At Avoriaz, reference is made in several ways to the surrounding landscape. The largest buildings are nearly the size of the huge outcrops which occupy the adjacent hillsides. Their roofs are continuous planes which follow the slopes of the nearby cliff tops. The facades of the apartments are much more finely detailed than the roofs, and refer to additional aspects of the

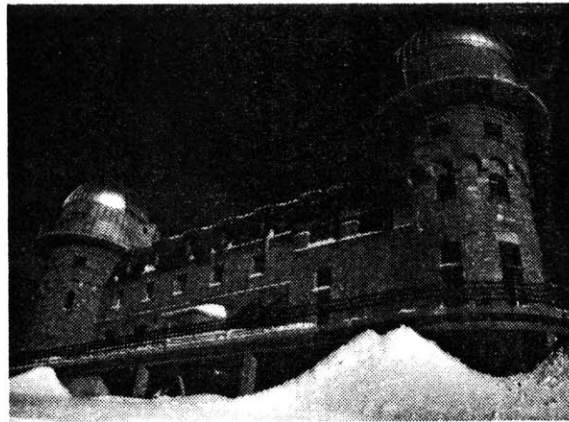

rock. When balconies occur in several adjacent units, they echo the stratifications in the cliffs. After a winter storm, this similarity is particularly noticeable. The white of the snow contrasts sharply with the darkness of both the balcony railings and the shadows above the rock shelves on which it collects.

Upon closer examination, however, these buildings lose their human scale. Although low in comparison to their lengths, they still reach heights of ten storeys. Because the upper-floor apartments are identical to those nearer the ground, one wonders how the architects determined when to stop stacking them. The facades never add up to anything greater than simply a collection of identical units. The roofs never appear at a small enough scale to relate to the different spaces they cover. The roofs appear to have been dropped into place.

Townsites are not usually chosen, as such. *Communities tend to develop where the combination of environmental forces seems to be comfortable or advantageous.*

Alpine villages were often built near valley floors. Although cool air settled at night, the air was usually warmer during the day there than further up the mountain slopes. The forests provided protection from the wind. Except for the fertile pastures near the summits, the valley offered the most gently-sloping building sites. The situation further to the south, however, was very different.

Italy's mountainous terrain provided... elevated sites, ideal for defense against marauding armies and protection from the malarial mosquitoes... the use of hill-sides, though it meant long steep climbs twice a day to the fields, preserved the

limited agricultural land of the valley floors.

Carver, p. 31.

Whereas alpine villages are composed of a number of detached dwellings, Italian hilltowns are continuous built landscapes. The most public spaces in the Alps occur where the density is quite low. The natural landscape predominates in the alpine setting. The sheltered and par-



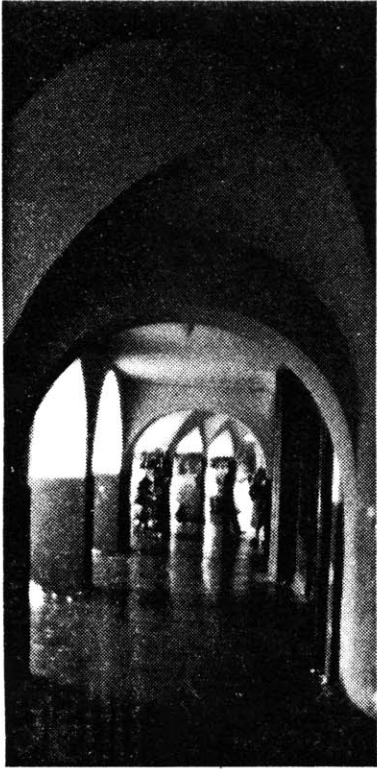

Public Form

tially enclosed spaces in the hilltown account for a much greater amount of the built environment than the open space.

The climatic differences between snowy mountains and Mediterranean hills generate many of the formal differences already identified. A comfortable building for a hot, humid climate exposes its inhabitants to breezes, but keeps them out of the direct sun. *In an alpine setting, the goal must be exposure to the direct sun, out of the path of breezes.*

The larger forms generated by the clustering of alpine dwellings occur between, rather than being composed of, the units themselves.

The uses of the outdoor space vary with the distances between units. Occasionally, the dimension will get so small that the overhanging roofs of private dwellings will overlap, and thereby protect the public path from rain and snow. Alpine dwell-

ings are objects in a snow-field. The squares and courtyards of the hilltown are objects in a built field. The figure in one setting is the ground in the other.

The architectural devices so attractive in Mediterranean towns are not applicable in snowy regions. The outdoor places where people normally gather are unusable after a snowstorm, even on sunny days. Neither sitting nor standing is possible in the courtyards because they are full of snow that has either fallen directly or that has been thrown into them as the public walks were shoveled. *The shopping arcades are clear of snow, but the deep shadows which keep them cool in summer make them uncomfortably cold in winter.*

On the coldest days in the Alps, people must keep moving in order to keep from freezing. A deep and continuous blanket of snow is, therefore, the most valuable asset in the

alpine landscape because it supports the kinds of outdoor activities which keep their participants warm. Cross-country skiers and snowshoers, for example, burn up tremendous amounts of energy primarily because they cover a lot of ground. Cross-country skiers can go nearly anywhere they please because the snow wipes out the distinctions between public and private land.

Because the low temperatures require one to keep moving, the ski trails become the primary meeting places.

The meeting places in and around the summit house, then, should all be located along primary paths.

There should be at least three such places. One ought to be very near the summit, along the hiking path. One ought to be completely enclosed and heated so that it can be used all year, and should be adjacent to both the hiking path, as it passes through the building, and the winter entry route. The third ought to be





a cul-de-sac adjacent to the ski trail, where skiers can stop and remove their gear before entering the building. A fourth might provide skiers with room to put on their gear before starting down the mountain.

Afterword

It is customary to close documents of this sort with either written or drawn conclusions. To do that here would seem inappropriate, for it would suggest that either the design or the research was finished. In addition, the layman might be left with the impression that whatever was presented was the best or the only solution to the stated problem, remarks to the contrary notwithstanding. Instead, keeping in mind the importance of identifying changes of direction, it is much better to turn the conceptual corner, and point out other avenues of exploration suggested by the ones already described.

It had been intended originally that a second scheme be developed. It was to have contained the same uses as the first, but hikers, rather than skiers, were to be the

dominant users, summer the busiest season. The sites were to have been identical, but the orientation of the second one was to have been southerly, rather than northeasterly.

Whereas the heavy winter use of the building in the first scheme required that most of the interior be heated, the heavier summer use in the second will allow most to be partially or completely unheated. The hearty hikers will probably prefer the cluster of detached living and dining units this permits, to the single large building developed for energy reasons in the other scheme.

Although changes of site, of climate, or of program necessitate the examination of a different set of references and the development of a different set of forms, the under-

Consistency

Alternatives

lying principle remains the same: *greater association with the landscape provides a higher degree of protection.*

Protection in the case of a south-facing slope results from burrowing into the hillside. The resulting form is not only out of the path of downslope winds, but has its exposed roof facing the sun. Even though the short trees near the summit will be unable to shade the building, the



overheating of the interior which results will not be a problem. Fortunately, hikers spend the sunny days, the ones when solar gain is at its greatest, on the trail. The excess daytime heat, however, can be stored in masonry walls and floors. The heat radiated from them as the temperature drops can be used to keep overnight visitors warm.

The territorial glacial cirques described earlier provide useful information about ways of deploying ground forms on a site with a south-erly orientation. At the smaller scale of the summit house, protection from the wind would be at its greatest if one were at the base of a masonry cirque. Movement into an adjacent cirque could happen in either of two ways. One could climb up and over the separating extreme skiing exposure to outdoor conditions, or one could descend to the warmer and more public zones at the floor of a built valley...

APPENDIX

Bibliography

Daumal, Rene: Mount Analogue -- A Novel of Symbolically Authentic Non-Euclidean Adventures in Mountain Climbing, Librairie Gallimard, Paris, France, 1952.

Dueker, Taylor True: Decoration/Intensification/Collage as Definition/Form in Building... Built Form Explorations..., M.I.T. M. Arch. Thesis, Cambridge, Mass., 1977.

"Encouraging Creativity and Celebrating Diversity," Architectural Record, vol. 166, #8, December 1979, p. 98.

Feyerabend, Paul: Against Method -- Outline of an Anarchistic Theory of Knowledge, N.L.B., London, England, 1975.

Joad, C. E. M.: "And of Mountains," Appalachia, vol. 34, mag. #135, December 1962, p. xli.

Matthiessen, Peter: The Snow Leopard, Viking Press, New York, 1978.

McCluggage, Denise: The Centered Skier, Warner Books, New York, 1978.

McPhee, John: Encounters with the Archdruid -- Narratives About a Conservationist and Three of his Natural Enemies, Farrar, Straus, and Giroux, New York, 1971.

Miller, Frank: Design Projections for an Astronomical Observatory, M.I.T. M.Arch. Thesis, Cambridge, Mass., 1979.

Powers of Inhabitation: Observations in the Via Monserrato, M.I.T. Department of Architecture/Grunsfeld Program, Cambridge, Mass., 1978.

Schumacher, E. F.: Small is Beautiful -- Economics as if People Mattered, Harper and Row, New York, 1973.

Sennett, Richard: The Uses of Disorder -- Personal Identity and City Life, Knopf, New York, 1970.

Smith, M. K.: "Not-writing on Built Form (especially 'educational' non-buildings)," Harvard Education Review, vol. 39, #4, p. 69.

Philosophy

Concept

Styron, Charles: Decision Making for Fun, Projective Working Methods, Physical Working Methods, photocopied, Cambridge, Mass., 1976, 1977, and 1978.

Banham, Reyner: The Architecture of the Well-Tempered Environment, The Architectural Press, London, England, 1969.

Cullen, Gordon: The Concise Townscape, Van Nostrand Reinhold Co., New York, 1961.

Dixon, John Morris: "Utopian Mechanism," Progressive Architecture, vol. 58, #8, August 1977, p. 74.

Goldstein, Eliot W.: "A Comparison of Some Unusual Features Found in Japanese and Swiss Carpentry," photocopied, Cambridge, Mass., 1980.

Gutheim, Frederick: "A Livable Winter City," Architectural Record, vol. 165, #2, February 1979, p. 111.

Kauffman, John C.: A Built Form Exploration of Solar Energy, M.I.T. M.Arch. Thesis, Cambridge, Mass., 1975.

Sullivan, Louis H.: The Autobiography of an Idea, Dover Publications, Inc., New York, 1956.

Kepes, Gyorgy, ed.: Structure in Art and in Science, George Braziller, New York, 1965.

Lambeth, James: Solar Designing, privately published, 1977.

"Land Use Planning and Design for Ski Resorts," Architectural Record, vol. 155, #1, January 1974, p.141.

Mahone, Douglas Edward: Buildings and Ground, M.I.T. M.Arch. Thesis, Cambridge, Mass., 1977.

McPhee, John: The Survival of the Bark Canoe, Warner Books, New York, 1975.

Pearce, Peter: Structure in Nature is a Strategy for Design, The M.I.T. Press, Cambridge, Mass., 1978.

Proudman, Robert: Trail Building and Maintenance, Appalachian Mountain Club, Boston, Mass., 1977.

"Ramer: The Alpine/Touring/Ski Mountaineering Binding," Alpine Research, Inc., Golden, Colorado, 1976.

Rapoport, Amos: House Form and Culture, Prentice-Hall, Inc., Englewood Cliffs, New Jersey, 1969.

"Schuss Architecture," Progressive Architecture, vol. 48, #7, July 1967, p. 138.

Scott, Cheryl: "A Step Ahead in Solar Living," Better Homes and Gardens, March 1979, p. 50.

Tuan, Yi-Fu: "Mountains, Ruins, and the Sentiment of Melancholy," Landscape, vol. 14, Autumn 1964, p. 27

Vitruvius: The Ten Books on Architecture, Dover Publications, Inc., New York, 1960.

Allen, Dan H.: Don't Die on the Mountain, Appalachian Mountain Club, Boston, Mass., 1972.

Aronin, Jeffrey Ellis: Climate and Architecture, Reinhold Publishing Corporation, New York, 1953.

Environment

Backcountry Research Program -- A Report on Project Direction and Research Studies, U.S. Department of Agriculture/Forest Service, Fall 1979.

Barry, Allen I.: "Ski Lift Accidents," Appalachia, vol. 34, mag. #137, December 1963, p. 726.

Brower, David, ed.: Wildlands in Our Civilization, Sierra Club, San Francisco, California, 1964.

Brown, David Whipple: Keeping Warm in New England -- A History of Residential Heating from Colonial Times, M.I.T. M.Arch. Thesis, Cambridge, Mass., 1976.

Davies, J. L.: Landforms of Cold Climates -- An Introduction to Systematic Geomorphology, The M.I.T. Press, Cambridge, Mass., 1969.

Geiger, Rudolf: The Climate Near the Ground, Harvard University Press, Cambridge, Mass., 1965.

Glover, Michael, ed.: Conference on Building in Northern Communities: 1973, The Arctic Institute of North America, Montreal, Quebec, January 1974.

Goldstein, Roger Neal: Natural Light in Architectural Design: Element and Determinant, M.I.T. M.Arch. Thesis, Cambridge, Mass., 1976.

Jerome, John: On Mountains -- Thinking About Terrain, McGraw-Hill Book Company, New York, 1979.

Litton, R. Burton, Jr. and Robert J. Tetlow: Water in Landscape -- An Esthetic Overview of the Role of Water in the Landscape, Water Information Center, Inc., Port Washington, New York, 1974.

Martinelli, M., Jr.: letter to the author, February 21, 1980.

Mellor, Malcolm: Blowing Snow, Cold Regions Research and Engineering Laboratory, Hanover, New Hampshire, May 1968.

McHarg, Ian L.: Design with Nature, Doubleday and Company, Inc., Garden City, New York, 1969.

Newbury, William et al., Goals and Policies for Managing Back-country Recreation, Appalachian Mountain Club, Boston, Mass., 1978.

Nicholson, Max: The Environmental Revolution: A Guide for the New Masters of the World, McGraw-Hill Book Company, New York, 1970.

Perla, Ronald I. and M. Martinelli, Jr.: Avalanche Handbook, U.S. Government Printing Office, Washington, D.C., November, 1978.

Alexander, Christopher et al.: A Pattern Language: Towns, Buildings, Construction, Oxford University Press, New York, 1977.

Allen, Edward: Stone Shelters, The M.I.T. Press, Cambridge, Mass., 1969.

Robinson G. and M. C. Baker: Wind-Driven Rain and Buildings, National Research Council of Canada /Division of Building Research, Ottawa, 1975.

"Wind Analysis: Preventive Medicine for Problems," Engineering News-Record, vol. 204, #13, March 27, 1980, p. 26.

Zrudlo, Leo Raymond: The Environmental Design Implications of Arctic Man's Psychological Problems, Laval University M.Arch. Thesis, Quebec, Canada, 1971.

Arctic and Subarctic Construction, Department of the Army, Washington, D.C., July 1971.

"Bridge-Like Structure Adapts a Restaurant to Snow Country," Architectural Record, vol. 157 #3 March 1975, p. 334.

Construction

- Fay, Stephen C. and Stephen K. Rice: Guidelines for Constructing Overnight Backcountry Facilities, U.S. Department of Agriculture/Forest Service, Durham, New Hampshire, Sept. 30, 1977.
- Lane, J. W. et al.: Roof Response to Icing Conditions, Cold Regions Research and Engineering Laboratory, Hanover, New Hampshire, July 1979.
- Latta, J. K.: Walls, Windows, and Roofs for the Canadian Climate: A Summary of the Current Basis for Selection and Design, National Research Council of Canada/Division of Building Research, Ottawa, 1973.
- Mackinlay, Ian and W. E. Willis: Snow Country Design, Mackinlay/Winnacker/McNeil, Architects, Oakland, California.
- Peter, B. and W. R. Shriver: "Snow Loads on Roofs," Canadian Building Digest, January 1963.
- Rush, Richard: "Building in the Path of Nature's Wrath -- Natural Hazard Design," Progressive Architecture, vol. 61, #2, February 1980, p. 106.
- Seike, Kiyosi: The Art of Japanese Joinery, Weatherhill/Tankosa, New York, 1977.
- Shaerer, P. A.: "Control of Snow Drifting About Buildings," Canadian Building Digest, February 1972.
- Sloat, Bruce P.: "Construction at Carter Notch in 1962," Appalachia, vol. 34, mag. #135, December 1962, p. 307.
- Smith, Alan A.: "The Mount Washington Observatory," Appalachia, vol. 34, mag. #134, June 1962, p. 26.
- Smith, Clyde H.: "Igloos on Mount Washington," Appalachia, vol. 34, mag. #137, December 1963, p. 716.

Smith, G. E. Kidder: Switzerland Builds -- Its Native and Modern Architecture, Albert Bonnier, Stockholm, Sweden, March 1949.

"Snowbird: In Scale with the Mountains," Architectural Record, vol. 155, #3, March 1974, p. 119.

Tobiasson, Wayne and John Ricard: Moisture Gain and Its Thermal Consequences for Common Roof Insulation, Cold Regions Research and Engineering Laboratory, Hanover, New Hampshire, April 1979.

Arnheim, Rudolf: "Gestalt Psychology and Artistic Form," Aspects of Form, Lund Humphries, Publishers, London, England, 1968.

Billington, David P.: Robert Mallart's Bridges: The Art of Engineering, Princeton University Press, Princeton, New Jersey, 1979.

Borras, Maria Lluisa: Arquitectura Finlandesa En Otaniemi: Alvar Aalto, Heikki Siren, Reima Pietila, Ediciones Poligrafa, S.A., Barcelona, Spain, 1967.

Brower, Kenneth: The Starship and The Canoe, Holt, Rinehart, and Winston, New York, 1978.

Form

- Cardwell, Kenneth H.: Bernard Maybeck: Artisan, Architect, Artist, Peregrine Smith, Inc., Santa Barbara, California, 1977.
- Carver, Normal F., Jr.: Italian Hilltowns, Documan Press, Kalamazoo, Michigan, 1979.
- Cereghini, Mario: Building in the Mountains: Architecture and History, Edizioni del Milione, Milano, Italy, 1957.
- "Construire en Montagne," L'architecture d'Aujourd'hui, vol. 36, #126, June-July 1966, p. 1-71.
- Erskine, Ralph: "Indigenous Architecture: Architecture in the Subarctic Region," Perspecta -- The Yale Architectural Journal, #8, 1963.
- Fay, Stephen C. and Stephen K. Rice: Guidelines for Design and Location of Overnight Backcountry Facilities, U.S. Department of Agriculture/Forest Service, Durham, New Hampshire, September 30, 1977.
- Fleig, Karl: Alvar Aalto, Wittenborn and Company, Scarsdale, New York, 1963.
- Freeman, John Ripley IV: Under the Roof: An Investigation of the Interaction of Rational Building Structure with Enclosed Space, M.I.T. M.Arch. Thesis, Cambridge, Mass., 1980.
- Frutiger, Hans and M. Martinelli, Jr.: A Manual for Planning Structural Control of Avalanches, U.S. Department of Agriculture/Forest Service, Fort Collins, Colorado, May 1966.
- "Galaxis-Symmetrisch," Deutsche Bauzeitung, vol. 104, #1, January 1970, p. 12.
- Goldstein, Eliot W.: Usonia, photocopied, Cambridge, Mass., November 1978.
- Gray, Henry: Gray's Anatomy -- Descriptive and Applied, Longmans, London, England, 1962.
- "Hammerfest, Norway," Byggekunst: Norske Arkitekters Landsfordund, vol. 47, #3, 24 March 1965, p. 74-77.
- Heschong, Lisa: Thermal Delight in Architecture, M.I.T. M.Arch. Thesis, Cambridge, Mass., 1978.

Hitchcock, Henry Russell: In the Nature of Materials: The Buildings of Frank Lloyd Wright 1887-1941, Elek Books, London, England, 1942.

"House in a Box," The Architectural Review, vol. 159, #952, June 1976, p. 381.

Jellicoe, Geoffrey and Susan: The Landscape of Man: Shaping the Environment from Prehistory to the Present Day, Thames and Hudson, London, England, 1975.

Kaufmann, Edgar, Jr.: La Casa Sulla Cascata di Frank Lloyd Wright, Publikompass S.p.A. Settore Periodici, Milano, Italy, 1962.

Knowles, Ralph L.: Energy and Form: An Ecological Approach to Urban Growth, The M.I.T. Press, Cambridge, Mass., 1974.

Mainstone, Rowland: Developments in Structural Form, The M.I.T. Press, Cambridge, Mass., 1975.

Maki, Fumihiko: Investigations in Collective Form, The School of Architecture - Washington University, St. Louis, Missouri, June 1964.

Nervi, Pier Luigi: Buildings, Projects, Structures 1953-1963, Frederick A. Praeger, New York, 1963.

Nicolin, Pier Luigi: "Urbino," LOTUS International - Quarterly Architectural Review, March 1978.

Olgay, Victor: Design with Climate -- A Bioclimatic Approach to Architectural Regionalism, Princeton University Press, Princeton, New Jersey, 1963.

Rudofsky, Bernard: Architecture without Architects, Doubleday and Company, Garden City, New York, 1964.

Sargent, John: Frank Lloyd Wright's Usonian Houses -- The Case for Organic Architecture, Watson-Guptill Publications, New York, 1976.

Schmertz, Mildred F.: "A New Museum by Walter Netsch of S.O.M. Given Order by his Field Theory," Architectural Record, vol. 167, #1, January 1980, p. 111.

Simpson, William: Architecture in the Himalayas -- F.R.I.B.A. Transactions 1882-1883, Susil Gupta, New York, 1970.

Sloan, William Henderson, Jr.: Form Generation through Filmed References: Charles River Baths, M.I.T. M.Arch. Thesis, Cambridge, Mass., 1977.

Temko, Alan: Eero Saarinen, George Braziller, New York, 1962.

"The Arena Residence -- Richard C. Tremaglio," Processes in Architecture: A Documentation of Six Examples, M.I.T. School of Architecture and Planning, Cambridge, Mass., 1979.

Thompson, D'Arcy Wentworth: On Growth and Form, University Press, Cambridge, England, 1917.

Wolff, Rainer: Hauser am Hang, Verlag Georg D. W. Callwey, Munich, Germany, 1975.

Program

The following program was compiled by the author after having visited a number of summit stations both here and abroad:

<u>Winter Function</u>	<u>Size (ft²)</u>	<u>Summer Function</u>	<u>Size (ft²)</u>
Ski Patrol Room	1500	Summer Shelter	1500
Access into Building	1400	Access through Building	2100
Fireplace/Meeting Room	1200	Fireplace/Meeting Room	1200
Clothes-drying Room	250	Clothes-drying Room	250
Office/Administration	250	Office/Administration	250
Kitchen/Food Storage	2500	Kitchen/Food Storage	1000
Public Restrooms	1000	Public Restrooms	1000
Mechanical Equipment	1000	Mechanical Equipment	1000
Covered Ski Storage	3000		
Snow Vehicle Garage	2000		
Total Formal Dining	8000		
Bagged Lunch Spot	1000		
Lift Station	1000		
Accommodations	7000		
Main Desk	750		
Loading Dock	400		
Meeting Rooms (2 @ 500)	1000		
<hr/>		<hr/>	
TOTAL	33250	TOTAL	8300

Winter

Summer