

Search for WH production with a light Higgs boson decaying to prompt electron-jets in proton–proton collisions at $\sqrt{s} = 7$ TeV with the ATLAS detector

This article has been downloaded from IOPscience. Please scroll down to see the full text article.

2013 New J. Phys. 15 043009

(<http://iopscience.iop.org/1367-2630/15/4/043009>)

View [the table of contents for this issue](#), or go to the [journal homepage](#) for more

Download details:

IP Address: 18.51.3.76

The article was downloaded on 20/06/2013 at 19:28

Please note that [terms and conditions apply](#).

Search for WH production with a light Higgs boson decaying to prompt electron-jets in proton–proton collisions at $\sqrt{s} = 7$ TeV with the ATLAS detector

The ATLAS Collaboration

New Journal of Physics **15** (2013) 043009 (35pp)

Received 18 February 2013

Published 8 April 2013

Online at <http://www.njp.org/>

doi:10.1088/1367-2630/15/4/043009

E-mail: atlas.publications@cern.ch

Abstract. A search is performed for WH production with a light Higgs boson decaying to hidden-sector particles resulting in clusters of collimated electrons, known as electron-jets. The search is performed with 2.04 fb^{-1} of data collected in 2011 with the ATLAS detector at the Large Hadron Collider in proton–proton collisions at $\sqrt{s} = 7$ TeV. One event satisfying the signal selection criteria is observed, which is consistent with the expected background rate. Limits on the product of the WH production cross section and the branching ratio of a Higgs boson decaying to prompt electron-jets are calculated as a function of a Higgs boson mass in the range from 100 to 140 GeV.

Contents

1. Introduction	2
2. The ATLAS detector	4
3. Signal and background simulation	5
4. Data samples and trigger selection	6
5. Event selection and electron-jet reconstruction	6
5.1. W boson selection	6
5.2. Electron-jet pair selection	7
6. Background estimation	8
7. Systematic uncertainties	12
8. Results and interpretation	14
9. Conclusions	15
Acknowledgments	16
References	33

1. Introduction

Recently, the production of a boson with a mass of about 125 GeV has been observed by the ATLAS [1] and CMS [2] collaborations. The observation is compatible with the production and decay of the Standard Model (SM) Higgs boson [3–5] at this mass. Strengthening or rejecting the SM Higgs boson hypothesis is currently of utmost importance and thus a search for non-SM Higgs boson decays is of high interest. In this paper, a search for a Higgs boson decaying to a new hidden sector of particles is presented. The masses and couplings of the hidden-sector particles are chosen such that the Higgs boson decay cascade results in jets consisting exclusively of electrons (‘electron-jets’) and weakly interacting neutral particles [6, 7]. This is the first search performed for this particular channel. Moreover, in addition to a recently discovered state consistent with the SM Higgs boson, there may be other scalar fields that couple to the W boson and decay to electron-jets. These scalars arise in the Higgs boson sector in many extensions of the SM, and electron-jets could be the primary discovery channel for these new states. The search is performed in the Higgs boson mass range between 100 and 140 GeV. The analysis examines the associated Higgs boson production mechanism, $pp \rightarrow WH$, assuming SM couplings between the Higgs boson and the W boson.

Many models of physics beyond the SM contain a light hidden sector, which is composed of as yet unobserved fields that are singlets under the SM group $SU(3) \times SU(2) \times U(1)$ and that can be probed at the Large Hadron Collider (LHC) [6–17]. Models of this hidden sector vary from simple modifications of the SM [12, 13] to models motivated by string theory [14] to so-called unparticle models [15].

In the present analysis two models, discussed in [7], are considered. These differ in the way the Higgs boson decays, either via a three-step cascade (figure 1 left) or a two-step cascade (figure 1 right) to hidden-sector particles. In both models the masses of particles in a hidden-sector cascade are taken to be substantially lower than the Higgs boson mass, thus the Higgs boson decay has a two-jet topology. The models feature a dark photon γ_d that kinetically mixes with the SM photon [16, 17], a neutral weakly interacting stable scalar n_d and two hidden

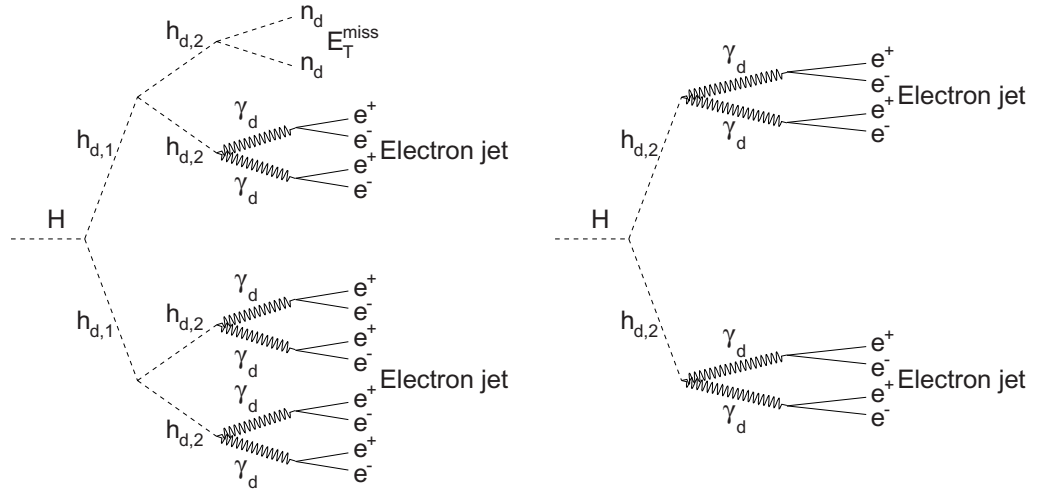

Figure 1. Diagrams illustrating the Higgs boson decay to hidden-sector particles in the (left) three-step and (right) two-step models. Each $h_{d,2}$ particle can decay to a pair of dark photons γ_d or stable scalars n_d , with the corresponding branching ratios given in table 1.

scalars $h_{d,1}$ and $h_{d,2}$. A value of the kinetic mixing parameter ϵ larger than 10^{-5} implies dark photons with very short lifetimes; thus the chosen value of $\epsilon = 10^{-4}$, recommended in [7], ensures that the decay products are prompt. The dark photon mass must be less than 2 GeV for these models to provide a viable explanation of the results of cosmic-ray and dark matter direct-detection experiments [18–21], which observe an unexpected excess of cosmic electrons and/or positrons, while there is no observed proton excess. For a dark photon mass below 210 MeV, the dark photons decay exclusively to e^+e^- pairs; dark photon masses of 100 and 200 MeV are considered in this analysis.

The signal has a distinct two-jet topology with each electron-jet having a multiplicity of ≥ 4 electrons per jet, where the electrons are highly collimated. The specific hidden-sector parameters are given in table 1, and the chosen masses of the Higgs boson are 100, 125 and 140 GeV. The results of the analysis are expected to be robust with respect to the specific choice of the $h_{d,1}$, $h_{d,2}$ and n_d masses as long as these masses are significantly smaller than the Higgs boson mass, i.e. $m_{h_{d,1|2}} \leq 10$ GeV. In particular, as long as the $h_{d,1}$ and $h_{d,2}$ scalars are much lighter than the Higgs boson, the $h_{d,1}$ and $h_{d,2}$ are boosted, and their decay products are collimated, resulting in two distinct electron-jets. Also in the three-step model, the results are expected to be robust against the explicit choice of the branching ratio of the $h_{d,2}$ particle into weakly interacting neutral particles, n_d , as long as this branching ratio is relatively small, i.e. $\text{BR}(h_{d,2} \rightarrow n_d n_d) \leq 0.2$. For this range of branching ratios, both the $h_{d,1}$ particles decay to visible decay products with greater than 90% probability; for larger branching ratios, there will be a considerable fraction of events where only one (or neither) $h_{d,1}$ particle decays to visible decay products.

In this analysis, the W boson produced in association with the Higgs boson is reconstructed in the $W \rightarrow e\nu$ and $W \rightarrow \mu\nu$ decay modes in order to achieve a high efficiency for online event selection and a high signal-to-background ratio. The signal topology is consequently an isolated

Table 1. Parameters of the benchmark hidden-sector models: hidden-sector particle masses, the $\gamma - \gamma_d$ kinetic mixing, and decay branching ratios of $h_{d,1}$ and $h_{d,2}$ in the three-step and two-step models.

Parameter	
$m_{h_{d,1}}$	10 GeV
$m_{h_{d,2}}$	4 GeV
m_{n_d}	90 MeV
m_{γ_d}	100, 200 MeV
ϵ	10^{-4}
Three-step model	
$\text{BR}(h_{d,1} \rightarrow h_{d,2}h_{d,2})$	1
$\text{BR}(h_{d,2} \rightarrow \gamma_d\gamma_d)$	0.8
$\text{BR}(h_{d,2} \rightarrow n_dn_d)$	0.2
Two-step model	
$\text{BR}(h_{d,2} \rightarrow \gamma_d\gamma_d)$	1
$\text{BR}(h_{d,2} \rightarrow n_dn_d)$	0

large transverse momentum lepton accompanied by missing transverse momentum and two or more electron-jets.

The sensitivity of this analysis is approximately two orders of magnitude greater than that of a previous search for similar signatures which was performed by the CDF collaboration [22]. The direct searches for prompt decays of dark photons into electron or muon pairs, as well as a search for a Higgs boson decaying into displaced muon-jets, were reported in [23–26].

2. The ATLAS detector

The ATLAS detector [27] is a multi-purpose particle physics detector with forward–backward symmetric cylindrical geometry¹. The inner detector (ID) provides precise reconstruction of tracks with $|\eta| < 2.5$. It consists of three layers of pixel detectors close to the beam pipe, four layers of silicon microstrip detector modules in the barrel region with pairs of single-sided sensors (SCT) providing 8 hits per track at intermediate radii, and a straw-tube transition radiation tracker (TRT) at the outer radii, providing about 35 hits per track (in the range $|\eta| < 2.0$). The TRT offers substantial discriminating power between electrons and charged hadrons over a wide momentum range (between 0.5 and 100 GeV) via the detection of x-rays produced by transition radiation.

¹ ATLAS uses a right-handed coordinate system with its origin at the nominal pp interaction point at the center of the detector. The positive x -axis is defined by the direction from the interaction point to the center of the LHC ring, with the positive y -axis pointing upwards, while the beam direction defines the z -axis. The azimuthal angle ϕ is measured around the beam axis with the polar angle θ is the angle from the z -axis. The pseudorapidity is defined as $\eta = -\ln \tan(\theta/2)$. The cone separation is defined as $\Delta R = \sqrt{(\Delta\phi)^2 + (\Delta\eta)^2}$. The transverse momentum p_T is defined as the momentum perpendicular to the beam axis: $p_T = \sqrt{p_x^2 + p_y^2}$.

The ID is surrounded by a thin superconducting solenoid providing a 2 T axial magnetic field. A high-granularity lead/liquid-argon (LAr) sampling calorimeter measures the energy and the position of electromagnetic showers with $|\eta| < 3.2$. The total thickness of this calorimeter is more than $24X_0$ in the barrel and above $26X_0$ in the endcaps. LAr sampling calorimeters, with copper or tungsten as absorber, are used to measure hadronic showers in the endcap ($1.5 < |\eta| < 4.9$), while an iron/scintillator tile hadronic calorimeter measures hadronic showers in the central region ($|\eta| < 1.7$). The muon spectrometer (MS) surrounds the calorimeters and consists of three large superconducting air-core toroids, each with eight coils, a system of drift tubes and cathode strip chambers for precision tracking ($|\eta| < 2.7$), and fast tracking chambers for event selection in real time ($|\eta| < 2.4$).

A three-level trigger system [28] selects events to be recorded for offline analysis. The level-1 trigger is implemented in hardware, operating synchronously with the collisions, and uses a subset of detector information to reduce the event rate from 20 MHz to a maximum level-1 output rate of 75 kHz. This is followed by two software-based trigger levels, level-2 and the event filter, which together reduce the recorded event rate to approximately 300 Hz.

3. Signal and background simulation

Simulated data samples are used to estimate the signal acceptance and efficiency, to optimize the signal selection criteria and to cross-check our understanding of the backgrounds. The final background estimate is determined from the data as described in section 6.

The signal Monte Carlo (MC) samples are generated with MADGRAPH [29] to simulate the Higgs boson production and decay to the hidden sector and BRIDGE [30] to simulate the hidden-sector cascades resulting in electron-jets. The output of these two programs is then interfaced to PYTHIA [31] for subsequent hadronization and modeling of the underlying event (UE). All leptonic decay modes of the W boson ($e\nu_e, \mu\nu_\mu, \tau\nu_\tau$) are included in the signal samples.

The most important sources of background are SM W/Z + jets and $t\bar{t}$ processes. A less important source of background comes from pair production of bosons, $WW/ZZ/WZ$, hereafter referred to as diboson production. These processes result in a lepton + jets event topology. In addition, multi-jet events in some instances can be misidentified as W -bosons.

Samples of simulated $W(\rightarrow \ell\nu)$ +jets and $Z(\rightarrow \ell\ell)$ +jets events ($\ell = e/\mu/\tau$) are generated using ALPGEN [32] interfaced to HERWIG [34] for parton shower and fragmentation processes and to JIMMY [35] for UE simulation. In ALPGEN the fixed-order tree-level matrix-element calculations are combined with parton showers using the MLM matching scheme [33]. Simulated samples for $t\bar{t}$ processes are generated with MC@NLO [36] interfaced to HERWIG for parton showering. To study the possible dependence on the specific choice of MC generator, alternate W/Z +jets samples are also generated using SHERPA [37] with an UE modeling according to [38], and alternate top-quark production samples are generated with POWHEG [39] interfaced to PYTHIA for hadronization. The diboson processes are generated with HERWIG. Taus are decayed with TAUOLA [40] in both signal and background samples.

The event yields for $W \rightarrow \ell\nu$, $Z \rightarrow \ell\ell$ ($\ell = e/\mu$) and $t\bar{t}$ processes, which give the largest contribution to background, are scaled using the measured production cross sections [41, 42]. The contributions from $W(\rightarrow \tau\nu)$ and $Z(\rightarrow \tau\tau)$, which are minor sources of background, are obtained using next-to-next-to-leading-order cross-section calculations [43]. The multi-jet background is obtained using normalized data templates [41], since the rate with which

multi-jet events mimic the combined signature of a prompt charged lepton accompanied by missing transverse momentum is difficult to simulate accurately.

The GEANT4 toolkit [44] is used for a detailed simulation of the detector response [45]. The effect of multiple pp interactions per bunch crossing (pile-up) is modeled by overlaying simulated inelastic proton–proton collisions over the original hard-scattering event. The simulated events are then passed through the same reconstruction and analysis chain as the data.

To calibrate the electron energy and to match the resolution of the electron energy and muon momentum observed in data, corrections are applied to electrons in data and electrons and muons in simulated MC samples according to the prescriptions of [46, 47].

4. Data samples and trigger selection

The data sample for this analysis was collected by the ATLAS detector in proton–proton collisions at a center-of-mass energy of 7 TeV in early 2011. The data sample used was required to be recorded during LHC stable-beam conditions when the ATLAS detector components relevant to this analysis were operating within nominal parameters. The total integrated luminosity of the selected data sample is 2.04 fb^{-1} with a 3.7% uncertainty [48, 49].

For the $W \rightarrow e\nu$ channel, at least one reconstructed electron trigger object with transverse energy above 22 GeV in the region of $|\eta| \leq 2.5$ is required. For the $W \rightarrow \mu\nu$ channel, a muon candidate trigger object in the region of $|\eta| \leq 2.4$ having transverse momentum above 18 GeV, reconstructed in both the ID and MS, is required. The muon trigger object must be consistent with having originated from the interaction region.

5. Event selection and electron-jet reconstruction

Signal events are required to have exactly one reconstructed W boson candidate in the $e\nu$ or $\mu\nu$ decay channel and at least two jets identified as electron-jets.

5.1. W boson selection

A W -decay electron candidate is required to pass the tight electron selection criteria [41, 46] with $p_T > 25 \text{ GeV}$ and $|\eta| \leq 2.47$. Electrons in the transition region between the barrel and endcap calorimeters ($1.37 < |\eta| < 1.52$) are rejected. A W -decay muon candidate is required to be identified in both the ID and the MS subsystems and to have $p_T > 20 \text{ GeV}$ and $|\eta| < 2.4$. To increase the robustness against track mis-reconstruction, the difference between the ID and MS p_T measurements is required to be less than 15 GeV [41].

To reduce background from multi-jet events, electron and muon candidates are required to satisfy an isolation criterion: the sum of the p_T of all tracks in a cone of $\Delta R = 0.4$ around the electron (muon) divided by the electron (muon) p_T is required to be less than 0.3 (0.2).

W boson candidates are required to have missing transverse momentum $E_T^{\text{miss}} \geq 25 \text{ GeV}$ and exactly one isolated electron or muon. Events with two or more isolated same-flavor leptons are rejected, substantially reducing the background from Drell–Yan production.

The lepton candidate from the W boson decay is required to match the object that satisfies the trigger selection criteria: the distance between the trigger object and the reconstructed $W \rightarrow \ell\nu$ ($\ell = e/\mu$) lepton is required to be $\Delta R < 0.1$.

To reduce the background from cosmic rays, heavy-flavor production and photon conversions, the W candidate is required to originate from the primary vertex. In events with multiple vertices along the beam axis, the vertex with the largest $\sum p_T^2$, where the sum is over all tracks associated with the vertex, is taken to be the primary vertex of the event. The longitudinal and transverse impact parameters of the charged-lepton track with respect to the primary vertex must be less than 10 and 0.1 mm, respectively.

5.2. Electron-jet pair selection

In this search, the signature of the Higgs boson decay is two or more electron-jets. Electron-jet candidates are formed from jets reconstructed in the calorimeters using an anti- k_r jet clustering algorithm [50] with a radius parameter $R = 0.4$.

The electrons in an electron-jet are too closely collimated to be identified efficiently with the algorithm used to identify electrons from W boson decays. Instead, electron-jets are identified with three discriminating observables, which are described in detail below: the jet electromagnetic fraction (f_{EM}), the jet charged particle fraction (f_{CH}) and the fraction of high-threshold hits originating from transition radiation in the TRT (f_{HT}).

In electron-jets, the electrons typically deposit all of their energy in the electromagnetic calorimeter, so that the fraction of the jet energy deposited in the electromagnetic calorimeter divided by the total jet energy deposited in both the electromagnetic and hadronic calorimeters, f_{EM} , is typically close to unity. The slight degradation of f_{EM} toward lower values is due to the occasional leakage of electromagnetic showers into the hadronic calorimeter, calorimeter noise and electron-jets overlapping with ordinary jets. Hadronic jets reaching the calorimeters mainly consist of π^\pm and photons from π^0 decays. Most π^\pm deposit a sizable fraction of their energy in the hadronic calorimeter, while photons deposit almost all their energy in the electromagnetic calorimeter. The distribution of f_{EM} is further broadened by fluctuations of the electromagnetic and hadronic showers in the detector. The pedestal corrections for noise in the hadronic calorimeter can sometimes lead to reconstructed energies in the hadronic calorimeter that are less than zero, resulting in a value of f_{EM} slightly higher than unity. The simulation models this situation accurately. The distribution of f_{EM} for hadronic jets peaks around 0.85, with a few per cent of these jets having $f_{EM} \geq 0.99$.

Since f_{EM} only provides limited background rejection additional variables are exploited. The quantity f_{CH} is defined as the fraction of the jet energy deposited in calorimeter cells that are associated with tracks within the jet:

$$f_{CH} = \frac{\sum_{\text{'track-cells'}} E^{\text{cell}}}{E^{\text{jet}}}. \quad (1)$$

A track is associated with a jet if it is within a distance of $\Delta R = 0.4$ from the jet axis and has $p_T \geq 400$ MeV. The ‘track-cells’, i.e. calorimeter cells associated with tracks within the jet, consist of the cells within a cone of $\Delta R = 0.2$ around each of the tracks associated with the jet, giving the sum of energy deposits of charged particles within the jet in both the electromagnetic and hadronic calorimeters.

Signal electron-jets consist exclusively of electrons and should have large f_{EM} and f_{CH} . Hadronic jets with large f_{EM} are expected to contain mostly neutral pions decaying to photons and, therefore, fewer charged tracks and low f_{CH} . Photons that convert to electron-positron pairs in the material they traverse before entering the calorimeter increase the value of f_{CH} .

Additional rejection of hadronic jets is achieved by exploiting the identification of electrons using transition radiation. The discriminating quantity is the fraction of TRT hits on a track, f_{HT} , that exceed the high discriminator threshold in the read-out electronics of the TRT straws. Detailed studies of this quantity are reported in [46, 51]. This high-threshold setting corresponds to the size of the large energy deposit from transition radiation in the straw-tube gas. The distribution of f_{HT} for tracks from electrons has a maximum at $f_{\text{HT}} \sim 0.2$, while it peaks at zero and then decreases monotonically for charged hadron tracks. A requirement that $f_{\text{HT}} \geq 0.08$ has an efficiency of over 95% for electrons in the momentum range relevant to this analysis and at the same time effectively rejects charged hadrons. Exploiting the selection criteria described above, a jet is classified as an electron-jet if it satisfies the following requirements:

- jet pseudorapidity $|\eta| \leq 2.0$,
- jet transverse momentum $p_{\text{T}} \geq 30 \text{ GeV}$,
- jet electromagnetic fraction $f_{\text{EM}} \geq 0.99$,
- jet charged particle fraction $f_{\text{CH}} \geq 0.66$ and
- number of tracks associated with the jet $N_{\text{track}} \geq 2$, where the tracks must satisfy the following criteria:
 - track pseudorapidity $|\eta| \leq 2.0$,
 - track transverse momentum $p_{\text{T}} \geq 5 \text{ GeV}$,
 - number of hits in the pixel detector $N_{\text{PIX}} \geq 2$,
 - total number of pixel and SCT hits $N_{\text{PIX}} + N_{\text{SCT}} \geq 7$,
 - fraction of high-threshold TRT hits $f_{\text{HT}} \geq 0.08$.

Good agreement is observed between data and MC simulation in the f_{EM} , f_{CH} and track-related distributions at the different stages of selection, as can be seen in figure 2. The number of events observed in the data and the yields expected for the background and the signal as the selection criteria are applied are shown in table 2. The background yield given here is determined by MC.

6. Background estimation

The dominant background in this search is due to the associated production of a W boson with hadronic jets which mimic the electron-jet signature. Detailed MC studies of the background contamination from hadronic jets faking electron-jets have shown that the high electron content in those jets originates either from final-state photon radiation or from π^0 decays with subsequent photon conversions in the material of the detector. A background prediction from MC simulation would depend on the modeling of final-state photon radiation and parton showering and hadronization, which would introduce large uncertainties in the background rate. Instead, the background contamination in the signal region is estimated from the data using a simplified matrix method [52] which is completely data-driven. Two alternative background estimates were tried and found to be consistent with the matrix method result. One of these estimates—referred to as the ABCD method below—is based on data; the second estimate is based on MC simulation.

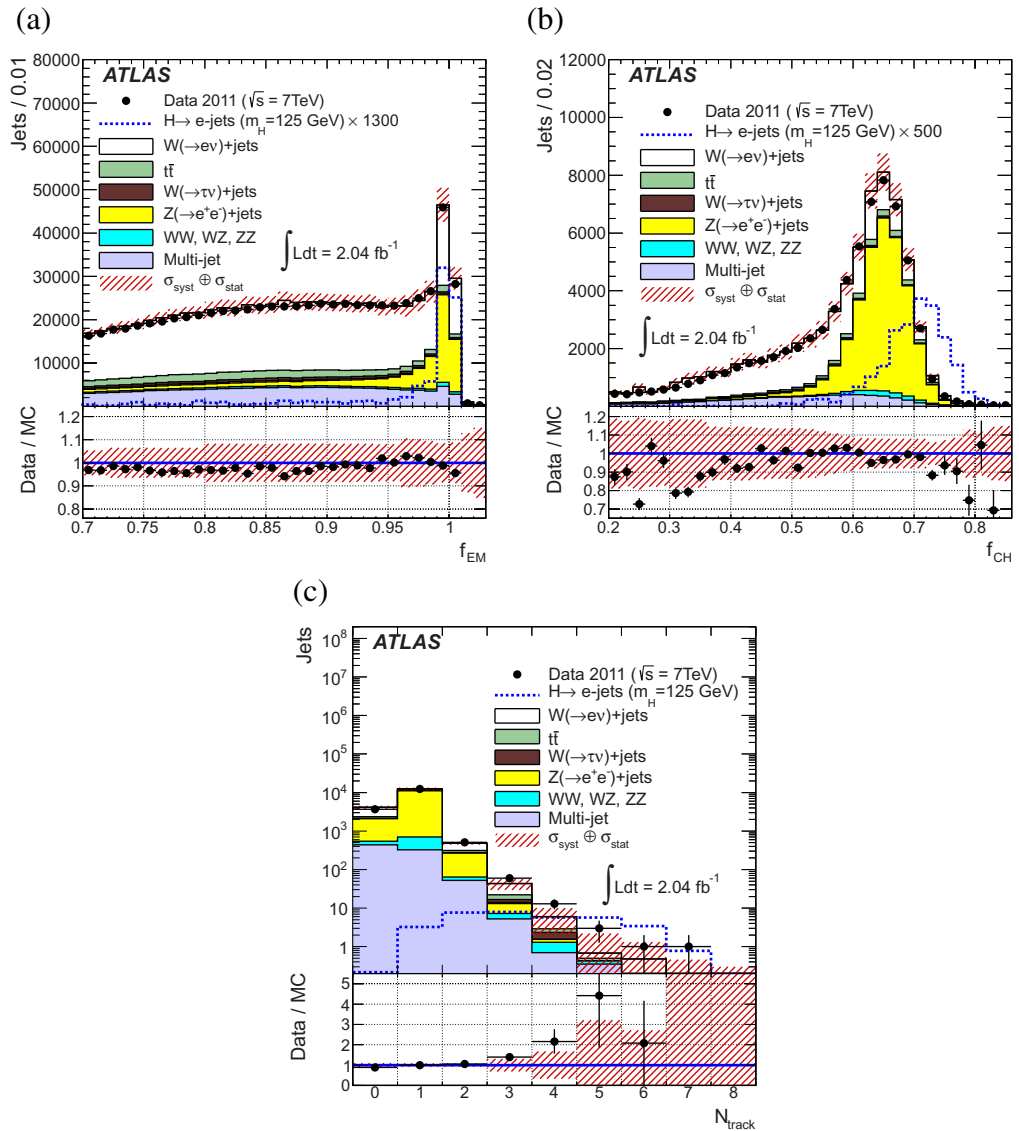

Figure 2. Distribution of the jet electromagnetic fraction, f_{EM} , after the $W \rightarrow e\nu$ selection (a), the jet charged particle fraction, f_{CH} , after the f_{EM} selection (b) and the number of associated tracks, N_{track} , fulfilling the criteria of section 5.2 after the f_{EM} and f_{CH} selection (c). Data are shown by dots with error bars and are compared to the expectation from SM processes, given by stacked histograms of different colors. The signal distributions in the three-step model of a hidden sector with dark photon mass $m_{\gamma_d} = 100\text{ MeV}$ are presented as dashed histograms with arbitrary scale (a and b) and with the nominal scale (c), where nominal scale implies the SM value for WH production cross section and 100% branching ratio of a Higgs boson decaying to electron-jets. The hatched bands represent the quadratic sum of statistical and systematic uncertainties of the SM background prediction described in section 7.

Table 2. The expected number of background and signal events in 2.04 fb^{-1} of data, as well as the number of events observed in the data, after applying the various signal selection criteria for the $W \rightarrow e\nu$ and $W \rightarrow \mu\nu$ channels. The ‘ ≥ 2 jets’ in the first column denotes the requirement of two or more jets per event, satisfying the corresponding selection criteria. The signal predictions correspond to the three-step model with $m_H = 125 \text{ GeV}$ and $m_{\gamma_d} = 100 \text{ MeV}$. The signal efficiencies are the fraction of signal events satisfying all the selection criteria up to and including that particular criterion. They are given with respect to the signal sample including all three decay modes of the W boson ($e\nu_e, \mu\nu_\mu, \tau\nu_\tau$). The background expectations include statistical and systematic uncertainties, and are determined using the MC method (see section 6). The statistical uncertainty shown for the signal is due to MC statistics; the systematic uncertainty is only given for the final event selection and its detailed composition is given in table 4.

	Data	Expected background	Expected signal, $m_H = 125 \text{ GeV}$	Eff.
$W \rightarrow e\nu$ channel				
$W \rightarrow e\nu$ selection	4 351 732	$4\,330\,000 \pm 250\,000$	$46.7 \pm 1.8^{(\text{stat})}$	13%
$p_T \geq 30 \text{ GeV}$,				
$ \eta \leq 2.0$	173 551	$183\,000 \pm 16\,000$	$25.6 \pm 1.4^{(\text{stat})}$	7.1%
≥ 2 jets $f_{EM} \geq 0.99$	837	1070 ± 200	$10.8 \pm 0.9^{(\text{stat})}$	3.0%
$f_{CH} \geq 0.66$	39	35 ± 8	$6.3 \pm 0.7^{(\text{stat})}$	1.7%
$N_{\text{track}} \geq 2$	0	$0.10^{+0.11}_{-0.10}$	$5.3 \pm 0.6^{(\text{stat})} \pm 0.4^{(\text{syst})}$	1.5%
$W \rightarrow \mu\nu$ channel				
$W \rightarrow \mu\nu$ selection	8 870 713	$8\,620\,000 \pm 350\,000$	$60.3 \pm 2.3^{(\text{stat})}$	17%
$p_T \geq 30 \text{ GeV}$,				
$ \eta \leq 2.0$	326 956	$353\,000 \pm 33\,000$	$31.5 \pm 1.7^{(\text{stat})}$	8.8%
≥ 2 jets $f_{EM} \geq 0.99$	1008	1240 ± 180	$13.9 \pm 1.2^{(\text{stat})}$	3.9%
$f_{CH} \geq 0.66$	45	41 ± 16	$7.5 \pm 0.9^{(\text{stat})}$	2.1%
$N_{\text{track}} \geq 2$	1	$0.11^{+0.13}_{-0.11}$	$6.0 \pm 0.8^{(\text{stat})} \pm 0.4^{(\text{syst})}$	1.7%

In the matrix method, one defines a ‘loose’ electron-jet selection criterion by relaxing the minimum track p_T requirement from 5 to 2 GeV. The fraction f is the ratio of the number of jets passing the nominal signal selection N_T to that passing the loose selection N_L :

$$f = \frac{N_T}{N_L}. \quad (2)$$

The number of fake electron-jet background events passing the nominal selection criteria for two electron-jet candidates and entering the signal region is therefore

$$n_{\text{bkgd}} = f^2 n_{\text{fake}}, \quad (3)$$

where n_{fake} is the number of background events passing the loose criterion for both electron-jet candidates. On the other hand, the number of fake electron-jet events in which neither

electron-jet candidate passes the nominal selection criterion is

$$n_{\text{loose}} = (1 - f)^2 n_{\text{fake}}. \quad (4)$$

Combining equations (3) and (4) yields

$$n_{\text{bkgd}} = \frac{f^2}{(1 - f)^2} n_{\text{loose}} = \bar{f}^2 n_{\text{loose}}, \quad (5)$$

where \bar{f} is referred to below as the fake factor. In this way the number of background events is derived directly from the data events failing to pass the nominal criteria for both electron-jet candidates (n_{loose}), where the signal contamination has been checked to be small.

The fake factor \bar{f} is measured from background-enriched data samples where the signal contamination is checked to be completely negligible. The first sample is obtained by reversing the W -candidate electron or muon selection criteria to select a sample of multi-jet background with kinematic characteristics similar to those of the signal sample. A fake factor is obtained from the jets in this sample. In the second sample, the fake factor is determined from a sample of jets that originate from electrons in $Z \rightarrow e^+e^-$ decays. The tight selection criteria and the lepton isolation criteria are applied to one leg of the Z boson candidate, and the invariant mass of this electron and the candidate jet, $m_{e,\text{jet}}$, is required to fall in the range $80 \text{ GeV} < m_{e,\text{jet}} < 100 \text{ GeV}$. The two fake factors are found to be consistent within statistical uncertainties: 0.44 ± 0.02 (stat) and 0.47 ± 0.03 (stat), respectively. The first value is used in the analysis and the difference between these two estimates is taken as a systematic uncertainty in the fake factor. The resulting value is $\bar{f} = 0.44 \pm 0.04$, where the uncertainty is the sum of the statistical and systematic uncertainties added in quadrature.

In the ABCD method used to cross-check the results, events are assigned to one of four regions according to whether or not the jets meet the f_{EM} and the track-quality conditions of the electron-jet classification. These two conditions are chosen because they are less correlated than other selection variables that could have been used. The background yield in the signal region is thus given by

$$n_{\text{bkgd}} = N_{\text{A}}^{\text{predicted}} = \frac{N_{\text{B}}N_{\text{C}}}{N_{\text{D}}} c_{\text{MC}}, \quad (6)$$

where $c_{\text{MC}} = 0.36$ is the correction factor determined from MC simulation that corrects for the effect of the correlations between the two selection criteria. N_i is the number of events observed in region i .

The regions are defined as:

- (A) *Signal region*. Two jets with $f_{\text{EM}} \geq 0.99$ are required; for both jets $N_{\text{track}} \geq 2$, i.e. the number of tracks associated with the candidate jets and fulfilling the requirements of the electron-jet selection must be greater than two (see section 5.2).
- (B) *Anti-track quality region*. At least one jet must fail the associated track requirements of the electron-jet selection. Each of the two candidate jets must have two associated tracks separated by $\Delta R < 0.1$, both tracks satisfying looser requirements $p_{\text{T}} \geq 2 \text{ GeV}$ and $f_{\text{HT}} > 0$. At least one of these tracks must fail the requirement $f_{\text{HT}} > 0.08$.
- (C) *Anti- f_{EM} region*. At least one jet must fail the condition $f_{\text{EM}} \geq 0.99$.
- (D) *Anti-track quality and anti- f_{EM} region*. Both conditions (B) and (C) are fulfilled.

Table 3. Estimated number of background events after the final selection, including statistical and systematic uncertainties, from three different methods. The matrix method is used for the background estimate while the ABCD and MC methods provide a cross-check of the matrix method.

Method of background estimation		Estimated background yield
Matrix	(baseline)	0.41 ± 0.29 (stat) ± 0.12 (syst)
ABCD	(cross-check)	0.46 ± 0.32 (stat) ± 0.10 (syst)
MC	(cross-check)	0.21 ± 0.05 (stat) $^{+0.23}_{-0.21}$ (syst)

Table 4. Systematic uncertainties for the signal. The numbers in parentheses refer to the descriptions in the numbered list in the text. All uncertainties are applied to the combination of $W \rightarrow e\nu$ and $W \rightarrow \mu\nu$ channels; the only exceptions are the specific electron and muon uncertainties in items (iv) and (vii), and are applied separately. The total uncertainty is conservatively rounded and is given for the combination of channels.

	Systematic source	Systematic uncertainty (%)
(i)	MC statistics	13
(ii)	Luminosity	3.7
(iii)	$\sigma \times \text{BR}$	$^{+3.7}_{-4.3}$
(iv)	Electron efficiency	5
(iv)	Muon efficiency	3
(v)	f_{EM} modeling	3
(v)	f_{CH} modeling	0.1
(vi)	f_{HT} modeling	1
(vii)	Electron energy scale	0.5
(vii)	Electron energy resolution	0.2
(vii)	Muon momentum resolution	0.5
(viii)	Pile-up	< 0.1
	Total	15

In the second cross-check of the matrix method, the background prediction is obtained by using data templates and simulated samples with the appropriate cross sections scaled by the measured integrated luminosity, as described in section 3.

The resulting background yields, together with the evaluated statistical and systematic uncertainties, are given in table 3. The estimates from the different background evaluation methods agree well within the uncertainties.

7. Systematic uncertainties

The systematic uncertainties considered for the signal are given in table 4 and described in detail below:

- (i) *MC statistics.* The uncertainty due to the limited number of MC signal events is 13%.
- (ii) *Luminosity.* The uncertainty in the integrated luminosity is determined to be 3.7% [48, 49].

- (iii) *Signal cross sections.* The uncertainty of the SM WH production cross section at Higgs mass $m_H = 125$ GeV is $^{+3.7\%}_{-4.3\%}$ [53]. For 100 and 140 GeV Higgs mass the corresponding uncertainties are $\pm 4\%$ [53].
- (iv) *Electron and muon efficiency.* The combined uncertainty on the efficiency of the lepton trigger, identification and isolation as well as transverse impact parameter requirements is found to be 5% for electrons and 3% for muons. The uncertainties were derived using data-driven methods [46, 47].
- (v) *Jet electromagnetic and charged particle fractions (f_{EM} and f_{CH}).* The uncertainty due to possible mismodeling of these parameters, which impacts the signal acceptance, are studied by comparing the measured f_{EM} and f_{CH} line shape for jets, which are matched to electron from W -decay, to the one predicted by the simulation. They are found to be 3 and 0.1% for f_{EM} and f_{CH} , respectively.
- (vi) *Fraction of high-threshold hits in the TRT (f_{HT}).* Mismodeling of the f_{HT} distribution in the simulation has been previously studied [46, 51]. The impact of this mismodeling on the signal efficiency was checked using the data samples, enriched with highly collimated pairs of electron tracks, and is found to be less than 1%.
- (vii) *Electron and muon energy/momentum scale and resolution.* These uncertainties are evaluated by varying the corresponding correction factors, described in section 5.1, within their systematic uncertainties. This results in the corresponding uncertainties of 0.2, 0.5 and 0.5% for electron/muon energy resolution and electron energy scale respectively.
- (viii) *Pile-up impact.* The effect of additional inelastic collisions overlapping with the primary hard scatter (pile-up) on the signal efficiency has been evaluated using simulated signal samples and found to be negligible.

The systematic uncertainties on the background determinations are estimated in the following ways:

- *Matrix method.* The uncertainty is assessed by varying the fake factor within its uncertainty and is summed in quadrature with the statistical uncertainty on the number of events observed in the loose region. An uncertainty due to possible signal contamination is also taken into account. These result in an 80% uncertainty in the background yield.
- *ABCD method.* The uncertainty is assessed by employing different region selections in the ABCD method and the difference between yields is treated as a systematic uncertainty. The uncertainty due to limited statistics in region B is also considered. The resulting uncertainty in the background yield is 70% with this method.
- *MC method.* The largest contributions to the uncertainty on the background yield are the systematic uncertainty on the MC-based prediction on the probability of two or more jets to be incorrectly identified as electron-jets (100%), modeling of f_{HT} (50%), f_{CH} (10%), f_{EM} (10%), the choice of MC generator (10%) and uncertainties on the cross section for multi-jet processes (10%). The assigned theoretical uncertainties on the cross sections are 4% ($W \rightarrow \ell\nu, Z \rightarrow \ell\ell$), 5% ($W \rightarrow \tau\nu, Z \rightarrow \tau\tau, WZ/ZZ$) and 7% ($t\bar{t}, WW$), respectively [41, 42]. Limited MC sample sizes contributes a 5% uncertainty. The total uncertainty of background estimation with MC method is 110%.

Table 5. Numbers of expected and observed events after final selection. Expected signal yields are provided for both the three-step and two-step models with dark photon masses of 100 and 200 MeV. Statistical (first) and systematic (second) uncertainties are presented separately. The results are given for the combination of the $W \rightarrow e\nu$ and $W \rightarrow \mu\nu$ channels. One candidate event is observed in the data in the $W \rightarrow \mu\nu$ channel.

Signal	Three-step model		Two-step model	
m_H (GeV)	$m_{\gamma_d} = 100$ MeV	$m_{\gamma_d} = 200$ MeV	$m_{\gamma_d} = 100$ MeV	$m_{\gamma_d} = 200$ MeV
100	$14.3 \pm 1.7 \pm 0.8$	$12.4 \pm 1.6 \pm 0.7$	$22.6 \pm 2.1 \pm 1.2$	$23.5 \pm 2.1 \pm 1.2$
125	$11.3 \pm 1.0 \pm 0.6$	$10.7 \pm 1.1 \pm 0.6$	$16.2 \pm 1.2 \pm 0.9$	$18.1 \pm 1.4 \pm 1.0$
140	$9.6 \pm 0.8 \pm 0.5$	$9.0 \pm 0.8 \pm 0.4$	$13.7 \pm 0.9 \pm 0.8$	$13.9 \pm 0.9 \pm 0.8$
Background	$0.41 \pm 0.29 \pm 0.12$			
Data	1			

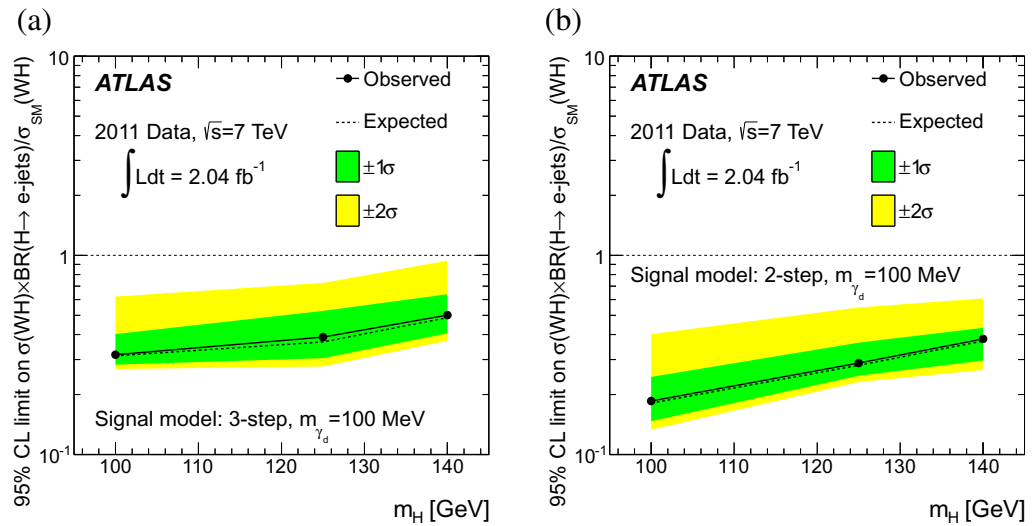

Figure 3. Observed and expected 95% CL upper limits on the signal strength, $\sigma(WH) \times \text{BR}(H \rightarrow e\text{-jets}) / \sigma_{\text{SM}}(WH)$, as a function of the Higgs boson mass for the (left) three-step and (right) two-step models of a hidden sector with a dark photon mass $m_{\gamma_d} = 100$ MeV. The dark (light) shaded band contains 68% (95%) of the outcomes of pseudo-experiments generated under the background-only hypothesis.

8. Results and interpretation

The observed and predicted event yields after the final selection are shown in table 5. The event yield in the signal region is consistent with the background-only hypothesis, with one data event passing the final selection in the $W \rightarrow \mu\nu$ channel and no data events passing the final selection in the $W \rightarrow e\nu$ channel.

Table 6. The 95% confidence level (CL) upper limits on the signal strength, $\sigma(WH) \times \text{BR}(H \rightarrow e\text{-jets})/\sigma_{\text{SM}}(WH)$, for a Higgs boson mass of 125 GeV for different choices of the hidden-sector model parameters. Here, $\sigma(WH)$ is the WH production cross section times the sum of the branching ratios for the W boson decaying to leptons ($e\nu_e, \mu\nu_\mu, \tau\nu_\tau$), $\sigma_{\text{SM}}(WH)$ is the corresponding SM expectation and $\text{BR}(H \rightarrow e\text{-jets})$ is the branching ratio for Higgs boson decays to electron-jets.

Model	m_{γ_d} (MeV)	Observed	Expected
Three-step	100	0.39	0.37
Three-step	200	0.45	0.44
Two-step	100	0.29	0.28
Two-step	200	0.24	0.24

Consequently one estimates a 95% confidence limit on the signal strength, $\sigma(WH) \times \text{BR}(H \rightarrow e\text{-jets})/\sigma_{\text{SM}}(WH)$, where $\sigma(WH)$ denotes the WH production cross section times the sum of the branching ratios for the W boson decaying to leptons ($e\nu_e, \mu\nu_\mu, \tau\nu_\tau$) and $\sigma_{\text{SM}}(WH)$ is the corresponding SM expectation [53] for this quantity ($\sigma_{\text{SM}}(WH) = 223_{-10}^{+8}$ fb for the Higgs boson mass of 125 GeV). $\text{BR}(H \rightarrow e\text{-jets})$ denotes the branching ratio for Higgs boson decays to electron-jets. The results are presented in figure 3 and table 6 for both the three-step and two-step models. Only one limit is presented in figure 3 for each of the two-step and three-step models, because the results are compatible within the statistical uncertainty of the signal for both dark photon masses $m_{\gamma_d} = 100$ and 200 MeV. Limits are derived using the CLs technique [54]. The likelihoods are given by the Poisson distribution for the total number of events in the signal region and are calculated using the number of expected and observed events, whereby the results of the electron and muon channels are summed and enter the likelihood function together. The corresponding signal and background systematic uncertainties are incorporated into the likelihoods as nuisance parameters with Gamma probability density functions [55]. Assuming that the WH cross section has the SM value, for the specific set of hidden-sector parameters chosen here, the analysis excludes Higgs boson branching ratios to electron-jets between 24 and 45% for $m_H = 125$ GeV at 95% CL.

9. Conclusions

A search is presented for a light Higgs boson decaying to a light hidden sector and subsequently into highly collimated jets of electrons, which are expected to be seen in the detector as distinct objects called ‘electron-jets’. The analysis has been performed using 2.04 fb^{-1} of proton–proton collision data at $\sqrt{s} = 7$ TeV, collected with the ATLAS detector at the LHC in 2011.

The search is performed in the WH production mode with the choice of hidden-sector parameter space resulting in Higgs boson decaying into prompt electron-jets. The electron-jet identification method presented here provides good discrimination against background sources and avoids sensitivity to the detailed topology of the electrons within the electron-jet.

The observed data are consistent with the SM background hypothesis. Consequently, 95% CL limits are set on the WH production cross section times the branching ratio into electron-jets,

assuming the two benchmark models of a hidden sector and the condition of a dark photon mass below 210 MeV.

Acknowledgments

We thank CERN for the very successful operation of the LHC, as well as the support staff from our institutions without whom ATLAS could not be operated efficiently. We acknowledge the support of ANPCyT, Argentina; YerPhI, Armenia; ARC, Australia; BMWF and FWF, Austria; ANAS, Azerbaijan; SSTC, Belarus; CNPq and FAPESP, Brazil; NSERC, NRC and CFI, Canada; CERN; CONICYT, Chile; CAS, MOST and NSFC, China; COLCIENCIAS, Colombia; MSMT CR, MPO CR and VSC CR, Czech Republic; DNRF, DNSRC and Lundbeck Foundation, Denmark; EPLANET, ERC and NSRF, European Union; IN2P3-CNRS, CEA-DSM/IRFU, France; GNSF, Georgia; BMBF, DFG, HGF, MPG and AvH Foundation, Germany; GSRT and NSRF, Greece; ISF, MINERVA, GIF, DIP and Benoziyo Center, Israel; INFN, Italy; MEXT and JSPS, Japan; CNRST, Morocco; FOM and NWO, Netherlands; BRF and RCN, Norway; MNiSW, Poland; GRICES and FCT, Portugal; MERYS (MECTS), Romania; MES of Russia and ROSATOM, Russian Federation; JINR; MSTD, Serbia; MSSR, Slovakia; ARRS and MVZT, Slovenia; DST/NRF, South Africa; MICINN, Spain; SRC and Wallenberg Foundation, Sweden; SER, SNSF and Cantons of Bern and Geneva, Switzerland; NSC, Taiwan; TAEK, Turkey; STFC, the Royal Society and Leverhulme Trust, UK; DOE and NSF, USA. The crucial computing support from all WLCG partners is acknowledged gratefully, in particular from CERN and the ATLAS Tier-1 facilities at TRIUMF (Canada), NDGF (Denmark, Norway, Sweden), CC-IN2P3 (France), KIT/GridKA (Germany), INFN-CNAF (Italy), NL-T1 (Netherlands), PIC (Spain), ASGC (Taiwan), RAL (UK) and BNL (USA) and in the Tier-2 facilities worldwide.

The ATLAS Collaboration

G Aad⁴⁸, T Abajyan²¹, B Abbott¹¹¹, J Abdallah¹², S Abdel Khalek¹¹⁵, A A Abdelalim⁴⁹, O Abidinov¹¹, R Aben¹⁰⁵, B Abi¹¹², M Abolins⁸⁸, O S AbouZeid¹⁵⁸, H Abramowicz¹⁵³, H Abreu¹³⁶, B S Acharya^{164a,164b,179}, L Adamczyk³⁸, D L Adams²⁵, T N Addy⁵⁶, J Adelman¹⁷⁶, S Adomeit⁹⁸, P Adragna⁷⁵, T Adye¹²⁹, S Aefsky²³, J A Aguilar-Saavedra^{124b,180}, M Agustoni¹⁷, S P Ahlen²², F Ahles⁴⁸, A Ahmad¹⁴⁸, M Ahsan⁴¹, G Aielli^{133a,133b}, T P A Åkesson⁷⁹, G Akimoto¹⁵⁵, A V Akimov⁹⁴, M A Alam⁷⁶, J Albert¹⁶⁹, S Albrand⁵⁵, M Aleksa³⁰, I N Aleksandrov⁶⁴, F Alessandria^{89a}, C Alexa^{26a}, G Alexander¹⁵³, G Alexandre⁴⁹, T Alexopoulos¹⁰, M Alhroob^{164a,164c}, M Aliev¹⁶, G Alimonti^{89a}, J Alison¹²⁰, B M M Allbrooke¹⁸, L J Allison⁷¹, P P Allport⁷³, S E Allwood-Spiers⁵³, J Almond⁸², A Aloisio^{102a,102b}, R Alon¹⁷², A Alonso³⁶, F Alonso⁷⁰, A Altheimer³⁵, B Alvarez Gonzalez⁸⁸, M G Alviggi^{102a,102b}, K Amako⁶⁵, C Amelung²³, V V Ammosov^{128,216}, S P Amor Dos Santos^{124a}, A Amorim^{124a,181}, S Amoroso⁴⁸, N Amram¹⁵³, C Anastopoulos³⁰, L S Ancu¹⁷, N Andari¹¹⁵, T Andeen³⁵, C F Anders^{58b}, G Anders^{58a}, K J Anderson³¹, A Andreazza^{89a,89b}, V Andrei^{58a}, X S Anduaga⁷⁰, S Angelidakis⁹, P Anger⁴⁴, A Angerami³⁵, F Anghinolfi³⁰, A Anisenkov¹⁰⁷, N Anjos^{124a}, A Annovi⁴⁷, A Antonaki⁹, M Antonelli⁴⁷, A Antonov⁹⁶, J Antos^{144b}, F Anulli^{132a}, M Aoki¹⁰¹, S Aoun⁸³, L Aperio Bella⁵, R Apolle^{118,182}, G Arabidze⁸⁸, I Aracena¹⁴³, Y Arai⁶⁵, A T H Arce⁴⁵, S Arfaoui¹⁴⁸, J-F Arguin⁹³, S Argyropoulos⁴², E Arik^{19a,216}, M Arik^{19a}, A J Armbruster⁸⁷, O Arnaez⁸¹, V Arnal⁸⁰, A Artamonov⁹⁵, G Artoni^{132a,132b}, D Arutinov²¹, S Asai¹⁵⁵, S Ask²⁸, B Åsman^{146a,146b}, L Asquith⁶, K Assamagan^{25,183}, R Astalos^{144a}, A Astbury¹⁶⁹, M Atkinson¹⁶⁵,

B Auerbach⁶, E Auge¹¹⁵, K Augsten¹²⁶, M Arousseau^{145a}, G Avolio³⁰, D Axen¹⁶⁸, G Azuelos^{93,184}, Y Azuma¹⁵⁵, M A Baak³⁰, G Baccaglioni^{89a}, C Bacci^{134a,134b}, A M Bach¹⁵, H Bachacou¹³⁶, K Bachas¹⁵⁴, M Backes⁴⁹, M Backhaus²¹, J Backus Mayes¹⁴³, E Badescu^{26a}, P Bagnaia^{132a,132b}, Y Bai^{33a}, D C Bailey¹⁵⁸, T Bain³⁵, J T Baines¹²⁹, O K Baker¹⁷⁶, S Baker⁷⁷, P Balek¹²⁷, F Balli¹³⁶, E Banas³⁹, P Banerjee⁹³, Sw Banerjee¹⁷³, D Banfi³⁰, A Bangert¹⁵⁰, V Bansal¹⁶⁹, H S Bansil¹⁸, L Barak¹⁷², S P Baranov⁹⁴, T Barber⁴⁸, E L Barberio⁸⁶, D Barberis^{50a,50b}, M Barbero⁸³, D Y Bardin⁶⁴, T Barillari⁹⁹, M Barisonzi¹⁷⁵, T Barklow¹⁴³, N Barlow²⁸, B M Barnett¹²⁹, R M Barnett¹⁵, A Baroncelli^{134a}, G Barone⁴⁹, A J Barr¹¹⁸, F Barreiro⁸⁰, J Barreiro Guimarães da Costa⁵⁷, R Bartoldus¹⁴³, A E Barton⁷¹, V Bartsch¹⁴⁹, A Basye¹⁶⁵, R L Bates⁵³, L Batkova^{144a}, J R Batley²⁸, A Battaglia¹⁷, M Battistin³⁰, F Bauer¹³⁶, H S Bawa^{143,185}, S Beale⁹⁸, T Beau⁷⁸, P H Beauchemin¹⁶¹, R Beccherle^{50a}, P Bechtle²¹, H P Beck¹⁷, K Becker¹⁷⁵, S Becker⁹⁸, M Beckingham¹³⁸, K H Becks¹⁷⁵, A J Beddall^{19c}, A Beddall^{19c}, S Bedikian¹⁷⁶, V A Bednyakov⁶⁴, C P Bee⁸³, L J Beemster¹⁰⁵, M Begel²⁵, S Behar Harpaz¹⁵², C Belanger-Champagne⁸⁵, P J Bell⁴⁹, W H Bell⁴⁹, G Bella¹⁵³, L Bellagamba^{20a}, M Bellomo³⁰, A Belloni⁵⁷, O Beloborodova^{107,186}, K Belotskiy⁹⁶, O Beltramello³⁰, O Benary¹⁵³, D Benchechroun^{135a}, K Bendtz^{146a,146b}, N Benekos¹⁶⁵, Y Benhammou¹⁵³, E Benhar Nocchioli⁴⁹, J A Benitez Garcia^{159b}, D P Benjamin⁴⁵, M Benoit¹¹⁵, J R Bensinger²³, K Benslama¹³⁰, S Bentvelsen¹⁰⁵, D Berge³⁰, E Bergeaas Kuutmann⁴², N Berger⁵, F Berghaus¹⁶⁹, E Berglund¹⁰⁵, J Beringer¹⁵, P Bernat⁷⁷, R Bernhard⁴⁸, C Bernius²⁵, F U Bernlochner¹⁶⁹, T Berry⁷⁶, C Bertella⁸³, A Bertin^{20a,20b}, F Bertolucci^{122a,122b}, M I Besana^{89a,89b}, G J Besjes¹⁰⁴, N Besson¹³⁶, S Bethke⁹⁹, W Bhimji⁴⁶, R M Bianchi³⁰, L Bianchini²³, M Bianco^{72a,72b}, O Biebel⁹⁸, S P Bieniek⁷⁷, K Bierwagen⁵⁴, J Biesiada¹⁵, M Biglietti^{134a}, H Bilokon⁴⁷, M Bindi^{20a,20b}, S Binet¹¹⁵, A Bingul^{19c}, C Bini^{132a,132b}, C Biscarat¹⁷⁸, B Bittner⁹⁹, C W Black¹⁵⁰, J E Black¹⁴³, K M Black²², R E Blair⁶, J-B Blanchard¹³⁶, T Blazek^{144a}, I Bloch⁴², C Blocker²³, J Blocki³⁹, W Blum⁸¹, U Blumenschein⁵⁴, G J Bobbink¹⁰⁵, V S Bobrovnikov¹⁰⁷, S S Bocchetta⁷⁹, A Bocci⁴⁵, C R Boddy¹¹⁸, M Boehler⁴⁸, J Boek¹⁷⁵, T T Boek¹⁷⁵, N Boelaert³⁶, J A Bogaerts³⁰, A Bogdanchikov¹⁰⁷, A Bogouch^{90,216}, C Bohm^{146a}, J Bohm¹²⁵, V Boisvert⁷⁶, T Bold³⁸, V Boldea^{26a}, N M Bolnet¹³⁶, M Bomben⁷⁸, M Bona⁷⁵, M Boonekamp¹³⁶, S Bordon⁷⁸, C Borer¹⁷, A Borisov¹²⁸, G Borissov⁷¹, I Borjanovic^{13a}, M Borri⁸², S Borroni⁴², J Bortfeldt⁹⁸, V Bortolotto^{134a,134b}, K Bos¹⁰⁵, D Boscherini^{20a}, M Bosman¹², H Boterenbrood¹⁰⁵, J Bouchami⁹³, J Boudreau¹²³, E V Bouhova-Thacker⁷¹, D Boumediene³⁴, C Bourdarios¹¹⁵, N Bousson⁸³, S Boutouil^{135d}, A Boveia³¹, J Boyd³⁰, I R Boyko⁶⁴, I Bozovic-Jelisavcic^{13b}, J Bracinik¹⁸, P Branchini^{134a}, A Brandt⁸, G Brandt¹¹⁸, O Brandt⁵⁴, U Bratzler¹⁵⁶, B Brau⁸⁴, J E Brau¹¹⁴, H M Braun^{175,216}, S F Brazzale^{164a,164c}, B Brelrier¹⁵⁸, J Bremer³⁰, K Brendlinger¹²⁰, R Brenner¹⁶⁶, S Bressler¹⁷², T M Bristow^{145b}, D Britton⁵³, F M Brochu²⁸, I Brock²¹, R Brock⁸⁸, F Broggi^{89a}, C Bromberg⁸⁸, J Bronner⁹⁹, G Brooijmans³⁵, T Brooks⁷⁶, W K Brooks^{32b}, G Brown⁸², P A Bruckman de Renstrom³⁹, D Bruncko^{144b}, R Bruneliere⁴⁸, S Brunet⁶⁰, A Bruni^{20a}, G Bruni^{20a}, M Bruschi^{20a}, L Bryngemark⁷⁹, T Buanes¹⁴, Q Buat⁵⁵, F Bucci⁴⁹, J Buchanan¹¹⁸, P Buchholz¹⁴¹, R M Buckingham¹¹⁸, A G Buckley⁴⁶, S I Buda^{26a}, I A Budagov⁶⁴, B Budick¹⁰⁸, L Bugge¹¹⁷, O Bulekov⁹⁶, A C Bundock⁷³, M Bunse⁴³, T Buran¹¹⁷, H Burckhart³⁰, S Burdin⁷³, T Burgess¹⁴, S Burke¹²⁹, E Busato³⁴, V Büscher⁸¹, P Bussey⁵³, C P Buszello¹⁶⁶, B Butler¹⁴³, J M Butler²², C M Buttar⁵³, J M Butterworth⁷⁷, W Buttinger²⁸, M Byszewski³⁰, S Cabrera Urbán¹⁶⁷, D Caforio^{20a,20b}, O Cakir^{4a}, P Calafiura¹⁵, G Calderini⁷⁸, P Calfayan⁹⁸, R Calkins¹⁰⁶, L P Caloba^{24a}, R Caloi^{132a,132b}, D Calvet³⁴, S Calvet³⁴, R Camacho Toro³⁴, P Camarri^{133a,133b}, D Cameron¹¹⁷, L M Caminada¹⁵, R Caminal Armadans¹², S Campana³⁰, M Campanelli⁷⁷, V Canale^{102a,102b}, F Canelli³¹, A Canepa^{159a}, J Cantero⁸⁰, R Cantrill⁷⁶,

T Cao⁴⁰, M D M Capeans Garrido³⁰, I Caprini^{26a}, M Caprini^{26a}, D Capriotti⁹⁹, M Capua^{37a,37b}, R Caputo⁸¹, R Cardarelli^{133a}, T Carli³⁰, G Carlino^{102a}, L Carminati^{89a,89b}, S Caron¹⁰⁴, E Carquin^{32b}, G D Carrillo-Montoya^{145b}, A A Carter⁷⁵, J R Carter²⁸, J Carvalho^{124a,187}, D Casadei¹⁰⁸, M P Casado¹², M Cascella^{122a,122b}, C Caso^{50a,50b,216}, E Castaneda-Miranda¹⁷³, V Castillo Gimenez¹⁶⁷, N F Castro^{124a}, G Cataldi^{72a}, P Catastini⁵⁷, A Catinaccio³⁰, J R Catmore³⁰, A Cattai³⁰, G Cattani^{133a,133b}, S Caughron⁸⁸, V Cavaliere¹⁶⁵, P Cavalleri⁷⁸, D Cavalli^{89a}, M Cavalli-Sforza¹², V Cavasinni^{122a,122b}, F Ceradini^{134a,134b}, A S Cerqueira^{24b}, A Cerri¹⁵, L Cerrito⁷⁵, F Cerutti¹⁵, S A Cetin^{19b}, A Chafaq^{135a}, D Chakraborty¹⁰⁶, I Chalupkova¹²⁷, K Chan³, P Chang¹⁶⁵, B Chapleau⁸⁵, J D Chapman²⁸, J W Chapman⁸⁷, D G Charlton¹⁸, V Chavda⁸², C A Chavez Barajas³⁰, S Cheatham⁸⁵, S Chekanov⁶, S V Chekulaev^{159a}, G A Chelkov⁶⁴, M A Chelstowska¹⁰⁴, C Chen⁶³, H Chen²⁵, S Chen^{33c}, X Chen¹⁷³, Y Chen³⁵, Y Cheng³¹, A Cheplakov⁶⁴, R Cherkaoui El Moursli^{135e}, V Chernyatin²⁵, E Cheu⁷, S L Cheung¹⁵⁸, L Chevalier¹³⁶, G Chiefari^{102a,102b}, L Chikovani^{51a,216}, J T Childers³⁰, A Chilingarov⁷¹, G Chiodini^{72a}, A S Chisholm¹⁸, R T Chislett⁷⁷, A Chitan^{26a}, M V Chizhov⁶⁴, G Choudalakis³¹, S Chouridou⁹, B K B Chow⁹⁸, I A Christidi⁷⁷, A Christov⁴⁸, D Chromek-Burckhart³⁰, M L Chu¹⁵¹, J Chudoba¹²⁵, G Ciapetti^{132a,132b}, A K Ciftci^{4a}, R Ciftci^{4a}, D Cinca⁶², V Cindro⁷⁴, A Ciocio¹⁵, M Cirilli⁸⁷, P Cirkovic^{13b}, Z H Citron¹⁷², M Citterio^{89a}, M Ciubancan^{26a}, A Clark⁴⁹, P J Clark⁴⁶, R N Clarke¹⁵, W Cleland¹²³, J C Clemens⁸³, B Clement⁵⁵, C Clement^{146a,146b}, Y Coadou⁸³, M Cobal^{164a,164c}, A Coccaro¹³⁸, J Cochran⁶³, L Coffey²³, J G Cogan¹⁴³, J Coggeshall¹⁶⁵, J Colas⁵, S Cole¹⁰⁶, A P Colijn¹⁰⁵, N J Collins¹⁸, C Collins-Tooth⁵³, J Collot⁵⁵, T Colombo^{119a,119b}, G Colon⁸⁴, G Compostella⁹⁹, P Conde Muiño^{124a}, E Coniavitis¹⁶⁶, M C Conidi¹², S M Consonni^{89a,89b}, V Consorti⁴⁸, S Constantinescu^{26a}, C Conta^{119a,119b}, G Conti⁵⁷, F Conventi^{102a,188}, M Cooke¹⁵, B D Cooper⁷⁷, A M Cooper-Sarkar¹¹⁸, K Copic¹⁵, T Cornelissen¹⁷⁵, M Corradi^{20a}, F Corriveau^{85,189}, A Cortes-Gonzalez¹⁶⁵, G Cortiana⁹⁹, G Costa^{89a}, M J Costa¹⁶⁷, D Costanzo¹³⁹, D Côté³⁰, G Cottin^{32a}, L Courneyea¹⁶⁹, G Cowan⁷⁶, B E Cox⁸², K Cranmer¹⁰⁸, S Crépe-Renaudin⁵⁵, F Crescioli⁷⁸, M Cristinziani²¹, G Crosetti^{37a,37b}, C-M Cuciuc^{26a}, C Cuenca Almenar¹⁷⁶, T Cuhadar Donszelmann¹³⁹, J Cummings¹⁷⁶, M Curatolo⁴⁷, C J Curtis¹⁸, C Cuthbert¹⁵⁰, P Cwetanski⁶⁰, H Czirr¹⁴¹, P Czodrowski⁴⁴, Z Czczyula¹⁷⁶, S D'Auria⁵³, M D'Onofrio⁷³, A D'Orazio^{132a,132b}, M J Da Cunha Sargedas De Sousa^{124a}, C Da Via⁸², W Dabrowski³⁸, A Dafinca¹¹⁸, T Dai⁸⁷, F Dallaire⁹³, C Dallapiccola⁸⁴, M Dam³⁶, D S Damiani¹³⁷, H O Danielsson³⁰, V Dao¹⁰⁴, G Darbo^{50a}, G L Darlea^{26b}, J A Dassoulas⁴², W Davey²¹, T Davidek¹²⁷, N Davidson⁸⁶, R Davidson⁷¹, E Davies^{118,182}, M Davies⁹³, O Davignon⁷⁸, A R Davison⁷⁷, Y Davygora^{58a}, E Dawe¹⁴², I Dawson¹³⁹, R K Daya-Ishmukhametova²³, K De⁸, R de Asmundis^{102a}, S De Castro^{20a,20b}, S De Cecco⁷⁸, J de Graat⁹⁸, N De Groot¹⁰⁴, P de Jong¹⁰⁵, C De La Taille¹¹⁵, H De la Torre⁸⁰, F De Lorenzi⁶³, L De Nooij¹⁰⁵, D De Pedis^{132a}, A De Salvo^{132a}, U De Sanctis^{164a,164c}, A De Santo¹⁴⁹, J B De Vivie De Regie¹¹⁵, G De Zorzi^{132a,132b}, W J Dearnaley⁷¹, R Debbe²⁵, C Debenedetti⁴⁶, B Dechenaux⁵⁵, D V Dedovich⁶⁴, J Degenhardt¹²⁰, J Del Peso⁸⁰, T Del Prete^{122a,122b}, T Delemontex⁵⁵, M Deliyergiyev⁷⁴, A Dell'Acqua³⁰, L Dell'Asta²², M Della Pietra^{102a,188}, D della Volpe^{102a,102b}, M Delmastro⁵, P A Delsart⁵⁵, C Deluca¹⁰⁵, S Demers¹⁷⁶, M Demichev⁶⁴, B Demirkoz^{12,190}, S P Denisov¹²⁸, D Derendarz³⁹, J E Derkaoui^{135d}, F Derue⁷⁸, P Dervan⁷³, K Desch²¹, P O Deviveiros¹⁰⁵, A Dewhurst¹²⁹, B DeWilde¹⁴⁸, S Dhaliwal¹⁵⁸, R Dhullipudi^{25,191}, A Di Ciaccio^{133a,133b}, L Di Ciaccio⁵, C Di Donato^{102a,102b}, A Di Girolamo³⁰, B Di Girolamo³⁰, S Di Luise^{134a,134b}, A Di Mattia¹⁵², B Di Micco³⁰, R Di Nardo⁴⁷, A Di Simone^{133a,133b}, R Di Sipio^{20a,20b}, M A Diaz^{32a}, E B Diehl⁸⁷, J Dietrich⁴², T A Dietzsch^{58a}, S Diglio⁸⁶,

K Dindar Yagci⁴⁰, J Dingfelder²¹, F Dinut^{26a}, C Dionisi^{132a,132b}, P Dita^{26a}, S Dita^{26a}, F Dittus³⁰, F Djama⁸³, T Djobava^{51b}, M A B do Vale^{24c}, A Do Valle Wemans^{124a,192}, T K O Doan⁵, M Dobbs⁸⁵, D Dobos³⁰, E Dobson⁷⁷, J Dodd³⁵, C Doglioni⁴⁹, T Doherty⁵³, T Dohmae¹⁵⁵, Y Doi^{65,216}, J Dolejsi¹²⁷, Z Dolezal¹²⁷, B A Dolgoshein^{96,216}, M Donadelli^{24d}, J Donini³⁴, J Dopke³⁰, A Doria^{102a}, A Dos Anjos¹⁷³, A Dotti^{122a,122b}, M T Dova⁷⁰, A D Doxiadis¹⁰⁵, A T Doyle⁵³, N Dressnandt¹²⁰, M Dris¹⁰, J Dubbert⁹⁹, S Dube¹⁵, E Dubreuil³⁴, E Duchovni¹⁷², G Duckeck⁹⁸, D Duda¹⁷⁵, A Dudarev³⁰, F Dudziak⁶³, I P Duerdoth⁸², L Duflot¹¹⁵, M-A Dufour⁸⁵, L Duguid⁷⁶, M Dührssen³⁰, M Dunford^{58a}, H Duran Yildiz^{4a}, M Düren⁵², R Duxfield¹³⁹, M Dwuznik³⁸, W L Ebenstein⁴⁵, J Ebke⁹⁸, S Eckweiler⁸¹, W Edson², C A Edwards⁷⁶, N C Edwards⁵³, W Ehrenfeld²¹, T Eifert¹⁴³, G Eigen¹⁴, K Einsweiler¹⁵, E Eisenhandler⁷⁵, T Ekelof¹⁶⁶, M El Kacimi^{135c}, M Ellert¹⁶⁶, S Elles⁵, F Ellinghaus⁸¹, K Ellis⁷⁵, N Ellis³⁰, J Elmsheuser⁹⁸, M Elsing³⁰, D Emelianov¹²⁹, R Engelmann¹⁴⁸, A Engl⁹⁸, B Epp⁶¹, J Erdmann¹⁷⁶, A Ereditato¹⁷, D Eriksson^{146a}, J Ernst², M Ernst²⁵, J Ernwein¹³⁶, D Errede¹⁶⁵, S Errede¹⁶⁵, E Ertel⁸¹, M Escalier¹¹⁵, H Esch⁴³, C Escobar¹²³, X Espinal Curull¹², B Esposito⁴⁷, F Etienne⁸³, A I Etienvre¹³⁶, E Etzion¹⁵³, D Evangelakou⁵⁴, H Evans⁶⁰, L Fabbri^{20a,20b}, C Fabre³⁰, R M Fakhruddinov¹²⁸, S Falciano^{132a}, Y Fang^{33a}, M Fanti^{89a,89b}, A Farbin⁸, A Farilla^{134a}, J Farley¹⁴⁸, T Farooque¹⁵⁸, S Farrell¹⁶³, S M Farrington¹⁷⁰, P Farthouat³⁰, F Fassi¹⁶⁷, P Fassnacht³⁰, D Fassouliotis⁹, B Fatholahzadeh¹⁵⁸, A Favareto^{89a,89b}, L Fayard¹¹⁵, P Federic^{144a}, O L Fedin¹²¹, W Fedorko¹⁶⁸, M Fehling-Kaschek⁴⁸, L Feligioni⁸³, C Feng^{33d}, E J Feng⁶, A B Fenyuk¹²⁸, J Ferencei^{144b}, W Fernando⁶, S Ferrag⁵³, J Ferrando⁵³, V Ferrara⁴², A Ferrari¹⁶⁶, P Ferrari¹⁰⁵, R Ferrari^{119a}, D E Ferreira de Lima⁵³, A Ferrer¹⁶⁷, D Ferrere⁴⁹, C Ferretti⁸⁷, A Ferretto Parodi^{50a,50b}, M Fiascaris³¹, F Fiedler⁸¹, A Filipčić⁷⁴, F Filthaut¹⁰⁴, M Fincke-Keeler¹⁶⁹, M C N Fiolhais^{124a,187}, L Fiorini¹⁶⁷, A Firan⁴⁰, G Fischer⁴², M J Fisher¹⁰⁹, E A Fitzgerald²³, M Flechl⁴⁸, I Fleck¹⁴¹, P Fleischmann¹⁷⁴, S Fleischmann¹⁷⁵, G T Fletcher¹³⁹, G Fletcher⁷⁵, T Flick¹⁷⁵, A Floderus⁷⁹, L R Flores Castillo¹⁷³, A C Florez Bustos^{159b}, M J Flowerdew⁹⁹, T Fonseca Martin¹⁷, A Formica¹³⁶, A Forti⁸², D Fortin^{159a}, D Fournier¹¹⁵, A J Fowler⁴⁵, H Fox⁷¹, P Francavilla¹², M Franchini^{20a,20b}, S Franchino³⁰, D Francis³⁰, T Frank¹⁷², M Franklin⁵⁷, S Franz³⁰, M Fraternali^{119a,119b}, S Fratina¹²⁰, S T French²⁸, C Friedrich⁴², F Friedrich⁴⁴, D Froidevaux³⁰, J A Frost²⁸, C Fukunaga¹⁵⁶, E Fullana Torregrosa¹²⁷, B G Fulsom¹⁴³, J Fuster¹⁶⁷, C Gabaldon³⁰, O Gabizon¹⁷², S Gadatsch¹⁰⁵, T Gadfort²⁵, S Gadomski⁴⁹, G Gagliardi^{50a,50b}, P Gagnon⁶⁰, C Galea⁹⁸, B Galhardo^{124a}, E J Gallas¹¹⁸, V Gallo¹⁷, B J Gallop¹²⁹, P Gallus¹²⁶, K K Gan¹⁰⁹, Y S Gao^{143,185}, A Gaponenko¹⁵, F M Garay Walls⁴⁶, F Garberson¹⁷⁶, C García¹⁶⁷, J E García Navarro¹⁶⁷, M Garcia-Sciveres¹⁵, R W Gardner³¹, N Garelli¹⁴³, V Garonne³⁰, C Gatti⁴⁷, G Gaudio^{119a}, B Gaur¹⁴¹, L Gauthier⁹³, P Gauzzi^{132a,132b}, I L Gavrilenko⁹⁴, C Gay¹⁶⁸, G Gaycken²¹, E N Gazis¹⁰, P Ge^{33d}, Z Gecse¹⁶⁸, C N P Gee¹²⁹, D A A Geerts¹⁰⁵, Ch Geich-Gimbel²¹, K Gellerstedt^{146a,146b}, C Gemme^{50a}, A Gemmell⁵³, M H Genest⁵⁵, S Gentile^{132a,132b}, M George⁵⁴, S George⁷⁶, D Gerbaudo¹², P Gerlach¹⁷⁵, A Gershon¹⁵³, C Geweniger^{58a}, H Ghazlane^{135b}, N Ghodbane³⁴, B Giacobbe^{20a}, S Giagu^{132a,132b}, V Giangiobbe¹², F Gianotti³⁰, B Gibbard²⁵, A Gibson¹⁵⁸, S M Gibson³⁰, M Gilchriese¹⁵, T P S Gillam²⁸, D Gillberg³⁰, A R Gillman¹²⁹, D M Gingrich^{3,184}, J Ginzburg¹⁵³, N Giokaris⁹, M P Giordani^{164c}, R Giordano^{102a,102b}, F M Giorgi¹⁶, P Giovannini⁹⁹, P F Giraud¹³⁶, D Giugni^{89a}, M Giunta⁹³, B K Gjelsten¹¹⁷, L K Gladilin⁹⁷, C Glasman⁸⁰, J Glatzer²¹, A Glazov⁴², G L Glonti⁶⁴, J R Goddard⁷⁵, J Godfrey¹⁴², J Godlewski³⁰, M Goebel⁴², C Goeringer⁸¹, S Goldfarb⁸⁷, T Golling¹⁷⁶, D Golubkov¹²⁸, A Gomes^{124a,181}, L S Gomez Fajardo⁴², R Gonçalo⁷⁶, J Goncalves Pinto Firmino Da Costa⁴², L Gonella²¹, S González de la Hoz¹⁶⁷,

G Gonzalez Parra¹², M L Gonzalez Silva²⁷, S Gonzalez-Sevilla⁴⁹, J J Goodson¹⁴⁸, L Goossens³⁰, T Göpfert⁴⁴, P A Gorbounov⁹⁵, H A Gordon²⁵, I Gorelov¹⁰³, G Gorfine¹⁷⁵, B Gorini³⁰, E Gorini^{72a,72b}, A Gorišek⁷⁴, E Gornicki³⁹, A T Goshaw⁶, M Gosselink¹⁰⁵, C Gössling⁴³, M I Gostkin⁶⁴, I Gough Eschrich¹⁶³, M Gouighri^{135a}, D Goujdami^{135c}, M P Goulette⁴⁹, A G Goussiou¹³⁸, C Goy⁵, S Gozpinar²³, I Grabowska-Bold³⁸, P Grafström^{20a,20b}, K-J Grahn⁴², E Gramstad¹¹⁷, F Grancagnolo^{72a}, S Grancagnolo¹⁶, V Grassi¹⁴⁸, V Gratchev¹²¹, H M Gray³⁰, J A Gray¹⁴⁸, E Graziani^{134a}, O G Grebenyuk¹²¹, T Greenshaw⁷³, Z D Greenwood^{25,191}, K Gregersen³⁶, I M Gregor⁴², P Grenier¹⁴³, J Griffiths⁸, N Grigalashvili⁶⁴, A A Grillo¹³⁷, K Grimm⁷¹, S Grinstein¹², Ph Gris³⁴, Y V Grishkevich⁹⁷, J-F Grivaz¹¹⁵, A Grohsjean⁴², E Gross¹⁷², J Grosse-Knetter⁵⁴, J Groth-Jensen¹⁷², K Grybel¹⁴¹, D Guest¹⁷⁶, O Gueta¹⁵³, C Guicheney³⁴, E Guido^{50a,50b}, T Guillemin¹¹⁵, S Guindon⁵⁴, U Gul⁵³, J Gunther¹²⁵, B Guo¹⁵⁸, J Guo³⁵, P Gutierrez¹¹¹, N Guttman¹⁵³, O Gutzwiller¹⁷³, C Guyot¹³⁶, C Gwenlan¹¹⁸, C B Gwilliam⁷³, A Haas¹⁰⁸, S Haas³⁰, C Haber¹⁵, H K Hadavand⁸, D R Hadley¹⁸, P Haefner²¹, Z Hajduk³⁹, H Hakobyan¹⁷⁷, D Hall¹¹⁸, G Halladjian⁶², K Hamacher¹⁷⁵, P Hamal¹¹³, K Hamano⁸⁶, M Hamer⁵⁴, A Hamilton^{145b,193}, S Hamilton¹⁶¹, L Han^{33b}, K Hanagaki¹¹⁶, K Hanawa¹⁶⁰, M Hance¹⁵, C Handel⁸¹, P Hanke^{58a}, J R Hansen³⁶, J B Hansen³⁶, J D Hansen³⁶, P H Hansen³⁶, P Hansson¹⁴³, K Hara¹⁶⁰, T Harenberg¹⁷⁵, S Harkusha⁹⁰, D Harper⁸⁷, R D Harrington⁴⁶, O M Harris¹³⁸, J Hartert⁴⁸, F Hartjes¹⁰⁵, T Haruyama⁶⁵, A Harvey⁵⁶, S Hasegawa¹⁰¹, Y Hasegawa¹⁴⁰, S Hassani¹³⁶, S Haug¹⁷, M Hauschild³⁰, R Hauser⁸⁸, M Havranek²¹, C M Hawkes¹⁸, R J Hawkins³⁰, A D Hawkins⁷⁹, T Hayakawa⁶⁶, T Hayashi¹⁶⁰, D Hayden⁷⁶, C P Hays¹¹⁸, H S Hayward⁷³, S J Haywood¹²⁹, S J Head¹⁸, T Heck⁸¹, V Hedberg⁷⁹, L Heelan⁸, S Heim¹²⁰, B Heinemann¹⁵, S Heisterkamp³⁶, L Helary²², C Heller⁹⁸, M Heller³⁰, S Hellman^{146a,146b}, D Hellmich²¹, C Helsens¹², R C W Henderson⁷¹, M Henke^{58a}, A Henrichs¹⁷⁶, A M Henriques Correia³⁰, S Henrot-Versille¹¹⁵, C Hensel⁵⁴, C M Hernandez⁸, Y Hernández Jiménez¹⁶⁷, R Herrberg¹⁶, G Herten⁴⁸, R Hertenberger⁹⁸, L Hervas³⁰, G G Hesketh⁷⁷, N P Hessey¹⁰⁵, R Hickling⁷⁵, E Higón-Rodríguez¹⁶⁷, J C Hill²⁸, K H Hiller⁴², S Hillert²¹, S J Hillier¹⁸, I Hinchliffe¹⁵, E Hines¹²⁰, M Hirose¹¹⁶, F Hirsch⁴³, D Hirschbuehl¹⁷⁵, J Hobbs¹⁴⁸, N Hod¹⁵³, M C Hodgkinson¹³⁹, P Hodgson¹³⁹, A Hoecker³⁰, M R Hoeferkamp¹⁰³, J Hoffman⁴⁰, D Hoffmann⁸³, M Hohlfeld⁸¹, S O Holmgren^{146a}, T Holy¹²⁶, J L Holzbauer⁸⁸, T M Hong¹²⁰, L Hooft van Huysduynen¹⁰⁸, S Horner⁴⁸, J-Y Hostachy⁵⁵, S Hou¹⁵¹, A Hoummada^{135a}, J Howard¹¹⁸, J Howarth⁸², M Hrabovsky¹¹³, I Hristova¹⁶, J Hrivnac¹¹⁵, T Hryn'ova⁵, P J Hsu⁸¹, S-C Hsu¹³⁸, D Hu³⁵, Z Hubacek³⁰, F Hubaut⁸³, F Huegging²¹, A Huettmann⁴², T B Huffman¹¹⁸, E W Hughes³⁵, G Hughes⁷¹, M Huhtinen³⁰, T A Hülsing⁸¹, M Hurwitz¹⁵, N Huseynov^{64,194}, J Huston⁸⁸, J Huth⁵⁷, G Iacobucci⁴⁹, G Iakovidis¹⁰, M Ibbotson⁸², I Ibragimov¹⁴¹, L Iconomidou-Fayard¹¹⁵, J Idarraga¹¹⁵, P Iengo^{102a}, O Igonkina¹⁰⁵, Y Ikegami⁶⁵, K Ikematsu¹⁴¹, M Ikeno⁶⁵, D Iliadis¹⁵⁴, N Ilic¹⁵⁸, T Ince⁹⁹, P Ioannou⁹, M Iodice^{134a}, K Iordanidou⁹, V Ippolito^{132a,132b}, A Irlles Quiles¹⁶⁷, C Isaksson¹⁶⁶, M Ishino⁶⁷, M Ishitsuka¹⁵⁷, R Ishmukhametov¹⁰⁹, C Issever¹¹⁸, S Istin^{19a}, A V Ivashin¹²⁸, W Iwanski³⁹, H Iwasaki⁶⁵, J M Izen⁴¹, V Izzo^{102a}, B Jackson¹²⁰, J N Jackson⁷³, P Jackson¹, M R Jaekel³⁰, V Jain², K Jakobs⁴⁸, S Jakobsen³⁶, T Jakoubek¹²⁵, J Jakubek¹²⁶, D O Jamin¹⁵¹, D K Jana¹¹¹, E Jansen⁷⁷, H Jansen³⁰, J Janssen²¹, A Jantsch⁹⁹, M Janus⁴⁸, R C Jared¹⁷³, G Jarlskog⁷⁹, L Jeanty⁵⁷, G-Y Jeng¹⁵⁰, I Jen-La Plante³¹, D Jennens⁸⁶, P Jenni³⁰, P Jež³⁶, S Jézéquel⁵, M K Jha^{20a}, H Ji¹⁷³, W Ji⁸¹, J Jia¹⁴⁸, Y Jiang^{33b}, M Jimenez Belenguer⁴², S Jin^{33a}, O Jinnouchi¹⁵⁷, M D Joergensen³⁶, D Joffe⁴⁰, M Johansen^{146a,146b}, K E Johansson^{146a}, P Johansson¹³⁹, S Johnert⁴², K A Johns⁷, K Jon-And^{146a,146b}, G Jones¹⁷⁰, R W L Jones⁷¹, T J Jones⁷³, C Joram³⁰, P M Jorge^{124a}, K D Joshi⁸², J Jovicevic¹⁴⁷, T Jovin^{13b}, X Ju¹⁷³,

C A Jung⁴³, R M Jungst³⁰, V Juranek¹²⁵, P Jussel⁶¹, A Juste Rozas¹², S Kabana¹⁷, M Kaci¹⁶⁷, A Kaczmarzka³⁹, P Kadlecik³⁶, M Kado¹¹⁵, H Kagan¹⁰⁹, M Kagan⁵⁷, E Kajomovitz¹⁵², S Kalinin¹⁷⁵, L V Kalinovskaya⁶⁴, S Kama⁴⁰, N Kanaya¹⁵⁵, M Kaneda³⁰, S Kaneti²⁸, T Kanno¹⁵⁷, V A Kantserov⁹⁶, J Kanzaki⁶⁵, B Kaplan¹⁰⁸, A Kapliy³¹, D Kar⁵³, M Karagounis²¹, K Karakostas¹⁰, M Karnevskiy^{58b}, V Kartvelishvili⁷¹, A N Karyukhin¹²⁸, L Kashif¹⁷³, G Kasieczka^{58b}, R D Kass¹⁰⁹, A Kastanas¹⁴, Y Kataoka¹⁵⁵, J Katzy⁴², V Kaushik⁷, K Kawagoe⁶⁹, T Kawamoto¹⁵⁵, G Kawamura⁸¹, S Kazama¹⁵⁵, V F Kazanin¹⁰⁷, M Y Kazarinov⁶⁴, R Keeler¹⁶⁹, P T Keener¹²⁰, R Kehoe⁴⁰, M Keil⁵⁴, J S Keller¹³⁸, M Kenyon⁵³, H Keoshkerian⁵, O Kepka¹²⁵, N Kerschen³⁰, B P Kerševan⁷⁴, S Kersten¹⁷⁵, K Kessoku¹⁵⁵, J Keung¹⁵⁸, F Khalil-zada¹¹, H Khandanyan^{146a,146b}, A Khanov¹¹², D Kharchenko⁶⁴, A Khodinov⁹⁶, A Khomich^{58a}, T J Khoo²⁸, G Khoriauli²¹, A Khoroshilov¹⁷⁵, V Khovanskiy⁹⁵, E Khramov⁶⁴, J Khubua^{51b}, H Kim^{146a,146b}, S H Kim¹⁶⁰, N Kimura¹⁷¹, O Kind¹⁶, B T King⁷³, M King⁶⁶, R S B King¹¹⁸, J Kirk¹²⁹, A E Kiryunin⁹⁹, T Kishimoto⁶⁶, D Kisieleska³⁸, T Kitamura⁶⁶, T Kittelmann¹²³, K Kiuchi¹⁶⁰, E Kladiva^{144b}, M Klein⁷³, U Klein⁷³, K Kleinknecht⁸¹, M Klemetti⁸⁵, A Klier¹⁷², P Klimek^{146a,146b}, A Klimentov²⁵, R Klingenberg⁴³, J A Klinger⁸², E B Klinkby³⁶, T Klioutchnikova³⁰, P F Klok¹⁰⁴, S Klous¹⁰⁵, E-E Kluge^{58a}, T Kluge⁷³, P Kluit¹⁰⁵, S Kluth⁹⁹, E Kneringer⁶¹, E B F G Knoop⁸³, A Knue⁵⁴, B R Ko⁴⁵, T Kobayashi¹⁵⁵, M Kobel⁴⁴, M Kocian¹⁴³, P Kodys¹²⁷, S Koenig⁸¹, F Koetsveld¹⁰⁴, P Koevesarki²¹, T Koffas²⁹, E Koffeman¹⁰⁵, L A Kogan¹¹⁸, S Kohlmann¹⁷⁵, F Kohn⁵⁴, Z Kohout¹²⁶, T Kohriki⁶⁵, T Koi¹⁴³, H Kolanoski¹⁶, V Kolesnikov⁶⁴, I Koletsou^{89a}, J Koll⁸⁸, A A Komar⁹⁴, Y Komori¹⁵⁵, T Kondo⁶⁵, K Köneke³⁰, A C König¹⁰⁴, T Kono^{42,195}, A I Kononov⁴⁸, R Konoplich^{108,196}, N Konstantinidis⁷⁷, R Kopeliansky¹⁵², S Koperny³⁸, L Köpke⁸¹, A K Kopp⁴⁸, K Korcyl³⁹, K Kordas¹⁵⁴, A Korn⁴⁶, A Korol¹⁰⁷, I Korolkov¹², E V Korolkova¹³⁹, V A Korotkov¹²⁸, O Kortner⁹⁹, S Kortner⁹⁹, V V Kostyukhin²¹, S Kotov⁹⁹, V M Kotov⁶⁴, A Kotwal⁴⁵, C Kourkoumelis⁹, V Kouskoura¹⁵⁴, A Koutsman^{159a}, R Kowalewski¹⁶⁹, T Z Kowalski³⁸, W Kozanecki¹³⁶, A S Kozhin¹²⁸, V Kral¹²⁶, V A Kramarenko⁹⁷, G Kramberger⁷⁴, M W Krasny⁷⁸, A Krasznahorkay¹⁰⁸, J K Kraus²¹, A Kravchenko²⁵, S Kreiss¹⁰⁸, F Krejci¹²⁶, J Kretzschmar⁷³, K Kreutzfeldt⁵², N Krieger⁵⁴, P Krieger¹⁵⁸, K Kroeninger⁵⁴, H Kroha⁹⁹, J Kroll¹²⁰, J Kroseberg²¹, J Krstic^{13a}, U Kruchonak⁶⁴, H Krüger²¹, T Kruker¹⁷, N Krumnack⁶³, Z V Krumshteyn⁶⁴, M K Kruse⁴⁵, T Kubota⁸⁶, S Kuday^{4a}, S Kuehn⁴⁸, A Kugel^{58c}, T Kuhl⁴², V Kukhtin⁶⁴, Y Kulchitsky⁹⁰, S Kuleshov^{32b}, M Kuna⁷⁸, J Kunkle¹²⁰, A Kupco¹²⁵, H Kurashige⁶⁶, M Kurata¹⁶⁰, Y A Kurochkin⁹⁰, V Kus¹²⁵, E S Kuwertz¹⁴⁷, M Kuze¹⁵⁷, J Kvita¹⁴², R Kwee¹⁶, A La Rosa⁴⁹, L La Rotonda^{37a,37b}, L Labarga⁸⁰, S Lablak^{135a}, C Lacasta¹⁶⁷, F Lacava^{132a,132b}, J Lacey²⁹, H Lacker¹⁶, D Lacour⁷⁸, V R Lacuesta¹⁶⁷, E Ladygin⁶⁴, R Lafaye⁵, B Laforge⁷⁸, T Lagouri¹⁷⁶, S Lai⁴⁸, E Laisne⁵⁵, L Lambourne⁷⁷, C L Lampen⁷, W Lampl⁷, E Lancon¹³⁶, U Landgraf⁴⁸, M P J Landon⁷⁵, V S Lang^{58a}, C Lange⁴², A J Lankford¹⁶³, F Lanni²⁵, K Lantzschi³⁰, A Lanza^{119a}, S Laplace⁷⁸, C Lapoire²¹, J F Laporte¹³⁶, T Lari^{89a}, A Larner¹¹⁸, M Lassnig³⁰, P Laurelli⁴⁷, V Lavorini^{37a,37b}, W Lavrijsen¹⁵, P Laycock⁷³, O Le Dortz⁷⁸, E Le Guirriec⁸³, E Le Menedeu¹², T LeCompte⁶, F Ledroit-Guillon⁵⁵, H Lee¹⁰⁵, J S H Lee¹¹⁶, S C Lee¹⁵¹, L Lee¹⁷⁶, M Lefebvre¹⁶⁹, M Legendre¹³⁶, F Legger⁹⁸, C Leggett¹⁵, M Lehmacher²¹, G Lehmann Miotto³⁰, A G Leister¹⁷⁶, M A L Leite^{24d}, R Leitner¹²⁷, D Lellouch¹⁷², B Lemmer⁵⁴, V Lendermann^{58a}, K J C Leney^{145b}, T Lenz¹⁰⁵, G Lenzen¹⁷⁵, B Lenzi³⁰, K Leonhardt⁴⁴, S Leontsinis¹⁰, F Lepold^{58a}, C Leroy⁹³, J-R Lessard¹⁶⁹, C G Lester²⁸, C M Lester¹²⁰, J Levêque⁵, D Levin⁸⁷, L J Levinson¹⁷², A Lewis¹¹⁸, G H Lewis¹⁰⁸, A M Leyko²¹, M Leyton¹⁶, B Li^{33b}, B Li⁸³, H Li¹⁴⁸, H L Li³¹, S Li^{33b,197}, X Li⁸⁷, Z Liang^{118,198}, H Liao³⁴, B Liberti^{133a}, P Lichard³⁰, K Lie¹⁶⁵, W Liebig¹⁴, C Limbach²¹, A Limosani⁸⁶, M Limper⁶², S C Lin^{151,199}, F Linde¹⁰⁵, J T Linnemann⁸⁸,

E Lipeles¹²⁰, A Lipniacka¹⁴, T M Liss¹⁶⁵, D Lissauer²⁵, A Lister⁴⁹, A M Litke¹³⁷, D Liu¹⁵¹, J B Liu^{33b}, L Liu⁸⁷, M Liu^{33b}, Y Liu^{33b}, M Livan^{119a,119b}, S S A Livermore¹¹⁸, A Lleres⁵⁵, J Llorente Merino⁸⁰, S L Lloyd⁷⁵, F Lo Sterzo^{132a,132b}, E Lobodzinska⁴², P Loch⁷, W S Lockman¹³⁷, T Loddenkoetter²¹, F K Loebinger⁸², A E Loevschall-Jensen³⁶, A Loginov¹⁷⁶, C W Loh¹⁶⁸, T Lohse¹⁶, K Lohwasser⁴⁸, M Lokajicek¹²⁵, V P Lombardo⁵, R E Long⁷¹, L Lopes^{124a}, D Lopez Mateos⁵⁷, J Lorenz⁹⁸, N Lorenzo Martinez¹¹⁵, M Losada¹⁶², P Loscutoff¹⁵, M J Losty^{159a,216}, X Lou⁴¹, A Lounis¹¹⁵, K F Loureiro¹⁶², J Love⁶, P A Love⁷¹, A J Lowe^{143,185}, F Lu^{33a}, H J Lubatti¹³⁸, C Luci^{132a,132b}, A Lucotte⁵⁵, D Ludwig⁴², I Ludwig⁴⁸, J Ludwig⁴⁸, F Luehring⁶⁰, W Lukas⁶¹, L Luminari^{132a}, E Lund¹¹⁷, B Lundberg⁷⁹, J Lundberg^{146a,146b}, O Lundberg^{146a,146b}, B Lund-Jensen¹⁴⁷, J Lundquist³⁶, M Lungwitz⁸¹, D Lynn²⁵, E Lytken⁷⁹, H Ma²⁵, L L Ma¹⁷³, G Maccarrone⁴⁷, A Macchiolo⁹⁹, B Maček⁷⁴, J Machado Miguens^{124a}, D Macina³⁰, R Mackeprang³⁶, R Madar⁴⁸, R J Madaras¹⁵, H J Maddocks⁷¹, W F Mader⁴⁴, A Madsen¹⁶⁶, M Maeno⁵, T Maeno²⁵, L Magnoni¹⁶³, E Magradze⁵⁴, K Mahboubi⁴⁸, J Mahlstedt¹⁰⁵, S Mahmoud⁷³, G Mahout¹⁸, C Maiani¹³⁶, C Maidantchik^{24a}, A Maio^{124a,181}, S Majewski²⁵, Y Makida⁶⁵, N Makovec¹¹⁵, P Mal¹³⁶, B Malaescu⁷⁸, Pa Malecki³⁹, P Malecki³⁹, V P Maleev¹²¹, F Malek⁵⁵, U Mallik⁶², D Malon⁶, C Malone¹⁴³, S Maltezos¹⁰, V Malyshev¹⁰⁷, S Malyukov³⁰, J Mamuzic^{13b}, A Manabe⁶⁵, L Mandelli^{89a}, I Mandić⁷⁴, R Mandrysch⁶², J Maneira^{124a}, A Manfredini⁹⁹, L Manhaes de Andrade Filho^{24b}, J A Manjarres Ramos¹³⁶, A Mann⁹⁸, P M Manning¹³⁷, A Manousakis-Katsikakis⁹, B Mansoulie¹³⁶, R Mantifel⁸⁵, A Mapelli³⁰, L Mapelli³⁰, L March¹⁶⁷, J F Marchand²⁹, F Marchese^{133a,133b}, G Marchiori⁷⁸, M Marcisovsky¹²⁵, C P Marino¹⁶⁹, F Marroquim^{24a}, Z Marshall³⁰, L F Marti¹⁷, S Marti-Garcia¹⁶⁷, B Martin³⁰, B Martin⁸⁸, J P Martin⁹³, T A Martin¹⁸, V J Martin⁴⁶, B Martin dit Latour⁴⁹, H Martinez¹³⁶, M Martinez¹², V Martinez Outschoorn⁵⁷, S Martin-Haugh¹⁴⁹, A C Martyniuk¹⁶⁹, M Marx⁸², F Marzano^{132a}, A Marzin¹¹¹, L Masetti⁸¹, T Mashimo¹⁵⁵, R Mashinistov⁹⁴, J Masik⁸², A L Maslennikov¹⁰⁷, I Massa^{20a,20b}, N Massol⁵, P Mastrandrea¹⁴⁸, A Mastroberardino^{37a,37b}, T Masubuchi¹⁵⁵, H Matsunaga¹⁵⁵, T Matsushita⁶⁶, P Mättig¹⁷⁵, S Mättig⁴², C Mattraversi^{118,182}, J Maurer⁸³, S J Maxfield⁷³, D A Maximov^{107,186}, R Mazini¹⁵¹, M Mazur²¹, L Mazzaferro^{133a,133b}, M Mazzanti^{89a}, J Mc Donald⁸⁵, S P Mc Kee⁸⁷, A McCann¹⁶⁵, R L McCarthy¹⁴⁸, T G McCarthy²⁹, N A McCubbin¹²⁹, K W McFarlane^{56,216}, J A Mcfayden¹³⁹, G Mchedlidze^{51b}, T McLaughlan¹⁸, S J McMahan¹²⁹, R A McPherson^{169,189}, A Meade⁸⁴, J Mechnich¹⁰⁵, M Mechtel¹⁷⁵, M Medinnis⁴², S Meehan³¹, R Meera-Lebbai¹¹¹, T Meguro¹¹⁶, S Mehlhase³⁶, A Mehta⁷³, K Meier^{58a}, C Meineck⁹⁸, B Meirose⁷⁹, C Melachrinou³¹, B R Mellado Garcia¹⁷³, F Meloni^{89a,89b}, L Mendoza Navas¹⁶², Z Meng^{151,200}, A Mengarelli^{20a,20b}, S Menke⁹⁹, E Meoni¹⁶¹, K M Mercurio⁵⁷, P Mermod⁴⁹, L Merola^{102a,102b}, C Meroni^{89a}, F S Merritt³¹, H Merritt¹⁰⁹, A Messina^{30,201}, J Metcalfe²⁵, A S Mete¹⁶³, C Meyer⁸¹, C Meyer³¹, J-P Meyer¹³⁶, J Meyer³⁰, J Meyer⁵⁴, S Michal³⁰, L Micu^{26a}, R P Middleton¹²⁹, S Migas⁷³, L Mijović¹³⁶, G Mikenberg¹⁷², M Mikesstikova¹²⁵, M Mikuš⁷⁴, D W Miller³¹, R J Miller⁸⁸, W J Mills¹⁶⁸, C Mills⁵⁷, A Milov¹⁷², D A Milstead^{146a,146b}, D Milstein¹⁷², G Milutinovic-Dumbelovic^{13a}, A A Minaenko¹²⁸, M Miñano Moya¹⁶⁷, I A Minashvili⁶⁴, A I Mincer¹⁰⁸, B Mindur³⁸, M Mineev⁶⁴, Y Ming¹⁷³, L M Mir¹², G Mirabelli^{132a}, J Mitrevski¹³⁷, V A Mitsou¹⁶⁷, S Mitsui⁶⁵, P S Miyagawa¹³⁹, J U Mjörnmark⁷⁹, T Moa^{146a,146b}, V Moeller²⁸, S Mohapatra¹⁴⁸, W Mohr⁴⁸, R Moles-Valls¹⁶⁷, A Molfetas³⁰, K Mönig⁴², J Monk³⁶, E Monnier⁸³, J Montejo Berlingen¹², F Monticelli⁷⁰, S Monzani^{20a,20b}, R W Moore³, C Mora Herrera⁴⁹, A Moraes⁵³, N Morange⁶², J Morel⁵⁴, D Moreno⁸¹, M Moreno Llácer¹⁶⁷, P Morettini^{50a}, M Morgenstern⁴⁴, M Morii⁵⁷, A K Morley³⁰, G Mornacchi³⁰, J D Morris⁷⁵, L Morvaj¹⁰¹, N Möser²¹, H G Moser⁹⁹, M Mosidze^{51b},

J Moss¹⁰⁹, R Mount¹⁴³, E Mountricha^{10,202}, S V Mouraviev^{94,216}, E J W Moyses⁸⁴, F Mueller^{58a}, J Mueller¹²³, K Mueller²¹, T Mueller⁸¹, D Muenstermann³⁰, T A Müller⁹⁸, Y Munwes¹⁵³, W J Murray¹²⁹, I Mussche¹⁰⁵, E Musto¹⁵², A G Myagkov¹²⁸, M Myska¹²⁵, O Nackenhorst⁵⁴, J Nadal¹², K Nagai¹⁶⁰, R Nagai¹⁵⁷, Y Nagai⁸³, K Nagano⁶⁵, A Nagarkar¹⁰⁹, Y Nagasaka⁵⁹, M Nagel⁹⁹, A M Nairz³⁰, Y Nakahama³⁰, K Nakamura⁶⁵, T Nakamura¹⁵⁵, I Nakano¹¹⁰, H Namasivayam⁴¹, G Nanava²¹, A Napier¹⁶¹, R Narayan^{58b}, M Nash^{77,182}, T Nattermann²¹, T Naumann⁴², G Navarro¹⁶², H A Neal⁸⁷, P Yu Nechaeva⁹⁴, T J Neep⁸², A Negri^{119a,119b}, G Negri³⁰, M Negrini^{20a}, S Nektarijevic⁴⁹, A Nelson¹⁶³, T K Nelson¹⁴³, S Nemecek¹²⁵, P Nemethy¹⁰⁸, A A Nepomuceno^{24a}, M Nessi^{30,203}, M S Neubauer¹⁶⁵, M Neumann¹⁷⁵, A Neusiedl⁸¹, R M Neves¹⁰⁸, P Nevski²⁵, F M Newcomer¹²⁰, P R Newman¹⁸, D H Nguyen⁶, V Nguyen Thi Hong¹³⁶, R B Nickerson¹¹⁸, R Nicolaidou¹³⁶, B Nicquevert³⁰, F Niedercorn¹¹⁵, J Nielsen¹³⁷, N Nikiforou³⁵, A Nikiforov¹⁶, V Nikolaenko¹²⁸, I Nikolic-Audit⁷⁸, K Nikolics⁴⁹, K Nikolopoulos¹⁸, H Nilsen⁴⁸, P Nilsson⁸, Y Ninomiya¹⁵⁵, A Nisati^{132a}, R Nisius⁹⁹, T Nobe¹⁵⁷, L Nodulman⁶, M Nomachi¹¹⁶, I Nomidis¹⁵⁴, S Norberg¹¹¹, M Nordberg³⁰, J Novakova¹²⁷, M Nozaki⁶⁵, L Nozka¹¹³, A-E Nuncio-Quiroz²¹, G Nunes Hanninger⁸⁶, T Nunnemann⁹⁸, E Nurse⁷⁷, B J O'Brien⁴⁶, D C O'Neil¹⁴², V O'Shea⁵³, L B Oakes⁹⁸, F G Oakham^{29,184}, H Oberlack⁹⁹, J Ocariz⁷⁸, A Ochi⁶⁶, M I Ochoa⁷⁷, S Oda⁶⁹, S Odaka⁶⁵, J Odier⁸³, H Ogren⁶⁰, A Oh⁸², S H Oh⁴⁵, C C Ohm³⁰, T Ohshima¹⁰¹, W Okamura¹¹⁶, H Okawa²⁵, Y Okumura³¹, T Okuyama¹⁵⁵, A Olariu^{26a}, A G Olchevski⁶⁴, S A Olivares Pino⁴⁶, M Oliveira^{124a,187}, D Oliveira Damazio²⁵, E Oliver Garcia¹⁶⁷, D Olivito¹²⁰, A Olszewski³⁹, J Olszowska³⁹, A Onofre^{124a,204}, P U E Onyisi^{31,205}, C J Oram^{159a}, M J Oreglia³¹, Y Oren¹⁵³, D Orestano^{134a,134b}, N Orlando^{72a,72b}, C Oropeza Barrera⁵³, R S Orr¹⁵⁸, B Osculati^{50a,50b}, R Ospanov¹²⁰, C Osuna¹², G Otero y Garzon²⁷, J P Ottersbach¹⁰⁵, M Ouchrif^{135d}, E A Ouellette¹⁶⁹, F Ould-Saada¹¹⁷, A Ouraou¹³⁶, Q Ouyang^{33a}, A Ovcharova¹⁵, M Owen⁸², S Owen¹³⁹, V E Ozcan^{19a}, N Ozturk⁸, A Pacheco Pages¹², C Padilla Aranda¹², S Pagan Griso¹⁵, E Paganis¹³⁹, C Pahl⁹⁹, F Paige²⁵, P Pais⁸⁴, K Pajchel¹¹⁷, G Palacino^{159b}, C P Paleari⁷, S Palestini³⁰, D Pallin³⁴, A Palma^{124a}, J D Palmer¹⁸, Y B Pan¹⁷³, E Panagiotopoulou¹⁰, J G Panduro Vazquez⁷⁶, P Pani¹⁰⁵, N Panikashvili⁸⁷, S Panitkin²⁵, D Pantea^{26a}, A Papadelis^{146a}, Th D Papadopoulou¹⁰, A Paramonov⁶, D Paredes Hernandez³⁴, W Park^{25,206}, M A Parker²⁸, F Parodi^{50a,50b}, J A Parsons³⁵, U Parzefall⁴⁸, S Pashapour⁵⁴, E Pasqualucci^{132a}, S Passaggio^{50a}, A Passeri^{134a}, F Pastore^{134a,134b,216}, Fr Pastore⁷⁶, G Pásztor^{49,207}, S Pataraiia¹⁷⁵, N D Patel¹⁵⁰, J R Pater⁸², S Patricelli^{102a,102b}, T Pauly³⁰, J Pearce¹⁶⁹, M Pedersen¹¹⁷, S Pedraza Lopez¹⁶⁷, M I Pedraza Morales¹⁷³, S V Peleganchuk¹⁰⁷, D Pelikan¹⁶⁶, H Peng^{33b}, B Penning³¹, A Penson³⁵, J Penwell⁶⁰, M Perantoni^{24a}, T Perez Cavalcanti⁴², E Perez Codina^{159a}, M T Pérez García-Estañ¹⁶⁷, V Perez Reale³⁵, L Perini^{89a,89b}, H Pernegger³⁰, R Perrino^{72a}, P Perrodo⁵, V D Peshekhonov⁶⁴, K Peters³⁰, R F Y Peters⁵⁴, B A Petersen³⁰, J Petersen³⁰, T C Petersen³⁶, E Petit⁵, A Petridis¹⁵⁴, C Petridou¹⁵⁴, E Petrolo^{132a}, F Petrucci^{134a,134b}, D Petschull⁴², M Petteni¹⁴², R Pezoa^{32b}, A Phan⁸⁶, P W Phillips¹²⁹, G Piacquadio³⁰, A Picazio⁴⁹, E Piccaro⁷⁵, M Piccinini^{20a,20b}, S M Piec⁴², R Piegai²⁷, D T Pignotti¹⁰⁹, J E Pilcher³¹, A D Pilkington⁸², J Pina^{124a,181}, M Pinamonti^{164a,164c,208}, A Pinder¹¹⁸, J L Pinfold³, A Pingel³⁶, B Pinto^{124a}, C Pizio^{89a,89b}, M-A Pleier²⁵, V Pleskot¹²⁷, E Plotnikova⁶⁴, P Plucinski^{146a,146b}, A Poblaguev²⁵, S Poddar^{58a}, F Podlyski³⁴, R Poettgen⁸¹, L Poggioli¹¹⁵, D Pohl²¹, M Pohl⁴⁹, G Polesello^{119a}, A Policicchio^{37a,37b}, R Polifka¹⁵⁸, A Polini^{20a}, J Poll⁷⁵, V Polychronakos²⁵, D Pomeroy²³, K Pommès³⁰, L Pontecorvo^{132a}, B G Pope⁸⁸, G A Popeneciu^{26a}, D S Popovic^{13a}, A Poppleton³⁰, X Portell Bueso³⁰, G E Pospelov⁹⁹, S Pospisil¹²⁶, I N Potrap⁹⁹, C J Potter¹⁴⁹, C T Potter¹¹⁴, G Poulard³⁰, J Poveda⁶⁰, V Pozdnyakov⁶⁴, R Prabhu⁷⁷, P Pralavorio⁸³,

A Pranko¹⁵, S Prasad³⁰, R Pravahan²⁵, S Prell⁶³, K Pretzl¹⁷, D Price⁶⁰, J Price⁷³, L E Price⁶, D Prieur¹²³, M Primavera^{72a}, M Proissl⁴⁶, K Prokofiev¹⁰⁸, F Prokoshin^{32b}, S Protopopescu²⁵, J Proudfoot⁶, X Prudent⁴⁴, M Przybycien³⁸, H Przysieszniak⁵, S Psoroulas²¹, E Ptacek¹¹⁴, E Pueschel⁸⁴, D Puldon¹⁴⁸, M Purohit^{25,206}, P Puzo¹¹⁵, Y Pylypchenko⁶², J Qian⁸⁷, A Quadt⁵⁴, D R Quarrie¹⁵, W B Quayle¹⁷³, M Raas¹⁰⁴, V Radeka²⁵, V Radescu⁴², P Radloff¹¹⁴, F Ragusa^{89a,89b}, G Rahal¹⁷⁸, A M Rahimi¹⁰⁹, S Rajagopalan²⁵, M Rammensee⁴⁸, M Rammes¹⁴¹, A S Randle-Conde⁴⁰, K Randrianarivony²⁹, C Rangel-Smith⁷⁸, K Rao¹⁶³, F Rauscher⁹⁸, T C Rave⁴⁸, T Ravenscroft⁵³, M Raymond³⁰, A L Read¹¹⁷, D M Rebuffi^{119a,119b}, A Redelbach¹⁷⁴, G Redlinger²⁵, R Reece¹²⁰, K Reeves⁴¹, A Reinsch¹¹⁴, I Reisinger⁴³, M Relich¹⁶³, C Rembser³⁰, Z L Ren¹⁵¹, A Renaud¹¹⁵, M Rescigno^{132a}, S Resconi^{89a}, B Resende¹³⁶, P Reznicek⁹⁸, R Rezvani¹⁵⁸, R Richter⁹⁹, E Richter-Was^{5,209}, M Ridel⁷⁸, P Rieck¹⁶, M Rijssenbeek¹⁴⁸, A Rimoldi^{119a,119b}, L Rinaldi^{20a}, R Rios⁴⁰, E Ritsch⁶¹, I Riu¹², G Rivoltella^{89a,89b}, F Rizatdinova¹¹², E Rizvi⁷⁵, S H Robertson^{85,189}, A Robichaud-Veronneau¹¹⁸, D Robinson²⁸, J E M Robinson⁸², A Robson⁵³, J G Rocha de Lima¹⁰⁶, C Roda^{122a,122b}, D Roda Dos Santos³⁰, A Roe⁵⁴, S Roe³⁰, O Røhne¹¹⁷, S Rolli¹⁶¹, A Romaniouk⁹⁶, M Romano^{20a,20b}, G Romeo²⁷, E Romero Adam¹⁶⁷, N Rompotis¹³⁸, L Roos⁷⁸, E Ros¹⁶⁷, S Rosati^{132a}, K Rosbach⁴⁹, A Rose¹⁴⁹, M Rose⁷⁶, G A Rosenbaum¹⁵⁸, P L Rosendahl¹⁴, O Rosenthal¹⁴¹, L Rossetet⁴⁹, V Rossetti¹², E Rossi^{132a,132b}, L P Rossi^{50a}, M Rotaru^{26a}, I Roth¹⁷², J Rothberg¹³⁸, D Rousseau¹¹⁵, C R Royon¹³⁶, A Rozanov⁸³, Y Rozen¹⁵², X Ruan^{33a,210}, F Rubbo¹², I Rubinskiy⁴², N Ruckstuhl¹⁰⁵, V I Rud⁹⁷, C Rudolph⁴⁴, M S Rudolph¹⁵⁸, F Rühr⁷, A Ruiz-Martinez⁶³, L Rumyantsev⁶⁴, Z Rurikova⁴⁸, N A Rusakovich⁶⁴, A Ruschke⁹⁸, J P Rutherford⁷, N Ruthmann⁴⁸, P Ruzicka¹²⁵, Y F Ryabov¹²¹, M Rybar¹²⁷, G Rybkin¹¹⁵, N C Ryder¹¹⁸, A F Saavedra¹⁵⁰, I Sadeh¹⁵³, H F-W Sadrozinski¹³⁷, R Sadykov⁶⁴, F Safai Tehrani^{132a}, H Sakamoto¹⁵⁵, G Salamanna⁷⁵, A Salamon^{133a}, M Saleem¹¹¹, D Salek³⁰, D Salihagic⁹⁹, A Salnikov¹⁴³, J Salt¹⁶⁷, B M Salvachua Ferrando⁶, D Salvatore^{37a,37b}, F Salvatore¹⁴⁹, A Salvucci¹⁰⁴, A Salzburger³⁰, D Sampsonidis¹⁵⁴, A Sanchez^{102a,102b}, J Sánchez¹⁶⁷, V Sanchez Martinez¹⁶⁷, H Sandaker¹⁴, H G Sander⁸¹, M P Sanders⁹⁸, M Sandhoff¹⁷⁵, T Sandoval²⁸, C Sandoval¹⁶², R Sandstroem⁹⁹, D P C Sankey¹²⁹, A Sansoni⁴⁷, C Santamarina Rios⁸⁵, C Santoni³⁴, R Santonico^{133a,133b}, H Santos^{124a}, I Santoyo Castillo¹⁴⁹, K Sapp¹²³, J G Saraiva^{124a}, T Sarangi¹⁷³, E Sarkisyan-Grinbaum⁸, B Sarrazin²¹, F Sarri^{122a,122b}, G Sartisohn¹⁷⁵, O Sasaki⁶⁵, Y Sasaki¹⁵⁵, N Sasao⁶⁷, I Satsounkevitch⁹⁰, G Sauvage^{5,216}, E Sauvan⁵, J B Sauvan¹¹⁵, P Savard^{158,184}, V Savinov¹²³, D O Savu³⁰, L Sawyer^{25,191}, D H Saxon⁵³, J Saxon¹²⁰, C Sbarra^{20a}, A Sbrizzi^{20a,20b}, D A Scannicchio¹⁶³, M Scarcella¹⁵⁰, J Schaarschmidt¹¹⁵, P Schacht⁹⁹, D Schaefer¹²⁰, A Schaelicke⁴⁶, S Schaepe²¹, S Schaetzel^{58b}, U Schäfer⁸¹, A C Schaffer¹¹⁵, D Schaile⁹⁸, R D Schamberger¹⁴⁸, V Scharf^{58a}, V A Schegelsky¹²¹, D Scheirich⁸⁷, M Schernau¹⁶³, M I Scherzer³⁵, C Schiavi^{50a,50b}, J Schieck⁹⁸, M Schioppa^{37a,37b}, S Schlenker³⁰, E Schmidt⁴⁸, K Schmieden²¹, C Schmitt⁸¹, C Schmitt⁹⁸, S Schmitt^{58b}, B Schneider¹⁷, Y J Schnellbach⁷³, U Schnoor⁴⁴, L Schoeffel¹³⁶, A Schoening^{58b}, A L S Schorlemmer⁵⁴, M Schott⁸¹, D Schouten^{159a}, J Schovancova¹²⁵, M Schram⁸⁵, C Schroeder⁸¹, N Schroer^{58c}, M J Schultens²¹, J Schultes¹⁷⁵, H-C Schultz-Coulon^{58a}, H Schulz¹⁶, M Schumacher⁴⁸, B A Schumm¹³⁷, Ph Schune¹³⁶, A Schwartzman¹⁴³, Ph Schwegler⁹⁹, Ph Schwemling¹³⁶, R Schwienhorst⁸⁸, J Schwindling¹³⁶, T Schwindt²¹, M Schwoerer⁵, F G Sciacca¹⁷, E Scifo¹¹⁵, G Sciolla²³, W G Scott¹²⁹, J Searcy¹¹⁴, G Sedov⁴², E Sedykh¹²¹, S C Seidel¹⁰³, A Seiden¹³⁷, F Seifert⁴⁴, J M Seixas^{24a}, G Sekhniaidze^{102a}, S J Sekula⁴⁰, K E Selbach⁴⁶, D M Seliverstov¹²¹, B Sellden^{146a}, G Sellers⁷³, M Seman^{144b}, N Semprini-Cesari^{20a,20b}, C Serfon³⁰, L Serin¹¹⁵, L Serkin⁵⁴, T Serre⁸³, R Seuster^{159a}

H Severini¹¹¹, A Sfyrla³⁰, E Shabalina⁵⁴, M Shamim¹¹⁴, L Y Shan^{33a}, J T Shank²², Q T Shao⁸⁶, M Shapiro¹⁵, P B Shatalov⁹⁵, K Shaw^{164a,164c}, P Sherwood⁷⁷, S Shimizu¹⁰¹, M Shimojima¹⁰⁰, T Shin⁵⁶, M Shiyakova⁶⁴, A Shmeleva⁹⁴, M J Shochet³¹, D Short¹¹⁸, S Shrestha⁶³, E Shulga⁹⁶, M A Shupe⁷, P Sicho¹²⁵, A Sidoti^{132a}, F Siegert⁴⁸, Dj Sijacki^{13a}, O Silbert¹⁷², J Silva^{124a}, Y Silver¹⁵³, D Silverstein¹⁴³, S B Silverstein^{146a}, V Simak¹²⁶, O Simard⁵, Lj Simic^{13a}, S Simion¹¹⁵, E Simioni⁸¹, B Simmons⁷⁷, R Simoniello^{89a,89b}, M Simonyan³⁶, P Sinervo¹⁵⁸, N B Sinev¹¹⁴, V Sipica¹⁴¹, G Siragusa¹⁷⁴, A Sircar²⁵, A N Sisakyan^{64,216}, S Yu Sivoklov⁹⁷, J Sjölin^{146a,146b}, T B Sjørnsen¹⁴, L A Skinnari¹⁵, H P Skottowe⁵⁷, K Skovpen¹⁰⁷, P Skubic¹¹¹, M Slater¹⁸, T Slavicek¹²⁶, K Sliwa¹⁶¹, V Smakhtin¹⁷², B H Smart⁴⁶, L Smestad¹¹⁷, S Yu Smirnov⁹⁶, Y Smirnov⁹⁶, L N Smirnova^{97,211}, O Smirnova⁷⁹, B C Smith⁵⁷, K M Smith⁵³, M Smizanska⁷¹, K Smolek¹²⁶, A A Snesarev⁹⁴, G Snidero⁷⁵, S W Snow⁸², J Snow¹¹¹, S Snyder²⁵, R Sobie^{169,189}, J Sodomka¹²⁶, A Soffer¹⁵³, D A Soh^{151,198}, C A Solans³⁰, M Solar¹²⁶, J Solc¹²⁶, E Yu Soldatov⁹⁶, U Soldevila¹⁶⁷, E Solfaroli Camillocci^{132a,132b}, A A Solodkov¹²⁸, O V Solovyanov¹²⁸, V Solovyev¹²¹, N Soni¹, A Sood¹⁵, V Sopko¹²⁶, B Sopko¹²⁶, M Sosebee⁸, R Soualah^{164a,164c}, P Soueid⁹³, A Soukharev¹⁰⁷, D South⁴², S Spagnolo^{72a,72b}, F Spanò⁷⁶, R Spighi^{20a}, G Spigo³⁰, R Spiwoks³⁰, M Spousta^{127,212}, T Spreitzer¹⁵⁸, B Spurlock⁸, R D St Denis⁵³, J Stahlman¹²⁰, R Stamen^{58a}, E Stanecka³⁹, R W Stanek⁶, C Stanescu^{134a}, M Stanescu-Bellu⁴², M M Stanitzki⁴², S Stapnes¹¹⁷, E A Starchenko¹²⁸, J Stark⁵⁵, P Staroba¹²⁵, P Starovoitov⁴², R Staszewski³⁹, A Staude⁹⁸, P Stavina^{144a,216}, G Steele⁵³, P Steinbach⁴⁴, P Steinberg²⁵, I Stekl¹²⁶, B Stelzer¹⁴², H J Stelzer⁸⁸, O Stelzer-Chilton^{159a}, H Stenzel⁵², S Stern⁹⁹, G A Stewart³⁰, J A Stillings²¹, M C Stockton⁸⁵, M Stoebe⁸⁵, K Stoerig⁴⁸, G Stoicea^{26a}, S Stonjek⁹⁹, P Strachota¹²⁷, A R Stradling⁸, A Straessner⁴⁴, J Strandberg¹⁴⁷, S Strandberg^{146a,146b}, A Strandlie¹¹⁷, M Strang¹⁰⁹, E Strauss¹⁴³, M Strauss¹¹¹, P Strizenec^{144b}, R Ströhmer¹⁷⁴, D M Strom¹¹⁴, J A Strong^{76,216}, R Stroynowski⁴⁰, B Stugu¹⁴, I Stumer^{25,216}, J Stupak¹⁴⁸, P Sturm¹⁷⁵, N A Styles⁴², D Su¹⁴³, H S Subramania³, R Subramaniam²⁵, A Succurro¹², Y Sugaya¹¹⁶, C Suhr¹⁰⁶, M Suk¹²⁷, V V Sulin⁹⁴, S Sultansoy^{4c}, T Sumida⁶⁷, X Sun⁵⁵, J E Sundermann⁴⁸, K Suruliz¹³⁹, G Susinno^{37a,37b}, M R Sutton¹⁴⁹, Y Suzuki⁶⁵, Y Suzuki⁶⁶, M Svatos¹²⁵, S Swedish¹⁶⁸, M Swiatlowski¹⁴³, I Sykora^{144a}, T Sykora¹²⁷, D Ta¹⁰⁵, K Tackmann⁴², A Taffard¹⁶³, R Tafirout^{159a}, N Taiblum¹⁵³, Y Takahashi¹⁰¹, H Takai²⁵, R Takashima⁶⁸, H Takeda⁶⁶, T Takeshita¹⁴⁰, Y Takubo⁶⁵, M Talby⁸³, A Talyshev^{107,186}, J Y C Tam¹⁷⁴, M C Tamsett²⁵, K G Tan⁸⁶, J Tanaka¹⁵⁵, R Tanaka¹¹⁵, S Tanaka¹³¹, S Tanaka⁶⁵, A J Tanasijczuk¹⁴², K Tani⁶⁶, N Tannoury⁸³, S Tapprogge⁸¹, D Tardif¹⁵⁸, S Tarem¹⁵², F Tarrade²⁹, G F Tartarelli^{89a}, P Tas¹²⁷, M Tasevsky¹²⁵, E Tassi^{37a,37b}, Y Tayalati^{135d}, C Taylor⁷⁷, F E Taylor⁹², G N Taylor⁸⁶, W Taylor^{159b}, M Teinturier¹¹⁵, F A Teischinger³⁰, M Teixeira Dias Castanheira⁷⁵, P Teixeira-Dias⁷⁶, K K Temming⁴⁸, H Ten Kate³⁰, P K Teng¹⁵¹, S Terada⁶⁵, K Terashi¹⁵⁵, J Terron⁸⁰, M Testa⁴⁷, R J Teuscher^{158,189}, J Therhaag²¹, T Theveneaux-Pelzer³⁴, S Thoma⁴⁸, J P Thomas¹⁸, E N Thompson³⁵, P D Thompson¹⁸, P D Thompson¹⁵⁸, A S Thompson⁵³, L A Thomsen³⁶, E Thomson¹²⁰, M Thomson²⁸, W M Thong⁸⁶, R P Thun⁸⁷, F Tian³⁵, M J Tibbetts¹⁵, T Tic¹²⁵, V O Tikhomirov⁹⁴, Y A Tikhonov^{107,186}, S Timoshenko⁹⁶, E Tiouchichine⁸³, P Tipton¹⁷⁶, S Tisserant⁸³, T Todorov⁵, S Todorova-Nova¹⁶¹, B Toggerson¹⁶³, J Tojo⁶⁹, S Tokár^{144a}, K Tokushuku⁶⁵, K Tollefson⁸⁸, M Tomoto¹⁰¹, L Tompkins³¹, K Toms¹⁰³, A Tonoyan¹⁴, C Topfel¹⁷, N D Topilin⁶⁴, E Torrence¹¹⁴, H Torres⁷⁸, E Torró Pastor¹⁶⁷, J Toth^{83,207}, F Touchard⁸³, D R Tovey¹³⁹, T Trefzger¹⁷⁴, L Tremblet³⁰, A Tricoli³⁰, I M Trigger^{159a}, S Trincaz-Duvold⁷⁸, M F Tripijana⁷⁰, N Triplett²⁵, W Trischuk¹⁵⁸, B Trocmé⁵⁵, C Troncon^{89a}, M Trotter-McDonald¹⁴², M Trovatelli^{134a,134b}, P True⁸⁸, M Trzebinski³⁹, A Trzupek³⁹, C Tsarouchas³⁰, J C-L Tseng¹¹⁸, M Tsiakiris¹⁰⁵,

P V Tsiareshka⁹⁰, D Tsionou¹³⁶, G Tsipolitis¹⁰, S Tsiskaridze¹², V Tsiskaridze⁴⁸, E G Tskhadadze^{51a}, I I Tsukerman⁹⁵, V Tsulaia¹⁵, J-W Tsung²¹, S Tsuno⁶⁵, D Tsybychev¹⁴⁸, A Tua¹³⁹, A Tudorache^{26a}, V Tudorache^{26a}, J M Tuggle³¹, M Turala³⁹, D Turecek¹²⁶, I Turk Cakir^{4d}, R Turra^{89a,89b}, P M Tuts³⁵, A Tykhonov⁷⁴, M Tylmad^{146a,146b}, M Tyndel¹²⁹, G Tzanakos⁹, K Uchida²¹, I Ueda¹⁵⁵, R Ueno²⁹, M Ughetto⁸³, M Ugland¹⁴, M Uhlenbrock²¹, F Ukegawa¹⁶⁰, G Unal³⁰, A Undrus²⁵, G Unel¹⁶³, F C Ungaro⁴⁸, Y Unno⁶⁵, D Urbaniec³⁵, P Urquijo²¹, G Usai⁸, L Vacavant⁸³, V Vacek¹²⁶, B Vachon⁸⁵, S Vahsen¹⁵, N Valencic¹⁰⁵, S Valentinetti^{20a,20b}, A Valero¹⁶⁷, L Valery³⁴, S Valkar¹²⁷, E Valladolid Gallego¹⁶⁷, S Vallecorsa¹⁵², J A Valls Ferrer¹⁶⁷, R Van Berg¹²⁰, P C Van Der Deijl¹⁰⁵, R van der Geer¹⁰⁵, H van der Graaf¹⁰⁵, R Van Der Leeuw¹⁰⁵, E van der Poel¹⁰⁵, D van der Ster³⁰, N van Eldik³⁰, P van Gemmeren⁶, J Van Nieuwkoop¹⁴², I van Vulpen¹⁰⁵, M Vanadia⁹⁹, W Vandelli³⁰, A Vaniachine⁶, P Vankov⁴², F Vannucci⁷⁸, R Vari^{132a}, E W Varnes⁷, T Varol⁸⁴, D Varouchas¹⁵, A Vartapetian⁸, K E Varvell¹⁵⁰, V I Vassilakopoulos⁵⁶, F Vazeille³⁴, T Vazquez Schroeder⁵⁴, F Veloso^{124a}, S Veneziano^{132a}, A Ventura^{72a,72b}, D Ventura⁸⁴, M Venturi⁴⁸, N Venturi¹⁵⁸, V Vercesi^{119a}, M Verducci¹³⁸, W Verkerke¹⁰⁵, J C Vermeulen¹⁰⁵, A Vest⁴⁴, M C Vetterli^{142,184}, I Vichou¹⁶⁵, T Vickey^{145b,213}, O E Vickey Boeriu^{145b}, G H A Viehhauser¹¹⁸, S Viel¹⁶⁸, M Villa^{20a,20b}, M Villaplana Perez¹⁶⁷, E Vilucchi⁴⁷, M G Vincter²⁹, E Vinek³⁰, V B Vinogradov⁶⁴, J Virzi¹⁵, O Vitells¹⁷², M Viti⁴², I Vivarelli⁴⁸, F Vives Vaque³, S Vlachos¹⁰, D Vladoiu⁹⁸, M Vlasak¹²⁶, A Vogel²¹, P Vokac¹²⁶, G Volpi⁴⁷, M Volpi⁸⁶, G Volpini^{89a}, H von der Schmitt⁹⁹, H von Radziewski⁴⁸, E von Toerne²¹, V Vorobel¹²⁷, V Vorwerk¹², M Vos¹⁶⁷, R Voss³⁰, J H Vossebeld⁷³, N Vranjes¹³⁶, M Vranjes Milosavljevic¹⁰⁵, V Vrba¹²⁵, M Vreeswijk¹⁰⁵, T Vu Anh⁴⁸, R Vuillermet³⁰, I Vukotic³¹, Z Vykydal¹²⁶, W Wagner¹⁷⁵, P Wagner²¹, H Wahlen¹⁷⁵, S Wahrmund⁴⁴, J Wakabayashi¹⁰¹, S Walch⁸⁷, J Walder⁷¹, R Walker⁹⁸, W Walkowiak¹⁴¹, R Wall¹⁷⁶, P Waller⁷³, B Walsh¹⁷⁶, C Wang⁴⁵, H Wang¹⁷³, H Wang⁴⁰, J Wang¹⁵¹, J Wang^{33a}, K Wang⁸⁵, R Wang¹⁰³, S M Wang¹⁵¹, T Wang²¹, X Wang¹⁷⁶, A Warburton⁸⁵, C P Ward²⁸, D R Wardrope⁷⁷, M Warsinsky⁴⁸, A Washbrook⁴⁶, C Wasicki⁴², I Watanabe⁶⁶, P M Watkins¹⁸, A T Watson¹⁸, I J Watson¹⁵⁰, M F Watson¹⁸, G Watts¹³⁸, S Watts⁸², A T Waugh¹⁵⁰, B M Waugh⁷⁷, M S Weber¹⁷, J S Webster³¹, A R Weidberg¹¹⁸, P Weigell⁹⁹, J Weingarten⁵⁴, C Weiser⁴⁸, P S Wells³⁰, T Wenaus²⁵, D Wendland¹⁶, Z Weng^{151,198}, T Wengler³⁰, S Wenig³⁰, N Wermes²¹, M Werner⁴⁸, P Werner³⁰, M Werth¹⁶³, M Wessels^{58a}, J Wetter¹⁶¹, C Weydert⁵⁵, K Whalen²⁹, A White⁸, M J White⁸⁶, S White^{122a,122b}, S R Whitehead¹¹⁸, D Whiteson¹⁶³, D Whittington⁶⁰, D Wicke¹⁷⁵, F J Wickens¹²⁹, W Wiedenmann¹⁷³, M Wielers¹²⁹, P Wienemann²¹, C Wiglesworth⁷⁵, L A M Wiik-Fuchs²¹, P A Wijeratne⁷⁷, A Wildauer⁹⁹, M A Wildt^{42,195}, I Wilhelm¹²⁷, H G Wilkens³⁰, J Z Will⁹⁸, E Williams³⁵, H H Williams¹²⁰, S Williams²⁸, W Willis^{35,216}, S Willocq⁸⁴, J A Wilson¹⁸, M G Wilson¹⁴³, A Wilson⁸⁷, I Wingerter-Seez⁵, S Winkelmann⁴⁸, F Winklmeier³⁰, M Wittgen¹⁴³, T Wittig⁴³, J Wittkowski⁹⁸, S J Wollstadt⁸¹, M W Wolter³⁹, H Wolters^{124a,187}, W C Wong⁴¹, G Wooden⁸⁷, B K Wosiek³⁹, J Wotschack³⁰, M J Woudstra⁸², K W Wozniak³⁹, K Wraight⁵³, M Wright⁵³, B Wrona⁷³, S L Wu¹⁷³, X Wu⁴⁹, Y Wu^{33b,214}, E Wulf³⁵, B M Wynne⁴⁶, S Xella³⁶, M Xiao¹³⁶, S Xie⁴⁸, C Xu^{33b,202}, D Xu^{33a}, L Xu^{33b}, B Yabsley¹⁵⁰, S Yacoob^{145a,215}, M Yamada⁶⁵, H Yamaguchi¹⁵⁵, A Yamamoto⁶⁵, K Yamamoto⁶³, S Yamamoto¹⁵⁵, T Yamamura¹⁵⁵, T Yamanaka¹⁵⁵, K Yamauchi¹⁰¹, T Yamazaki¹⁵⁵, Y Yamazaki⁶⁶, Z Yan²², H Yang^{33e}, H Yang¹⁷³, U K Yang⁸², Y Yang¹⁰⁹, Z Yang^{146a,146b}, S Yanush⁹¹, L Yao^{33a}, Y Yasu⁶⁵, E Yatsenko⁴², J Ye⁴⁰, S Ye²⁵, A L Yen⁵⁷, M Yilmaz^{4b}, R Yoosoofmiya¹²³, K Yorita¹⁷¹, R Yoshida⁶, K Yoshihara¹⁵⁵, C Young¹⁴³, C J Young¹¹⁸, S Youssef²², D Yu²⁵, D R Yu¹⁵, J Yu⁸, J Yu¹¹², L Yuan⁶⁶, A Yurkewicz¹⁰⁶, B Zabinski³⁹, R Zaidan⁶², A M Zaitsev¹²⁸, L Zanello^{132a,132b}

D Zanzi⁹⁹, A Zaytsev²⁵, C Zeitnitz¹⁷⁵, M Zeman¹²⁶, A Zemla³⁹, O Zenin¹²⁸, T Ženiš^{144a}, D Zerwas¹¹⁵, G Zevi della Porta⁵⁷, D Zhang⁸⁷, H Zhang⁸⁸, J Zhang⁶, L Zhang¹⁵¹, X Zhang^{33d}, Z Zhang¹¹⁵, L Zhao¹⁰⁸, Z Zhao^{33b}, A Zhemchugov⁶⁴, J Zhong¹¹⁸, B Zhou⁸⁷, N Zhou¹⁶³, Y Zhou¹⁵¹, C G Zhu^{33d}, H Zhu⁴², J Zhu⁸⁷, Y Zhu^{33b}, X Zhuang^{33a}, V Zhuravlov⁹⁹, A Zibell⁹⁸, D Zieminska⁶⁰, N I Zimin⁶⁴, R Zimmermann²¹, S Zimmermann²¹, S Zimmermann⁴⁸, Z Zinonos^{122a,122b}, M Ziolkowski¹⁴¹, R Zitoun⁵, L Živković³⁵, V V Zmouchko^{128,216}, G Zobernig¹⁷³, A Zoccoli^{20a,20b}, M zur Nedden¹⁶, V Zutshi¹⁰⁶ and L Zwalinski³⁰

¹ School of Chemistry and Physics, University of Adelaide, Adelaide, Australia

² Physics Department, SUNY Albany, Albany, NY, USA

³ Department of Physics, University of Alberta, Edmonton, AB, Canada

^{4a} Department of Physics, Ankara University, Ankara, Turkey

^{4b} Department of Physics, Gazi University, Ankara, Turkey

^{4c} Division of Physics, TOBB University of Economics and Technology, Ankara, Turkey

^{4d} Turkish Atomic Energy Authority, Ankara, Turkey

⁵ LAPP, CNRS/IN2P3 and Université de Savoie, Annecy-le-Vieux, France

⁶ High Energy Physics Division, Argonne National Laboratory, Argonne, IL, USA

⁷ Department of Physics, University of Arizona, Tucson, AZ, USA

⁸ Department of Physics, The University of Texas at Arlington, Arlington, TX, USA

⁹ Physics Department, University of Athens, Athens, Greece

¹⁰ Physics Department, National Technical University of Athens, Zografou, Greece

¹¹ Institute of Physics, Azerbaijan Academy of Sciences, Baku, Azerbaijan

¹² Institut de Física d'Altes Energies and Departament de Física de la Universitat Autònoma de Barcelona and ICREA, Barcelona, Spain

^{13a} Institute of Physics, University of Belgrade, Belgrade, Serbia

^{13b} Vinca Institute of Nuclear Sciences, University of Belgrade, Belgrade, Serbia

¹⁴ Department for Physics and Technology, University of Bergen, Bergen, Norway

¹⁵ Physics Division, Lawrence Berkeley National Laboratory and University of California, Berkeley, CA, USA

¹⁶ Department of Physics, Humboldt University, Berlin, Germany

¹⁷ Albert Einstein Center for Fundamental Physics and Laboratory for High Energy Physics, University of Bern, Bern, Switzerland

¹⁸ School of Physics and Astronomy, University of Birmingham, Birmingham, UK

^{19a} Department of Physics, Bogazici University, Istanbul, Turkey

^{19b} Division of Physics, Dogus University, Istanbul, Turkey

^{19c} Department of Physics Engineering, Gaziantep University, Gaziantep, Turkey

^{20a} INFN Sezione di Bologna, Bologna, Italy

^{20b} Dipartimento di Fisica, Università di Bologna, Bologna, Italy

²¹ Physikalisches Institut, University of Bonn, Bonn, Germany

²² Department of Physics, Boston University, Boston, MA, USA

²³ Department of Physics, Brandeis University, Waltham, MA, USA

^{24a} Universidade Federal do Rio De Janeiro COPPE/EE/IF, Rio de Janeiro, Brazil

^{24b} Federal University of Juiz de Fora (UFJF), Juiz de Fora, Brazil

^{24c} Federal University of Sao Joao del Rei (UFSJ), Sao Joao del Rei, Brazil

^{24d} Instituto de Fisica, Universidade de Sao Paulo, Sao Paulo, Brazil

²⁵ Physics Department, Brookhaven National Laboratory, Upton, NY, USA

- ^{26a} National Institute of Physics and Nuclear Engineering, Bucharest, Romania
^{26b} University Politehnica Bucharest, Bucharest, Romania
^{26c} West University in Timisoara, Timisoara, Romania
²⁷ Departamento de Física, Universidad de Buenos Aires, Buenos Aires, Argentina
²⁸ Cavendish Laboratory, University of Cambridge, Cambridge, UK
²⁹ Department of Physics, Carleton University, Ottawa, ON, Canada
³⁰ CERN, Geneva, Switzerland
³¹ Enrico Fermi Institute, University of Chicago, Chicago, IL, USA
^{32a} Departamento de Física, Pontificia Universidad Católica de Chile, Santiago, Chile
^{32b} Departamento de Física, Universidad Técnica Federico Santa María, Valparaíso, Chile
^{33a} Institute of High Energy Physics, Chinese Academy of Sciences, Beijing, China
^{33b} Department of Modern Physics, University of Science and Technology of China, Anhui, China
^{33c} Department of Physics, Nanjing University, Jiangsu, China
^{33d} School of Physics, Shandong University, Shandong, China
^{33e} Physics Department, Shanghai Jiao Tong University, Shanghai, China
³⁴ Laboratoire de Physique Corpusculaire, Clermont Université and Université Blaise Pascal and CNRS/IN2P3, Clermont-Ferrand, France
³⁵ Nevis Laboratory, Columbia University, Irvington, NY, USA
³⁶ Niels Bohr Institute, University of Copenhagen, Copenhagen, Denmark
^{37a} INFN Gruppo Collegato di Cosenza, Italy
^{37b} Dipartimento di Fisica, Università della Calabria, Rende, Italy
³⁸ AGH University of Science and Technology, Faculty of Physics and Applied Computer Science, Krakow, Poland
³⁹ The Henryk Niewodniczanski Institute of Nuclear Physics, Polish Academy of Sciences, Krakow, Poland
⁴⁰ Physics Department, Southern Methodist University, Dallas, TX, USA
⁴¹ Physics Department, University of Texas at Dallas, Richardson, TX, USA
⁴² DESY, Hamburg and Zeuthen, Germany
⁴³ Institut für Experimentelle Physik IV, Technische Universität Dortmund, Dortmund, Germany
⁴⁴ Institut für Kern- und Teilchenphysik, Technical University Dresden, Dresden, Germany
⁴⁵ Department of Physics, Duke University, Durham, NC, USA
⁴⁶ SUPA—School of Physics and Astronomy, University of Edinburgh, Edinburgh, UK
⁴⁷ INFN Laboratori Nazionali di Frascati, Frascati, Italy
⁴⁸ Fakultät für Mathematik und Physik, Albert-Ludwigs-Universität, Freiburg, Germany
⁴⁹ Section de Physique, Université de Genève, Geneva, Switzerland
^{50a} INFN Sezione di Genova, Genova, Italy
^{50b} Dipartimento di Fisica, Università di Genova, Genova, Italy
^{51a} Ekvter Andronikashvili Institute of Physics, Ivane Javakhishvili Tbilisi State University, Tbilisi, Georgia
^{51b} High Energy Physics Institute, Tbilisi State University, Tbilisi, Georgia
⁵² II Physikalisches Institut, Justus-Liebig-Universität Giessen, Giessen, Germany
⁵³ SUPA—School of Physics and Astronomy, University of Glasgow, Glasgow, UK
⁵⁴ II Physikalisches Institut, Georg-August-Universität, Göttingen, Germany
⁵⁵ Laboratoire de Physique Subatomique et de Cosmologie, Université Joseph Fourier and CNRS/IN2P3 and Institut National Polytechnique de Grenoble, Grenoble, France

- ⁵⁶ Department of Physics, Hampton University, Hampton, VA, USA
- ⁵⁷ Laboratory for Particle Physics and Cosmology, Harvard University, Cambridge, MA, USA
- ^{58a} Kirchhoff-Institut für Physik, Ruprecht-Karls-Universität Heidelberg, Heidelberg, Germany
- ^{58b} Physikalisches Institut, Ruprecht-Karls-Universität Heidelberg, Heidelberg, Germany
- ^{58c} ZITI Institut für technische Informatik, Ruprecht-Karls-Universität Heidelberg, Mannheim, Germany
- ⁵⁹ Faculty of Applied Information Science, Hiroshima Institute of Technology, Hiroshima, Japan
- ⁶⁰ Department of Physics, Indiana University, Bloomington, IN, USA
- ⁶¹ Institut für Astro- und Teilchenphysik, Leopold-Franzens-Universität, Innsbruck, Austria
- ⁶² University of Iowa, Iowa City, IA, USA
- ⁶³ Department of Physics and Astronomy, Iowa State University, Ames, IA, USA
- ⁶⁴ Joint Institute for Nuclear Research, JINR Dubna, Dubna, Russia
- ⁶⁵ KEK, High Energy Accelerator Research Organization, Tsukuba, Japan
- ⁶⁶ Graduate School of Science, Kobe University, Kobe, Japan
- ⁶⁷ Faculty of Science, Kyoto University, Kyoto, Japan
- ⁶⁸ Kyoto University of Education, Kyoto, Japan
- ⁶⁹ Department of Physics, Kyushu University, Fukuoka, Japan
- ⁷⁰ Instituto de Física La Plata, Universidad Nacional de La Plata and CONICET, La Plata, Argentina
- ⁷¹ Physics Department, Lancaster University, Lancaster, UK
- ^{72a} INFN Sezione di Lecce, Lecce, Italy
- ^{72b} Dipartimento di Matematica e Fisica, Università del Salento, Lecce, Italy
- ⁷³ Oliver Lodge Laboratory, University of Liverpool, Liverpool, UK
- ⁷⁴ Department of Physics, Jožef Stefan Institute and University of Ljubljana, Ljubljana, Slovenia
- ⁷⁵ School of Physics and Astronomy, Queen Mary University of London, London, UK
- ⁷⁶ Department of Physics, Royal Holloway University of London, Surrey, UK
- ⁷⁷ Department of Physics and Astronomy, University College London, London, UK
- ⁷⁸ Laboratoire de Physique Nucléaire et de Hautes Energies, UPMC and Université Paris-Diderot and CNRS/IN2P3, Paris, France
- ⁷⁹ Fysiska institutionen, Lunds universitet, Lund, Sweden
- ⁸⁰ Departamento de Física Teórica C-15, Universidad Autónoma de Madrid, Madrid, Spain
- ⁸¹ Institut für Physik, Universität Mainz, Mainz, Germany
- ⁸² School of Physics and Astronomy, University of Manchester, Manchester, UK
- ⁸³ CPPM, Aix-Marseille Université and CNRS/IN2P3, Marseille, France
- ⁸⁴ Department of Physics, University of Massachusetts, Amherst, MA, USA
- ⁸⁵ Department of Physics, McGill University, Montreal, QC, Canada
- ⁸⁶ School of Physics, University of Melbourne, Victoria, Australia
- ⁸⁷ Department of Physics, The University of Michigan, Ann Arbor, MI, USA
- ⁸⁸ Department of Physics and Astronomy, Michigan State University, East Lansing, MI, USA
- ^{89a} INFN Sezione di Milano, Milano, Italy
- ^{89b} Dipartimento di Fisica, Università di Milano, Milano, Italy
- ⁹⁰ B I Stepanov Institute of Physics, National Academy of Sciences of Belarus, Minsk, Republic of Belarus
- ⁹¹ National Scientific and Educational Centre for Particle and High Energy Physics, Minsk, Republic of Belarus
- ⁹² Department of Physics, Massachusetts Institute of Technology, Cambridge, MA, USA

- ⁹³ Group of Particle Physics, University of Montreal, Montreal, QC, Canada
- ⁹⁴ P N Lebedev Institute of Physics, Academy of Sciences, Moscow, Russia
- ⁹⁵ Institute for Theoretical and Experimental Physics (ITEP), Moscow, Russia
- ⁹⁶ Moscow Engineering and Physics Institute (MEPhI), Moscow, Russia
- ⁹⁷ D V Skobeltsyn Institute of Nuclear Physics, M V Lomonosov Moscow State University, Moscow, Russia
- ⁹⁸ Fakultät für Physik, Ludwig-Maximilians-Universität München, München, Germany
- ⁹⁹ Max-Planck-Institut für Physik (Werner-Heisenberg-Institut), München, Germany
- ¹⁰⁰ Nagasaki Institute of Applied Science, Nagasaki, Japan
- ¹⁰¹ Graduate School of Science and Kobayashi-Maskawa Institute, Nagoya University, Nagoya, Japan
- ^{102a} INFN Sezione di Napoli, Napoli, Italy
- ^{102b} Dipartimento di Scienze Fisiche, Università di Napoli, Napoli, Italy
- ¹⁰³ Department of Physics and Astronomy, University of New Mexico, Albuquerque, NM, USA
- ¹⁰⁴ Institute for Mathematics, Astrophysics and Particle Physics, Radboud University Nijmegen/Nikhef, Nijmegen, Netherlands
- ¹⁰⁵ Nikhef National Institute for Subatomic Physics and University of Amsterdam, Amsterdam, Netherlands
- ¹⁰⁶ Department of Physics, Northern Illinois University, DeKalb, IL, USA
- ¹⁰⁷ Budker Institute of Nuclear Physics, SB RAS, Novosibirsk, Russia
- ¹⁰⁸ Department of Physics, New York University, New York, NY, USA
- ¹⁰⁹ Ohio State University, Columbus, OH, USA
- ¹¹⁰ Faculty of Science, Okayama University, Okayama, Japan
- ¹¹¹ Homer L. Dodge Department of Physics and Astronomy, University of Oklahoma, Norman, OK, USA
- ¹¹² Department of Physics, Oklahoma State University, Stillwater, OK, USA
- ¹¹³ Palacký University, RCPTM, Olomouc, Czech Republic
- ¹¹⁴ Center for High Energy Physics, University of Oregon, Eugene, OR, USA
- ¹¹⁵ LAL, Université Paris-Sud and CNRS/IN2P3, Orsay, France
- ¹¹⁶ Graduate School of Science, Osaka University, Osaka, Japan
- ¹¹⁷ Department of Physics, University of Oslo, Oslo, Norway
- ¹¹⁸ Department of Physics, Oxford University, Oxford, UK
- ^{119a} INFN Sezione di Pavia, Pavia, Italy
- ^{119b} Dipartimento di Fisica, Università di Pavia, Pavia, Italy
- ¹²⁰ Department of Physics, University of Pennsylvania, Philadelphia, PA, USA
- ¹²¹ Petersburg Nuclear Physics Institute, Gatchina, Russia
- ^{122a} INFN Sezione di Pisa, Pisa, Italy
- ^{122b} Dipartimento di Fisica Enrico Fermi, Università di Pisa, Pisa, Italy
- ¹²³ Department of Physics and Astronomy, University of Pittsburgh, Pittsburgh, PA, USA
- ^{124a} Laboratório de Instrumentação e Física Experimental de Partículas—LIP, Lisboa, Portugal
- ^{124b} Departamento de Física Teórica y del Cosmos and CAFPE, Universidad de Granada, Granada, Spain
- ¹²⁵ Institute of Physics, Academy of Sciences of the Czech Republic, Praha, Czech Republic
- ¹²⁶ Czech Technical University in Prague, Praha, Czech Republic
- ¹²⁷ Faculty of Mathematics and Physics, Charles University in Prague, Praha, Czech Republic
- ¹²⁸ State Research Center Institute for High Energy Physics, Protvino, Russia

- ¹²⁹ Particle Physics Department, Rutherford Appleton Laboratory, Didcot, UK
- ¹³⁰ Physics Department, University of Regina, Regina, SK, Canada
- ¹³¹ Ritsumeikan University, Kusatsu, Shiga, Japan
- ^{132a} INFN Sezione di Roma I, Rome, Italy
- ^{132b} Dipartimento di Fisica, Università La Sapienza, Roma, Italy
- ^{133a} INFN Sezione di Roma Tor Vergata, Rome, Italy
- ^{133b} Dipartimento di Fisica, Università di Roma Tor Vergata, Roma, Italy
- ^{134a} INFN Sezione di Roma Tre, Roma, Italy
- ^{134b} Dipartimento di Fisica, Università Roma Tre, Roma, Italy
- ^{135a} Faculté des Sciences Ain Chock, Réseau Universitaire de Physique des Hautes Energies, Université Hassan II, Casablanca, Morocco
- ^{135b} Centre National de l'Énergie des Sciences Techniques Nucleaires, Rabat, Morocco
- ^{135c} Faculté des Sciences Semlalia, Université Cadi Ayyad, LPHEA-Marrakech, Morocco
- ^{135d} Faculté des Sciences, Université Mohamed Premier and LPTPM, Oujda, Morocco
- ^{135e} Faculté des sciences, Université Mohammed V-Agdal, Rabat, Morocco
- ¹³⁶ DSM/IRFU (Institut de Recherches sur les Lois Fondamentales de l'Univers), CEA Saclay (Commissariat à l'Énergie Atomique et aux Énergies Alternatives), Gif-sur-Yvette, France
- ¹³⁷ Santa Cruz Institute for Particle Physics, University of California Santa Cruz, Santa Cruz, CA, USA
- ¹³⁸ Department of Physics, University of Washington, Seattle, WA, USA
- ¹³⁹ Department of Physics and Astronomy, University of Sheffield, Sheffield, UK
- ¹⁴⁰ Department of Physics, Shinshu University, Nagano, Japan
- ¹⁴¹ Fachbereich Physik, Universität Siegen, Siegen, Germany
- ¹⁴² Department of Physics, Simon Fraser University, Burnaby, BC, Canada
- ¹⁴³ SLAC National Accelerator Laboratory, Stanford, CA, USA
- ^{144a} Faculty of Mathematics, Physics & Informatics, Comenius University, Bratislava, Slovak Republic
- ^{144b} Department of Subnuclear Physics, Institute of Experimental Physics of the Slovak Academy of Sciences, Kosice, Slovak Republic
- ^{145a} Department of Physics, University of Johannesburg, Johannesburg, South Africa
- ^{145b} School of Physics, University of the Witwatersrand, Johannesburg, South Africa
- ^{146a} Department of Physics, Stockholm University, Stockholm, Sweden
- ^{146b} The Oskar Klein Centre, Stockholm, Sweden
- ¹⁴⁷ Physics Department, Royal Institute of Technology, Stockholm, Sweden
- ¹⁴⁸ Departments of Physics & Astronomy and Chemistry, Stony Brook University, Stony Brook, NY, USA
- ¹⁴⁹ Department of Physics and Astronomy, University of Sussex, Brighton, UK
- ¹⁵⁰ School of Physics, University of Sydney, Sydney, Australia
- ¹⁵¹ Institute of Physics, Academia Sinica, Taipei, Taiwan
- ¹⁵² Department of Physics, Technion: Israel Institute of Technology, Haifa, Israel
- ¹⁵³ Raymond and Beverly Sackler School of Physics and Astronomy, Tel Aviv University, Tel Aviv, Israel
- ¹⁵⁴ Department of Physics, Aristotle University of Thessaloniki, Thessaloniki, Greece
- ¹⁵⁵ International Center for Elementary Particle Physics and Department of Physics, The University of Tokyo, Tokyo, Japan
- ¹⁵⁶ Graduate School of Science and Technology, Tokyo Metropolitan University, Tokyo, Japan

- ¹⁵⁷ Department of Physics, Tokyo Institute of Technology, Tokyo, Japan
- ¹⁵⁸ Department of Physics, University of Toronto, Toronto, ON, Canada
- ^{159a} TRIUMF, Vancouver, BC, Canada
- ^{159b} Department of Physics and Astronomy, York University, Toronto, ON, Canada
- ¹⁶⁰ Faculty of Pure and Applied Sciences, University of Tsukuba, Tsukuba, Japan
- ¹⁶¹ Department of Physics and Astronomy, Tufts University, Medford, MA, USA
- ¹⁶² Centro de Investigaciones, Universidad Antonio Narino, Bogota, Colombia
- ¹⁶³ Department of Physics and Astronomy, University of California Irvine, Irvine, CA, USA
- ^{164a} INFN Gruppo Collegato di Udine, Italy
- ^{164b} ICTP, Trieste, Italy
- ^{164c} Dipartimento di Chimica, Fisica e Ambiente, Università di Udine, Udine, Italy
- ¹⁶⁵ Department of Physics, University of Illinois, Urbana, IL, USA
- ¹⁶⁶ Department of Physics and Astronomy, University of Uppsala, Uppsala, Sweden
- ¹⁶⁷ Instituto de Física Corpuscular (IFIC) and Departamento de Física Atómica, Molecular y Nuclear and Departamento de Ingeniería Electrónica and Instituto de Microelectrónica de Barcelona (IMB-CNM), University of Valencia and CSIC, Valencia, Spain
- ¹⁶⁸ Department of Physics, University of British Columbia, Vancouver, BC, Canada
- ¹⁶⁹ Department of Physics and Astronomy, University of Victoria, Victoria, BC, Canada
- ¹⁷⁰ Department of Physics, University of Warwick, Coventry, UK
- ¹⁷¹ Waseda University, Tokyo, Japan
- ¹⁷² Department of Particle Physics, The Weizmann Institute of Science, Rehovot, Israel
- ¹⁷³ Department of Physics, University of Wisconsin, Madison, WI, USA
- ¹⁷⁴ Fakultät für Physik und Astronomie, Julius-Maximilians-Universität, Würzburg, Germany
- ¹⁷⁵ Fachbereich C Physik, Bergische Universität Wuppertal, Wuppertal, Germany
- ¹⁷⁶ Department of Physics, Yale University, New Haven, CT, USA
- ¹⁷⁷ Yerevan Physics Institute, Yerevan, Armenia
- ¹⁷⁸ Centre de Calcul de l'Institut National de Physique Nucléaire et de Physique des Particules (IN2P3), Villeurbanne, France
- ¹⁷⁹ Also at Department of Physics, King's College London, London, UK
- ¹⁸⁰ Also at Laboratório de Instrumentação e Física Experimental de Partículas—LIP, Lisboa, Portugal
- ¹⁸¹ Also at Faculdade de Ciências and CFNUL, Universidade de Lisboa, Lisboa, Portugal
- ¹⁸² Also at Particle Physics Department, Rutherford Appleton Laboratory, Didcot, UK
- ¹⁸³ Also at Department of Physics, University of Johannesburg, Johannesburg, South Africa
- ¹⁸⁴ Also at TRIUMF, Vancouver, BC, Canada
- ¹⁸⁵ Also at Department of Physics, California State University, Fresno, CA, USA
- ¹⁸⁶ Also at Novosibirsk State University, Novosibirsk, Russia
- ¹⁸⁷ Also at Department of Physics, University of Coimbra, Coimbra, Portugal
- ¹⁸⁸ Also at Università di Napoli Parthenope, Napoli, Italy
- ¹⁸⁹ Also at Institute of Particle Physics (IPP), Canada
- ¹⁹⁰ Also at Department of Physics, Middle East Technical University, Ankara, Turkey
- ¹⁹¹ Also at Louisiana Tech University, Ruston, LA, USA
- ¹⁹² Also at Departamento de Física and CEFITEC of Faculdade de Ciências e Tecnologia, Universidade Nova de Lisboa, Caparica, Portugal
- ¹⁹³ Also at Department of Physics, University of Cape Town, Cape Town, South Africa
- ¹⁹⁴ Also at Institute of Physics, Azerbaijan Academy of Sciences, Baku, Azerbaijan

- ¹⁹⁵ Also at Institut für Experimentalphysik, Universität Hamburg, Hamburg, Germany
- ¹⁹⁶ Also at Manhattan College, New York, NY, USA
- ¹⁹⁷ Also at CPPM, Aix-Marseille Université and CNRS/IN2P3, Marseille, France
- ¹⁹⁸ Also at School of Physics and Engineering, Sun Yat-sen University, Guanzhou, China
- ¹⁹⁹ Also at Academia Sinica Grid Computing, Institute of Physics, Academia Sinica, Taipei, Taiwan
- ²⁰⁰ Also at School of Physics, Shandong University, Shandong, China
- ²⁰¹ Also at Dipartimento di Fisica, Università La Sapienza, Roma, Italy
- ²⁰² Also at DSM/IRFU (Institut de Recherches sur les Lois Fondamentales de l'Univers), CEA Saclay (Commissariat à l'Energie Atomique et aux Energies Alternatives), Gif-sur-Yvette, France
- ²⁰³ Also at Section de Physique, Université de Genève, Geneva, Switzerland
- ²⁰⁴ Also at Departamento de Física, Universidade de Minho, Braga, Portugal
- ²⁰⁵ Also at Department of Physics, The University of Texas at Austin, Austin, TX, USA
- ²⁰⁶ Also at Department of Physics and Astronomy, University of South Carolina, Columbia, SC, USA
- ²⁰⁷ Also at Institute for Particle and Nuclear Physics, Wigner Research Centre for Physics, Budapest, Hungary
- ²⁰⁸ Also at International School for Advanced Studies (SISSA), Trieste, Italy
- ²⁰⁹ Also at Institute of Physics, Jagiellonian University, Krakow, Poland
- ²¹⁰ Also at LAL, Université Paris-Sud and CNRS/IN2P3, Orsay, France
- ²¹¹ Also at Faculty of Physics, M.V. Lomonosov Moscow State University, Moscow, Russia
- ²¹² Also at Nevis Laboratory, Columbia University, Irvington, NY, USA
- ²¹³ Also at Department of Physics, Oxford University, Oxford, UK
- ²¹⁴ Also at Department of Physics, The University of Michigan, Ann Arbor, MI, USA
- ²¹⁵ Also at Discipline of Physics, University of KwaZulu-Natal, Durban, South Africa
- ²¹⁶ Deceased

References

- [1] ATLAS Collaboration 2012 Observation of a new particle in the search for the standard model Higgs boson with the ATLAS detector at the LHC *Phys. Lett. B* **716** 1–29
- [2] CMS Collaboration 2012 Observation of a new boson at a mass of 125 GeV with the CMS experiment at the LHC *Phys. Lett. B* **716** 30–61
- [3] Higgs P W 1964 Broken symmetries, massless particles and gauge fields *Phys. Lett.* **12** 132–3
- [4] Englert F and Brout R 1964 Broken symmetry and the mass of gauge vector mesons *Phys. Rev. Lett.* **13** 321–3
- [5] Guralnik G S, Hagen C R and Kibble T W B 1964 Global conservation laws and massless particles *Phys. Rev. Lett.* **13** 585–7
- [6] Falkowski A, Ruderman J T, Volansky T and Zupan J 2010 Hidden Higgs decaying to lepton jets *J. High Energy Phys.* **JHEP05(2010)077**
- [7] Falkowski A, Ruderman J T, Volansky T and Zupan J 2010 Discovering Higgs boson decays to lepton jets at hadron colliders *Phys. Rev. Lett.* **105** 241801
- [8] Strassler M J and Zurek K M 2007 Echoes of a hidden valley at hadron colliders *Phys. Lett. B* **651** 374–9
- [9] Arkani-Hamed N, Finkbeiner D P, Slatyer T R and Weiner N 2009 A theory of dark matter *Phys. Rev. D* **79** 015014
- [10] Arkani-Hamed N and Weiner N 2008 LHC Signals for a super unified theory of dark matter *J. High Energy Phys.* **JHEP12(2008)104**

- [11] Baumgart M, Cheung C, Ruderman J T, Wang L-T and Yavin I 2009 Non-abelian dark sectors and their collider signatures *J. High Energy Phys.* **JHEP04(2009)014**
- [12] Patt B and Wilczek F 2006 Higgs-field portal into hidden sectors arXiv:hep-ph/0605188
- [13] Davoudiasl H, Kitano R, Tianjun Li and Murayama H 2005 The new minimal standard model *Phys. Lett. B* **609** 117–23
- [14] Gross D J, Harvey J A, Martinec E and Rohm R 1985 Heterotic string theory (I). The free heterotic string *Nucl. Phys. B* **256** 253–84
- [15] Georgi H 2007 Unparticle physics *Phys. Rev. Lett.* **98** 221601
- [16] Holdom B 1986 Searching for epsilon charges and a new $U(1)$ *Phys. Lett. B* **178** 65–70
- [17] Dienes K R, Kolda C F and March-Russell J 1997 Kinetic mixing and the supersymmetric gauge hierarchy *Nucl. Phys. B* **492** 104–18
- [18] Barwick S W *et al* (HEAT Collaboration) 1997 Measurements of the cosmic-ray positron fraction from 1 to 50 GeV *Astrophys. J. Lett.* **482** L191
- [19] Abdo A A *et al* (Fermi LAT Collaboration) 2009 Measurement of the cosmic ray $e^+ + e^-$ spectrum from 20 GeV to 1 TeV with the Fermi large area telescope *Phys. Rev. Lett.* **102** 181101
- [20] Adriani O *et al* (PAMELA Collaboration) 2009 An anomalous positron abundance in cosmic rays with energies 1.5–100 GeV *Nature* **458** 607–9
- [21] Chang J *et al* 2008 An excess of cosmic ray electrons at energies of 300–800 GeV *Nature* **456** 362–5
- [22] Aaltonen T *et al* (CDF Collaboration) 2012 Search for anomalous production of multiple leptons in association with W and Z bosons at CDF *Phys. Rev. D* **85** 092001
- [23] ATLAS Collaboration 2013 A search for prompt lepton-jets in pp collisions at $\sqrt{s} = 7$ TeV with the ATLAS detector *Phys. Lett. B* **719** 299–317
- [24] CMS Collaboration 2011 Search for light resonances decaying into pairs of muons as a signal of new physics *J. High Energy Phys.* **JHEP07(2011)098**
- [25] Abazov V M *et al* (D0 Collaboration) 2010 Search for events with leptonic jets and missing transverse energy in $p\bar{p}$ collisions at $\sqrt{s} = 1.96$ TeV *Phys. Rev. Lett.* **105** 211802
- [26] ATLAS Collaboration 2013 Search for displaced muonic lepton jets from light Higgs boson decay in proton-proton collisions at $\sqrt{s} = 7$ TeV with the ATLAS detector *Phys. Lett. B* **721** 32–50
- [27] ATLAS Collaboration 2008 The ATLAS experiment at the CERN Large Hadron Collider *J. Instrum.* **3** S08003
- [28] ATLAS Collaboration 2012 Performance of the ATLAS Trigger System in 2010 *Eur. Phys. J. C* **72** 1849
- [29] Alwall J *et al* 2007 MadGraph/MadEvent v4: the new web generation *J. High Energy Phys.* **JHEP09(2007)028**
- [30] Meade P and Reece M 2007 BRIDGE: branching ratio inquiry/decay generated events arXiv:hep-ph/0703031
- [31] Sjostrand T, Mrenna S and Skands P Z 2006 PYTHIA 6.4 physics and manual *J. High Energy Phys.* **JHEP05(2006)026**
- [32] Mangano M L, Moretti M, Piccinini F, Pittau R and Polosa A D 2003 ALPGEN, a generator for hard multiparton processes in hadronic collisions *J. High Energy Phys.* **JHEP07(2003)001**
- [33] Alwall J *et al* 2008 Comparative study of various algorithms for the merging of parton showers and matrix elements in hadronic collisions *Eur. Phys. J. C* **53** 473–500
- [34] Corcella G *et al* 2001 HERWIG 6.5: an event generator for hadron emission reactions with interfering gluons (including supersymmetric processes) *J. High Energy Phys.* **JHEP01(2001)010**
- [35] Butterworth J M *et al* 1996 Multiparton interactions in photoproduction at HERA *Z. Phys. C* **72** 637–46
- [36] Frixione S and Webber B R 2002 Matching NLO QCD computations and parton shower simulations *J. High Energy Phys.* **JHEP06(2002)029**
- [37] Gleisberg T *et al* 2009 Event generation with SHERPA 1.1 *J. High Energy Phys.* **JHEP02(2009)007**
- [38] Sjostrand T and van Zijl M 1987 A multiple-interaction model for the event structure in hadron collisions *Phys. Rev. D* **36** 2019–41
- [39] Frixione S, Nason P and Oleari C 2007 Matching NLO QCD computations with Parton Shower simulations: the POWHEG method *J. High Energy Phys.* **JHEP11(2007)070**

- [40] Davidson N, Nanava G, Przedzinski T, Richter-Was E and Was Z 2010 Universal interface of TAUOLA technical and physics documentation arXiv:1002.0543 [hep-ph]
- [41] ATLAS Collaboration 2012 Measurement of the inclusive W^\pm and Z/γ cross sections in the electron and muon decay channels in pp collisions at $\sqrt{s} = 7$ TeV with the ATLAS detector *Phys. Rev. D* **85** 072004
- [42] ATLAS Collaboration 2012 Measurement of the top quark pair production cross-section with ATLAS in the single lepton channel *Phys. Lett. B* **711** 244–63
- [43] Melnikov K and Petriello F 2006 Electroweak gauge boson production at hadron colliders through $O(\alpha_s^2)$ *Phys. Rev. D* **74** 114017
- [44] Allison J *et al* 2006 Geant4 developments and applications *IEEE Trans. Nucl. Sci.* **53** 270
- [45] ATLAS Collaboration 2010 The ATLAS simulation infrastructure *Eur. Phys. J. C* **70** 823–74
- [46] ATLAS Collaboration 2012 Electron performance measurements with the ATLAS detector using the 2010 LHC proton–proton collision data *Eur. Phys. J. C* **72** 1909
- [47] ATLAS Collaboration 2011 Muon momentum resolution in first pass reconstruction of pp collision data recorded by ATLAS in 2010 (cds.cern.ch/record/1338575/files/ATLAS-CONF-2011-046.pdf)
- [48] ATLAS Collaboration 2011 Luminosity determination in pp collisions at $\sqrt{s} = 7$ TeV using the ATLAS detector at the LHC *Eur. Phys. J. C* **71** 1630
- [49] ATLAS Collaboration 2011 Luminosity determination in pp collisions at $\sqrt{s} = 7$ TeV using the ATLAS detector in 2011 (cds.cern.ch/record/1376384/files/ATLAS-CONF-2011-116.pdf)
- [50] Cacciari M, Salam G P and Soyez G 2008 The anti- k_t jet clustering algorithm *J. High Energy Phys.* **JHEP04(2008)063**
- [51] ATLAS Collaboration 2011 Performance of particle identification with the transition ATLAS radiation tracker arXiv:1109.5925 [physics.ins-det]
- [52] ATLAS Collaboration 2011 Measurement of the top quark-pair production cross section with ATLAS in pp collisions at $\sqrt{s} = 7$ TeV *Eur. Phys. J. C* **71** 1577
- [53] Dittmaier S, Mariotti C, Passarino G and Tanaka R (ed) (LHC Higgs Cross Section Working Group) 2012 Handbook of LHC Higgs cross sections: 2. Differential distributions CERN-2012-002, CERN, Geneva (arXiv:1201.3084 [hep-ph])
- [54] Read A L 2002 Presentation of search results: the CL(s) technique *J. Phys. G: Nucl. Part. Phys.* **28** 2693–704
- [55] Cranmer K, Lewis G, Moneta L, Shibata A and Verkerke W 2012 Histfactory: a tool for creating statistical models for use with RooFit and RooStats *Technical Report CERN-OPEN-2012-016* (New York: New York University)