

Axiomatic Design of a Manually Powered Wheelchair Lift Mechanism

by

Kevin DiGenova and Chris Coleman

Massachusetts Institute of Technology

Submitted to the Department of Mechanical Engineering
in Partial Fulfillment of the Requirements for the Degree of
Bachelor of Science in Mechanical Engineering

at the

Massachusetts Institute of Technology

May 2007

[June 2007]

© 2007 Massachusetts Institute of Technology
All rights reserved.

Signature of Author.....
Department of Mechanical Engineering
May, 2007

Signature of Author.....
Department of Mechanical Engineering
May, 2007

Certified by.....
Sang-Gook Kim
Associate Professor of Mechanical Engineering
Thesis Supervisor

Accepted by.....
John Lienhard
Professor of Mechanical Engineering
Undergraduate Officer

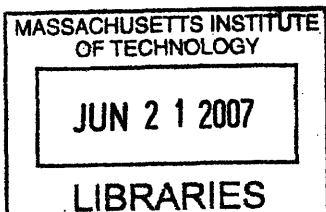

ARCHIVES

Axiomatic Design of a Manually Powered Wheelchair Lift Mechanism

by

Kevin DiGenova and Christopher Coleman

Submitted to the Department of Mechanical Engineering
on May 11, 2007 in Partial Fulfillment of the
Requirements for the Degree of Bachelors of Science in
Mechanical Engineering

ABSTRACT

The objective of this research is to create an inexpensive mechanism which gives wheelchair users the ability to adjust the vertical height of their chair while seated. There are currently 1.5 million manual wheelchair users in the United States. However, no manual height adjust mechanisms are available in the current marketplace. Increased vertical range of sight and reach will result in unprecedented levels of independence for wheelchair users. We applied the theory of axiomatic design as a methodology for designing a mechanism to fill this compelling unmet need. Careful consideration of the functional and physical domains guided us to an effective solution to this design problem. A proof of concept prototype was created to demonstrate the potential of this design solution. This prototype is capable of lifting a person of 250lbs weight 15 inches off of the ground while seated in the wheelchair. This design solution is viable, and with continued work we hope that it may someday come to fruition as an effective and useful product.

Thesis Supervisor: Sang-Gook Kim
Title: Associate Professor of Mechanical Engineering

ACKNOWLEDGEMENTS

We would like to thank our thesis advisor Sang-Gook Kim for the aid in developing this thesis. He provided support, suggestions, and guidance throughout the design and implementation of axiomatic design process in this wheelchair application. This guidance has given us the ability to examine engineering design problems in a systematic and structured manor. Additionally Professor Kim generously aided in the funding for this project.

Additionally, this project would not have been possible without the inspiration from both our 2.009 professors, and our 2.009 teammates. These team-mates, Darragh Buckley, Ellen Cappo, Alfredo Morales, Mike Wrick, Ruchi Jain, helped develop an initial failed prototype used for the mock-up review. The professors, Dave Wallace, Woody Flowers, and Doug Vincent helped direct the class to reconsider the social needs of disability victims. The problem solving mentality, and social benefit taught by these professors were heavily utilized in the design and construction of this thesis project.

Furthermore, we would like to thank the Pappalardo, Edgerton, and Factory Five Racing Shop facilities. Without the generous aid of individuals such as Steve Haberek, Robert Nuttal, Richard Fenner, Bob Gertsen, and Joe Cronin, the machining and fabrication of the prototype would not have been possible. These individuals provided machining advice, welding help, in addition to generous use of the Pappalardo facilities. Additionally, Colby Whipple of Factory Five Racing greatly aided in final welding of our prototype in order to make the final prototype functionally viable.

Table of Contents

ABSTRACT.....	2
ACKNOWLEDGEMENTS.....	3
Table of Contents.....	4
List of Figures.....	6
List of Tables.....	8
1.1 Motivation.....	9
1.2 Current Products.....	10
1.3 Scope.....	11
1.3.1 Previous Work.....	11
1.3.3 Thesis Outline.....	17
Chapter 2: The Design Strategies.....	19
2.1 Trial and Error Design.....	19
2.2 Axiomatic Design.....	19
2.2.1 Axiomatic Design Examples.....	22
2.2.2 The Previous Design.....	25
2.2.3 The Current Design.....	27
Chapter 3: Understanding the Problem.....	29
3.1 Key Requirements.....	29
3.2 Physical Constraints.....	33
Chapter 4: Design Implementation.....	37
4.1 Prototype Design.....	37
4.2 Transmission.....	39
4.3 Power System.....	45
4.4 Miscellaneous.....	52
4.4.1 Retraction Mechanism.....	52
4.4.2 Feet.....	53
4.4.3 Chair Attachment.....	54
4.4.4 User Interface.....	57

4.6 Conclusion and Future Work.....	60
References.....	65

List of Figures

Figure 1.1: Foam and Wood Sketch Model	13
Figure 1.2: The 2.009 Team Silver-A lifting wheelchair mockup.....	14
Figure 1.3: Speedometer cable and a hydraulic line for the 2.009 lifting wheelchair mockup. ..	15
Figure 1.4: Close up view of the 2.009 lifting wheelchair mockup.....	16
Figure 1.5: A rear view of the 2.009 lifting wheelchair mockup.....	17
Figure 2.1: A Design Matrix of functional requirements and design parameters.....	20
Figure 2.2: Functional Domain to Physical Domain Diagram	21
Figure 2.3: Dependencies of functional and physical, multiple decomposition.....	21
Figure 2.4: The proposed design solution to freezer problem	22
Figure 2.5: Design matrix for freezer problem	23
Figure 2.6: Functional and physical domain maps of food preservation example	24
Figure 2.7: Master design matrix for the food preservation example of axiomatic design.	25
Figure 2.8: Functional Requirements for 2.009 Wheelchair.....	26
Figure 2.9: Design Matrix for 2.009 Wheelchair.....	26
Figure 2.10: Design Matrix for the current design concept.	28
Figure 3.1: Spatial Availability within a normal manual wheelchair.	33
Figure 3.2 Figure Demonstrating the available armrest space.....	34
Figure 3.3: Center of Gravity shifts	35
Figure 3.4: Standard ADA dimension requirements for clearance.....	36
Figure 4.1: Completed scissor linkage for one side of the lift mechanism.....	37
Figure 4.2: Fully Extended Scissor Lift.....	38
Figure 4.3: Cantilever Beam loading.....	40
Figure 4.4: Stress distribution within the idealized construction.....	44
Figure 4.5: Stress Distribution in the actual construction.....	44
Figure 4.6: Force-body diagram of the scissor linkage and pump.....	47
Figure 4.7: Stress Distribution in front chair attachment.....	55
Figure 4.8: Photo of the sliding I-beam rollers.....	57

Figure 4.9:Free Body diagram of user interface handle	58
Figure 4.10: U bent handles vs L Bent Handles; User Interface	59
Figure 4.11: Highlighting aesthetic difference between chair and scissor.	61
Figure 4.12: Hydraulic Line Routing. Fixed line is shown in red, flexible line shown in yellow.	62
Figure 4.13: The existing hydraulic relief valve.	62
Figure 4.14: Quick release pins	63

List of Tables

Table 1.1: Current products available to wheelchair users	10
Table 3.1: Key Customer needs defined in Fall 2006.....	29
Table 4.1: Common sizes of box extrusion and U-Channel with maximum displacement.....	41
Table 4.3: Considerations for choosing a power transmission system	46
Table 4.4: Pump models.	49
Table 4.5: Pump cylinder selection options	51
Table 4.6: Scissor retraction design options	52
Table 4.7: Foot grip design parameter options	53

Chapter 1: Introduction

1.1 Motivation

This project began as part of the 2.009 design competition in the fall of 2006. Market research into products which provide independence of living for many people revealed an opening for items which can increase the range of view and reach for wheelchair users. We found that inexpensive and effective height adjustability in manual wheelchairs is a compelling unmet market need.

The University of California Disability Statistics Center estimates that as of the year 2002, there were approximately 1.5 million manual wheelchair users inside the United States [1]. The physical ability of these users varies greatly depending on individual conditions. Over 90% of wheelchair users report limitations on activities common to their age group, and as many as 56% of users report limitations in the basic task of preparing meals [1]. Traditionally, the independence of wheelchair users is often increased by adapting the living environment to meet the needs of the user within a limited reach. Many effective solutions have been devised in this manner to allow wheelchair users to cook, clean, and do many daily activities independent of outside assistance. The Americans with Disabilities Act has defined reach standards for physical spaces intended to be accessible to wheelchair users. The ADA Standards for Accessible Design sections 4.2.5 and 4.2.6 define forward reach and side reach requirements respectively:

4.2.5* Forward Reach. If the clear floor space only allows forward approach to an object, the maximum high forward reach allowed shall be 48 in (1220 mm). The minimum low forward reach is 15 in (380 mm).

4.2.6* Side Reach. If the clear floor space allows parallel approach by a person in a wheelchair, the maximum high side reach allowed shall be 54 in (1370 mm) and the low side reach shall be no less than 9 in (230 mm) above the floor [2].

However, the application of these solutions is limited in its effectiveness as it is expensive requiring a retrofit of an entire rooms and buildings. It also limits the wheelchair user to stay within adapted areas to maintain this independence. A height adjustability mechanism which allows wheelchair users to adapt their range of view and reach to many different

environments has the potential to greatly increase the independence of wheelchair users in many situations.

In recent years, explosive devices used in international warfare have yielded an unprecedented number of amputees returning from foreign conflicts. Many of these amputees are wheelchair bound, yet physically capable and independent. These wheelchair users avoid electronic and motorized devices which are often viewed as intended for severely disabled users. A mechanism which manually lifts the wheelchair would provide these users with increased range and mobility while fully maintaining their independence.

1.2 Current Products

There are currently many mobility aid devices on the market, but the problem of vertical mobility in a wheelchair is yet to be addressed inexpensively or effectively for manual wheelchair users. Table 1.1 gives an overview of the types of products available to wheelchair users.





	IBOT Mobility System	Pride Go-Chair Travel Powerchair	Flw-Weight Transport Wheelchair	Invacare Tracer IV Custom Wheelchair
Picture				
Rise-ability	Yes	No	No	No
Lower-ability	No	No	No	No
Climb stairs	Yes	No	No	No
Seat to Floor Height	21.5"	20.5"	19"	20"
Overall Length	42.9 – 46.9"	30"	40"	36"
Overall Width	25.2 – 28.7"	18.5"	20 – 22" when open, 9" when collapsed	26.5"
Battery	Two x 67.2 volt; Weight 24 lbs each;	Two x 12 volt.12Ah, 12260 Sealed Gel Battery	N/A	N/A
Weight	289 lbs	110 lbs (including batteries)	19 lbs	51 lbs
Off-road	Yes, curbs upto 5" high	No	No	No
Price	\$23,900 (promotion) \$26,100 (regularly)	\$1,449 \$2,550 regularly	\$145 \$310 regularly	\$285 \$830 regularly
Source	http://www.ibotnow.com/ibot/index.html	http://www.1800wheelchair.com/asp/view-product.asp?product_id=1317	http://www.1800wheelchair.com/asp/view-product.asp?product_id=870	http://www.1800wheelchair.com/asp/view-product.asp?product_id=123

Table 1.1: Current products available to wheelchair users

The products listed in Table 1.1 are representative of the many wheelchairs available in the current marketplace. The IBOT Mobility System provides the additional height necessary for users to reach items at a standing height and hold conversations at eye level. However, the IBOT has a prohibitive cost for most users and therefore is often associated with severe cases of disability where the necessity for assistance is great. Other chairs available on the market do not have any height adjustment feature.

While the IBOT overcomes the maximum vertical reach requirements set forth in the ADA standards, there is no product available which overcomes the minimum reach standards. If a user drops an item on the floor, he is unable to retrieve it without assistance. Many wheelchair users carry around claw arms to help them reach such items, but these claw arms can be difficult to manipulate and awkward with large items. A chair with a lowering feature could have a niche in the medical mobility device marketplace.

1.3 Scope

1.3.1 Previous Work

The initial idea for this project was conceived for the Product Engineering Processes class in the fall 2007 term. The class goal was to create products which could provide “greater independence for daily living.” During the brainstorming portion of the course, volunteers from Little Sisters of the Poor in Boston gave a presentation in which they suggested possible projects. Among these projects was a refitting of their kitchen

to better accommodate the special needs of some of their residents by, for example: (a) installing a ramp so that wheelchair riders are reasonably positioned relative to the counter or installing lower counters or (b) establishing some safety mechanism that automatically shuts off the stove after a certain period of time (unless specifically programmed to stay on) [3].

. Members of the “Silver A” team listened to this presentation, and analyzed The Little Sisters’ request to create a list of basic customer requirements. Ramps and lower counters are design parameters intended to meet the functional requirements of free access to items on top of the counters and safe access to all kitchen appliances and utensils. Refitting the kitchen is just

one possible design solution which meets these requirements. Team “Silver A” proposed a new approach: refitting the wheelchair. With improved range of the wheelchair, the user gains greater independence not only in the kitchen setting at Little Sisters of the Poor in Boston, but in any setting encountered during daily living. This may include such things as trips to the library, grocery shopping, or dining out at a restaurant.

Thus, we began work on a concept for a manually lifting wheelchair. The goal of this project was to create a low-cost chair which could provide users with greater access to raised surfaces through height adjustability. The design was developed through a trial and error process involving the creation of various mechanical elements in the machine shop and then attempting to debug the system. A foam and wood sketch model of the early design concept was created in order to better understand and visualize possible design issues. This sketch model chair could be lifted or lowered by hand along the wooden dowels seen in Figure 1.1. A representation of a hand pump was located on the right arm rest to test one possible user interface. The chair was designed to overcome the ADA minimum and maximum requirements for forward and side reach. Therefore, the model could drop below normal chair height to reach the floor, and raise up to reach higher items. A lack of space under the chair and the obtrusiveness of the linear bearings revealed that controlling the path of the chair within the geometric constraints would be a significant challenge.

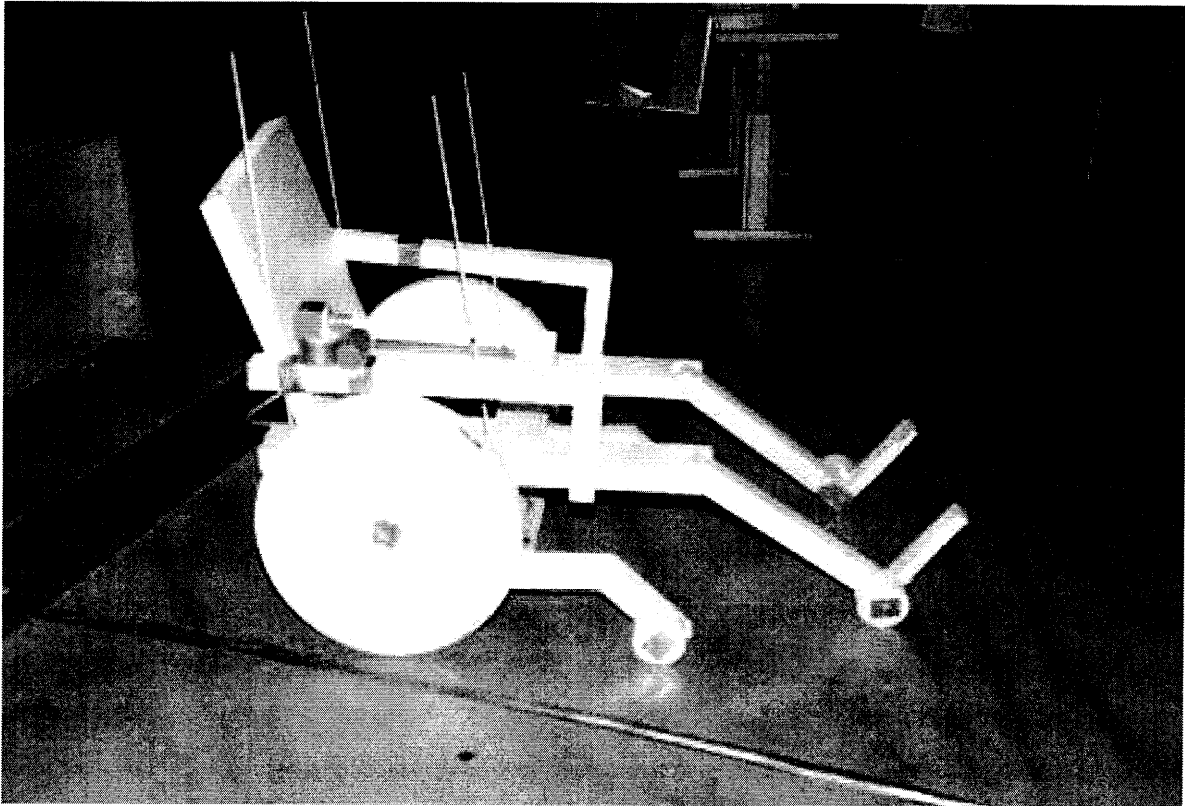

Figure 1.1: Foam and Wood Sketch Model of the Lifting Wheelchair Concept

Following the sketch model, a mockup version was created of the lifting wheelchair. This mockup was intended to be fully interactive and to demonstrate the viability of this design as a potential product. A hydraulic actuation system was utilized to provide sufficient mechanical advantage for a user to lift the chair without significant effort. The hand pump was mounted to the right armrest of the chair and could be activated with a sideways action. Ideally, it was decided that an up and down motion would be more comfortable for the user in a final design. This hand pump was connected via hydraulic tubing to the piston and scissor jack under the chair. Without any weight on the seat, the chair could be pumped up to a height of about 15 inches. A speedometer cable running from the release valve to the right armrest of the wheelchair provided a convenient release to allow the chair to be lowered.



Figure 1.2: The 2.009 Team Silver-A lifting wheelchair mockup was actuated by a hand pump mounted to the right armrest.

The hydraulic system was pieced together from several pumps which were purchased separately, and we were unable to bleed all of the air out of the system. Therefore, the pump was not able to lift the chair with a person sitting in it. The release valve was effective at lowering the chair with a person seated in it, but the resolution of the release valve allowed the user to crash uncomfortably to the floor if the valve was opened too quickly. This design would require a bumper system to slow or stop the chair comfortably, and a limit on how far the release valve can be opened.



Figure 1.3: Speedometer cable and a hydraulic line can be seen running to the modified piston which actuates the scissor jack for the 2.009 lifting wheelchair mockup.

The lifting mechanism consisted of a common scissor jack modified to meet the height requirements for this product. The arms of the jack were cut and extended by welding on steel strips. This jack was mounted on a steel plate under the chair, and bolted directly into aluminum extrusions which were added to the underside of the seat. The geometry of the steel arms provided good stability in the forward and backward directions, but the seat was unstable side to side and could tip easily due to the single attachment point. The modified jack achieved close to the desired height range, but infringed upon the normal walking space of a person pushing the wheelchair, and protruded slightly out the front of the chair posing a potential obstacle to the chair legs.



Figure 1.4: Close up view of the 2.009 lifting wheelchair mockup modified scissor jack

In order to fit the jack underneath the seat, the chair's folding apparatus was removed. This left the wheelchair torsionally unstable. In order to combat this problem, a cross brace made of aluminum extrusions was added to the rear of the chair just in front of the handles. This cross brace stabilized the chair, but became an obstacle for any person pushing the chair and would not be an acceptable final design.

Linear bearings were added to prevent the chair from moving side to side or tipping. These bearings can be seen in the rear view of the mockup. They were made from two pieces of PVC pipe which encircled the handlebars. This provided a temporary solution, but raised several potential problems. Wheelchair handles are not manufactured to great precision because they are not intended to serve as linear bearings; therefore it may be impossible to implement this design on a more precise level. Also, sliding bearings on the back of the chair will limit the range of height adjustability according to the geometry of these handlebars.

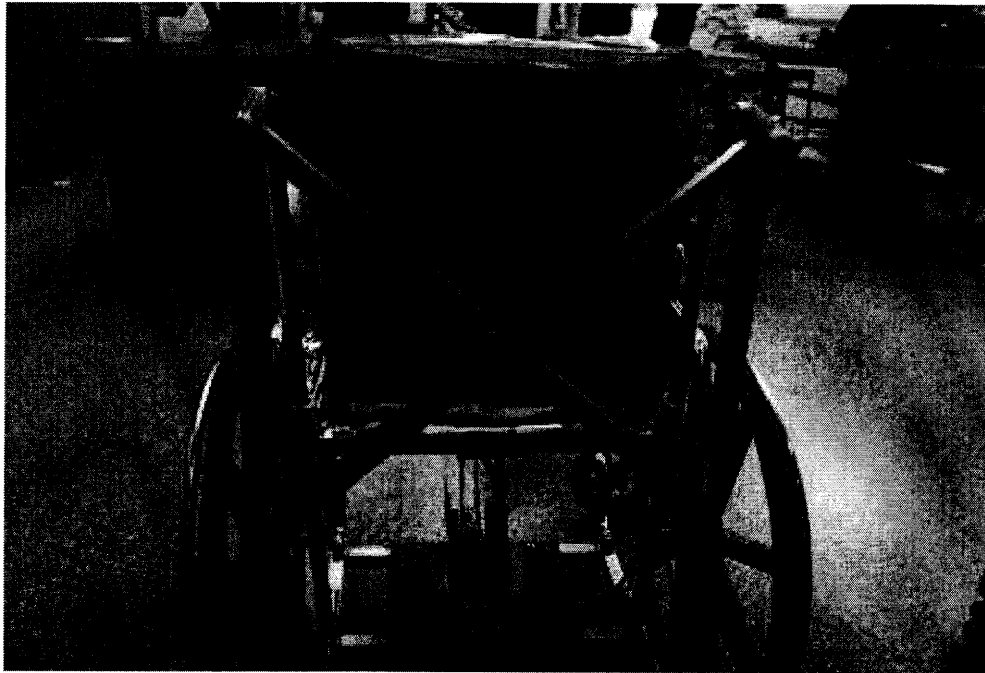

Figure 1.5: A rear view of the 2.009 lifting wheelchair mockup shows the aluminum cross brace and the PVC bearings used to stabilize the chair.

This mockup demonstrated that there may be a viable solution to the design problem of creating an affordable manual lift mechanism for a wheelchair, but that significant barriers exist to this design. Stability, reliability, and compactness stood out as key issues which must be addressed by any designer taking on this problem.

1.3.3 Thesis Outline

This thesis revisits the product concept of the manually operated wheelchair lift mechanism. Through implementation of an axiomatic design process, we developed and fabricated a proof of concept prototype. In order to design an effective and useful mechanism, we focused on four fundamental issues that were raised during 2.009, Product Engineering Processes:

1. Customer requirements defined by wheelchair operators
2. Geometric constraints of the wheelchair

3. Physical constraints of the wheelchair operator
4. Failure modes of the power transmission and lift mechanism

Based on these considerations, we defined key top-level functional requirements and constraints. These requirements were decomposed through an iterative process with a particular focus on the relationship between the functional and physical domains. Failure mode analysis and cost considerations dictated material selection for the lifting mechanism and power transmission system. The resulting prototype is composed of a hydraulic power transmission and an aluminum scissor linkage lifting mechanism which are capable of safely lifting a 250 pound person in the wheelchair, and theoretically capable of lifting up to 500 pounds.

Chapter 2: The Design Strategies

2.1 Trial and Error Design

Trial and error design, also known as “make and see” design, is a popular strategy among many product designers. This strategy relies heavily on interactive sketches, mockups, and models of design ideas to help designers obtain immediate feedback and discover flaws in their designs which may have otherwise been hidden. Often, designers will try out several different options to determine which works best for a given task. This method of design can be very effective, but is often time consuming, particularly for new designers who have not honed their ability to predict significant failure modes. Make and see designers employ many different criteria in choosing which ideas are worthy of models, there is no defined set of standards that are widely used.

2.2 Axiomatic Design

Professor Nam Suh and others developed the theory of axiomatic design based on the supposition that a structured design methodology can be applied to quickly and effectively solve design challenges. Professor Suh has published several significant works detailing the development and application of this theory [4],[5],[6]. The first step in applying this methodology to a design problem is to properly define the system constraints and functional requirements. Functional requirements (FR's) are defined as:

A minimum set of independent requirements that completely characterize the functional needs of the product in the functional domain. By definition, each FR is independent of every other FR at the time FR's are established.

Furthermore, constraints are defined as “bounds on acceptable solutions.” Constraints are further decomposed into two categories: input and system constraints. Input constraints are “imposed as part of design specifications,” while system constraints are “imposed by the system in which the design solution must function.” Before any design parameters can be selected, all of the top-level functional requirements and system constraints must be identified.

Once the basic requirements of the system have been defined, design parameters can be chosen to fulfill those requirements. The designer must rely on previous knowledge and experience, as well as his research of devices and ideas to create a thorough list of viable design options. Each set of design parameters must satisfy all of the top-level functional requirements while remaining within the system constraints. In order to select the best possible design solution, the dependencies between functional requirements and various design parameters must be mapped out and any over-constraints on the system must be identified.

Dependencies can be visualized by creating a dependency matrix which associates each design parameter with any functional requirements affected by it. If the matrix is diagonal, the design is uncoupled and all parameters can be set independently. If the matrix is triangular, the design is decoupled and a solution can be reached by setting design parameters in an appropriate order. If the matrix is not triangular, the design is coupled and there may not be an effective solution.

$$\begin{bmatrix} FR_1 \\ FR_2 \end{bmatrix} = \begin{bmatrix} X & 0 \\ 0 & X \end{bmatrix} \cdot \begin{bmatrix} DP_1 \\ DP_2 \end{bmatrix}$$

Figure 2.1: A Design Matrix is used to visualize the dependencies between functional requirements and design parameters.

Once the top level design parameters have been set, a secondary level of functional requirements can be defined for these parameters. The secondary set of requirements must be met with a secondary set of design parameters which are then considered for dependencies. This process continues until every design parameter can be fully conceived and implemented, at which time the design has been completed.

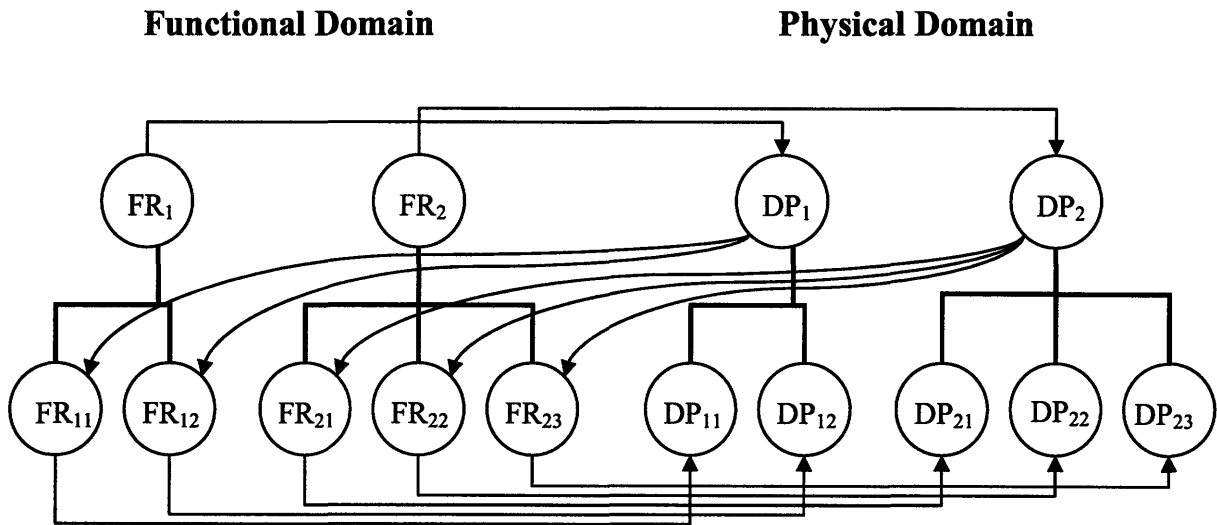

Figure 2.2: Diagram of the relationship between the functional domain (requirements) and the physical domain (design parameters.) The choice of design parameters at each level of the physical domain dictates the next level of functional requirements.

It is important to return once more to the original top level functional requirements and assure that they are still fulfilled with the design and nothing has been sacrificed along the way. A master design matrix similar to that in Figure 2.3 can help visualize the dependencies on all levels of the design.

		DP ₁		DP ₂		
		DP ₁₁	DP ₁₂	DP ₂₁	DP ₂₂	DP ₂₃
FR₁	FR ₁₂	X	0	0	0	0
	FR ₁₁	0	X	0	0	0
FR₂	FR ₁₃	0	0	X	0	0
	FR ₂₂	0	0	0	X	0
	FR ₂₁	0	0	0	0	X

Figure 2.3: A Master Design Matrix shows dependencies between the functional and physical domains on multiple levels of decomposition.

2.2.1 Axiomatic Design Examples

Nam Suh outlines several examples of axiomatic design in his book Introduction to Axiomatic Design [6]. The following food preservation example is paraphrased from Nam Suh's book. With modern technology, food can be preserved for short term or for long term use. This leads to two top level functional requirements: freeze food for long term preservation, and chill food for short term preservation. These shall henceforth be referred to as FR_1 and FR_2 respectively. These requirements can be met with two independent design parameters: a freezer section and a chiller (refrigerator) section. These shall henceforth be referred to as DP_1 and DP_2 respectively.

The freezer section has a new set of functional requirements to properly preserve food. The temperature must be controlled within a range of $-18^{\circ}\text{C}\pm 2^{\circ}\text{C}$ (FR_{11}). The temperature must be uniform throughout the freezer section (FR_{12}). The relative humidity must be held constant at 50% (FR_{13}). Note that these functional requirements are specific to the top level design parameter that was selected. In order to achieve these goals, the design must be capable of pumping chilled air in, circulating the air uniformly, and monitoring returning air for temperature and moisture, which must be controlled independently. Nam Suh suggests one possible set of design parameters to meet these needs while keeping the upper level requirements independent. A sensor and compressor system can turn a compressor on or off when the temperature of the air gets outside the range defined as acceptable (DP_{11}). An air circulation system blows air into the freezer and keeps the air evenly circulated (DP_{12}). A condenser removes moisture whenever the humidity in the freezer gets too high (DP_{13}). The design matrix can be seen in *figure 2.4*.

$$\begin{bmatrix} FR_{12} \\ FR_{11} \\ FR_{13} \end{bmatrix} = \begin{bmatrix} X & 0 & 0 \\ X & X & 0 \\ X & 0 & X \end{bmatrix} \cdot \begin{bmatrix} DP_{12} \\ DP_{11} \\ DP_{13} \end{bmatrix}$$

Figure 2.4: The proposed design solution to meet freezer functional requirements has a triangular design matrix.

The chiller section also has its own set of functional requirements in order to maintain proper performance levels. The temperature in the refrigerator must be controlled at 2°C - 3°C (FR_{21}). The air in the refrigerator must remain at a uniform temperature within 0.5°C of the

preset (FR₂₂). Design parameters must be selected to maintain the independence of these requirements as well as the upper level requirements. Again, a sensor and compressor system can turn a compressor on or off when the temperature of the air gets outside the range defined as acceptable (DP₂₁), and an air circulation system made up of fans and vents that blows air into the freezer and keeps the air evenly circulated at all times (DP₂₂). These parameters can be viewed in a design matrix as seen in *figure 2.5*.

$$\begin{bmatrix} FR_{22} \\ FR_{21} \end{bmatrix} = \begin{bmatrix} X & 0 \\ X & X \end{bmatrix} \cdot \begin{bmatrix} DP_{22} \\ DP_{21} \end{bmatrix}$$

Figure 2.5: Design matrix for the proposed design solution to meet the chiller (refrigerator) functional requirements.

This entire design process is diagrammed in *figure 2.6*. Note that the second level of functional requirements in the functional domain stemmed directly from the design choices made for the first level of requirements. In this way, the design process is iterative, passing between the functional and physical domains.

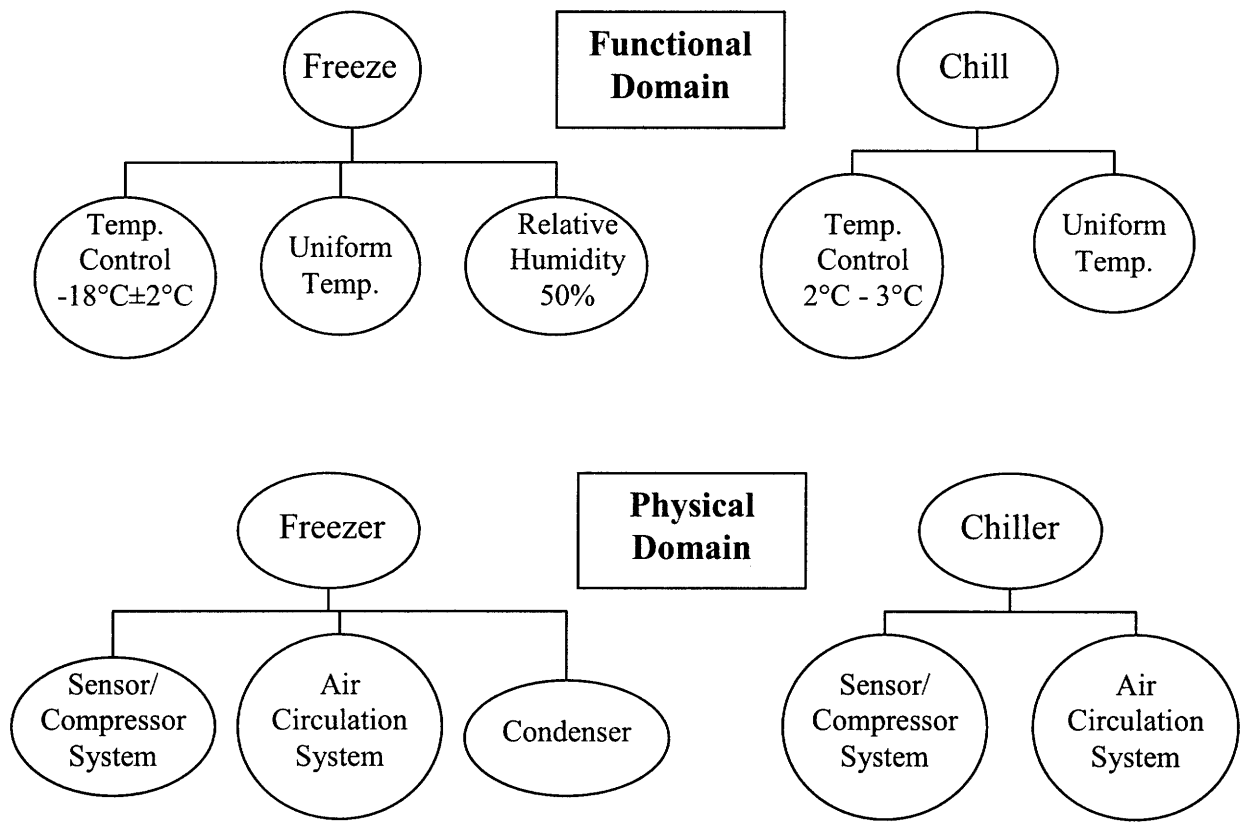

Figure 2.6: Functional and physical domain maps for the food preservation example of axiomatic design.

This design solution appears to satisfy all functional requirements in a simple and effective manner. It is important to reduce the information content of this design as much as possible to simplify the design. A good designer will now look at the master design matrix to assure that independence has been maintained on all levels of the functional and physical domains, and to discover whether any of the design parameters such as sensors and compressors can be used for multiple purposes.

		DP ₁			DP ₂	
		DP ₁₂	DP ₁₁	DP ₁₃	DP ₂₂	DP ₂₁
FR₁	FR ₁₂	X	0	0	0	0
	FR ₁₁	X	X	0	0	0
	FR ₁₃	X	0	X	0	0
FR₂	FR ₂₂	0	0	0	X	0
	FR ₂₁	0	0	0	X	X

Figure 2.7: Master design matrix for the food preservation example of axiomatic design.

As seen in Figure 2.7, this design is uncoupled on the top level. In order to reduce the information content in the design, a decoupled design can be utilized. In this case, one compressor and two fans can satisfy the design equations outlined.

2.2.2 The Previous Design

The wheelchair designed during the fall term of 2007 was intended to be manufactured and sold as a whole product: a wheelchair with vertical ability. We considered several sets of functional requirements to properly define our needs. The following six requirements are significant to the design of the lift: force applied by the user, “travel” time of the mechanism, ability to follow a defined path (vertically), range of height change, user comfort, and safety. All of these requirements must be handled within the system constraints of the wheelchair geometry and minimal production costs.

The design which was settled upon during 2.009 Product Engineering Processes can be characterized by the following relationships:

FR.1 User Force	DP.1 User Transmission
FR.2 Travel Time	DP.2 Pump Transmission
FR.3 Follows Path	DP.3 Linear Bearings
FR.4 Range of Height	DP.4 Linkage Geometry
FR.5 Comfort	DP.5 User Interface
FR.6 Safety	DP.6 Safety Mechanisms

Figure 2.8: Functional Requirements and related Design Parameters of the 2.009 manually lifting wheelchair concept

The design matrix for these parameters yields the following dependencies:

$$\begin{pmatrix} \text{FR1} \\ \text{FR2} \\ \text{FR3} \\ \text{FR4} \\ \text{FR5} \\ \text{FR6} \end{pmatrix} = \begin{pmatrix} \text{X} & \text{X} & 0 & \text{X} & 0 & 0 \\ 0 & \text{X} & 0 & \text{X} & 0 & 0 \\ 0 & 0 & \text{X} & 0 & 0 & 0 \\ 0 & 0 & 0 & \text{X} & 0 & 0 \\ 0 & 0 & 0 & 0 & \text{X} & 0 \\ 0 & 0 & 0 & 0 & 0 & \text{X} \end{pmatrix} \begin{pmatrix} \text{DP1} \\ \text{DP2} \\ \text{DP3} \\ \text{DP4} \\ \text{DP5} \\ \text{DP6} \end{pmatrix}$$

Figure 2.9: Design matrix outlining dependencies between Functional Requirements and Design Parameters of the 2.009 manually lifting wheelchair concept

This matrix is triangular, which means that the design parameters are decoupled. If there are no other constraints on the system, then this design can be solved as a series of equations. Design parameters three through six can be set to satisfy requirements three through six. Then parameter two must be set to satisfy requirement two. Finally, parameter one can be set to satisfy requirement one. This same process can be described in terms of the mechanical elements. The safety mechanisms (breaks, bumpers, stops, etc.) are completely uncoupled from other functional requirements and can be designed independently. Likewise, the user interface (seat cushion, arm rests, amenities) and the linear bearings to guide the system are entirely uncoupled. The linkage geometry must be designed to allow for the proper height range. This geometry also affects the user force required to lift and the travel time. With the linkage set, the pump transmission can be designed to lift in a reasonable time. Travel time is a function of

stroke length, or the difference in height of the chair per stroke of the pump. It is controlled by changing the ratio of surface area for the input pump to that of the activation pump. When those parameters are set, the length of the input handle (user interface) can be set, acting as a lever which provides the mechanical advantage necessary to minimize user input.

As mentioned earlier, these relationships are not as simple as this model suggests. This provides a starting point for considering the effectiveness of the design. Some additional constraints could make this strategy difficult to implement. For instance, there is a finite limit on the length of the handle to the input pump, therefore it is possible that this lever arm will not provide the necessary mechanical advantage to meet the functional requirement.

2.2.3 The Current Design

The design choices made during the fall of 2006 were revisited during the spring semester in 2007 and considered in terms of their implications within the axiomatic design framework. This served as both a lesson in applying axiomatic theory and as a launching point for the new design. Although some of the basic requirements and assertions were altered in the new design, the axiomatic method was still applied.

The final mechanism design is intended to be an add-on or retrofit for already produced wheelchairs. This will allow users to increase their vertical range without buying an entirely new chair. The functional requirements for this design have been updated from the previous version after careful consideration. The new top level requirements are as follows: “travel” time of the mechanism, ability to follow a defined path (vertically), user comfort, and safety. Range of height has been eliminated as a top level requirement because it is not fully independent of defined path. Also, user force has been reconsidered and defined as a system constraint rather than a functional requirement, because all components of the power and motion transmissions are subject to this limitation. The functional domain maps into the physical domain as outlined in *Figure 2.10*.

FR.1 Travel Time	DP.1 Pump Transmission
FR.2 Follows Path	DP.2 Linkage Geometry
FR.3 Comfort	DP.3 User Interface
FR.4 Safety	DP.4 Safety Mechanisms

Figure 2.10: Functional Requirements and related Design Parameters for the current design concept.

The design matrix for this current design is simpler, though each module must be designed carefully within the limits of the system constraints. The design matrix for this concept is diagonal, so that all components can independently fulfill a particular functional requirement. The significant challenge with this design concept is no longer satisfying the functional domain, but designing within the proper constraints of the physical domain.

Chapter 3: Understanding the Problem

3.1 Key Requirements

In fall of 2006 after a great deal of consumer research we outlined a list of basic customer requirement that we sought to meet in the design of a vertical lift wheelchair. These customer needs are outline below in table 1.

Customer Need	Attributes	Specifications
access cupboards	reach	hand height>6ft
feels secure	stability	minimum tup slope of 5%
users of all sizes	user weight	maximum of 250 lbs
mobility	chair maneuvrability	ADA specifications

Table 3.1: Key Customer needs defined in Fall 2006

Because manual wheelchair users had no method to manipulate operating height, we sought to preserve an entirely manual chair with a vertical height feature. It was critical to segregate electric from manual wheelchair users. Manual chair users normally are lower income, higher levels of athleticism, and in many instances prefer the active chair movement [7]. The product was specifically intended to change the height of manual users chairs without impacting any of the qualities they enjoyed from the manual chair operation. In defining the necessary height our chair would travel, we believed wheelchair users should have near equivalent reach as a non-wheelchair bound person. This required access to standard cupboards, shelves, stove tops, and previously inaccessible heights. If a user could reach above 6ft this would grant access to all of these regions.

Additionally, we wanted little to no sacrifice in the everyday performance of the manual chair. This meant that the chair had to accommodate the same user dimensions as well as offer

the same mobility as a normal wheelchair. To preserve mobility we further estimated that the chair needed a minimum of 5” of ground clearance to still wheelie and clear street items. Furthermore, the overall height, width, and length dimensions should not be altered in order to preserve the maneuverability. We also desired to keep overall weight as close as possible to the original wheelchair specifications. Since a normal steel bodied chair weighed near 35lbs, we sought to keep total weight under 60 lbs total in the initial 2.009 stipulations.

Furthermore, because an initial chair prototype was very unstable, we required that the next design felt secure. Initially, we loosely defined this condition that the chair would only tip over on inclines over 5 degrees. We set no initial thresholds for the chair wobbling, or for unaccounted for abrupt up and down motions of the chair. Further research in this thesis would more specifically define the criteria we had loosely defined for 2.009.

After additional research after 2.009, we laid more specific design constraints in a more specified manor for the actual lifting mechanism, outlining these functional requirements. With the general functional requirement lay out shown below in table 3.2.

FR.1 Travels Quickly
FR.2 Follows Path
FR.3 Comfort
FR.4 Safety

Table 3.2: Key outlined Functional Requirements

In setting out to re-design and re-specify our true goals from 2.009 we outlined the function requirements shown in table 2.1. The only key functional requirement which was different from a normal wheelchair was its ability to lift a user. We sought to define functional requirement through thinking about all possible needs of users, and clearly and specifically defining these needs. At the same time, we sought wording which would keep as many potential design solution open as possible, while still defining the functional applications of our end product. Each requirement heading has a distinct motivation.

The chair had to be comfortable. One portion of comfort meant that the chair had to have near-equivalent performance to a non-lifting wheelchair. The design should not have

compromised the normal use of a wheelchair such that users trade one advantage for an additional disadvantage. Instead, users would only serve to benefit from using the lifting feature. This meant that turning radiuses, rolling resistance, and normal operation had to be equivalent to the normal chair. To define this desire in the functional domain, the chair had to be non-dimensionally restrictive (meaning that the wheelchair had to have the same outward dimensions as normal). Additionally, the original motion of the wheelchair had to be preserved such that approximate forces, turning radii, and operation had to be roughly equivalent to the way the original wheelchair performed. These stipulations were difficult to set definable thresholds for, and rather were binary standards.

Comfort additionally implied that the chair was ergonomic. While this is broadly defined, ergonomics of the lifting mechanism dictate that the user interface is intuitive. This binary standard would mean that all mechanisms placed on the chair had to be familiar to the user already. Any manual lifting should be performed by natural pumping, turning, or pedaling. There should not be overcomplicated motions, procedures, or learning time to operation of the chair. If an unfamiliar user could operate the lifting mechanism instantly, the chair user interface will satisfy this functional requirement. Additionally, criticisms from 2.009 dictated that the lifting mechanism should remain aesthetically consistent with the rest of the wheelchair. While seemingly subjective, this requirement necessitated that the lifting mechanism and user interface be made of similar shapes, materials, and colors as the original wheelchair. A observer should not immediately recognize the chair as abnormal. Wheelchair users were already self-conscious, and minimizing the attraction to the chair would be beneficial. Additionally, these ergonomic requirement meant that normal wheelchair ergonomics should be unaffected by the addition of the lifting device. Handle placement, footing holds, and chair reclining, should not be affected by the addition of the device.

The chair specifically required the ability to lift users along the desired vertical path. The chair would ideally lift 15" vertically in any feasible way. This design specification stemmed from a variety of research conducted in 2.009. When users complained of being unable to reach stove-top controls, bar tables, and top shelves, we sought to alter the chair instead of the facilities. The majority of inaccessible heights to wheelchair users require only an additional 5-10" of additional height. A federal government study found that average eye height of a wheelchair user was 15-16" below an equivalent height standing individual [8]. Since most

appliances, shelving, and facilities were designed around this average distribution, an additional 15” raise in the wheelchair would equate wheelchair users to non-users in accessibility to most facilities. Yet, the rate of raising was also required to be realistic. If it took an inordinate amount of time to raise the chair, users would become frustrated and constantly conscious of their height restriction. With a rate of height change of 2” per second or more, users could access height restricted facilities in a similar time as non-wheelchair bound users.

The device also required that the user force was relatively low. This force had to be a maximum of 10lbs at the user interface. This 10 lb increment had to be exerted by upper body muscle, since foot motion was unavailable. Foot pumps, and muscles typically require higher forces due to users using weight to actuate a pump or pedal. For this device, force thresholds needed to be lowered since upper body motion typically is much lower than lower body. A 10 lb force meant that the vast majority of male and female users could easily actuate the mechanism by hand without feeling strained. Furthermore, the motion could not be fatiguing such that users preferred not to use the lifting mechanism. If force requirement were less than 10 lbs, and this force was applied for a maximum of 7.5 seconds as stipulated by the height raising requirements then fatigue would not become a concern.

Important to any consumer product design, the chair had to remain safe under all operating conditions. Although no formal regulations exist for a variable height wheelchair safety, the product would need to remain safe in all circumstances. Aside from avoiding obvious dangerous corners, and sharp bends, we sought to keep the user from tipping or dumping. At any height, or while moving towards this height the user had to be able to move in his/her ordinary way without the danger of tipping over the chair. We had stipulated that the device should only be used on level terrain, but in case the device were used on a 5° incline or more, the device should remain stable. Additionally, the probability of the a collapse, or sudden fall should be virtually zero. The device will not be acceptable to users if it potentially collapses from underneath them. Furthermore, levels of descent in the chair had to be both quick and relatively safe. If unrestricted, a fall from 15” could cause a very abrupt pain, and potentially damage the chair and user. Instead, we sought to restrict downward acceleration to 2” per second or less to ensure that the drop to ground was smooth and appeasable.

After initial brainstorming of all desirable qualities of the chair it would become important that these stipulations and descriptions remain as independent as possible. Nam Suh’s

method of Axiomatic design, discussed in detail in Chapter 2, would provide means of organizing the total functional requirements. These requirements would then dictate a design from their stipulations.

3.2 Physical Constraints

The chair was physically constrained in both spatial capacity and in the maintenance of similar safety standards. Additionally the chair still had to abide by the normal ADA safety standards outlined for wheelchair construction.

Spatial constraints dictated that all lifting components were user unobtrusive and fit entirely in the unused space within the wheelchair. Since the design sought to be an add on mechanism to most chairs, the design would resist any structural modifications to the actual chair. This left three primary spatial areas to contain the device as shown in figure 3.1.

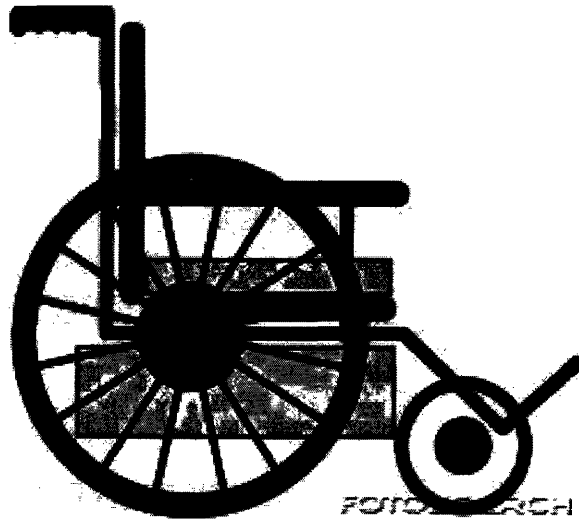

Figure 3.1: Spatial Availability within a normal manual wheelchair.

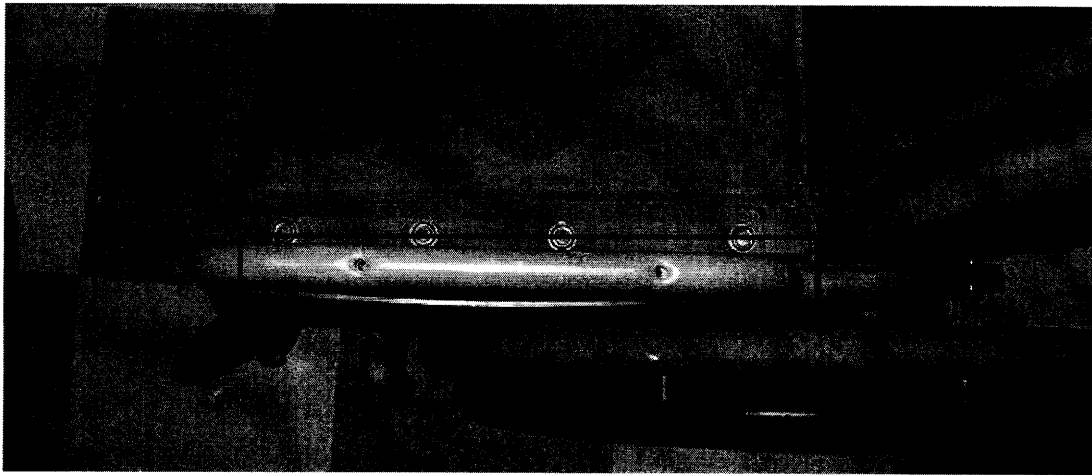

Figure 3.2 Figure Demonstrating the available armrest space

The area directly beneath the chair shall be referred to as the under-chair space. Because normal operation of the wheelchair required adequate ground clearance, and the ability to wheelie the chair to clear obstacles, the chair had to maintain 5" of overall ground clearance. Furthermore, nothing could protrude beyond seat bottom without interference with the users legs. If a wheelchair was being pushed, then no element could protrude beyond 3" of the lower frame rail. This left a total enclosed volumetric cube of 5" in height, 16.5" inches in width, and 21" in length. This area is available in the majority of manual wheelchairs [9]. The entirety of the lifting transmission mechanism had to fit within this constrained area as well as have the ability to raise the chair vertically by 15". This necessitated a minimum travel of 20" vertical inches of the device.

There were additionally two spatial areas available at each armrest. Each armrest could be replaced by a user interface, or additional device. Preservation of overall seat width dictated the overall device width. One small lengthy cubic area was available on each side of the chair, both left and right hand sides. With the armrests removed, this cubic area was 4" in width, 6" in height, and 16" in length. In this space would reside the main user interface used to operate the lifting mechanism underneath the chair. Both spaces would not necessarily need to be utilized.

In addition to these spatial constraints, the chair also had to maintain stability at any position in its travel. Roughly this meant that the center of gravity had to remain between the contact points of the device at any given time for the motion of a wheelchair user. Because pure center of gravity calculations of the human body altered dramatically dependent on limb

position, we utilized a computerized model to theoretically determine center of gravity based on limb positioning. The model was a 180 lb CAD model with an equivalent water density to provide a model of an above average male. The body portion was shifted to full outstretched and leaning forward to a almost fully reclined and reaching back position. While these extremities are not normally experienced during wheelchair use, this motion would provide safety measures in case the device was improperly used, the user would still be safely upright. Normal chair use would dictate the users keep their backs resting a slightly reclined upright, while footing stays forward and bent ahead of the chair, lying in the legrests. Additionally, arms should be able to comfortably reach the wheels or lay static on the armrest. We calculated the variation of center gravity shifts due to a variety of positions. These center of gravity shifts yielded that the two contact legs had to encompass a center of gravity shift as outlined below.

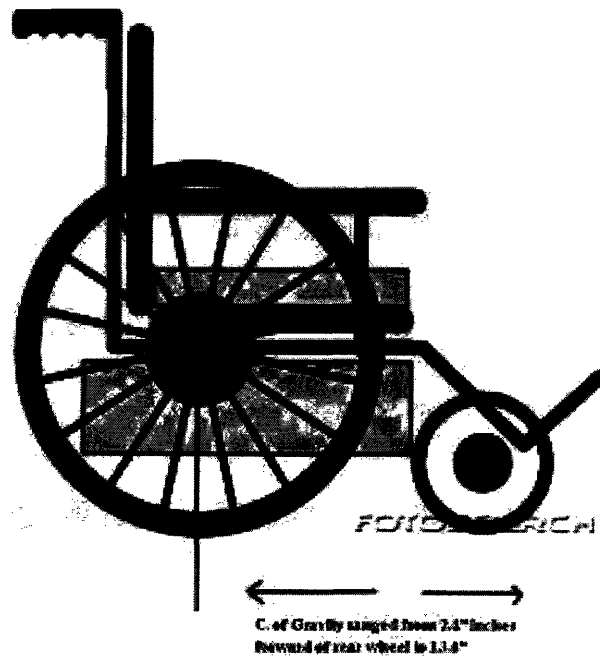

Figure 3.3: Center of Gravity shifts

Center of gravity was measured from the rear wheel line. The center of gravity under extreme condition ranged from 2.4" ahead of the rear wheel to 13.4" ahead. This calculation incorporated the weight of a 30lb device centered underneath the chair. Under normal conditions the center of gravity ranged from 3.5" to 10" ahead of the rear wheel. The height, as measured from wheel center was approximately 10-14" above wheel center depending on user height and weight.

Furthermore, in the depth dimension, Center of gravity remained between both frame cross members even under theoretically impossible body alterations.

ADA regulations were primarily intended for building code and wheelchair entry exit. Nonetheless, a wheelchair which exceeded these minimum dimensions would be useless and un-sellable. Because entrance requirements were rather generous, no ADA dimensions constraint was binding, as shown in *figure 3.4* [10].

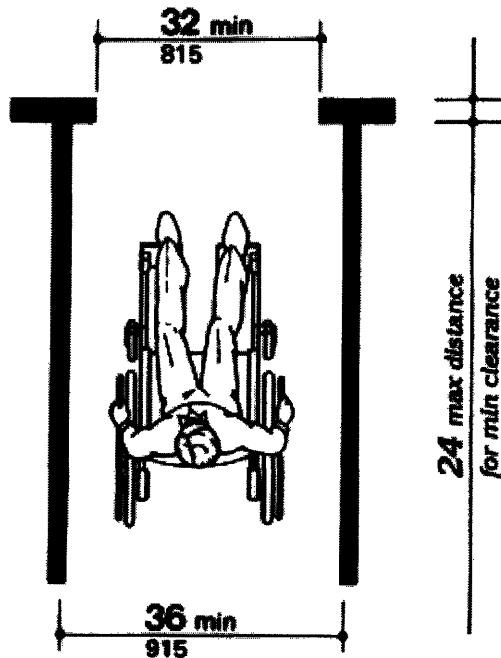

Figure 3.4: Standard ADA dimension requirements for clearance

The only restrictive portion of the ADA requirement would be in overall length requirements for door entry 24". Yet, because our design was constrained to within the normal confines of a normal wheelchair, none of these restrictions would be a hindrance or imposition.

Chapter 4: Design Implementation

4.1 Prototype Design

The prototype design for the lifting mechanism consists of two major subsystems and a few additional parts. The power system consisting of a hydraulic pump and piston provides the mechanical advantage necessary for a user to raise himself comfortably while seated in the wheelchair. The transmission system which consists of a scissor linkage mounted on track rollers locates and stabilizes the wheelchair during vertical travel.

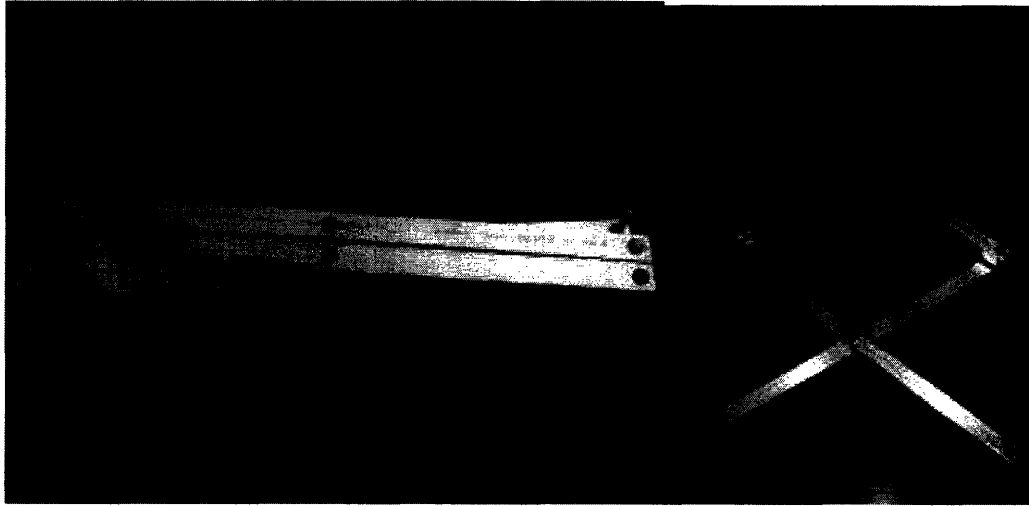

Figure 4.1: Completed scissor linkage for one side of the lift mechanism

Two adjustable height feet balance the chair, while two sliding feet allow motion of the scissor linkage. The drawing's below illustrate near completed prototype, showing the operation of the scissor mechanism and preservation of functional requirements.

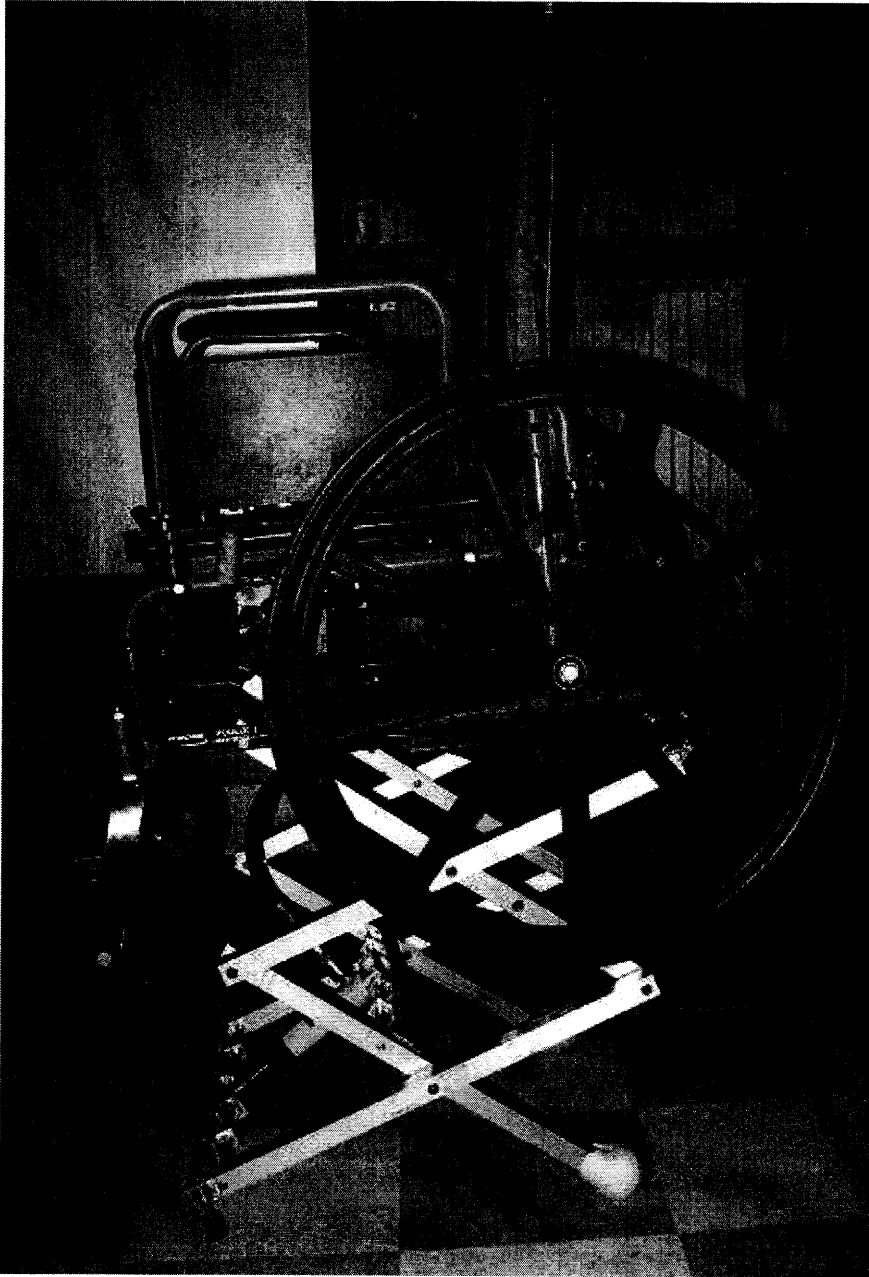

Figure 4.2: Shows the fully extended scissor lift supporting 90 lbs of weights, while showing the full 15" of ground clearance available.

The final scissor linkage appears in *figure 4.2*. The prototype successfully illustrated the feasibility of lifting an individual 15" above ground height while maintaining the functional requirements stipulated in Section 3. Detailed component design description is outline in section 4.2-4.3.

4.2 Transmission

After considering several different design options for transmitting the power supplied by the user into the desired motion, we settled on using a scissor linkage. We concluded from our market research that scissor products exist with force and height range specifications similar to our requirements, though we were unable to find any products which could fit within our size constraints underneath the wheelchair. Therefore we decided to design and fabricate our own scissor mechanism.

The geometry of the linkage was defined by the height requirement for the vertical lifter as well as the space constraints under the wheelchair. We had defined in general a scissor linkage which needed to lift 15" in vertical displacement. Additionally, the lift mechanism must fit entirely within a cubed space 16x21x10.25 (w,l,h) underneath the wheelchair. We had also wanted a minimum of 5" of spatial clearance, such that the wheelchair retained its ability to wheelie over curbs [11]. Having finalized theoretical geometric relationships of the scissor, actual tolerances, and real world performance would vary distinctly from the CAD modeled constraints.

In order to achieve 15 inches of travel or more within such a confined space, a three stage scissor linkage was necessary. Based on these considerations we were able to roughly design the scissor mechanism geometry. This rough design became the basis for a material selection process which led to the final design. Due to budget constraints, we were limited to designing a mechanism made up of readily available or easily machinable parts. Aluminum extrusions were chosen as inexpensive and effective components to make up the individual links in the mechanism.

A cost-benefit analysis of several aluminum cross sections was performed to determine which extrusions would meet our force requirements for the smallest price. In order to provide a conservative estimate for bending, each link was modeled as a cantilever fastened at the middle with a perpendicular force pushing down at the end.

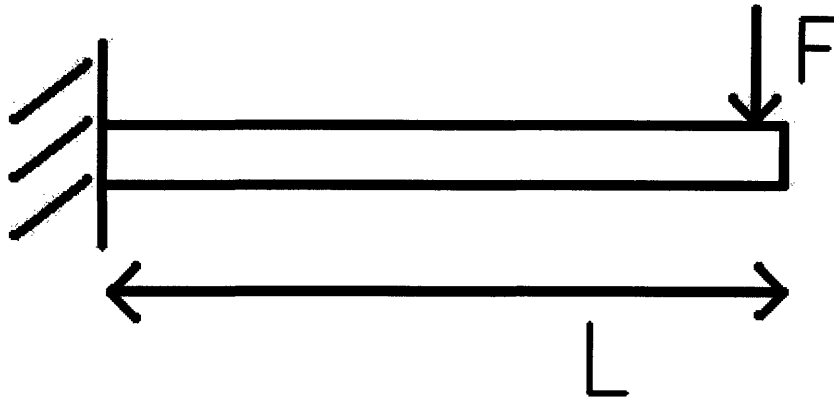

Figure 4.3: Cantilever Beam loading

The deflection at the end of the beam is described by a bending equation which depends on the material properties and the geometry of the links, particularly the area moment of inertia.

$$\delta = \frac{FL^3}{3EI} \quad (\text{eq. 4.1})$$

Table 4.1 shows the dimensions and deflection calculations for common sizes of aluminum box extrusion and u-channel.

Table 4.1: Common sizes of box extrusion and U-Channel with maximum displacement

U-Channel

Length (m)	thickness (in)	Base Length (in)	Leg Length (in)	I (m ⁴)	Force (N)	displacement (in)
0.2540005	0.0625	1	0.5	1.47E-09	200	0.419
0.2540005	0.0625	1	0.75	1.48E-09	200	0.415
0.2540005	0.125	0.75	0.375	5.98E-10	200	1.03
0.2540005	0.125	0.75	0.75	6.86E-10	200	0.895
0.2540005	0.125	1	1	2.19E-09	200	0.280
0.2540005	0.25	2	2	9.00E-08	200	0.00682
0.2540005	0.1875	2.5	1.75	9.64E-08	200	0.00637
0.2540005	0.15	4	2	3.41E-07	200	0.00180

Box

Extrusions

Length (m)	thickness (in)	Width (in)	L height (in)	I (m ⁴)	Force (N)	displacement (in)
0.2540005	0.125	0.75	0.5	8.81E-09	200	0.0698
0.2540005	0.125	1	0.75	2.37E-08	200	0.0259
0.2540005	0.062	1	0.876	1.43E-08	200	0.0431

Table 4.1: Deflection amounts for various beam cross sections

This model allowed us to initially choose 0.125” thick box extrusion 3/4 inch on a side with reasonable confidence that the displacement due to bending would be minimal even under higher loads than predicted. However, additional analysis on the 3/4” box extrusion led to several concerns. Initially deflection calculations were based on maximum loading and no inherent holes in the structure. However, holes would be present for insertion of the bushings. The aluminum 6061 tubing may have sheared under the same load condition merely due to stress concentration causing crack propagation.

After Center of Gravity Shifts had been predetermined, and confining geometry established, the actual construction task and detail selection began. We had defined in general a scissor linkage which needed to lift 15” in vertical displacement. Additionally, the lift mechanism must fit entirely within a cubed space 16x21x10.25 (w,l,h) underneath the

wheelchair. We had also wanted a minimum of 5” of spatial clearance, such that the wheelchair retained its ability to wheelie over curbs. Having finalized theoretical geometric relationships of the scissor, actual tolerances, and real world performance would vary distinctly from the CAD modeled constraints.

The first of these practical choices would be selecting the bearings used in allowing the rotation of scissor arms. We had several explicit choices which all would influence final product cost/assembly difficulty/and machine times. The Table Below Outlines the final decision making process:

Functional Requirement	Design Parameter	Tolerance (at bearing/at beam end)	Manufacturability/Assembly	Advantages	Disadvantages
2.1 Swivel motion	Bronze Oilite Bushing, Precision Steel Dowel	0.001", 0.011" [12]	Precision Aligned Holes, Expensive Shaft Grinding, Press Alignment	Lowest Tolerance	Difficult assembly, precision manufacturing
	Delrin Bushing, Stainless Bushing	0.01", 0.11"	Aligned Holes, Hand alignment	Low Cost, easy assembly and manufacturing	Wobble present, difficult to adhere, and 'cheap' feel
	Ball Bearing, Precision S.S. Dowel	0.005", .055"	Additional assembly step, hand alignment, precision shaft grinding	Easiest rotation	Extremely costly, rotational motion not critical, weakens structure, high cost for precision level

Table 4.2: Design Parameter evaluation for swivel motion needs

Because we chose to optimize tolerance over strict cost and assembly parameters, we independently chose to use the Bronze SAE 863 Oilite Bushing and Precision ground Stainless Steel shafts.

Additionally analysis on the ¾' box extrusion led to several concerns. Initially deflection calculations were based on maximum loading and no inherent holes in the structure. However, clearly holes would be present for insertion of the bushings. The aluminum 6061 tubing may have sheared under the same load condition merely due to stress concentration causing crack propagation.

Re-examination of this stress factor yielded that the tubing should be increased to 1" x 1" box extrusion to maintain adequate safety for all reasonable circumstances. The 6061 .125" wall extrusions were then precision cut and milled to allow for insertion of an 3/8" OD SAE 863 Bronze Bushing on either tubing side.

After Final assembly of one side of the large 2 stage scissor, tolerances were found to be at or below predicted standards. Rotary motion required far below expected force of 10N, and the entire half assembly weighed near 6 lbs.

Materials selection proved to be most critical in creating the connection from power system to transmission. Originally, the system was designed using only ½" Carbon Steel Rob inserted directly into bronze bushings in the aluminum. This beam was entirely too weak to take the tremendous moment exerted through the main cylinder. Peak force could range from 300-4000 lbs on the actual structure. The outrageously large forces were within the forces available to the pump, but far beyond materials limits. Thus we limited the peak experienced forces to 900 lbs to choose a suitable pump and materials for this restriction limit.

The pump would need to swivel as the scissor traveled upwards. Additionally, the pump needed to be placed directly in the center of the scissor to maintain an even force distribution in lifting both sides of the mechanism. This necessitated using round stock in the interaction of mount and pump. Ideally, the mechanism would use hardened steel 5/8" round stock with triangulated braces close to the center point. This triangulated structure would just fit within the confined of the scissor mechanism, and offer a tremendously stronger alternative than the actual constructed solution. As show below, the structure can safely support nearly 2000 lbs of force without major deformation to the aluminum it is mounted on to. The stress distribution under a

1000lb force load, shown in *figure 4.4* shows that stresses within the structure are relatively minimal.

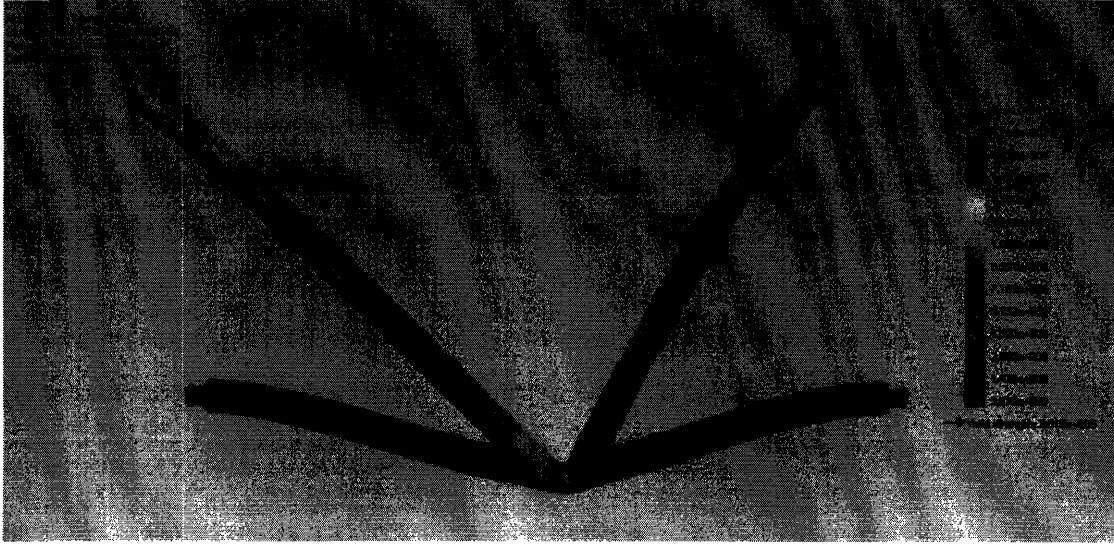

Figure 4.4: Stress distribution within the idealized construction

However, because the resources were not available to construct the 5/8" steel structure, the construction used available aluminum and 1/2" rod to generate a less sturdy solution. Using a 1"x1" aluminum beam with holed brackets to support the steel rod, the structure was adept for holding up to 650 lbs of force on the piston, or 250lbs on the wheelchair.



Figure 4.5: Stress Distribution in the actual construction

While the safety factor is not tremendous, this eyelet solution allowed adequate testing of the primary mechanisms on the chair. Stress distributions, shown in *figure 4.5* show that stress concentrations reach high levels at the beam center, where the large moment is concentrated. Unlike in the triangulated instance, the beams do not translate forces to the scissor outsides. Instead, the beams are in pure bending and the 1/8" L support brackets are in compression throughout the lift.

4.3 Power System

4.3.1 Power System Selection

After having reached a geometric lifting transmission, we now had to devise a means of powering the transmission. We had to abide by the same key constraints imposed by the scissor jack design. This meant, the device had to be both extremely compact, and non intrusive. The entire mechanism had to fit underneath the chair.

We were left with two major alternatives for the power device, either a hydraulic cylinder and pump system, or a screw jack system. The major considerations of both components are outlined below in conventional format.

Table 4.3: Considerations for choosing a power transmission system						
Functional Requirement	Design Parameter	Analysis	References		Advantages	Disadvantages
Transmission Power	Screw Jack System	Theoretically raises human 15" in 2 minutes	McMaster Carr, purgatory.mit.edu/2.007		Cheap, simple, easily changed ratio to raise	Difficult to operate (hand controls), efficiency losses, poor packaging, potential jamming
	Hydraulic Pump	Theoretically Raises human in 1.3 minutes	Enerpac, SPX	Easy to operate, intuitive and well packaged, lifetime operation.		Potential for leaks, high efficiency, heavier and bulkier.

Table 4.3 Design Parameter evaluation for Transmission Power Mechanism

Having contrasted major advantages and disadvantages between the two systems, we chose to optimize our given requirements to choose an ideal powering mechanism. We had initially desired an entire mechanism which was easy to operate, comfortable, compact, reliable, safe, and offered a lifetime usage. Although the screw jack mechanism had the potential to be more compact and variable than the hydraulic pump, the pump offered more advantages with much less chance of catastrophic failure. We then began to design more exacting specifications of this hydraulic pump.

4.3.2 Design Requirements

Having followed the axiomatic design principles outlined earlier, we had already predefined the design of the transmission scissor mechanism as side profile outlined below:

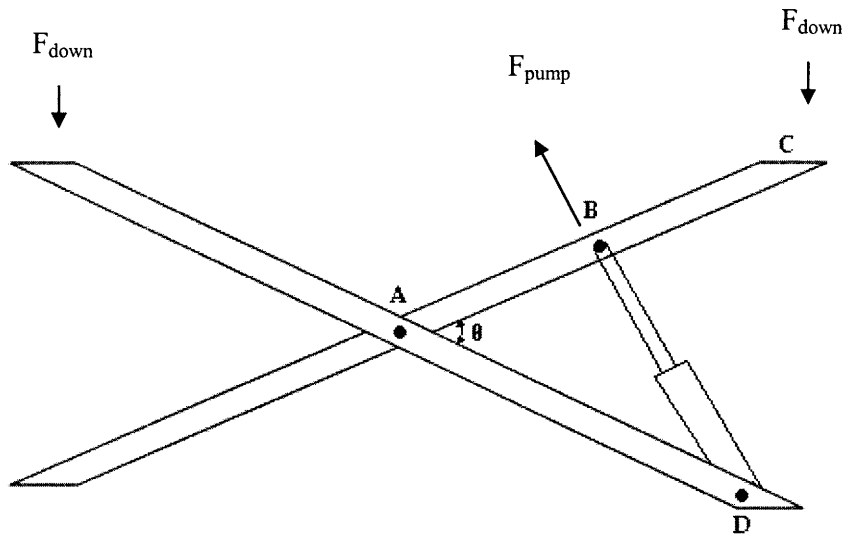

Figure 4.6: Force-body diagram of the scissor linkage and pump

Hydraulic cylinders were not available in just any size. Instead, we had to choose from a relatively large selection given in the *Appendix*. To optimize the lifting force, action, and piston size, we utilized a series of relationships and binding conditions to choose the ideal pump cylinder size.

Pump/cylinder combinations primarily had to abide by the relatively tight space constraints within the wheelchair frame. Given initial dimensions, the pump's minimum dimension was constrained by the length of the scissor transmission leg. This dimension, determined to be 10.5 inches would be the theoretical minimum piston height, also known as length L_{DBmin} while closed. Practically, the piston would need to be 9.5 inches or less at minimum extension, L_{DBmin} . Maximum extension Length of L_{DB} would be determined by piston extension length δ_{Db} . This extension length may determined through the cosine rule, given an L_{DBmax} as following.

$$L_{BD} = \sqrt{L_{AC}^2 + L_{AB}^2 - 2L_{AC}L_{AB} \cos \theta} \quad (\text{eq 4.2})$$

The range of theta θ values may be determined through full extension from 0 degrees to 63 degrees at fully extended height. The piston will not be necessary in the initial extension lengths from 0-7 inches due to no actually loading occurring on scissor tips. The scissors will only contact the ground when $\theta=19^\circ$.

The net force acting on piston cylinder can be calculated through a basic moment balance equation. From equating static moments at point D, we can determine that Piston pump force must be the following:

$$F_{pump} = \frac{L_{AC} F_{down}}{L_{AB}} \cos\left(\frac{\theta}{2}\right) \quad (\text{eq 4.3})$$

Furthermore, it is important to realize that with a large pump selection, we also wanted to maintain the most simple and effective design possible. To this end, we wanted to utilize existing crossbars at the extreme bottom of the cylinder to be used additionally for a hydraulic jack attachment point. This requirement was flexible however, if an alternative pump was to be necessary.

Pump forces would be calculated based on an absolute maximum wheelchair designed load of 250 lbs. If a user fully shifted his weight over one leg, maximum load would approach these levels for F_{down} . Additionally, it is important to realize that pump forces would be far higher than those necessary at the handle. The ratio of Cylinder to pump piston, as well as piston handle length would be critical to determining the actual at handle forces.

Table 4.4: Cylinder models. Available pumps which could have been utilized are shown in red.						
Pump Model	Piston Diameter (in)	Ext. Length (in)	Collapsed Height (in)	Oil Capacity (in3)	Weight (lbs)	Max Force (lbs)
RC-51	0.99	1	4.34	0.99	2.3	
RC-57	0.99	7	10.75	6.96	5.3	
RC-59	0.99	9.13	12.75	9.07	6.1	
RC-101	2.24	1	3.53	2.24	4	
RC-108	2.24	8	11.75	17.89	12	
RC-1010*	2.24	10.13	13.75	22.65	14	
RC-1012	2.24	12	15.75	26.84	15	
RC-1014	2.24	14	17.75	31.31	18	

Table 4.4 Specifications of Cylinder Geometry. Cylinders which fit the geometric constraints were highlighted in red. [13]

With the cylinder options currently in mind, we then had to examine existing pump availability and relations. In deciding upon a pump selection the pump was constrained to fit in a dimensionally small area, weight constrained, and had to offer adequate liquid volume flow. Pump selection was much more limited than in cylinder selection primarily because the Pump had to fit inside a 5"x6"x16" dimension in order to be mounted in place of an armrest.

To determine how to use an ideal pump, we examined the hydraulic relations between pump and cylinder combination. For a force $F_{cylinder}$, at the cylinder, the force on the pump cylinder, F_{pump} would largely be a function of the relation between pump cylinder diameter D_p and Cylinder Diameter D_c .

$$F_{pump} = F_{cylinder} \frac{D_p^2}{D_c^2} \quad (\text{eq 4.4})$$

The relation of displaced volumes followed a virtually equivalent relationship, where each pump on small pump, displaced the cylinder plunger by the following relation:

$$L_{cylinder} = L_{pump} \frac{D_p^2}{D_c^2} \quad (\text{eq 4.5})$$

The change in height of the entire device per cylinder pump, ΔH would be a functional of the scissor geometry as well as cylinder piston diameters. The ΔH would depend on the initial scissor angle, θ , as well as the angular change, δ_θ of the geometry as show below.

$$\delta_\theta = \cos^{-1} \left(-\frac{L_{cylinder}^2 + 2L_{BC}L_{cylinder}}{2L_{AC}L_{AB}} + \cos(\theta_0) \right) + \theta_0 \quad (\text{eq 4.6})$$

This angular change is necessary to calculate the actual height change of the entire device, ΔH , as follows:

$$\Delta H = 4L_{AC} \left(\sin \left(\frac{\theta_0 + \delta_\theta}{2} \right) - \sin \left(\frac{\theta_0}{2} \right) \right) \quad (\text{eq 4.7})$$

Given these relationships, we could then use our functional requirements to select an ideal pump cylinder combination.

Hydraulic cylinder selection was actually far sparser than the available cylinders. Of the devices available, only 3 pumps would fit without major alterations into the required 14"x4"x6" space available for a hand pump [14]. Of these three units, only two pumps were aluminum construction, the P142 and P141. The other available pump the P39, was constructed of steel, but had only enough liquid volume to power the smallest functional hydraulic cylinder. The Enerpac

P-142 was a dual stage pump which allowed higher pumping volumes when there was little resistance. This feature would be especially useful for lowering the of scissors when not in use. We ultimately decided upon using an Enerpac 142.

With the enerpac 142 selected, only 1” diameter cylinder pumps became viable due to volumetric flow constraints. Otherwise, we ran into two related problems. Either materials would need to be heavily fortified to support extreme loading, or the rate of movement upwards would be incredibly slow. Ultimately, we narrowed pump and cylinder selection to two choices as shown below:

Table 4.5: Pump cylinder selection options				
Pump Model	Collapsed Height (in)	Pumps Until Full Extension (approx)	Height Change per Stroke (in)	Delta Angle (radians)

Table 4.5 Specifications of height changes due to pump selection.

The RC55 and RC53 both provided good alternatives to providing upwards lift to the scissor jack mechanism. However, the RC55 seemed slightly materials constrained, as it would exert roughly 1000lbs of force on the center of an 18inch beam. The analysis of this structural loading is discussed in section 3.1, but it seemed as though too much structural support would be necessary to elevate the structure.

Ultimately, we chose the RC53 and P142 pump and cylinder combination because they ideally met the largest set of functional requirements. The combination abided by all spatial constraints imposed by the wheelchair construction, but additionally offered relatively rapid full elevation (30 pumps), as well as good incremental height changes (0.50 inches). The P-141 was ultimately ordered and used on the prototype due to budget constraints, however this pump is identical to the 142 other than the two stage pumping feature.

4.4 Miscellaneous

4.4.1 Retraction Mechanism

A retraction mechanism would allow the scissor to be quickly stored in the fully up position or placed in the down position rapidly. This feature was critical to allowing users to rapidly use their manual lift, and rapidly storing the mechanism as well to gain the required ground clearance to travel over most obstacles.

Retraction and expansion were initially treated as two independent problems while both would be controlled individually. After examining a variety of retraction mechanisms, the two basic options are outlined as follows.

Table 4.6: Scissor retraction design options					
Functional Requirement	Design Parameter	Analysis	References	Advantages	Disadvantages
4.6 Scissor Retraction	Spring return	Adequately raises mechanism in under 5 seconds	SPX, Enerpac, McMaster	Can be internalized to Cylinder, rapid user free retraction, invisible, no action required	Potential to break, Invariable retraction rate
	Lever Retraction	Adequately raises mechanism in under 2 seconds	Wheelchair brake system	User controlled rate of return, low break potential,	Requires user action, Added controls and complexity Not compact

Table 4.6 Design Parameter evaluation for Scissor Retraction

This simple pro/con valuation dictated the spring return mechanism was a much better choice than using a separately independent controlled retraction mechanism. The retraction mechanism would have added an additionally lever for operation on the wheelchair. Manual users tended not to like the added complexity or bulk. Additionally, the spring mechanism would be internally housed within the hydraulic cylinder allowing a completely invisible retraction

mechanism. This available spring was not present in our sketch-model presentation due to cost constraints at the time of construction, but the added expense in an actual production model would be lower than the addition of a lever retraction mechanism.

4.4.2 Feet

The feet of the transmission had to maximize traction, minimize added material, and adequately grip a variety of surfaces without major damage. We initially examined several footing concepts; listed below as plate, swivel feet, or swivel feet and wheels.

Table 4.7: Foot grip design parameter options					
Functional Requirement	Design Parameter	Analysis	References	Advantages	Disadvantages
4.7 Grip on a variety of surfaces at any angle	Full Flat plate (with corrugations)	Lowest distributed pressure, Most likely to be angularly upset	TBA	Low distributed pressure means unlikely to damage surfaces	Easily unstable on uneven terrain, highest weight, most complicated
	Swivel Feet (4)	High pressure distribution, least likely angular disturbance	Ladder Design, 4 step ladder	Simplest mechanism, stable under all conditions, readily available	Tradeoff of grip and surface damage
	Swivel Feet (2) Wheels (2)	Highest Pressure Distribution, lowest theoretical grip, low angular disturbance.	Automotive Scissor Lift Mechanism	Stable under all conditions, Readily available, no surface damage	Lowest amount of 'gripping' surface.

Table 4.7 Design Parameter evaluation for Surface Grip Mechanisms

Ultimately, the design which offered the highest tradeoff between surface grip, simplicity, and stability was the four swivel footed design. However, further finalizing the

footing design would involve selecting exact footing dimensions, as well as grip surface. To do so, the design would require a great deal of user and surface testing on bench level experiments. Because ladder feet inspired the design of these feet, we initially began to examine available swivel feet present on adjustable height ladders. These feet tended to be 2-4" in length and more than 1" in width with two triangular ears to attach to the actual ladder base.

Grip surfaces were largely similar. Most were plastic or rubberized footing deemed appropriate for indoor surface grip as well. Although ladder feet had to be non-scratch on slippery surfaces, our wheelchair had four feet instead of the ladder's two, and so pure tensional grip was not as large of an issue. Instead, we chose the ladder feet which seemed to do the lowest level of surface scratching to finely finished surfaces such as hardwood floors and tiles. Additionally, in order to ensure the feet were all correctly oriented during the raising procedure we verified that the counterweights at foot bottom were sufficient to keep the feet parallel to the ground surface.

4.4.3 Chair Attachment

The dimensions of the scissor lift had been designed to fit and align with the underchair-frame on the majority of manual wheelchairs. The exact nature of the attachment was desired to be unrestrictive, removable, and easily fitted. We sought to minimize the number of permanent attachments to the chair, but inevitably, the final design necessitated both the pump and guide rails remain attached to the chair permanently, resulting in a net weight increase of approximately 8 lbs.

For simplicity sake, we sought to attach ¼" shoulder bolts directly into the frame rails to act as the forward most attachment points. To determine whether this was feasible, we used Solidworks 2006 and Cosmos to perform Finite elements analysis on this torsion loaded bolts and frame rail. The finite element analysis was performed assuming a 60lb acting on the extremity of the shoulder bolt. This would be far over specified since the true maximum is approximately 50lbs and evenly distributed at the inward and outward extremity. A finite element analysis of actual loading proved that safety factors exceeded 2.0 in every portion of the design. The results of the extreme analysis are demonstrated below in *figure 4.7* with color coding showing the stress concentrations.

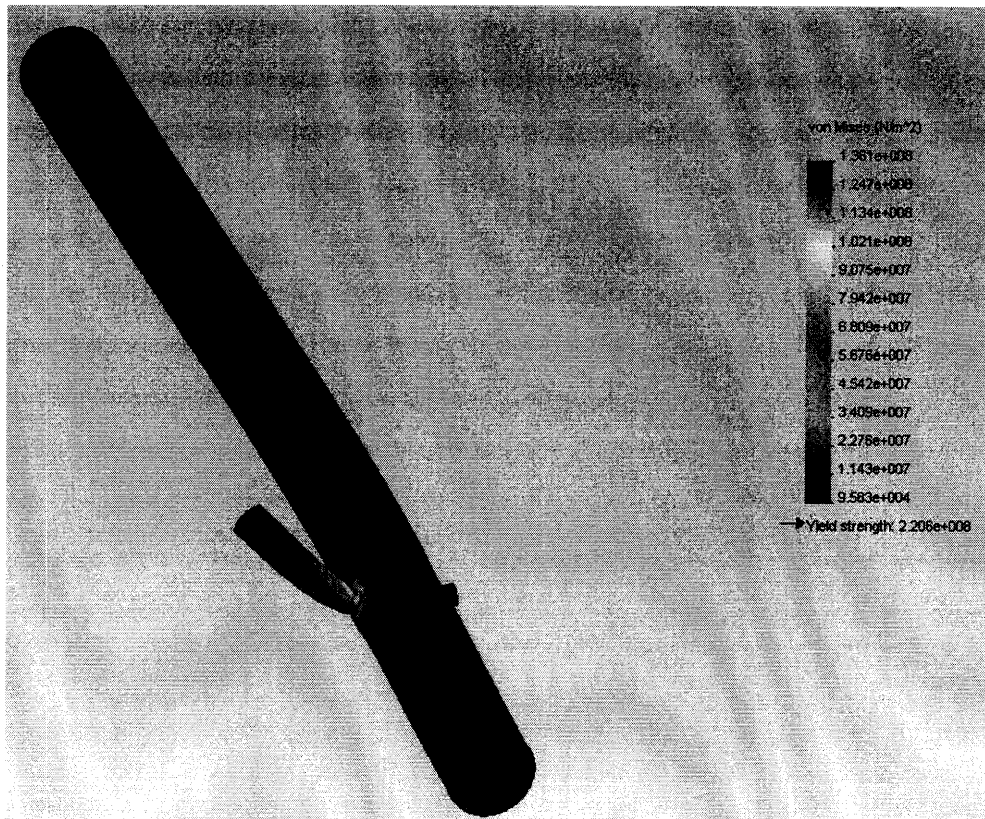

Figure 4.7: Stress Distribution in front chair attachment.

The stress distribution of *figure 4.7* demonstrates that even under the most extreme unintended uses the design retains a high safety factor. This examination also demonstrates that crack propagation is unlikely to occur. Under normal conditions, stress remains consistently below 50% of yield stress and does not undergo constant fatiguing since loading forces remain relatively constant. Satisfied with the analysis performed, we deemed that this shoulder bolt construction would allow easy construction, no debilitating wheelchair transformations, and extremely cost conscious.

The rear attachment mechanism needed to meet several requirements. This rear mount was spatially constrained in addition to stability constrained. It needed to provide stability, hold 50lbs of weight on each member, as well as slide forward and backwards to accommodate the motion of the scissor jack. We considered the following propositions for this permanently attached rail.

Functional Requirement	Design Parameter	Analysis	References	Advantages	Disadvantages
4.8 Sliding Rear Attachment	I Beam rollers	Low Friction coefficient, Supports 100lbs per pulley	McMaster, sailboat	Smooth operation, easily detachable, motion constraining	More complex, potentially higher level of deflection, adds additionally height
	External Tube Sliding	High Friction Coefficient, Supports over 100 lbs per beam	McMaster	Simple, low deflection levels, cost effective	Potential jamming, constant lubrication need,

Table 4.8 Design Parameter evaluation for Sliding rear attachments

In comparing an external sliding tube to an I beam sliding pulley, we prioritized our objectives for the design. The design had to maintain stability and safety above all other considerations. Both designs adequately met this criteria as overall deflection would be minimal (0.1” or less at full extension). Both designs would offer adequate weight support but the sliding I beam rollers would be less troublesome in an actual product. These rollers needed no maintenance over the long term since friction was minimal. Additionally, to quickly remove the mechanism required only unbolting the 2 main front bolts. Otherwise, the entire scissor can be removed from the mechanism by sliding the mechanism away. The additional complexity was not a debilitating factor. The rollers were well proven in the sailing applications without any potential durability worries.

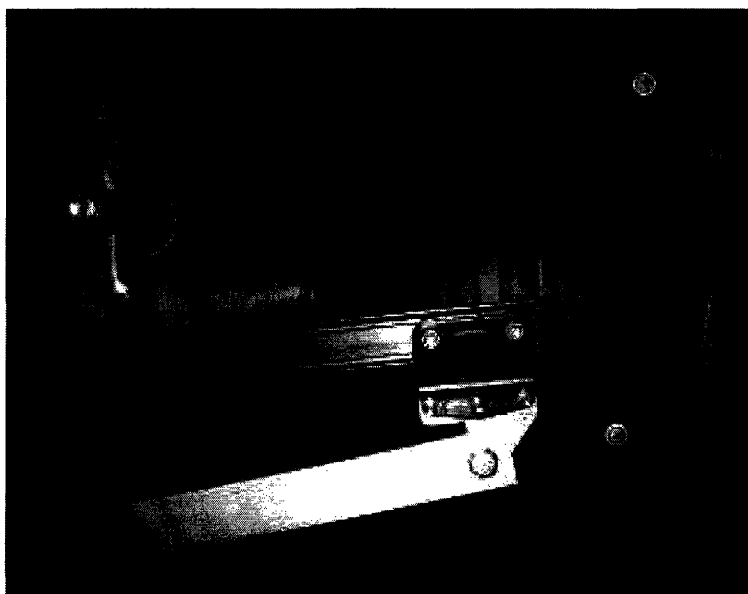

Figure 4.8: Photo of the sliding I-beam rollers.

We utilized the rollers shown above in *figure 4.8*. These devices adequately supported 550 lbs each [15]. Note that the actual I beam extends beyond the frame rail, but does not intrude upon pushing or maneuvering the chair. Additionally, note that the I beam did cause the entire scissor to be located an additional 1.5” lower to the ground. This additional distance did not interfere with maintaining 5” of total ground clearance beneath the chair.

4.4.4 User Interface

The user interface of the hydraulic lift mechanism had to meet several key function requirements as outlined earlier. We wanted the device to be intuitive to operate, relatively low forces (<10lbs by 2.009 research examinations), and unobtrusive.

Initial brainstorming led us to consider two alternate ideas. We could use a separate lever for the sole operation of the hydraulic pump or we could use an existing component of the chair as the lever for the pump. An alternate lever could provide the ability for ergonomic placement, ideal length ratio, as well as an intuitive mechanism. However, packaging a separate lever onto the chair of a length greater than 6” seemed bulky and impeding with normal wheelchair use.

Instead, the lever would double as the armrest. Through modification of the existing armrest, the user would experience no difference in normal operational usage until he wanted to

raise himself. Then, through unlatching the armrest and pumping the mechanism, he would power the hydraulic cylinder used to raise himself. When not in use, the lever appears to be identical to the armrest.

Because the armrest could be oriented to pump with the lateral shoulder muscle or triceps, we examined which alternative would be less fatiguing. Typically, females can exert on 10 lbs before ever utilizing fast twitch muscle fibers, those most prone to fatigue. At the lowest 5% this exertion is still above our desired 15lbs minimum. Although this exertion is also satisfied by lateral shoulder motion, triceps remain significantly stronger and more intuitive for a pumping motion. Thus, the design used a downward pump design motion to power the hydraulic pump. The net force experience on the pump piston was already defined to be:

$$F_{pump} = F_{cylinder} \frac{D_p^2}{D_c^2} \text{ (eq. 4.8)}$$

Net handle force would be proportional to this pump force through a direct moment relationship. The length of the handle, L_h , and length to piston L_p , would most directly affect the actual user force, F_{user} . *Figure 4.9* may clarify the interaction between user force and the length ratio used to define final user force.

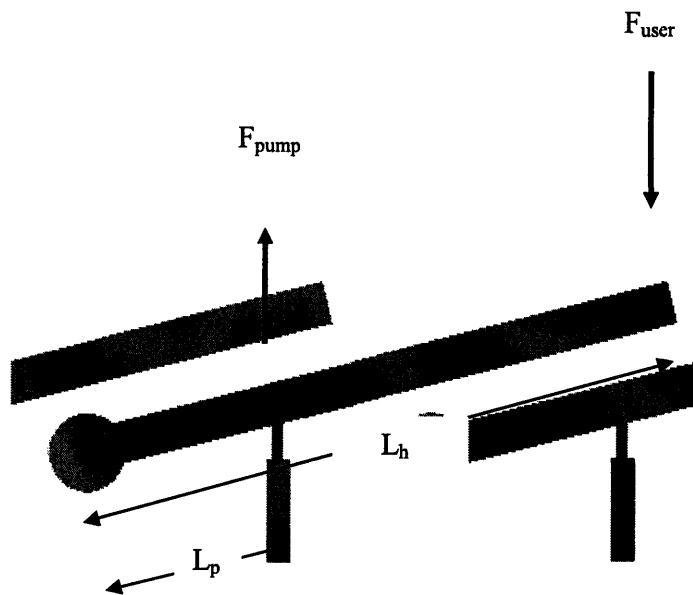

Figure 4.9: Free Body diagram of user interface handle.

This user Force then becomes:

$$F_{user} = F_{pump} \frac{L_h}{L_p} \text{ (eq 4.9)}$$

Using these equations (4.7), (4.8), (4.9), we can determine the exact interaction and interrelations between piston characteristics, handle length, and net user force. Because pump and cylinder combinations could only be varied along a finite dimension, one of the few continuous variable would be the handle length. For our particular pump and cylinder combination, total Cylinder force would at maximum be 520 lbs. With a pump cylinder force of 52 lbs, and 8 length ratio lever mechanism, end user force would only be 6.5 lbs at the final handle end location.

Although the armrest would be used for pumping actuation, there were two alternative for modification of this user interface.

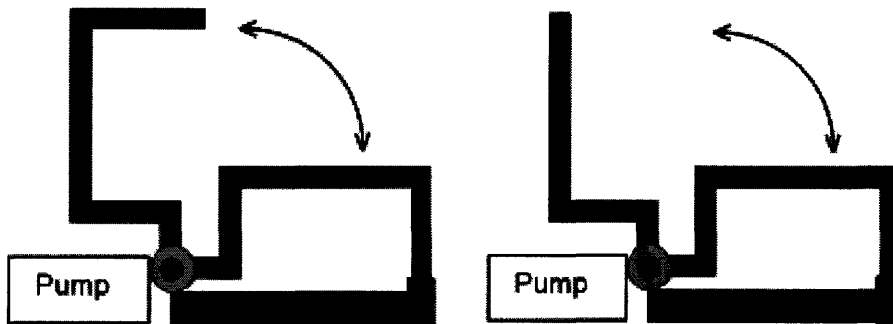

Figure 4.10: This figure illustrates the difference between using the full U bent handle as a pump, or severing the handle to create a stationary vertical piece.

The first approach would retain an shortened version of the entire handle. This would retain the original detachment feature located on the frame, and involve pumping a giant ‘U’ shaped beam over the span of 60 or more degrees. The alternative would be to sever the bar at the forward most vertical bend. This would create an L shaped pump handle, which is both lighter and more

familiar to the user. Additionally, this L shape would not lose any additional pumping force since it is an equivalent useful length. However, cutting the L shape would necessitate creating a 'snap' joint for the beam to re-connect to the lower portion of the handle.

Ultimately, the design would utilize the 'L' shaped pump handle for its more intuitive user interface and higher comfort level. When tested with the U shaped beam, the handle would often impact the frame abruptly, and re-securing the handle to the frame with the original connection was difficult, because the original connection had been designed for a vertical motion rather than angular displacement. The 'snap' joint would consist of ABS plastic which would hold the handle together unless pressure was exerted upwards. Since normal handle use never necessitated an upwards force on the handle, this seemed an uncompromised solution to provide an ergonomic, effective, and forceful solution to the pump handle.

4.6 Conclusion and Future Work

The purpose of this thesis was to prove the feasibility in using an axiomatic approach in the design of a raising wheelchair. To this end, the thesis construction and documentation were successful. However, in order to progress to a finalized product, a raising wheelchair would need a number of refinements in addition to specification changes from the construction and design listed above. The problems highlighted through the design and construction of this prototype would lead to several major developments.

Ergonomics and industrial product design were largely not considered due to cost constraints of the prototype. Instead, the end results appeared highly functional, but lacked the finish of a convincing product. As our original goals had stipulated, we wanted to keep chair aesthetics consistent with the existing wheelchair. As outlined below, the end product scissor looked like a separate attachment rather than integrated component.



Figure 4.11: Highlighting aesthetic difference between chair and scissor.

To refine the product, a scissor is still functionally required. Yet, to make the device appear consistent with the rest of the chair, we would need to use similar outer dimension tubing. Since the chair consisted largely of 1" round stock tubing, we could substitute 1/8" side wall 1" diameter aluminum tubing for the box extrusion. This change would not significantly alter strength, while greatly improving upon the overall aesthetics. Furthermore, the same geometry and use of oilite bushings could be preserved. An additional deep color such as black would disguise the contraption underneath the chair, and keep the product looking as a universal application to all wheelchairs.

Additionally, the aesthetics of the hydraulic hose routing and connection were completely ignored for the purposes of this study. In future product, the system would utilize smaller tubing diameter, in addition to a longer portion of a fixed line. As the figure below demonstrates, a fixed line would run from pump endpoint until directly under center of the chair. This tubing could be 1/4" outer diameter such as those used for brake line fittings. From here, a 1/4" NPT flexible line would loop from the fixed line to a quick connect on the hydraulic cylinder. This would keep all flexible lines underneath the chair, unable to drag, catch, or be viewed from normal view. The quick connect would allow easy connection

disconnection from the chair mechanism such that users could attach the mechanism at will. Additionally, the chair would retain its folding feature with this quick detach feature.

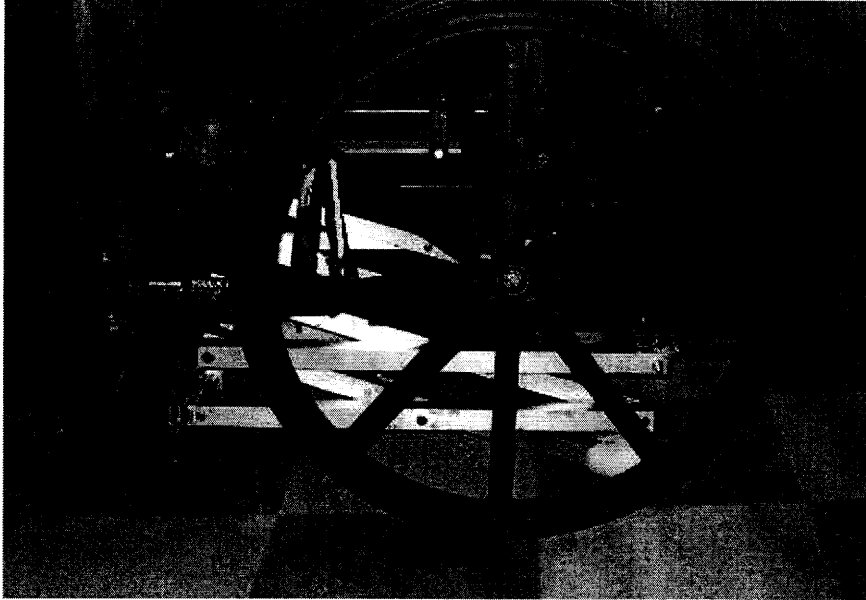

Figure 4.12: Hydraulic Line Routing. Fixed line is shown in red, flexible line shown in yellow.

Additionally, ergonomics were largely not considered on the scissor lowering mechanism. The prototype simply used the knob which was present on the existing hydraulic pump shown below. This location was relatively inaccessible when a user was fully seated, and additionally did not allow for a large range of descent rates. Instead the knob was highly sensitive allowing slight movement to vary between a rapid descent or none at all.

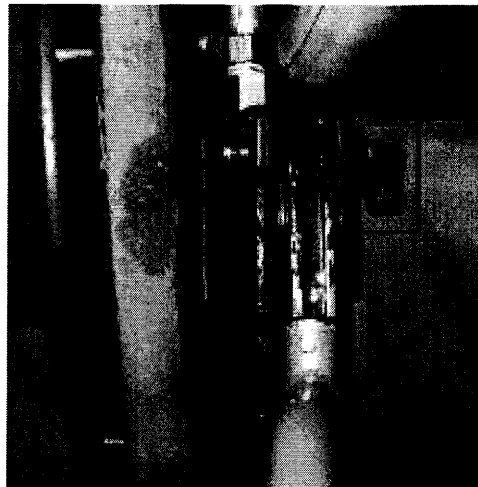

Figure 4.13: The existing hydraulic relief valve.

In further consideration of ergonomics, the relief valve should be highly variable. This may be accomplished attaching a longer length handle over a 45 degree radius turning range. Using a 3” lever placed towards the handle front would allow a great variation in descent rates over this 45 degrees. The lever would minimize force requirements to lock the system and allow easy control due to its extended length.

Furthermore, a large constraint to our entire design system was the use of standardized hydraulic components. If choices were continuous rather than discrete, the system could be more ideally optimized than the pump/cylinder combination chosen for this particular application. The choice provided slightly faster than desired lifting ability. Additionally, this particular choice met packaging and space constraint needs, while over-providing for lifting force. The geometric constraint led for total forces on the piston and piston support structure to reach near 700 lbs. This required a complex triangulated support system which added both weight and complexity. Under a continuous system, piston ratio’s could be optimized such that lifting force not require complicated support geometries, the device is well packaged, and lifting times are desirable. Ideally, the cylinder piston ratio would be closer to 1.5, with a 1.5” piston. Furthermore, If the cylinder was 4.5” with a 4” extension ratio then peak forces would be below 350 lbs, more than suitable for a single aluminum cross member. Unfortunately, this thesis was unable to machine or fabricate custom hydraulic pumps, and used a pump which demonstrated complete product feasibility and met all functional requirements.

Furthermore, in order to preserve a quick detach feature, quick connect pins should be utilized in the chair front. Here, a user could use tabbed push pins, and the hydraulic quick release to detach the under chair assembly from the wheelchair in under 30 seconds. These quick disconnect pins are shown below.

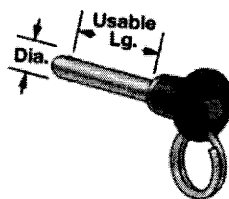

Figure 4.14: Quick release pins [16]

These ¼” pins could adequately support user weight as shown in the finite element analysis in Chapter 4. Furthermore, the pins would be safeguarded from falling off the chair because the spring loaded ball endpoints.

Additionally, the prototype did not develop the use of several necessary safety devices. Primarily, the hydraulic pump would need a flow restrictor for safety on downward descents. This choked flow device would consist of a small Schrader valve located directly at the end of the cylinder line. This would ensure that unless the cylinder sleeve itself were to burst, any hydraulic line or pump leak would not cause a sudden collapse of the mechanism. Instead, the device would safely ascend at a predefined 2”/second. Furthermore, this choked flow orifice would also limit the maximum descent possible under normal operating conditions. If a user merely cranked the relief valve to fully open the device would descend at the maximum predefined rate.

Aside from the aforementioned refinements, this thesis was able to adeptly demonstrate a proof of concept. A compact lifting wheelchair was a fully feasible proposition. Using axiomatic design principles, we were able to sufficiently meet all functional requirements unlike our previous design attempt of 2.009. The principles of design outlined in this thesis may aid in future product design.

References

[1]	H. Stephen Kaye, Taewoon Kang, and Mitchell P. LaPlante, University of California Disability Statistics Center, “ <i>Wheelchair Use in the United States</i> ”, May 2002, < http://dsc.ucsf.edu/publication.php?pub_is=1 >
[2]	Department of Justice, “ <i>Americans With Disabilities Act Standards for Accessible Design</i> ”, July 1994, < http://www.usdoj.gov/crt/ada/adastd94.pdf >
[3]	Silver Team A, “ <i>2.009 Ideas Fair Poster Session (Appendix A)</i> ”, Fall 2006, < http://web.mit.edu/2.009/www/assignments/IdeasFairResults.html >
[4]	Nam P. Suh, <i>The Principles of Design</i> . New York: Oxford University Press, Inc., 1990.
[5]	Nam P. Suh, <i>Complexity: Theory and Applications</i> . New York: Oxford University Press, Inc., 2005.
[6]	Nam P. Suh, <i>Axiomatic Design: Advances and Applications</i> . New York: Oxford University Press, Inc., 2001.
[7]	UCSF Disability Statistics Center, “ <i>Mobility Device Use in the United States; POPULATION ESTIMATES AND SOCIODEMOGRAPHIC COMPARISONS</i> ”, 2006, < http://dsc.ucsf.edu/publication.php?pub_id=2&section_id=4 >
[8]	U.S. Department of Transportation, “ <i>Characteristics of Pedestrian, Table 2.2 ‘Eye-Level Measurements for Wheelchair users</i> ”, 2007, < http://www.fhwa.dot.gov/environment/bikeped/07-chap2.pdf >
[9]	U.S. Department of Transportation, “ <i>Characteristics of Pedestrian, Table 2.1 ‘Wheelchair and Scooter Dimensions’, Washington DC</i> ”, 2007, < http://www.fhwa.dot.gov/environment/bikeped/07-chap2.pdf >

[10]	American Disabilities Act (ADA), " <i>Accessibility Guidelines for Facilities and Buildings, Space Allowance and Reach Space</i> ", 2002, http://www.access-board.gov/adaag/about/index.htm
[11]	PDQ International Ltd, " <i>Liberator Plus User Manual: Kerbs Inclines and Ramps</i> ", 2006, < http://www.pdq.tv/uploads/user_manuals/Liberator >
[12]	McMaster, " <i>SAE 841 Bronze Flanged-Sleeve Bearing for 1/4" Shaft Diameter, 3/8" OD, 1/2" Length, part number 6338K413</i> ", 2007, < www.mcmaster.com >
[13]	Enerpac, " <i>Single Acting, General Purpose Cylinders, Page 7</i> " 2006, < http://www.enerpac.com/html/products/industrial_tools/cylinders_imp/Cat_pag/RC_325US.pdf >
[14]	Enerpac, " <i>P Series Lightweight Hand Pumps, Page 63</i> ", 2006, < http://www.enerpac.com/html/products/industrial_tools/pumps_imp/Cat_pages/P_lightw_325US.pdf >
[15]	McMaster, " <i>Corrosion Resistant I-beam Trolley System,, part number 9484T21</i> ", 2007, < www.mcmaster.com >
[16]	McMaster, " <i>High Profile Push-Button Quick-Release Pin, part number 90985A115</i> ", 2007, < www.mcmaster.com >

Appendix A: Hydraulic Pump Characteristics

P-Series, Lightweight Hand Pumps



▼ Pumps shown, from top to bottom: P-802, P-842, P-202, P-142

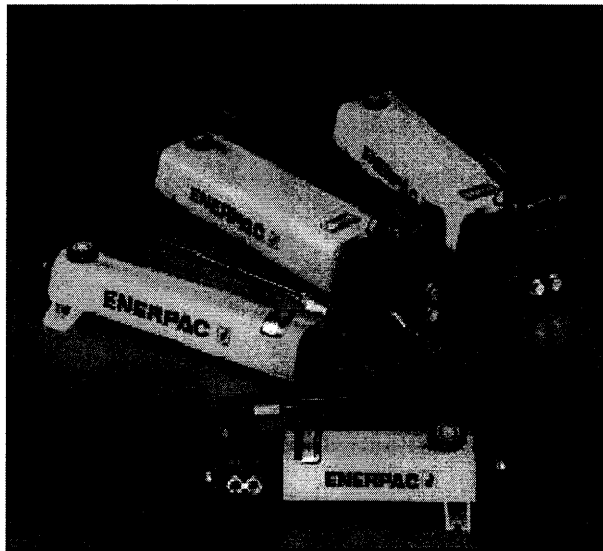

Exclusively from Enerpac

i **Cylinder Matching Chart**
For help in selecting the correct hand pump for your application, please refer to the Cylinder Matching Chart located in the "Yellow Pages".
Page: 104

i **Speed Chart**
To determine how a specific pump will operate your cylinder, see the Pump/Cylinder Speed Chart in the "Yellow Pages".
Page: 113

Tank Kits:
When a return-to-tank port is required, the Tank Kits provide a 7/16-20 port at the rear of the reservoir.

PC-20	Fits P-141, P-142
PC-25	Fits P-202, P-381, P-392

LX-101 Hand Pump Oil
A medium viscosity oil specially formulated for hand pumps. Performs well in low temperatures and requires less pumping effort than standard Enerpac HF blue oil.
Page: 120

- Lightweight and compact design
- Durable glass-filled nylon reservoir and nylon encapsulated aluminum pump base for maximum corrosion resistance
- Two-speed operation on most models reduces handle strokes by as much as 78% over single speed pumps
- Lower handle effort to minimize operator fatigue
- Integral 4-way valve on P-842 for operation of double-acting cylinders
- Handle lock and lightweight construction for easy carrying
- Large oil capacities to power a wide range of cylinders or tools
- Non-conductive fiberglass handle for operator safety
- Internal pressure relief valve for overload protection

▼ P-392 in action with RSM-500 cylinders.



Pump Type	Usable Oil Capacity (in ³)	Model Number	Pressure Rating* (psi)		Oil Displacement per Stroke (in ³)		Max. Handle Effort (lbs)
			1 st stage	2 nd stage	1 st stage	2 nd stage	
Single-speed	20	P-141	N/A	10,000	N/A	.055	72
	55	P-381	N/A	10,000	N/A	.151	85
Two-speed	20	P-142**	200	10,000	.221	.055	78
	55	P-202	200	10,000	.221	.055	63
	55	P-382**	200	10,000	.687	.151	93
	155	P-802	400	10,000	2.40	.151	95
	155	P-842**	400	10,000	2.40	.151	95

* Contact Enerpac for applications where operating pressure is less than 10% of pressure rating.
** Available as set, see note on top of next page.
*** For use with double-acting cylinders.

Lightweight Hand Pumps



Pump and Cylinder sets
Pumps marked with an * are available as sets (pump, cylinder, gauge, couplers and hose) for your ordering convenience. Page: 58

P Series



Reservoir Capacity:
20-155 in³

Flow at Rated Pressure:
.055-.15 in³/stroke

Maximum Operating Pressure:
10,000 psi

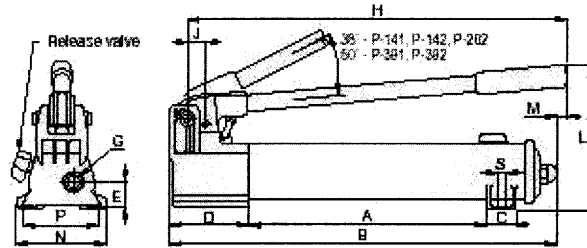

P-141, P-142, P-202, P-391, P-392

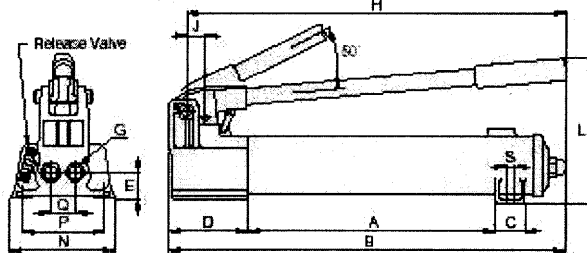

P-902

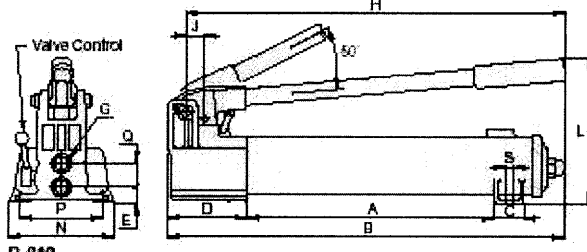

P-942



Hoses
Enerpac offers a complete line of high-quality hydraulic hoses. To ensure the integrity of your system, specify only genuine Enerpac hydraulic hoses. Page: 116



Gauges
Minimize the risk of overloading and ensure long, dependable service from your equipment. Refer to the System Components section for a full range of gauges. Page: 122



Aluminum Reservoir
For applications where composite reservoirs may not be suitable, the P-392AL utilizes an extruded aluminum reservoir. Also included is a second handle for two-hand use. Contact Enerpac for details.

Piston Stroke	Dimensions (in)														Weight (lbs)	Model Number
	(in)	A	B	C	D	E	G	H	J	L	M	N	P	Q		
.50	7.31	13.25	1.13	3.37	1.13	1/4"-18 NPTF	12.56	.75	5.63	-	3.75	3.18	-	.28	5.3	P-141
1.00	13.56	21.00	1.44	3.93	1.31	3/8"-18 NPTF	20.56	1.19	7.00	.63	4.75	-	-	-	9.0	P-391
.50	7.31	13.25	1.13	3.37	1.13	1/4"-18 NPTF	12.56	.75	5.63	-	3.75	3.18	-	.28	5.3	P-142*
.50	13.56	20.06	1.44	3.37	1.13	1/4"-18 NPTF	15.75	.75	5.69	.63	3.75	-	-	-	7.5	P-202
1.00	13.56	21.00	1.44	3.93	1.31	3/8"-18 NPTF	20.56	1.19	7.00	.63	4.75	-	-	-	9.0	P-392*
1.00	13.30	21.75	1.78	5.25	1.99	3/8"-18 NPTF	20.75	2.19	9.00	-	7.12	4.75	1.40	.41	18.0	P-902
1.00	13.30	21.75	1.78	5.25	.81	3/8"-18 NPTF	20.75	2.19	9.00	-	7.12	4.75	1.44	.41	22.0	P-942

Appendix B: Hydraulic Cylinder Characteristics

Single-Acting, General Purpose Cylinders



Think Safety
 Manufacturer's rating of load and stroke are maximum safe limits.
 Good practice encourages using only 80% of these ratings!

Page: 106

▼ **QUICK SELECTION CHART**
 For complete technical information see next page.

Cylinder Capacity tons (MAXIMUM)	Stroke (in)	Model Number	Cylinder Effective Area (in ²)	Oil Capacity (in ³)	Collapsed Height (in)	Weight (lbs)
5 (4.9)	.63	RC-50*	.99	.62	1.63	2.2
	1.00	RC-51	.99	.99	4.34	2.3
	3.00	RC-53	.99	2.98	6.50	3.3
	5.00	RC-55*	.99	4.97	8.50	4.1
	7.00	RC-57	.99	6.96	10.75	5.3
10 (11.2)	1.00	RC-101	2.24	2.24	3.53	4.0
	2.13	RC-102*	2.24	4.75	4.78	5.1
	4.13	RC-104	2.24	9.23	6.75	7.2
	6.13	RC-106*	2.24	13.70	9.75	9.8
	8.00	RC-108	2.24	17.89	11.75	12.0
	10.13	RC-1010*	2.24	22.65	13.75	14.0
16 (15.7)	12.00	RC-1012	2.24	26.84	15.75	15.0
	14.00	RC-1014	2.24	31.31	17.75	18.0
	1.00	RC-151	3.14	3.14	4.88	7.2
	2.00	RC-152	3.14	6.28	5.88	9.0
	4.00	RC-154*	3.14	12.57	7.88	11.0
	6.00	RC-156*	3.14	18.85	10.69	15.0
25 (25.8)	8.00	RC-158	3.14	25.13	12.69	18.0
	10.00	RC-1610	3.14	31.42	14.69	21.0
	12.00	RC-1612	3.14	37.70	16.69	24.0
	14.00	RC-1614	3.14	43.98	18.69	26.0
	1.00	RC-251	5.16	5.16	5.50	13.0
	2.00	RC-252*	5.16	10.31	6.50	14.0
30 (32.4)	4.00	RC-254*	5.16	20.63	8.50	18.0
	6.25	RC-256*	5.16	32.23	10.75	22.0
	8.25	RC-258	5.16	42.55	12.75	27.0
	10.25	RC-2510	5.16	52.86	14.75	31.0
	12.25	RC-2512	5.16	63.18	16.75	36.0
	14.25	RC-2514*	5.16	73.49	18.75	39.0
50 (55.2)	8.25	RC-308	6.49	53.56	15.25	40.0
	2.00	RC-502	11.04	22.09	6.94	33.0
	4.00	RC-504	11.04	44.18	8.94	42.0
	6.25	RC-506*	11.04	66.03	11.13	51.0
75 (79.5)	13.25	RC-5015	11.04	146.34	18.13	83.0
	6.13	RC-758	15.90	97.41	11.25	65.0
100 (103.1)	13.13	RC-7513	15.90	208.74	19.38	130.0
	6.63	RC-1006	20.63	136.67	14.06	130.0
	10.25	RC-10010	20.63	211.45	17.69	160.0

* Available as a set. See note on this page.
 ** RC-50 cylinder has non-removable grooved saddle and no collar thread.

RC Series

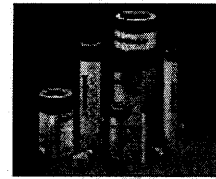

Capacity:
5-100 tons

Stroke:
.63-14.25 inches

Maximum Operating Pressure:
10,000 psi



Extreme Environment Products
 Designed for use in applications where frequent washdowns, cleaning chemicals, water and fluids cause rust and corrosion of painted steel components.

Page: 12



RAC-Series, Single-Acting Cylinders
 The lightweight general purpose spring return aluminum cylinders.

Page: 12



Gauges
 Minimize the risk of overloading and ensure long, dependable service from your equipment. Refer to the System Components section for a full range of gauges.

Page: 122



Pump and Cylinder Sets
 All cylinders marked with an * are available as sets (cylinder, gauge, couplers, hose and pump) for your ordering convenience.

Page: 58

RC-Series, Single-Acting Cylinders

ENERPAC
Hydraulic Technology Worldwide

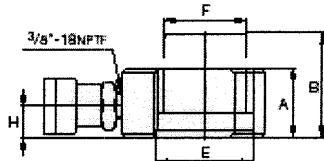
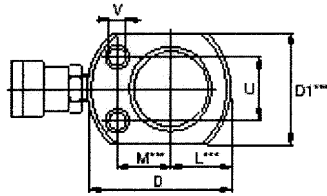

RC-50

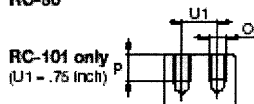

RC-101 only
(U1 = .75 inch)

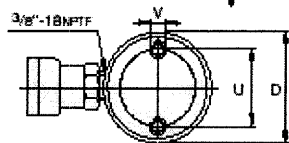
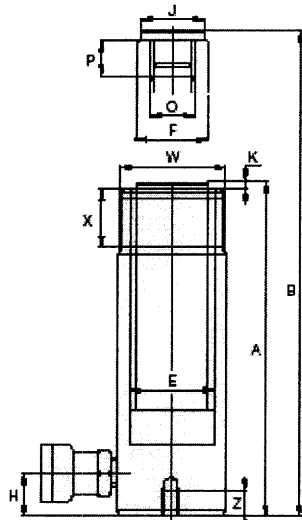

RC-51 to RC-7513 models

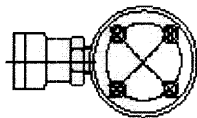

RC-1006 and RC-10010 models

i **Speed Chart**
See the Enerpac Cylinder Speed Chart in our "Yellow Pages" to determine your approximate cylinder speed.
Page: 113

◀ For full features see page 6.

Cylinder Capacity Tons (maximum)	Stroke (in)	Model Number	Cylinder Effective Area (in ²)	Oil Capacity (in ³)	Collapsed Height A (in)	Extended Height B (in)	Outside Diameter D (in)
5 (4.9)	.63	RC-50*	.99	.62	1.63	2.25	2.31
	1.00	RC-51	.99	.99	4.34	5.34	1.50
	3.00	RC-53	.99	2.98	6.50	9.50	1.50
	5.00	RC-55*	.99	4.97	8.50	13.50	1.50
	7.00	RC-57	.99	6.96	10.75	17.75	1.50
	9.13	RC-59	.99	9.07	12.75	21.88	1.50
10 (11.2)	1.00	RC-101	2.24	2.24	3.53	4.53	2.25
	2.13	RC-102*	2.24	4.75	4.78	6.91	2.25
	4.13	RC-104	2.24	9.23	6.75	10.88	2.25
	6.13	RC-106*	2.24	13.70	8.75	15.88	2.25
	8.00	RC-108	2.24	17.89	11.75	19.75	2.25
	10.13	RC-1010*	2.24	22.65	13.75	23.88	2.25
	12.00	RC-1012	2.24	26.84	15.75	27.75	2.25
	14.00	RC-1014	2.24	31.31	17.75	31.75	2.25
15 (15.7)	1.00	RC-151	3.14	3.14	4.88	5.88	2.75
	2.00	RC-152	3.14	6.28	5.88	7.88	2.75
	4.00	RC-154*	3.14	12.57	7.88	11.88	2.75
	6.00	RC-156*	3.14	18.85	10.69	16.69	2.75
	8.00	RC-158	3.14	25.13	12.69	20.69	2.75
	10.00	RC-1510	3.14	31.42	14.69	24.69	2.75
	12.00	RC-1512	3.14	37.70	16.69	28.69	2.75
	14.00	RC-1514	3.14	43.98	18.69	32.69	2.75
25 (25.8)	1.00	RC-251	5.16	5.16	5.50	6.50	3.38
	2.00	RC-252*	5.16	10.31	6.50	8.50	3.38
	4.00	RC-254*	5.16	20.63	8.50	12.50	3.38
	6.25	RC-256*	5.16	32.23	10.75	17.00	3.38
	8.25	RC-258	5.16	42.55	12.75	21.00	3.38
	10.25	RC-2510	5.16	52.86	14.75	25.00	3.38
	12.25	RC-2512	5.16	63.18	16.75	29.00	3.38
	14.25	RC-2514*	5.16	73.49	18.75	33.00	3.38
30 (32.4)	8.25	RC-308	6.49	53.56	15.25	23.50	4.00
50 (55.2)	2.00	RC-502	11.04	22.09	6.94	8.94	5.00
	4.00	RC-504	11.04	44.18	8.94	12.94	5.00
	6.25	RC-506*	11.04	66.03	11.13	17.38	5.00
	13.25	RC-5013	11.04	146.34	18.13	31.38	5.00
75 (79.5)	6.13	RC-756	15.90	97.41	11.25	17.38	5.75
	13.13	RC-7513	15.90	208.74	19.38	32.50	5.75
100 (103.1)	6.63	RC-1006	20.63	136.67	14.06	20.69	7.00
	10.25	RC-10010	20.63	211.45	17.69	27.94	7.00

* Available as a set. See page 58.

** RC-50 cylinder has non-removable grooved saddle and no collar thread.

*** D1 = 1.63 inch, L = .81 inch, M = 1.00 inch.

Single-Acting, General Purpose Cylinders

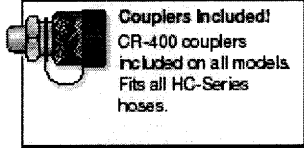

Capacity:
5-100 tons

Stroke:
.63-14.25 inches

Maximum Operating Pressure:
10,000 psi

RC Series

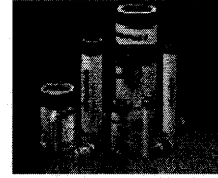

Cylinder Bore Diam. E (in)	Plunger Diam. F (in)	Base to Adv. Port H (in)	Saddle Diam. J (in)	Saddle Protrusion from Plng. K (in)	Plunger Internal Thread O (in)	Plunger Thread Length P (in)	Base Mounting Holes			Collar Thread W (in)	Collar Thread Length X (in)	Weight (lbs)	Model Number
							Bot Circle U (in)	Thread V (in)	Thrd. Depth Z (in)				
1.13	1.00	.75	—	—	—	—	1.13	.22	—	—	—	2.2	RC-50*
1.13	1.00	.75	1.00	.25	3/4"-16	.56	1.00	1/4"-20UN	.56	1 1/2"-16	1.13	2.3	RC-51
1.13	1.00	.75	1.00	.25	3/4"-16	.56	1.00	1/4"-20UN	.56	1 1/2"-16	1.13	3.3	RC-53
1.13	1.00	.75	1.00	.25	3/4"-16	.56	1.00	1/4"-20UN	.56	1 1/2"-16	1.13	4.1	RC-55*
1.13	1.00	.75	1.00	.25	3/4"-16	.63	1.00	1/4"-20UN	.56	1 1/2"-16	1.13	5.3	RC-57
1.13	1.00	.75	1.00	.25	3/4"-16	.63	1.00	1/4"-20UN	.56	1 1/2"-16	1.13	6.1	RC-59
1.69	1.50	.75	—	—	#10-24UN	.25	1.56	3/8"-18UN	.50	2 1/4"-14	1.06	4.0	RC-101
1.69	1.50	.75	1.38	.25	1"-8	.75	1.56	3/8"-18UN	.50	2 1/4"-14	1.13	5.1	RC-102*
1.69	1.50	.75	1.38	.25	1"-8	.75	1.56	3/8"-18UN	.50	2 1/4"-14	1.06	7.2	RC-104
1.69	1.50	.75	1.38	.25	1"-8	.75	1.56	3/8"-18UN	.50	2 1/4"-14	1.13	9.8	RC-106*
1.69	1.50	.75	1.38	.25	1"-8	.75	1.56	3/8"-18UN	.50	2 1/4"-14	1.06	12	RC-108
1.69	1.50	.75	1.38	.25	1"-8	.75	1.56	3/8"-18UN	.50	2 1/4"-14	1.13	14	RC-1010*
1.69	1.50	.75	1.38	.25	1"-8	.75	1.56	3/8"-18UN	.50	2 1/4"-14	1.06	15	RC-1012
1.69	1.50	.75	1.38	.25	1"-8	.75	1.56	3/8"-18UN	.50	2 1/4"-14	1.06	18	RC-1014
2.00	1.63	.75	1.50	.38	1"-8	1.00	1.88	3/8"-16UN	.50	2 3/4"-16	1.19	7.2	RC-151
2.00	1.63	.75	1.50	.38	1"-8	1.00	1.88	3/8"-16UN	.50	2 3/4"-16	1.19	9	RC-152
2.00	1.63	.75	1.50	.38	1"-8	1.00	1.88	3/8"-16UN	.50	2 3/4"-16	1.19	11	RC-154*
2.00	1.63	1.00	1.50	.38	1"-8	1.00	1.88	3/8"-16UN	.50	2 3/4"-16	1.19	15	RC-156*
2.00	1.63	1.00	1.50	.38	1"-8	1.00	1.88	3/8"-16UN	.50	2 3/4"-16	1.19	18	RC-158
2.00	1.63	1.00	1.50	.38	1"-8	1.00	1.88	3/8"-16UN	.50	2 3/4"-16	1.19	21	RC-1510
2.00	1.63	1.00	1.50	.38	1"-8	1.00	1.88	3/8"-16UN	.50	2 3/4"-16	1.19	24	RC-1512
2.00	1.63	1.00	1.50	.38	1"-8	1.00	1.88	3/8"-16UN	.50	2 3/4"-16	1.19	26	RC-1514
2.56	2.25	1.00	2.00	.41	1 1/2"-16	1.00	2.31	1/2"-13UN	.75	3 3/8"-12	1.94	13	RC-251
2.56	2.25	1.00	2.00	.41	1 1/2"-16	1.00	2.31	1/2"-13UN	.75	3 3/8"-12	1.94	14	RC-252*
2.56	2.25	1.00	2.00	.41	1 1/2"-16	1.00	2.31	1/2"-13UN	.75	3 3/8"-12	1.94	18	RC-254*
2.56	2.25	1.00	2.00	.41	1 1/2"-16	1.00	2.31	1/2"-13UN	.75	3 3/8"-12	1.94	22	RC-256*
2.56	2.25	1.00	2.00	.41	1 1/2"-16	1.00	2.31	1/2"-13UN	.75	3 3/8"-12	1.94	27	RC-258
2.56	2.25	1.00	2.00	.41	1 1/2"-16	1.00	2.31	1/2"-13UN	.75	3 3/8"-12	1.94	31	RC-2510
2.56	2.25	1.00	2.00	.41	1 1/2"-16	1.00	2.31	1/2"-13UN	.75	3 3/8"-12	1.94	36	RC-2512
2.56	2.25	1.00	2.00	.41	1 1/2"-16	1.00	2.31	1/2"-13UN	.75	3 3/8"-12	1.94	39	RC-2514*
2.88	2.25	2.25	2.00	.41	1 1/2"-16	1.00	—	—	—	3 3/8"-12	1.94	40	RC-308
3.75	3.13	1.31	2.81	.11	—	—	3.75	1/2"-13UN	.75	5"-12	2.19	33	RC-502
3.75	3.13	1.31	2.81	.11	—	—	3.75	1/2"-13UN	.75	5"-12	2.19	42	RC-504
3.75	3.13	1.38	2.81	.11	—	—	3.75	1/2"-13UN	.75	5"-12	2.19	51	RC-506*
3.75	3.13	1.38	2.81	.11	—	—	3.75	1/2"-13UN	.75	5"-12	2.19	83	RC-5018
4.50	3.75	1.19	2.81	.23	—	—	—	—	—	5 3/4"-12	1.75	65	RC-758
4.50	3.75	1.19	2.81	.23	—	—	—	—	—	5 3/4"-12	1.75	130	RC-7518
5.13	4.13	1.63	2.81	.11	—	—	5.50	3/4"-10UN	1.00	6 3/4"-12	1.75	130	RC-1008
5.13	4.13	1.63	2.81	.11	—	—	5.50	3/4"-10UN	1.00	6 3/4"-12	1.75	160	RC-10010

Appendix C: Machined Part Drawings

Part List

Part	Quantity	Material	Source
Scissor link	10	.125" thick Al extrusion 1"x1"	McMaster 88875K33
Top Scissor link	2	.125" thick Al extrusion 1"x1"	McMaster 88875K33
Bushings	40		McMaster 6338K411
Steel Pins	12		McMaster 90145A551
Trolleys	2		McMaster 9484T21
Track for Trolleys	2		McMaster 9484T711
Trolley			
Attachment	4	1/4" aluminum sheet	Pappalardo
pushnuts	24	1/4"	Pappalardo
rubber stoppers	4		Pappalardo
Steel Rod, long	1	1/2" steel rod	McMaster 90075K15
Steel Rod, short	1	1/2" steel rod	McMaster 90075K15
angle bracket	8	.125" thick aluminum angle bar	Pappalardo
piston attachment	2	.125" thick Al extrusion 3"x1"	Pappalardo
Hydraulics	1		eBay

