

# **A Flexible Infra-Architectural System for a Hybrid Shanghai**

by

Rafael Luna

B.F.A. Architecture  
Massachusetts College of Art, 2006

SUBMITTED TO THE DEPARTMENT OF ARCHITECTURE IN PARTIAL FULFILLMENT OF THE REQUIREMENTS FOR THE DEGREE OF

MASTER OF ARCHITECTURE

AT THE

MASSACHUSETTS INSTITUTE OF TECHNOLOGY

FEBRUARY 2010

©2010 Rafael Luna. All rights reserved.

The author hereby grants to MIT permission to reproduce and to distribute publicly paper and electronic copies of this thesis document in whole or in part in any medium now known or hereafter created.

**Signature of Author:** \_\_\_\_\_  
Department of Architecture , January 15, 2010

**Certified by:** \_\_\_\_\_  
**Yung Ho Chang**- Professor of Architecture and Department Head  
Thesis Supervisor

**Accepted by:** \_\_\_\_\_  
**Julian Beinart**- Professor of Architecture  
Chair of the Department Committee on Graduate Students



## **COMMITTEE**

**Yung Ho Chang, MArch**

Professor of Architecture  
Department Head

**Stanford Anderson, MArch, PhD**

Professor of History and Architecture

**Julian Beinart, BArch, MCP, MArch**

Professor of Architecture

**Mark Goulthorpe, BArch**

Associate Professor of Design



# **A Flexible Infa-Architectural System for a Hybrid Shanghai**

by

Rafael Luna

Submitted to the Department of Architecture on January 15, 2010  
in Partial Fulfillment for the requirements for the degree of Master of Architecture

## **ABSTRACT**

The increasing migration from a rural to an urban setting has led to a rapid expansion of metropolitan areas around world (50% of the world population lives in cities). The demand for living and working spaces inside the city has generated a rapid turnaround of building stock. In rapid developing cities like Shanghai, neighborhoods are replaced by higher density buildings every 30 to 40 years. Areas of extreme diversity in population and program have been replaced by high density residential towers that generate a monoculture and lose the richness of the hybrid city. Cities like Tokyo have generated self-conscious bad architecture as a result of the pressures of its high density, and increasing land value. This culture of high density has responded with new hybrid typologies that efficiently optimize real estate into a continuous flow of the city through its buildings. In order for cities to maintain a steady growth with adequate living conditions, it is important to hybridize infrastructure with building stock that generates a fluid metropolitan culture.

**Thesis Supervisor:** Yung Ho Chang

**Title:** Professor of Architecture and Department Head



## On Hybridity

The concept of a hybrid building has existed throughout history, always closely linked to density and land value. Walled cities demarcated the limits of a civilized territory and the wild. The limitations in transportation within the walls and area caused work related programs to be closely knit to residences, exemplified as the home above a shop. Stacking was a common effect generated by the physical confinements of the city. In his essay, "The Hybrid Vigor and the Art of mixing", Martin Musiatowicz links developments of mobility and defense mechanisms as one of the main cause that allowed the expansion of the city, leading it to a segregation of functions into single buildings. "City form became defined by a functionally determined planning in order to control disease, pollution, and importantly, land rates." (MUSIATOWICZ, 2008)

At the end of the 19th century and beginning of the 20th century new economic models lead by the growth in industry inside the city generated a large growing population and an emergent new social working class. (Marx) "Bourgeoisie has created enormous cities, increased urban population. Agglomerated population, centralized means of production, concentrated property in a few hands." The city's growth was in direct relation with the growth of the industry. The new relationship of industry in the city rivaled architecture as the generator of urban

fabric. Industry generated a condition of rivalry between architecture and machinery. This sets the condition for the growth of the Metropolis defined by Koolhaas as the, "simultaneous explosion of modern technologies and human population on a limited territory."

In the United States in 1985, Joseph Fenton assembled a catalogue for hybrid buildings that had been produced as a resultant of the constraints of the American urban grid with the growth of the Metropolis and established these as models for revitalizing American Cities. Although all of the hybrid buildings are multi-programmed, they differentiate with mix-use buildings by scale and form. Hybrid buildings generate a complex relation between its program, technology, urban context and society. With Fenton's definition, a hybrid building also differentiates itself from mega-structures by delimiting itself to the city grid. The vertical relation was caused by an escalating land value and horizontal restrictions. Hybrid buildings were largely developed in America at the end of the 19th century until the 1929 depression slowed all new construction plans. Shortly after, CIAM IV promoted segregation of land use, supported by the Charter of Athens, which categorized new buildings by single use. Hybrid buildings did not start again till after World War II, when a renewed interests to reinvigorate American urban cores and zoning laws were revisited.

Fenton suggested that hybrid buildings generated two categories of programming: thematic, and disparate. The thematic building generated a dependency between its parts and an interaction of elements. The disparate building had a schizophrenic, fragmented relation of parts, where pieces coexist in a mutual alliance. Thematic hybrids suggest a singleness where its

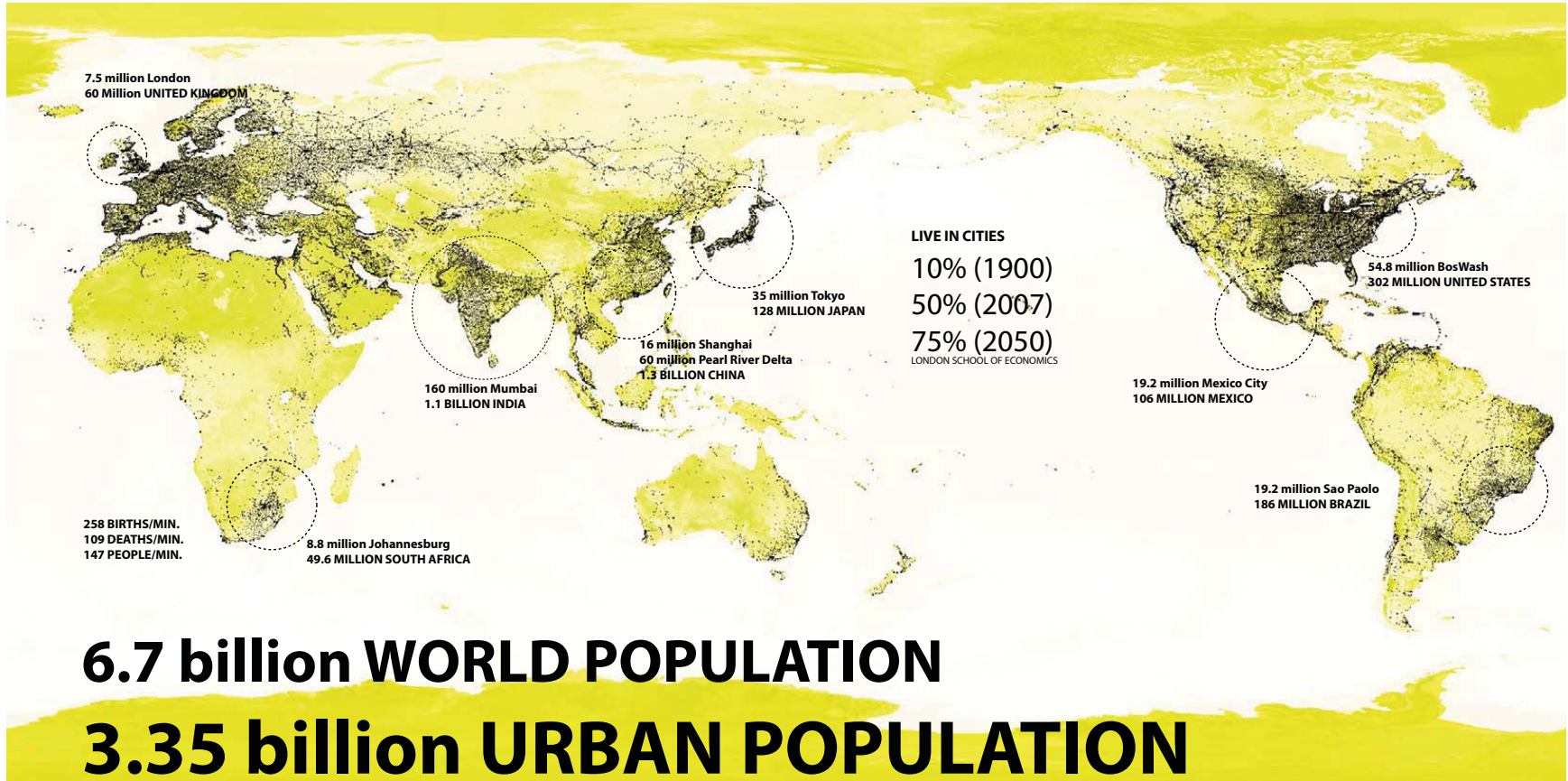

programmatic elements form a functional ensemble. Disparate hybrids promoted an economic advantage. Hybrid buildings catalogued by Fenton are also categorized into three groups based on form: Fabric, Graft, and Monolith. Fabric hybrids oppress their program under a single envelope that generates an inconspicuous overall appearance. It adheres to site conditions in order to generate urban fabric. Graft hybrids express their program on the exterior in an apparent union between building types. Monolith hybrids generally represent a section of the city within its monumental scale, accommodating the greatest diversity of functions and versatility in the city.

In his essay, "The Hybrid Vigor and the Art of mixing", Martin Musiatowicz studies Fenton's catalogue from 1985 to relate current contemporary practice, and suggests that most contemporary "hybrids" could fall under one of Fenton's categories, " however these rely heavily on retrospective classification based on the final outcome and less so on design tactics. Looking closely, there appear to be a number of broad trends which could be grouped not as categories, but more as strategies being employed (often in combination) to address heterogeneity and density." He classifies the new contemporary strategies as Monolithic and Hybrid Form, Cities within cities, Coalesced Structures, Sectional Juxtaposition and Spatial Indeterminacy, and Integrated Landscapes.

-Monolithic and hybrid forms repress functional form by separating its exterior image and structural logic from its interior programmatic composition. The monolith could be represented at a multi-scalar level.

-Cities within cities represent hybrids that merge programmatic elements from an entire city. This form of ur-

ban concentration become strategies for densification outside of city centers. they form their own urban core on the periphery in order to activate the zone.

-Coalesced Structures merge structure, aerodynamics and service core in order to service vertical hybrids. Advances in construction technology allow for this hybrid condition.

-Sectional juxtaposition and spatial indeterminacy challenges the stacking effect in vertical buildings in order to combine programs at different levels.

-Integrated landscapes questions the position a building takes as part of the public realm.

The growth in density has always been the problem and the potential for architecture in the Metropolis. In "The Metropolis and the Mental Life" Georg Simmel describes the modern life generated by the metropolitan condition as an impersonal relation of integration of activities and time schedules that generates an increasing stimulation of the nervous system that creates rushing impressions rather than the lasting sensation of the rural life. The rapidly changing and closely compressed contrasting stimulation results in the "blasé attitude." The metropolis agitates the nerves to the strongest reactivity for such a long time that it ceases to react at all. Bodily proximity and narrowness of space make the mental distance more apparent.

Koolhaas, fascinated by this condition in New York, explores the possibilities that density has to offer in the architecture of mixing. In "Life in the Metropolis" or "The Culture of Congestion," Koolhaas studies specific examples in new York that lead to architectural concepts that exploit conditions of congestion to generate new forms

CITY

POPULATION

Mumbai, India

13,922,125 (Municipal Corporation)

**SHANGHAI, China**

**13,481,600 (Core Districts and Inner Suburbs)**

Karachi, Pakistan  
Istambul, Turkey  
Delhi, India  
Sao Paulo, Brazil  
Moscow, Russia  
Seoul, South Korea  
Beijing, China  
Mexico City, Mexico

12,991,000 (City Districts)  
11,372,613 (Municipality)  
11,325,124 (Municipal Corporation)  
10,990,249 (Municipality)  
10,452,000 (City Proper)  
10,421,782 (Special City)  
10,123,000 (Core Districts and Inner Suburbs)  
8,836,045 (Federal District)

**TOKYO, Japan**

**8,731,000 (23 Special Wards Area)**

Jakarta, Indonesia  
New York City, USA  
Lagos, Nigeria  
Kinshasa, Congo  
Tehran, Iran

8,489,910 (Special Capital District)  
8,274,527 (City Proper)  
7,937,932 (Statistical Area)  
7,843,000 (City-Province)  
7,797,520 (City porper)

**LONDON, UK**

**7,683,316 (Greater London)**

Lima, Peru  
Bogota, Colombia  
Hong Kong, China SAR

7,605,742 (Province)  
7,155,052 (Capital District)  
6,985,200 (Special Administrative region)

CITY

DENSITY people/sqkm

**SHANGHAI, China**

**6,992 (Core Districts and Inner Suburbs)**

**TOKYO, Japan**

**14,151 (23 Special Wards Area)**

**LONDON, UK**

**4,863 (Greater London)**

[http://en.wikipedia.org/wiki/List\\_of\\_cities\\_by\\_population#cite\\_note-WG-0](http://en.wikipedia.org/wiki/List_of_cities_by_population#cite_note-WG-0)

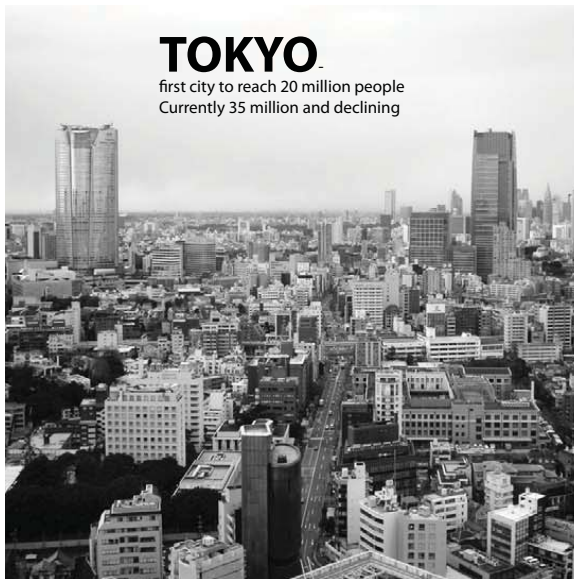

**TOKYO**

first city to reach 20 million people  
Currently 35 million and declining



**SHANGHAI**

largest city in China  
Currently 16 million registered plus about 3 million floating  
Increasing

Peak 96,200 people/ sqkm  
Central Area 24,673 people/sqkm



**LONDON**

first city to reach 1 million people 1820's  
Currently 8 million and stable

of social interaction. "The Metropolis annuls previous history of Architecture, it generates its own urbanism, and architecture that originate from the splendor and misery of the metropolitan condition." Manhattan became a quintessential example of the metropolitan condition. Its growth was possible by technology that rivaled and surpassed natural production for sustaining life. In his essay, Koolhaas deduces conclusions in reference to Manhattan and the Metropolitan condition that denote a symbiosis between hybridity and the Metropolis.

Conclusion 1: The Metropolis is irrevocably the resultant of such identifiable mental constructions, and that is the source of its fundamental "otherness" from all previous Urbanisms.

Conclusion 2: Through the medium of the skyscraper, each site in the Metropolis accommodates- in theory at least- an unstable and unforeseeable combination of superimposed and simultaneous activities whose configuration is beyond the control of architect or planner... Exterior and interiors of such structures belong to two different kinds of architectures.

In response to conclusion 1: (Technology) This conclusion makes references at the use of technology that was created in order to support life in the metropolis in ways that surpass nature. Electricity facilitated night-life, and activated the city day long. The production of milk from the "milk machine" allowed for a consumption of milk larger than what cows could produce. Based on the research of "The Endless City," migration into urban environments has not ceased, and the Metropolis has to sustain a current influx of migrants, which cause an inevitable growth of the city into a Mega-Metropolis.

Constantinos Doxiades in his studies of ekistics suggested a continuous growth of urbanization which caused a Megalopolis. Architecture would then need to act at a regional scale in these conditions. Architecture can be implemented as systems for new technologies, machines for energy production, food production, and management of resources, juxtaposed to urban program in order to act as typologies that could be implemented at city scale as well as regional scales. These combinations would facilitate the growth of the metropolis and living conditions. Decentralizing the industrial city into polycentric production facilities inside the city would generate new architectural typologies and ways of life. In Chapter 1 of "Managing Fast Growing Cities", Nick Devas and Carole Rakodi make the case that urban growth is also caused not only by a continuous migration from rural to urban, but also by an increasing population growth from within the city. The result is an increasing poverty level and subserviced areas. As cities and urban center continue to grow, infrastructure becomes a greater demand. "The failure to expand water supplies, sanitation systems, housing supply and transportation to match the growth of population has been a prime cause of misery in the cities of the developing world." (Devas, Rakodi)

Developed nations like Japan have evolved with the culture of congestion into a growing field of hybrids that allow for the growth and development of the city. Atelier Bow Wow produced a catalogue, similar to Fenton's catalogue of American hybrids, where they classify what they call "No-good architecture." These are buildings that are "self-conscious", "posses a stubborn honesty to their surroundings and programmatic requirements, without insisting on architectural aesthetics and

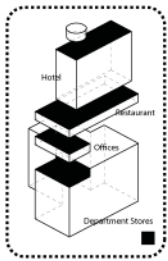

TERRACE PLAZA

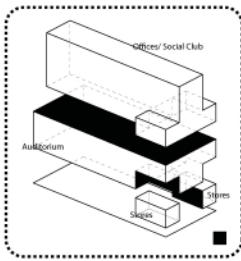

SCHILLER BUILDING

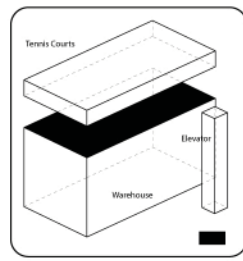

WAREHOUSE COURTS

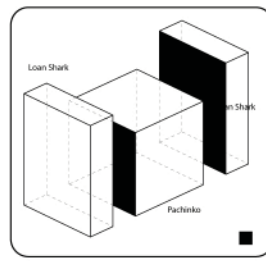

PACHINKO CATHEDRAL

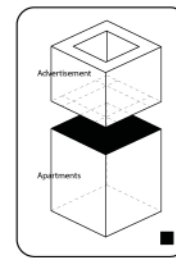

BILLBOARD APARTMENT HOUSE

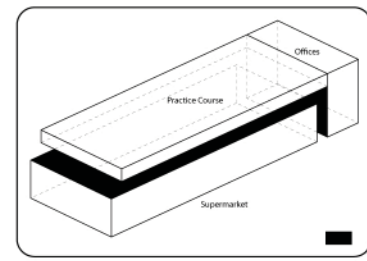

SUPER CAR SCHOOL

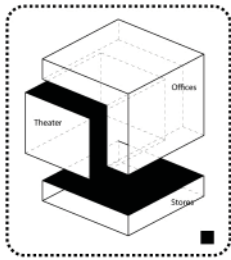

STUART BUILDING

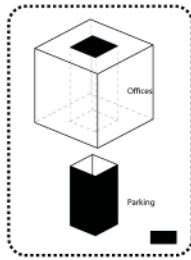

PURE OIL BUILDING

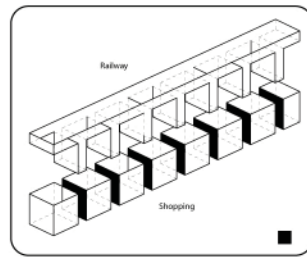

ELECTRIC PASSAGE

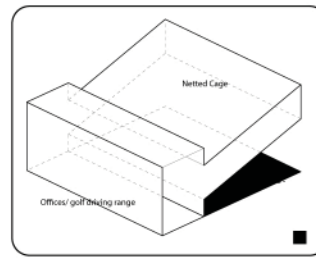

GOLF TAXI BUILDING

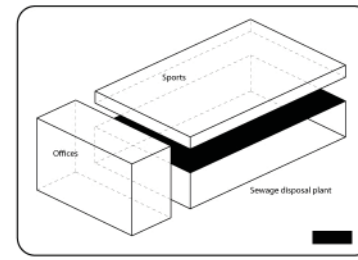

SEWEGE COURTS

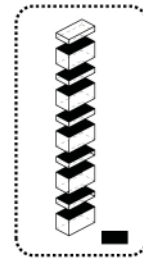

100 STOREYS BUILDING

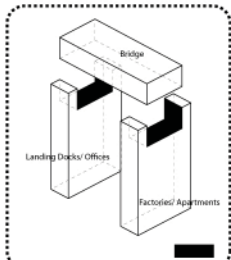

SAN FRANCISCO BAY BRIDGE

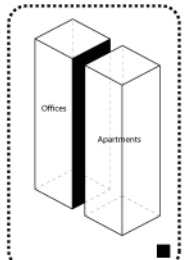

H.C. PRICE COMPANY TOWER

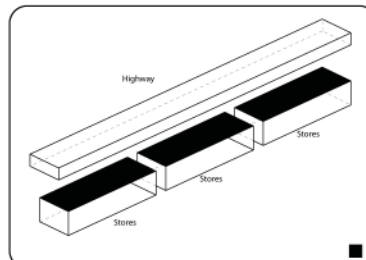

HIGHWAY DEPARTMENT STORE

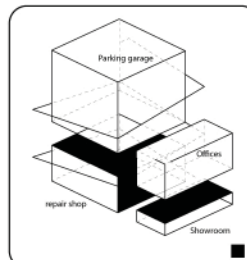

CAR TOWER

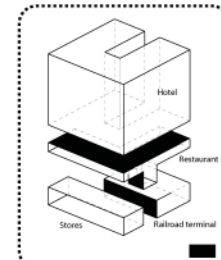

BILTMORE HOTEL

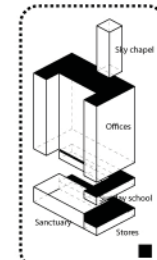

CHICAGO TEMPLE

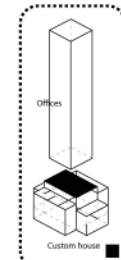

CUSTOM HOUSE

### Diagrams of Programmatic Hybrids:

Reinterpretation of diagrams from Joseph Fenton's and Atelier Bow Wow's Catalogues.

In both catalogues, the hybrid relation is a programmatic one that hints at a particular way of life.

# POPULATION AND DENSITY OF SHANGHAI

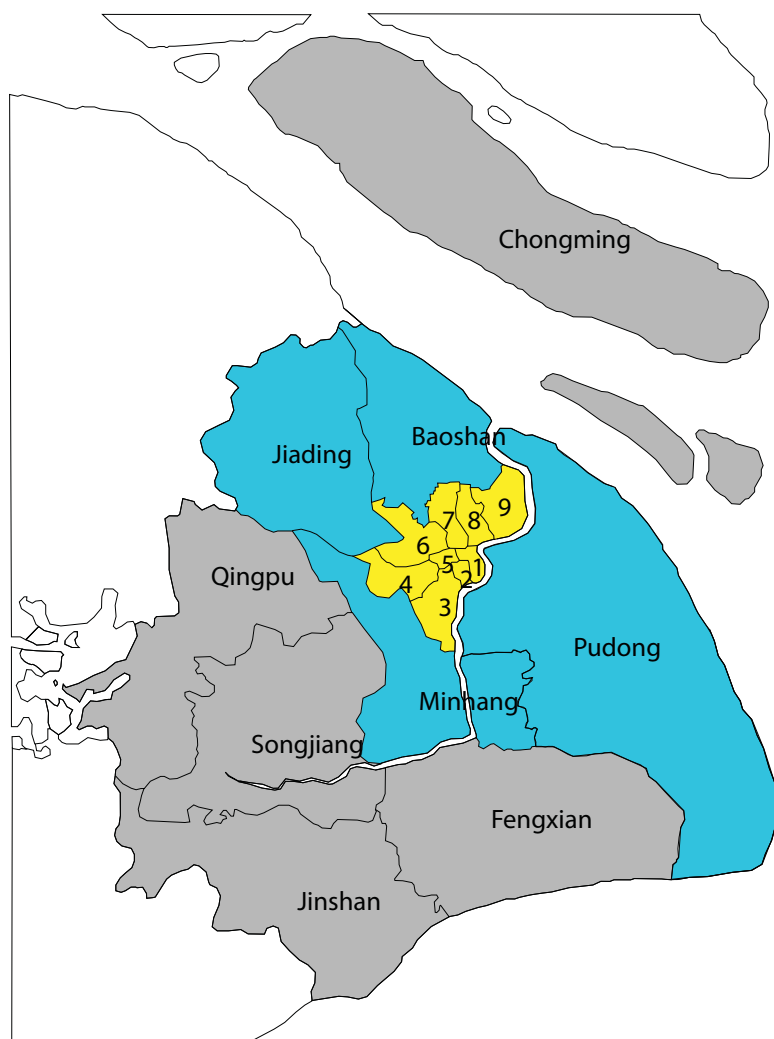

District Population	(2000 census)	Area (km <sup>2</sup> )	Density (/km <sup>2</sup> )
1. Huangpu District	574,500	12.41	46,293
2. Luwan District	328,900	8.02	41,010
3. Xuhui District	1,064,600	54.76	19,441
4. Changning District	702,200	38.30	18,334
5. Jing'an District	305,400	7.62	40,079
6. Putuo District	1,051,700	54.83	19,181
7. Zhabei District	798,600	29.26	27,293
8. Hongkou District	860,700	23.48	36,657
9. Yangpu District	1,243,800	60.73	20,481
Shanghai proper	6,930,400	281.54	24,616

Inner Suburbs:			
District Population	(2000 census)	Area (km <sup>2</sup> )	Density (/km <sup>2</sup> )
10. Pudong New Area	3,187,400	1210.41	2,633
11. Baoshan District	1,228,000	415.27	2,957
12. Minhang District	1,217,300	371.68	3,275
13. Jiading District	753,100	458.80	1,641
Inner suburbs	6,385,800	2,456.16	2,600

Outer Suburbs:			
District Population	(2000 census)	Area (km <sup>2</sup> )	Density (/km <sup>2</sup> )
Jinshan District	580,400	586.05	990
Songjiang District	641,100	604.71	1,060
Qingpu District	595,900	675.54	882
Fengxian District	624,300	687.39	908
Outer suburbs	2,441,700	2,553.69	956

The Islands:			
District Population	(2000 census)	Area (km <sup>2</sup> )	Density (/km <sup>2</sup> )
Chongming County	649,800	1,041.21	624

Central Area 24,673 people/sqkm  
Administrative boundary 2,590 people/ sqkm

Peak **96,200** people sqkm

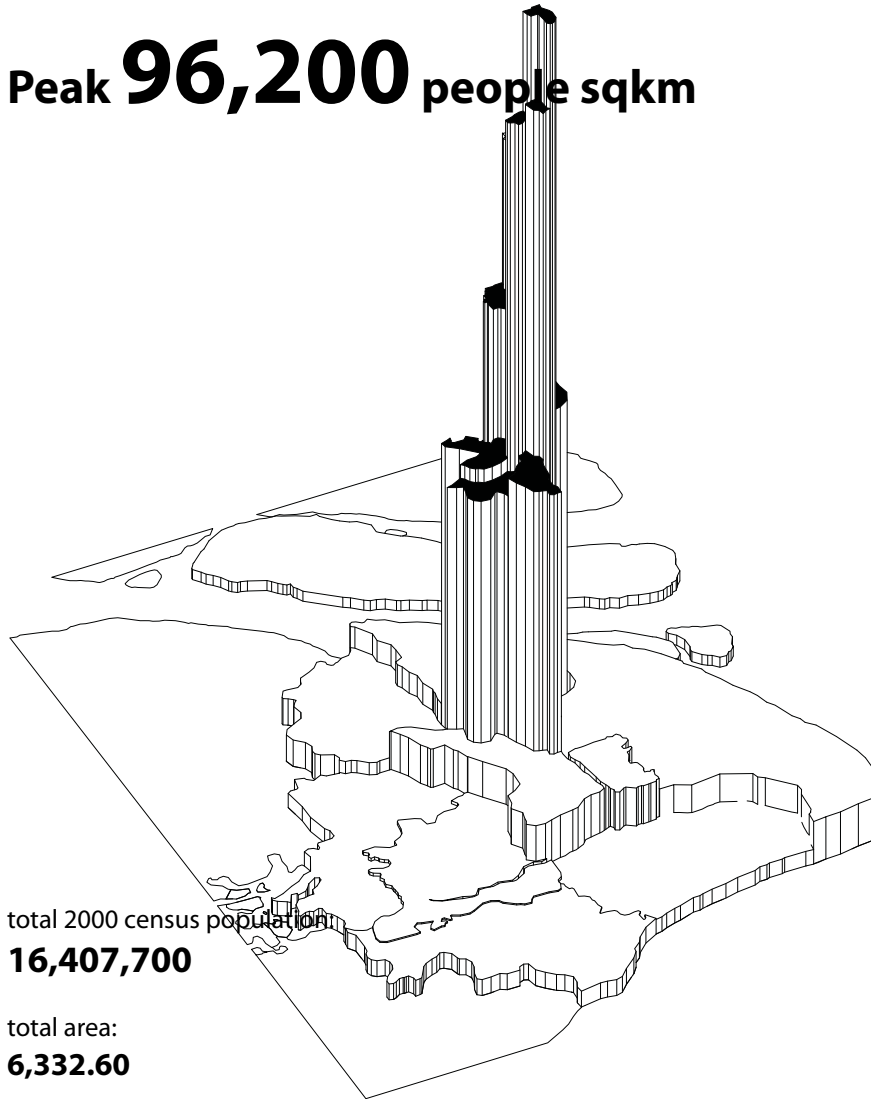

form." Just how Fenton suggested that hybrids represent a barometer that records the evolution of society, Tokyo's "No-good" architecture are a concrete reporting of Tokyo's Metropolitan condition.

Tokyo has evolved differently from European cities in the sense that their building stock is replaced every 30 to 40 years using the contemporary technology of the time. European cities have the culture of recycling their building stock, which slows the ability to generate new metropolitan conditions. The use of contemporary building technology has generated, "shameless spatial compositions and functional combinations unthinkable in the European city." "No-good" architecture has formed the urban fabric of Tokyo by creating coherent environments within the city. These buildings are defined as hybrids where unrelated functions coexist under a single structure, there is a joint utilization of several different and adjacent buildings and structures, and they condense unusual urban ecologies in a single building. Some of these buildings cross-categorize between architecture, urban, civil, and landscape. Infrastructure like highways, train stations, ventilation ducts, perform a greater cultural role than just infrastructure. Some of the expressways are infilled underneath with extra program like retail, offices, and housing. the pressure of land value and density has forced additional program into any empty void and urban gap. there is an urban connectivity between the systems of transportation and buildings, so that the city works in a continuous metropolitan flow.

In response to conclusion 2: (Verticalism). With the influence of Fordism shaping corporate architecture, the skyscraper became an icon of labor organization during modernism. " Modern architects thought of the

skyscraper as associated with the organization of work, with the office. In fact, the prototypic skyscraper of modernity is the expression of such organization; a optimized arrangement for archiving and connecting workers that archive and connect data.” (Abalos, 2008) The Seagram’s building in New York defined the skyscraper as the corporate vehicle. Without any monumentality, the skyscraper became a reflection of density and monoculture in the metropolis. Koolhaas saw the skyscraper as a social condenser; a tool for hybridity. The skyscraper is an accumulation of privacies where each floor is independent of another and could represent a different scenario. The Downtown Athletic Club shows a collage of functions in each plan. the 100-Story Building has 1/3 industry, 1/3 business, 1/3 residential with a public floor every 20 floors. The skyscraper substitutes any bi-dimensional urban planning into vertical components of the city grid, which incorporates elements of the public realm into a private sector, making the skyscraper more of a component of organization for the city.

#### HYBRID expansion of the city:

The pressure of the growing city, in combination with program and architecture form warp a pure building into an anti-typology where functions are mixed, disparate uses combined, and structures collected into a Hybrid building. Steven Holl suggests that hybrid buildings are not caused by the pressures of density and the metropolitan condition, but as a response to the dispersion and frequency of deformed towns. Free standing corporate headquarters, industrial parks, shopping centers, malls, and suburban housing scattered through the countryside have dissipated town centers that strongly

need revitalization. Hybrid buildings are physical architectural forms that concentrate activity to invigorate urban life. The hybrid building is manifested as an individual form that supports the underlying pattern of the city grid in order to clarify Urban vs. Rural. Its architecture should be understood in terms of its programmatic diversion that reinstate the diversion of activity and essential components of city life.

In the Sociopolis Project by Vicente Guallart for the city of the future, the expansion of Valencia is investigated as a prototype for other European cities. Guallart calls it the ruburban project, a hybrid expansion that defines the condition between Urban and Rural. Instead of the city grid expanding like Cerda’s plan in Barcelona, the Huerta (farm land) becomes the defining component for parceling the site. Each parcel represents a different crop, connected by a pedestrian running track. A matrix of the program of the city is divided into the different parcels which are then developed by different architects. This continuous combination between program and farming site creates a variety of hybrid buildings that respond to components of urban and social equipment, services, work, infrastructure, and private property. Sociopolis proposes a cohesion between a new urban culture generated by the hybridity of the site and its building components.

#### HOUSING and density:

Housing stock composes the majority of city fabric in most cities. As density increases, the housing supply becomes a major issue for the expansion of the city. At the end of the 19th century, the increasing growth of the proletariat created the need for new housing.



**WORLD FINANCIAL CENTER 492m**  
 2008 World Tallest Tower Completed  
 Architect: KPF

**JIN MAO BUILDING 421m**  
 1999 World Tallest Tower  
 Architect: SOM

## SHANGHAI Buildings Over 8 Storeys

- 8 to 10 Storeys
- 11 to 15 Storeys
- 16 to 19 Storeys
- 20 to 29 Storeys
- 30 and over

**121**  
TOTAL BUILDINGS  
**1,270,000sqm**  
CONSTRUCTED

78 33 7 3 0



1980

**748**  
TOTAL BUILDINGS  
**9,140,000sqm**  
CONSTRUCTED

207 244 145 137 15



1990

**10,045**  
TOTAL BUILDINGS  
**131,000,000sqm**  
CONSTRUCTED

**3,529**  
TOTAL BUILDINGS  
**61,800,000sqm**  
CONSTRUCTED

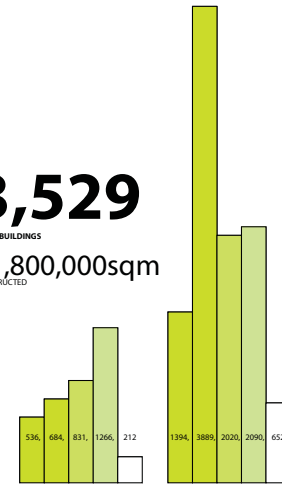

2000

2005

**65 MILLION SQM** OF CONSTRUCTION IN 2006

**AREA IN SHANGHAI**  
 6,340,000,000sqm

Karel Tiege addressed the housing crisis by looking at the minimum dwelling. The minimum dwelling is the “central problem of modern architecture and the battle cry of today’s architectural avant-garde.” The housing crisis demanded for small size units at a low cost and Tiege suggests the International Modern Architecture for the minimum dwelling so that the somber and sterile architecture became just another machine in the city that lacked culture and tradition. The new architecture should be developed based on statistics and data to address patterns in the population and function. The merger between statistics and technology should formulate an architectural solution that addresses social needs with a rationalized mass production. Bruno Taut and Walter Gropius explored the minimum dwelling as a family condenser that hybridized functions within the same household. Kitchen and bathroom could be united as a wet room. The family living room was also used as the bedroom for the children with the rational that living rooms are only in use when the parents are awake. Once the head of the family goes to sleep, so does the rest of the family and the living room no longer has a purpose. Hybridity occurred by an optimization of function by time. A single space can be used for different functions based on the time of occupancy. Current demographics demand for a different type of housing stock. In fast growing cities, there is a continuous flow of a floating population of immigrants and commuters. Also, there is a growing older population that is breaking the family unit. Shanghai has an average family unit of 2.8 members. Housing demands an increasing flexibility. In “Specific Neutrality, A manifesto for new collective housing”, Atelier Kempe Thill suggest the current demand for flexibility from the housing unit, developer, and construction method. It implies that the future housing stock should have a certain neutrality of

use that allows for the flexibility and adaptability of the building. By constructing these neutral settings, new hybrid possibilities are created where housing stock could also be offices, retail, and so forth, promoting a metropolitan condition inside the building.

There is a need for a certain autonomy in new construction of hybridity in order to maintain the growth of a fast developing city while maintaining a metropolitan environment or poly-culture. Housing stock as well as infrastructure are the major components for growth with could be hybridized under one building to generate the metropolitan setting, with a certain autonomy of typology, and allowing for diversity in use for multiple programs under one structure.

Bernard Tschumi explores the autonomy of architecture in Parc de la Villette as a setting for hybridity between diverse programs in a horizontal setting. Schizophrenic places, words, and things on the same plane without distinguishing their respective origins generate a hybrid sense of place with no specific typological connotation. A combination of multi-referential anchoring points re-groups fragments independent of their past. A single architectural form no longer implies a single function but a setting for diverse variations. He achieves this architecturally by modes of cross-programming where typologies are displaced, and trans-programming where programs can be combined. Combinations and permutations amongst different categories of analysis, not composition or expression of function, generate new programmatic relations creating event spaces for hybridity.

If there is a possible hybrid condition between infrastructure and housing, as learned from the Tokyo examples of Atelier Bow Wow, we could rethink Martin Musiatowicz's category of coalesced structures, as a possible strategy for designing these settings. Infrastructure could be designed with building service cores as structure. This would allow for the utilization of these structures as infrastructures of transportation, resource management facilities, energy production, food production, in collaboration with urban programs, housing, offices, retail, parking, etc. to generate new hybrid typologies. The hybrid condition occurs not by directly juxtaposing the layouts for different programs, but by allowing the building to serve as a setting for metropolitan events and providing the infrastructure necessary for it.

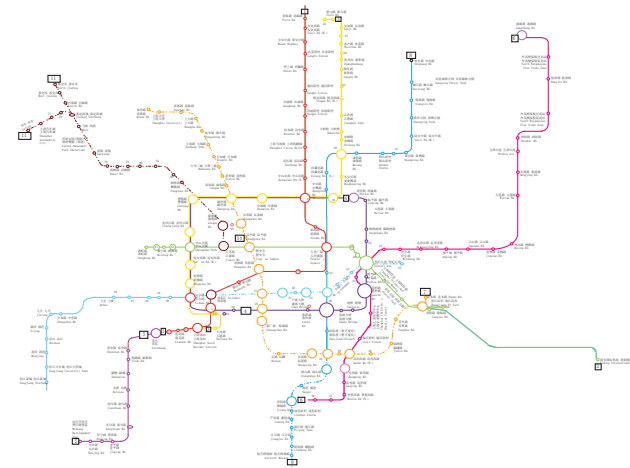

Current Subway System

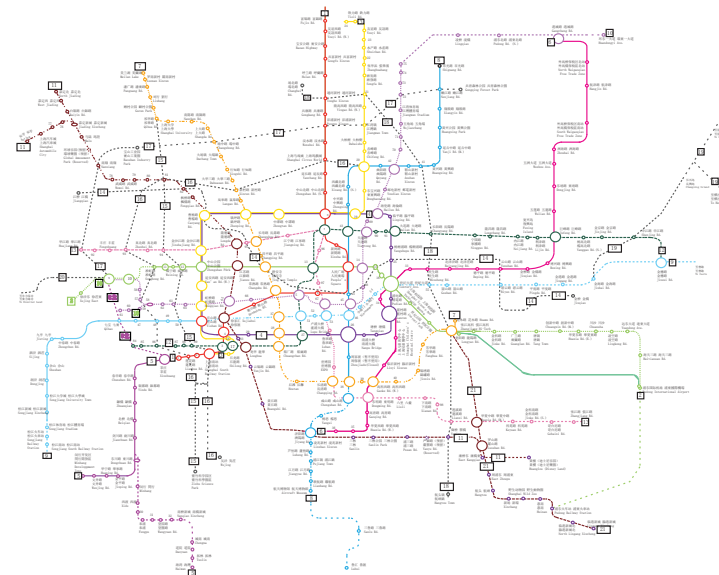

Base file from: [http://en.wikipedia.org/wiki/File:Shanghaimetro\\_2020.svg](http://en.wikipedia.org/wiki/File:Shanghaimetro_2020.svg)

Proposed Expansion



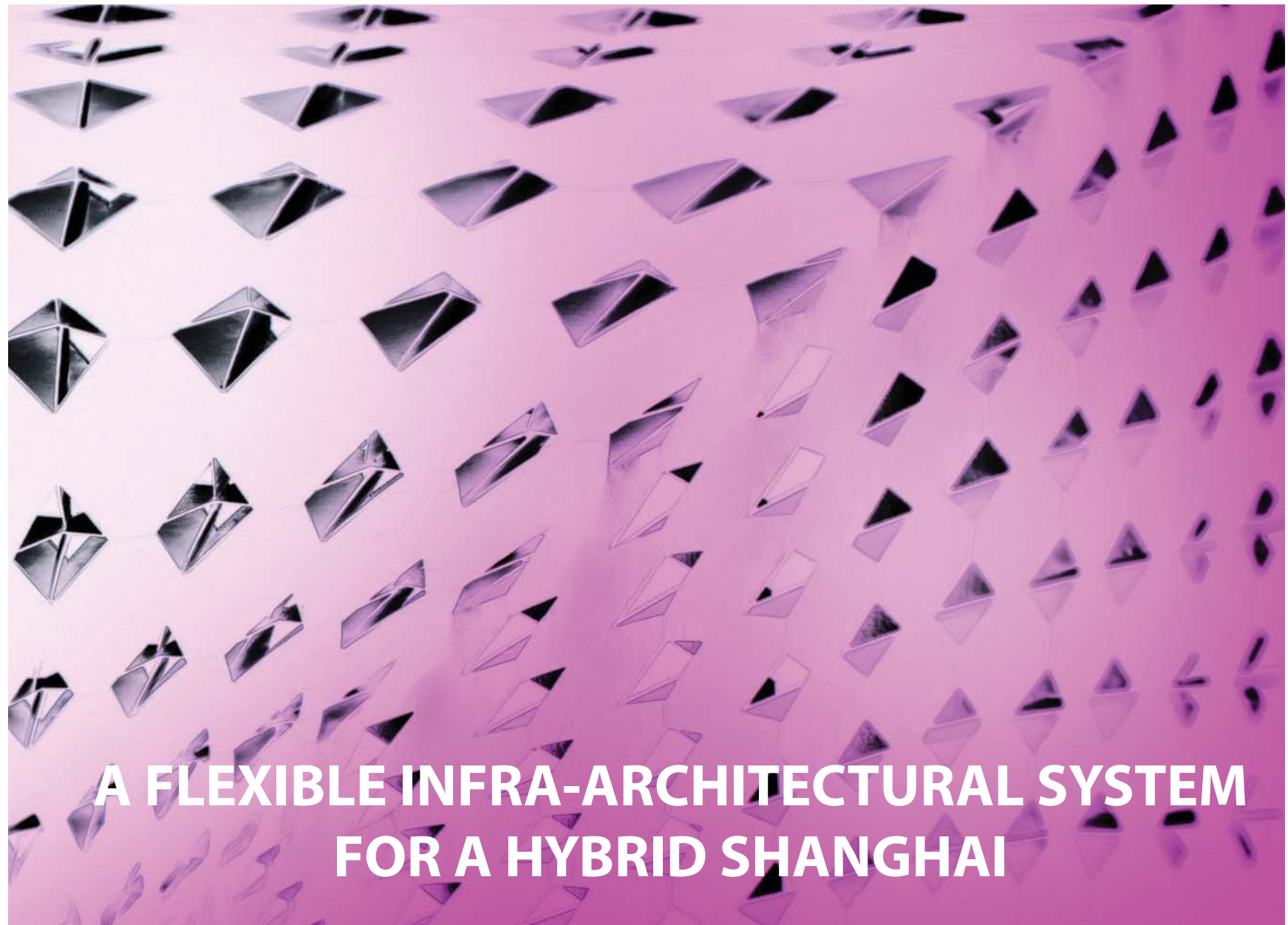

**A FLEXIBLE INFRA-ARCHITECTURAL SYSTEM  
FOR A HYBRID SHANGHAI**

# A FLEXIBLE INFRA-ARCHITECTURAL SYSTEM FOR A HYBRID SHANGHAI

Metropolitan architecture has followed a lineage that started at the beginning of the 20th century and has generated four concepts: the reuse of the city's infrastructure, verticalism, hybrids, and autonomous settings.

The population increase in Shanghai has generated a high density within the city's inner ring. This effect produces high congestion within the city and a high demand for housing. One of the most important infrastructure work that is been done right now is the development of the world's largest subway system. Even though this is an underground network, its stations are in direct relation to the cities fabric and can become a influential factor in the development of the neighboring blocks. In this case, the doubling of the subway system has the potential of providing much needed building stock.

The City of Shanghai is proposing to double its subway system by the end of 2010 and more than triple it by 2020. This generates an underlying structure and fabric within the city. The diagram on the right show the network of a single new subway line.



**More than 21 million by 2010**  
13.78 million registered under the hukuo system

Estimated 18.58 million  
**6.6 million floating population**  
**35% floating**

6.27 million spent at least one month  
4.67 million spent at least 6 months

LABOR AND BUSINESS 66%  
TOURISM 23%  
Tourist Floating Population- 2.79 ml people visited during spring festival



Base Aerial Photograph from Google Earth

## **SUBWAY LINE AS A SINGLE VERTICAL BUILDING**

### Proposal for Line 10:

A single subway line can be compared to a skyscraper, where each stop represents a level and the train becomes analogous to an elevator. Each stop in the city has its very characteristic program based on its surrounding neighborhood. In this case, line 10 on the subway systems passes through two major universities, a national stadium, a national library, national zoo, tourist destinations, and transportation hubs (airport and railway station) that connect Shanghai to other cities and the rest of the world.

Some of these stations can relate to one another and their programs can interconnect with the use of the subway. Universities can share resources of the National Library, tourists can arrive at the airport or railway station and be directly linked to attractions and hotels.

The inter connectivity of programs creates a mixture of distinct typologies that can be analyzed as a graft hybrid building with stack programming.

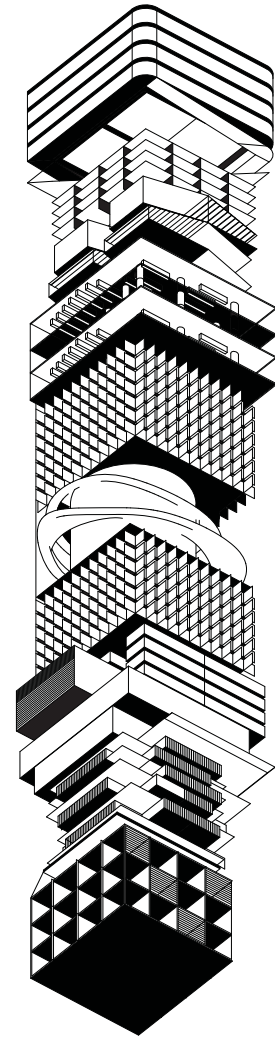
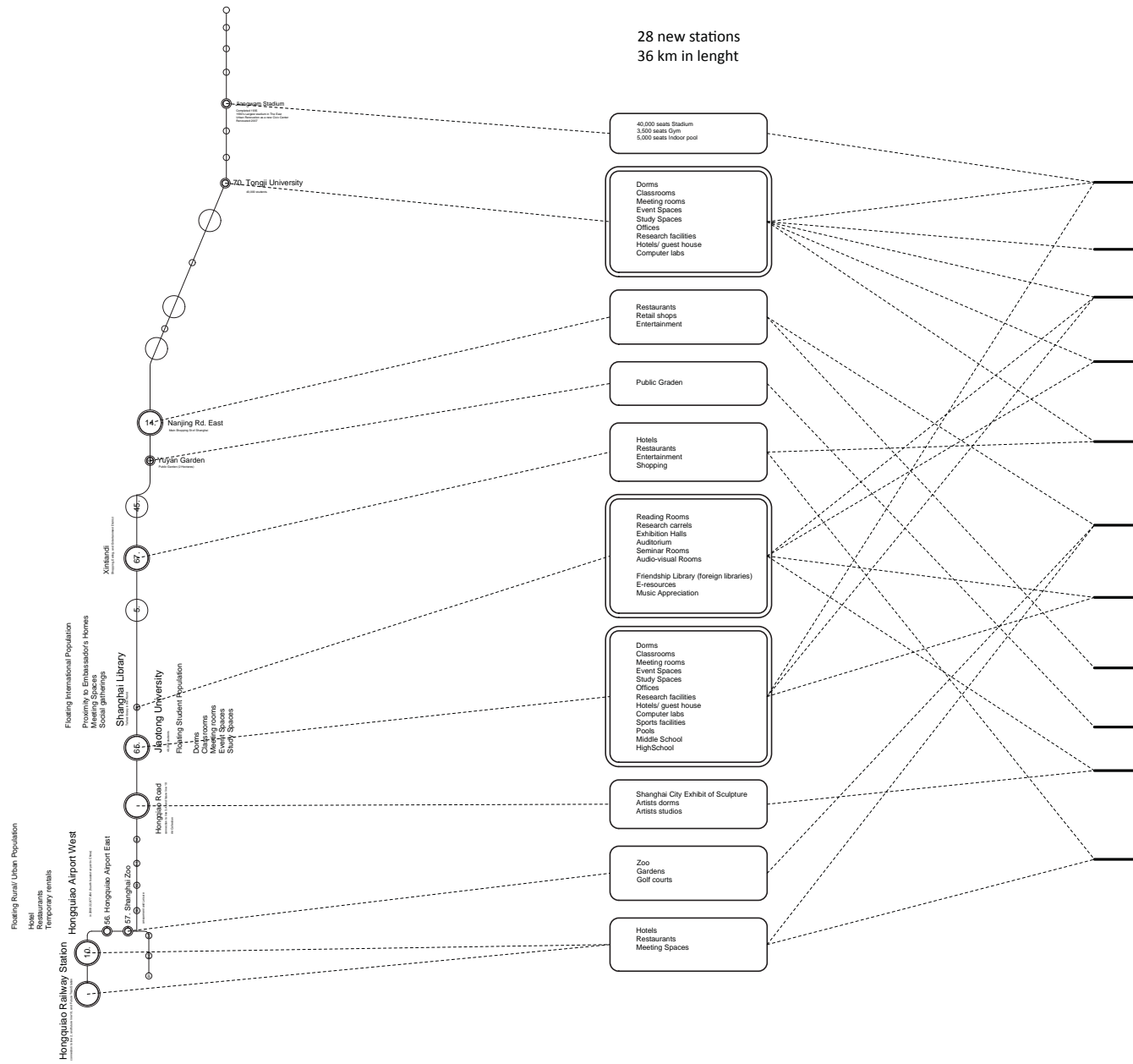

## **FROM GRAFT PROGRAMMATIC HYBRID TO FLEXIBLE INFRASTRUCTURE**

The programmatic relations of a graft hybrid building are all visible in the architecture. The grafting occurs from known typological elements with distinct known program. The growth of the metropolis is unpredictable and the idea of grafting together programmatic elements in order to produce hybridity becomes obsolete. In order to design for the unpredictable it is necessary to shift from directly programming a building to the study of a flexible infrastructure that accommodates the possibility of multiple functions within the building.

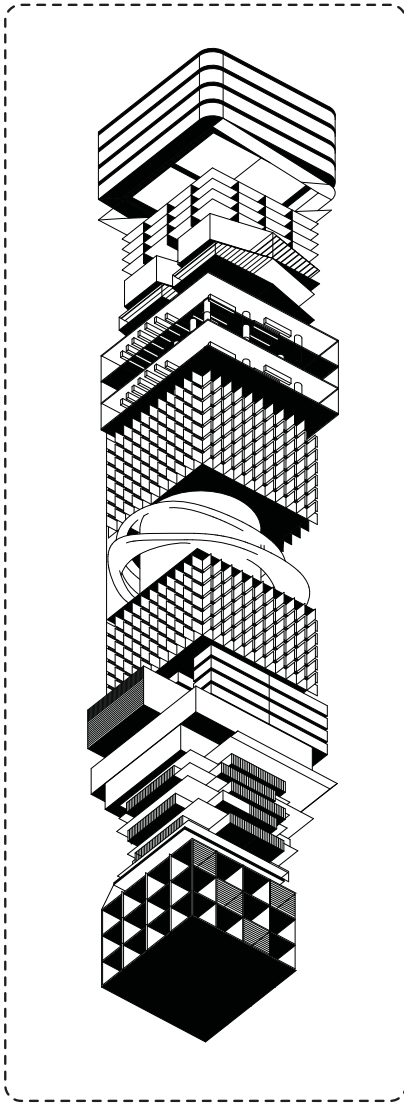

**Graft hybrids** express their program on the exterior in an apparent union between building types.

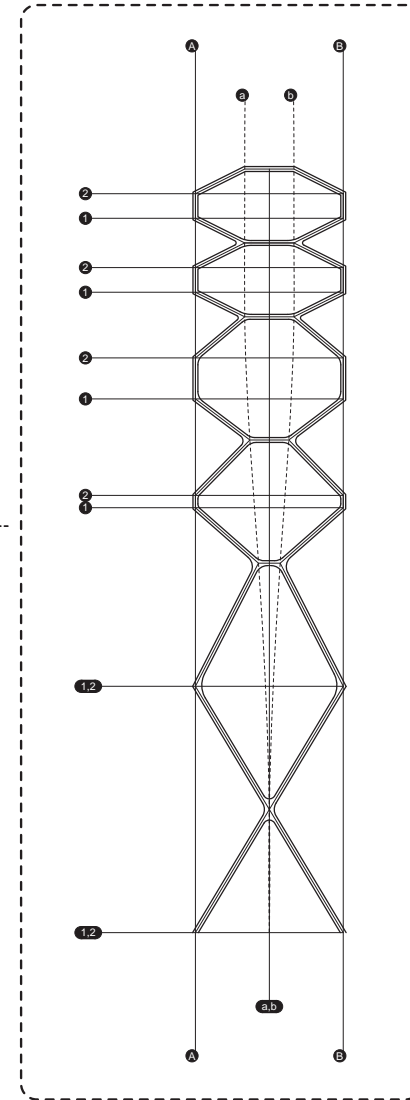

**Flexible Infrastructure** merge structure, and services to allow for different environments.

## DENSITY BY COMPACTNESS



Shanghai's population is currently growing at a faster speed than its building stock. The need for new housing and infrastructure has developed a flat slab typology that runs east to west. This building stock is generating an urban fabric that lack the hybridity it once had. New housing is been developed as gated block that ignore the street life, and do not offer any other metropolitan program inside the block.

## Typical Apartment -80 sqm

2 Bedrooms  
2 WC  
Living Room

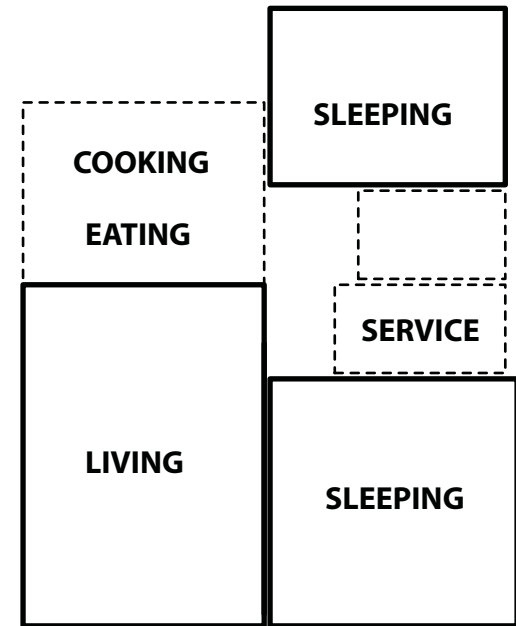
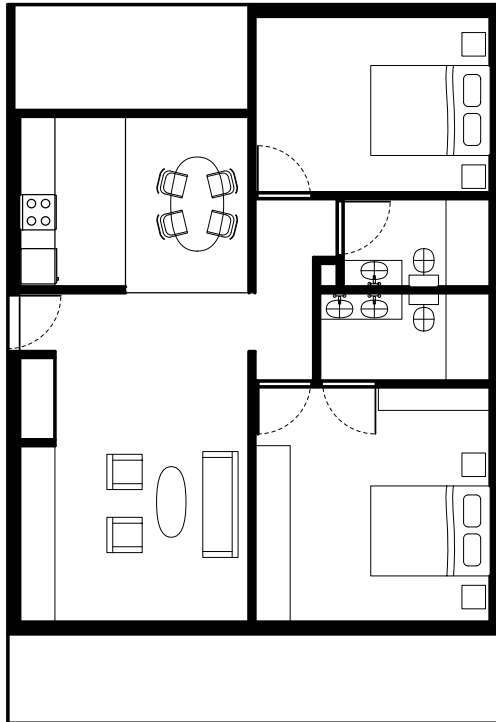

Components of Typical Apartment-

## From 80 sqm family unit to a 22 sqm Single Unit

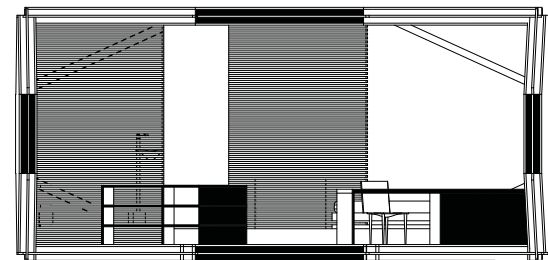
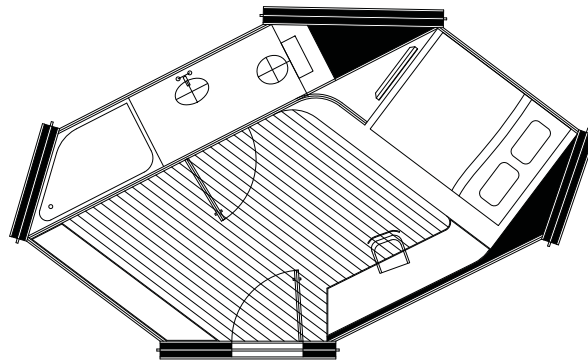

## INFRASTRUCTURE AS PUBLIC REALM

Infrastructure plays a larger role in the city's fabric than just a hidden framework. The current growth of Shanghai is altering the hybrid condition at street level. Large housing blocks segregate the street from the housing with a walled periphery. Subway stations can be developed addressing the housing density and breaking the block to allow for larger public spaces with services and amenities.

**East to West Gated Block-** Infrastructure is built as a separate entity. The block remains closed with no possible hybrid condition.

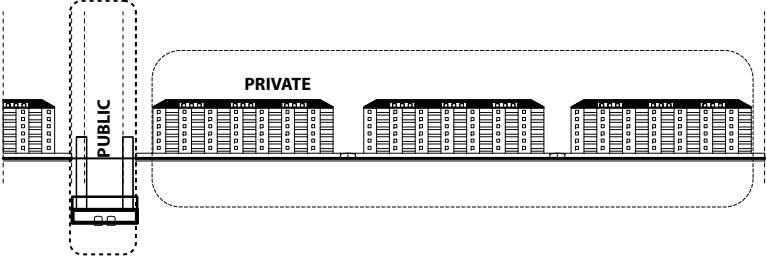

**Open Block Elevated Housing-** By elevating the housing units the block can be opened to the public, making use of the infrastructure to allow for additional program and amenities within the block.

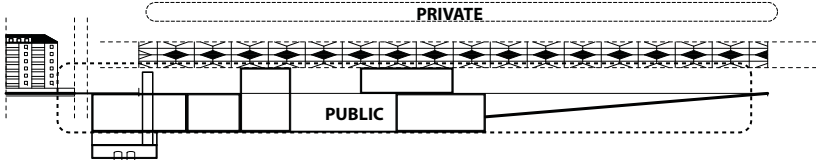

**Low Rise High Density**

**East to West Pattern**

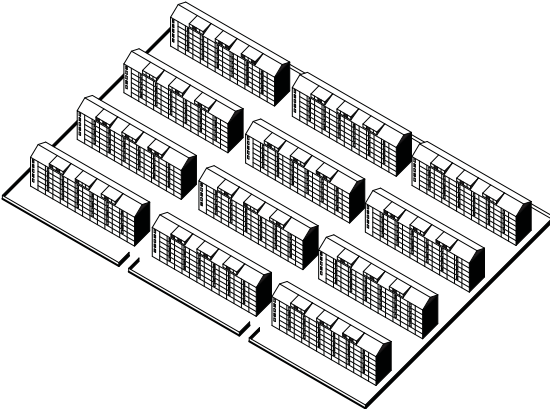

324 Apt  
6 Storey Buildings

**Mega-Block**

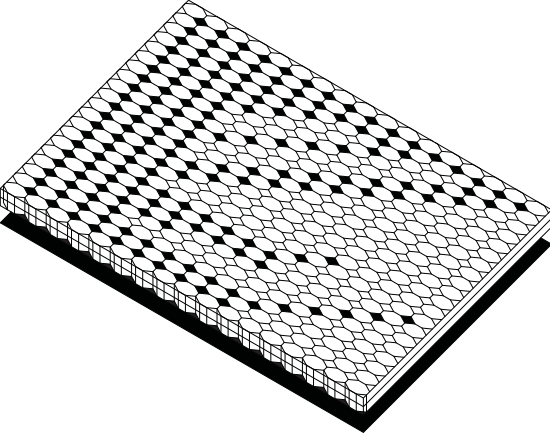

340 Apt  
2 Storey Single Deep Block Building

## MEGA-BLOCK STUDIES

**East to West Pattern-** In order to maintain southern exposure on all units large voids need to be created. This produces the need for additional circulation area, single views, and less interaction.

**Chamfered Coffer-** This configurations allows for less circulation, multiple views from a single unit and more additional units with the same area.

**20 Units**

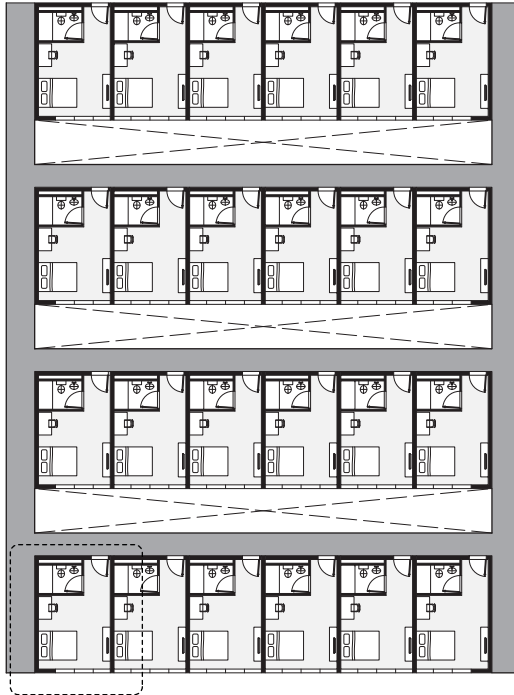

40 Units in 2 Floors  
5 Corridors  
1 View per Unit  
Mechanical Ventilation for toilets

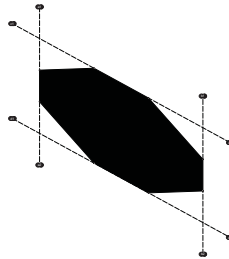
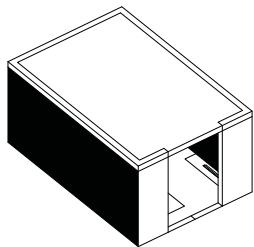
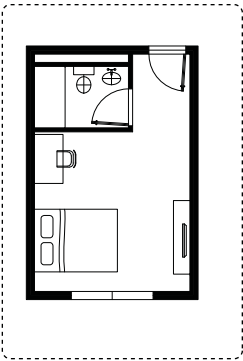

**30 Units**

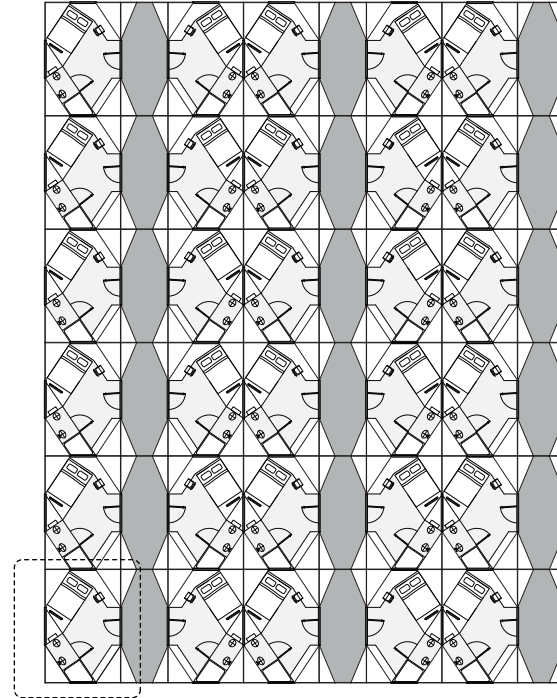

60 Units in 2 Floors  
3 Corridors  
4 Views per Unit  
Natural Ventilation for toilets

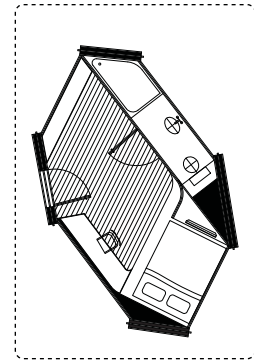
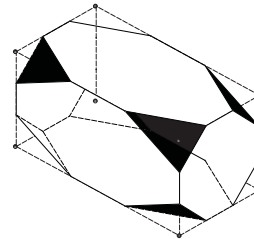

## GRAFTING OF TWO SYSTEMS- Housing and Subway

Non-standard serial modularity allows for the customization of mass production, addressing the rapid expansion of highly dense cities. This modularity strips away any historical and architectural reference allowing for an autonomous setting to occur within a single building generating a new breed of metropolitan architecture. Hybridity shifts from programmatic to infrastructural flexibility. How can this flexibility be generated with new infrastructure for a growing city like Shanghai's fast growing subway system in order to create urban nodes of hybridity?

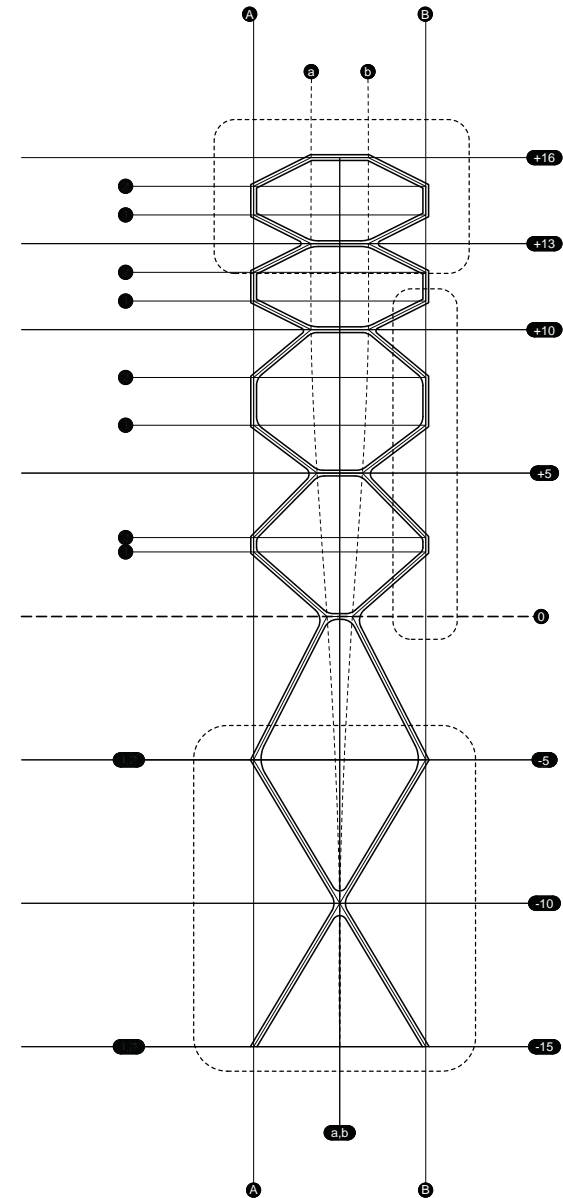

**HOUSING-** Structural Pod

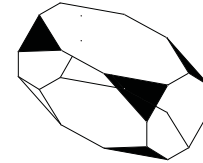

**INFRASTRUCTURAL FACADE**

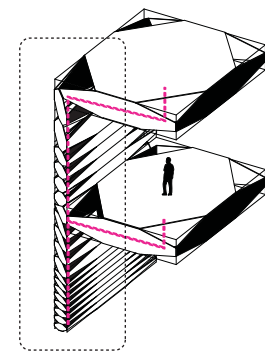

**INFRASTRUCTURAL SLAB AND CORE**

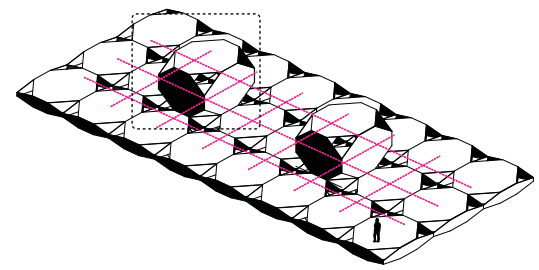

**SUBWAY-** Vertical Circulation

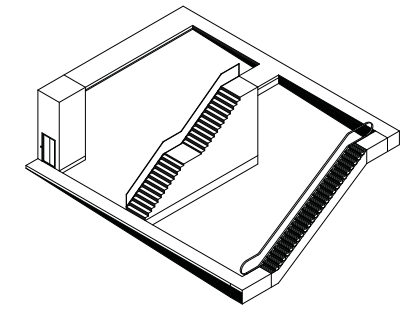

## DEGRADATION OF PROGRAM-

The grafting of both systems displaces program throughout the infrastructure. Housing is decomposed to the minimum needed. Components such as kitchens are replaced by food retailers, restaurants, kiosks, that address a new urban nomad lifestyle.

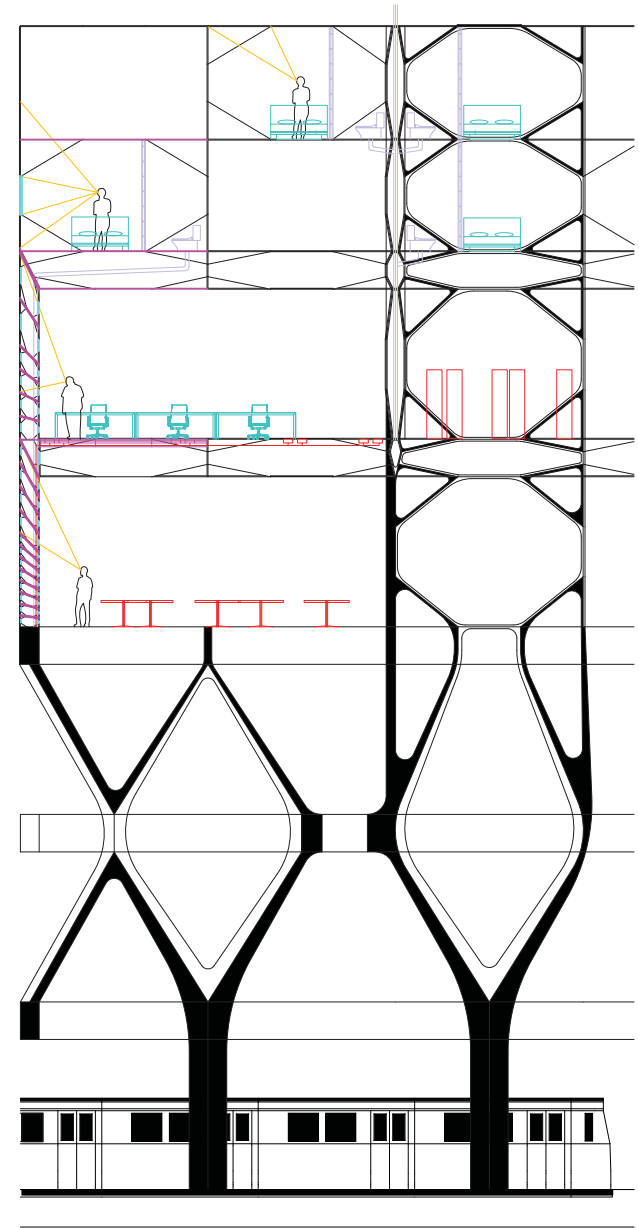

## HOUSING- Structural Pod

### Single Living Unit

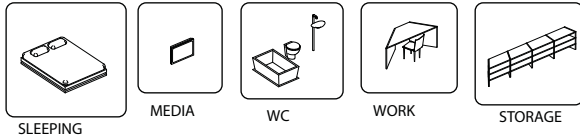

## SUBWAY- Vertical Circulation

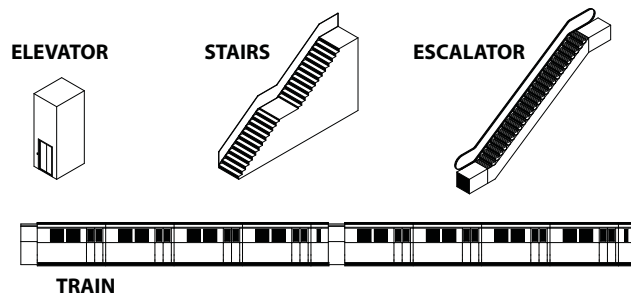

## THIRD SPACE- Transitional Program

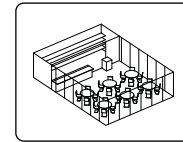

**EATING BOX-**  
Sitting Down (Single Establishment)

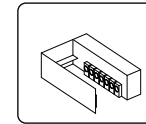

**LAUNDRY**

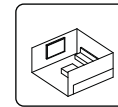

**ENTERTAINMENT BOX-**  
Karaoke, Movie Room rental

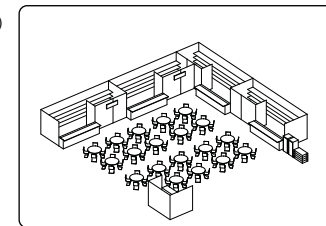

**COLLECTIVE EATING-**  
Multiple establishments

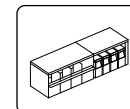

**BANKING**



**KIOSK-**  
Misc. goods

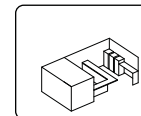

**POSTAL SERVICE**

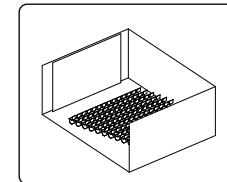

**COLLECTIVE ENTERTAINMENT-**  
Theater, Movies



**VENDING**

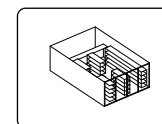

**RETAIL BOX**

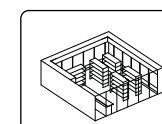

**GROCERY MART**

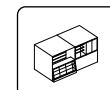

**FOOD TO GO**



**INFO**

## URBAN ACCUPUNCTURE-

The grafted infrastructural systems would appear on the blocks of new subway stations. This will create an urban acupuncture of hybrid nodes in the city. The structures adapt to the different sites adjusting to the surrounding typologies. The repetition of the system throughout the city becomes a new typology for a subway station recognizable by the architecture and not the subway signs. The stations would range in scale from a pavilion scale to a high-rise.

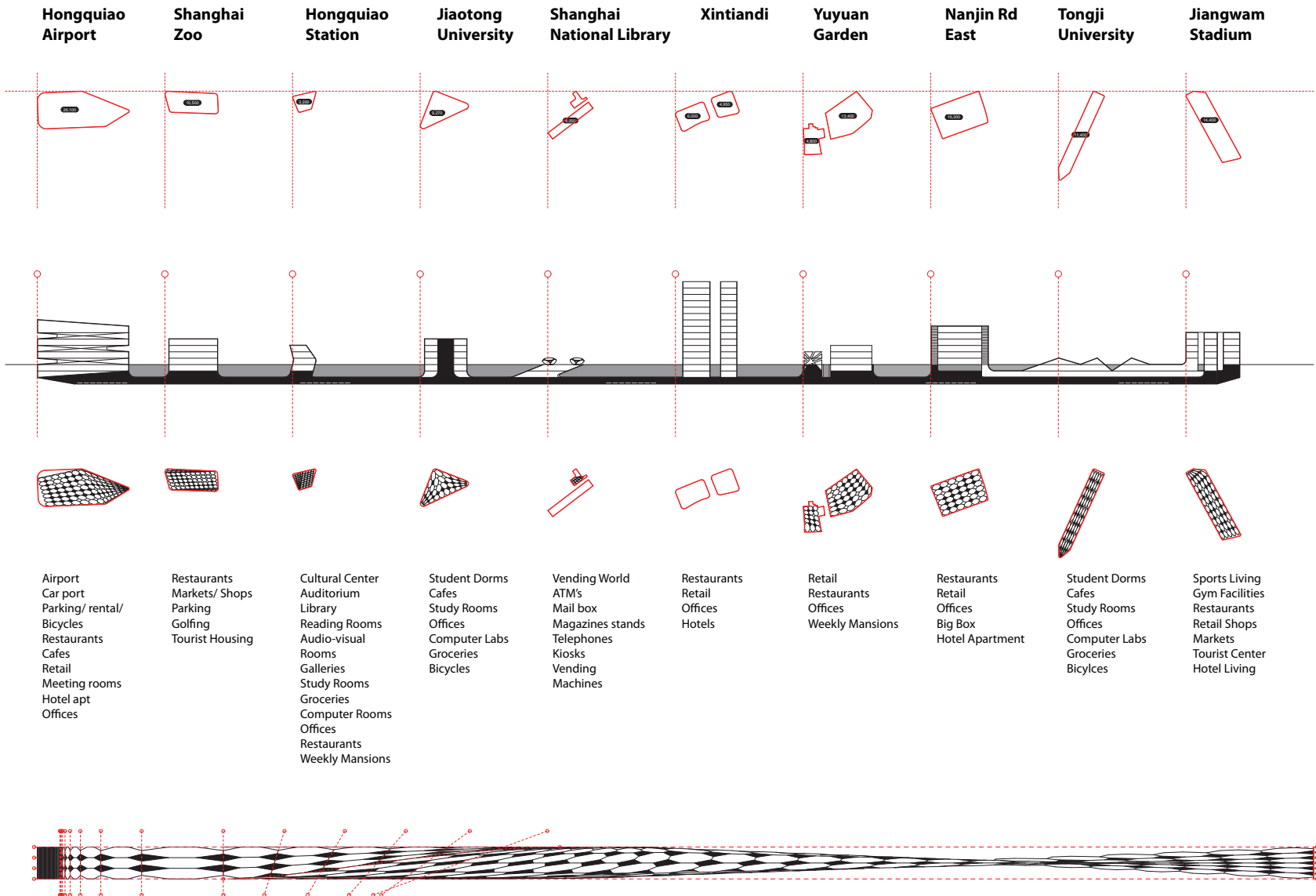

**PAVILION**- Subway Exits  
-Shanghai National Library  
-Xintiandi  
-Yuyuan Garden  
-Nanjin Road

**MEGA BLOCK**- Single city block structure  
-Hongquiao Airport Station

**DEEP BLOCK**- Horizontal Low Rise High Density  
-Hongquiao Station  
-Jiaotong University

**LINEAR BLOCK**- Elevated  
-Hongquiao Station  
-Tongji Station  
-Jiangwam Station

**VERTICAL BLOCK**- High Rise  
-Shanghai Zoo Station  
-Yuyuan Garden Exterior Site  
-Nanjin Rd East

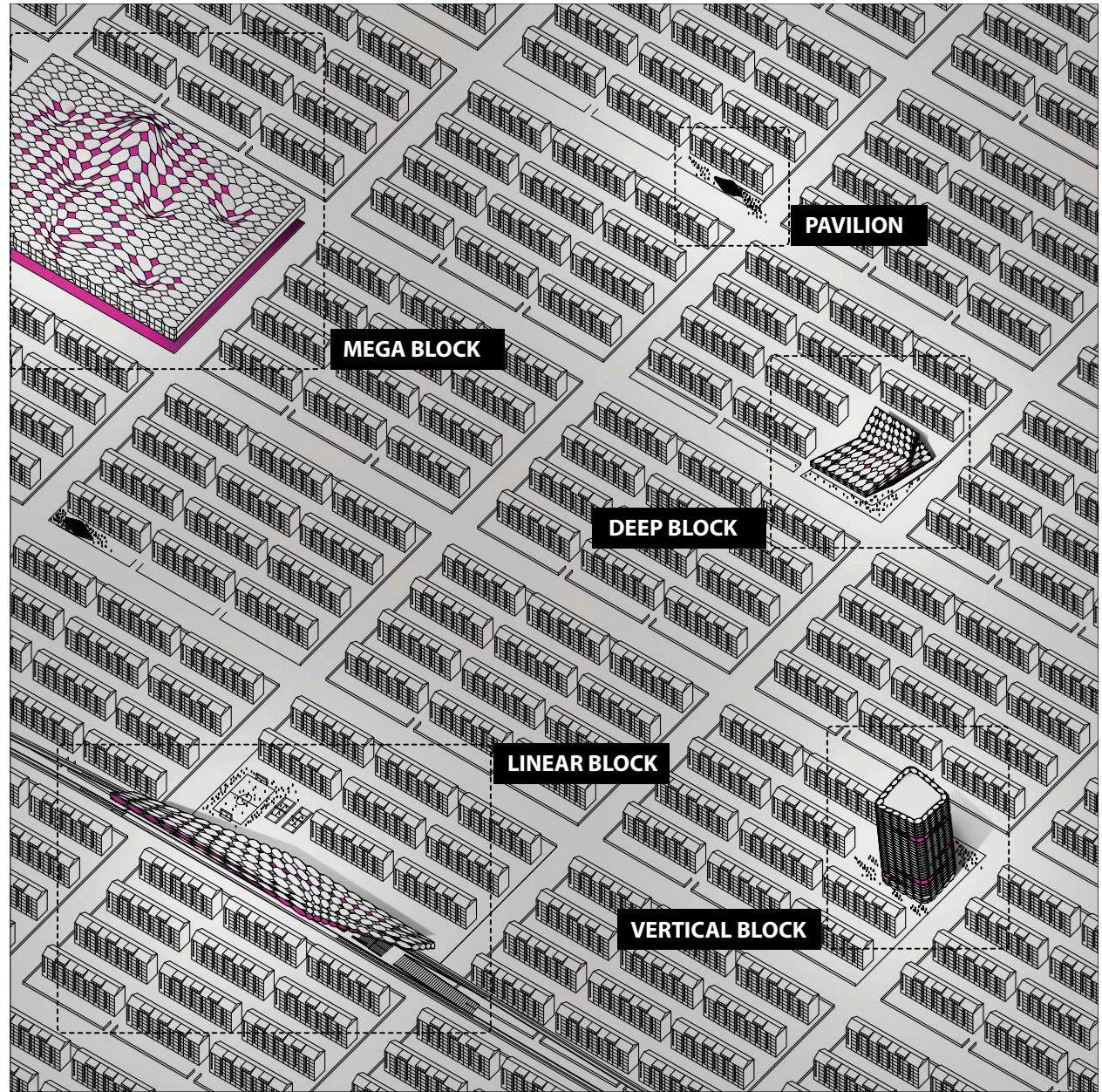

## NANJIN RD- Pavilion

Pavilion Stations follow in the spirit of "Pet Architecture". They try to generate metropolitan programs with minimum sizes. They mostly address the vending world. In this case the structure houses an elevator, ticket booth, ticket vending machines and escalators to the underground. The structure wraps around these components to generate a shell.

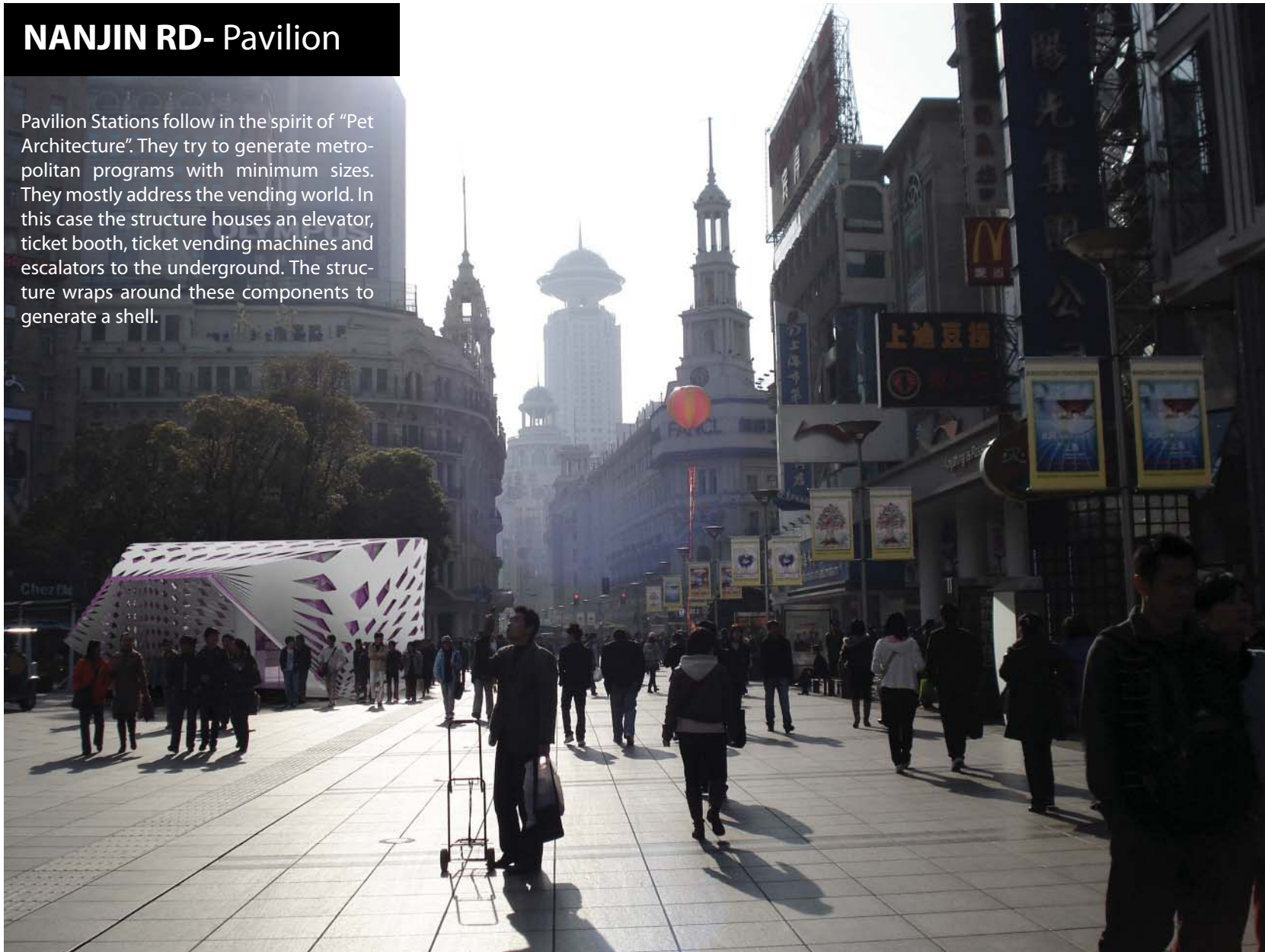

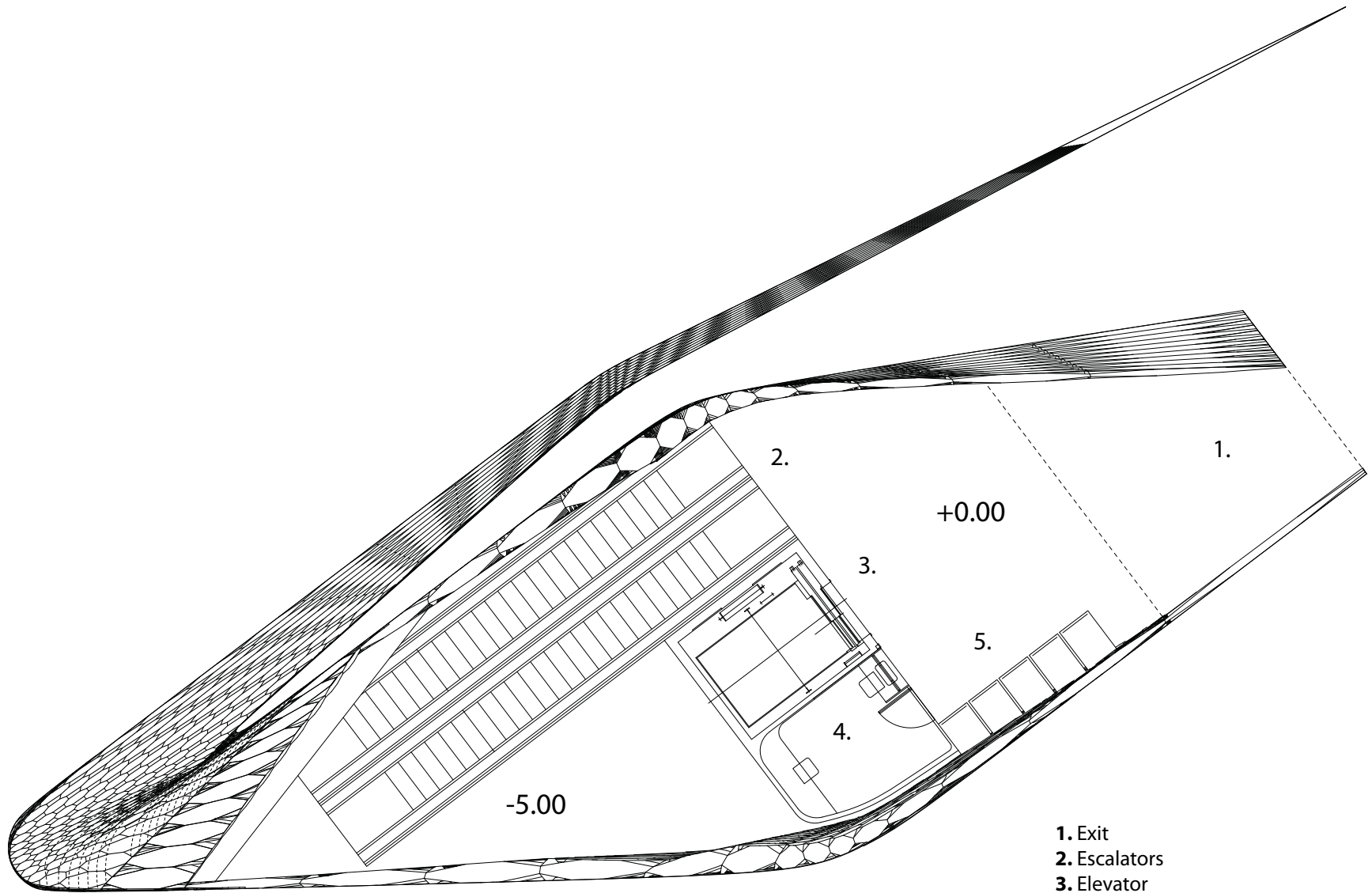

-5.00

+0.00

2.

3.

4.

5.

1.

- 1. Exit
- 2. Escalators
- 3. Elevator
- 4. Operator Booth
- 5. Subway Ticketing Machines

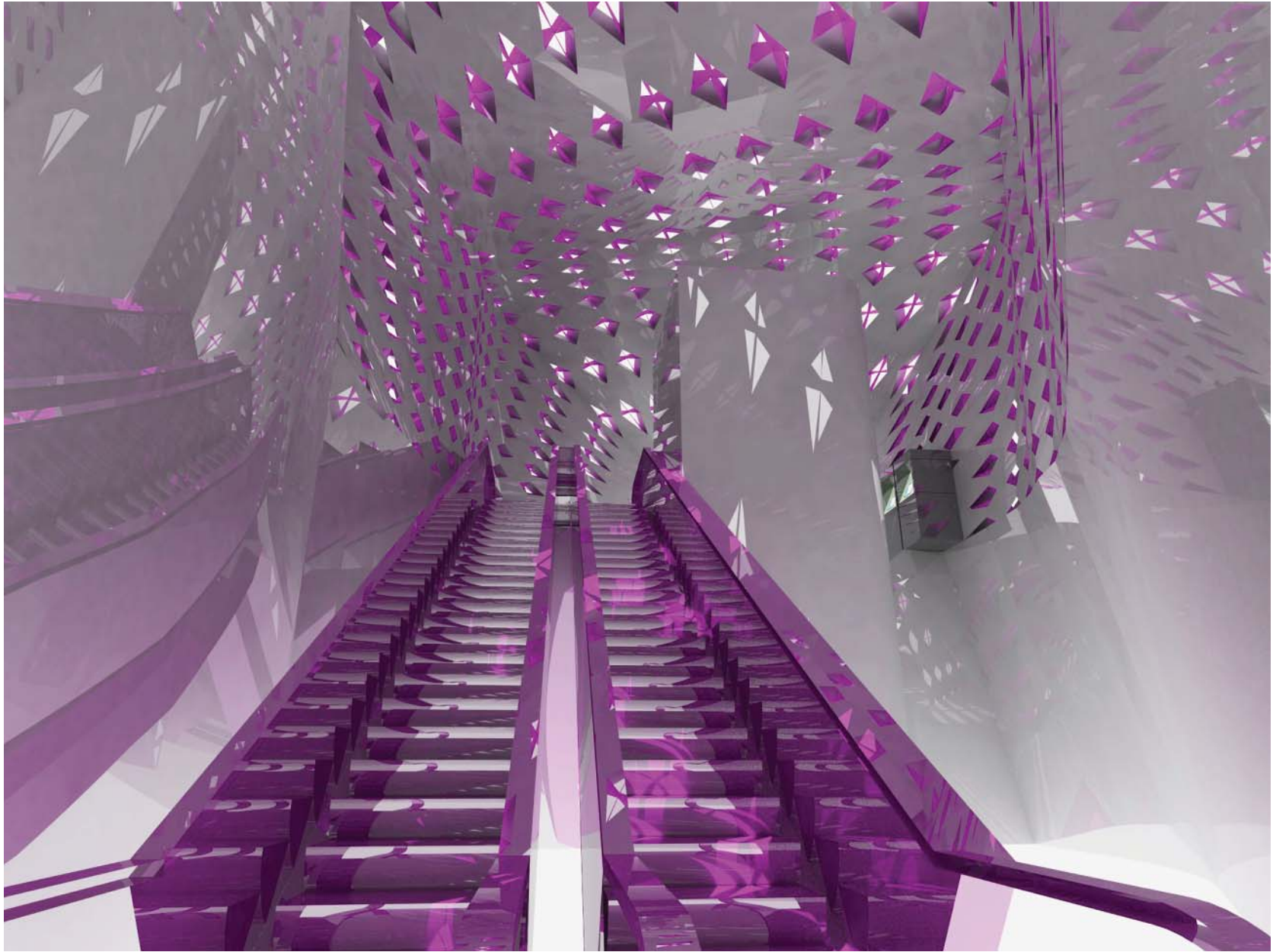

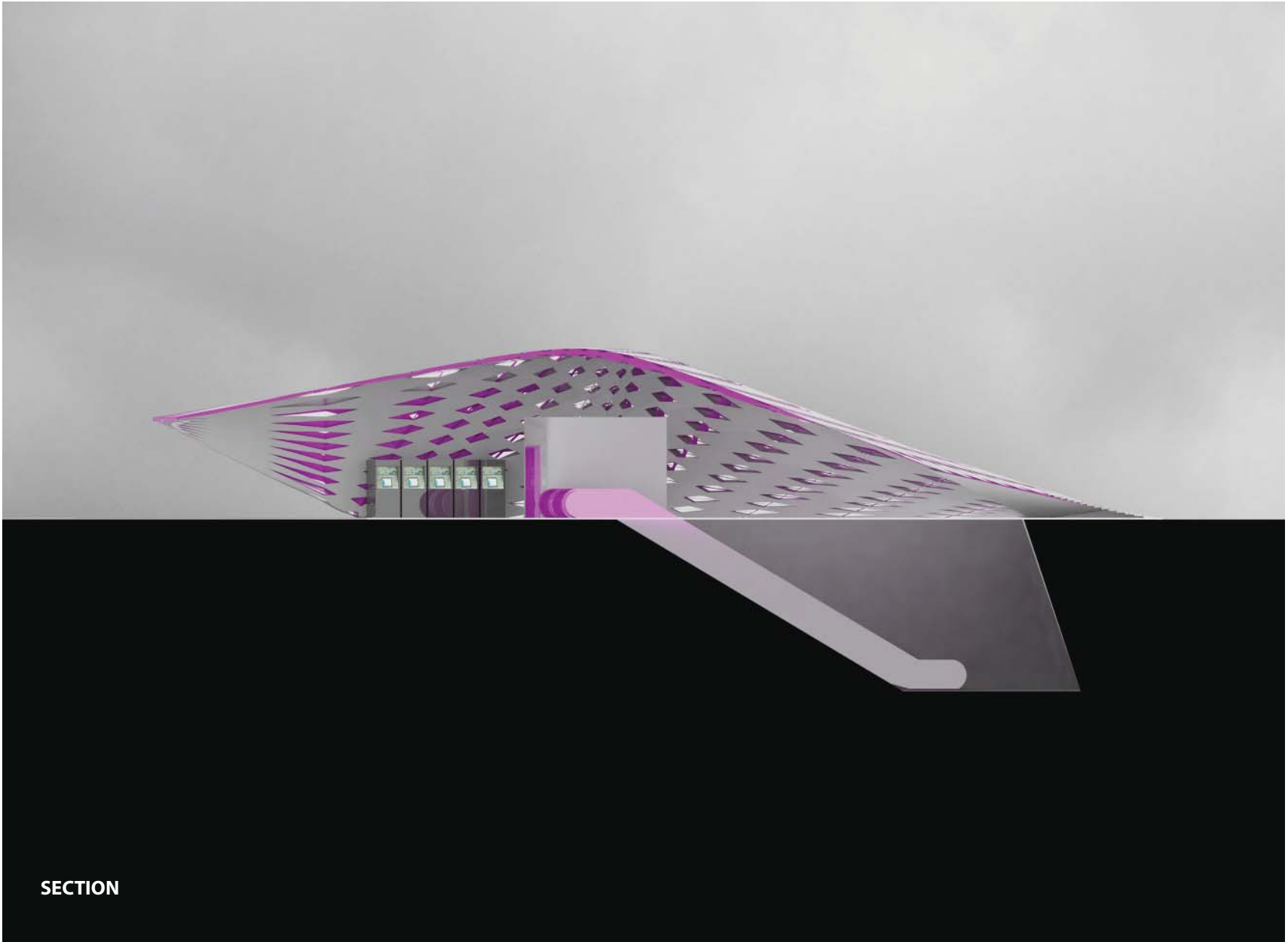

SECTION

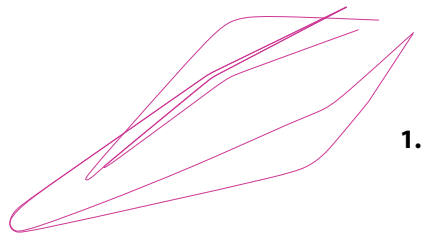

1.

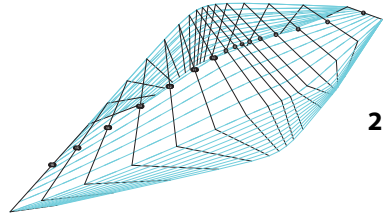

2.

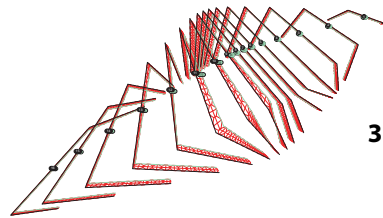

3.

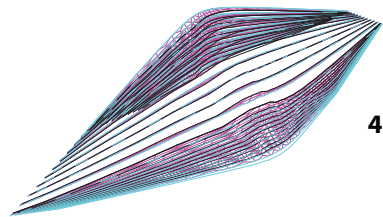

4.

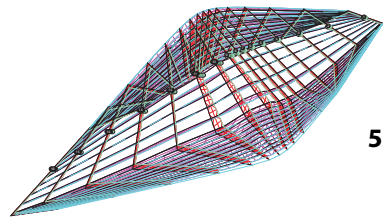

5.

- 1. Curves
- 2. Divisions
- 3. Inner Spine (V Direction)
- 4. Inner Spine (U Direction)
- 5. Inner Paneling
- 6. Outer Paneling

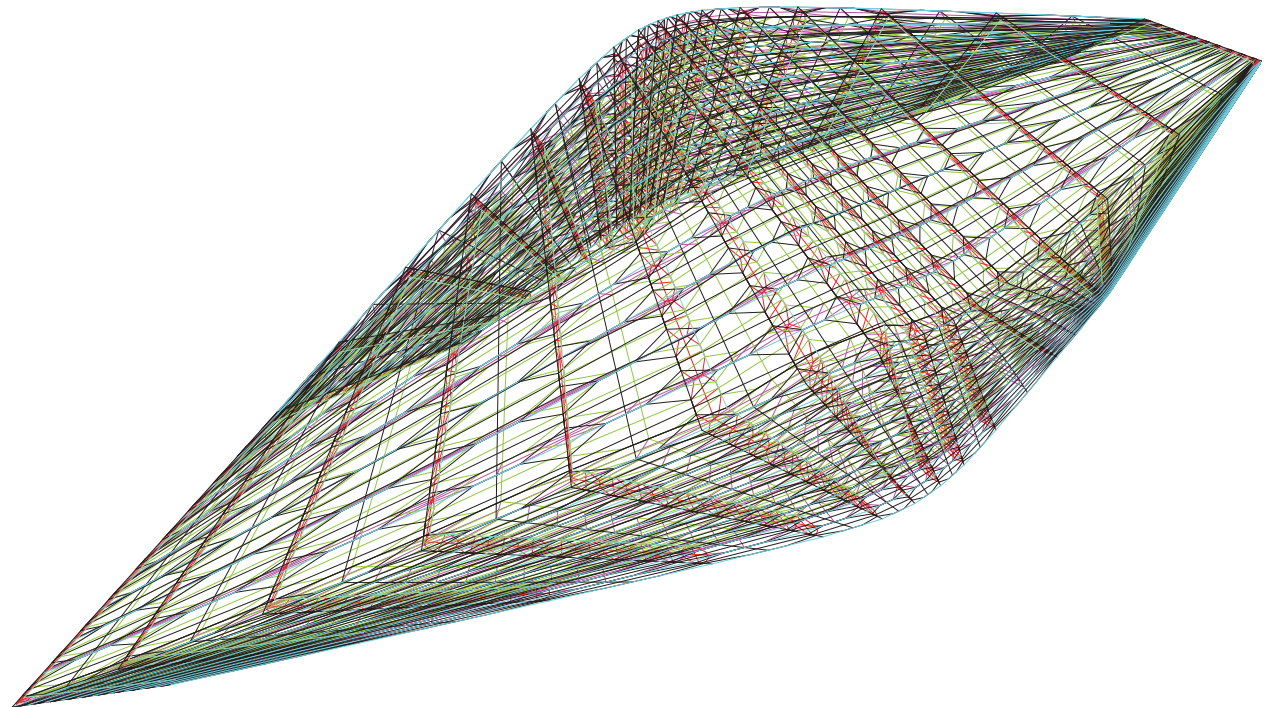

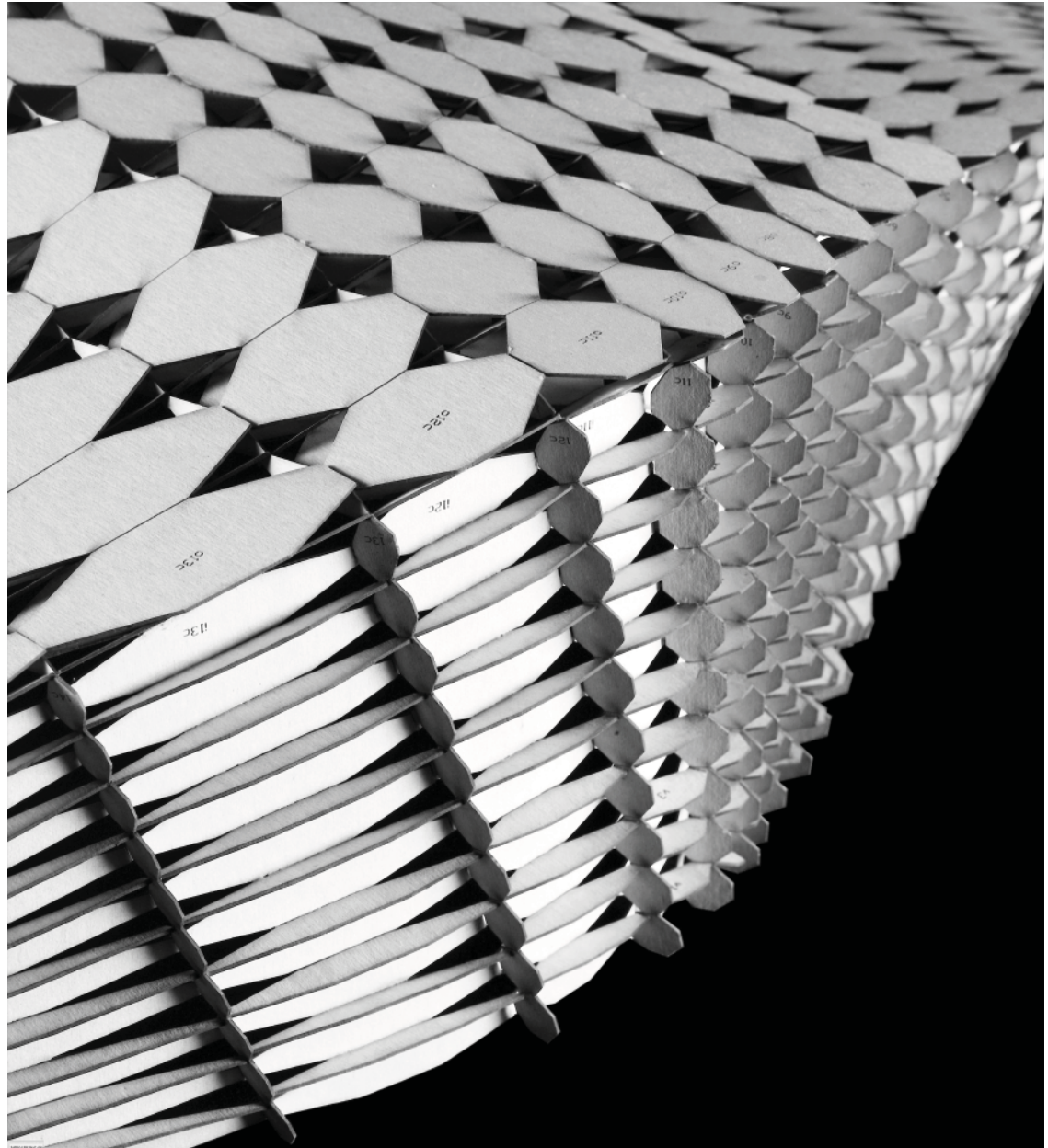

The structural logic is propagated throughout the entire shell. The inner spines adjust to sunangles and the need for opacities for privacy.

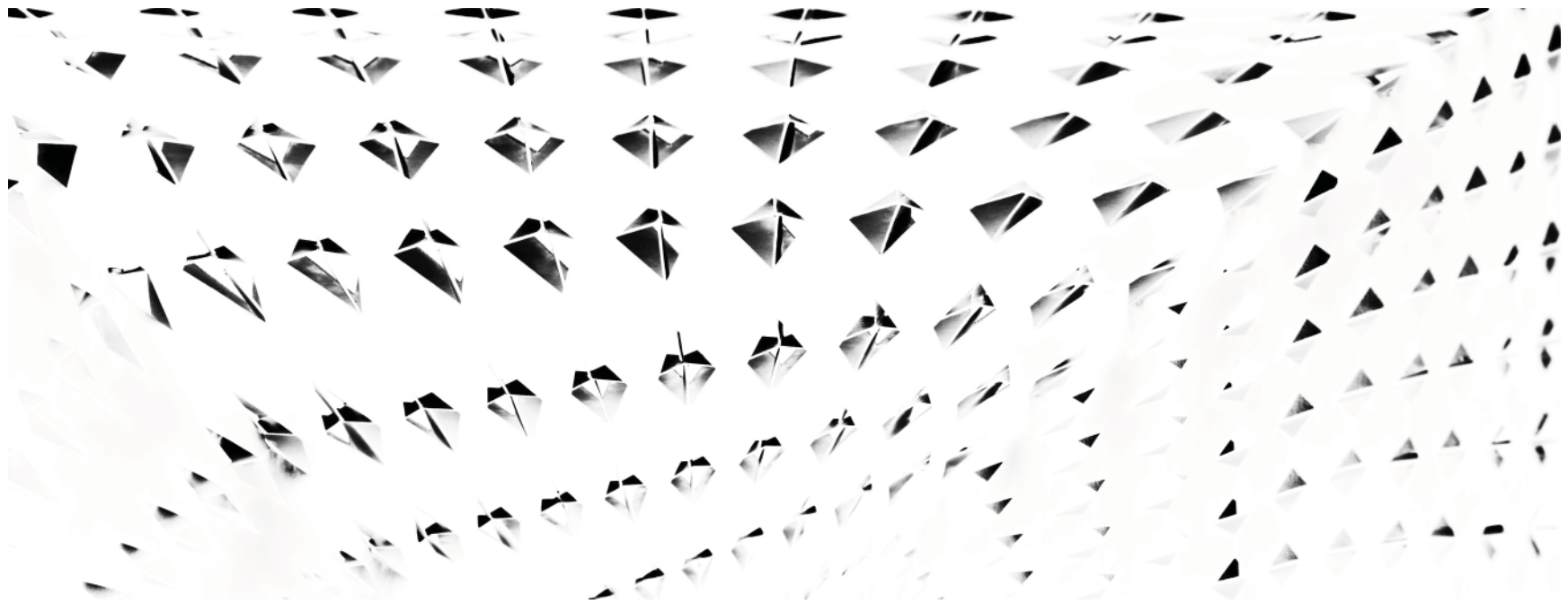

### **PATTERN AND ORNAMENT**

The patterns that are produced in the facade are directly linked to the function of the structural logic. Patterning is a by-product not the generator. Pattern, structure, facade, and ornament are parametrically linked by the same logic. This produces an autonomy of the elements.

**TOP HORIZONTAL INNER SPINES**

Parametrically linked to the sun-path to allow for natural light.

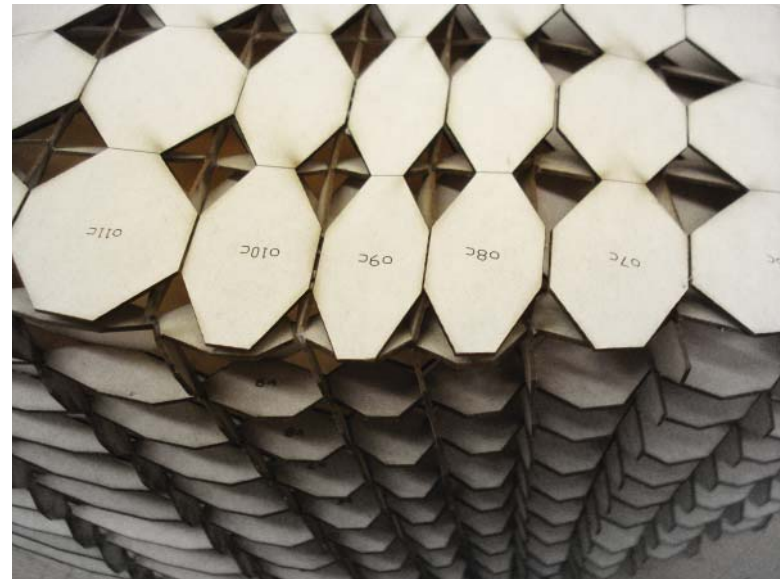

**VERTICAL INNER SPINES**

The angle and distance between them allows for privacy and opacities.



# HONGQUIAO STATION- Intersection Between Linear Block and Deep Block

Hongquiao Station lies at the border of the inner ring where line 3,4, and future line 10 will meet. Line 3 and 4 are on an elevated track and line 10 will be underground. The surrounding neighborhood has a population of students, and staff from Jiaotong University and Donghua University. The Shanghai National Library is in close proximity and the Shanghai City Museum of Sculpture is in the next block. The station should reflect the cultural value that triangulates amongst the institutions.

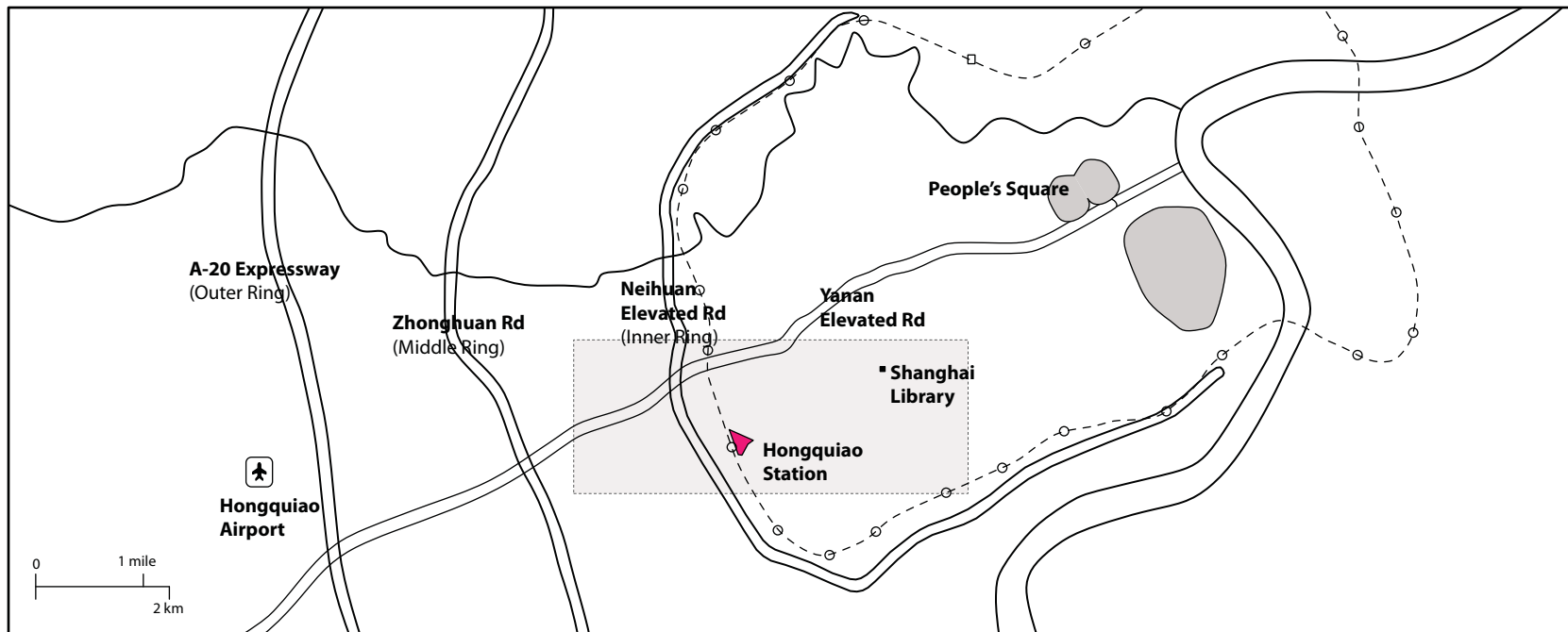

City Diagram

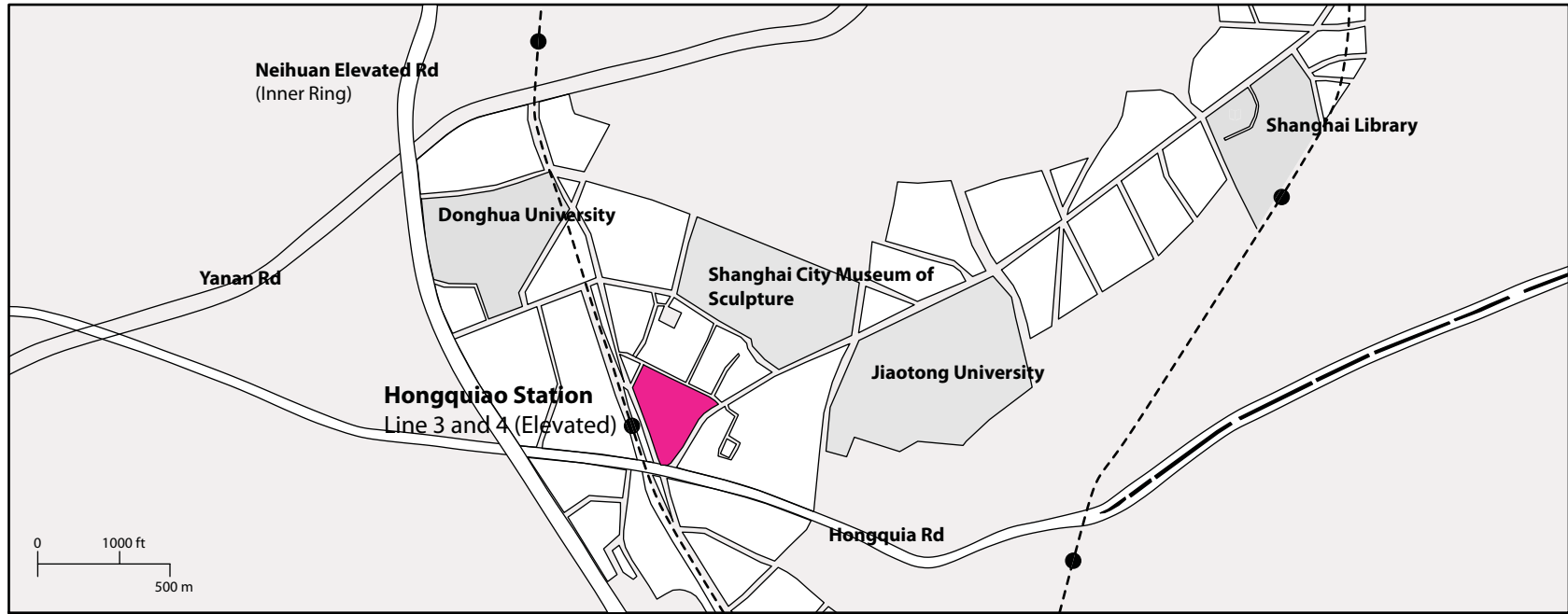

Neighborhood Diagram



Noli Plan-existing condition



Site Connections

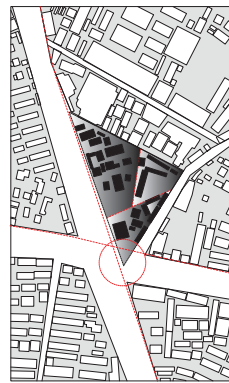

Site Edges

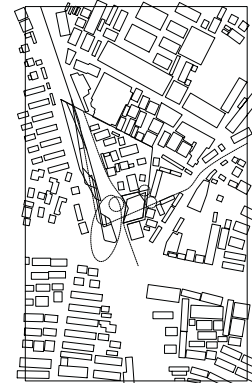

Flow Through Site



Noli Plan- new conditions

## DEEP-BLOCK

Both stations present different characters on the outside but are connected through the underground.

## LINEAR-BLOCK

**Condition**

**Platform Extrusion**

**Single Building:**

**Vertical Connection**

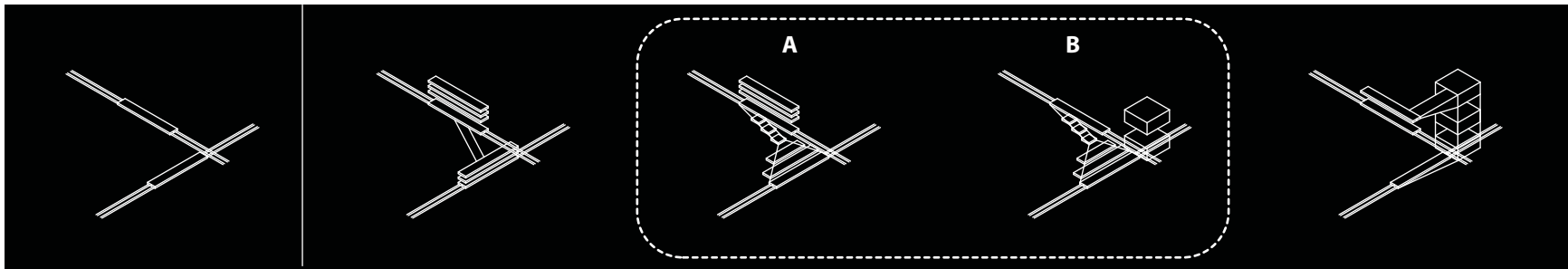

Elevated Light Rail (Line3, and 4) and New Underground Subway Line 10 are to be linked in a single station.

The area above and below the platforms is reclaimed for additional program.

Both Stations are linked by a single horizontal building.

Additional program is added on an adjacent site while the stations are linked underground.

Both Stations are linked above ground by adjacent site.

# HONGQIAO STATION- Deep-Block

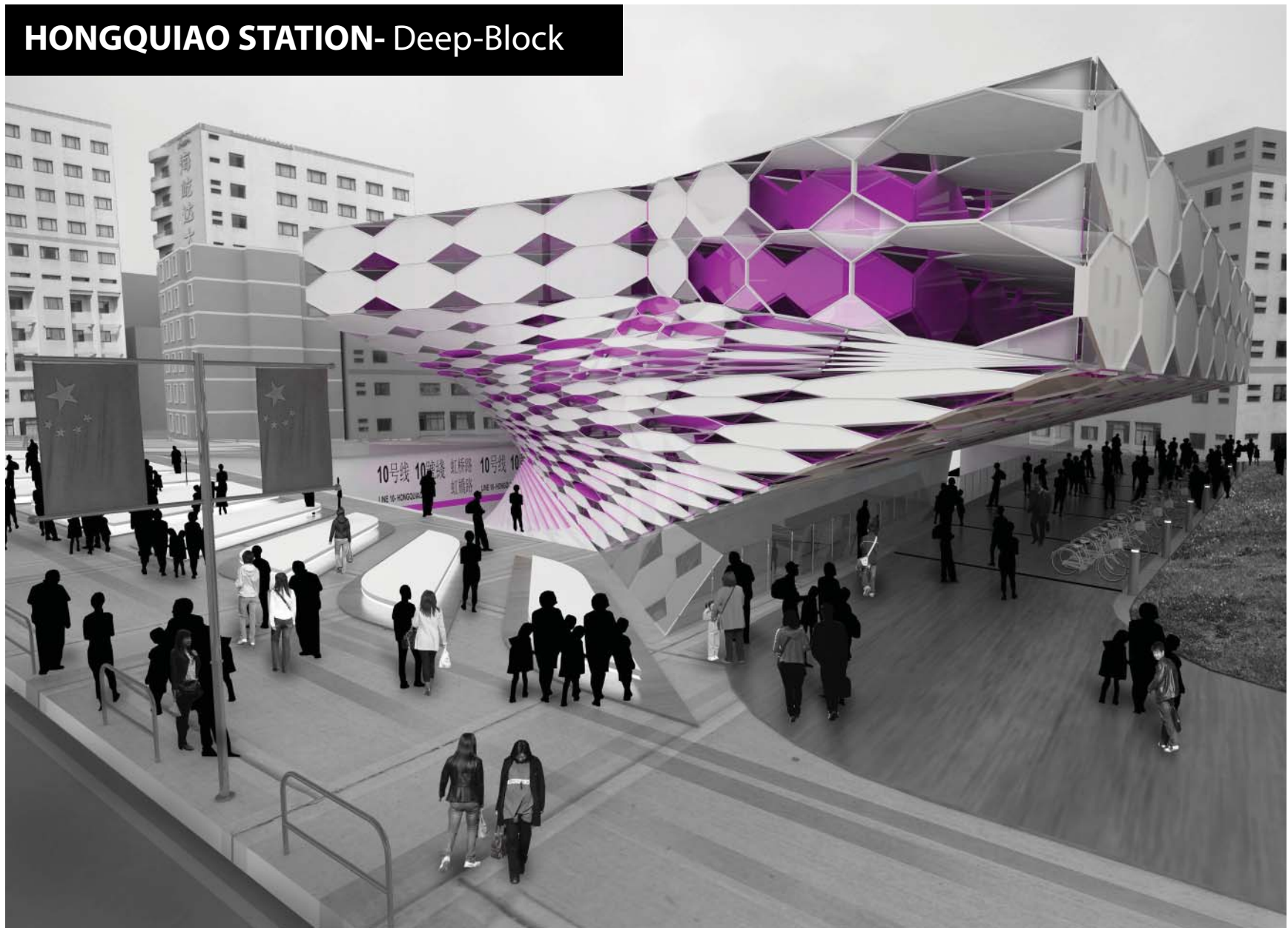

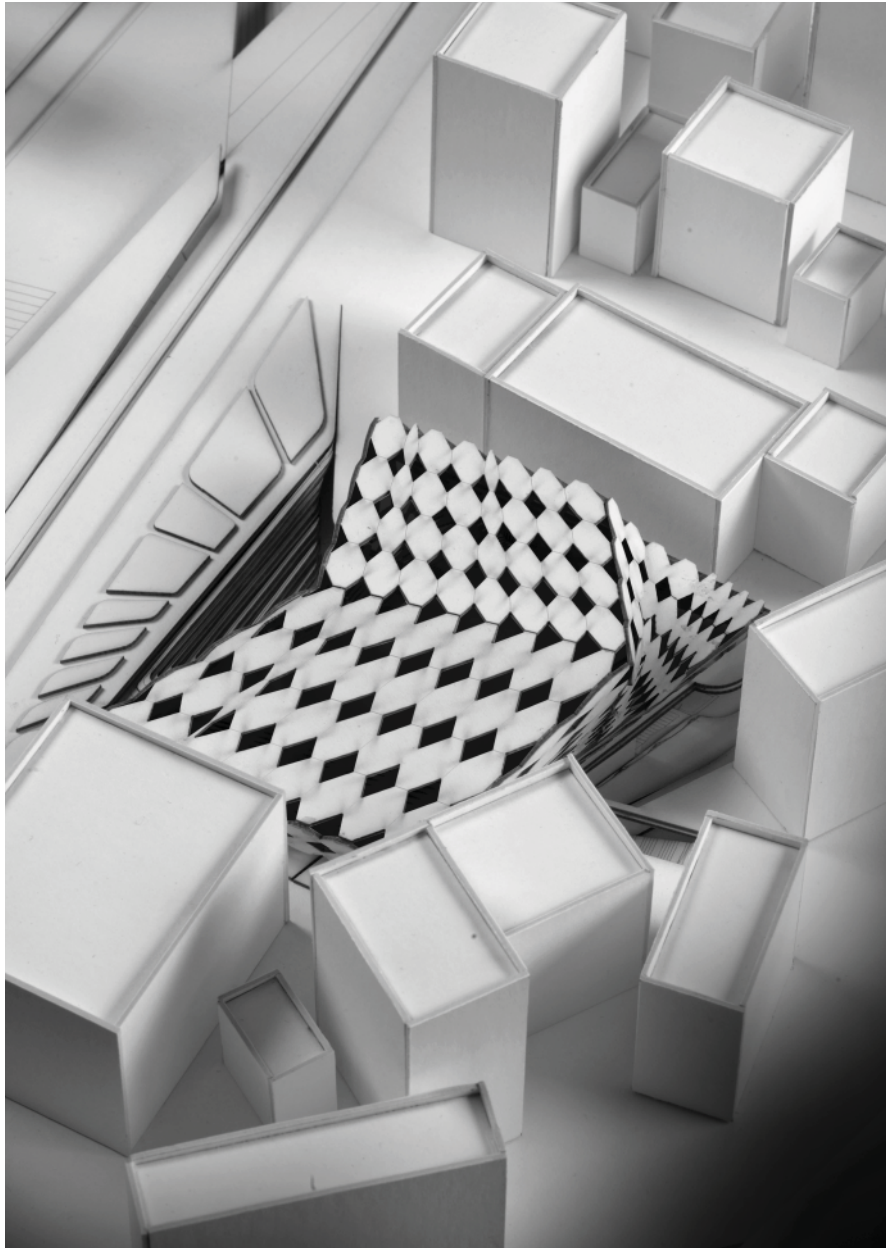

As cities and urban center continue to grow, infrastructure becomes a greater demand. Hongquiao Station lies between to major universities, in the proximity to Shanghai National Library, to the Shanghai City Museum of Sculpture, and several Embassies. It also link line 3,4 on the elevated train. The new station allows for temporary housing units that merge with office spaces, a public theater with the subway, and an underground retail street.



Base Aerial Photograph from Google Earth

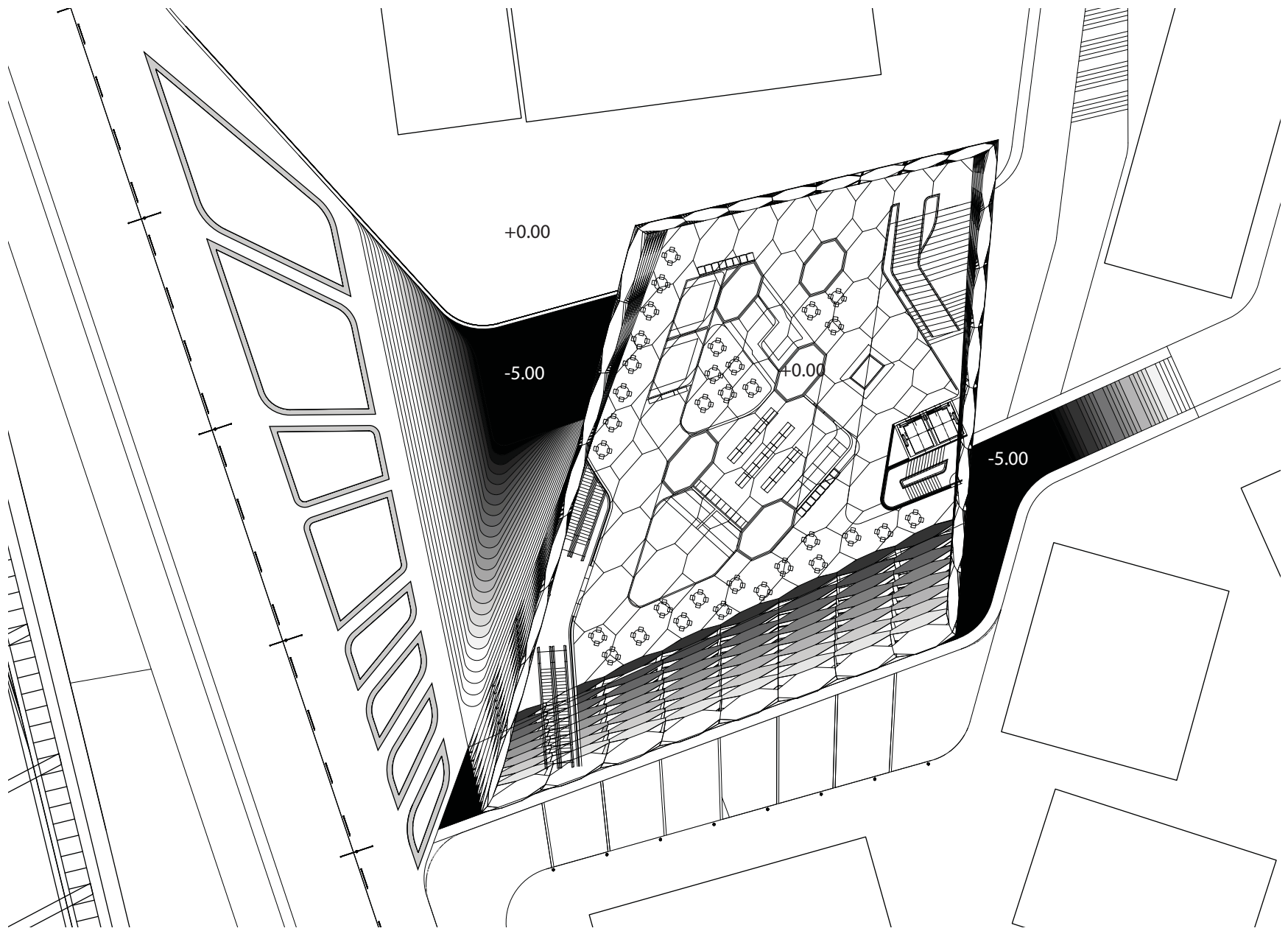

## UNDERGROUND-

The vertical circulation components have been merged into the structure to guide the space. On the lower level, the escalators generate a lobby space and circulation for the train passengers and a public theater.

**LEVEL -5.00**  
Ticketing  
Vending Machines  
Retail Underground Street  
Information  
Subway Offices  
Entrances  
Public Toilets  
Food

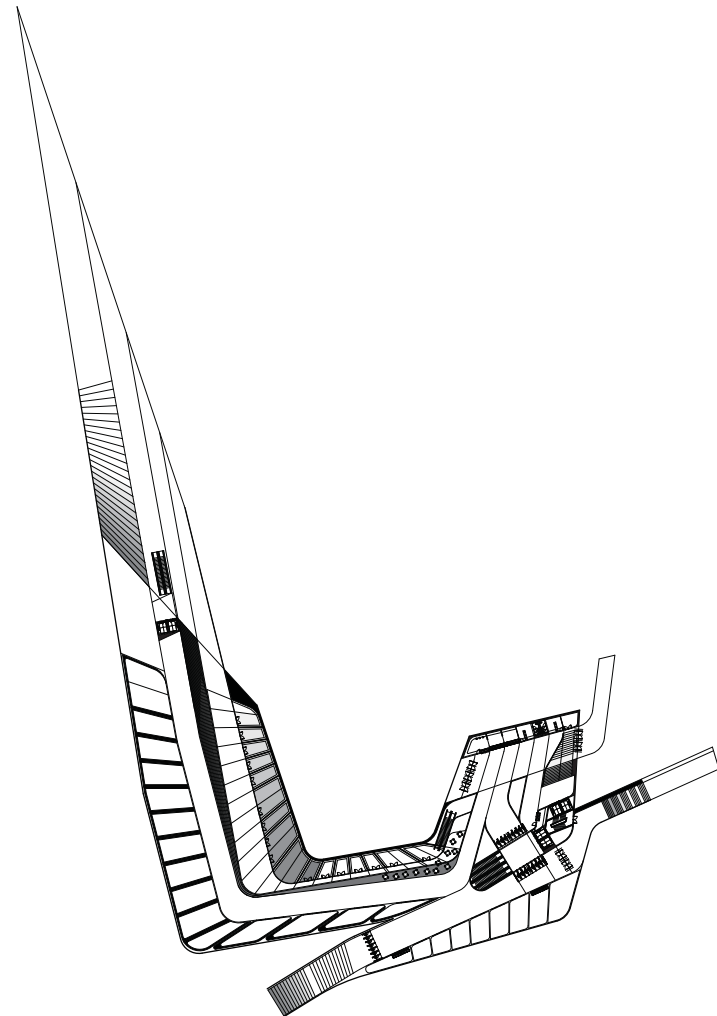

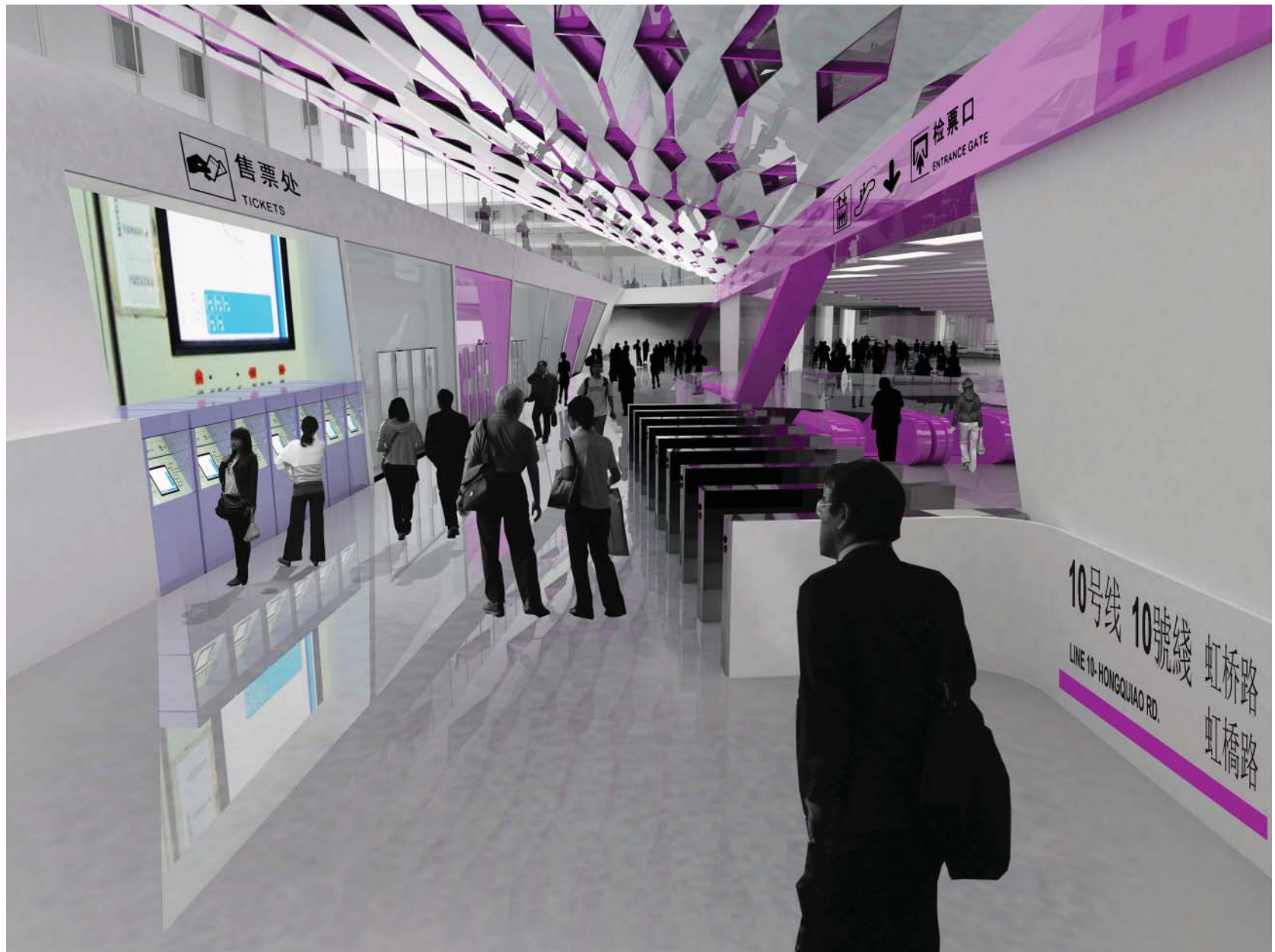

**LEVEL -10.00**  
Vending Machines  
Retail  
Media Tables  
Public Toilets  
Theater Support Spaces  
Food

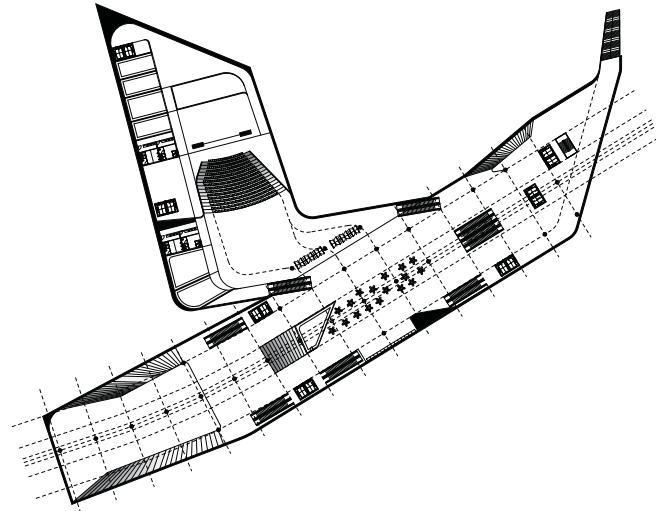

**LEVEL -15.00**  
Trains  
Vending Machines  
Public Theater  
Lobby  
Public Toilets  
Theater Support Spaces  
Food

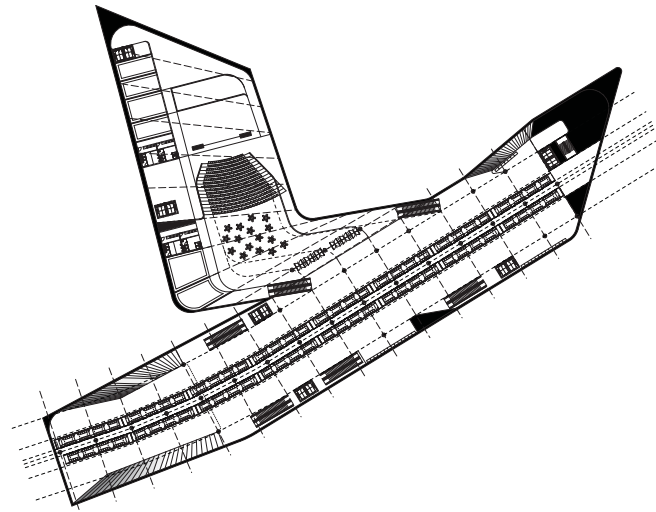

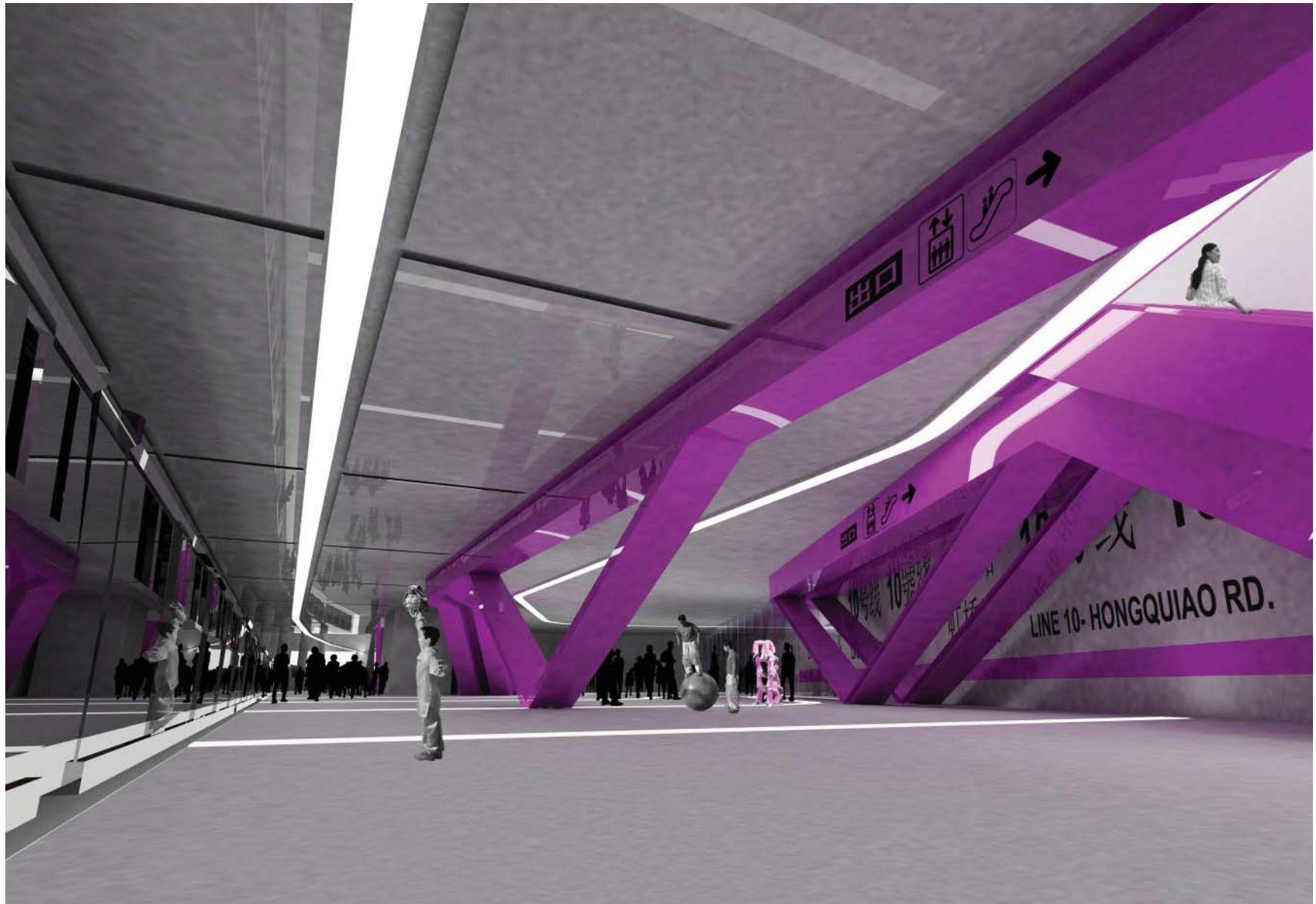

## ABOVE GROUND-



The repetition of the system throughout the city becomes the recognizable typology for the stations. The entrance to the station is directed by the shifting architecture.

The upper section of the station comprises housing units, office spaces, retail spaces, and food retailers. The facade shifts with the sun angles allowing for direct sunlight and allows for the electrical and mechanical systems to filter through.

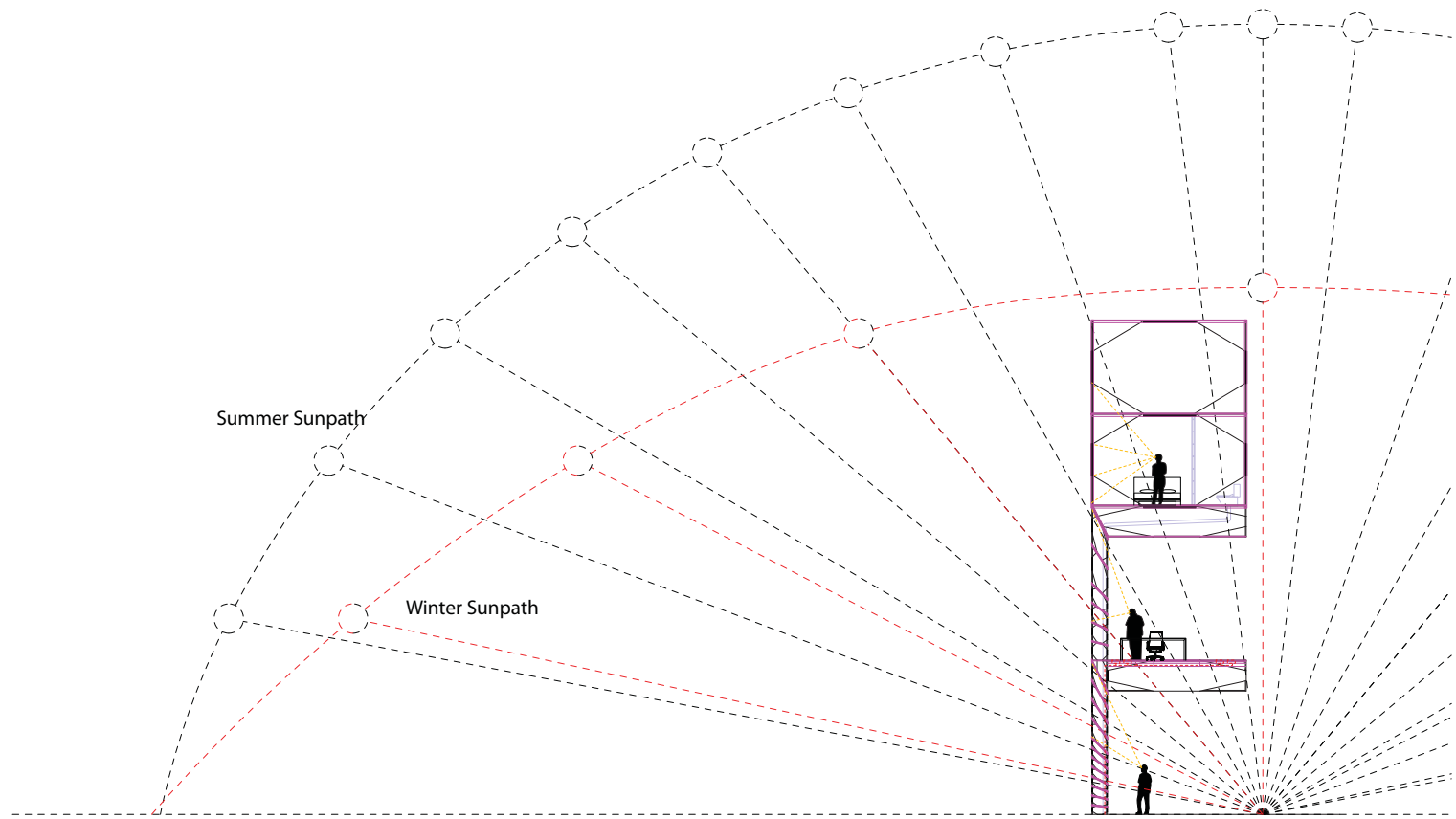

West Wall Section Diagram



**LEVEL +5.00**

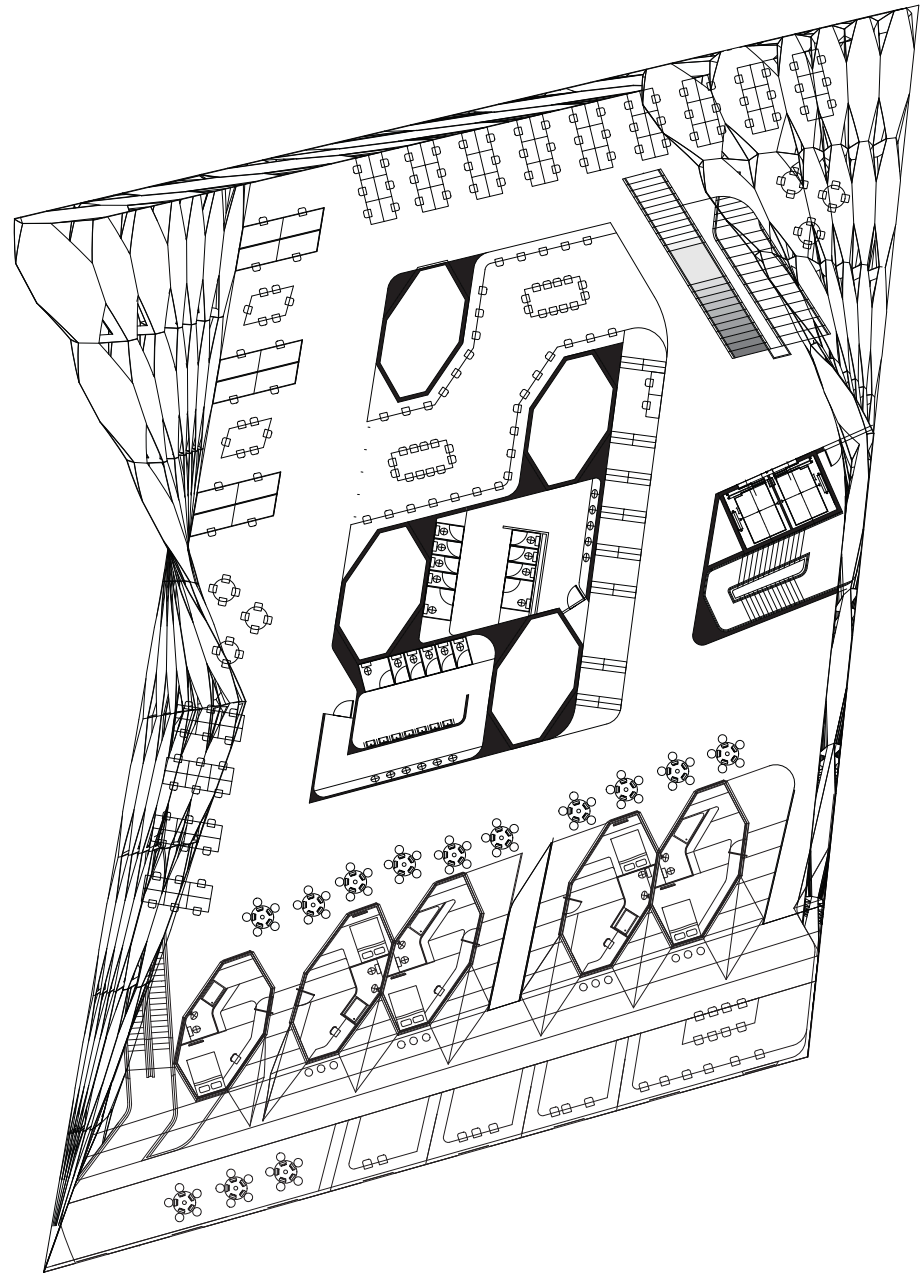

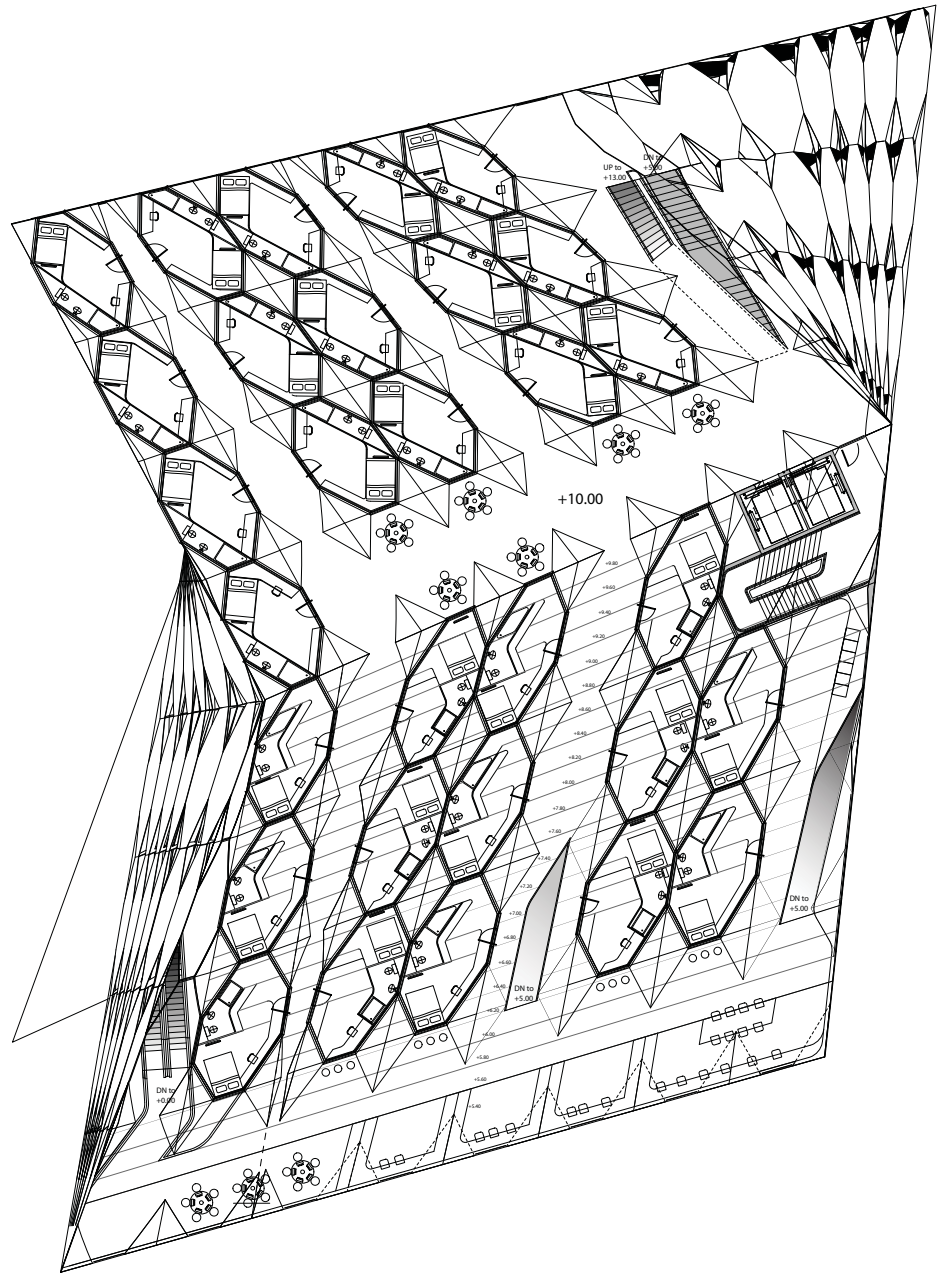

**LEVEL +10.00**

**LEVEL +13.00**

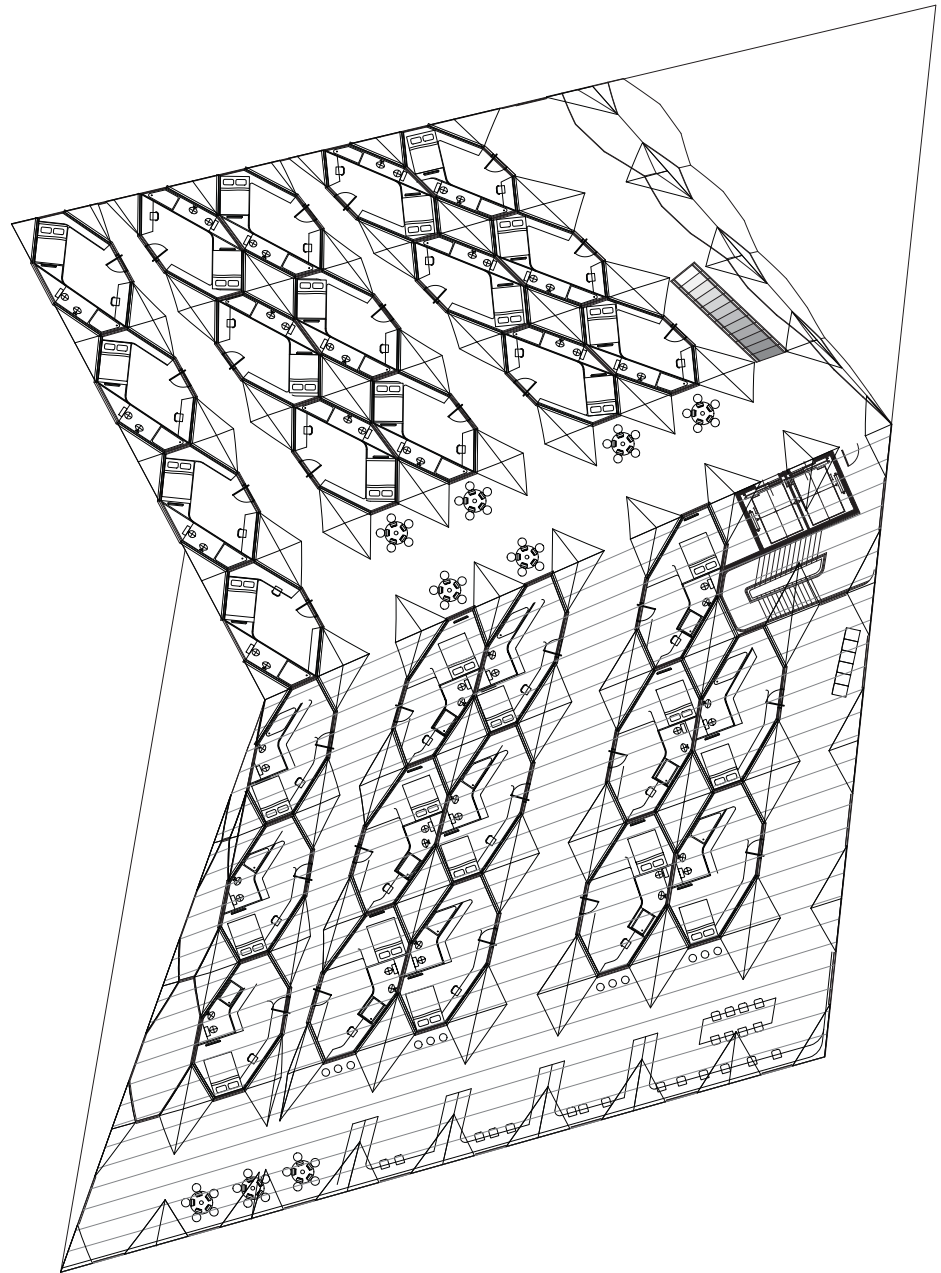

# SECTION-

## North-South Cross Section

The stacking of layers of different programmatic use derives from the concept of verticalism in a skyscraper. This section tries to break the layering by combining circulation elements from the subway with the structural and infrastructural elements. This follows the circulation and breaks the different layers so that social mixing can be stimulated.

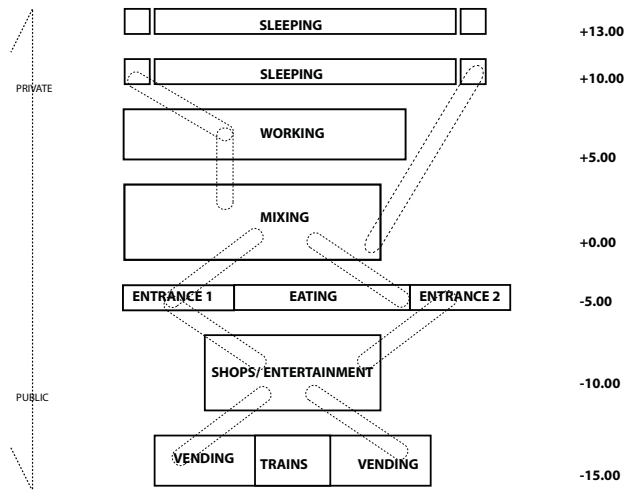

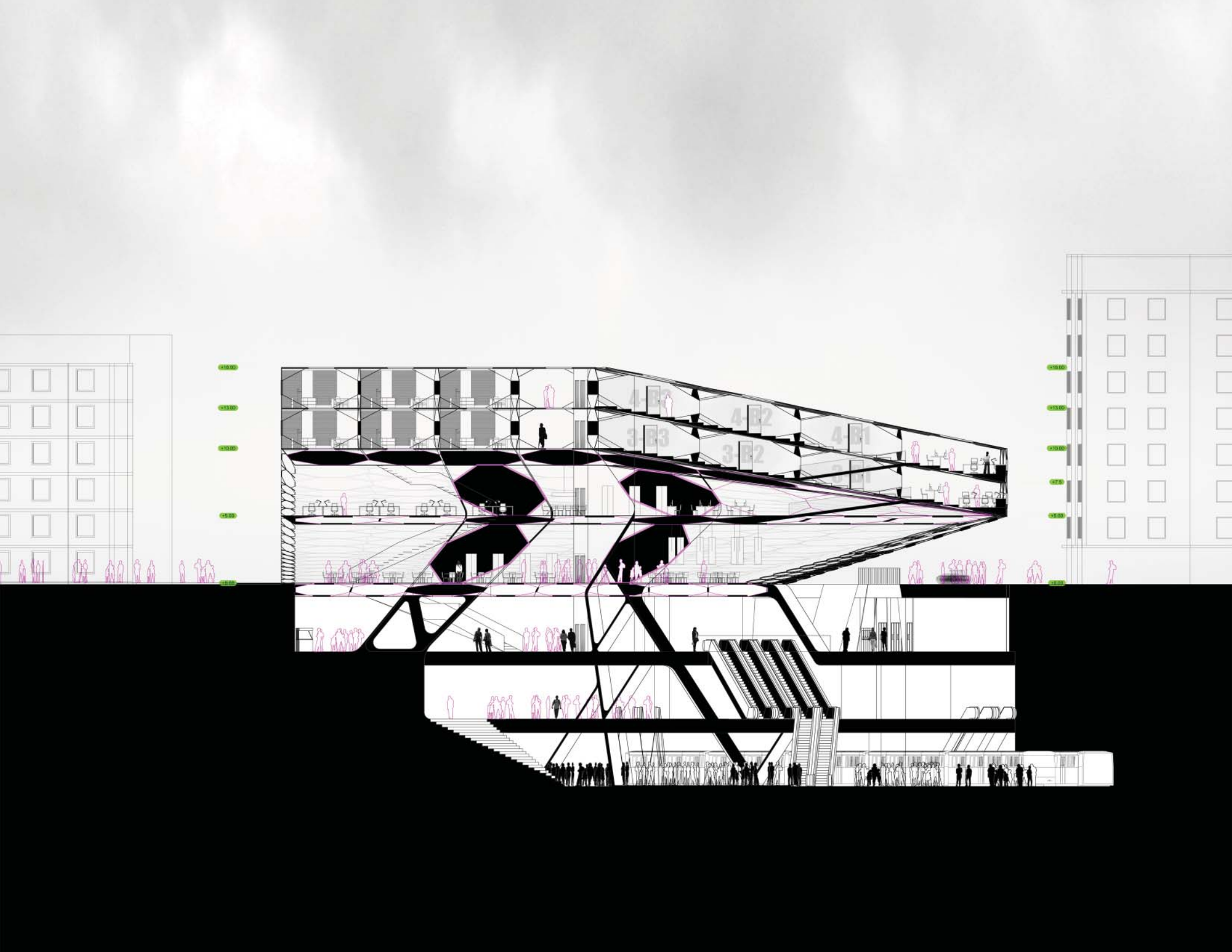

## LIVING POD

As the family unit breaks down and migration increases, there is a need for a reduction of living space downtown in order to achieve a higher sustainable density. The house unit, which was once from 80 to 100 sqm, can be broken down to its components and displaced into just essential sleeping quarters. The additional housing program can be displaced throughout the building as shared spaces and creates a social mixing. Housing should become a byproduct of the infrastructural system that generates neutral settings.

## FLAT

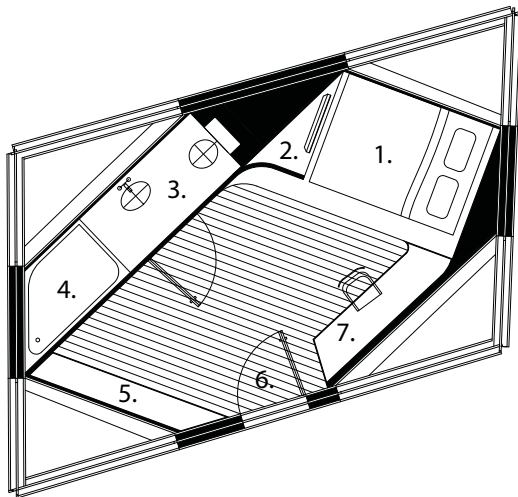

1. Bed
2. TV
3. WC
4. Tub
5. Storage
6. Entrance
7. Desk



## ASCENDING

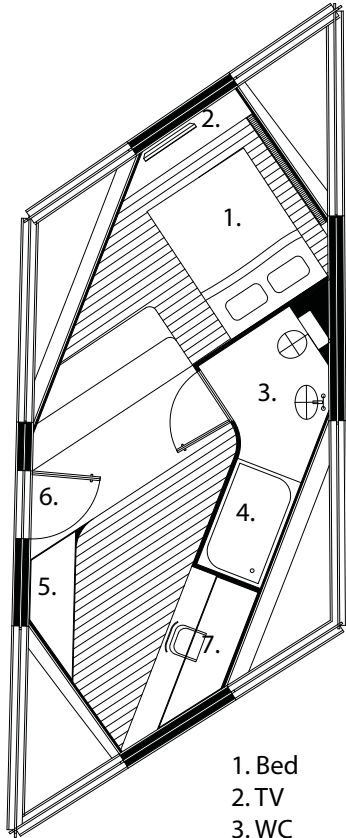

1. Bed
2. TV
3. WC
4. Tub
5. Storage
6. Entrance
7. Desk

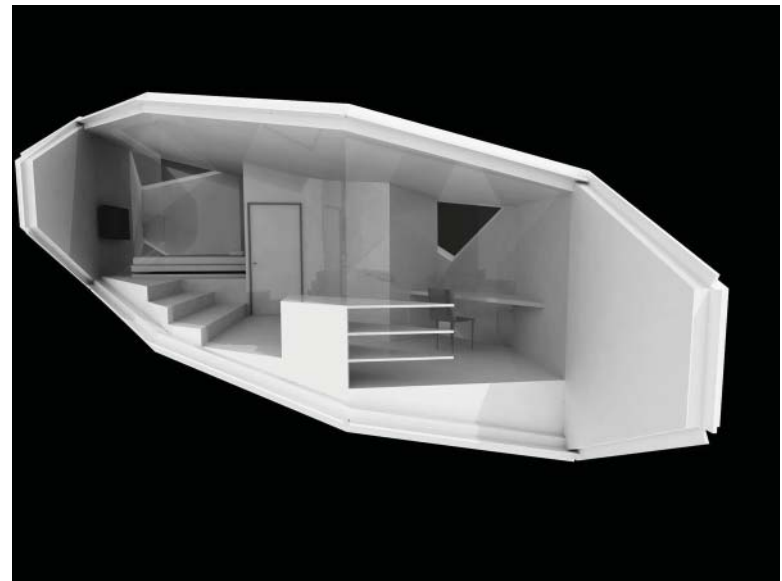

## DESCENDING

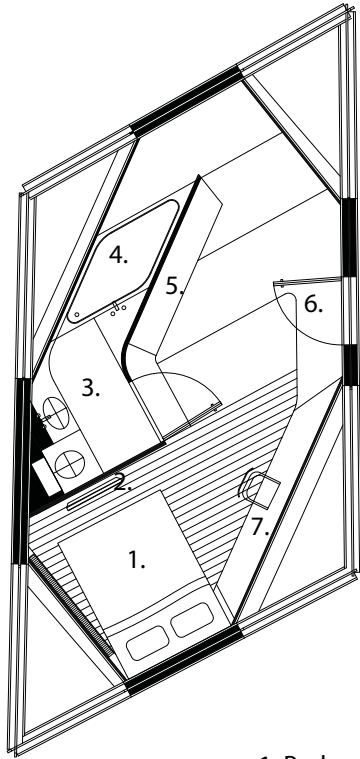

1. Bed
2. TV
3. WC
4. Tub
5. Storage
6. Entrance
7. Desk

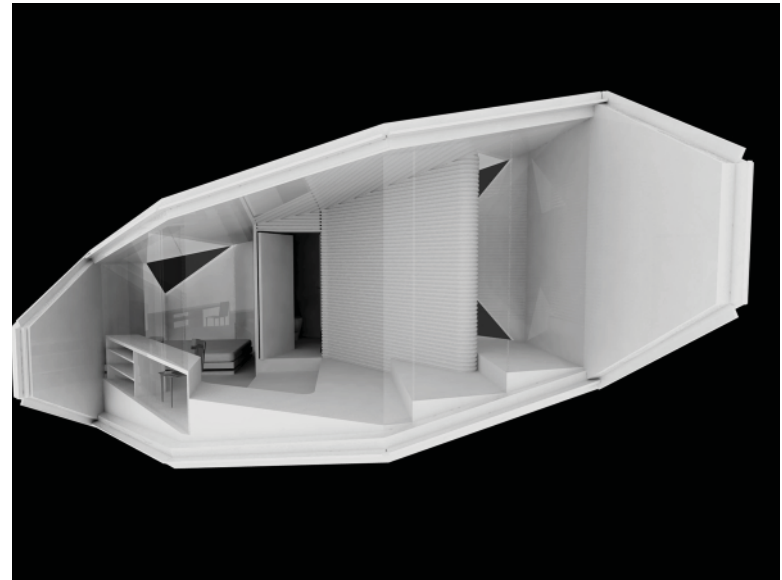

# FABRICATION OF PODS- Fiberglass Casting

The fiberglass casting technology in the boat industry can be translated into architectural construction. A macro mold can be altered to produce multiple panels for the pods with minimum waste. The resulting piece is structure, weatherproofing, and finish material.

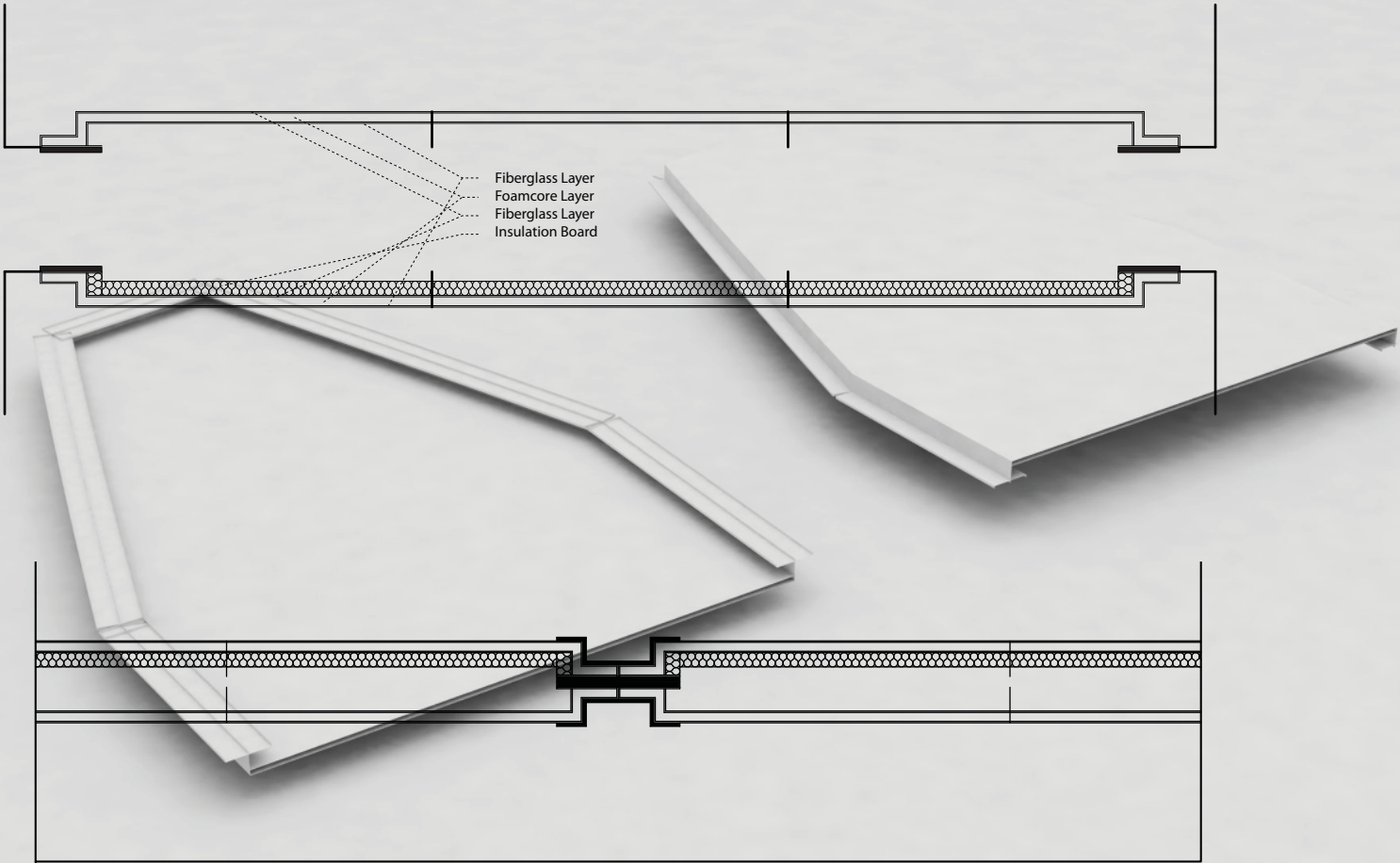

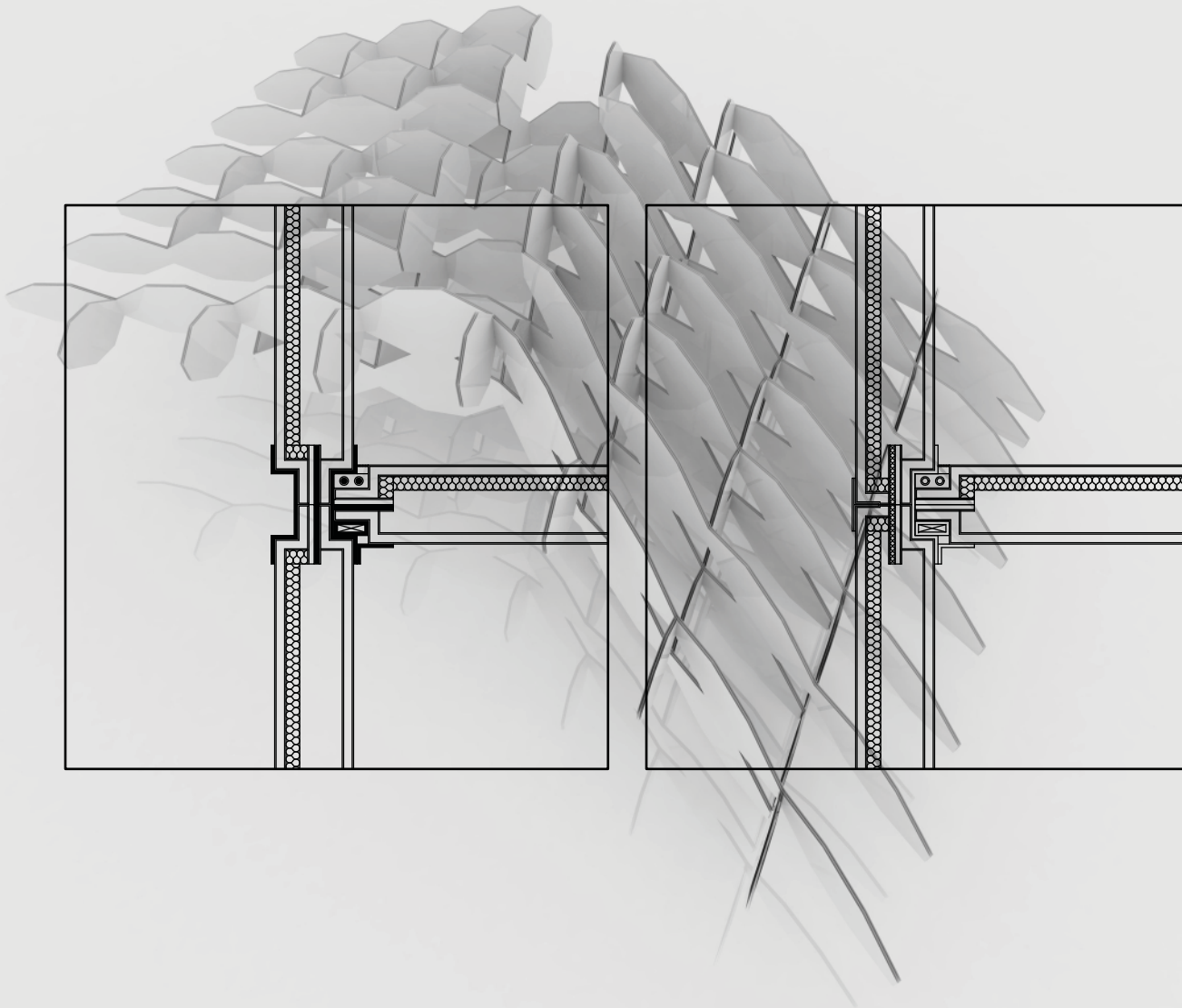

## ACKNOWLEDGMENT

I would like to thank my committee, Julian Beinart, Stanford Anderson, Mark Goulthorpe, and Yung Ho Chang, for their constant support and guidance throughout the development of my thesis.

To all my professors at MIT, who have opened a new learning path in my career.

To my friends at MIT for making the learning process more enjoyable. The Dudio, John, Joe, and Duncan, whom I have learned from by constantly discussing with each other and generating a healthy competitive learning environment.

To Danielle for staying by my side throughout my studies, and always believing in me.

I would like to thank my family, my parents above all, for their constant support and pushing me to always seek for the best.

Thank you all.

## Bibliography

Abalos, I. (2008). Verticalism. A+T 31 Hybrids 1.

Burdett, R., & Sudjic, D. (2008). The Endless City. London: Phaidon.

Devas, N., & Rakodi, C. (1985). Managing Fast Growing Cities. New York: Longman Scientific & Technical.

Fenton, J. (1985). Pamphlet Architecture No 11- Hybrid Buildings. New York: Princeton Architectural Press.

Gullart, V. (2004). Sociopolis, Project for a City of the Future. Barcelona: Actar and Architekturzentrums Wein.

Kajima, M., & Kuruda, J. (2001). Made in Tokyo. Tokyo: Kajima Institute Publishing Co.

Koolhaas, R. (2000). Life in the Metropolis or The Culture of Congestion. In M. K. Hays, Architecture Theory since 1968 (pp. 320-331). Cambridge: MIT Press.

MUSIATOWICZ, M. (2008). Hybrid vigour and the art of mixing. A+T 31 Hybrids 1.

Simmel, G. (1971). On Individuality and Social Forms. Chicago: The University of Chicago Press.

THILL, A. K. (2006). Specific neutrality. A manifesto for new collective housing. A+T 20 Density 2.

Tschumi, B. (1996). Architecture and Disjunction. Cambridge: MIT Press.

Data collected for diagrams by page:

5. Burdett, R., & Sudjic, D. (2008). The Endless City. London: Phaidon.

10. <http://en.wikipedia.org/wiki/Shanghai>

11. [http://www.urban-age.net/03\\_conferences/conf\\_shanghai.html](http://www.urban-age.net/03_conferences/conf_shanghai.html)

13. <http://www.stats-sh.gov.cn/2004shtj/tjnj/tjnj2006E.htm#>

15. [http://en.wikipedia.org/wiki/Shanghai\\_Metro](http://en.wikipedia.org/wiki/Shanghai_Metro)

<http://www.unescap.org/esid/psis/population/database/chinadata/shanghai.htm>

## Images

All images were created by the author unless otherwise noted.

Base aerial photograph on page 19 and 52 from Google Earth.